

METRIC

MIL-PRF-32143(AT)
w/Amendment 2
23 June 2005
SUPERSEDING
MIL-PRF-32143(AT)
w/Amendment 1
5 March 2004

PERFORMANCE SPECIFICATION

BATTERIES, STORAGE: AUTOMOTIVE,
VALVE REGULATED LEAD ACID (VRLA)

This specification is approved for use by the U.S. Army Tank-automotive and Armaments Command and is available for use by all Departments and Agencies of the Department of Defense.

1. SCOPE

1.1 Scope. This performance specification covers the general requirements for automotive valve regulated lead acid storage batteries (VRLA), also known as Sealed Lead Acid Batteries (SLAB). The batteries are nominal 12-volt batteries that are generally used for starting, lighting and ignition applications, have non-removable covers, and designed for maintenance-free operation.

2. APPLICABLE DOCUMENTS

2.1 General. The documents listed in this section are specified in sections 3, 4 and 5 of this performance specification. This section does not include documents in other sections of this performance specification or recommended for additional information or as examples. While every effort has been made to ensure the completeness of this list, document users are cautioned that they must meet all specified requirements documents cited in sections 3, 4 and 5 of this performance specification, whether or not they are listed.

Comments, suggestions, or questions on this document should be addressed to Tank-automotive and Armaments Command, 6501 E. 11 Mile Road, Warren, MI 48397-5000 or emailed to standardization@tacom.army.mil. Since contact information can change, you may want to verify the currency of this address information using the ASSIST Online database at <http://assist.daps.dla.mil>

AMSC N/A

FSC 6140

DISTRIBUTION STATEMENT A. Approved for public release; distribution is unlimited.

MIL-PRF-32143(AT)
w/AMENDMENT 2

2.2 Government documents.

2.2.1 Specifications, standards, and handbooks. The following specifications, standards, and handbooks form a part of this document to the extent specified herein. Unless otherwise specified, the issues of these documents are those listed in the issue of the Department of Defense Index of Specifications and Standards (DoDISS) and supplement thereto, cited in the solicitation (see 6.2).

INTERNATIONAL STANDARDIZATION AGREEMENTS

STANAG 4015 - Starter Battery Spaces For Tactical Land Vehicles.

DEPARTMENT OF DEFENSE SPECIFICATIONS

MIL-C-46168 - Coating, Aliphatic Polyurethane, Chemical Agent Resistant.

MIL-C-53039 - Coating, Aliphatic Polyurethane, Single Component, Chemical Agent Resistant.

MIL-DTL-64159 - Coating, Water Dispersible Aliphatic Polyurethane, Chemical Agent Resistant.

DEPARTMENT OF DEFENSE STANDARDS

MIL-STD-810 - Environmental Engineering Considerations And Laboratory Tests.

(Copies of these documents are available online at <http://assist.daps.dla.mil/quicksearch/> or from the Standardization Document Order Desk, 700 Robbins Avenue, Building 4D, Philadelphia, PA 19111-5094.)

2.2.2 Other Government documents, drawings, and publications. The following other Government documents, drawings, and publications form a part of this performance specification to the extent specified herein. Unless otherwise specified, the issues are those cited in the solicitation.

DEPARTMENT OF TRANSPORTATION

Code Of Federal Regulations (CFR) - Title 49

(Copies of this document are available online at <http://www.gpoaccess.gov/cfr> or from the Superintendent of Documents, U.S. Government Printing Office, 732 N. Capitol Street, NW, Washington, DC 20401.)

MIL-PRF-32143(AT)
w/AMENDMENT 2

2.3 Non-Government publications. The following documents form a part of this document to the extent specified herein. Unless otherwise specified, the issues of the documents which are DoD adopted are those listed in the issue of the DoDISS cited in the solicitation. Unless otherwise specified, the issues of documents not listed in the DoDISS are the issue of the documents cited in the solicitation (**see 6.2**).

INTERNATIONAL CIVIL AVIATION ORGANIZATION (ICAO)

Technical Instructions for Safe Transportation of Dangerous Goods by Air (ICAO-TDGA)

(Copies of this document are available from ICDO, Document Sales Unit, 999 University Street, Montreal, Quebec, H3C5HT, Canada or website: www.icao.int)

SOCIETY OF AUTOMOTIVE ENGINEERS (SAE)

SAE AS478	- Identification Marking Methods (DoD Adopted)
SAE J537	- Storage Batteries (DoD Adopted)
SAE J930	- Storage Batteries for Off -Road Work Machines
SAE J1495	- Test Procedure for Battery Flame Retardant Venting Systems (DoD Adopted)

(Copies of this document are available from the Society of Automotive Engineers, Inc., 400 Commonwealth Drive, Warrendale, PA 15096 or website: www.sae.org)

2.4 Order of precedence. In the event of a conflict between the text of this document and the references cited herein, the text of this document takes precedence. Nothing in this document, however, supersedes applicable laws and regulations unless a specific exemption has been obtained.

3. REQUIREMENTS

3.1 Qualification. Batteries furnished under this specification shall be products that are authorized by the qualifying activity for listing on the applicable Qualified Products List (QPL) before contract award (**see 4.1.1 and 6.6**).

3.2 Materials and manufacturing processes. Unless otherwise specified herein, the design, materials and manufacturing process selection is the prerogative of the contractor as long as all articles submitted to the Government fully meet the operating, interface, support and ownership, and environmental requirements specified (**see 4.7**).

3.2.1 Recycled, recovered, or environmentally preferable materials. Recycled, recovered, or environmentally preferable materials should be used to the maximum extent possible, provided that the material meets or exceeds the operational and maintenance requirements, and promotes economically advantageous life cycle costs (**see 6.4.2**).

MIL-PRF-32143(AT)
 w/AMENDMENT 2

3.3 Interface and interoperability requirements. Batteries shall be designed and constructed as specified in **Figures A-2 through A-9** and the battery shall be furnished as a complete, integral assembly, with no loose parts permitted. The battery (in series connected pairs) shall be fully compatible with an on-vehicle charging voltage range of 25 – 30 volts direct current (Vdc). Battery components shall be made from acid-resistant materials (see **4.3 and 4.5.1**).

3.3.1 Containers. The battery container shall have physical requirements as specified in **3.3.1.1 through 3.3.1.4**.

3.3.1.1 Electrical breakdown. The battery container shall have no indication of perforation or burn-through when subjected to an alternating current potential of 100 V rms per 2.54×10^{-2} millimeters (mm) material thickness as specified in **4.3.1.1**.

3.3.1.2 Acid absorption. The battery container material shall exhibit no cracks or blisters, no more than 1.5 percent (%) increase in weight, and no more than 2 % increase in any physical dimension when tested as specified in **4.3.1.2**.

3.3.1.3 Impact resistance. Twenty-four hours or more after manufacture, a battery container shall remain undamaged by impacts of a 1 kilogram (kg) solid steel ball dropped from the heights indicated in **Table I** after four hours of pre-test conditioning at temperatures in **Table I** (see **4.3.1.3**).

TABLE I. Impact resistance.

Pre-test conditioning temperature	Drop height of 1 kg weight
$66^{\circ}\text{C} \pm 2^{\circ}\text{C}$	2100 mm
$-18^{\circ}\text{C} \pm 2^{\circ}\text{C}$	1400 mm
$-40^{\circ}\text{C} \pm 2^{\circ}\text{C}$	700 mm

3.3.1.4 Bulge resistance. The battery container shall exhibit no more than a 6.4 mm bulge at 93 degrees Celsius ($^{\circ}\text{C}$) $\pm 3^{\circ}\text{C}$ when filled with polyethylene glycol and measured as specified in **4.3.1.4**.

3.3.2 Battery cover. The battery cover with the venting system installed shall be flat, with no raised portions except for the terminals and shall be sealed to the container. The battery cover and battery container base shall be parallel within 1.5 mm total. The joint between the battery container and battery cover shall maintain a water-tight and air-tight seal under all test conditions specified herein. A caution and prohibition against opening and removal of vent cover(s) shall be permanently marked either on the battery cover top, or on each vent cover. The battery cover shall meet the same physical requirements as the battery container as specified in **3.3.1.1 through 3.3.1.3** (see **4.3.3.2 and 4.5.1**).

MIL-PRF-32143(AT)
w/AMENDMENT 2

3.3.3 Post seals. Post seals shall maintain an unbroken seal between the posts and the battery cover and shall maintain a water-tight and air-tight seal under all test conditions specified herein (see 4.5.1).

3.3.4 Vents. Non-removable vent assemblies or vent assembly covers shall be provided. When tested as specified in 4.3.3.1, the vent(s) shall withstand temperatures from -54°C to 91°C without cracking, melting or other damage. The vents shall not leak more than two drops of water in 10 seconds when under a 2.0 meter (m) head of water. Vents shall not permit ignition of flammable gasses when tested in accordance with SAE J1495 (see 4.3.3.2).

3.3.5 Terminal posts. Terminal posts shall be concentric tapered posts of the design and location specified on **Figures A-3 and A-6**. The positive tapered terminal post shall be identified by a "+", a "POS", or a "P" and the negative terminal by a "-", a "NEG", or an "N" as shown on **Figure A-3** (see 4.5.1).

3.3.5.1 Terminal post torque. Tapered terminal posts shall withstand torque up to 28.25 Newton-meters (Nm) applied as specified in 4.3.4 without damage to the battery.

3.3.6 Handles. Handles shall be fabricated from flexible material of the developed length specified in **Figure A-6**. Handles and attachments shall be undamaged after supporting the weight of a test battery after saturation with electrolyte and testing in accordance with 4.3.5 at temperatures of $88^{\circ}\pm 1^{\circ}\text{C}$ and $-48^{\circ}\pm 1^{\circ}\text{C}$. If knots are used to secure a plastic rope handle, they shall be attached in a manner to prevent untying, and rope ends shall be sealed to prevent fraying (see 4.5.1).

3.3.7 CARC paint and primer compatibility. When tested as specified in 4.3.6, the battery shall not be damaged or degraded by the application or over-spray of Chemical Agent Resistant Coating (CARC) paints identified under MIL-DTL-64159, MIL-C-46168 and MIL-C-53039.

3.3.8 Electrical resistance compatibility. Batteries shall have an internal resistance of 2.0 milliohms ($\text{m}\Omega$) $\pm 0.6 \text{ m}\Omega$ (see 4.3.7).

3.4 Environmental requirements.

3.4.1 Extreme temperature. Batteries shall show no cracking or other degradation of any component, and/or other damage due to temperature change between 88°C and -54°C . The reserve capacity shall not decrease more than 5% from the requirement shown in **Figure A-8** (see 4.4.1).

MIL-PRF-32143(AT)
w/AMENDMENT 2

3.4.1.1 High temperature cycling. Batteries shall withstand not less than 200 discharge/charge cycles at 65° C. The number of cycles attained by each battery shall be taken as the total actual cycles completed on high temperature cycle tests, plus each cycle attained on other tests (see **4.4.1.1** and **4.4.1.1.1**)

3.4.2 Vibration. Batteries shall maintain a steady voltage and current with no loosening of terminal posts in the cover, flooding of electrolyte at the top; inter-cell leakage; excessive sediment; broken connections; straps or plates; broken or defective separators; or other damage when tested as specified in **4.4.2**. Vibration shall not decrease the reserve capacity of batteries below that specified in **Figure A-8**.

3.5 Support or ownership requirements.

3.5.1 Identification and marking. Identification marking (see **6.2**) shall be applied to each battery with a permanent, electrolyte-resistant type decal, label or nameplate, placed on battery container as shown in **Figures A-2 through A-5**. Labels and nameplates shall be securely and permanently attached to the battery. The manufacturer's standard warning label regarding the hazards of acid and explosive gasses shall be attached in a conspicuous place on each battery (see **Figure A-3**). A specific warning label shall be attached to the battery cover prohibiting removal of the vent covers (see **Figure A-3**). A label with removable tabs for identifying the "in-service" date (month and year) shall be provided on the battery top (see **Figure A-3**). A label with the information specified in **3.5.1.1** shall be provided on the front side of the battery (see **Figure A-4**). A label shall be provided on the side designating battery identification (see **Figure A-5** and **6.5**). The lot number shall be placed on the battery top in accordance with SAE AS478 (see **4.5.1**).

3.5.1.1 Identification data. Unless otherwise specified in the contract, identification marking shall include the following:

- a. Battery identification (6TAGM or 6TGEL) (see **6.5**)
- b. Designation (Military and SAE, when applicable)
- c. Manufacturer's battery part number
- d. Voltage: 12 volts
- e. Reserve capacity at 27°C (see **Figure A-8**)
- f. Low temperature capacity at -18°C and -40°C (see **Figure A-8**)
- g. Contract or order number
- h. Date of manufacture (month and year) and lot number
- i. Manufacturer's CAGE code
- j. NSN
- k. Marked "NONSPILLABLE" or "NONSPILLABLE BATTERY"

MIL-PRF-32143(AT)
w/AMENDMENT 2

3.5.2 Workmanship. Batteries shall be processed in such a manner as to be uniform in quality and free of defects that will affect their life, serviceability, or appearance. Containers and covers shall be free of cracks, leaks, and broken parts. Marking shall be clear and distinct (see 4.5.1).

3.5.3 Special requirements for "non-spillable" batteries. Regardless of country and place of manufacture, each battery shall comply with (US) 49 CFR, and the International Civil Aviation Organization (ICAO) "Technical Instructions for the Safe Transport of Dangerous Goods by Air", in accordance with the requirements for "non-spillable" batteries. In addition, certification testing shall be performed or, with prior Government approval, certified to the test requirements of 49 CFR, Chapter 1, paragraph 173.159 (d)(3)(i) and (ii) (see 4.5.1 and 4.5.2).

3.6 Operating requirements.

3.6.1 Capacities.

3.6.1.1 Full charge capacity. Each fully charged battery shall yield a capacity of not less than that specified in **Figure A-8** when tested as specified in **4.6.1.1**.

3.6.1.2 Reserve capacity. Fully charged batteries stabilized at $27^{\circ}\pm 3^{\circ}\text{C}$ shall yield reserve capacity minutes no less than that specified in **Figure A-8** when tested as specified in **4.6.1.2**.

3.6.1.3 Low temperature capacity. Fully charged batteries, when discharged at rates specified in **Figure A-8**, shall exhibit a minimum terminal voltage of 7.2V when tested as specified in **4.6.1.3**.

3.6.1.4 Deep cycle capacity. Batteries shall withstand not less than 120 deep discharge/charge cycles. The number of cycles attained by each battery shall be taken as the total actual cycles completed on deep cycle tests, plus each cycle attained on other tests (see **4.6.1.4 and 4.6.1.4.1**).

3.6.2 Retention of charge. Following not less than 90 calendar days storage at 40°C , batteries shall yield reserve capacity minutes no less than that specified in **Figure A-8**, when tested as specified in **4.6.2**.

3.6.3 Electrolyte retention. Batteries shall not show evidence of leakage when tilted 90° and held for 30 minutes in each of two directions as specified in **4.6.3**. This test shall be performed immediately following the vibration test specified in **4.4.2**.

MIL-PRF-32143(AT)
w/AMENDMENT 2

3.6.4 Life-cycle capacity. Batteries shall withstand not less than 360 discharge/charge cycles. The life cycles attained by each battery shall be taken as the total actual cycles completed on life cycle tests, plus each cycle attained on other tests (**see 4.6.4 and 4.6.4.1**).

3.6.5 Deep discharge recovery. The battery shall meet the requirements shown in **Figure A-8** for full charge capacity, when tested as specified in **4.6.5**.

3.6.6 Overcharge/thermal runaway. When tested as specified in **4.6.6** the battery shall meet the following requirements:

- a. The current drawn during the final charge (at 14.5 ± 0.1 volts) shall not exceed 16 amperes.
- b. No flame shall issue from the battery either during or within 3 hours following the completion of testing.
- c. The battery case shall contain all debris resulting from any explosion during or after the test.
- d. There shall be no escape of electrolyte from the battery case.
- e. Venting shall occur only from the designated vent pipes.

4. VERIFICATIONS

4.1 Classification of inspections. The inspection requirements specified herein are classified as follows:

- a. Qualification inspection (**see 4.1.1**).
- b. Conformance inspection (**see 4.1.2**).
 1. Initial production inspection (IPI) (**see 4.1.2.1**).
 2. Periodic production inspection (PPI) (**see 4.1.2.2**).

4.1.1 Qualification inspection. Sample batteries and component parts shall be furnished for qualification inspection. Quantities and component parts shall be as specified in **Table II**. Qualification inspection shall consist of each and all of the testing and inspections identified in **Table III**, assignment of test samples specified in **Table IV**. Qualification inspection shall be conducted at a place designated by, or approved by, the Government. Nonconformance to any specified requirement, the failure of any test, or the presence of one or more defects shall be cause for rejection and constitute failure of qualification inspection and prohibit incorporation of product into any QPL. Unless otherwise specified in a contract or purchase order, the successful completion and approval by the Government of qualification inspection does not relieve a prospective contractor from required samples and IPI requirements from the first production lot using production design, tooling, and processes, at a location designated or approved by the Government Engineering Support Activity (ESA) (**see 3.1 and 6.6**).

MIL-PRF-32143(AT)
 w/AMENDMENT 2

4.1.2 Conformance inspection.

4.1.2.1 Initial production inspection (IPI). Unless otherwise specified in the contract or order (**see 6.2**) the contractor shall perform all IPI tests and inspections on production batteries consisting of test samples from the first production lot using production design, tooling, and processes, at a place designated or approved by ESA having approval and waiver authority. Quantities and component parts shall be as specified in **Table II**. IPI shall be conducted in accordance with the test requirements specified in **Table III**, assignment of test samples specified in **Table IV**, and the descriptive paragraphs in Section 4 of this specification. Nonconformance to any specified requirement of this specification; the failure of any test; or the presence of one or more defects shall be cause for rejection.

TABLE II. Qualification/IPI inspection samples.

Sample description	Quantity required	
	Qualification	IPI
Batteries, complete	14	14
Container	4	none
Covers (with vents)	4	1

4.1.2.2 Periodic production inspection (PPI). PPI shall be done by the contractor (with government oversight) by using one of the two following methods.

4.1.2.2.1 PPI method #1. Samples shall be selected at the rate of four fully completed batteries per each production lot. One battery will represent each group shown and shall be tested by the contractor as shown in **Table V** of each group. When production lots exceed 5000 per week, four additional test samples shall be selected and tested.

4.1.2.2.2 PPI method #2. Samples shall be selected from completed batteries each production day as detailed in **Table VI**, and tested by the contractor according to the requirements of **Table V** for each group. Once tests are successfully completed for all of each group (A, B, C, D) of **Table VI**, production lots from those days may be released prior to completion of testing on all group A batteries provided all other examinations/tests are acceptable.

4.1.2.2.3 PPI general requirements. Examination and testing for each lot shall be completed no later than 21 days from the final day of manufacture of the lot.

4.1.2.2.4 PPI failures. Failure of any sample during examination or testing may be cause for the Government to refuse to accept that lot, and subsequent lots, until it has been proven to the Government's satisfaction that appropriate corrective actions have been implemented.

**MIL-PRF-32143(AT)
 w/AMENDMENT 2**

TABLE III. Inspection requirements.

Title	Requirement	Verification	Qualification	Conformance	
				IPI	PPI
Materials and manufacturing	3.2	4.7	X		
Defects	3.3, 3.3.2, 3.3.3, 3.3.5, 3.3.6, 3.5.1, 3.5.1.1, 3.5.2 and 3.5.3	4.5.1	X		X
Interface and interoperability	3.3	4.3 & 4.5.1	X		
Containers	3.3.1				
Electrical breakdown	3.3.1.1	4.3.1.1	X		
Acid absorption	3.3.1.2	4.3.1.2	X		
Impact resistance	3.3.1.3	4.3.1.3	X		
Bulge resistance	3.3.1.4	4.3.1.4	X		
Battery cover	3.3.2	4.3.2 & 4.5.1	X		
Post seals	3.3.3	4.5.1	X	X	
Vents	3.3.4	4.3.3.1 & 4.3.3.2	X	X	
Terminal posts	3.3.5	4.5.1	X		
Terminal post torque	3.3.5.1	4.3.4	X	X	X
Handles	3.3.6	4.3.5 & 4.5.1	X		X
CARC paint and primer compatibility	3.3.7	4.3.6	X		
Electrical resistance compatibility	3.3.8	4.3.7	X	X	X
Environmental	3.4				
Extreme temperature	3.4.1	4.4.1	X	X	X
High temperature cycling	3.4.1.1	4.4.1.1 & 4.4.1.1.1	X	X	
Vibration	3.4.2	4.4.2	X	X	X
Support or ownership	3.5				
Identification and marking	3.5.1	4.5.1	X		
Identification data	3.5.1.1	4.5.1	X		
Workmanship	3.5.2	4.5.1	X	X	X
Special requirements	3.5.3	4.5.1 & 4.5.2	X		
Operating	3.6				
Capacities	3.6.1				
Full charge capacity	3.6.1.1	4.6.1.1	X	X	X
Reserve capacity	3.6.1.2	4.6.1.2	X		X
Low temperature capacity	3.6.1.3	4.6.1.3	X		X
Deep cycle capacity	3.6.1.4	4.6.1.4 & 4.6.1.4.1	X	X	
Retention of charge	3.6.2	4.6.2	X	X	
Electrolyte retention	3.6.3	4.6.3	X	X	
Life-cycle capacity	3.6.4	4.6.4 & 4.6.4.1	X		
Deep discharge recovery	3.6.5	4.6.5	X	X	
Overcharge/thermal runaway	3.6.6	4.6.6	X	X	

MIL-PRF-32143(AT)
 w/AMENDMENT 2

TABLE IV. Assignment of test samples.

Title	Sample number	Requirement	Verification
Electrical breakdown	CT1	3.3.1.1	4.3.1.1
Acid absorption	CT1/CV1	3.3.1.2	4.3.1.2
Impact resistance	CT2	3.3.1.3	4.3.1.3
Bulge resistance	CT3	3.3.1.4	4.3.1.4
Battery cover	CV2	3.3.2	4.3.2
Vents	CV3	3.3.4	4.3.3.1 & 4.3.3.2
Terminal post torque	B8	3.3.5.1	4.3.4
Handles	B8	3.3.6	4.3.5
Electrical resistance compatibility	B1-B14 (all)	3.3.8	4.3.7
Extreme temperature	B2/3	3.4.1	4.4.1
High temperature cycling	B11/8	3.4.1.1	4.4.1.1 & 4.4.1.1.1
Vibration	B1/2	3.4.2	4.4.2
Full charge capacity	B5/6	3.6.1.1	4.6.1.1
Reserve capacity	B1/2/3/4	3.6.1.2	4.6.1.2
Low temperature capacity	B1/2/3/4	3.6.1.3	4.6.1.3
Deep cycle capacity	B10/4	3.6.1.4	4.6.1.4
Retention of charge	B1	3.6.2	4.6.2
Electrolyte retention	B1	3.6.3	4.6.3
Life-cycle capacity	B7/9	3.6.4	4.6.4 & 4.6.4.1
Deep discharge recovery	B5/6	3.6.5	4.6.5
Overcharge/thermal runaway	B12/13/14	3.6.6	4.6.6

NOTE: B = Battery sample, CT = Container sample, CV = Cover sample.

MIL-PRF-32143(AT)
 w/AMENDMENT 2

TABLE V. PPI method #1.

Sample(s)	Description	Requirement	Verification
#1	<u>Group A tests:</u>		
	a. Electrical resistance compatibility	3.3.8	4.3.7
	b. Full charge capacity	3.6.1.1	4.6.1.1
	c. Extreme temperature resistance (one cycle only)	3.4.1	4.4.1
	d. Handle test (27°C only)	3.3.6	4.4.6
	e. Terminal post torque resistance	3.3.5.1	4.3.4
	f. Workmanship	3.5.2	4.5.1
#2	<u>Group B tests:</u>		
	a. Electrical resistance compatibility	3.3.8	4.3.7
	b. Low temperature capacity (-40°C only)	3.6.1.3	4.6.1.3
	c. Workmanship	3.5.2	4.5.1
#3	<u>Group C tests:</u>		
	a. Electrical resistance compatibility	3.3.8	4.3.7
	b. Reserve capacity	3.6.1.2	4.6.1.2
	c. Vibration	3.4.2	4.4.2
	d. Workmanship	3.5.2	4.5.1
#4	<u>Group D tests:</u>		
	a. Electrical resistance compatibility	3.3.8	4.3.7
	b. Vibration	3.4.2	4.4.2
	c. Reserve capacity	3.6.1.2	4.6.1.2
	d. Extreme temperature resistance (one cycle only)	3.4.1	4.4.1
		f. Workmanship	3.5.2

TABLE VI. PPI method #2.

Day	Weekly production test group	Batteries
First	B, C	2
Second	B, D	2
Third	A	1
Fourth	A	1
Fifth	A	1
Sixth	A	1
Seventh	A	1

MIL-PRF-32143(AT)
w/AMENDMENT 2

4.2 Test conditions, schedules, special requirements and prohibitions.

4.2.1 Test conditions and tolerances for test conditions. Unless otherwise specified herein, all testing and examinations shall be conducted IAW the paragraphs on Standard Ambient Test Conditions and Tolerances for Test Conditions in Part One of MIL-STD-810, and SAE J537. The contractor or test activity may use, with prior Government permission, observations and test results obtained using actual on-site conditions that are recorded as actual and corrected values to +25°C and the humidity and barometric pressure ranges allowed in the preceding sentence.

4.2.2 Schedule and sequence of tests. The order of testing for IPI will be established by the contractor and shall be approved by the Army ESA prior to start of any testing by the contractor. Advance planning and provisions shall be made to insure that each item of the test schedule and sequence shall not have a detrimental effect or preclude the performance of a subsequent test/examination on any test sample.

4.2.3 Advance notice of schedule. Appropriate advance notice of the test schedule, location(s), or changes shall be provided to the Government, contractor, designated test site/facility, and regulatory agency personnel to allow participation or oversight by each.

4.2.4 Prohibitions. The following are specifically prohibited.

- a. Lot sampling, Acceptable Quality Limits (AQL), or similar inspection and testing schemes/methods.
- b. Modeling and simulation for all tests and demonstrations.

4.2.5 Calibration of test equipment. Measuring equipment, fixtures, and additional electrical equipment required for battery testing shall meet or exceed the verifiable values stated by the Original Equipment Manufacturer (OEM) of the equipment, and the readable portion of the gauge or recording device (scales) shall not be less than the industry standard increments for the anticipated range of values and types of values for each test or series of tests.

4.2.6 Discharging and charging of test batteries.

4.2.6.1 Discharging. The fully charged battery shall be at a temperature of $27^{\circ} \pm 3^{\circ}\text{C}$ and shall be discharged at the 20 hour rate (the current in amperes equal to 1/20th of the battery's rated ampere hour capacity, also know as the C/20 Rate), to a final average terminal voltage equivalent to 1.75 V per cell, or 10.5 V total, unless otherwise specified.

4.2.6.2 Charging. The battery temperature is to be stabilized at $+25^{\circ}\text{C} \pm 5^{\circ}\text{C}$ before charging commences. Batteries shall be charged using a constant voltage of $14.25 + .50/-0.25$ V. The charge is to be terminated when the charge current decreases to less than 250 milliamps and remains constant or declines for three consecutive hourly readings or to 150% recharge.

MIL-PRF-32143(AT)
w/AMENDMENT 2

4.2.6.3 Periodic recharging. If the testing on any activated battery is temporarily stopped for a period of 72 hours or more, the battery shall be given a freshening charge in accordance with the Government-approved contractor's procedures at the specified rate until fully charged (see 4.3.2) before testing is resumed. A test battery shall not be stored for more than 24 hours after a discharge without being recharged.

4.3 Interface and interoperability requirements verification. The general requirements of 3.3 shall be verified and demonstrated by tests and inspection of contractor records providing objective quality evidence that the design, construction, processing, and materials conform to requirements of this specification. Applicable records shall include one or more of the following: drawings, specifications, design data, receiving inspection records, processing and quality control standards, vendor catalogs and certifications, industry standards, test reports, and rating data.

4.3.1 Container tests.

4.3.1.1 Electrical breakdown test. To determine conformance to 3.3.1.1, the battery container (see 3.3.1) shall be filled with lead or aluminum shot or fitted with a close fitting mandrel or other electrode to within 12.5 mm of the top of the lowest point on the sides, ends, or partitions of the containers. An alternating current potential of 100 V rms per 2.54×10^{-2} mm of thickness shall be applied for 15 seconds after full calculated voltage has been reached. Voltage shall be supplied by a transformer of not less than 1/2 kilo-volt-ampere capacity, using the electrodes in a manner that will subject each outer wall and inner partition of the container to the electrode potential. Containers shall subsequently be examined for leaks, imperfections, or other evidence of perforation or burn-through.

4.3.1.2 Acid absorption test. To determine conformance to 3.3.1.2, two specimens, each 76 by 76 mm, shall be cut from the partitions of the container. After being measured with calipers and weighted in the dry condition at $27^{\circ} \pm 6^{\circ}\text{C}$, each specimen shall be immersed in a covered vessel containing 150 cubic centimeters (cc) of electrolyte with a minimum of 37.5% sulfuric acid, Chemical Abstract Service # 7664-93-9. The electrolyte shall have a specific gravity in the range of 1.3945 to 1.4042 at 15.6°C . The vessel shall be held for seven days in an oven at $66^{\circ}\text{C} \pm 3^{\circ}\text{C}$. At the end of the heating period, the specimens shall be inspected for evidence of cracks or blisters and then measured and weighed. The percentage increase in dimensions and weight shall be calculated.

4.3.1.3 Impact resistance test. To determine conformance to 3.3.1.3, an undamaged specimen container shall be permitted to rest no less than 24 hours after manufacture. Before testing, the sample shall be conditioned for four hours at each test temperature. The test temperatures shall be $66^{\circ} \pm 2^{\circ}\text{C}$, $-18^{\circ} \pm 2^{\circ}\text{C}$, and $-40^{\circ} \pm 2^{\circ}\text{C}$. Impact resistance shall be determined by a 1 kg solid steel ball, used as a free falling weight. The impact resistance shall

MIL-PRF-32143(AT)
w/AMENDMENT 2

be found by dropping the weight at the height necessary to produce the minimum impact resistance requirement for the test temperature (see **Table I**). The weight shall hit the container only once for each drop. During the test, the container shall be positioned on a flat steel plate, about 25 mm longer and wider than the container. The container shall be positioned in such a manner that the ball will strike 1/3 down from the top of the container on the centerline of the sides of each cell and on the center of each cell cover area (where thickness is uniform). Testing of post cells is not required. Any cracking or deformation of the container shall constitute failure.

4.3.1.4 Bulge resistance test. To determine conformance to **3.3.1.4**, the bulge resistance of the container shall be measured and determined as follows:

- a. Place an empty container, to be tested, in an appropriate rigid metal tray.
- b. Fill the container to within 25 mm of the top with commercial grade polyethylene glycol at a temperature of $93^{\circ} \pm 3^{\circ}\text{C}$.
- c. Place the tray, containing the container, to be tested, in an oven and maintain the polyethylene glycol at $93^{\circ} \pm 3^{\circ}\text{C}$.
- d. When the liquid in the end cell adjacent to the end wall, to be measured, reaches a temperature of $93^{\circ} \pm 3^{\circ}\text{C}$, start a one hour soak time.
- e. At the end of the soak period, remove the tray containing the container being tested, from the oven and within five minutes, measure the end wall bulge, using the slider arrangement. The polyethylene glycol is to remain in the test container until the completion of the measurements.
- f. The bulge shall be determined by comparing the center of the end wall with the plane of the four corners exposed. The center of the end wall is defined as a point halfway between the horizontal parting line at the bottom and the bottom of the top band.
- g. Bulge is to be reported as the difference as determined in subparagraph f. Bulge in excess of 6.3 mm constitutes failure.

4.3.2 Battery cover tests. To determine conformance to **3.3.2**, battery covers shall be tested as specified in **4.3.1.1** through **4.3.1.3** with appropriate modifications in samples and procedures. Results shall be evaluated as specified in referenced paragraphs.

4.3.3 Vent tests.

4.3.3.1 Vent thermal resistance and water pressure test. To determine conformance to **3.3.4**, each vent plug from the battery under test (see **Figure A-8**) shall be placed in an ambient air temperature of $-48^{\circ} \pm 1^{\circ}\text{C}$ for two hours. At the end of the cooling period, the plugs shall be removed and immediately placed in an oven at an ambient air temperature of $91^{\circ} \pm 3^{\circ}\text{C}$ for 90 minutes. They shall then be removed and inspected for evidence of damage such as cracking or melting. After a cooling period of one hour, each vent shall be inserted in a fixture arranged

MIL-PRF-32143(AT)
w/AMENDMENT 2

so that water pressure can be applied on the outside of the battery, and air pressure on the lower side. Using this fixture, the upper side of each vent shall be subjected to a water pressure which exceeds the air pressure on the lower side by 12.07 kPa (water head of 2.0 meters if air pressure is atmospheric). The number of drops of water that leaks through each vent/filler plug and the time required therefore (not to be less than one minute) shall be recorded.

4.3.3.2 Flame retardation test. To determine conformance to **3.3.4**, battery and vent(s) shall be tested for flame retardation in accordance with SAE J1495.

4.3.4 Terminal post torque test. To determine conformance to **3.3.5.1**, an increasing torque up to 28.25 Newton-meters (N-m) shall be applied in a direction perpendicular to the axis of the terminal posts and parallel to the top of the battery by a torque indicating device, through a fitting battery terminal or other clamping device. Observation shall be made for evidence of distortion of the strap and connected plates, or of the seal between the posts and the cell cover.

4.3.5 Handle test. To determine conformance to **3.3.6**, the handle and bond areas shall be saturated with an electrolyte with a minimum of 37.5% sulfuric acid, Chemical Abstract Service # 7664-93-9, and air dried twice daily for two days. The electrolyte shall have a specific gravity in the range of 1.3945 to 1.4042 at 15.6°C. The handles and bond areas shall again be saturated with electrolyte and the battery placed in an ambient air temperature of $88^{\circ} \pm 1^{\circ}\text{C}$ for 60 minutes, allowed to cool to room temperature, and again heated at $88^{\circ} \pm 1^{\circ}\text{C}$ for 60 minutes. The battery shall then be removed from the oven and immediately placed in a test fixture similar to **Figure A-1**. The battery shall be initially set on the removable support, and the angles and initial tautness of the handles shall be set with the support in place. The ballast weight, equal to the weight of the test battery, shall be placed on top of the battery. The support shall then be slowly removed and the battery and weight be allowed to hang freely by the handles for 60 seconds. The battery shall then be removed and the handles and bond shall be examined for conformance to **3.3.6**. After the battery has been placed in an ambient air temperature of $-48^{\circ} \pm 1^{\circ}\text{C}$ for 24 hours, the test shall be repeated at $-48^{\circ} \pm 1^{\circ}\text{C}$.

4.3.6 CARC paint and primer tests. To determine conformance to **3.3.7**, the exterior surfaces and mating joints of empty containers and covers, or sample coupons of production container and cover materials, shall be coated with CARC paint and primers in accordance with MIL-DTL-64159, MIL-C-46168 and MIL-C-53039. The exterior surfaces and mating joints of the test samples shall be examined to assure that no surface or mating joint demonstrates joint sealing failures, interior deformation, surface degradation, or shrinkage has occurred as a result of the CARC exposure/coating after 12, 24, 72, and 168 hour periods.

4.3.7 Electrical resistance compatibility test. To determine conformance to **3.3.8** specimens shall be tested with a commercially available meter, and shall exhibit an internal resistance of 2.0 milliohms ($\text{m}\Omega$) \pm 0.6 $\text{m}\Omega$.

MIL-PRF-32143(AT)
w/AMENDMENT 2

4.4 Environmental requirements verification.

4.4.1 Extreme temperature test. To determine conformance to **3.4.1**, batteries shall be subjected to two thermal shock cycles. The following procedure for one cycle shall be used:

- a. Perform reserve capacity test per **4.6.1.2**.
- b. Battery shall be placed in an ambient air temperature of $-54^{\circ} \pm 1^{\circ}\text{C}$ for 24 hours, or until battery is stabilized.
- c. The battery shall then be placed in an ambient air temperature of $88^{\circ} \pm 1^{\circ}\text{C}$ for 24 hours.
- d. The battery shall be allowed to cool gradually to $27^{\circ} \pm 3^{\circ}\text{C}$ for 24 hours.
- e. Perform reserve capacity test per **4.6.1.2**, decrease in reserve capacity of more than 5% constitutes a failure.

4.4.1.1 High temperature cycling test. To determine conformance to **3.4.1.1**, high temperature cycling shall consist of a series of discharge and charge cycles. Immediately prior to the beginning of the test, the battery shall be fully charged as specified in **4.2.6.2**. Tests shall be performed with the battery in an environmental chamber with the temperature maintained at $65^{\circ} \pm 3^{\circ}\text{C}$. When the ampere-hour capacity equals or drops below 40% of the rated ampere-hour capacity during the high temperature discharge test cycle, the battery shall be fully charged as specified in **4.2.6.2** and tested as specified in **4.6.1.1**. If the capacity is above 40% of normal full charged value, the life test shall be continued. If the capacity equals or falls below 40%, the life cycle test shall be terminated. The life cycle attained by a battery shall be taken as the total of the actual cycles completed on the life test, plus each cycle received on other tests.

4.4.1.1.1 High temperature discharge cycles. To determine conformance to **3.4.1.1**, the test shall consist of a series of discharge/charge cycles as follows:

- a. Normal cycles. The normal cycles shall consist of a series of six hour cycles (four cycles per day or approximately 24 per week). Each cycle shall consist of discharge for one hour at 40 amperes and charge for five hours at 14.25 V.
- b. Weekly capacity discharge cycles. Ampere hour capacity shall be determined at the completion of each series of 24 normal cycles. The battery shall be discharged at the ampere rate for normal cycles, until a final average terminal voltage of 1.75 volts per cell has been reached. The ampere hour capacity shall be calculated as the product of the current rate in amperes and the time of discharge in hours. Following this discharge, the battery shall be fully charged per **4.2.6.2** (except at $65^{\circ} \pm 3^{\circ}\text{C}$) and the normal cycle procedure shall be continued. The battery shall be placed on a discharge cycle which, with the charge cycle, shall constitute a full normal cycle.

MIL-PRF-32143(AT)
w/AMENDMENT 2

4.4.2 Vibration test. To determine conformance to **3.4.2**, the test specimen shall be stabilized, then subjected to the reserve capacity test per **4.6.1.2 a, b, and c**, in an ambient air temperature of $27^{\circ} \pm 3^{\circ}\text{C}$ prior to vibration. Apparatus shall include a hold down frame to bear on the top edges of the battery container, but not on the terminal posts. While in an ambient air temperature of $27^{\circ} \pm 3^{\circ}\text{C}$ and mounted in the vibrating machine, the specimen shall be vibrated for two hours at a frequency of 2000 to 2100 cycles per minute through an amplitude of 1.14 to 1.27 mm (total vertical excursion 2.28 to 2.54 mm). During this test the battery shall be discharged at the 20 hour rate. The test shall be repeated for one hour, except that the battery shall be chilled to, and the electrolyte stabilized at a temperature of $-40^{\circ} \pm 2^{\circ}\text{C}$ for one hour immediately before beginning vibration. During the test, the battery shall be observed for maintenance of steady voltage and current, and thereafter examined for evidence of loosening of terminal posts in the covers and flooding of electrolyte at the top. The battery shall be removed from the vibrating machine, allowed to warm to $27^{\circ} \pm 3^{\circ}\text{C}$ until the electrolyte is stabilized, then subjected to **4.6.1.2 a, b, and c**. Or the vibration testing may be done in accordance with SAE J930.

4.5 Support or ownership requirements verification.

4.5.1 Defects. Conformance to **3.3, 3.3.2, 3.3.3, 3.3.5, 3.3.6, 3.5.1, 3.5.2 and 3.5.3** shall be determined by examination and testing for the defects. Examination shall be visual or by measurement with standard inspection equipment.

4.5.2 Special requirements for "non-spillable" batteries. A contractor-generated CoC with supporting evidence may be acceptable to the ESA (PCO) in lieu of the testing required by **3.5.3** if such certification has been performed and approved by the Army ESA office or another non-DoD Government activity within twelve (12) calendar months prior to award of the contract or initial delivery order by the procuring activity. In the absence of an ESA acceptable CoC, and in addition to any other test requirements of the IPI, the contractor shall provide and test six (6) additional batteries, as identified in a. and b. below.

- a. Three (3) each, vibration test in accordance with 49 CFR, Chapter 1, paragraph 173.159(d)(3)(i).
- b. Three (3) each, pressure differential test in accordance with 49 CFR, Chapter 1, paragraph 173.159(d)(3)(ii).

MIL-PRF-32143(AT)
w/AMENDMENT 2

4.6 Operating requirements verification.

4.6.1 Capacities.

4.6.1.1 Full charge capacity test at 27°C. To determine conformance to **3.6.1.1**, the battery full charge capacity rating (ampere-hours) shall be determined as follows:

- a. Charge battery in accordance with **4.2.6.2** before each discharge.
- b. The temperature of the battery at the beginning of each discharge shall be $27^{\circ}\pm 3^{\circ}\text{C}$, and the temperature shall be maintained within this range by means of a water bath, or controlled air temperature condition, during discharge.
- c. Discharge battery in accordance with **4.2.6.1** to a terminal voltage of 10.5 volts. Record the discharge time, and calculate the ampere-hour capacity.
- d. Two (2) additional attempts are permitted of a through c to meet amp-hr capacity requirements.
- e. The ampere-hour capacity obtained from each battery subjected to steps c or d shall represent the full charge capacity. Exception: If the ampere-hour capacity is met in step c or d, extra steps are not required.

4.6.1.2 Reserve capacity test. To determine conformance to **3.6.1.2**, reserve capacity tests shall be conducted as follows:

- a. Charge battery in accordance with **4.2.6.2** before each discharge.
- b. The temperature of the battery at the beginning of each discharge shall be $27^{\circ} \pm 3^{\circ}\text{C}$, and the temperature shall be maintained within this range by means of a water bath, or controlled air temperature condition, during discharge.
- c. Discharge battery at 25 ± 0.25 amperes to a terminal voltage of 10.5 volts. Record the time of discharge in minutes.
- d. Two (2) additional attempts of a thru c are permitted to meet reserve capacity requirement.
- e. The longest time of discharge obtained from each battery subjected to steps c, d, and e shall represent the reserve capacity of the battery. Exception: If the reserve capacity requirement is met in step c or d, remaining steps through step e are not required.

4.6.1.3 Low temperature capacity test. To determine conformance to **3.6.1.3**, the test for high discharge rate at -18°C and -40°C shall be performed as follows:

- a. Charge battery in accordance with **4.2.6.2**.
- b. Place battery in cold chamber having a temperature of $-40^{\circ} \pm 3^{\circ}\text{C}$.
- c. When the battery has stabilized for one hour at $-40^{\circ} \pm 3^{\circ}\text{C}$ immediately after removing from the cold chamber, the battery shall be discharged at the rate and time specified in **Figure A-8**.

MIL-PRF-32143(AT)
w/AMENDMENT 2

- d. At this time the voltage shall be measured to determine conformance to **3.6.1.3**.
- e. If a battery fails the test, it shall be retested. The retested battery shall be charged, discharged, and recharged again; all in accordance with **4.2.6**. With electrolyte stabilized at $27^{\circ} \pm 3^{\circ}\text{C}$, the battery will be retested as specified in a through d. Failure of a battery to pass this second cycle shall be considered as failure to meet the specified requirements.
- f. Test as per **4.6.1.2**.
- g. Repeat steps a through e, except temperature shall be $-18^{\circ} \pm 1^{\circ}\text{C}$ and discharge rate shall be at the rate and time specified in **Figure A-8**.

4.6.1.4 Deep cycle capacity test. To determine conformance to **3.6.1.4**, life tests shall consist of a series of discharge and charge cycles. Immediately prior to the beginning of the test, the battery shall be fully charged as specified in **4.2.6.2**. Tests shall be performed with the battery in a water bath with the temperature maintained at $38^{\circ} \pm 3^{\circ}\text{C}$. When the ampere-hour capacity equals or drops below 70% of the rated ampere-hour capacity during the deep discharge cycle, (see **4.6.1.4.1**) the battery shall be fully charged as specified in **4.2.6.2** and tested as specified in **4.6.1.1**. If the capacity is above 70% of normal full charged value, the life test shall be continued. If the capacity equals or falls below 70%, the life test shall be terminated. The life cycle attained by a battery shall be taken as the total of the actual cycles completed on the life test, plus each cycle received on other tests.

4.6.1.4.1 Deep discharge cycles. To determine conformance to **3.6.1.4**, the test shall consist of a series of discharge/charge cycles as follows:

- a. Normal cycles. Each cycle shall consist of discharge for one hour at 40 amperes, followed by a continuation discharge of 15 amperes until a final average terminal voltage of 1.75 volts per cell has been reached, then charged at 14.25 V for 10 hours, or until the charge current decreases to 0.15 amperes.
- b. Capacity discharge cycles. Ampere hour capacity shall be determined at the completion of each series of 10 normal cycles. The battery shall be discharged at 40 amperes until a final average terminal voltage of 1.75 volts per cell has been reached. The ampere hour capacity shall be calculated as the product of the current rate in amperes and the time of discharge in hours. Following this discharge, the battery shall be fully charged per **4.2.6.2** (except at $38^{\circ} \pm 3^{\circ}\text{C}$) and the normal cycle procedure shall be continued. The battery shall be placed on a discharge cycle which, with the charge cycle, shall constitute a full normal cycle.

4.6.2 Retention of charge test. To determine conformance to **3.6.2**, the retention of charge test shall be performed as follows:

- a. Charge battery as specified in **4.2.6.2**.
- b. Perform three (3) reserve capacity tests in accordance with **4.6.1.2**.
- c. Charge battery as specified in **4.2.6.2**.

MIL-PRF-32143(AT)
w/AMENDMENT 2

- d. Place the battery in a circulating water bath or environmental chamber maintained at $40^{\circ} \pm 3^{\circ}\text{C}$ for ninety (90) calendar days.
- e. After ninety (90) calendar days, remove the battery from the water bath and cool it to $27^{\circ} \pm 3^{\circ}\text{C}$ within 48 hours after removal from the bath.
NOTE: DO NOT RECHARGE BATTERY PRIOR TO NEXT STEP.
- f. Perform reserve capacity test per **4.6.1.2**.

4.6.3 Electrolyte retention test. To determine conformance to **3.6.3**, the batteries shall be tilted through a 90 degrees ($^{\circ}$) angle from a plane normal to the bottom of the battery along the major axis, held thus for 30 minutes and then similarly tilted and held along the minor axis. Batteries shall be observed for evidence of leakage, or spillage of electrolyte. No leakage is permissible. This test is to be performed immediately following the vibration test specified in **4.4.2**.

4.6.4 Life-cycle capacity tests. To determine conformance to **3.6.4**, life tests shall consist of a series of discharge and charge cycles. Immediately prior to the beginning of the test, the battery shall be fully charged as specified in **4.2.6.2**. Tests shall be performed with the battery in a water bath with the temperature maintained at $38^{\circ} \pm 3^{\circ}\text{C}$. When the ampere-hour capacity equals or drops below 40% of the rated ampere-hour capacity during the life capacity discharge cycle, (see **4.6.4.1**) the battery shall be fully charged as specified in **4.2.6.2** and tested as specified in **4.6.1.1**. If the capacity is above 40% of normal full charged value, the life test shall be continued. If the capacity equals or falls below 40%, the life cycle test shall be terminated. The life cycle attained by a battery shall be taken as the total of the actual cycles completed on the life test, plus each cycle received on other tests.

4.6.4.1 Life capacity discharge cycles. To determine conformance to **3.6.4**, the test shall consist of a total of 360 discharge/charge cycles including cycles attained on other tests and normal and weekly cycles, as follows:

- a. Normal cycles. The normal cycles shall consist of a series of six hour cycles (four cycles per day or approximately 24 per week). Each cycle shall consist of discharge for one hour at 40 amperes and charge for five hours at 14.25 V.
- b. Weekly capacity discharge cycles. Ampere hour capacity shall be determined at the completion of each series of 24 normal cycles. The battery shall be discharged at the ampere rate for normal cycles, until a final average terminal voltage of 1.75 volts per cell has been reached. The ampere hour capacity shall be calculated as the product of the current rate in amperes and the time of discharge in hours. Following this discharge, the battery shall be fully charged per **4.2.6.2** (except at $38^{\circ} \pm 3^{\circ}\text{C}$) and the normal cycle procedure shall be continued. The battery shall be placed on a discharge cycle which, with the charge cycle, shall constitute a full normal cycle.

MIL-PRF-32143(AT)
w/AMENDMENT 2

4.6.5 Deep discharge recovery. To determine conformance to **3.6.5**, use the following procedure in a temperature controlled area at $27^{\circ} \pm 3^{\circ}\text{C}$ to determine compliance.

- a. Charge the battery according to **4.2.6.2**.
- b. Discharge in accordance with **4.2.6.1**.
- c. Without recharging the battery, connect a resistor of 1 ohm between the battery terminals and store for 30 days in a temperature controlled area.
- d. On the 31st day, remove the resistor and immediately recharge the battery at 15 volts, using a charger that provides a current not less than 50 amps.
- e. Record the maximum amps that the battery accepted within 24 hours.
- f. Finish recharging the battery according to **4.2.6.2**.
- g. Perform one (1) full charge capacity test per **4.6.1.1** (see **Fig. A-8**).

4.6.6 Induced destructive overcharge test. **WARNING: There is a possible risk of fire or explosion involved in performing this test.** To determine conformance to **3.6.6**, the battery shall be fully charged per **4.2.6.2**, then it shall be further charged using a constant voltage power supply at a minimum of 3 volts per cell with the capability of supplying a current of at least 300 amps. A thermal runaway condition is to be induced and sustained to the point of total battery failure. Thermal runaway is indicated by:

- a. A rise followed by a significant fall in the charging current drawn by the battery.
- b. A substantial rise in the temperature of the battery.

The battery terminal voltage, charging current, and battery temperature shall be recorded throughout the test.

After the thermal runaway has ended, (i.e. after the charging current has diminished) let the battery rest open circuit for one hour, then charge the battery at a constant 14.5 +/- 0.1 volts for at least 30 minutes. The test shall be considered failed if the following criteria are not met:

- a. The current drawn during the final charge (at 14.5 +/- 0.1 volts) shall not exceed 16 amperes.
- b. No flame shall issue from the battery either during or within 3 hours following the completion of testing.
- c. The battery case shall contain all debris resulting from any explosion during or after the test.
- d. There shall be no escape of electrolyte from the battery case.
- e. Venting shall occur only from the designated vent pipes.

4.7 Materials and manufacturing processes verification. Conformance to 3.2 shall be verified and demonstrated by inspection of contractor records providing objective quality evidence or certification that design, construction, processing, and materials conform to requirements. Applicable records shall include drawings, specifications, design data, receiving

MIL-PRF-32143(AT)
w/AMENDMENT 2

inspection records, processing and quality control standards, vendor catalogs and certifications, industry standards, test reports, and rating data.

5. PACKAGING

5.1 Packaging. For acquisition purposes, the packaging requirements shall be as specified in the contract or order (see 6.2). When actual packaging of material is to be performed by DoD personnel, these personnel need to contact the responsible packaging activity to ascertain requisite packaging requirements. Packaging requirements are maintained by the Inventory Control Point's packaging activity within the Military Department or Defense Agency, or within the Military Department's System Command. Packaging data retrieval is available from the managing Military Department or Defense Agency's automated packaging files, CD-ROM products, or by contacting the responsible packaging activity.

6. NOTES

6.1 Intended use. Batteries covered by this performance specification are intended primarily for starting, lighting, and ignition service in military vehicles of all types, internal combustion engine driven industrial trucks and tractors, construction equipment and generator sets. The batteries will also be used for radio operation and as a source of electrical energy for operating vehicular accessories, such as sighting and target ranging devices and control mechanisms. The battery's size and shape is controlled by a NATO Standardization Agreement (see 6.7), and batteries of this form factor are uniquely used by the military.

6.2 Acquisition requirements. Acquisition documents must specify the following:

- a. Title, number and date of this specification.
- b. Issue of DoDISS to be cited in the solicitation, and if required, the specific issue of individual documents referenced (see 2.2.1 and 2.3).
- c. Any special marking requirements above those already specified by this specification (see 3.5.1).
- d. If IPI is not required (see 4.1.2.1).
- e. Special packaging requirements, other than those specified (see 5).

6.3 Subject term (key word) listing.

Acid resistance
Atmospheric pressure
Cold cranking amperes
Maintenance-free
Thermoplastic material

MIL-PRF-32143(AT)
w/AMENDMENT 2

6.4 Definitions.

6.4.1 Definitions of terms used in inspection:

- a. Defective. A defective is a unit of product which contains one or more defects.
- b. Formation of lots or batches. The product should be assembled into identifiable lots, sub-lots, batches, or in such other manner as may be prescribed. Each lot or batch should, as far as is practicable, consist of units of product of a single type, grade, class, size and composition, manufactured under essentially the same conditions, and at essentially the same time.
- c. Lot or batch. The term lot or batch should mean "inspection lot" or "inspection batch", i.e., a collection of units or product from which a sample is to be drawn and inspected and may differ from a collection of units designated as a lot or batch for other purposes (e.g., production, shipment, etc.).
- d. Lot or batch size. The lot or batch size is the number of units of product in a lot or batch.
- e. Presentation of lots or batches. The formation of the lots or batches, lot or batch size, and the manner in which each lot or batch is to be presented and identified by the supplier should be designated or approved by the responsible authority. As necessary, the supplier shall provide adequate and suitable storage space for each lot or batch, equipment needed for proper identification and presentation, and personnel for all handling of product required for drawing of samples.
- f. Sample. A sample consists of one or more units of product drawn from a lot or batch, the units of the sample being selected at random without regard to their quality. The number of units or product in the sample is the sample size.
- g. Time of sampling. Samples may be drawn after all the units comprising the lot or batch have been assembled, or samples may be drawn during assembly of the lot or batch.

6.4.2 Recovered materials. "Recovered materials" means materials that have been collected or recovered from solid waste (see 3.2.1 and 6.4.3).

6.4.3 Solid waste. "Solid wastes" means (a) any garbage, refuse, or sludge from a waste treatment plant, water supply treatment plant, or air pollution control facility; and (b) other discarded material, including solid, liquid, semi-solid, or contained gaseous material resulting from industrial, commercial, mining and agricultural operations, and from community activities. It does not include solid or dissolved material in domestic sewage, or solid or dissolved material in irrigation return flows or industrial discharges which are point sources subject to permits under section 402 of the Clean Water Act (33 U.S.C. 1342 et seq.), or source, special nuclear, or by-product material and defined by the Atomic Energy Act of 1954 (42 U.S.C. 2011 et seq.) (Source: Federal Acquisition Regulations, section 23.402).

MIL-PRF-32143(AT)
w/AMENDMENT 2

6.5 Battery identification. Batteries identification designations are “6TAGM” for Absorbed Glass Mat type batteries and “6TGEL” for gelled electrolyte type batteries (see 3.5.1.1a and Figure A-5).

6.6 Qualification. With respect to products requiring qualification, awards will be made only for products which are, at the time of award of contract, qualified for inclusion in QPL-32143 whether or not such products have actually been so listed by that date. The attention of the contractors is called to these requirements, and manufacturers are urged to arrange to have the products that they propose to offer to the Federal Government tested for qualification in order that they may be eligible to be awarded contracts or orders for the products covered by this specification. Information pertaining to qualification of products may be obtained from U.S. Army Tank-automotive and Armaments Command, ATTN: AMSARD-TAR-E/ASI, (MS #268), Warren, MI 48397-5000.

6.7 International standardization agreement implementation. This specification implements (STANAG 4015 “Starter Battery Spaces For Tactical Land Vehicles”). When amendment, revision, or cancellation of this specification is proposed, the preparing activity must coordinate the action with the U.S. National Point of Contact for the international standardization agreement, as identified in the ASSIST database at www.dodssp.daps.mil .

6.8 Qualification/ IPI and other test report submittals. Defense Contract Management Command (DCMC) oversight is required including comments and/or concurrence on the contractor’s qualification report prior to submittal to the Procurement Contracting Officer (PCO).

6.9 Instruction tags and labels. Requirements for instruction tags and labels providing complete information for placing battery in service, operation and charging should be requested in the contract or order. These tags and labels should be attached in a conspicuous place on each battery.

6.10 Amendment notations. The margins of this specification are marked with vertical lines to indicate modifications generated by this amendment. This was done as a convenience only and the Government assumes no liability whatsoever for any inaccuracies in these notations. Bidders and contractors are cautioned to evaluate the requirements of this document based on the entire content irrespective of the marginal notations.

6.11 Dimension changes. Throughout the last 30 years the specifications have become unaligned with the NATO specification. The dimensions have been changed to bring the 6T battery back into NATO specifications.

MIL-PRF-32143(AT)
w/AMENDMENT 2
APPENDIX A

INSPECTION VERIFICATION CHARACTERISTICS OF A
VALVE REGULATED LEAD ACID, STORAGE BATTERY

A.1 SCOPE

A.1.1 Scope. The appendix details the physical, environmental and performance of the VRLA storage ("Maintenance-Free") battery. This appendix is a mandatory part of this specification.

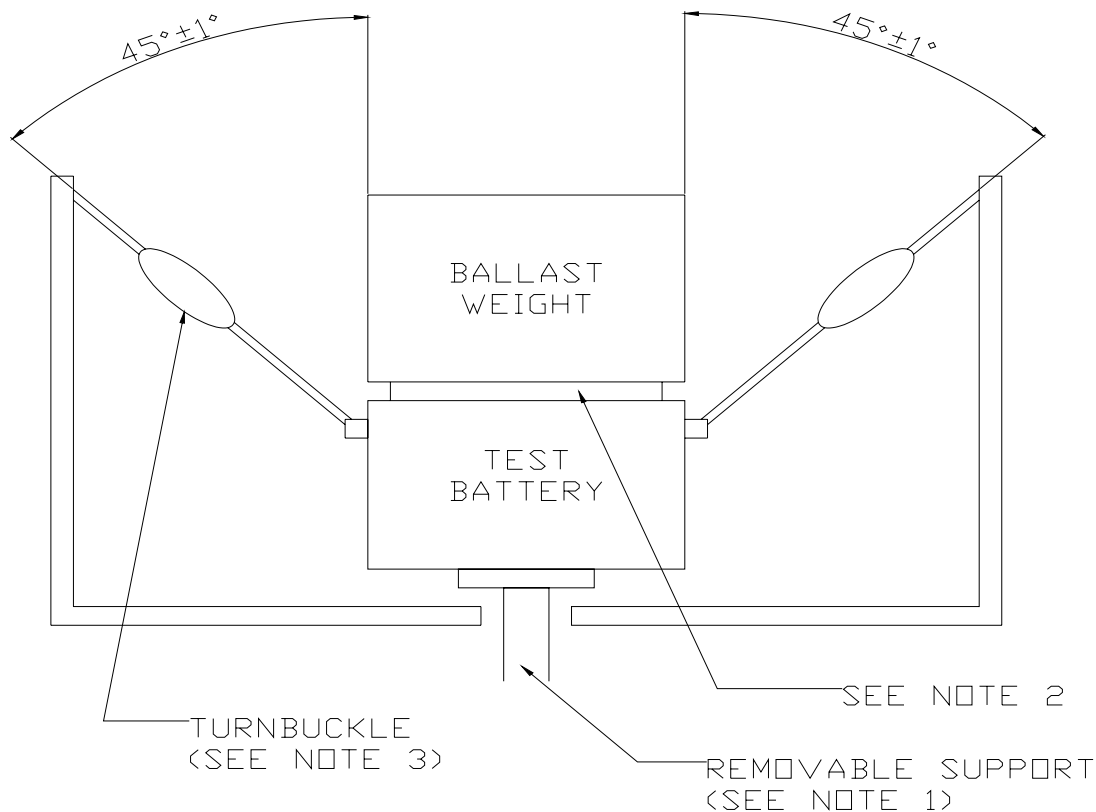

NOTES:

1. Support shall allow gradual and even removal so as to minimize shock and insure even loading of both handles.
2. A lightweight (less than 1 kg) shim may be used between battery and weight to prevent damage to caps, posts or cover.
3. Turnbuckles shall be used to establish 45° angles of handles with test weight applied after removal of support. Turn buckles shall include a device to support rope handles over a length of 112 mm during test.

FIGURE A-1. Handle test.

MIL-PRF-32143(AT)
w/AMENDMENT 2
APPENDIX A

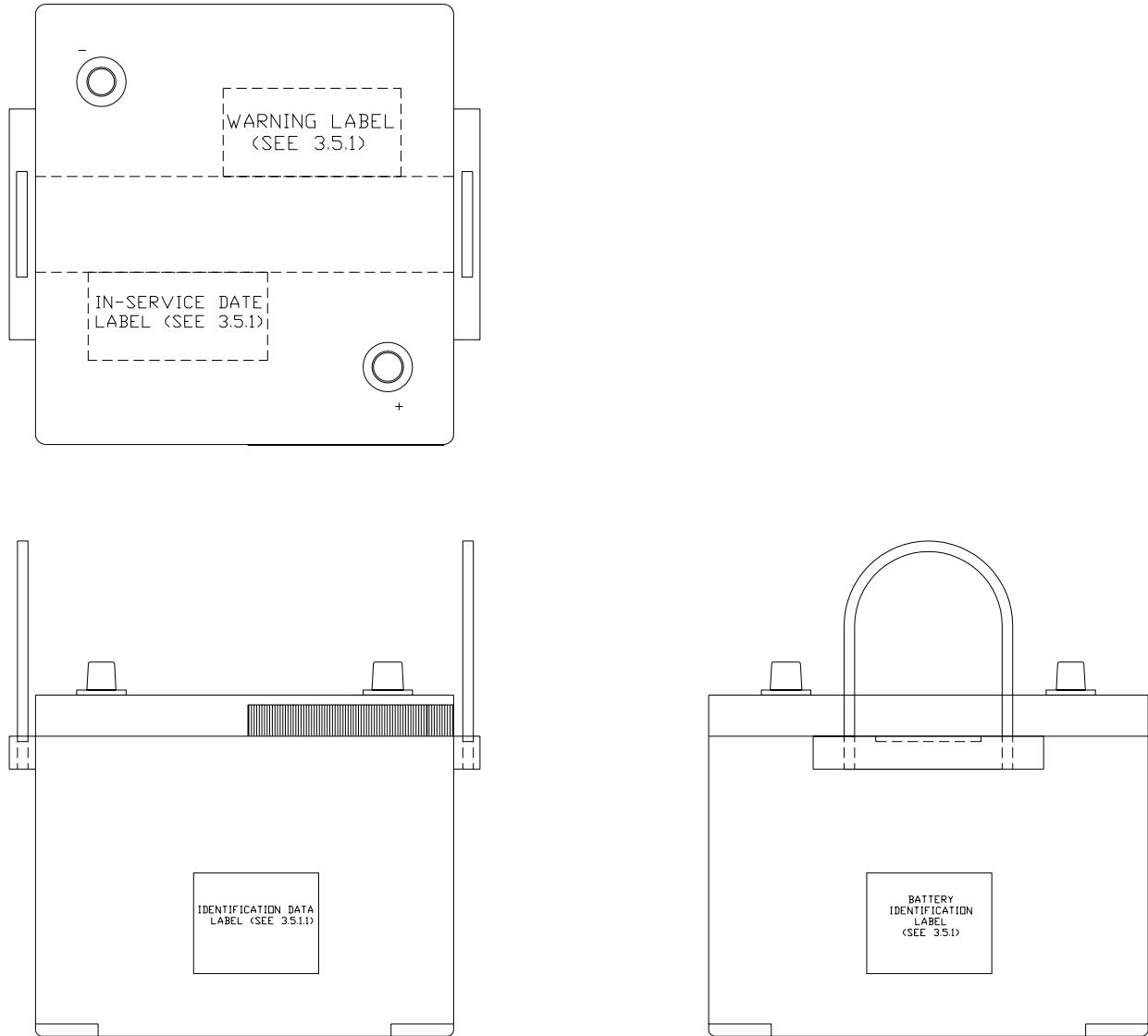

NOTES:

1. For details of construction see **Figures A-2 through A-8**.
2. The use of asterisks (*) throughout the document indicates international agreement (see **note 5 of Figure A-9**).

FIGURE A-2. Battery overview.

MIL-PRF-32143(AT)
 w/AMENDMENT 2
 APPENDIX A

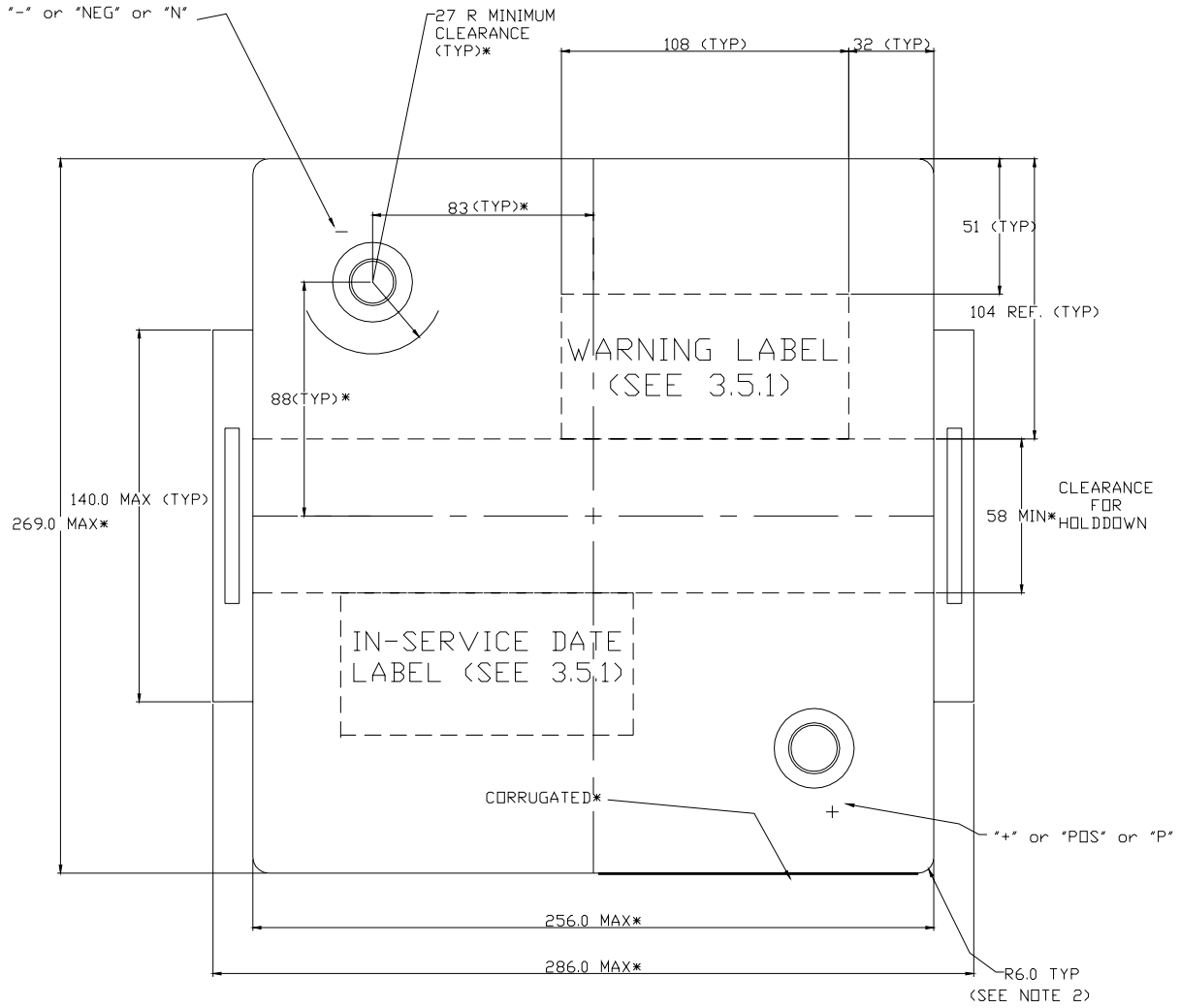

NOTES:

1. Polarity marking may be embossed on the top of tapered post.
2. Chamfer or continuous radius providing equivalent clearance is permitted.

FIGURE A-3. Top view dimensions of battery.

MIL-PRF-32143(AT)
w/AMENDMENT 2
APPENDIX A

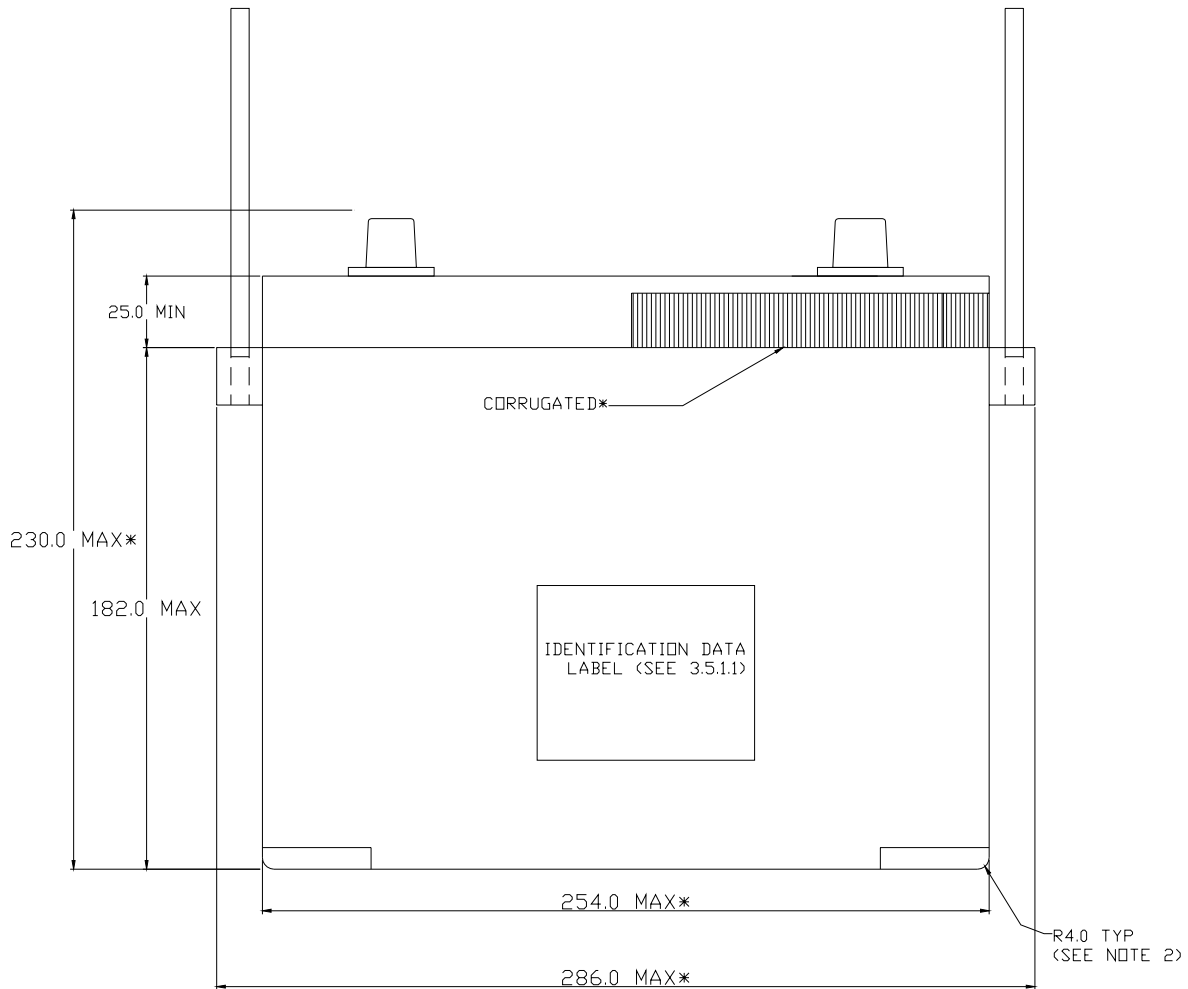

NOTES:

1. Ribbing and detailing on sides of batteries optional.
2. Chamfer or continuous radius providing equivalent clearance is permitted.

FIGURE A-4. Front view dimensions of battery.

MIL-PRF-32143(AT)
w/AMENDMENT 2
APPENDIX A

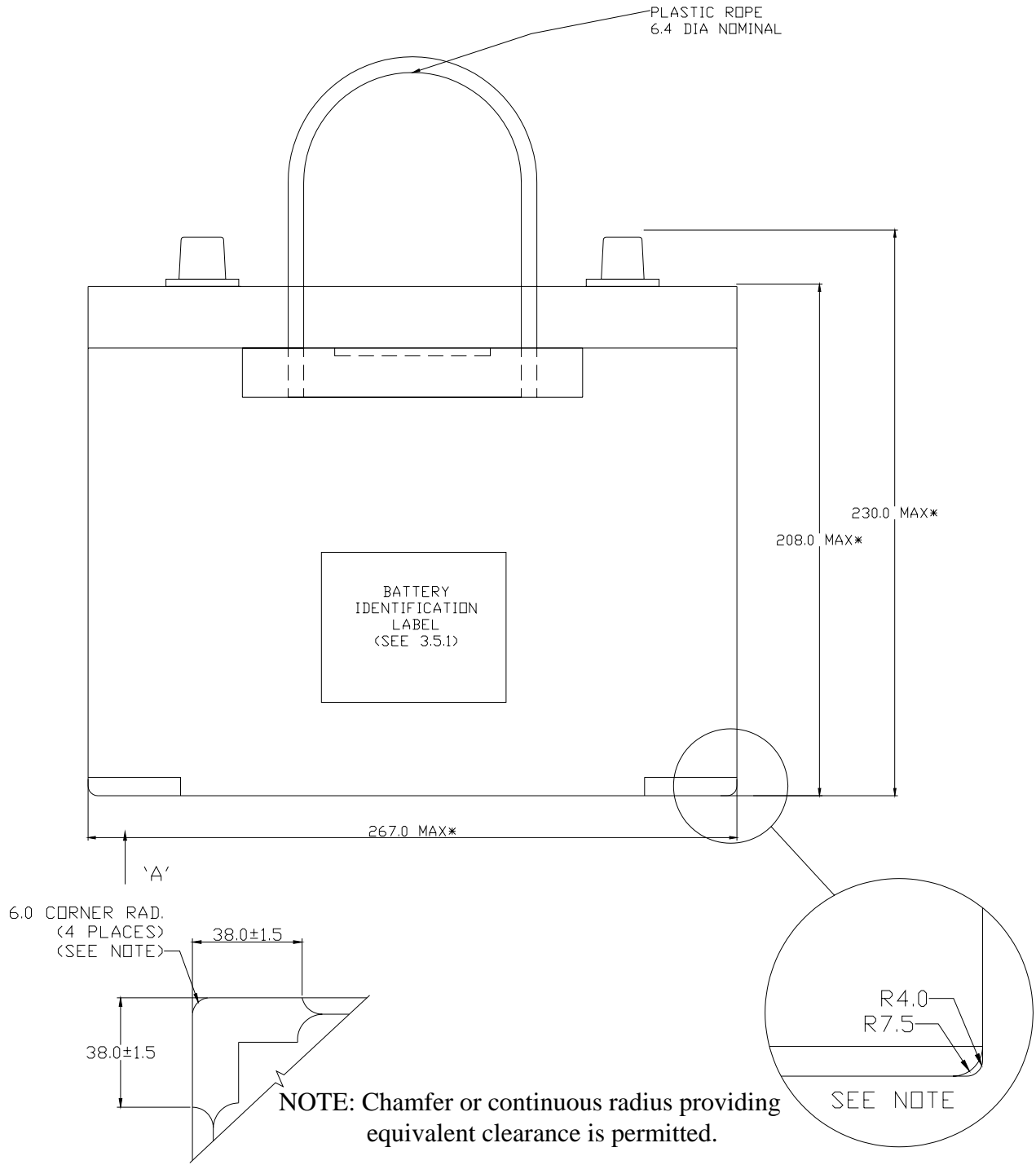

VIEW OF BASE ON ARROW 'A' **FIGURE A-5. Side view dimensions of battery.**

MIL-PRF-32143(AT)
 w/AMENDMENT 2
 APPENDIX A

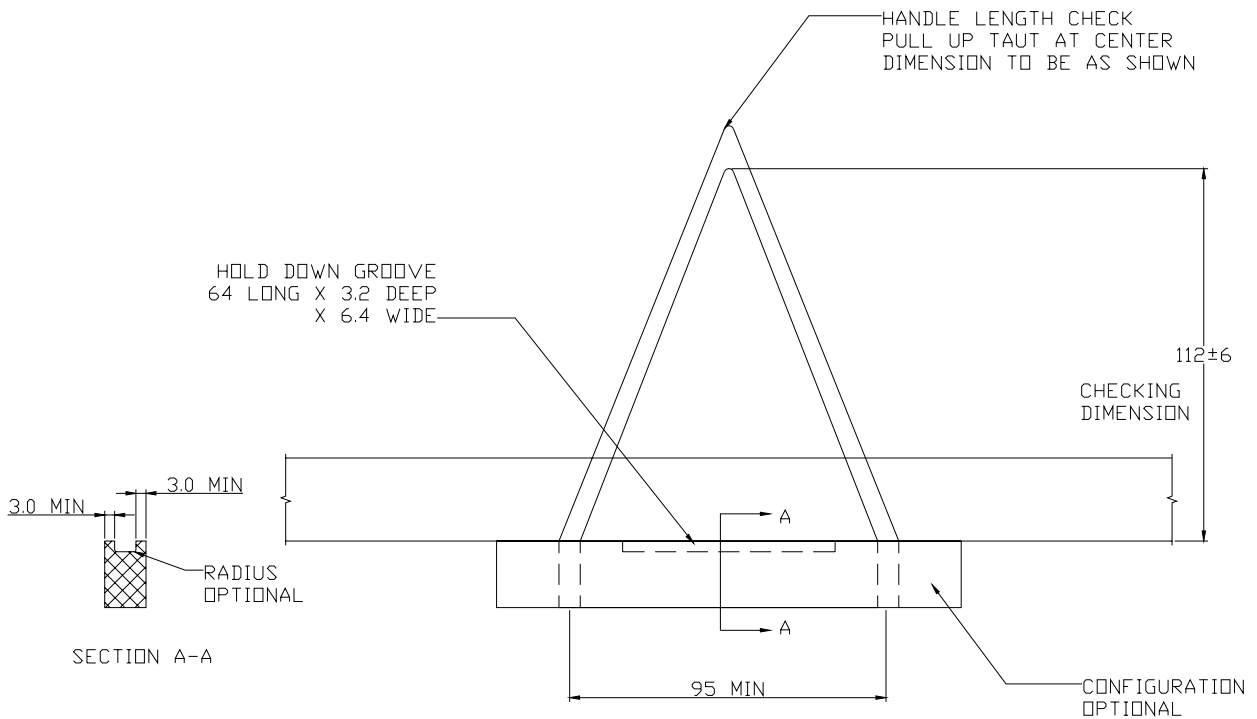
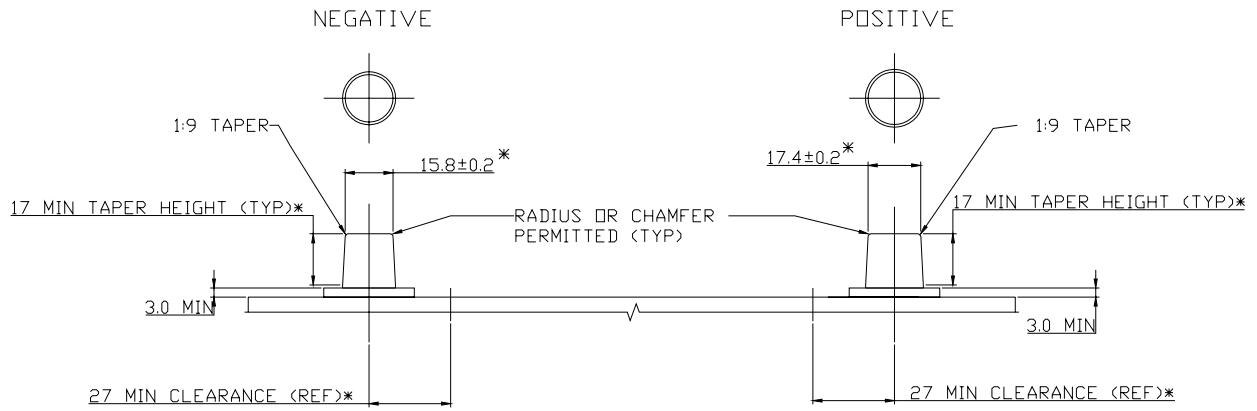

NOTE: Method of rope attachment optional.

FIGURE A-6. Handle and post details.

MIL-PRF-32143(AT)
w/AMENDMENT 2
APPENDIX A

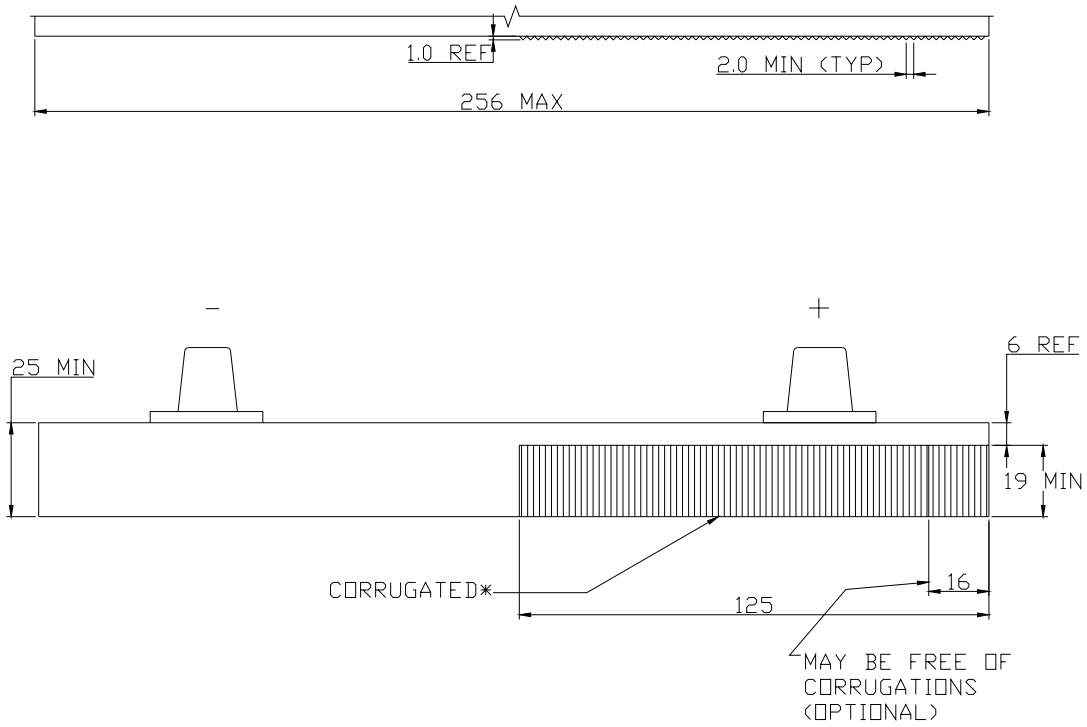

FIGURE A-7. Corrugations by positive post.

MIL-PRF-32143(AT)
 w/AMENDMENT 2
 APPENDIX A

Class	FE
Nominal weight (see note 6)	34kg -2kg/+6.75kg
Nominal voltage	12 volts
Internal resistance	2.0 mΩ ± 0.6 mΩ
Reserve capacity	230 minutes
Discharge rate and time to 7.2 V:	
at -18°C	800 amp 30 sec
at -40°C	400 amp 30 sec
Charging constant potential (see note 4)	14.25 volts

Inspection requirements

Tests	Minimum values
Reserve capacity	230 minutes
Discharge rate and time to 7.2 V:	
at -18°C	800 amp 30 sec
at -40°C	400 amp 30 sec
Life cycle capacity test	360 cycles
Full charge capacity @ 20 hr rate	120 amp hr (6.0 amps)
Retention of charge 40°C:	
Reserve capacity after 90 days	200 minutes
Vibration resistance res. cap	219 minutes

FIGURE A-8. Physical and electrical requirements.

MIL-PRF-32143(AT)
w/AMENDMENT 2
APPENDIX A

NOTES:

1. Dimensions are in millimeters. Unless otherwise specified, tolerances at ± 2.0 mm.
2. This performance specification is not intended to limit construction to features other than shown herein by dimensions, notations, or referenced documents.
3. For design feature purposes, this standard takes precedence over procurement documents referenced herein.
4. For boost charging only – not for vehicle system voltage output.
5. Certain provisions of this appendix which are identified by an asterisk (*) are subject to international standardization agreements NATO STANAG 4015. When amendment, revision, or cancellation of this performance specification is proposed that will modify the international agreements concerned, the preparing activity will take appropriate action through international standardization channels, including departmental standardization offices, to change the agreement or make other appropriate accommodations.
6. 34 kg desired, 40.75 kg maximum.

FIGURE A-9. Appendix, general notes.

MIL-PRF-32143(AT)
w/AMENDMENT 2

Custodian:
Army - AT

Preparing Activity:
Army - AT

(Project 6140-2005-002)

NOTE: The activities listed above were interested in this document as of the date of this document. Since organizations and responsibilities can change, you should verify the currency of the information above using the ASSIST Online database at <http://assist.daps.dla.mil>.