

NASA Technical Memorandum 104060

**NONDIMENSIONAL PARAMETERS AND
EQUATIONS FOR BUCKLING OF
SYMMETRICALLY LAMINATED THIN ELASTIC
SHALLOW SHELLS**

Michael P. Nemeth

March 1991

NASA

National Aeronautics and
Space Administration

Langley Research Center
Hampton, Virginia 23665

**Nondimensional Parameters and Equations for Buckling of
Symmetrically Laminated Thin Elastic Shallow Shells**

**Michael P. Nemeth
NASA Langley Research Center
Hampton, Virginia 23665**

Summary

A method of deriving nondimensional equations and indentifying the fundamental parameters associated with bifurcation buckling of shallow shells subjected to combined loads is presented. More specifically, analysis is presented for symmetrically laminated doubly-curved shells that exhibit both membrane and bending anisotropy. First, equations for nonlinear deformations of thin elastic shallow shells are presented, and buckling equations are derived following the method of adjacent equilibrium states. Next, the procedure and rationale used to obtain useful nondimensional forms of the transverse equilibrium and compatibility equations for buckling are presented. Fundamental parameters are identified that represent the importance of both membrane and bending orthotropy and anisotropy on the results. Moreover, generalizations of the well-known Batdorf Z parameter for symmetrically laminated shells with full anisotropy are presented. Using the nondimensional analysis, generalized forms of Donnell's and Batdorf's equations for shell buckling are also presented, and the shell boundary conditions and approximate solution methods of the boundary-value problem are briefly discussed.

Results obtained from a Bubnov-Galerkin solution of a representative example problem are also presented. The results demonstrate the advantages of formulating the analysis in terms of nondimensional parameters and using these parameters for parametric studies. The results specifically show that

shells with positive Gaussian curvature are much more shear buckling resistant than corresponding flat plates and shells with negative and zero Gaussian curvature. In addition, the results indicate that the importance of bending anisotropy on shear buckling resistance is influenced by shell curvature.

Introduction

Buckling behavior of laminated composite plates and shells has received renewed interest in recent years due to the search for ways to exploit anisotropy in the design of aerospace vehicles. The present study focuses on buckling analysis of symmetrically laminated doubly-curved shallow shells. These shells are candidates for aircraft applications such as wing cover panels, empennage and fuselage skins, engine cowlings, and wing-to-body fairings. In addition, these shells have potential spacecraft applications such as liquid fuel tankage, pressure bulkheads, missile nose cones, and payload modules. Understanding the fundamental parameters that affect the performance of these shell structures, as well as the importance of anisotropy, is a key ingredient of their design, and ultimately their use. Moreover, these parameters can provide valuable information useful in developing scaling laws for structural testing of plates and shells.

Symmetrically laminated shells exhibit anisotropy in the form of material-induced coupling between pure bending and twisting deformations that is commonly exhibited by symmetrically laminated plates undergoing bending deformations. In addition, they exhibit anisotropy in the form of coupling between pure biaxial stretching and membrane shearing. The anisotropy is manifested in shell buckling theory by the presence of odd-combination mixed partial derivatives in the partial differential equations

governing buckling and the natural or force boundary conditions. The presence of these derivative terms prevent simple closed form solutions from being obtained. Studies that assess the importance of anisotropy on buckling behavior of symmetrically laminated plates are presented in references 1 and 2. In reference 1, nondimensionalization of the partial differential equation governing plate buckling is presented and nondimensional parameters are identified that provide physical insight into plate buckling behavior. The results presented in reference 1 suggest the potential for using nondimensional parameters to characterize plate buckling behavior, assess the importance of anisotropy, and aid in their preliminary design. The results presented in the present paper build upon the results presented in reference 1.

A major objective of the present paper is to present nondimensional parameters that will aid in, and simplify, buckling analysis and preliminary design of laminated composite shallow shells. It is a well-known fact that shells with a high degree of curvature are sensitive to small imperfections in their geometry under certain loading conditions, and that this imperfection sensitivity leads to collapse loads often substantially below a predicted bifurcation buckling load [3]. However, there is a class of shell problems for which imperfection sensitivity is minimal under certain loading conditions and the addition of a slight amount of curvature has a positive effect on increasing the buckling resistance of a flat plate [4]. In this case, results obtained from a bifurcation buckling analysis can be used to obtain credible estimates of the collapse load. It is for this class of shallow shells that the nondimensional parameters and equations presented in the present paper have been derived. A significant example of a nondimensional parameter that has seen wide use in the buckling analysis and

design of isotropic cylindrical shells is the well-known Batdorf Z or curvature parameter [5,6].

Nondimensional parameters can play a key role in the preliminary design of aerospace vehicles. An important consideration is that, in the initial preliminary design phase, a structural designer is usually under severe time constraints and often prefers to have information available in a handy chart form. Nondimensional parameters permit fundamental results to be presented as a series of curves, on one or more plots, that cover the complete range of shell dimensions, loading combinations, boundary conditions, and material properties. In addition, the curves also furnish the designer with an overall indication of the sensitivity of the structural response to changes in geometry, loading conditions, boundary conditions, or material properties. Often in preparing design charts of this nature, a special purpose analysis is preferred over a general purpose analysis due to the cost and effort involved in generating results encompassing a wide range of design parameters. Examples of design charts for buckling and postbuckling of orthotropic plates that use nondimensional parameters are presented in references 7 and 8. Another very useful benefit of nondimensional parameters is that they can be used to greatly simplify the equations and results when performing analysis and to provide insight into the order and importance of various terms appearing in the equations.

Two major objectives of the present paper are to present a method of deriving nondimensional equations for doubly-curved shallow shells subjected to combined loads, and to identify the fundamental parameters associated with bifurcation buckling of these shells. The paper begins with a presentation of the equations for nonlinear deformations of symmetrically laminated elastic shallow thin shells. Next, the equations for buckling are

presented using the method of adjacent equilibrium states, and are cast into a form suitable for nondimensionalization. The paper then indicates the steps required, and the rationale used, to obtain nondimensional forms of the transverse equilibrium and compatibility equations for buckling. Fundamental parameters are then identified that can be used to represent the importance of membrane and bending orthotropy and anisotropy on shell behavior. Parameters are also presented that are generalizations of the Batdorf Z parameter for symmetrically laminated shells with full anisotropy.

After obtaining the nondimensional buckling equations and identifying the nondimensional parameters, generalized forms of Donnell's and Batdorf's equations for shell buckling are presented. These generalized equations contain the effects of both laminated material properties of the shell as well as double curvature. Finally, a brief discussion of shell boundary conditions and approximate solution methods for the shell buckling problem is presented.

The analysis presented in the present paper was inspired by the work presented in reference 8. For this reason, and for many useful discussions, the author would like to dedicate this paper to the late Dr. Manuel Stein of NASA Langley Research Center.

Equations for Nonlinear Deformations

The basic equations for doubly-curved shallow shells of general shape and uniform thickness t are presented in this section in terms of the orthogonal lines-of-curvature curvilinear coordinates (ξ_1, ξ_2, ζ) shown in figure 1. The equations presented consist of the strain-displacement relations, nonlinear equilibrium equations, compatibility equations, and constitutive equations for symmetrically laminated shells.

Strain-Displacement Relations

The nonlinear strain-displacement relations used herein to describe the deformation of a shallow shell of general shape are the relations of Donnell-Mushtari-Vlasov classical thin-shell theory. These relations are well known (for example see reference 6, pp. 190-197), and are given by

$$\begin{aligned}\epsilon_1(\xi_1, \xi_2, \zeta) &= \epsilon_1^0(\xi_1, \xi_2) + \zeta \kappa_1^0(\xi_1, \xi_2) \\ \epsilon_2(\xi_1, \xi_2, \zeta) &= \epsilon_2^0(\xi_1, \xi_2) + \zeta \kappa_2^0(\xi_1, \xi_2) \\ \epsilon_3(\xi_1, \xi_2, \zeta) &= 0\end{aligned}\tag{1}$$

$$\begin{aligned}\gamma_{12}(\xi_1, \xi_2, \zeta) &= \gamma_{12}^0(\xi_1, \xi_2) + \zeta \kappa_{12}^0(\xi_1, \xi_2) \\ \gamma_{13}(\xi_1, \xi_2, \zeta) &= \gamma_{13}^0(\xi_1, \xi_2) \\ \gamma_{23}(\xi_1, \xi_2, \zeta) &= \gamma_{23}^0(\xi_1, \xi_2)\end{aligned}$$

in which

$$\epsilon_1^0 = \frac{1}{A_1} \frac{\partial u_1}{\partial \xi_1} + \frac{u_2}{A_1 A_2} \frac{\partial A_1}{\partial \xi_2} + \frac{w}{R_1} + \frac{1}{2} \left(\frac{1}{A_1} \frac{\partial w}{\partial \xi_1} \right)^2\tag{2}$$

$$\epsilon_2^0 = \frac{1}{A_2} \frac{\partial u_2}{\partial \xi_2} + \frac{u_1}{A_1 A_2} \frac{\partial A_2}{\partial \xi_1} + \frac{w}{R_2} + \frac{1}{2} \left(\frac{1}{A_2} \frac{\partial w}{\partial \xi_2} \right)^2\tag{3}$$

$$\gamma_{12}^0 = \frac{1}{A_2} \frac{\partial u_1}{\partial \xi_2} - \frac{u_2}{A_1 A_2} \frac{\partial A_2}{\partial \xi_1} + \frac{1}{A_1} \frac{\partial u_2}{\partial \xi_1} - \frac{u_1}{A_1 A_2} \frac{\partial A_1}{\partial \xi_2} + \frac{1}{A_1 A_2} \frac{\partial w}{\partial \xi_1} \frac{\partial w}{\partial \xi_2}\tag{4}$$

$$\kappa_1^0 = \frac{1}{A_1} \frac{\partial \beta_1}{\partial \xi_1} + \frac{\beta_2}{A_1 A_2} \frac{\partial A_1}{\partial \xi_2}\tag{5}$$

$$\kappa_2^0 = \frac{1}{A_2} \frac{\partial \beta_2}{\partial \xi_2} + \frac{\beta_1}{A_1 A_2} \frac{\partial A_2}{\partial \xi_1}\tag{6}$$

$$\kappa_{12}^0 = \frac{1}{A_2} \frac{\partial \beta_1}{\partial \xi_2} - \frac{\beta_2}{A_1 A_2} \frac{\partial A_2}{\partial \xi_1} + \frac{1}{A_1} \frac{\partial \beta_2}{\partial \xi_1} - \frac{\beta_1}{A_1 A_2} \frac{\partial A_1}{\partial \xi_2} \quad (7)$$

$$\gamma_{13}^0 = \beta_1 + \frac{1}{A_1} \frac{\partial w}{\partial \xi_1} \quad (8)$$

$$\gamma_{23}^0 = \beta_2 + \frac{1}{A_2} \frac{\partial w}{\partial \xi_2} \quad (9)$$

The symbols u_1 and u_2 are the displacements of the shell reference surface (in the tangent plane) in the ξ_1 and ξ_2 directions, respectively, and the symbol w is the displacement along the direction normal to the shell surface. The coordinate ζ corresponds to a distance along an axis normal to the shell surface, at a given point, as shown in figure 1. The terms R_1 and R_2 represent the principal radii of curvature of the reference surface along the ξ_1 and ξ_2 coordinate directions, respectively, and the symbols A_1 and A_2 are the coefficients of the first fundamental form of the surface given by

$$(dS)^2 = (A_1 d\xi_1)^2 + (A_2 d\xi_2)^2 \quad (10)$$

where dS is the differential arc-length between to neighboring points on the surface. The terms ϵ_1^0 , ϵ_2^0 , and γ_{12}^0 are the membrane strains, and the terms κ_1^0 , κ_2^0 , and κ_{12}^0 , when multiplied by ζ are the strains associated with changes in curvature of the shell reference surface. The terms γ_{13}^0 and γ_{23}^0 are the transverse shearing strains and are assumed to be zero-valued in accordance with the assumptions of classical first-approximation thin-shell theory. Enforcing this condition yields expressions for the surface rotations in term of the normal deflection w ; i.e.,

$$\beta_1 = - \frac{1}{A_1} \frac{\partial w}{\partial \xi_1} \quad (11)$$

$$\beta_2 = - \frac{1}{A_2} \frac{\partial w}{\partial \xi_2} \quad (12)$$

Nonlinear Equilibrium Equations

The nonlinear equilibrium equations of Donnell-Mushtari-Vlasov shallow shell theory are obtained by enforcing equilibrium of a differential shell element in its deformed configuration. The equations resulting from this process are given as follows. The equation corresponding to the summation of forces in the ξ_1 direction is given by

$$\frac{\partial}{\partial \xi_1} (N_1 A_2) + \frac{\partial}{\partial \xi_2} (N_{12} A_1) - N_2 \frac{\partial A_2}{\partial \xi_1} + N_{12} \frac{\partial A_1}{\partial \xi_2} + A_1 A_2 q_1 = 0 \quad (13)$$

where N_1 , N_2 , and N_{12} are the membrane stress resultants and q_1 is an applied membrane surface traction. Similarly, the equation corresponding to the summation of forces in the ξ_2 direction is given by

$$\frac{\partial}{\partial \xi_1} (N_{12} A_2) + \frac{\partial}{\partial \xi_2} (N_2 A_1) - N_1 \frac{\partial A_1}{\partial \xi_2} + N_{12} \frac{\partial A_2}{\partial \xi_1} + A_1 A_2 q_2 = 0 \quad (14)$$

where q_2 is also an applied membrane surface traction. The equation corresponding to the summation of forces in the ζ direction is given by

$$\frac{\partial}{\partial \xi_1} (Q_1 A_2) + \frac{\partial}{\partial \xi_2} (Q_2 A_1) + A_1 A_2 \left[q_3 - \frac{N_1}{R_1} - \frac{N_2}{R_2} \right] + P_m = 0 \quad (15a)$$

where P_m denotes the contribution of the membrane forces to the transverse (normal to the surface) equilibrium that is given by

$$P_m = \frac{\partial}{\partial \xi_1} \left[N_1 A_2 \left(\frac{1}{A_1} \frac{\partial w}{\partial \xi_1} \right) + N_{12} A_2 \left(\frac{1}{A_2} \frac{\partial w}{\partial \xi_2} \right) \right]$$

$$+ \frac{\partial}{\partial \xi_2} [N_{12} A_1 (\frac{1}{A_1} \frac{\partial w}{\partial \xi_1}) + N_2 A_1 (\frac{1}{A_2} \frac{\partial w}{\partial \xi_2})] \quad (15b)$$

The symbols Q_1 and Q_2 denote the transverse shearing stress resultants. The equation corresponding to the summation of moments about the ξ_1 -axis is given by

$$\frac{\partial}{\partial \xi_1} (M_1 A_2) + \frac{\partial}{\partial \xi_2} (M_{12} A_1) + M_{12} \frac{\partial A_1}{\partial \xi_2} - M_2 \frac{\partial A_2}{\partial \xi_1} - A_1 A_2 Q_1 = 0 \quad (16)$$

where M_1 , M_2 , and M_{12} are the bending stress resultants. Similarly, the equation corresponding to the summation of moments about the ξ_2 -axis is given by

$$\frac{\partial}{\partial \xi_1} (M_{12} A_2) + \frac{\partial}{\partial \xi_2} (M_2 A_1) + M_{12} \frac{\partial A_2}{\partial \xi_1} - M_1 \frac{\partial A_1}{\partial \xi_2} - A_1 A_2 Q_2 = 0 \quad (17)$$

A more convenient form of the nonlinear equilibrium equations, for the purpose of defining nondimensional parameters, is obtained by requiring the curvilinear coordinates ξ_1 and ξ_2 to be surface coordinates with units of length. A new set of curvilinear coordinates s_1 and s_2 are introduced such that

$$(dS)^2 = (ds_1)^2 + (ds_2)^2 \quad (18)$$

For this set of coordinates, $A_1 = 1$ and $A_2 = 1$. The nonlinear equilibrium equations simplify to

$$\frac{\partial N_1}{\partial s_1} + \frac{\partial N_{12}}{\partial s_2} + q_1 = 0 \quad (19a)$$

$$\frac{\partial N_{12}}{\partial s_1} + \frac{\partial N_2}{\partial s_2} + q_2 = 0 \quad (19b)$$

$$\frac{\partial Q_1}{\partial s_1} + \frac{\partial Q_2}{\partial s_2} + q_3 - \frac{N_1}{R_1} - \frac{N_2}{R_2} + P_m = 0 \quad (19c)$$

where

$$P_m = \frac{\partial}{\partial \xi_1} \left[N_1 \frac{\partial w}{\partial s_1} + N_{12} \frac{\partial w}{\partial s_2} \right] + \frac{\partial}{\partial s_2} \left[N_{12} \frac{\partial w}{\partial s_1} + N_2 \frac{\partial w}{\partial s_2} \right] \quad (19d)$$

$$\frac{\partial M_1}{\partial s_1} + \frac{\partial M_{12}}{\partial s_2} - Q_1 = 0 \quad (19e)$$

$$\frac{\partial M_2}{\partial s_2} + \frac{\partial M_{12}}{\partial s_1} - Q_2 = 0 \quad (19f)$$

A similar set of equations derived for postbuckling analysis of isotropic shallow shells subjected to thermal loads is presented in reference 9.

The equilibrium equations given in equation (19) are reduced to a set of three equilibrium equations as follows. First, the expression for P_m given by equation (19d) is rearranged, by differentiating, to give

$$P_m = \left[\frac{\partial N_1}{\partial s_1} + \frac{\partial N_{12}}{\partial s_2} \right] \frac{\partial w}{\partial s_1} + \left[\frac{\partial N_{12}}{\partial s_1} + \frac{\partial N_2}{\partial s_2} \right] \frac{\partial w}{\partial s_2} + N_1 \frac{\partial^2 w}{\partial s_1^2} + N_2 \frac{\partial^2 w}{\partial s_2^2} + 2N_{12} \frac{\partial^2 w}{\partial s_1 \partial s_2} \quad (20)$$

Substituting equations (19a) and (19b) into equation (20) gives

$$P_m = -q_1 \frac{\partial w}{\partial s_1} - q_2 \frac{\partial w}{\partial s_2} + N_1 \frac{\partial^2 w}{\partial s_1^2} + N_2 \frac{\partial^2 w}{\partial s_2^2} + 2N_{12} \frac{\partial^2 w}{\partial s_1 \partial s_2} \quad (21)$$

Next, eliminating the transverse shear stress resultants from equation (19c) using equations (19e) and (19f) gives

$$\frac{\partial^2 M_1}{\partial s_1^2} + 2 \frac{\partial^2 M_{12}}{\partial s_1 \partial s_2} + \frac{\partial^2 M_2}{\partial s_2^2} - \frac{N_1}{R_1} - \frac{N_2}{R_2} + q_3 - q_1 \frac{\partial w}{\partial s_1} - q_2 \frac{\partial w}{\partial s_2}$$

$$+ N_1 \frac{\partial^2 w}{\partial s_1^2} + N_2 \frac{\partial^2 w}{\partial s_2^2} + 2N_{12} \frac{\partial^2 w}{\partial s_1 \partial s_2} = 0 \quad (22)$$

Equations (19a), (19b), and (22) are the nonlinear equilibrium equations used in this paper to obtain the equations for buckling of shallow shells.

Compatibility Equation

The compatibility equation for the nonlinear boundary-value problem is obtained by eliminating u_1 and u_2 from equations (2), (3), and (4). It is convenient, for the purpose of the present study, to express equations (2) through (4) in term of the length coordinates; i.e.,

$$\epsilon_1^0 = \frac{\partial u_1}{\partial s_1} + \frac{w}{R_1} + \frac{1}{2} \left(\frac{\partial w}{\partial s_1} \right)^2 \quad (23)$$

$$\epsilon_2^0 = \frac{\partial u_2}{\partial s_2} + \frac{w}{R_2} + \frac{1}{2} \left(\frac{\partial w}{\partial s_2} \right)^2 \quad (24)$$

$$\gamma_{12}^0 = \frac{\partial u_1}{\partial s_2} + \frac{\partial u_2}{\partial s_1} + \frac{\partial w}{\partial s_1} \frac{\partial w}{\partial s_2} \quad (25)$$

Eliminating u_1 and u_2 yields

$$\frac{\partial^2 \epsilon_1^0}{\partial s_2^2} + \frac{\partial^2 \epsilon_2^0}{\partial s_1^2} - \frac{\partial^2 \gamma_{12}^0}{\partial s_1 \partial s_2} = \left(\frac{\partial^2 w}{\partial s_1 \partial s_2} \right)^2 - \frac{\partial^2 w}{\partial s_1} \frac{\partial^2 w}{\partial s_2} + \frac{\partial^2}{\partial s_1} \left(\frac{w}{R_2} \right) + \frac{\partial^2}{\partial s_2} \left(\frac{w}{R_1} \right) \quad (26)$$

For shallow shells, for which the curvatures are mildly varying, the following approximation is used to simplify the compatibility equation; i.e.,

$$\frac{\partial^2}{\partial s_1} \left(\frac{w}{R_2} \right) \approx \frac{1}{R_2} \frac{\partial^2 w}{\partial s_1^2} \quad (27a)$$

$$\frac{\partial^2}{\partial s_2^2} \left(\frac{w}{R_1} \right) \approx \frac{1}{R_1} \frac{\partial^2 w}{\partial s_2^2} \quad (27b)$$

Using this approximation, the compatibility equation becomes

$$\frac{\partial^2 \epsilon_1^0}{\partial s_2^2} + \frac{\partial^2 \epsilon_2^0}{\partial s_1^2} - \frac{\partial^2 \gamma_{12}^0}{\partial s_1 \partial s_2} = \left(\frac{\partial^2 w}{\partial s_1 \partial s_2} \right)^2 - \frac{\partial^2 w}{\partial s_1^2} \frac{\partial^2 w}{\partial s_2^2} + \frac{1}{R_2} \frac{\partial^2 w}{\partial s_1^2} + \frac{1}{R_1} \frac{\partial^2 w}{\partial s_2^2} \quad (28)$$

Constitutive Equations

The shells considered in this paper are symmetrically laminated and exhibit both anisotropic membrane and bending behavior. The corresponding constitutive equations are given by

$$N_1 = A_{11} \epsilon_1^0 + A_{12} \epsilon_2^0 + A_{16} \gamma_{12}^0 \quad (29a)$$

$$N_2 = A_{12} \epsilon_1^0 + A_{22} \epsilon_2^0 + A_{26} \gamma_{12}^0 \quad (29b)$$

$$N_{12} = A_{16} \epsilon_1^0 + A_{26} \epsilon_2^0 + A_{66} \gamma_{12}^0 \quad (29c)$$

$$M_1 = -D_{11} \frac{\partial^2 w}{\partial s_1^2} - D_{12} \frac{\partial^2 w}{\partial s_2^2} - 2D_{16} \frac{\partial^2 w}{\partial s_1 \partial s_2} \quad (30a)$$

$$M_2 = -D_{12} \frac{\partial^2 w}{\partial s_1^2} - D_{22} \frac{\partial^2 w}{\partial s_2^2} - 2D_{26} \frac{\partial^2 w}{\partial s_1 \partial s_2} \quad (30b)$$

$$M_{12} = -D_{16} \frac{\partial^2 w}{\partial s_1^2} - D_{26} \frac{\partial^2 w}{\partial s_2^2} - 2D_{66} \frac{\partial^2 w}{\partial s_1 \partial s_2} \quad (30c)$$

where A_{11} , A_{12} , A_{22} , and A_{66} are the orthotropic membrane stiffnesses;

A_{16} and A_{26} are the anisotropic membrane stiffnesses; D_{11} , D_{12} , D_{22} , and D_{66}

are the orthotropic bending stiffnesses; and D_{16} and D_{26} are the anisotropic

bending stiffnesses of classical laminated thin-shell theory (for example see reference 10).

Buckling Equations

The equations governing buckling are derived using the method of adjacent equilibrium described in reference 6 (see pp. 201-202). Prior to buckling, the shell is assumed to be in a primary equilibrium state given by the displacement field (u_1^P, u_2^P, w^P) . Near the point of buckling, there is assumed to exist an adjacent equilibrium state $(\delta u_1, \delta u_2, \delta w)$ sufficiently close to the primary equilibrium state such that δu_1 , δu_2 , and δw are infinitesimal quantities. Moreover, prebuckling displacements normal to the shell reference surface are presumed to be negligible; i.e., $w^P = 0$. Using this method, the linearized bifurcation buckling equations are obtained by substituting

$$u_1 \rightarrow u_1^P + \delta u_1 \quad (31a)$$

$$u_2 \rightarrow u_2^P + \delta u_2 \quad (31b)$$

$$w \rightarrow 0 + \delta w \quad (31c)$$

into the basic equations of the nonlinear boundary-value problem given previously. Associated with the substitutions defined by equations (31) are variations in the strains and changes in curvature. In addition, increments in strains and changes in curvature produce increments in the stress resultants via the constitutive equations. The relationships for the strains and changes in curvature are given by

$$\epsilon_1^0 \rightarrow \epsilon_1^P + \delta \epsilon_1 \quad (32a)$$

$$\epsilon_2^0 \rightarrow \epsilon_2^p + \delta\epsilon_2 \quad (32b)$$

$$\gamma_{12}^0 \rightarrow \gamma_{12}^p + \delta\gamma_{12} \quad (32c)$$

$$\kappa_1^0 \rightarrow 0 + \delta\kappa_1 \quad (32d)$$

$$\kappa_2^0 \rightarrow 0 + \delta\kappa_2 \quad (32e)$$

$$\kappa_{12}^0 \rightarrow 0 + \delta\kappa_{12} \quad (32f)$$

where

$$\epsilon_1^p = \frac{\partial u_1}{\partial s_1} \quad (33a)$$

$$\epsilon_2^p = \frac{\partial u_2}{\partial s_2} \quad (33b)$$

$$\gamma_{12}^p = \frac{\partial u_1}{\partial s_2} + \frac{\partial u_2}{\partial s_1} \quad (33c)$$

$$\delta\epsilon_1 = \frac{\partial \delta u_1}{\partial s_1} + \frac{\delta w}{R_1} \quad (33d)$$

$$\delta\epsilon_2 = \frac{\partial \delta u_2}{\partial s_2} + \frac{\delta w}{R_2} \quad (33e)$$

$$\delta\gamma_{12} = \frac{\partial \delta u_1}{\partial s_2} + \frac{\partial \delta u_2}{\partial s_1} \quad (33f)$$

$$\delta\kappa_1^0 = -\frac{\partial^2 \delta w}{\partial s_1^2} \quad (33g)$$

$$\delta\kappa_2^0 = -\frac{\partial^2 \delta w}{\partial s_2^2} \quad (33h)$$

$$\delta\kappa_{12}^0 = -2 \frac{\partial^2 \delta w}{\partial s_1 \partial s_2} \quad (33k)$$

and where the superscript p denotes the primary equilibrium state. The relationships for the stress resultants are given by

$$N_1 \rightarrow N_1^p + \delta N_1 \quad (34a)$$

$$N_2 \rightarrow N_2^p + \delta N_2 \quad (34b)$$

$$N_{12} \rightarrow N_{12}^p + \delta N_{12} \quad (34c)$$

$$M_1 \rightarrow M_1^p + \delta M_1 \quad (34d)$$

$$M_2 \rightarrow M_2^p + \delta M_2 \quad (34e)$$

$$M_{12} \rightarrow M_{12}^p + \delta M_{12} \quad (34f)$$

and result from substituting equations (32) into the constitutive equations (29) and (30). The superscript p again denotes the primary equilibrium state. In equations (32) and (33) terms of quadratic degree and higher in δu_1 , δu_2 , and δw have been omitted in accordance with the assumption that the variations are infinitesimal in size. The specific form of the constitutive equations are given by

$$\delta N_1 = A_{11} \left(\frac{\partial \delta u_1}{\partial s_1} + \frac{\delta w}{R_1} \right) + A_{12} \left(\frac{\partial \delta u_2}{\partial s_2} + \frac{\delta w}{R_2} \right) + A_{16} \left(\frac{\partial \delta u_1}{\partial s_2} + \frac{\partial \delta u_2}{\partial s_1} \right) \quad (35a)$$

$$\delta N_2 = A_{12} \left(\frac{\partial \delta u_1}{\partial s_1} + \frac{\delta w}{R_1} \right) + A_{22} \left(\frac{\partial \delta u_2}{\partial s_2} + \frac{\delta w}{R_2} \right) + A_{26} \left(\frac{\partial \delta u_1}{\partial s_2} + \frac{\partial \delta u_2}{\partial s_1} \right) \quad (35b)$$

$$\delta N_{12} = A_{16} \left(\frac{\partial \delta u_1}{\partial s_1} + \frac{\delta w}{R_1} \right) + A_{26} \left(\frac{\partial \delta u_2}{\partial s_2} + \frac{\delta w}{R_2} \right) + A_{66} \left(\frac{\partial \delta u_1}{\partial s_2} + \frac{\partial \delta u_2}{\partial s_1} \right) \quad (35c)$$

$$\delta M_1 = -D_{11} \frac{\partial^2 \delta w}{\partial s_1^2} - D_{12} \frac{\partial^2 \delta w}{\partial s_2^2} - 2D_{16} \frac{\partial^2 \delta w}{\partial s_1 \partial s_2} \quad (35d)$$

$$\delta M_2 = -D_{12} \frac{\partial^2 \delta w}{\partial s_1^2} - D_{22} \frac{\partial^2 \delta w}{\partial s_2^2} - 2D_{26} \frac{\partial^2 \delta w}{\partial s_1 \partial s_2} \quad (35e)$$

$$\delta M_{12} = -D_{16} \frac{\partial^2 \delta w}{\partial s_1^2} - D_{26} \frac{\partial^2 \delta w}{\partial s_2^2} - 2D_{66} \frac{\partial^2 \delta w}{\partial s_1 \partial s_2} \quad (35f)$$

The form of the buckling equations used herein are obtained by substituting equations (31) through (34) into equations (19a), (19b), (22), and (28). Neglecting terms greater than linear in the displacement, strain, changes of curvature, and stress resultant increments yields the following equations of the adjacent equilibrium state (buckling equations)

$$\frac{\partial \delta N_1}{\partial s_1} + \frac{\partial \delta N_{12}}{\partial s_2} = 0 \quad (36a)$$

$$\frac{\partial \delta N_{12}}{\partial s_1} + \frac{\partial \delta N_2}{\partial s_2} = 0 \quad (36b)$$

$$\begin{aligned} \frac{\partial^2 \delta M_1}{\partial s_1^2} + 2 \frac{\partial^2 \delta M_{12}}{\partial s_1 \partial s_2} + \frac{\partial^2 \delta M_2}{\partial s_2^2} - \frac{\delta N_1}{R_1} - \frac{\delta N_2}{R_2} - q_1 \frac{\partial \delta w}{\partial s_1} - q_2 \frac{\partial \delta w}{\partial s_2} \\ + N_1 \frac{\partial^2 \delta w}{\partial s_1^2} + N_2 \frac{\partial^2 \delta w}{\partial s_2^2} + 2N_{12} \frac{\partial^2 \delta w}{\partial s_1 \partial s_2} = 0 \end{aligned} \quad (36c)$$

$$\frac{\partial^2 \delta \epsilon_1}{\partial s_2^2} + \frac{\partial^2 \delta \epsilon_2}{\partial s_1^2} - \frac{\partial^2 \delta \gamma_{12}}{\partial s_1 \partial s_2} = \frac{1}{R_2} \frac{\partial^2 \delta w}{\partial s_1^2} + \frac{1}{R_1} \frac{\partial^2 \delta w}{\partial s_2^2} \quad (36d)$$

where the superscript p on the prebuckling stress resultants has been dropped for simplicity. An additional operation used, but not explicitly shown, to obtain the buckling equations given above is the enforcement of the requirement that the primary equilibrium state satisfies the equilibrium equations and compatibility equation of the nonlinear boundary-value problem.

Nondimensionalization of the Buckling Equations and Parameters

One objective of this paper is to determine the nondimensional parameters governing the buckling behavior of shallow thin elastic shells. This objective is accomplished following the procedure presented by Batdorf in references 11 through 13 for isotropic curved plates, by Stein in reference 8 for flat laminated orthotropic plates, and by the author in reference 1 for flat symmetrically laminated plates. The rationale used in this paper for deriving the nondimensional equations and selecting the nondimensional parameters follows, to a great extent, the work presented by Stein [8]. This rationale is to make the the field variables and their derivatives of order one, minimize the number of independent parameters required to characterize the behavior, and to avoid introducing preferential direction into the nondimensional equations.

The first step in the nondimensionalization procedure is to formulate the boundary-value problem in its simplest form which corresponds to two coupled homogeneous linear partial differential equations. This task is accomplished by introducing a stress resultant function $\delta\Phi$ defined by

$$\delta N_1 = \frac{\partial^2 \delta\Phi}{\partial s_2^2} \quad (37a)$$

$$\delta N_2 = \frac{\partial^2 \delta\Phi}{\partial s_1^2} \quad (37b)$$

$$\delta N_{12} = - \frac{\partial^2 \delta\Phi}{\partial s_1 \partial s_2} \quad (37c)$$

This stress resultant function (or simply stress function) satisfies equations (36a) and (36b) identically. Upon eliminating these two equations from the boundary-value problem, the equation guaranteeing compatibility of

the buckling strains must be satisfied. This buckling compatibility equation is given by equation (36d). To get the buckling compatibility equation into a solvable form, the inverted form of the constitutive equations are used to express the buckling strains in terms of the stress function; i.e.,

$$\delta \epsilon_1 = a_{11} \frac{\partial^2 \delta \Phi}{\partial s_2^2} + a_{12} \frac{\partial^2 \delta \Phi}{\partial s_1^2} - a_{16} \frac{\partial^2 \delta \Phi}{\partial s_1 \partial s_2} \quad (38a)$$

$$\delta \epsilon_2 = a_{12} \frac{\partial^2 \delta \Phi}{\partial s_2^2} + a_{22} \frac{\partial^2 \delta \Phi}{\partial s_1^2} - a_{26} \frac{\partial^2 \delta \Phi}{\partial s_1 \partial s_2} \quad (38b)$$

$$\delta \gamma_{12} = a_{16} \frac{\partial^2 \delta \Phi}{\partial s_2^2} + a_{26} \frac{\partial^2 \delta \Phi}{\partial s_1^2} - a_{66} \frac{\partial^2 \delta \Phi}{\partial s_1 \partial s_2} \quad (38c)$$

where equations (37) have been substituted into the usual constitutive equations involving the membrane stress resultants, and where a_{11} , a_{12} , a_{22} , a_{16} , a_{26} , and a_{66} denote the coefficients of the inverted form of the membrane constitutive equations. Substituting equations (38) into the buckling compatibility equation (36d) and simplifying gives

$$a_{22} \frac{\partial^4 \delta \Phi}{\partial s_1^4} - 2a_{26} \frac{\partial^4 \delta \Phi}{\partial s_1^3 \partial s_2} + (2a_{12} + a_{66}) \frac{\partial^4 \delta \Phi}{\partial s_1^2 \partial s_2^2} - 2a_{16} \frac{\partial^4 \delta \Phi}{\partial s_1 \partial s_2^3} + a_{11} \frac{\partial^4 \delta \Phi}{\partial s_2^4} = \frac{1}{R_2} \frac{\partial^2 \delta w}{\partial s_1^2} + \frac{1}{R_1} \frac{\partial^2 \delta w}{\partial s_2^2} \quad (39)$$

Following the analysis presented in reference 8, the following nondimensional coordinates are used

$$z_1 = s_1/L_1 \text{ and } z_2 = s_2/L_2 \quad (40)$$

where L_1 and L_2 are characteristic dimensions of the shell shown in figure

1. Substituting these nondimensional coordinates into equation (39) and

multiplying through by $L_1^2 L_2^2 / \sqrt{a_{11} a_{22}}$ yields

$$\alpha_m^2 \frac{\partial^4 \delta\Phi}{\partial z_1^4} + 2\alpha_m \gamma_m \frac{\partial^4 \delta\Phi}{\partial z_1^3 \partial z_2} + 2\mu \frac{\partial^4 \delta\Phi}{\partial z_1^2 \partial z_2^2} + 2\frac{\delta_m}{\alpha_m} \frac{\partial^4 \delta\Phi}{\partial z_1 \partial z_2^3} + \frac{1}{\alpha_m} \frac{\partial^4 \delta\Phi}{\partial z_2^4} =$$

$$\frac{1}{\sqrt{a_{11} a_{22}}} \left[\frac{L_2^2}{R_2} \frac{\partial^2 \delta w}{\partial z_1^2} + \frac{L_1^2}{R_1} \frac{\partial^2 \delta w}{\partial z_2^2} \right] \quad (41)$$

where

$$\alpha_m = \frac{L_2}{L_1} (a_{22}/a_{11})^{1/4} \quad (42a)$$

$$\mu = \frac{2a_{12} + a_{66}}{2\sqrt{a_{11} a_{22}}} \quad (42b)$$

$$\gamma_m = - \frac{a_{26}}{(a_{11} a_{22})^{3/4}} \quad (42c)$$

and

$$\delta_m = - \frac{a_{16}}{(a_{11} a_{22})^{3/4}} \quad (42d)$$

The next step in the nondimensionalization involves the buckling equation given by equation (36c). To express this equation in terms of the buckling displacement δw and stress function $\delta\Phi$, the equations defining the stress function and the constitutive equations given by equations (35d) through (35f) are used. Substituting equations (37) and (35d) through (35f) into equation (36c) and simplifying gives

$$\begin{aligned}
 & D_{11} \frac{\partial^4 \delta w}{\partial s_1^4} + 4D_{16} \frac{\partial^4 \delta w}{\partial s_1^3 \partial s_2} + 2(D_{12} + 2D_{66}) \frac{\partial^4 \delta w}{\partial s_1^2 \partial s_2^2} + 4D_{26} \frac{\partial^4 \delta w}{\partial s_1 \partial s_2^3} + D_{22} \frac{\partial^4 \delta w}{\partial s_2^4} \\
 & + \frac{1}{R_1} \frac{\partial^2 \delta \Phi}{\partial s_2^2} + \frac{1}{R_2} \frac{\partial^2 \delta \Phi}{\partial s_1^2} + q_1 \frac{\partial \delta w}{\partial s_1} + q_2 \frac{\partial \delta w}{\partial s_2} - N_1 \frac{\partial^2 \delta w}{\partial s_1^2} - N_2 \frac{\partial^2 \delta w}{\partial s_2^2} - 2N_{12} \frac{\partial^2 \delta w}{\partial s_1 \partial s_2} = 0
 \end{aligned}
 \tag{43}$$

Substituting the nondimensional coordinates defined by equation (40) into

equation (43), multiplying through by $L_1^2 L_2^2 / \sqrt{D_{11} D_{22}}$ yields

$$\begin{aligned}
 & \alpha_b^2 \frac{\partial^4 \delta w}{\partial z_1^4} + 4\alpha_b \gamma_b \frac{\partial^4 \delta w}{\partial z_1^3 \partial z_2} + 2\beta \frac{\partial^4 \delta w}{\partial z_1^2 \partial z_2^2} + 4\frac{\delta_b}{\alpha_b} \frac{\partial^4 \delta w}{\partial z_1 \partial z_2^3} + \frac{1}{\alpha_b} \frac{\partial^4 \delta w}{\partial z_2^4} \\
 & + \frac{L_1^2}{R_1 \sqrt{D_{11} D_{22}}} \frac{\partial^2 \delta \Phi}{\partial z_2^2} + \frac{L_2^2}{R_2 \sqrt{D_{11} D_{22}}} \frac{\partial^2 \delta \Phi}{\partial z_1^2} + \tilde{q}_1 \frac{\partial \delta w}{\partial z_1} + \tilde{q}_2 \frac{\partial \delta w}{\partial z_2} \\
 & - K_1 \pi^2 \frac{\partial^2 \delta w}{\partial z_1^2} - K_2 \pi^2 \frac{\partial^2 \delta w}{\partial z_2^2} - 2\frac{K_{12} \pi^2}{\alpha_b} \frac{\partial^2 \delta w}{\partial z_1 \partial z_2} = 0
 \end{aligned}
 \tag{44}$$

where the nondimensional parameters appearing in this equation are given by

$$\alpha_b = \frac{L_2}{L_1} (D_{11}/D_{22})^{1/4}
 \tag{45a}$$

$$\beta = \frac{D_{12} + 2D_{66}}{\sqrt{D_{11} D_{22}}}
 \tag{45b}$$

$$\gamma_b = \frac{D_{16}}{(D_{11} D_{22})^{1/4}}
 \tag{45c}$$

$$\delta_b = \frac{D_{26}}{(D_{11} D_{22})^{1/4}}
 \tag{45d}$$

$$K_1 = \frac{N_1 L_2^2}{\pi^2 \sqrt{D_{11} D_{22}}} \quad (45e)$$

$$K_2 = \frac{N_2 L_1^2}{\pi^2 \sqrt{D_{11} D_{22}}} \quad (45f)$$

$$K_{12} = \frac{N_{12} L_2^2}{\pi^2 (D_{11} D_{22})^{1/4}} \quad (45g)$$

$$\tilde{q}_1 = \frac{q_1 L_1 L_2^2}{\sqrt{D_{11} D_{22}}} \quad (45h)$$

$$\tilde{q}_2 = \frac{q_2 L_2 L_1^2}{\sqrt{D_{11} D_{22}}} \quad (45i)$$

To obtain equations of order one, a new stress resultant function defined by

$$\delta F = \delta \Phi / \sqrt{D_{11} D_{22}} \quad (46)$$

is introduced into equations (44) and (41). Equation (44) becomes

$$\begin{aligned} & \alpha_b^2 \frac{\partial^4 \delta w}{\partial z_1^4} + 4\alpha_b \gamma_b \frac{\partial^4 \delta w}{\partial z_1^3 \partial z_2} + 2\beta \frac{\partial^4 \delta w}{\partial z_1^2 \partial z_2^2} + 4 \frac{\delta_b}{\alpha_b} \frac{\partial^4 \delta w}{\partial z_1 \partial z_2^3} + \frac{1}{\alpha_b} \frac{\partial^4 \delta w}{\partial z_2^4} \\ & + \frac{L_1^2}{R_1} \frac{\partial^2 \delta F}{\partial z_2^2} + \frac{L_2^2}{R_2} \frac{\partial^2 \delta F}{\partial z_1^2} + \tilde{q}_1 \frac{\partial \delta w}{\partial z_1} + \tilde{q}_2 \frac{\partial \delta w}{\partial z_2} \\ & - K_1 \pi^2 \frac{\partial^2 \delta w}{\partial z_1^2} - K_2 \pi^2 \frac{\partial^2 \delta w}{\partial z_2^2} - 2 \frac{K_{12} \pi^2}{\alpha_b} \frac{\partial^2 \delta w}{\partial z_1 \partial z_2} = 0 \end{aligned} \quad (47)$$

Similarly, substituting equation (46) into equation (41) and simplifying gives

$$\alpha_m^2 \frac{\partial^4 \delta F}{\partial z_1^4} + 2\alpha_m \gamma_m \frac{\partial^4 \delta F}{\partial z_1^3 \partial z_2} + 2\mu \frac{\partial^4 \delta F}{\partial z_1^2 \partial z_2^2} + 2 \frac{\delta_m}{\alpha_m} \frac{\partial^4 \delta F}{\partial z_1 \partial z_2^3} + \frac{1}{\alpha_m} \frac{\partial^4 \delta F}{\partial z_2^4} =$$

$$\frac{1}{\sqrt{a_{11} a_{22} D_{11} D_{22}}} \left[\frac{L_2^2}{R_2} \frac{\partial^2 \delta w}{\partial z_1^2} + \frac{L_1^2}{R_1} \frac{\partial^2 \delta w}{\partial z_2^2} \right] \quad (48)$$

The term given by

$$\left[\frac{1}{12 \sqrt{a_{11} a_{22} D_{11} D_{22}}} \right]^{1/2}$$

has dimension 1/t, where t is the shell wall thickness. To get the equation to a form of order one, a nondimensional displacement δW is introduced into equation (48); i.e.,

$$\delta W = \delta w \left[\frac{1}{12 \sqrt{a_{11} a_{22} D_{11} D_{22}}} \right]^{1/2} \quad (49)$$

The nondimensional displacement δW defined in equation (49) has character similar to $\delta w/t$. Using equation (49), equation (48) simplifies to

$$\alpha_m^2 \frac{\partial^4 \delta F}{\partial z_1^4} + 2\alpha_m \gamma_m \frac{\partial^4 \delta F}{\partial z_1^3 \partial z_2} + 2\mu \frac{\partial^4 \delta F}{\partial z_1^2 \partial z_2^2} + 2 \frac{\delta_m}{\alpha_m} \frac{\partial^4 \delta F}{\partial z_1 \partial z_2^3} + \frac{1}{\alpha_m} \frac{\partial^4 \delta F}{\partial z_2^4} =$$

$$\sqrt{12} \{ Z_2 \frac{\partial^2 \delta W}{\partial z_1^2} + Z_1 \frac{\partial^2 \delta W}{\partial z_2^2} \} \quad (50)$$

where

$$Z_1 = \frac{L_1^2}{R_1 \sqrt{12} [a_{11} a_{22} D_{11} D_{22}]^{1/4}} \quad (51a)$$

$$Z_2 = \frac{L_2^2}{R_2 \sqrt{12} [a_{11} a_{22} D_{11} D_{22}]^{1/4}} \quad (51b)$$

Equation (47) also simplifies to

$$\begin{aligned}
 & \alpha_b^2 \frac{\partial^4 \delta W}{\partial z_1^4} + 4\alpha_b \gamma \frac{\partial^4 \delta W}{\partial z_1^3 \partial z_2} + 2\beta \frac{\partial^4 \delta W}{\partial z_1^2 \partial z_2^2} + 4\frac{\delta}{\alpha_b} \frac{\partial^4 \delta W}{\partial z_1 \partial z_2^3} + \frac{1}{\alpha_b} \frac{\partial^4 \delta W}{\partial z_2^4} \\
 & + \sqrt{12} [Z_1 \frac{\partial^2 \delta F}{\partial z_2^2} + Z_2 \frac{\partial^2 \delta F}{\partial z_1^2}] + \tilde{q}_1 \frac{\partial \delta W}{\partial z_1} + \tilde{q}_2 \frac{\partial \delta W}{\partial z_2} \\
 & - K_1 \pi^2 \frac{\partial^2 \delta W}{\partial z_1^2} - K_2 \pi^2 \frac{\partial^2 \delta W}{\partial z_2^2} - 2 \frac{K_{12} \pi^2}{\alpha_b} \frac{\partial^2 \delta W}{\partial z_1 \partial z_2} = 0
 \end{aligned} \tag{52}$$

Equation (50) can be expressed in operator form as

$$D_m(\delta F) - \sqrt{12} D_c(\delta W) = 0 \tag{53}$$

where

$$D_m(\delta F) \equiv \alpha_m^2 \frac{\partial^4 \delta F}{\partial z_1^4} + 2\alpha_m \gamma_m \frac{\partial^4 \delta F}{\partial z_1^3 \partial z_2} + 2\mu \frac{\partial^4 \delta F}{\partial z_1^2 \partial z_2^2} + 2\frac{\delta}{\alpha_m} \frac{\partial^4 \delta F}{\partial z_1 \partial z_2^3} + \frac{1}{\alpha_m} \frac{\partial^4 \delta F}{\partial z_2^4} \tag{54a}$$

and

$$D_c(\delta W) \equiv Z_2 \frac{\partial^2 \delta W}{\partial z_1^2} + Z_1 \frac{\partial^2 \delta W}{\partial z_2^2} \tag{54b}$$

The operators D_m and D_c are referred to herein as the membrane stiffness operator and the curvature operator, respectively.

To get equation (52) into the desired form, it is necessary to express the nondimensional stress resultants K_1 , K_2 , K_{12} , \tilde{q}_1 , and \tilde{q}_2 (see equations (45)) in terms of a loading parameter \tilde{p} . These relationships are given by

$$K_1 = -\ell_1 g_1(z_1, z_2) \tilde{p} \tag{55a}$$

$$K_2 = -\ell_2 g_2(z_1, z_2) \tilde{p} \tag{55b}$$

$$K_{12} = \ell_3 g_3(z_1, z_2) \tilde{p} \tag{55c}$$

$$\tilde{q}_1 = -\ell_4 g_4(z_1, z_2) \tilde{p} \quad (55d)$$

$$\tilde{q}_2 = -\ell_5 g_5(z_1, z_2) \tilde{p} \quad (55e)$$

where the minus signs are used to make compression loads produce positive values of the critical loading parameter. The parameters $\ell_1, \ell_2, \ell_3, \ell_4$, and ℓ_5 are load factors that indicate the ratio of the nondimensional membrane stress resultants and surface tractions prior to buckling. The functions $g_1(z_1, z_2)$ through $g_5(z_1, z_2)$ indicate the spatial variation of the nondimensional membrane stress resultants and surface tractions. Using these relations, equation (52) is expressed in operator form as

$$D_b(\delta W) + \sqrt{12} D_c(\delta F) = \tilde{p} K_g(\delta W) \quad (56)$$

where the operators are defined by

$$D_b(\delta W) \equiv \alpha_b^2 \frac{\partial^4 \delta W}{\partial z_1^4} + 4\alpha_b \gamma_b \frac{\partial^4 \delta W}{\partial z_1^3 \partial z_2} + 2\beta \frac{\partial^4 \delta W}{\partial z_1^2 \partial z_2^2} + 4 \frac{\delta_b}{\alpha_b} \frac{\partial^4 \delta W}{\partial z_1 \partial z_2^3} + \frac{1}{\alpha_b} \frac{\partial^4 \delta W}{\partial z_2^4} \quad (57)$$

$$K_g(\delta W) \equiv -\ell_1 g_1(z_1, z_2) \pi^2 \frac{\partial^2 \delta W}{\partial z_1^2} - \ell_2 g_2(z_1, z_2) \pi^2 \frac{\partial^2 \delta W}{\partial z_2^2} + 2\ell_3 g_3(z_1, z_2) \frac{\pi^2}{\alpha_b} \frac{\partial^2 \delta W}{\partial z_1 \partial z_2} - \ell_4 g_4(z_1, z_2) \frac{\partial \delta W}{\partial z_1} - \ell_5 g_5(z_1, z_2) \frac{\partial \delta W}{\partial z_2} \quad (58)$$

The operators D_b and K_g are referred to herein as the bending stiffness and geometric stiffness operators, respectively.

Equations (53) and (56) constitute the eigenvalue boundary-value problem for buckling of doubly-curved shallow shells. The smallest value of the loading parameter \tilde{p} for which the equations are satisfied constitutes buckling of the shell. The equations are nondimensional and are of order

one. Thus, the magnitude of the parameters multiplying the derivatives is a direct indication of the effect each term in the equations will have on the solution of a given problem. The parameters Z_1 and Z_2 are generalizations of the Batdorf Z parameter presented in references 11 through 13 for isotropic cylindrical panels. These generalizations of the Batdorf Z parameter rely heavily on the work presented by Stein in reference 8, and thus are referred to herein as the generalized Batdorf-Stein Z parameters. As the shell approaches a flat plate, the parameters Z_1 and Z_2 approach zero and the equations uncouple.

Parameters in Terms of Membrane Stiffnesses

The parameters α_m , μ , γ_m , δ_m , Z_1 , and Z_2 have been given in terms of the coefficients of the inverted form of the membrane constitutive equation. Expressions for these parameters in terms of the usual membrane stiffness coefficients are obtained as follows.

First, inverting the membrane stiffness matrix [A] associated with equations (35) yields

$$a_{11} = (A_{22}A_{66} - A_{26}^2)/\det(A) \quad (59a)$$

$$a_{22} = (A_{11}A_{66} - A_{16}^2)/\det(A) \quad (59b)$$

$$a_{12} = (A_{16}A_{26} - A_{12}A_{66})/\det(A) \quad (59c)$$

$$a_{66} = (A_{11}A_{22} - A_{12}^2)/\det(A) \quad (59d)$$

$$a_{16} = (A_{12}A_{26} - A_{16}A_{22})/\det(A) \quad (59e)$$

$$a_{26} = (A_{12}A_{16} - A_{11}A_{26})/\det(A) \quad (59f)$$

where

$$\det(A) = (A_{11}A_{22} - A_{12}^2)A_{66} - A_{11}A_{26}^2 - A_{22}A_{16}^2 + 2A_{12}A_{16}A_{26} \quad (59g)$$

Substituting these expressions into the expressions for the nondimensional parameters gives

$$\alpha_m = \frac{L_2}{L_1} \left[\frac{A_{11}A_{66} - A_{16}^2}{A_{22}A_{66} - A_{26}^2} \right]^{1/4} \quad (60a)$$

$$\mu = \frac{A_{11}A_{22} - A_{12}^2 - 2A_{12}A_{66} + 2A_{16}A_{26}}{2 \left[(A_{11}A_{66} - A_{16}^2)(A_{22}A_{66} - A_{26}^2) \right]^{1/2}} \quad (60b)$$

$$\gamma_m = \frac{A_{11}A_{26} - A_{12}A_{16}}{\left[(A_{11}A_{66} - A_{16}^2)^3 (A_{22}A_{66} - A_{26}^2) \right]^{1/4}} \quad (60c)$$

and

$$\delta_m = \frac{A_{22}A_{16} - A_{12}A_{26}}{\left[(A_{11}A_{66} - A_{16}^2)(A_{22}A_{66} - A_{26}^2) \right]^{1/4}} \quad (60d)$$

$$Z_1 = \frac{L_1^2}{R_1} \left[\frac{(A_{11}A_{22} - A_{12}^2)A_{66} - A_{11}A_{26}^2 - A_{22}A_{16}^2 + 2A_{12}A_{16}A_{26}}{12 \left[(A_{11}A_{66} - A_{16}^2)(A_{22}A_{66} - A_{26}^2)D_{11}D_{22} \right]^{1/2}} \right]^{1/2} \quad (60e)$$

$$Z_2 = \frac{L_2^2}{R_2} \left[\frac{(A_{11}A_{22} - A_{12}^2)A_{66} - A_{11}A_{26}^2 - A_{22}A_{16}^2 + 2A_{12}A_{16}A_{26}}{12 \left[(A_{11}A_{66} - A_{16}^2)(A_{22}A_{66} - A_{26}^2)D_{11}D_{22} \right]^{1/2}} \right]^{1/2} \quad (60f)$$

For the case when A_{16} and A_{26} are zero-valued; $\gamma_m = 0$, $\delta_m = 0$, and the remaining nonzero parameters simplify to

$$\alpha_m = \frac{L_2}{L_1} \left[\frac{A_{11}}{A_{22}} \right]^{1/4} \quad (60g)$$

$$\mu = \frac{A_{11}A_{22} - A_{12}^2 - 2A_{12}A_{66}}{2A_{66}\sqrt{A_{11}A_{22}}} \quad (60h)$$

$$Z_1 = \frac{L_1^2}{R_1} \left[\frac{A_{11}A_{22} - A_{12}^2}{12\sqrt{A_{11}A_{22}D_{11}D_{22}}} \right]^{1/2} \quad (60i)$$

$$Z_2 = \frac{L_2^2}{R_2} \left[\frac{A_{11}A_{22} - A_{12}^2}{12\sqrt{A_{11}A_{22}D_{11}D_{22}}} \right]^{1/2} \quad (60j)$$

For the case of an isotropic material, the nonzero parameters are given by

$$\alpha_m = \frac{L_2}{L_1} \quad (60k)$$

$$\mu = 1 \quad (60l)$$

$$Z_1 = \frac{L_1^2}{R_1 t} (1 - \nu^2)^{1/2} \quad (60m)$$

$$Z_2 = \frac{L_2^2}{R_2 t} (1 - \nu^2)^{1/2} \quad (60n)$$

where t is the total plate thickness.

Reduction to a Single Equation in Terms of W

Generalized Donnell-Stein Equation. Donnell showed (see references 11 through 13) that a single eighth-order differential equation could be obtained for isotropic cylindrical shells by eliminating the stress function appearing in the buckling equations. This task is performed by applying successive differentiation to obtain a single equation referred to by Batdorf as an escalated equation (see reference 14). Applying Donnell's approach to a doubly-curved shallow shell, equation (53) is operated on by the curvature operator to give

$$D_c (D_m (\delta F)) = \sqrt{12} D_c^2 (\delta W) \quad (61a)$$

Using the fact the the differential operators in equation (61) are linear, their order of operation can be interchanged to give

$$D_m(D_c(\delta F)) = \sqrt{12} D_c^2(\delta W) \quad (61b)$$

Next, operating on equation (56) with the membrane stiffness operator yields

$$D_m(D_b(\delta W)) + \sqrt{12} D_m(D_c(\delta F)) = \tilde{p}D_m K_g(\delta W) \quad (62)$$

Substituting the right-hand-side of equation (61b) into equation (62) yields an eighth-order partial differential equation referred to herein as the generalized Donnell-Stein equation; i.e.,

$$D_m(D_b(\delta W)) + 12D_c^2(\delta W) = \tilde{p}D_m K_g(\delta W) \quad (63)$$

Modified Batdorf-Stein Equation. The doubly-curved shallow shell counterpart to Batdorf's equation is obtained by expressing equation (53) as

$$\delta F = \sqrt{12} D_m^{-1}(D_c(\delta W)) \quad (64)$$

where $D_m^{-1}(\)$ denotes the inverse differential operator (anti-derivatives) which symbolically represents integration. A detailed account of the use of inverse differential operators is given in references 11 through 14. Using the fact that the differential operator and inverse differential operator in equation (64) are linear, their order of operation can be interchanged to give

$$\delta F = \sqrt{12} D_c(D_m^{-1}(\delta W)) \quad (65)$$

Substituting equation (65) into equation (56) yields the desired equation; i.e.,

$$D_b(\delta W) + 12D_c^2[D_m^{-1}(\delta W)] - \tilde{p}K_g(\delta W) = 0 \quad (66)$$

This integro-differential equation is a generalization of Batdorf's modified equilibrium equation presented in reference 12 and is referred to herein as the Modified Batdorf-Stein equation.

Implied Membrane Boundary Conditions. As pointed out by Batdorf in references 11 through 13, the original Donnell and Modified Batdorf equations for isotropic cylindrical shells implicitly prescribe boundary conditions on the membrane displacements and stress resultants. This attribute of these equations is a direct consequence of the elimination of the stress resultant function. Thus, the Generalized Donnell-Stein and Modified Batdorf-Stein equations presented in this paper also possess this attribute. Results presented by Batdorf [11-13], Rehfield and Hallauer [15], and Sobel, et. al. [16] suggest that the effect of membrane boundary conditions on the predicted buckling load and mode shape of shallow isotropic cylindrical shells may, in several cases, be small. For these cases, buckling results obtained from the Generalized Donnell-Stein and Modified Batdorf-Stein equations give reasonable estimates of the collapse load. This information, however, is not generally known for shallow laminated composite shells. It does seem reasonable that, for the class of slightly curved shells which are not imperfection sensitive, the coupling of membrane and bending behavior is mild enough that the analytical predictions of buckling that are obtained from the Generalized Donnell-Stein and Modified Batdorf-Stein equations are reasonably accurate and thus useful in preliminary design of shallow shells.

The actual membrane boundary conditions implied by solutions to the Generalized Donnell-Stein and Modified Batdorf-Stein equations are determined from the displacement form of the membrane equilibrium equations. These equations are obtained by substituting constitutive equations (35a)

through (35c) into membrane equilibrium equations (36a) and (36b). This step yields two coupled partial differential equations that relate the unknown membrane buckling displacements δu_1 and δu_2 to the known transverse buckling displacement δw . Using differentiation, the two coupled equations are converted to two independent uncoupled equations; i.e., one equation relating δu_1 to δw and another relating δu_2 to δw . Performing these operations and nondimensionalizing the resulting equations yields the following equations for the special case of A_{16} and A_{26} being zero-valued.

$$D_m(\delta U_1) = - \left[\alpha_m^2 Z_1 + \frac{A_{12}}{\sqrt{A_{11}A_{22}}} Z_2 \right] \frac{\partial^3 \delta W}{\partial z_1^3} - \left[\left(2\mu + \frac{A_{12}}{\sqrt{A_{11}A_{22}}} \right) Z_1 - \frac{1}{\alpha_m^2} Z_2 \right] \frac{\partial^3 \delta W}{\partial z_1 \partial z_2^2} \quad (67a)$$

$$D_m(\delta U_2) = - \left[\frac{A_{12}}{\sqrt{A_{11}A_{22}}} Z_1 + \frac{1}{\alpha_m^2} Z_2 \right] \frac{\partial^3 \delta W}{\partial z_2^3} - \left[\left(2\mu + \frac{A_{12}}{\sqrt{A_{11}A_{22}}} \right) Z_2 - \alpha_m^2 Z_1 \right] \frac{\partial^3 \delta W}{\partial z_1^2 \partial z_2} \quad (67b)$$

where the nondimensional membrane displacements δU_1 and δU_2 are given by

$$\delta U_1 = L_1 \frac{A_{11}A_{22} - A_{12}^2}{12\sqrt{A_{11}A_{22}}D_{11}D_{22}} \delta u_1 \quad (68a)$$

and

$$\delta U_2 = L_2 \frac{A_{11}A_{22} - A_{12}^2}{12\sqrt{A_{11}A_{22}}D_{11}D_{22}} \delta u_2 \quad (68b)$$

These differential equations are generalizations of those presented by Donnell (see reference 11) for isotropic cylindrical shells.

A general method of determining the membrane boundary conditions implied by δW is to expand both δU_1 and δU_2 into full double Fourier series and then determine the Fourier coefficients using the orthogonality of the functions forming the double Fourier series. Once the Fourier series are determined, stress resultants are computed directly from the membrane constitutive equations. The boundary conditions are identified by examining the functional form of the Fourier series for the displacements and stress resultants on the boundary of the shell.

Approximate Solution of the Buckling Equations

Simple closed form solutions to equations (63) and (66) are not readily available since the geometric stiffness operator generally has variable coefficients and both the geometric stiffness and bending stiffness operators have odd-combination mixed partial derivatives (e.g., three derivatives with respect to z_1 and one with respect to z_2). Approximate solutions, however, can be obtained by methods such as the Bubnov-Galerkin method (see reference 12 for example). The usual way of solving equations (63) and (66) by the Bubnov-Galerkin method involves using series expansions for δF and δW that satisfy all the boundary conditions of a given problem. These expressions are then substituted into equations (63) and (66) to obtain two residuals (one for each equation) since the series expansions generally do not satisfy the two differential equations. Then, the residuals are expanded in the same series (i.e., same basis of the solution space) and the components of the residuals are forced to be zero-valued in an integrated sense. This process results in a generalized algebraic eigenvalue problem whose eigenvector includes the buckling displacement modal amplitudes and the stress function amplitudes.

Often in performing analysis for preliminary design, or parametric study, it is desirable to simplify the analysis as much as possible. One such simplification was introduced in shell buckling analysis by Batdorf (see references 12 and 13). The method associated with this simplification consists of a Bubnov-Galerkin solution to Batdorf's counterpart of the Modified Batdorf-Stein equation. The results and discussion presented by Batdorf in references 12 and 13 suggest that use of the Modified Batdorf-Stein equation is preferred to the use of the Generalized Donnell-Stein equation when applying the Bubnov-Galerkin method. By eliminating the stress function using the inverse differential operator, the size of the generalized algebraic eigenvalue problem to be solved in the Bubnov-Galerkin method is significantly reduced, and thus the attractiveness of the analysis for parametric study is greatly increased. The application of this method to the Modified Batdorf-Stein equation is outlined in the subsequent section.

Bubnov-Galerkin Formulation for the Modified Batdorf-Stein Equation

To obtain an approximate solution to equation (66), the nondimensional transverse buckling displacement is expressed as

$$\delta W \rightarrow \delta W_{MN} = \sum_{p=1}^M \sum_{q=1}^N a_{pq} \Phi_p(z_1) \Psi_q(z_2) \quad (69)$$

where the basis functions $\Phi_p(z_1)$ and $\Psi_q(z_2)$ are selected such that δW_{MN} satisfies all the boundary conditions of the given problem, and are at least a linearly independent set. Substituting equation (69) into equation (66) yields a residual since the assumed displacement series does not satisfy the integro-differential equation, equation (66). The residual is given by

$$R_{MN} = \sum_{p=1}^M \sum_{q=1}^N a_{pq} \{ D_b (\Phi_p \Psi_q) + 12D_c^2 (D_m^{-1} (\Phi_p \Psi_q)) - \tilde{p}K_g (\Phi_p \Psi_q) \} = 0 \quad (70)$$

and is dependent on the number of terms taken in the series. The evaluation of the terms involving D_b and K_g are straightforward, however, the evaluation of the term involving the inverse operator is somewhat involved. The general procedure for determining $D_m^{-1}(\Phi_p \Psi_q)$ is to first expand $D_m^{-1}(\delta W)$ in a general double Fourier series as if it is an arbitrary function of two variables (see reference 14). Next, the condition that $D_m(D_m^{-1}(\delta W)) = \delta W$ is enforced by operating on the Fourier series with D_m (i.e., the left-hand-side of the equality) and then substituting equation (69) for δW appearing on the right-hand-side of the equality. The Fourier coefficients are then determined using the orthogonality property of the functions forming the basis of the Fourier series. The resulting equations yield the following equation

$$D_m^{-1}(\delta W) = \frac{D_{00}}{4} + \sum_{p=1}^M \sum_{q=1}^N D_m^{-1}(\Phi_p \Psi_q) a_{pq} \quad (71)$$

The leading constant term is of no significance in the Bubnov-Galerkin solution since it vanishes once $D_c^2(D_m^{-1}(\delta W))$ is computed.

In the Bubnov-Galerkin method, the residual is assumed to be a function that can be expanded in the same basis functions as δW ; i.e., it is assumed that the residual can be expressed as

$$R_{MN} = \sum_{p=1}^M \sum_{q=1}^N r_{pq} \Phi_p(z_1) \Psi_q(z_2) \quad (72)$$

The coefficients r_{pq} represent the components of the residual in the function space spanned by Φ_p and Ψ_q . The coefficients r_{pq} are determined by

multiplying equation (72) through by the set of functions $\Phi_m \Psi_n$ (for $m = 1, 2, \dots, M$ and $n = 1, 2, \dots, N$) and integrating the resulting equation over the region on which the boundary-value problem is defined. This step gives

$$\int_0^1 \int_0^1 R_{MN} \Phi_m(z_1) \Psi_n(z_1) dz_1 dz_2 = \sum_{p=1}^M \sum_{q=1}^N r_{pq} F_{pm} H_{qn} \quad (73)$$

where

$$F_{pm} = \int_0^1 \Phi_m(z_1) \Phi_p(z_1) dz_1 \quad (74a)$$

and

$$H_{qn} = \int_0^1 \Psi_n(z_2) \Psi_q(z_2) dz_2 \quad (74b)$$

An approximate solution to the boundary-eigenvalue problem is obtained by requiring that the components of the residual series expansion be zero-valued. Noting that the F_{pm} and H_{qn} coefficients of the right-hand-side of equation (73) constitute a nonsingular coefficient matrix of the linear system of equations defined by equation (72), a sufficient condition for the components of the residual series to vanish is given by

$$\int_0^1 \int_0^1 R_{MN} \Phi_m(z_1) \Psi_n(z_1) dz_1 dz_2 = 0 \quad (75)$$

for all combinations of $m = 1, 2, \dots, M$ and $n = 1, 2, \dots, N$. More precisely, the following equations must be satisfied.

$$\sum_{p=1}^M \sum_{q=1}^N K_{mnpq} a_{pq} = \tilde{p} \sum_{p=1}^M \sum_{q=1}^N K_{mnpq}^G a_{pq} \quad (76)$$

where K_{mnpq} constitutes the stiffness matrix given by

$$K_{mnpq} = K_{mnpq}^B + K_{mnpq}^C \quad (77a)$$

The stiffness coefficients associated with bending are given by

$$K_{mnpq}^B = \int_0^1 \int_0^1 D_b (\Phi_p \Psi_q) \Phi_m \Psi_n dz_1 dz_2 \quad (77b)$$

and the stiffness coefficients associated with shell curvature are given by

$$K_{mnpq}^C = \int_0^1 \int_0^1 12D_c^2 (D_m^{-1} (\Phi_p \Psi_q)) \Phi_m \Psi_n dz_1 dz_2 \quad (77c)$$

The term K_{mnpq}^G constitutes the geometric stiffness matrix and its coefficients are given by

$$K_{mnpq}^G = \int_0^1 \int_0^1 K_g (\Phi_p \Psi_q) \Phi_m \Psi_n dz_1 dz_2 \quad (77d)$$

Once the specific form of Φ_m and Ψ_n are given, the inverse differential operator can be obtained, the stiffness and geometric stiffness matrices can be computed, and the eigenvalue problem can be solved. Buckling is defined by the smallest value of \tilde{p} that satisfies the generalized algebraic eigenvalue problem defined by equation (76).

Results and Discussion

Following the procedure presented in the previous section of this paper, the buckling behavior of a shell can be determined in terms of α_b , β , γ_b , δ_b , α_m , μ , γ_m , δ_m , Z_1 , and Z_2 . For a given family of laminates, such as the $[(\pm\theta)_n]_s$ laminates ($n = 1, 2, \dots$) described in reference 1, changes in the fiber orientation and stacking sequence of a laminate generally results in changes in all the nondimensional parameters presented herein. Plots showing the dependence of several of the parameters on fiber orientation and

stacking sequence are presented in reference 1. The point to be made is that the parameters are not independent with respect to laminate construction. However, insight into determining, and understanding, the key parameters affecting buckling behavior can be obtained by studying how the parameters vary with respect to laminate construction, and by studying the sensitivity of the buckling behavior with respect to varying each parameter in an independent manner. For example, an indication of the sensitivity of the buckling behavior with respect to variations in these parameters can be obtained from plots of a buckling coefficient as a function of each parameter. To demonstrate this philosophy, some typical results of a parametric study are presented in the next section of this paper for a representative example problem.

Example Problem

The example problem presented in this section is a shallow shell that is loaded on its edges by a uniform shearing traction τ as shown in figure 2. The shell is supported such that the transverse displacement and rotation along the edges are zero-valued (clamped with respect to bending behavior). The basis functions used in the approximate analysis presented herein that satisfy these boundary conditions are given by

$$\Phi_p = \cos(p-1)\pi z_1 - \cos(p+1)\pi z_1 \quad (78a)$$

$$\Psi_q = \cos(q-1)\pi z_2 - \cos(q+1)\pi z_2 \quad (78b)$$

for $p = 1, 2, \dots, M$ and $q = 1, 2, \dots, N$. Associated with these basis functions, and the use of the Modified Batdorf-Stein equation, are implied membrane boundary conditions. To greatly simplify the analysis, the example problem is defined as a shell that has $A_{16} = A_{26} = 0$; i.e., its membrane

behavior is specially orthotropic. The corresponding implied boundary conditions are given by $\delta U_1 = \delta N_{12} = 0$ on the edges $z_1 = 0$ and 1, and $\delta U_2 = \delta N_{12} = 0$ on the other two edges.

Applying the procedure for approximate solution of the Modified Batdorf-Stein equation described in the previous section of this paper yields explicit expressions for the stiffness and geometric stiffness coefficients defined in equations (77). The stiffness coefficients K_{mnpq}^B and geometric stiffness coefficients K_{mnpq}^G are identical to those obtained from a Bubnov-Galerkin analysis of a flat plate and are not presented herein. The contribution of the stiffness coefficients associated with shell curvature to equation (76) is expressed by

$$\begin{aligned} \frac{4}{\pi} \sum_{p=1}^M \sum_{q=1}^N K_{mnpq}^C a_{pq} = & Z(m-1, n-1) a_{m-2, n-2} - \{Z(m-1, n-1) + Z(m+1, n-1)\} a_{m, n-2} + \\ & Z(m+1, n-1) a_{m+2, n-2} - \{Z(m-1, n-1) + Z(m-1, n+1)\} a_{m-2, n} + \\ & \{Z(m-1, n-1) + Z(m-1, n+1) + Z(m+1, n-1) + Z(m+1, n+1)\} a_{m, n} + \\ & - \{Z(m+1, n-1) + Z(m+1, n+1)\} a_{m+2, n} + Z(m-1, n+1) a_{m-2, n+2} + \\ & - \{Z(m-1, n+1) + Z(m+1, n+1)\} a_{m, n+2} + Z(m+1, n+1) a_{m+2, n+2} \end{aligned} \quad (79)$$

where

$$Z(m-1, n-1) = \frac{12[Z_2(m-1)^2 + Z_1(n-1)^2]^2}{\{\alpha_m^2(m-1)^4 + 2\mu(m-1)^2(n-1)^2 + (n-1)^4/\alpha_m^2\}\pi^4} \quad (80)$$

for $m = 1, 2, \dots, M$ and $n = 1, 2, \dots, N$.

Results obtained from the approximate analysis are presented in figures 2 and 3. The buckling resistance of a shell is indicated in these figures by the nondimensional shear buckling coefficient K_s defined by

$$K_s = \frac{\tau L_2^2}{\pi^2 (D_{11} D_{22})^{1/4}} \quad (81)$$

where τ is the applied shearing traction. For the results presented in the figures, the orthotropic parameters (α_b , β , α_m , and μ) and the anisotropic parameters (γ_b , δ_b , γ_m , and δ_m) that are not varied are set equal to one and zero, respectively. This baseline set of values corresponds to an isotropic shell with sides of equal length ($L_1 = L_2$).

Results showing shear buckling coefficient as a function of the Batdorf-Stein shell curvature parameters, Z_1 and Z_2 , are presented in figure 2. Results are shown in this figure for flat plates and for shells with zero, negative, and positive Gaussian curvature with values of Z_1 and Z_2 ranging from 0 to 100. The results presented in figure 2 indicate that the shear buckling resistance of a shell is significantly influenced by shell curvature, especially for the larger values of Z_1 and Z_2 shown in the figure. The results also indicate that the shells with positive Gaussian curvature are the most buckling resistant. Moreover, the shells with positive Gaussian curvature are more buckling resistant than those with negative Gaussian curvature, which are more buckling resistant than those with zero Gaussian curvature. Flat plates exhibit the lowest buckling resistance.

Results showing shear buckling coefficient as a function of the curvature parameters, Z_1 and Z_2 , and the bending anisotropy parameters γ_b

and δ_b (see equations (45c) and (45d)) are presented in figure 3. Results are shown in this figure for flat plates and for shells with positive Gaussian curvature corresponding to $Z_1 = Z_2 = 100$. Values of the anisotropic parameters range from 0 to 0.5. This range of values is considered to be representative of a large class of laminated plates [1]. Results are presented in figure 3 corresponding to both positive and negative directions of the applied shear traction. The distinction of loading direction results from the presence of the bending anisotropy.

The results presented in figure 3 indicate the shear buckling resistance of a shell with positive Gaussian curvature is more sensitive to variations in the anisotropic parameters than a corresponding flat plate. The results show substantial reductions in buckling resistance with increasing values of the anisotropic parameters for shells loaded in positive shear, and similar increases in buckling resistance for shells loaded in negative shear. Similar results were obtained for a corresponding shell with negative Gaussian curvature that indicate the same trend, but not to as large an extent as exhibited by the shell with positive Gaussian curvature.

The results presented in figures 2 and 3 show that varying parameters independently can give insight into the factors driving the structural response. For example, by independently varying the parameters associated with shell curvature it has been found that positive values of Gaussian curvature substantially improve the shear buckling resistance of a shell. In addition, it has been determined that shell curvature can significantly affect the importance of the bending anisotropy on the shear buckling resistance. Both of these observations clearly indicate the benefits of

using nondimensional parameters to formulate the analysis and to perform parametric studies.

Concluding Remarks

A method of deriving nondimensional equations and indentifying the fundamental parameters associated with bifurcation buckling of shallow shells subjected to combined loads has been presented. Analysis has been presented for symmetrically laminated doubly-curved shells that exhibit both membrane and bending anisotropy. The analysis includes equations for nonlinear deformations and buckling of thin elastic shallow shells, and the procedure and rationale used to obtain useful nondimensional forms of the transverse equilibrium and compatibility equations for buckling are discussed. Fundamental parameters of the problem have been identified that explicitly indicate, in a compact manner, how both membrane and bending orthotropy and anisotropy influence buckling behavior. Generalizations of the well-known Batdorf Z parameter for symmetrically laminated shells with full anisotropy have also been presented, as well as generalized forms of Donnell's and Batdorf's equations for shell buckling. In addition, shell boundary conditions and approximate solution methods of the nondimensional boundary-value problem have been briefly discussed.

Results obtained from a Bubnov-Galerkin solution of a representative example problem have also been presented. The results demonstrate the advantages of formulating the analysis in terms of nondimensional parameters and using them to perform parametric studies. The results specifically show that shells with positive Gaussian curvature are much more shear buckling resistant than corresponding flat plates and shells with negative and zero Gaussian curvature. In addition, the results show that the importance of

bending anisotropy on shear buckling resistance is affected by shell curvature.

References

1. Nemeth, M. P.: Importance of Anisotropy on Buckling of Compression-Loaded Symmetric Composite Plates. AIAA Journal, Vol. 24, No. 11, November 1986, pp. 1831-1835.
2. Grenestedt, J. L.: A Study on the Effect of Bending-Twisting Coupling on Buckling Strength. Composite Structures, Vol. 12, No. 4, 1989, pp. 271-290.
3. Almroth, B. O. and Brogan, F. A.: Bifurcation Buckling as an Approximation of the Collapse Load for General Shells. AIAA Journal, Vol. 10, No. 4, April 1972, pp. 463-467.
4. Stein, M. and McElman, J. A.: Buckling of Segments of Toroidal Shells. AIAA Journal, Vol. 3, No. 9, September 1965, pp. 1704-1709.
5. Gerard, G.: Introduction to Structural Stability Theory. McGraw-Hill, Inc., 1962, pp. 129-155.
6. Brush, D. O. and Almroth, B. O.: Buckling of Bars, Plates, and Shells. McGraw-Hill Publishing Co., Inc., 1975, p. 164.
7. Johns, D. J.: Shear Buckling of Isotropic and Orthotropic Plates-A Review. Aeronaut. Res. Council., Rep. Memo R & M No. 3677, 1971.
8. Stein, M.: Postbuckling of Orthotropic Composite Plates Loaded in Compression. Presented at the AIAA/ASME/ASCE/AHS 23rd Structures, Structural Dynamics, and Materials Conference, AIAA Paper No. 82-0778, New Orleans, Louisiana, May 10-12, 1982.
9. Mahayni, M. A.: Thermal Buckling of Shallow Shells. International Journal of Solids and Structures, Vol. 2, 1966, pp. 167-180.
10. Dong, S. B.; Pister, K. S.; and Taylor, R. L.: On the Theory of Laminated Anisotropic Shells and Plates. Journal of the Aerospace Sciences, Vol. 29, September, 1962, pp. 969-975.
11. Batdorf, S. B.: A Simplified Method of Elastic-Stability Analysis for Thin Cylindrical Shells, I - Donnell's Equation. NACA Technical Note No. 1341, June, 1947.
12. Batdorf, S. B.: A Simplified Method of Elastic-Stability Analysis for Thin Cylindrical Shells, II - Modified Equilibrium Equation. NACA Technical Note No. 1342, June, 1947.
13. Batdorf, S. B.: A Simplified Method of Elastic-Stability Analysis for Thin Cylindrical Shells. NACA Technical Report No. 874, 1947.

14. Batdorf, S. B.: On the Application of Inverse Differential Operators to the Solution of Cylinder Buckling and Other Problems. Proceedings of the AIAA/ASME 10th Structures, Structural Dynamics, and Materials Conference, April, 1969.
15. Rehfield, L. W. and Hallauer, W. L., Jr.: Edge Restraint Effect on Buckling of Compressed Curved Panels. AIAA Journal, Vol. 6, No. 1, January 1968, pp. 187-189.
16. Sobel, L. H.; Weller, T.; and Agarwal, B. L.: Buckling of Cylindrical Panels Under Axial Compression. Computers and Structures, Vol. 6, February 1976, pp. 29-35.

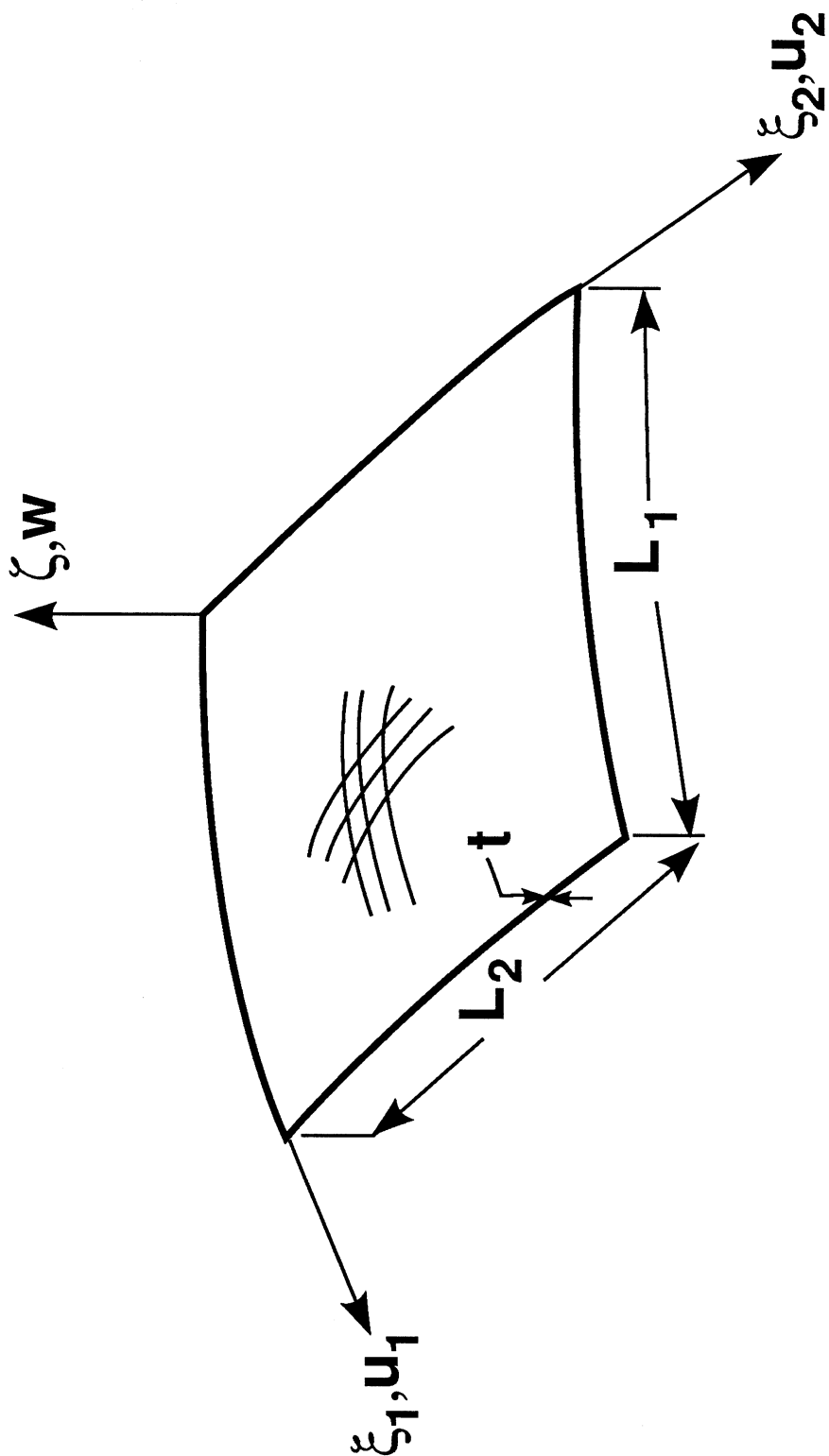

Figure 1. Geometry of a shallow shell.

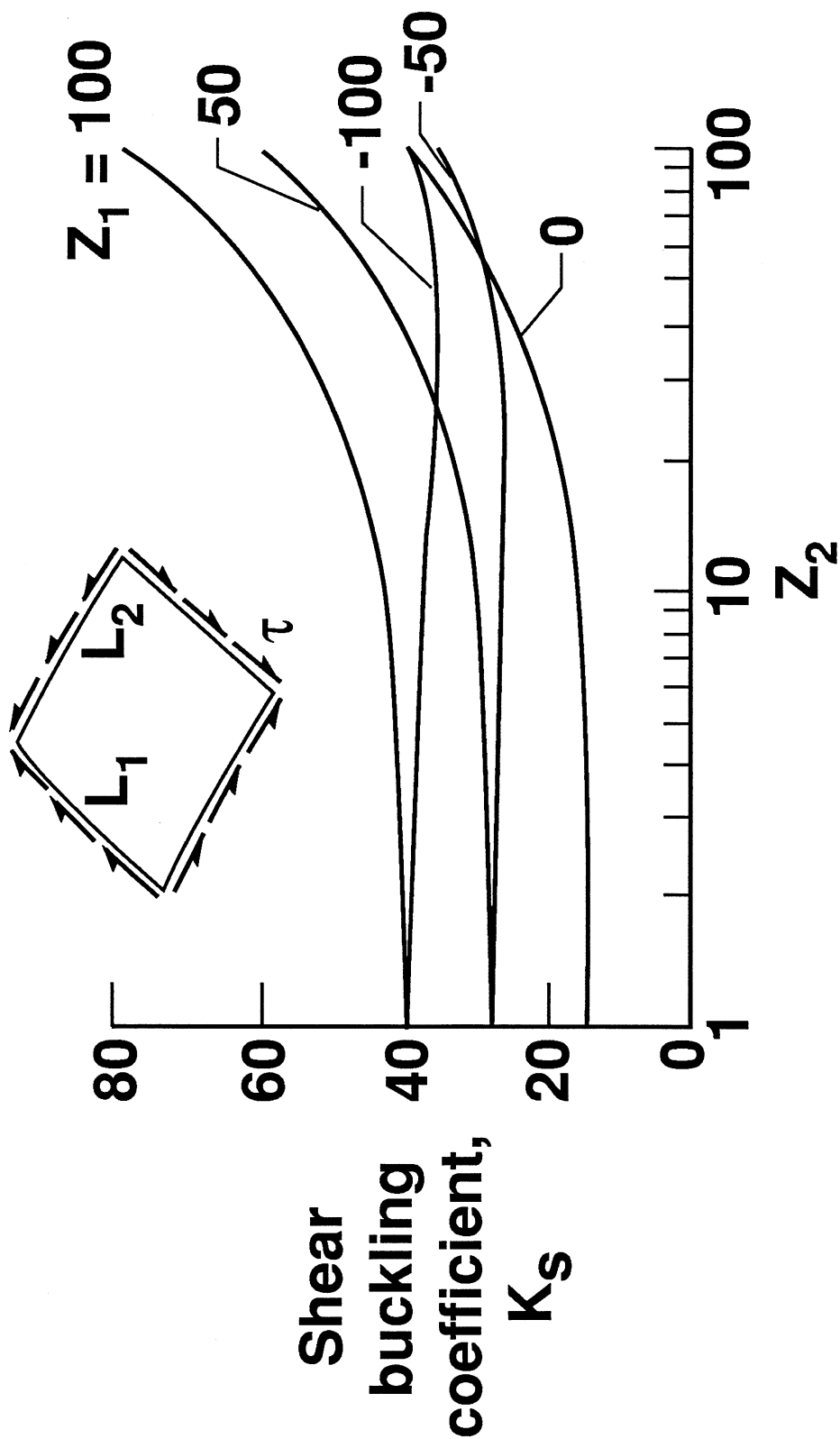

Figure 2. Effect of shell curvature on shear buckling resistance ($L_1/L_2=1$).

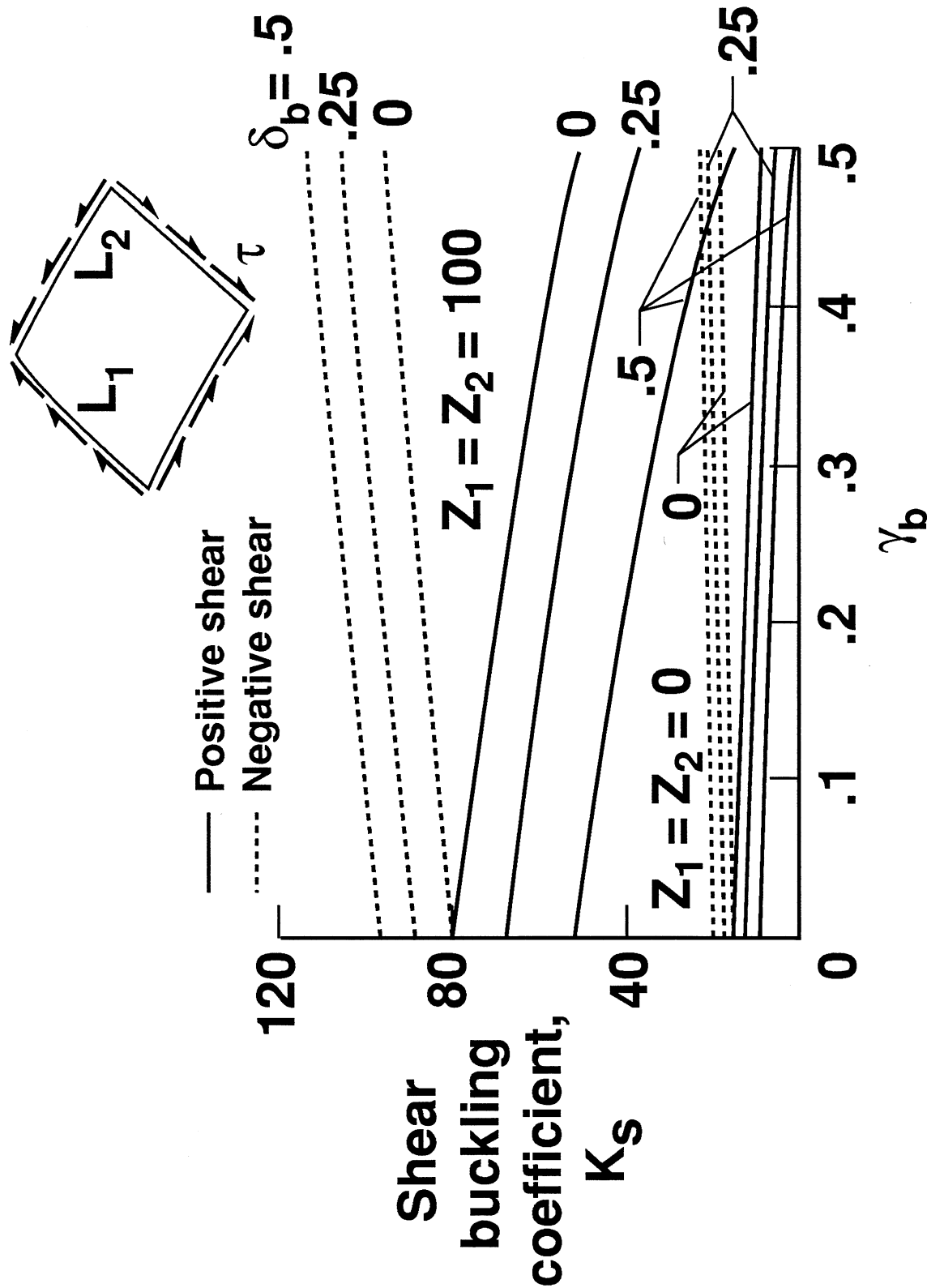

Figure 3. Effects of anisotropic parameters and shell curvature on shear buckling resistance ($L_1/L_2 = 1$). The parameters γ_b and δ_b are nondimensional bending stiffness parameters defined by equations (45c) and (45d).



Report Documentation Page

1. Report No. NASA TM-104060		2. Government Accession No.		3. Recipient's Catalog No.	
4. Title and Subtitle Nondimensional Parameters and Equations for Buckling of Symmetrically Laminated Thin Elastic Shallow Shells				5. Report Date March 1991	
				6. Performing Organization Code	
7. Author(s) Michael P. Nemeth				8. Performing Organization Report No.	
				10. Work Unit No. 505-63-50	
9. Performing Organization Name and Address NASA Langley Research Center Hampton, VA 23665				11. Contract or Grant No.	
				13. Type of Report and Period Covered Technical Memorandum	
12. Sponsoring Agency Name and Address National Aeronautics and Space Administration Washington, DC 20546				14. Sponsoring Agency Code	
15. Supplementary Notes					
16. Abstract <p>A method of deriving nondimensional equations and identifying the fundamental parameters associated with bifurcation buckling of anisotropic shallow shells subjected to combined loads is presented. The procedure and rationale used to obtain useful nondimensional forms of the transverse equilibrium and compatibility equations for buckling are presented. Fundamental parameters are identified that represent the importance of both membrane and bending orthotropy and anisotropy on the results. Moreover, generalizations of the well-known Batdorf Z parameter for symmetrically laminated shells with full anisotropy are presented. Using the nondimensional analysis, generalized forms of Donnell's and Batdorf's equations for shell buckling are also presented, and the shell boundary conditions and approximate solution methods of the boundary-value problem are briefly discussed.</p> <p>Results obtained from a Bubnov-Galerkin solution of a representative example problem are also presented. The results demonstrate the advantages of formulating the analysis in terms of nondimensional parameters and using these parameters for parametric studies.</p>					
17. Key Words (Suggested by Author(s)) nondimensional parameters buckling shells anisotropic shells shell buckling			18. Distribution Statement Unclassified - Unlimited Subject Category 24		
19. Security Classif. (of this report) Unclassified		20. Security Classif. (of this page) Unclassified		21. No. of pages 46	22. Price A03