



**NASA TECHNICAL  
HANDBOOK**

**NASA-HDBK-6003C**

**National Aeronautics and Space Administration  
Washington, DC 20546-0001**

**Approved: 06-20-2008  
Expiration Date: 06-19-2013  
Superseding NASA-HDBK-6003B**

**APPLICATION OF DATA MATRIX IDENTIFICATION SYMBOLS TO  
AEROSPACE PARTS USING DIRECT PART MARKING  
METHODS/TECHNIQUES**

**MEASUREMENT SYSTEM IDENTIFICATION  
INCH-POUND/METRIC**

## NASA-HDBK-6003C

### DOCUMENT HISTORY LOG

Status	Document Revision	Approval Date	Description
Baseline		07-02-2001	Baseline Release
Revision	A	06-17-2002	Incorporates metric unit equivalents in parentheses beside all English measurement units
Revision	B	02-21-2006	<p>Page 28, section 4.2.1.6 – Liquid metal jet (LMJ) process replaced by LENS</p> <p>Incorporates changes from DoD retrofit part marking development and direct part marking (DPM) flight verification tests</p> <p>Incorporates additional inputs in section 4.2.2.2 (Dot Peen)</p> <p>Input into new template; made editorial changes</p> <p>Added Appendix A</p>
Revision	C	06-20-2008	3.2: <u>License Tag Number</u> : Delete the last sentence in the definition that read: “As a minimum, the information should contain the manufacturer’s CAGE code followed by an asterisk (ASCII separator) and trace code (lot, member, or serial number).” This is obsolete language.

**APPROVED FOR PUBLIC RELEASE – DISTRIBUTION IS UNLIMITED**

## NASA-HDBK-6003C

### FOREWORD

This handbook is published by the National Aeronautics and Space Administration (NASA) as a guidance document that provides engineering information; lessons learned; possible options to address technical issues; classification of similar items, materials, or processes; interpretative direction and techniques; and any other type of guidance information that may help the government or its contractors in the design, construction, selection, management, support, or operation of systems, products, processes, or services.

This handbook is approved for use by NASA Headquarters and NASA Centers, including Component Facilities.

This handbook establishes uniform guidance for applying Data Matrix identification symbols to parts used on NASA programs/projects using direct part marking (DPM) methods and techniques.

Requests for information, corrections, or additions to this handbook should be submitted via “Feedback” in the NASA Technical Standards System at <http://standards.nasa.gov>.

*Original Signed By*

---

Michael G. Ryschkewitsch  
NASA Chief Engineer

---

June 20, 2008  
Approval Date

**APPROVED FOR PUBLIC RELEASE – DISTRIBUTION IS UNLIMITED**

# NASA-HDBK-6003C

## TABLE OF CONTENTS

<u>SECTION</u>		<u>PAGE</u>
	DOCUMENT HISTORY LOG .....	2
	FOREWORD .....	3
	TABLE OF CONTENTS.....	4
	LIST OF FIGURES .....	5
	LIST OF TABLES.....	6
<b>1.</b>	<b>SCOPE</b> .....	7
1.1	Purpose.....	7
1.2	Applicability .....	7
<b>2.</b>	<b>REFERENCE DOCUMENTS</b> .....	8
2.1	Government Documents .....	8
2.2	Non-Government Documents .....	8
<b>3.</b>	<b>ACRONYMS AND DEFINITIONS</b> .....	9
3.1	Acronyms .....	9
3.2	Definitions.....	10
<b>4.</b>	<b>GUIDANCE</b> .....	15
4.1	Part Tracking System Advancements .....	15
4.2	Marking Methods.....	16
4.3	Background .....	56
4.4	Key Word Listing.....	58
<b>APPENDIX A</b>	<b>MISSE PROGRAM INFORMATION</b> .....	59

APPROVED FOR PUBLIC RELEASE – DISTRIBUTION IS UNLIMITED

## NASA-HDBK-6003C

### LIST OF FIGURES

<b>Figure</b>	<b>Title</b>	<b>Page</b>
1	Preferred Mold Profile.....	18
2	Preferred Cell Spacing.....	19
3	Laser Cutting Pattern Used to Cut Symbol Data Cells into Sand-Cast Mold.....	20
4	Cross Section of Sand-Cast Symbol Designed to Provide Artificial Contrast for Successful Decoding .....	20
5	Photograph of Sand-Cast Marking .....	21
6	Unacceptable Ink-jet Markings .....	22
7	Material Fused to a Surface Using the Laser Bonding Process.....	23
8	Unacceptable Laser Bonding Markings .....	24
9	Schematic Illustration of the LENS Process .....	25
10	Spherical Mold Profile .....	26
11	Camera Image of Spherical Profile .....	26
12	Direct Part Marking Using LENS (A Molybdenum Disk Marked with Stainless-Steel Raised Lettering).....	27
13	Data Matrix System Stencil Structure .....	29
14	Dot-peen Patterns Used to Create Individual Data Cells .....	30
15	Preferred Stylus-to-Target Configuration.....	31
16	Preferred Dot-peen Stylus Configuration .....	32
17	Acceptable Dot Size Range Using 120° Stylus with 0.005-in. (0.127 mm) Radius.....	34
18	Acceptable Dot Size Range Using 120° Stylus with 0.01-in. (0.25 mm) Radius .....	35

**APPROVED FOR PUBLIC RELEASE – DISTRIBUTION IS UNLIMITED**

## NASA-HDBK-6003C

### LIST OF FIGURES, continued

<b>Figure</b>	<b>Title</b>	<b>Page</b>
19	Dot Size Tolerance.....	36
20	Proper Dot Peen Spacing .....	37
21	Examples of Dot Peen Spacing.....	37
22	Row and Column Misalignment .....	38
23	Improper Dot Marking Conditions .....	39
24	Center Offset Marking Error and Overlapping Data Cells .....	39
25	Marking Error with Overlapping Data Cells .....	39
26	Dot Peen Marking With and Without Proper Illumination.....	40
27	Cloth Label Produced Using Fabric-weaving Technique.....	44
28	Laser Light Wavelengths .....	45
29	2-D Markings Applied to the Head of a Straight Pin Using an Ar-F Excimer Laser .....	46
30	Marking Applied to a Surface Using the Laser Coloration Process .....	48
31	Laser Etching Applied Directly to a Surface (A) and to Surface Coating (B) .....	49
32	Laser Engraving Applied Directly to a Surface (left) and to a Surface Coating (right).....	50
33	Magnified Image of Laser Shot-Peen Marking .....	52
34	LISI Marking Applied Directly to a Part Surface (left ) and Applied to a LISI Patch (right) .....	53
35	Scanning Electron Microscope View of the LISI.....	53
36	View of Gas-assisted Laser Etch Coating Under Magnification.....	54
37	Stainless Steel Marking Applied to Glass Slide Using LIVD Process .....	55

### LIST OF TABLES

<b>Table</b>	<b>Title</b>	<b>Page</b>
1	Dot Depth for Stylus Radius. 0.15 mm (0.0059 in.).....	33
2	Dot Depth for Stylus Radius. 0.08 mm (0.0031 in.).....	33
3	Dot Depth for Stylus Radius. 0.10 mm (0.0039 in.).....	36
4	Laser Marking Process Comparison Table.....	56
5	MISSE Marking Sample Data .....	60

**APPROVED FOR PUBLIC RELEASE – DISTRIBUTION IS UNLIMITED**

## NASA-HDBK-6003C

# APPLICATION OF DATA MATRIX IDENTIFICATION SYMBOLS TO AEROSPACE PARTS USING DIRECT PART MARKING METHODS/TECHNIQUES

## 1. SCOPE

This handbook provides detailed guidance for using permanent direct part marking (DPM) methods and techniques to apply Data Matrix identification symbols safely to products. This handbook addresses symbol structure only as it relates to marking and reading limitations. Technical specifications related to the Data Matrix symbol are found in Automated Identification Manufacturers (AIM) International Incorporated technical specification, International Symbology Specification – Data Matrix. Overall program/project requirements on the use of the Data Matrix symbol, including symbol criteria, marking method selection, surface preparation, and protective coating locations, and readability standards are contained in NASA-STD-6002, Applying Data Matrix Identification Symbols on Aerospace Parts.

### 1.1 Purpose

The purpose of this document is to provide information supplementing NASA Standard 6002 regarding the format of dot matrix codes and means for applying them to surfaces.

### 1.2 Applicability

This handbook is applicable to engineering practices for applying Data Matrix identification symbols to parts used in NASA programs/projects using DPM methods and techniques.

This handbook may be referenced in contract, program, and other Agency documents for guidance. Individual portions of this handbook may be tailored (i.e., modified or deleted) by contract or program specifications to meet specific program/project needs and constraints. Tailoring must be formally documented and approved as part of program/project requirements.

This handbook is to be used in new programs as well as those that are currently in the design phase. Retrofit marking for hardware on existing programs is encouraged where feasible. The portions of this document addressing the application of human-readable identification (HRI) markings do not apply to retrofit marking programs. Materials degradation and hazard analyses are conducted in NASA programs when it is assumed that a single HRI marking is to be applied to each product. The application of an additional Data Matrix marking to these parts should be reviewed to ensure that product integrity is not compromised.

Environmental, health, and safety impacts in processes and materials should be considered in employing identification marking methods and techniques. Alternative "environmentally friendly" materials that contain low/no volatile organic compounds (VOCs) should be considered in determining the appropriate method/technique for marking. VOCs are found in

**APPROVED FOR PUBLIC RELEASE – DISTRIBUTION IS UNLIMITED**

## NASA-HDBK-6003C

many types of ink, such as methyl ethyl ketone, xylene, and toluene, which are principal components in atmospheric reactions that form ozone and other photochemical oxidants. Exposures to VOC-containing materials have health impacts, including eye and respiratory irritation, headache, dizziness, memory impairment, neurotoxicity, and cancer.

## 2. REFERENCE DOCUMENTS

The documents cited in this handbook are listed in this section for reference only.

### 2.1 Government Documents

14-CFR (Parts 1-59)	FAA, DOT
FED-STD-595	Colors Used in Government Procurement (Fan Deck)
MIL-A-8625F	Anodic Coatings For Aluminum and Aluminum Alloys
MIL-STD-130L	Identification Marking of U.S. Military Property
NASA-STD-6002	Applying Data Matrix Identification Symbols on Aerospace Parts

### 2.2 Non-Government Documents

A-A-208	Ink Marking, Stencil, Opaque (Porous and Nonporous Surfaces)
A-A-56032	Ink, Marking, Epoxy Base
AIAG B-4	Component Marking Standard (Data Matrix)
AIM	Automated Identification Manufactures (AIM) International Incorporated technical specification, International Symbology Specification – Data Matrix
AIM USA	Uniform Symbology Specification for Data Matrix
ANSI MH10.8.3M	Material Handling – Unit Loads and Transport Packages – Two-Dimensional Symbols (This is now copyrighted by MHI.)
ASM	ASM Surface Engineering Handbook, Volume 5; available from ASM International, Materials Park, OH 44073-0002
ATA Spec-2000	Chapter 9, Bar Coding
EIA-624	Product Packaging Marking
EIA-706	Component Marking Standard (Data Matrix)
EIA-802	Product Marking Standard
EIA SP-3497	Component Product Marking Standard (Data Matrix)
ISO 15415	Two-dimensional symbol print quality
ISO 16022	Information Technology International Symbology Specification Data Matrix
TT-L-50	Lacquer, Nitrocellulose, Acrylic and Acrylic Butyrate Aerosol (in Pressurized Dispensers)
SAE AMS-2806	Identification Bars, Wire, Mechanical Tubing and Extrusions, Carbon and Alloy Steels and Corrosion
SAE AMS-2807	Identification, Carbon And Low-Alloy Steels, Corrosion And Heat Resistant Steels And Alloys Sheet, Strip, Plate, and Aircraft Tubing

APPROVED FOR PUBLIC RELEASE – DISTRIBUTION IS UNLIMITED

## NASA-HDBK-6003C

SAE AMS-STD-184	Identification Marking of Aluminum, Magnesium, and Titanium
SAE AMS-STD-185	Identification Marking of Copper and Copper Base Alloy Mill Products
SEMI T2-95	Specification for Marking of Wafers with Two-Dimensional Matrix Code Symbol
SEMI T7-0997E	Specification for the Back Surface of Double-Sided Polished Wafers with a Two-Dimensional Matrix Code Symbol
SEMI T8-0698	Specification for Marking of Glass Flat Panel Display Substrates with A Two-Dimensional Matrix Code Symbol
SEMI #2999	Test Method for the Assessment of 2D Data Matrix Direct Mark Quality (Draft Document)
SEMI #2999	Specification for the Assessment of 2D Data Matrix Direct Mark Quality (Draft Document)
UPS S28-1	Identification/Codification Standards (Data Matrix and PDF417)

### 3. ACRONYMS AND DEFINITIONS

#### 3.1 Acronyms

AI/DC	automatic identification and data capture
AC	alternating current
AIA	Aerospace Industries Association
AIAG	Automotive Industry Action Group
AIM	Automatic Identification Manufacturers
AMS	Aerospace Materials Specification
ANSI	The American National Standards Institute (a non-government organization responsible for the coordination of voluntary United States standards)
ASCII	American Standard Code for Information Interchange
ASM	American Society for Metals
ATA	Aircraft Transportation Association
CAD	Computer-aided Design
CAGE code	Commercial and Government Entity code
CCD	Charged Coupled Device
CMOS	complementary metal oxide semiconductor
DC	direct current
DoD	Department of Defense
DOT	Department of Transportation
DPM	Direct Part Marking
ECE	electro-chemical etching
ECM	electro-chemical marking
EDM	Electrical Discharge Machining
EIA	Electronic Industry Association
EVA	Extravehicular Activity

**APPROVED FOR PUBLIC RELEASE – DISTRIBUTION IS UNLIMITED**

## NASA-HDBK-6003C

FAA	Federal Aviation Administration
FED	Federal
FSCAP PAT	Flight Safety Critical Aircraft Part Problem Action Team
GALE	gas-assisted laser etch
HRI	human-readable identification
ISO	International Standards Organization
Laser	Light Amplification by Stimulated Emission of Radiation
LENS	Laser-Engineered Net Shaping
LEO	Low Earth Orbit
LISI	Laser-induced Surface Improvement
LIVD	Laser Induced Vapor Deposition
LMJ	Liquid Metal Jet
MHI	Materials Handling Institute
MIL	Military
MISSE	Materials International Space Station Experiment
NASA	National Aeronautics and Space Administration
NCMS	National Center of Manufacturing Sciences
OVHD	Overhead
PEC	Passive Experiment Container
SAE	Society of Automotive Engineers
SCR	Selective Catalytic Reduction
SDOs	Standards Developing Organizations
SEMI	Semiconductor Equipment and Materials International
STD	Standard
UCC	Uniform Code Council
USCG	United States Coast Guard
UV	Ultraviolet
V	Volt
VOC	Volatile Organic Compounds
WAD	Work Authorization Document

### 3.2 Definitions

2D: Two-dimensional

3D: Three-dimensional

Bar Code: A patterned series of vertical bars of varying widths used by a computerized scanner for inventory, pricing, etc.

Binary Value: A dot in the substrate surface indicates the binary of one. The absence of a dot or a smooth surface surrounding a cell center point indicates the binary value of zero.

**APPROVED FOR PUBLIC RELEASE – DISTRIBUTION IS UNLIMITED**

## NASA-HDBK-6003C

Bit (Binary Digit): The basic unit of information in a binary numbering system; 1s and 0s are used in a binary system.

Border Column: The outermost column of a data matrix code; the column is a portion of the finder pattern.

Border Row: The outermost row of a data matrix code; this row is a portion of the finder pattern.

Cell Center Point of an Array: The point at which the center line of a row intersects the centerline of a column.

Cell of a Data Matrix Symbol: The area within which a mark may be placed to indicate a binary value; the cell is the smallest element of a two-dimensional matrix symbol.

Cell Spacing of an Array: The (equal) vertical or horizontal distance between the cell center points of contiguous cells.

Center Line of a Row or Column: The line positioned parallel to, and spaced equally between, the boundary lines of the row or column.

Central Area of a Cell: The area enclosed by a circle at the center point; used by code readers to sense the binary value of the cell.

Character (Data Character): A letter, digit, or other American Standard Code for Information Exchange (ASCII) symbol.

Character Set: That character available for encodation in an automated identification technology.

cm: Centimeter

CO<sub>2</sub>: Carbon Dioxide

Components: Relates to parts used in the manufacture of launch vehicles, satellites, aircraft, and supporting hardware (e.g., facilities, ground support equipment, mission kits, test devices, etc.).

Contrast: Grayscale difference between two areas of color.

Data Matrix Code Symbol: A two-dimensional array of square cells arranged in contiguous rows and columns. In certain electro-chemical etching ECC 200 symbols, data regions are separated by alignment patterns. The data region is surrounded by a finder pattern (AIM – Data Matrix).

**APPROVED FOR PUBLIC RELEASE – DISTRIBUTION IS UNLIMITED**

## NASA-HDBK-6003C

Data Redundancy: Data repeated in a code to correct possible errors caused by damage, poor print quality, or erasures.

Density (Matrix Density): The number of rows and columns in a scanned matrix symbol.

Depth of Etch: The distance from the surface of the substrate to the bottom of the recess created by an etching process.

Depth of Field: Minimum and maximum range (distance) an object stays in focus without lens adjustment.

Dot: A localized region with a reflectance which differs from that of the surrounding surface.

Dot Misalignment Within a Cell: The distance between the physical center point of a dot and the cell center point.

Edge: A dramatic change in pixel brightness values between regions; the point(s) that has the greatest amount of contrast (change in intensity values) between pixels.

Electrolyte: The solution formed by water and a selected salt(s), and used as the conductor between an object and electrode in an electro-chemical marking process. Selected electrolytes also have the ability to “color” the mark due to the chemical reaction that occurs between the metal and the electrolyte.

Error Correction: Mathematical technique that reconstructs the original information based on the data in a damaged or poorly printed code. Reed Solomon and convolution are two such techniques.

F: Fahrenheit

Fatigue: The cumulative irreversible damage incurred in materials caused by cyclic application of stresses and environments resulting in degradation of load-carrying capability.

Field of View: The maximum area that can be viewed through the camera lens or on the monitor.

Finder Pattern of a Data Matrix Code Symbol: A perimeter to the data region. Two adjacent sides contain dots in every cell which are used primarily to define physical size, orientation, and symbol distortion. The two opposite sides are composed of cells containing dots in alternate cells (AIM – Data Matrix).

Focal Length: The distance from the main lens to the back focal point projected on the charge coupled device (CCD) array.

**APPROVED FOR PUBLIC RELEASE – DISTRIBUTION IS UNLIMITED**

## NASA-HDBK-6003C

Grayscale: The assignment of a digital value to a degree of light intensity. The shades of gray are used by the computer to reconstruct an image. A common scale is 256 shades of gray, with 0 being black and 255 being white.

Hardness: A measure of the resistance of a material to surface indentation or abrasion; a function of the stress needed to produce surface deformation. There is no absolute scale for hardness; therefore, to express hardness quantitatively, each type of test has its own scale of arbitrarily defined hardness. Indentation hardness can be measured by Brinell, Rockwell, Vickers, Knoop, and Scleroscope hardness tests.

Human-Readable Identification: The letters, digits, or other characters associated with symbol characters incorporated into the linear bar code or two-dimensional symbols.

Intensity: The average of the total of grayscale values.

Intrusive Marking: Any device designed to alter a material surface to form a human- or machine-readable symbol. This marking category includes, but is not limited to, devices that abrade, burn, corrode, cut, deform, dissolve, etch, melt, oxidize, or vaporize a material surface.

J: Joule

kHz: Kilohertz (1000 cycles of oscillation per second)

Laser – Long Wave Length: Lasers operating in the 750-10,000 nm range.

Laser – Short Wave Length: Lasers operating in the 1 to 399 nm range.

Laser – Visible Spectrum: Lasers operating in the 400-749 nm range.

License Tag Number: The information contained with the symbol character set to uniquely identify the component.

Manufacturer: Producer or fabricator of a component, or the supplier if the warrantor of the component.

Mark: Data matrix symbol that has been applied to a material surface using a permanent marking method.

Matrix: A set of numbers, terms, or items arranged in rows and columns.

Matrix Density: the number of rows and columns in a matrix.

mm: Millimeter

Nd:YAG: Neodymium Yttrium Aluminum Garnet crystal

**APPROVED FOR PUBLIC RELEASE – DISTRIBUTION IS UNLIMITED**

## NASA-HDBK-6003C

Nd:YAP: Neodymium doped Yttrium Aluminum Perovskite crystal

Nd:YLF: Neodymium doped: Yttrium Lithium Fluoride crystal

Nd:YVO<sub>4</sub>: Neodymium-doped yttrium vanadate orthovanadate crystal

Non-Intrusive Marking: A method of marking by adding material to a surface. Non-intrusive marking methods include ink jet, laser bonding, liquid-metal jet, silk screen, stencil, and thin-film deposition.

ns: nanosecond

Overhead (OVHD) Characters: Characters within a symbol that are not data characters, e.g., start, stop, error checking, concatenation, and field-identifier characters.

Permanent Marking: Designed to remain legible throughout the normal service life of an item.

Photo-Stencil: A silk-screen fabric coated with a photo-resistant compound which can be fixed by ultraviolet (UV) radiation and easily washed from the fabric where unexposed. The patterns opened in the fabric are the images to be marked (stenciled, etched, or colored) on the substrate.

Pixels: Picture elements. In a camera array, pixels are photoelectric elements capable of converting light into an electrical charge.

psi: Pounds per square inch

Quiet Zone: Areas of high reflectance (spaces) surrounding the machine-readable symbol; sometimes called "Clear Area" or "Margin." Quiet-zone requirements are found in application and symbology specifications.

Reader: Another name for a CCD or complementary metal oxide semiconductor (CMOS) camera configured to read symbols.

Redundant Data: Data that is repeated in a code. This data is randomly placed or encoded inside the data storage area to increase a symbol's ability to recover from damage.

Reference Point of a Data Matrix Symbol: The center point of a cell common to a designated row and column, used to identify the location of the symbol on the object being marked.

**APPROVED FOR PUBLIC RELEASE – DISTRIBUTION IS UNLIMITED**

## NASA-HDBK-6003C

**NOTE:** The reference point is a fixed location on the object; different cells may be chosen as the reference point depending on the desired orientation of the symbol. The cell to be used as the reference point needs to be specified for each application.

Resolution: How small the camera can distinguish an object in its field of view. Camera resolution is determined in its field of view. The number of pixels within the CCD array determines camera resolution. The more pixels used to capture the image, the higher the resolution or quality of the image. Since the number of pixels is fixed, the smaller the field of view, the higher the image resolution. For example, a 1 inch (25.4 mm) field of view photographed by a 640 x 480 pixels camera has a resolution of 0.002 inch (0.04 mm) per pixel; a ½ inch (12.7 mm) field of view yields a resolution of 0.0008 inch (0.02 mm) per pixel.

Scaleable Code: A matrix code where the presence or absence of a cell is all that is needed. The code can be made any size since non-measurements are being made, unlike a bar code, which is decoded by measuring the width of each element.

Structure: The order of data elements in a message.

Substrate: The material (paper, plastic, metal, etc.) upon which a symbol is marked.

Supplier: The trading partner in a transaction that provides the component (e.g., manufacturer, distributor, reseller, etc.).

Symbology: A machine-readable pattern composed of a quiet zone, finder pattern, and symbol characters that include special functions and error detection and/or correction characters needed by a particular symbology.

Thermal Stencil: Similar to the photo-stencil. In this case, the fabric is coated with a compound that can be opened by a thermal printer to form the desired images.

Weld Cleaner: A device using electro-chemical processes to remove oxidation marks.

## 4. GUIDANCE

### 4.1 Part Tracking System Advancements

Parts, components, assemblies, and contract end items used on NASA programs/projects are marked with letters and numbers to trace the items to their respective manufacturing and operational histories. This data is reviewed to ensure that products are properly configured to support mission objectives. The successful operation of NASA's part tracking systems is critical to mission safety.

In the past, these systems utilized hard-copy Work Authorization Documents (WADs) that were routed to computer input stations after closure and inspection buy-off. Personnel at these stations reviewed the WADs for completion and then manually transposed the product status into

**APPROVED FOR PUBLIC RELEASE – DISTRIBUTION IS UNLIMITED**

## NASA-HDBK-6003C

the appropriate configuration management and quality assurance database(s). Due to the nature of this process, product status in the database(s) could be behind actual conditions by days or even longer. Data variances detected by the computer programs were investigated and then corrected after the fact. Variances utilized limited resources and increased program costs.

These conditions, inherent in paper-based systems, were tolerated by program officials, who often made critical decisions based on incomplete and incorrect data. Part identification technology has now matured so that accurate product information can be electronically moved between the shop floor and the program's databases. This has been made possible by the development of a machine-readable code, known as the Data Matrix symbol. This symbol was designed to be applied directly to, and read from, parts made from a wide range of materials. The following sections of this handbook were developed to provide users with the methods and information necessary to safely apply these symbols to NASA hardware.

### 4.2 Marking Methods

DPM is generally suggested in applications where

- Traceability is needed after the product is separated from its temporary identification
- The part is too small to be marked with bar code labels or tags
- The part is subjected to environmental conditions that preclude the use of add-on identification data
- Identification is needed beyond the expended life of the part to preclude further use

DPM can be divided into two primary categories: non-intrusive and intrusive.

#### 4.2.1 Non-Intrusive Marking Methods

Non-intrusive markings, also known as additive markings, are produced as part of the manufacturing process or by adding a layer of media to the surface. Non-intrusive markings use methods that have no adverse effect on materials. These methods include the following:

- Automated adhesive dispensing
- Investment casting
- Sand casting
- Ink jet
- Laser bonding
- Laser engineered net shaping (LENS)
- Silk screen
- Stencil

See the following for details on these methods.

**APPROVED FOR PUBLIC RELEASE – DISTRIBUTION IS UNLIMITED**

## NASA-HDBK-6003C

### 4.2.1.1 Automated Adhesive Dispensing

Automated adhesive dispensing systems are designed to deposit precise amounts of adhesive on a repeatable basis. The preferred system employs an overhead gantry that allows for accurate positioning of the dispensing heads while the object remains stationary. Any fluid application is possible, including fully contoured beads, dot dispensing, gasketing, potting, and spraying of one- and two-part materials.

For maximum accuracy and dependability, specified systems should allow for three-axis movement, driven by Teflon-coated stainless steel lead screws and controlled by 5-phase stepper motors and precision servomotors. These drive systems ensure a resolution of +/-0.001 inch (0.03 mm).

The system specified should be supported by a Windows platform incorporating Windows graphical and icon-driven concepts to provide a user-friendly environment. Pull-down menus should allow operators to quickly input their dispensing parameters, and on-screen displays should allow for real-time monitoring and control of the dispensing sequence. Software should allow for circular path motion in XY, XZ, and YZ combinations, which provides continuous dispensing at different levels and shapes including vertical peaks and valleys (contouring).

The system specified should be designed to incorporate a full spectrum of dispensing heads from syringes to fully integrated valves and controllers. Special consideration should be given to dispensing heads that are field repairable with a minimum of downtime. Such systems contain disposable material path inserts that allow the valve to be replaced on line and with no cleaning.

Clean marking surfaces are needed prior to marking.

### 4.2.1.2 Investment Casting

Investment cast metal marking of the 2-D (two-dimensional) Data Matrix identification symbol is achieved by printing a pattern of the symbol in physical or 3-D form on a printer such as the ThermoJet Solid Object printer. These printers produce objects by using an ink-jet print head that uses a wax-based thermoplastic material instead of ink, and prints layer upon layer to build up the "ink" thickness to a 3-D object. For cast metal marking, the 3-D pattern of the Data Matrix symbol is incorporated into a coupon made from the wax-based thermoplastic material. Once printed, this coupon can be turned into a cast metal equivalent by putting the wax coupon pattern through investment casting.

For direct-part marking of investment cast parts, these wax coupons are directly attached to the wax pattern of the part before the investment-casting process is begun. For parts that are fabricated using sand casting, the wax coupons containing the Data Matrix symbology would be placed into a recess in the mold pattern before the sand mold is compacted and formed. For parts produced by the molding or forged fabrication processes, the wax coupons containing the Data Matrix symbology would be investment-cast first to produce a cast metal coupon which would be inserted into a recess in the mold before the part is fabricated.

**APPROVED FOR PUBLIC RELEASE – DISTRIBUTION IS UNLIMITED**

## NASA-HDBK-6003C

The maximum size of a 3-D printed Data Matrix symbol is primarily limited by the maximum readable size of the scanning device (typically 2 in. [50.8 mm] to 3 in. [76.2 mm]), and to a lesser extent, by the build platform size (typically 8 in. [203.2 mm] by 10 in. [254 mm]) of the 3-D printing device. The cells of the Data Matrix symbol are either raised above the surface or recessed into the coupon, and when side-lit, produce the contrast pattern to be read by a Data Matrix scanner. Individual cell X, Y dimensions are typically above 0.015 in. (0.38 mm) to 0.02-in. (0.51 mm) for good acuity and readability after the investment casting. Any geometry may be used for the cell profile within limits of the printing resolution of the 3-D printer, typically 300-400 dpi. The preferred cell profiles are semi-spherical, conical, or pyramidal. The conical or pyramidal profile can also be truncated to help eliminate sharp corners and corresponding stress risers. The depth or height of a cell recess or protrusion can be as little as 0.002 in., (0.04 mm) and is primarily limited by scanning constraints. This 0.002 in. (0.04 mm) dimension is a typical single-layer thickness for 3-D printing. The maximum height or depth of a cell is only limited by the constraints of reproducing high-aspect ratio features in the investment-casting process, and by the coupon or part thickness itself. Typically, aspect ratios (depth/dimension) of less than 1 are preferred for investment casting.

A preferred pyramid profile used to produce a raised cell is shown in cross-section in figure 1. The protruding profile is preferable, because it is less likely to trap or attach fluid within or around the cells during face coating in investment casting. The sloped faces of this profile reflect the light away from the scanner receptor, decreasing the contrast for the cell. This enables the scanner to distinguish the contrast of this cell from the neighboring cells on the exposed surface of the coupon.

Cells should be placed as close together as the marking method allows without overlapping (see figure 2).

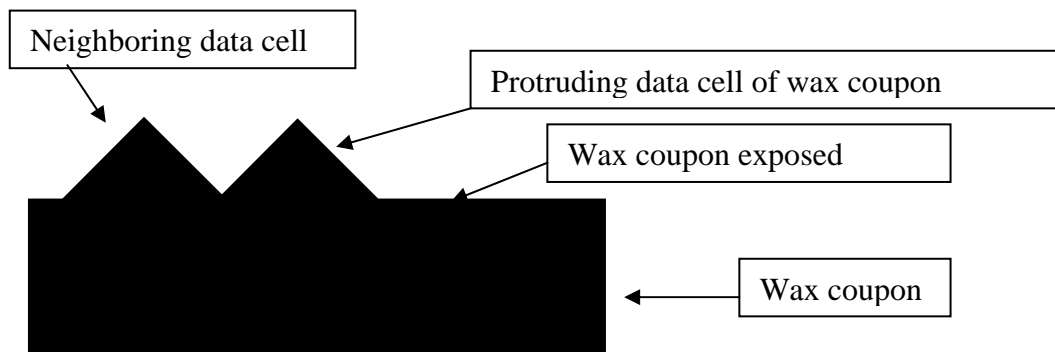
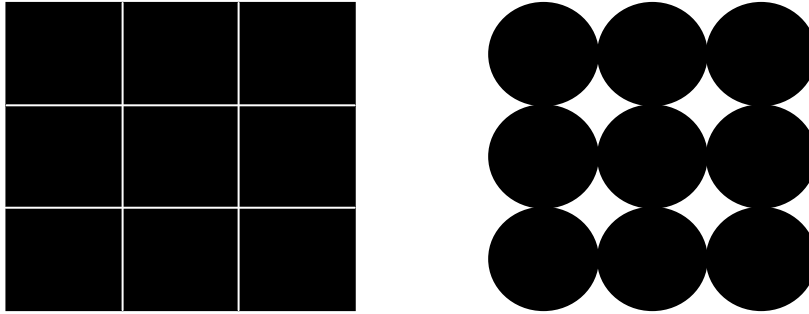

Figure 1—Preferred Mold Profile

## NASA-HDBK-6003C



**Figure 2—Preferred Cell Spacing**

Limitations of investment casting are as follows:

- Raised cell profiles are preferred for end-use parts subjected to high stresses.
- Raised cell profiles are preferred for accurate reproduction in investment casting, making it less likely to trap fluid bubbles.
- Raised cell profiles with truncated vertices are preferred for end-use parts subjected to high stresses.
- Raised markings should not be used if interference with manufacturing operations or other mating parts in the end use is anticipated.
- Markings should be used on non-machined surfaces only.
- Coupon overall thickness less than 0.02 in. (0.51 mm) may be difficult to handle in manufacturing operations, such as attachment to wax pattern.
- Cell profiles with aspect ratios substantially greater than 1 may be difficult to produce using investment casting.

### 4.2.1.3 Sand Casting

Sand casting produces robust raised markings that survive within the most hostile manufacturing, operational, and overhaul processes. The process can be adapted to apply Data Matrix symbols using an Yttrium Aluminum Garnet (Nd:YAG) laser configured for deep-laser engraving to cut a symbol directly into the sand-cast mold. The laser program can be adjusted to produce symbols of varying sizes and to any depth needed. It can also cut data cells with shapes (cone or pyramid) that reflect light away from the reader lens, creating the contrast needed for successful reading (see figures 3, 4, and 5).

**APPROVED FOR PUBLIC RELEASE – DISTRIBUTION IS UNLIMITED**

NASA-HDBK-6003C

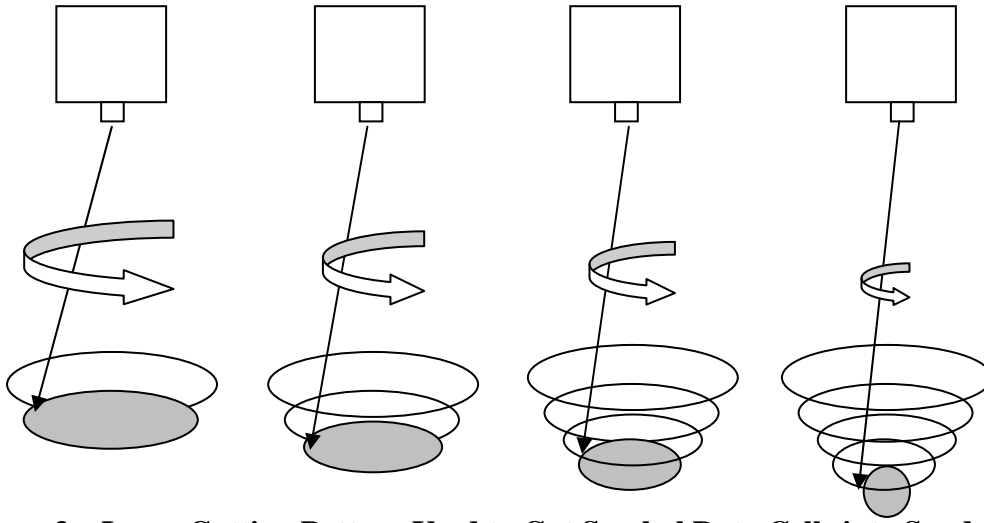

Figure 3—Laser Cutting Pattern Used to Cut Symbol Data Cells into Sand-Cast Mold

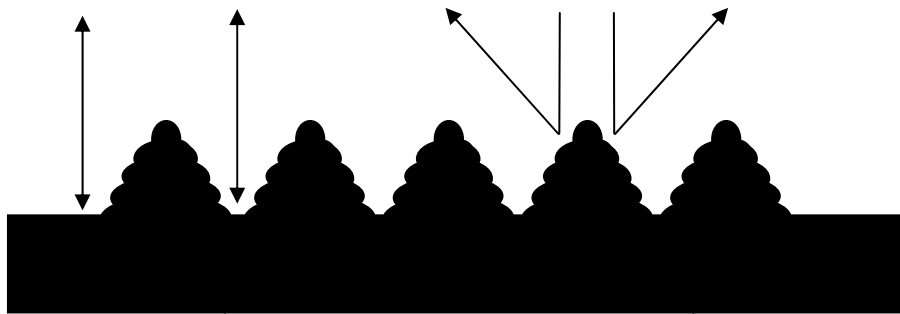
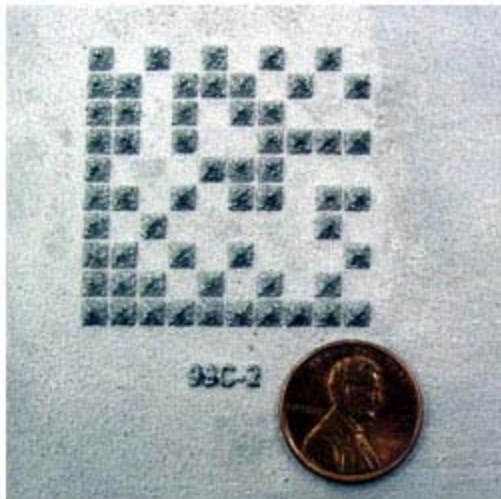

Figure 4—Cross Section of Sand-Cast Symbol Designed to Provide Artificial Contrast for Successful Decoding

APPROVED FOR PUBLIC RELEASE – DISTRIBUTION IS UNLIMITED

## NASA-HDBK-6003C



**Figure 5—Photograph of Sand-Cast Marking**

Sand casting limitations are as follows:

- Raised markings should not be used if interference with manufacturing operations or other mating parts in the operation is anticipated.
- Markings should be used on non-machined surfaces only.
- The process is generally limited to flat or slightly curved surfaces.

#### 4.2.1.4 Ink Jet

Ink-jet markers propel ink globules from the printing head to the part surface. The permanence of the mark depends on the chemical interaction of the ink, surface of the part, and other materials to which the part may be exposed, e.g., cleaning solvents. Care is needed to ensure that the chemical properties of the ink used are compatible with the material being marked and with the processes through which the part would be exposed. When applied to metal parts, ink-jet markings should be coated with a clear lacquer in accordance with TT-L-50 before oiling.

Operators should evaluate a test mark to identify and correct any problems such as the following:

- Symbol distortion
- “Doughnutting”
- Ink splatter
- Smearing

These conditions can be corrected if the gap is adjusted between the print head and the target, the shaft encoder input (speed sensor), system air pressure, and the ink formulation. Figure 6 illustrates examples of ink-jet marking that adversely affect reading.

**APPROVED FOR PUBLIC RELEASE – DISTRIBUTION IS UNLIMITED**

## NASA-HDBK-6003C

Ink-jet markers should not be applied to parts subjected to the following:

- Immersion in liquids
- Prolonged exposure to liquid splash or spray
- High temperatures
- Abrasion, rubbing, or sliding wear

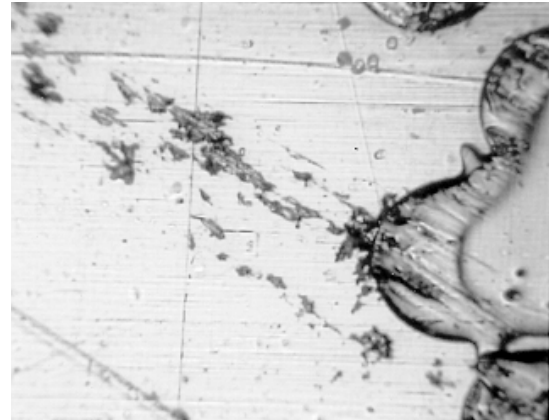
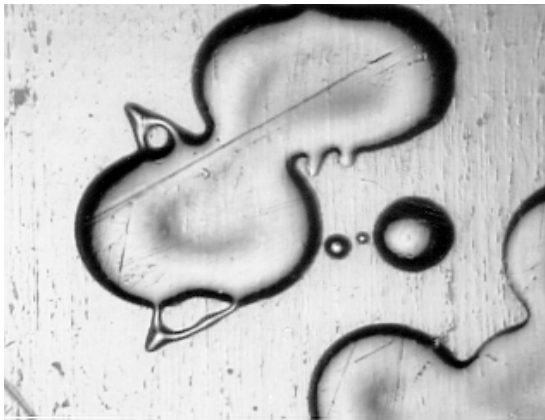
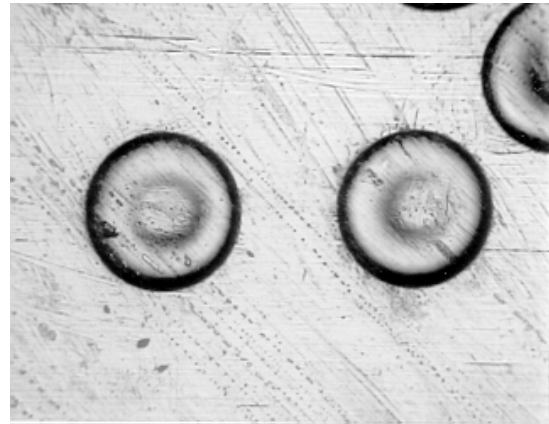
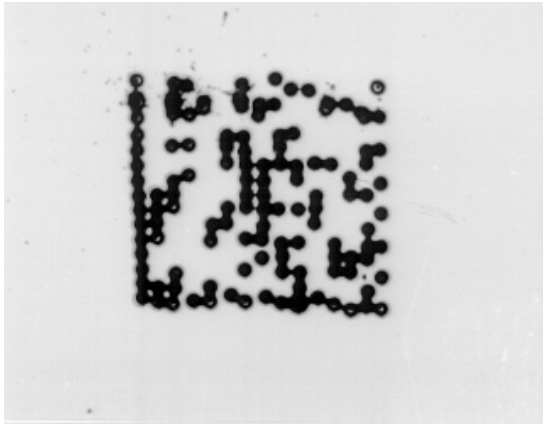

**Figure 6—Unacceptable Ink-jet Markings**

The minimum size of the Data Matrix is 0.38-in. (9.53 mm) square, with a density (number of rows and columns) of 16x16 cells, representing 16 alphanumeric characters. Ultraviolet (UV) ink can be used for security or aesthetic purposes.

### 4.2.1.5 Laser Bonding

Laser bonding is an additive process that involves the bonding of a material to the substrate surface using the heat generated by an Nd:YAG, Nd:YVO<sub>4</sub>, or carbon dioxide (CO<sub>2</sub>) laser. The materials used in this process are commercially available, and generally consist of a glass-frit

**APPROVED FOR PUBLIC RELEASE – DISTRIBUTION IS UNLIMITED**

## NASA-HDBK-6003C

powder or ground metal, oxides mixed with inorganic pigment, and a liquid carrier (usually water). The pigment can be painted or sprayed onto the surface to be marked, or transferred via pad printer, screen printer, or coating roller. Adhesive-backed tapes coated with an additive are also used in this process.

Laser bonding can also be performed using a CO<sub>2</sub> laser and ink foils for less harsh environments. This process is accomplished using heat levels that have no noticeable effect on metal or glass

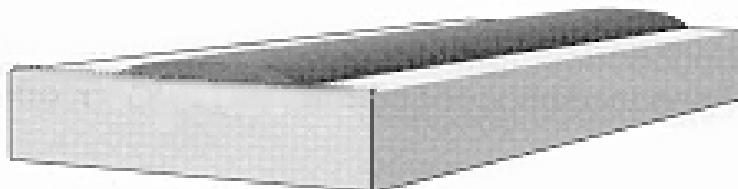

substrates and are safe for use in safety-critical applications. The markings produced using this technique (dependent on the material used), are resistant to high heat, unaffected by salt fog/spray, and extremely durable (see figure 7).

**Figure 7—Material Fused to a Surface Using the Laser Bonding Process**

In laser bonding, the following steps are necessary:

- Establish laser-bonding parameters using scrap material or test coupons of the same material as the product to be marked.
- Stir and agitate coating materials vigorously to ensure that the bonding materials are in suspension.
- Apply coatings in a manner that ensures even distribution across the marking surface.
- Test the settings established for laser bonding on bare metal to ensure that the heat levels applied produce no visible effect on the part surface.

Figure 8 illustrates some of the more common laser-bonding markings that adversely affect reading.

**APPROVED FOR PUBLIC RELEASE – DISTRIBUTION IS UNLIMITED**

NASA-HDBK-6003C

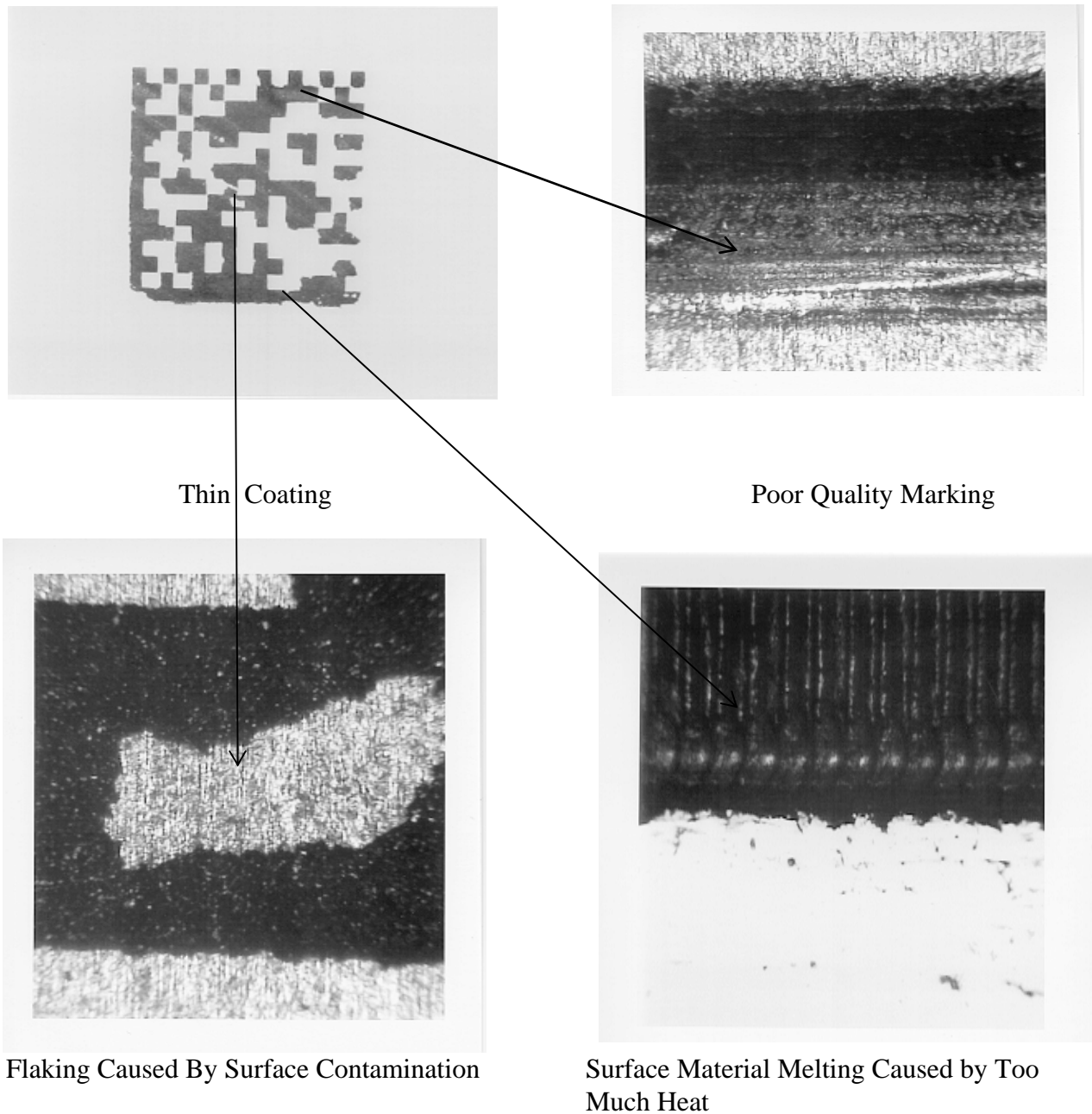

**Figure 8—Unacceptable Laser Bonding Markings**

Limitations of laser bonding are as follows:

- Coatings are application-specific.
- The process is generally limited to flat or slightly curved surfaces.
- Laser bonding is restricted to materials thicker than 0.001 in. (0.025 mm).
- The process cannot be applied to painted surfaces.

**APPROVED FOR PUBLIC RELEASE – DISTRIBUTION IS UNLIMITED**

## NASA-HDBK-6003C

### 4.2.1.6 LENS

LENS utilizes heat from an Nd: YAG laser to form a small weld pool on the surface to be marked. Simultaneously, metallic powder is injected into the molten pool, as shown in figure 9. 3-D computer-aided design (CAD) software is used to manipulate the head or the part to deposit the Data Matrix symbol. The injected metallic material does not need to be the same as the part, and can be selected to be corrosion-resistant or wear-resistant, or for any other desirable characteristic. LENS-deposited materials offer a rough surface finish, providing good light reflection. This process is compatible with all common steels, titanium, aluminum, nickel, and copper alloys. LENS provides a small heat-affected zone in the part. LENS markings can be resistant to abrasion and chemical reactions. These markings protrude above a surface since this process adds material to an existing substrate (see figure 10).

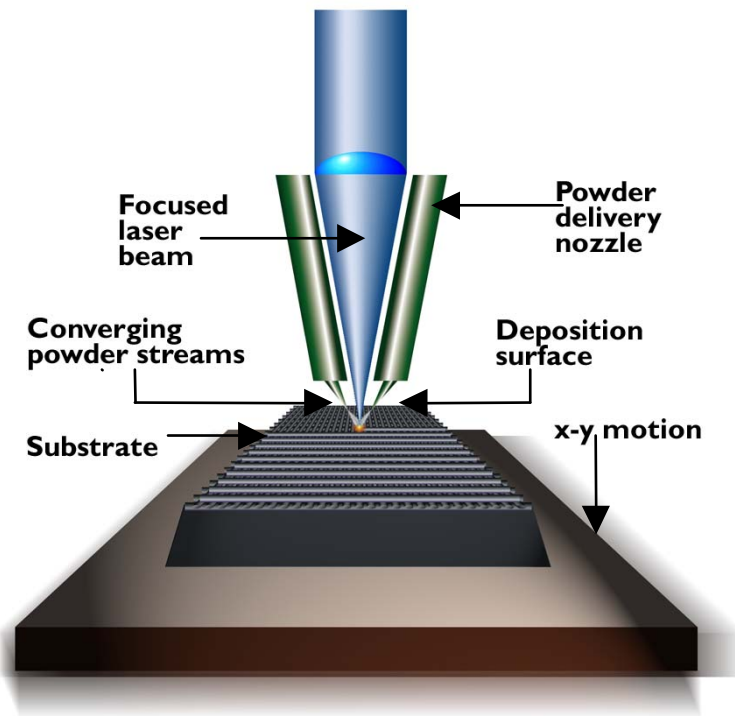
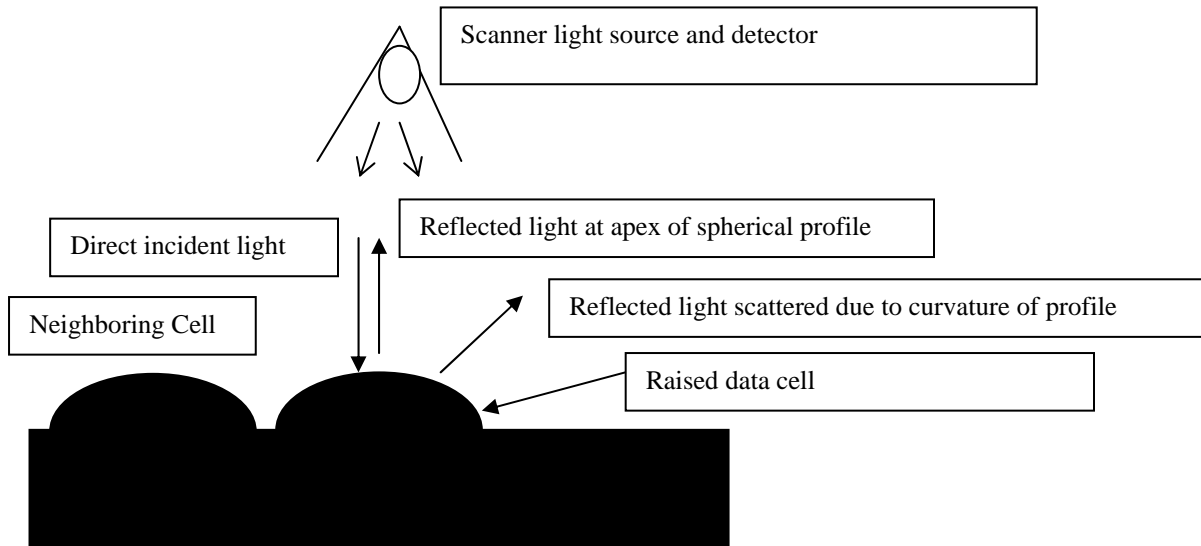

Figure 9—Schematic Illustration of the LENS Process

APPROVED FOR PUBLIC RELEASE – DISTRIBUTION IS UNLIMITED

**NASA-HDBK-6003C**



**Figure 10—Spherical Mold Profile**

The scanned image of this profile results in the contrast map as shown below in figure 11.

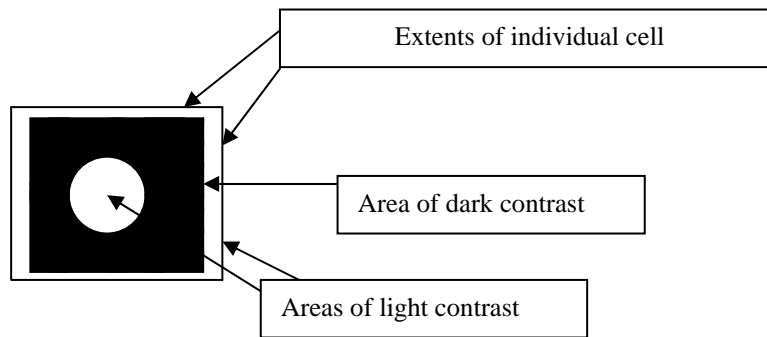

**Figure 11—Camera Image of Spherical Profile**

Figure 12 demonstrates the contrast of a cell reduced because of the bright spot in the center, which is caused by the spherical profile surface near the center's having a relatively flat slope. This effect is more pronounced for cubical cell profiles.

When a spherical or cubical profile is used, the frame or border dimension needs to be at least 0.004 in. (0.09 mm) in width completely surrounding an individual cell profile. This reduces the cell profile feature size by the same dimension. For example, for a minimum cell size of 0.03 in. (0.60 mm), the cell profile feature size is reduced to a dimension of 0.02 inch (0.46 mm).

LENS is limited to metallic alloys.

**APPROVED FOR PUBLIC RELEASE – DISTRIBUTION IS UNLIMITED**

## NASA-HDBK-6003C

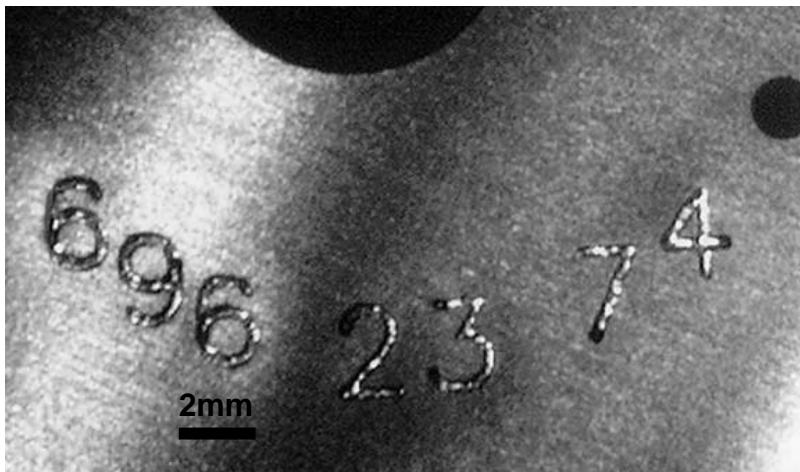

**Figure 12—Direct Part Marking Using LENS (A Molybdenum Disk Marked With Stainless-Steel Raised Lettering)**

### 4.2.1.7 Silk Screen

Silk-screen markings are applied by pressing a pigmented marking media (usually ink or paint) through openings in a mask. In the past, silk-screen marking masks were made from woven silk or nylon fabrics coated with a photo-sensitive resistant material. The symbol is created by placing a photo negative over the stencil and exposing it to an ultraviolet light source. The unexposed areas of the stencil are then dissolved using a chemical cutter, exposing openings in the mask for marking. The most common problems experienced using this silk-screen generation method are poor marking edge definition caused by improper light exposure times and marking voids caused by incomplete chemical cleaning of the stencil mask. The silk-screen stencil process was recently automated so that Data Matrix symbols can be printed similarly to printed labels. The new method involves using a special laminated masking material that is passed through a desktop printer. The printer then perforates a thermoplastic resin coating using a thermal print head to form an opening for silk screening and electrochemical etching.

Silk screen should not be used on the following:

- Items exposed to liquid spray or splash
- Items exposed to high temperatures (more than 300°F)
- Items exposed to rubbing wear or abrasion

**APPROVED FOR PUBLIC RELEASE – DISTRIBUTION IS UNLIMITED**

## NASA-HDBK-6003C

### 4.2.1.8 Stencil

Stencil markings are applied by depositing a marking agent onto a surface using a mask that has openings corresponding to the shape of the desired marking. Stencils are generated using photo process, laser-etching, or mechanical micro-cutting processes. Laser etched and mechanically cut stencils need a symbol pattern that provides spacing between the data cells to keep the pattern together. The spacing provides a grid of interconnecting data cell elements that typically occupies approximately 36 percent of the individual data cell marking area, as illustrated on figure 13. Interconnecting data cell elements that occupy less than 26 percent of the allotted data cell marking space can be damaged during stencil generation and handling, and those exceeding 46 percent of the allotted data cell area can adversely affect symbol readability.

Stencils can be created from a wide range of application-dependent materials including paper, vinyl, zinc, aluminum, polypropylene, or magnetic rubber. Adhesive-backed stencils are used with marking agents that bleed under the stencil surface. Marking agents are applied to the part surface by spraying, rolling, or dabbing the agent through the openings in the mask. The marking agents most commonly used with stencil marking include the following:

- Abrasive blast
- Acid etch
- Chemical coloring agents
- Dip, barrier, and chemical conversion coatings
- Plating and Electro-Plating
- Ink (refer to A-A-208 and A-A-56032)
- Vacuum and controlled atmosphere coatings, and surface modification processes

The limitations of stencils include the following:

- Stencil marking processes are impractical for use with irregular-shaped surfaces (compound curves).
- Some marking agents are susceptible to damage caused by abrasion, rubbing wear, and exposure to high temperatures.
- Some marking agents may be susceptible to damage caused by immersion in liquids or prolonged exposure to liquid splash or spray.

**APPROVED FOR PUBLIC RELEASE – DISTRIBUTION IS UNLIMITED**

**NASA-HDBK-6003C**

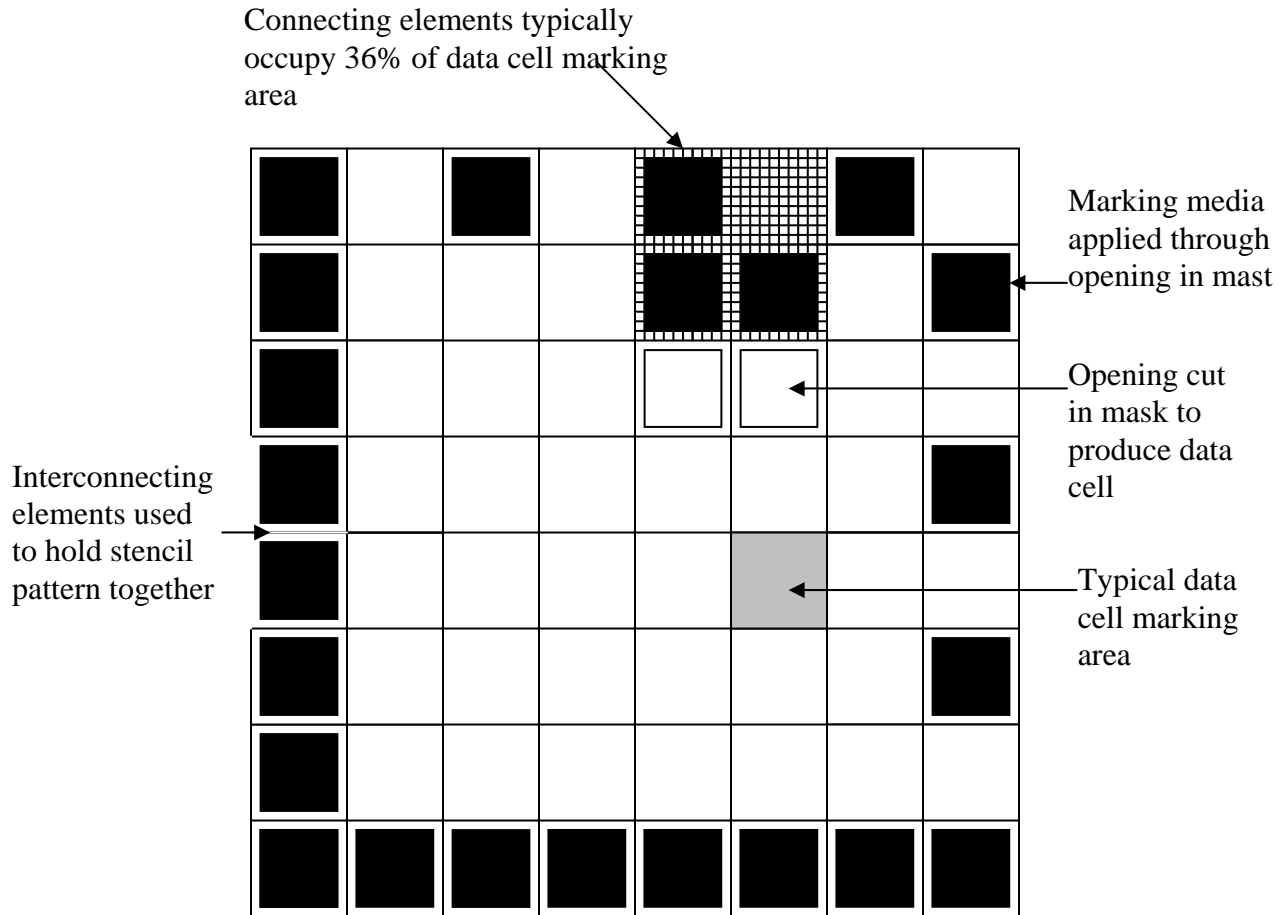

**Figure 13—Data Matrix System Stencil Structure**

4.2.2 Intrusive Marking Methods

Intrusive markings alter the part surface (abrade, cut, burn, vaporize, etc.) and are considered to be controlled defects. If not performed properly, the markings can degrade material properties. Consequently, some intrusive markings, especially laser, are generally not used in safety-critical applications without appropriate metallurgical testing. Typical intrusive marking methods include the following:

- Abrasive blast
- Dot peen
- Electro-chemical marking
- Engraving/milling
- Fabric embroidery/weaving
- Direct laser marking

**APPROVED FOR PUBLIC RELEASE – DISTRIBUTION IS UNLIMITED**

## NASA-HDBK-6003C

### 4.2.2.1 Abrasive Blast

The micro-abrasive blast marking system operates by directing a mixture of dry air and abrasive (silica, baking soda, etc.) through a small tungsten carbide nozzle at high velocity. To provide the requested mark, software automatically controls the direction and speed of the nozzle, the length of the stop-and-go pulses, and the flow pressure. Marking quality is controlled by abrasive type, air pressure, nozzle speed, and gap (nozzle-to-target distance). Abrasive blasting is commonly utilized on texture surfaces prior to marking to reduce glare.

Abrasive blast limitations are as follows:

- Cannot be used in humid conditions
- Cannot be used to mark irregular-shaped surfaces
- Should not be used where particle contamination is an issue
- Should ensure that there are no corrosion or compatibility issues between the grit and the marking surface

### 4.2.2.2 Dot Peen (Stamp Impression)

Dot peening is achieved by striking a carbide or diamond-tipped marker stylus against the surface of the material being marked. Symbol size is controlled by the size and tip angle of the stylus, by dot spacing, or by altering the number of strikes per data cell. Single strikes are used to create small symbols. Multiple strikes can be used to create larger symbols. An odd number of strikes is recommended to create data cells to ensure that a recess is located in the center of each data cell (e.g., 3x3, 5x5, 7x7, etc.). See figure 14.

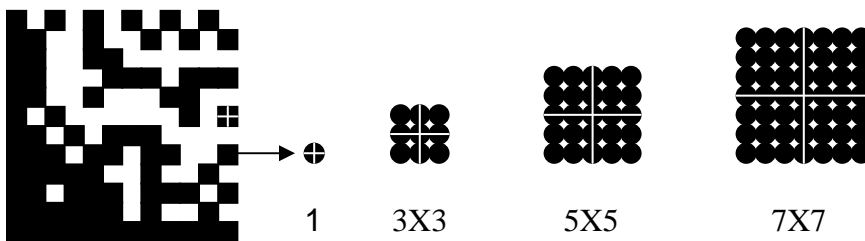

Odd number data patterns recommended for improved

**Figure 14—Dot-peen Patterns Used to Create Individual Data Cells**

The depth for stamp impression marking is typically 0.003 in.  $\pm 0.001$  in. (0.08  $\pm 0.03$  mm) (application dependent). Exact depths can be controlled by adjusting system air pressure or force, and the gap between the stylus and the target. Dot-peen markings less than 0.002 in. (0.051 mm) deep can cause difficult reading when applied to surfaces with an average peak-to-valley roughness of more than 32 micro-in. (0.001 mm).

**APPROVED FOR PUBLIC RELEASE – DISTRIBUTION IS UNLIMITED**

## NASA-HDBK-6003C

The marking force needs to be consistent due to the small dot size. Marking machines with an electro-magnetic system are consistent; however, marking machines with air-pressure systems often have problems with pressure variation of the air supply system. A variation of 15 psi for an air supply system is not unusual. For DPM and the desired dot size, the air pressure should be adjusted within  $\pm 2.5$  psi. The amount of force required depends on the mass of the stylus, the hardness of the target material, and the depth desired.

Single-pin markers are preferred for use in the aerospace industry. Hand-held markers are acceptable, but are necessarily clamped to the surface to prevent unwanted movement during marking.

Machine setup operations are necessarily checked to ensure that the stylus (pin) is positioned at a  $90^\circ$  angle (perpendicular) to the marking surface. Pin projection from the stylus nose guide should not exceed 0.5 in. (12.7 mm) in the retracted state to prevent deflection upon impact and its resulting oscillations.

Dot depth is dependent on the distance between the tip of the retracted stylus and the target surface. This distance is variable and ranges from 0.05 in. (1.27 mm) to 0.5 in. (12.7 mm). The greater the distance between the stylus tip and the surface, the deeper the dot will be. Refer to figure 15 for proper pin adjustments.

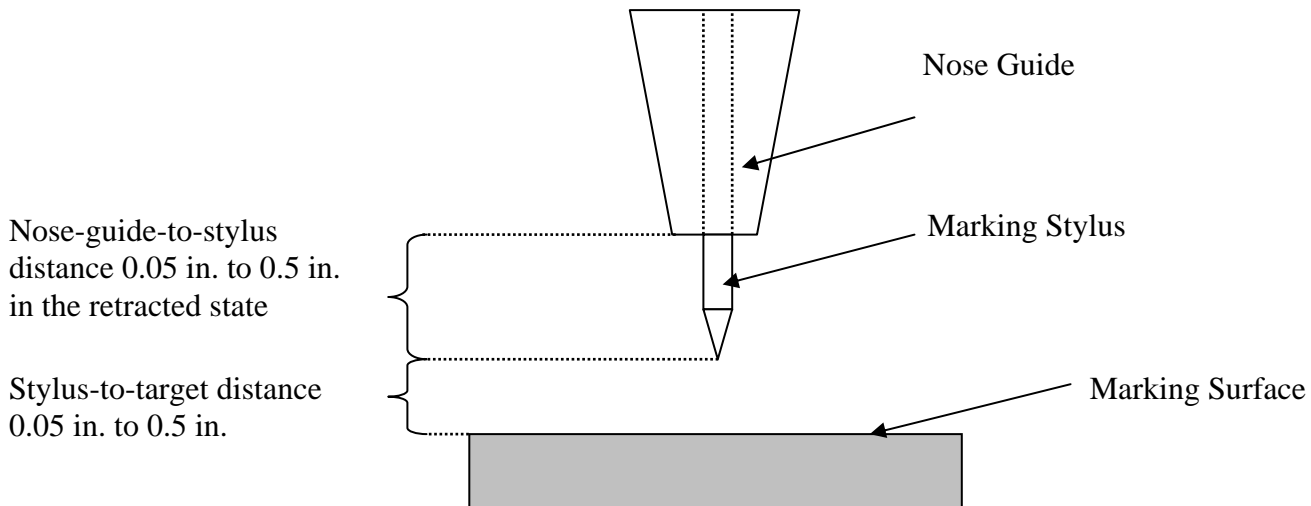

**Figure 15—Preferred Stylus-to-Target Configuration**

Prior to marking, operators need to check the pin/nose guide for visual damage or contamination that can interfere with the pin stroke. Checks are also needed to ensure that no play exists between the nose guide and the stylus, or in any of the joints in robotic marking head arms.

**APPROVED FOR PUBLIC RELEASE – DISTRIBUTION IS UNLIMITED**

## NASA-HDBK-6003C

The dot-peen stylus used to mark safety-critical and/or flight hardware needs to be modified to reduce the compressive stresses that can emanate from stylus impact. This is accomplished by rounding the point of the stylus to provide a 0.005 in. (0.13 mm) to 0.010 in. (0.25 mm) spherical radius. This is accomplished by rounding the point of the stylus to provide a 0.005 in. (0.13 mm) to 0.010 in. (0.25 mm) spherical radius.

Tests have concluded that a polished 30° (120° included) stylus provides the best light reflectivity angle for decoding, using fixed-station readers and proper illumination. Other styluses may be used on non-safety-critical components, but the styluses may not provide adequate light reflectivity for decoding using handheld or fixed-station readers. Since the verification of stylus angle and radius needs special measuring equipment, it is recommended that users standardize the stylus configuration as in figure 16. Quality assurance checks are needed as part of routine inspections of marking styluses to ensure proper conditions and to verify that worn/damaged styluses are properly machined to specification.

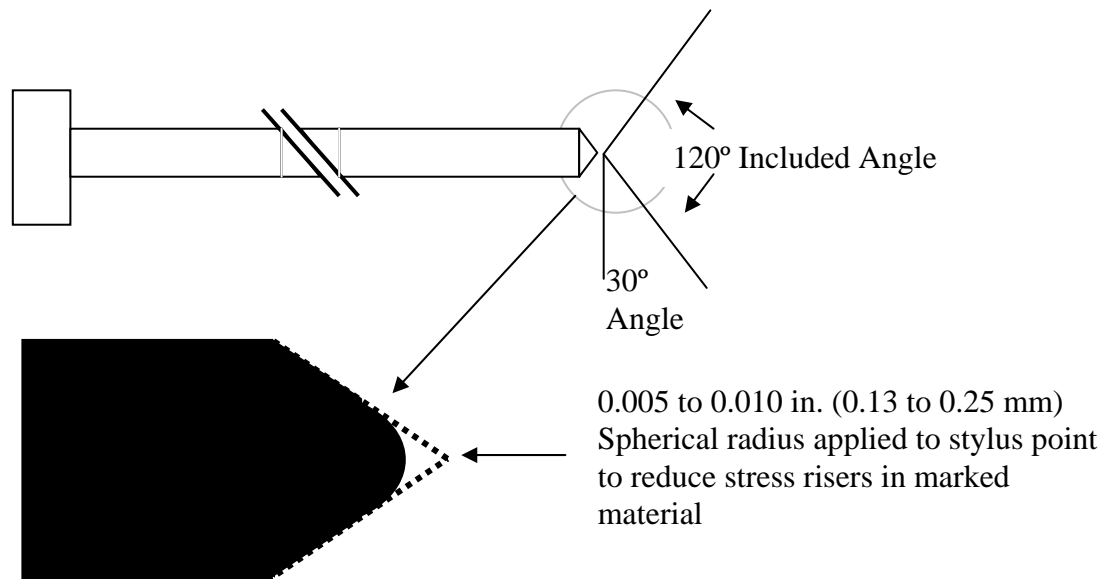

**Figure 16—Preferred Dot-Peen Stylus Configuration**

With the use of the preferred dot-peen stylus configuration illustrated above, depth can be calculated by measuring the average dot diameter as illustrated in figures 17 and 18. The acceptable dot-size range for NASA projects/programs is 0.01 in. to 0.02 in. (0.24 mm to 0.49 mm) unless otherwise approved. Table 1 provides dot depth data for the stylus radius of 0.15 mm (0.0059 in.). Table 2 provides dot depth data for the stylus radius of 0.08 mm (0.0031 in.).

**APPROVED FOR PUBLIC RELEASE – DISTRIBUTION IS UNLIMITED**

## NASA-HDBK-6003C

**Table 1—Dot Depth for Stylus Radius 0.15 mm (0.0059 in.)**

Dot Depth	Radius = 0,150 mm				Radius = 0,0059 inch			
	Dot Size	Stylus Angle			Dot Size	Stylus Angle		
		120°	90°	60°		120°	90°	60°
		Dot Depth				Dot Depth		
[mm]	[mm]	[mm]	[mm]	[inch]	[inch]	[inch]	[inch]	
0,214	0,020	0,020	0,020	0,0084	0,0008	0,0008	0,0008	
0,232	0,024	0,024	0,024	0,0091	0,0009	0,0009	0,0009	
0,253	0,029	0,029	0,029	0,0100	0,0011	0,0011	0,0011	
0,272	0,033	0,033	0,033	0,0107	0,0013	0,0013	0,0013	
0,293	0,039	0,039	0,039	0,0115	0,0015	0,0015	0,0015	
0,312	0,045	0,045	0,045	0,0123	0,0018	0,0018	0,0018	
0,333	0,051	0,051	0,051	0,0131	0,0020	0,0020	0,0020	
0,352	0,057	0,058	0,058	0,0139	0,0022	0,0023	0,0023	
0,373	0,062	0,066	0,066	0,0147	0,0024	0,0026	0,0026	
0,392	0,067	0,074	0,074	0,0154	0,0027	0,0029	0,0029	
0,413	0,073	0,083	0,083	0,0163	0,0029	0,0033	0,0033	
0,432	0,079	0,093	0,093	0,0170	0,0031	0,0037	0,0037	
0,453	0,085	0,103	0,103	0,0178	0,0033	0,0041	0,0041	
0,472	0,091	0,112	0,116	0,0186	0,0036	0,0045	0,0046	
0,493	0,097	0,122	0,130	0,0194	0,0038	0,0049	0,0051	
0,512	0,102	0,132	0,146	0,0202	0,0040	0,0052	0,0057	
0,533	0,108	0,143	0,162	0,0210	0,0042	0,0056	0,0064	
0,552	0,114	0,153	0,179	0,0217	0,0045	0,0060	0,0071	
0,573	0,120	0,163	0,197	0,0226	0,0047	0,0064	0,0077	
0,592	0,126	0,173	0,214	0,0233	0,0049	0,0068	0,0084	

**Table 2—Dot Depth for Stylus Radius 0.08 mm (0.0031 in.)**

Dot Depth	Radius = 0,080 mm				Radius = 0,0031 inch			
	Dot Size	Stylus Angle			Dot Size	Stylus Angle		
		120°	90°	60°		120°	90°	60°
		Dot Depth				Dot Depth		
[mm]	[mm]	[mm]	[mm]	[inch]	[inch]	[inch]	[inch]	
0,074	0,004	0,004	0,004	0,0029	0,0002	0,0002	0,0002	
0,094	0,007	0,007	0,007	0,0037	0,0003	0,0003	0,0003	
0,114	0,010	0,010	0,010	0,0045	0,0004	0,0004	0,0004	
0,134	0,014	0,014	0,014	0,0053	0,0006	0,0006	0,0006	
0,154	0,020	0,020	0,020	0,0061	0,0008	0,0008	0,0008	
0,174	0,026	0,026	0,026	0,0069	0,0010	0,0010	0,0010	
0,194	0,032	0,032	0,032	0,0076	0,0012	0,0013	0,0013	
0,214	0,037	0,040	0,040	0,0084	0,0015	0,0016	0,0016	
0,234	0,043	0,050	0,050	0,0092	0,0017	0,0020	0,0020	
0,254	0,049	0,060	0,062	0,0100	0,0019	0,0024	0,0025	
0,274	0,055	0,070	0,079	0,0108	0,0022	0,0028	0,0032	
0,294	0,060	0,080	0,096	0,0116	0,0024	0,0032	0,0038	
0,314	0,066	0,090	0,114	0,0124	0,0026	0,0036	0,0045	
0,334	0,072	0,100	0,131	0,0131	0,0028	0,0040	0,0052	
0,354	0,078	0,110	0,148	0,0139	0,0031	0,0044	0,0059	
0,374	0,083	0,121	0,165	0,0147	0,0033	0,0047	0,0065	
0,394	0,089	0,131	0,182	0,0155	0,0035	0,0051	0,0072	
0,414	0,095	0,141	0,199	0,0163	0,0037	0,0055	0,0079	
0,434	0,101	0,151	0,217	0,0171	0,0040	0,0059	0,0086	
0,454	0,106	0,161	0,234	0,0179	0,0042	0,0063	0,0092	
0,474	0,112	0,171	0,251	0,0187	0,0044	0,0067	0,0099	

**APPROVED FOR PUBLIC RELEASE – DISTRIBUTION IS UNLIMITED**

**NASA-HDBK-6003C**

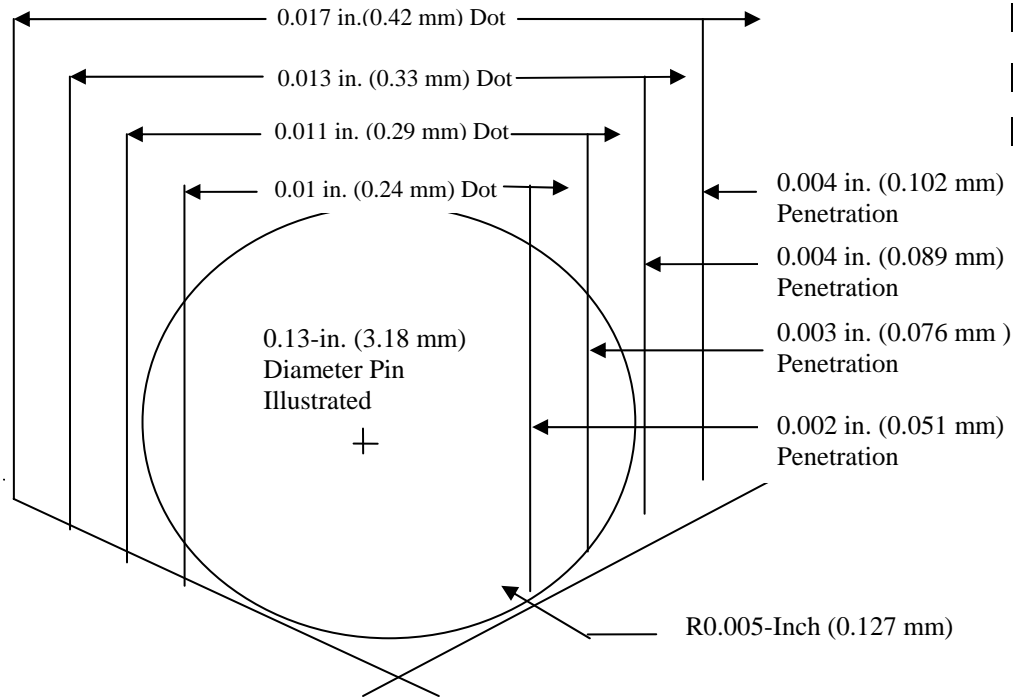

**Figure 17—Acceptable Dot Size Range Using 120° Stylus with 0.005 in. (0.127 mm) Radius**

**NASA-HDBK-6003C**

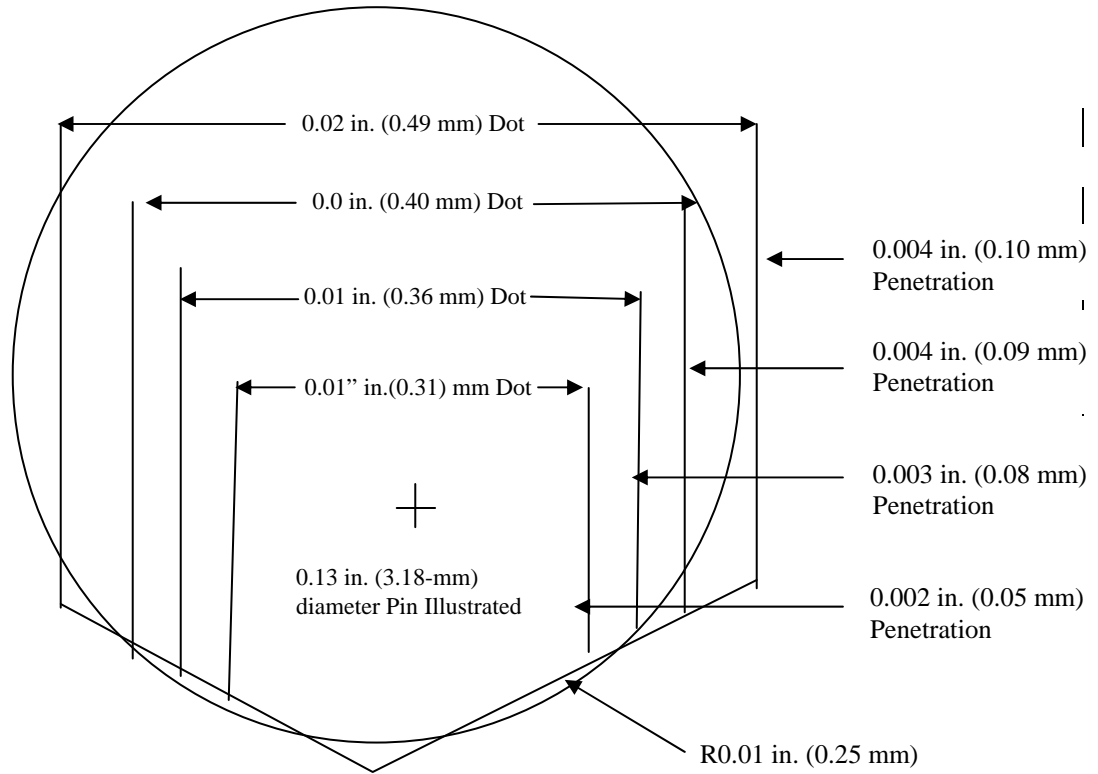

**Figure 18—Acceptable Dot Size Range Using 120° Stylus with 0.01 in. (0.25 mm) Radius**

The part to be marked needs to be securely gripped in an approved fixture to prevent movement during marking.

The nominal shape of a dot-peened data cell is circular. Dot spacing is the horizontal or vertical distance between center points of contiguous cells. Dot spacing should be equal to the cell size of a printed Data Matrix symbol (see figure 19). Dot diameter needs to be 80 percent of the dot spacing to allow for a dot size tolerance of  $\pm 10\%$ . Table 3 provides dot depth data for the stylus radius of 0.10 mm (0.0039 in.).

**NASA-HDBK-6003C**

**Table 3—Dot Depth for Stylus Radius 0.10 mm (0.0039 in.)**

Dot Depth	Radius = 0,100 mm				Radius = 0,0039 inch			
	Dot Size	Stylus Angle			Dot Size	Stylus Angle		
		120°	90°	60°		120°	90°	60°
	[mm]	Dot Depth			[inch]	Dot Depth		
	[mm]	[mm]	[mm]		[inch]	[inch]	[inch]	
0,158	0,017	0,017	0,017	0,0062	0,0007	0,0007	0,0007	
0,178	0,021	0,021	0,021	0,0070	0,0008	0,0008	0,0008	
0,198	0,026	0,026	0,026	0,0078	0,0010	0,0010	0,0010	
0,218	0,032	0,032	0,032	0,0086	0,0012	0,0013	0,0013	
0,238	0,038	0,040	0,040	0,0094	0,0015	0,0016	0,0016	
0,258	0,043	0,047	0,047	0,0102	0,0017	0,0019	0,0019	
0,278	0,049	0,056	0,056	0,0109	0,0019	0,0022	0,0022	
0,298	0,055	0,065	0,065	0,0117	0,0021	0,0026	0,0026	
0,318	0,061	0,076	0,078	0,0125	0,0023	0,0030	0,0031	
0,338	0,067	0,086	0,092	0,0133	0,0026	0,0034	0,0037	
0,358	0,072	0,096	0,108	0,0141	0,0028	0,0038	0,0043	
0,378	0,078	0,106	0,125	0,0149	0,0030	0,0042	0,0050	
0,398	0,084	0,116	0,143	0,0157	0,0033	0,0046	0,0057	
0,418	0,090	0,126	0,160	0,0165	0,0035	0,0050	0,0063	
0,438	0,096	0,136	0,178	0,0172	0,0037	0,0054	0,0070	
0,458	0,101	0,146	0,195	0,0180	0,0040	0,0058	0,0077	
0,478	0,107	0,157	0,212	0,0188	0,0042	0,0061	0,0084	
0,498	0,113	0,167	0,230	0,0196	0,0044	0,0065	0,0091	
0,518	0,119	0,177	0,247	0,0204	0,0047	0,0069	0,0097	
0,538	0,125	0,187	0,264	0,0212	0,0049	0,0073	0,0104	
0,558	0,130	0,197	0,282	0,0220	0,0051	0,0077	0,0111	
0,578	0,136	0,207	0,299	0,0228	0,0054	0,0081	0,0118	
0,598	0,142	0,217	0,318	0,0235	0,0056	0,0085	0,0125	

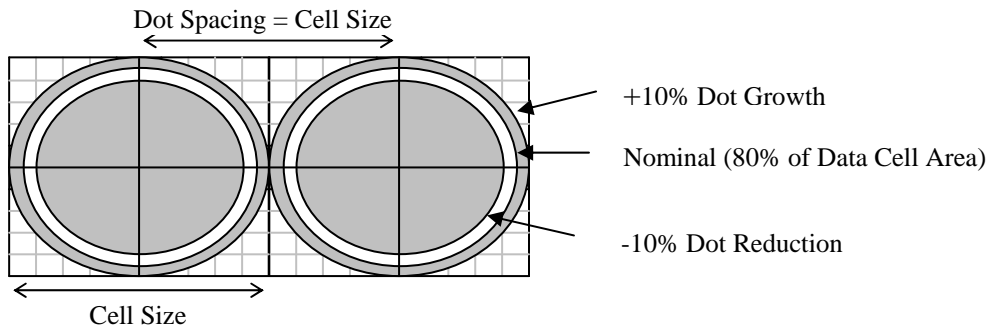

**Figure 19—Dot Size Tolerance**

Dot spacing should be adjusted (machine adjustment) to ensure that the individual data cells touch or are close to each other. Gaps that exceed 50 percent of the dot size adversely affect symbol readability. Data cells should not overlap (see figure 20 for proper dot peen spacing). Figure 21 provides examples of dot peen spacing.

**NASA-HDBK-6003C**

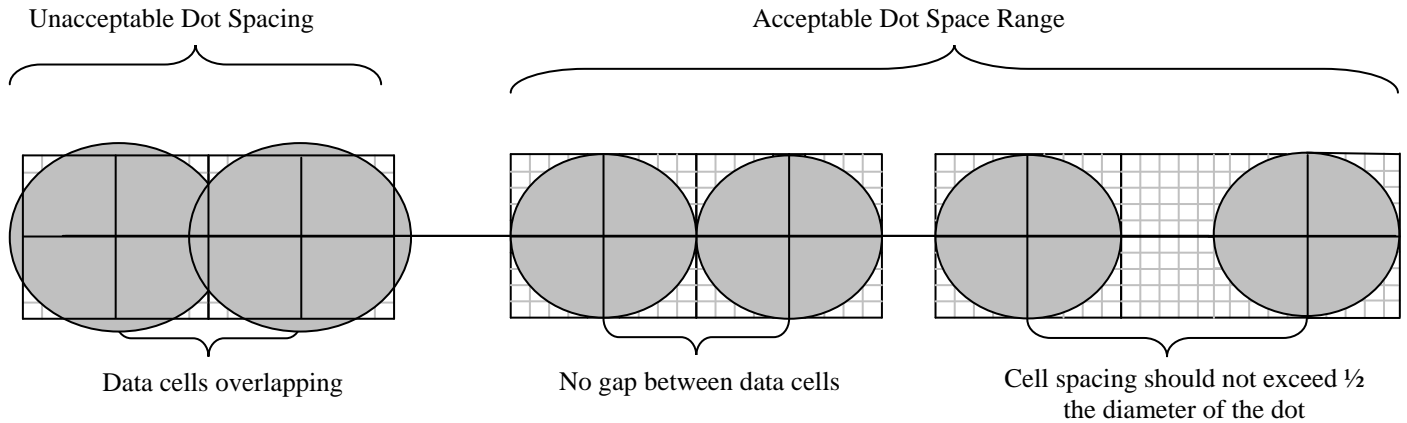

**Figure 20—Proper Dot Pen Spacing**

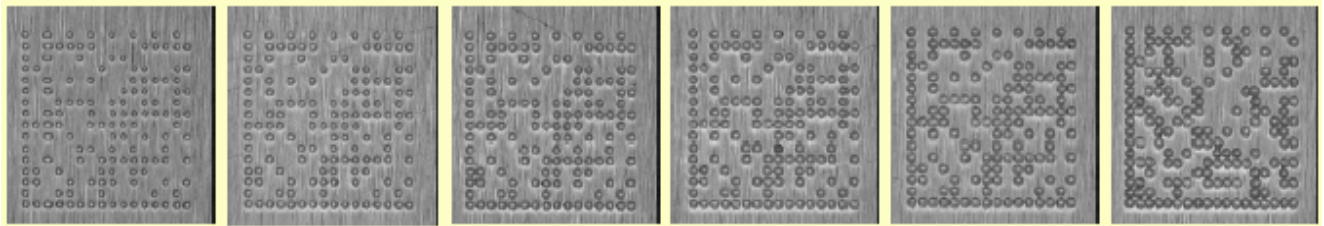

**Figure 21—Examples of Dot Pen Spacing**

Precise dot alignment along the horizontal and vertical alignment bars is preferred. Part slippage in the holding fixture, however, can result in a symbol's being skewed as illustrated in figure 22. The decoding software used to decipher the data contained within the symbol is designed to overcome reliably up to 7.18° of skew beyond perpendicular. Skew angles beyond this value are prohibited on NASA programs/projects.

**NASA-HDBK-6003C**

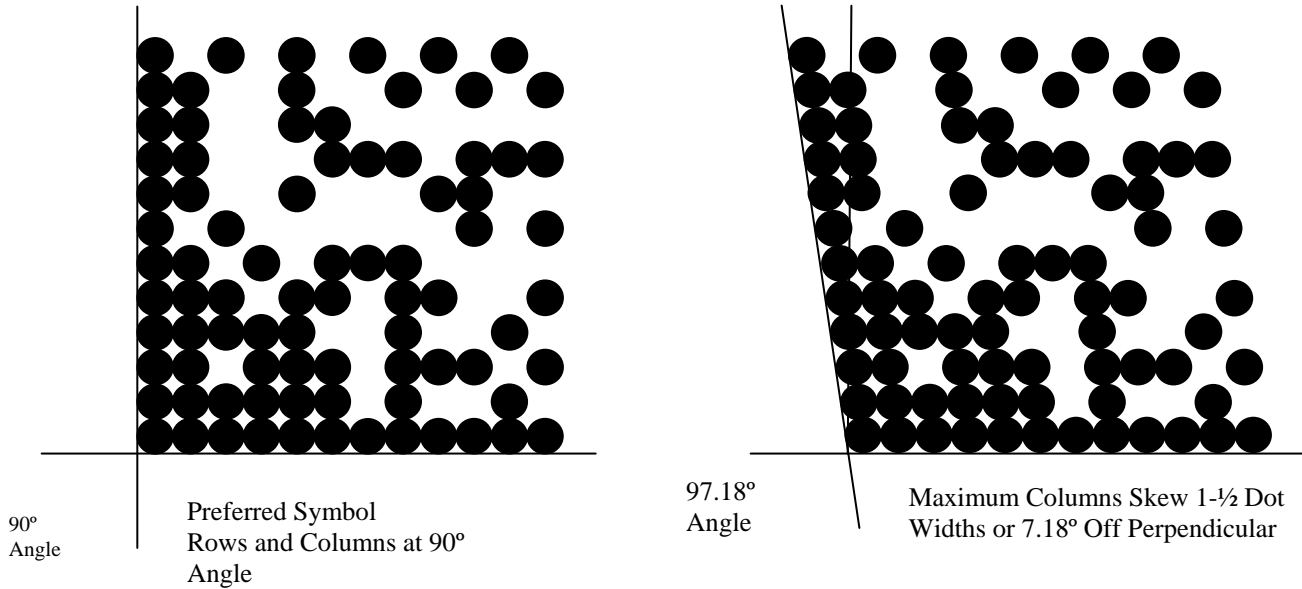

**Figure 22—Row and Column Misalignment**

Off-center dots resulting from fluctuations in throw force, stylus deflections, or similar conditions are tolerated by the decoding software if they are not placed more than 30 percent off normal cell center position. Dots exceeding this tolerance force the software to seek out and utilize redundant data (error correction) embedded in other portions of the symbol. If cells more than 30 percent off center strike both the primary and redundant data elements encoded into the symbol, the symbol cannot be read. Since the position of the off-center cells in relation to the redundant data cannot be predetermined, limits on the maximum number of off-center cells cannot be defined. Over/under-printed cells also have no effect on decoding until the tolerances exceed 30 percent in either direction (up or down) as illustrated in figure 23. Information related to off-center and over/under-printed cells and used overhead can be obtained by symbol verification software. Figure 24 illustrates a center offset marking error and overlapping data cells. Figure 25 illustrates a marking error with overlapping data cells.

## NASA-HDBK-6003C

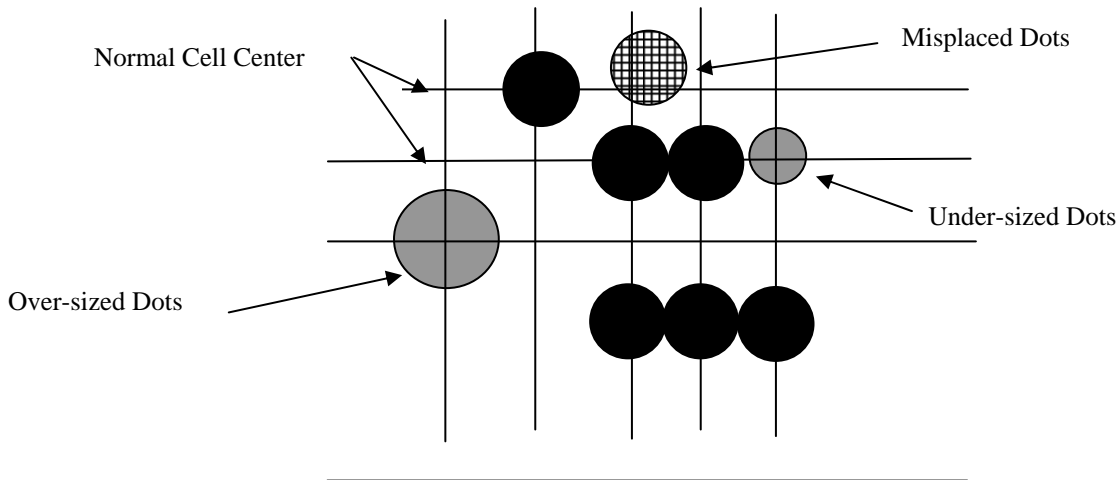

**Figure 23—Improper Dot Marking Conditions**

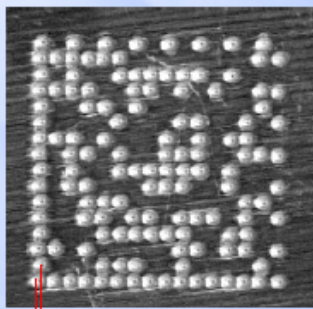

### Center Offset

Every second row in this symbol has a horizontal center offset.

This center offset is typical for a machine which has too much axial clearance. The dots were marked bi-directionally.

This problem can be corrected by programming the machine to mark only from one direction.

**Figure 24—Center Offset Marking Error and Overlapping Data Cells**

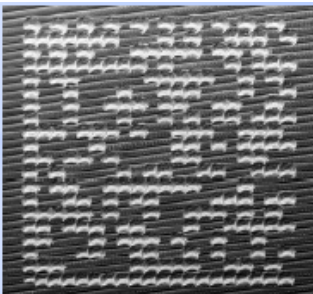

### Dots with a Comma Form

This form can be caused by a chipped stylus tip or a too-high feed rate.

First check the condition of the stylus tip. If the tip is o.k., then reduce the feed rate.

**Figure 25—Marking Error with Overlapping Data Cells**

## NASA-HDBK-6003C

Because dot peening produces a no-contrast mark, successful reading depends on the application of colored backfill media or use of a lighting solution that produces artificial contrast. Projecting light at an angle perpendicular to sidewalls of the dot to reflect light directly to the reader lens (dark field) creates a data cell that looks bright white to the imager. If the lighting angle is further lowered, shadows can be cast into the dots (bright field) to produce data cells that appear black to the imager. Both of these lighting configurations, as well as lighting to illuminate symbols placed in recesses or adjacent to protruding surfaces, is accomplished under static conditions where fixed-station readers are utilized with moveable light sources. Hand-held readers that are typically manufactured with fixed-position lighting can have difficulty reading symbols that are placed near obstructions blocking illumination. Consequently, if field-site reading is anticipated, it is necessary to conduct an engineering evaluation prior to placing symbols within recesses or adjacent to structures that protrude above the marking surfaces. For further information, refer to NASA-STD-6002, section 4.2.4.5, Marking Location.

**NOTE:** To ensure readability, a minimum contrast of 20 percent is needed between the reflectance of the dot and the surrounding substrate. Various densitometers can provide such measurements nondestructively.

Figure 26 illustrates a properly applied and illuminated dot-peen marking. The lighting setup used with the fixed-station reader needs to be adjusted to compensate for differences in surface roughness and stylus wear.

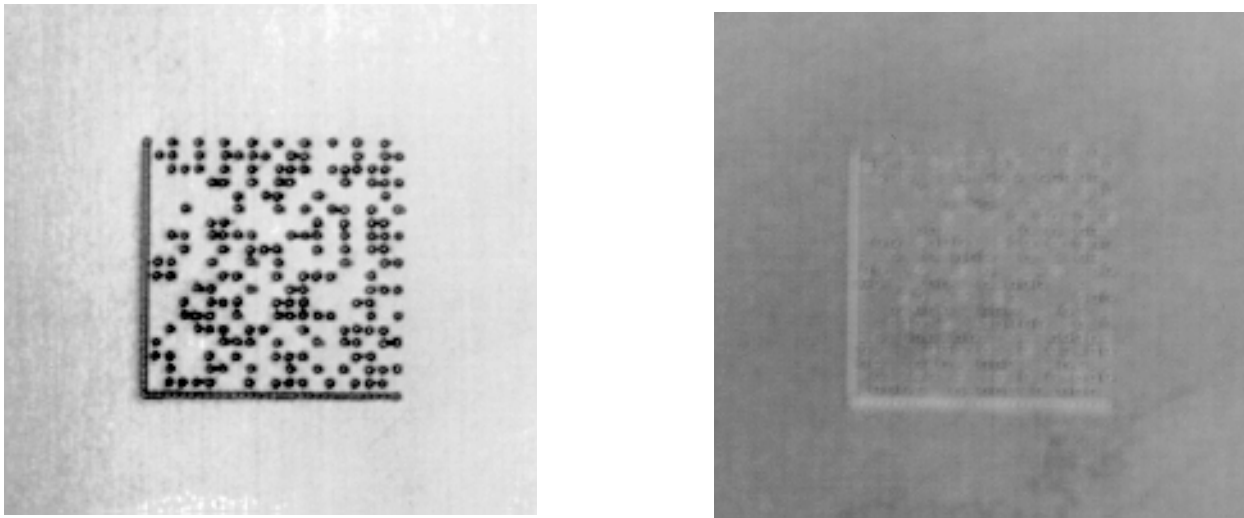

**Figure 26—Dot Peen Marking With and Without Proper Illumination**

Dot-peen marking is generally limited to parts exposed to harsh manufacturing, operational, and/or refurbishment conditions. Since many of these conditions change surface properties and/or color, it may be necessary to modify the surface to restore readability. This can be accomplished using a weld cleaner to remove oxides from the surface or by back filling the dot recesses with a removable media of contrasting color, usually dry-erase ink or chalk.

**APPROVED FOR PUBLIC RELEASE – DISTRIBUTION IS UNLIMITED**

## NASA-HDBK-6003C

Dot-peen marking should not be used in the following conditions:

- Materials less than 0.02 in. (0.51 mm) thick (see NASA-STD-6002, section 4.2.1.9, Surface Thickness)
- Electrical Discharge Machining (EDM), grit-blasted, machined, and shot-peened surfaces between 8 and 250 micro-in. (0.0002 and 0.0063 mm) using a single dot per cell
- Cast surfaces between 8 and 120 micro-in. (0.0002 and 0.003 mm) using a single dot per data cell
- Multi-layer fabric reinforced laminates
- Non-metallic materials that chip, shatter, or regain shape after impact
- Within a distance of four times the material depth from any edge, weld, or forming radius
- High-pressure system components
- Metals hardened above 54 on the Rockwell Hardness C Scale without prior approval
- Highly stressed parts without prior approval

### 4.2.2.3 Electro-chemical Marking

Electro-chemical marking (ECM) can be used on all conductive metallic parts. This marking technology has undergone drastic changes since its inception in the aircraft industry of the 1940s. Initially, marks lacked resolution, the process was not repeatable, and neutralizing was needed to remove corrosive agents. Now, fixed voltage power supplies, typewriter- or stylus-cut stencils, and corrosive electrolytes are no longer characteristic of the methodology. ECM is one of the major processes used for critical parts, because it does not weaken, deform, or fracture the substrate beyond the marking depth. All metals can be marked. Today's ECM system is characterized by processor-controlled power units, computer-generated stencils, and benign electrolytes. Resolution meets or exceeds DPM needs, the process is repeatable (controllable), and neutralizing after marking is no longer needed.

Modern power units are critical in this revolutionized marking system. Low-voltage ( $\leq 40$  V) processor-controlled Selective Catalytic Reduction (SCR) units provide control of power application including Alternating Current/Direct Current (AC/DC), AC frequency, time, voltage, and power profile. The result is precise, repeatable control of the mark.

Thermal and photo-sensitive silk-screen materials are now used to make marking stencils. A thermo-stencil fabricating system consists of computer symbol-creation software, stencil material, and a special thermal printer. In this method, the pattern to be marked is computer-generated. Then, thermo-sensitive material is passed through a special desktop printer, which uses a thermal print head to deposit non-conductive ink onto the silk-screen material in the non-image area to form the mark. This process is fast; the stencil is ready to use as it emerges from the printer.

For better resolution and stencil durability, photo stencils are used. A desktop photo-stencil fabricating system is available. This system consists of a computer, symbol creation software,

**APPROVED FOR PUBLIC RELEASE – DISTRIBUTION IS UNLIMITED**

## NASA-HDBK-6003C

laser printer, photo-sensitive silk-screen stencil, exposure unit, and washer/dryer unit. In this process, the pattern to be marked is laser-printed on a transparent medium to form a “negative.” The negative is placed over the photo-sensitive stencil material in the exposure unit and exposed to UV light. The stencil material is then placed in the washer (or an open tray) where the unexposed photo-resist is cleaned. The finished stencil is then dried in the dryer (or open air). This proven technology is inexpensive and eliminates the need for stencil preparation by outside vendors.

Modern electrolytic chemistry has developed electrolytes that are safe to handle and corrosion-free; marked objects do not need neutralization following the marking process. With some metal/electrolyte combinations, colored marks (black, white, blue, etc.) can be obtained.

ECM is applied to metallic surfaces prior to the application of protective coatings. ECM may be accomplished by either of two processes: electro-chemical etching or electro-chemical coloring. The first process uses electrolysis to remove metal from the object surface. The second process marks by discoloring the object surface without removing, melting, or vaporizing the material. The first method uses a DC-power source; the second uses AC. In both methods, the voltages are low to ensure operator safety.

Marking system features are listed below:

- Low acquisition cost
- Ease of operation, minimal operator training
- Outside vendors not needed to produce marking stencils
- Applicable to short runs; jigs/fixtures usually not needed
- Flat surfaces, as well as simple curved surfaces, easily marked
- Portable: carry the system to the (large) part high resolution: The 14 x 14 data matrix symbol can be marked onto a 3/16 x 3/16 in. (4.76 x 4.76 mm) square.

### 4.2.2.3.1 Electro-Chemical Etching

Electro-chemical etching (ECE) removes metal from an object by electrolysis. The mark from this process is the least likely of intrusive marking methods to weaken, deform, or fracture the metal beyond the marking depth. Only the molecular structure involved in the mark is altered (removed).

A DC potential is applied across an electrolyte, separating the part and the applicator electrode (essentially a sponge soaked in electrolyte). Metal is removed from the part and transferred to the applicator pad. The shape/pattern of the mark is determined by a stencil.

All conductive metal parts can be marked by this process. (Anodized parts, normally considered insulated by the anodized coating, can also be marked.) Etching depths can be controlled, and range from 0.0001 in. (0.003 mm) to 0.01 in. (0.25 mm). Materials as thin as 0.001 in. (0.025 mm) can be etched.

**APPROVED FOR PUBLIC RELEASE – DISTRIBUTION IS UNLIMITED**

## NASA-HDBK-6003C

Following etching, the part can be anodized and/or protected with clear coatings. Etching also can be followed by electro-chemical coloring (see section 4.2.2.3.2) to enhance the contrast of the mark.

### 4.2.2.3.2 Electro-Chemical Coloring

Electro-chemical coloring is one of the least intrusive marking methods currently in use. This process marks metallic materials without burning, melting, vaporizing, or otherwise deforming the material. This process is set up and operates in a manner similar to electro-chemical etching except that an AC potential is used instead of DC. In this case, metal is not removed; it is colored (oxidized). No pigments are added in this process.

The electro-chemical coloring process produces a high-quality mark that does not disrupt the part surface, although the chemical reaction which produces the coloration may alter the surface properties of the material. The penetration of coloration into the metal is controlled by the amplitude and frequency of the AC potential. The resulting color is determined by the chemical properties of the metal and the electrolyte used.

ECM is not an appropriate marking method for the following:

- Non-metallic objects
- Objects characterized by compound curves of small radius. (Simple curves, cylinders, are easily marked consistent with this document.)

### 4.2.2.4 Engraving/Milling

Engraved and milled markings are applied by removing material from the part's surface using a computer-guided carbide-tipped cutter or diamond drag. The quality of the marking is controlled by adjusting cutter depth, air pressure, rotation, and dwell time. Marking readability can be improved by backfilling the marking recesses with a material of contrasting color. Engraved markings can be applied to glass; plastic; and phenolic, ferrous, and non-ferrous metals.

Engraving/milling should not be applied to the following:

- Materials less than 0.06 in. (1.5 mm) thick
- High-pressure system components
- Components subjected to severe loads
- Multi-layer or fabric-reinforced laminates
- Alloys or other metals hardened above 32 Rockwell C

Minimum distances of symbol edges of twice the base material thickness should be located from any edge, including holes.

**APPROVED FOR PUBLIC RELEASE – DISTRIBUTION IS UNLIMITED**

## NASA-HDBK-6003C

### 4.2.2.5 Fabric Embroidery/Weaving

Fabric marking can be incorporated into the cloth during manufacture (fabric weaving) or after manufacture using embroidery methods. Both processes are computer controlled. The fabric-weaving process is generally utilized to create identification labels that are sewn onto clothing or similar articles. Fabric embroidery involves stitching part identification markings onto knits, cotton, canvas, leather, and many other materials after their manufacture, using a wide range of thread sizes and materials. Figure 27 illustrates a data matrix symbol created using fabric weaving.



**Figure 27—Cloth Label Produced Using Fabric-Weaving Technique**

Limitations include the following:

- Generally restricted to tight-weave fabrics
- Cannot be used with threads made of Nomex or impregnated with additives to support use in high temperatures

### 4.2.2.6 Direct Laser Marking

#### 4.2.2.6.1 Laser

Laser utilizes amplified light to mark products. The heart of the laser-marking device is the lasing medium, which contains atoms that store photon energy and can be stimulated to release this energy in a concentrated pulse. The medium may be a gas mixture (CO<sub>2</sub>, Helium-Neon, etc.), a semiconductor substrate (laser diode), a liquid (dye laser), or a solid crystal (Nd:YAG, Nd:YLF, etc.). Depending on the medium used, different light wavelengths are produced. For marking, these wavelengths can be divided into three major categories: short wavelengths, visible wavelengths, and long wavelengths, as illustrated in figure 28.

**APPROVED FOR PUBLIC RELEASE – DISTRIBUTION IS UNLIMITED**

## NASA-HDBK-6003C

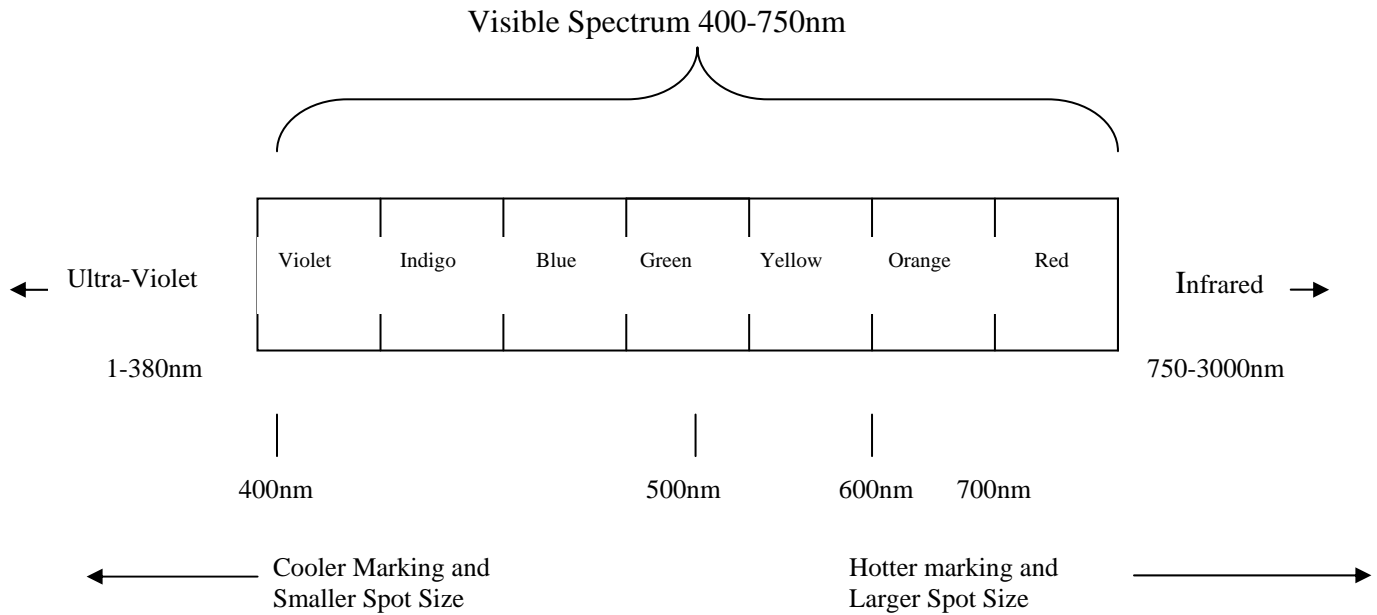

**Figure 28—Laser Light Wavelengths**

### 4.2.2.6.2 Short Wavelength Lasers

Wavelength lasers, also known as ultraviolet lasers, utilize light in the lower end of the light spectrum and use a cold-marking process. Lasers in this category include excited dimmer (excimer) lasers. Short wavelength lasers mark by ablation and are preferred for use in safety-critical applications. Excimer lasers are used to mark extremely thin materials, wire insulation, and very small parts (see figure 29).

## NASA-HDBK-6003C



Photograph Magnified 25 Times

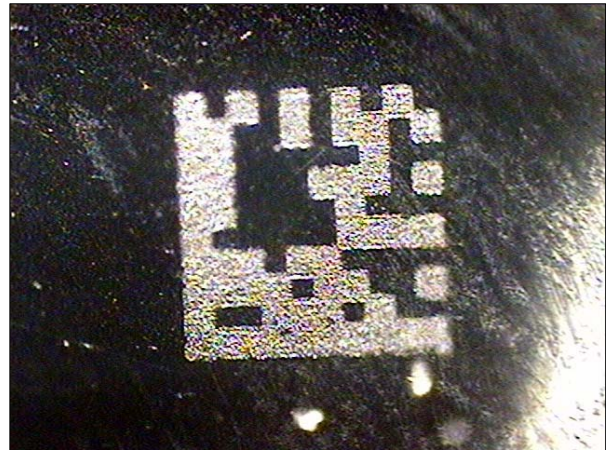

Photograph Magnified 200 Times

**Figure 29—2-D Markings Applied to the Head of a Straight Pin  
Using an Ar-F Excimer Laser**

### 4.2.2.6.3 Visible Wavelength Lasers

Visible wavelength lasers utilize light in the visible light spectrum and produce marks using heat action or pressure. Lasers in this category include Ruby-Neodymium doped: Yttrium Lithium Fluoride (Nd:YLF), Neodymium doped: Yttrium Aluminum Garnet (Nd:YAG), Neodymium doped: Yttrium Aluminum Perovskite (Nd:YAP), and Neodymium doped: Yttrium Vanadate Orthovanadate (Nd:YVO4). Visible wavelength lasers are generally used to mark metal substrates.

### 4.2.2.6.4 Long Wavelength Lasers

Long wavelength lasers, also known as infrared lasers, utilize light in the infrared spectrum, and CO<sub>2</sub> lasers are included in this category. CO<sub>2</sub> lasers are effective for marking organic materials such as wood, leather, and some plastics.

The laser directs a concentrated beam of coherent light onto a part surface for marking. The marking beam is controlled by a high-speed computer that moves the beam by reflecting it off galvanometer-controlled mirrors. Movement of the laser can reach speeds of 2000 mm (78.74 inches)/second with an accuracy of 0.01 mm (.0003937 inches). Laser peening can be performed with a single laser pulse, eliminating the need for high-speed motion.

**APPROVED FOR PUBLIC RELEASE – DISTRIBUTION IS UNLIMITED**

## NASA-HDBK-6003C

Six types of markings can be made:

- Changing metal color by tempering (annealing)
- Changing plastic color through heat action on pigments embedded in the material
- Changing metal color by surface melting (laser etching)
- Changing surface texture by material vaporizing (laser engraving)
- Removing coatings to expose an underlying substrate of contrasting color (coat and remove)
- Generating a shockwave that indents a pattern (peening)

Marking quality is controlled by adjusting the machine settings: lamp current (power in amps), pulse rate (frequency in kilohertz [kHz]), beam velocity (mm per second), and line/dot spacing.

**CAUTION:** Laser beams emitted in the visible spectrum penetrate clear surfaces without effect. Consequently, if these devices are used to mark products with clear protective finishes, a buildup of hot gases occurs between the part surface and the coating. This condition can result in bubbling and/or breakage of the finish seal. Therefore, the use of this type of laser for marking clear-coated parts is not permitted.

### 4.2.2.7 Laser Marking Methods

The various direct laser marking methods authorized for use in the aerospace industry are listed below.

#### 4.2.2.7.1 Laser Coloring

Laser coloration is a process used to discolor metallic substrate material without burning, melting, or vaporizing the material. This process is performed by passing a low-power laser beam across a surface at slow speed to discolor the area of the mark (see figure 30). This method produces a high-quality, high-contrast marking that does not disrupt the surface. Laser-colored markings penetrate into deep surface imperfections, allowing the marking of surfaces with roughness levels up to 500 micro-in. (0.01 mm). Laser coloring causes fewer surface disruptions than the intrusive-marking methods used to mark aerospace parts. The process, however, can have an adverse effect on materials that have been previously heat treated. It can also reduce the corrosion-resistant properties of some stainless steel alloys. These effects can be minimized or eliminated by using carefully selected laser-marking parameters.

**APPROVED FOR PUBLIC RELEASE – DISTRIBUTION IS UNLIMITED**

## NASA-HDBK-6003C

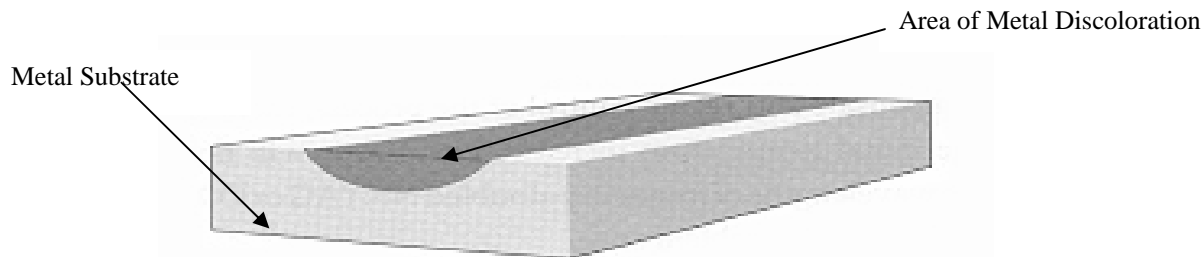

**Figure 30—Marking Applied to a Surface Using the Laser Coloration Process**

Laser coloration markings properly applied to smooth surfaces cannot be felt when rubbed with the finger and appear smooth when viewed under low (10X) magnification.

The laser coloring process is not recommended for the following:

- Parts thinner than 0.10 in. (2.54 mm)
- Carbon and stainless steel alloys

#### 4.2.2.7.2 Laser Etching

Laser etching is similar to laser coloring except that the heat applied to the surface is increased to a level that causes substrate surface melting. The advantage of using this technique instead of laser coloring on metal is increased marking speed. Excellent results can be routinely obtained at penetration depths of less than 0.001 in. (0.025 mm). This technique, however, should not be used on some metals in safety-critical parts, because cracks produced in the molten metal during cooling can propagate into the underlying surface material. These cracks can expand downward if the part is stressed and/or after repeated hot and cold cycles, and can lead to part failures.

Laser etching is frequently used to mark plastics that contain pigmented materials that are discolored by the laser beam to produce striking color contrast (see figure 31, view A). Additives can be made to enhance contrast on plastics that do not mark well.

The laser-etched marking can generally be felt when rubbed with a finger, and the marking has a corn row (swipe mode) or cratered (dot mode) appearance when viewed under low (10X) magnification. Laser etching is not recommended for parts thinner than 0.05 in. (1.27 mm).

Laser etching can be used in safety-critical applications to mark coatings applied to substrates, as illustrated in figure 31, view B. The process, known as “coat and mark,” has been successfully demonstrated on materials used to coat aircraft aluminum surfaces and external aircraft engine components subjected to temperatures up to 2000°F.

**APPROVED FOR PUBLIC RELEASE – DISTRIBUTION IS UNLIMITED**

## NASA-HDBK-6003C

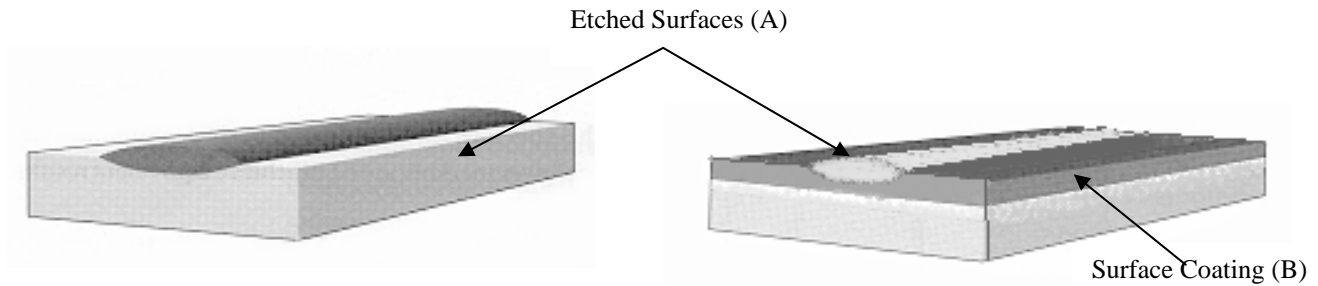

**Figure 31—Laser Etching Applied Directly to a Surface (A) and to Surface Coating (B)**

This method is limited because the appropriate approval is required when laser-etched markings are applied directly to uncoated parts used in safety-critical applications.

### 4.2.2.7.3 Laser Engraving

Laser engraving involves more heat than laser etching, and results in the removal of substrate material through vaporization. This technique produces a deep-light marking similar to a deep electro-chemical etch marking. The major advantage of this laser marking technique is speed, because it is the quickest laser marking that can be produced. The high contrast obtained by laser coloring or etching cannot be obtained by laser engraving, because the discolored material is vaporized and ejected during the marking process. Although this method appears to be the most vigorous laser marking technique, it generally produces less damage to the substrate than laser etching does. However, because it can produce micro-cracking in some materials, a metallurgist should be consulted before use in safety-critical applications. Like laser etching, direct laser engraving (figure 32) can be easily observed by touch and low-power microscope (10X) magnification. Laser engraving is not recommended on parts less than 0.10 in. (2.54 mm) in thickness.

Laser engraving is acceptable in safety-critical applications when used in conjunction with a “coat and remove” process. This process involves the coating of a part with a medium of contrasting color that is subsequently removed to expose the underlying material (see figure 32). The marking is as resilient as the surface coating used in the process.

**APPROVED FOR PUBLIC RELEASE – DISTRIBUTION IS UNLIMITED**

## NASA-HDBK-6003C

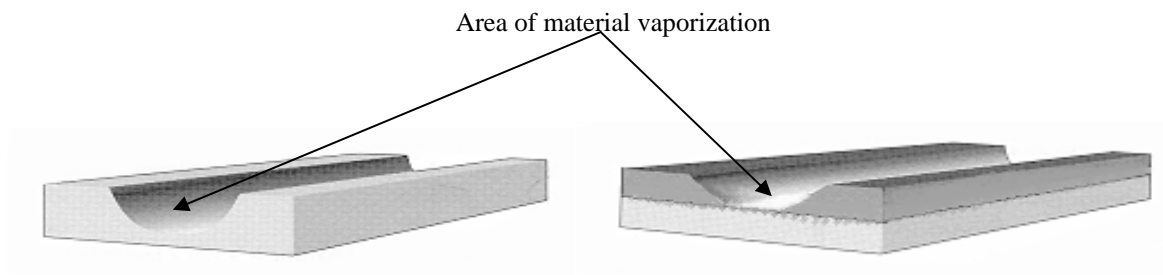

**Figure 32—Laser Engraving Applied Directly to a Surface (left) and to a Surface Coating (right)**

This method is limited because the appropriate approval is required when laser-engraved markings are applied directly to uncoated parts used in safety-critical applications.

### 4.2.2.8 Lasershot Peening

Lasershot-peen marking is a process for metal components that imprints an identification coding and leaves the surface in residual compressive stress. The technique involves the use of a laser-peening system that impresses an image in the near-field spatial profile of the laser beam onto the metal in the form of a relief pattern. The creation of a compressive stress is highly advantageous for safety-critical parts since it leaves the component resistant to fatigue failure and stress-corrosion cracking.

In the laser-peening process, a thin layer of absorptive material is placed over the area to be peened, and a thin, approximately 1-mm-thick layer of fluid is flowed over the absorption layer. A high-intensity laser with fluence of approximately  $100 \text{ J/cm}^2$  and pulse duration of 15 ns, illuminates and ablates material from the absorption layer, creating an intense pressure pulse inertially confined by the water layer. This pressure creates a shockwave that strains the metal surface in a two-dimensional pattern directly correlated to the laser-intensity profile at the metal surface. With creation of a desired pattern upstream in the light field and imaging of it onto the metal surface, the entire desired pattern can be pressure-printed with a single laser pulse. With spatial light modulation of the near-field beam and subsequent imaging of this pattern onto the metal, a new data matrix can be created with each laser pulse. Any 2-D or 3-D pattern can be printed, including the data matrix standard (see figure 33), as well as bar codes and alpha- numerics.

A breakthrough in laser technology employing an Nd:glass laser and a wave front correction technology called “phase conjugation” enables the building of a laser system that can operate at 6 pulses per second with output energy of up to 100J. This represents a fundamental capability of peen marking six complete data matrices per second.

**APPROVED FOR PUBLIC RELEASE – DISTRIBUTION IS UNLIMITED**

## NASA-HDBK-6003C

Lasershot-peen marking can be used on any non-brittle material that undergoes plastic strain upon reaching its stress yield point. It does not work well on materials that fracture, such as glass. The process can be combined with an overall shot-peening or lasershot peening of the surface to provide excellent protection against fatigue failure and stress-corrosion cracking.

Lasershot-peening should not be used in the situations listed below:

- Materials less than 0.020 in. (0.508 mm) thick (see NASA-STD-6002, section 4.2.1.9, Surface Thickness)
- Electrical Discharge Machining (EDM), grit-blasted, machined, and shot-peened surfaces between 8 and 63 micro-in. (0.0002 and 0.0016 mm) using a single dot per data cell
- Cast surfaces between 8 and 63 micro-in.(0.0002 and 0.0016 mm) using a single dot per data cell
- Multi-layer fabric-reinforced laminates
- Non-metallic materials that chip, shatter, or regain shape after impact
- Within a distance of four times the material depth from any edge, weld, or forming radius
- High-pressure system components
- Metals hardened above 54 on the Rockwell Hardness C Scale without appropriate approval

**APPROVED FOR PUBLIC RELEASE – DISTRIBUTION IS UNLIMITED**

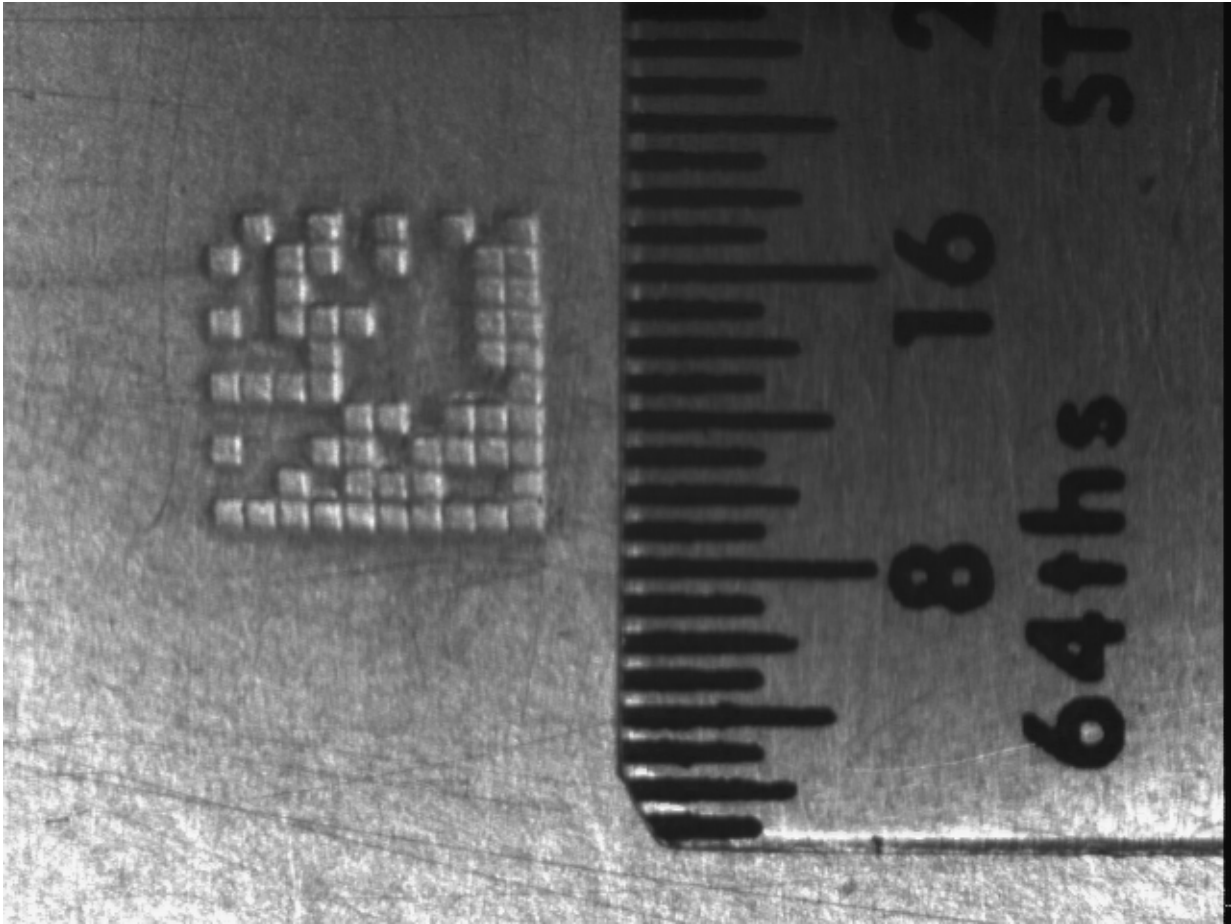

**Figure 33—Magnified Image of Laser Shot-Peen Marking**

#### 4.2.2.9 Laser-Induced Surface Improvement (LISI)

LISI is similar to laser bonding except that the additive material is melted into the metallic host substrate to form an improved alloy with high-corrosion resistance and wear properties. LISI is generally used as a surface coating, but can be applied directly to parts to form a symbol (see figure 34). Where needed, a LISI patch can be applied that is subsequently marked using another intrusive or non-intrusive marking method (see figure 34). The process is generally used to mark steel parts that rust when exposed to their normal operating environment. Figure 35 illustrates a cross section of a LISI mark as seen by a scanning electron microscope.

LISI is limited to metallic alloys.

NASA-HDBK-6003C

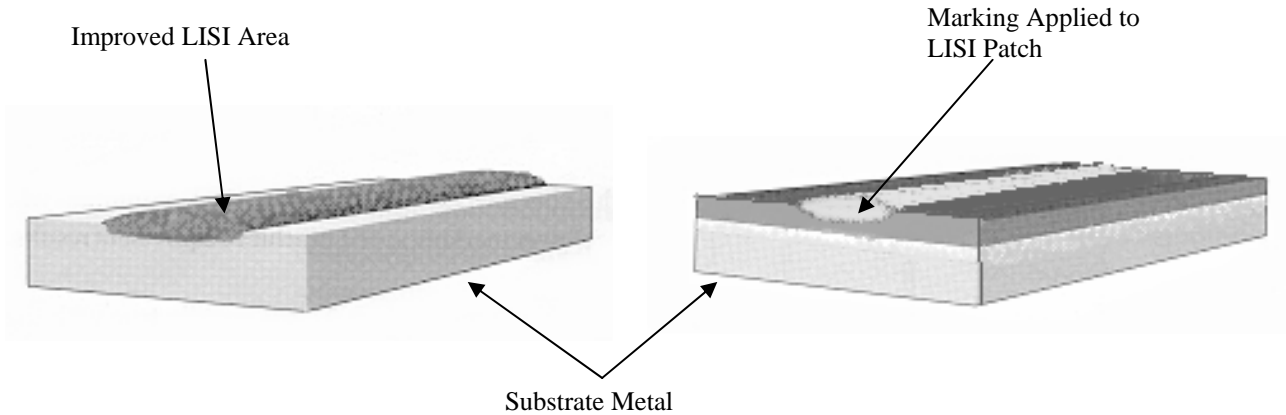

**Figure 34—LISI Marking Applied Directly to a Part Surface (left) and Applied to a LISI Patch (right)**

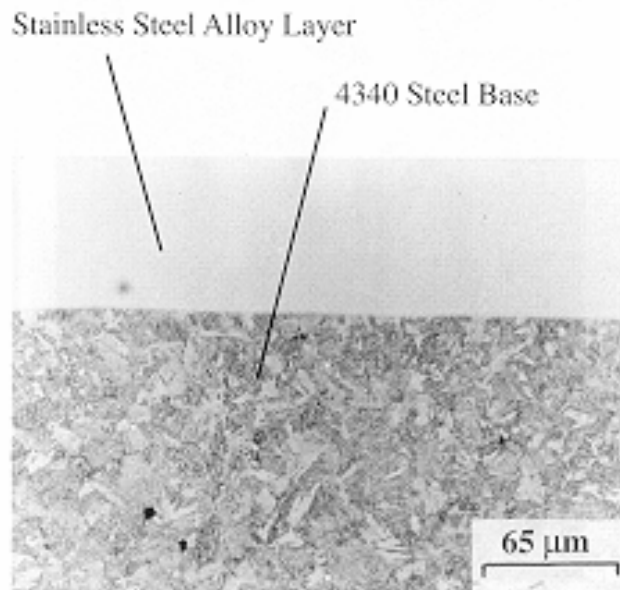

**Figure 35—Scanning Electron Microscope View of the LISI**

4.2.2.10 Gas-Assisted Laser Etch (GALE)

Ambient environment laser marking often results in a limited contrast between the engraved mark and the background on which it is placed, thus limiting the speed of the mark and the number of different materials that can be marked. The GALE technique can be used to mark an object in the presence of a selected gaseous environment, enhancing contrast and increasing readability. The mark is made using low-power settings, enabling it to be made with minimal laser interaction with the target material. GALE accomplishes this by the use of an assist gas that reacts with the material under the influence of the laser energy to produce a reactant that is a different reflective color from the background (see figure 36). The assist gases might be reducing, oxidizing, or even inert, their selection being dependent upon the target material. A

**APPROVED FOR PUBLIC RELEASE – DISTRIBUTION IS UNLIMITED**

## NASA-HDBK-6003C

contrasting surface results at the coincident point of the laser, gas, and material, producing a high-contrast, readable mark created in a controlled environment. Tests performed at the University of Tennessee Space Institute have demonstrated that the process should be safe for use in most aerospace marking applications.

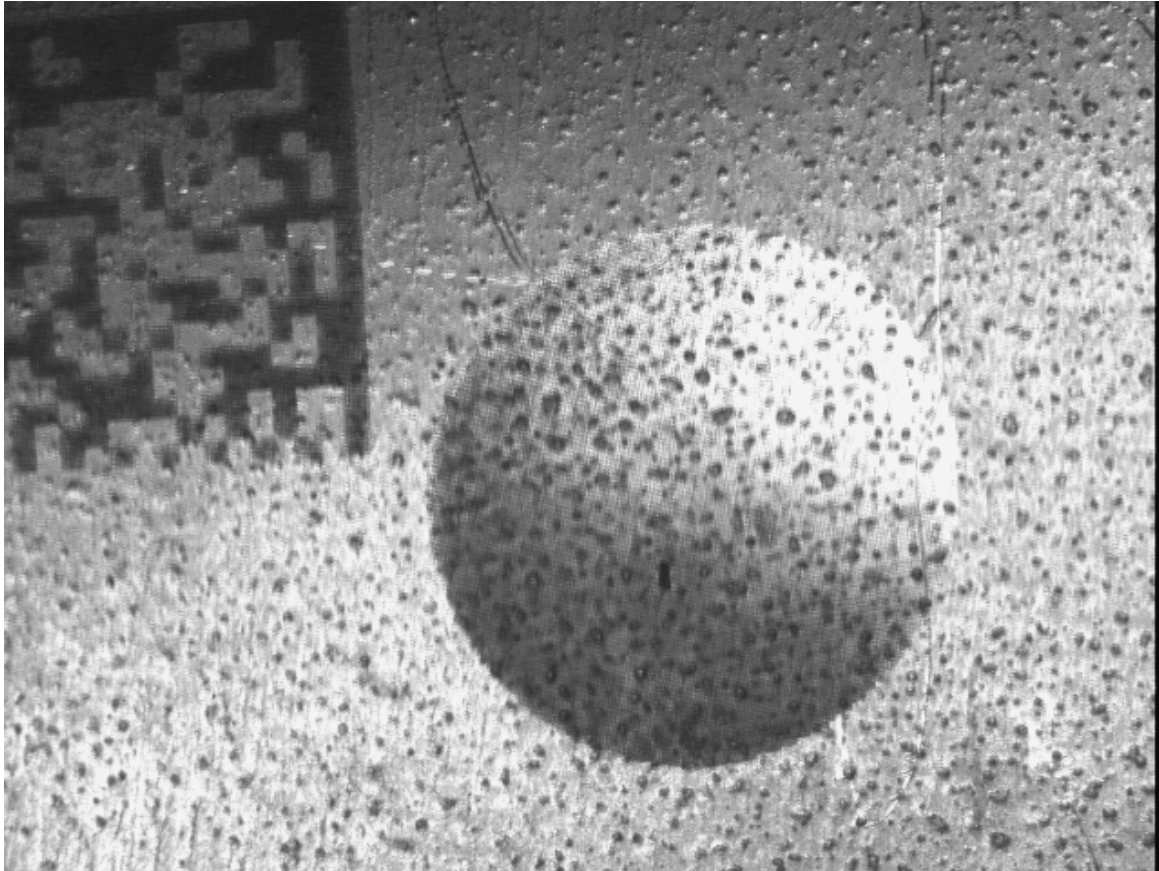

**Figure 36—View of Gas-Assisted Laser Etch Coating under Magnification**

**NOTE:** Surface protrusions are left intact after marking.

GALE is limited to metallic alloys.

### 4.2.2.11 Laser-Induced Vapor Deposition (LIVD)

Laser-induced vapor deposition is used to apply part identification markings, heating and defrosting strips, antennas, circuitry, and sun shields to transparent materials. This is accomplished by vaporizing material from a marking medium trapped under a transparent part using heat generated from a visible spectrum laser. The gaseous vapors and droplets resulting from the heat buildup condense on the cooler transparent surface to form a hard uniform coating that is applied in a prescribed pattern (figure 37). The process is accomplished under normal office conditions without the need for high heat or sealed gas/vacuum chambers. The marking materials (most metals) used to produce machine-readable symbols can be formulated to be read

**APPROVED FOR PUBLIC RELEASE – DISTRIBUTION IS UNLIMITED**

## NASA-HDBK-6003C

using both optical readers and sensing devices (e.g., x-ray, thermal imaging, ultrasound, magneto-optic, radar, capacitance, or other similar sensing means).



**Figure 37—Stainless Steel Marking Applied to Glass Slide Using LIVD Process**

Limitations of LIVD are provided below:

- Limited to transparent materials only
- Process limited to lasers operating in the visible spectrum

Table 4 provides a list of attributes associated with the various laser-marking processes described in this document.

**APPROVED FOR PUBLIC RELEASE – DISTRIBUTION IS UNLIMITED**

## NASA-HDBK-6003C

**Table 4—Laser Marking Process Comparison Table**

<b>Laser Marking Process Comparison</b>						
Marking Process	Attributes					
	Laser Type	Mark Power	Marking Speed	Marking Quality	Mark Durability	Removes Part Material
Laser Bonding	CO <sub>2</sub> , LVO4 and Nd:YAG	Low	Slow	Excellent	Good	No
Laser Coloration	Nd:YAG	Low	Slow	Excellent	<b>Excellent</b>	No
LENS	Nd:YAG					No
Laser Etching – Direct	Nd:YAG	Medium	Fast	Very Good	Excellent	Yes
Laser Etching – Coat and Mark	CO <sub>2</sub> , LVO4 and Nd:YAG	Low	Two-step process	Excellent	As durable as coating	No
Laser Engraving – Direct	Nd:YAG	Medium	Fast	Good	Excellent	Yes
Laser Engraving – Coat and Mark	Nd:YAG	Low	Two-step process	Excellent	As durable as coating	No
LISI	Nd:YAG	High	Slow	Good	Excellent	No*
Gas-assisted Laser Etch	LVO4 and Nd:YAG	Low	Slow	Very Good	Good	Minimal
LIVD	LVO4 and Nd:YAG	Low	Slow	Excellent	Good	No
Laser Shot-Peening	Nd:glass	High	Fast	Good	Excellent	No

\*Marked surface area has improved properties

### 4.3 Background

Recognizing that manual data collection and keyed data entry were inefficient and error-prone, NASA adopted bar codes in the mid-1980s to upgrade its operations. It soon became apparent that collecting the identity of the part from a symbol marked directly on it would be optimal. Bar codes were determined not to be suitable for DPM. NASA established a team to work with industry to develop and test machine-readable 2-D symbols designed to be applied to non-paper substrates. This five-year effort resulted in selection of the Data Matrix symbol for use in NASA applications and provided proof that 2-D symbols are reliable, and can be applied to most aerospace materials without impacting performance. NASA findings spurred additional testing by the Department of Defense (DoD) and private industry that resulted in selecting the Data Matrix symbol for parts marking by the AIM and the American National Standards Institute (ANSI). Additional part-marking standards quickly followed as the automotive, electronics, pharmaceutical, and aircraft industries adopted the symbol.

**APPROVED FOR PUBLIC RELEASE – DISTRIBUTION IS UNLIMITED**

## NASA-HDBK-6003C

These industries, including NASA, have relied heavily on the use of cast, forge, or mold, engraving; electrical arc pencil; electrical-chemical etch; embossing; hot stamp; rubber-ink stamp; stencil and silk screen; and vibration-etch for part identification marking. These marking methods, originally designed to apply human-readable markings, do not provide the fidelity needed to successfully apply high-density machine-readable symbols. Their manual operations also added to the large number of data transposition errors associated with paper-based manufacturing systems.

Understanding these weaknesses, the parts identification industry began to refine marking methods so they could be utilized to apply 2-D symbols. The manual metal stamp and embossing methods were replaced by dot-peen machines. Automated micro-profilers were designed to replace the manual cutting wheel used to produce paint stencils. Photo stencils and thermal-printing materials were developed to replace direct-impact electro-chemical marking stencil materials. Desktop publishing systems were developed for the production of stencils. Ink-jet machines were built to replace rubber stamps. Laser marking systems were designed to replace the electric-arc etch and hot-stamp processes. These methods and other new processes are described in this handbook.

This handbook and its related standard, NASA-STD-6002, were developed to provide NASA and its contractors with instructions to safely apply Data Matrix identification symbols to aerospace parts using these new DPM methods and techniques. Both the standard and the handbook were created by representatives from the major automatic identification and data capture (AI/DC) manufacturers, government and aerospace user groups under a collaborative agreement with NASA. The standard has been approved for use by NASA Headquarters and all field installations, and is intended to provide a common framework for consistent practices across NASA programs.

Revision B of this handbook included updates stemming from the DoD/National Center of Manufacturing Sciences (NCMS) Retrograde Part Marking Program as approved by the Assistant Under Secretary of Defense, and the United States Coast Guard (USCG) Data Matrix Direct Part Marking Flight Verification Program, which was sanctioned by the Flight Safety Critical Aircraft Part Problem Action Team (FSCAP PAT) and U. S. Congress Aircraft Safety Committee. Revision B planning was to include information from the Materials-International Space Station-Experiment (MISSE), which exposed Data Matrix Symbol markings to low earth orbit (LEO) environments. However, due to delays in the retrieval of the MISSE experiment, information related to marking processes certified for LEO is to be incorporated into a later revision of this document. MISSE program information is included in Appendix A.

**APPROVED FOR PUBLIC RELEASE – DISTRIBUTION IS UNLIMITED**

## NASA-HDBK-6003C

### 4.4 Key Word Listing

<u>Key Word</u>	<u>Page Number</u>
Configuration management	16
Data matrix	7, 8, 9, 11, 12, 13, 14, 16, 17, 18, 19, 22, 25, 27, 29, 35, 42, 44, 50, 56, 57, 59
Direct part marking	7, 9, 27, 57
License tag number	13
Machine-readable code	16
Part identification	16, 44, 54, 57
Part marking	7, 9, 17, 27, 57
Part tracking	4, 15
Protective coating	7, 42

**APPROVED FOR PUBLIC RELEASE – DISTRIBUTION IS UNLIMITED**

## NASA-HDBK-6003C

### APPENDIX A

#### MISSE PROGRAM INFORMATION

The Mission, International Space Station, Experiment (MISSE) was launched into low earth orbit on August 9, 2001, at 5:38 PM on the Space Shuttle Discovery (Mission STS-105). The experiment was attached to the exterior of the International Space Station by astronaut Patrick G. Forrester as part of an extravehicular activity (EVA), commonly called a spacewalk.

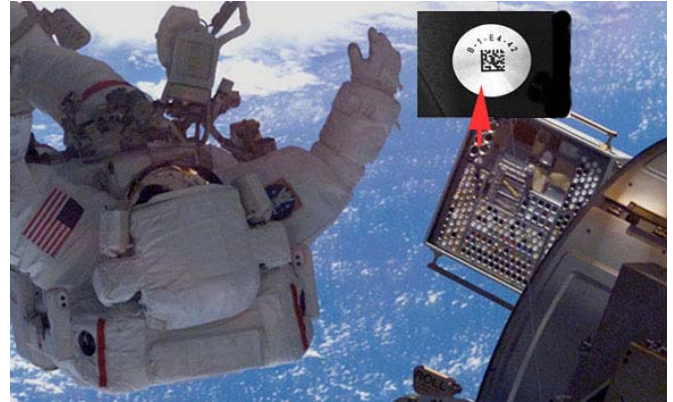

Included in the experiment trays are disks made of typical spacecraft materials that are marked with Data Matrix symbols using a wide range of marking processes. The trays are oriented to expose the disks to LEO environments. These include extreme levels of ultraviolet radiation, atomic oxygen, hard vacuum, and contamination, all of which have a strong degrading effect on some types of materials. Photographs of the markings taken after one year of exposure verify that the new processes are holding up well. Data obtained after retrieval is to be incorporated into table 5.

Qualifying materials for long-term use in space is especially challenging because this unique environment is so difficult to simulate in a laboratory. With MISSE, no laboratory is needed. On-orbit testing is accomplished by flying the materials outside the International Space Station for one to three years. The marked Data Matrix disks are installed in two Passive Experiment Containers (PECs). The two containers are scheduled to be retrieved during the second Space Shuttle mission following return to flight and are to be analyzed to determine the preferred marking sizes and processes to be used to apply part-identification markings on all future reusable spacecraft. Placeholders for this data have been incorporated into table 5.

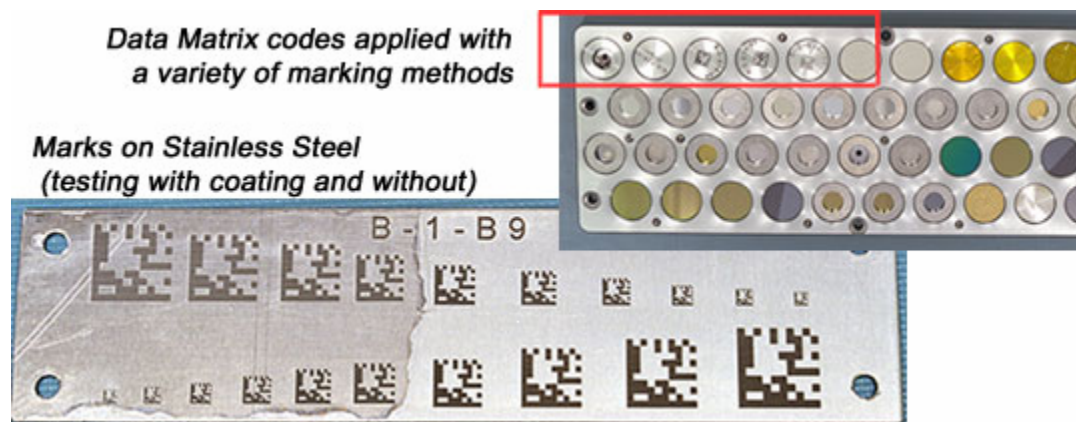

APPROVED FOR PUBLIC RELEASE – DISTRIBUTION IS UNLIMITED

## NASA-STD-6003B

### Table 5—MISSE Marking Sample Data

Specimen Number	Base Material	Marking Method	Marking Material	Encoded Info.	Planned Orbit Duration	Color of Mark	Initial Grade	Post-Flight Grade	Marking Equipment
B-1-E3-27	Glass	LIVD	Brass	Line Pattern	1 yr.	Dark Brown	Good Contrast		Rofin-Sinar Nd:YAG Laser
B-1-E3-28	Glass	LIVD	Tin	Line Pattern	1 yr.	Black	Good Contrast		Rofin-Sinar Nd:YAG Laser
B-1-E3-29	Glass	Laser Bonding	Cerdec RD-6005	Line Pattern	1 yr.	Gray-Black	Excellent Contrast		Rofin-Sinar Nd:YAG Laser
B-1-E3-30	Glass	VAVD	Copper	Line Pattern	1 yr.	Dark Gray	Good Contrast		Rofin-Sinar Nd:YAG Laser
B-1-E3-31	Glass	LIVD	Tin	B1E331	1 yr.	Black	A		Rofin-Sinar Nd:YAG Laser
B-1-E10-03	Glass	LIVD	Brass	Line Pattern	1 yr.	Dark Brown	Good Contrast		Rofin-Sinar Nd:YAG Laser
B-1-E10-04	Glass	LIVD	Tin	Line Pattern	1 yr.	Black	Good Contrast		Rofin-Sinar Nd:YAG Laser
B-1-E10-05	Glass	Laser Bonding	Cerdec RD-6005	Line Pattern	1 yr.	Gray-Black	Excellent Contrast		Rofin-Sinar Nd:YAG Laser
B-1-E10-06	Glass	VAVD	Copper	Line Pattern	1 yr.	Dark Gray	Good Contrast		Rofin-Sinar Nd:YAG Laser
B-1-E10-07	Glass	LIVD	Brass	B1E107	1 yr.	Dark Brown	A		Rofin-Sinar Nd:YAG Laser

**NASA-STD-6003B**

**Table 5—MISSE Marking Sample Data (continued)**

Specimen Number	Base Material	Marking Method	Marking Material	Encoded Info.	Planned Orbit Duration	Color of Mark	Initial Grade	Post Flight Grade	Marking Equipment
B-1-E4-42	Aluminum	Laser Bonding	Cerdec RD-6000	B1E442	1 yr.	Black	A		Rofin-Sinar Nd:YAG Laser
B-1-E4-43	Glass	Laser Bonding	Cerdec RD-6005	B1E443	1 yr.	Black	A		Rofin-Sinar Nd:YAG Laser
B-1-E4-44	Aluminum	VAVD	Copper	B1E444	1 yr.	White	A		Rofin-Sinar Nd:YAG Laser
B-1-E4-45	Aluminum	GALE	Argon Gas	CiMatx	1 yr.	Dark Gray	A		LMT Diode-Pumped Laser
B-1-E4-46	Aluminum	Chemical Etching	SCE-4	B1E446	1 yr.	Gray	A		Electro-Chem Etch Machine
B-2-E16-42	Aluminum	Dot Peen	N/A	2E1642	3 yrs.	White	A		Telesis TMP 6000 Pinstamp
B-2-E16-43	Aluminum	Laser Etching	N/A	2E1643	3 yrs.	Dark Gray	A		Rofin-Sinar Nd:YAG Laser
B-2-E16-44	Aluminum	LISI	Metallic Powders	2E1644	3 yrs.	Dark Gray	A		Rofin-Sinar Nd:YAG Laser
B-2-E16-45	Aluminum	Laser Shot-Peening	N/A	2E1645	3 yrs.	White	B		Neodymium-Doped glass Laser
B-2-E16-46	7980 Glass (Corning)	LIVD	Tin	2E1646	3 yrs.	Black	A		Rofin-Sinar Nd:YAG Laser
B-1-B9	Aluminum Plate	Laser Etching	N/A	123456	3 yrs.	Gray	A		Rofin-Sinar Nd:YAG Laser