

NASA Contractor Report 181650

CODAC
(Cockpit Oriented Display of Aircraft Configurations)
Version 1.4 User's Guide

(NASA-CR-181650) CODAC (COCKPIT ORIENTED
DISPLAY OF AIRCRAFT CONFIGURATIONS) VERSION
1.4 USER'S GUIDE (Computer Sciences Corp.)
65 p C S C L 0 1 A

N88-20273

Unclas
0135280

G3/02

Bradford D. Bingel, Erma L. Wilson and Michelle S. Hollis

Computer Sciences Corporation
Applied Technology Division
Hampton, VA 23666-1379

Contract NAS1-17999

January 1988

NASA

National Aeronautics and
Space Administration

Langley Research Center
Hampton, Virginia 23665-5225

Preface

This document describes CODAC, the Cockpit Oriented Display of Aircraft Configurations graphics program, version 1.4. All users should be familiar with their host computer, its operating system, and their particular graphics terminal. Those users wishing to use CODAC's hardcopy features should also be familiar with DI-3000 metafiles and their computer installation's graphic postprocessing facilities.

The current version of CODAC executes under CDC NOS 2.4.3 and CDC NOS/VE 1.2.1. Both installations use Precision Visuals' DI-3000 graphics package, version 4 or 5. The entire program is written in ANSI FORTRAN 77, and all graphics utilities are drawn from the standard DI-3000 graphics library.

Revision Record

<u>Date</u>	<u>Release</u>
10/84	CODAC version 1.0 (original release)
1/86	CODAC version 1.1A (complete revision)
7/87	CODAC version 1.3 (complete revision)
1/88	CODAC version 1.4 (complete revision)

Table of Contents

1. Introduction	1-1
General Description	1-1
List of Features	1-1
2. Interactive Use	2-1
Files	2-1
Execution	2-1
Geometry File Name and Format	2-3
Axis Orientation	2-3
Object Rotation	2-4
Scale Factor, Viewing Distance, and Perspective	2-5
Framing	2-6
Angle Display	2-6
Plotting	2-7
Metafiles	2-7
Dialog Loop	2-8
3. Batch Use	3-1
4. Metafile/Hardcopy Postprocessing	4-1
Concept of Metafiles	4-1
Editing Images	4-2
Requesting Hardcopies	4-3
Appendix A - Sample Interactive Sessions	
Appendix B - Sample Batch Jobs	
References	

Section 1

Introduction

General Description

CODAC (Cockpit Oriented Display of Aircraft Configurations) is an interactive graphics program used to display three-dimensional objects. It was originally developed at NASA Langley Research Center as a way to quickly display aircraft configurations described in any one of a variety of geometry definition formats.

There are two software sections within CODAC: a hidden-line package, and a user dialog package.

The hidden-line package was developed by David R. Hedgley, Jr., of NASA's Dryden Flight Research Facility [Hedgley,1982]. This package is noteworthy for two reasons. First, it solves the hidden-line problem in the general sense, meaning that the object may be viewed from any angle, with or without perspective, resulting in high-quality, publication-grade images. Second, the package performs these functions in a fraction of the time required by other comparable packages. Versions of this package presently exist for Calcomp, Tektronix Plot 10, and DI-3000 applications.

The user dialog package was developed by Computer Sciences Corporation, under contract to NASA Langley Research Center. It has two purposes. First, Hedgley's hidden-line package is a collection of FORTRAN subroutines, not a stand-alone program. The user dialog package functions as its executive, providing the necessary information, and handling the resulting graphics. Second, the dialog package includes many additional features which make creating an image much easier than if a simpler program ran the hidden-line routines.

The current version of CODAC executes under CDC NOS 2.4.3 and CDC NOS/VE 1.2.1. Both installations use Precision Visuals' DI-3000 graphics package. Installing CODAC on other systems is a relatively simple process because it is written in ANSI FORTRAN 77 and all graphics utilities are drawn from the standard DI-3000 graphics library [PVI,1984]. A separate document, the "CODAC 1.4 Installation Guide", is highly recommended.

List of Features

Quick, High-Quality Images

First and foremost, CODAC was designed to quickly create realistic images of three-dimensional objects. It is relatively fast when compared to similar packages, and produces high-quality, publication-grade hardcopies.

Axis Orientation

Rather than have the user work with a fixed axis system, CODAC conforms to fit the object's axis system. This makes it easier for the user to visualize the three-dimensional workspace and position the object for the desired view.

Yaw, Roll, and Pitch

Similarly, rather than have the user work with fixed directions of rotation, CODAC accepts the aircraft directions yaw, roll, and pitch. For example, rather than ask for a rotation of -45 degrees around the Z-axis, the user asks the object to yaw left 45 degrees. This gives CODAC the name "Cockpit Oriented", since each rotation is performed as if the user is sitting in the cockpit of the aircraft. In addition, any or all rotations may be requested, and in any order.

Automatic Scaling

If desired, CODAC automatically scales each image it creates to fit on the terminal screen. The user may turn this option off anytime during the interactive session and take manual control.

Geometry File Formats

CODAC accepts five geometry file formats: Langley Wireframe Geometry Standard (LaWGS), Craidon (1983 LaWGS), Free Vortex Sheet (FVS) Data Check, Hess, and Integrated Aerodynamic Analysis System (IAAS) General Geometry (GG). Additional formats, such as Hypersonic Arbitrary Body, Carlson/Harris Wave Drag, CDS wireframe, and PAN AIR, may be available in future releases.

Automatic Formats

Given a geometry file, CODAC automatically recognizes any of the formats listed above, and processes it accordingly.

DI-3000 Metafiles

CODAC makes full use of the DI-3000 metafile option, which offers two benefits. First, images written onto metafiles are easily transformed into hardcopies on a variety of graphics postprocessing devices. Second, the DI-3000 metafile translator (a utility usually available along with the DI-3000 library) lets the user edit images stored in a metafile. For example, the user may selectively extract images from a metafile, scale or translate them, or even superimpose them on top of other images, then save these new images on a new metafile.

Section 2

Interactive Use

Files

The user is responsible for ensuring that the geometry file(s) CODAC uses are available, and that any files CODAC writes are retained.

Under NOS 2 a typical command sequence is:

GET,F106.	makes geometry file "F106" available
(CODAC execution)	
SAVE,META1,META2.	retains two metafiles

Under NOS/VE a typical command sequence is:

ATTF F106	makes geometry file "F106" available
(CODAC execution)	
COPF \$LOCAL.META1 META1	
COPF \$LOCAL.META2 META2	retains two metafiles

Other operating systems will have different command sequences.

Execution

CODAC's execution sequence depends on its host's operating system.

At NASA/Langley under NOS 2 the commands are:

```
GET,CODAC/UN=NTFLIB.  
CODAC.
```

the first of two menus appears:

Terminal Menu:

1104.	Sieko 1104
4014.	Tektronix 4014
4105.	Tektronix 4105
4107.	Tektronix 4107
4109.	Tektronix 4109
4115.	Tektronix 4115

Which Terminal are You Using ?

For example, if you are using a Tektronix 4109 terminal, enter **4109**; if you are using a Seiko 1104, enter **1104**; and so on.

The second menu appears:

Capacity Menu:

100.	100 or fewer panels
1000.	1000 or fewer panels
1400.	1400 or fewer panels

How Many Panels Does Your Geometry Have ?

If your geometry file defines 100 or fewer panels, enter **100**. If it defines 1000 or fewer panels, enter **1000**. If it defines 1400 or fewer panels, enter **1400**. If you don't know how many panels it defines, enter **1400** (the maximum capacity).

At NASA/Langley under NOS/VE the commands are:

```
SETCL A=$FAMILY.NTFLIB.PROCS  
CODAC
```

The first of two menus appears:

The available device drivers are:

TEK4105	Tektronix 4105
TEK4107	Tektronix 4107
TEK4109	Tektronix 4109
TEK4115	Tektronix 4115

Which Terminal are You Using ?

For example, if you are using a Tektronix 4109 terminal, enter **TEK4109**; if you are using a Tektronix 4115 terminal, enter **TEK4115**; and so on.

The second menu appears:

The available panel capacities are:

SMALL	100 or fewer panels
MEDIUM	1,000 or fewer panels
LARGE	10,000 or fewer panels

How Many Panels Does Your Geometry Have ?

If your geometry file defines 100 or fewer panels, enter **100** or **SMALL**. If it defines 1000 or fewer panels, enter **1000** or **MEDIUM**. If it defines 10,000 or fewer panels, enter **10,000** or **LARGE**.

Whatever the host operating system, the following welcome banner then appears:

CODAC
COCKPIT ORIENTED DISPLAY OF AIRCRAFT CONFIGURATIONS
VERSION 1.4 JANUARY 1988

Note that the version number and date will change as new versions of CODAC are released.

Geometry File Name and Format

The first prompt is:

ENTER THE NAME OF THE FILE CONTAINING YOUR GEOMETRY:

You must enter a file name - CODAC cannot use a default file if you only press the RETURN key. The name you specify must be valid for the host operating system. If it is not, CODAC writes an error message, and asks for another file name. The file also must be available. If it is not, or if the file doesn't exist, CODAC writes an error message, and asks for another file name.

After a satisfactory file name is entered, CODAC attempts to match its contents with a recognized geometry file format. If a match is made, CODAC names the format used. If the file's format is not recognized, CODAC writes an error message and returns back to the previous question asking for a file name.

If you wish to stop CODAC, enter **END**, **STOP**, or **QUIT**.

Axis Orientation

"Axis Orientation" refers to the three-dimensional environment of the object described in the geometry file. In other words, how are the X, Y, and Z axes arranged relative to the object? CODAC must have this information before it can correctly manipulate the object. The prompt is:

WHEN IT WAS CREATED, THIS MODEL HAD A SPECIFIC
X/Y/Z AXIS ORIENTATION. AS IF YOU WERE SITTING IN
THE COCKPIT, ENTER THE DIRECTION AND AXIS NAME FOR
THREE DIRECTIONS: FORWARD, TO THE RIGHT, AND UP.
FOR EXAMPLE, "-X,+Y,+Z" INDICATES THAT X DECREASES
MOVING FORWARD, Y INCREASES MOVING TO THE RIGHT,
AND Z INCREASES MOVING UP.

THE MODEL ORIENTATION "-X+Y+Z" WILL BE ASSUMED
IF YOU SIMPLY PRESS THE "RETURN" KEY.

For example, the response:

-X +Y +Z

tells CODAC that "forward" corresponds to a negative change in X ("-X"), "to the right" corresponds to a positive change in Y ("+Y"), and "up" corresponds to a positive change in Z ("+Z").

The response:

+Y,-Z -X

tells CODAC that "forward" corresponds to a positive change in Y ("+Y"), "to the right" corresponds to a negative change in Z ("-Z"), and "up" corresponds to a negative change in X ("-X").

There are some guidelines for entering the orientation. First, all three axes (X, Y, and Z) must be specified. Second, each axis must have a sign (+ or -) preceding it. Third, the axes in the list can be separated by blanks, commas, or no separator at all. For example, the responses:

+Z-X-Y
+Z,-X,-Y
+Z -X,-Y
+Z, -X-Y
+Z-X,-Y

are all valid and all refer to the same orientation.

If you wish to stop CODAC, enter **END**, **STOP**, or **QUIT**.

Object Rotation

The next prompt is:

**ENTER THE YAW, ROLL, AND/OR PITCH ANGLES:
(IF YOU PRESS ONLY THE "RETURN" KEY
THE ANGLES 'YR120 RR20' WILL BE USED.)**

For example, the response:

YL45 PU30

asks CODAC to perform a yaw to the left ("YL") 45 degrees, then pitch up ("PU") 30 degrees. Yaw is specified with the prefixes "YL" and "YR", corresponding to "yaw left" and "yaw right", respectively. Roll is specified with the prefixes "RL" and "RR", corresponding to "roll left" and "roll right", respectively. Pitch is specified with the prefixes "PD" and "PU", corresponding to "pitch down" and "pitch up", respectively. For example, the response:

PU15 YR150 RR10

asks CODAC to perform a "pitch up" of 15 degrees, a "yaw right" of 150 degrees, and a "roll right" of 10 degrees. Each rotation request begins with the cockpit facing forward and the viewer directly behind the object.

There are some guidelines for entering the rotations. First, any or all rotations may be entered, and in any order. Second, each rotation entered is expected to have its angle of rotation in degrees. Angles less than -360 or greater than +360 are subjected to a modulus function (e.g., "YR380" is converted into "YR20"). Third, all rotations in the list are separated by blanks or commas. For example, the responses:

YL165 PD10 RL30
YL165, PD10, RL30
YL165 PD10, RL30

are all valid and all refer to the same rotations.

If you wish to stop CODAC, enter **END**, **STOP**, or **QUIT**.

Scale Factor, Viewing Distance, and Perspective

The next prompt is:

ENTER THE SCALE FACTOR AND VIEWING DISTANCE,
OR ENTER "AUTO" FOR AUTOMATIC SCALING WITH
A SLIGHT PERSPECTIVE.
(IF YOU PRESS ONLY THE "RETURN" KEY THE RESPONSE
"AUTO" WILL BE ASSUMED)

For example, the response:

AUTO

selects the automatic scaling option. The image is scaled to fit on your terminal's screen and will have a slight perspective. Use of the auto-scale option is highly recommended.

You also have the option of using a manual scale factor and viewing distance. For example:

30,99999

asks for a scale factor of 30 and a viewing distance of 99999.

The scale factor and viewing distance control the image's final appearance. The scale factor sets the number of object units mapped into each screen unit. Thus a small scale factor produces a large image, and a large scale factor produces a small image. The viewing distance controls the amount of perspective in the image. A small viewing distance moves the "eye" closer to the object, increasing perspective. A large viewing distance moves the "eye" away from the object, decreasing perspective. A very large viewing distance (like 99999) produces a parallel projection (no perspective).

The scale factor and viewing distance operate independently. Image size is controlled only by the scale factor. Image perspective is controlled only by the viewing distance.

You may wish to change only one item of the pair. For example, the response:

45

sets the scale factor to 45, but leaves the viewing distance unchanged (its previous value is retained).

The response:

,5000

leaves the scale factor unchanged (its previous value is retained) but sets the viewing distance to 5000. If both items are entered, they are separated by a blank or a comma. For example, the responses:

45,5000
45 5000
45 5000
45 , 5000

are all valid and equivalent.

Note

Viewing distance is measured from the object's origin (0,0,0). If the yaw/roll/pitch entry and viewing distance entry place the vantage point (or "eye") inside, on, or extremely close to the object, CODAC may not draw an image, or may draw a very distorted image.

If you wish to stop CODAC, enter **END, STOP, or QUIT.**

Framing

The next prompt is:

**DO YOU WANT THE IMAGE FRAMED?
(IF YOU PRESS ONLY THE "RETURN" KEY
A FRAME WILL NOT BE DRAWN.)**

If you press only the RETURN key, or enter **N** or **NO**, the next image is not framed with a rectangle. If you enter **Y** or **YES**, it is framed.

If you wish to stop CODAC, enter **END, STOP, or QUIT.**

Angle Display

The next prompt is:

**DO YOU WANT THE ANGLES DISPLAYED ABOVE THE IMAGE?
(IF YOU PRESS ONLY THE "RETURN" KEY
THE ANGLES WILL NOT BE DISPLAYED)**

If you press only the RETURN key, or enter **N** or **NO**, the rotation angles will not be displayed. If you enter **Y** or **YES**, they will be displayed.

If you wish to stop CODAC, enter **END, STOP, or QUIT.**

Plotting

Immediately after you answer the above question, CODAC clears the screen and draws the requested image. Depending on the complexity of the object, and on how many other users are sharing your computer, drawing the image may take less than a minute or up to 10 minutes (for a faster response, try using CODAC early in the morning or during lunchtime, when the system load is generally lower).

CODAC may pause a number of times before the image is completed. DO NOT request system status information (escape E under CDC NOS) or change your terminal characteristics while CODAC is drawing - the action may remove the terminal from graphics mode and fill the terminal screen with gibberish.

When it is finished drawing an image CODAC activates the crosshair/joystick cursor. If this cursor interferes in seeing the object it can be moved by using the terminal's thumbwheels, joystick, or joydisc. Be careful to keep the crosshair cursor on the screen (perhaps tucked away in a corner), as positioning it off the screen may confuse the DI-3000 device driver and lead to unpredictable graphic operations.

Until you enter the command to continue, CODAC remains suspended. This is the time to make a local working hardcopy, or figure out what changes are needed to obtain a better image. To have CODAC resume processing, press the space bar. CODAC immediately clears the terminal screen, and continues with the next series of questions.

Metafiles

A "metafile" is a special file used by the DI-3000 graphics package to store one or more graphic images. For a full discussion on metafiles and making hardcopies, see section 4.

The next prompt is:

DO YOU WANT THE IMAGE SAVED IN A METAFILE?
(IF YOU PRESS ONLY THE "RETURN" KEY
THE IMAGE WILL NOT BE SAVED.)

If you press only the RETURN key, or enter **N** or **NO**, the preceding image is not saved in a metafile. If you enter **Y** or **YES**, it is saved in a metafile.

If you wish to stop CODAC, enter **END**, **STOP**, or **QUIT**.

If you answer **YES**, the next prompt will be:

ENTER THE NAME OF THE METAFILE TO BE CREATED:
(IF YOU PRESS ONLY THE "RETURN" KEY
THE METAFILE "MF1" WILL BE USED.)

If you press only the RETURN key, metafile MF1 is created and the previous image is saved in it. If you provide a file name, it is created and the preceding image is saved in it. If the file name you specify is invalid for the host operating system, or if the file already exists, CODAC writes an error message and asks for another name.

If you wish to stop CODAC, enter **END**, **STOP**, or **QUIT**.

Once you save an image in a metafile, subsequent prompts become:

ENTER THE NAME OF THE METAFILE TO BE USED.
(IF YOU PRESS ONLY THE "RETURN" KEY
THE METAFILE "mfname" WILL CONTINUE TO BE USED.)

where "mfname" is the name of the metafile currently in use.

If you only press the RETURN key, the metafile currently open continues to be used (subsequent images are appended to the metafile after the last saved image). If you enter a new file name, the previous metafile is closed, a new metafile is opened, and the preceding image is saved in it. If the file name you specify is invalid for the host operating system, or if the file already exists (as a metafile or not), CODAC writes a warning message and asks for another metafile name.

A multiple image metafile is created only when a sequence of images is saved while the same metafile remains open and in use. Once you close a metafile, CODAC cannot re-open it and append subsequent images at its end.

Dialog Loop

Once you complete the metafile prompt(s), CODAC clears the terminal screen and cycles back to the object rotation (yaw/roll/pitch) prompt. A simple diagram of this dialog loop is shown in figure 2-1.

CODAC continues to cycle the dialog loop until you specifically ask to stop. Notice that you may stop CODAC at any prompt by entering **END**, **STOP**, or **QUIT**.

Section 3

Batch Use

Executing CODAC in batch mode is similar to using it interactively, with the following exceptions:

All responses to CODAC's questions should be contained in the batch job's command stream. Also, you must include a "QUIT", "STOP", or "END" as the last directive.

For those questions which accept only a carriage return ("if you press only the RETURN key") a blank line (i.e., a line actually containing one or more blanks) in your batch input stream performs the same function. Note that an empty line or null line may not be the same as a blank line. To be safe, use a blank line.

Interactively, CODAC pauses after drawing an image, and you must press the space bar to continue. This does not occur in batch mode. Your batch input stream must not contain any responses between your responses to the question about displaying the rotation angles and the question about wanting to save the image on a metafile.

A sample CDC/NOS batch job to execute CODAC in batch mode is shown as example #1 in Appendix B.

Section 4

Metafile/Hardcopy Postprocessing

Concept of Metafiles

When CODAC draws an image on your terminal screen, two distinct steps are performed. First, the DI-3000 library routines create a set of graphics instructions. Second, these instructions are interpreted by a device driver and the results are displayed on your terminal screen (see figure 4-1).

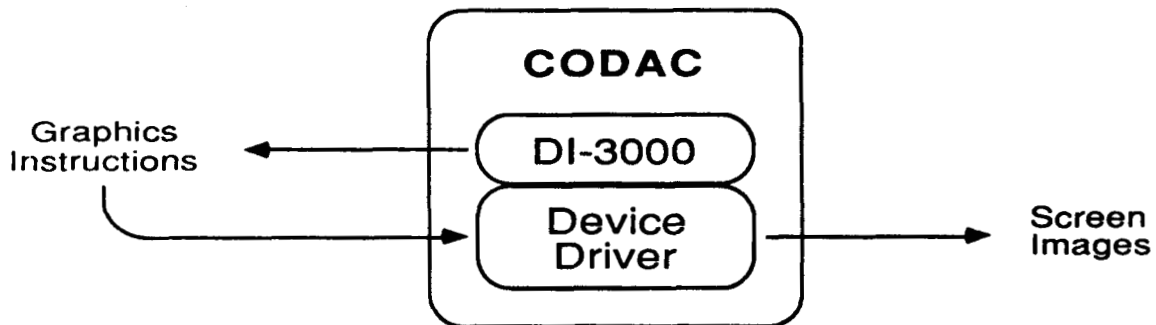

Figure 4-1.

In addition to screen images, you may wish to save these graphics instructions for creating high quality hardcopies. These instructions can be processed by the metafile driver and written to a metafile (see figure 4-2).

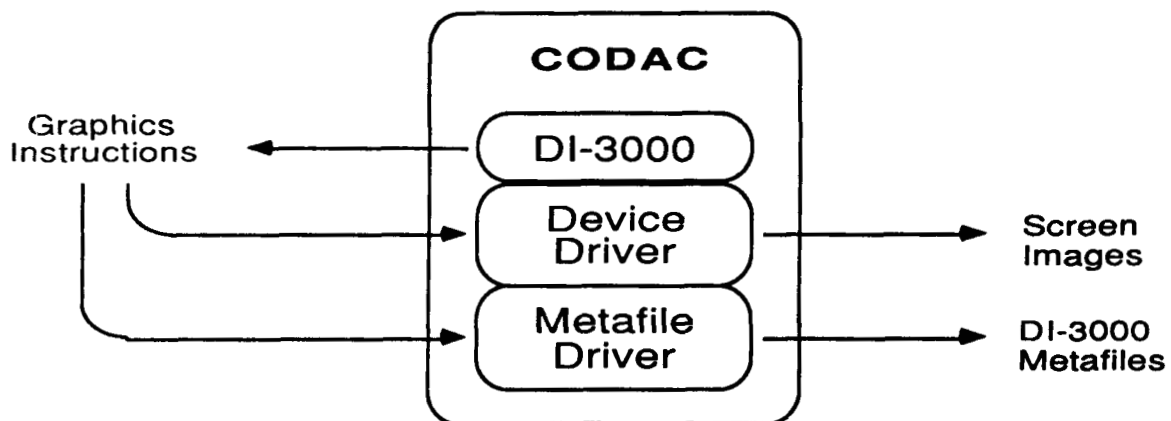

Figure 4-2.

Thus a metafile is a file containing DI-3000 graphics instructions.

Editing Images

Once you have a metafile containing your images, you can use the Metafile Translator to perform any desired editing (see figure 4-3).

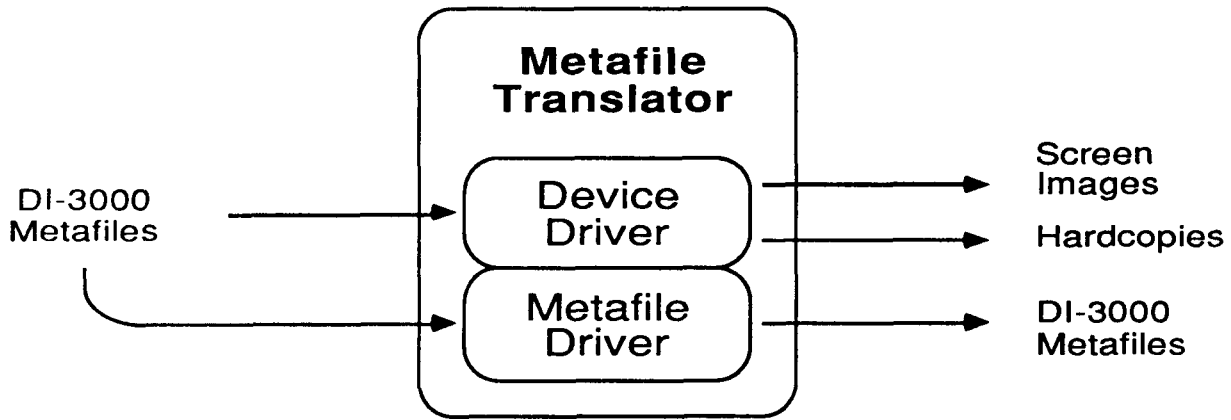

Figure 4-3.

Using the Metafile Translator, you can perform any of the following functions:

- Display all images saved in a metafile.
- Display select images from a single metafile or many metafiles.
- Position and scale images.
- Create a new metafile and store any sequence of images.
- Superimpose or otherwise combine many images (even from different metafiles) into a single new image, and optionally store it into a new metafile.

For a full description of the Metafile Translator, including an excellent tutorial, refer to the "Metafile System User's Guide" [PVI,1984].

Under NOS 2 the Metafile Translator execution sequence is:

```
GET, MFEDIT/UN=NTFLIB
MFEDIT, device
```

where "device" is the device name of your graphics terminal (**4014** for a Tektronix 4014, **512** for an AED 512, etc.).

Under NOS/VE the execution sequence is:

```
SETCL $FAMILY.NTFLIB.PROCS      (if not already set)
MFEDIT device
```

where "device" is the device name of your graphics terminal (**TEK4105** for a Tektronix 4105, **TEK4115** for a Tektronix 4115, etc.).

For a detailed discussion of running DI-3000 software under NOS/VE, refer to the Software Release Bulletin, PVI Products, for NOS/VE [CDC,1987].

Requesting Hardcopies

The metafiles you create using CODAC can be processed directly by a variety of graphic devices. Users at NASA/LaRC may obtain a list of the available devices and instructions for their use in NASA Technical Memorandum 87622 [Taylor,1985]. A sample CDC/NOS batch job to obtain an 11 inch Calcomp hardcopy is shown as example #3 in Appendix B. Other installations will have different procedures.

If you are using NOS/VE you may or may not have plotting devices available. If not, the metafile may have to be transferred to an appropriate operating system. For example, NASA/LaRC has no graphic postprocessing devices available directly from NOS/VE, and all metafiles must be transferred to a mainframe running NOS.

CODAC's metafiles are 32-bit (high precision) formatted files, permitting them to be transferred across most communication networks. If you are using NOS/VE on dual state machine, the NOS/VE transfer command is:

```
REPF vename nosname DC=A6
```

where "vename" is the name of the metafile on NOS/VE and "nosname" is the name of the metafile to be created under NOS. Remember that if the NOS file you specify doesn't already exist, NOS/VE will create it as direct access.

Appendix A

Sample Interactive Sessions

Sample Session #1

**/GET,CODAC,AGDEMO/UN=NTFLIB
/CODAC**

Terminal Menu:

512.	AED 512
1104.	Sieko 1104
4014.	Tektronix 4014
4105.	Tektronix 4105
4107.	Tektronix 4107
4109.	Tektronix 4109
4115.	Tektronix 4115

Which Terminal are You Using ? **4109**

Capacity Menu:

100.	100 or fewer panels
1000.	1000 or fewer panels
1400.	1400 or fewer panels

How Many Panels Does Your Geometry Have ? **1000**

Sample Session #1 - continued

CODAC

COCKPIT ORIENTED DISPLAY OF AIRCRAFT CONFIGURATIONS

VERSION 1.4 JANUARY 1988

ENTER THE NAME OF THE FILE CONTAINING YOUR GEOMETRY:

? **AGDEMO**

THIS GEOMETRY FILE IS IN CRAIDON FORMAT
AND HAS BEEN READ AND VERIFIED.

WHEN IT WAS CREATED, THIS MODEL HAD A SPECIFIC
X/Y/Z/ AXIS ORIENTATION. AS IF YOU WERE SITTING IN
THE COCKPIT, ENTER THE DIRECTION AND AXIS NAME FOR
THREE DIRECTIONS: FORWARD, TO THE RIGHT, AND UP.
FOR EXAMPLE, "-X,+Y,+Z" INDICATES THAT X DECREASES
MOVING FORWARD, Y INCREASES MOVING TO THE RIGHT,
AND Z INCREASES MOVING UP.

THE MODEL ORIENTATION "-X+Y+Z" WILL BE ASSUMED
IF YOU SIMPLY PRESS THE "RETURN" KEY.

? **+X+Y+Z**

REQUESTED ORIENTATION: "+X+Y+Z" .

ENTER THE YAW, ROLL, AND/OR PITCH ANGLES.
(IF YOU PRESS ONLY THE "RETURN" KEY, THE ANGLES
"YR120 RR20" WILL BE USED.)

? **PU90**

ENTER THE SCALE FACTOR AND VIEWING DISTANCE,
OR ENTER "AUTO" FOR AUTOMATIC SCALING WITH
A SLIGHT PERSPECTIVE.
(IF YOU PRESS ONLY THE "RETURN" KEY THE RESPONSE
"AUTO" WILL BE ASSUMED.)

? **AUTO**

Sample Session #1 - continued

A REMINDER: WHEN YOU FINISH VIEWING THE PLOT ---
--- PRESS THE SPACE BAR, NOT THE "RETURN" KEY.

DO YOU WANT THE IMAGE FRAMED?
(IF YOU PRESS ONLY THE "RETURN" KEY,
A FRAME WILL NOT BE DRAWN.)

? YES

DO YOU WANT THE ANGLES DISPLAYED WITH THE IMAGE?
IF YOU PRESS ONLY THE "RETURN" KEY,
THE ANGLES WILL NOT BE DISPLAYED.

? YES

Sample Session #1 - continued

PITCH UP 90

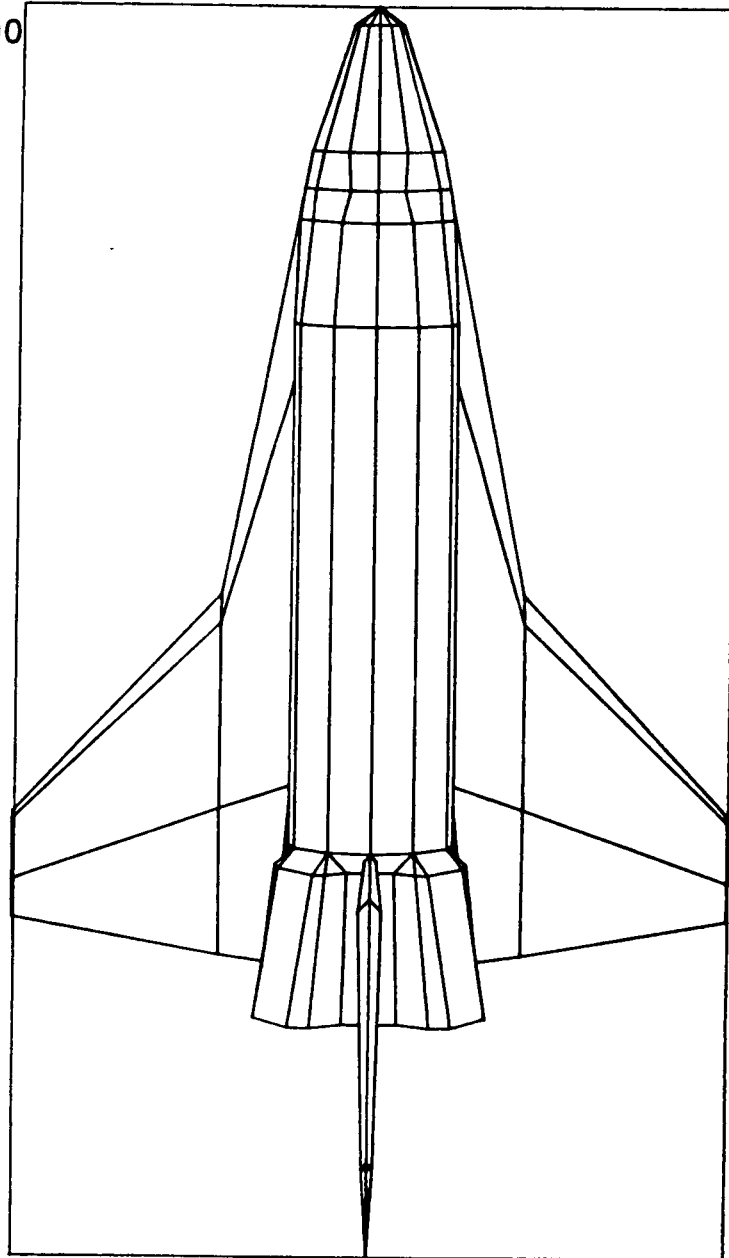

Sample Session #1 - continued

DO YOU WANT THE IMAGE SAVED IN A METAFILE ?
IF YOU PRESS ONLY THE "RETURN" KEY,
THE IMAGE WILL NOT BE SAVED.

? NO

ENTER THE YAW, ROLL, AND/OR PITCH ANGLES.
(IF YOU PRESS ONLY THE "RETURN" KEY, THE ANGLES
"PU90" WILL BE USED.)

? YR90 RR90

ENTER THE SCALE FACTOR AND VIEWING DISTANCE,
OR ENTER "AUTO" FOR AUTOMATIC SCALING WITH
A SLIGHT PERSPECTIVE.
(IF YOU PRESS ONLY THE "RETURN" KEY THE RESPONSE
"AUTO" WILL BE ASSUMED.)

? *(carriage return)*

A REMINDER: WHEN YOU FINISH VIEWING THE PLOT ---
--- PRESS THE SPACE BAR, NOT THE "RETURN" KEY.

DO YOU WANT THE IMAGE FRAMED?
(IF YOU PRESS ONLY THE "RETURN" KEY,
A FRAME WILL NOT BE DRAWN.)

? NO

DO YOU WANT THE ANGLES DISPLAYED WITH THE IMAGE?
IF YOU PRESS ONLY THE "RETURN" KEY,
THE ANGLES WILL NOT BE DISPLAYED.

? NO

Sample Session #1 - continued

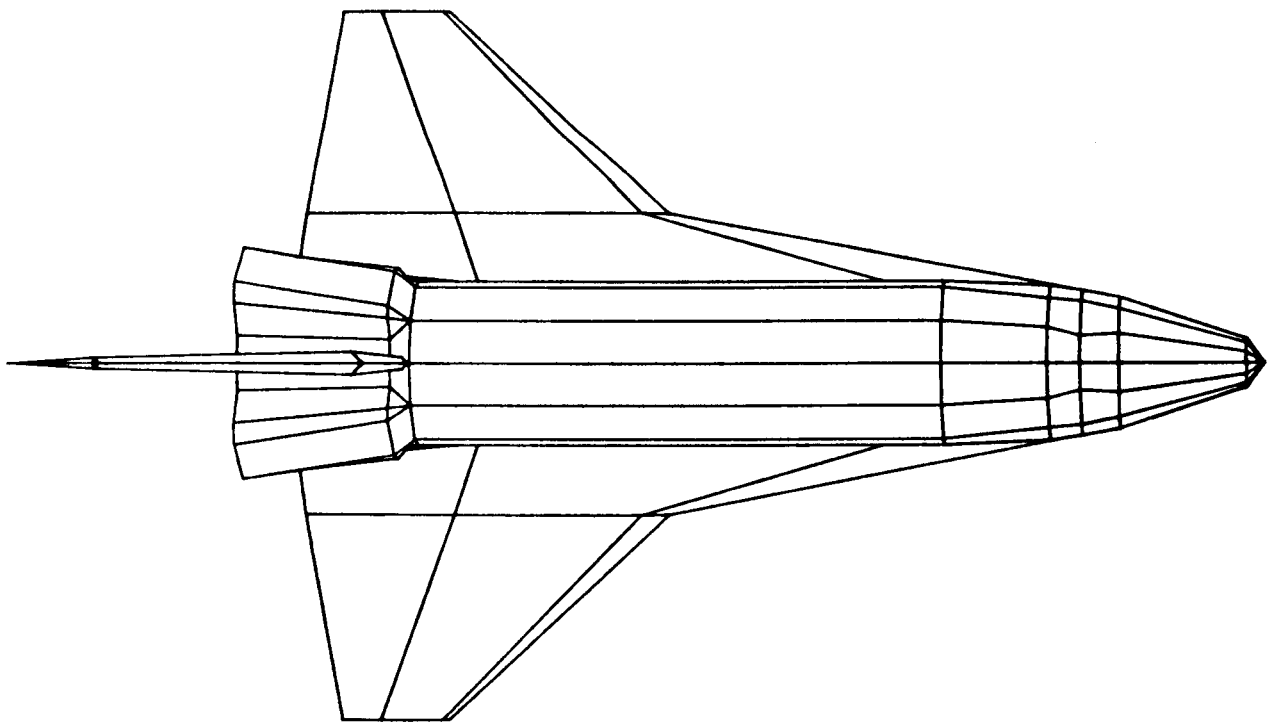

Sample Session #1 - continued

DO YOU WANT THE IMAGE SAVED IN A METAFILE ?
IF YOU PRESS ONLY THE "RETURN" KEY,
THE IMAGE WILL NOT BE SAVED.

? NO

ENTER THE YAW, ROLL, AND/OR PITCH ANGLES.
(IF YOU PRESS ONLY THE "RETURN" KEY, THE ANGLES
"YR90 RR90" WILL BE USED.)

? QUIT

Sample Session #1 - concluded

REVERT. NORMAL CODAC RUN

/

Sample Session #2

**/GET,CODAC,AGDEMO/UN=NTFLIB
/CODAC**

Terminal Menu:

512.	AED 512
1104.	Sieko 1104
4014.	Tektronix 4014
4105.	Tektronix 4105
4107.	Tektronix 4107
4109.	Tektronix 4109
4115.	Tektronix 4115

Which Terminal are You Using ? **4109**

Capacity Menu:

100.	100 or fewer panels
1000.	1000 or fewer panels
1400.	1400 or fewer panels

How Many Panels Does Your Geometry Have ? **1000**

Sample Session #2 - continued

CODAC

COCKPIT ORIENTED DISPLAY OF AIRCRAFT CONFIGURATIONS

VERSION 1.4 JANUARY 1988

ENTER THE NAME OF THE FILE CONTAINING YOUR GEOMETRY:

? **AGDEMO**

THIS GEOMETRY FILE IS IN CRAIDON FORMAT
AND HAS BEEN READ AND VERIFIED.

WHEN IT WAS CREATED, THIS MODEL HAD A SPECIFIC
X/Y/Z/ AXIS ORIENTATION. AS IF YOU WERE SITTING IN
THE COCKPIT, ENTER THE DIRECTION AND AXIS NAME FOR
THREE DIRECTIONS: FORWARD, TO THE RIGHT, AND UP.
FOR EXAMPLE, "-X,+Y,+Z" INDICATES THAT X DECREASES
MOVING FORWARD, Y INCREASES MOVING TO THE RIGHT,
AND Z INCREASES MOVING UP.

THE MODEL ORIENTATION "-X+Y+Z" WILL BE ASSUMED
IF YOU SIMPLY PRESS THE "RETURN" KEY.

? **+X+Y+Z**

REQUESTED ORIENTATION: "+X+Y+Z".

ENTER THE YAW, ROLL, AND/OR PITCH ANGLES.
(IF YOU PRESS ONLY THE "RETURN" KEY, THE ANGLES
"YR120 RR20" WILL BE USED.)

? **YR130 RR40**

ENTER THE SCALE FACTOR AND VIEWING DISTANCE,
OR ENTER "AUTO" FOR AUTOMATIC SCALING WITH
A SLIGHT PERSPECTIVE.
(IF YOU PRESS ONLY THE "RETURN" KEY THE RESPONSE
"AUTO" WILL BE ASSUMED.)

? *(carriage return)*

Sample Session #2 - continued

A REMINDER: WHEN YOU FINISH VIEWING THE PLOT ---
--- PRESS THE SPACE BAR, NOT THE "RETURN" KEY.

DO YOU WANT THE IMAGE FRAMED?
(IF YOU PRESS ONLY THE "RETURN" KEY,
A FRAME WILL NOT BE DRAWN.)

? NO

DO YOU WANT THE ANGLES DISPLAYED WITH THE IMAGE?
IF YOU PRESS ONLY THE "RETURN" KEY,
THE ANGLES WILL NOT BE DISPLAYED.

? N

Sample Session #2 - continued

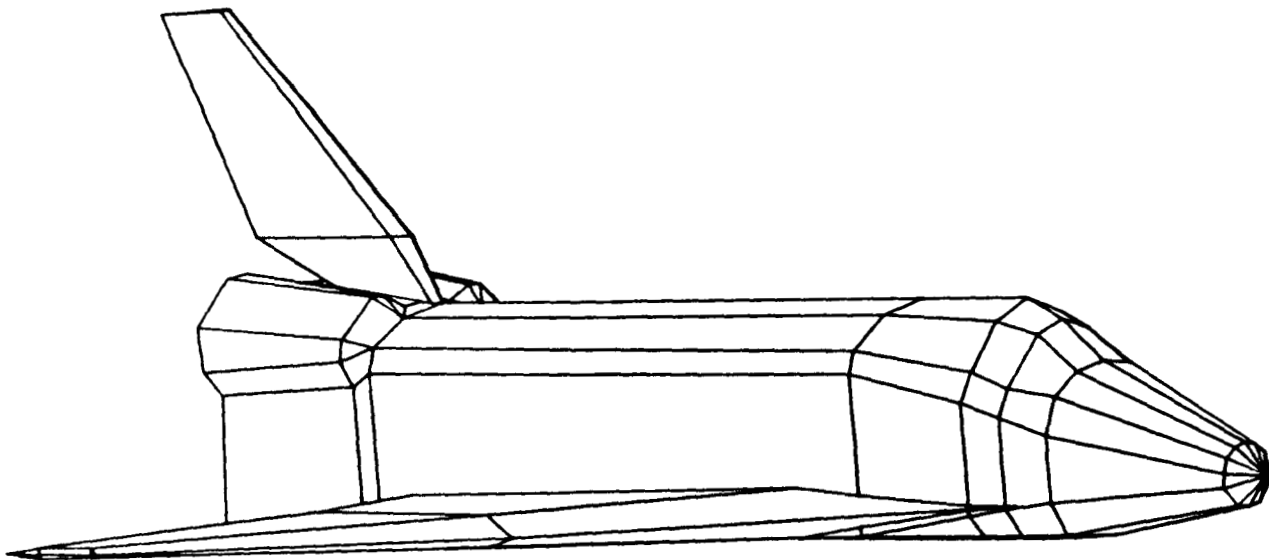

Sample Session #2 - continued

DO YOU WANT THE IMAGE SAVED IN A METAFILE ?
IF YOU PRESS ONLY THE "RETURN" KEY,
THE IMAGE WILL NOT BE SAVED.

? **YES**

ENTER THE NAME OF THE METAFILE TO BE CREATED.
(IF YOU PRESS ONLY THE "RETURN" KEY,
THE METAFILE NAME "MF1" WILL BE USED.)

? **META1**

THE NEW METAFILE NAME IS "META1"

ENTER THE YAW, ROLL, AND/OR PITCH ANGLES.
(IF YOU PRESS ONLY THE "RETURN" KEY, THE ANGLES
"YR130 RR30" WILL BE USED.)

? **PU90**

ENTER THE SCALE FACTOR AND VIEWING DISTANCE,
OR ENTER "AUTO" FOR AUTOMATIC SCALING WITH
A SLIGHT PERSPECTIVE.
(IF YOU PRESS ONLY THE "RETURN" KEY THE RESPONSE
"AUTO" WILL BE ASSUMED.

? *(carriage return)*

A REMINDER: WHEN YOU FINISH VIEWING THE PLOT ---
--- PRESS THE SPACE BAR, NOT THE "RETURN" KEY.

DO YOU WANT THE IMAGE FRAMED?
(IF YOU PRESS ONLY THE "RETURN" KEY,
A FRAME WILL NOT BE DRAWN.)

? *(carriage return)*

DO YOU WANT THE ANGLES DISPLAYED WITH THE IMAGE?
IF YOU PRESS ONLY THE "RETURN" KEY,
THE ANGLES WILL NOT BE DISPLAYED.

? *(carriage return)*

Sample Session #2 - continued

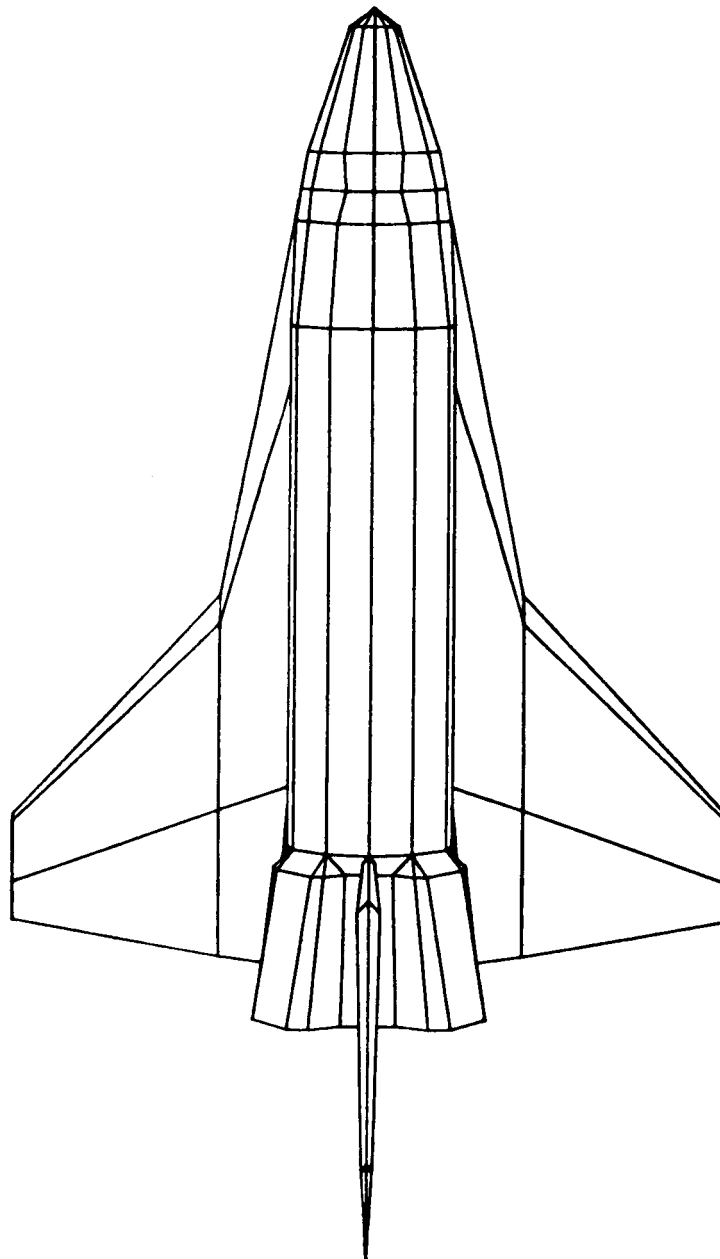

Sample Session #2 - continued

DO YOU WANT THE IMAGE SAVED IN A METAFILE ?
IF YOU PRESS ONLY THE "RETURN" KEY,
THE IMAGE WILL NOT BE SAVED.

? Y

ENTER THE NAME OF THE METAFILE TO BE USED.
THE FOLLOWING METAFILES HAVE BEEN USED:

META1

(IF YOU PRESS ONLY THE "RETURN" KEY,
THE METAFILE "META1" WILL CONTINUE TO BE USED.)

? (carriage return)

ENTER THE YAW, ROLL, AND/OR PITCH ANGLES.
(IF YOU PRESS ONLY THE "RETURN" KEY, THE ANGLES
"PU90" WILL BE USED.)

? YR172 PD15

ENTER THE SCALE FACTOR AND VIEWING DISTANCE,
OR ENTER "AUTO" FOR AUTOMATIC SCALING WITH
A SLIGHT PERSPECTIVE.
(IF YOU PRESS ONLY THE "RETURN" KEY THE RESPONSE
"AUTO" WILL BE ASSUMED.)

? (carriage return)

A REMINDER: WHEN YOU FINISH VIEWING THE PLOT ---
--- PRESS THE SPACE BAR, NOT THE "RETURN" KEY.

DO YOU WANT THE IMAGE FRAMED?
(IF YOU PRESS ONLY THE "RETURN" KEY,
A FRAME WILL NOT BE DRAWN.)

? (carriage return)

DO YOU WANT THE ANGLES DISPLAYED WITH THE IMAGE?
IF YOU PRESS ONLY THE "RETURN" KEY,
THE ANGLES WILL NOT BE DISPLAYED.

? (carriage return)

Sample Session #2 - continued

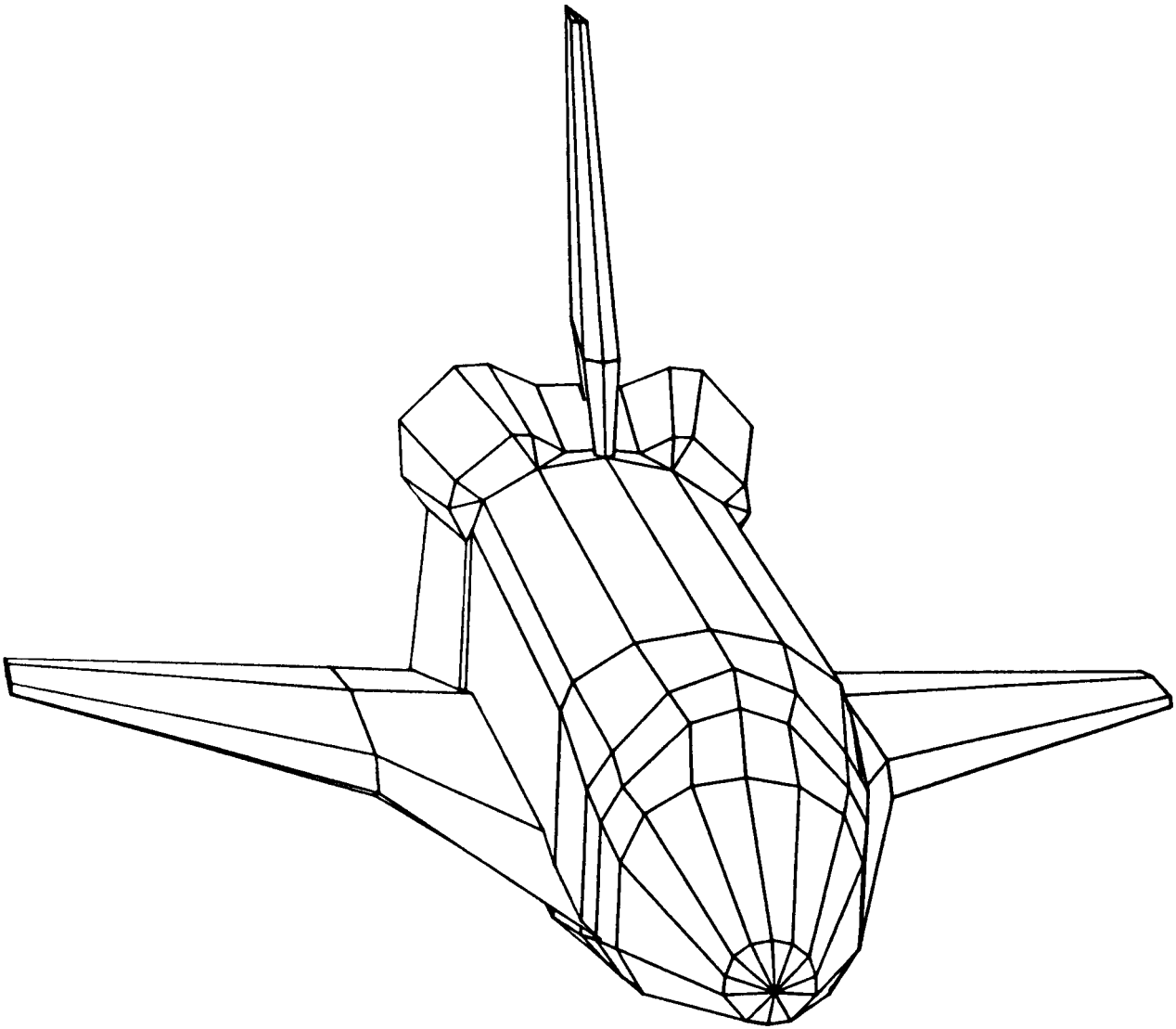

Sample Session #2 - continued

DO YOU WANT THE IMAGE SAVED IN A METAFILE ?
IF YOU PRESS ONLY THE "RETURN" KEY,
THE IMAGE WILL NOT BE SAVED.

? Y

ENTER THE NAME OF THE METAFILE TO BE USED.
THE FOLLOWING METAFILES HAVE BEEN USED:

META1

(IF YOU PRESS ONLY THE "RETURN" KEY,
THE METAFILE "META1" WILL CONTINUE TO BE USED.)

? (carriage return)

ENTER THE YAW, ROLL, AND/OR PITCH ANGLES.
(IF YOU PRESS ONLY THE "RETURN" KEY, THE ANGLES
"YR172 PD15" WILL BE USED.)

? YL160 PU20

ENTER THE SCALE FACTOR AND VIEWING DISTANCE,
OR ENTER "AUTO" FOR AUTOMATIC SCALING WITH
A SLIGHT PERSPECTIVE.
(IF YOU PRESS ONLY THE "RETURN" KEY THE RESPONSE
"AUTO" WILL BE ASSUMED.)

? (carriage return)

A REMINDER: WHEN YOU FINISH VIEWING THE PLOT ---
--- PRESS THE SPACE BAR, NOT THE "RETURN" KEY.

DO YOU WANT THE IMAGE FRAMED?
(IF YOU PRESS ONLY THE "RETURN" KEY,
A FRAME WILL NOT BE DRAWN.)

? (carriage return)

DO YOU WANT THE ANGLES DISPLAYED WITH THE IMAGE?
IF YOU PRESS ONLY THE "RETURN" KEY,
THE ANGLES WILL NOT BE DISPLAYED.

? (carriage return)

Sample Session #2 - continued

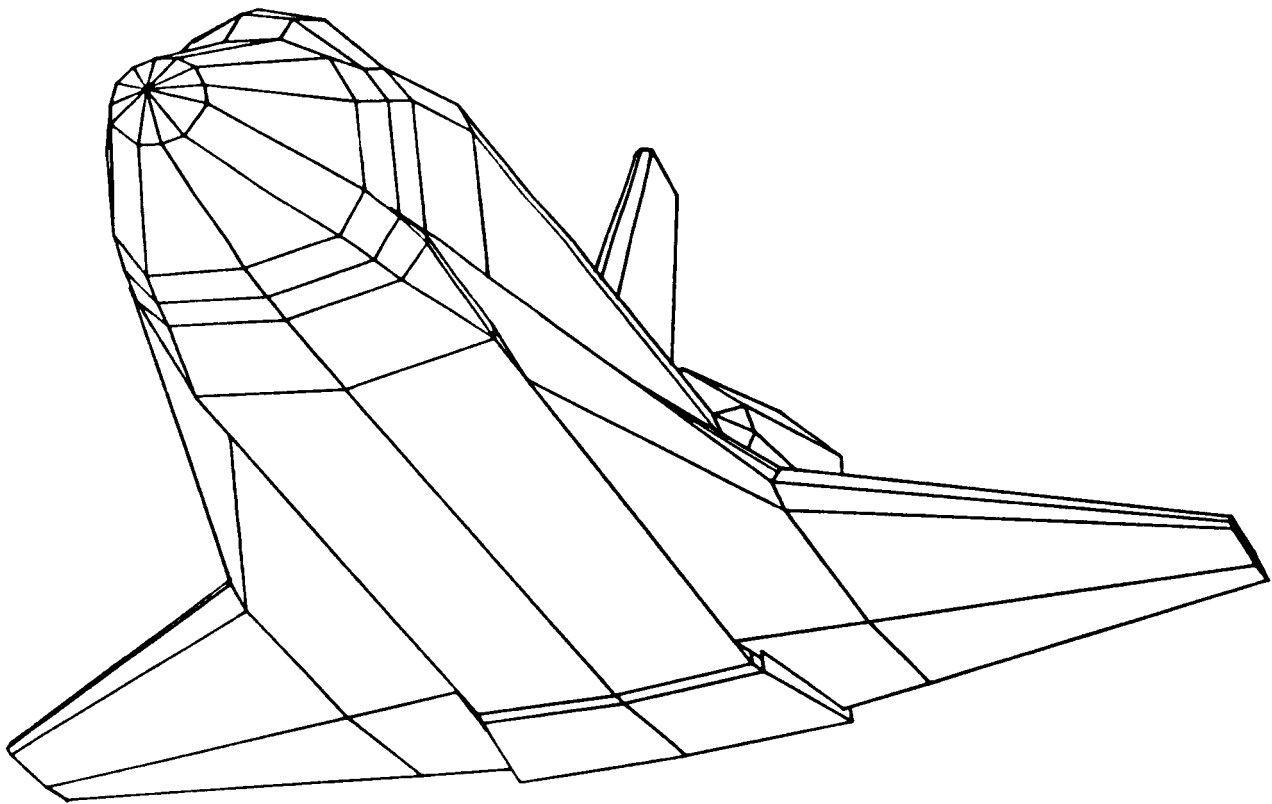

Sample Session #2 - continued

DO YOU WANT THE IMAGE SAVED IN A METAFILE ?
IF YOU PRESS ONLY THE "RETURN" KEY,
THE IMAGE WILL NOT BE SAVED.

? Y

ENTER THE NAME OF THE METAFILE TO BE USED.
THE FOLLOWING METAFILES HAVE BEEN USED:

META1

(IF YOU PRESS ONLY THE "RETURN" KEY,
THE METAFILE "META1" WILL CONTINUE TO BE USED.)

? *(carriage return)*

ENTER THE YAW, ROLL, AND/OR PITCH ANGLES.
(IF YOU PRESS ONLY THE "RETURN" KEY, THE ANGLES
"YL160 PU20" WILL BE USED.)

? QUIT

Sample Session #2 - continued

```
REVERT. NORMAL CODAC RUN  
/SAVE,META1  
/GET,MFEDIT/UN=NTFLIB  
/MFEDIT,4014
```

Sample Session #2 - continued

THE DI-3000 METAFILE TRANSLATOR
VERSION 4.10

M> ? SET METAFILE 1 META1
M> ? DIRECTORY 1

DIRECTORY OF METAFILE NUMBER 1

PICTURE NUMBER	PICTURE SIZE	PICTURE TITLE
1	10	
2	9	
3	12	
4	10	

M> ? DRAW PICTURE 1

Sample Session #2 - continued

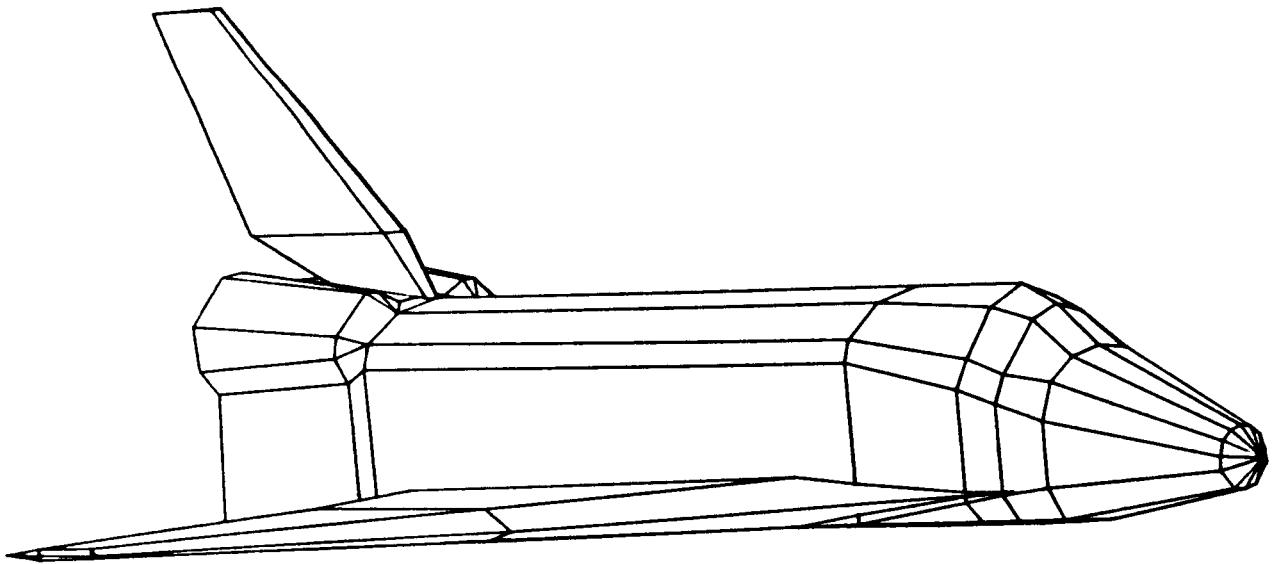

Sample Session #2 - continued

M> ? D P 4

Sample Session #2 - continued

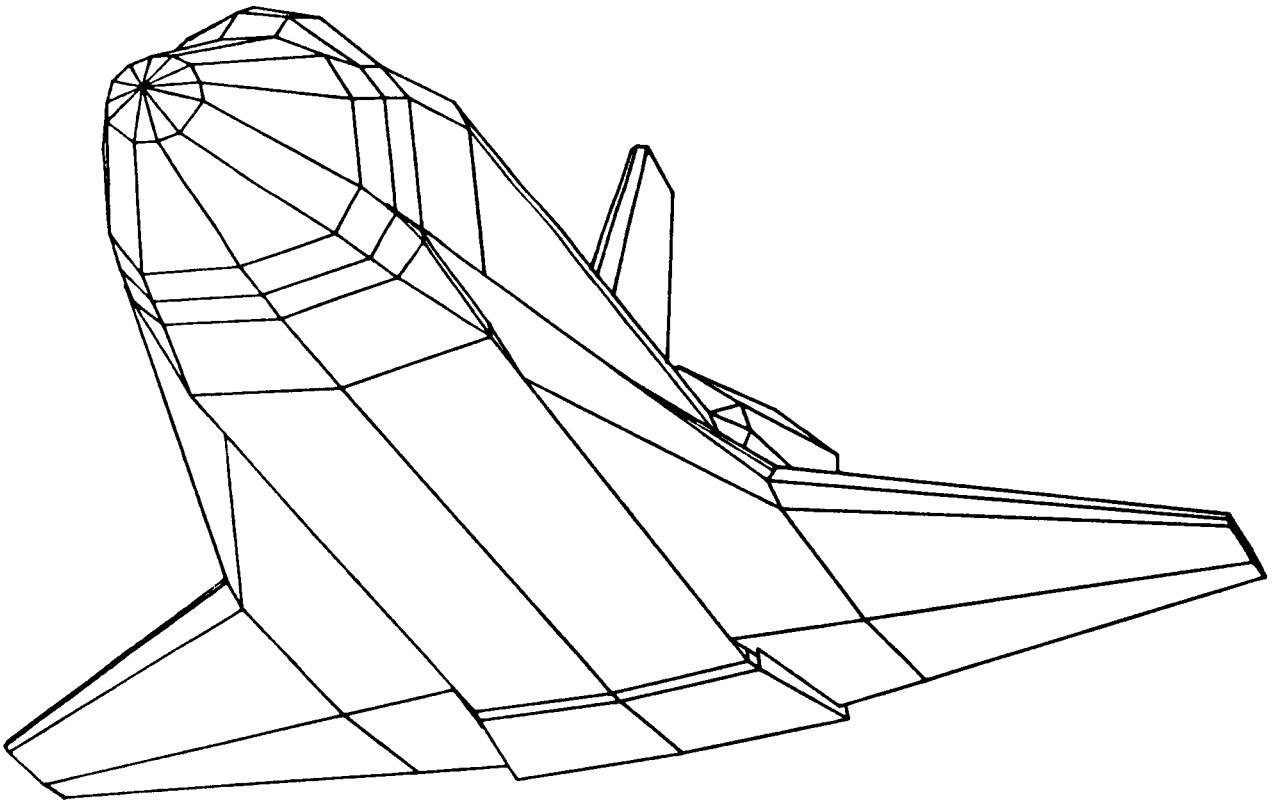

Sample Session #2 - continued

```
M> ? DEF BOX ON  
M> ? SET VIEWPORT 1 (-.75 .75 -.75 .75)  
M> ? SET WINDOW 1 (-1.1 1.1 -1.1 1.1)  
M> ? D P 4 V 1
```

Sample Session #2 - continued

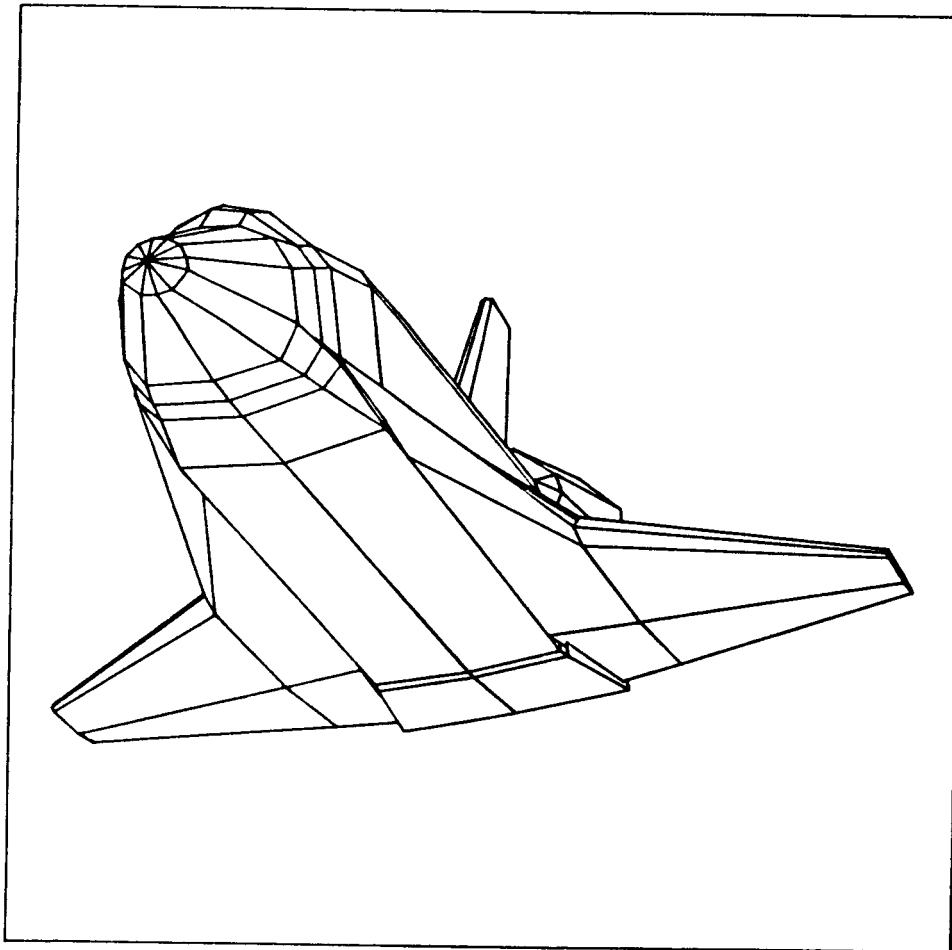

Sample Session #2 - continued

M> ? SV 1 (-1 0 0 1)

M> ? SV 2 (0 1 0 1)

M> ? SV 3 (-1 0 -1 0)

M> ? SV 4 (0 1 -1 0)

M> ? SET DEV 0 ON

M> ? DP 1 V 1 P 2 V 2 P 3 V 3 P 4 V 4

(opens metafile DIMETA)

Sample Session #2 - continued

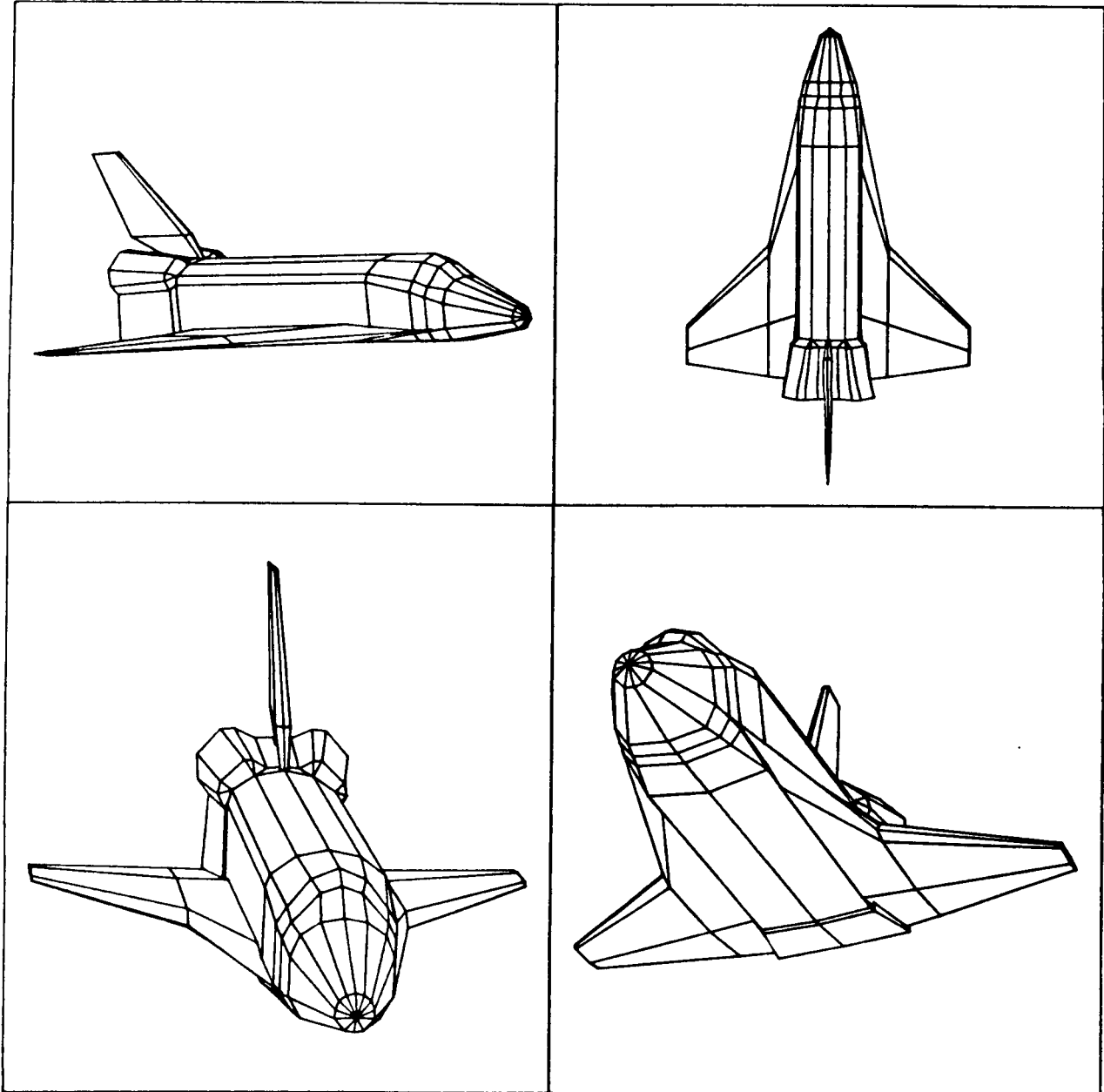

Sample Session #2 - continued

```
M> ? SET DEV 0 OFF  
M> ? EXIT
```

Sample Session #2 - continued

HAVE A NICE DAY
REVERT. DI-3000 TRANSLATOR RUN COMPLETE
/MFEDIT,4014

Sample Session #2 - continued

THE DI-3000 METAFILE TRANSLATOR
VERSION 4.10

M> ? S MF 1 DIMETA
M> ? DIR 1

DIRECTORY OF METAFILE NUMBER 1

PICTURE NUMBER	PICTURE SIZE	PICTURE TITLE
1	40	

M> ? DP 1

Sample Session #2 - continued

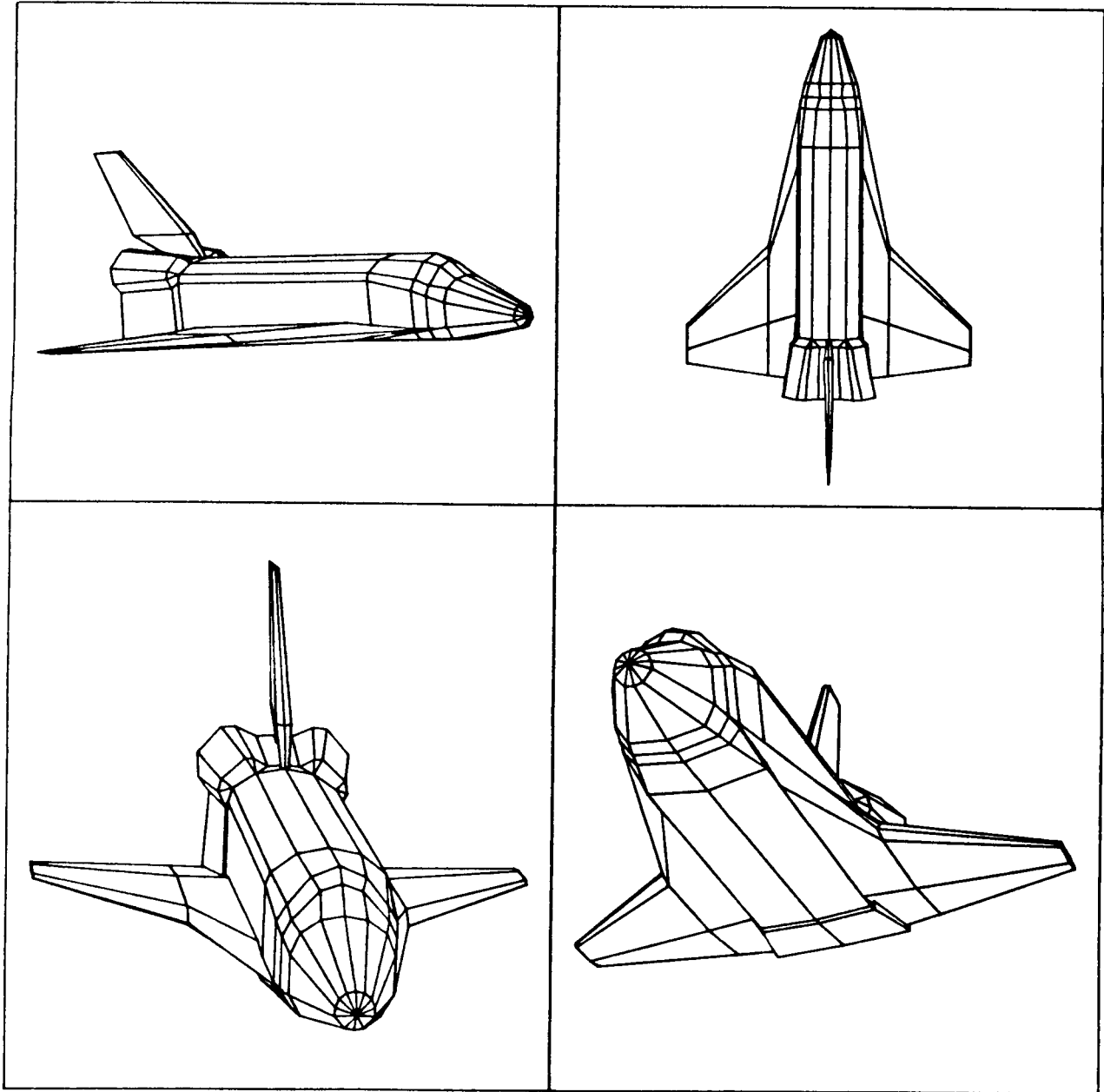

Sample Session #2 - continued

M> ? EXIT

Sample Session #2 - concluded

```
HAVE A NICE DAY  
REVERT. DI-3000 TRANSLATOR RUN COMPLETE  
/SAVE,DIMETA=WOWPLOT  
/
```

Appendix B

Sample Batch Jobs

Sample Batch Job #1

```
RUN1,T500.  
USER,xxxxxxx,pppp.  
CHARGE,yyyyyy,LRC.  
DELIVER.zzzzzzzz  
FILESET,IA=CPF.  
PURGE,DAY1,OUT1/NA.  
GET,CODAC,AGDEMO/UN=NTFLIB.  
CODAC,1000.  
REPLACE,META1.  
DAYFILE,DAY1.  
REPLACE,DAY1.  
REPLACE,OUTPUT=OUT1.  
CLEAR.  
EXIT.  
DAYFILE,DAY1.  
REPLACE,DAY1.  
REPLACE,OUTPUT=OUT1.  
CLEAR.  
--EOR--  
AGDEMO  
+X+Y+Z  
YR130 RR40  
AUTO  
NO  
NO  
YES  
META1  
PU90  
AUTO  
NO  
NO  
YES  
META1  
YR172 PD15  
AUTO  
NO  
NO  
YES  
META1  
YL160 PU20  
AUTO  
NO  
NO  
YES
```

(geometry file name)
(object orientation)
(rotation angles)
(automatic scaling and perspective)
(frame the image?)
(display rotations on the image?)
(save the image on a metafile?)
(metafile name)

Sample Batch Job #1 - continued

META1
QUIT
--EOR--
--EOI--

Sample Batch Job #1 - continued

DAYFILE:

```
07.35.49.RUN1,T500.
07.35.49.USER,xxxxxxx,.
07.35.49.ABSC, B.
07.35.49.CHARGE,yyyyyy,LRC.
07.35.49.$PROLOG,,ECHOY,PROCFIL.
07.35.49.$SETFS,ECHOY/FS=AD.
07.35.49.ECHOY.
07.35.50.RETURN(ECHOY)
07.35.53.DELIVER.zzzzzzzz
07.35.53.FILESET,IA=CPF.
07.35.54.$GET,ZZZFSET/UN=SYSTEMX,PW=.
07.35.55.ZZZFSET/IA=CPF,DA=.
07.35.55. 4110B LOAD FL, 14530B RUN FL.
07.35.55. 0.009 CP SECS, 4657B CM USED.
07.35.55.$RETURN,ZZZFSET.
07.35.55.PURGE,DAY1,OUT1/NA.
07.35.57.GET,CODAC,AGDEMO/UN=NTFLIB.
07.35.59.CODAC,1000.
07.36.00.SET,R1=SC.EQ.TSSC.OR.SC.EQ.DISC.
07.36.00.IF,R1,LAB1.
07.36.00.ELSE,LAB1.
07.36.00.ATTACH,DD=DDDUMMY/UN=LIBRARY,ST=CPF.
07.36.03.BEGIN,CAPAC,BCODAC,1000.
07.36.05.GET,LGO=CODTR2/UN=NTFLIB.
07.36.08.REVERT.
07.36.08.ENDIF,LAB1.
07.36.08.GET,CODSEG/UN=NTFLIB.
07.36.11.ATTACH,DI3000/UN=LIBRARY,ST=CPF.
07.36.13.ATTACH,MFNODE/UN=LIBRARY,ST=CPF.
07.36.15.ATTACH,SSDUMMY/UN=LIBRARY,ST=CPF.
07.36.18.ATTACH,DIERFN/UN=LIBRARY,ST=CPF.
07.36.20.RETURN,ABS.
07.36.20.REWIND,LGO,CODSEG.
07.36.20.LDSET,LIB=DI3000.
07.36.20.SEGLOAD,I=CODSEG.
07.36.20.LOAD,LGO,MFNODE,SSDUMMY,DD.
07.36.20.NOGO.
07.37.26. CM LWA+1 =273233B, LOADER USED 240000B
07.37.26.RETURN,LGO,CODSEG,DI3000,MFNODE,SSDUMMY,DD.
07.37.26.ABS.
07.38.30. STOP
07.38.30. 315300 MAXIMUM EXECUTION FL.
```

Sample Batch Job #1 - concluded

07.38.30. 37.820 CP SECONDS EXECUTION TIME.
07.38.30.REVERT.
07.38.30.REPLACE,META1.
07.38.34.DAYFILE,DAY1.

Sample Batch Job #2

```
RUN2,T500.  
USER,xxxxxxx,pppp.  
CHARGE,yyyyyy,LRC.  
DELIVER.zzzzzzzz  
FILESET,IA=CPF.  
PURGE,DAY2,OUT2/NA.  
GET,META1.  
GET,MFEDIT/UN=NTFLIB.  
MFEDIT,DUMMY.  
SAVE,DIMETA=META2.  
DAYFILE,DAY2.  
REPLACE,DAY2.  
REPLACE,OUTPUT=OUT2.  
CLEAR.  
EXIT.
```

```
DAYFILE,DAY2.  
REPLACE,DAY2.  
REPLACE,OUTPUT=OUT2.  
CLEAR.
```

--EOR--

```
SET MF 1 META1  
SET DEV 0 ON  
SET DEV 1 OFF  
SET V 1 (-1 0 0 1)  
SET V 2 (0 1 0 1)  
SET V 3 (-1 0 -1 0)  
SET V 4 (0 1 -1 0)  
SET W 1 (-1.1 1.1 -1.1 1.1)  
DEF BOX ON  
D P 1 V 1 P 2 V 2 P 3 V 3 P 4 V 4  
SET DEV 0 OFF
```

```
(open the input metafile)  
(create the output metafile)  
(turn off the standard output device)  
(define viewport #1)  
(define viewport #2)  
(define viewport #3)  
(define viewport #4)  
(define window #1)  
(turn on viewport borders)  
(draw 4 images in 4 defined viewports)  
(close the output metafile)
```

EXIT

--EOR--

--EOI--

Sample Batch Job #2 - concluded

DAYFILE:

07.44.11.RUN2,T500.
07.44.11.USER,xxxxxxx,.
07.44.11.ABSC, B.
07.44.11.CHARGE,yyyyyy,LRC.
07.44.11.\$PROLOG,,ECHOY,PROCFIL.
07.44.11.\$SETFS,ECHOY/FS=AD.
07.44.11.ECHOY.
07.44.13.RETURN(ECHOY)
07.44.17.DELIVER.zzzzzzzz
07.44.17.FILESET,IA=CPF.
07.44.18.\$GET,ZZZFSET/UN=SYSTEMX,PW=.
07.44.19.ZZZFSET/IA=CPF,DA=.
07.44.19. 4110B LOAD FL, 14530B RUN FL.
07.44.19. 0.008 CP SECS, 4657B CM USED.
07.44.19.\$RETURN,ZZZFSET.
07.44.20.PURGE,DAY2,OUT2/NA.
07.44.25.GET,META1.
07.44.27.GET,MFEDIT/UN=NTFLIB.
07.44.28.MFEDIT,DUMMY.
07.44.29.*
07.44.29.ATTACH,DIMFT,DI3000,DIERFN,MFNODE,SSDUMMY,DD=DDDUMMY/UN=LIBRARY.
07.44.30.LDSET,LIB=DI3000,MAP=N.
07.44.30.LOAD,MFNODE,SSDUMMY,DD.
07.44.30.DIMFT.
07.44.40. CM LWA+1 = 55610B, LOADER USED 77500B
07.44.57. END METRNS
07.44.57. 75600 MAXIMUM EXECUTION FL.
07.44.57. 7.556 CP SECONDS EXECUTION TIME.
07.44.57.REVERT. DI-3000 TRANSLATOR RUN COMPLETE
07.44.57.REPLACE,DIMETA=META2.
07.45.00.DAYFILE,DAY2.

Sample Batch Job #3

```
RUN3,T500.  
USER,xxxxxx,pppp.  
CHARGE,yyyyyy,LRC.  
DELIVER.zzzzzzzz  
FILESET,IA=CPF.  
PURGE,DAY3,OUT3/NA.  
GET,META2.  
PLOT.CAL,11  
CONT. // PLEASE USE .2 MM BLACK LEROY PEN //  
CONT. // AND PLAIN WHITE PAPER //  
DAYFILE,DAY3.  
REPLACE,DAY3.  
REPLACE,OUTPUT=OUT3.  
CLEAR.  
EXIT.  
DAYFILE,DAY3.  
REPLACE,DAY3.  
REPLACE,OUTPUT=OUT3.  
CLEAR.  
--EOR--  
SET MF 1 META2  
SET V 1 (-.95 .95 -.95 .95) (open the metafile)  
D P 1 V 1 (reduce the viewport to avoid the paper's edges)  
EXIT (draw the image)  
--EOR--  
--EOI--
```

Sample Batch Job #3 - concluded

DAYFILE:

15.21.04.RUN3,T500.
15.21.04.USER,xxxxxx,.
15.21.04.ABSC, B.
15.21.04.CHARGE,yyyyyy,LRC.
15.21.04.\$PROLOG,,ECHOY,PROCFIL.
15.21.05.\$SETFS,ECHOY/FS=AD.
15.21.05.ECHOY.
15.21.05.RETURN(ECHOY)
15.21.10.DELIVER.zzzzzzzz
15.21.10.FILESET,IA=CPF.
15.21.11.\$GET,ZZZFSET/UN=SYSTEMX,PW=.
15.21.12.ZZZFSET/IA=CPF,DA=.
15.21.12. 4110B LOAD FL, 14530B RUN FL.
15.21.12. 0.016 CP SECS, 4657B CM USED.
15.21.12.\$RETURN,ZZZFSET.
15.21.12.PURGE,DAY3,OUT3/NA.
15.21.14. DAY3 NOT FOUND.
15.21.15. OUT3 NOT FOUND.
15.21.15.GET,META2.
15.21.17.PLOT.CAL,11
15.21.19.CONT. // PLEASE USE .2 MM BLACK LEROY PEN //
15.21.19.CONT. // ON PLAIN WHITE PAPER //
15.21.20. THIS JOB HAS ***** PLOT ***** OUTPUT
15.21.34. ENTER CALTP VSN-CFO,JSN.PLTNNN.
15.22.51. CFO. PLT458.
15.22.51. VSN ACCEPTED.
15.22.52. NOISE SIZE IGNORED FOR PE/GE.
15.23.37.NT035, ASSIGNED TO CALTPE, VSN=PLT458.
15.23.49. ***** PLOT OUTPUT COMPLETED *****
15.23.49.DAYFILE,DAY3.

References

1. Hedgley, David R., Jr.: A General Solution to the Hidden-Line Problem. NASA Reference Publication 1085, 1982.
2. DI-3000 User's Guide. Precision Visuals, Inc., Boulder, Colorado, 1984.
3. Metafile System User's Guide. Precision Visuals, Inc., Boulder, Colorado, 1984.
4. Software Release Bulletin, Precision Visuals, Inc. Products, for NOS/VE 1.2.1 Level 664 (preliminary). CDC document SMD-131243, Control Data Corporation, St. Paul, Minnesota, 1987.
5. Taylor, Nancy L.; Randall, Donald P.; Matthews, Christine G.; Gates, Raymond L.; Bowen, John T.; Jones, Kennie H.; von Ofenheim, William H.; Gooden, Arthur L.; Johnson, Mary M.; Everton, Eric L.; and Roland, Vincent R.: Graphics Mini Manual. NASA Technical Memorandum 87622, 1985.



Report Documentation Page

1. Report No. NASA CR-181650		2. Government Accession No.		3. Recipient's Catalog No.	
4. Title and Subtitle CODAC (Cockpit Oriented Display of Aircraft Configurations) Version 1.4 User's Guide				5. Report Date January 1988	
				6. Performing Organization Code	
7. Author(s) Bradford D. Bingel, Erma L. Wilson, and Michelle S. Hollis				8. Performing Organization Report No.	
				10. Work Unit No. 505-68-71-03	
9. Performing Organization Name and Address Computer Sciences Corporation Applied Technology Division 3217 North Armistead Avenue Hampton, VA 23666-1379				11. Contract or Grant No. NAS1-17999	
				13. Type of Report and Period Covered Contractor Report	
12. Sponsoring Agency Name and Address National Aeronautics and Space Administration Langley Research Center Hampton, VA 23665-5225				14. Sponsoring Agency Code	
				15. Supplementary Notes Langley Research Center Technical Monitor: Julio Chu	
16. Abstract <p>The Cockpit Oriented Display of Aircraft Configurations (CODAC) package is an interactive FORTRAN 77 graphics program which produces high-quality publication-grade hidden-line images of three-dimensional wireframe objects. The term "Cockpit Oriented" is used because CODAC rotates objects relative to the changing aircraft axis system (rather than about a fixed global axis system) and uses the more familiar directions of yaw, roll, and pitch. In addition, CODAC accepts geometry data in a variety of formats (LaWGS, Craidon, Hess, and FVS data check), and automatically selects the appropriate panel driver. Finally, CODAC makes full use of the Precision Visuals' DI-3000 metafile option, allowing users to save, edit, and print images for group presentations or research publications.</p>					
17. Key Words (Suggested by Author(s)) Computer Programs Computer Graphics Aircraft Configurations Hidden-line Displays Wireframe Models			18. Distribution Statement Unclassified - Unlimited Subject Category 02		
19. Security Classif. (of this report) Unclassified	20. Security Classif. (of this page) Unclassified	21. No. of Pages 64	22. Price A04		