

135
42, 3
A

APR 25 1946
NATIONAL ADVISORY COMMITTEE
FOR AERONAUTICS

TECHNICAL NOTE

No. 998

NUMERICAL PROCEDURES FOR THE CALCULATION OF THE
STRESSES IN MONOCOQUES

III - CALCULATION OF THE BENDING MOMENTS IN FUSELAGE FRAMES

By N. J. Hoff, Paul A. Libby, and Bertram Klein
Polytechnic Institute of Brooklyn



Washington N A C A LIBRARY
April 1946 LANGLEY MEMORIAL AERONAUTICAL
LABORATORY
Langley Field, Va.

NATIONAL ADVISORY COMMITTEE FOR AERONAUTICS

TECHNICAL NOTE NO. 998

NUMERICAL PROCEDURES FOR THE CALCULATION OF THE
STRESSES IN MONOCOQUES

III - CALCULATION OF THE BENDING MOMENTS IN FUSELAGE FRAMES

By N. J. Hoff, Paul A. Libby, and Bertram Klein

SUMMARY

This report deals with the calculation of the bending moments in and the distortions of fuselage rings upon which known concentrated and distributed loads are acting. In the procedure suggested, the ring is divided into a number of beams each having a constant radius of curvature. The forces and moments caused in the end sections of the beams by individual unit displacements of the end sections are listed in a table designated as the operations table in conformity with Southwell's nomenclature.

The operations table and the external loads are equivalent to a set of linear equations. For their solution the following three procedures are presented:

1. Southwell's method of systematic relaxations. This is a step-by-step approximation procedure guided by the physical interpretation of the changes in the values of the unknowns.
2. The growing unit procedure in which the individual beams are combined successively into beams of increasing length until finally the entire ring becomes a single beam. In each step of the procedure a set of not more than three simultaneous linear equations is solved.
3. Solution of the entire set of simultaneous equations by the methods of the matrix calculus.

In order to demonstrate the manner in which the calculations may be carried out, the following numerical examples are worked out:

1. Curved beam with both its end sections rigidly fixed. The load is a concentrated force.
2. Egg-shape ring with symmetric concentrated loads
3. Circular ring with antisymmetric concentrated loads and shear flow (torsion of the fuselage)
4. Same with V-braces incorporated in the ring
5. Egg-shape ring with antisymmetric concentrated loads and shear flow (torsion of the fuselage)
6. Same with V-braces incorporated in the ring

The results of these calculations are checked, whenever possible, by calculations carried out according to known methods of analysis. The agreement is found to be good.

The amount of work necessary for the solution of ring problems by the methods described in the present report is practically independent of the degree of redundancy of the structure. For this reason the methods are recommended for use particularly in problems of rings having one or more internal bracing elements.

INTRODUCTION

The methods and the formulas used in the analysis of monocoque aircraft structures have been developed almost invariably for cylinders of circular, or possibly elliptic, cross section and of uniform mechanical properties. Yet, in actual aircraft such structural elements are seldom, if ever, found. Unfortunately, the direct methods of analysis are little suited to cope with problems involving complex cross-sectional shapes, irregular distribution of reinforcing elements, concentrated loads, and cut-outs. It is believed that the indirect methods recently advanced by Hardy Cross, and particularly by R. V. Southwell, (references 1 and 2) promise a solution of such problems.

The fundamental justification for this indirect approach lies in the comparative ease with which stresses in a complex structure can be calculated if they are caused by some stipulated simple displacement, while the determination of the stresses and displacements caused by known external loads is often very difficult, or even impossible. The calculation of the stresses in a small unit of the structure corresponding to given displacements is known as the "unit problem" in Southwell's relaxation method. In this method the individual displacements involved in the unit problems are combined by a trial-and-error procedure until a displacement pattern of the entire structure is found that corresponds to an equilibrium of the internal stresses and the external loads over the entire structure.

In parts I and II (references 3 and 4) of the present investigation a convenient unit problem was devised and solved for the purpose of calculating the stresses in sheet-and-stringer combinations. Furthermore, a systematic procedure of combining the individual operations was developed which results in a rapid approach to the actual state of distortions caused by the known loads acting upon the structure. The stresses calculated by this procedure were found to be in reasonable agreement with those measured in experiments.

In the present report the indirect method is applied to the calculation of the bending moments in rings (frames) upon which known external loads are acting. It is planned to discuss in the future the stress problem of monocoque fuselages, which are combinations of rings and stiffened curved panels.

In the course of the present investigations it was found that the calculations necessary for the solution of the unit problems are rather laborious. For this reason the solution was worked out numerically and the results are presented in graphs and tables in part IV (reference 5). Moreover, it turned out that in many ring problems it is difficult to predict the most likely displacement patterns, and the order of magnitude of the displacements. This fact was not anticipated at the beginning of the present investigations since in the earlier work it was found that the displacements of reinforced panels could be predicted with a reasonable degree of accuracy. It appears that with rings the difficulty lies in visualizing the amounts of rotation of the end sections of the individual arcs, and to some extent the tangential displacements, while it is possible to anticipate comparatively well the radial displacement pattern. On the other hand, the

interaction between rotations, tangential displacements, and radial displacements is very strong, and the final bending moments, shear forces, and normal forces in the sections are often the small differences of large values caused by the individual distortions. Unfortunately, the Southwell procedure becomes very slowly convergent; that is, it yields the correct final results only after a very great number of individual operations, if the steps in the relaxation - or the individual displacements - are undertaken at random, without a preconceived picture of the final pattern of deformations.

In order to overcome this difficulty, a procedure has been worked out which might be termed the "procedure of the growing unit." In it the structure is broken up into units, the unit problems are solved, and the operations table is set up in the same manner as was suggested by Southwell. On the other hand, the solution of the stress problem by the trial-and-error procedure of the method of systematic relaxations is replaced by a procedure involving the combination of the individual units into units of increasing size. The external loads are balanced then by solving sets of two or three simultaneous linear equations involving the influence coefficients of the large units. The new procedure is reasonably simple and fast, as may be seen from the numerical examples contained in the body of the paper.

Finally, the examples presented in this report were also calculated by considering the so-called operations table of the Southwell method as a set of simultaneous linear equations, and solving it by the use of the matrix calculus. In the appendix a simple explanation is given of the matrix calculations necessary for the solution.

For the understanding of the present report familiarity with the Southwell and the Hardy Cross methods, or with parts I and II of this investigation is not required.

This investigation, conducted at the Polytechnic Institute of Brooklyn, was sponsored by and conducted with the financial assistance of the National Advisory Committee for Aeronautics.

SYMBOLS

A cross-sectional area of bar; of a point on a ring; or the included area of a ring; or a matrix

- A* effective shear area (based on tension)
- a lever arm of shear flow
- a, b, c, d, e, f, g matrix coefficients
- B, C, D, E points on a ring
- E Young's modulus of elasticity
- G shear modulus
- I moment of inertia of cross section; or identity matrix
- j matrix coefficient
- L developed length of ring segment
- M bending moment; or a matrix
- N end moment reacting on bar or on constraint
- q shear flow acting along bar
- R end radial reaction acting on bar or on constraint
- r radius of curvature of a ring segment
- T end tangential reaction acting on bar or on constraint;
or applied torque
- U strain energy
- u displacement of a point in tangential direction
- v displacement of a point in radial direction
- V shear force acting on a cross section
- w rotation of a section of a bar; or an unknown quantity
- x, y rectangular coordinate; or an unknown quantity
- z an unknown quantity
- β angle subtended by ring segment

γ section-length parameter (AL^2/I)

Δ determinant

$\kappa = 1 + (\beta^2/\gamma) [(1/\xi) + 1]$

$\lambda = 1 - (\beta^2/\gamma) [(1/\xi) + 1]$

$\nu = (G/E)$

$\xi = (A^*/A)$; or angular coordinate

ϕ angular coordinate

ω rotational coordinate

The symbols used to denote influence coefficients are defined in the following manner:

The term (ab) stands for the force or moment a caused by a unit movement in the direction of b (which direction is that of the force R or T , or of the moment M). Thus (nn) is the moment due to a unit rotation, while (tr) is the tangential force arising from a unit radial displacement. Further, to distinguish the reactions at the fixed end from those at the movable end, the subscripts F and M are employed. Consequently $(nt)_F$ is the moment arising at the fixed end of the curved bar as a result of a unit tangential displacement of the movable end, while $(tt)_M$ stands for the tangential force at the movable end due to a unit tangential displacement of that end.

The moment, radial force, and tangential force caused by a constant shear flow are denoted by the symbols n_q , r_q , and t_q , respectively. The values are valid for the end of the bar toward which the shear flows. At the opposite end the reactions considered here, are acting from the support upon the curved bar.

DEVELOPMENT OF THE RELAXATION METHOD WITH THE AID OF AN EXAMPLE

The Structure

The structure used as an example in the development of the procedure is shown in figure 1. It is a curved beam of

square cross section which may be thought of as an assembly of two cantilever quarter circular beams AB and AC joined rigidly at point A. As each of the two curved beams could support by itself the 100 pound load applied at A, the distribution of the load to the two beams cannot be determined by the laws of statics alone. The problem is three times redundant, since the unknown stresses in the cross section at A add up, in general, to an unknown normal force, an unknown shear force, and an unknown moment in the plane of the circles. There cannot be any force and moment resultants perpendicular to the plane, since the external load acts in the plane of the curved beam.

The problem of the load distribution can be solved only by taking into account the deformations of the structure. This can be done conveniently if the structure is considered cut at A and the deformations of each quarter-circle are calculated independently. When these calculations are completed, the continuity of the actual structure can be re-established without difficulty through a proper choice of the unknown moment and forces in section A, as will be shown later.

Unit Problem

The structure is broken up into two units; namely, the quarter circles AB and AC. The unit problem consists in finding the tangential (normal) force T, the radial (shear) force R, and the moment N (see fig. 2) under the action of which the free end point A (of the unit) undergoes any prescribed displacement u in the x direction, v in the y direction, and any prescribed rotation w, which latter is considered positive if it is counterclockwise like ω . The unit problem can be solved best by calculating first u, v, and w caused by unknown forces T and R, and an unknown moment N, and determining the unknowns afterwards so as to obtain the prescribed values of the displacements and the rotation. In conformity with standard practice extensional and shearing deformations will be neglected, since they are much smaller than the bending deformations.

The bending moment M caused by T, R, and N in a section of the curved beam defined by the angle ϕ (see fig. 2) is given by

$$M = Tr(1 - \cos(\phi)) + Rr \sin \phi + N \quad (1)$$

The relative rotation dw of two normal sections of the curved beam an infinitesimal distance ds apart

$$dw = Mds/(EI) = Mrd\phi/(EI) \quad (2)$$

Since point B is fixed, the rotation w_A of point A can be calculated from the integral

$$w_A = \int_0^{\pi/2} [Mr/(EI)] d\phi$$

Substitution of M from equation (1) and integration yields

$$w_A = (r/EI) \left\{ [(\pi/2) - 1] Tr + Rr + (\pi/2)N \right\} \quad (3)$$

When the infinitesimal element of the beam at ϕ undergoes a rotation dw , point A is displaced an infinitesimal distance du in the x direction, where

$$du = r(1 - \cos \phi)dw \quad (4)$$

With B fixed, the total displacement u_A of point A in the x direction becomes

$$u_A = \int_0^{\pi/2} du = (r^2/EI) \int_0^{\pi/2} M(1 - \cos \phi) d\phi$$

Substitution and integration gives

$$u_A = (r^3/EI) \left\{ [(3\pi/4) - 2] Tr + (1/2) Rr + [(\pi/2) - 1]N \right\} \quad (5)$$

When the infinitesimal element of the beam at ϕ undergoes an infinitesimal rotation dw , point A is displaced an infinitesimal distance dv in the y direction:

$$dv = r \sin \phi dw \quad (6)$$

Considerations similar to those stated before give

$$v_A = \int_0^{\pi/2} dv = (r^2/EI) \int_0^{\pi/2} M \sin \phi d\phi$$

and

$$v_A = (r^2/EI) \left\{ (1/2) Tr + (\pi/4) Rr + N \right\} \quad (7)$$

The task of determining the displacements of the end section A caused by the forces T and R and the moment N has thus been completed. The problem must now be inverted, and the values of T, R, and N must be calculated that cause prescribed distortions u_A , v_A , and w_A . This calculation can be carried out by solving the three simultaneous equations (3), (5), and (7) for the unknowns T, R, and N when the values of u_A , v_A , and w_A are given. In computations that follow later in this report it will be found convenient to have the solutions of three unit problems characterized by the following groups of prescribed distortions:

- (a) $u_A = 1$ $v_A = 0$ $w_A = 0$
 (b) $u_A = 0$ $v_A = 1$ $w_A = 0$
 (c) $u_A = 0$ $v_A = 0$ $w_A = 1$

The numerals 1 denote units in any convenient and consistent system of distances and angles.

The solution of equations (3), (5), and (7) corresponding to values (a) of the distortions is

$$T = 42.87 (EI/r^3) \quad R = -39.37 (EI/r^3) \quad N = 9.484 (EI/r^2)$$

When values (b) apply, the solution is

$$T = -39.37 (EI/r^3) \quad R = 42.87 (EI/r^3) \quad N = -13.03 (EI/r^2)$$

When values (c) apply, the solution is

$$T = 9.484 (EI/r^2) \quad R = -13.03 (EI/r^2) \quad N = 5.449 (EI/r)$$

In computing the above values a calculating machine had to be used, since small differences of large numbers had to be determined. The values can be verified by substitution in equations (3), (5), and (7), respectively.

In subsequent calculations, use will be made of quantities denoted as "influence coefficients." Influence coefficient tt is defined as the tangential force T caused by a

unit displacement in the tangential (t) direction; influence coefficient \widehat{tr} is the tangential force caused by a unit displacement in the radial (r) direction; \widehat{rn} denotes the radial force R caused by a unit rotation (in the n direction); and so forth. With this notation the solution of the unit problems may be stated concisely as

$$\begin{aligned} \widehat{tt} &= 42.87 (EI/r^3) & \widehat{tr} &= -39.37 (EI/r^3) & \widehat{tn} &= 9.484 (EI/r^2) \\ \widehat{rr} &= 42.87 (EI/r^3) & \widehat{rn} &= -13.03 (EI/r^2) & \widehat{nn} &= 5.449 (EI/r) \end{aligned} \quad (8)$$

Influence coefficients \widehat{rt} , \widehat{nt} , \widehat{nr} are not listed. The reason for the omission lies in the equalities

$$\widehat{rt} = \widehat{tr} \quad \widehat{nt} = \widehat{tn} \quad \widehat{nr} = \widehat{rn} \quad (9)$$

The validity of equations (9) follows directly from the expressions given earlier as the solutions of equations (3), (5), and (7).

The numerical values of the influence coefficients will now be computed for the example at hand. The moment of inertia of the cross section of the curved beam is

$$I = (1/2)^4 / 12 = 0.0052 \text{ inch}^4$$

The modulus of 24S-T aluminum alloy is given as $E = 10.5 \times 10^6$ psi. Hence

$$EI = 54,600 \text{ pound-inches}^2 \quad (10)$$

With beam AB

$$EI/r = 5460 \text{ inch-pounds} \quad EI/r^2 = 546 \text{ pounds} \quad EI/r^3 = 54.6 \text{ pounds per inch}$$

Consequently,

$$\left. \begin{aligned} \widehat{tt} &= 2340 \text{ pounds per inch} & \widehat{tr} &= -2146 \text{ pounds per inch} \\ \widehat{tn} &= 5170 \text{ pounds} & \widehat{nr} &= 2340 \text{ pounds per inch} \\ \widehat{rn} &= -7110 \text{ pounds} & \widehat{nn} &= 29,700 \text{ inch-pounds} \end{aligned} \right\} (11)$$

With beam AC it is convenient to assume the positive senses of the tangential force, radial force, and the moment as shown in figure 3. The positive senses of the displacements and the rotation correspond to those of the forces and the

moment. Since the radius of this beam is 20 inches, the influence coefficients have the values

$$\left. \begin{aligned} \hat{t}_t &= 292.5 \text{ pounds per inch} & \hat{t}_r &= -268.5 \text{ pound per inch} \\ \hat{t}_n &= 1292 \text{ pounds per radian} & \hat{r}_r &= 292.5 \text{ pounds per inch} \\ \hat{r}_n &= -1777 \text{ pounds per radian} & \hat{n}_n &= 14,850 \text{ inch-pounds per radian} \end{aligned} \right\} (12)$$

The Operations Table

It is possible now to consider the effect of displacing point A upon the complete structure. Since in the complete structure there is no cut through the curved beam at point A, end point A of beam AC is always displaced in the same direction and through the same distance as is end point A of beam AB. A simple "unit operation" is defined as a unit displacement in the direction of one of the three displacement coordinates (tangential, radial, rotational) while the other two displacements are held unchanged. The forces and the moment caused at point A during any unit operation can be easily calculated with the aid of the influence coefficients given in the preceding article.

In order to displace point A 1 inch in the tangential direction and in the positive sense indicated in figure 2, the following forces and moment have to be applied to point A of bar AB:

$$T = 2340 \text{ pounds} \quad R = -2146 \text{ pounds} \quad N = 5170 \text{ inch-pounds}$$

In a similar manner the forces and moments can be calculated that are necessary to displace end point A of beam AC 1 inch in the tangential direction. It is advantageous to adopt the same sign convention for the forces and moments at A independently of whether they are derived from beam AB or AC. If the sign convention of figure 2 is used, the positive unit tangential displacement of point A of beam AB corresponds to a negative unit tangential displacement of point A of beam AC in the system of coordinates shown in figure 3. Moreover

$$T_{AC} = -T_{AB} \quad R_{AC} = R_{AB} \quad N_{AC} = -N_{AB}$$

where the subscript AC refers to beam AC and the coordinate system of figure 3, and subscript AB to beam AB and

the coordinate system of figure 2. Hence the following forces and moments are necessary in order to cause point A of beam AC to displace 1 inch to the right:

$$T = 292.5 \text{ pounds} \quad R = 268.5 \text{ pounds} \quad N = 1292 \text{ inch-pounds}$$

Altogether, the following forces need be applied to point A to displace it (and consequently the ends of both bars AB and AC) 1 inch to the right:

$$T = 2632.5 \text{ pounds} \quad R = -1877.5 \text{ pounds} \quad N = 6462 \text{ inch-pounds}$$

The effect of a unit displacement in the positive radial direction can be obtained in a similar manner. Beam AB requires

$$T = -2146 \text{ pounds} \quad R = 2340 \text{ pounds} \quad N = -7110 \text{ inch-pounds}$$

With the system of coordinates of figure 2 the forces and the moments necessary to move point A of beam AC 1 inch upward are

$$T = 268.5 \text{ pounds} \quad R = 292.5 \text{ pounds} \quad N = 1777 \text{ inch-pounds}$$

Altogether,

$$T = -1877.5 \text{ pounds} \quad R = 2632.5 \text{ pounds} \quad N = -5333 \text{ inch-pounds}$$

Finally, in order to rotate end A of bar AB in the positive N direction through an angle equal to a radian, the following forces and moment must be applied to point A of bar AB:

$$T = 5170 \text{ pounds} \quad R = -7110 \text{ pounds} \quad N = 29,700 \text{ inch-pounds}$$

With the sign convention of figure 2 bar AC requires for the same rotation

$$T = 1292 \text{ pounds} \quad R = 1777 \text{ pounds} \quad N = 14,850 \text{ inch-pounds}$$

Altogether

$$T = 5462 \text{ pounds} \quad R = -5333 \text{ pounds} \quad N = 44,550 \text{ inch-pounds}$$

It might be mentioned that all the values just calculated are fictitious in the sense that they would be the actual values of the forces and moments only if the limit of proportionality of the material were higher than the stresses caused by

the forces and moments, and if the large distortions did not affect the equilibrium. If, however, both the forces and the displacements are divided by, say, 100, no objections can be raised against the validity of the data just calculated.

The results of the calculations are summarized in the table that follows:

Table 1. - Operations Table

No.	Operation	(1b) S_{xx}	(1b) V	(1b) w
[1]	$u = 1$ inch	-2632.5	+1877.5	-6462
[2]	$v = 1$ inch	+1877.5	-2632.5	+5333
[3]	$w = 1$ radian	-6462	+5333	-2632.5

The table is known as the "operations table." In it the forces and moments previously calculated appear multiplied by (-1). In other words, the forces and moments listed are not those to be applied to the structure at point A in order to cause the prescribed distortions; but their reactions, and these are applied to the structure at point A.

The operations table will be used now in order to establish the distorted shape of the structure of figure 1. It is convenient to imagine that a rigid wall is arranged behind the structure parallel to the plane of the curved beam and that by a clamping device the beam is rigidly attached to the wall at point A. Moreover, the external load may be thought of as being suspended from the clamping device.

The structure in its original, nondistorted form and the external load are thus in equilibrium, as long as the clamp and the wall are there. It is the purpose of the "relaxation procedure" to transfer the load from the "constraints" - that is, from the wall and the clamping device - to the curved beam in a number of successive operations during the course of which the beam gradually assumes its final distorted shape. A record of the individual operations is kept in the so-called "relaxation table" (table 2).

In the first row of the relaxation table the external loads are listed. In the present example the only external load is the 100-pound load which acts in the negative radial direction if, as before, the sign convention of figure 2 is adopted. Inspection of the operations table reveals that operation 2 is best suited for balancing the vertical load. Consequently, the clamping device is loosened in a manner to permit a vertical translation of section A without allowing it to translate horizontally or to rotate. Since, according to the operations table, 1-inch displacement upward would cause a vertical downward force of 2632.5 pounds to act from the structure upon the clamping device, a downward (negative) displacement $y = 100/(-2632.5) = -0.038$ inch must be undertaken. The second row of the relaxation table is now filled in with the values of the second row of the operations table multiplied by (-0.038) . It may be seen that operation just undertaken: namely, the vertical downward displacement of 0.038 inch, caused the curved beam to exert upon the constraint a vertical upward force of 100 pounds. This force balances the applied load.

Unfortunately, however, the displacement also caused the curved beam to exert upon the constraint a horizontal force of 71 pounds to the left, and a clockwise moment of 202 inch-pounds. Thus, the vertical forces are balanced, but a new unbalanced horizontal force and a new unbalanced moment are introduced. The system, of course, is in equilibrium, since the clamping device and the rigid wall - that is, the constraint - take care of the horizontal force and of the moment. The purpose of the relaxation procedure, however, is to approach gradually a state of distortions in which artificial constraints are not needed for equilibrium. It is imperative, therefore, to balance out the new unbalanced force and moment. However, before any further steps are undertaken, the clamping device must again be tightened completely.

Table 2. Relaxation Table

External force	T (lb)	R (lb)	N (in.-lb)
	0	-100	0
-0.038 x [2]	-71 -71	100 0	-202 +202
-0.027 x [1]	71 0	-51 -51	+175 -87
-0.0194 x [2]	-36 -36	51 0	-103 -130
-0.0137 x [1]	36 0	-26 -26	+88 -42
-0.0099 x [2]	-19 -19	26 0	-53 -95
-0.00722 x [1]	19 0	-14 -14	+47 48
-0.00532 x [2]	-10 -10	14 0	-28 20
-0.0038 x [1]	10 0	-7 -7	+25 45
-0.00266 x [2]	-5 -5	7 0	-14 31
0.000696 x [3]	-4 -9	4 4	-31 0
-0.00342 x [1]	9 0	-6 -2	+22 22
0.000493 x [3]	3 -3	3 3	-22 0

The unbalances are the algebraic sums of corresponding values in rows 1 and 2. They are listed in row 3, under the dashed line. The question arises now whether T or N should be balanced first. Because it is expected that the final distorted shape of the structure will involve considerable horizontal and vertical translations of section A, but only a slight rotation, it is advantageous to concentrate first on the cancellation of the unbalanced forces rather than of the moment. For this reason, operation 1 is now undertaken. The clamping device is again loosened, but now in such a manner as to permit a horizontal displacement, but at the same time to disallow any vertical translation and rotation. The ensuing horizontal motion will come to a stop when $u = 71/(-2632.5) = -0.027$ inch. Multiplication of the values listed in the first row of the operations table by -0.027 and subtraction yields the remaining unbalanced, or "residual," quantities recorded in the fifth row of the relaxation table.

According to the fifth row there are no horizontal unbalanced forces acting now upon the constraint, but an unbalanced vertical force of -51 pound appears again, which is accompanied by an unbalanced moment of -27 inch-pound. Consequently, the two displacements undertaken succeeded in reducing the unbalanced vertical force to 51 percent of its initial value, but only at the expense of introducing an unbalanced moment at the same time. The relaxation must be continued, therefore, until all the residual quantities become small enough to be neglected in engineering calculations.

The clamping device is tightened and loosened again successively, but always in a manner to permit only one single type of motion at a time. The effect of these motions upon the forces and moment is calculated in the relaxation table. After nine operations the residual forces are $T = -5$ pound, $R = 0$, $N = 31$ inch-pounds. It is thought that now it is time to permit section A to rotate. Thus, operation 3 is undertaken and recorded. This is followed by one more operation [1], and again operation [3], after which the residuals are small enough to be neglected.

Because of the great number of arithmetic operations involved in the preceding calculations, it is well to check the results. A repetition of all the computations would be very time consuming. Fortunately, this is unnecessary since a much simpler check is available. The sum of all the vertical displacements can be obtained by simple algebraic addition:

$$v_{tot} = -0.07528 \text{ inch}$$

Similarly,

$$u_{tot} = -0.05514 \text{ inch}$$

$$w_{tot} = 0.001189 \text{ radian}$$

The forces and the moment caused by each one of these total distortions can be obtained by multiplying the corresponding row in the operations table. The values computed are entered in the "check table." The algebraic sum of each column of the check table represents the final residual quantities.

For the present example these calculations are carried out in table 3. In the absence of errors the residual quantities of the last row of the check table should be identical with the residuals listed in the last row of the relaxation table. This is obviously not the case with the present example.

Table 3.- Check Table

	T (lb)	R (lb)	M (in.-lb)
External force	0	-100	0
$u = -0.05514 \text{ inch}$	145	-104	356
$v = -0.07528 \text{ inch}$	-141	198	-401
$w = 0.001189 \text{ radian}$	-8	6	-53
Residuals	-4	0	-98

Fortunately, there is no need for hunting for errors. Instead of doing so, a new set of relaxations can be carried out starting out from the residuals of the check table as the given external loading. Table 4, the second relaxation table, presents these calculations. It may be seen that after only five operations the residuals are reduced to 1 percent of the initial external load.

Table 4.- Second Relaxation Table

	T (lb)	R (lb)	N (in.-lb)
External force	-4	0	-98
-0.0022 x [3]	14	-12	98
	10	-12	0
-0.00456 x [2]	-9	12	24
	1	0	24
-0.00054 x [3]	3	-3	24
	4	-3	0
+0.00152 x [1]	-4	3	10
	0	0	-10
-0.000225 x [3]	1	-1	10
	1	-1	0

These results are now checked in the second check table (table 5). The residuals of this are substantially the same as those of the second relaxation table. The slight deviations can be explained by the inaccuracy of slide rule calculations, and by the omission of fractions of pounds and inches in all the tables.

The fact that errors need not be traced but can be eliminated in a few additional operations is considered one of the major advantages of the relaxation procedure.

Table 5.- Second Check Table

	T (lb)	R (lb)	N (in.-lb)
External force	0	-100	0
u = -0.05362 inch	141	-101	346
v = -0.07984 inch	-150	210	-426
w = -0.001776 radian	11	-9	79
Residuals	2	0	-1

Direct Solution of the Operations Table

The operations table represents a set of linear equations. It is easy to verify that table 1 can be rewritten in the form

$$\left. \begin{aligned} -2632.5 u + 1877.5 v - 6462 w + T &= 0 \\ 1877.5 u - 2632.5 v + 5333 w + R &= 0 \\ -6462 u + 5333 v - 44,550 w + N &= 0 \end{aligned} \right\} \quad (13)$$

where u, v, w are the unknown displacements and rotation, respectively, of section A; and T, R, N are the given external forces and moment, respectively. With the values of the external loads of the present example, equations (13) become:

$$\left. \begin{aligned} -2632.5 u + 1877.5 v - 6462 w &= 0 \\ 1877.5 u - 2632.5 v + 5333 w &= 100 \\ -6462 u + 5333 v - 44,550 w &= 0 \end{aligned} \right\} \quad (14)$$

These equations can be solved directly. The solution is

$$u = -0.0513 \text{ inch} \quad v = -0.0785 \text{ inch} \quad w = -0.00193 \text{ radian} \quad (15)$$

Substitution in equations (14) shows that the accuracy is better than 1 percent. The agreement of this rigorous solution with the results obtained in the relaxation procedure is also good.

It might be argued that there is no need for the relaxation procedure if the simultaneous equations represented in the operations table can be solved directly without difficulty. This argument is justified as far as the present example is concerned. In many other, more complex problems, however, when the number of simultaneous equations involved is very large, the relaxation procedure may represent the quicker and easier solution.

Calculation of the Bending Moments

The bending moment in section A can be easily calculated with the aid of the influence coefficients of bar AB given in equations (11), or those of bar AC given in equations (12). If the distortions listed in equations (15) are used, the following bending moment N_A is obtained for section A of beam AB:

$$\begin{aligned}
 N_A &= u \hat{n}t + v \hat{n}r + w \hat{n}n \\
 &= -0.0513 \times 5170 + 0.0785 \times 7110 - 0.00193 \times 29,700 \\
 &= 235.4 \text{ inch-pounds}
 \end{aligned}$$

If the displacement u and the rotation w are attributed positive signs in order to comply with the sign convention of figure 3 and equations (12), the following expression is obtained for section A of beam AB:

$$\begin{aligned}
 N_A &= 0.0513 \times 1292 + 0.0785 \times 1777 + 0.00193 \times 14,850 \\
 &= 234.4 \text{ inch-pounds}
 \end{aligned}$$

The two values differ by less than 1 percent. The difference is considered permissible since the calculations were carried out with a slide rule. The normal force T_A and the shear force R_A can be calculated in a similar manner. When the calculations are based on bar AB,

$$\begin{aligned}
 T_A &= u \hat{t}t + v \hat{t}r + w \hat{t}n \\
 &= -0.0513 \times 2340 + 0.0785 \times 2146 - 0.00193 \times 5170 \\
 &= 38.4 \text{ pounds} \\
 R_A &= u \hat{r}t + v \hat{r}r + w \hat{r}n \\
 &= +0.0513 \times 2146 - 0.0785 \times 2340 + 0.00193 \times 7110 \\
 &= -60.9 \text{ pounds}
 \end{aligned}$$

When the calculations are carried out for bar AC,

$$T_A = 0.0513 \times 292.5 + 0.0785 \times 268.5 + 0.00193 \times 1292 = 38.6$$

$$R_A = -0.0513 \times 268.5 - 0.0785 \times 292.5 - 0.00193 \times 1777 = -40.1$$

The deviation of the tensile force obtained for AB from that obtained for AC is much less than 1 percent of the load. The two shear forces add up to 401 pounds, instead of the correct 100 pounds.

The bending moment in beam AB can be calculated from equation (1). In order to get consistent results, the following values are used in the equations:

$$N = 234.9 \text{ inch-pounds} \quad T = 38.5 \text{ pounds} \quad R_{AB} = -60.4 \text{ pounds}$$

$$R_{AC} = -39.6 \text{ pounds}$$

Equation (1) becomes

$$\begin{aligned} M &= 38.5 \times 10(1 - \cos \phi) - 60.4 \times 10 \sin \phi + 234.9 \\ &= 619.9 - 385 \cos \phi - 604 \sin \phi \end{aligned}$$

Similarly, the bending moment in beam AC is:

$$\begin{aligned} M &= 38.5 \times 20(1 - \cos \phi) - 39.6 \times 20 \sin \phi + 234.9 \\ &= 1004.9 - 770 \cos \phi - 792 \sin \phi \end{aligned}$$

The bending moment diagram is shown in figure 4.

CALCULATION OF THE BENDING MOMENTS IN RINGS OF ARBITRARY SHAPE

Review of Methods of Calculation

When the shape of the median line of the frame deviates considerably from a circle or ellipse, or when there are additional internal bracing members incorporated in the frame, the classical analytic methods of calculation can seldom be used. The numerical or graphic procedures suggested by Lundquist and Burke (reference 6) and Hoff (reference 7), and the column

analogy developed by Hardy Cross and recently described for the benefit of aeronautical engineers by du Plantier (reference 8) are useful in the former case - that is, when the moments have to be determined in a closed ring without internal bracings. In the publication by Lundquist and Burke, equations are also presented for the case of a ring having one internal bracing element. It is believed that the procedures described in the present report will be found reasonably simple even when several internal bracing members are incorporated in a frame of arbitrary shape.

It will be shown in the next article how the relaxation method can be employed to calculate the bending moments in an "egg shape" frame loaded symmetrically with two equal and opposite forces. The egg shape in question is the combination of two arcs of circles and two straight lines. It is believed that the median line of every fuselage frame can be represented with sufficient accuracy by arcs of circles and straight lines.

As the determination of the influence coefficients of arcs of circles is a cumbersome task because of the small differences of large numbers involved, tables and graphs of influence coefficients have been prepared and presented for use in part IV of the present investigation (reference 5). This part IV, entitled Influence Coefficients of Curved Bars for Distortions in Their Own Plane, is intended for use in future frame calculations in the same manner as tables of trigonometric or hyperbolic functions are used.

It was found that a result of sufficient accuracy can be obtained by the relaxation method in a reasonably small number of steps only if the computer can make a good guess regarding the distorted shape of the structure. Unfortunately, it is hard to visualize the amounts of rotation the ends of the individual elements of the frame undergo. For this reason, a second type of numerical approach is presented. This uses the operations table of the relaxation method as its starting point and reaches the answer to the problem through a number of solutions of two or three simultaneous linear equations. The procedure is denoted as the "growing unit" procedure. It is applied to the present problem and gives substantially the same results as the relaxation method.

For a check of the results the problem was also solved by the graphic procedure of reference 7. In addition, the system of simultaneous equations represented by the operations table was solved with the aid of the matrix calculus. This

latter approach is discussed in the appendix, but the results of the calculations are presented in this chapter for the purpose of a comparison with the results reached by the various other methods. The agreement is found to be good.

Finally, the results of one more comparison are given. It may be seen from reference 5 that the influence coefficients calculated on the basis of inextensional deformations differ considerably from those obtained when the extensions and the shearing deformations of the curved bars are taken into account. In the last solution of the present problem the operations table was recalculated using the "inextensional" influence coefficients. It turned out that the bending moment distribution obtained through a matrix solution of this modified operations table was practically the same as that calculated earlier on the basis of the more accurate operations table.

In all the problems discussed in this report the cross-sectional dimensions of the ring are considered small as compared to the radius of curvature of the ring. Consequently, the distortions of the ring elements can be calculated from formulas based on the linearity of the stress distribution rather than the hyperbolic law valid for curved beams. Similarly, in problems involving shear flow the lever arm of the shear flow - that is, the distance of the sheet from the neutral axis of the ring section - is neglected.

Basic Data of the Egg-Shape Ring

The dimensions of the ring are given in figure 5. The shape of the median line is taken from reference 7 and can be obtained by drawing the two circles of 20-inch and 25-inch radius, respectively, with their centers 25 inches apart, and the common tangents to the two circles. It follows from the geometry of the figure that the angle subtended by arc AB is 78.46° , and that subtended by arc CD is 101.54° .

It is assumed that the frame is manufactured by bending an aluminum alloy I-section to the required shape. The area of the I-section is 0.610 square inch, its maximum moment of inertia 0.952 inch^4 . The deformations of the ring under the loads depend upon the bending, extensional, and shearing rigidities of its section. It was shown in reference 5 that the shearing rigidity has a considerable effect upon the magnitude of the influence coefficients. An "effective shear area" A^* was, therefore, defined in such a manner that the strain

energy in shear stored in an element, of the beam of an infinitesimal length dL could be calculated from the simple formula

$$dU_{\text{shear}} = (V^2 / 2EA^*)dL$$

where V is the shear force in the section and E is Young's modulus. The ratio A^*/A , where A is the actual cross-sectional area of the beam, was denoted by ξ and may be termed the "shear rigidity factor." It depends upon the shape of the cross section and the value of G/E , where G is the shear modulus. In reference 5, formulas were developed for the calculation of the shear rigidity factor for some representative cross-sectional shapes.

In the case of the I-section shown in figure 5, the value of ξ can be calculated from equation (10) of reference 5. The computation gives $A^* = \xi A = 0.081$ square inch. It may be noted that with the I-section in question the effective shear area is almost exactly the area of the web multiplied by the ratio G/E .

In the calculations that follow, E is assumed to be 10.5×10^6 psi. With this value EI becomes 10^7 pound-inches². The ratio G/E was taken as 0.385.

Calculation of the Influence Coefficients

Since all computational work was carried out on eight bank calculating machines, not more than eight figures were kept in the calculations.

Arc AB.— The angle subtended by the arc of circle was denoted β in reference 5. The parameter ξ was discussed in the preceding article. In the case of arc AB the values are:

$$\beta = 1.3694384 \text{ radians}$$

$$\xi = A^*/A = 0.1331058$$

The section-length parameter γ was defined in equation (18) of reference 5. In the case of arc AB

$$\gamma = AL^2/I = 480.8619$$

where L is the length of the arc. The parameters κ and λ were defined in equation (19) of reference 5. Substitution yields

$$\kappa = 1 + (\beta^2/\gamma) + (\beta^2/\gamma\xi) = 1.0332$$

$$\lambda = 1 + (\beta^2/\gamma) - (\beta^2/\gamma\xi) = 0.9746$$

The influence coefficients are obtained as ratios of the numerator and denominator determinants. First, the denominator is computed from equation (21a) of reference 5:

$$\Delta = 0.00521084 r^2$$

Equations (21b) to (21g) of reference 5 yield the numerators:

$$\Delta_{nn} = 0.01986728 EI r$$

$$\Delta_{rn} = -0.04079544 EI$$

$$\Delta_{tn} = 0.02730762 EI$$

$$\Delta_{rr} = 6.13958066 (EI/r)$$

$$\Delta_{tr} = -0.14320247 (EI/r)$$

$$\Delta_{tt} = 0.19804284 (EI/r^2)$$

The influence coefficients are now obtained by division:

$$\widehat{nn} = \Delta_{nn}/\Delta = 3.81268 (EI/r)$$

$$\widehat{rn} = \Delta_{rn}/\Delta = -7.82896 (EI/r^2)$$

$$\widehat{tn} = \Delta_{tn}/\Delta = 5.24054 (EI/r^2)$$

$$\widehat{rr} = \Delta_{rr}/\Delta = 26.7866 (EI/r^3)$$

$$\widehat{tr} = \Delta_{tr}/\Delta = -27.4816 (EI/r^3)$$

$$\widehat{tt} = \Delta_{tt}/\Delta = 38.0059 (EI/r^3)$$

(16)

A unit displacement is assumed as 10^{-4} inch, and a unit rotation as 10^{-4} radian, in order to obtain convenient numbers in the computations. Hence the values listed must be multiplied by 10^{-4} . With

$$EI/r = 50 \times 10^4 \text{ inch-pounds}$$

$$EI/r^2 = 2.5 \times 10^4 \text{ pounds}$$

$$EI/r^3 = 0.125 \times 10^4 \text{ pounds per inch}$$

the final values of the influence coefficients become:

$$\left. \begin{aligned} \bar{nn} &= 190.634 \text{ inch-pounds per } 10^{-4} \text{ radian} \\ \bar{rn} &= -19.5724 \text{ pounds per } 10^{-4} \text{ radian} \\ \bar{tn} &= 13.1014 \text{ pounds per } 10^{-4} \text{ radian} \\ \bar{rr} &= 3.34833 \text{ pounds per } 10^{-4} \text{ inch} \\ \bar{tr} &= -3.43520 \text{ pounds per } 10^{-4} \text{ inch} \\ \bar{tt} &= 4.7507 \text{ pounds per } 10^{-4} \text{ inch} \end{aligned} \right\} (17)$$

Straight bar BC. - For the straight bar simple formulas are given in equations (25), reference 5. Symbol ξ was assumed to be 0.13305785. As long as the same value of ξ is taken consistently in the calculation of the influence coefficients of any one portion of the frame, it is of little importance whether exactly the same value is used for all the portions. A change in ξ from one portion to another is equivalent to a slight variation in the cross-sectional shape. The difference in the two values of ξ given corresponds to a change in the cross-sectional shape that is well within manufacturing tolerances. The following data of the straight bar are needed:

$$L = 24.4949 \text{ inches} \quad Y = 385.14588$$

Equations (25) of reference 5 give:

$$\left. \begin{aligned} \bar{nn} &= 137.232 \text{ inch-pounds per } 10^{-4} \text{ radian} \\ \bar{rn} &= -8.10267 \text{ pounds per } 10^{-4} \text{ radian} \\ \bar{tn} &= 0.66158 \text{ pounds per } 10^{-4} \text{ radian} \\ \bar{rr} &= 0.66158 \text{ pound per } 10^{-4} \text{ inch} \\ \bar{tr} &= 0 \\ \bar{tt} &= 26.2058 \text{ pounds per } 10^{-4} \text{ inch} \end{aligned} \right\} (18)$$

Arc CD:

$$\beta = 1.7721543 \text{ radians}$$

$$\xi = 0.13305785$$

$$Y = 1259.961$$

$$k = 1.021226$$

$$\lambda = 0.983760$$

The numerator and denominator determinants were calculated as before. The influence coefficients have the following values:

$$\begin{aligned} \bar{n}_n &= 3.778386 (EI/r^2) \\ \bar{r}_n &= -6.911804 (EI/r^2) \\ \bar{t}_n &= 3.279169 (EI/r^2) \\ \bar{r}_r &= 19.38230 (EI/r^3) \\ \bar{t}_r &= -13.89515 (EI/r^3) \\ \bar{t}_t &= 13.70964 (EI/r^3) \end{aligned} \quad (19)$$

With the values

$$EI/r = 40 \times 10^4 \text{ inch-pounds}$$

$$EI/r^2 = 1.6 \times 10^4 \text{ pounds}$$

$$EI/r^3 = 0.064 \times 10^4 \text{ pounds per inch}$$

the influence coefficients become:

$$\left. \begin{aligned}
 \bar{n}n &= 151.135 \text{ inch-pounds per } 10^{-4} \text{ radian} \\
 \bar{r}n &= -11.05889 \text{ pounds per } 10^{-4} \text{ radian} \\
 \bar{t}n &= 5.24667 \text{ pounds per } 10^{-4} \text{ radian} \\
 \bar{r}r &= 1.24047 \text{ pounds per } 10^{-4} \text{ inch} \\
 \bar{t}r &= -0.88929 \text{ pounds per } 10^{-4} \text{ inch} \\
 \bar{t}t &= 0.8774 \text{ pound per } 10^{-4} \text{ inch}
 \end{aligned} \right\} (20)$$

The Influence Coefficients at the Fixed End

In the example of the preceding chapter, equilibrium had to be established only at point A of figure 1, since at the fixed ends B and C of the arcs any reaction forces and moments were available. For this reason, only point A was balanced in the relaxation procedure, and the effect of displacements of point A upon the fixed ends of the arcs was not investigated. The situation is different in the case of the frame shown in figure 5. There three points A, B, and C are displaced in the relaxation procedure. Consequently, the forces and moments caused, for example, at A and C by displacements of point B must be determined. As in the previous example, only a single motion is undertaken at a time in the relaxation procedure. For instance, point B is displaced radially and at the same time it is prevented from moving tangentially and from rotating. Simultaneously, points A and C are considered rigidly fixed in their positions.

The influence coefficients calculated up to this point represent the forces and moments necessary at the point that moves, while the other end of the curved or straight beam is considered rigidly fixed. Simple equilibrium considerations suffice for the calculation of the reactions at the fixed end, when the forces and the moment at the movable end are known. These reactions also can be reduced to the influence coefficient form. In order to distinguish between the two groups of influence coefficients, the former are denoted as the influence coefficients for the movable end, the latter as those for the fixed end. In the formulas the subscript M refers to the former, subscript F to the latter. If there is no possibility for misunderstanding, as in the preceding example, the subscript may be omitted.

In determining the sign of the forces and moments the beam convention shown in figure 6a is used.

The influence coefficients at the fixed end were calculated with the aid of equations (27), (28), and (29) of reference 5. For arc AB their values are:

$$\left. \begin{aligned} \widehat{nn}_F &= 0.33433 (EI/r) \\ \widehat{rn}_F &= -3.56887 (EI/r^2) \\ \widehat{tn}_F &= 8.71889 (EI/r^2) \\ \widehat{rr}_F &= 21.5691 (EI/r^3) \\ \widehat{tr}_F &= -31.7417 (EI/r^3) \\ \widehat{tt}_F &= 34.5276 (EI/r^3) \end{aligned} \right\} \quad (21)$$

Substitution gives

$$\left. \begin{aligned} \widehat{nn}_F &= 16.7165 \text{ inch-pounds per } 10^{-4} \text{ radian} \\ \widehat{rn}_F &= -8.92216 \text{ pounds per } 10^{-4} \text{ radian} \\ \widehat{tn}_F &= 21.797 \text{ pounds per } 10^{-4} \text{ radian} \\ \widehat{rr}_F &= 2.69614 \text{ pounds per } 10^{-4} \text{ inch} \\ \widehat{tr}_F &= -3.96771 \text{ pounds per } 10^{-4} \text{ inch} \\ \widehat{tt}_F &= 4.31595 \text{ pounds per } 10^{-4} \text{ inch} \end{aligned} \right\} \quad (22)$$

For the straight portion BC there is obtained:

$$\left. \begin{aligned} \widehat{nn}_F &= -81.242 \text{ inch-pounds per } 10^{-4} \text{ radian} \\ \widehat{rn}_F &= 8.10267 \text{ pounds per } 10^{-4} \text{ radian} \\ \widehat{tn}_F &= 0 \\ \widehat{rr}_F &= -0.66158 \text{ pounds per } 10^{-4} \text{ inch} \\ \widehat{tr}_F &= 0 \\ \widehat{tt}_F &= 26.2058 \text{ pounds per } 10^{-4} \text{ inch} \end{aligned} \right\} \quad (23)$$

For arc CD, the influence coefficients for the fixed end will not be needed in the relaxation procedure. However, it is convenient to have them for checking purposes:

$$\left. \begin{aligned}
 \widehat{nn}_F &= 37.649 \text{ inch pounds per } 10^{-4} \text{ radian} \\
 \widehat{rn}_F &= -7.3524 \text{ pounds per } 10^{-4} \text{ radian} \\
 \widehat{tn}_F &= 9.7861 \text{ pounds per } 10^{-4} \text{ radian} \\
 \widehat{rr}_F &= 1.119416 \text{ pounds per } 10^{-4} \text{ inch} \\
 \widehat{tr}_F &= -1.03755 \text{ pounds per } 10^{-4} \text{ inch} \\
 \widehat{tt}_F &= 0.695839 \text{ pound per } 10^{-4} \text{ inch}
 \end{aligned} \right\} (24)$$

Operations Table

In the operations table the forces and moments caused by the individual operations are listed. An individual operation consists of a displacement, or rotation, of one point of the frame while all the other end points of the individual arcs considered are held rigidly fixed. The operations table can be easily established once the influence coefficients are known.

Care must be exercised in the matter of signs. The beam convention is not suitable for use in the operations table, since according to it the signs of T and N depend upon whether T and N act at the right end or the left end of the arc. For this reason, the rigid frame convention shown in figure 6b will be used. In this convention clockwise moments are positive at either end of the arc. Similarly, a tangential force is positive if its direction corresponds to proceeding in a clockwise sense along the arc. The radial force is positive when it acts toward the center of curvature. Moreover, the operations table is set up by considering the effect of each operation upon the constraint rather than upon the beam. In other words, the table lists the forces exerted upon the imaginary supports (or constraints) when one of the points is displaced.

In the particular problem at hand, points A and D will certainly remain in the plane of symmetry when the distortions of the frame are caused by the symmetric loading shown in figure 5. It follows further from the symmetry

that the horizontal tangents at A and D will remain horizontal. On the other hand, the distance between A and D will change under the loading. It suffices, therefore, for describing all possible relative displacements to consider the beam as rigidly fixed at D and to allow section A a single degree of freedom of motion; namely, that of a vertical displacement. (See, for instance, reference 2.)

In the first row of the operations table (table 6) the effect of a radial displacement of point A is listed. From equations (17) the radial force acting upon beam AB in section A is 3.34833 pounds when section A is displaced the unit distance (10^{-4} in.) in the positive radial direction. Consequently, the reaction of this force; that is, -3.34833 pounds will be exerted upon the constraint at A. The effect of the same motion upon the fixed end of the beam at section B is given by the influence coefficients for the fixed end contained in equations (22). These influence coefficients must again be multiplied by -1 in order to obtain the effect of the displacement upon the constraint. The final values are:

$$R_A = 3.92216 \text{ inch-pounds} \quad R_B = -2.69614 \text{ pounds} \quad T_B = 3.96771 \text{ pounds}$$

With these forces the change from the beam convention used for the influence coefficients to the rigid frame convention used in the operations table did not entail any changes in sign, as may be seen from a comparison of figures 6a and 6b. It may be noted that a positive radial deflection of the beam at point A caused a negative radial force to act upon the constraint at A. This could be expected, since an upward force is felt if the movable end of the elastic cantilever beam shown in figure 6a is pushed down.

The second row of the operations table shows the effect of a rotation of the section at B. If end section B of beam AB is rotated through a positive angle of 10^{-4} radian, the forces and the moment caused at A are given by the influence coefficients for the fixed end (equations (22)). Only the value of R_A is listed in the operations table, since it is not necessary to balance N_A and T_A . Because of the symmetry of structure and loading, the point symmetrically situated to B would always be displaced in the same manner as B is, and its displacement would cause a tensile force and a moment which would balance N_A and T_A . (See also reference 9.) The effect of the rotation of section B of beam BC upon the fixed end at C is represented by the influence coefficients of equations (23). Of course, all these coefficients are

multiplied by -1 before entering them in the operations table.

The effect of a rotation of section B upon the forces and the moment at B is given by combinations of the influence coefficients for the movable end of beams AB and BC. It must not be forgotten, however, that in the calculation the rigid frame convention must be used in determining the correct sign of the influence coefficients. According to figures 6a and 6b at the right end of the beam AB, the two sign conventions are identical, but at the left end of beam BC, only the signs of the radial force are the same, those of the tangential force and the moment are opposed. (See fig. 7.) Displacements and rotations are considered to have the same positive sense as the corresponding forces and moment, respectively. If the multiplication by -1 is also carried out in order to obtain the forces and the moment acting upon the constraints, the entire calculation can be given in the following lines:

1.	Influence coefficient for						
	beam AB	190.634	-19.5724	13.1014			
2.	Influence coefficient for						
	beam BC	137.232	-8.10267	0			
3.	Row (2) multiplied by -1 to ob-						
	tain coefficients corresponding						
	to positive rotation, according						
	to rigid frame convention,	-137.232	8.10267	0			
4.	Signs of preceding line changed						
	to conform with rigid frame con-						
	vention for forces and moment,	137.232	8.10267	0			
5.	Sum of rows (1) and (4)	327.866	11.4697	13.1014			
6.	Row (5) multiplied by -1 to give						
	effect upon constraint,	-327.866	-11.4697	-13.1014			

Since the calculation of the other items in the operations table is carried out according to the same principles, further details are not given.

Solution of the Problem by Relaxation

The purpose of the relaxations is to find such multipliers for operations 1 to 7, as result in $R_A = 500$ pounds and in vanishing values for all the forces and moments N_B to T_C . The value of 500 pounds is stated instead of 1000 pounds, since because of the symmetry only one-half of the structure is considered. There is no need for balancing the forces and moments N_A , T_A , N_D , and T_D , since they are automatically balanced when the left-hand half of the ring undergoes distortions symmetric to those undertaken with the right-hand half. Moreover, because of the conditions of equilibrium of the external forces, a residual force $R_D = 500$ must be obtained automatically at point D when all the other residuals are brought down to negligibly small quantities. This force is then balanced by one-half of the 1000-pound external force at D.

In working out the present problem it was thought advantageous to begin with a rough guess as to the final shape of distortions of the frame. It was convenient to consider section D as rigidly fixed and to assume reasonable amounts of radial and tangential displacements for each of points A, B, and C. The amounts chosen are given below together with the forces and moments caused by their simultaneous occurrence. As may be seen, the radial and tangential displacements listed correspond to displacements of points B and C upward and to the left, and to an upward displacement of point A. The rotation of B was assumed to be clockwise, that of C counterclockwise. The forces and moments were obtained by adding up corresponding values of the operations table after the rows were multiplied by the factors chosen. The distortions are:

$$v_A = -100 \text{ units} \quad w_B = 2 \text{ units} \quad v_B = 50 \text{ units} \quad u_B = -30 \text{ units}$$

$$w_C = -0.5 \text{ units} \quad v_C = 50 \text{ units} \quad u_C = -31 \text{ units}$$

The forces and moments resulting from the distortions are:

R_A	N_B	R_B	T_B	N_C	R_C	T_C
98.839	-145.67	26.132	-134.9	-368.6	-16.77	11.57

The set of distortions listed can be considered as a "group displacement." It will be denoted as operation [8]. In the course of the relaxations it is advantageous to make use of other combinations of the elementary operations. Two such combinations were used in the relaxation table (table 7). They are listed below.

Operation [9]

	R_A	N_B	R_B	T_B	N_C	R_C	T_C
-100($u_B + u_C$)	-396.771	1310.14	-343.52	475.28	524.667	88.929	87.75

Operation [10]

[9] - 120 v_A	5.03	239.5	-19.98	-0.85	524.667	88.929	87.75
-----------------	------	-------	--------	-------	---------	--------	-------

In operation [9] the shape and the length of the straight beam (beam BC) do not change. Operations of this kind are denoted as "block displacements." In a block displacement part of the structure undergoes a rigid body displacement.

Table 7. First Relaxation Table

Operation	R_A	N_B	R_B	T_B	N_C	R_C	T_C
0.3 [9]	98.839 -119.03	-145.67 393.04	26.132 -103.06	-134.9 142.58	-368.6 157.4	-16.77 26.68	11.57 26.33
-25 [3]	-20.19 67.40	247.37 -286.74	-76.93 100.25	7.58 -85.88	-211.2 202.6	9.91 -16.54	37.90 0
-2 [4]	47.21 -7.94	-39.37 26.20	23.32 -6.87	-78.20 61.90	-8.6 0	-6.63 0	37.90 -52.41
0.1 [10]	39.27 0.50	-13.17 23.95	16.87 -2.00	-16.29 -0.09	-8.6 52.5	-6.63 8.89	-14.51 8.72
0.15 [5]	39.77 0	10.78 -9.19	14.45 -1.22	-16.38 0	43.9 -43.3	2.26 -0.44	-5.79 -0.79
5 [1]	39.77 -16.74	1.59 44.6	13.23 -13.48	-16.38 19.84	0.6 --	1.82 --	-6.58 --
0.14 [2]	23.03 1.25	46.2 -45.9	-0.25 1.61	13.46 -1.83	0.6 -8.57	1.82 1.13	-6.58 0
-0.028 [5]	24.28	0.3 1.71	1.86 0.23	1.63 0	-8.0 8.1	2.95 0.08	-6.58 0.15
-0.15 [7]	24.28	2.0 0	2.1 0	1.63 -3.93	0.1 0.5	3.03 0.08	-6.43 4.06
	24.28	2.0	2.1	-2.3	0.6	3.1	-2.37

Instead of balancing the largest residual force at each stage, it was found more convenient to adopt a particular procedure. After operation [8] was completed, an attempt was made to reduce all the residuals but R_A to negligibly small quantities, while keeping R_A as large as possible. The purpose was to establish a distorted shape corresponding to any finite radial force at A and negligibly small residuals at points B and C. Division of 500 pounds by the radial force at A so obtained yields the factor by which the complete set of operations undertaken must be multiplied in order to obtain the final displacements of the frame under the load specified.

Table 8.- Check Table

Operation	R_A	N_B	R_B	T_B	N_C	R_C	T_C
-107 v_A	358.271	-954.671	288.487	-424.545			
2.14 w_B	19.093	-701.633	24.545	-28.037	-131.058	17.340	0
25 v_B	-67.404	286.742	-100.248	85.880	-202.567	16.540	0
-72 u_B	-285.675	943.301	-247.334	2228.875	0	0	-1886.818
-0.378 w_C		23.149	3.063	0	109.003	1.117	1.983
50 v_C		405.134	33.079	0	-147.811	-95.103	-44.465
-71.15 u_C		0	0	-1864.543	373.301	63.273	1926.977
Sum	24.286	2.022	1.592	-2,369	0.868	3.167	-2.322

In table 7 the objective was attained to an accuracy of 13 percent in nine operations following operation [8]. Before the relaxation was continued, a check table (table 8) was then established. Some slight differences were found in the results, and the residuals of the check table were further relaxed in 11 more operations (in table 9).

Table 9.- Second Relaxation Table

Operation	R _A	N _B	R _B	T _B	N _C	R _C	T _C
Results of Check Table 2 [6]	24.286	2.022 16.205	1.592 1.323	-2.369 0	0.868 -5.912	3.167 -3.804	-2.322 -1.779
-0.15 [7]	24.286	18.227 0	2.915 0	-2.369 -3.931	-5.044 +0.787	-0.637 0.133	-4.101 4.062
1.4 [1]	24.286 -4.688	18.227 12.491	2.915 -3.775	-6.300 5.555	-4.257	-0.504	-0.039
0.094 [2]	19.598 0.837	30.718 -30.819	-0.860 1.078	-0.745 -1.231	-4.257 -5.757	-0.504 0.762	-0.039
-0.0347 [5]	20.435	-0.101 2.125	0.218 0.281	-1.976 0	-10.014 10.006	0.258 0.103	-0.039 +0.182
-0.025 [4]	20.435 -0.099	2.024 0.328	0.499 -0.086	-1.976 0.774	-0.008 0	0.361 0	0.143 -0.655
0.2 [1]	20.336 -0.669	2.352 1.784	0.413 -0.539	-1.202 0.793	-0.008	0.361	-0.512
0.0126 [2]	19.667 0.112	4.136 -4.136	-0.126 0.144	-0.409 -0.165	-0.008 -0.77	0.361 0.102	-0.512 0
-0.0027 [5]	19.779	0 +0.165	0.018 +0.022	-0.574 0	-0.778 +0.779	0.463 +0.008	-0.512 0.014
0.1 [1]	19.779 -0.335	0.165 0.892	0.040 -0.270	-0.574 0.397	0.001	0.471	-0.498
0.002 [2]	19.444 0.017	1.057 -0.656	-0.230 0.023	-0.177 -0.026	0.001 -0.122	0.471 0.016	-0.498
Results of a second check	19.461 19.471	0.401 0.380	-0.207 -0.199	-0.203 -0.266	-0.121 -0.124	0.437 0.487	-0.498 -0.445

After these the greatest residual force at points B and C was 2.5 percent of the radial force obtained at point A. A second check, details of which are not given in this report, resulted in the residuals listed in the last row of table 9. Since the radial force at point A had the value

$R_A = 19.471$ pounds
 all the operations had to be multiplied by the factor
 $500/19.471 = 25.679$

in order to obtain the final deflected shape of the frame.
 The final deflections are given below:

$$\left. \begin{aligned} v_A &= -0.2704 \text{ inch} & w_B &= 0.005774 \text{ radian} & v_B &= 0.06420 \text{ inch} \\ u_B &= -0.18495 \text{ inch} & w_C &= -0.0010667 \text{ radian} & v_C &= 0.13353 \text{ inch} \\ u_C &= -0.18309 \text{ inch} \end{aligned} \right\} (25)$$

It may be seen that the first guess for the deflected shape, as given in operation [8], differed considerably from the final shape. Nevertheless, only a comparatively small number of relaxations was required for the solution of the problem. The deflected shape is shown in figure 8. Next, the bending moment distribution is calculated. For this purpose, the tangential force and the bending moment at point A are needed. These are caused by the displacements (and rotations) of points A and B, and can be calculated with the aid of the influence coefficients given in equations (17) and (22). The calculation follows:

Caused by: $v_A=10^{-4}$ $v_A=-0.2704$ $w_B=10^{-4}$ $w_B=0.005774$ $v_B=10^{-4}$

N_A	-19.5724	52924	16.7165	965	-8.92216
T_A	-3.4352	9288.78	21.7972	1258.57	-3.96771

Caused by: $v_B=0.06420$ $u_B=10^{-4}$ $u_B=-0.18495$ Sum

N_A	-5728	21.7972	-40314	7847 inch-pounds
T_A	-2547.27	4.31595	-7982.35	17.73 pounds

Since influence coefficients were used in the calculation of the moment and the tensile force at A, the values obtained represent the action upon the curved beam; and the signs are in accordance with the beam convention. It must be

noted, however, that the signs of the displacements used in the preceding calculations also had to be taken according to the beam convention. In the present case, this requirement did not cause any change in the signs of the displacements obtained from the relaxations, since the displacements and the rotation at the right end of the curved beam, and the radial displacement at the left end have the same sign for the two conventions.

With the values of N_A and T_A so obtained, and with $R_A = -500$ pounds, the bending moments were calculated for several points along the median line of the ring. The moment distribution is shown in figure 9. The bending moment, the radial force, and the tangential force at point D were also calculated from the influence coefficients in order to obtain a check of the accuracy of the calculations. Care must be taken to transform the signs of the displacements at point C to conform with the beam convention. The computations follow:

Caused by: $w_C = 10^{-4}$ $w_C = 0.0010667$ $v_C = 10^{-4}$ $v_C = 0.13353$

N_D	137.649	40.2	-7.3524	-9818
R_D	17.3524	-78	1.119416	1495
T_D	5.7887	104.39	-1.03755	-1385.44

Caused by: $u_C = 10^{-4}$ $u_C = 0.18309$ $v_C = 0$ $v_C = 0$ Sum

N_D	9.7861	17917	8501	inch-pounds
R_D	-1.03755	1900	483	pounds
T_D	0.695839	1274.01	-7.04	pounds

These values show that the accuracy is sufficient for engineering purposes. The radial force obtained deviates about 3.4 percent from the actual -500 pounds. The bending moment is shown as 9088 inch-pounds in figure 9. The deviation of the average of the two values from any one of the values given is 3.3 percent. The forces T_D and T_A should add up to zero. In reality, their sum is 10.69 pounds, which is about 2.1 percent of 500 pounds—that is, of one-half the applied load.

The Growing Unit Procedure

In the growing unit procedure the units of the ring are combined gradually into units of increasing size until finally the entire ring becomes a single unit. In each step of the procedure two or three simultaneous linear equations have to be solved. The growing unit procedure has been developed, since in many problems the relaxation procedure is too slowly convergent. This is true particularly when the shape or the loading of the frame does not allow a good guess regarding the shape of distortions.

When this procedure is applied to the egg-shape frame loaded by the equal and opposite forces at A and D in figure 5, it can again be assumed that section D is fixed in the plane, and section A is only free to move in a vertical direction. The first step in the procedure is then to combine beams AB and BC into one unit AC. This can be accomplished by determining u_B , v_B , and w_B so as to cause N_B , R_B , and T_B to vanish when in turn a unit radial displacement, a unit tangential displacement, and a unit rotation are undertaken individually at points A and C.

In the present problem section A moves only radially. The forces and the moment acting at B when $v_A = 10^{-4}$ inch are given in the second, third, and fourth columns of the first row of the operations table (table 6). The forces and the moment caused by the unknown displacements and rotation at B can be obtained from the second, third, and fourth rows of the operations table. The requirements of the vanishing of the forces and the moment at B can then be written in the form:

$$\left. \begin{aligned} -327.866 w_B + 11.4697 v_B - 13.1014 u_B &= -8.92216 \\ 11.4697 w_B - 4.00991 v_B + 3.4352 u_B &= 2.69614 \\ -13.1014 w_B + 3.4352 v_B - 30.9566 u_B &= -3.96771 \end{aligned} \right\} (26)$$

Solution of the equations gives:

$$\begin{aligned} w_B &= 0.003449289 \times 10^{-4} \text{ radian} \\ v_B &= -0.612145 \times 10^{-4} \text{ inch} \\ u_B &= 0.05878271 \times 10^{-4} \text{ inch} \end{aligned}$$

The displacements found give rise to forces and a moment at C, which can be calculated from the values in the second, third, and fourth rows and the last three columns of the operations table:

$$\left. \begin{aligned} N_c &= 4.748767 \text{ inch-pounds} \\ R_c &= -0.3770343 \text{ pound} \\ T_c &= 1.540448 \text{ pounds} \end{aligned} \right\} \quad (27)$$

In order to be able to balance out the forces and the moment at C as given in equations (27), section C must be displaced and rotated. During these motions; however, no unbalances must appear in section B. In the next step of the calculations, therefore, section C will be in turn rotated, displaced radially, and displaced tangentially, and in each case values of w_B , v_B , u_B will be calculated so as to cause N_B , R_B , and T_B to vanish. When section C is rotated through a positive angle of 10^{-4} radian, the operations table gives:

$$\left. \begin{aligned} -327.866 w_B + 11.4697 v_B - 13.1014 u_B &= 61.242 \\ 11.4697 w_B - 4.00991 v_B + 3.4352 u_B &= 8.10267 \\ -13.1014 w_B + 3.4352 v_B - 30.9566 u_B &= 0 \end{aligned} \right\} \quad (28)$$

It may be seen that the left-hand side terms of equations (28) are identical with those of equations (26). Solution of equations (28) yields

$$\left. \begin{aligned} w_B &= -0.28372447 \times 10^{-4} \text{ radian} \\ v_B &= -3.0160675 \times 10^{-4} \text{ inch} \\ u_B &= -0.2146168 \times 10^{-4} \text{ inch} \end{aligned} \right\} \quad (29)$$

These displacements cause forces and a moment to appear in section C. Their values may be calculated with the aid of the operations table as before:

$$\left. \begin{aligned} N_c &= 41.814055 \text{ inch-pounds} \\ R_c &= -4.29430 \text{ pounds} \\ T_c &= -5.624205 \text{ pounds} \end{aligned} \right\} (30)$$

In addition, forces and a moment are caused at C by the unit rotation of C itself (while sections B and D are held fixed). These quantities may be taken directly from the operations table:

$$\begin{aligned} N_c &= -288.367 \text{ inch-pounds} \\ R_c &= -2.95622 \text{ pounds} \\ T_c &= -5.24667 \text{ pounds} \end{aligned}$$

Consequently, a unit rotation at C, together with the motions at B required for N_B , R_B , T_B to vanish, gives rise to the following forces and moment at C:

$$\left. \begin{aligned} N_c &= -246.55294 \text{ inch-pounds} \\ R_c &= -7.25052 \text{ pounds} \\ T_c &= -10.870875 \text{ pounds} \end{aligned} \right\} (31)$$

The effect of a unit radial and a tangential displacement of C, respectively, upon the forces and the moment at C can be calculated in an analogous manner. Again, the left-hand side members of the equations are identical with those of equations (26) and (28). The right-hand-side members have the values

$$-8.10267, -0.66158, \text{ and } 0$$

when C undergoes a unit radial displacement, and

$$0, 0, \text{ and } -26.2058$$

when C undergoes a unit tangential displacement. Solution of the equations gives

$$\left. \begin{aligned} w_B &= 0.03369378 \times 10^{-4} \text{ radian} \\ u_B &= 0.2753198 \times 10^{-4} \text{ inch} \\ v_B &= 0.01629283 \times 10^{-4} \text{ inch} \end{aligned} \right\} (32)$$

when C undergoes a unit radial displacement, and

$$\left. \begin{aligned} w_B &= -0.01039843 \times 10^{-4} \text{ radian} \\ u_B &= 0.7726881 \times 10^{-4} \text{ inch} \\ v_B &= 0.9366781 \times 10^{-4} \text{ inch} \end{aligned} \right\} (33)$$

when C undergoes a unit tangential displacement,

The forces and moments caused at C by these displacements are:

$$\left. \begin{aligned} N_C &= -4.29430 \text{ inch-pounds} \\ T_C &= 0.426967 \text{ pound} \\ R_C &= 0.4551558 \text{ pound} \end{aligned} \right\} (34)$$

when C undergoes a unit radial displacement, and

$$\left. \begin{aligned} N_C &= -5.624205 \text{ inch-pounds} \\ R_C &= 0.426967 \text{ pound} \\ T_C &= 24.5464 \text{ pounds} \end{aligned} \right\} (35)$$

when C undergoes a unit tangential displacement.

The effect of the motion of C upon the forces and the moment at C (considering B and D as rigidly fixed) is again taken directly from the operations table:

$$\begin{aligned} N_C &= -2.95622 \text{ inch-pounds} \\ R_C &= -1.90205 \text{ pounds} \\ T_C &= -0.88929 \text{ pound} \end{aligned}$$

when C undergoes a unit radial displacement, and

$$\begin{aligned} N_C &= +5.24667 \text{ inch-pounds} \\ R_C &= -0.88929 \text{ pound} \\ T_C &= -27.0833 \text{ pounds} \end{aligned}$$

when C undergoes a unit tangential displacement.

Altogether, the forces and moments at C become, when C is displaced radially and tangentially, respectively, through a positive unit distance:

$$\left. \begin{aligned} N_C &= -7.25052 \text{ inch-pounds} \\ R_C &= -1.4468942 \text{ pounds} \\ T_C &= -0.462323 \text{ pound} \end{aligned} \right\} (36)$$

in the case of a radial displacement, and

$$\left. \begin{aligned} N_C &= -10.870875 \text{ inch-pounds} \\ R_C &= -0.462323 \text{ pounds} \\ T_C &= -2.5369 \text{ pounds} \end{aligned} \right\} (37)$$

in the case of a tangential displacement.

Equations (31), (36), and (37) give the forces and the moment caused in section C by the three possible motions of section C. These values correspond to such distortions of the ring as do not entail unbalanced forces or moments anywhere along the ring except in the end sections A and D. The values of the motions at C must now be determined in such manner as to balance out the forces and the moment caused at C by the unit radial displacement of A. These unbalanced forces are listed in equations (27). The requirements that N_C , R_C , and T_C must vanish can be stated in the form of the following three simultaneous equations:

$$\left. \begin{aligned} -246.55294 w_C - 7.25052 v_C - 10.870875 u_C &= +4.748767 \\ -7.25052 w_C - 1.4468942 v_C - 0.462323 u_C &= +0.3770343 \\ -10.870875 w_C - 0.462323 v_C + 2.5369 u_C &= -1.540448 \end{aligned} \right\} (38)$$

The solution of these equations is

$$\left. \begin{aligned} w_C &= 0.003849891 \times 10^{-4} \text{ radian} \\ v_C &= -0.4976019 \times 10^{-4} \text{ inch} \\ u_C &= 0.6814022 \times 10^{-4} \text{ inch} \end{aligned} \right\} (39)$$

These are the actual motions of section C when A is displaced radially through a positive unit distance, and when the motions of B are such as to result in vanishing forces and moments at B. The total motions of B can be obtained by adding up the values corresponding to the following four items:

1. Motions of B when A is displaced radially; given by the solution of equations (26)
2. Motions of B when C is rotated; these are the values listed in equations (29) multiplied by the factor 0.003849891 taken from equations (39)
3. Motions of B when C is displaced radially; these are the values listed in equations (32) multiplied by the factor -0.4976019 taken from equations (39); and
4. Motions of B when C is displaced tangentially; these are the values listed in equations (33) multiplied by the factor 0.6814022 taken from equations (39).

Addition of the individual rotations, radial displacements, and tangential displacements, respectively, yields:

$$\left. \begin{aligned} w_B &= -0.0214944 \times 10^{-4} \text{ radian} \\ v_B &= -0.234245 \times 10^{-4} \text{ inch} \\ u_B &= 0.6881035 \times 10^{-4} \text{ inch} \end{aligned} \right\} (40)$$

It is possible now to determine the radial force at A corresponding to the distorted shape of the ring just calculated. This force depends upon the motions of points A

and B. According to the first entry in the operations table (table 6) the radial force at A caused by a unit radial displacement of A is, provided B is held fixed,

$$R_{AA} = -3.34833 \text{ pounds}$$

If now A is fixed in its displaced position and B is moved into the position indicated by equations (40), the radial force at A caused by these motions can be calculated from the entries in the first column of the operations table (table 6):

$$R_{AB} = -0.0214944 \times 8.92216 + 0.234245 \times 2.69614 \\ + 0.6881035 \times 3.96771 = 3.169978 \text{ pounds}$$

The total radial force at A is the sum of the preceding two forces:

$$R_A = R_{AA} + R_{AB} = -0.178352 \text{ pound} \quad (41)$$

In order to balance out the 500-pound external force carried by one-half of the ring, all the distortions of the ring and force R_A in equation (41) must be multiplied by the factor

$$f = 500/0.178352 = -2803.4448 \quad (42)$$

Multiplication of the values given in equations (40) and (39) yields the final displacements and rotations:

$$\left. \begin{aligned} w_B &= 0.006025836 \text{ radian} & v_B &= 0.065669293 \text{ inch} \\ u_B &= -0.19290602 \text{ inch} & w_C &= -0.001079296 \text{ radian} \\ v_C &= 0.1395000 \text{ inch} & u_C &= -0.191027345 \text{ inch} \end{aligned} \right\} (43)$$

At the same time the radial displacement of point A is naturally

$$v_A = -0.28034448 \text{ inch}$$

With these final values of the displacements and rotations the forces and moments at points A and D can be calculated from the influence coefficients.

These calculations were carried out in the same manner as shown in connection with the solution by relaxations. The results are

$$N_A = 7970.2 \text{ inch-pounds}$$

$$T_A = 13.24 \text{ pounds}$$

$$N_D = 8868 \text{ inch-pounds}$$

$$R_D = -499.8 \text{ pounds}$$

$$T_D = -12.52 \text{ pounds}$$

The accuracy of these results is better than that obtained by relaxations. If N_D is calculated as the sum of N_A and $70 T_A$, the result: namely, 8898 inch-pounds, differs from $N_D = 8868$ inch-pounds by about 0.3 percent. The value of R_D is practically equal to one-half the external load. The sum of T_A and T_D deviates from zero by less than 0.2 percent of one-half the applied load.

Other Solutions of the Problem

As was mentioned in connection with the problem solved in the first section of this paper, namely, the problem of the arc consisting of two quarter circles, the operations table of any problem can be interpreted as a system of simultaneous linear equations. The first two equations obtained from the operations table of the present problem (table 6) are listed below:

$$\left. \begin{aligned} -3.34833 v_A + 8.92216 w_B - 2.69614 v_B + 3.96771 u_B &= 500 \\ 8.92216 v_A - 327.866 w_B + 11.4697 v_B - 13.1014 u_B & \\ - 61.242 w_C + 8.10267 v_C &= 0 \end{aligned} \right\} (44)$$

In the matrix calculus, methods are developed which are helpful in solving large numbers of simultaneous linear equations. In the appendix such methods are explained. The equations representing the egg-shape ring loaded with two equal

and opposite forces were also solved by the matrix calculus. The results obtained are as follows:

$$\left. \begin{aligned} v_A &= -0.280349 \text{ inch} & w_B &= 0.00602607 \text{ radian} \\ v_B &= 0.06567005 \text{ inch} & w_C &= -0.00107944 \text{ radian} \\ v_C &= 0.139503 \text{ inch} & u_C &= -0.191031 \text{ inch} \\ u_B &= +0.192910 \text{ inch} \end{aligned} \right\} (45)$$

It may be seen that these results are practically the same as those given in equations (43). It follows from this agreement of the displacements that the bending moments, the axial forces, and shear forces must also agree. The three most interesting values are given below:

$$\left. \begin{aligned} N_A &= 7970.2 \text{ inch-pounds} \\ T_A &= 12.57 \text{ pounds} \\ N_D &= 8844 \text{ inch-pounds} \end{aligned} \right\} (46)$$

The solutions by relaxation, the procedure of the growing unit, and the matrix calculus were all based on the operations table. An independent check was obtained by solving the problem by the semi-graphic procedure described in reference 7.

In this procedure four imaginary pins were inserted in the ring, and the bending moments at the four pins were considered as the statically indeterminate quantities. The unknowns were combined into suitable symmetric and antisymmetric groups, and their magnitudes were calculated with the aid of the minimum strain energy principle. Details of the calculations are not given here, only the values obtained for N_A , T_A , and N_D are quoted:

$$N_A = 7840 \text{ inch-pounds} \quad T_A = 8.86 \text{ pounds} \quad N_D = 8460 \text{ inch-pounds} \quad (47)$$

The deviation of the value of N_A in equations (47) from that in equations (46) is about 1.6 percent; with N_D the deviation is about 4.3 percent.

The agreement between the results of the graphic and the matrix analysis is astonishingly good taking into consideration that in the graphic analysis extensions and shearing deformations were neglected, while the matrix calculation was based on the operations table which was established with due regard to these types of distortions. For the purpose of gaining further insight into the effects of extensional and shearing deformations, the influence coefficients were recalculated neglecting the effect of these deformations. This amounts to setting $1/Y$ equal to zero in all the equations of reference 5. The operations table calculated with these values of the influence coefficients is table 10.

In this operations table section C is displaced tangentially whenever section B is displaced tangentially, and the two displacements are always equal in magnitude and sense. This is a consequence of the assumption that the ring, in this case the straight portion BC of the ring, does not change its length during the deformations. Because of this rigidity of the straight bar in its own direction, it cannot be determined whether a tangential reaction would be taken up by the constraint at B, or by that at C. Consequently, the tangential force T_{BC} is listed in the operations table, where the double subscript BC indicates that the reaction may be at B or C.

It may be seen that operations table 10 differs greatly from operations table 6. Nevertheless, the matrix solution of the system of linear equations comprising the operations table was found to be very similar to that given earlier in equations (45). The present solution is as follows:

$$\left. \begin{aligned} v_A &= -0.25185 \text{ inch} & w_B &= 0.0058334 \text{ radian} \\ v_B &= 0.062543 \text{ inch} & u_B &= u_C = -0.17491 \text{ inch} \\ w_C &= 0.00091890 \text{ radian} & v_C &= 0.13340 \text{ inch} \end{aligned} \right\} (48)$$

The moments and forces were again calculated as before. Some indicative values are as follows:

$$\left. \begin{aligned} N_A &= 7898.9 \text{ inch-pounds} \\ T_A &= 13.134 \text{ pounds} \\ N_D &= 8819.3 \text{ inch-pounds} \end{aligned} \right\} (49)$$

The difference between corresponding values in equations (49) and (46) is about 0.9 percent in the case of N_A , and about 0.3 percent in the case of N_D . A comparison of all the five solutions of the problem is given below:

	Relaxation	Growing unit	Matrix	Graphic	Second matrix
				(inextensional deformations)	
N_A (in.-lb)	7847	7970.2	7970.2	7840	7898.9
T_A (lb)	17.73	13.24	12.57	8.86	13.134
N_D (in.-lb)	8501	8868	8844	8460	8819.3
R_D (lb)	-483	-499.8	-499.8	-500	-500.0
T_D (lb)	-7.04	-12.52	-12.51	-8.86	-13.152

The moment distribution is shown in figure 9 for the solutions by relaxation, matrices (including the effect of shearing and extensional deformations), and graphic analysis. The curves are very much alike.

FURTHER ILLUSTRATIVE EXAMPLES

The Problem of Distributed Loads

The first example taken up in this chapter deals with the calculation of the bending moment distribution in a circular ring frame of a fuselage the loading of which consists of two equal and opposite forces which add up to a moment in the plane of the ring, and of the balancing shear flow transmitted to the ring from the sheet covering of the fuselage. (See fig. 10.) It is customary to assume that the shear flow can be calculated from the formula $q = T/2A$, where q is the shear flow in pounds per inch, T the torque in inch-pounds, and A the area of the circle in square inches. Recent investigations by Wignot, Combs, and Ensrud (reference 10), and by Hoff (reference 11) showed that in sections of the fuselage adjacent to rings loaded with concentrated forces the shear flow differs considerably from that predicted by classical theory, unless the ring has an unusually large bending rigidity. Because of its basic assumptions the classical theory holds only at a distance from the load application which is of the order of magnitude of the diameter of the fuselage.

It is not the purpose of the present report to investigate the shear flow in the thin wall of a monocoque fuselage. The report deals only with the calculation of the bending moments in rings the loading of which is specified. It will be assumed, therefore, that the shear flow in the present example is constant and has the value predicted by classical theory.

The procedures developed in the preceding chapters can be easily extended to include the effects of distributed loads. The basic idea in these procedures was to break up the ring into a number of units, and to clamp rigidly the end points of the units. The clamps were then removed partially at the different points in turn permitting a change in the value of one displacement coordinate at a time. When one or more of the units are loaded with distributed loads, as in the present case with the constant shear flow, the units can be considered as curved beams the ends of which are rigidly clamped to the constraints. The statically indeterminate reactions (including reaction moments) at the constraints can be calculated with the aid of the classical beam theory. Forces and moments equal in magnitude and opposed in sense to these reactions are the loads transmitted to the constraints because of the distributed loads of the curved beams. These forces at the constraints do not differ in any respect from the concentrated external loads of the rings discussed in the preceding chapters. They can be taken into account, therefore, in the manner shown before by relaxation, the growing unit procedure, or by solution by matrices. The graphic method of reference 7 takes care of distributed loads directly.

The problem at hand reduces, therefore, to the calculation of the statically indeterminate reactions of curved beams. In reference 5 the calculations were carried out for beams having arcs of a circle for their median line the loading of which consisted of a uniform shear flow. It is believed that any ring can be represented by arcs of a circle with an accuracy sufficient for engineering applications. Similarly, any variable shear flow over an arc may be replaced by a number of constant shear flows acting upon portions of the arc.

Torsion of a Circular Ring

Basic data.— Figure 10 shows the circular ring of a fuselage and its loading. The latter consists of two 100-pound vertical loads of opposite sense, and the balancing shear flow

transmitted to the ring from the sheet covering. The intensity of the shear flow is

$$q = T/2A = (100 \times 20 \times \sqrt{2}) / (2\pi \times 20^2) = 1.1253954 \text{ pounds per inch} \quad (50)$$

The cross-sectional area and the moment of inertia of the section shown in figure 10 are

$$A = 0.250 \text{ square inch} \quad I = 0.1666 \text{ inch}^4$$

The latter is taken about the horizontal centroidal axis. The ratio ξ of the effective shear area to the total cross-sectional area of the section was calculated from equation (11) of reference 5:

$$\xi = 0.160$$

Because of the antisymmetry only one-half of the ring need be considered. The half ring is subdivided in two units, one extending from point A on the axis of symmetry to the external load (point B), the other from the load to point C on the axis of symmetry of the ring. The angles subtended by the arcs are 45° and 135° , respectively. The parameter

$$Y = AL^2/I$$

has the values 370.258 and 3332.32, respectively, for arcs AB and BC. With

$$45^\circ = 0.785398175 \text{ radian} \quad \text{and} \quad 135^\circ = 2.3561945 \text{ radians}$$

κ and λ are calculated as in the preceding chapter:

$$\kappa = 1.0120785 \quad \lambda = 0.9912535$$

These values are valid for both arcs.

Influence coefficients. The influence coefficients were calculated with the aid of reference 5 in the same manner as was done for the egg-shape ring of the preceding chapter. Since the cross section of the ring is constant, EI is a constant factor in every influence coefficient. It is convenient to assume its value as 10^6 pound-inches²

rather than to use the actual value. If the unit displacement is taken as 10^{-3} inch and the unit rotation as 10^{-3} radian, the influence coefficients of arc AB become:

$$\left. \begin{aligned} \widehat{nn}_M &= 281.950 & \widehat{nr}_M &= -42.385 & \widehat{nt}_M &= 49.079 \\ \widehat{rr}_M &= 11.178 & \widehat{rt}_M &= -20.559 & \widehat{tt}_M &= 52.296 \\ \widehat{nn}_F &= -29.966 & \widehat{nr}_F &= -4.733 & \widehat{nt}_F &= 64.675 \\ \widehat{rr}_F &= 6.633 & \widehat{rt}_F &= -22.441 & \widehat{tt}_F &= 51.516 \end{aligned} \right\} (51)$$

The influence coefficients of arc BC are:

$$\left. \begin{aligned} \widehat{nn}_M &= 157.899 & \widehat{nr}_M &= -10.942 & \widehat{nt}_M &= 1.563 \\ \widehat{rr}_M &= 1.160 & \widehat{rt}_M &= -0.419 & \widehat{tt}_M &= 0.322 \\ \widehat{nn}_F &= 56.5117 & \widehat{nr}_F &= -8.842 & \widehat{nt}_F &= 6.632 \\ \widehat{rr}_F &= 1.116 & \widehat{rt}_F &= -0.524 & \widehat{tt}_F &= 0.0685 \end{aligned} \right\} (52)$$

Operations Table

The operations table can be established now according to the principles discussed earlier. Because of the antisymmetry points A and C cannot move vertically. (See reference 9.) Consequently, v_A and v_C are not listed in the operations table (table 11). Moreover, there is no need for balancing out R_A and R_C in the relaxations since whatever values are obtained for them during the relaxations of the right-hand side of the ring, values of the same magnitude and opposite sense would be caused by the antisymmetric distortions of the left-hand side of the ring. It was also found convenient to move point C as well as A during the relaxations. This is a deviation from the procedure followed in the relaxation of the egg-shape ring.

Effect of the shear flow. - The next step in the calculations is the determination of the effect of the distributed shear. The reactions of the shear flow at the constraints, acting upon the curved beams and taken according to the beam convention of signs shown in figure 6a, can be calculated from equations (33) of reference 5. For arc AB the values of the determinants are:

$$\left. \begin{aligned}
 \Delta_q &= 0.14486386 r^2 = 2.8932727 \\
 -\Delta_{n_q} &= 0.0005897221 qr^3 = 5.3093649 \\
 \Delta_{r_q} &= 0.008936527 qr^2 = 4.0228506 \\
 -\Delta_{t_q} &= 0.05622000 qr^2 = 25.3078929
 \end{aligned} \right\} (53)$$

Division of the numerator determinants by the denominator determinant gives the moment, the radial force, and the tangential force acting upon the beam at the support toward which the shear flow is directed:

$$\left. \begin{aligned}
 n_q &= -1.8350724 \text{ inch-pounds} \\
 r_q &= 1.3904153 \text{ pounds} \\
 t_q &= -8.7471509 \text{ pounds}
 \end{aligned} \right\} (54)$$

The corresponding values for arc BC are:

$$\left. \begin{aligned}
 \Delta_q &= 1.26215684 r = 25.2431368 \\
 -\Delta_{h_q} &= 0.1489809 qr^3 = 1341.3002 \\
 \Delta_{r_q} &= 0.7079546 qr^2 = 318.69158 \\
 -\Delta_{t_q} &= 1.3379626 qr^2 = 602.29481
 \end{aligned} \right\} (55)$$

$$\left. \begin{aligned}
 n_q &= -53.135241 \text{ inch-pounds} \\
 r_q &= 12.624880 \text{ pounds} \\
 t_q &= -23.859745 \text{ pounds}
 \end{aligned} \right\} (56)$$

As mentioned before, these forces and moments represent the reactions upon the beams. The forces and the moment acting upon the constraint at section A have the values given in equations (54) multiplied by -1. If the signs are now converted to agree with the rigid frame convention of figure 6b, the final values become:

$$\left. \begin{aligned} N_A &= -1.8350724 \text{ inch-pounds} \\ R_A &= -1.3904153 \text{ pounds} \\ T_A &= -8.7471509 \text{ pounds} \end{aligned} \right\} (57)$$

In section B the reactions upon beam AB can be obtained by multiplying by -1 the values given by equations (54) since the shear flow is directed away from point B. The signs of the reactions so calculated are in accordance with the beam convention. The different steps needed for obtaining the effect of beams AB and BC upon the constraint at B are summarized below:

	N_B (in.-lb)	R_B (lb)	T_B (lb)
Reactions upon AB, beam convention, shear flow away from B (from equations (54))	1.8350724	-1.3904153	8.7471509
Action of beam AB upon constraint, beam convention	-1.8350724	1.3904153	-8.7471509
Action of beam AB upon constraint, rigid frame convention	-1.8350724	1.3904153	-8.7471509
Reactions upon BC, beam convention, shear flow toward B (from equations (56))	-53.135241	12.624880	-23.859745
Action of beam BC upon constraint, beam convention	53.135241	-12.624880	23.859745
Action of beam BC upon constraint, rigid frame convention	-53.135241	-12.624880	-23.8597450
Total unbalances due to shear flow	-54.970313	-11.2344647	-32.6068959

The 100-pound vertical downward external load at B also contributes to the tangential and radial unbalanced forces. If this is resolved in the radial and tangential directions, the result is

$$R_B = 70.710678 \text{ pounds} \qquad T_B = 70.710678 \text{ pounds}$$

Hence the total unbalances are:

$$\left. \begin{aligned} N_B &= -54.970313 \text{ inch-pounds} \\ R_B &= 59.4762133 \text{ pounds} \\ T_B &= 38.1037821 \text{ pounds} \end{aligned} \right\} (58)$$

In section C the reactions are the values given by equations (56) multiplied by -1 since the shear flow is directed away from point C. The action upon the constraint is obtained by one more multiplication by -1. The change from the beam convention to the rigid frame convention does not entail any changes in these values. Hence the final values of the unbalances are:

$$\left. \begin{aligned} N_C &= -53.135241 \text{ inch-pounds} \\ R_C &= 12.624880 \text{ pounds} \\ T_C &= -23.859745 \text{ pounds} \end{aligned} \right\} (59)$$

Solution by relaxations.— The relaxation was carried out in table 12. It may be noticed that it was more advantageous to carry out operations on the longer, than on the shorter arc. Moreover, sequences of the rotations w_C, w_B, w_A were found useful.

From the total motions of A and B the radial force at A can be calculated. The motions are, as computed from table 12:

$$\begin{aligned} w_A &= 1.15 \times 10^{-3} \text{ radian} \\ u_A &= -4.87 \times 10^{-3} \text{ inch} \\ w_B &= -2.96 \times 10^{-3} \text{ radian} \\ v_B &= u_B = 0 \end{aligned}$$

These notions must be multiplied by the respective influence coefficients as given in equations (51). It should be remembered, however, that in the calculation of the influence coefficients the beam convention was used, so that the foregoing motions must be transformed to conform with the beam convention. Reference to figure 6 discloses that the signs of w_A and u_A must be changed, while the sign of w_B remains unchanged. Consequently,

$$\begin{aligned} w_A &= -1.15 \times 10^{-3} \text{ radian} & u_A &= +4.87 \times 10^{-3} \text{ inch} \\ w_B &= -2.96 \times 10^{-3} \text{ radian} & v_B = u_B &= 0 \end{aligned}$$

With these values the radial force becomes

$$R_A = 1.15 \times 42.385 - 4.87 \times 20.559 + 2.96 \times 4.733 = -37.3699$$

pounds

This force, caused by the distortions, has to be added to the radial force caused by the shear flow and given in equations (54). Altogether,

$$R_A = -37.3699 + 1.3904153 = -35.979 \text{ pound}$$

Since the tangential force and the moment at A have the value zero, the bending moment distribution along the ring can be calculated with the aid of the elementary methods of statics. The moments are caused by R_A and the shear flow along arc AB, and by R_A , the external load, and the shear flow along arc BC. The actual calculation is not shown here. It will be taken up in connection with the analytical solution of the problem. The bending moment distribution is shown in figure 12.

Solution by the growing unit procedure.— The problem was also worked out by the growing unit method. In these calculations point C was considered as rigidly fixed. This fixation means only that the three possible rigid body displacements of the ring in its plane were eliminated. The changes in the shape of the ring caused by the loading were in no way restricted by the assumption.

As a first step, section A was rotated through an angle of 10^{-3} radian. The effect of this rotation upon B is the

appearance of the unbalances listed in the third to fifth columns of the operations table (table 11).

Next, section B was displaced and rotated, while sections A and C were held fixed, in such a manner as to balance out the unbalanced forces and moment at B. The necessary motions of B were calculated from the following three simultaneous linear equations:

$$\left. \begin{aligned} -439.849 w_B + 31.443 v_B - 50.642 u_B &= 29.966 \\ 31.443 w_B - 12.338 v_B + 20.14 u_B &= 4.733 \\ -50.642 w_B + 20.14 v_B - 52.618 u_B &= -64.675 \end{aligned} \right\} (60)$$

The solution of these equations is

$$\left. \begin{aligned} w_B &= -0.11135692 \times 10^{-3} \text{ radian} \\ v_B &= 4.035013 \times 10^{-3} \text{ inch} \\ u_B &= 2.880754 \times 10^{-3} \text{ inch} \end{aligned} \right\} (61)$$

The effect of these motions upon A can be computed from the operations table:

$$\begin{aligned} N_A &= 29.966 \times 0.11135692 - 4.733 \times 4.035013 + 64.675 \times 2.880754 \\ &= 170.552 \text{ inch-pounds} \end{aligned}$$

$$\begin{aligned} T_A &= -64.675 \times 0.11135692 - 22.441 \times 4.035013 + 51.516 \times 2.880754 \\ &= 50.653185 \text{ pounds} \end{aligned}$$

The effect of the unit rotation of A upon A (when B is fixed) is listed in the operations table:

$$N_A = -281.95 \text{ inch-pounds} \quad T_A = -49.079 \text{ pounds}$$

Altogether,

$$\left. \begin{aligned} N_A &= -281.95 + 170.552 = -111.398 \text{ inch-pounds} \\ T_A &= 50.653185 - 49.079 = 1.574185 \text{ pounds} \end{aligned} \right\} (62)$$

These are the moment and the tangential force obtained at A when A is rotated through a unit angle; and B moves in such a manner as to cause vanishing unbalances at B. In other words, N_A and T_A of equation (62) are influence coefficients of the expanded unit arc AC.

The influence coefficients of arc AC corresponding to a tangential displacement of A can be obtained in a similar manner. When section A is displaced tangentially through a distance of 10^{-3} inch, the unbalances at B are the items listed in the third, fourth, and fifth columns of the second row of the operations table. These unbalances vanish if the motions of B satisfy the following equations:

$$\left. \begin{aligned} -439.849 w_B + 31.443 v_B - 50.642 u_B &= -64.675 \\ 31.443 w_B - 12.338 v_B + 20.14 u_B &= 22.441 \\ -50.642 w_B + 20.14 v_B - 52.618 u_B &= -51.516 \end{aligned} \right\} \text{---(63)---}$$

The solution is

$$\left. \begin{aligned} w_B &= 0.022242916 \times 10^{-3} \text{ radian} \\ v_B &= -0.53023016 \times 10^{-3} \text{ inch} \\ u_B &= 0.7546986 \times 10^{-3} \text{ inch} \end{aligned} \right\} \text{---(64)---}$$

The effect of these motions upon A can be computed from the operations table:

$$N_A = -29.966 \times 0.022242916 + 4.733 \times 0.53023016 + 64.675 \times 0.7546986$$

$$= 50.653185 \text{ inch-pounds}$$

$$T_A = 64.675 \times 0.022242916 + 22.441 \times 0.53023016 + 51.516 \times 0.7546986$$

$$= 52.216509 \text{ pounds}$$

The effect of the unit tangential displacement of A upon itself is again taken directly from the operations table.

$$N_A = -49.079 \text{ inch-pounds} \quad T_A = -52.296 \text{ pounds}$$

Altogether,

$$\left. \begin{aligned} N_A &= 50.653188 - 49.079 = 1.574188 \text{ inch-pounds} \\ T_A &= 52.216509 - 52.296 = -0.079491 \text{ pound} \end{aligned} \right\} (65)$$

These are the influence coefficients of arc AC sought.

In the next step, the external loads acting upon B are balanced out by moving section B. The necessary motions can be calculated from three linear equations the left-hand members of which are identical with those of equations (60) and (62). The right-hand members are the unbalances of equations (58):

$$54.970313$$

$$-59.47621$$

$$-38.103782$$

The solution is

$$\left. \begin{aligned} w_B &= 0.2815947 \times 10^{-3} \text{ radian} \\ v_B &= 16.7320519 \times 10^{-3} \text{ inch} \\ u_B &= 6.8574788 \times 10^{-3} \text{ inch} \end{aligned} \right\} (66)$$

The effect of these displacements upon A is:

$$\begin{aligned} N_A &= -29.966 \times 0.2815947 - 4.733 \times 16.7320519 + 64.675 \times 6.8574788 \\ &= -355.8764 \text{ inch-pounds} \end{aligned}$$

$$\begin{aligned} T_A &= 64.675 \times 0.2815947 - 22.441 \times 16.7320519 + 51.516 \times 6.8574788 \\ &= -4.001964 \text{ pounds} \end{aligned}$$

These are the unbalances caused at A by balancing out the unbalances at B. To these must be added the unbalances caused at A by the shear flow as given by equations (57). Altogether, the unbalances at A are:

$$\left. \begin{aligned} N_A &= 355.8764 - 1.8350724 = 354.04133 \text{ inch-pounds} \\ T_A &= -4.001964 - 8.7471509 = -12.749114 \text{ pounds} \end{aligned} \right\} (67)$$

The unbalances quoted in equations (67) must then be balanced out by moving A which is now considered as the end point of the expanded unit, AO. The requirement of vanishing unbalances at A can be written with the aid of the influence coefficients of equations (62) and (65) as

$$\left. \begin{aligned} -111.398 w_A + 1.574185 u_A &= -354.04133 \\ 1.574185 w_A - 0.079491 u_A &= 12.749114 \end{aligned} \right\} (68)$$

The solution of these equations is

$$\left. \begin{aligned} w_A &= 1.2660489 \times 10^{-3} \text{ radian} \\ u_A &= -135.31193 \times 10^{-3} \text{ inch} \end{aligned} \right\} (69)$$

The values contained in equations (69) completely define the deflected shape of the ring. Equations (61) and (64) contain the data necessary for the calculation of the motions of B due to the displacements of A:

$$w_B = -1.2660489 \times 0.11135692 - 135.31193 \times 0.022242916 = -3.1507157$$

$$v_B = 1.2660489 \times 4.035013 + 135.31193 \times 0.53023016 = 76.8560744$$

$$u_B = 1.2660489 \times 2.880754 - 135.31193 \times 0.7546986 = -98.4724888$$

To these motions those undertaken when B was balanced must be added. The latter are stated in equations (66). Altogether,

$$\left. \begin{aligned} w_B &= -3.1507157 + 0.2816947 = -2.869121 \times 10^{-3} \text{ radian} \\ v_B &= 76.8560744 + 16.7320519 = 93.5881263 \times 10^{-3} \text{ inch} \\ u_B &= -98.4724888 + 6.8574788 = -91.615010 \times 10^{-3} \text{ inch} \end{aligned} \right\} (70)$$

Equations (69) and (70) represent the complete specification of the distorted shape of the ring since section C was considered as rigidly fixed. The value of R_A can now be calculated easily with the aid of the influence coefficients listed in equations (51). It must be remembered, however, that the influence coefficients are always calculated in accordance with the beam convention. In this convention the motions of end section B of beam AB have the same signs as in the rigid frame convention. The motions at A, however, must be transformed to read:

$$\left. \begin{aligned} w_A &= -1.2660489 \times 10^{-3} \text{ radian} \\ u_A &= 135.31193 \times 10^{-3} \text{ inch} \end{aligned} \right\} \quad (71)$$

Hence,

$$\begin{aligned} R_A &= 42.385 \times 1.2660489 - 20.559 \times 135.31193 + 4.733 \times 2.869121 \\ &+ 6.633 \times 93.5881246 + 22.441 \times 91.61501 = -37.93446 \text{ pounds} \end{aligned}$$

It must be remembered that an unbalanced radial force of -1.3904153 pound was applied at A because of the distributed shear, as stated in equations (54). If this is added to the value calculated above for R_A , the following final shear force in section A is obtained:

$$R_A = -36.544045 \text{ pounds} \quad (72)$$

Knowledge of the shear force in section A permits the calculation of the bending moments in the ring. The calculations are not shown here. They are discussed in connection with the analytic solution of the problem.

The forces and the moment in section C are now determined since they can serve as a check of the accuracy of the calculations. If the influence coefficients given in equations (52) are used, the motions of section B as stated in equations (70) must be transformed to conform with the beam convention:

$$w_B = 2.869121 \times 10^{-3} \text{ radian}$$

$$v_B = 93.5881246 \times 10^{-3} \text{ inch}$$

$$u_B = 91.615010 \times 10^{-3} \text{ inch}$$

Then,

$$N_C = 56.5117 \times 2.869121 - 8.842 \times 93.5881246 + 6.632 \times 91.615010 \\ = -57.77655 \text{ inch-pounds}$$

$$R_C = -8.842 \times 2.869121 + 1.116 \times 93.5881246 - 0.524 \times 91.615010 \\ = 31.069316 \text{ pounds}$$

$$T_C = 6.632 \times 2.869121 - 0.524 \times 93.5881246 + 0.0685 \times 91.615010 \\ = -23.736486 \text{ pounds}$$

To these values must be added the forces and the moment caused at C by the shear flow in bar BC. Equations (56) contain these quantities. The signs, however, must be changed since the shear flow is directed away from section C. Addition gives

$$\left. \begin{aligned} N_C &= -57.77655 + 53.135241 = -4.641309 \text{ inch-pounds} \\ R_C &= 31.069316 - 12.624880 = 18.44444 \text{ pounds} \\ T_C &= -23.736486 + 23.859745 = 0.123259 \text{ pound} \end{aligned} \right\} (73)$$

The terms N_C and T_C should be zero because of the anti-symmetry. Since the maximum bending moment in the ring is -482 inch-pound, the deviation from zero is only about 1 percent of the maximum. The deviation of T_C from zero is about 0.1 percent of the applied load of 100 pounds. The check of R_C can be made as follows: $R_A - R_C$ is -54.98849 pound. This quantity represents the total shear transmitted through the plane of symmetry of the ring. The shear is acting upward because of the negative sign. The vertical component of the shear flow acting upon the right-hand side of the ring is $1.1253954 \times 40 = 45.015816$ pounds. This is also directed upward. Altogether, the upward force upon one-half the ring is

$$54.98849 + 45.015816 = 100.004306 \text{ pounds}$$

It should be equal to the 100-pound downward external force.

Matrix solution.— The problem was also solved by the method of matrix transformations as shown in the appendix. The motions obtained are listed below:

$$\left. \begin{aligned} w_A &= 1.2646 \times 10^{-3} \text{ radian} \\ u_A &= -135.3985 \times 10^{-3} \text{ inch} \\ w_B &= -2.8709 \times 10^{-3} \text{ radian} \\ v_B &= 93.6280 \times 10^{-3} \text{ inch} \\ u_B &= -91.6842 \times 10^{-3} \text{ inch} \end{aligned} \right\} (74)$$

Section C was again held fixed.

The displacements according to equations (74) are in good agreement with those found by the growing unit procedure and listed in equations (69) and (70).

Analytic solution.— In the analytic solution again the lowermost point of the ring is considered fixed. (See fig. 11.) In the section at the topmost point the unknown tensile force T , shear force V , and moment N must be applied. Because of the antisymmetry, however, $N = T = 0$. Hence the bending moment is caused only by V , the external concentrated load of 100 pounds, and the shear flow. The contribution of the latter can be calculated with the aid of figure 11b.

The shear force acting upon the infinitesimal element of arc subtended by the angle $d\xi$ is $qr d\xi$. The moment dM caused by this shear force at φ is

$$dM = q r d\xi = r [1 - \cos(\varphi - \xi)] q r d\xi$$

The moment M_φ caused at φ by all the shear flow from $\xi = 0$ to $\xi = \varphi$ is consequently

$$M_\varphi = \int_0^\varphi q r^2 [1 - \cos(\varphi - \xi)] d\xi = q r^2 (\varphi - \sin \varphi) \quad (75)$$

The total moment is

$$M_1 = qr^2(\varphi - \sin \varphi) + Vr \sin \varphi$$

when $0 \leq \varphi \leq 45^\circ$

$$M_2 = qr^2(\varphi - \sin \varphi) + Vr \sin \varphi + 100 r(\sin \varphi - 0.707) \quad (76)$$

when $45^\circ \leq \varphi \leq 180^\circ$

The strain energy of bending is

$$U = \frac{1}{2EI} \int_0^{45^\circ} M_1^2 r d\varphi + \frac{1}{2EI} \int_{45^\circ}^{180^\circ} M_2^2 r d\varphi$$

According to Castigliano's principle

$$dU/dV = 0$$

The differentiation may be carried out before the integration:

$$\frac{dU}{dV} = \frac{r}{EI} \int_0^{45^\circ} M_1 \frac{dM_1}{dV} d\varphi + \frac{r}{EI} \int_{45^\circ}^{180^\circ} M_2 \frac{dM_2}{dV} d\varphi = 0$$

If the operations indicated are carried out, the following equation is obtained:

$$qr + V + (200/\pi)[(3\pi/8) - (1/4) - 0.707] = 0$$

Since

$$q = (100 \times 2r \times 0.707)/(2\pi r^2)$$

the shear force becomes

$$V = -36.5766 \quad (77)$$

It may be seen that this value agrees well with those obtained for R_A in the earlier solutions. Substitution of q , r , and V in equations (76) leads to the final expressions for the bending moments:

$$M_1 = 450.16 (\varphi - \sin \varphi) - 731.53 \sin \varphi = 450.16 \varphi - 1181.69 \sin \varphi \quad (78)$$

when $0 \leq \varphi \leq 45^\circ$

$$M_2 = 450.16 (\varphi - \sin \varphi) - 731.53 \sin \varphi + 2000 (\sin \varphi - 0.707) = -1414 + 450.16 \varphi + 818.31 \sin \varphi \quad (79)$$

when $45^\circ \leq \varphi \leq 180^\circ$

The bending moment diagram is shown in figure 12.

Torsion of the Braced Circular Ring

In actual airplane fuselages the rings are often internally braced when large concentrated loads are introduced into them. Such a braced circular ring is shown in figure 13. Since the addition of the brace causes six more statically indeterminate quantities to appear in the calculations, the work involved in the analytic solution of the problem of the bending moment distribution becomes very much more involved than it was in the case discussed in the preceding article. Because of the antisymmetry the actual work involves only the determination of one unknown quantity in the ring proper and three unknowns caused by the braces. The increase in the work is then as follows:

Calculation of 5 moment diagrams instead of 2

Calculation of 14 definite integrals instead of 2

Solution of 4 simultaneous equations for 4 unknowns, instead of getting 1 unknown from 1 equation

In the methods proposed in this report, the additional work consists only of the calculation of the influence coefficients of the braces. Because of the effect of the braces

the numerical values in the operations table will be different, but the number of entries in the operations table will remain the same. The solution of the problem by relaxation or by the growing unit procedure will, therefore, not involve any more work than in the case of the ring without the brace.

The length of the diagonal is $L = 36.955182$ inches. Its cross-sectional area is $A = 0.125$ square inch, and its maximum moment of inertia $I = 0.020833$ inch⁴. Since in the calculation of the influence coefficients of the ring in equations (51), EI was assumed to be 10^6 pound-inches² while I was 0.1666 inch⁴, the calculations will be consistent only if the EI of the brace is assumed

$$EI = (0.020833/0.1666)10^6 = 125,000 \text{ pound-inches}^2$$

This means, of course, that the deflections to be calculated would be the actual ones if the material had a modulus of $E = 6 \times 10^6$ psi. With aluminum alloys, or steel, the values must be multiplied by a constant factor.

The ratio $I_3 = I_3^*/A$ is again 0.16 . Consequently, $\gamma = 8194.1131$ and the product $\gamma I_3 = 1311.0581$. The influence coefficients for the movable end of the straight bar were calculated from equations (25) of reference 5:

$$\left. \begin{aligned} \overline{nn}_M &= 13.4379 & \overline{nr}_M &= 0.544194 & \overline{nt}_M &= 0 \\ \overline{rr}_M &= 0.0294516 & \overline{rt}_M &= 0 & \overline{tt}_M &= 20.2949 \end{aligned} \right\} (80)$$

The influence coefficients for the fixed end were determined with the aid of equations (33) of reference 5:

$$\left. \begin{aligned} \overline{nn}_F &= -6.67292 & \overline{nr}_F &= 0.544194 & \overline{nt}_F &= 0 \\ \overline{rr}_F &= -0.0294516 & \overline{rt}_F &= 0 & \overline{tt}_F &= 20.2949 \end{aligned} \right\} (81)$$

Since in the operations table points B and C are moved tangentially and radially to the circle, it is necessary to convert the above influence coefficients into values that correspond to those displacements. For instance, a unit displacement at B tangentially to the circle downward

to the right is equivalent to a tangential (longitudinal) displacement of $-\sin 22.5^\circ$ for the straight bar combined with a radial (perpendicular) displacement of $\cos 22.5^\circ$ for the straight bar, when the beam convention of figure 14b is used. With

$$\sin 22.5^\circ = 0.38268 \quad \cos 22.5^\circ = 0.92388$$

the following forces and moment are obtained at B, acting upon the straight bar and designated according to the beam convention:

$$N_{SB} = -0.544194 \times 0.92388 = -0.50277 \text{ inch-pound}$$

$$R_{SB} = 0.0294516 \times 0.92388 = 0.02721 \text{ pound}$$

$$T_{SB} = -20.2949 \times 0.38268 = -7.76845 \text{ pounds}$$

where the subscript SB designates that the forces and the moment are based upon the system of coordinates of the straight bar. They must be converted to conform with the system of coordinates based on the circle before they can be entered in the operations table. If the subscript CB refers to the system of coordinates of the circle, and use is made of the diagrams of figures 14c and 14d, the following values are obtained:

$$N_{CB} = N_{SB} = -0.50277 \text{ inch-pound}$$

$$\begin{aligned} R_{CB} &= -R_{SB} \sin 22.5^\circ - T_{SB} \cos 22.5^\circ \\ &= -(0.02721) \times 0.38268 + (7.76845) \times 0.92388 = 7.1667 \text{ pounds} \end{aligned}$$

$$\begin{aligned} T_{CB} &= R_{SB} \cos 22.5^\circ - T_{SB} \sin 22.5^\circ \\ &= (0.02721) \times 0.92388 + (7.76845) \times 0.38268 = 2.9980 \text{ pounds} \end{aligned}$$

The forces and the moment just calculated represent the action upon the structure. Multiplication by -1 converts them into the effect of the structure upon the constraints, taken in accordance with the rigid frame convention based on the circle. These values must be added to those listed in the operations table of the circular frame without bracing (table 11). The sums have been entered in the new operations table (table 13).

The effect of a radial displacement and of a rotation can be found in a similar manner. As a further example for the resolutions, the effect upon C (the fixed end) of a unit rotation of B (the movable end) is now considered.

A unit clockwise rotation of section B of the circle is the positive unit rotation of section B of the straight bar as shown in figure 14b. The forces and the moment caused at C by this rotation are given in equation (81):

$$N_{SB} = -6.67292 \text{ inch-pounds}$$

$$R_{SB} = 0.544194 \text{ pound}$$

$$T_{SB} = 0$$

These quantities are the forces and moments acting upon the straight bar at C and taken according to the beam convention shown in figure 15b. A positive moment N_{SB} at C is counterclockwise. Hence, the moment N_{CB} taken in accordance with the rigid frame convention of the circle has the opposite sign:

$$N_{CB} = -N_{SB} = 6.67292 \text{ inch-pounds}$$

The radial force R_{SB} is resolved with the aid of figure 15c:

$$R_{CB} = -R_{SB} \sin 22.5^\circ = -0.544194 \times 0.38268 = -0.20825 \text{ pound}$$

$$T_{CB} = -R_{SB} \cos 22.5^\circ = -0.544194 \times 0.92388 = -0.50277 \text{ pound}$$

The values of N_{CB} , R_{CB} , and T_{CB} must be multiplied by -1 in order to obtain the effect of the structure upon the constraints as required for the operations table.

The operations table for the braced circular ring is presented as table 13. It was used in the relaxations contained in table 14. As may be seen, the relaxations were carried out in the same manner as in the case of the ring without bracing. The absolute magnitudes of the deflections were found to be much smaller than before. For the shear force at A the value -6.4964 pounds was obtained.

The distortions were determined also by the growing unit procedure. The individual steps in the calculation are not given here since, except for the numerical values, they were identical with those presented in the preceding article. Section C was again assumed to be fixed. The distortions were found to be:

$$\left. \begin{aligned} w_A &= 0.57486859 \times 10^{-3} \text{ radian} \\ u_A &= 6.499450 \times 10^{-3} \text{ inch} \\ w_B &= -0.04252815 \times 10^{-3} \text{ radian} \\ u_B &= 0.21585307 \times 10^{-3} \text{ inch} \\ u_{B'} &= 7.4627458 \times 10^{-3} \text{ inch} \end{aligned} \right\} (82)$$

Comparison of the values given in equations (82) with those contained in equations (69) and (70) reveals the great stiffening effect of the braces.

The value of the shear force in section A was found to be -6.460 pounds. This value deviates from that obtained by relaxations by 0.6 percent. The bending moment diagram is shown in figure 16. It may be seen that the introduction of the braces resulted in the reduction of the maximum bending moment from -482 inch-pounds to -259.1 inch-pounds.

The problem was also solved by the method of matrices. The resulting distortions differed only insignificantly from those listed in equations (82).

Torsion of the Egg-Shape Ring

The egg-shape ring and its antisymmetric loading shown in figure 17 are the same as those presented in reference 7. The shape of the structure is identical with that used earlier in this report when the bending moments caused by two equal and opposite forces were calculated. As in the case of the twisted circular ring, it is assumed that the shear flow transmitted from the sheet covering of the fuselage to the ring is constant and can be calculated from the formula

$$q = T/2A$$

In the present case the torque

$$T = 100 \times 30 = 3000 \text{ inch-pounds}$$

while the area included by the ring

$$A = 2757.642 \text{ square inches}$$

Hence,

$$q = 3000 / (2 \times 2757.642) = 0.54394298 \text{ pound per inch}$$

When the operations table was set up, the shearing and extensional strain energies were neglected. This is equivalent to setting $1/\gamma = 0$, as was explained when the loading consisted of two equal and opposite forces. The angles subtended by the units considered are;

$$\text{Arc AB} \quad 0.84806211 \text{ radian}$$

$$\text{Arc BC} \quad 0.52137719 \text{ radian}$$

$$\text{Arc DE} \quad 1.7721543 \text{ radians}$$

The influence coefficients were calculated and the operations table was established according to the procedure discussed in the earlier parts of this report. The operations table is reproduced as table 15. It served as the basis for the calculation of the distortions by the growing unit method. The distributed shear forces were taken into account as explained in connection with the torsion of the circular ring. Point H was considered as rigidly fixed. Because of the antisymmetry, section A could not move radially.

Solution by the growing unit method. - The application of the growing unit procedure to this particular problem consisted of three main parts. In the first, the expanded units were established; in the second, the unbalances were transmitted from sections B, C, and D to sections A and E; and in the last part, the unbalances at A were eliminated.

The bending moment diagram was calculated and is presented in figure 18. The dotted line represents the bending moments obtained in reference 7 by the graphic method. The agreement is reasonably good.

Torsion of the Braced Egg-Shape Ring

Figure 19 shows the braced egg-shape ring and its anti-symmetric loading. The cross section of the brace was taken the same as in the case of the braced circular ring. The length of the diagonal is 64.983655 inches. The influence coefficients were calculated and the operations table was established according to the principles discussed earlier.

The data contained in the operations table (table 16) served as a basis for the calculation of the deflections by the growing unit procedure. The results are:

$$\begin{aligned}
 w_A &= -0.7703992 \times 10^{-3} \text{ radian} & w_C &= 0.19370249 \times 10^{-3} \text{ radian} \\
 u_A &= -12.059222 \times 10^{-3} \text{ inch} & v_C &= 9.243786 \times 10^{-3} \text{ inch} \\
 w_B &= -0.00896880 \times 10^{-3} \text{ radian} & u_{CD} &= -9.301079 \times 10^{-3} \text{ inch} \\
 v_B &= 1.9469763 \times 10^{-3} \text{ inch} & w_D &= -0.1969324 \times 10^{-3} \text{ radian} \\
 u_B &= -12.20075 \times 10^{-3} \text{ inch} & v_D &= 10.421443 \times 10^{-3} \text{ inch}
 \end{aligned}$$

The motions of sections A and B in conjunction with the influence coefficients permit the calculation of the shearing force R_A in section A:

$$R_A = 6.3015 \text{ pounds}$$

The motions of B and the influence coefficients of the straight bar BE suffice for the calculation of the forces and moments acting on bar BE. When these are known, the bending moment diagram of the ring can be determined.

The bending moment diagram is presented in figure 20. It may be seen that the bracing was very beneficial in reducing the bending moments.

CONCLUSIONS

The subject of this report is the numerical calculation of the distortions of and the bending moments in rigid frames (fuselage rings) of arbitrary shape upon which known concentrated and distributed loads are acting. The calculations

consist of two major parts: the setting-up of the equations characterizing the problem, and their solution.

The equations are set up by dividing the frame into a number of beams, each having a constant radius of curvature and a constant (often zero) distributed load. The influence coefficients of the individual beams can be easily computed with the aid of the formulas, tables, and graphs presented in reference 5. They can be combined into quantities that are entered in the operations table according to the suggestions made in this report. The operations table, together with the external loads, completely defines the problem, and can always be established without difficulty.

On the other hand, difficulties are encountered in the solution of the set of linear equations defined by the operations table. The fundamental reason for the difficulties is the fact that in most cases the bending moment, the normal force, and the shear force in sections of the frame are obtained as small differences of large quantities.

Three methods of solving the linear equations are presented. The first is the solution by Southwell's method of systematic relaxations which is a procedure of step-by-step approximations. Four numerical examples give an indication how the individual steps in the relaxation procedure may be arranged so as to achieve a rapid convergence of the procedure. In most cases, however, it is not easy to find the proper succession of steps. Because of this, the procedure of the growing unit was devised. In this procedure, the individual beams are combined into units of increasing length until finally the entire frame becomes a single unit. In each step of the calculation not more than three simultaneous linear equations must be solved. Finally, the third method is the direct solution of the set of linear equations by means of the matrix calculus. The latter two procedures are straightforward and can theoretically always be carried out. The work involved, however, increases with the number of subdivisions chosen, and because of the small differences of large numbers occurring in the computations the use of calculating machines may become indispensable.

It is of interest to compare the numerical procedures here suggested with known methods of analysis of the bending moments in fuselage rings. Fully analytic methods have been published only for circular and elliptic rings for a restricted number of conditions of loading. Rings of arbitrary shape were discussed by Lundquist and Burke (reference 6),

Hoff (reference 7), and du Plantier (reference 8), rings with additional internal bracing elements by Lundquist and Burke (reference 6). Simple ring problems can be solved by any of these methods with comparative ease, so that the procedures suggested in this report show no particular advantages in these cases. The numerical procedures of this report become advantageous when one or more internal bracing elements are incorporated into the frame. The additional elements entail a slight increase in the work of setting up the operations table, but the solution of the equations does not necessitate any additional work. If the equations are solved by relaxations, the number of steps necessary may even become smaller. Since in the earlier methods the work involved in the calculations increases rapidly when redundant bracing elements are added to the frame, the advantage of using the procedures of this report increases with each added bracing element.

Polytechnic Institute of Brooklyn,
Brooklyn, New York, February 1945.

REFERENCES

1. Cross, Hardy, and Morgan, Newlin Dolby: Continuous Frames of Reinforced Concrete. John Wiley & Sons, Inc., 1932.
2. Southwell, R. V.: Relaxation Methods in Engineering Science. A Treatise on Approximate Computations, Clarendon Press (Oxford), 1940.
3. Hoff, N. J., Levy, Robert S., and Kempner, Joseph: Numerical Procedures for the Calculation of the Stresses in Monocoques. I - Diffusion of Tensile Stringer Loads in Reinforced Panels. NACA TN No. 934, 1944.
4. Hoff, N. J., and Kempner, Joseph: Numerical Procedures for the Calculation of the Stresses in Monocoques. II - Diffusion of Tensile Stringer Loads in Reinforced Flat Panels with Cut-Outs. NACA TN No. 950, 1944.
5. Hoff, N. J., Klein, Bertram, and Libby, Paul A.: Numerical Procedures for the Calculation of the Stresses in Monocoques. IV - Influence Coefficients of Curved Bars for Distortions in Their Own Plane. NACA TN No. 999, 1945.
6. Lundquist, Eugene E., and Burke, Walter F.: General Equations for the Stress Analysis of Rings. NACA Rep. No. 509, 1934.
7. Hoff, N. J.: Stress Analysis of Rings for Monocoque Fuselages. Jour. Aero. Sci., vol. 9, no. 7, May 1942, pp. 245-251.
8. duPlantier, Donald A.: Analysis of Fuselage Rings by the Column Analogy. Jour. Aero. Sci., vol. 11, no. 2, April 1944, pp. 137-152; see also Hoff, N. J., Letter to the Editor. Jour. Aero. Sci., vol. 11, no. 4, Oct. 1944, p. 338.
9. Newell, Joseph S.: The Use of Symmetric and Anti-Symmetric Loadings. Jour. Aero. Sci., vol. 6, no. 6, April 1939, pp. 235-239.
10. Wignot, J. E., Combs, Henry, and Ensrud, A. F.: Analysis of Circular Shell-Supported Frames. NACA TN No. 929, 1944.
11. Hoff, N. J.: Stresses in a Reinforced Monocoque Cylinder under Concentrated Symmetric Transverse Loads. Jour. Appl. Mech., vol. 11, no. 4, Dec. 1944, p. A-235.

APPENDIX

DIRECT SOLUTION OF A SYSTEM OF LINEAR EQUATIONS

As was shown in the body of this report, the operations table represents a set of simultaneous linear equations. The equations can be solved directly by the method of eliminations. The only difficulty lies in the great number of simultaneous equations and the corresponding great number of unknowns contained in the operations table. Because of these the numerical work is far too cumbersome unless the operations are carried out in a systematic manner. The systematic solution of sets of linear equations is one of the subjects of the matrix calculus. The elements of this discipline needed here are very simple. An attempt is made, therefore, to present them in an easily understandable manner.

First a set of linear equations will be solved by the methods of high school algebra. Then it will be shown that the same calculations can be carried out in a more concise manner through the use of the matrix calculus.

As an example, the following three equations containing three unknowns will be considered:

$$2x + y + z = 8 \quad (1a)$$

$$x + 2y + z = 9 \quad (1b)$$

$$x + y + 2z = 7 \quad (1c)$$

Divide equation (1a) by 2:

$$x + 0.5y + 0.5z = 4 \quad (2)$$

Subtract (2) from (1b):

$$1.5y + 0.5z = 5 \quad (3a)$$

Subtract (2) from (1c):

$$0.5y + 1.5z = 3 \quad (3b)$$

It may be seen that equations (3) do not contain x any more. Next y can be eliminated from equation (3b) if first equation (3a) is divided by 3:

$$0.5 y + 0.166 z = 1.66 \quad (4)$$

and subsequently equation (4) is subtracted from equation (3b):

$$1.333 z = 1.333 \quad (5)$$

Equations (5), (3a), and (1a) can now be easily solved for the unknowns. Obviously, equation (5) yields

$$z = 1 \quad (6)$$

Substitution of equation (6) in equation (3a) and solution for y gives

$$y = 3 \quad (7)$$

Finally equation (1a) yields after substitution of equations (6) and (7):

$$x = 2 \quad (8)$$

The same problem will now be solved using the matrix notation. The first achievement of the matrix calculus is economy of writing. As long as the first column always contains the x terms, the second the y terms, and the third the z terms, it is necessary to rewrite x , y , and z . The simultaneous equations are characterized by the set of coefficients arranged in an ordered array. Thus the left-hand members of equation (1) can be represented by the set

$$A = \begin{bmatrix} 2 & 1 & 1 \\ 1 & 2 & 1 \\ 1 & 1 & 2 \end{bmatrix} \quad (9)$$

It is customary to enclose the set of coefficients within brackets as shown in equation (9). A , or the set of coefficients in brackets, is known as a "matrix." The nine numbers in the brackets are the "elements" of the matrix.

The second important device in matrix calculus is the operation called "matrix multiplication." This operation is in many respects very different from what is known as multiplication in arithmetic and algebra. It would be better perhaps to coin a new word for this operation in order to avoid

misunderstanding. This would necessitate, however, the memorizing of some artificial expression. As things stand now, the operation is known as "multiplication" in mathematics, and engineers have to conform with the usage. They should remember, however, that matrix multiplication means the complex operation shown below, and not what someone might infer because of the familiar expression "multiplication."

The product of two matrices is again a matrix, the coefficients of which have to be calculated according to the following rule:

$$\begin{bmatrix} a_1 & a_2 & a_3 \\ b_1 & b_2 & b_3 \\ c_1 & c_2 & c_3 \end{bmatrix} \times \begin{bmatrix} d_1 & d_2 & d_3 \\ e_1 & e_2 & e_3 \\ f_1 & f_2 & f_3 \end{bmatrix} = \begin{bmatrix} g_1 & g_2 & g_3 \\ h_1 & h_2 & h_3 \\ j_1 & j_2 & j_3 \end{bmatrix} \quad (10)$$

where

$$\left. \begin{aligned} g_1 &= a_1 d_1 + a_2 e_1 + a_3 f_1 \\ g_2 &= a_1 d_2 + a_2 e_2 + a_3 f_2 \\ g_3 &= a_1 d_3 + a_2 e_3 + a_3 f_3 \\ h_1 &= b_1 d_1 + b_2 e_1 + b_3 f_1 \\ h_2 &= b_1 d_2 + b_2 e_2 + b_3 f_2 \\ &\vdots \\ j_3 &= c_1 d_3 + c_2 e_3 + c_3 f_3 \end{aligned} \right\} \quad (11)$$

The rule shown in equations (10) and (11) can easily be extended to square matrices of any order. The "order" of a square matrix is equal to the number of rows (or columns) in the matrix. Two examples of matrix multiplication are given below:

$$\begin{bmatrix} 1 & 3 \\ 2 & 4 \end{bmatrix} \times \begin{bmatrix} 5 & 6 \\ 1 & 2 \end{bmatrix} = \begin{bmatrix} (1 \times 5) + (3 \times 1), & (1 \times 6) + (3 \times 2) \\ (2 \times 5) + (4 \times 1), & (2 \times 6) + (4 \times 2) \end{bmatrix} = \begin{bmatrix} 8 & 12 \\ 14 & 20 \end{bmatrix}$$

$$\begin{bmatrix} 1 & 0 & 0 & 0 \\ 1 & 1 & 0 & 0 \\ 0 & 0 & 1 & 1 \\ 0 & 0 & 0 & 1 \end{bmatrix} \times \begin{bmatrix} 1 & 1 & 1 & 1 \\ 2 & 1 & 0 & 0 \\ 0 & 0 & 2 & 0 \\ 0 & 0 & 0 & 2 \end{bmatrix} = \begin{bmatrix} 1 & 1 & 1 & 1 \\ 3 & 2 & 1 & 1 \\ 0 & 0 & 2 & 2 \\ 0 & 0 & 0 & 2 \end{bmatrix}$$

It should be noted that, in general, the "matrix product" changes if the factors in the product (that is, the two matrices) are interchanged. For instance

$$\begin{bmatrix} 1 & 2 \\ 1 & 1 \end{bmatrix} \times \begin{bmatrix} 3 & 0 \\ 2 & 1 \end{bmatrix} = \begin{bmatrix} 7 & 2 \\ 5 & 1 \end{bmatrix} \quad (12a)$$

$$\begin{bmatrix} 3 & 0 \\ 2 & 1 \end{bmatrix} \times \begin{bmatrix} 1 & 2 \\ 1 & 1 \end{bmatrix} = \begin{bmatrix} 3 & 6 \\ 3 & 5 \end{bmatrix} \quad (12b)$$

In equation (12a) the matrix

$$\begin{bmatrix} 3 & 0 \\ 2 & 1 \end{bmatrix}$$

is said to be "premultiplied," in equation (12b) "postmultiplied" by the matrix

$$\begin{bmatrix} 1 & 2 \\ 1 & 1 \end{bmatrix}$$

With the aid of the multiplication rule of matrices, equations (1) may now be written in the following form:

$$[x, y, z] \times \begin{bmatrix} 2 & 1 & 1 \\ 1 & 2 & 1 \\ 1 & 1 & 2 \end{bmatrix} = [8, 9, 7] \quad (13)$$

The "row matrix" $[x, y, z]$ is identical with the square matrix

$$\begin{bmatrix} x & y & z \\ 0 & 0 & 0 \\ 0 & 0 & 0 \end{bmatrix}$$

Application of the multiplication rule to the left-hand member of equation (13) yields

$$\begin{bmatrix} x & y & z \\ 0 & 0 & 0 \\ 0 & 0 & 0 \end{bmatrix} \times \begin{bmatrix} 2 & 1 & 1 \\ 1 & 2 & 1 \\ 1 & 1 & 2 \end{bmatrix} = \begin{bmatrix} (2x + y + z) & (x + 2y + z) & (x + y + 2z) \\ 0 & 0 & 0 \\ 0 & 0 & 0 \end{bmatrix} \quad (14)$$

The right-hand member of equation (14) can be written as a row matrix

$$[(2x + y + z), (x + 2y + z), (x + y + 2z)]$$

so that equation (13) is equivalent to

$$[(2x + y + z), (x + 2y + z), (x + y + 2z)] = [8, 9, 7] \quad (15)$$

Equation (15) expresses the equality of two matrices. Matrices are considered equal if, and only if, all their corresponding elements are equal. If one equates corresponding elements of the matrices on the two sides of the equality sign of equation (15), the following algebraic equations are obtained:

$$\begin{aligned} 2x + y + z &= 8 \\ x + 2y + z &= 9 \\ x + y + 2z &= 7 \end{aligned} \quad (1)$$

which are indeed identical with equations (1).

It should be noted that when the matrix equation (13) is transformed into three simultaneous algebraic equations, the

matrix is read "downward," not from the left to the right, in agreement with the rules of matrix multiplication. For instance, the matrix equation

$$[x, y, z] \times \begin{bmatrix} 1 & 2 & 3 \\ 5 & 4 & 2 \\ 2 & 3 & 2 \end{bmatrix} = [1, 0, 3]$$

is equivalent to the three algebraic equations

$$x + 5y + 2z = 1$$

$$2x + 4y + 3z = 0$$

$$3x + 2y + 2z = 3$$

and not to

$$x + 2y + 3z = 1$$

$$5x + 4y + 2z = 0$$

$$2x + 3y + 2z = 3$$

This distinction cannot be noticed in the case of equation (13), since there the square matrix is "symmetric," which means that elements in it are equal if they are symmetrically situated to the principal diagonal. The "principal diagonal" of a square matrix is the diagonal passing from top left to bottom right.

The following results of matrix multiplication are worth noting:

(1) The matrix

$$I_3 = \begin{bmatrix} 1 & 0 & 0 \\ 0 & 1 & 0 \\ 0 & 0 & 1 \end{bmatrix}$$

is called the "identity matrix" of the third order. The matrix

$$I_2 = \begin{bmatrix} 1 & 0 \\ 0 & 1 \end{bmatrix}$$

is the identity matrix of the second order. An identity matrix of any other order is defined in a similar manner: It is a square matrix having 1 for its principal diagonal elements, and 0 for all the other elements. Now, application of the rule of matrix multiplication shows that

$$\begin{bmatrix} 7 & 4 & 1 \\ 5 & 5 & 7 \\ 1 & 2 & 3 \end{bmatrix} \times \begin{bmatrix} 1 & 0 & 0 \\ 0 & 1 & 0 \\ 0 & 0 & 1 \end{bmatrix} = \begin{bmatrix} 7 & 4 & 1 \\ 5 & 5 & 7 \\ 1 & 2 & 3 \end{bmatrix}$$

and

$$\begin{bmatrix} 1 & 0 & 0 \\ 0 & 1 & 0 \\ 0 & 0 & 1 \end{bmatrix} \times \begin{bmatrix} 3 & 3 & 3 \\ 2 & 0 & 1 \\ 1 & 2 & 3 \end{bmatrix} = \begin{bmatrix} 3 & 3 & 3 \\ 2 & 0 & 1 \\ 1 & 2 & 3 \end{bmatrix}$$

It can be seen that any square matrix remains unchanged upon premultiplication or postmultiplication by the identity matrix of the same order.

(2) Multiplication yields

$$\begin{bmatrix} 1 & 2 & 3 \\ 0 & 2 & 0 \\ 3 & 3 & 1 \end{bmatrix} \times \begin{bmatrix} 1 & 1 & 0 \\ 0 & 1 & 0 \\ 0 & 0 & 1 \end{bmatrix} = \begin{bmatrix} 1 & 3 & 3 \\ 0 & 2 & 0 \\ 3 & 6 & 1 \end{bmatrix}$$

In other words, postmultiplication by the matrix

$$\begin{bmatrix} 1 & 1 & 0 \\ 0 & 1 & 0 \\ 0 & 0 & 1 \end{bmatrix}$$

left the first and third columns of the first matrix unchanged, and transformed the second column into the sum of the original first and second columns. In a similar way, it can be seen that

$$\begin{bmatrix} 2 & 0 & 0 \\ 8 & 1 & 1 \\ 4 & 3 & 2 \end{bmatrix} \times \begin{bmatrix} 1 & 0.5 & 0 \\ 0 & 1 & 0 \\ 0 & 0 & 1 \end{bmatrix} = \begin{bmatrix} 2 & 1 & 0 \\ 8 & 5 & 1 \\ 4 & 5 & 2 \end{bmatrix}$$

or in other words, postmultiplication by the matrix

$$\begin{bmatrix} 1 & 0.5 & 0 \\ 0 & 1 & 0 \\ 0 & 0 & 1 \end{bmatrix}$$

left the first and third columns of the first matrix unchanged, and transformed the second column into the sum of the original second column and one-half of the original first column. Also,

$$\begin{bmatrix} 2 & 0 & 1 \\ 0 & 3 & 2 \\ 1 & 0 & 3 \end{bmatrix} \times \begin{bmatrix} 1 & 0 & 0 \\ 0 & 1 & 3 \\ 0 & 0 & 1 \end{bmatrix} = \begin{bmatrix} 2 & 0 & 1 \\ 0 & 3 & 11 \\ 1 & 0 & 3 \end{bmatrix}$$

Hence, postmultiplication by the matrix

$$\begin{bmatrix} 1 & 0 & 0 \\ 0 & 1 & 3 \\ 0 & 0 & 1 \end{bmatrix}$$

left the first and second columns of the first matrix unchanged, and transformed the third column into the sum of the original third, and three times the original second columns. It may be stated, therefore:

Postmultiplication by a matrix in which all principal diagonal elements are unity, the element in the p th row and q th column is k , and all the other elements are zero, is equivalent to an addition to the q th column of the original matrix of k times the p th column of the original matrix.

The effect of several nonvanishing elements off the principal diagonal can be understood from the example:

$$\begin{bmatrix} 1 & 2 & 1 \\ 0 & 2 & 1 \\ 2 & 0 & 1 \end{bmatrix} \times \begin{bmatrix} 1 & 1 & 0 \\ 0 & 1 & 2 \\ 0 & 0 & 1 \end{bmatrix} = \begin{bmatrix} 1 & 3 & 5 \\ 0 & 2 & 5 \\ 2 & 2 & 1 \end{bmatrix}$$

Here, postmultiplication by the matrix

$$\begin{bmatrix} 1 & 1 & 0 \\ 0 & 1 & 2 \\ 0 & 0 & 1 \end{bmatrix}$$

left the first column unchanged, added to the second column the first column, and added to the third column the double of the second column. The knowledge gained from these examples may be utilized in the transformation of a set of linear equations.

In order to solve the matrix equation (13) for the unknowns x , y , and z , both sides of the equation are first postmultiplied by the matrix

$$M_1 = \begin{bmatrix} 1 & -0.5 & -0.5 \\ 0 & 1 & 0 \\ 0 & 0 & 1 \end{bmatrix} \quad (16)$$

Postmultiplication means that M_1 is written as a factor behind the members of the equation:

$$[x, y, z] \times \begin{bmatrix} 2 & 1 & 1 \\ 1 & 2 & 1 \\ 1 & 1 & 2 \end{bmatrix} \begin{bmatrix} 1 & -0.5 & -0.5 \\ 0 & 1 & 0 \\ 0 & 0 & 1 \end{bmatrix} = [8, 9, 7] \times \begin{bmatrix} 1 & -0.5 & -0.5 \\ 0 & 1 & 0 \\ 0 & 0 & 1 \end{bmatrix} \quad (17)$$

It was shown in equations (12) that the order of factors in a matrix product is of great importance. The result of a postmultiplication differs, in general, from those of a "premultiplication" in which latter the same factor M_1 would be written before the members of equation (13). The rule for the construction of M_1 is as follows:

- (1) Fill in the principal diagonal; that is, the diagonal of the matrix running from top left to bottom right, with the digit 1;
- (2) Fill in the remaining places in the first row with the corresponding values of the original matrix divided by the first element in the first row of the original matrix (in the present example 2) and by -1;
- (3) All the remaining elements of M_1 are to be filled in with 0.

If the matrix multiplication is carried out, the following result is obtained

$$[x, y, z] \times \begin{bmatrix} 2 & 0 & 0 \\ 1 & 1.5 & 0.5 \\ 1 & 0.5 & 1.5 \end{bmatrix} = [8, 5, 3] \quad (18)$$

This equation can be written in an equivalent row matrix form, if so desired:

$$[(2x + y + z), (1.5y + 0.5z), (0.5y + 1.5z)] = [8, 5, 3] \quad (19)$$

The matrix equation is again equivalent to three algebraic equations

$$\begin{aligned} 2x + y + z &= 8 \\ 1.5y + 0.5z &= 5 \\ 0.5y + 1.5z &= 3 \end{aligned} \quad (20)$$

It will be recognized that the first of equations (20) is the same as the first of equations (1), while the second and the third of equations (20) are identical with equations (3a) and (3b), respectively. In other words, postmultiplication by M_1 achieved exactly the same transformation of the system of equations as did the algebraic operation that originally resulted in equations (3).

The matrix operations can now be continued by the application of one more postmultiplier M_2 defined as

$$M_2 = \begin{bmatrix} 1 & 0 & 0 \\ 0 & 0 & -0.33 \\ 0 & 0 & 1 \end{bmatrix} \quad (21)$$

Postmultiplication of equation (18) is indicated as follows:

$$[x, y, z] \times \begin{bmatrix} 2 & 0 & 0 \\ 1 & 1.5 & 0.5 \\ 1 & 0.5 & 1.5 \end{bmatrix} \times \begin{bmatrix} 1 & 0 & 0 \\ 0 & 1 & -0.33 \\ 0 & 0 & 1 \end{bmatrix} = [8, 5, 3] \times \begin{bmatrix} 1 & 0 & 0 \\ 0 & 1 & -0.33 \\ 0 & 0 & 1 \end{bmatrix} \quad (22)$$

When it is carried out, the result is:

$$[x, y, z] \times \begin{bmatrix} 2 & 0 & 0 \\ 1 & 1.5 & 0 \\ 1 & 0.5 & 1.333 \end{bmatrix} = [8, 5, 1.333] \quad (23)$$

Equation (23) may be written in the row-matrix form:

$$[(2x + y + z), (1.5y + 0.5z), (1.333z)] = [8, 5, 1.333] \quad (24)$$

This matrix equation is equivalent to the three simultaneous algebraic equations

$$2x + y + z = 8$$

$$1.5y + 0.5z = 5 \quad (25)$$

$$1.333z = 1.333$$

Comparison reveals that the first two of equations (25) are identical with the first two of equations (20). Consequently, the first of equations (25) is the same as the first of equation (1), and the second of equations (25) is the same as equation (3a). The third of equations (25) is identical with equation (5).

Thus, it has been shown that the two matrix multiplications indicated in equations (17) and (22), respectively, result in the same set of linear equations as those obtained by the use of methods of high school algebra. The characteristic property of the set of equations (25) is that the last equation contains one, the middle one two, and the first one three unknowns. Because of this property the equations can be easily solved one by one, as was done in equations (6) to (8). The square matrix in equation (23) is just a convenient representation of the left-hand member of equations (25). It falls into the category known as "triangular" matrices because all its elements are zero on one side of the principal diagonal.

It is, therefore, the purpose of the postmultiplications to transform the original matrix into a triangular matrix, which can be solved then by elementary algebra without any difficulty.

The procedure as developed here may seem to be lengthy. A considerable part of the material presented, however, was purely explanatory and can be omitted from the actual calculations. The essential features were:

- (1) Representation of the equations by the matrix of the coefficients of the unknowns

$$\begin{bmatrix} 2 & 1 & 1 \\ 1 & 2 & 1 \\ 1 & 1 & 2 \end{bmatrix} \quad (a)$$

and by the row matrix of the right-hand side

$$[8 \quad 9 \quad 7] \quad (b)$$

(2) Construction of the postmultiplier

$$M_1 = \begin{bmatrix} 1 & -0.5 & -0.5 \\ 0 & 1 & 0 \\ 0 & 0 & 1 \end{bmatrix} \quad (c)$$

according to the rules

- (a) Elements of the principal diagonal have the value 1;
- (b) Elements of the first row off the principal diagonal are equal to the corresponding elements of the original matrix divided by the principal diagonal element of the first row and by -1;
- (c) All other elements are 0.

(3) Postmultiplication by M_1 of both the square matrix and the row matrix:

$$\begin{bmatrix} 2 & 1 & 1 \\ 1 & 2 & 1 \\ 1 & 1 & 2 \end{bmatrix} \times \begin{bmatrix} 1 & -0.5 & -0.5 \\ 0 & 1 & 0 \\ 0 & 0 & 1 \end{bmatrix} = \begin{bmatrix} 2 & 0 & 0 \\ 1 & 1.5 & 0.5 \\ 1 & 0.5 & 1.5 \end{bmatrix} \quad (d)$$

$$[8, 9, 7] \times \begin{bmatrix} 1 & -0.5 & -0.5 \\ 0 & 1 & 0 \\ 0 & 0 & 1 \end{bmatrix} = [8, 5, 3] \quad (e)$$

(4) In all the later operations undertaken, the first column and the first row of the right-hand member of equation (d) remain unchanged. It is, therefore, permissible to omit them from the further considerations and to center the attention upon the two-by-two square "submatrix" obtained by striking out the first column and the first row:

$$\begin{bmatrix} 1.5 & 0.5 \\ 0.5 & 1.5 \end{bmatrix} \quad (f)$$

This submatrix has to be postmultiplied by the matrix M^*_2 constructed exactly according to the prescription contained in (2):

$$M^*_2 = \begin{bmatrix} 1 & -0.33 \\ 0 & 1 \end{bmatrix} \quad (g)$$

It may be noted that M^*_2 can be obtained from M_2 (see equation (21)) by striking out the first column and the first row.

Postmultiplication results in

$$\begin{bmatrix} 1.5 & 0.5 \\ 0.5 & 1.5 \end{bmatrix} \times \begin{bmatrix} 1 & -0.33 \\ 0 & 1 \end{bmatrix} = \begin{bmatrix} 1.5 & 0 \\ 0.5 & 1.333 \end{bmatrix} \quad (h)$$

(5) In a similar manner the first element can be omitted from the row matrix of the right-hand member of equation (e). The submatrix so obtained is

$$[5, 3] \quad (j)$$

It must be postmultiplied by M^*_2 :

$$[5, 3] \times \begin{bmatrix} 1 & -0.33 \\ 0 & 1 \end{bmatrix} = [5, 1.333] \quad (k)$$

(6) The complete transformed square matrix consists of the first row and the first column of the right-hand side

member of equation (d), and of the right-hand side member of equation (h):

$$\begin{bmatrix} 2 & 0 & 0 \\ 1 & 1.5 & 0 \\ 1 & 0.5 & 1.333 \end{bmatrix} \quad (l)$$

(7) The complete transformed row matrix consists of the first element of the right-hand side member of equation (e), and of the right-hand side member of equation (h):

$$[8, 5, 1.333] \quad (m)$$

(8) The complete transformed matrix equation can be written as a combination of (l) and (m) as follows:

$$[x, y, z] \times \begin{bmatrix} 2 & 0 & 0 \\ 1 & 1.5 & 0 \\ 1 & 0.5 & 1.333 \end{bmatrix} = [8, 5, 1.333] \quad (n)$$

This equation is identical with equation (23) and can be solved as explained below equation (23).

The operations outlined in the preceding eight points can be arranged concisely according to the following scheme:

8	9	7		
2	1	1	-0.5	-0.5
1	2	1	1	0
1	1	2	0	1
5			3	
	1.5	0.5	-0.33	
	0.5	1.5	1	
		1.33		
		1.33		

The first line in the scheme represents the original row matrix (b). Below it is arranged the original square matrix (a). To the right is the postmultiplier (c) except that its first column is omitted. This first column is not needed since it would enter only in the calculation of the first column of the matrix product which need not be rewritten since it remains unchanged as explained under (4).

The values under the first full horizontal line are obtained by postmultiplying the row matrix [8, 9, 7] by the incomplete postmultiplier. This postmultiplication is carried out exactly according to the rules of matrix multiplication given earlier. Because of the incompleteness of the postmultiplier only two elements are obtained in the product. The first is

$$[8 \times (-0.5)] + (9 \times 1) + (7 \times 0) = 5$$

the second

$$[8 \times (-0.5)] + (9 \times 0) + (7 \times 1) = 3$$

Since the omitted first column of the postmultiplier contained the elements 1, 0, 0, multiplication by it would have given 8, the unchanged value of the first element of the row matrix. This need not be rewritten.

The square matrix under the row 5, 3 is computed in a similar manner by postmultiplying the original square matrix by the incomplete postmultiplier. Multiplication of the row 2, 1, 1 would give:

$$[2 \times (-0.5)] + (1 \times 1) + (1 \times 0) = 0$$

$$[2 \times (-0.5)] + (1 \times 0) + (1 \times 1) = 0$$

These two zeros need not be listed. Multiplication of the second row yields

$$[1 \times (-0.5)] + (2 \times 1) + (1 \times 0) = 1.5$$

$$[1 \times (-0.5)] + (2 \times 0) + (1 \times 1) = 0.5$$

These two values are listed in the first row below the dotted line. The elements in the second row are obtained in a similar manner:

$$[1 \times (-0.5)] + (1 \times 1) + (2 \times 0) = 0.5$$

$$[1 \times (-0.5)] + (1 \times 0) + (2 \times 1) = 1.5$$

The column to the right is the second column of the post-multiplier (g). The first column of this postmultiplier is again omitted as unessential for the computations.

The last two numbers in the scheme are computed by multiplication by the incomplete second postmultiplier in the same manner as described in connection with the preceding operations.

It must be emphasized that the scheme given does not contain a complete presentation of the matrix multiplications. It is just a convenient short-hand reproduction of the computations given in more detail under (1) to (8). Familiarity with this scheme of operations makes it possible to reduce quickly, with the least amount of time wasted in writing, a given set of linear equations to the diagonal form.

An example is now given, without explanations, for the reduction of a set of four equations.

The equations are:

$$4x + 2y + z = 11$$

$$2x + 3y + 2w = 16$$

$$x + 2z + w = 11$$

$$2y + z + w = 11$$

The computations can be arranged as follows:

11	16	11	11			
4	2	1	0	-0.5	-0.25	0
2	3	0	2	1	0	0
1	0	2	1	0	1	0
0	2	1	1	0	0	1
	10.5	8.25	11			
	2	-0.5	2	0.25	-1	
	-0.5	1.75	1	1	0	
	2	1	1	0	1	
	10.875	0.5				
	1.625	1.5		-0.923		
	1.5	-1		1		
				-9.55		
						-2.385

Hence, the transformed set of equations can be written in the matrix form as follows:

$$[x, y, z, w] \times \begin{bmatrix} 4 & 0 & 0 & 0 \\ 2 & 2 & 0 & 0 \\ 1 & -0.5 & 1.625 & 0 \\ 0 & 2 & 1.5 & -2.385 \end{bmatrix} = [11, 10.5, 10.875, -9.55]$$

This matrix equation is equivalent to the four algebraic equations:

$$4x + 2y + z = 11$$

$$2y - 0.5z + 3w = 10.5$$

$$1.625z + 1.5w = 10.875$$

$$-2.385w = -9.55$$

The last one of the equations gives immediately

$$w = 4$$

Substitution in the preceding equation yields

$$1.625z = 10.875 - 6 = 4.875$$

Hence,

$$z = 3$$

Substitution of w and z in the second equation results in

$$2y = 10.5 - 3 + 1.5 = 4$$

Consequently,

$$y = 2$$

Finally, there is obtained

$$4x = 11 - 3 - 4 = 4$$

and thus,

$$x = 1$$

When the number of simultaneous linear equations is large, the computational work is greatly reduced by the use of a calculating machine. A calculating machine may become necessary also for reasons of accuracy, when the computations

happen to involve small differences of large numbers. An example is now given for the solution of seven equations with seven unknowns. The equations represent the problem of the egg-shape ring with symmetric loads.

In this example, as in all the matrix computations of this report, the work of writing was further reduced by the adoption of the following scheme. Instead of writing out the entire matrix multiplier, only the first row is put down, and even the first element of the first row is omitted. It may be remembered that all the elements omitted are either equal to unity, or to zero.

The first row in table 17 contains (-1) times the external loads of the egg-shape ring with symmetric loads. The following seven rows, under the dotted line, are identical with the rows of the operations table (table 6). The next row, under the solid line and included in parentheses, presents the multipliers. They are (-1) times the ratios obtained by dividing the elements of the first row under the dotted line, except the first element of this row, by the first element of the first row. The first ratio, $-(8.92216)/(-3.34833) = 2.66466$, is listed in the second column (in the column of 8.92216). The other ratios follow in the third, fourth, and so forth, columns.

The row under the ratios contains the transformed external loads. The value in the *i*th column of this row is obtained by multiplying the first element in the first row of the table by the multiplier in the *i*th column and adding to the product algebraically the value of the element in the first row and the *i*th column. Thus, for instance, in the second column the value 133.233 was calculated as follows:

$$2.66466 \times 50 + 0 = 133.233$$

It may be seen that in this manner only six transformed external load elements are obtained from the original seven external load elements.

Following the same rule, the original seven-by-seven matrix is transformed into the six-by-six matrix contained between the second dotted line and the second full ones. For instance, the element in the fourth column and the thirteenth row of the entire table was computed as follows:

$$3.96771 \times 1.18498 = 30.9566 = -26.2549$$

This scheme is followed until the external load elements are reduced to a single element, and the matrix is also reduced to a single element. The leading columns represent then the equations of the triangular system. For instance, the leading column of the third step may be written as

$$-1.77854 v_p + 0.204688 u_p - 8.96572 w_c + 0.775767 v_0 = -38.3834$$

The leading column of the sixth step is:

$$-1.034845 v_c - 0.654970 u_c = -19.2443$$

The full set of these equations can be solved as shown earlier.

As a second example of the procedure actually used in the calculations, table 18 is presented. It contains the transformation of the matrix of the circular ring with anti-symmetric loads.

More information on matrices, written from the standpoint of the person interested in applications of the matrix calculus to problems in physics and engineering, may be found in "Elementary Matrices and Some Applications to Dynamics and Differential Equations" by R. A. Frazer, W. J. Duncan, and A. R. Collar (University Press, 1938). The procedure used in the present report can be shortened further if advantage is taken of the fact that all the matrices discussed in this report can be set up in a symmetric form. Such a simplified procedure was suggested by M. H. Doolittle in "Method Employed in the Solution of Normal Equations and the Adjustment of a Triangulation," U. S. Coast and Geodetic Survey Report, 1878, pp. 115-120. A discussion of the Doolittle technique may be found in an article by Paul S. Dwyer in the December 1941 issue of the Annals of Mathematical Statistics, Vol. XII, No. 4, pp. 449-458. A more modern approach to the solution of simultaneous equations arising in engineering is given in the paper "A Short Method for Evaluating Determinants and Solving Systems of Linear Equations with Real or Complex Coefficients" by Prescott D. Crout, Transactions A. I. E. E., vol. 60, 1941, p. 1235.

Table 6. Operations Table

Operation	R_A	N_B	R_B	T_B	N_C	R_C	T_C
[1] $v_A=10^{-4}$ in.	-3.34833	8.92216	-2.69614	3.96771			
[2] $w_B=10^{-4}$ rad.	8.92216	-327.866	11.4697	-13.1014	-61.242	8.10267	0
[3] $v_B=10^{-4}$ in.	-2.69614	11.4697	-4.00991	3.4352	-8.10267	0.66158	
[4] $u_B=10^{-4}$ in.	3.96771	-13.1014	3.4352	-30.9566	0	0	26.2058
[5] $w_C=10^{-4}$ rad.		-61.242	-8.10267	0	-288.367	-2.95522	-5.24667
[6] $v_C=10^{-4}$ in.		8.10267	0.66158	0	-2.95622	-1.90205	-0.88929
[7] $u_C=10^{-4}$ in.		0	0	26.2058	-5.24667	- .88929	-27.0833

The notation adopted for the displacements is as follows: u stands for a tangential, v for a radial displacement, w for a rotation. The subscript refers to the point that moves:

Table 10. Operations Table

Operation	R_A	N_B	R_B	T_{BC}	N_C	R_C
$v_A = 10^{-4}$ in.	-8.3726365	31.372640	-7.6032219	10.097316		
$w_B = 10^{-4}$ rad.	31.372640	-479.93253	33.93750	-40.987910	-81.64964	10
$v_B = 10^{-4}$ in.	-7.6032219	33.93750	-9.1891329	9.4690625	-10	0.8164964
$u_B = u_C = 10^{-4}$ in.	10.097316	-40.987910	9.4690625	-13.515682	-8.855104	-1.3664455
$w_C = 10^{-4}$ rad.		-81.64964	-10	-8.855104	-354.21850	-5.791741
$v_C = 10^{-4}$ in.		10	0.8164964	-1.3664455	-5.791741	-2.6516009

Table 11. Operations table for circular ring

Operation	N_A in.-lb.	T_A lb.	N_B in.-lb.	R_B lb.	T_B lb.	N_C in.-lb.	T_C lb.
[1] $w_A=10^{-3}$ rad.	-281.95	-49.079	-29.966	-4.733	64.675		
[2] $u_A=10^{-3}$ in.	-49.079	-52.296	64.675	-22.441	51.516		
[3] $w_B=10^{-3}$ rad.	-29.966	64.675	-439.849	31.443	-50.642	56.5117	6.632
[4] $v_B=10^{-3}$ in.	-4.733	-22.441	31.443	-12.338	20.14	8.842	0.524
[5] $u_B=10^{-3}$ in.	64.675	51.516	-50.642	20.14	-52.618	6.632	0.0685
[6] $w_C=10^{-3}$ rad.			56.5117	8.842	6.632	-157.899	-1.563
[7] $u_C=10^{-3}$ in.			6.632	0.524	0.0685	-1.563	-0.322

Table 12. Relaxation Table for Circular Ring

Operation	N _A in.-lb.	T _A lb.	N _B in.-lb.	R _B lb.	T _B lb.	N _C in.-lb.	T _C lb.
External loads	-1.835	-8.747	-54.970	59.476	38.104	-53.135	-23.860
0.42[6]			23.75	3.71	2.78	-66.4	-0.655
-76.2[7]	-1.84	-8.75	-31.22 -505	63.19 -39.9	40.88 -5.21	-119.5 119.2	-24.5 24.6
-2.0[3]	-1.84 60.0	-8.75 -129.4	-536.2 880	23.3 -62.8	35.67 101.2	-0.3 -113.0	0.1 -13.26
1[1]	58.2 -282	-138.15 -49.1	343.8 -30.0	-39.5 -4.7	136.87 64.7	-113.3	-13.2
-60[7]	-223.8	-187.3	313.8 -398.0	-44.2 -31.4	201.6 -4.1	-113.3 93.9	-13.2 19.3
-0.35[6]	-223.8	-187.3	-84.2 -19.8	-75.6 -3.1	197.5 -2.3	-19.4 55.4	6.1 0.55
-0.90[3]	-223.8 27.0	-187.3 -58.3	-104.0 396	-78.7 -28.3	195.2 45.5	36.0 -50.9	6.65 -5.96
0.1[1]	-196.8 -28.2	-245.6 -4.9	292 -3.0	-107.0 -0.5	240.7 6.5	-14.9	0.69
-0.1[6]	-225.0	-250.5	289 -5.6	-107.5 -0.9	247.2 -0.7	-14.9 15.8	0.69 0.16
-0.06[3]	-225.0 1.8	-250.5 -3.9	283 28.4	-108.4 -1.9	246.5 3.04	0.9 -3.24	0.87 -0.04
0.05[1]	-223.2 -14.1	-254.4 -2.5	31.14 -1.5	-110.3 -0.2	249.54 3.23	-2.34	0.83
-4.87[2]	-237.3 239	-256.9 255	309.9 -316	-110.5 109.3	252.77 -251	-2.34	0.83
Results of a check table	1.6 1.637	-1.9 -1.944	-6.1 -7.246	-1.2 -1.37	1.77 1.969	-2.34 -2.792	0.83 0.412

Table 13. Operations Table for Braced Circular Ring

Operation	N_A In.-lb.	T_A lb.	N_B in.-lb.	R_B lb.	T_B lb.	N_C in.-lb.	T_C lb.
[1] $w_A = 10^{-3}$ rad.	-281.95	-49.079	-29.966	-4.7334	64.675		
[2] $v_A = 10^{-3}$ in.	-49.079	-52.296	64.675	-22.441	51.516		
[3] $w_B = 10^{-3}$ rad.	-29.966	64.675	-453.287	31.2348	-50.1390	49.8388	7.134970
[4] $v_B = 10^{-3}$ in.	-4.7334	-22.441	31.2348	-29.6649	12.9752	8.63405	7.709565
[5] $u_B = 10^{-3}$ in.	64.675	51.516	-50.1390	12.9752	-55.6152	7.134970	3.015452
[6] $w_C = 10^{-3}$ rad.			49.8388	8.63405	7.13497	-171.337	-1.06003
[7] $u_C = 10^{-3}$ in.			7.134970	7.709565	3.015452	-1.06003	-3.31919

Table 14. Relaxation Table for Braced Circular Ring

Operation	N _A in.-lb.	T _A lb.	N _B in.-lb.	R _B lb.	T _B lb.	N _C in.-lb.	T _C lb.
External loads	-1.835	-8.747	-54.970	59.476	38.104	-53.135	-23.860
-0.4[6]			-19.92	-3.45	-2.85	68.6	0.424
-8.3[7]	-1.835	-8.75	-74.89	56.026	35.254	15.46	-23.436
			-59.15	-64.05	-25.1	8.80	27.6
-0.375[3]	-1.835	-8.75	-134.04	-8.02	10.1	24.26	4.2
	11.25	-24.25	170.0	-11.70	18.8	-18.70	-2.67
0.1[1]	9.41	-33.0	36.0	-19.72	28.9	5.56	1.5
	-28.2	-4.9	-3.0	0.47	6.5		
-0.24[4]	-18.79	-37.9	33.0	-19.25	35.4	5.56	1.5
	1.14	5.4	-7.5	7.13	-3.1	-2.07	-1.85
-0.05[3]	-17.65	-32.5	25.5	-12.12	32.3	3.49	-0.35
	1.50	-3.24	22.6	-1.56	2.5	-2.49	-0.356
0.084[1]	-16.15	-35.74	48.1	-13.68	34.8	1.00	-0.706
	-18.05	-3.14	-1.92	-0.3	4.15		
0.1[4]	-34.2	-38.88	46.2	-13.98	38.95	1.00	-0.706
	-0.47	-2.24	3.1	-2.97	1.30	0.86	0.771
0.01[1]	-34.67	-41.12	49.3	-16.95	40.25	1.86	0.065
	-2.82	-0.49	-0.3	-0.05	0.65		
-0.795[2]	-37.49	-41.61	49.0	-17.00	40.90	1.86	0.065
	39.1	41.6	-51.5	17.8	-41.0		
	1.6	0	-2.5	0.8	-0.1	1.86	0.065
Results of a check table	1.5217	-.05656	-2.4849	-.072270	0.01066	1.8078	0.00159

Table 15. Operations Table for Torsion of Egg-Shaped Ring

Operation	N_A in.-lb.	T_A lb.	N_B in.lb.	R_B lb.	T_B lb.	N_C in.-lb.	R_C lb.	T_{CD} lb.	N_C in.-lb.	R_D lb.
$w_A = 10^{-3}$ rad.	-523.185	-217.240	178.054	-82.8465	234.496					
$v_A = 10^{-3}$ in.	-217.240	-175.295	234.496	-79.8920	174.431					
$w_B = 10^{-3}$ rad.	178.054	234.496	-1606.64	-291.974	-1496.08	367.170	-278.790	1314.66		
$v_B = 10^{-3}$ in.	-82.8465	-79.8920	-291.974	-248.18	-660.021	278.790	-185.110	744.755		
$u_B = 10^{-3}$ in.	234.49-	174.431	-1496.08	-660.021	-2955.38	1314.66	-744.755	2778.29		
$w_C = 10^{-3}$ rad.			367.17	278.790	1314.66	-1246.76	403.048	-1278.84	-81.3496	10
$v_C = 10^{-3}$ in.			-278.790	-185.110	-744.755	403.048	-211.246	738.001	-10	0.816490
$u_{CD} = 10^{-3}$ in.			1314.66	744.755	2778.29	-1278.84	738.001	-2781.37	-8.85510	-1.36345
$w_D = 10^{-3}$ rad.						-81.6496	-10	-8.85510	-354.218	-5.79174
$v_D = 10^{-3}$ in.						10	0.816496	-1.36645	-5.79174	-2.6516

Table 16. Operations Table for Torsion of Braced Egg-Shaped Ring

Operation	N_A in.-lb.	T_A lb.	N_B in.-lb.	R_B lb.	T_B lb.	N_C in.-lb.	R_C lb.	T_{CD} lb.	N_D in.-lb.	R_D lb.
$w_A = 10^{-3}$ rad.	-523.185	-217.240	178.054	-82.8465	234.496					
$u_A = 10^{-3}$ in.	-217.240	-175.295	234.496	-79.8920	174.431					
$w_B = 10^{-3}$ rad.	178.054	234.496	-1614.32	-292.08	-1495.94	367.17	-278.79	1314.66		
$v_B = 10^{-3}$ in.	-82.8465	-79.8920	-292.08	-255.880	-665.458	278.790	-185.110	744.755		
$u_B = 10^{-3}$ in.	234.496	174.431	-1495.94	-665.458	-2959.23	1314.66	-744.755	2778.29		
$w_C = 10^{-3}$ rad.			367.17	278.790	1314.66	-1246.76	403.048	-1278.84	-81.6496	10
$v_C = 10^{-3}$ in.			-278.790	-185.110	-744.755	403.048	-211.246	738.001	-10	0.816496
$u_C = 10^{-3}$ in.			1314.66	744.755	2778.29	-1278.84	738.001	-2781.37	-8.85510	-1.36645
$w_D = 10^{-2}$ rad.						-81.6496	-10	-8.85510	-354.218	-5.79174
$v_D = 10^{-3}$ in.						10	0.816496	-1.36645	-5.79174	-2.6516

Table 17. Matrix Solution of Egg-Shaped Ring With Symmetric Loads

	R _A	N _B	R _B	T _B	N _C	R _C	T _C
v _A w _A v _B u _B v _B w _B v _C u _C	50	0	0	0	0	0	0
	-3.34833	8.92216	-2.69614	3.96771	0	0	0
	8.92216	-327.866	11.4697	-13.1014	-61.242	8.10267	0
	-2.69614	11.4697	-4.00991	3.4352	-8.10267	0.66158	0
	3.96771	-13.1014	3.4352	-30.9566	0	0	26.2058
	0	-61.242	-8.10267	0	-288.367	-2.95622	-5.24667
	0	8.10267	0.66158	0	-2.95622	-1.90205	-0.88929
	0	0	0	26.2058	-5.24667	-0.88929	-27.0833
v _B w _B v _B u _B v _C w _C v _C u _C	(2.66466	-0.805219	1.18498	0	0	0	0)
	133.233	-40.2610	59.249	0	0	0	0
	-304.091	4.2854	-2.52882	-61.242	8.10267	0	0
	4.28540	-1.83893	0.240328	-8.10267	0.66158	0	0
	-2.52880	0.240325	-26.2549	0	0	26.2058	26.2058
	-61.242	-8.10267	0	-288.367	-2.95622	-5.24667	-5.24667
	8.10267	0.66158	0	-2.95622	-1.90205	-0.88929	-0.88929
	0	0	26.2058	-5.24667	-0.88929	-27.0833	-27.0833
v _B w _B v _C u _C	(.0140925	-.0083159	-.2013936	.0266455	0	0	0)
	-38.3834	58.1410	-26.8323	3.55006	0	0	0
	-1.77854	0.20469	-8.96572	.775767	0	0	0
	0.204688	-26.2339	0.50928	-.0673811	26.2058	26.2058	26.2058
	-8.96572	.509282	-276.033	-4.58804	-5.24667	-5.24667	-5.24667
	0.775767	-.0673810	-4.588046	-1.68615	-0.88929	-0.88929	-0.88929
0	26.2058	-5.24667	-0.88929	-27.0833	-27.0833	-27.0833	
u _B w _C v _C u _C	(.1150888	-5.041056	0.4361819	0	0	0	0)
	53.7235	166.661	-13.1921	0	0	0	0
	-26.2103	-0.52256	.0219001	26.2058	26.2058	26.2058	26.2058
	-0.52257	-230.836	-8.49872	-5.24667	-5.24667	-5.24667	-5.24667
	.021901	-8.49873	-1.34777	-0.88929	-0.88929	-0.88929	-0.88929
26.2058	-5.24667	-0.88929	-27.0833	-27.0833	-27.0833	-27.0833	
w _C v _C u _C	(-.0199372	.000835549	0.999828	0	0	0	0)
	165.590	-13.1472	53.71426	0	0	0	0
	-230.826	-8.49916	-5.76905	0	0	0	0
	-8.49917	-1.34779	-0.867393	0	0	0	0
-5.76914	-0.867394	-0.882007	0	0	0	0	
v _C u _C	(-.0368206	-.02499353	0	0	0	0	0)
	-19.2443	49.57559	0	0	0	0	0
	-1.034545	-0.654970	0	0	0	0	0
-0.654970	-0.737816	0	0	0	0	0	
u _C	(-.632915)	0	0	0	0	0	0)
	61.75560	0	0	0	0	0	0
0.3232757	0	0	0	0	0	0	

Table 18. Matrix Solution for Circular Ring With Antisymmetric Loads

N_A	T_A	N_B	R_B	T_C
1.83507 -281.950 -49.079 -29.966 -4.7334 64.675	8.74715 -49.079 -52.296 64.675 -22.441 51.516	54.9703 -29.966 64.675 -453.287 31.2348 -50.1390	-59.4762 -4.7334 -22.441 31.2348 -29.6649 12.9752	-38.1038 64.675 51.516 -50.1390 12.9752 -55.6152
	(-.17407 8.4277 -43.7528 69.89118 -21.61706 40.25804	-.10628 54.77527 69.89118 -450.1022 31.7379 -57.0127	-.016788 -59.5070 -21.61706 31.7379 -29.5854 11.88943	.2293846 -37.6829 40.2580 -57.01275 11.88943 -40.7797
		(1.59744 68.23776 -338.457 -2.7934 7.29590	-.894073 -63.6709 -2.7934 -18.9050 -8.00098	0.920124 -29.92837 7.29580 -8.00095 -3.73731
			(-.00825334 -64.23409 -18.88195 -8.06119	.02155606 -28.4574 -8.06116 -3.58004
				(-0.4269241 -1.03431 -.13852

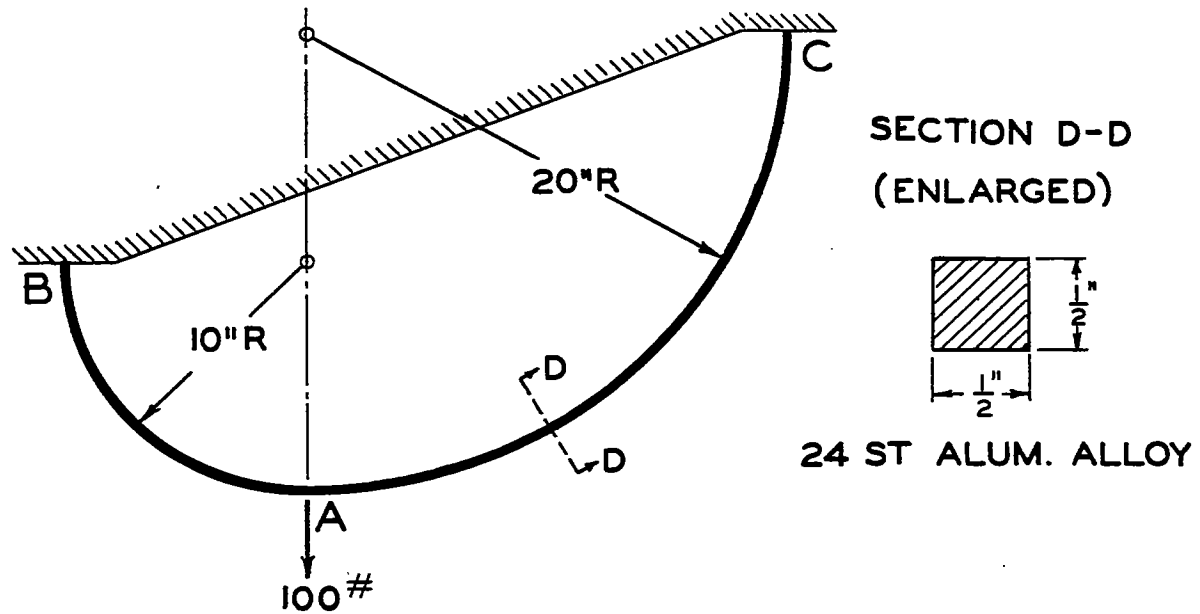

FIG. 1. CURVED BEAM.

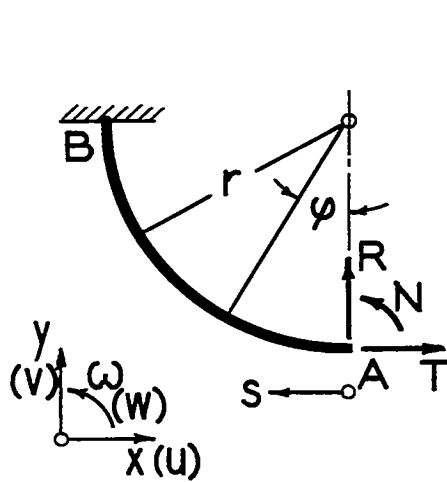

FIG. 2. ARC AB.

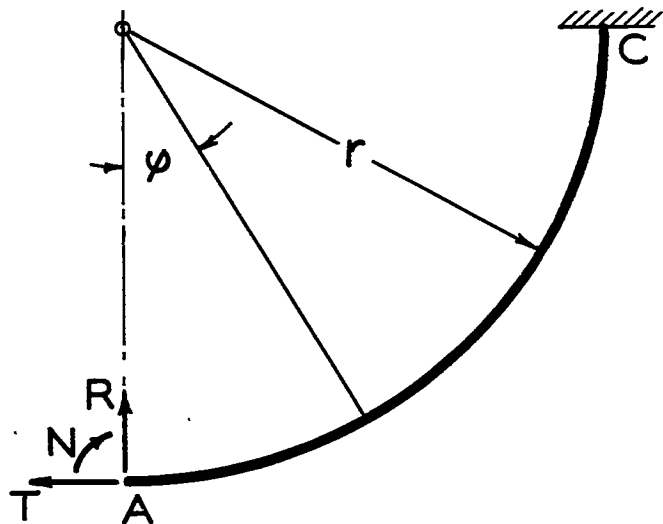
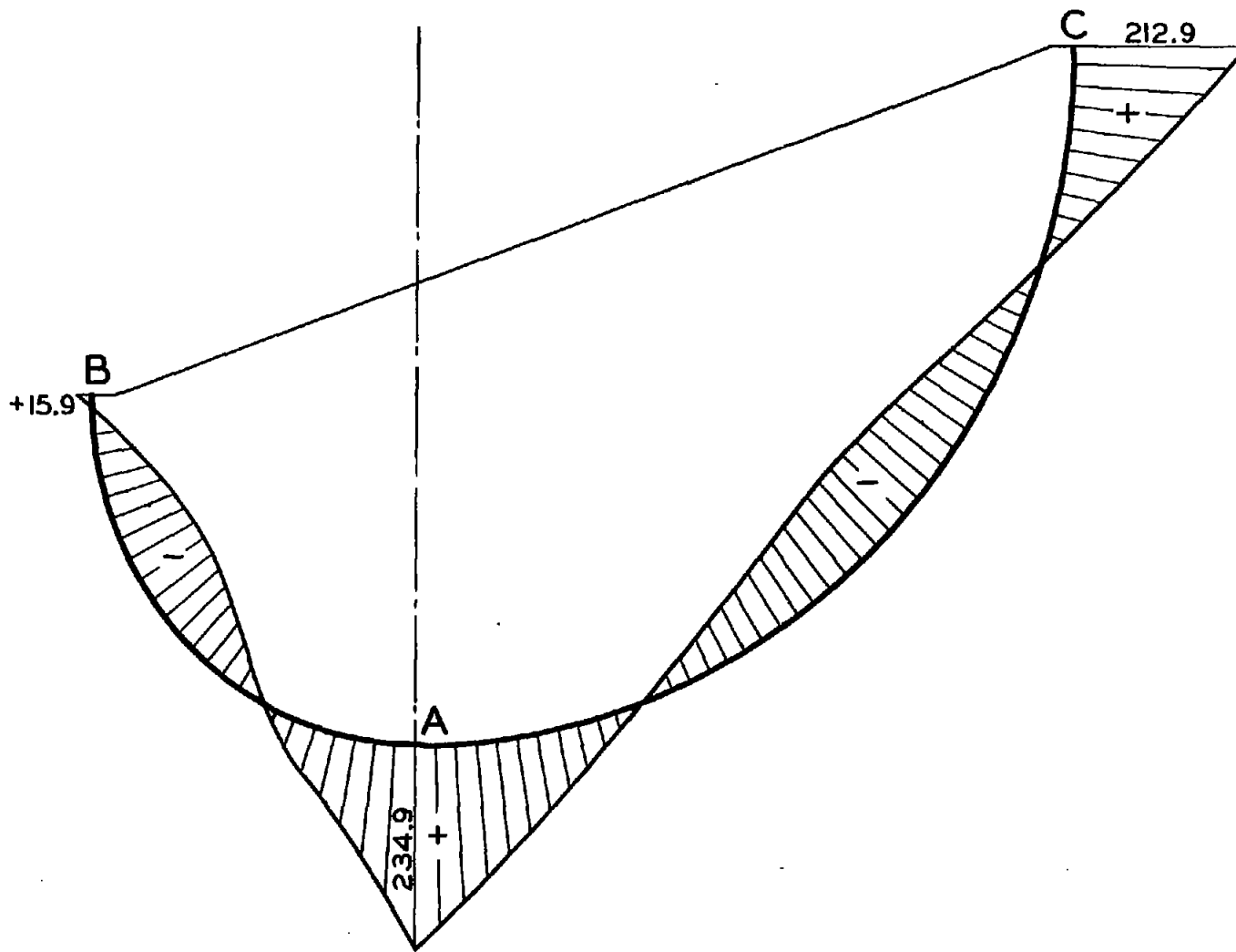

FIG. 3. ARC AC.



NACA TN No. 998

Fig. 4

FIG. 4. BENDING MOMENT DISTRIBUTION IN CURVED BEAM.

Fig. 5

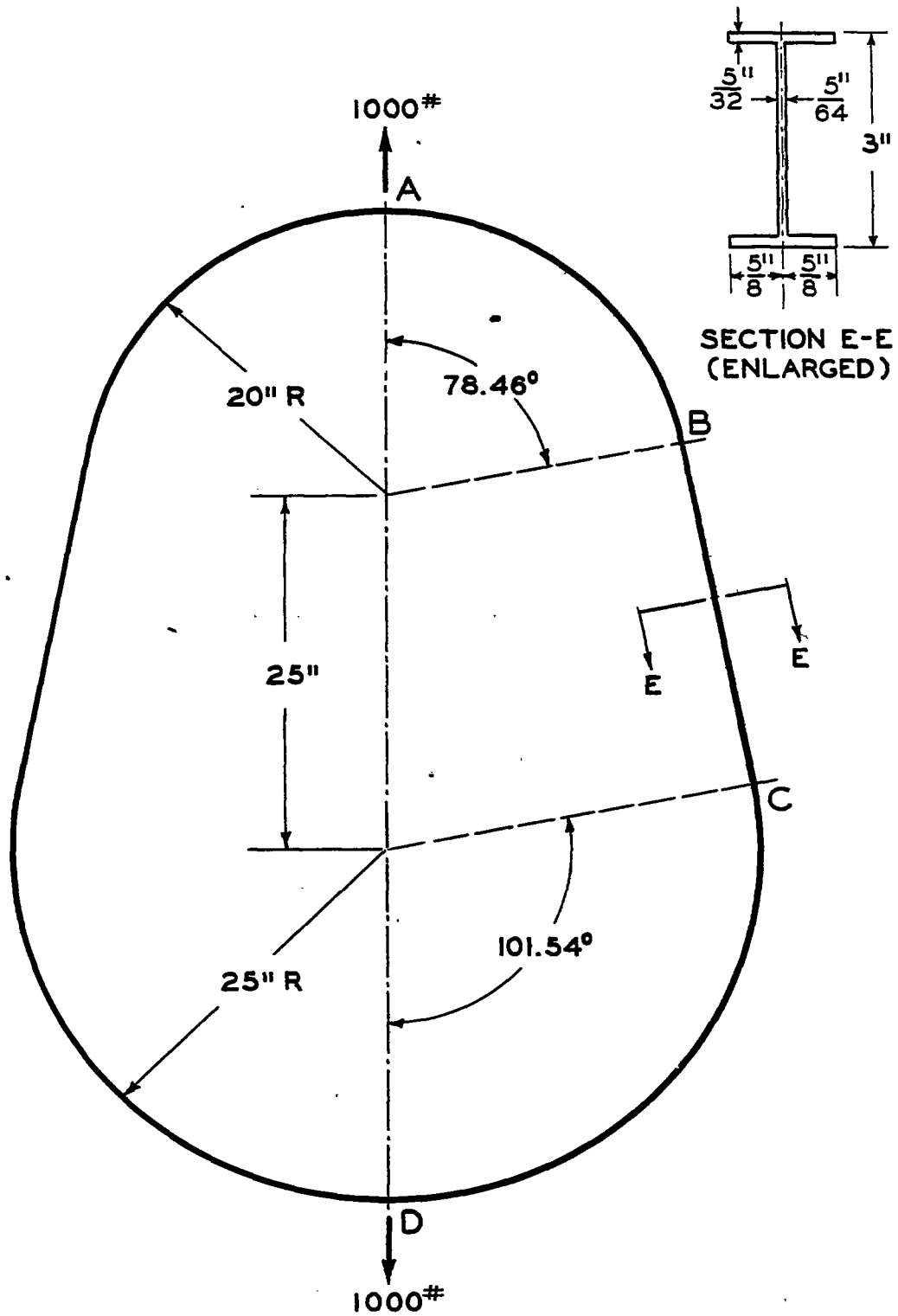

FIG.5 EGG-SHAPED RING WITH SYMMETRIC LOADS.

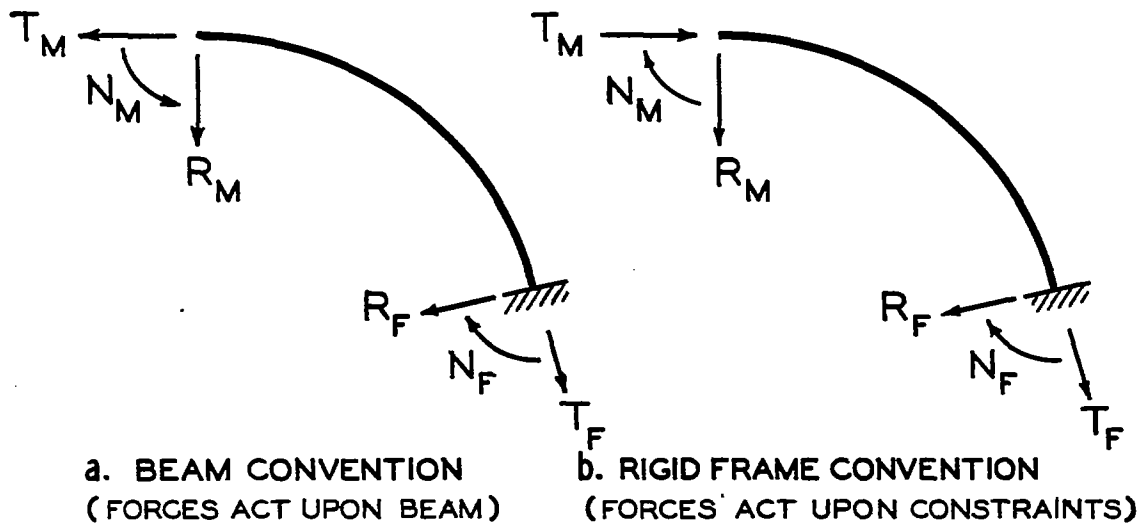

FIG. 6 SIGN CONVENTIONS FOR FORCES AND MOMENTS.

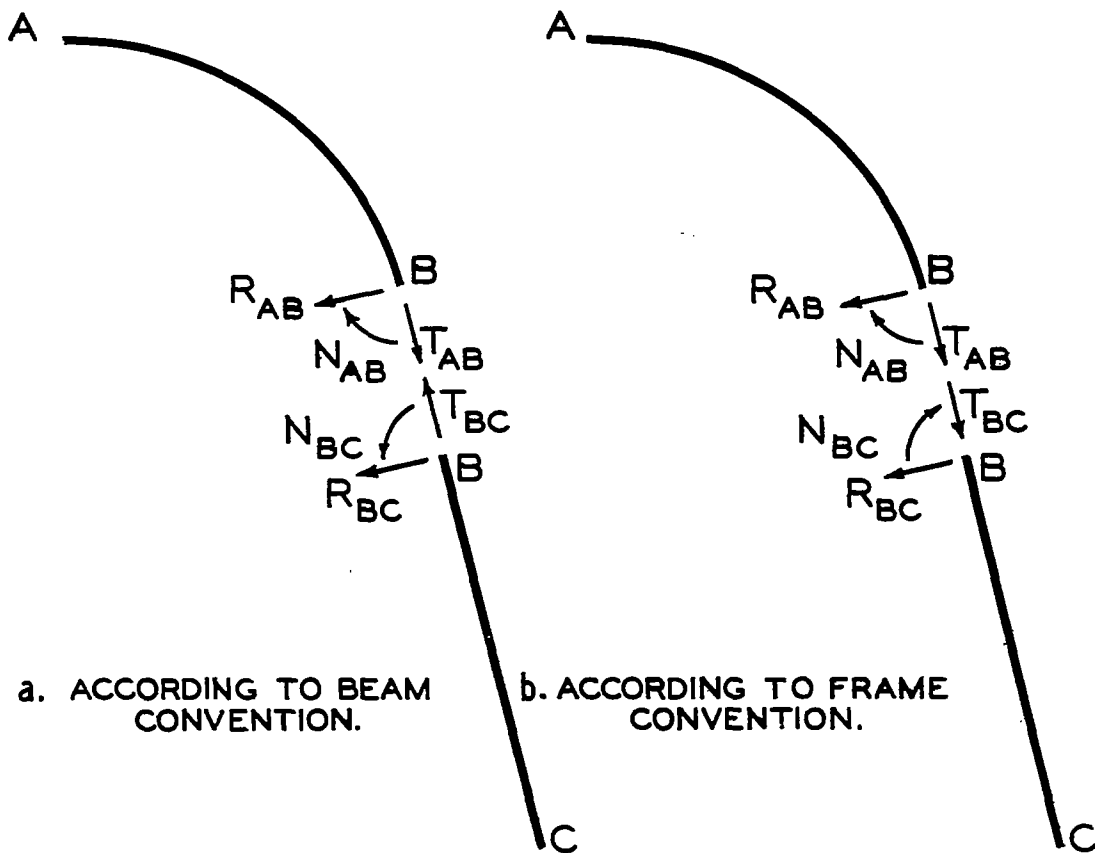

FIG. 7 POSITIVE FORCES AND MOMENTS AT POINT B.

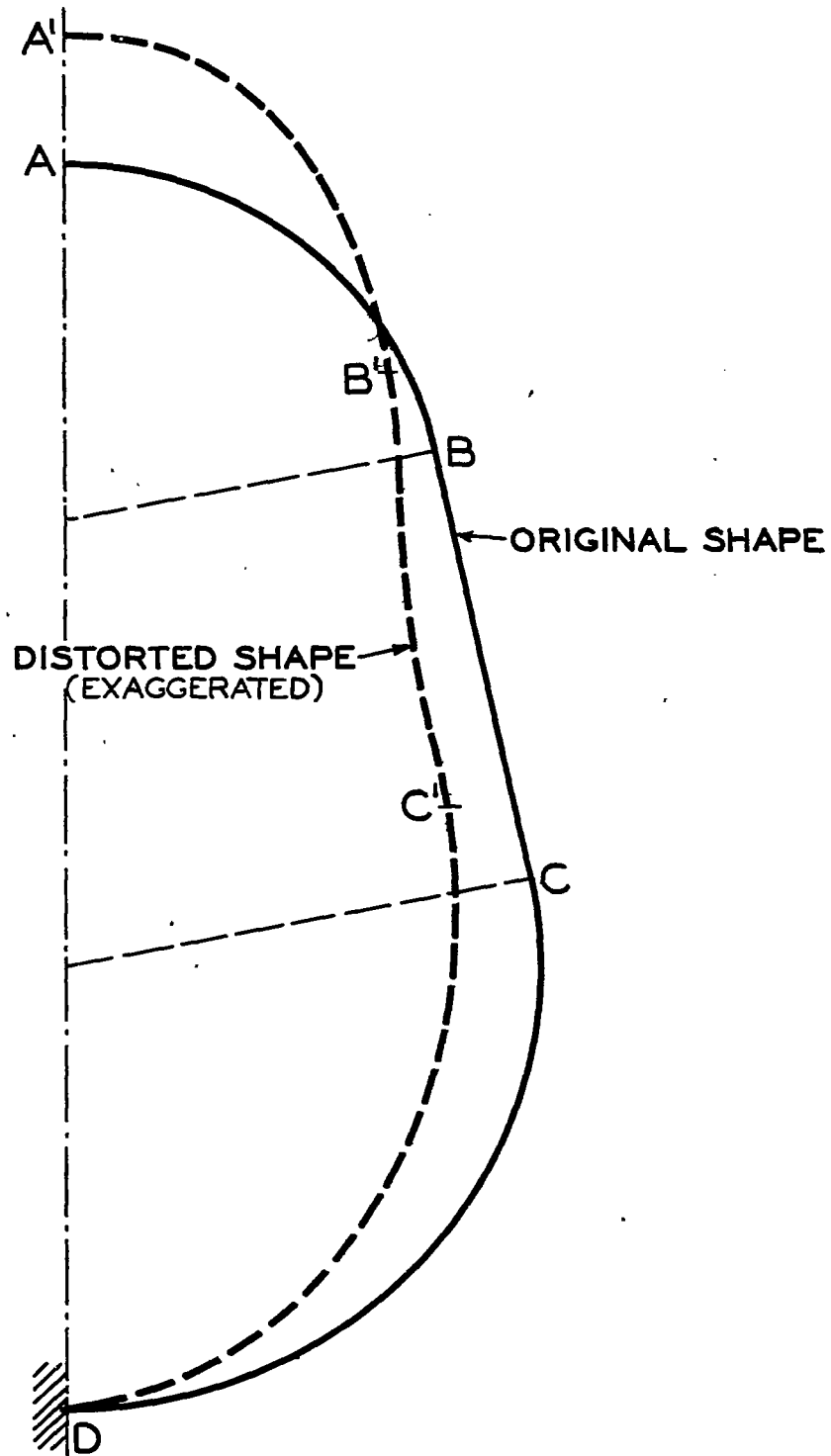

FIG. 8 DEFLECTED SHAPE OF EGG-SHAPED RING WITH SYMMETRIC LOADS.

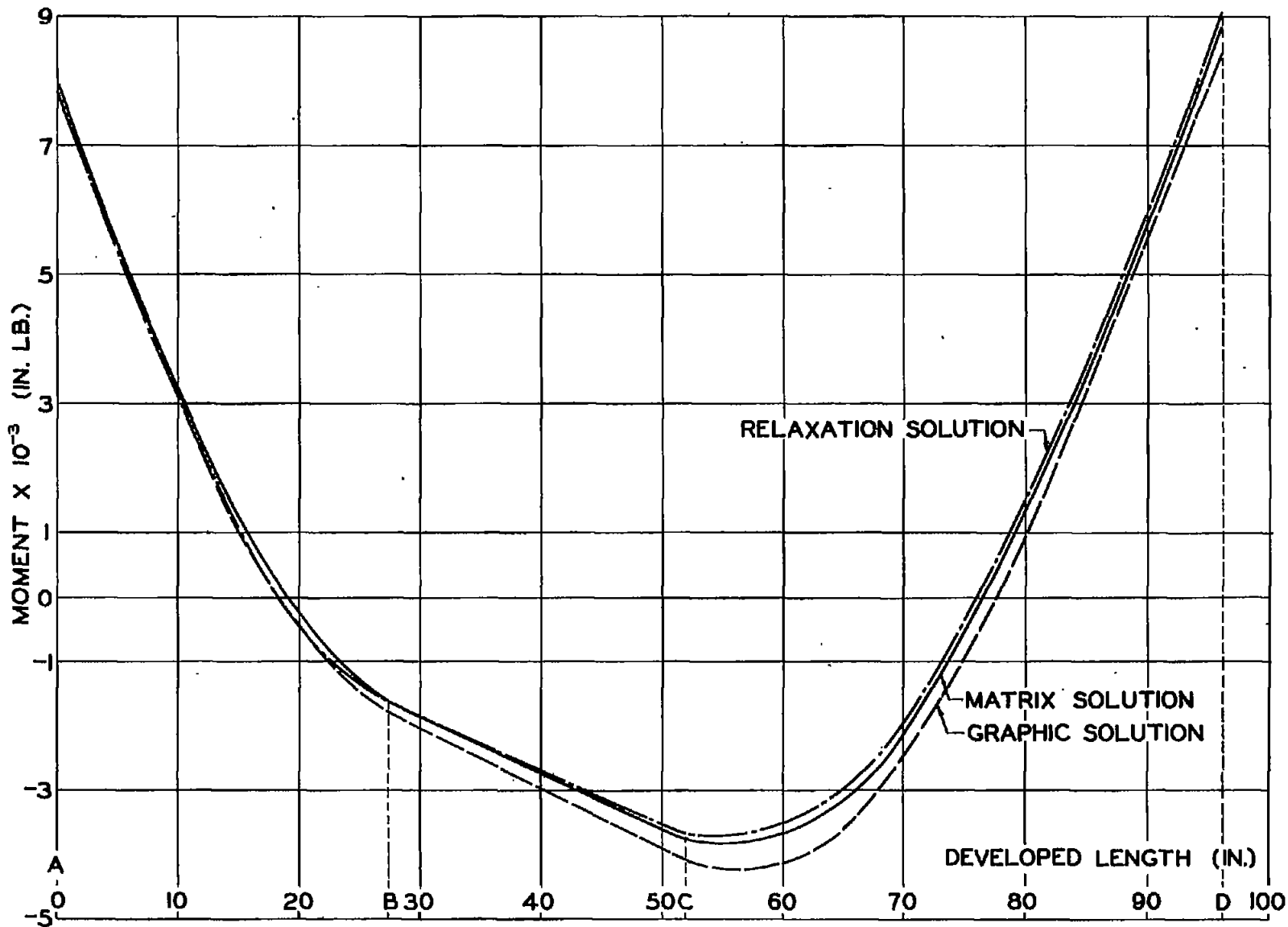

FIG. 9. BENDING MOMENT DISTRIBUTION OF EGG-SHAPED RING WITH SYMMETRIC LOADS.

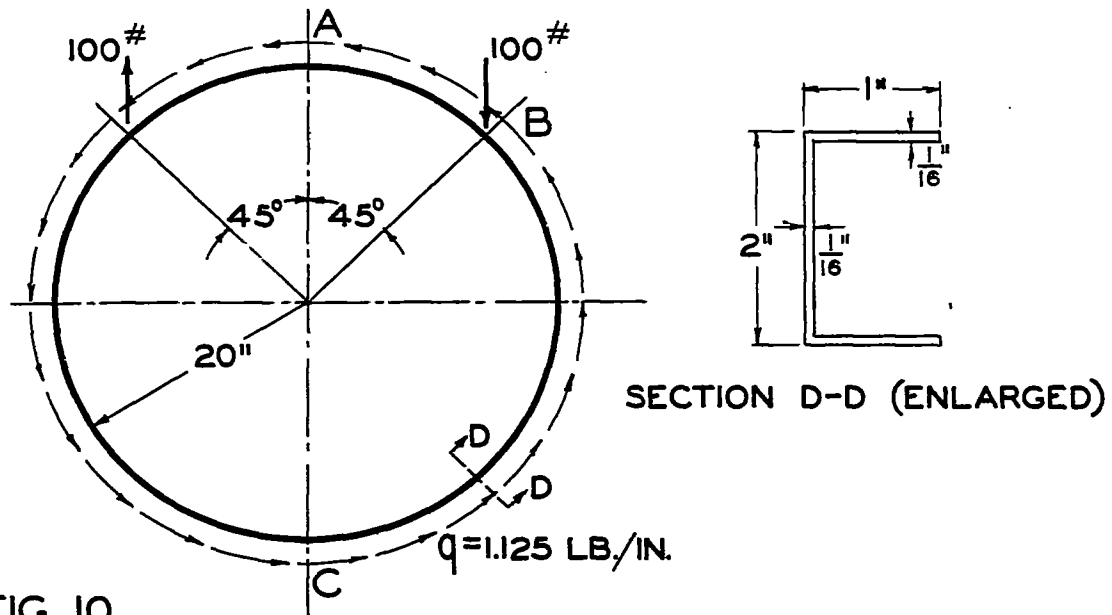

FIG. 10.

CIRCULAR RING WITH ANTISYMMETRIC LOADS.

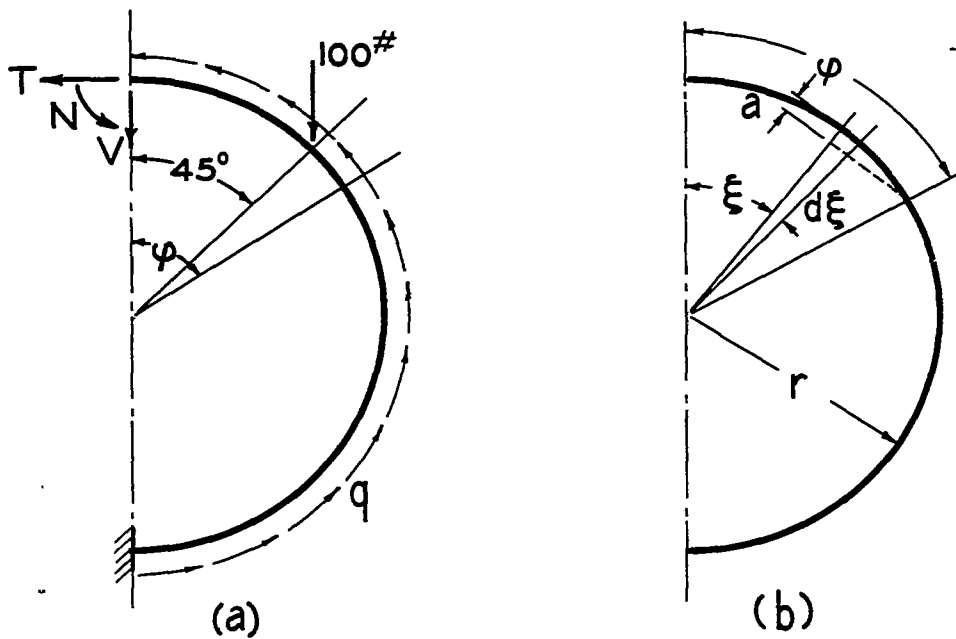

FIG. 11.

NOTATION FOR ANALYTIC SOLUTION OF RING PROBLEM.

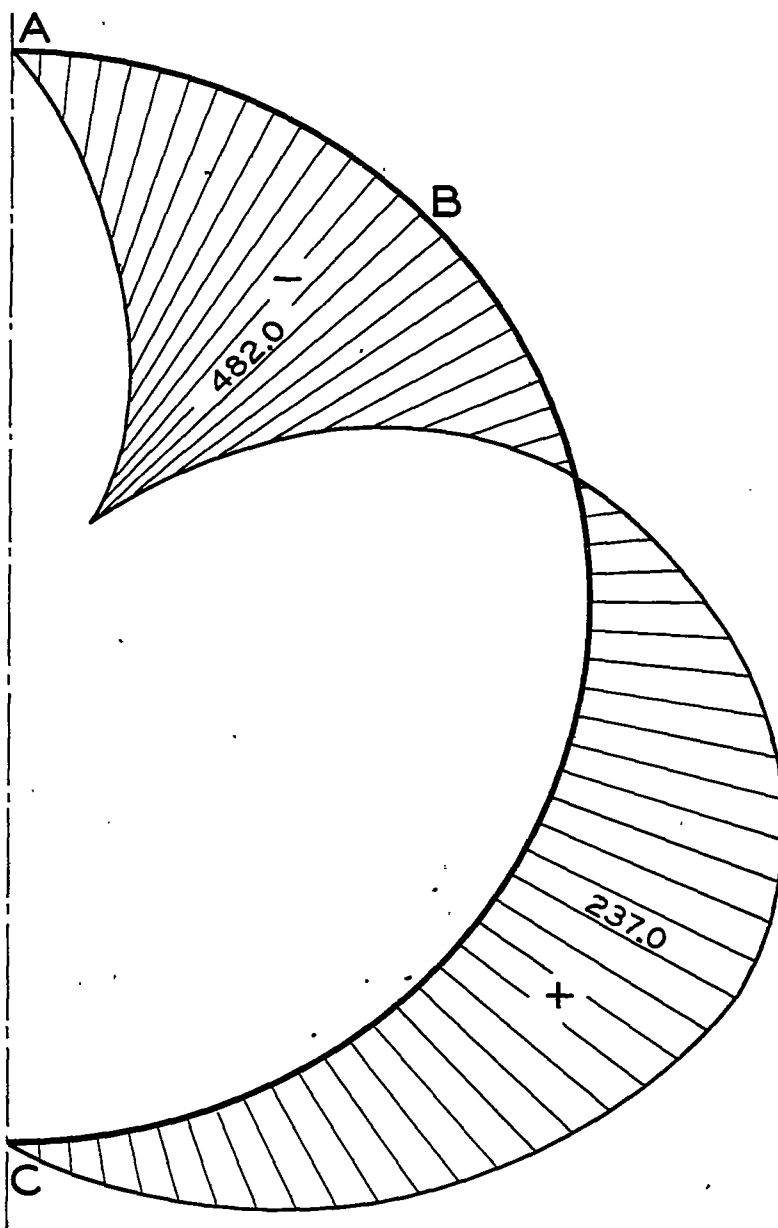

FIG. 12.

BENDING MOMENT DISTRIBUTION IN CIRCULAR RING.

NACA TN No. 998

Figs. 13,14

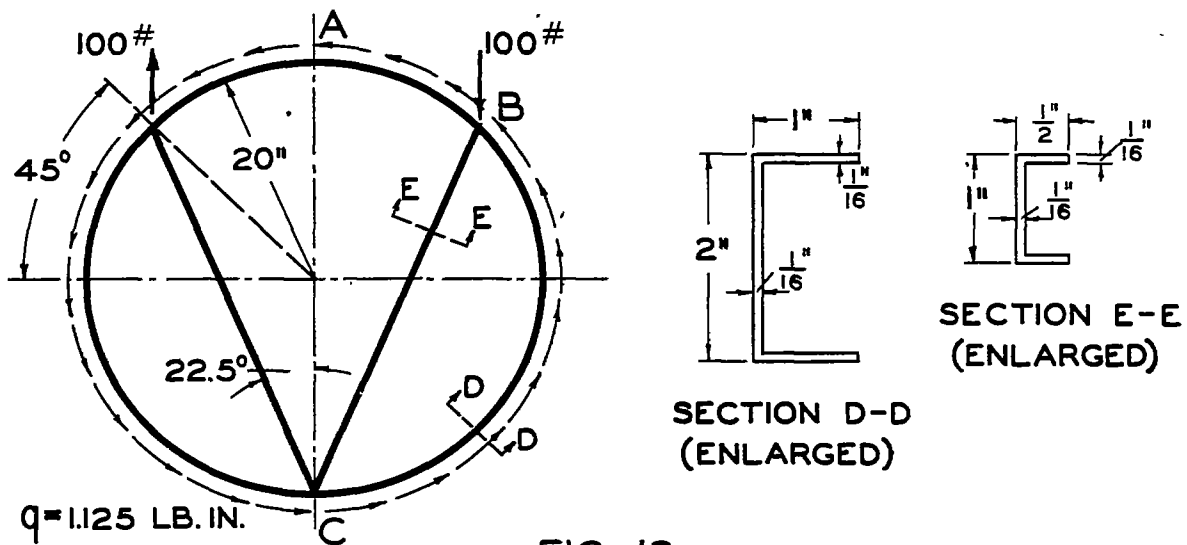
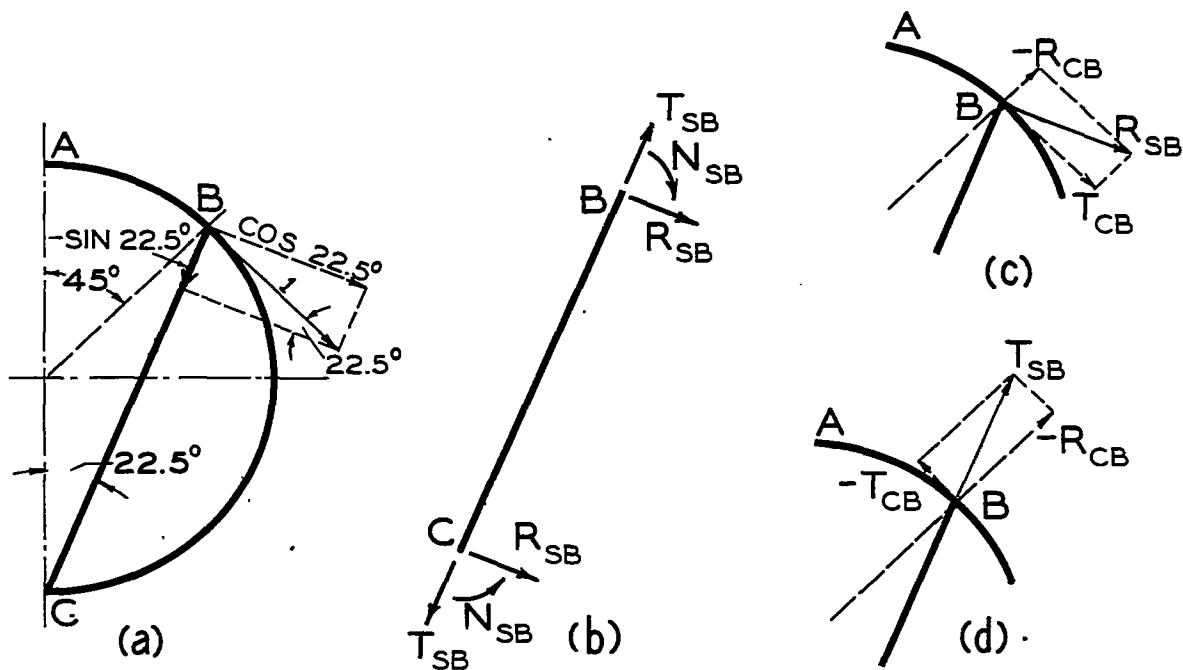

FIG. 13.

BRACED CIRCULAR RING WITH ANTISYMMETRIC LOADS.



- (a) RESOLUTION OF TANGENTIAL DISPLACEMENT.
- (b) BEAM CONVENTION FOR STRAIGHT BAR.
- (c) RESOLUTION OF RADIAL FORCE.
- (d) RESOLUTION OF TANGENTIAL FORCE.

FIG. 14.

RESOLUTION OF DISPLACEMENTS AND FORCES.

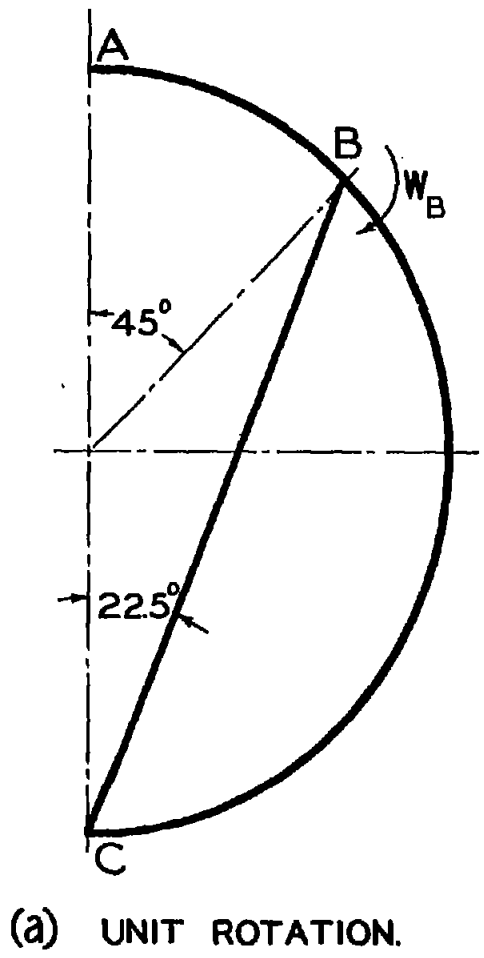

(b) BEAM CONVENTION FOR STRAIGHT BAR.

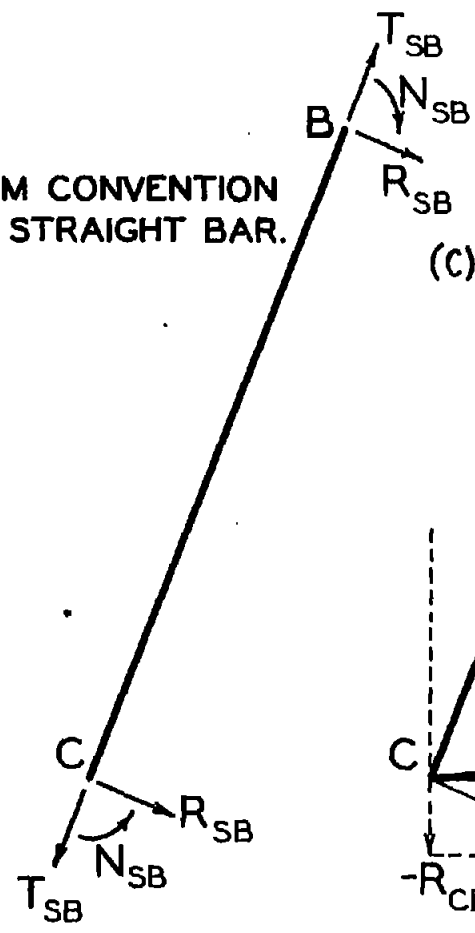

(c) RESOLUTION OF RADIAL FORCE.

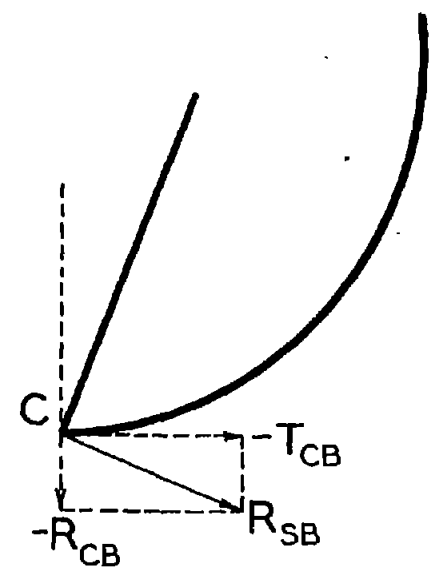

FIG. 15. RESOLUTION OF FORCES AT FIXED END.

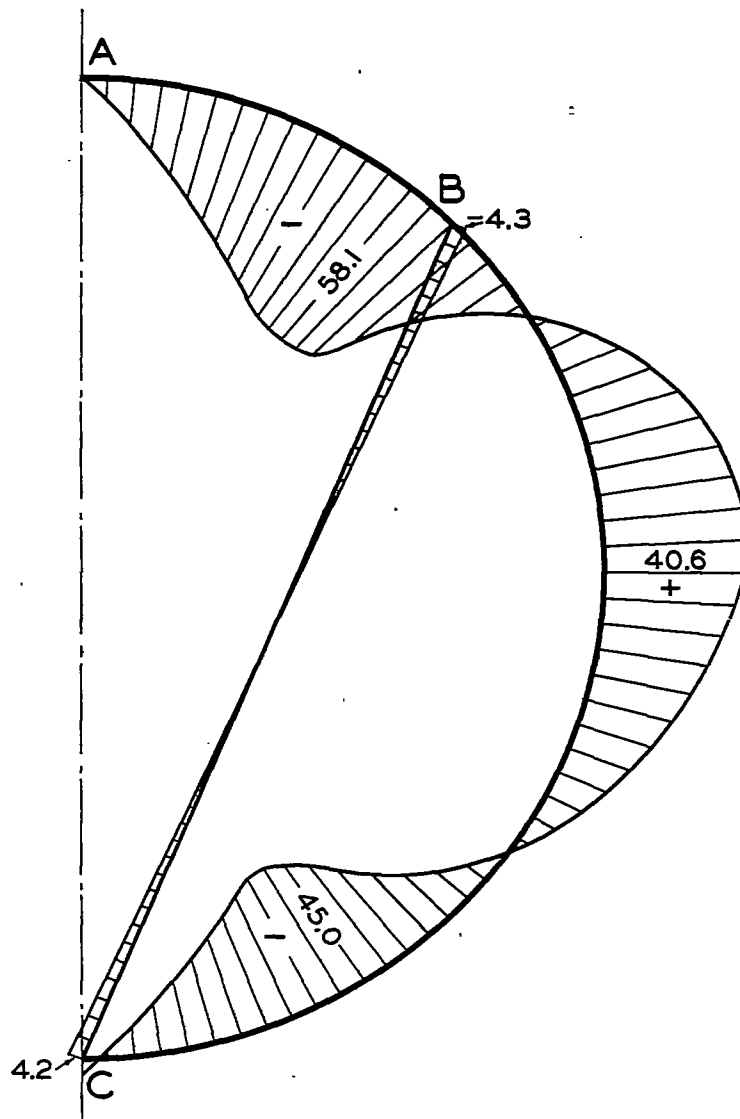

FIG. 16.

BENDING MOMENT DIAGRAM OF BRACED CIRCULAR RING.

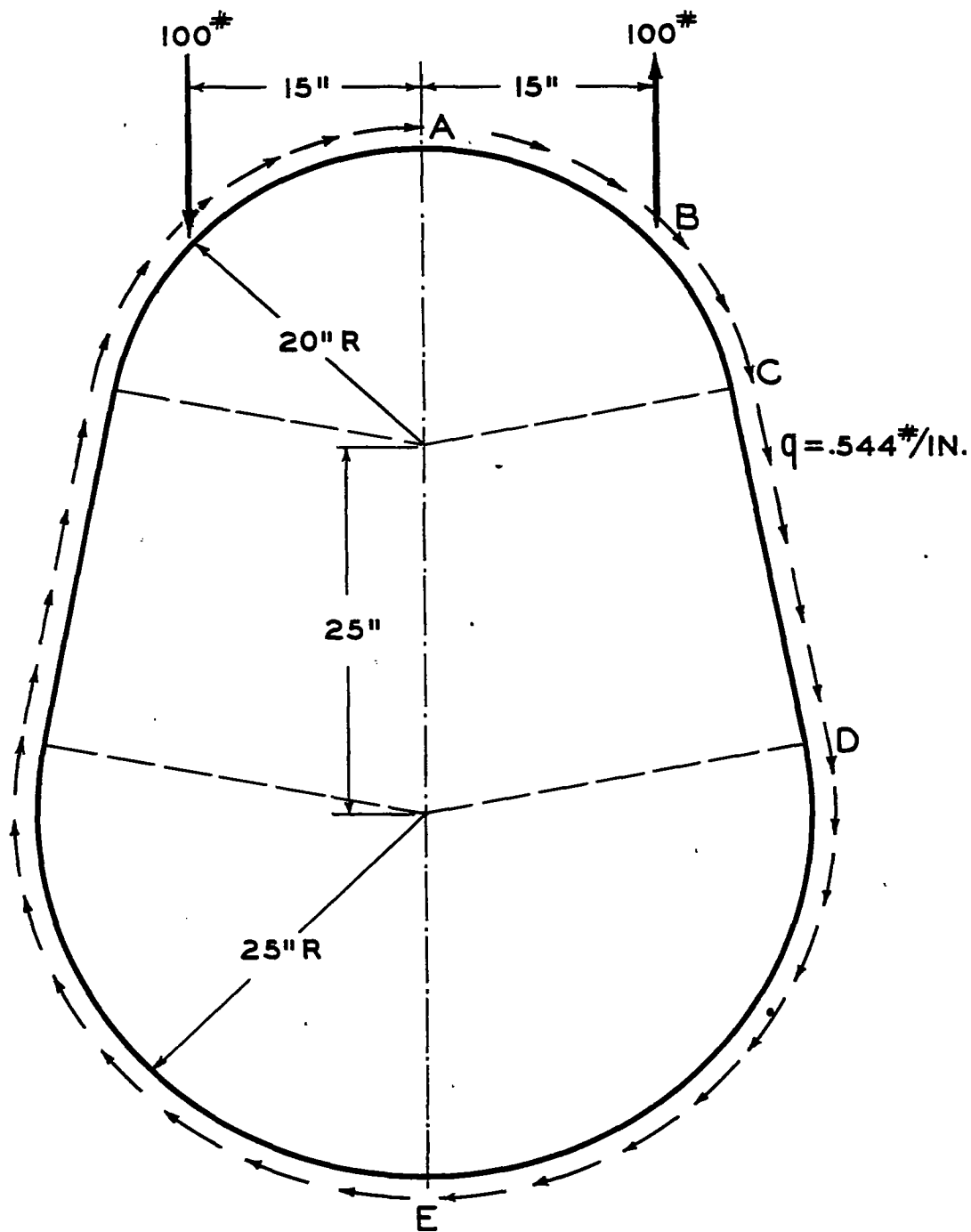

FIG.17 EGG-SHAPED RING WITH ANTISYMMETRIC LOADS.

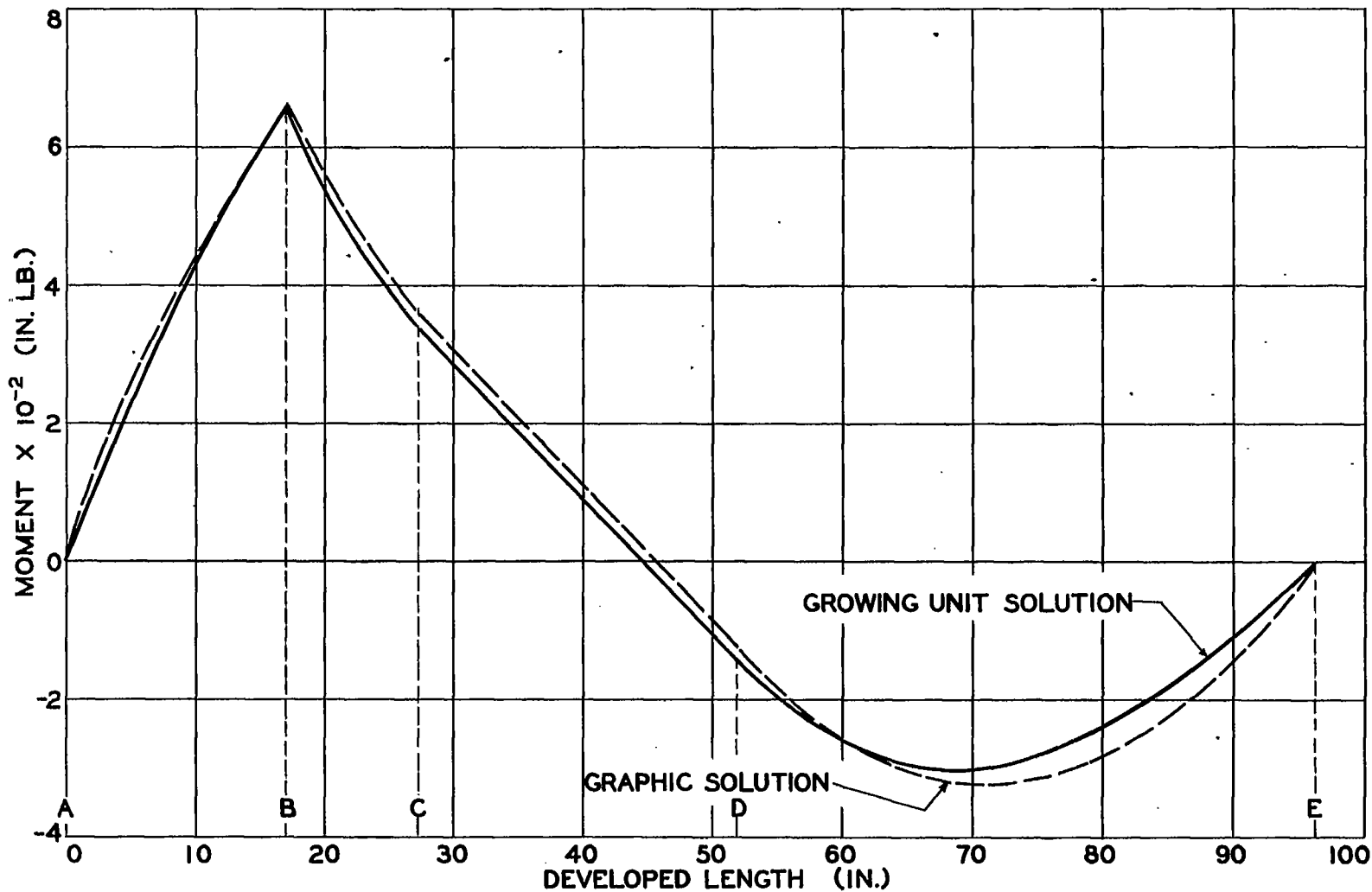

FIG.18 BENDING MOMENT DIAGRAM OF EGG-SHAPED RING IN TORSION.

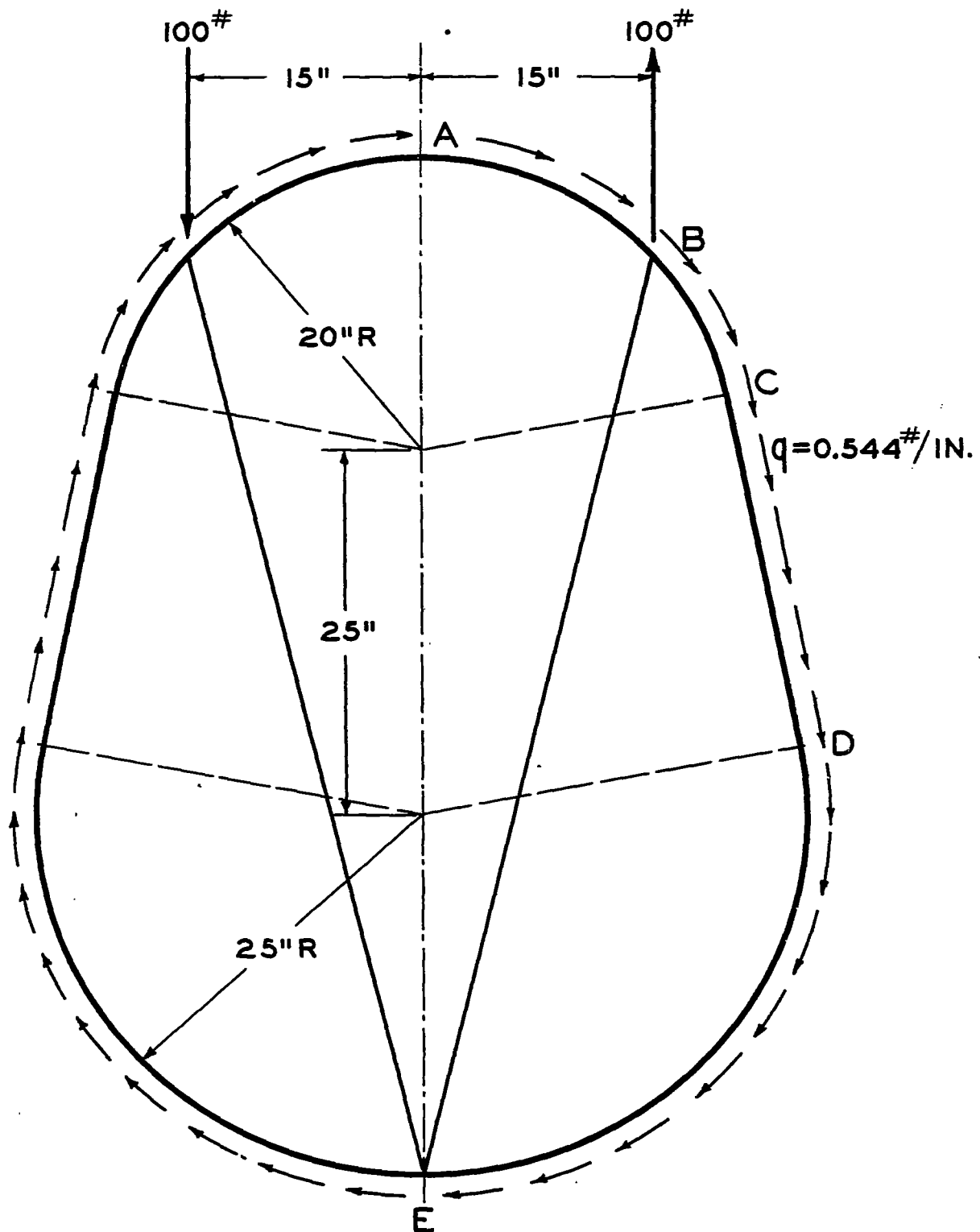

FIG. 19 BRACED EGG-SHAPED RING WITH ANTISYMMETRIC LOADS.

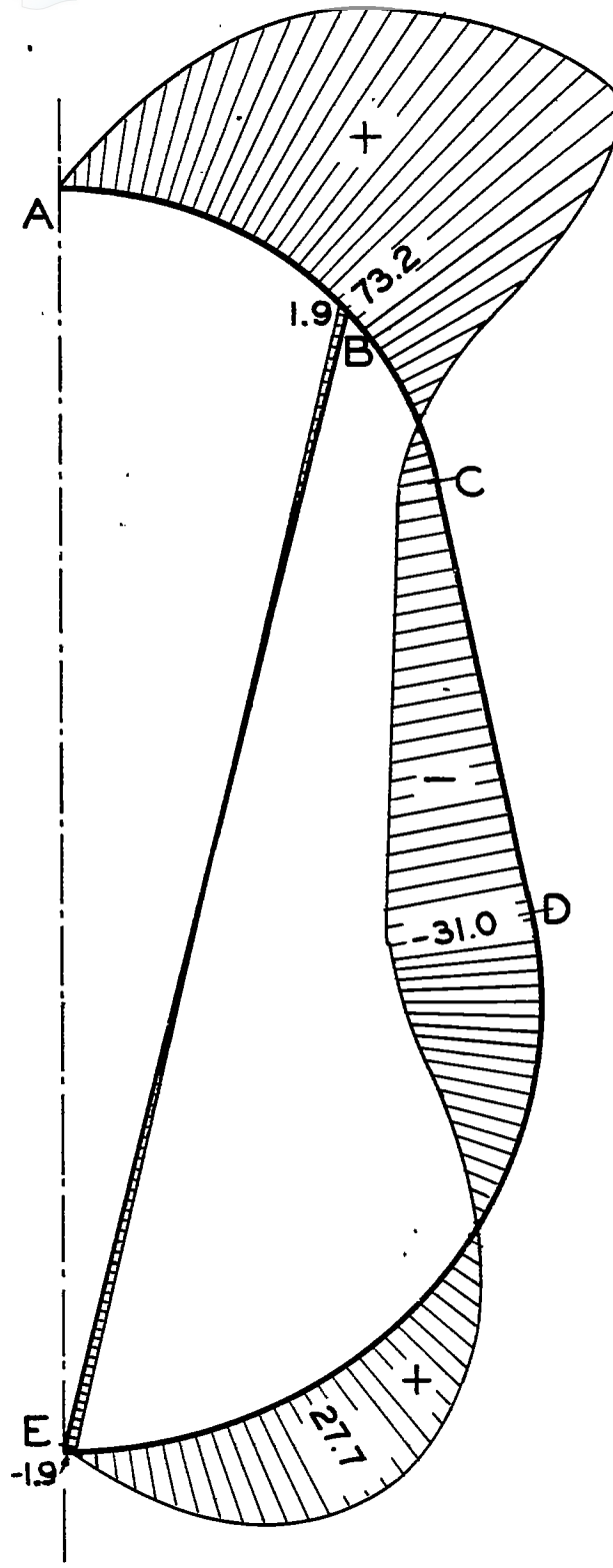

FIG. 20 BENDING MOMENT DIAGRAM OF BRACED EGG-SHAPED RING IN TORSION.