

462

Mr. Lundquist

TECHNICAL NOTES

NATIONAL ADVISORY COMMITTEE FOR AERONAUTICS

Nelson

No. 462

FORMULAS FOR THE STRESS ANALYSIS OF CIRCULAR RINGS

IN A MONOCOQUE FUSELAGE

By Roy A. Miller
Consolidated Aircraft Corporation
and
Karl D. Wood
Cornell University

Washington
June 1933



NATIONAL ADVISORY COMMITTEE FOR AERONAUTICS

TECHNICAL NOTE NO. 462

FORMULAS FOR THE STRESS ANALYSIS OF CIRCULAR RINGS
IN A MONOCOQUE FUSELAGE

By Roy A. Miller and Karl D. Wood

SUMMARY

The formulas given in this report provide a simplified method for the stress analysis of fuselage bulkheads that are approximately circular rings of uniform cross section. Complicated load systems acting on a ring can usually be resolved into simplified load systems; and formulas for moment, axial force, and shear for such simplified load systems are given in this report. Illustrative examples showing the use of this method in practical stress-analysis work are also included.

INTRODUCTION

Many airplanes have fuselages of approximately circular cross section which are built around circular metal bulkhead rings connected by longitudinal metal stringers and covered with a thin sheet-metal skin. A typical airplane of this sort is the Fleetster shown in figure 1. The locations of the main bulkhead rings in the "Fleetster" are shown in figure 1. A sketch of bulkhead ring No. 2 is shown in figure 2; the centroidal axis of the ring is seen to be approximately circular, and the cross section of the ring is uniform for most of its circumference. Under the various conditions of flight and landing, this bulkhead ring is acted on by forces applied at six different points on the circumference of the ring, and sometimes also by distributed tangential forces applied through the skin of the fuselage. Figure 2 shows a typical loading of bulkhead ring No. 2. The most practical solution for the stresses in the ring due to a complicated loading system of this sort is probably obtained by resolving the complicated loading system into a series of simpler loading systems for which the general formulas can be derived. A typical case of such a resolution of forces is shown in

figure 3 where the loading system of figure 2 is resolved into three simplified loading conditions.

The object of this report is to summarize the formulas derived for the simplified loading conditions used in the stress analysis of the "Fleetster" and to show how they may be used in practical stress-analysis work by calculating the stresses in one of the main rings of the "Fleetster" airplane.

Several simplified loading conditions are included in this report in addition to those originally solved by Roy A. Miller (reference 1), and deflection formulas are given for several cases. The derivation of the equations has been omitted from the present report because the equations may be derived by any of several methods, all of which are standard and are given in text books and in various papers on the stresses in statically indeterminate frames. The authors in the derivation of the equations presented in this report used the so-called "method of least work." (See references 1, 2, and 3.)

FORMULAS FOR SIMPLIFIED LOADING CONDITIONS

Each of the eleven simplified loading conditions is designated by a case number. Cases No. I to VI inclusive are identical with the cases of the same number appearing in reference 1. Figure 4 is a free body sketch of a portion of the ring showing the meaning of positive signs for moment M , axial force P , and shear S adopted in reference 1 and continued here. Note that the positive moment is compression on the inside of the ring, positive axial force is tension, and positive shear is as shown in figure 4. If figure 4 is viewed from the left side of the page, the ring may be considered analogous to a beam in which the distance x to any point is measured from the right end of the beam, so that $S = -dM/dx$. This relationship between shear and moment will be observed to exist for all the equations tabulated in this report.

Tables I and II give formulas for M , P , and S for cases I to IV. These formulas are identical with those given in reference 1 except for the simplification of notation shown at the bottom of the tables. Tables III and IV give formulas for cases V to XI in the same manner.

There are really only four essentially different cases considered, namely: I, VI, VIII, and IX. The other cases may be derived from these four cases by substituting special values for the general angles θ and ϕ .

Table V gives formulas for deflection of the horizontal and vertical diameters for rings loaded as in cases I to VII inclusive; positive deflections indicating extension of diameters and negative deflections indicating contractions of diameters as noted at the bottom of Table V. The tabulated formulas for deflection of diameters are of use in connection with the problem of a ring reinforced by a brace across a diameter, and for the general purpose of determining whether the deflections will appear excessive to the occupants of the airplane. Formulas for deflection of any point on the ring relative to some reference point would also be of use but cannot conveniently be tabulated because of their complexity. Such formulas are readily obtainable for each loading case, however, by use of the given moment equations and the general integral equations given in reference 3.

LIMITATION OF THE FORMULAS FOR STRESS AND DEFLECTION

The assumptions involved in the formulas here presented include the usual assumptions for the elastic action of straight beams. An itemized statement of the major assumptions follows:

a) That cross sections of the ring which are plane before bending remain plane after bending; that the elastic limit of the material is not exceeded; that the modulus of elasticity is the same in compression as in tension; and that bending the beam does not appreciably change the shape of its cross section.

b) That the inside and outside radii of the ring are approximately equal to the radius of the centroid of the cross section of the ring.

c) That the cross section of the beam is uniform and the centroidal axis circular.

Assumptions a) are probably true within the limits of experimental measurement for loads that do not produce

permanent deformation of the ring.

Assumption b) involves negligible error in the derivation of the moment equations (see reference 4) but does involve appreciable error in the calculation of bending stress from the moment equations. The error is due to the fact that the bending-stress formula $f = My/I$ is not exactly true for bars initially curved, the stress on the inside of the ring actually being greater, and on the outside less, than that given by $f = My/I$. For a ring of the proportions shown on figure 2 (ratio of centroidal radius to inside radius = 1.07) the calculated bending stress is about 7 percent in error.

Assumption c) involves more or less error when applied to some bulkheads as, for example, the bulkhead shown in figure 2. Experience with other bending problems indicates that thickening a portion of the ring as in figure 2 results in a greater moment at that point than would exist in a uniform ring, and less moment at other points. Stresses calculated at the thick portion will therefore involve errors on the unsafe side, but because of the larger section these stresses will usually not be the critical stresses in design. It is the opinion of the authors that the formulas here tabulated may be safely applied to rings in which the variation in cross section is as great as shown in figure 2 by using R as the centroidal radius which applies to most of the ring and using the actual section at each point for the stress calculations.

APPLICATION OF FORMULAS TO DESIGN OF A MAIN RING OF THE "FLEETSTER" AIRPLANE

Two examples of the use of the formulas in the design of a bulkhead ring follow:

Example 1.- The stresses in bulkhead ring No. 3 will be calculated for an unsymmetrical loading condition. The loads acting on the bulkhead ring, as determined from specifications regarding design loads for low angle of attack with 100 percent load on one wing and 70 percent load on the other, are shown in figure 5. Resolution of this loading system into three simplified loading conditions is shown in figure 6.

Figure 6(a) is case X with $W = 7,912$ lb. and
 $\theta = 135^{\circ}50'$;

Figure 6(b) is case I with $W = 4,392$ lb.,
 $\theta = \pi/2$, and $\phi = 135^{\circ}50'$;

Figure 6(c) is case I with $W = 445$ lb.,
 $\theta = \pi/2$, and $\phi = \pi$.

Points on the ring at which the values of M , P , and S will be found are indicated in figure 5 by A ; B, B' ; C, C' ; D, D' ; E, E' ; F, F' ; and G . The values of M , P , and S at these points are the algebraic sum of the separate values of M , P , and S at the corresponding points for the three simplified loading conditions represented in figure 6. The equations for M/WR , P/W , and S/W for case X may be found in table IV. The equations for M/WR , P/W , and S/W for case I may be found in tables I and II. Knowing the values of W and R in each case, the values of M , P , and S may be found by substituting in the equations the known quantities: W , R , θ, ϕ , x , z , and ω . The value of R to be used in the equations is that of the radius to the centroid of the cross section, namely, $R = 28.7$ inches. For other notations, see Summary of Notation.

The solution of figure 6(a) follows:

$$W_1 = 7,912 \text{ pounds}$$

$$R = 28.7 \text{ inches}$$

$$\theta = 135^{\circ}50' = 2.37 \text{ radians}$$

$$s = \sin \theta = \sin 135^{\circ}50' = 0.697$$

$$c = \cos \theta = \cos 135^{\circ}50' = -0.717$$

$$(sc + \theta) = (0.697)(-0.717) 2.37 = 1.87$$

At the point B: $x = 60^{\circ} = 1.047$ radians

$$z = \sin x = \sin 60^{\circ} = 0.866$$

$$\omega = \cos x = \cos 60^{\circ} = 0.500$$

and the equations for M , P , and S in the range $x = 0$ to $x = \theta$, where point B lies, are from table IV, case X:

6

N.A.C.A. Technical Note No. 462

$$\frac{M}{WR} = -z + \frac{zs}{\pi} + \frac{z}{\pi} (sc + \theta)$$

$$\frac{P}{W} = +z - \frac{zsc}{\pi} - \frac{z\theta}{\pi}$$

$$\frac{S}{W} = +\omega - \frac{s}{\pi} - \frac{\omega sc}{\pi} - \frac{\omega\theta}{\pi}$$

Substituting numerical values in the above equations:

$$M = 7912 \times 28.7 \left[-0.866 + \frac{1.0472 \times 0.697}{\pi} + \frac{0.866}{\pi} \times 1.87 \right]$$

$$= -26,800 \text{ lb.-in.}$$

$$P = 7912 \left[0.866 + \frac{0.866 \times 0.697 \times 0.717}{\pi} - \frac{0.866 \times 2.37}{\pi} \right] = 2770 \text{ lb.}$$

$$S = 7912 \left[0.5 - \frac{0.697}{\pi} + \frac{0.5 \times 0.697 \times 0.717}{\pi} - \frac{0.5 \times 2.37}{\pi} \right] = -155 \text{ lb.}$$

At the point F: $x = 152^{\circ}54' = 2.669$ radians

$$z = \sin x = \sin 152^{\circ}54' = 0.456$$

$$\omega = \cos x = \cos 152^{\circ}54' = -0.890$$

The equations for M, P, and S in the range $x = \theta$ to $x = 2\pi - \Phi$, where point F lies, are from table IV, case X:

$$\frac{M}{WR} = -s + \frac{zs}{\pi} + \frac{z}{\pi} (sc + \theta)$$

$$\frac{P}{W} = -\frac{zsc}{\pi} - \frac{z\theta}{\pi}$$

$$\frac{S}{W} = -\frac{s}{\pi} - \frac{\omega sc}{\pi} - \frac{\omega\theta}{\pi}$$

Substituting numerical values in the above equations:

$$M = 7912 \times 28.7 \left[-0.697 + \frac{2.669 \times 0.697}{\pi} + \frac{0.456}{\pi} \times 1.87 \right]$$

$$= 37,800 \text{ lb.-in.}$$

$$P = 7912 \left[+ \frac{0.456 \times 0.697 \times 0.717}{\pi} - \frac{0.456 \times 2.37}{\pi} \right] = -2150 \text{ lb.}$$

$$S = 7912 \left[- \frac{0.697}{\pi} - \frac{0.890 \times 0.697 \times 0.717}{\pi} + \frac{0.890 \times 2.37}{\pi} \right] = 2445 \text{ lb.}$$

The above values for M, P, and S appear under column (a) in table VI. In a similar manner the values of M, P, and S for the other points in figure 6(a) were found, and are listed in table VI.

The solution of figure 6(b) follows:

$$W_2 = 4,392 \text{ pounds}$$

$$R = 28.7 \text{ inches}$$

$$\theta = \pi/2 = 1.57 \text{ radians}$$

$$s = \sin \theta = \sin \pi/2 = 1.000$$

$$c = \cos \theta = \cos \pi/2 = 0$$

$$(s\theta + c) = (1 \times 1.57 + 0) = 1.57$$

$$\Phi = 135^\circ 50' = 2.37 \text{ radians}$$

$$n = \sin \Phi = \sin 135^\circ 50' = 0.697$$

$$e = \cos \Phi = \cos 135^\circ 50' = -0.717$$

$$(n\Phi + e) = (0.697 \times 2.37 - 0.717) = 0.934$$

$$s^2 = (1)^2 = 1$$

$$n^2 = (0.697)^2 = 0.485$$

$$s^2 - n^2 = (1 - 0.485) = 0.515$$

At the point B: $x = 60^\circ = 1.047 \text{ radians}$

$$z = \sin x = 0.866$$

$$\omega = \cos x = 0.500$$

The equations for M, P, and S in the range $x = 0$ to $x = \theta$, where point B lies, are from table I, case I:

$$\frac{M}{WR} = + \frac{s\theta + c}{\pi} - \frac{n\Phi + e}{\pi} + \frac{\omega}{\pi} (s^2 - n^2) + n - s$$

$$\frac{P}{W} = - \frac{\omega s^2}{\pi} + \frac{\omega n^2}{\pi}$$

$$\frac{S}{W} = + \frac{zs^2}{\pi} - \frac{zn^2}{\pi}$$

Substituting numerical values in the above equations:

$$M = 4392 \times 28.7 \left[+ \frac{1.57}{\pi} - \frac{0.934}{\pi} + \frac{0.5 \times 0.515}{\pi} + 0.697 - 1 \right]$$

$$= -2370 \text{ lb.-in.}$$

$$P = 4392 \left[- \frac{0.5 \times 1}{\pi} + \frac{0.5 \times 0.485}{\pi} \right] = -359 \text{ lb.}$$

$$S = 4392 \left[+ \frac{0.866 \times 1}{\pi} - \frac{0.866 \times 0.485}{\pi} \right] = 622 \text{ lb.}$$

At the point F: $x = 152^\circ 54' = 2.669$ radians

$$z = \sin x = 0.456$$

$$\omega = \cos x = -0.890$$

The equations for M, P, and S in the range $x = \Phi$ to $x = \pi$, where point F now lies, are from table I, case I:

$$\frac{M}{WR} = + \frac{s\theta + c}{\pi} - \frac{n\Phi + e}{\pi} + \frac{\omega}{\pi} (s^2 - n^2)$$

$$\frac{P}{W} = - \frac{\omega s^2}{\pi} + \frac{\omega n^2}{\pi}$$

$$\frac{S}{W} = + \frac{zs^2}{\pi} - \frac{zn^2}{\pi}$$

Substituting numerical values in the above equations:

$$M = 4392 \times 28.7 \left[+ \frac{1.57}{\pi} - \frac{0.934}{\pi} - \frac{0.892 \times 0.515}{\pi} \right] = 7150 \text{ lb.-in.}$$

$$P = 4392 \left[+ \frac{0.890 \times 1}{\pi} - \frac{0.890 \times 0.485}{\pi} \right] = 640 \text{ lb.}$$

$$S = 4392 \left[+ \frac{0.456 \times 1}{\pi} - \frac{0.456 \times 0.485}{\pi} \right] = 328 \text{ lb.}$$

The above values for M, P, and S appear under column (b) in table VI. In a similar manner the values of M, P, and S for the other points in figure 6(b) were found, and are listed in table VI.

The solution of figure 6(c) follows:

$$W_3 = 445 \text{ pounds}$$

$$R = 28.7 \text{ inches}$$

$$\theta = \pi/2 = 1.57$$

$$s = \sin \theta = 1$$

$$c = \cos \theta = 0$$

$$(s\theta + c) = 1.57$$

$$\Phi = \pi = 3.14 \text{ radians}$$

$$n = \sin \Phi = 0$$

$$e = \cos \Phi = -1$$

$$(n\Phi + e) = -1$$

$$s^2 = 1$$

$$n^2 = 0$$

$$(s^2 - n^2) = 1$$

At the point B: $x = 60^\circ = 1.047 \text{ radians}$.

$$z = \sin x = 0.866$$

$$\omega = \cos x = 0.500$$

The equations for M, P, and S in the range $x = 0$ to $x = \theta$, where point B lies, are from table I, case I:

$$\frac{M}{WR} = + \frac{s\theta + c}{\pi} - \frac{n\Phi + e}{\pi} + \frac{\omega}{\pi} (s^2 - n^2) + n - s$$

$$\frac{P}{W} = - \frac{\omega s^2}{\pi} + \frac{\omega n^2}{\pi}$$

$$\frac{S}{W} = + \frac{z s^2}{\pi} - \frac{z n^2}{\pi}$$

Substituting numerical values in the above equations:

$$M = 445 \times 28.7 \left[+ \frac{1.57}{\pi} + \frac{1}{\pi} + \frac{0.5 \times 1}{\pi} + 0 - 1 \right] = - 290 \text{ lb.-in.}$$

$$P = 445 \left[- \frac{0.5 \times 1}{\pi} + \frac{0.5 \times 0}{\pi} \right] = - 71 \text{ lb.}$$

$$S = 445 \left[+ \frac{0.866 \times 1}{\pi} - \frac{0.866 \times 0}{\pi} \right] = 123 \text{ lb.}$$

At the point F: $x = 152^\circ 54' = 2.669$ radians

$$z = \sin x = 0.456$$

$$\omega = \cos x = -0.890$$

The equations for M, P, and S in the range $x = \theta$ to $x = \Phi$, where F now lies, are from table I, case I:

$$\frac{M}{WR} = + \frac{s\theta + c}{\pi} - \frac{n\Phi + e}{\pi} + \frac{\omega}{\pi} (s^2 - n^2) + n - z$$

$$\frac{P}{W} = - \frac{\omega s^2}{\pi} + \frac{\omega n^2}{\pi} + z$$

$$\frac{S}{W} = + \frac{z s^2}{\pi} - \frac{z n^2}{\pi} + \omega$$

Substituting numerical values in the above equations:

$$M = 445 \times 28.7 \left[+ \frac{1.57}{\pi} + \frac{1}{\pi} - \frac{0.890 \times 1}{\pi} + 0 - 0.456 \right] = 1010 \text{ lb.-in.}$$

$$P = 445 \left[+ \frac{0.890 \times 1}{\pi} - \frac{0.890 \times 0}{\pi} + 0.456 \right] = 330 \text{ lb.}$$

$$S = 445 \left[+ \frac{0.456 \times 1}{\pi} - \frac{0.456 \times 0}{\pi} - 0.890 \right] = - 333 \text{ lb.}$$

The above values for M, P, and S appear under column (c) in table VI. In a similar manner the values of M, P, and S for the other points in figure 6(c) were derived.

The algebraic sum of the values of moment, axial force, and shear for the simplified loading conditions shown in figure 6 are given in the last column of table VI. Using these total values, the stresses and margins of safety in the cross section of the ring at the points listed may be computed.

Calculations for the stresses at points B and F on bulkhead ring No. 3 are shown in table VII. Items (1) to (3) in table VII are the values of moment, axial force, and shear just calculated. Items (4) to (12) inclusive are the properties of the cross sections. Items (13) and (14) are the stresses in the inner and outer flange at points B and F, computed from the formula $f = \pm My/I + P/A$ by substituting the values listed in items (1) to (12). A sample calculation for the stress in the outer flange at point B follows:

$$f = + My_1/I + P/A$$

$$f = + \frac{-29460 \times 2.03}{3.49} + \frac{2340}{1.20}$$

$$f = - 17,150 + 1,950 = - 15,200 \text{ lb./sq.in..}$$

The sign of this stress being minus, the stress is compressive in accordance with the notation at the bottom of table VII. If the allowable stress is known, the margin of safety is computed from the usual equation:

$$\text{Margin of safety} = \frac{\text{allowable stress}}{\text{actual stress}} - 1$$

Item (15) is the shearing stress in the web and is calculated from the formula $f_s = SQ/bI$ substituting values from items (3) to (12). A sample calculation for this stress at point B follows:

$$f_s = SQ/bI$$

$$f_s = \frac{590 \times 0.982}{0.064 \times 3.49}$$

$$f_s = 2,600 \text{ lb./sq.in.}$$

Item (16) is the shearing load on the flange rivets and is calculated from the formula $Pr = SQ_{1p}/I$ substituting

values from items (3) to (12). A sample computation for this load at point B follows:

$$P_r = SQ_p/I$$

$$P_r = \frac{590 \times 0.852 \times 0.8125}{3.49}$$

$$P_r = 117 \text{ pounds per rivet.}$$

Example 2.- In this example, moments and forces will be found at various points on the circumference of a ring which is reinforced by a tie rod across its vertical diameter, using the equations for deflection given in table V as a basis for the solution by the method of consistent deflections.

Figure 8 is a free body sketch of such a bulkhead ring acted on by a system of loads determined by the landing load factor for the design. Figure 9 shows the six free body sketches into which figure 8 can be resolved, including a free body sketch of the tie rod acted on by unknown forces F and a corresponding sketch of the ring acted on by equal and opposite forces F. The procedure in solving for F is as follows:

- (1) Compute the deflection d_y of the vertical diameter under the action of the forces shown in figure 9(a), (b), (c), and (d).
- (2) Compute the deflection of the ring (d_{ye0}) and of the cable (d_{yfo}) under the action of a force $F_0 = 1,000$ pounds.
- (3) Compute F from the equation:

$$F = 1,000 \frac{d_y}{d_{ye0} + d_{yfo}}$$

- (4) Compute the moment, axial force, and shear at various points on the ring from the equations of tables I to IV for the five loading cases shown in figure 9, using the value of F just obtained. For the ring use: $R = 28.9$ inches, $E = 10^7$ pounds per square inch, and $I = 3.301 \text{ in.}^4$; for the cable use $A = \text{cross-sectional}$

area = 0.0387 square inch, L = effective length = 50 inches, and $E = 20,400,000$ pounds per square inch.

Proceeding as outlined above, and using the formulas for deflection of vertical diameter d_y , given in table V:

$$(1) \text{ For figure 9(a) } d_{ya} = \frac{WR^3}{EI} \left[+ \frac{2}{\pi} (s-c\theta) + c-1 + \frac{s^2}{2} \right]$$

$$= \frac{4070 \times (28.9)^3}{10^7 \times 3.301} \times 0.137 = 0.407 \text{ in.}$$

$$\text{For figure 9(b) } d_{yb} = \frac{WR^3}{EI} \left[\frac{\pi}{4} - \frac{2}{\pi} \right]$$

$$= \frac{5420 \times (28.9)^3}{10^7 \times 3.301} \times 0.149 = 0.590 \text{ in.}$$

$$\text{For figure 9(c) with } \theta = 41^\circ 45'$$

$$d_{yc} = \frac{WR^3}{EI} \left[- \frac{sc+\theta}{2} - \frac{2}{\pi} (s\theta+c) + s + \frac{\pi}{4} \right]$$

$$= \frac{2200 \times (28.9)^3}{10^7 \times 3.301} \times 0.0542 = 0.087 \text{ in.}$$

$$\text{For figure 9(d) with } \theta = \pi/2, \quad \phi = 136^\circ 15', \text{ and}$$

$$W = -2,670 \text{ lb.}$$

$$d_{yd} = \frac{WR^3}{EI} \left[- \frac{sc+\theta}{2} + \frac{n\phi+\phi}{2} - \frac{2}{\pi} (s\theta+c) + \right.$$

$$\left. + s + \frac{2}{\pi} (n\phi+e) - n \right]$$

$$= \frac{-2670 \times (28.9)^3}{10^7 \times 3.301} \times 0.0493 = -0.096 \text{ in.}$$

Total deflection, figures 9(a) to 9(d) = 0.988 in.

$$(2) \text{ For } F_0 = 1,000 \text{ lb. } d_{ye0} = \frac{WR^3}{EI} \left[\frac{\pi}{2} - \frac{4}{\pi} \right] \text{ with } W = \frac{F_0}{2}$$

$$= \frac{500 \times (28.9)^3}{10^7 \times 3.301} \times 0.298 = 0.109 \text{ in.}$$

14

N.A.C.A. Technical Note No. 462

For $F_0 = 1,000$ lb., from the definition of $E = \frac{F/A}{d/L}$

$$d_{yfo} = \frac{FL}{AE} = \frac{1000 \times 50}{0.0387 \times 20.4 \times 10^6} = 0.063 \text{ in.}$$

$$(3) \text{ For } F = 1,000 \times \frac{d_y}{d_{yeo} + d_{yfo}} = \frac{0.988}{0.109 + 0.063} \times 1,000 = 5,740 \text{ lb.}$$

Referring to figure 8, it may be seen that the effect of the bracing cable is to transfer 5,740 pounds of the 10,840 pounds at point A to point G, thus distributing the load more evenly around the ring.

- (4) Using the value of F just obtained, the moment, axial force, and shear at various points on the ring may be computed from the equations of tables I to IV for the first five loading cases shown in figure 9 by the methods outlined in example 1.

SUMMARY OF NOTATION

- M, bending moment at any cross section of the ring, pound-inches. Positive M causes compression on the inside of the ring.
- P, axial force (tangential) at any cross section of the ring, pounds. Positive P causes tension in the ring.
- S, shear force at any cross section of the ring, pounds. Positive S is as shown in figure 4.
- W, load applied to ring, pounds.
- R, radius to centroid of cross section of the ring, inches.
- E, modulus of elasticity of material of ring, pounds per square inch.
- I, moment of inertia of cross section of the ring, in.⁴.
- θ, ϕ angles specifying location of loads on ring, measured from radius at lowest point on the ring as shown in sketches, radians.

x , angle measured from radius at lowest point on ring to any point on circumference of ring as shown in figure 4, radians.

$s = \sin \theta$
 $c = \cos \theta$
 $n = \sin \phi$
 $e = \cos \phi$
 $z = \sin x$
 $\omega = \cos x$

} abbreviations to simplify
writing of formulas

d_x , change in length of horizontal diameter, inches.

d_y , change in length of vertical diameter, inches.

f , stress, compressive or tensile, lb./sq.in.

f_s , shearing stress, lb./sq.in.

y , distance from neutral axis to outer fibers of cross section, inches.

Q , static moment of half the area of the cross section about the neutral axis, in.³.

REFERENCES

1. Miller, Roy A.: A Solution of the Circular Ring. Airway Age, May 2, 1931, pp. 465-468.
2. Timoshenko, S.: Strength of Materials. D. Van Nostrand Company. 1930 edition, pp. 434-440.
3. Shipman, W. H.: Design of Steam Piping to Care for Expansion. Trans. A.S.M.E., 1929. FSP-51-52.
4. Wahl, A. M.: Stresses and Reactions in Expansion Pipe Bends. Trans. A.S.M.E., 1928. FSP-50-49.

Table I. Moments and Forces. Cases I to IV
 Left Half of Ring

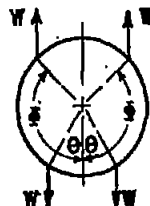
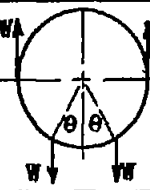
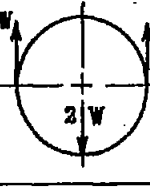
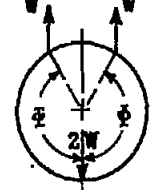
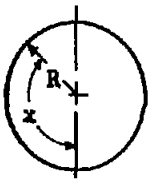
Case No.	Range of $x \rightarrow$	0 to θ			θ to \bar{x}			\bar{x} to π
	Sketch	M/WR	P/W	S/W	M/WR	P/W	S/W	M/WR
I		$+\frac{s\theta + c}{\pi}$ $-\frac{n\bar{x} + e}{\pi}$ $+\frac{\omega}{\pi}(s^2 - n^2)$ $+ n - s$	$-\frac{\omega s^2}{\pi}$ $+\frac{\omega n^2}{\pi}$	$+\frac{zs^2}{\pi}$ $-\frac{zn^2}{\pi}$	$+\frac{s\theta + c}{\pi}$ $-\frac{n\bar{x} + e}{\pi}$ $+\frac{\omega}{\pi}(s^2 - n^2)$ $+ n - z$	$-\frac{\omega s^2}{\pi}$ $+\frac{\omega n^2}{\pi}$ $+ z$	$+\frac{zs^2}{\pi}$ $-\frac{zn^2}{\pi}$ $+ \omega$	$+\frac{s\theta + c}{\pi}$ $-\frac{n\bar{x} + e}{\pi}$ $+\frac{\omega}{\pi}(s^2 - n^2)$
II	$\bar{x} = \pi/2$ 	$+\frac{s\theta + c}{\pi}$ $+\frac{1}{2} - s$ $-\frac{\omega c^2}{\pi}$	$+\frac{\omega c^2}{\pi}$	$-\frac{zc^2}{\pi}$	$+\frac{s\theta + c}{\pi}$ $+\frac{1}{2} - z$ $-\frac{\omega c^2}{\pi}$	$+\frac{\omega c^2}{\pi}$ $+ z$	$-\frac{zc^2}{\pi}$ $+ \omega$	$+\frac{s\theta + c}{\pi}$ $-\frac{1}{2}$ $-\frac{\omega c^2}{\pi}$
III	Range of $x \rightarrow$ 	$x = 0$ to $x = \pi/2$			$x = \pi/2$ to $x = \pi$			Sketch below shows meaning of x and R
		$+\frac{1}{\pi} + \frac{1}{2}$ $-\frac{\omega}{\pi} - z$	$+\frac{\omega}{\pi} + z$	$-\frac{z}{\pi} + \omega$	$+\frac{1}{\pi} - \frac{1}{2}$ $-\frac{\omega}{\pi}$	$+\frac{\omega}{\pi}$	$-\frac{z}{\pi}$	
IV		$x = 0$ to $x = \bar{x}$			$x = \bar{x}$ to $x = \pi$			
		$+\frac{1}{\pi} + n - z$ $-\frac{n\bar{x} + e}{\pi}$ $-\frac{\omega n^2}{\pi}$	$+\frac{\omega n^2}{\pi}$ $+ z$	$-\frac{zn^2}{\pi}$ $+ \omega$	$+\frac{1}{\pi}$ $-\frac{n\bar{x} + e}{\pi}$ $-\frac{\omega n^2}{\pi}$	$+\frac{\omega n^2}{\pi}$	$-\frac{zn^2}{\pi}$	

Notation: $s = \sin\theta$ $n = \sin\bar{x}$ $z = \sin x$
 $c = \cos\theta$ $e = \cos\bar{x}$ $\omega = \cos x$

For signs of M, P, and S see Fig. 4.

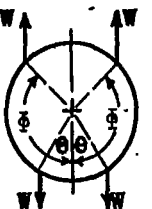
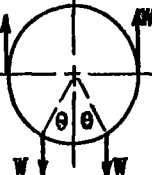
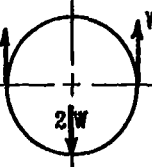
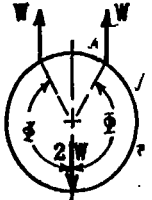
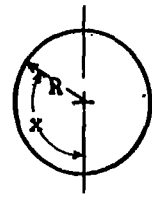
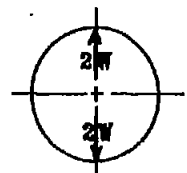
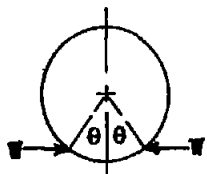

Table II. Moments and Forces. Cases I to IV
 Right Half of Ring

Case No.	Range of $x \rightarrow$	$2\pi - \theta$ to 2π	$2\pi - \theta/2\pi, \pi/2\pi - \bar{x}$		$2\pi - \bar{x}$ to $2\pi - \theta$		π to $2\pi - \bar{x}$	
	Sketch	M/WR	P/W	S/W	M/WR	P/W	S/W	M/WR
I		$+ \frac{s\theta + c}{\pi}$ $- \frac{n\bar{x} + e}{\pi}$ $+ \frac{\omega}{\pi}(s^2 - n^2)$ $+ n - z$	$- \frac{\omega s^2}{\pi}$ $+ \frac{\omega n^2}{\pi}$	$+ \frac{zs^2}{\pi}$ $- \frac{zn^2}{\pi}$	$+ \frac{s\theta + c}{\pi}$ $- \frac{n\bar{x} + e}{\pi}$ $+ \frac{\omega}{\pi}(s^2 - n^2)$ $+ n + z$	$- \frac{\omega s^2}{\pi}$ $+ \frac{\omega n^2}{\pi}$ $- z$	$+ \frac{zs^2}{\pi}$ $- \frac{zn^2}{\pi}$ $- \omega$	$+ \frac{s\theta + c}{\pi}$ $- \frac{n\bar{x} + e}{\pi}$ $+ \frac{\omega}{\pi}(s^2 - n^2)$
II	$\bar{x} = \pi/2$ 	$+ \frac{s\theta + c}{\pi}$ $+ \frac{1}{2} - z$ $- \frac{\omega c^2}{\pi}$	$+ \frac{\omega c^2}{\pi}$	$- \frac{zc^2}{\pi}$	$+ \frac{s\theta + c}{\pi}$ $+ \frac{1}{2} + z$ $- \frac{\omega c^2}{\pi}$	$+ \frac{\omega c^2}{\pi}$ $- z$ $- \omega$	$- \frac{zc^2}{\pi}$ $- \omega$	$+ \frac{s\theta + c}{\pi}$ $- \frac{1}{2}$ $- \frac{\omega c^2}{\pi}$
III	Range of $x \rightarrow$ 	$x = 3\pi/2$ to $x = 2\pi$		$x = \pi$ to $x = 3\pi/2$				
		$+ \frac{1}{\pi} + \frac{1}{2}$ $- \frac{\omega}{\pi} + z$	$+ \frac{\omega}{\pi} - z$	$- \frac{z}{\pi} - \omega$	$+ \frac{1}{\pi} - \frac{1}{2}$ $- \frac{\omega}{\pi}$	$+ \frac{\omega}{\pi}$ $- \frac{z}{\pi}$		Sketch below shows meaning of x and R
IV		$x = 2\pi - \bar{x}$ to $x = 2\pi$		$x = \pi$ to $x = 2\pi - \bar{x}$				
		$+ \frac{1}{\pi} + n + z$ $- \frac{n\bar{x} + e}{\pi}$ $- \frac{\omega n^2}{\pi}$	$+ \frac{\omega n^2}{\pi}$ $- z$	$- \frac{zn^2}{\pi}$ $- \omega$	$+ \frac{1}{\pi}$ $- \frac{n\bar{x} + e}{\pi}$ $- \frac{\omega n^2}{\pi}$	$+ \frac{\omega n^2}{\pi}$ $- \frac{zn^2}{\pi}$		

Notation: $s = \sin\theta$ $n = \sin\bar{x}$ $z = \sin x$
 $c = \cos\theta$ $e = \cos\bar{x}$ $\omega = \cos x$

For signs of M, P, and S, see Fig. 4.

Table III. Moments and Forces. Cases V to VIII

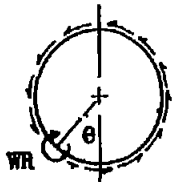
Case No.	Range of $x \rightarrow$	M/WR	P/W	S/W	M/WR	P/W	S/W
		$x = 0$ to $x = \pi$			$x = \pi$ to $x = 2\pi$		
V		$+\frac{2}{\pi} - z$	$+ z$	$+ \omega$	$+\frac{2}{\pi} + z$	$- z$	$- \omega$
	Range of $x \rightarrow$	$x = -\theta$ to $x = +\theta$			$x = \theta$ to $x = 2\pi - \theta$		
VI		$+\frac{c\theta - \theta}{\pi}$ $+\frac{W}{\pi}(sc - \theta)$ $+ \omega - c$	$+\frac{W}{\pi}(\theta - sc)$ $- \omega$	$+\frac{1}{\pi}(sc - \theta)$ $+ z$	$+\frac{c\theta - \theta}{\pi}$ $+\frac{W}{\pi}(sc - \theta)$	$+\frac{W}{\pi}(\theta - sc)$ $+\frac{1}{\pi}(sc - \theta)$	
VII		$-\frac{2\omega s}{\pi}$ $-\frac{\theta}{\pi} + 1$	$+\frac{2\omega s}{\pi}$	$-\frac{2zs}{\pi}$	$-\frac{2\omega s}{\pi}$ $-\frac{\theta}{\pi}$	$+\frac{2\omega s}{\pi}$	$-\frac{2zs}{\pi}$
	Range of $x \rightarrow$	$x = 0$ to $x = \theta$			$x = \theta$ to $x = 2\pi$		
VIII		$+\frac{z\theta - \omega s}{\pi}$ $+\frac{z}{2\pi} - \frac{\theta}{2} + \frac{1}{2}$	$-\frac{z\theta - \omega s}{\pi}$	$-\frac{\omega c + zs}{\pi}$ $-\frac{1}{2\pi}$	$+\frac{z\theta - \omega s}{\pi}$ $+\frac{z}{2\pi} - \frac{\theta}{2} - \frac{1}{2}$	$-\frac{\omega c + zs}{\pi}$	$-\frac{1}{2\pi}$

Notation: $s = \sin \theta$ $z = \sin x$
 $c = \cos \theta$ $\omega = \cos x$

For signs of M, P, and S,
 see Fig. 4.

Table IV. Moments and Forces. Cases IX to XI

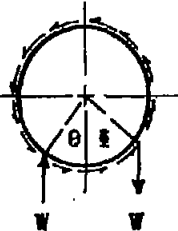
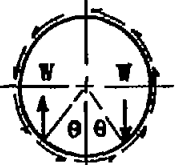
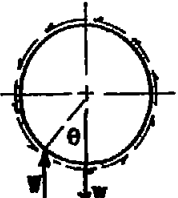
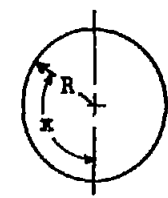
Case No.	Range of $x \rightarrow$ Sketch	0 to θ			0 to θ , $2\pi - \bar{x}$ to 2π			$x = \theta$ to $x = 2\pi - \bar{x}$			$2\pi - \bar{x}$ to 2π
		M/WR	P/W	S/W	M/WR	P/W	S/W	M/WR	P/W	S/W	M/WR
IX		$+\frac{s-n}{2} - \frac{s\theta + c}{2n}$	$+\frac{\omega s^2}{2n}$	$+\omega - \frac{s+n}{2n}$	$-\frac{s+n}{2} - \frac{s\theta + c}{2n}$	$+\frac{\omega s^2}{2n}$	$-\frac{s+n}{2n}$	$-\frac{3n+s}{2} - \frac{s\theta + c}{2n}$	$+\frac{\omega s^2}{2n}$	$-\frac{s+n}{2n}$	$-\frac{3n+s}{2} - \frac{s\theta + c}{2n}$
		$+\frac{n\bar{x} + e}{2n} - z$	$-\frac{\omega n^2}{2n}$	$+\omega - \frac{s+n}{2n}$	$+\frac{n\bar{x} + e}{2n}$	$-\frac{\omega n^2}{2n}$	$-\frac{s+n}{2n}$	$+\frac{n\bar{x} + e}{2n} - z$	$-\frac{\omega n^2}{2n}$	$-\frac{s+n}{2n}$	$+\frac{n\bar{x} + e}{2n} - z$
X		$-\frac{\omega}{2n}(s^2 - n^2)$	$+\frac{z}{2n}(sc + \theta)$	$+\frac{z}{2n}(ne + \bar{x})$	$+\frac{z}{2n}(sc + \theta)$	$-\frac{z\theta}{2n}$	$-\frac{\omega}{2n}(s^2 - n^2)$	$-\frac{z\theta}{2n}$	$-\frac{z\theta}{2n}$	$-\frac{\omega}{2n}(s^2 - n^2)$	
		$+\frac{z}{2n}(sc + \theta)$	$-\frac{z\theta}{2n}$	$-\frac{\omega}{2n}(s^2 - n^2)$	$+\frac{z}{2n}(sc + \theta)$	$-\frac{z\theta}{2n}$	$-\frac{\omega}{2n}(s^2 - n^2)$	$+\frac{z}{2n}(sc + \theta)$	$-\frac{z\theta}{2n}$	$-\frac{\omega}{2n}(s^2 - n^2)$	
XI		$+\frac{z}{2n}(ne + \bar{x})$	$+\frac{z}{2n}(s+n)$	$-\frac{z\theta}{2n}$	$+\frac{z}{2n}(ne + \bar{x})$	$-\frac{z\theta}{2n}$	$+\frac{z}{2n}(ne + \bar{x})$	$-\frac{z\theta}{2n}$	$-\frac{z\theta}{2n}$	$+\frac{z}{2n}(ne + \bar{x})$	
		$+\frac{z}{2n}(s+n)$	$-\frac{z\theta}{2n}$	$-\frac{\omega}{2n}$	$+\frac{z}{2n}(s+n)$	$-\frac{z\theta}{2n}$	$-\frac{\omega}{2n}$	$+\frac{z}{2n}(s+n)$	$-\frac{z\theta}{2n}$	$-\frac{\omega}{2n}$	
	Range of $x \rightarrow$	$x = 0$ to $x = \theta$			$x = \theta$ to $x = 2\pi$						
		$+\frac{s}{2} - \frac{s\theta + c}{2n}$	$+\frac{z}{2n}$	$+\omega - \frac{s}{2n}$	$-\frac{s}{2} - \frac{s\theta + c}{2n}$	$+\frac{\omega s^2}{2n}$	$-\frac{s}{2n}$				
		$+\frac{1}{2n} - \frac{\omega s^2}{2n}$	$+\frac{\omega s^2}{2n}$	$-\frac{z\theta}{2n}$	$+\frac{1}{2n} - \frac{\omega s^2}{2n}$	$-\frac{z\theta}{2n}$	$-\frac{\omega s^2}{2n}$				
		$+\frac{z\bar{x}}{2n} - z$	$-\frac{z\theta}{2n}$	$-\frac{\omega s^2}{2n}$	$+\frac{z\bar{x}}{2n}$	$-\frac{z\theta}{2n}$	$-\frac{z\theta}{2n}$				
		$+\frac{z}{2n}(sc + \theta)$	$-\frac{z\theta}{2n}$	$-\frac{\omega}{2n}$	$+\frac{z}{2n}(sc + \theta)$	$-\frac{z\theta}{2n}$	$-\frac{\omega}{2n}$				

Notation: $s = \sin\theta$ $n = \sin\bar{x}$ $z = \sin x$
 $c = \cos\theta$ $e = \cos\bar{x}$ $\omega = \cos x$

For signs of M, P, and S,
 see Fig. 4.

Table V. Deflections. Cases I to VII.

Case No.	Sketch	Horizontal Diameter	Vertical Diameter
		$\frac{EI}{WR^3} d_x$	$\frac{EI}{WR^3} d_y$
I		$+ \frac{s^2 + n^2}{2} + 1 - 2n$ $- \frac{2}{\pi}(s\theta + c)$ $+ \frac{2}{\pi}(n\bar{s} + e)$	$- \frac{sc + \theta}{2} + \frac{ne + \bar{s}}{2}$ $- \frac{2}{\pi}(s\theta + c) + s$ $+ \frac{2}{\pi}(n\bar{s} + e) - n$
II		$+ \frac{s^2 + 1}{2}$ $- \frac{2}{\pi}(s\theta + c)$	$- \frac{sc + \theta}{2}$ $- \frac{2}{\pi}(s\theta + c)$ $+ s + \frac{\pi}{4}$
III		$\frac{1}{2} - \frac{2}{\pi} = -0.137$	$\frac{\pi}{4} - \frac{2}{\pi} = +0.149$
IV		$+ \frac{n^2 + 2}{2}$ $+ \frac{2}{\pi}(n\bar{s} + e)$ $- \frac{2}{\pi} - 2n$	$+ \frac{ne + \bar{s}}{2}$ $+ \frac{2}{\pi}(n\bar{s} + e)$ $- \frac{2}{\pi} - n$
V		$1 - \frac{4}{\pi} = -0.274$	$\frac{\pi}{2} - \frac{4}{\pi} = +0.298$
VI		$+ \frac{2}{\pi}(s - c\theta)$ $+ \frac{sc - \theta}{2}$	$+ \frac{2}{\pi}(s - c\theta)$ $+ c - 1 + \frac{\pi}{2}$
VII		$\frac{2\theta}{\pi} - s$	$\frac{2\theta}{\pi} + c - 1$

* * *
 These expressions are not valid when theta is less than pi/4.

* * *
 Not valid for theta greater than pi/4

$s = \sin \theta, \quad c = \cos \theta; \quad n = \sin \bar{\theta}, \quad e = \cos \bar{\theta}.$
 $+ = \text{extension}, \quad - = \text{contraction}.$

Table VI. Moments, Axial Force, and Shear at Various Points in Bulkhead Ring No. 3 for the Loading Shown in Figs. 6 and 7.

Point on ring	Loading Case (sketch at right)			
	(a)	(b)	(c)	Total

Moment

A	0	+ 7,950	+ 1,750	+ 9,700
B	-26,800	- 2,370	- 290	-29,460
B'	+26,800	- 2,370	- 290	+24,140
C	-12,800	-12,700	- 2,320	-27,820
C'	+12,800	-12,700	- 2,320	- 2,220
D	+10,200	-12,300	- 2,940	- 5,040
D'	-10,200	-12,300	- 2,940	-25,440
E	+55,400	+10,700	- 1,360	+64,740
E'	-55,400	+10,700	- 1,360	-46,060
F	+37,800	+ 7,150	+ 1,010	+45,960
F'	-37,800	+ 7,150	+ 1,010	-29,640
G	0	+ 4,890	+ 6,390	+11,280

Axial Force

A	0	- 718	- 142	- 860
B	+ 2,770	- 359	- 71	+ 2,340
B'	- 2,770	- 359	- 71	- 3,200
C	+ 3,200	0	0	+ 3,200
C'	+ 3,200	+ 4,390	+ 450	+ 8,040
C''	- 3,200	+ 4,390	+ 450	+ 1,640
D	- 3,200	0	0	- 3,200
D'	+ 3,010	+ 4,380	+ 470	+ 7,860
D''	- 3,010	+ 4,380	+ 470	+ 1,840
E	+ 2,235	+ 3,580	+ 415	+ 6,230
E'	- 3,280	+ 515	+ 415	- 2,350
E''	+ 3,280	+ 515	+ 415	+ 4,210
E'''	- 2,235	+ 3,580	+ 415	+ 1,760
F	- 2,150	+ 640	+ 330	- 1,180
F'	+ 2,150	+ 640	+ 330	+ 3,120
G	0	+ 718	+ 142	+ 860

Shear

A	+ 1,450	0	0	+ 1,450
B	- 155	+ 622	+ 123	+ 590
B'	- 155	- 622	- 123	- 900
C	- 1,760	+ 718	+ 142	- 900
C'	- 1,760	- 718	- 142	- 2,620
D	- 2,840	- 812	- 18	- 3,670
D'	- 2,840	+ 812	+ 18	- 2,010
D''	- 4,050	- 2,650	- 220	- 6,920
E	+ 1,630	+ 500	- 220	+ 1,910
E'	+ 1,630	- 500	+ 220	+ 1,350
E''	- 4,050	+ 2,650	+ 220	- 1,180
F	+ 2,445	+ 328	- 333	+ 2,440
F'	+ 2,445	- 328	+ 333	+ 2,450
G	+ 2,965	0	- 445	+ 2,520
G'	+ 2,965	0	+ 445	+ 3,410

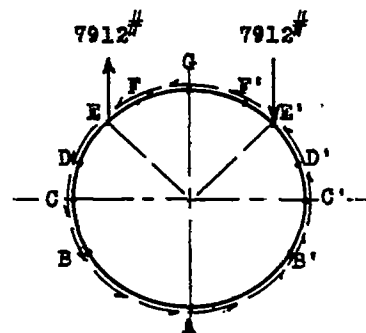

(a)

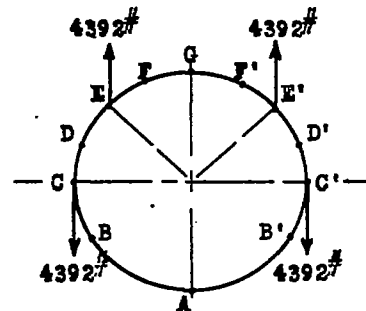

(b)

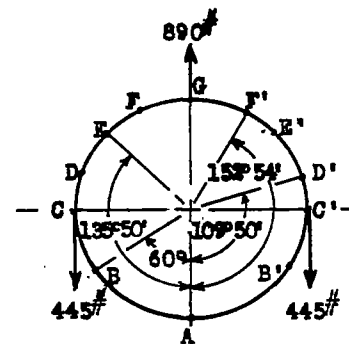

(c)

TABLE VII. CALCULATION OF STRESSES IN BULKHEAD RING
 No. 3 at points B and F

No.	Item	Symbol	Point B	Point F
1	Bending moment, lb.-in.	M	-29,460	+45,960
2	Axial force, lb.	P	+ 2,340	--1,180
3	Shear, lb.	S	+ 590	+ 2,440
Properties of sections (Fig. 7)				
4	Depth of section, in.	d	4.04	4.04
5	Area, sq.in.	A	1.20	1.20
6	Moment of inertia, in. ⁴	I	3.49	3.49
7	Total static moment, in. ³	Q ₂	.982	.982
8	Static moment of flange, in. ³	Q ₁	.852	.852
9	Dist. to extr. outer fiber, in.	y ₁	2.03	2.03
10	Dist. to extr. inner fiber, in.	y ₂	2.01	2.01
11	Web thickness, in.	b	.064	.064
12	Flange rivet spacing, in.	p	.813	.813
Stresses				
13	Stress in lb./sq.in. Inner flange	$f = -My_2/I + P/A$	+18,950	-27,464
14	Stress in lb./sq.in. Outer flange	$f = +My_1/I + P/A$	-15,200	+25,736
15	Shearing, lb./sq.in. Stress in web	$f_s = SQ/bI$	2,600	10,720
16	Shear load on Flange rivets, lb.	$P_r = SQ_1p/I$	117	484

Note: Tensile stress is +
 Compressive stress is -

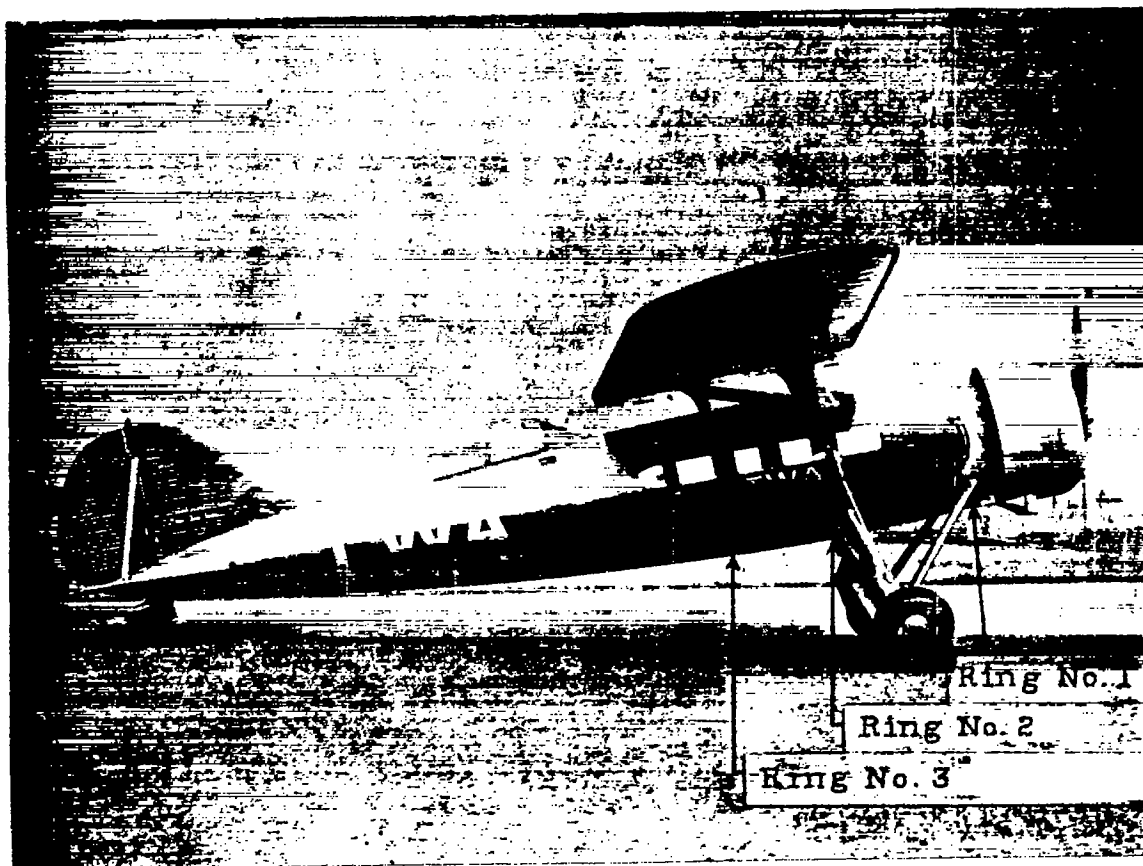

Figure 1.- "Fleetster" airplane. Main bulkhead rings are at points where wing and landing gear join the fuselage, and are indicated by arrows.

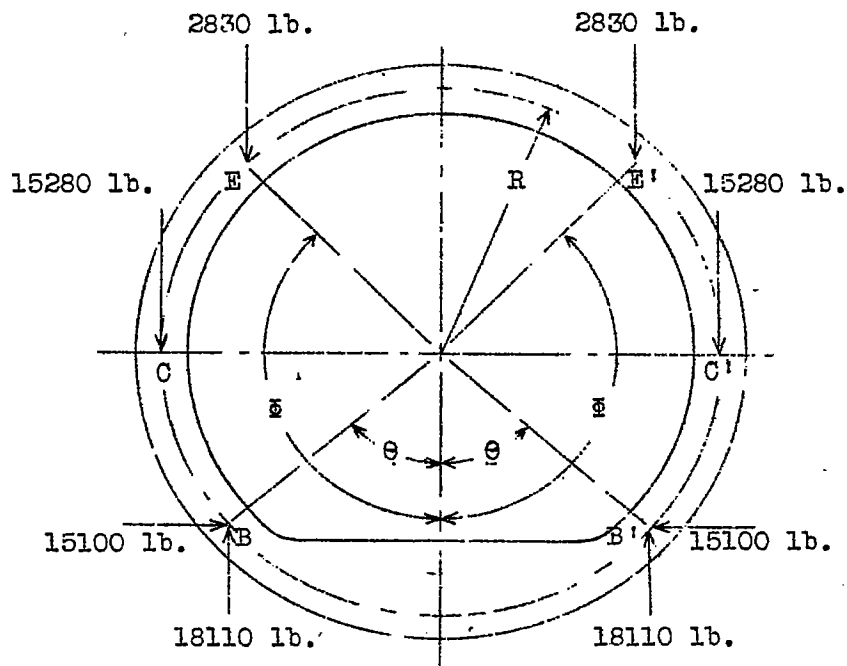

Figure 2.- Bulkhead ring No. 2 of "Fleetster" airplane with symmetrical loading.

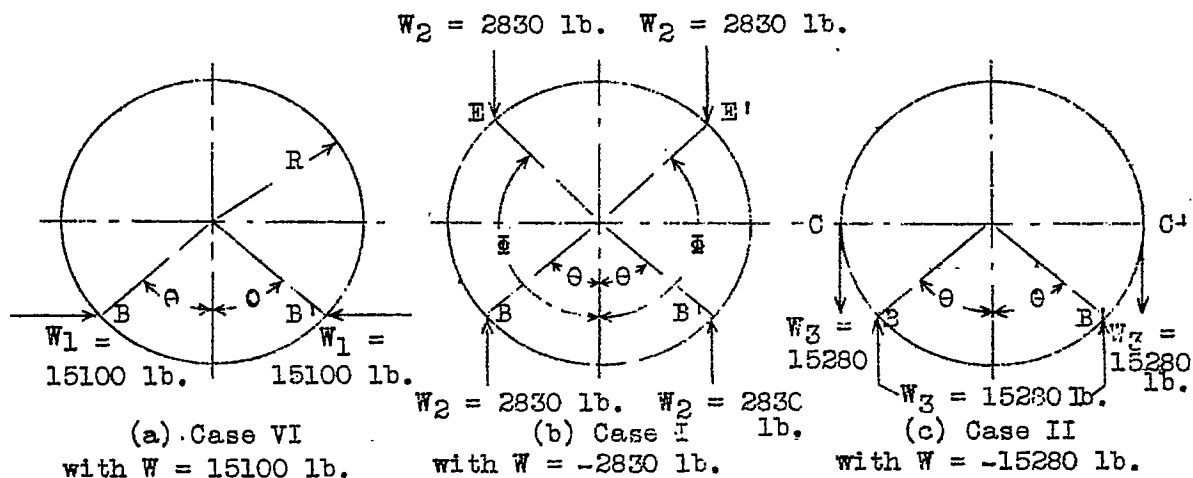

Figure 3.- Loading shown in figure 2 resolved into simplified loading conditions.

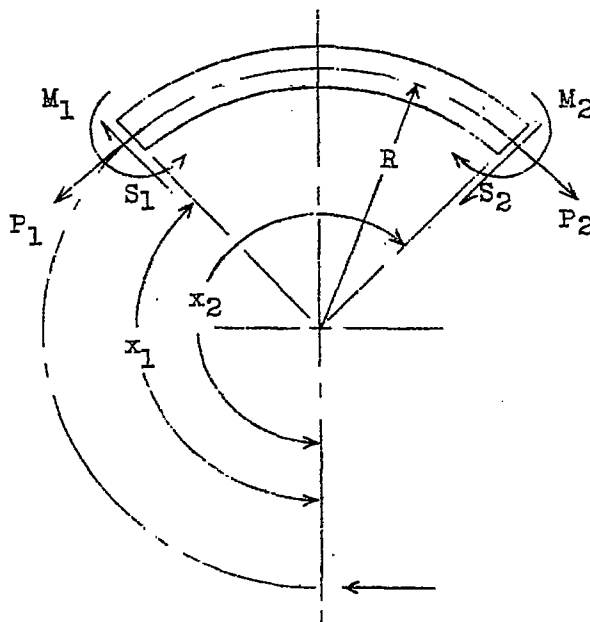

Figure 4.- Sketch showing directions of moment, shear, axial force, and angular location assumed as positive in this report.

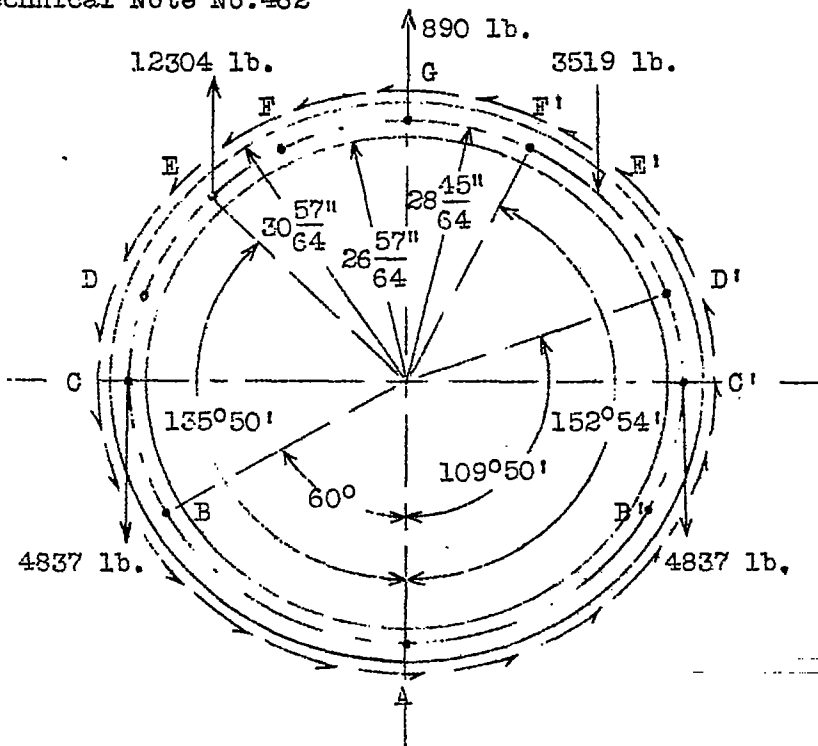

Figure 5.- Bulkhead ring No. 3 of "Fleetster" airplane with unsymmetrical loading.

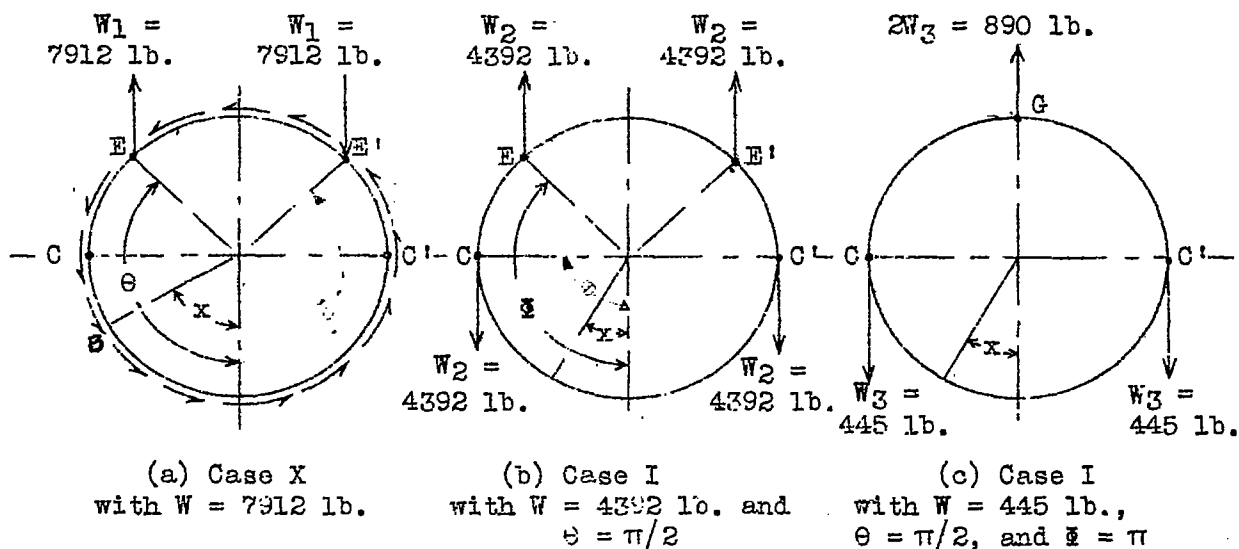

Figure 6.- Loading shown in figure 5 resolved into simplified loading conditions.

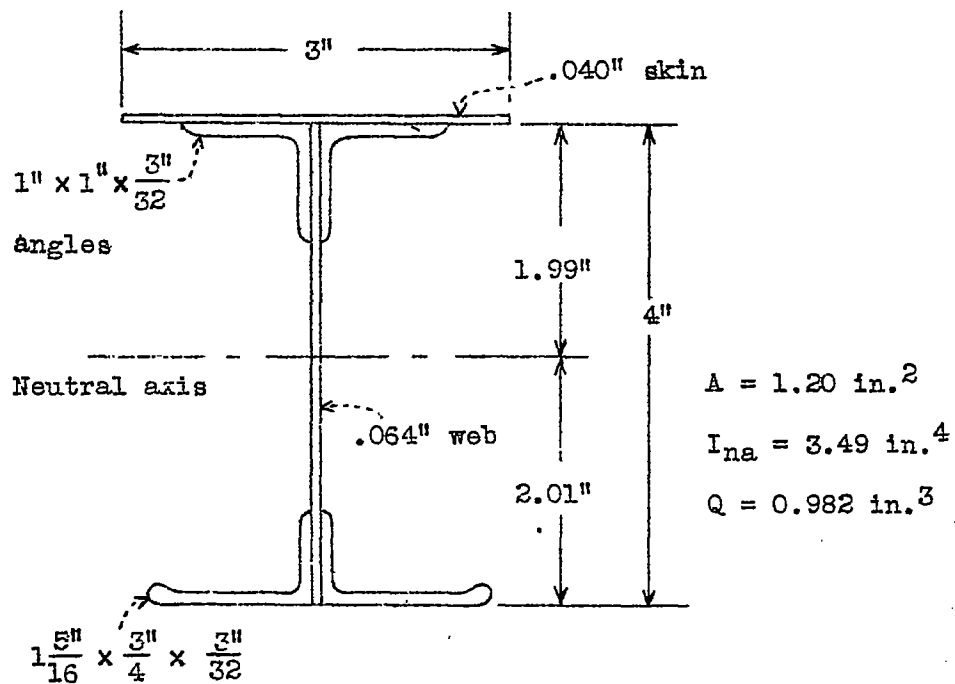

Figure 7.- Section of bulkhead ring No. 3
of "Fleetster" airplane.

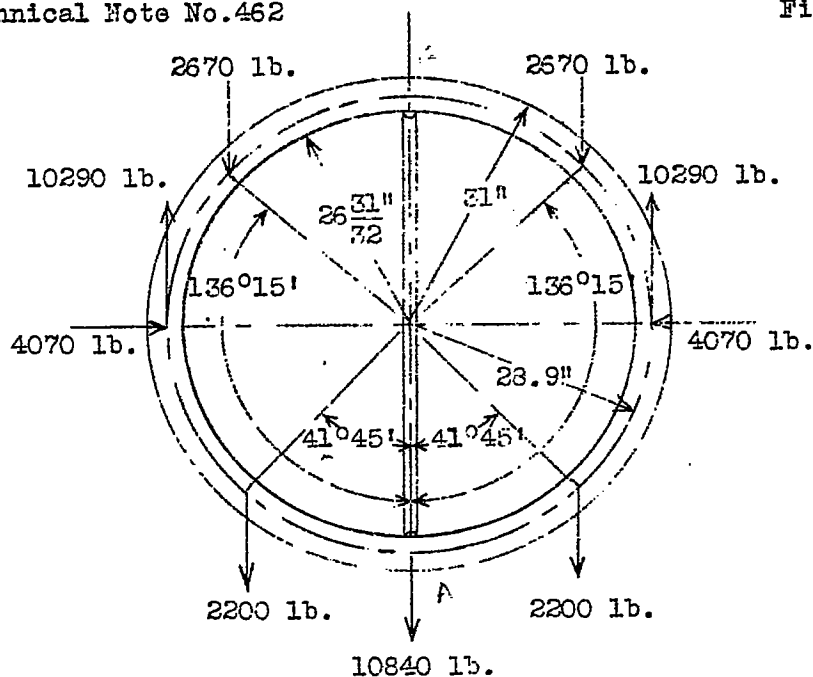

Figure 8.- Reinforced bulkhead ring with loads.

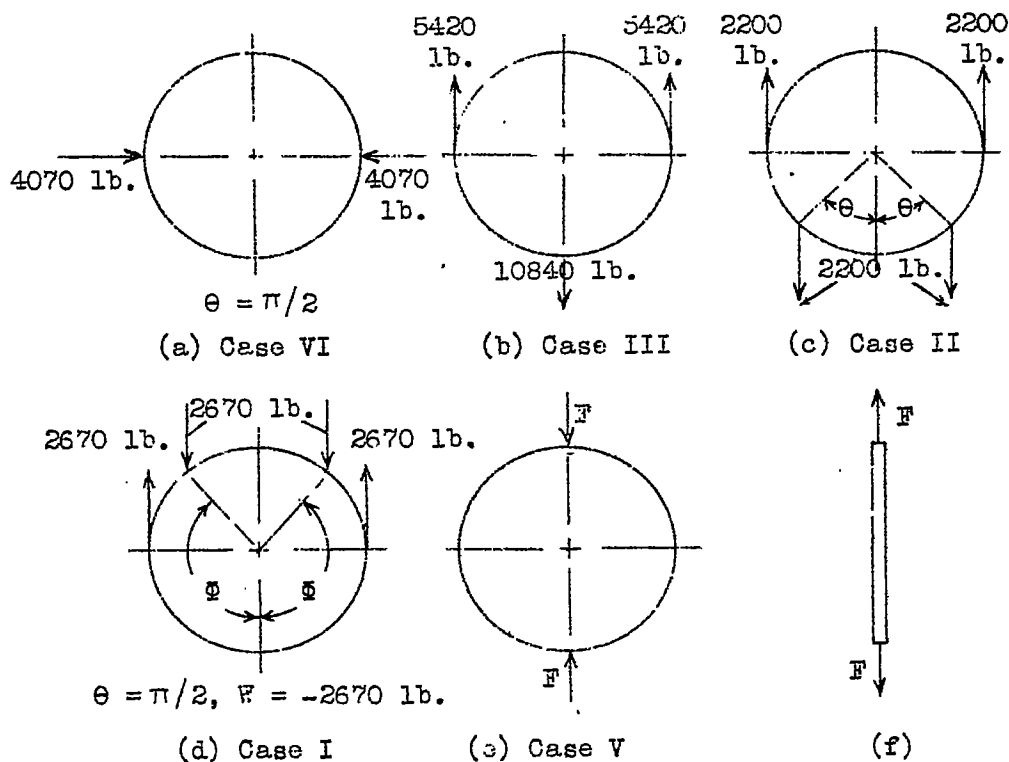

Figure 9.- Loading shown in figure 8 resolved into simplified loading conditions.