

NACA TN 1928

NATIONAL ADVISORY COMMITTEE FOR AERONAUTICS

TECHNICAL NOTE 1928

CRITICAL COMBINATIONS OF SHEAR AND DIRECT AXIAL
STRESS FOR CURVED RECTANGULAR PANELS

By Murry Schildcrout and Manuel Stein

Langley Aeronautical Laboratory
Langley Air Force Base, Va.

PROPERTY OF
ENGINEERING LIBRARY



Washington

August 1949

298



[The main body of the document contains extremely faint and illegible text, likely bleed-through from the reverse side of the page. The text is too light to transcribe accurately.]

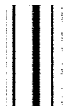

NATIONAL ADVISORY COMMITTEE FOR AERONAUTICS

TECHNICAL NOTE 1928

CRITICAL COMBINATIONS OF SHEAR AND DIRECT AXIAL

STRESS FOR CURVED RECTANGULAR PANELS

By Murry Schildcrout and Manuel Stein

SUMMARY

A solution is presented for the problem of the buckling of curved rectangular panels subjected to combined shear and direct axial stress. Charts giving theoretical critical combinations of shear and direct axial stress are presented for panels having five different length-width ratios.

Because the actual critical compressive stress of rectangular panels having substantial curvature is known to be much lower than the theoretical value, a semiempirical method of analysis of curved panels subjected to combined shear and direct axial stress is presented for use in design.

INTRODUCTION

An investigation was made to determine the combinations of shear and direct axial stress that cause simply supported curved rectangular panels to buckle. Because panels having substantial curvature are known to buckle in compression at a stress well below the theoretical value, the solution must be at least partly empirical. In order to eliminate the necessity for an extensive test program, a theoretical solution to the problem is presented and is modified for use in design. The modifications to the theoretical interaction curves are based upon results of tests on the buckling of curved rectangular panels under combined shear and axial compression and incorporate results for curved panels subjected to shear alone (reference 1) and axial compression alone (references 2 and 3). The resulting empirical interaction curves are expected to give a good approximation to the actual critical combinations of shear and direct axial stress.

SYMBOLS

a	axial or circumferential dimension of panel, whichever is larger
b	axial or circumferential dimension of panel, whichever is smaller
m,n,p,q	integers
r	radius of curvature of panel
t	thickness of panel
w	displacement of point on shell median surface in radial direction; positive outward
x	axial coordinate of panel
y	circumferential coordinate of panel
D	flexural stiffness of panel per unit length $\left(\frac{Et^3}{12(1-\mu^2)}\right)$
E	Young's modulus of elasticity
Z	curvature parameter $\left(\frac{b^2}{rt}\sqrt{1-\mu^2}\right)$
a_{mn}, a_{pq}	coefficients of terms in deflection functions
k_s	critical-shear-stress coefficient $\left(\frac{\tau tb^2}{\pi^2 D}\right)$
k_x	critical-axial-stress coefficient $\left(\frac{\sigma_x tb^2}{\pi^2 D}\right)$
$(R_s)_{th}$	theoretical shear-stress ratio (ratio of shear stress present to theoretical critical shear stress in absence of other stresses)
$(R_s)_{exp}$	experimental shear-stress ratio (ratio of shear stress present to experimental critical shear stress in absence of other stresses)

$(R_x)_{th}$ theoretical direct-axial-stress ratio (ratio of direct axial stress present to theoretical direct axial stress in absence of other stresses)

$(R_x)_{exp}$ experimental direct-axial-stress ratio (ratio of direct axial stress present to experimental critical direct axial stress in absence of other stresses)

$$\beta = \frac{a}{b}$$

μ Poisson's ratio

τ critical shear stress

σ_x critical axial stress

$$\nabla^4 = \frac{\partial^4}{\partial x^4} + 2 \frac{\partial^4}{\partial x^2 \partial y^2} + \frac{\partial^4}{\partial y^4}$$

∇^{-4} inverse of ∇^4 defined by $\nabla^{-4}(\nabla^4 w) = w$

RESULTS AND DISCUSSION

Theoretical Solution

The combinations of shear and axial stress that cause rectangular curved panels (fig. 1) to buckle may be obtained from the equations

$$\tau = \frac{k_g \pi^2 D}{b^2 t}$$

and

$$\sigma_x = \frac{k_x \pi^2 D}{b^2 t}$$

when the stress coefficients k_g and k_x are known. The theoretical combinations of stress coefficients for simply supported curved rectangular panels having different ratios of circumferential to axial dimension are given in figure 2. These combinations of stress were obtained from the solution presented in the appendix, based upon the small deflection theory of elastic stability of curved

plates. Each part of figure 2 presents results for panels having a constant ratio of circumferential to axial dimension but various values of the curvature parameter Z .

Figure 2 indicates that, irrespective of the length-width ratio of the panel, the theoretical interaction curves approach those for a cylinder as the value of Z increases. The value of Z at which this correlation between the cylinder and rectangular panel becomes close increases as the ratio of circumferential to axial dimension of the panel decreases. The critical compressive stress of rectangular panels is very nearly equal to that of cylinders even at low values of Z , whereas the critical shear stress differs greatly at low values of Z ; therefore, a good indication of the point at which the interaction curve for a panel is approximated very closely by that for a cylinder is the value of Z at which the respective critical shear stresses are nearly equal. These values of Z may be obtained for simply supported panels having various length-width ratios from figure 3, which is taken from reference 1. At sufficiently high values of Z , as in the case of a cylinder (see reference 4), the theoretical interaction curves in stress-ratio form may therefore be approximated in the compression range by a straight line from $(R_x)_{th} = 1$ to $(R_s)_{th} = 1$ and in the beginning of the tension range by a straight line of slope -0.8 passing through $(R_s)_{th} = 1$. The critical-axial-stress and critical-shear-stress coefficients are obtained, respectively, by multiplying the stress ratio $(R_x)_{th}$ by the theoretical critical stresses for axial compression alone and the corresponding stress ratio $(R_s)_{th}$ by the theoretical critical stresses for shear alone. These theoretical critical stresses may be obtained from figures 4 to 7, which are taken from references 1 to 3.

Although a theoretical solution is given only for simply supported panels, the conclusions drawn as to the shape of the interaction curves may be extended to clamped panels, because clamped panels of appreciable curvature buckle at stresses equal to or only slightly higher than simply supported panels. (See figs. 4 to 7.)

The interaction data computed for simply supported panels are given in table 1.

Empirical Interaction Curves

Curved rectangular panels are known to buckle in compression at stresses well below the theoretical values, whereas they buckle in shear at stresses close to the theoretical values; therefore, the theoretical solution for the critical combinations of compression and

shear must be modified so that it may be used for the design of panels subjected to combined shear and axial compression. Empirical interaction curves for long plates with transverse curvature and for cylinders (references 3 and 4) indicate that the design curves in the compression range for rectangular panels with substantial curvature would be of the form

$$(R_s)_{th}^2 + (R_x)_{exp} = 1 \quad (1)$$

where the denominators of the stress ratios $(R_s)_{th}$ and $(R_x)_{exp}$ are, respectively, the theoretical critical stress of the panel in shear alone and the experimentally determined critical stress of the panel in axial compression alone. Equation (1) should be conservative for all panels regardless of the length-width ratio and should become more conservative as the ratio of the axial to the circumferential dimension increases.

The critical shear stress to be used as the denominator of the stress ratio $(R_s)_{th}$ may be obtained from figures 6 and 7. In order to eliminate the need for interpolation for the critical shear stress of curved rectangular panels of any length-width ratio, the results of figure 6 for panels with simply supported edges are replotted in terms of other parameters in figure 8. The ordinate in figure 8 is the increase in the critical-shear-stress coefficient Δk_s over the flat-plate value and the abscissa is a function of the curvature parameter Z and the length-width ratio of the panel β . In using this figure β should be taken as equal to 1 whenever the circumferential dimension is equal to or greater than the axial dimension. The value of the shear-stress coefficient for a panel is determined by adding the value of Δk_s found from figure 8 to the flat-plate value given approximately by the equation

$$k_s = 5.35 + \frac{4}{\beta^2}$$

as obtained from reference 5 or more accurately by

$$k_s = 5.34 + \frac{4}{\beta^{7/4}}$$

where β is a/b . In a similar way a curve may be obtained for panels with clamped edges by replotting the results of figure 7 in terms of the same parameters as figure 8.

The critical compressive stress to be used as the denominator of the stress ratio $(R_x)_{exp}$ may be approximated by the design curves of figures 4 and 5 for cylinders and long curved plates, respectively.

At very low values of Z ($Z < 10$), panels buckle in compression at a stress close to the theoretical value and the theoretical interaction curves may be used for design.

Rectangular curved panels subjected to combined shear and tension may be expected to buckle at stresses that agree closely with the theoretically predicted values because tension tends to minimize initial imperfections. The theoretical interaction curve should therefore be used for this range.

In connection with the present paper a set of 25 panels that had been previously buckled were subjected to a combination of shear and compression. (The previous results were presented in reference 6.) Because most or perhaps all of these panels had large initial eccentricities an inordinate amount of scatter in the various test results was found. Comparisons could be made, however, between the different critical combinations of stress on each panel. These comparisons are shown in stress-ratio form in figure 9, in which the stress ratios are based on the experimental stress for buckling under either compression or shear alone. These comparisons confirm the shape of the curve represented by equation (1) in the compression range.

CONCLUDING REMARKS

The theoretical solution for the buckling of rectangular curved panels in combined shear and direct axial stress indicates that the behavior of a panel is similar to that of a cylinder when the curvature parameter is sufficiently high, irrespective of the length-width ratio of the panel. For lower values of the curvature parameter theoretical interaction curves for panels of five different length-width ratios are presented that give either the shear or direct axial stress required for buckling when a given amount of the other stress is present.

Because a panel having substantial curvature buckles in compression alone at a stress well below the theoretical critical stress, the theoretical results for the critical combinations of stress are modified in the compression range for the purposes of design.

Langley Aeronautical Laboratory
National Advisory Committee for Aeronautics
Langley Air Force Base, Va., June 23, 1949

APPENDIX

THEORETICAL SOLUTION

The problem of the buckling of a simply supported rectangular curved panel under combined shear and direct axial stress (fig. 1) is solved in a manner similar to the one used for the buckling of a panel under shear alone. (See the appendix of reference 1.)

The equation of equilibrium of reference 1 is modified to introduce direct axial stress and becomes

$$D\nabla^4 w + \frac{Et}{r^2} \nabla^4 \frac{\partial^4 w}{\partial x^4} + 2\tau t \frac{\partial^2 w}{\partial x \partial y} + \sigma_x t \frac{\partial^2 w}{\partial x^2} = 0 \quad (A1)$$

where x and y are, respectively, the axial and circumferential coordinates.

The problem is solved by use of the Galerkin method as outlined in references 7 and 8. As in the case of shear alone, the following series expansion is used for w

$$w = \sum_{m=1}^{\infty} \sum_{n=1}^{\infty} a_{mn} \sin \frac{m\pi x}{a} \sin \frac{n\pi y}{b} \quad (A2)$$

which imposes the boundary conditions of simple support.

Division of equation (A1) by D gives

$$\nabla^4 w + \frac{12Z^2}{b^4} \nabla^4 \frac{\partial^4 w}{\partial x^4} + \frac{2k_y \pi^2}{b^2} \frac{\partial^2 w}{\partial x \partial y} + \frac{k_x \pi^2}{b^2} \frac{\partial^2 w}{\partial x^2} = 0$$

The equation of equilibrium may be represented by

$$Qw = 0$$

where Q is the operator defined by

$$Q = \nabla^4 + \frac{12Z^2}{b^4} \nabla^4 \frac{\partial^4}{\partial x^4} + \frac{2k_s \pi^2}{b^2} \frac{\partial^2}{\partial x \partial y} + \frac{k_x \pi^2}{b^2} \frac{\partial^2}{\partial x^2}$$

According to the Galerkin method the coefficients are chosen to satisfy the equations

$$\int_0^a \int_0^b \sin \frac{p\pi x}{a} \sin \frac{q\pi y}{b} Qw \, dx \, dy = 0 \quad (A3)$$

$$(p = 1, 2, \dots; q = 1, 2, \dots)$$

When the expressions for Q and w are substituted in equation (A3) and the indicated operations are performed, the following set of algebraic equations results:

$$a_{pq} \left[(p^2 + q^2 \beta^2)^2 + \frac{12}{\pi^4} \frac{Z^2 \beta^4 p^4}{(p^2 + q^2 \beta^2)^2} - k_x \beta^2 p^2 \right] + \frac{32\beta^3 k_s}{\pi^2} \sum_{m=1}^{\infty} \sum_{n=1}^{\infty} a_{mn} \frac{mnpq}{(m^2 - p^2)(q^2 - n^2)} = 0$$

$$(p = 1, 2, \dots; q = 1, 2, \dots)$$

where the summation includes only those values of m and n for which $m \pm p$ and $n \pm q$ are odd. The condition for a nonvanishing solution of these equations is the vanishing of the determinant of the coefficients of the unknown values of a_{pq} . This infinite determinant may be factored into two infinite subdeterminants, one for $p \pm q$ even and the other for $p \pm q$ odd. The vanishing of these subdeterminants leads to determinantal equations similar to equations (9) and (10) of reference 1, except that M_{pq} is now defined by

$$M_{pq} = \frac{\pi^2}{32\beta^3 k_B} \left[(p^2 + q^2\beta^2)^2 + \frac{12}{\pi^4} \frac{Z^2\beta^4 p^4}{(p^2 + q^2\beta^2)^2} - k_X \beta^2 p^2 \right]$$

These determinants give the combinations of stresses that cause buckling of curved plates with various ratios of axial to circumferential dimension. The solution to the determinant where $p \pm q$ is even corresponds to a buckle pattern that is symmetrical about the center of the panel, and the solution where $p \pm q$ is odd corresponds to a buckle pattern antisymmetrical about the center of the panel.

By use of a finite determinant including the rows and columns corresponding to the most important terms (usually ten are sufficient) in the expansion for w (equation (A2)), the two determinantal equations were solved by a matrix iteration method (reference 9) for the lowest combinations of k_X and k_B that satisfied the equations. The present solution was found by maintaining k_X at an assumed constant value and solving for the lowest value of k_B that satisfies each of the two equations. The lower of the two k_B values found by solving both determinantal equations with a constant k_X value is the critical-shear-stress coefficient for the values of β , Z , and k_X under consideration. This procedure is repeated for a given value of β and Z , and several constant values of k_X are used until enough points are obtained to draw an interaction curve. The computed interaction data are presented in table 1.

Figure 2 gives the interaction curves obtained from the lower combinations of interaction data presented in table 1. The discontinuities in the curves of these figures are caused by a change of buckle pattern from symmetrical to antisymmetrical.

In the previous discussion a and b are, respectively, the axial and circumferential dimensions of the panel. For the purposes of comparison with the cylinder, the definitions of a and b were reversed in table 1 and in the figures. No changes were made in the definitions of k_X , k_B , Z , and β .

REFERENCES

1. Batdorf, S. B., Stein, Manuel, and Schildcrout, Murry: Critical Shear Stress of Curved Rectangular Panels. NACA TN 1348, 1947.
2. Batdorf, S. B., Schildcrout, Murry, and Stein, Manuel: Critical Stress of Thin-Walled Cylinders in Axial Compression. NACA Rep. 887, 1947.
3. Batdorf, S. B., Schildcrout, Murry, and Stein, Manuel: Critical Combinations of Shear and Longitudinal Direct Stress for Long Plates with Transverse Curvature. NACA TN 1347, 1947.
4. Batdorf, S. B., Stein, Manuel, and Schildcrout, Murry: Critical Combinations of Torsion and Direct Axial Stress for Thin-Walled Cylinders. NACA TN 1345, 1947.
5. Timoshenko, S.: Theory of Elastic Stability. McGraw-Hill Book Co., Inc., 1936, p. 361.
6. Rafel, Norman, and Sandlin, Charles W., Jr.: Effect of Normal Pressure on the Critical Compressive and Shear Stress of Curved Sheet. NACA ARR L5B10, 1945.
7. Batdorf, S. B.: A Simplified Method of Elastic-Stability Analysis for Thin Cylindrical Shells. NACA Rep. 874, 1947.
8. Duncan, W. J.: The Principles of the Galerkin Method. R. & M. No. 1848, British A.R.C., 1938.
9. Batdorf, S. B., and Stein, Manuel: Critical Combinations of Shear and Direct Stress for Simply Supported Rectangular Flat Plates. NACA TN 1223, 1947.

TABLE 1
 THEORETICAL COMBINATIONS OF SHEAR-STRESS AND AXIAL-STRESS COEFFICIENTS
 FOR SIMPLY SUPPORTED RECTANGULAR CURVED PANELS

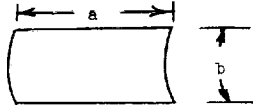

β $(\frac{a}{b})$	Z $(\frac{b^2}{rt} \sqrt{1-\mu^2})$	k_x $(\frac{\sigma_x t b^2}{D r^2})$	k_B $(\frac{r t b^2}{D r^2})$	
			Even determinant	Odd determinant
1	1	4.03	0	-----
		3.6	3.130	7.704
		2	6.652	-----
		0	9.44	11.59
		-3.6	13.13	14.50
	10	7.08	0	-----
		6	4.431	6.766
		4	7.447	-----
		0	11.65	12.77
		-6	16.60	16.93
	30	21.08	0	-----
		18	5.603	6.846
10		-----	11.95	
0		18.57	17.59	
-18		28.07	26.53	
100	70.3	0	-----	
	60	10.07	7.433	
	40	-----	16.97	
	0	34.65	33.55	
	-60	54.45	55.68	
1.5	1	4.37	-----	0
		4	2.795	2.334
		2	5.376	5.990
		0	7.124	8.025
		-4	10.04	11.14
	10	7.17	-----	0
		6	3.419	3.882
		4	5.522	-----
		0	8.550	9.750
		-6	12.26	13.53
	30	21.16	-----	0
		18	4.899	5.208
10		9.338	-----	
0		14.30	15.38	
-18		22.16	22.34	
100	70.2	-----	0	
	60	8.503	7.476	
	40	-----	14.61	
	0	30.54	27.15	
	-60	46.78	44.24	
2	1	4.03	-----	0
		3.6	3.520	2.168
		2	5.119	-----
		0	6.618	6.652
		-3.6	8.755	9.285
	10	7.08	-----	0
		6	3.402	3.158
		4	5.146	-----
		0	7.645	8.433
		-6	10.78	11.96
	100	70.3	0	-----
		60	7.642	8.358
40		14.82	16.21	
0		26.96	26.19	
-60		42.02	39.72	

TABLE 1.- Concluded

THEORETICAL COMBINATIONS OF SHEAR-STRESS AND AXIAL-STRESS

COEFFICIENTS - Concluded

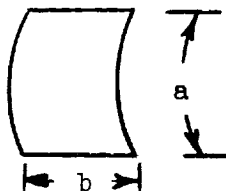

β $\left(\frac{a}{b}\right)$	z $\left(\frac{b^2}{rt}\sqrt{1-\mu^2}\right)$	k_x $\left(\frac{\sigma_x t b^2}{D\pi^2}\right)$	k_s $\left(\frac{rtb^2}{D\pi^2}\right)$	
			Even determinant	Odd determinant
1.5	1	2.15	0	-----
		1.8	3.006	6.257
		1	5.314	-----
		0	7.373	7.994
		-1.8	9.588	9.621
	10	7.42	-----	0
		6	4.448	3.530
		4	-----	5.822
		0	10.38	9.490
30	-6	14.58	13.90	
	21.07	0	-----	
	18	4.574	3.694	
	10	9.840	-----	
2	1	0	15.23	15.51
		-18	24.09	24.70
		1.57	0	-----
		1.3	3.293	5.064
.8		5.053	5.806	
10	0	0	6.676	6.611
		-1.3	8.374	8.070
		7.08	-----	0
		6	3.738	2.288
		4	-----	4.953
2	0	0	8.983	8.948
		-6	13.18	13.59

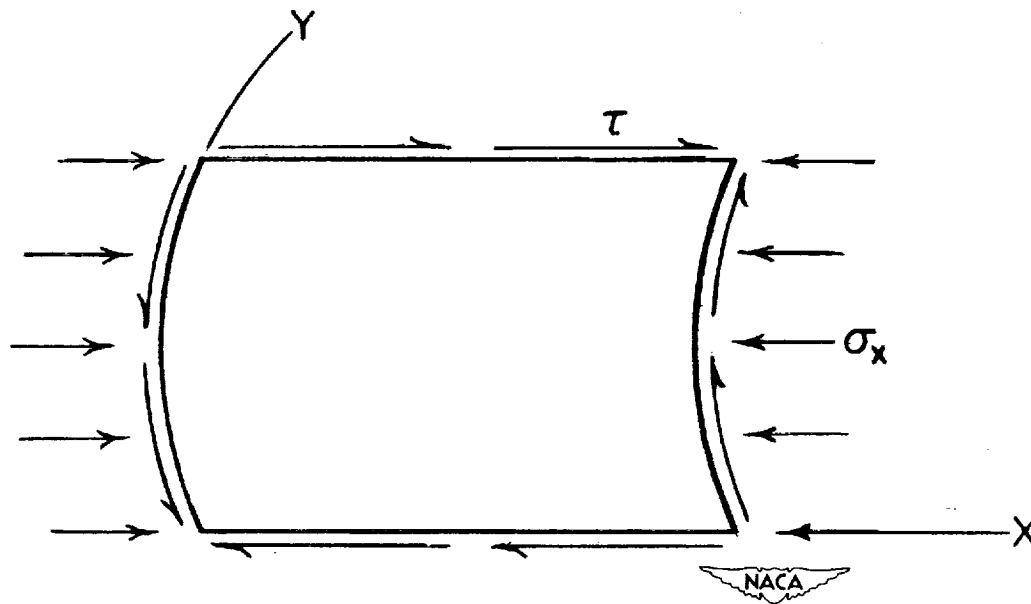
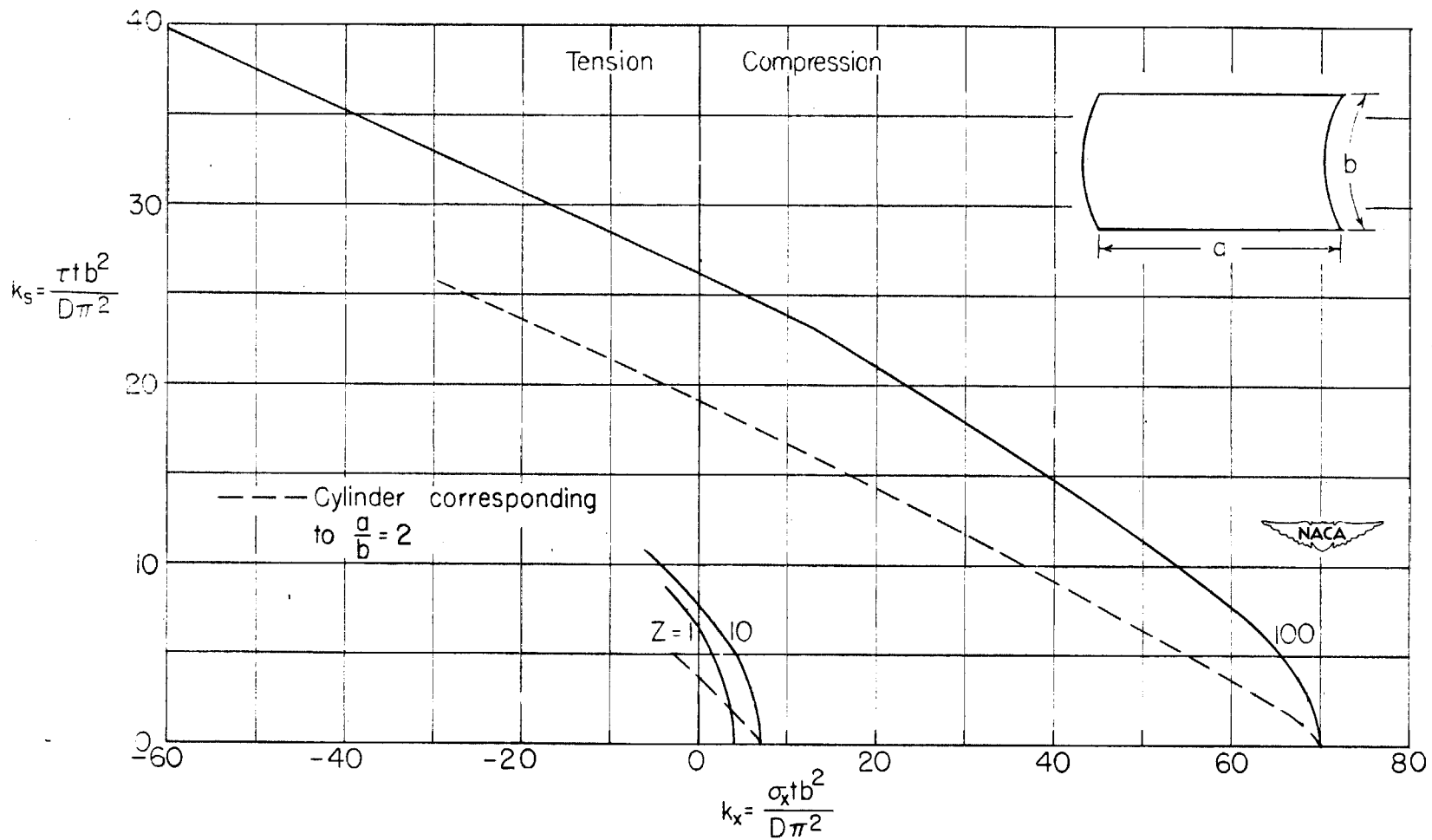
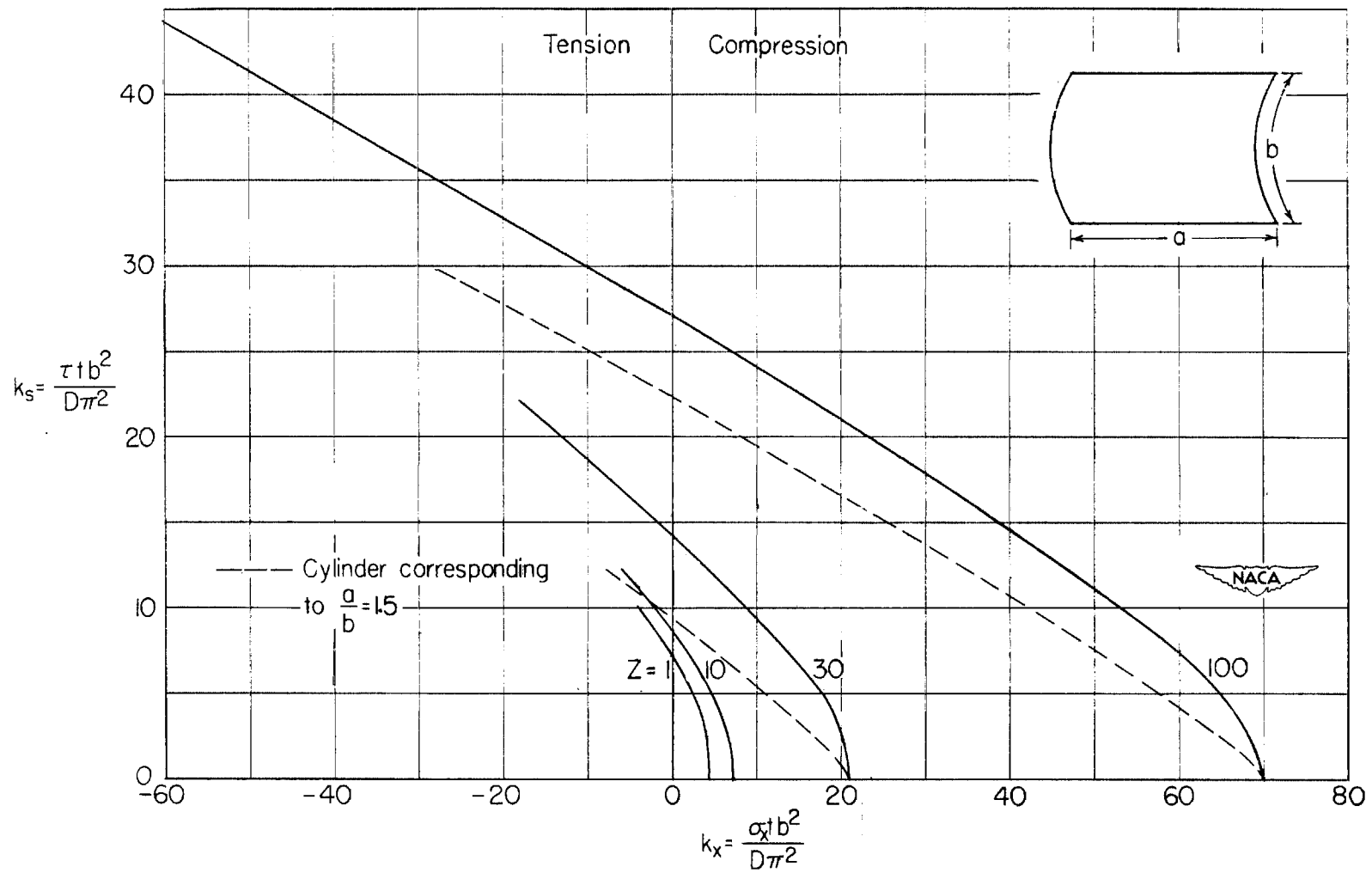

Figure 1.— Curved rectangular panel under a combination of shear and direct axial stress.



(a) $\frac{a}{b} = 2$.

Figure 2.- Critical combinations of shear-stress and axial-stress coefficients for curved rectangular panels with simply supported edges and comparison with cylinder results.



(b) $\frac{a}{b} = 1.5.$

Figure 2.— Continued.

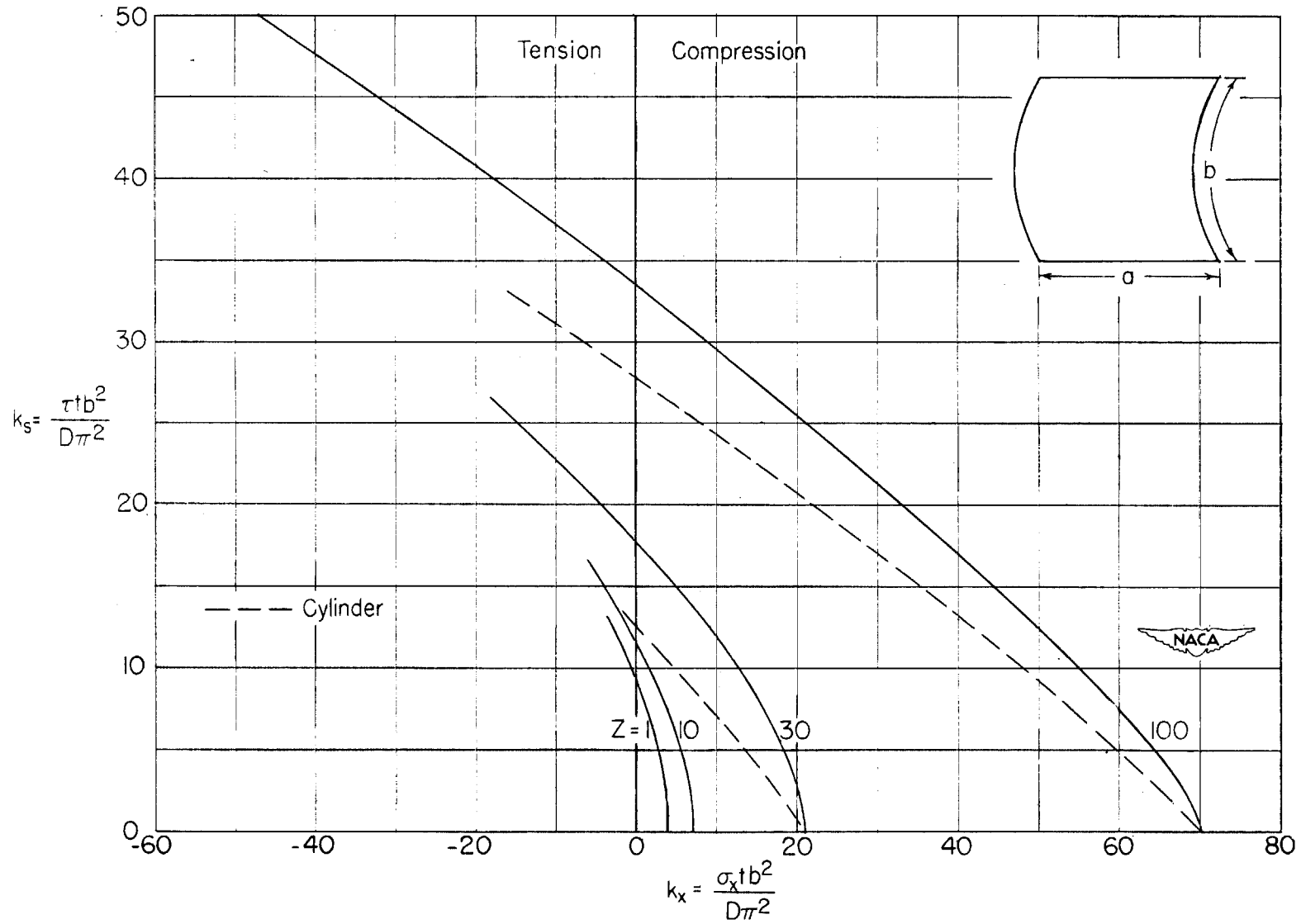

(c) $\frac{a}{b} = 1.$

Figure 2.- Continued.

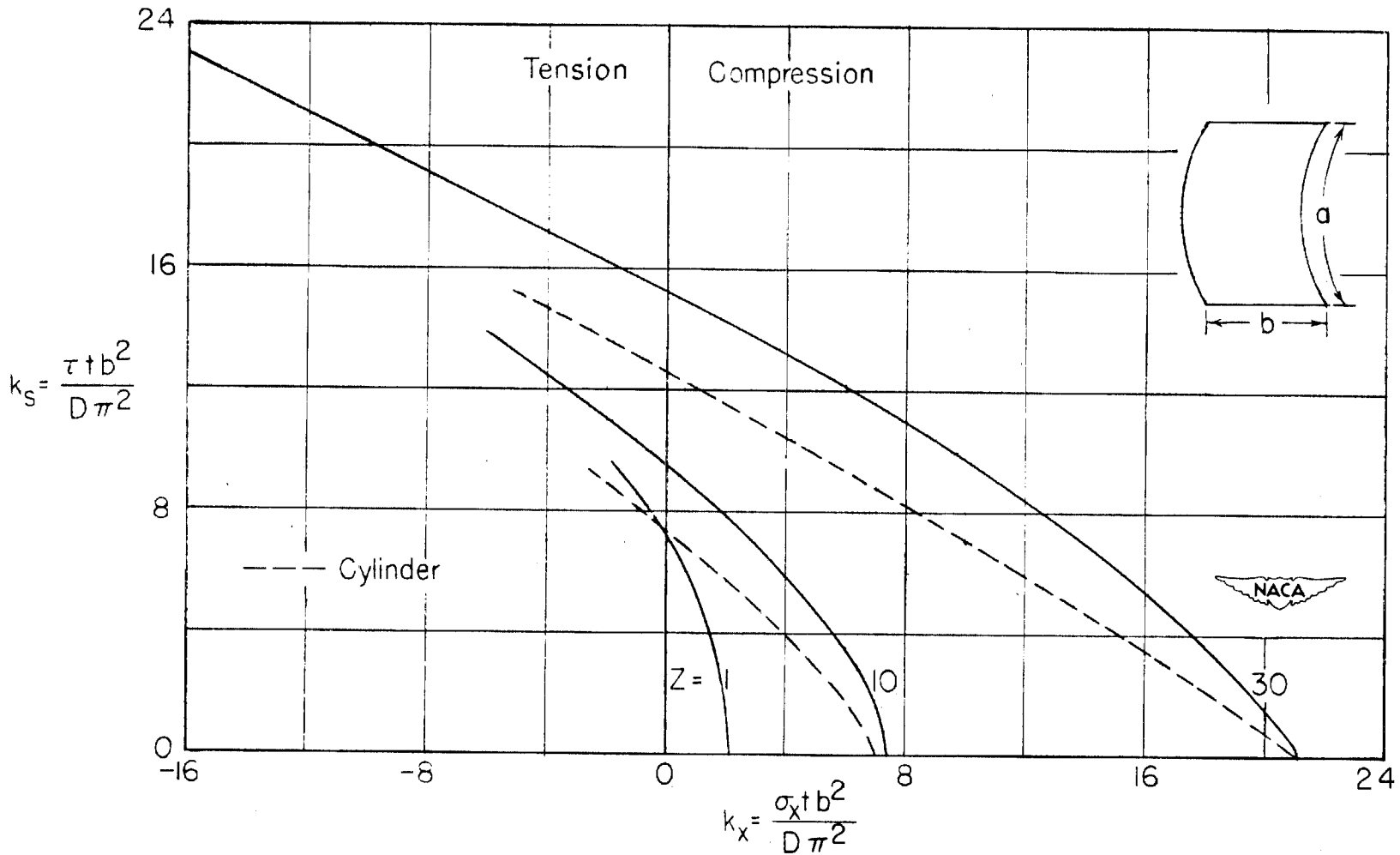

(d) $\frac{a}{b} = 1.5.$

Figure 2.- Continued.

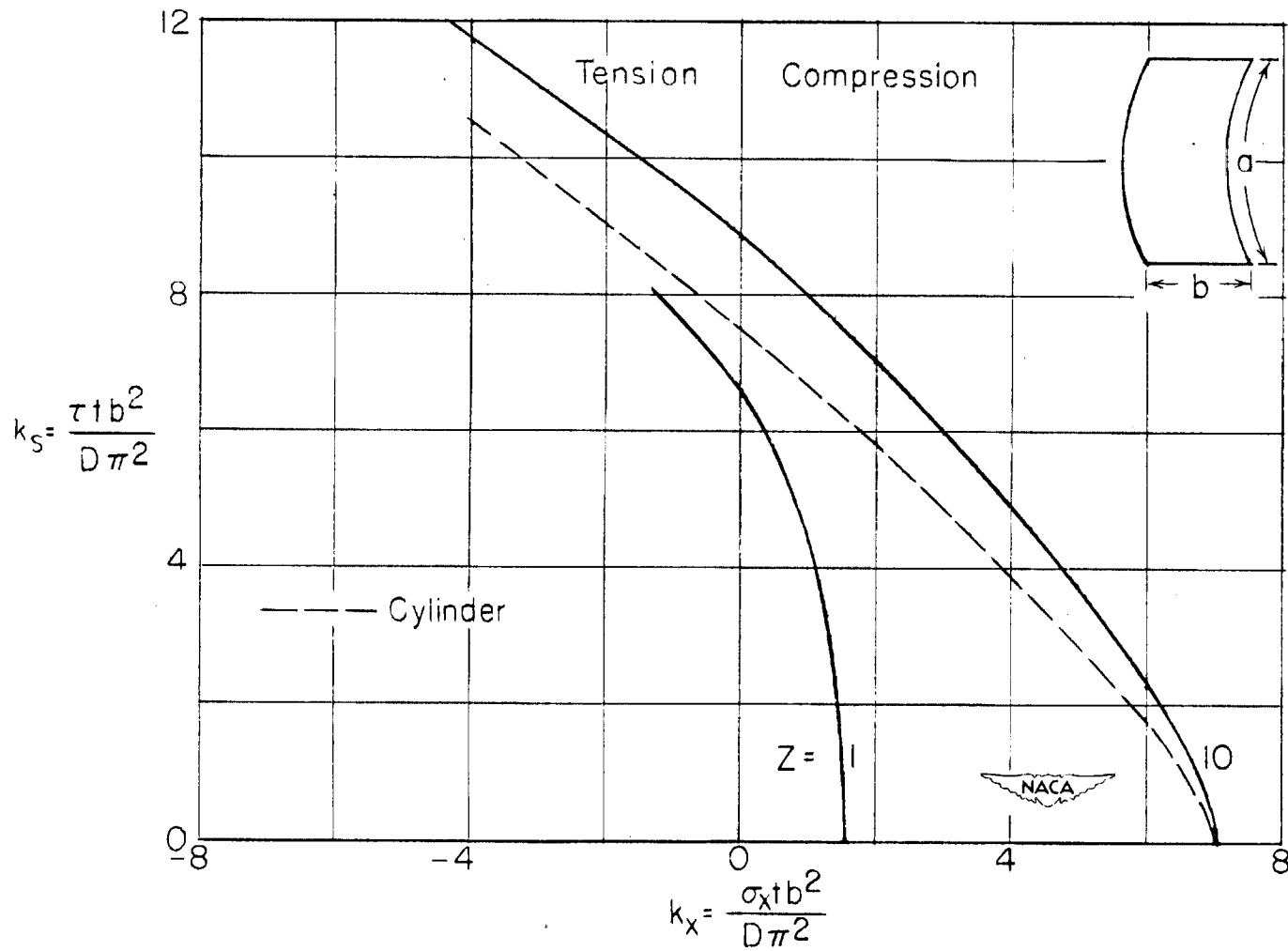

(e) $\frac{a}{b} = 2.$

Figure 2.- Concluded.

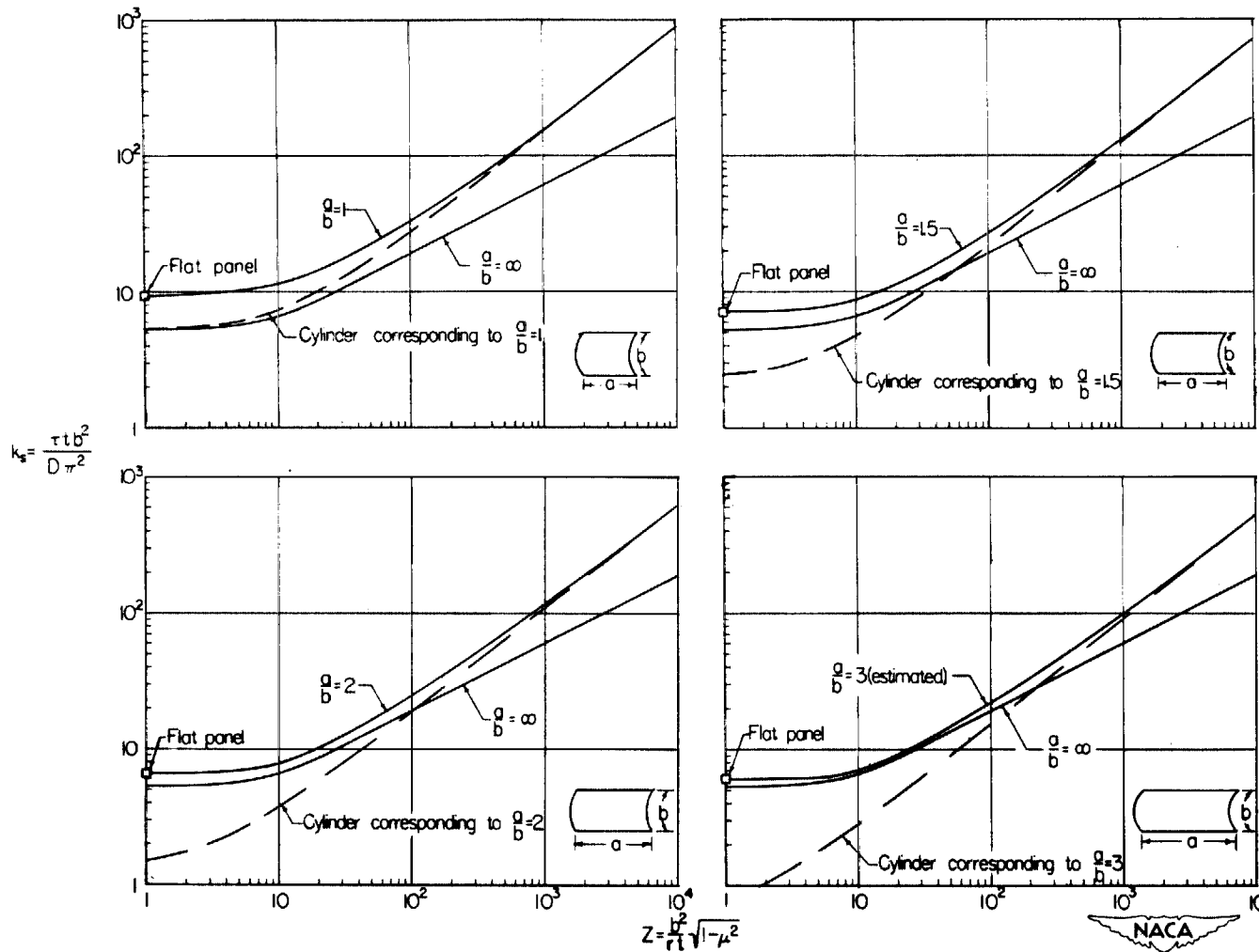

(a) k_s and Z defined in terms of the circumferential dimension of the panel.

Figure 3.— Critical shear stress coefficients of simply supported curved panels compared with cylinders and infinite curved strips. (From reference 1.)

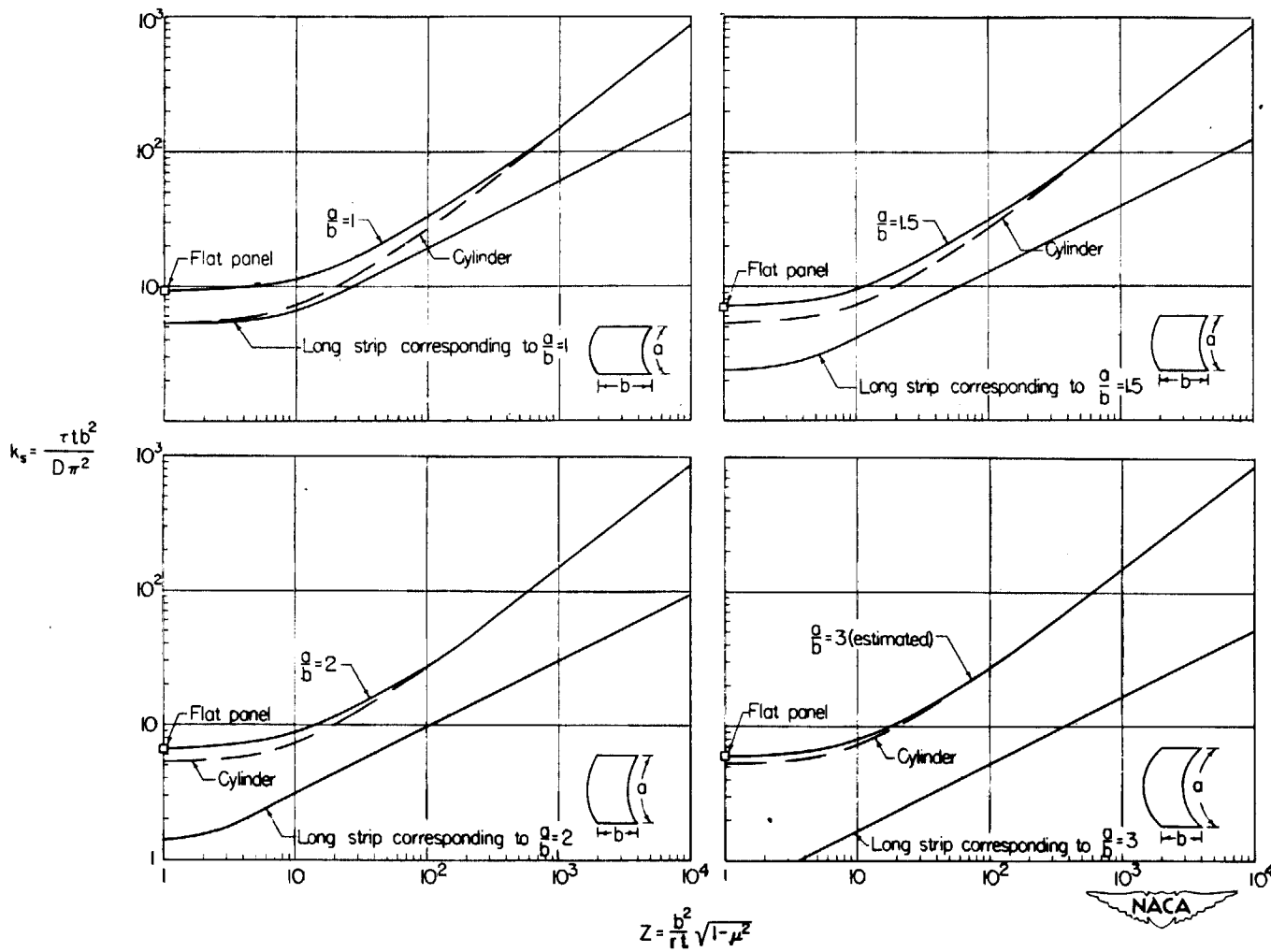

(b) k_s and Z defined in terms of the axial dimension of the panel.

Figure 3.— Concluded.

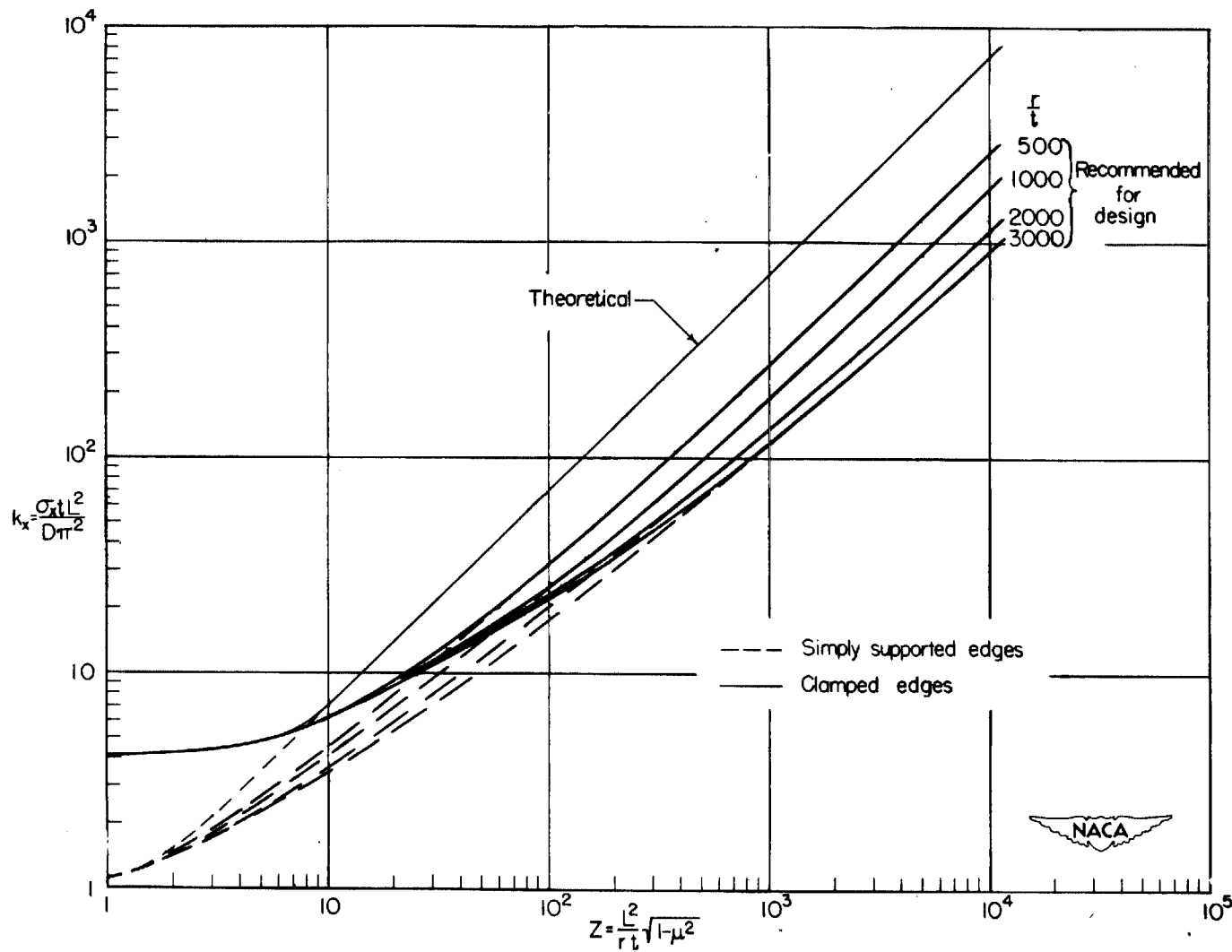

Figure 4.— Critical-stress coefficients for thin-walled circular cylinders subjected to axial compression. L , length of cylinder. (From reference 2.)

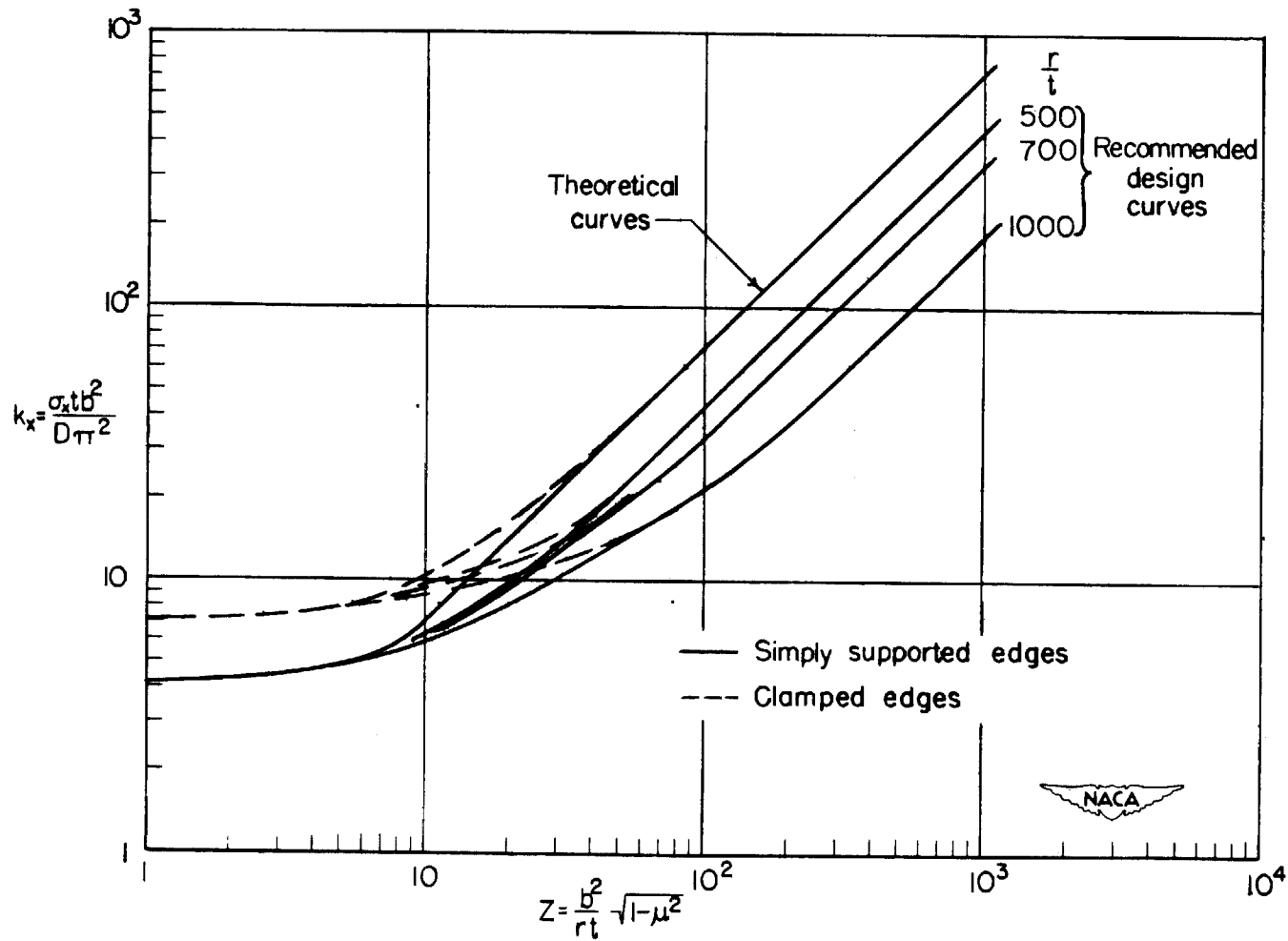
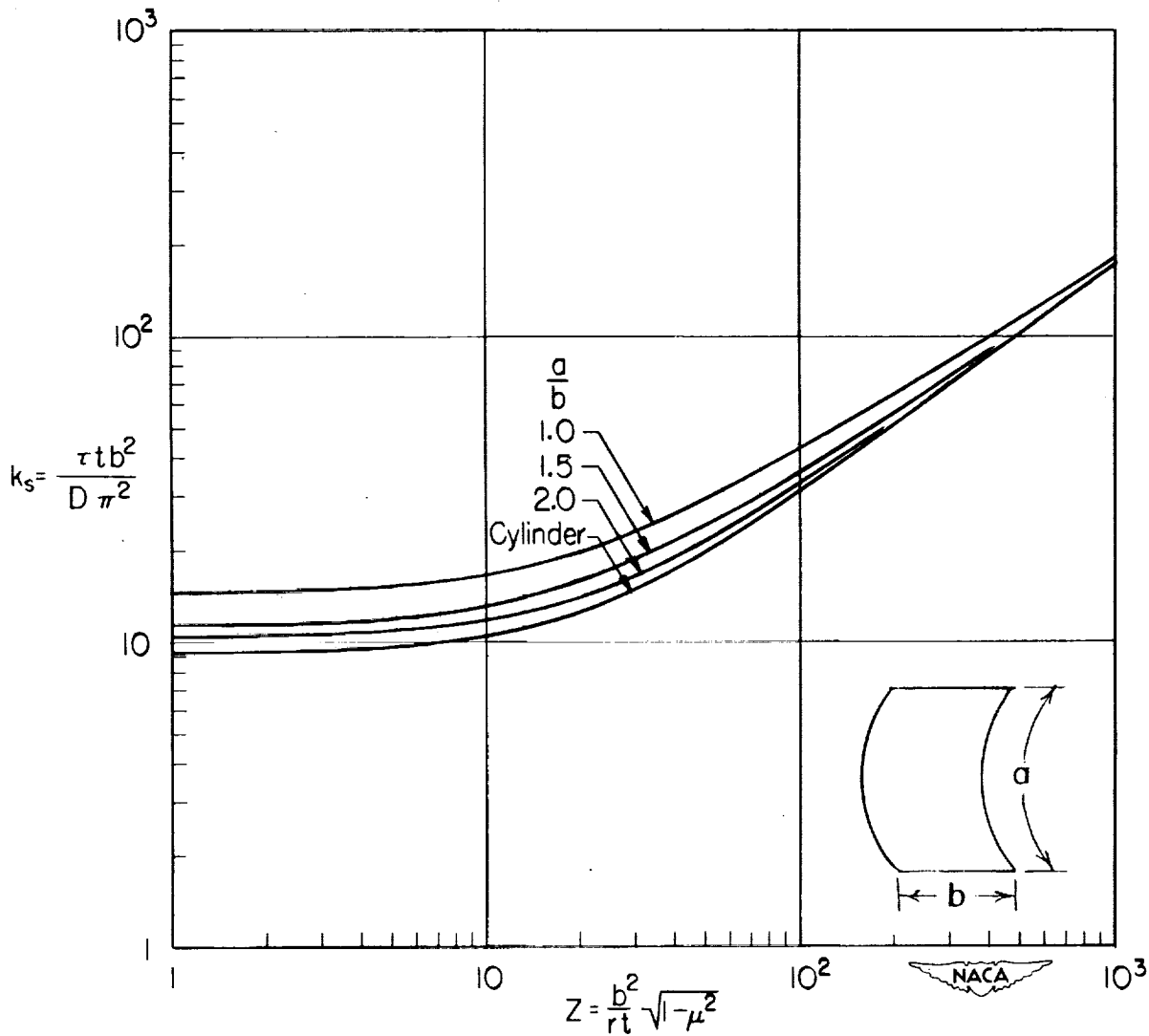
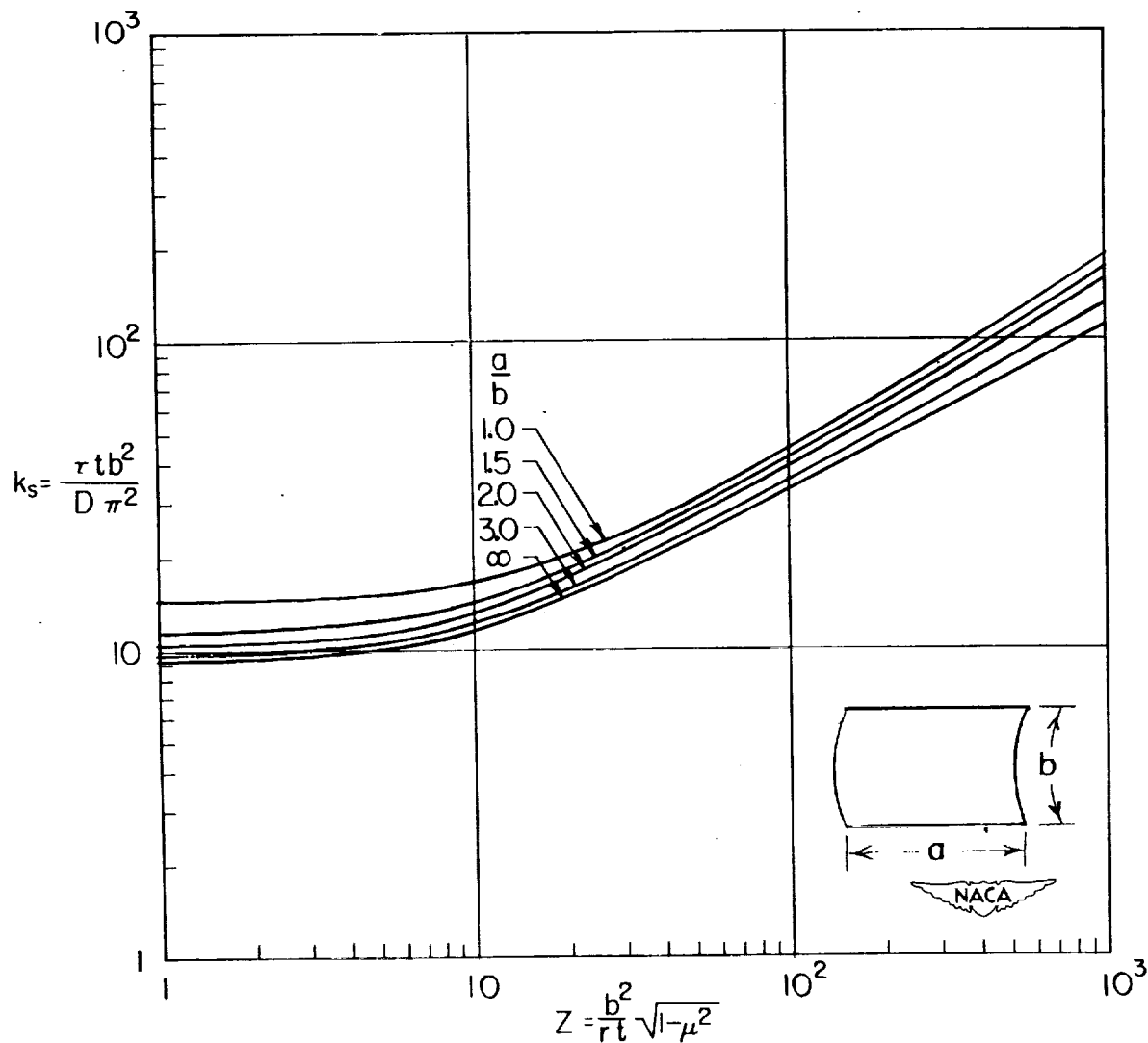

Figure 5.— Critical-axial-compressive-stress coefficients for infinitely long plates with transverse curvature. (From reference 3.)



(a) Circumferential dimension greater than the axial dimension.

Figure 7.— Estimated critical-shear-stress coefficients for curved panels with clamped edges. (From reference 1.)



(b) Axial dimension greater than the circumferential dimension.

Figure 7.- Concluded.

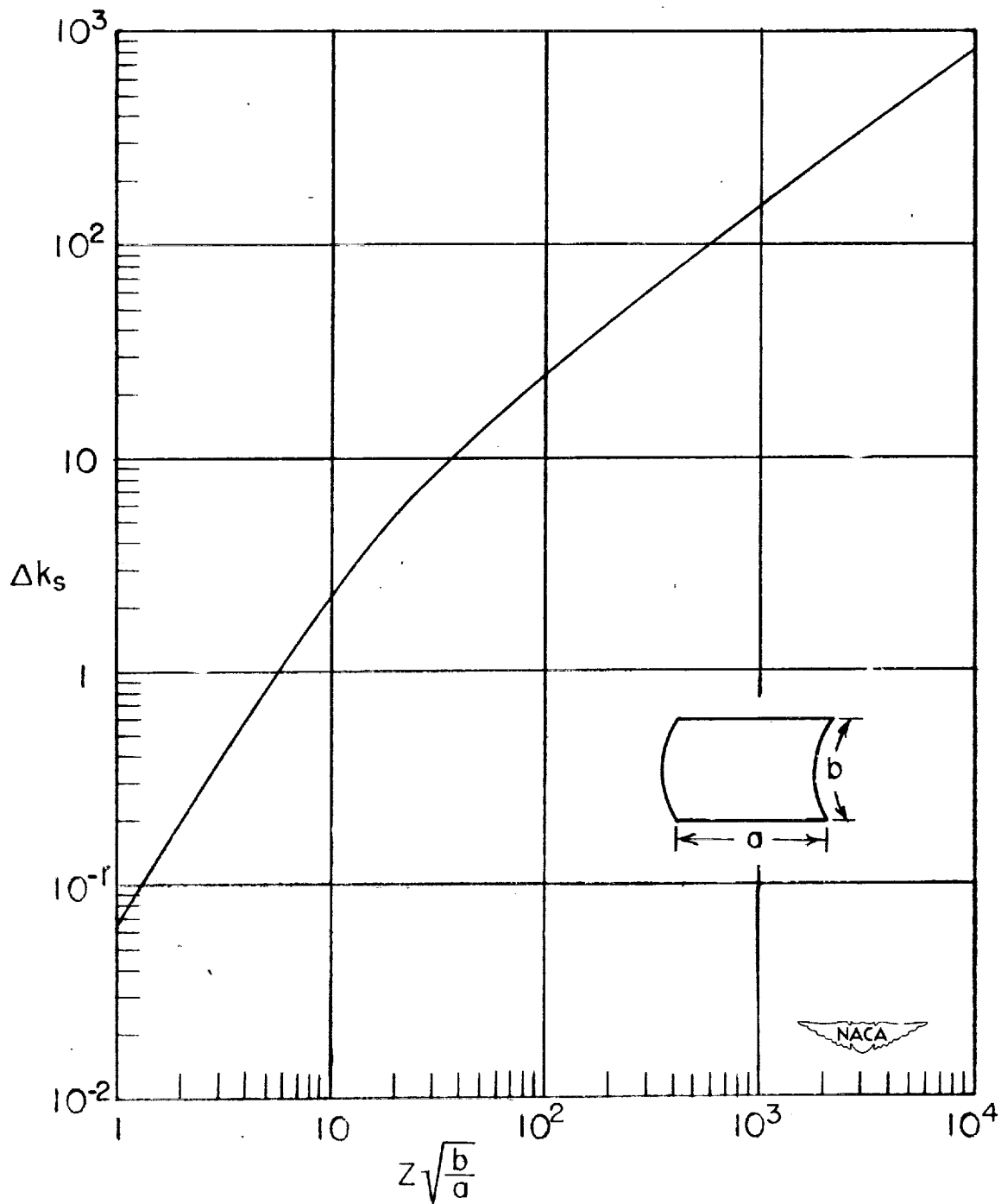

Figure 8.— Increase in the critical-shear-stress coefficient of a simply supported curved rectangular panel over the flat-plate value. (For circumferential dimension greater than axial dimension use $\frac{a}{b} = 1$.)

$$k_s = \frac{\tau t b^2}{D \pi^2}; \quad Z = \frac{b^2}{rt} \sqrt{1 - \mu^2}.$$

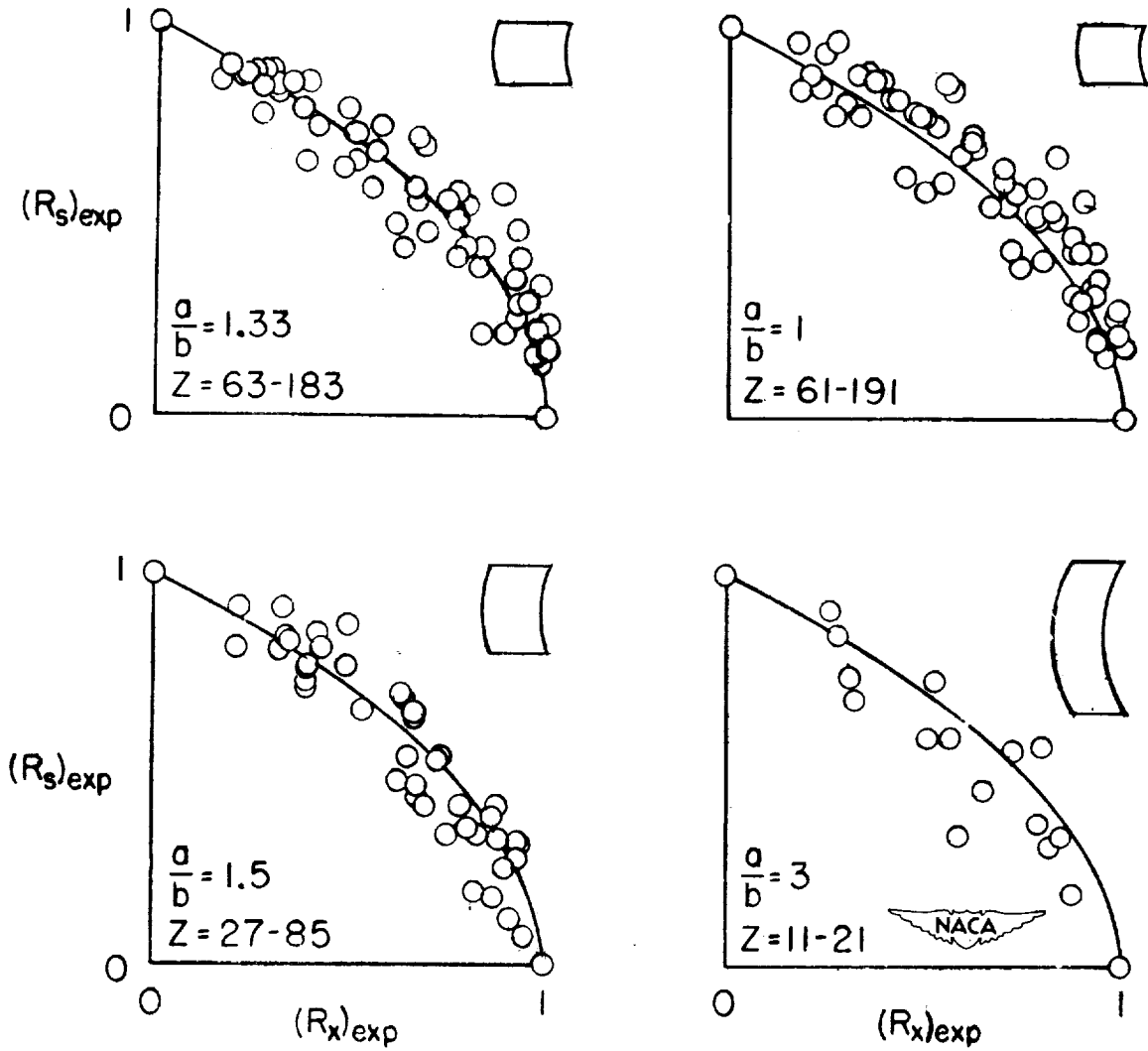

Figure 9.— Test results for buckling of curved rectangular panels under combined shear and compression compared to the parabola $(R_s)_{exp}^2 + (R_x)_{exp} = 1$.

