

NACA TN No. 1728

8176



# NATIONAL ADVISORY COMMITTEE FOR AERONAUTICS

TECHNICAL NOTE

No. 1728

SHEAR LAG IN AXIALLY LOADED PANELS

By Paul Kuhn and James P. Peterson

Langley Aeronautical Laboratory  
Langley Field, Va.



Washington  
October 1948

AFMBC  
TECHNICAL LIBRARY  
AFL 2011

NATIONAL ADVISORY COMMITTEE FOR AERONAUTICS

TECHNICAL NOTE NO. 1728

SHEAR LAG IN AXIALLY LOADED PANELS

By Paul Kuhn and James P. Peterson

SUMMARY

The method of calculating shear-lag effects in axially loaded panels by means of the previously developed concept of the "substitute single-stringer panel" is simplified by an empirical expression for the width of the substitute panel which eliminates the need for successive approximations. For simple types of single-stringer panels, a theory not dependent on the assumption of infinite transverse stiffness is developed that can be used to estimate the effect of transverse stiffness on the stresses in practical panels. Strain measurements on five panels indicate that the theory should be adequate for design purposes and that the effect of transverse stiffness may be appreciable.

INTRODUCTION

The problem of introducing concentrated forces at one end of a longitudinally stiffened panel is a fundamental one in the shear-lag theory and has been treated by a number of authors. The solutions obtained by standard methods of analysis are quite cumbersome even for panels of constant cross section, and most of them are not applicable to the practical case of panels with arbitrarily variable cross section. Moreover, almost all these solutions are based on the assumption of infinite transverse stiffness of the panel; this assumption leads to the result that the maximum shear stress is infinite when there are no discrete stringers attached to the sheet, a result which is so much in error as to be useless to the stress analyst. For a finite number of stringers, the error becomes finite but is still appreciable in the usual range of stringer numbers.

In an effort to provide a practical method of shear-lag analysis, an approximate "substitute single-stringer method" was presented in reference 1. Although this method is also based on the assumption of infinite transverse stiffness, it does not give infinite shear stresses as the mathematically more rigorous methods do; in fact, the agreement between this theory and early tests was found to be fairly good (reference 2). Further study of the problem indicated, however, that some investigation of the influence of finite transverse stiffness was desirable. The results of this investigation are presented in this paper.

Reference 1 describes a successive-approximation method for locating the substitute single stringer. In view of the approximate nature of the method, however, successive approximations appear to be an unwarranted complication. A "one-step" method is therefore developed to locate the substitute stringer. Although this subject is theoretically not directly related to that of finite transverse stiffness, it was found necessary to investigate the two subjects simultaneously, because the formulas developed rest partly on an empirical basis, and in tests the two problems cannot be separated entirely.

The reference material, particularly that of a theoretical nature, is scattered among a number of papers. In order to eliminate the necessity that the reader refer to all these papers, the present investigation incorporates a general discussion of the approximate method and of the relevant features of the rigorous methods.

### SYMBOLS

- A        area, square inches
- E        Young's modulus, pounds per square inch
- G        shear modulus, pounds per square inch
- $$K^2 = \frac{Gt}{Eb} \left( \frac{1}{A_F} + \frac{1}{A_L} \right)$$
- $$K_t^2 = \frac{Gt}{EbA_L}$$
- P        external load on half panel, pounds
- b        half-width of single-stringer panel, inches
- b<sub>C</sub>      transverse distance from centroid of flange to common centroid of stringers in half-panel
- b<sub>S</sub>      transverse distance from flange to substitute single stringer
- $$f = \frac{b_S}{b_C}$$
- n        number of stringers in half panel
- t        sheet thickness, inches (without subscript denotes shear carrying sheet)
- x        distance from tip of panel, inches

$\sigma$  direct stress, pounds per square inch

$\tau$  shear stress, pounds per square inch

Subscripts:

F flange

L longitudinal or stringer

R chordwise rib

S denotes substitute panel

T total

O denotes station at tip ( $x = 0$ )

C denotes centroid of stringer material

#### METHODS AND ANALYSES

Theory of 'single-stringer panel of infinite transverse stiffness.-  
 The single-stringer panel as visualized in the simplified shear-lag theory consists of two flanges F (fig. 1(a)), a stringer L, a connecting sheet capable of developing only shear stresses, and a system of transverse ribs. The ribs are assumed to be infinitely closely spaced; if they are also assumed to have infinite axial stiffness, they do not enter into the theory explicitly and will therefore not be shown in the figures. Throughout this paper, symmetry about the longitudinal axis is assumed to exist so that the analysis can be confined to the half-panel.

For a panel of constant cross section, the equations of equilibrium of the elements (fig. 1(b)) yield the relations

$$-A_F d\sigma_F = \tau t dx = A_L d\sigma_L \quad (1)$$

If the transverse stiffness is infinite, the incremental shear stress caused by the difference between  $\sigma_F$  and  $\sigma_L$  is

$$d\tau = -\frac{G}{Eb} (\sigma_F - \sigma_L) dx \quad (2)$$

Differentiation of expression (2) and substitution into it of the values for  $d\sigma_F$  and  $d\sigma_L$  from equation (1) gives the differential equation

$$\frac{d^2\tau}{dx^2} - K^2\tau = 0 \quad (3)$$

where

$$K^2 = \frac{Gt}{Eb} \left( \frac{1}{A_F} + \frac{1}{A_L} \right) \quad (4)$$

For the present purpose, attention may be confined to infinitely long panels. The solution of equation (3) is then

$$\tau = \frac{PK}{t} \frac{A_L}{A_F} e^{-Kx} \quad (5)$$

A simple solution may also be obtained for a panel in which the flange is tapered so as to maintain constant flange stress (fig. 2(a)). The equilibrium equations are then (fig. 2(b))

$$-\sigma_F dA_F = \tau t dx = A_L d\sigma_L \quad (6)$$

Relation (2) still applies and the differential equation for this case takes again the form of equation (3) with  $K_t^2$  substituted for  $K^2$ , where

$$K_t^2 = \frac{Gt}{EbA_L} \quad (7)$$

The solution is

$$\tau = \frac{PK_t A_L}{tA_{F0}} e^{-K_t x} \quad (8)$$

where  $A_{F0}$  denotes the cross-sectional area of the flange at the tip.

The cross-sectional area  $A_F$  necessary to maintain  $\sigma_F$  constant, obtained by substituting equation (8) into equation (6) and integrating, is

$$A_F = A_{F0} - A_L (1 - e^{-K_t x}) \quad (9)$$

If  $A_{F0} < A_L$ , a constant value of  $\sigma_F$  cannot be obtained.

Rigorous theory of the multistringers panel of infinite transverse stiffness.— For an idealized panel similar to that shown in figure 1(a) but having several stringers, relations corresponding to equations (1)

and (2) can be written for each bay. For a panel such as that shown in figure 3 (two stringers in the half-panel), the result is a set of two simultaneous differential equations

$$\left. \begin{aligned} \frac{d^2\tau_1}{dx^2} - \tau_1 K_{12}^2 + \tau_2 K_{22}^2 &= 0 \\ \frac{d^2\tau_2}{dx^2} - \tau_2 K_{23}^2 + \tau_1 K_{22}^2 &= 0 \end{aligned} \right\} \quad (10)$$

where the coefficients  $K$  are similar in form to the coefficient  $K$  given in equation (4) except that they involve the width of the individual sheet bay and the areas of the adjacent stringers. The solution may be written in the form

$$\left. \begin{aligned} \tau_1 &= C_1 e^{-K_1 x} + C_2 e^{-K_2 x} \\ \tau_2 &= C_3 e^{-K_1 x} + C_4 e^{-K_2 x} \end{aligned} \right\} \quad (11)$$

The constants can be determined by standard methods without difficulty, but the rather cumbersome formulas are not of sufficient interest to be given herein. An equivalent solution may be found in reference 3 in slightly different form (the differential equations are written for the stringer forces instead of the shear stresses).

For panels with more stringers (say 3 to 10 in the half-panel), the standard methods for determining the constants become very cumbersome, and mathematical refinements are desirable. A large amount of work on this subject has been done, chiefly in England. Reference 4 is representative of the results obtained and was used as basis for the comparative calculations to be shown subsequently herein. The stresses are obtained by summing a number of terms of an infinite series after the coefficients for these series have been obtained by solving a transcendental equation for each coefficient; the computations are quite lengthy, particularly for points near the tip of the panel where the convergence is slow.

When the number of stringers becomes very large, the most convenient method of approach is to assume that the stringers are spread out into

a "stringer sheet" of uniform thickness; the set of simultaneous ordinary differential equations is then replaced by a partial differential equation. This problem was solved by investigators in several countries during the war years, with results which are either strictly equivalent or else differ only in minor details. The solution given in reference 5 is used in the present paper because the reference is readily available and contains more numerically computed cases than the others. The stringer-sheet solution may be used as an approximation for panels with a finite number of stringers. The stress in a given stringer is taken as equal to the stress in the corresponding fiber (or "elemental stringer") of the stringer sheet; the shear stress in a sheet bay between two stringers may be similarly taken as the shear stress in the stringer sheet along a line corresponding to the middle of the sheet bay. In regions where the shear stress changes rapidly in the chordwise direction, somewhat better results are obtained by integrating the shear stress in the stringer sheet between two lines corresponding to the stringers bounding the sheet bay in question. Graphs and formulas based on these methods are given in reference 6, and comparisons made by British investigators show that there is fairly close agreement with the results obtained by solving sets of simultaneous differential equations like equations (10) when the number of stringers in the half-panel is as low as five.

Very few attempts have been made to extend any of these mathematical methods to panels with variable cross section, and the computational labor involved is too large to consider them as practical methods for general use.

The substitute single-stringer method of analyzing multistringers panels.— In practice, the flanges of multistringers panels are strongly tapered in order to reduce the weight. Because the more rigorous methods of analyzing multistringers panels discussed in the preceding section cannot deal with panels of arbitrarily variable section without excessive labor, if at all, a simplified method was developed and presented in reference 1. The basic idea in this method is that the designer need not know all the details of the stress distribution in the panel. He needs to know primarily two items: the maximum shear stress, because it determines the sheet thickness required, and the shear flow along the flange, because it determines the rivet design; in addition, he must be able to compute the flange stress in order to insure that the flange is not tapered too rapidly. This information can be obtained with a fair degree of accuracy by analyzing a simplified "substitute panel" that is identical with the actual panel except that all the stringers contained in the half-width are combined into a single stringer. The chordwise location of this substitute stringer had to be established by theoretical or experimental data.

The procedure given in reference 1 was as follows. In first approximation, the substitute stringer is located at the common centroid of the stringers which it replaces. The analysis of the "substitute single-stringer panel" gives a first approximation for the chordwise average of the stringer stresses at all stations along the span. The chordwise

distribution of these stresses is then computed by use of an assumed simple law of distribution. The chordwise location of the centroid of the stringer forces is next calculated and used as second approximation for the location of the substitute stringer, and the process is repeated, if necessary, until the changes become negligible.

Test results showed reasonable agreement with those calculated by the foregoing procedure; however, because of the approximate nature of the method, the use of successive approximations appears somewhat unjustified. A procedure will therefore be developed later in this paper for establishing the location of the substitute stringer directly.

The substitute single-stringer panel with arbitrary variation of cross section along the span can be analyzed by means of the recurrence formula given in reference 7. One item should be noted that is not covered in this reference. The elementary solution is defined as that giving the normal stresses

$$\sigma_F = \sigma_L = \frac{P}{A_F + A_L} = \frac{P}{A_T} \quad (11)$$

Now, if  $A_F$  or  $A_L$  (or both) vary along the span, the "elementary flange force" (the flange force given by the elementary theory)

$$F_F = \frac{PA_F}{A_T}$$

and the (total) "elementary stringer force"

$$F_L = \frac{PA_L}{A_T}$$

will also vary along the span. For static equilibrium, this variation calls for "elementary shear flows"

$$q = \frac{dF_L}{dx} = P \frac{d}{dx} \left( \frac{A_L}{A_T} \right) = -P \frac{d}{dx} \left( \frac{A_F}{A_T} \right) \quad (12)$$

These elementary shear flows must be added to those arising from the X-forces of the shear-lag analysis made according to reference 7.

When the area  $A_F$  (or  $A_L$ ) varies along the span by steps, formula (12) would give an infinite shear flow that acts, however, only over an infinitesimally small distance along the span; the elementary shear force is therefore mathematically indeterminate. Physical

consideration of the problem suggests that the step-curve of area variation should be replaced by a continuous curve for the purpose of evaluating formula (12). If the steps are close together, or small, a fair curve may be drawn to represent the "effective" variation of area. If the steps are not close together and are large, the "effective" curve will undoubtedly not be fair (though continuous) but there is neither theory nor experimental evidence available at present to serve as a guide in estimating this curve. It will be advisable, therefore, to avoid this uncertainty by avoiding a large step close to the tip of the panel, where the shear stress is a maximum. The elementary shear flow in a panel with constant-stress flange and a ratio  $A_{FO}/A_L$  equal to unity constitutes 25 percent of the total shear flow; the problem of estimating the effective value of  $\frac{d}{dx} \left( \frac{A_F}{A_T} \right)$  at the tip is therefore of some importance.

The maximum shear stress probably always occurs in the sheet bay adjacent to the flange; consequently, for design purposes, there is no apparent need for finding the chordwise distribution of the shear stresses. The maximum stringer stress may be either the uniform stress existing at a large distance from the tip of the panel or a local peak close to the tip in the first stringer. If this local peak should be of design interest, the stringer stresses in the tip region can be estimated by the procedure for chordwise distribution given in reference 1.

Theory of single-stringer panel with finite transverse stiffness.—The substitute single-stringer method of analyzing multistringers panels, based on the theory of the single-stringer panel of infinite transverse stiffness, has been applied quite successfully to a number of test panels (references 1, 2, and other data). This fact suggested that the substitute single-stringer method might also be used to develop an approximate theory for panels with finite transverse stiffness.

The panel is again visualized as in figure 1(a). The axial stiffness of the ribs is now assumed to be finite. Because the ribs are assumed to be infinitely closely spaced, they may be considered as forming a rib sheet; the thickness  $t_R$  of this sheet defines the extensional stiffness of the ribs. (The rib sheet has, of course, zero longitudinal and shear stiffness). At the tip, a special rib of cross-sectional area  $A_R$  is assumed to exist (fig. 4(a), where the ribs are shown a finite distance apart for practical reasons).

A rib away from the tip is loaded by the difference in the shear flows to either side of it (fig. 4(c)); these differences are small and practically vanish at some distance from the tip. The tip rib, however, is loaded by the full shear flow existing at the tip (fig. 4(b)) and is, therefore, relatively heavily strained. The effect of finite transverse stiffness may consequently be expected to be chiefly a tip effect, and a theory developed for long panels should be adequate for most practical needs.

The shear stress  $\tau$  may be considered as made up of two parts

$$\tau = \tau' + \tau'' \quad (13)$$

where the part  $\tau'$  is due to the longitudinal strains (flange and stringer strains) and the part  $\tau''$  is due to the transverse strains (rib strains). The equilibrium equations (1) written for the panel with infinite transverse stiffness remain unchanged, but equation (2) must be changed to read

$$\frac{d\tau'}{dx} = -\frac{G}{Eb} (\sigma_F - \sigma_L) \quad (14)$$

As mentioned before, any elemental rib is loaded by the difference between the shear flows to either side of it (fig. 4(c)). Since the shear flows are constant between the flange and the stringer, the rib stress increases linearly from zero at the flange to a maximum at the stringer. For convenience, let  $\sigma_R$  designate the average stress in a rib; the rib stress at the stringer is then  $2\sigma_R$ . The equilibrium equation for a rib then yields the expression

$$\sigma_R t_R = -\frac{1}{2} bt \frac{d\tau}{dx} \quad (15)$$

The total extension of a rib is therefore

$$\delta_R = \frac{\sigma_R}{E} b = -\frac{b^2 t}{2Et_R} \frac{d\tau}{dx} \quad (16)$$

The derivative of this extension defines a shear strain along the flange (fig. 4(d))

$$\gamma = -\frac{d\delta_R}{dx}$$

The shear strain decreases linearly along the rib to zero at the stringer. The theory of the single-stringer panel used herein, however, requires the assumption that the shear stress is constant along the rib; the average value (1/2) of the shear strain is therefore used to calculate the part of the shear stress caused by transverse strains as

$$\tau'' = -\frac{1}{2} G \frac{d\delta_R}{dx} = \frac{Gb^2 t}{4Et_R} \frac{d^2 \tau}{dx^2} \quad (17)$$

Differentiating twice, and letting

$$\frac{Gb^2t}{4Et_R} = \alpha \tag{18}$$

yields

$$\frac{d^2\tau}{dx^2} = \alpha \frac{d^4\tau}{dx^4} \tag{19}$$

Differentiation of expression (14) gives

$$\frac{d^2\tau}{dx^2} = -\frac{G}{Eb} \left( \frac{d\sigma_F}{dx} - \frac{d\sigma_L}{dx} \right)$$

which can be transformed with the aid of the equilibrium equations (1) into

$$\frac{d^2\tau}{dx^2} = K^2\tau \tag{20}$$

where K has the same meaning as given before in formula (4). If equations (19) and (20) are added and the defining expression (13) is introduced, a slight rearrangement of terms gives the differential equation

$$\frac{d^4\tau}{dx^4} - \frac{1}{\alpha} \frac{d^2\tau}{dx^2} + \frac{K^2}{\alpha} \tau = 0 \tag{21}$$

This equation reduces to equation (3) for the panel with infinite transverse stiffness if it is multiplied through by  $\alpha$  and  $t_R$  is then increased indefinitely.

The solution of the differential equation for the infinitely long panel is

$$\tau = C_1 e^{-K_1 x} + C_2 e^{-K_2 x} \tag{22}$$

where the constants K are defined by

$$K_1^2 = \frac{1}{2\alpha} \left( 1 + \sqrt{1 - 4K^2\alpha} \right) \tag{23}$$

$$K_2^2 = \frac{1}{2\alpha} \left( 1 - \sqrt{1 - 4K^2\alpha} \right) \quad (24)$$

Because  $K^2\alpha$  is often small, the computation of  $K_2$  may give trouble when the slide rule is used; the difficulty may be avoided by using the approximation

$$K_2 \approx K \left( 1 + \frac{1}{2} K^2\alpha \right) \quad (25)$$

The constants  $C_1$  and  $C_2$  are determined from the boundary conditions. One condition is, at  $x = 0$ ,

$$\sigma_F = \frac{P}{A_F}$$

and

$$\sigma_L = 0$$

The other condition is that the strain in the tip rib must be equal to the strain in the adjacent edge of the rib sheet, or the strain in the adjacent elemental rib. The strain in the tip rib (fig. 4(b)) is given by the expression

$$\epsilon_{R_0} = \frac{\sigma_R}{E} = - \frac{\tau_0 b t}{2A_R E}$$

and the strain in the adjacent elemental rib is obtained by modifying expression (16) as

$$\epsilon_{R_0} = - \frac{b t}{2E t_R} \left( \frac{d\tau}{dx} \right)_0$$

With these boundary conditions, and with the auxiliary parameters

$$\left. \begin{aligned} \beta &= \frac{GP}{E b A_F} \\ \gamma &= \frac{t_R + K_2 A_R}{t_R + K_1 A_R} \end{aligned} \right\} \quad (26)$$

the constants are found to be

$$C_2 = - \frac{\beta}{\frac{E}{A_R}(1 - \gamma) - \alpha(\gamma K_1^3 - K_2^3)} \quad (27)$$

$$C_1 = -\gamma C_2 \quad (28)$$

For an infinitely stiff tip rib ( $A_R \rightarrow \infty$ ), the expressions simplify to

$$\gamma = \frac{K_2}{K_1} \quad (29)$$

$$C_2 = \frac{\beta}{K_2 \sqrt{1 - 4K^2 \alpha}} \quad (30)$$

$$C_1 = -\gamma C_2 \quad (31)$$

When there is no tip rib ( $A_R = 0$ ),

$$\gamma = 1$$

$$C_1 = -C_2$$

and consequently  $\tau_0 = 0$ , as it must be because no shear stress can exist along a free edge.

Inspection of the derivation shows that the formulas are applicable to a panel with a constant-stress flange if  $A_F$  is understood to be  $A_{F0}$  in the expression for  $\beta$  and  $K$  is replaced by  $Kt$ . If the sheet carries discrete transverse stiffeners of area  $A_{tr}$  and pitch  $d$ , the thickness of the rib sheet lies between the limits

$$t + \frac{A_{tr}}{d} \geq t_R \geq \frac{A_{tr}}{d} \quad (32)$$

The upper limit applies when the sheet is not buckled, the lower limit when the sheet is fully buckled. For a buckled sheet, the value of  $G$  must also be reduced. Because the effect of finite transverse stiffness

is localized near the tip, transverse stiffeners should probably be disregarded unless their pitch  $d$  is less than  $1/K_1$ .

Location of substitute stringer established by comparison with "rigorous" methods.— The location of the substitute single stringer may be defined by the expression

$$b_S = fb_C \quad (33)$$

where  $f$  is a factor less than unity. In an attempt to establish this factor on a theoretical basis, comparative calculations were made for a number of multistringers panels as follows. Three types of panels were selected, each type having two, six, or infinitely many stringers in the half-width. For each type, panels of two proportions were selected, one panel in which the flange area  $A_F$  was a fraction of the total stringer area  $A_L$  and one panel in which  $A_F$  was a multiple of  $A_L$ . The ratios  $A_F/A_L$  chosen were not the same for all types of panels because available results were used whenever possible. For each of the six panels thus selected, the shear stress along the edge was computed by a "rigorous" method (infinite transverse stiffness being assumed) and again by the substitute single-stringer method for three assumed values of the factor  $f$ . The shear stress was chosen as a basis of comparison in preference to the flange stress because it is a more sensitive criterion. (The flange stress is known from elementary statics at both ends of the panel; consequently, no theory can err very much on the flange stress.)

For the two-stringer panel, equations (10) were set up and solved; for the six-stringer panel, the method of reference 4 was used, and, for the stringer sheet, the method of reference 5.

The results are shown in figure 5. For the two-stringer panel with a small flange (fig. 5(a)),  $f = 0.7$  gives a very close approximation (within a fraction of a percent); with the large flange (fig. 5(b)), the error is about 4 percent, the substitute single-stringer method giving the higher shear stress. For the six-stringer panel with a small flange (fig. 5(c)),  $f = 0.5$  gives the best approximation, and the inspection of the curves indicates that the agreement could be improved by use of a smaller value of  $f$ . For the six-stringer panel with a large flange (fig. 5(d)),  $f = 0.5$  gives the best approximation for the maximum shear stress, although not the best one for the stress at some distance away from the tip.

For the stringer sheet, the rigorous theory gives an infinite shear stress at the tip. By the substitute single-stringer method, this value cannot be obtained if a reasonable approximation to the rigorous shear stresses at finite distances away from the tip is also to be obtained. The single-stringer method in which a finite value of the factor  $f$  is

used is capable only of approximating the rigorous shear stresses over a certain region away from the tip (figs. 5(e) and 5(f)) and yields then finite values of maximum shear stress. If the infinite shear stress of the rigorous theory were to be obtained by the single-stringer theory, it would be necessary to make the factor  $f$  equal to zero.

The results may be summarized as follows: In order to achieve the best possible agreement between the maximum shear stress calculated by the substitute single-stringer theory and that calculated by the rigorous theories based on the assumption of infinite transverse stiffness, the factor  $f$  should be taken as about 0.7 for two-stringer panels and should be progressively decreased to zero as the number of stringers goes to infinity.

The preceding comparisons are essentially of academic rather than practical interest. Actual panels have only finite transverse stiffness, and the factor  $f$  would therefore be determined best by comparisons with rigorous theories based on the assumption of finite transverse stiffness which would eliminate the difficulty of dealing with the infinite shear stresses encountered in the limiting case of infinitely many stringers. Unfortunately, the only theories available (references 8 and 9) require laborious calculations, and experimental checks would still be desirable because simplifying assumptions are made even in these theories. For these reasons, further work on the theoretical determination of the factor  $f$  was abandoned in favor of a direct empirical determination.

Empirical location of substitute stringers and verification of theory for finite transverse stiffness.— For the empirical determination of the factor  $f$ , shear strain measurements alongside the flanges of three panels of constant section and two panels of variable section were used. The constant-section panels are shown in figure 6. Panel A had been tested previously (reference 2). Panel B was built to the same nominal dimensions as panel A, except that the heavy tip rib was replaced by a very light rib. The rigorous theory based on the assumption of infinite transverse stiffness indicates that the number of stringers in these panels is sufficient to be considered as "large," in the sense that the stress distribution does not differ appreciably from that in a panel with an infinite number of stringers, the main difference being the finite value of the peak shear stress. However, panel C was built in order to obtain a direct check for this limiting case. The shear stresses in the sheet were measured with Tuckerman optical strain gages placed as close to the flanges as the gage length of 2 inches would permit.

Tests were also available on two panels with tapered flanges and a small number of stringers (fig. 7). These panels differed mainly in that panel D had flanges machined from one piece, while the flanges of panel E were built up.

Preliminary calculations for the constant-section test panels were made as follows. Three values of the factor  $f$  (the same three that were used for the comparisons in figure 5) were chosen. For the resulting substitute single-stringer panels, the shear stresses were calculated on the assumption of infinite as well as finite transverse stiffness with the theory developed herein.

Preliminary calculations for the tapered-flange panels D and E were slightly more involved. The first step was the calculation of shear stresses based on the assumption of infinite transverse stiffness by means of the recurrence formula and expression (12). A "reference panel" was then introduced that was similar to the actual one except that, starting just beyond the tip, taper was incorporated into the flange in such a manner as to give constant flange stress. For this reference panel, shear stresses  $\tau_1$  were calculated on the assumption of infinite transverse stiffness and stresses  $\tau_2$  on the assumption of finite stiffness. The ratio  $\tau_2/\tau_1$  was then used to correct the shear stresses calculated in the first step. This method was justified by the facts that the flanges had roughly constant stress and that the correction factors did not differ greatly from unity.

Inspection of figures 8(a), 8(b), and 8(c) shows that even though the factor  $f$  is varied over quite a wide range (from 0.5 to 0.9), the curves contract into a rather narrow band at some distance from the tip; they fan out only in the tip region. The choice of the factor must therefore be based chiefly on comparisons between experimental and calculated stresses in the tip regions, a procedure which is also desirable because the largest stresses exist in the tip region. Some consideration should be given, of course, to the stresses in the remainder of the panels.

The preliminary comparisons showed that a factor  $f = 0.7$  gave fair results for all five panels, although three different stringer numbers were represented ( $n = 7$  for panels A and B,  $n = \infty$  for panel C,  $n = 3$  for panels D and E). On the other hand, the comparisons with rigorous theories shown in figure 5 indicated that the factor should increase with decreasing stringer number, and for a (half) panel with a single stringer, the factor should logically be equal to unity, because the substitute panel should be identical with the actual one in this limiting case. (The "actual" panel referred to is, of course, an idealized one in which the sheet carries only shear.) Closer comparisons between the curves for  $f = 0.7$  and the experimental results indicated that the agreement could be improved somewhat by making  $f$  variable in agreement with these considerations. The test data are inadequate to establish  $f$  as a function of  $n$  with a high degree of accuracy, particularly when  $n$  is very small ( $n = 3$  or  $2$ ). Fortunately, the calculations indicate that the results are not sensitive to changes in  $f$ , and panels with very few stringers are of little practical interest. As a tentative solution, the expression

$$f = 0.65 + \frac{0.35}{n} \quad (34)$$

was chosen after consideration was given to such differences as existed between the test results and the preliminary curves based on  $f = 0.7$ . (Some judgment should be used when the ratio of stringer area to normal-stress-bearing sheet area is very much less than in the test panels. If a very small stringer were attached at the center line of panel C, the stress obviously would change very little, and  $n$  should be taken as infinity rather than unity in expression (34).)

Figures 8 and 9 show that the solid-line curves calculated with expression (34) agree quite well not only with the measured peak stresses, but in general also with the measured stresses along the entire length of the curves. The highest measured stress in panel A (second test point from tip) is about 4 to 6 percent higher than the calculated stress, but comparison with the first point indicates the probability of a local irregularity or a test error. Of particular interest is the close agreement between measured and calculated stresses in panel B with the very light tip rib. The difference between the curves calculated for this panel on the assumption of either infinite or finite transverse stiffness is very marked and indicates that a shear-lag theory satisfactory over the entire range of design proportions cannot be obtained if the transverse stiffness is assumed to be infinite. Panel B has a lighter tip rib than is likely to be encountered in practice; however, even on panels A and C, which have tip ribs considerably heavier than likely to be found in practice, the effect of finite transverse stiffness on the peak shear stress is appreciable (of the order of 20 percent).

Figure 8(d) shows the flange stresses in panel C. There is a surprisingly large variation of stress over the width of the flange, which is only 1 inch wide; the variation disappears at a distance from the tip equal to about 6 times the flange width.

On panels D and E, the calculated effect of finite transverse stiffness on the peak shear stresses was fairly small (figs. 9(a) and 9(b)), and the calculated stresses exceed the measured stresses nearest the panel tips by 4 percent and 10 percent, respectively. The discrepancies can probably be attributed largely to a simplifying assumption implied in the theory. The transverse ribs have a finite bending stiffness within the plane of the panel; they are therefore capable of transferring some load from the flange to the stringers, and they restrain the shear deformation at the corners of the panels. This rib effect is neglected by the present theory; it was more important in panels D and E than in the other panels because the ribs were stiffer by virtue of smaller length, greater section, or both.

In the calculations shown for panels D and E, the transverse ribs (other than the tip rib) were disregarded. Calculations were also made on the assumption that the material in these ribs was uniformly distributed spanwise to equal distances on either side from the actual location of each rib, with the result that the value of  $t_R$  (thickness of "rib-sheet") was greatly increased. On the other hand, the value of  $A_R$  was

decreased because a part of the material in the actual tip rib was assumed to be spread out to form the rib sheet in the outboard half of the tip bay. (This procedure appears to be the most logical one and was also suggested in reference 9). The increase in  $t_R$  and the decrease in  $A_R$  counteracted each other, and the stresses calculated in this manner were practically identical with those shown in figures 9(a) and 9(b). In general, such close agreement between the two methods of calculation cannot be expected. Because the first transverse rib lies at a station where the shear transfer is largely completed, the first method of calculation (the ribs being entirely disregarded) is probably more appropriate. If the pitch of the ribs were, say, 5 inches or less rather than 21 inches, the second method would seem more appropriate.

Figures 9(c) and 9(d) show the flange stresses in panels D and E. The measured stresses shown are those on the top surfaces; the "feather edge" of each strap carries only a low stress because the first rivet is not stiff enough to transmit the full load to the strap. Investigation of this "shear-lag effect" within the pack on other panels has shown that the average stress in the pack agrees well with the calculated stress; the deficiency of stress in the outermost straps is compensated by an excess in the innermost straps which has been found to be as high as 30 percent in packs of somewhat similar proportions.

#### CONCLUSIONS

The method of calculating shear-lag effects in axially loaded panels by means of the previously developed concept of the substitute single-stringer panel is improved in two respects:

(a) The width of the substitute panel is calculated by an empirical formula which eliminates the successive approximation procedure used previously.

(b) A method for taking into account finite transverse stiffness is introduced.

Test results on three panels of constant section having a "large" number of stringers agreed within 4 percent with the calculations. On two panels with tapered flanges having only 3 stringers in the half-panel, the calculated peak shear stresses exceeded the measured values by 4 percent and 10 percent, respectively.

Langley Aeronautical Laboratory  
 National Advisory Committee for Aeronautics  
 Langley Field, Va., August 16, 1948

REFERENCES

1. Kuhn, Paul, and Chiarito, Patrick T.: Shear Lag in Box Beams - Methods of Analysis and Experimental Investigations. NACA Rep. No. 739, 1942.
2. Duberg, John E.: Comparison of an Approximate and an Exact Method of Shear-Lag Analysis. NACA ARR No. 4A18, 1944.
3. Duncan, W. J. (with Appendix by H. L. Cox): Diffusion of Load in Certain Sheet-Stringer Combinations. R. & M. No. 1825, British A.R.C., 1938.
4. Goodey, W. J.: Stress Diffusion Problems. Aircraft Engineering, vol. XVIII, no. 213, Nov. 1946, pp. 385-389.
5. Hildebrand, Francis B.: The Exact Solution of Shear-Lag Problems in Flat Panels and Box Beams Assumed Rigid in the Transverse Direction. NACA TN No. 894, 1943.
6. Anon.: Stressed Skin Structures. Roy. Aero. Soc. Data Sheets 02.05, 1942.
7. Kuhn, Paul: A Recurrence Formula for Shear-Lag Problems. NACA TN No. 739, 1939.
8. Ebner, H., and Köller, H.: Über den Kraftverlauf in längs- und querversteiften Scheiben. Luftfahrtforschung, Bd.15, Lfg. 10/11, Oct. 10, 1938, pp. 527-542.
9. Köller, H.: Spannungsverlauf und mittragende Breite bei Lasteinleitung in orthotrope Blechscheiben. Bericht 119 der Lilienthal-Gesellschaft für Luftfahrtforschung, 1939, pp. 61-81.

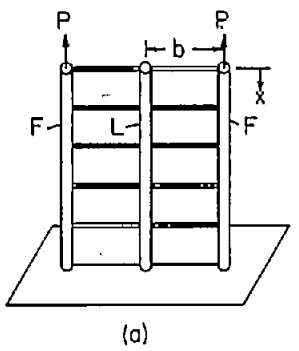

(a)

Figure 1.- Single-stringer panel.

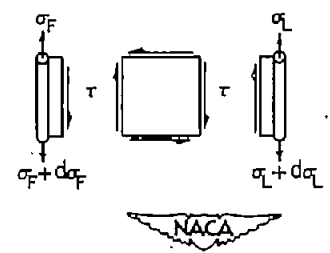

(b)

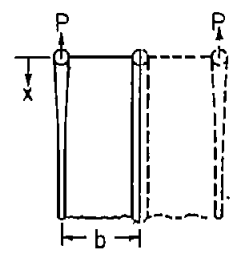

(a)

Figure 2.- Panel with constant-stress flange.

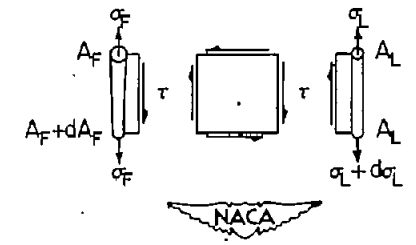

(b)

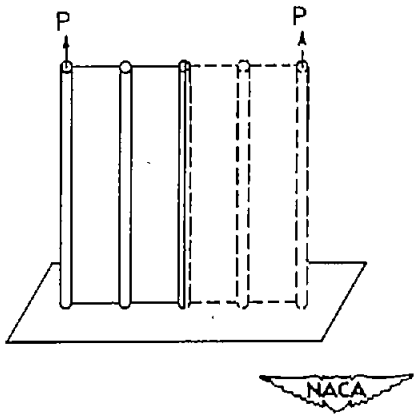
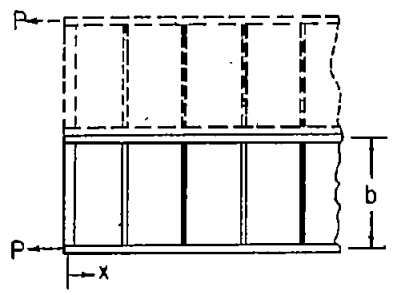
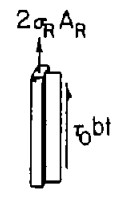

Figure 3.- Two-stringer panel.



(a)

Figure 4.- Panel with finite transverse stiffness.



(b)

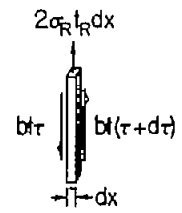

(c)

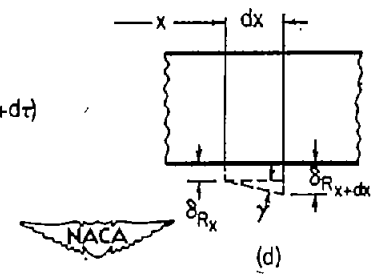

(d)

- "Rigorous" solution
- Substitute-single-stringer solution,  $b_s = 0.5 b_c$
- Substitute-single-stringer solution,  $b_s = .7 b_c$
- Substitute-single-stringer solution,  $b_s = .9 b_c$

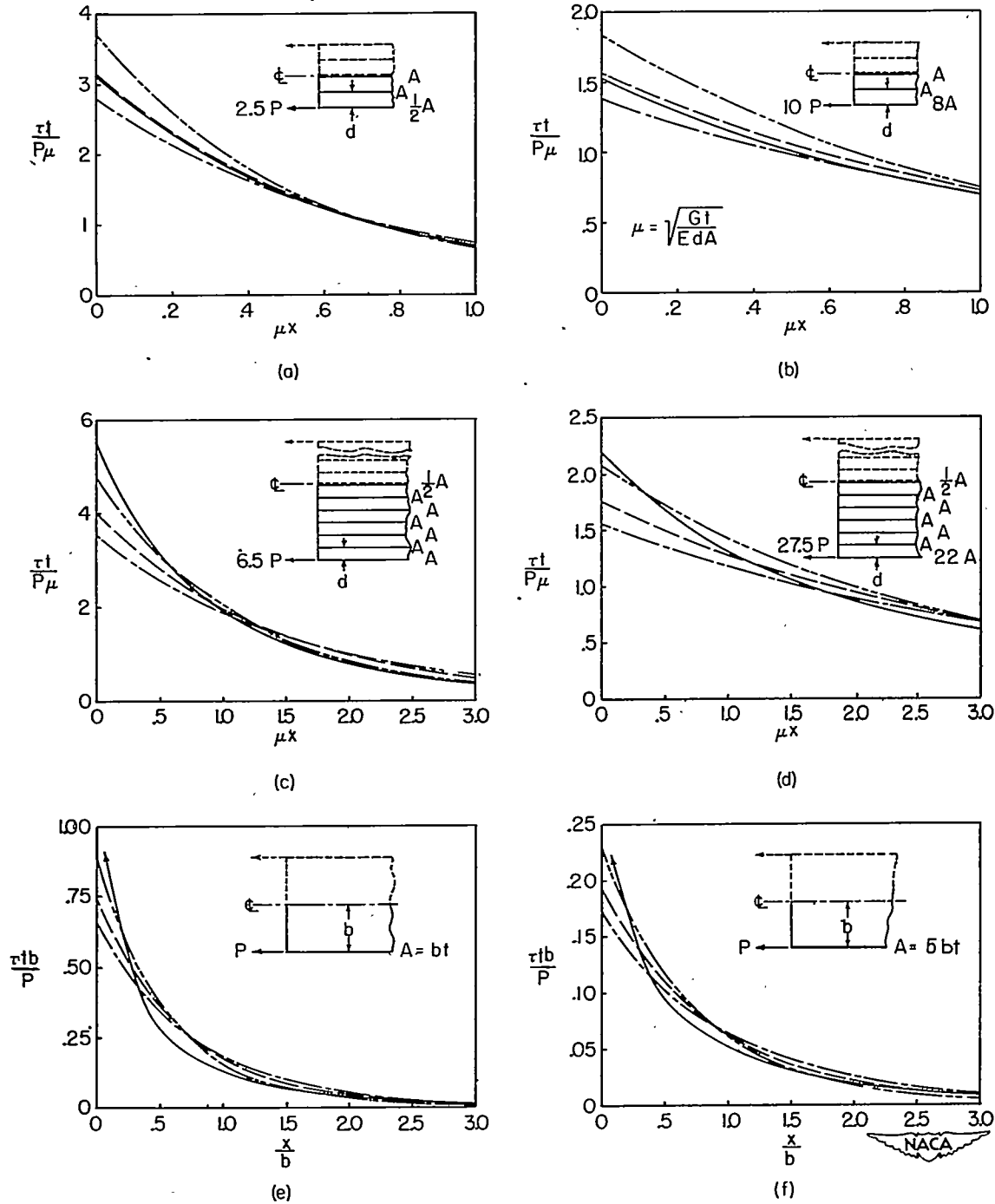

Figure 5.- Comparisons between solutions obtained by rigorous methods (on assumption of infinite transverse stiffness) and substitute-single-stringer method.

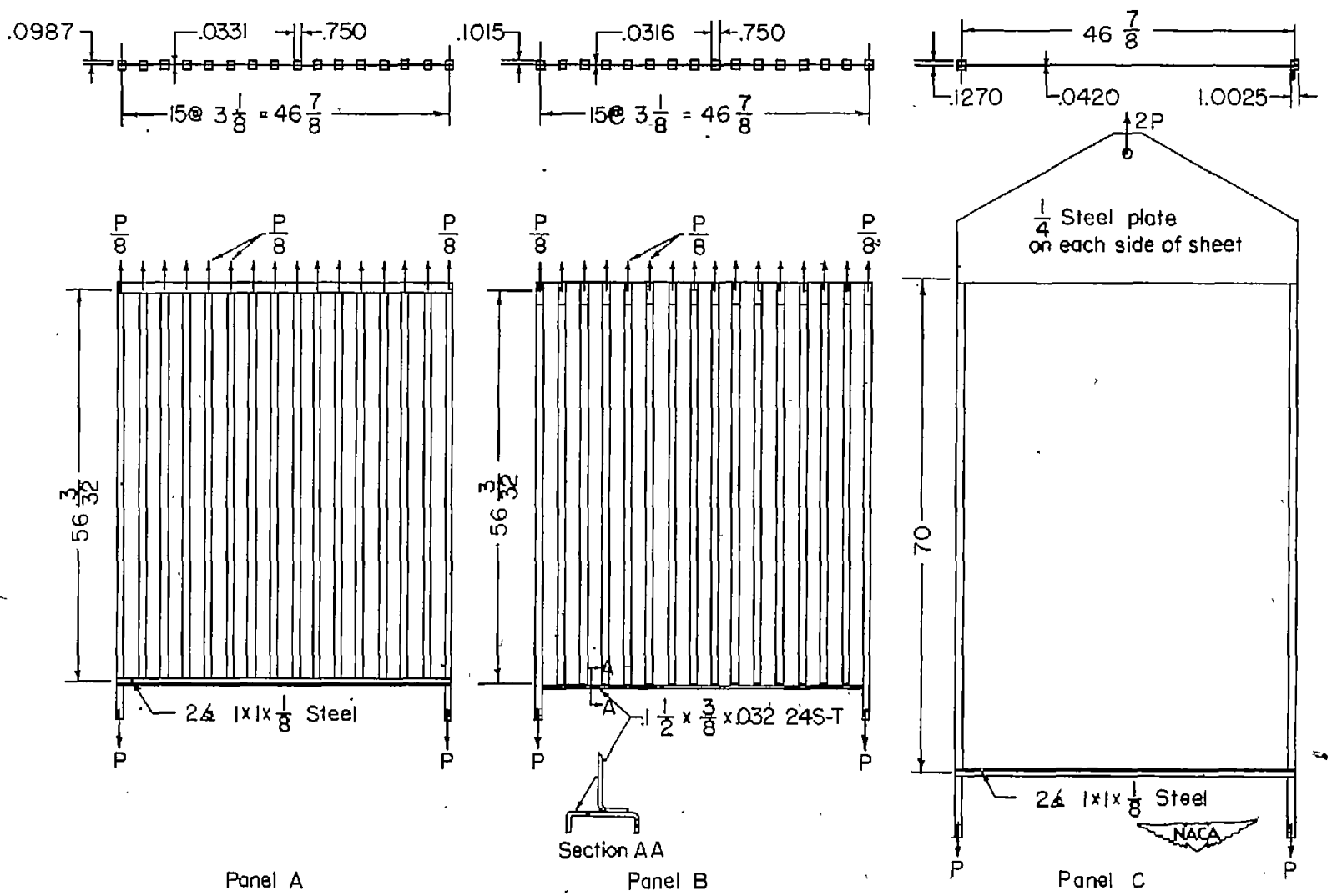

Figure 6.- Test panels of constant section. Material is 24S-T aluminum alloy unless otherwise noted.

NACA TR No. 1728

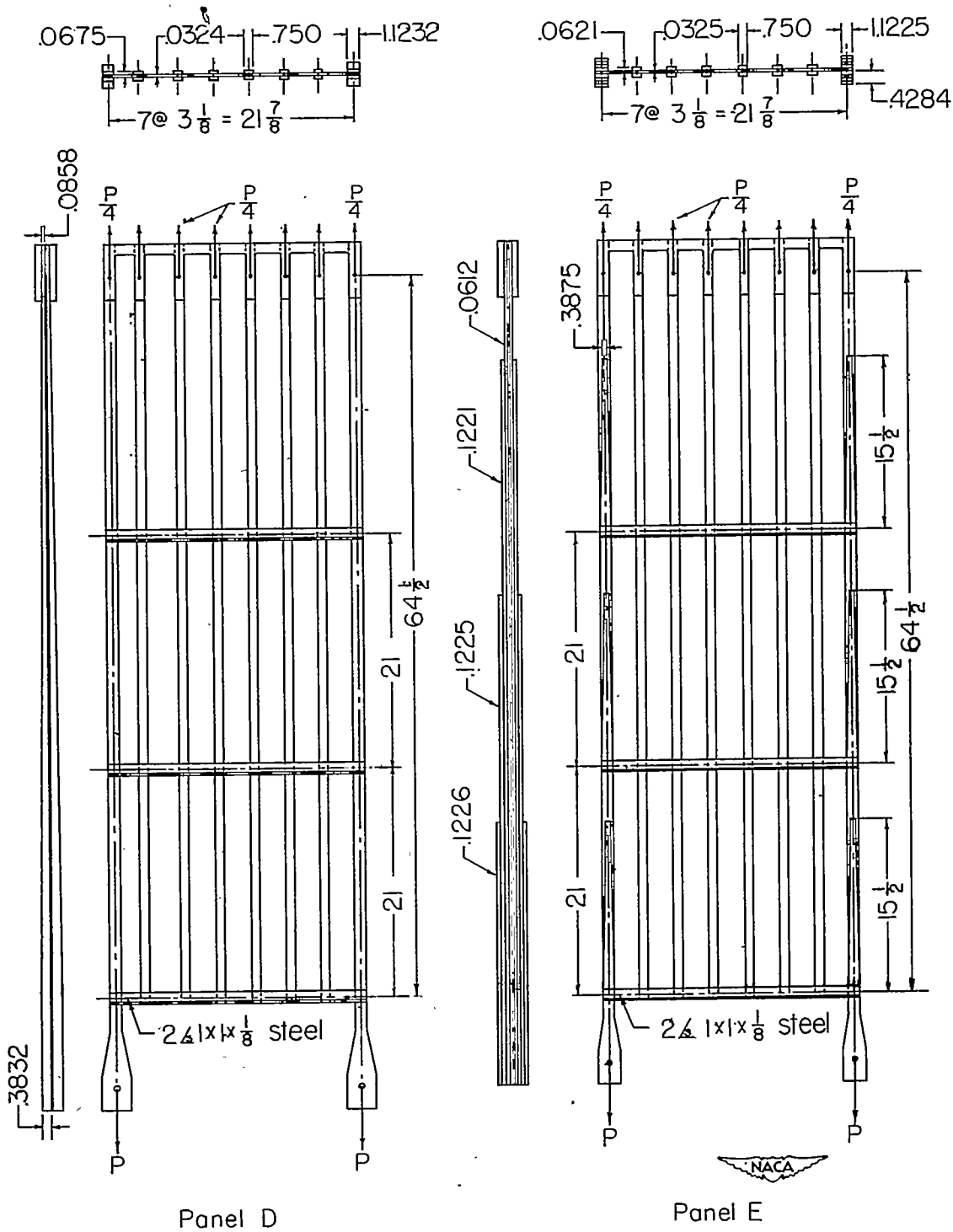

Figure 7.- Test panels with tapered flanges. Material is 24S-T aluminum alloy unless otherwise noted.

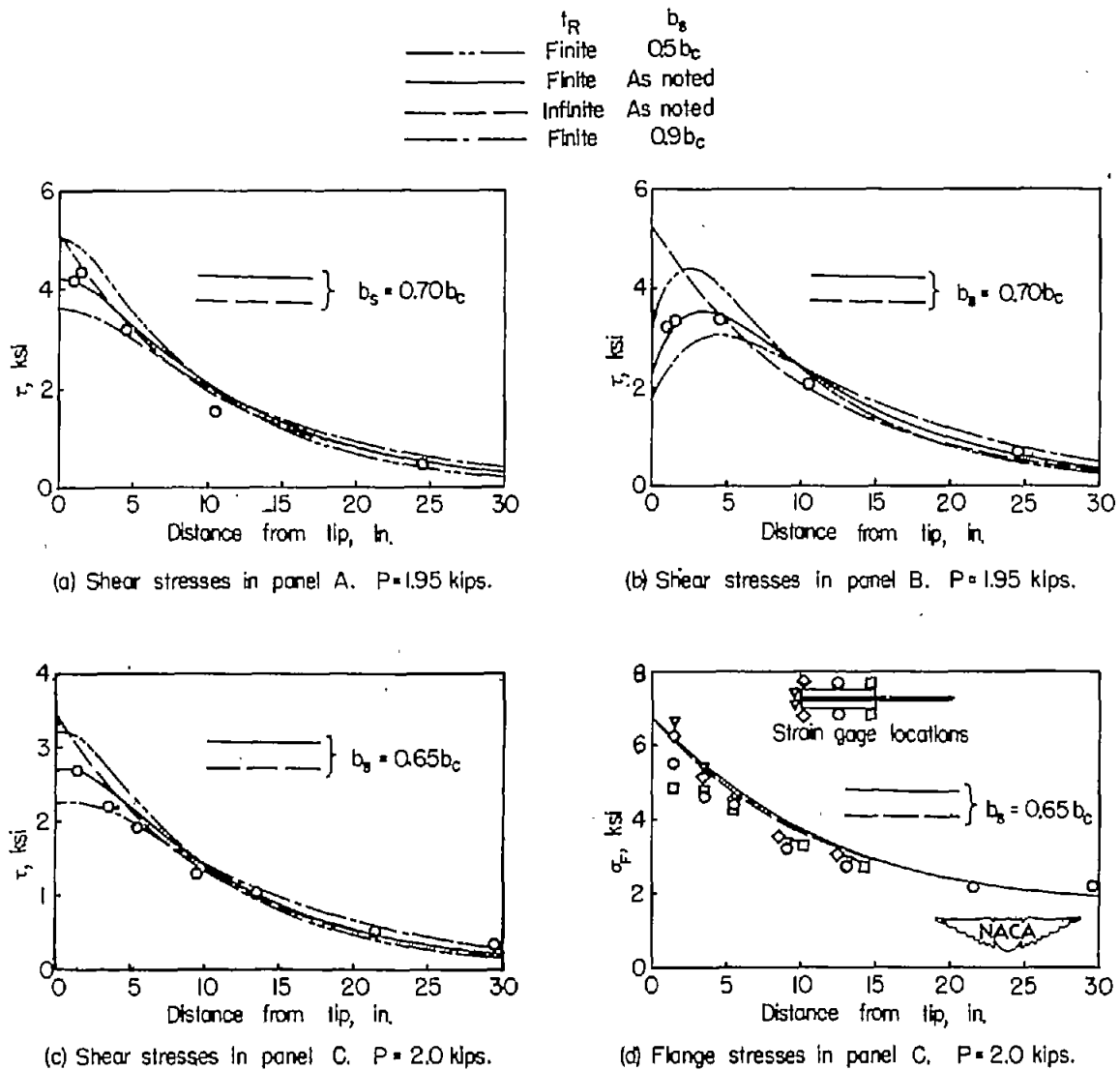
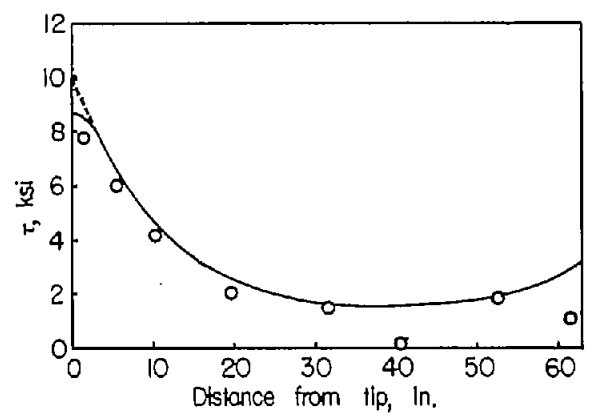
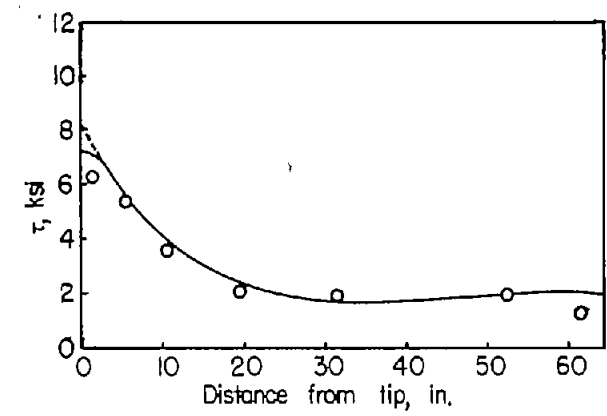

Figure 8: Experimental and calculated stresses in test panels of constant section.

○ Experimental stress  
 --- Stress calculated on assumption of infinite transverse stiffness  
 — Stress calculated on assumption of finite transverse stiffness



(a) Shear stresses in panel D.  $P = 7.66$  kips.



(b) Shear stresses in panel E.  $P = 7.5$  kips.

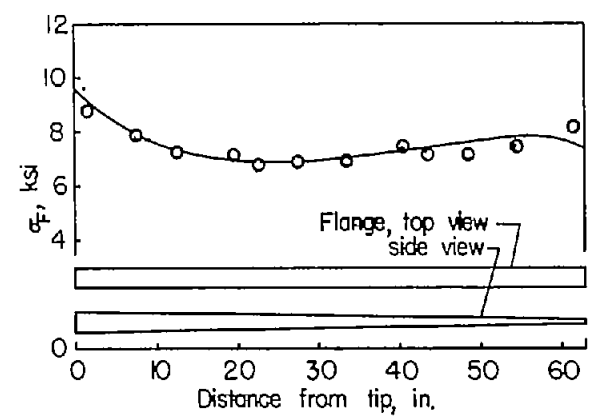

(c) Flange stresses in panel D.  $P = 7.66$  kips.

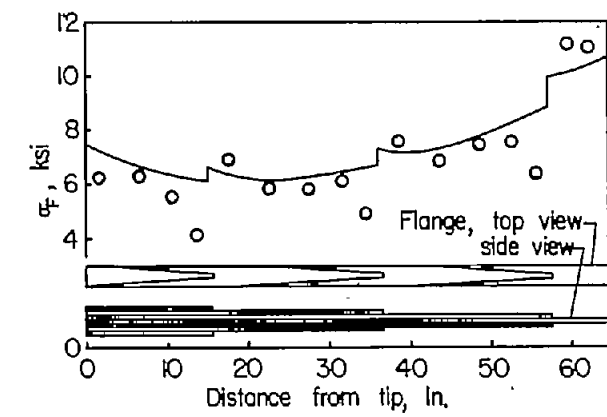

(d) Flange stresses in panel E.  $P = 7.5$  kips.

Figure 9.- Experimental and calculated stresses in test panels with tapered flanges.

