

APR 8 1948

UNCLASSIFIED

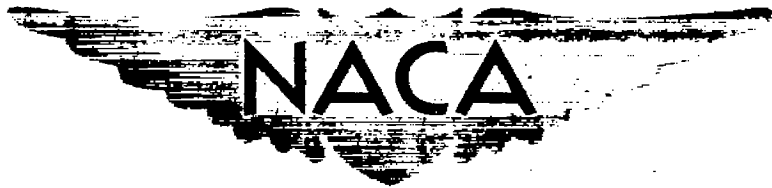

RESEARCH MEMORANDUM

INVESTIGATION OF THE I-40 JET-PROPULSION ENGINE
IN THE CLEVELAND ALTITUDE WIND TUNNEL
V - OPERATIONAL CHARACTERISTICS

By Richard L. Golladay and Stanley L. Gendler

Flight Propulsion Research Laboratory
Cleveland, Ohio

CLASSIFICATION CANCELLED

Author: J. W. Crowley Date: 12/14/54

2010521

By: JH-1-25-54 See: NACA

RF1947

This document contains classified information affecting the National Defense of the United States within the meaning of the Espionage Act, USC 501a and 502. Its transmission or the revelation of its contents in any manner to an unauthorized person is prohibited by law. Information so classified may be imparted only to persons in the military and naval services of the United States, appropriate civilian officers and employees of the Federal Government who have a legitimate interest therein, and to United States citizens of known loyalty and discretion who of necessity must be informed thereof.

NATIONAL ADVISORY COMMITTEE FOR AERONAUTICS

WASHINGTON
August 25, 1948

RESTRICTED

UNCLASSIFIED



NACA RM No. E8G02d

NATIONAL ADVISORY COMMITTEE FOR AERONAUTICS

RESEARCH MEMORANDUM

INVESTIGATION OF THE I-40 JET-PROPULSION ENGINE

IN THE CLEVELAND ALTITUDE WIND TUNNEL

V - OPERATIONAL CHARACTERISTICS

By Richard L. Golladay and Stanley L. Gendler

SUMMARY

An investigation has been conducted in the Cleveland altitude wind tunnel to determine the operational characteristics of the I-40 jet-propulsion engine over a range of pressure altitudes from 10,000 to 50,000 feet and ram pressure ratios from 1.00 to 1.76. Engine operational data were obtained with the engine in the standard configuration and with various modifications of the fuel system, the electrical system, and the combustion chambers. The effects of altitude and airspeed on operating speed range, starting, windmilling, acceleration, speed regulation, cooling, and vibration of the standard and modified engines were determined, and damage to parts was noted.

Maximum engine speed was obtainable at all altitudes and airspeeds with each fuel-control system investigated. The minimum idling speed was raised by increases in altitude and airspeed. The lowest minimum stable speeds were obtained with the standard configuration using 40-gallon nozzles with individual metering plugs.

The engine was started normally at altitudes as high as 20,000 feet with all of the fuel systems and ignition combinations except one. Ignition at 30,000 feet was difficult and, although successful ignition occurred, acceleration was slow and usually characterized by excessive tail-pipe temperature. During windmilling investigations of the engine equipped with the standard fuel system, the engine could not be started at ram pressure ratios of 1.1 to 1.7 at altitudes of 10,000, 20,000, and 30,000 feet.

When equipped with the production barometric and Monarch 40-gallon nozzles, the engine accelerated in 12 seconds from an engine speed of 6000 rpm to 11,000 rpm at 20,000 feet and an average tail-pipe temperature of 1100° F. At the same altitude and

temperature, all the engine configurations had approximately the same rate of acceleration. The Woodward governor produced the safest accelerations, inasmuch as it could be adjusted to automatically prevent acceleration blow-out.

The engine speed was held constant by the Woodward governor and the Edwards regulator during simulated dives and climbs at constant throttle position.

The bearing cooling system was satisfactory at all altitudes and airspeeds. The engines operated without serious failure, although the exhaust cone, the tail pipe, and the airplane fuselage were damaged during altitude starts.

INTRODUCTION

Performance and operational characteristics of the I-40 jet-propulsion engine installed in an airplane fuselage have been investigated in the Cleveland altitude wind tunnel. Performance characteristics of the engine and its component parts are given in references 1 to 4.

The operational characteristics of three I-40 engines in 17 configurations are presented herein. The engine fuel systems, electrical systems, and combustion chambers were modified in an effort to improve the operational characteristics. The effects of altitude, free-stream impact pressure (or airspeed), configuration, tail-pipe temperature, and fuel on operating speed range, starting, windmilling, acceleration, speed regulation, cooling, and vibration of the standard and modified engines were determined. Engine operating time between overhauls is given and parts failures are described.

Two inlet configurations were used on the airplane. During most of the operational runs, air was taken from the tunnel test section through the normal inlet ducts of the airplane. Windmilling and cooling-air-flow data were obtained with the air introduced into the inlet ducts through a ram pipe from the tunnel make-up air system.

The investigation was conducted over a range of pressure altitudes from 10,000 to 50,000 feet and at ram pressure ratios from 1.00 to 1.76 with approximate corresponding standard inlet-air temperatures.

DESCRIPTION OF ENGINE AND INSTALLATION

784

The I-40-3 jet-propulsion engine is rated at 3750 pounds static thrust at an engine speed of 11,500 rpm at sea level with an air flow of approximately 75 pounds per second and a fuel flow of 4400 pounds per hour. The length of the engine (excluding the tail pipe) is $102\frac{7}{8}$ inches, the maximum diameter is 48 inches, and the total weight is 1850 pounds. The engine consists of a double-inlet centrifugal compressor, 14 combustion chambers, and a single-stage impulse turbine. A detailed description is given in reference 1.

The engine was installed in an airplane fuselage mounted in the 20-foot-diameter test section of the Cleveland altitude wind tunnel (fig. 1). Air entered the airplane through inlets at both sides of the fuselage and flowed through ducts into a plenum chamber surrounding the compressor section of the engine.

Two inlet configurations were used on the airplane. During most of the operational investigations, air was taken from the tunnel test section through the normal inlet ducts of the airplane. When windmilling and cooling-air-flow data were taken, air from the tunnel make-up air system was introduced into the inlet ducts through a ram pipe (fig. 2). Pressure in the ram pipe could be varied from tunnel pressure to approximately sea-level pressure.

The airplane installation included a tail pipe 93.3 inches in length, which tapered uniformly from a 21-inch diameter at the exhaust-cone outlet to a 19-inch diameter at the tail-pipe outlet.

PROCEDURE AND INSTRUMENTATION

Investigations were conducted over a range of pressure altitudes from 10,000 to 50,000 feet with approximate corresponding standard air temperatures. When the normal inlet ducts were used, the free-stream impact pressure was maintained at a value of 40, 80, or 130 pounds per square foot; when air was introduced into the inlet ducts through the ram pipe, the ram pressure ratio was varied from approximately 1.05 to 1.76, which correspond to flight Mach numbers from about 0.26 to 0.94. Ram pressure ratio is defined as the ratio of the compressor-inlet total pressure to the free-stream static pressure.

With one configuration, gasoline (AN-F-28, grade 100/130) was used as well as kerosene. All other configurations were run with kerosene.

Extensive instrumentation was installed on the engine for measuring temperatures and pressures of the air and the gases at several stations (fig. 3). The fuel pressures presented were measured by gages vented to the tunnel pressure. During starting and accelerations, the engine control panel was photographed on motion-picture film to obtain a continuous record of pressures, temperatures, engine speed, and time. A vibration meter was used to indicate engine vibration. Three vibration pickups transmitted axial, transverse, and vertical vibration at the right trunnion support and a fourth pickup transmitted vertical vibration at the front support.

ENGINE CONFIGURATIONS

Seventeen configurations of three I-40 engines, varying in fuel system, electrical system, and combustion chamber, were investigated. The various combinations of engine accessories for each configuration are summarized in table I.

Fuel-System Components

The various fuel systems (figs. 4 to 9) differed in nozzles, regulators, and auxiliary starting systems.

Nozzles. - The Monarch nozzle (fig. 10(a)) is a single-flow spray nozzle. The two sets of tips that were used on this nozzle have a rated capacity of 30 and 40 gallons per hour and 60° and 80° spray angles, respectively, at a pressure drop of 100 pounds per square inch. The 40-gallon nozzles were fitted with individual metering plugs to equalize the flow.

Duplex nozzles, set 1 flared, were used (fig. 10(b)). This type of nozzle was developed to provide a satisfactory spray pattern over a wide range of fuel flow. The orifices of these nozzles have large flares and two sets of internal ports. A spring-loaded flow divider located upstream of the fuel manifolds allowed flow to only the small ports at low fuel flows and to both large and small ports at high fuel flows. At a pressure drop of 100 pounds per square inch, the capacity of the nozzles operating on only small ports is rated at 9 gallons per hour and operating on both sets of ports, at 45 gallons per hour.

784

Regulators. - The fuel regulators used in these configurations - the standard I-40 "barometric," the Syracuse modification, the Edwards regulator, and the Woodward governor - are described in detail in the appendix.

Auxiliary starting systems. - An accumulator and an electrically driven fuel pump were tried to improve the fuel spray during starting, inasmuch as the main and starting fuel pumps provided insufficient fuel pressure at starting speeds.

The accumulator is a chamber divided into two parts by a flexible diaphragm. One part is filled with high-pressure air and the other is connected to the fuel system across the throttle, as shown in figures 4, 5, and 8. The accumulator is filled with high-pressure fuel by the starting fuel pump, the throttle is then opened, and the fuel lines fill. Next the accumulator is opened and fuel is forced at high pressure to the nozzles for a few seconds, which should be long enough to light the burners.

An electrically driven main fuel pump from an I-16 engine was also used to supply high-pressure fuel for starting (figs. 6, 7, and 9). This pump has an advantage over the accumulator in that it can serve as an emergency fuel supply in the event of failure of the main fuel pump.

Fuel Systems

In the standard, or production, fuel system of configurations 1 to 7 (fig. 4) fuel is supplied to Monarch 40-gallon nozzles from a common fuel manifold at pressures ranging from 10 to 180 pounds per square inch, depending on engine speed and altitude. The main fuel pump is a positive-displacement pump driven by the engine. The starting fuel pump is driven by the starter gear and provides additional fuel during the starting period of the engine. Fuel flow is regulated by three controls: a barometric, a governor, and a manual control. The barometric and the governor bypass the fuel from the high-pressure line between the fuel pump and the nozzles back to the pump inlet. The barometric maintains a constant engine speed for a given throttle setting regardless of changes in altitude and airspeed. The governor limits the maximum engine speed to 11,500 rpm. The manual control consists of a poppet-type shut-off valve, which is closed to stop the engine, and a sliding-cylinder throttling valve, which is set by the pilot for the desired speed. An accumulator was used with configurations 6 and 7 to provide high-pressure starting spray.

The standard fuel system was altered slightly in configuration 8. The Monarch 40-gallon nozzle tips were replaced by 30-gallon tips, and the metering plugs were removed from the nozzle body. The starting fuel pump was omitted and the accumulator and a metering valve were added, as shown in figure 5.

Configuration 9 incorporated duplex fuel nozzles, a flow divider, and a Syracuse control system (fig. 6). The barometric of the Syracuse control system is a standard I-40 barometric slightly modified for use with duplex nozzles and a flow divider. The Syracuse governor includes a specially hardened pilot valve and liner, and the valve is designed with a shorter length to reduce frictional hysteresis. A single-lever control valve incorporates stopcock and throttle through a single control linkage. The throttle ports are designed to give a generally linear relation of thrust to throttle position. An auxiliary electrically driven fuel pump was used for starting. No engine-driven starting pump was included.

The fuel systems of configurations 10 and 11 consisted of an Edwards regulator with a Sundstrand pump, a flow divider, and duplex fuel nozzles (fig. 7). Configuration 11 also incorporated the electrically driven auxiliary fuel pump, and orifices were inserted in the variable-control oil line and small-port line. The Edwards control system differs basically from the standard fuel system in that it contains a variable-speed governor instead of an overspeed governor. Several functions are combined into one oil pressure, which operates the Sundstrand pump relay. A single-lever control operates the stopcock and the regulator manual control. This manual control regulates variable-control oil pressure as a function of throttle position. The governor controls the engine speed between a given lower limit and maximum speed. This lower limit was 9000 rpm in configuration 10 and was changed to 6500 rpm in configuration 11.

A Woodward governor was used with Monarch 30-gallon fuel nozzles and an accumulator in configuration 12 (fig. 8) and with duplex nozzles and the electrically driven auxiliary fuel pump in configurations 13 to 17 (fig. 9). The Woodward governor is a speed-sensitive fuel control designed to maintain constant engine speed regardless of flight conditions. The governor consists of the main fuel pump, the main governor, the overspeed governor, the differential relief valve for bypassing excess fuel, and the speed-adjustment and manual-control valve. The manual-control valve is operated through the first 30° of throttle travel; through the next 60°, any governor speed setting can be selected. The rate of

784

acceleration is set by the governor regardless of the rapidity of throttle movement and can be varied by changing the amount of leakage through a dashpot by adjusting various-sized pins (fig. 11). A variable orifice connects the two faces of the dashpot piston and accelerates the rate of speed adjustment in the high-speed ranges. With this governor the throttle can be moved to the desired position and the engine speed will be automatically adjusted.

Electrical Systems

Starters. - The standard I-40 starter used in configurations 1 to 8, 10, and 12 is a four-pole, compensated, commutating-type motor rated at 17 volts, 300 amperes, and 8000 rpm.

The combination starter-generator used in configurations 9, 11, and 13 to 17 was designed to give three long starts in succession at sea level without overheating. It also has a higher free-running speed than the standard starter and continues to supply torque up to about 3000 rpm. The cranking speed is the same as for the standard starter (about 1000 rpm).

Types of ignition. - The standard I-40 ignition system used in configurations 1 and 5 includes a 24-volt, direct-current ignition boost coil. The primary and secondary coils are wound on a soft-iron core, and a vibrating contact operates by and in the primary circuit. The booster-coil installation is unshielded; 5-millimeter unshielded ignition cables 24 inches long connect the coils to the spark plugs.

The 400-cycle ignition transformer used in configuration 2 has a primary-voltage rating of 26 volts, a secondary-voltage rating of not less than 8000 volts when the circuit is open, and 4500 volts at 4 milliamperes. The transformer is provided with a magnetic shunt so adjusted that the short-circuit secondary current is from 7 to 10 milliamperes. Unshielded 5-millimeter secondary leads 54 inches long were used.

The "buzz box" used in configuration 3 consists of a vibrator and a 5000-ohm magneto coil. The magneto coil has a copper-wound, 5000-ohm secondary winding and a 3/16-inch magnetic iron yoke, which results in a secondary inductance of 18 henries at 1000 cycles. The supply voltage is 24 volts direct current and the output open-circuit peak voltage is 19,000 volts. The spark plugs were connected by 5-millimeter secondary leads in 7-millimeter shielded conduit 24 inches long.

The experimental dual magneto used in configurations 4 and 7 is a four-spark magneto of the inductor type driven at 0.6685 engine speed. The magneto was mounted on the generator pad; the spark plugs were connected by 7-millimeter aircraft ignition leads in a shielded conduit $4\frac{1}{2}$ feet long.

An experimental 60-cycle, 12,000-volt ignition transformer was used in configurations 6, 8, 10, and 12 to 17 to furnish 12,000 volts to the spark plugs.

Two shielded ignition boost coils, similar to those used in configurations 1 and 5, were used in configurations 9 and 11.

Spark plugs. - Four adaptations, types A to D (fig. 12), of Champion D8 spark plugs were made for the investigation. Sizes of parts and positions of the holes were varied as shown in figure 12.

For configuration 6, one spark plug was installed in burner 3 and one in burner 10. For all other configurations, one spark plug was installed in burner 2 and one in burner 9.

In configurations 6 and 7, the type B spark plugs in burners 3 and 2, respectively, were placed with the hole downstream; the spark plugs in burners 10 and 9 were placed with the hole upstream.

Combustion Chambers

The standard type C combustion chambers (fig. 13) were used in configurations 1 to 8, 10, and 12. For configurations 9, 11, and 13 to 17, type E combustion chambers (fig. 13) were used. The domes of type E combustion chambers differ from the conventional type C domes as follows:

1. Auxiliary air louvers are provided near the periphery instead of near the center of the dome to reduce deposition of carbon.
2. The dome is either an integral welded assembly or a close slip fit with the liner instead of being bracketed to the combustion chamber, thus providing a uniform annular air slot in

the clearance between the two parts. This clearance is provided by seven depressions on the liner.

A detailed description of these combustion chambers is included in reference 4.

RESULTS AND DISCUSSION

Operating Range

The effect of pressure altitude on the operating range of the I-40 engine with various fuel-system configurations is shown in figures 14 to 18.

Investigations at pressure altitudes up to 50,000 feet and ram pressure ratios equivalent to airspeeds from 0 to 650 miles per hour indicated that the maximum engine speed was governed only by the design limitation of 11,500 rpm (fig. 14). The minimum stable and minimum idling engine speeds increased with altitude. The minimum stable engine speed is defined as the minimum speed at which burning occurs in all combustion chambers and from which acceleration could be effected, although at a very low rate. The minimum idling engine speed is defined as the minimum speed at which one combustion chamber blows out during a very slow deceleration. One of the top combustion chambers was always first to blow out, which was apparently caused by the difference in static head between the top and the bottom of the fuel manifold. In a few instances, minimum-idling-speed data were taken before any burners had blown out owing to indications based on experience that the engine was on the verge of complete blow-out. Attempts to accelerate from these minimum idling speeds frequently resulted in complete engine blow-out; the area in figure 14 between the minimum-stable and the maximum-engine-speed curves is therefore considered the safe operating range. Caution is required at altitude to accelerate even from these minimum stable engine speeds.

Inasmuch as a reasonably accurate value of the minimum idling speed is more readily determined than the value of minimum stable engine speed, the idling speed is the parameter chosen in observing the effect of variations in (1) type of fuel regulator, (2) type of burner nozzle, (3) type of fuel, and (4) free-stream impact pressure on operating range.

All the fuel-control systems allowed a reduction in fuel-manifold pressure at all altitudes to a point where combustion

blow-out occurred. The minimum idling speeds for configurations 9, 11, and 13 equipped with the Syracuse barometric, the Edwards regulator, and the Woodward governor, respectively, are shown in figure 15(a). Inasmuch as the fuel pressure could be slowly reduced to the minimum speed point with all three fuel regulators and inasmuch as all three configurations included the same set of nozzles, the fuel regulator should have had no effect on the minimum idling speed of the engine at each altitude. The data in figure 15(a) show that the maximum difference in minimum idling speed was 1000 rpm at an altitude of 20,000 feet. The fuel flow required to operate the engine at minimum idling speed with each of the fuel regulators is shown in figure 15(b).

The Monarch nozzles with 40-gallon tips used in configurations 1 to 7 gave the lowest idling speed at all altitudes of any configuration investigated. (See figs. 15 to 17.) Only the nozzles with 40-gallon tips had individual metering plugs, which produced a relatively high fuel-manifold pressure at low fuel flows and minimized the effect of static head in the manifold.

The Monarch 30-gallon nozzles gave a lower minimum idling speed than the duplex nozzles (fig. 16), although both nozzles were investigated without individual metering plugs. Apparently the Monarch 30-gallon tips provide a better spray pattern at low pressures than the small slots of the duplex nozzles.

The use of gasoline instead of kerosene in configuration 9 (fig. 17) lowered the minimum idling speed 1200 rpm at 30,000 feet and 1500 rpm at 40,000 feet, but gave no improvement at 10,000 or 20,000 feet. Gasoline has a higher volatility than kerosene, which apparently allows combustion to continue at a lower nozzle pressure drop and poorer spray pattern with gasoline than with kerosene at high altitudes.

Increasing the free-stream impact pressure, or airspeed, for a given throttle position, resulted in higher minimum idling engine speeds at all altitudes (fig. 18). A reduction in fuel flow to lower the engine speed so impaired the spray characteristics of the fuel nozzles that one of the combustion chambers blew out. Also shown in figure 18 are the characteristic fuel-manifold pressure, throttle position, air flow, fuel flow, fuel-air ratio, and tail-pipe temperature for each corresponding minimum idling speed.

Starting

The following method was found most satisfactory for starting the I-40 engine with the standard fuel system. By means of a

784

starter the engine speed was raised to approximately 1000 rpm. With the throttle one-half to three-fourths open, the ignition was turned on and the stopcock was opened. When the fuel-manifold pressure reached approximately 70 pounds per square inch, the burners ignited; the ignition was turned off and the throttle was retarded until the tail-pipe temperature had dropped to approximately 1500° F. The throttle was then gradually opened to maintain constant tail-pipe temperature during the acceleration. The starter was used until the engine speed reached 3500 rpm. This technique was employed at static conditions and low pressure altitude but was changed slightly in order to obtain successful starts at high altitudes and airspeeds. Changes in engine configuration also required slight variations.

When the engine was started at pressure altitudes above 10,000 feet with some configurations, fuel pressures high enough to give a good starting spray were sometimes unobtainable. Configurations 6 to 9 and 11 to 17 included auxiliary fuel systems that were used to momentarily boost fuel pressure for starting. Various spark plugs, ignition coils, fuel controls, and nozzles (table I) were also used in an effort to improve the starting characteristics of the engine. The results are shown in table II.

Configurations 1 to 4 were investigated in an effort to find a satisfactory type of ignition. Most of the starts with these configurations were made at a free-stream impact pressure of 25 pounds per square foot, fuel-manifold pressures from 70 to 90 pounds per square inch, and maximum tail-pipe temperatures from 1750° to 2000° F. (See table II.) No successful starts were made above a simulated altitude of 20,000 feet with any of the four systems. A start was made at 20,000 feet with configuration 1. The ignition boost coils used in the standard configuration were burned out during an attempt to start at 38,000 feet. With the 400-cycle transformer (configuration 2), the engine could not be started at altitudes above 10,000 feet. Inconclusive data were obtained for configurations 3 and 4 because the inner cross-ignition tubes fell into the combustion chambers.

Effects of accumulator injection and free-stream impact pressure were observed with configuration 6, which incorporated the 60-cycle, 12,000-volt transformer. During these investigations, the accumulator was opened when the fuel-manifold pressure reached 20 pounds per square inch and the free-stream impact pressure was maintained at either 40 or 80 pounds per square foot. Only at an altitude of 30,000 feet do the data conclusively show that the accumulator appreciably aided starting. In order to be effective, the accumulator had to be charged fully and then discharged at a

time when the nozzles would receive the full effect of the pressure boost. This requirement was sometimes not fulfilled. When the accumulator was used at an altitude of 30,000 feet and a free-stream impact pressure of 40 pounds per square foot, usually only three or four burners lit until the accumulator was discharged three or four times; then more burners lit and the engine started to accelerate slowly. As the acceleration proceeded, the tail-pipe temperature became excessive (over 2000° F) and at an engine speed of about 3500 rpm no further acceleration was possible. The free-stream impact pressure seemed to have little effect on the starting characteristics.

Results with configuration 7 are also inconclusive as to the effect of the accumulator and of changes in impact pressure. These starts were made with the D-4 dual magneto, however, whereas the starts with configuration 6 were made with the transformer. With the magneto, the ignition time was sometimes slightly shortened, but the engine was not successfully ignited at an altitude of 30,000 feet. One start was made at 20,000 feet with a combination of the transformer and the magneto, and the accumulator (configurations 6 and 7). No improvement over the starts with a single ignition system was noted.

Configuration 8 was the standard barometric used with Monarch 30-gallon nozzles and a metering valve; the barometric was used without an engine-driven starting fuel pump for the first time. Starting the engine was difficult at sea level and impossible at altitude because the main fuel pump provided a very low fuel pressure at starting speeds. (None of these starts are listed in table II.) In order to get a satisfactory start, a bypass line was installed around the metering valve and an accumulator was added to the system. Starts were then made at an altitude of 10,000 feet with or without the accumulator, although ignition was more rapid with the accumulator. Starts at 20,000 feet were possible only with the boost of the accumulator.

Starts with the Syracuse fuel system (configuration 9) were tried with both gasoline and kerosene. The limited data indicate that gasoline and kerosene ignited with equal ease, but a faster acceleration at lower tail-pipe temperatures resulted with gasoline. Starts were made at altitudes of 10,000 and 20,000 feet with kerosene and at 10,000, 20,000, and 25,000 feet with gasoline. An attempt to start the engine at an altitude of 30,000 feet with gasoline was unsuccessful. The electrically driven fuel pump was used in an effort to ignite the burners, but the few burners that did ignite were insufficient to accelerate the engine.

784

In the next investigation a change was made from the barometric fuel control and Monarch nozzles to the Edwards regulator and duplex nozzles (configuration 10). Cooler and quicker starts with little or no flame in the tail pipe at the start were anticipated with the duplex nozzles, because the small ports of the duplex nozzle were designed to give a good spray at the low fuel flows encountered in starting. During a typical start with this system at an altitude of 20,000 feet, however, a yellow flame 20 feet long was emitted from the tail pipe at ignition. Thus the duplex nozzles used with the Edwards regulator apparently did not prevent long flames during altitude starts. No starting-fuel-pump system was used and the length of time to ignite the burners ranged from about 25 to 30 seconds at altitudes as high as 25,000 feet. Acceleration to an engine speed of 4000 rpm required approximately 70 seconds at altitudes of 10,000 and 15,000 feet, which was no improvement over accelerations with the barometric.

The Edwards regulator was investigated for a second time in configuration 11. Several changes were made in the regulator. Because of the use of type E domes, which incorporate spark-plug locations suitable only for high-pressure starting spray, the engine could be started only when the electrically driven auxiliary fuel pump was used. Ignition was accomplished in approximately 30 seconds at altitudes of 10,000 and 20,000 feet, and accelerations to an engine speed of 6000 rpm were made in an average time of 75 seconds at an altitude of 10,000 feet and 90 seconds at 20,000 feet. Tail-pipe temperatures ranged from 1500° to 2000° F.

Configuration 12 used the Woodward governor with Monarch 30-gallon nozzles. The engine was started with the throttle full open. After ignition it was retarded to about one-fourth throttle. The fuel-pump discharge pressure with throttle closed was between 50 and 60 pounds per square inch at altitudes up to 20,000 feet. The fuel-pump discharge pressure at ignition was 20 pounds per square inch at an altitude of 5000 feet and 10 pounds per square inch at 10,000 and 20,000 feet. No starts were attempted above 20,000 feet because of excessive tail-pipe temperatures during acceleration immediately after ignition.

Five configurations (13 to 17) of the engine equipped with the Woodward governor, duplex nozzles, and the 60-cycle, 12,000-volt ignition transformer were investigated. Changes were made in the governor in order to vary the rate of acceleration. These changes had no material effect on the starting characteristics of the engine; therefore starts were made only with configurations 13 and 14. Configuration 13 had the type A spark plug and configuration 14

was equipped with the type D spark plug, which was designed to suit the wide spray angle of the duplex nozzle. The unit was ignited at altitudes of 10,000 and 20,000 feet and accelerated to an engine speed of 4000 rpm in approximately 80 seconds at a maximum tail-pipe temperature of 1750° F. The only successful start at an altitude of 30,000 feet during the entire investigation was made with configuration 14 without the electrically driven fuel pump. The burners ignited in 29 seconds and acceleration to an engine speed of 6000 rpm was accomplished in 2 minutes. The tail-pipe temperature, however, exceeded 2000° F.

784

Windmilling Starting

A study of the variation of engine windmilling speed, fuel-pump discharge pressure, and air flow with true airspeed and altitude is important to the design of satisfactory fuel and ignition systems for starting the I-40 engine at altitude. The engine windmilling speed for all configurations was independent of altitude and increased almost linearly with true airspeed, as shown in figure 19. This equivalent true airspeed is based on a 100-percent free-stream total-pressure recovery at the compressor inlet.

With configurations 1 to 7, fuel-pump discharge pressure (fig. 20) decreased as altitude increased because fuel was bypassed by the barometric fuel control. Fuel pressure increased with true airspeed as a result of increased windmilling speed and the increased ram pressure acting on the barometric, which was vented to the plenum chamber. At a true airspeed of 400 miles per hour, the fuel pressure was 60 pounds per square inch gage at an altitude of 40,000 feet and 350 pounds per square inch gage at 10,000 feet.

As indicated in figure 21 for a given corrected engine speed $N/\sqrt{\theta}$, the corrected air flow $W_p \sqrt{\theta/\delta}$ is greater when the engine is windmilling than when it is operating. These data, which were obtained at several altitudes, were generalized to NACA standard conditions at sea level by means of the correction factors θ and δ for the purpose of comparison. The factor θ is defined as the ratio of compressor-inlet total temperature at altitude to NACA standard temperature at sea level. The factor δ is defined as the ratio of total pressure at altitude to NACA standard pressure at sea level. These correction factors were found to give good results. (See reference 1.)

With the engine windmilling, attempts to start without the starter were made at altitudes of 10,000, 20,000, and 30,000 feet

and ram pressure ratios of 1.1 to 1.7, true airspeeds from 266 to 676 miles per hour. (See table III.) The fuel could not be ignited at any of these flight conditions. The engine was equipped with the standard barometric and Monarch 40-gallon nozzles (configuration 5). Several factors probably contributed to these unsuccessful attempts to start. The high air flow created a low fuel-air ratio and tended to blow the fuel away from the spark plug. The low fuel pressure causes a poor spray pattern. This spray pattern could be improved by using a high-pressure, electrically driven fuel pump or by bypassing the barometric during the starting cycle.

Acceleration

The acceleration characteristics of the engine with various fuel systems were investigated to determine which system would give the fastest acceleration without combustion blow-out or excessive tail-pipe temperature. The effect of altitude and tail-pipe temperature on acceleration was also observed. The free-stream impact pressure was constant at 40 pounds per square foot.

An effort was made to maintain a constant tail-pipe temperature during most of the accelerations, but constant temperatures were difficult to maintain with all the fuel systems. Although the temperature was relatively constant, one-fourth to one-half of the acceleration was finished before the desired temperature was reached. Quicker attainment of the desired tail-pipe temperature required a more rapid movement of the throttle and would have resulted in combustion blow-out. Many accelerations, particularly from low initial engine speeds and at high altitudes, ended in blow-out in the first part of the acceleration. When the Woodward governor was used (configurations 12 to 17), manual operation of the throttle gave only a limited control over the tail-pipe temperature and consequently over the acceleration rate. A preset automatic-acceleration device provided most of the control in the Woodward governor.

The acceleration data, which were recorded at various altitudes, were plotted using tail-pipe temperature as the basic parameter. The intersection of constant-temperature lines and the curves of constant initial engine speed were determined. Values taken from the points of intersection were then plotted with initial engine speed as the basic parameter.

Accelerations were made with the barometric and the 40-gallon nozzles (configurations 1 to 7) at altitudes up to 40,000 feet.

Figure 22(a) shows the effect of initial engine speed and altitude on the time to reach an engine speed of 11,000 rpm with an average tail-pipe temperature of 1100° F. At an altitude of 20,000 feet and an initial engine speed of 6000 rpm an acceleration was made in 12 seconds. The time to accelerate increases with increasing altitude inasmuch as the mass flow of air available for reaction on the turbine decreases and the inertia of the engine rotor is constant.

The effect of tail-pipe temperature on the rate of acceleration at an altitude of 30,000 feet is shown in figure 22(b). Similar results were found at other altitudes. The tail-pipe temperatures presented are the averages of the values obtained by photographing the instrument panel once every second during the acceleration. Increasing the average tail-pipe temperature and hence the energy and the velocity of the gases decreased the acceleration time. The effect of altitude and tail-pipe temperature was demonstrated throughout the investigation regardless of the type of nozzle or fuel control. (See figs. 22 to 27.)

A comparison of representative accelerations of two configurations with the Edwards regulator (configurations 10 and 11) is shown in figure 24. The comparison is made at altitudes of 10,000, 20,000, and 30,000 feet. For configuration 11, several changes were made to the fuel system used in configuration 10. An orifice was inserted in the variable-control oil line and a 0.099-inch orifice was inserted in the small-port line to limit the rate of change of fuel pressure, and the regulator altitude compensator was vented to compressor-discharge pressure. These changes were expected to improve fuel pressure at low flows, prevent deceleration blow-out, and prevent flooding during accelerations, but they had little or no effect on the acceleration time of the engine (fig. 24).

A comparison of accelerations made with the Woodward governor at an altitude of 10,000 feet and a maximum tail-pipe temperature of 1500° F is shown in figure 26. In these investigations two acceleration pins were used at various settings and two types of nozzle, Monarch 30-gallon and duplex. In configuration 17, the orifice in the small-port line (fig. 10) was removed. Configuration 12 with the Monarch 30-gallon nozzles and the acceleration pin fully in accelerated the most rapidly. However, a very rapid movement of the throttle with configurations 12 to 14 at altitudes of 30,000 and 40,000 feet results in burner blow-out, whereas in configurations 15 to 17, the acceleration rate permitted by the governor was so decreased that no burner blow-out was obtained under any acceleration conditions.

The engine equipped with the Syracuse control system accelerated slightly faster with gasoline than with kerosene at every altitude except 10,000 feet (fig. 27(a)). This faster acceleration is perhaps due to the fact that the gasoline vaporizes and burns faster than kerosene and therefore a larger percentage is burned ahead of the turbine during these engine operations. At an altitude of 20,000 feet, the engine accelerated faster with gasoline than with kerosene at all average tail-pipe temperatures (fig. 27(b)). However, the maximum rate of acceleration as limited by blow-out was lower with gasoline than with kerosene.

The time to accelerate from 6000 to 11,000 rpm at an altitude of 20,000 feet and an average tail-pipe temperature of 1100° F for several fuel-system configurations is tabulated in table IV. The maximum variation in acceleration time among the configurations was 4 seconds. At other altitudes and average tail-pipe temperatures there is some variation from the comparison shown, but the same general distribution is demonstrated. Acceleration time is mainly a function of altitude and average tail-pipe temperature, as indicated in table IV and figures 22 to 27.

The best fuel control for acceleration is one that can be adjusted to prevent acceleration blow-out and to automatically maintain the tail-pipe temperature just below the limit. Safe engine-speed changes would result in the minimum amount of time at each altitude. Of the fuel controls investigated, the Woodward governor, correctly adjusted, could best prevent acceleration blow-out. Once adjusted, however, the Woodward governor had the same acceleration rate at all altitudes; if set at sea level the rate of acceleration would therefore be too rapid at altitude and would probably cause blow-out.

Deceleration

Quick deceleration of the engine in flight with some fuel-control systems will result in combustion blow-out. The results in table V were obtained without encountering blow-out. The most rapid decelerations were made with the barometric, although decelerations with the Woodward governor were satisfactory. The Edwards regulator was unsuitable for decelerations because the fuel-pump output decreased sharply when the throttle was retarded and combustion blow-out resulted. The Edwards regulator was revised in an attempt to prevent combustion blow-out on accelerations and decelerations. An orifice was installed in the variable-control oil line to limit the rate of change of variable-control oil pressure and therefore of main fuel pressure, but the improvement was very slight.

Speed Regulation with Changes in Altitude

Simulated climbs and dives were made between altitudes of 10,000 and 40,000 feet. Because the "hysteresis" effect was very small, climbs and dives produced similar results; only the climbs, therefore, will be discussed (fig. 28). The climbs were made at an average rate of approximately 3500 feet per minute. Throughout the climb the engine-throttle position remained constant and the free-stream impact pressure was held at a value of approximately 40 pounds per square foot. No attempt was made to maintain standard atmospheric temperatures.

One function of the fuel control is to maintain constant engine speed at constant throttle position during changes in altitude. The barometric consists of a pressure-sensitive bellows or diaphragm that indirectly operates a fuel-regulating valve. As the altitude pressure changes, the fuel-manifold pressure is adjusted by the barometric to keep a constant speed. The barometric control and Syracuse modification investigated adjusted the manifold pressure insufficiently, however, and the engine speed advanced as much as 5000 rpm during climbs from altitudes of 10,000 to 40,000 feet (fig. 28). The Woodward governor and Edwards regulator are speed-sensitive controls; that is, regardless of operating conditions the control maintains a constant engine speed at a given throttle position. The fuel-pressure regulation is dependent on a variable-speed flyball governor. These two controls maintained very nearly constant speed during the climb by decreasing the fuel-manifold pressure, because less fuel is needed to maintain a given engine speed as the altitude increases.

Cooling

The I-40 bearing-cooling system was satisfactory at all engine conditions; the highest turbine-rear-bearing temperature of 235° F at an engine speed of 11,500 rpm (fig. 29) is well below the manufacturer's limit of 300° F. At this engine speed, the airspeed has no effect on the bearing temperature at airspeeds above 250 miles per hour. The temperature increases with decreasing airspeed from 250 miles per hour to static conditions. The effect of altitude (fig. 29) on the bearing temperature is negligible.

The cooling-air flow given in figure 30 is the sum of the air leaking past the engine baffle in the airplane and the air pumped past the bearing by the turbine-cooling-air fan. This total cooling-air flow cools the exhaust cone and tail pipe before discharging at the annulus between the tail pipe and fuselage.

Engine Vibration

The vibration of the I-40 engine at its points of support was measured during the investigation. The amplitudes of these vibrations for various pressure altitudes, ram pressure ratios, and engine speeds are given in table VI. The data show that altitude and ram pressure ratio had no apparent effect on the vibration and that the variation with engine speed is small. The maximum vibration of 0.0013 inch encountered in these investigations is small and well within the manufacturer's limit of 0.003 inch.

Engine Reliability

The three I-40 jet-propulsion engines gave satisfactory normal operation throughout the investigation without failure of major components such as compressor, turbine, or bearings. The total operating time of each engine and the elapsed time between overhauls are given in the following table:

Engine	Operating time before overhaul (hr)	Total oper- ating time (hr)
1	29.3 17.3 44.1	90.7
2	33.9 22.6 9.2	65.7
3	31.9	31.9

Replacement of cross-ignition tubes, combustion-chamber liners, exhaust cone, and spark plugs was sometimes necessary between overhauls.

Most of the damage to the exhaust cone occurred during starts at altitude. Several exhaust cones cracked and wrinkled owing to excessive tail-pipe temperatures during starts. On one recovery from blow-out the kerosene in the tail pipe ignited with explosive force and pushed the inner cone against the turbine wheel. Examination of the engine disclosed that the turbine was scored and the inner-cone retainer ring was torn off and wrapped around the inner-cone supports (fig. 31).

Fires occurred in the tail pipe and the rear section of the fuselage during high-altitude starts. After an unsuccessful attempt to start, fuel leaked through the joint between the exhaust cone and the tail pipe and settled in the bottom of the nacelle and in the bottom of the tail-pipe insulation. When the engine started, the fuel in the insulation and the nacelle also ignited. The resulting fire blistered the paint on the fuselage, burned the tail-pipe insulation, and warped the tail pipe (fig. 32).

In order to prevent tail-pipe fires after unsuccessful starts at altitude, a redesigned joint was installed and drain holes were drilled in the aluminum sheet of the tail-pipe insulation and in the bottom of the nacelle below the tail pipe.

SUMMARY OF RESULTS

The following results were obtained from an investigation of the operational characteristics of the I-40 jet-propulsion engine in the Cleveland altitude wind tunnel:

1. With all the fuel controls investigated, maximum engine speed and the lower blow-out limit could both be reached. The minimum engine idling speed increased with impact pressure, or air-speed, and pressure altitude. The lowest minimum stable engine speeds were obtained with the standard configuration using 40-gallon fuel nozzles and individual metering plugs. Slightly lower minimum idling speeds were obtained with gasoline than with kerosene at altitudes of 30,000 and 40,000 feet. The maximum difference in minimum speed obtained with several fuel regulators was 1000 rpm.

2. Satisfactory starts were made at pressure altitudes as high as 20,000 feet with all of the fuel-system combinations except one. Starting characteristics were sometimes improved by the use of an accumulator or electrically driven pump. The auxiliary fuel system usually had to be used to ignite the engine at an altitude of 30,000 feet, and, although successful ignition occurred, acceleration was slow and usually characterized by excessive tail-pipe temperature. The time for ignition was approximately the same with gasoline or kerosene. Starting acceleration to 6000 rpm was noticeably shorter with gasoline than with kerosene. During the windmilling investigations of the engine equipped with the standard fuel system, ignition was impossible at ram pressure ratios of 1.1 to 1.7 at altitudes of 10,000, 20,000, and 30,000 feet.

3. The engine equipped with the production barometric and Monarch 40-gallon nozzles accelerated in 12 seconds from 6000 to

784

11,000 rpm at 20,000 feet and an average tail-pipe temperature of 1100° F. At the same altitudes and average tail-pipe temperature, all the engine configurations had approximately the same rate of acceleration. The Woodward governor produced the safest accelerations inasmuch as it could be adjusted to automatically prevent acceleration blow-out.

4. At constant throttle position the engine speed was held constant by the Woodward governor and Edwards regulator during simulated dives and climbs. The barometric, however, compensated for altitude insufficiently to keep the engine speed constant.

5. The bearing-cooling system was satisfactory at all altitudes and airspeeds.

6. The maximum vibration of 0.0013 inch encountered was small and well within the manufacturer's limit of 0.003 inch.

7. The three engines used during this investigation operated without serious failure, but damage did occur to the exhaust cone, the tail pipe, and the airplane fuselage during high-altitude starts.

Flight Propulsion Research Laboratory,
National Advisory Committee for Aeronautics,
Cleveland, Ohio.

APPENDIX - FUEL REGULATORS

This section presents a description of the standard, Edwards, and Woodward fuel regulators.

Standard

Governor. - The governor is a bypass valve controlled by fly-ball weights that act to prevent rotor overspeed in excess of 11,500 rpm. As this speed is reached, centrifugal force causes a weight-and-spring assembly to fly outward and contract vertically. In contracting the spring contacts a spring-loaded spindle, by which the governor valve is opened and fuel is bypassed from the high-pressure line between the fuel pump and the nozzles. The governor is mounted on the accessory-gear casing and is geared to the turbine shaft.

Barometric. - The barometric (fig. 33) is a pressure-regulating valve that automatically provides the throttle with sufficient fuel to maintain constant speed as the altitude changes. The bulk of the bypassed fuel enters through inlet A, passes into the control valve B through the lower ports, and proceeds upward through the valve and out restricting ports to the fuel outlet C. A small amount of the high-pressure fuel goes past the control valve and through a filter D to the pilot valve E, where it is available to actuate the control piston F.

When the airplane ascends, the decreasing ambient pressure in the lower bellows G (which is opposed by an evacuated bellows H) lowers the force exerted on the under side of the lower-bellows top plate I and thus reduces the pull opposing the tension spring J; the tension spring therefore pulls the connecting stem K downward and lifts the pilot valve E through the bellows level L. The fuel that has been trapped under pressure above the control piston F is allowed to escape into the casing M. The casing is drained to the fuel outlet C. The control-valve spring N forces the control piston F upward and the piston level L is turned about its pivot O to restore the pilot valve E to its original position. The upward movement of the control piston F also changes the spring loading on the control valve. As a result, the high pressure in the control valve acts against an area P, forces the valve up, and enlarges the area restricting the bypass flow. The pressure of the main fuel-pump-discharge line is reduced and less fuel flows to the throttle. The reduced fuel requirements of the gas turbine are therefore met without readjustment of the throttle. When the airplane is descending, the barometric functions similarly to

increase fuel flow. By use of two bellows, pressure variations within the casing are balanced against equal areas and the pressure variations thus have no effect upon the bypass setting of the control valve.

Edwards

Fuel pump. - The Sundstrand pump (fig. 34) consists of a variable-displacement fuel pump 27 and a constant-displacement oil pump 28. The fuel pump contains numerous cylinders and the output flow is controlled by the angular position of the wobble plate, which adjusts the piston stroke. The wobble-plate position is determined by the adjustable-control oil pressure delivered by the fuel regulator 8. This pressure acts through a hydraulic relay 26 in the pump to determine the pressure in the positioning piston and thereby the wobble-plate position. A fixed ratio exists between the adjustable-control oil pressure and the fuel pressure at the nozzles; setting the adjustable-control oil pressure is therefore equivalent to setting the fuel pressure. The oil pump furnishes constant-pressure control oil to the hydraulic relay of the fuel pump and to the fuel regulator.

Fuel regulator. - The center of the control system is the fuel regulator 8 (fig. 34). This regulator is geared to the turbine shaft and is connected to the variable-displacement fuel pump 27 by means of hydraulic lines. A manual input is provided to set the regulator at any required power output. Rotation of the manual input operates control valve 23 through bell crank 15 and lever 25 and adjusts the variable-speed governor through lever 13. As bell crank 15 moves to the left, control valve 23 moves to the left in the cylinder and allows oil to flow from the constant-pressure-control oil line into the variable-pressure-control oil line, where it can react on the hydraulic relay 26 of the Sundstrand pump 27 and thus increase the fuel flow by increasing the pump stroke. This oil pressure also moves lever 25 through power piston 24. This action closes control valve 23. The trapped oil maintains the pump at a given stroke through the hydraulic relay.

If the turbine exceeds the speed set by the manual input, fly weights 10 in the overspeed governor cause a pilot valve 9 to open. Constant-pressure control oil can then reach power piston 11, which moves bell crank 14 against bell crank 15, closes control valve 23, and thus takes control from the manual input. Piston 11 also moves lever 12, closing pilot valve 9, and thus maintains the corrected position of bell crank 15. For any given setting of the overspeed governor, a maximum speed can be achieved by variation of the manual input.

Thermal units are sometimes used to prevent excessive temperatures in the tail pipe. The thermal unit 7 acts as an oil-pressure regulator by holding a definite pressure for each temperature throughout a range. Constant-control oil pressure is applied through a flow-metering device 1 to the thermal piston 3 and the thermal unit. If the manual input is set to require a higher temperature than is considered safe for operation of the turbine, the thermal unit allows the oil pressure in the thermal piston 3 to reduce. This piston moves lever 16 against bell crank 15 and takes control away from the manual input; the turbine then operates at the specified maximum temperature.

The maximum fuel pressure required for sea-level operation is several times that required at high altitude. In order to reduce the sensitivity of the control at high altitudes and still provide for maximum fuel pressure at sea level, spring 22, which acts on the fuel-pressure piston 24, must be recalibrated. This recalibration must be a function of the altitude. In order to achieve the variable gradient required for this recalibration, two levers 19 and 21 are used to couple the spring to the fuel-pressure piston. A roller 20 is placed to transmit force from one lever to the other. Variation in the position of this roller causes a variation in the effective spring gradient on the fuel-pressure piston. This roller 20 is connected by means of a yoke 18 to the altitude-compensator power piston 17, which positions the roller as a function of altitude. A pair of bellows is provided to determine the altitude. Bellows 4 is evacuated and bellows 6 is open to atmospheric or compressor-discharge pressure. Motion of this bellows combination causes the altitude-compensator control valve 5 to operate and vary the position of the altitude-compensator power piston 17. In order to maintain stable operation, the spring gradient should decrease rapidly and increase slowly. This action is accomplished by means of a flow-metering device 2 in the output line from the altitude-compensator control valve 5. A small axial slot is cut in the input shaft to the fuel regulator. Ports are so arranged that oil may flow into one end of the slot and out the other end at one particular point during each revolution of the shaft. During the remainder of the revolution, the ports are closed off and no oil is permitted to flow. The flow is thus limited as in an orifice, except that all openings are considerably larger than required in an equivalent orifice and the danger of clogging is thereby greatly reduced. In addition, when the speed of the rotating shaft is high enough, the inertia of the fluid trapped in the slot becomes more important than the viscous forces and, as a result, the drop across flow-metering device 2 is independent of fluid viscosity and is a function only of the flow rate and the density of the fluid.

Woodward Governor

The Woodward governor (fig. 35) is mounted on the accessory pad of the engine and is geared to the turbine shaft. The main governor has five parts:

The fuel pump V is of the gear type with a capacity of approximately 8500 pounds per hour.

The main governor consists of a sensitive flyball head O, whose movement is opposed by a spring H. The balls operate a pilot valve N sliding in a central bore in the pump drive gear. The pilot valve, when the engine is on the desired speed, covers pilot-valve ports R and prevents movement of the fuel-flow control-valve plunger S. The control-valve plunger is operated by a piston Q that is part of the valve. Pump-discharge pressure constantly acts on the top area of the piston to produce a force to close the valve, which is balanced by trapped fuel acting on a larger area on the bottom side of the piston. If the engine speed increases over the speed setting, the pilot valve N raises and vents the lower side of the piston to pump-inlet pressure and allows the pump-discharge pressure on top of the piston to move the control valve plunger in a decrease-fuel direction. If the engine speed decreases below the governor setting, the pilot valve N moves down to admit high-pressure fuel to the under side of the piston and move the control-valve plunger R upward to admit more fuel to the engine. Stability during fuel-flow corrections is obtained through an auxiliary spring G, which is actuated by the control-valve plunger through a dashpot piston M. The dashpot piston M slides in a cylinder in the top of the control-valve plunger and follows the movements of the control-valve plunger, inasmuch as fuel is trapped between the cylinder and the piston. This motion increases or decreases the load on the flyballs through a lever to which is connected the auxiliary spring G. This change in load on the flyballs produces a temporary higher speed setting while the governor is acting to decrease fuel flow and a temporary lower speed setting while the governor is acting to increase fuel flow. The dashpot piston is normally centered by spring B. The rate at which the dashpot returns to its normal onspeed-centered position is controlled by a needle valve F, which limits the rate at which the trapped fuel may leak in or out of the dashpot.

The differential relief valve U controls the pressure drop across the fuel-control valve T and also bypasses the part of the fuel being pumped that is not required by the engine. Top side of the relief valve U is exposed to pump-discharge pressure and an equal area on the bottom side is exposed to governor-discharge

pressure. Therefore, the pressure drop from the governor pump to governor discharge depends upon the spring used in the differential relief valve.

Speed adjustment is made by varying the preload on spring H. Speed adjustment and the manual-control valve X are operated by one linkage that requires only one throttle lever. Approximately the first 30° movement of the control shaft operates the manual valve X, and through approximately the next 60° any governor speed setting may be selected from idle to maximum. The engine speed may be reduced below the idle-speed limit set by the stop C only when the throttle is moved back into the manual range and fuel flow is throttled manually by valve X. The governor speed adjustment is loaded to high speed by spring P. When an increased speed adjustment is made, the control shaft moves a stop E, which allows gear I to revolve under the action of spring P through the gear and rack arrangement. The throttle may be moved to a higher speed setting as fast as desired. The acceleration dashpot K limits the rate at which the speed is increased by restricting the movement of the gear train. Leakage from the dashpot, which determines the rate of acceleration, is adjusted by the pin L. A variable orifice J accelerates the rate of speed adjustment in the high speed ranges.

A bypass valve W is provided to bypass the governor pump and control valve S when boost pressure is higher than governor-discharge pressure.

The overspeed governor A is built into the pump idler gear and is factory-set at some speed slightly higher than the main-governor top speed. It operates only for some abnormal condition where the speed might go higher than allowable. This governor reduces the pressure acting on area U of the differential relief valve, which allows the valve to open and reduce the pump-discharge pressure.

REFERENCES

1. Gendler, Stanley L., and Koffel, William K.: Investigation of the I-40 Jet-Propulsion Engine in the Cleveland Altitude Wind Tunnel. I - Performance and Windmilling Drag Characteristics. NACA RM No. E8G02, 1948.
2. Dietz, Robert O., Jr., and Geisenheyner, Robert M.: Investigation of the I-40 Jet-Propulsion Engine in the Cleveland Altitude Wind Tunnel. II - Analysis of Compressor Performance Characteristics. NACA RM No. E8G02a, 1948.

- 784
3. Krebs, Richard P., and Foshag, Frederick C.: Investigation of the I-40 Jet-Propulsion Engine in the Cleveland Altitude Wind Tunnel. III - Analysis of Turbine Performance and Effect of Tail-Pipe Design on Engine Performance. NACA RM No. E8G02b, 1948.
 4. Hensley, Reece V.: Investigation of the I-40 Jet-Propulsion Engine in the Cleveland Altitude Wind Tunnel. IV - Analysis of Combustion-Chamber Performance. NACA RM No. E8G02c, 1948.

TABLE I.- ENGINE

Con- fig- ura- tion	Types of test	Fuel system			
		Nozzles	Fuel regulator	Regulator setting	Auxiliary start- ing system
1	Starting Acceleration	Monarch 40-gallon 80° spray angle	Standard I-40 barometric		
2	Starting Acceleration	-----do.-----	-----do.-----		
3	Starting	-----do.-----	-----do.-----		
4	Starting	-----do.-----	-----do.-----		
5	Windmilling starting	-----do.-----	-----do.-----		
6	Starting Acceleration Minimum speed	-----do.-----	-----do.-----		Accumulator
7	Starting Acceleration Minimum speed	-----do.-----	-----do.-----		-----do.-----
8	Starting Acceleration Minimum speed Steady running	Monarch 30-gallon 60° spray angle	-----do.-----		-----do.-----
9	Starting Acceleration Minimum speed Steady running	Duplex; small ports, 9 gal/hr; both ports, 45 gal/hr	Syracuse con- trol system		I-16 electrically driven main fuel pump
10	Starting Acceleration Minimum speed Steady running	-----do.-----	Edwards	Engine on governor above 9000 rpm	
11	Starting Acceleration Minimum speed	-----do.-----	-----do.-----	Engine on governor above 6500 rpm	I-16 electrically driven main fuel pump
12	Starting Acceleration Minimum speed Steady running	Monarch 30-gallon 60° spray angle	Woodward governor	Pin 1 fully in	Accumulator
13	Starting Acceleration Minimum speed	Duplex; small ports, 9 gal/hr; both ports, 45 gal/hr	-----do.-----	Pin 1, 1/8 turn out	I-16 electrically driven main fuel pump
14	Starting Acceleration	-----do.-----	-----do.-----	Pin 1 fully in	-----do.-----
15	Acceleration Steady running	-----do.-----	-----do.-----	Pin 1, 3 turns out	-----do.-----
16	Acceleration Steady running	-----do.-----	-----do.-----	Pin 2 fully in	-----do.-----
17	Acceleration	-----do.-----	-----do.-----	-----do.-----	-----do.-----

¹See figure 12.



784

CONFIGURATIONS

Starter	Electrical system		Combustion chamber	Engine time (hr)	
	Ignition system	Spark plugs		Before run	After run
Standard	Standard G.E. 24-volt AF type C-1 coils	One each of type A ¹ in burners 2 and 9	C	8.58	14.82
—do.—	G.E. 400-cycle transformer	—do.—	—do.—	14.82	18.51
—do.—	G.E. "buzz box"	—do.—	—do.—	20.92	27.33
—do.—	G.E. D-4 dual magneto	—do.—	—do.—	27.33	27.55
—do.—	Standard G.E. 24-volt AF type C-1 coils	—do.—	—do.—	23.82	23.82
—do.—	60-cycle 12,000-volt transformer	One each of type B ¹ in burner 3 with hole downstream and in burner 10 with hole upstream	—do.—	0.26	12.96
—do.—	G.E. D-4 dual magneto	One each of type B ¹ in burner 2 with hole downstream and in burner 9 with hole upstream	—do.—	0.26	12.96
—do.—	60-cycle 12,000-volt transformer	One each of type A ¹ in burners 2 and 9	—do.—	8.48	12.86
Starter-generator	2 Delco-Remy AF type C-1 coils	One each of type D ¹ in burners 2 and 9	E	34.13	44.06
Standard	60-cycle 12,000-volt transformer	One each of type A ¹ in burners 2 and 9	C	0.16	17.28
Starter-generator	2 Delco-Remy AF type C-1 coils	One each of type C ¹ in burners 2 and 9	E	1.63	18.02
Standard	60-cycle 12,000-volt transformer	One each of type A ¹ in burners 2 and 9	C	2.68	8.48
Starter-generator	—do.—	—do.—	E	20.53	25.93
—do.—	—do.—	One each of type D ¹ in burners 2 and 9	—do.—	25.93	30.05
—do.—	—do.—	—do.—	—do.—	30.05	31.70
—do.—	—do.—	—do.—	—do.—	31.70	32.91
—do.—	—do.—	—do.—	—do.—	32.91	34.13

TABLE II.- ENGINE STARTING INVESTIGATION



Con-figuration	Tunnel conditions			Engine conditions					Results					
	Altitude (ft)	Free-stream impact pressure (lb/sq ft)	Free-stream impact temperature (°F)	Wind-tunnel speed (rpm)	Initial throttle position (deg)	Auxiliary fuel system	Fuel manifold pressure with auxiliary fuel system (lb/sq in.)	Time between use of starter and of auxiliary fuel system (sec)	Time to ignite after starter on (sec)	Engine speed at ignition (rpm)	Fuel manifold pressure at ignition (lb/sq in.)	Maximum tail-pipe temperature (°F)	Time from start to 4000 rpm (sec)	Time from start to 6000 rpm (sec)
1	10,000	25	10	0	---	No	---	---	27	---	75	2000	---	---
	10,000	25	12	0	---	---	---	---	20	1000	30	---	---	---
	10,000	70	-20	---	---	---	---	---	---	1000	---	1750	---	---
	20,000	25	-9	250	---	---	---	---	30	1400	95	1800	---	---
	30,000	10	-58	---	---	---	---	---	---	1100	70	---	(a)	---
	58,000	2	-52	---	---	---	---	---	---	1200	---	---	(a)	---
2	10,000	16	-20	0	80	No	---	---	19	1000	60	1800	41	50
	10,000	25	-38	0	74	---	---	---	20	1100	80	2000	72	---
	25,000	25	-40	---	---	---	---	---	---	---	---	---	(a)	---
	30,000	25	---	---	---	---	---	---	---	1200	70	---	(a)	---
b3	10,000	13	-4	---	---	No	---	---	---	1500	70	1750	---	---
	15,000	25	-6	---	---	---	---	---	21	1000	93	1900	---	122
	20,000	23	-10	---	---	---	---	---	---	1100	70	---	(a)	---
	30,000	13	-42	---	---	---	---	---	---	---	70	---	(a)	---
b4	10,000	25	16	100	---	No	---	---	27	---	80	2000	---	120
	10,000	25	17	100	---	---	---	---	20	---	80	1800	---	68
	15,000	25	1	200	---	---	---	---	27	---	80	2000	---	125
	20,000	70	1	500	---	---	---	---	30	---	70	600	(a)	---
8	10,000	40	19	200	70	No	---	---	21	---	70	1500	65	70
	10,000	40	23	200	5	Yes	20	23.5	25	---	75	1500	64	74
	10,000	40	23	250	20	Yes	20	19	21	---	85	1680	63	70
	10,000	80	30	300	69	No	---	---	29	---	100	1100	72	80
	10,000	80	20	400	5	Yes	20	36	39	---	55	1400	76	83
	20,000	40	2	0	70	No	---	---	16	---	110	2000	128	134
	20,000	40	-5	0	20	Yes	20	25	27	---	80	2200	67	74
	20,000	80	5	500	70	No	---	---	14	---	130	1750	94	104
	20,000	80	-6	500	80	Yes	20	17.5	20	---	110	2000	60	---
	20,000	80	-5	500	70	No	---	---	18	---	100	1800	65	---
	30,000	40	-54	200	40	Yes	20	22	27	---	120	1700	(a)	---
	30,000	40	-41	---	40	Yes	0	24	28	---	110	2250	(a)	---
	30,000	40	-36	0	20	Yes	18	---	---	---	60	---	(a)	---
	30,000	40	-32	---	---	No	---	---	---	---	80	---	(a)	---

7	10,000	40	27	0	55	No	—	—	17	—	100	1800	67	86
	10,000	40	24	300	20	Yes	6	19	29	—	90	1780	60	72
	10,000	40	9	0	40	Yes	40	23	26	—	103	1750	74	—
	10,000	80	24	500	69	No	—	—	17	—	94	1200	72	87
	10,000	80	20	250	50	Yes	20	17.5	19	—	110	1850	38.5	46
	20,000	40	-7	300	50	Yes	20	15	18	—	90	2000	73	—
	20,000	80	4	500	68	No	—	—	15	—	110	1900	51	64
	20,000	80	-7	400	50	Yes	20	15.5	23	—	135	2200	62	—
	30,000	40	-38	200	40	Yes	40	32	(a)	—	140	—	—	—
6 and 7	20,000	40	-28	250	40	Yes	40	21.5	35	1800	120	2000	129	—
8	10,000	40	25	300	80	Yes	10	41	45.5	—	32	1550	80	—
	20,000	—	-11	0	80	Yes	10	23	26	—	27	1500	64	—
	10,000	—	18	0	75	No	—	—	54	—	12	1750	74	—
	25,000	—	-35	—	—	Yes	5	—	—	1100	—	—	(a)	—
9	10,000	40	26	0	0	No	—	—	25	—	—	1850	69	76
	20,000	—	-30	—	53	No	—	—	17.5 ^c	1300	60	2000	92 ^c	101.5 ^c
	10,000	—	25	—	—	No	—	—	14.7 ^c	—	50	1500	—	58 ^c
	20,000	—	-40	300	42	No	—	—	30	—	50	1500	72	83
	25,000	—	-44	200	42	No	—	—	28	—	49	1600	81	—
(d)	30,000	—	-44	—	—	Yes	—	—	(a)	—	—	—	—	—
10	10,000	40	19	0	—	No	—	—	30	1100	65	1900	81	—
	25,000	40	-23	450	—	—	—	—	26	1800	38	2000	—	—
	10,000	45	24	0	—	—	—	—	27	1800	20	—	66	—
	15,000	40	9	0	—	—	—	—	25	1200	30	1900	72	—
	20,000	40	-14	350	—	—	—	—	16 ^c	1200	30	—	115 ^c	—
11	10,000	40	15	300	54	Yes	42	—	29.5	—	—	1500	60	74.5
	20,000	—	-20	375	48	Yes	40	30	35	—	—	1900	91	108
	10,000	—	25	0	48	Yes	—	—	36	—	—	2000	71	88
	10,000	—	20	0	53	Yes	40	25	24	—	—	1750	—	—
	30,000	—	-27	600	—	No	—	—	—	1600	60	—	(a)	—
	10,000	—	0	0	48	Yes	—	—	27	—	—	1800	60	87.5
	20,000	—	-15	400	48	Yes	—	—	37	—	—	1500	67	76
	20,000	—	-20	375	—	Yes	40	—	26.5	—	—	1800	84	90
12	5,000	40	45	0	Full	No	—	—	12.5 ^c	—	10	—	35 ^d	—
	5,000	—	27	300	Full	No	—	—	22	—	11	1750	50	—
	5,000	—	37	300	Full	No	—	—	8 ^c	—	11	1750	28 ^c	—
	10,000	—	6	0	Full	No	—	—	30	—	18	1700	54	—
	20,000	—	-36	300	Full	No	—	—	38	—	18	2200	83	—
20,000	—	-39	300	Full	Yes	—	—	25	—	—	2000	123	—	
13	10,000	40	26	0	—	No	—	—	20	—	20	1750	52	—
	20,000	—	-30	—	35	Yes	38	—	41.5	—	—	1650	—	—
14	10,000	40	4	—	—	No	—	—	11.2 ^c	—	—	1550	—	55.8 ^c
	10,000	—	10	—	—	—	—	—	9 ^b	—	40	1550	62.5 ^c	87.2 ^c
	10,000	—	20	—	—	—	—	—	26	—	13	1700	76	—
	20,000	—	-16	300	—	—	—	—	27	—	50	1750	82	—
	30,000	—	-24	400	—	—	—	—	29	—	50	2100	94	119

^aStart unsuccessful; either no ignition or could not be accelerated after ignition.

^bData inconclusive; inner cross-ignition tubes fell into combustion chambers.

^cAfter stopcock open.

^dFuel, gasoline.



TABLE III - CONDITIONS FOR ATTEMPTED WINDMILLING

STARTS WITHOUT STARTER

(CONFIGURATION 5)

Simulated altitude (ft)	Static-air temperature (°F) (a)	Windmill-ing speed (rpm)	Ram pressure ratio	Airspeed (mph) (a)	Fuel-mani-fold pres-sure (lb/sq in.)
10,000	8	950	1.1	266	53
10,000	1	1425	1.2	388	110
20,000	-10	1350	1.2	379	67
20,000	-15	1800	1.3	465	77
20,000	-31	2400	1.5	570	99
30,000	-30	1300	1.2	368	62
30,000	-39	1650	1.3	450	75
30,000	-60	2375	1.5	560	92
30,000	-54	3000	1.7	676	125

^aStatic-air temperature and airspeed at the engine inlet were calculated from the indicated temperature in the ram duct, the total pressure at the compressor inlet, and the static pressure in the tunnel test section.



TABLE IV - COMPARISON OF ACCELERATION TIME FOR SEVERAL
 CONFIGURATIONS AND TWO FUELS

[Pressure altitude, 20,000 ft; average tail-pipe
 temperature, 1100^o F]

Configura- tion	Fuel system	Fuel	Time (sec) (a)
1-7	Barometric with Monarch 40-gal nozzles	Kerosene	12
8	Barometric with Monarch 30-gal nozzles	---do---	9
9	Syracuse barometric with duplex nozzles	Gasoline	12
9	Syracuse barometric with duplex nozzles	Kerosene	13
11	Edwards regulator with duplex nozzles	---do---	10
12	Woodward governor with Monarch 30-gal nozzles	---do---	10

^aTime to accelerate from 6000 to 11,000 rpm



TABLE V - ENGINE DECELERATIONS

Config-uration	Fuel system	Altitude (ft)	Impact pressure (lb/sq ft)	Engine speed (rpm)		Time to decel-erate (sec)	Time to retard throttle to idling position (sec)
				Initial	Final		
8	Standard baro-metric, Monarch 30-gal nozzles	10,000	40	11,500	6000	16	-----
8	---do---	20,000		11,500	6000	11	2
12	Woodward gover-nor, Monarch 30-gal nozzles	10,000		11,000	3500	17	3
12	---do---	20,000		11,500	4800	43	3
12	---do---	20,000		11,500	9000	42	3



TABLE VI - ENGINE VIBRATION

Altitude (ft)	Ram pres- sure ratio	Engine speed (rpm)	Ampli- tude of vertical vibra- tion, front support (in.)	Ampli- tude of vertical vibra- tion, trunnion support (in.)	Ampli- tude of hori- zontal vibra- tion, trunnion support (in.)	Ampli- tude of axial vibra- tion, trunnion support (in.)
10,000	1.1	3,003	0.0002	0.0002	0.0002	0.0002
		7,007	.0001	.0002	.0001	.0001
		10,000	.0004	.0007	.0002	.0004
		11,511	.0006	.0011	.0004	.0005
20,000	1.4	4,000	0.0001	0.0001	0.0001	0.0001
		7,007	.0001	.0002	.0001	.0001
		10,009	.0003	.0005	.0002	.0005
		11,511	.0007	.0013	.0004	.0006
30,000	1.8	6,006	0.0001	0.0001	0.0001	0.0001
		9,008	.0002	.0004	.0001	.0002
		10,510	.0004	.0008	.0003	.0005
		11,511	.0007	.0013	.0004	.0003
40,000	1.4	7,007	0.0001	0.0001	0.0001	0.0001
		10,009	.0002	.0004	.0001	.0003
		11,511	.0004	.0007	.0002	.0004



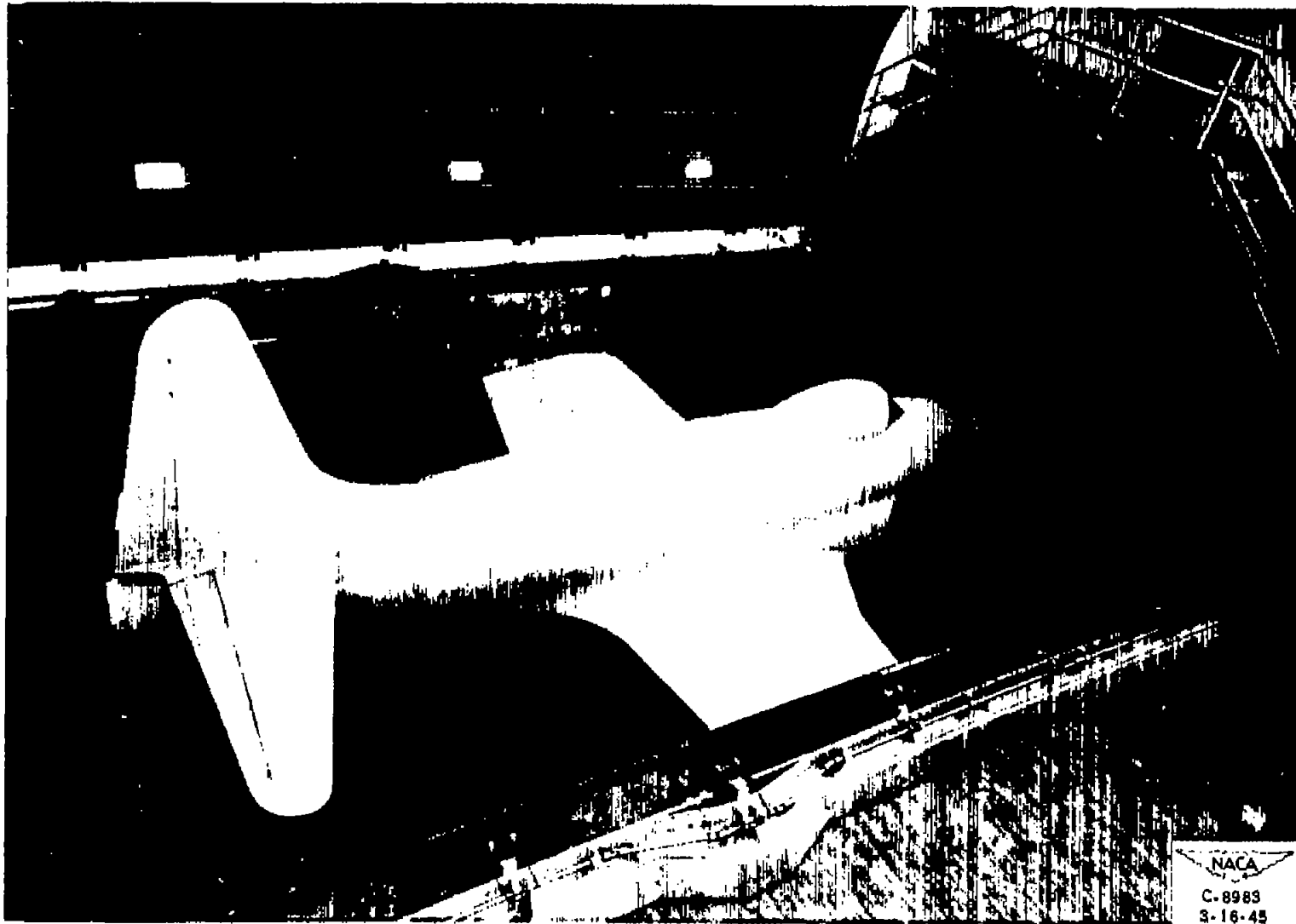

Figure 1. - Airplane fuselage installed in Cleveland altitude wind tunnel.

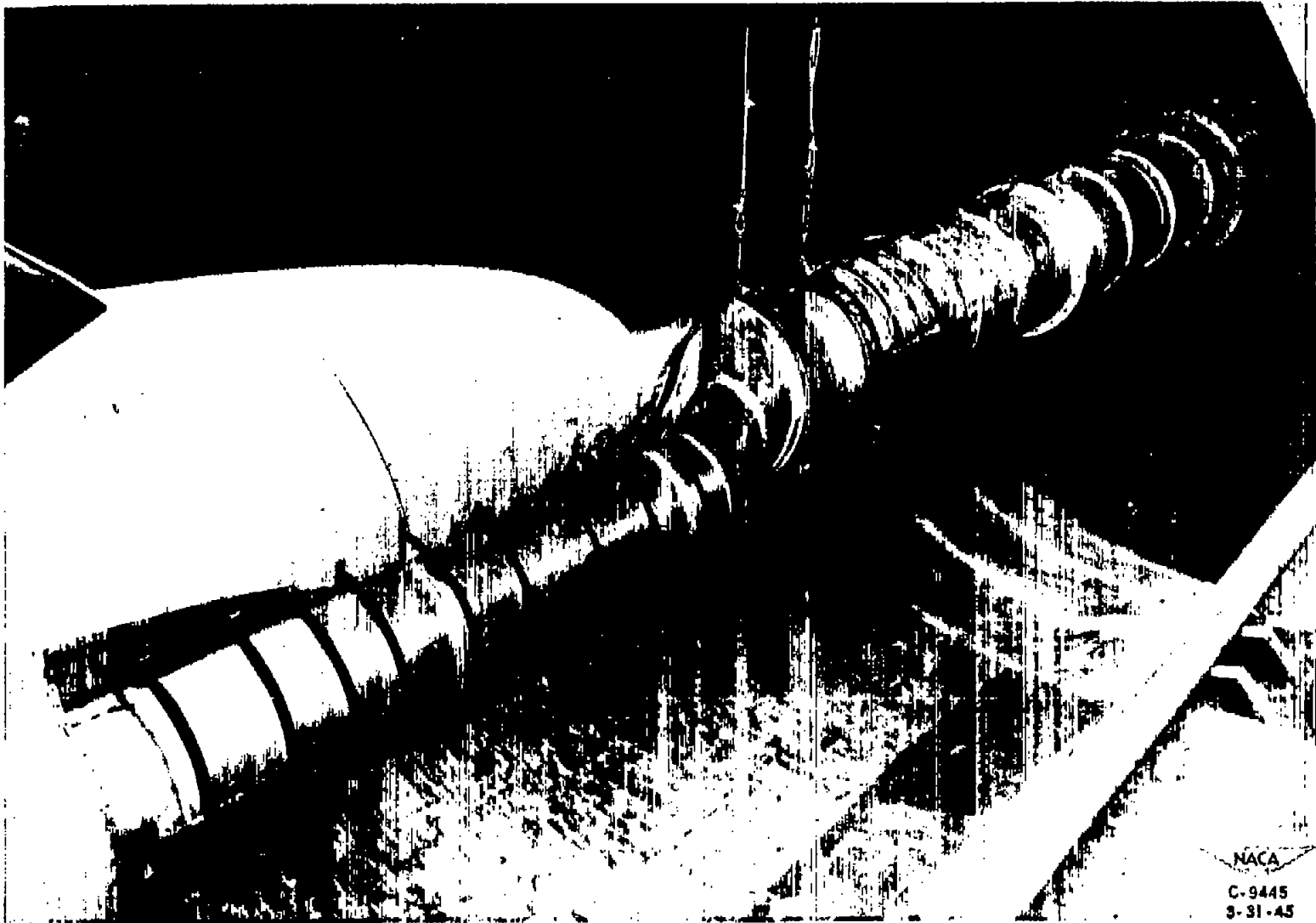

Figure 2. - Y ram pipe attached to nose of airplane fuselage.

- A Tail-pipe-nozzle-outlet static pressure
- B Calibration ring, total pressure and temperature
- C Tail-pipe temperature
- D Tail-pipe-nozzle-outlet total and static pressure and temperature survey
- E Engine cooling-air outlet total pressure

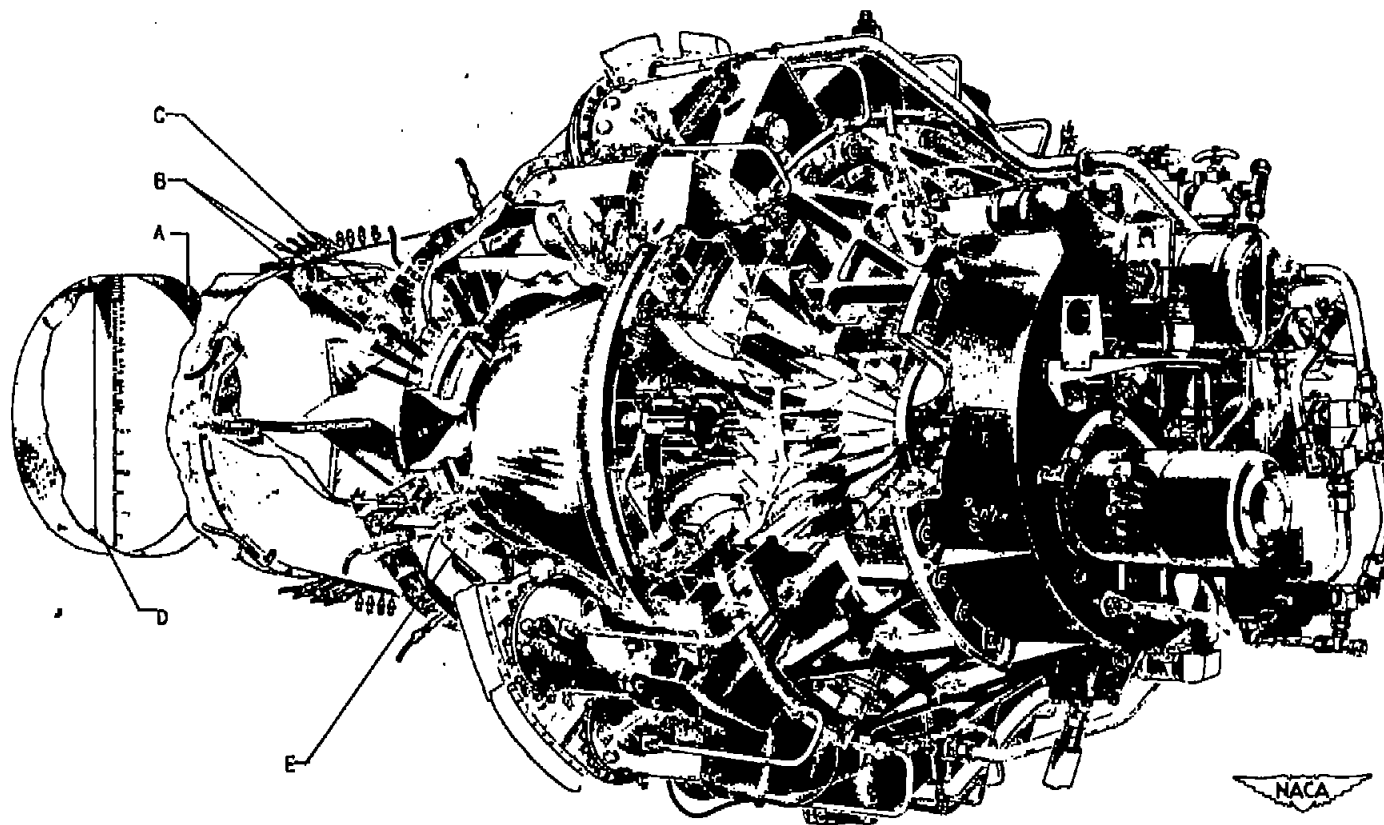

Figure 3. - Drawing of L-40 jet-propulsion engine showing location of instrumentation.

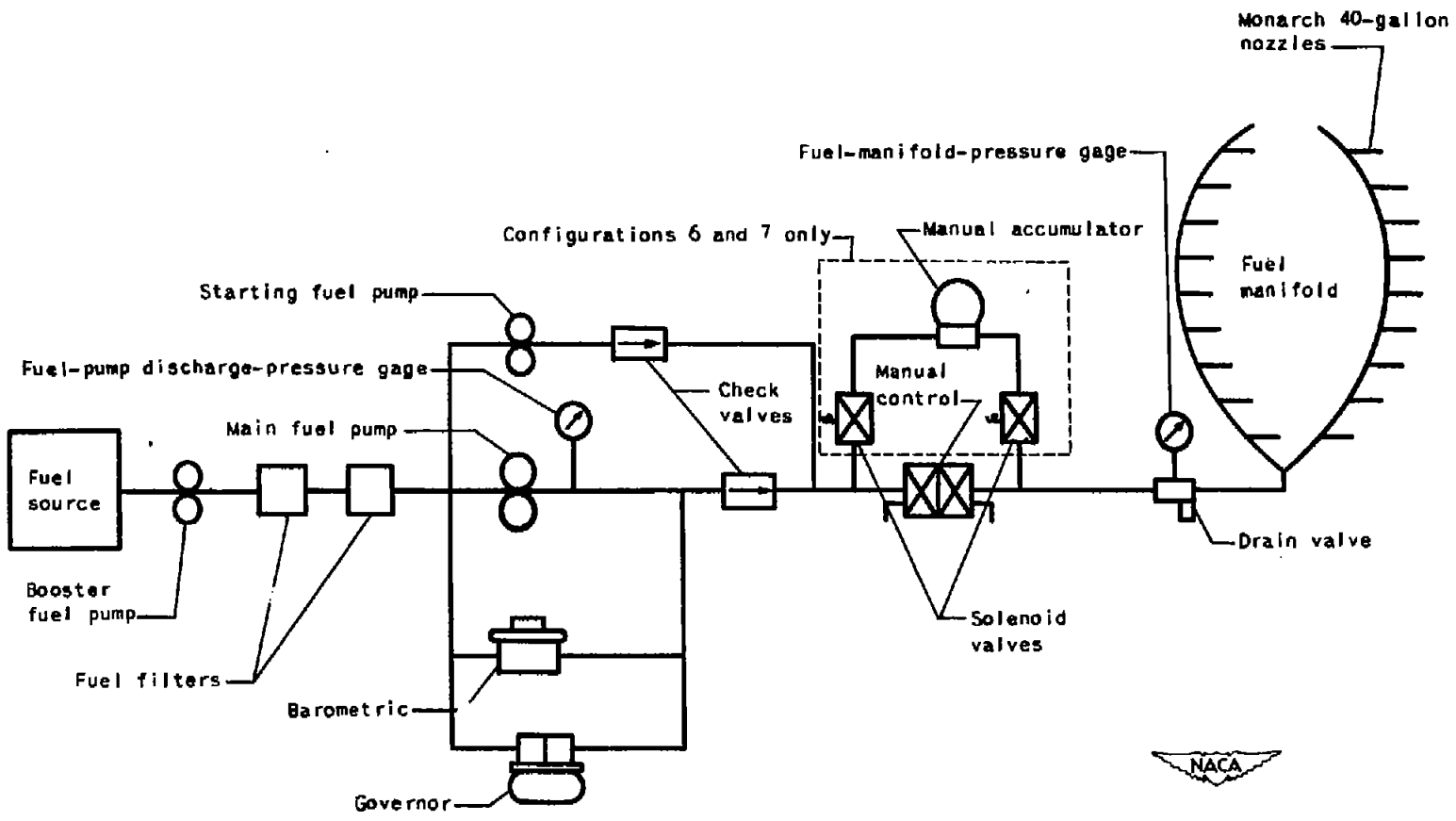

Figure 4. - Schematic diagram of standard fuel system of I-40 jet-propulsion engine with barometric and 40-gallon nozzles (configurations 1 to 7).

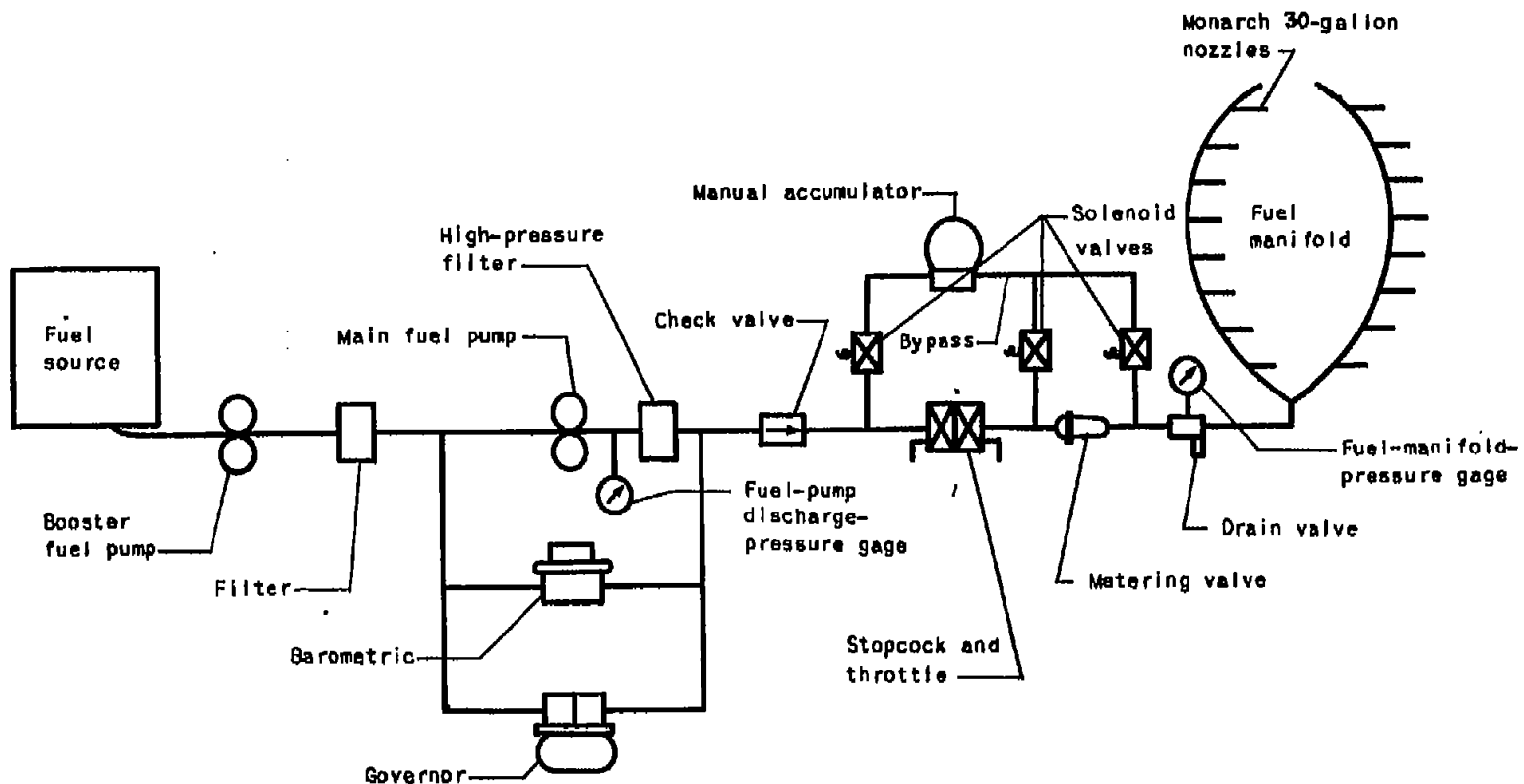

Figure 5. - Schematic diagram of fuel system of 1-40 jet-propulsion engine with standard barometric and 30-gallon nozzles (configuration B)—starting pump replaced by accumulator and metering valve.

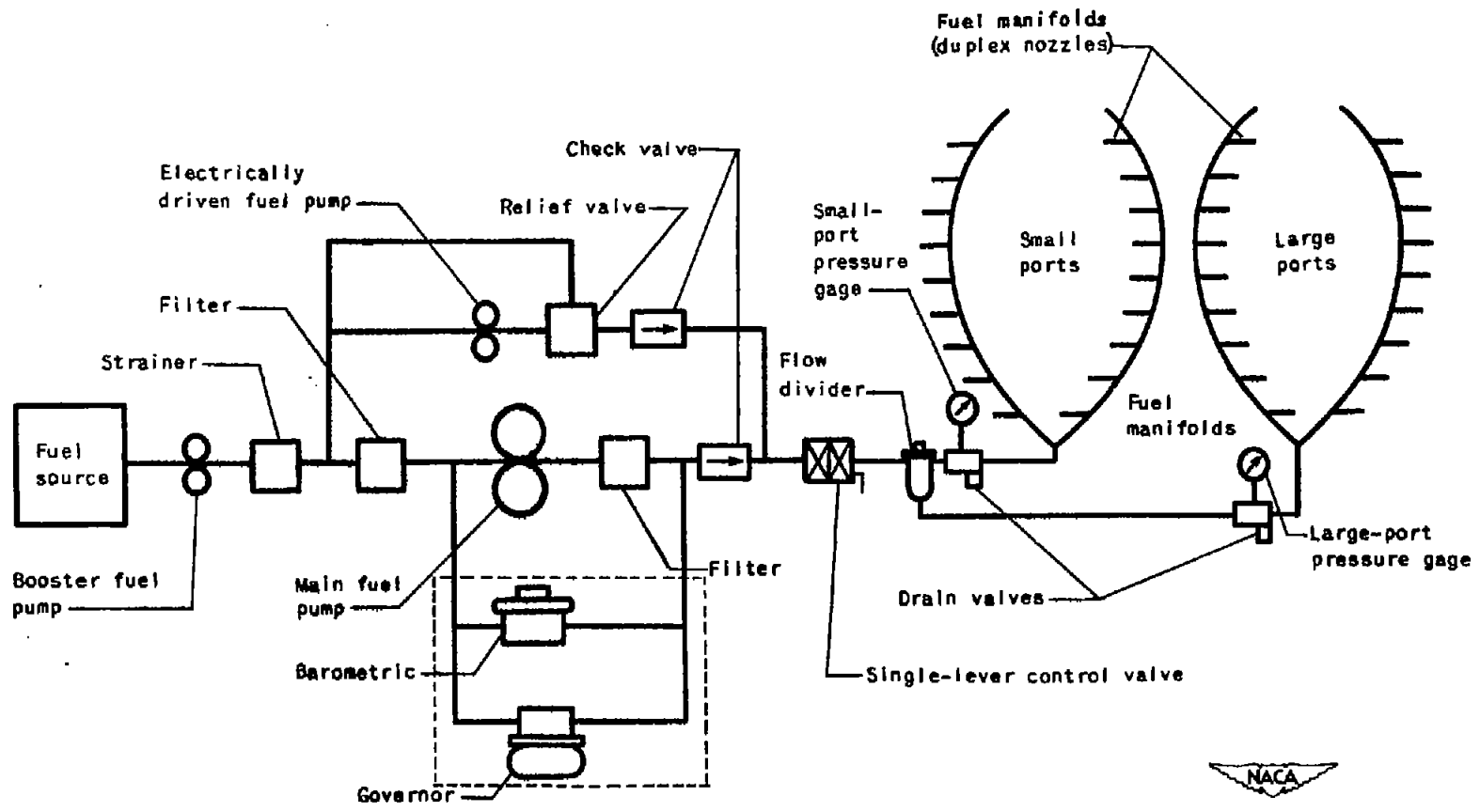

Figure 6. - Schematic diagram of fuel system of I-40 jet-propulsion engine with Syracuse control system and duplex nozzles (configuration 9).

3007852

784

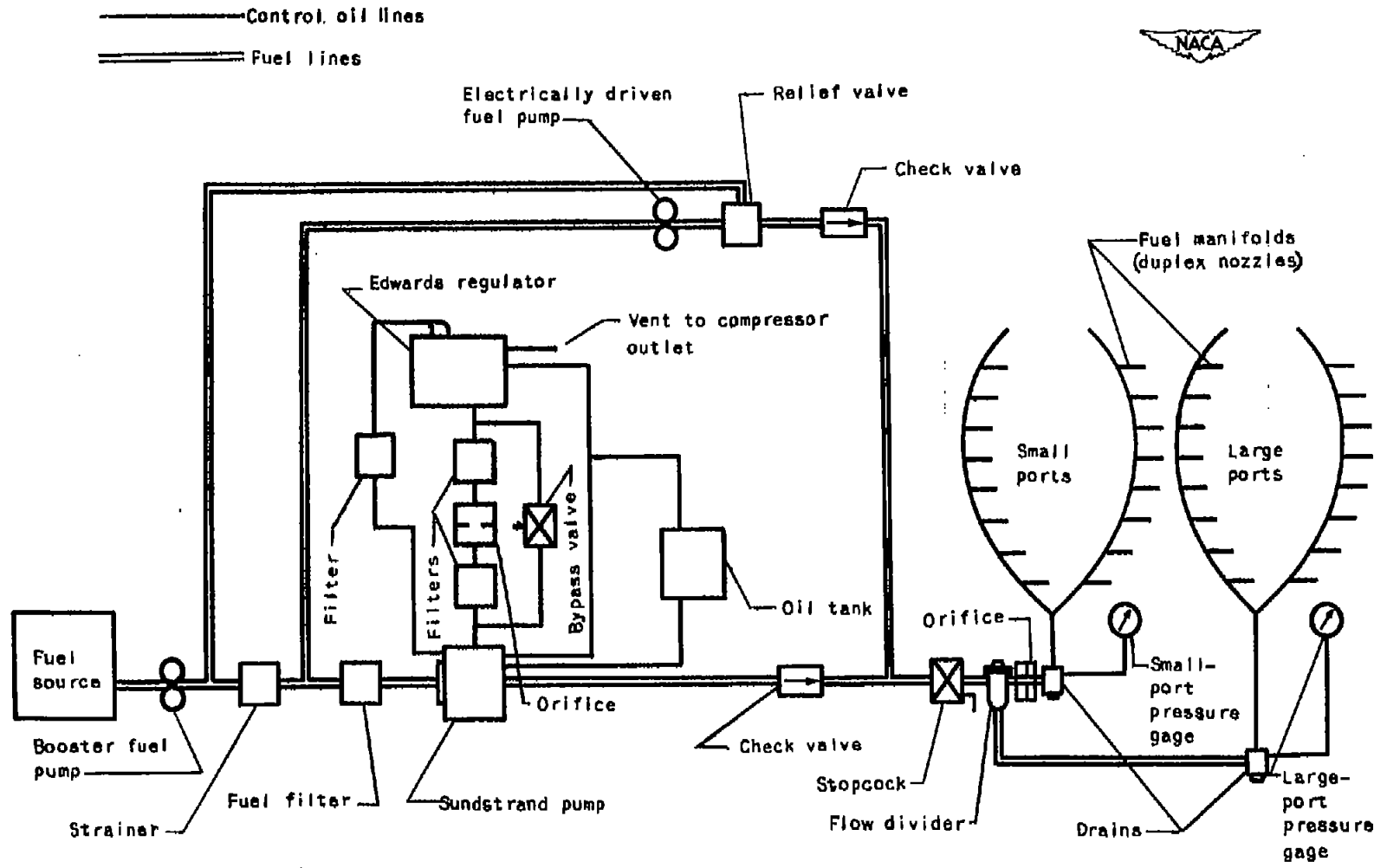

Figure 7. - Schematic diagram of fuel system of I-40 jet-propulsion engine with Edwards regulator and duplex nozzles (configurations 10 and 11, except that 10 has no orifices in small ports or variable-control oil lines nor electrically driven fuel pump).

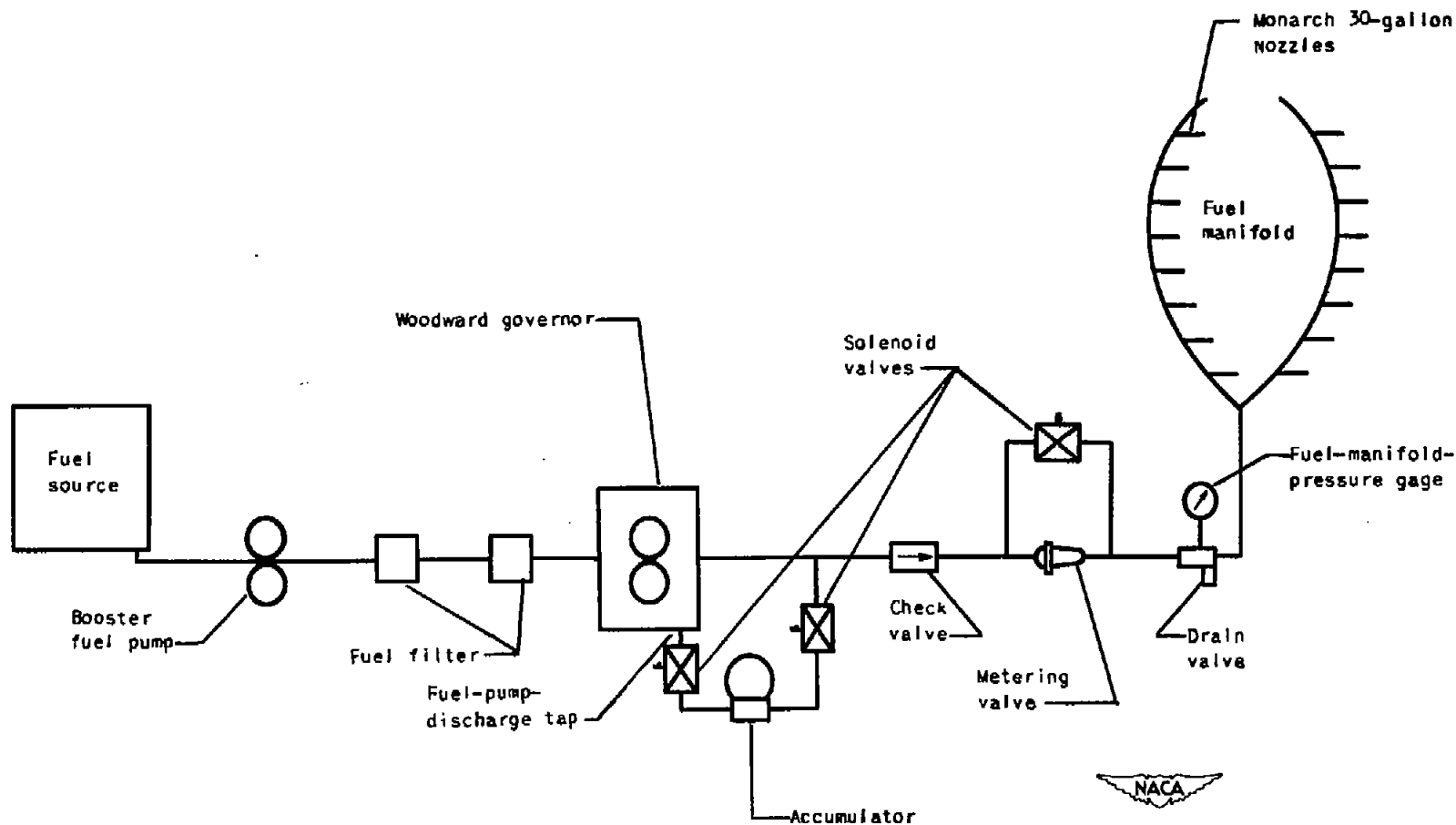

Figure 8.- Schematic diagram of fuel system of 1-40 jet-propulsion engine with Woodward governor and 30-gallon nozzles (configuration 12). Woodward governor incorporates main fuel pump, main governor, overspeed governor, relief valve, and manual-control valve.

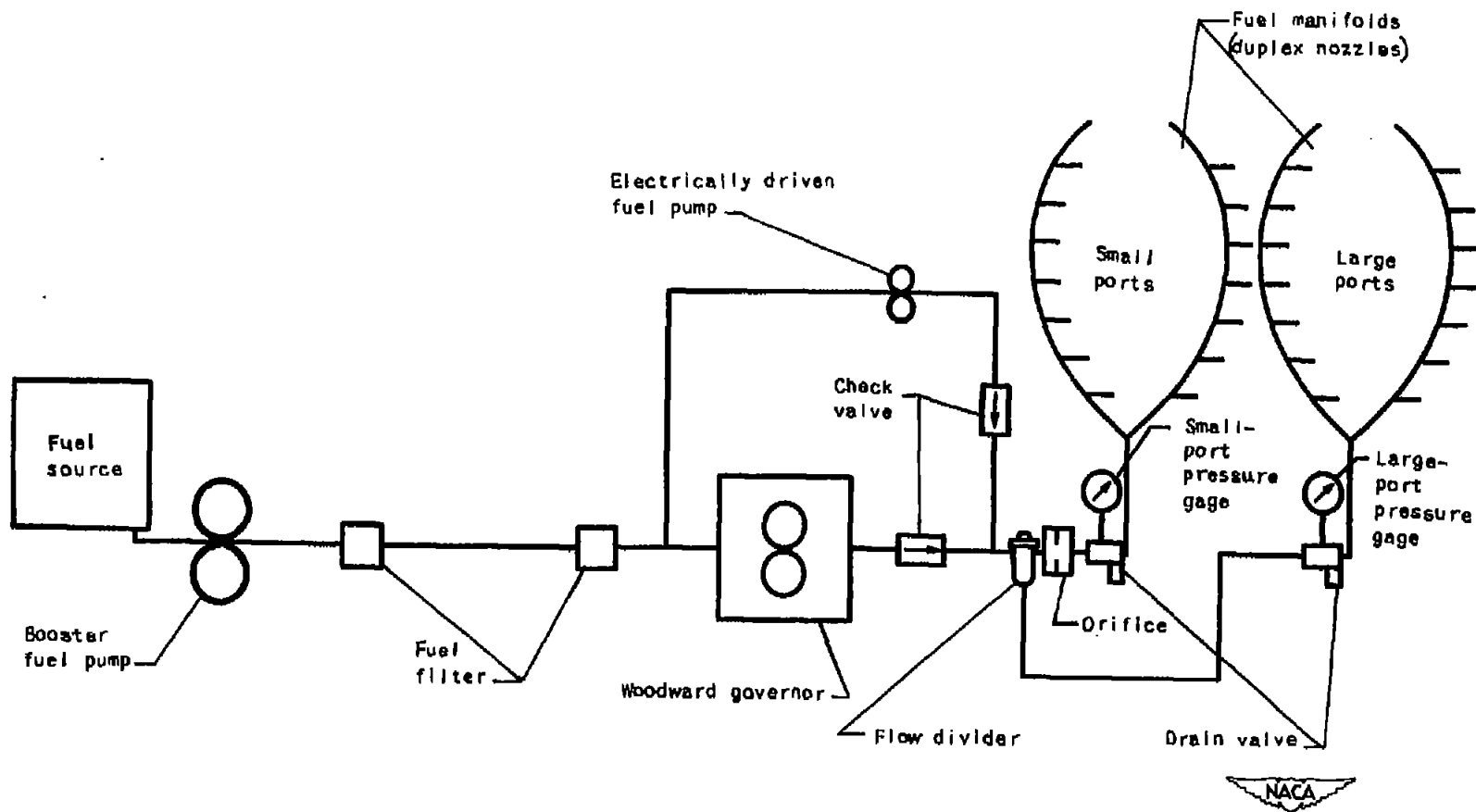
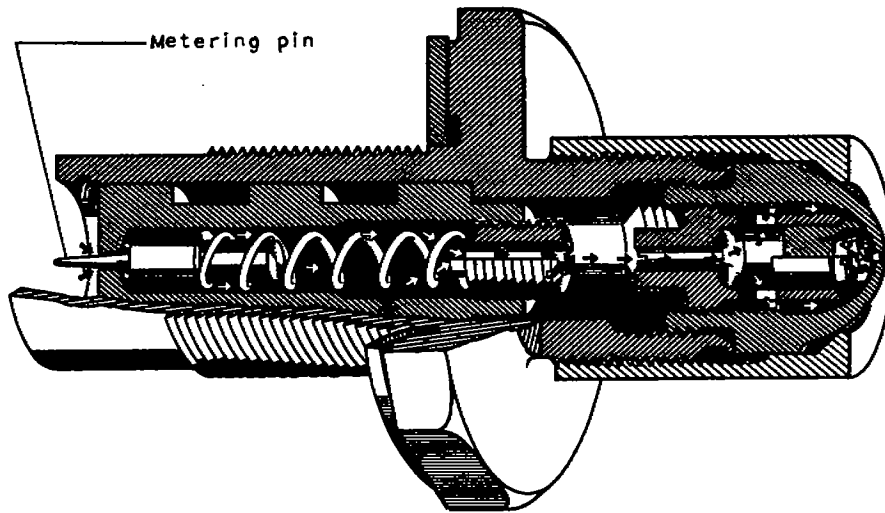
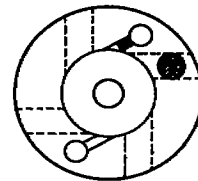

Figure 9. - Schematic diagram of fuel system of I-40 jet-propulsion engine with Woodward governor and duplex nozzles (configurations 13 to 17). Woodward governor incorporates main fuel pump, main governor, overspeed governor, relief valve, and manual-control valve.



(a) Monarch nozzle.



Cross section A-A

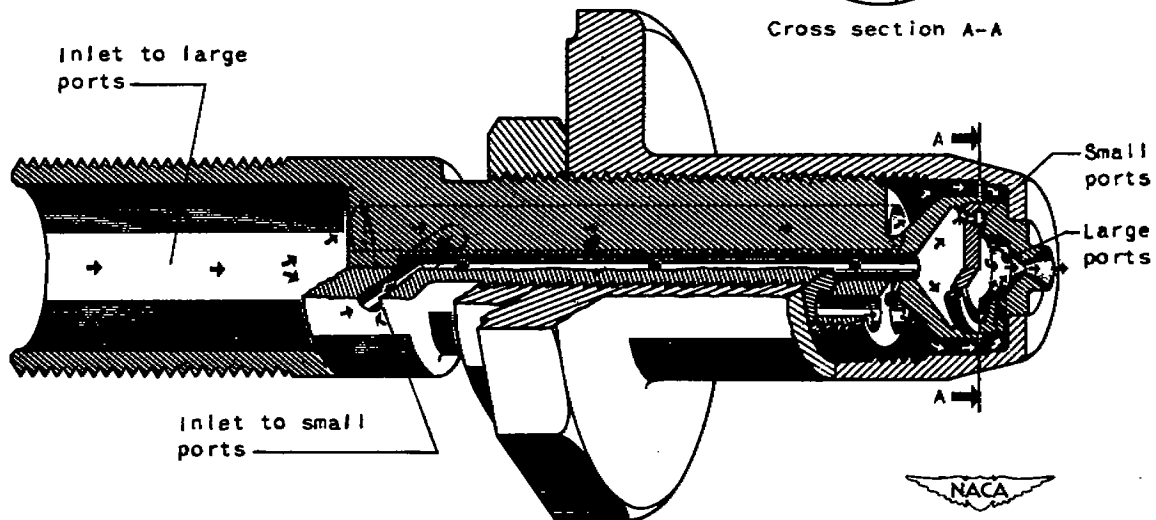

(b) Duplex nozzle.

Figure 10.- Types of fuel nozzle used in wind-tunnel investigation of I-40 jet-propulsion engine.



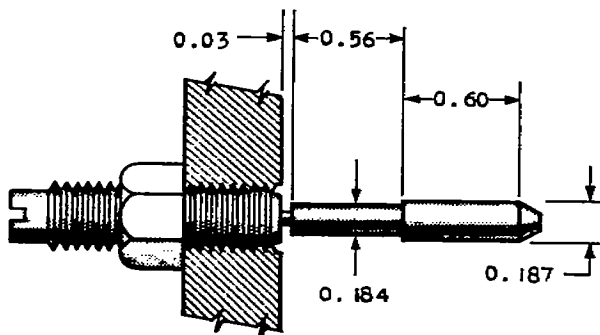
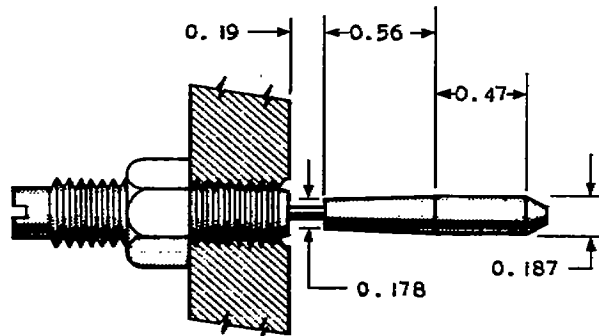
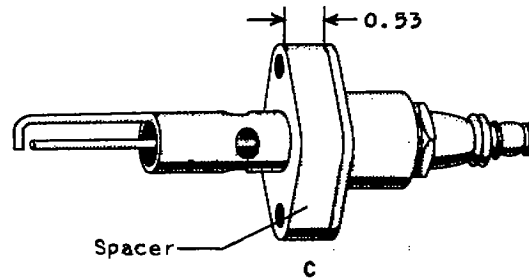
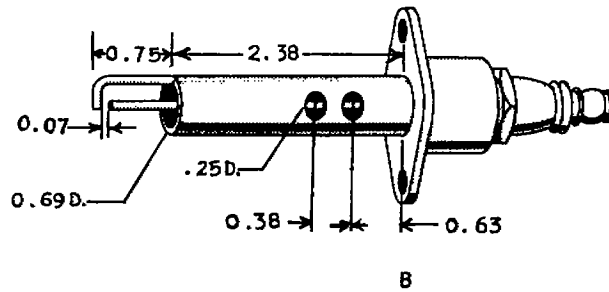
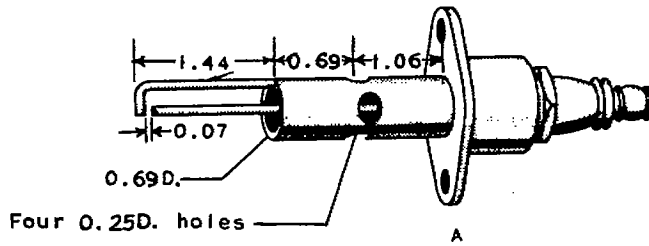

Figure 11. - Pins used in acceleration dashpot of Woodward governor.
(All dimensions in in.)

784

300+794



Same as A except for spacer

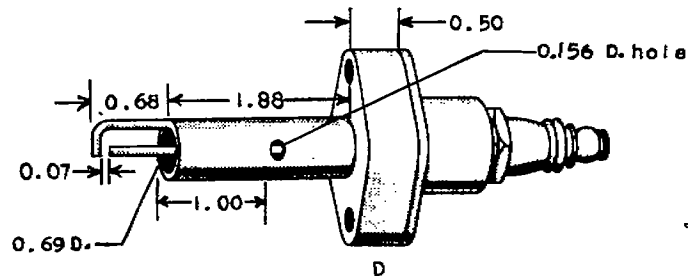
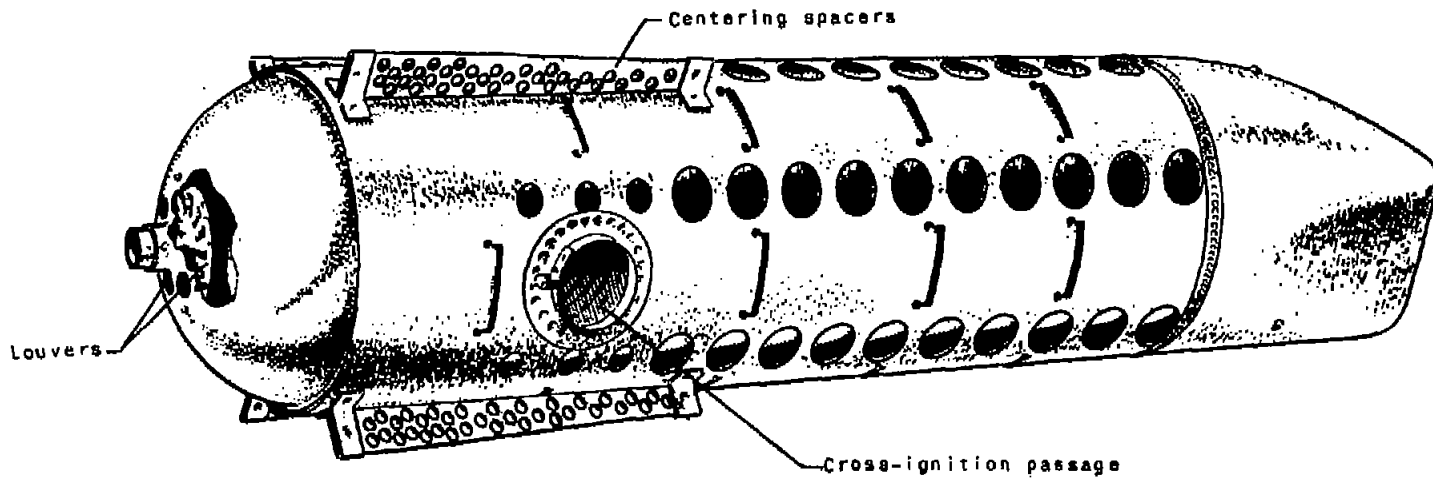

Figure 12. - Modifications of Champion D8 spark plug used in wind-tunnel investigation of I-40 jet-propulsion engine. (All dimensions in in.)

784

500+785



Type C liner and dome

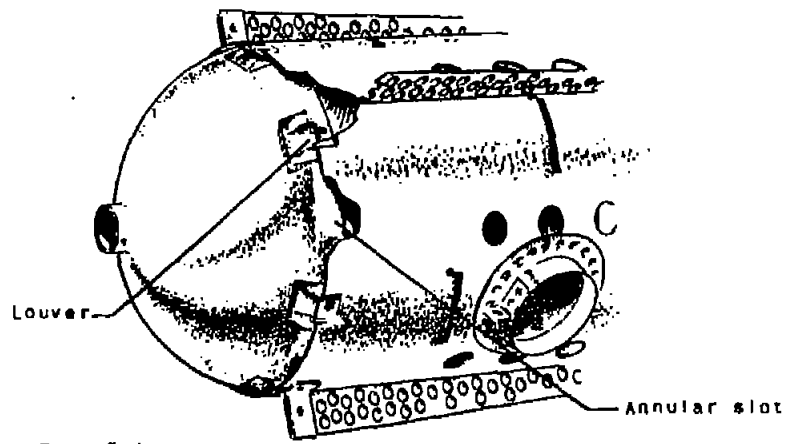

Type E dome

Figure 13. - Combustion-chamber liners used in I-40 jet-propulsion engine.

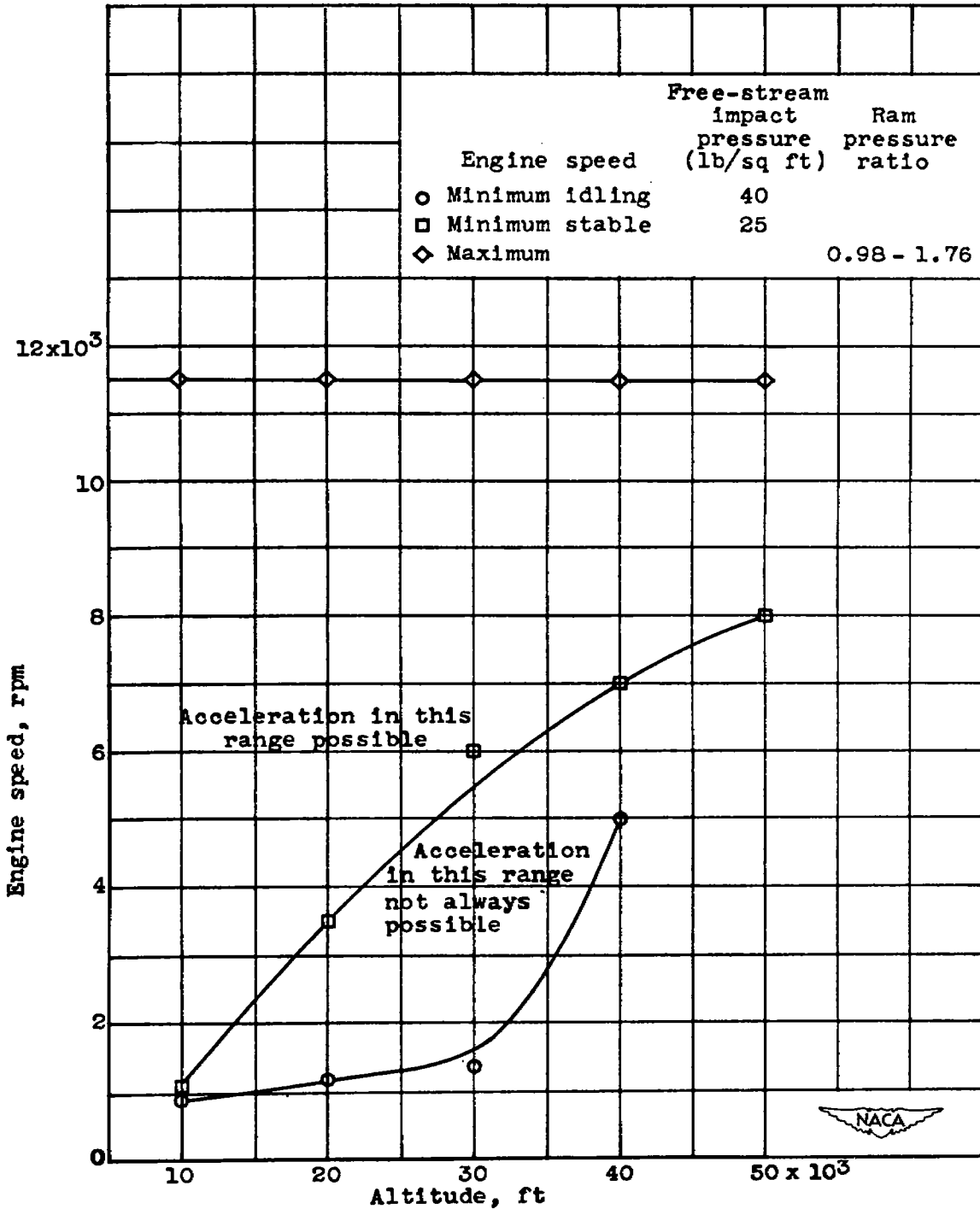

784

Figure 14.- Effect of altitude on operating range of I-40 jet-propulsion engine equipped with standard fuel system (configurations 1 to 7).

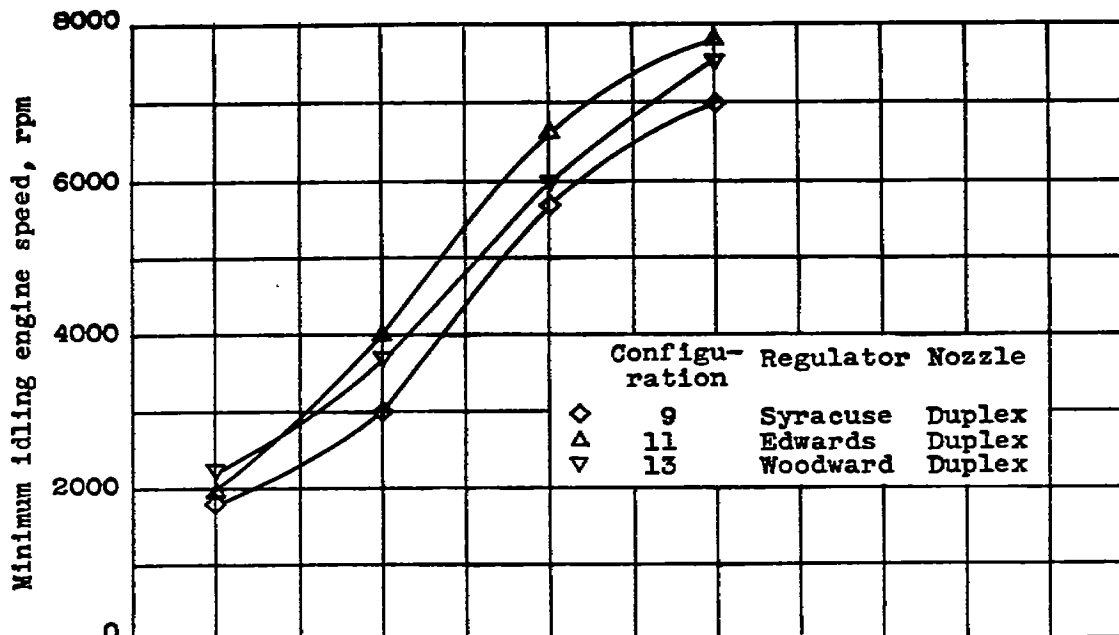

(a) Minimum idling speed.

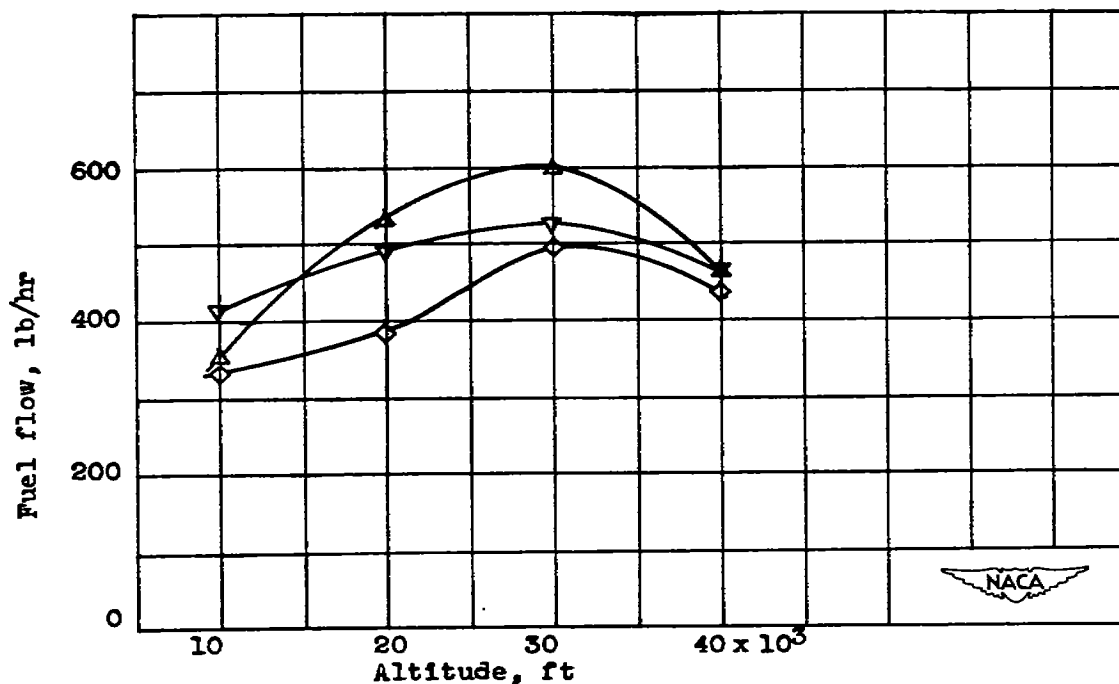

(b) Fuel flow required at minimum idling speed.

Figure 15.- Effect of altitude and fuel regulator on minimum idling speed and fuel flow required at minimum idling speed of I-40 jet-propulsion engine. Free-stream impact pressure, 40 pounds per square foot.



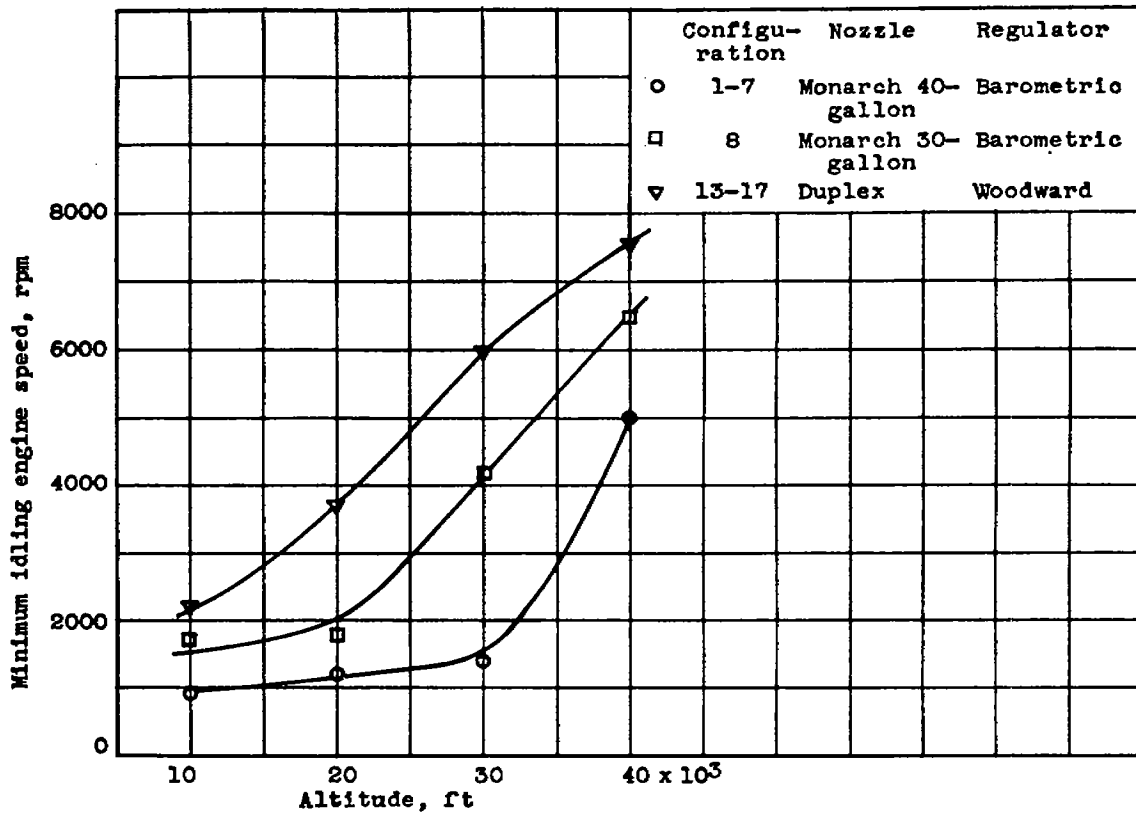

Figure 16.- Effect of altitude and fuel nozzle on minimum idling speed of I-40 jet-propulsion engine. Free-stream impact pressure, 40 pounds per square foot.

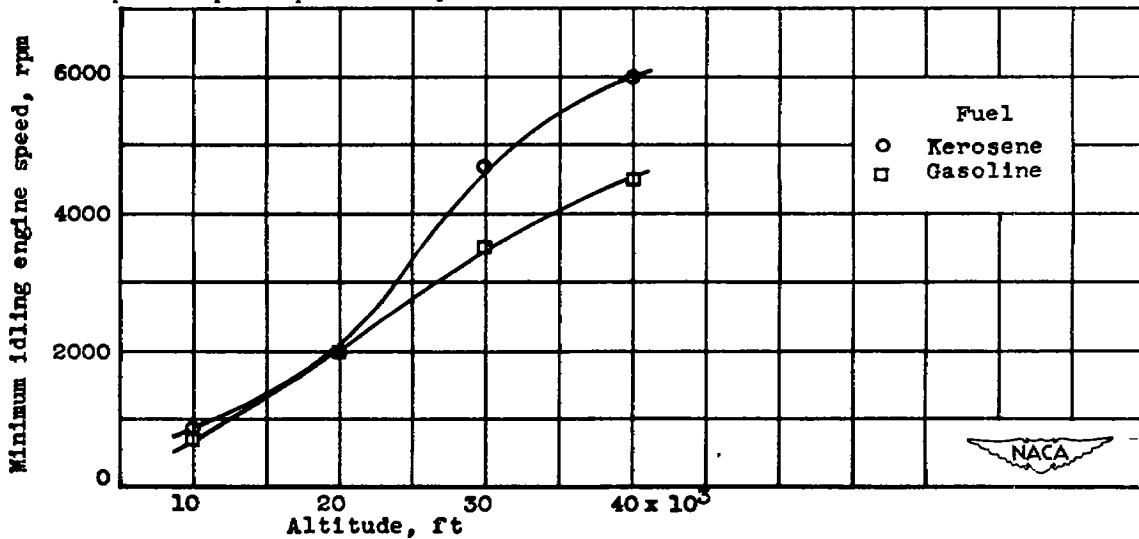

Figure 17.- Effect of altitude and fuel on minimum idling speed of I-40 jet-propulsion engine equipped with Syracuse barometric fuel control (configuration 9). Free-stream impact pressure, 40 pounds per square foot.

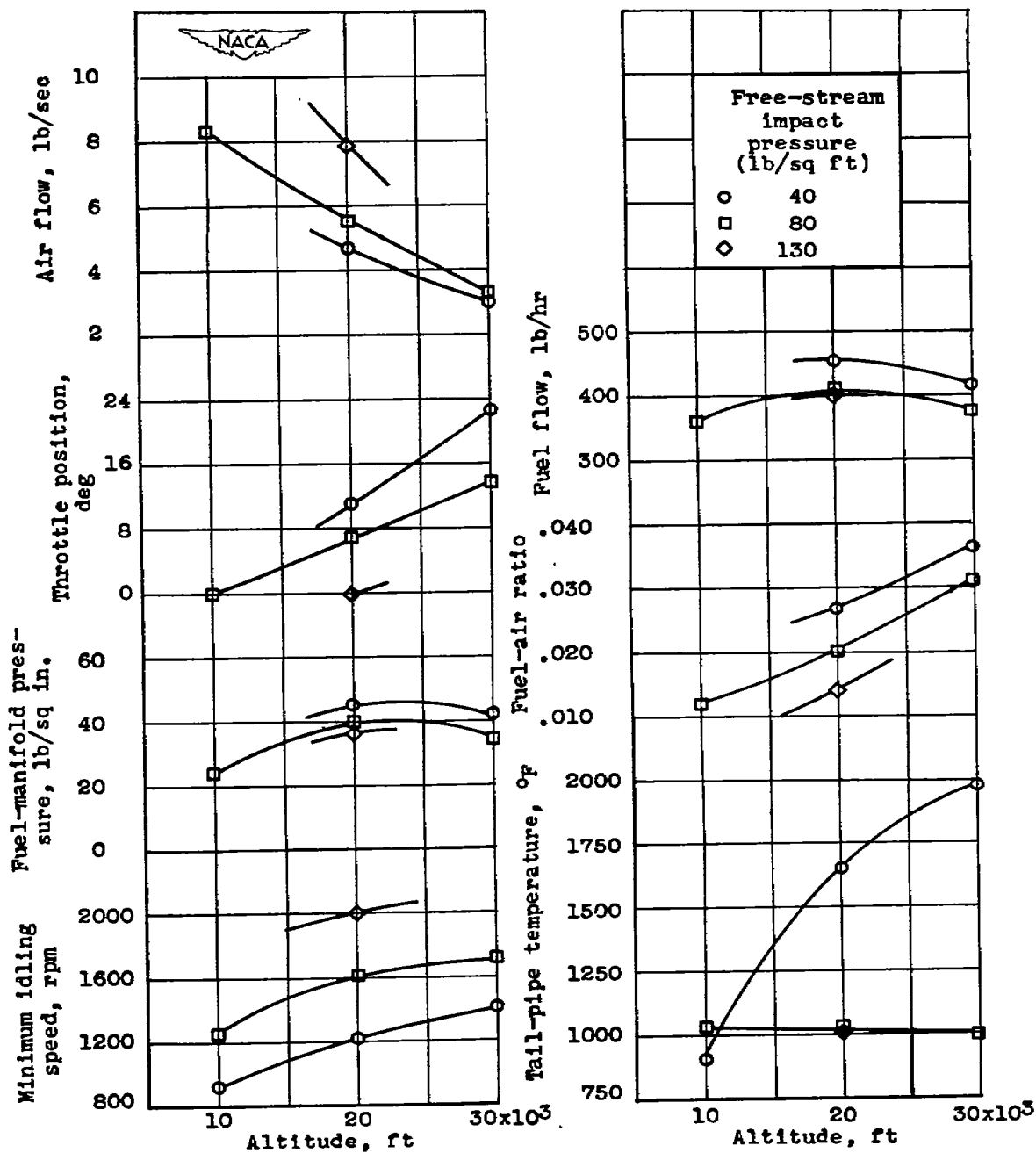

Figure 18.- Effect of altitude and impact pressure on operational parameters at minimum idling speed of I-40 jet-propulsion engine equipped with standard fuel system (configurations 1 to 7).

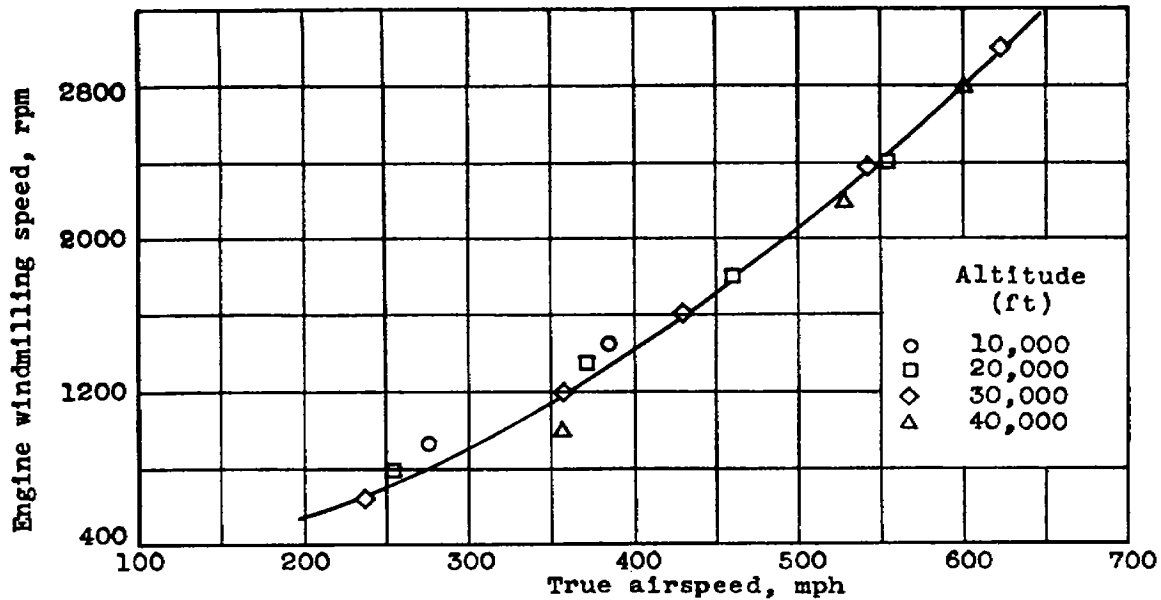

Figure 19.- Effect of airspeed and altitude on windmilling engine speed of I-40 jet-propulsion engine. Airspeed based on 100-percent free-stream total-pressure recovery.

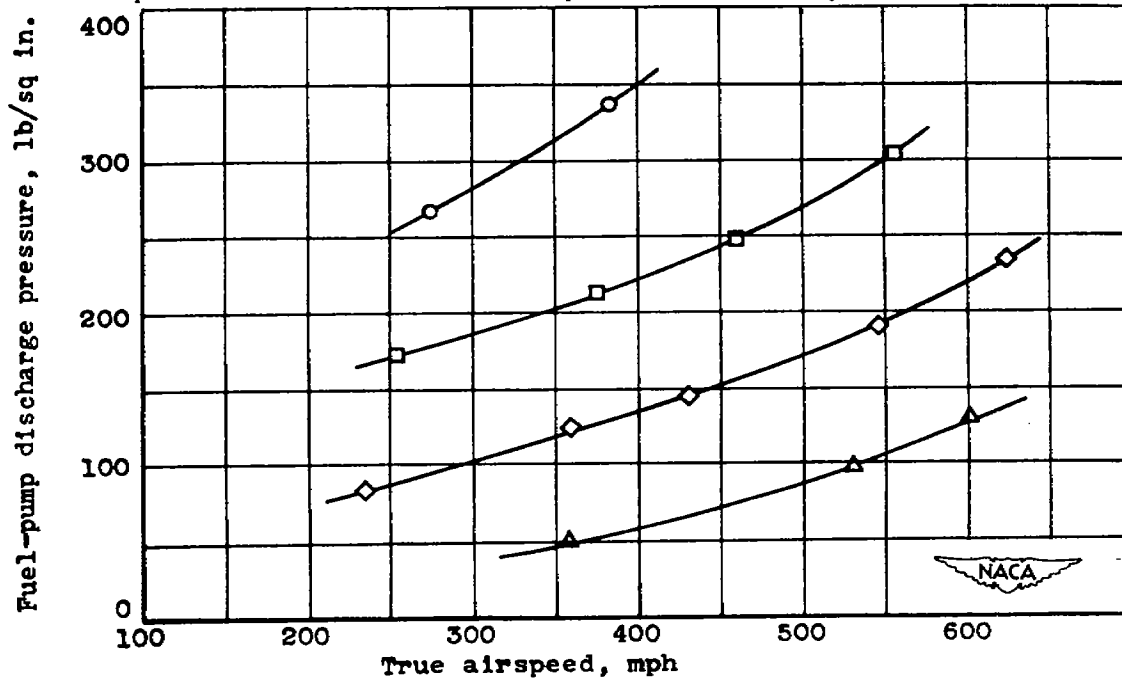

Figure 20.- Effect of airspeed and altitude on fuel-pump discharge pressure during windmilling of I-40 jet-propulsion engine (configurations 1-7). Airspeed based on 100-percent free-stream total-pressure recovery.

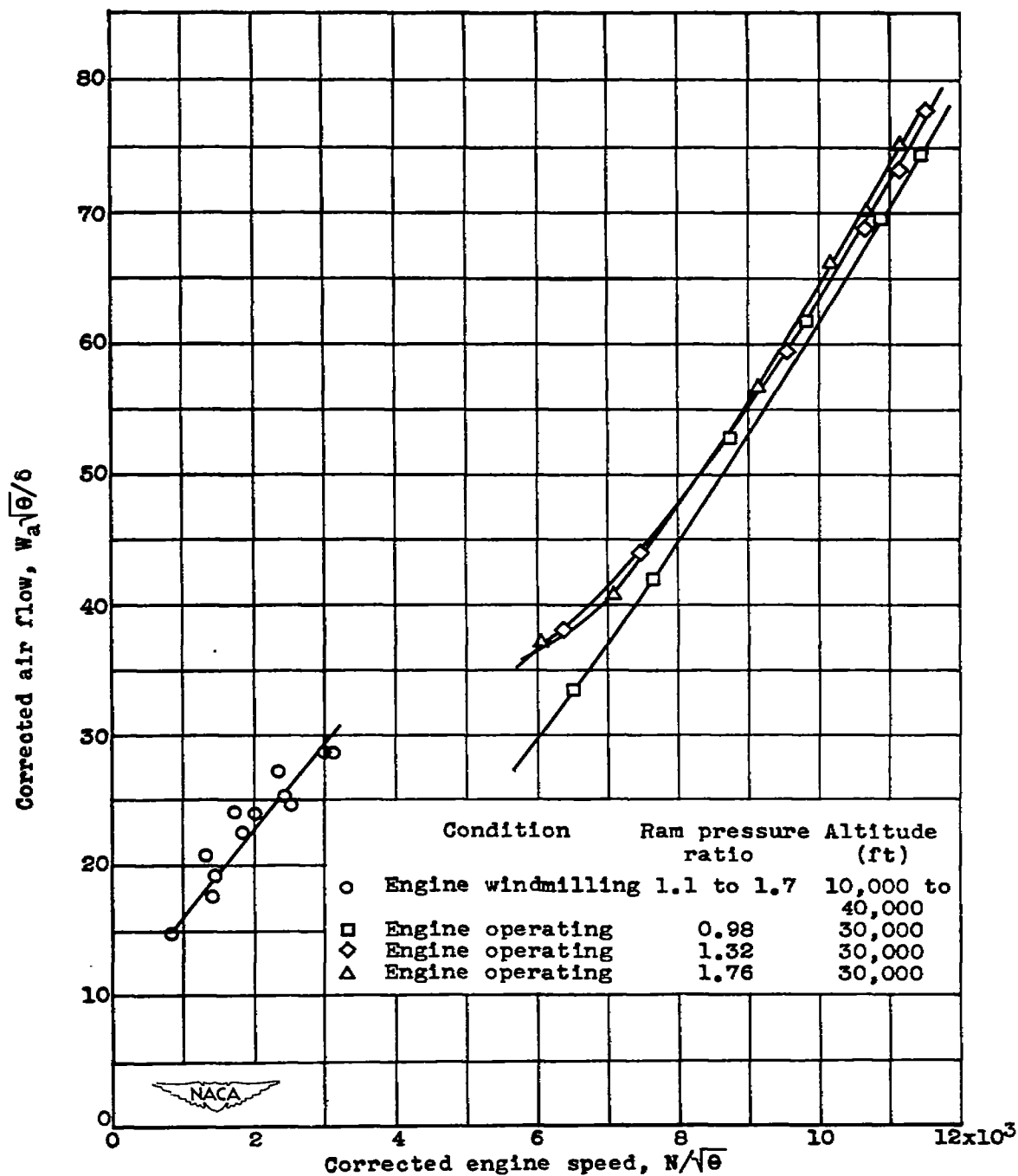
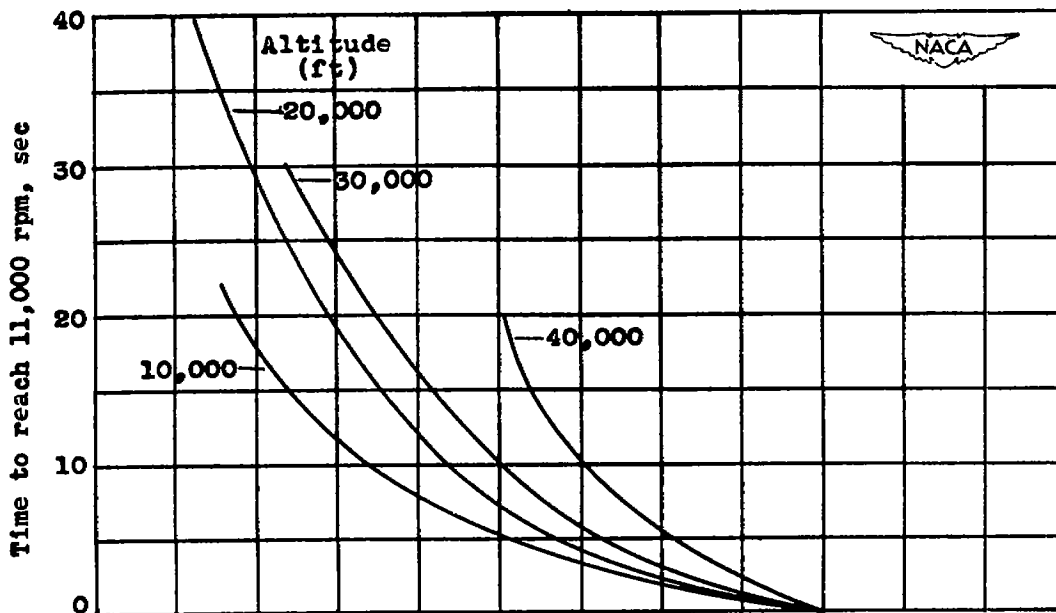
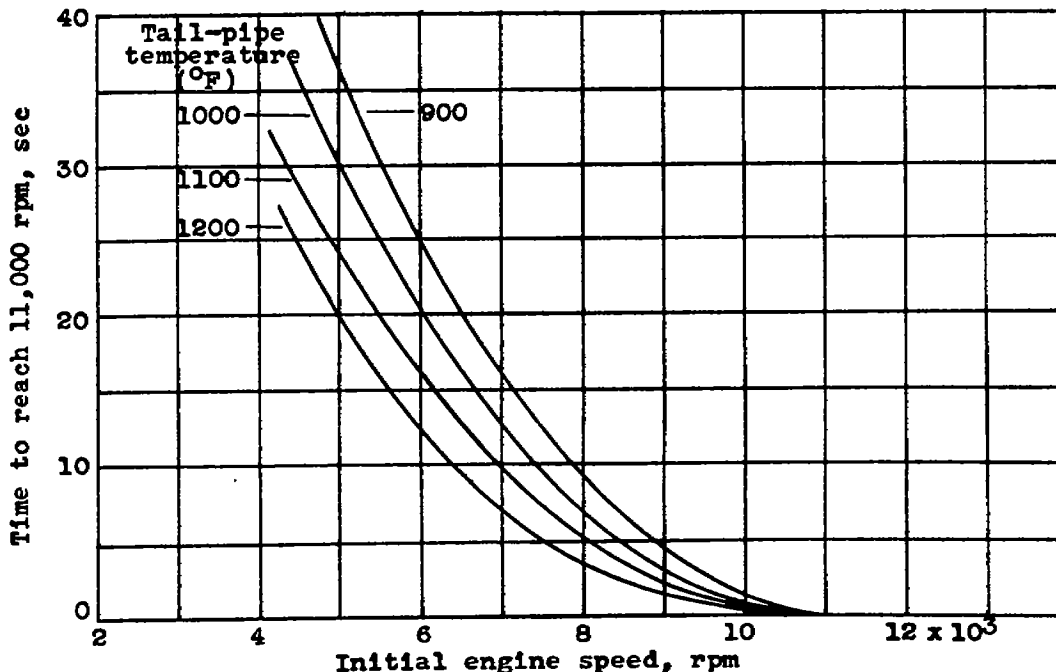

Figure 21.- Comparison of corrected air flows with engine windmilling and engine operating. (Data for engine operating from reference 1, fig.41.)



(a) Effect of altitude at tail-pipe temperature of 1100° F.



(b) Effect of tail-pipe temperature at altitude of 30,000 feet.

Figure 22.- Effect of initial engine speed, altitude, and tail-pipe temperature on acceleration of I-40 jet-propulsion engine equipped with standard barometric and Monarch 40-gallon nozzles (configurations 1-7). Free-stream impact pressure, 40 pounds per square foot.

784

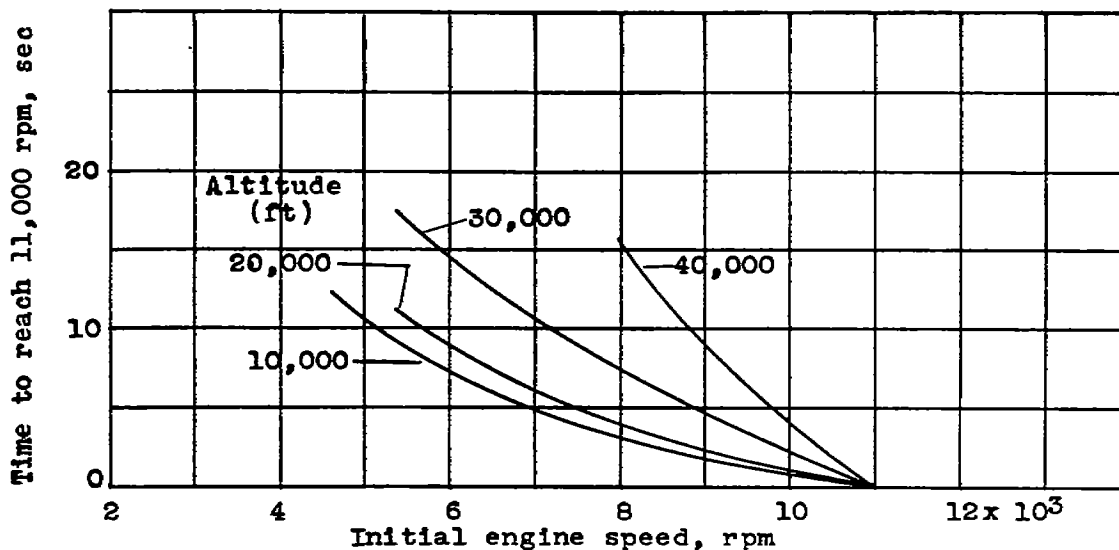

Figure 23.- Effect of initial engine speed and altitude on acceleration of I-40 jet-propulsion engine equipped with standard barometric and Monarch 30-gallon nozzles (configuration 8) at tail-pipe temperature of 1100° F. Free-stream impact pressure, 40 pounds per square foot.

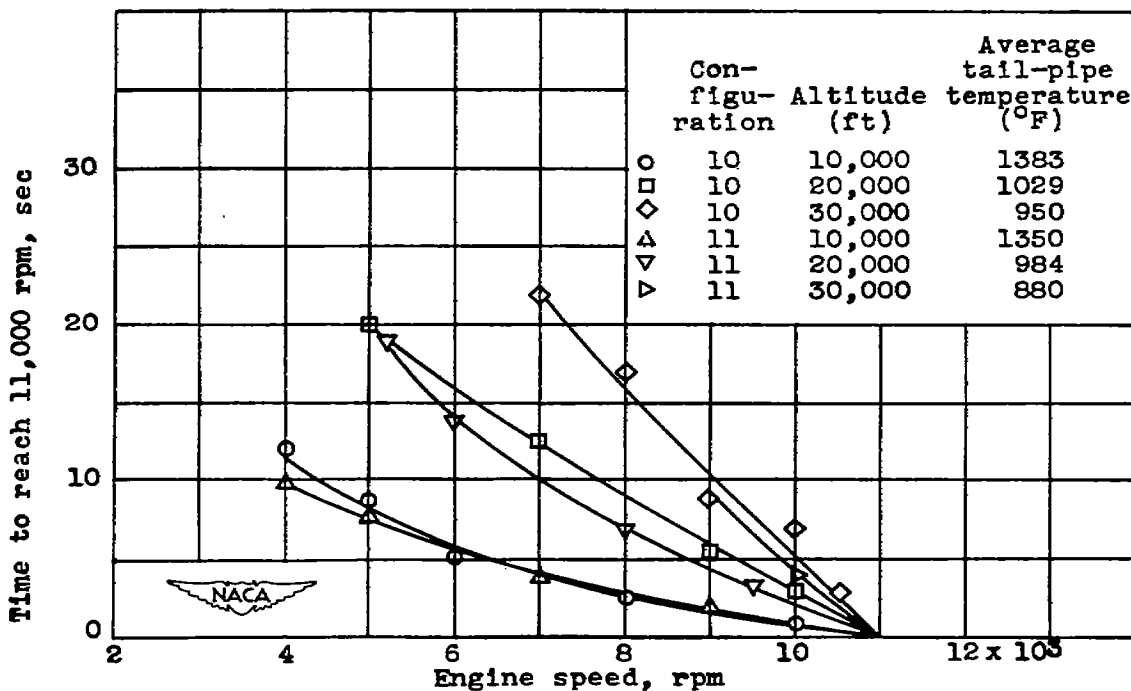

Figure 24.- Effect of change in Edwards regulator on acceleration of I-40 jet-propulsion engine at various altitudes. Free-stream impact pressure, 40 pounds per square foot.

784

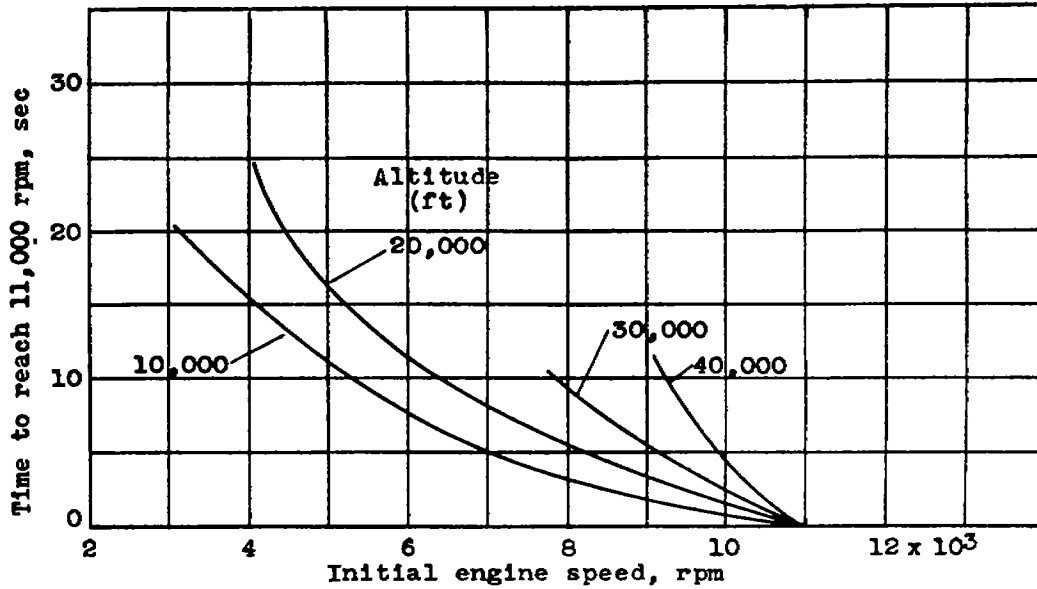

Figure 25.- Effect of initial engine speed and altitude on acceleration of I-40 jet-propulsion engine equipped with Woodward governor and Monarch 30-gallon nozzles (configuration 12). Free-stream impact pressure, 40 pounds per square foot.

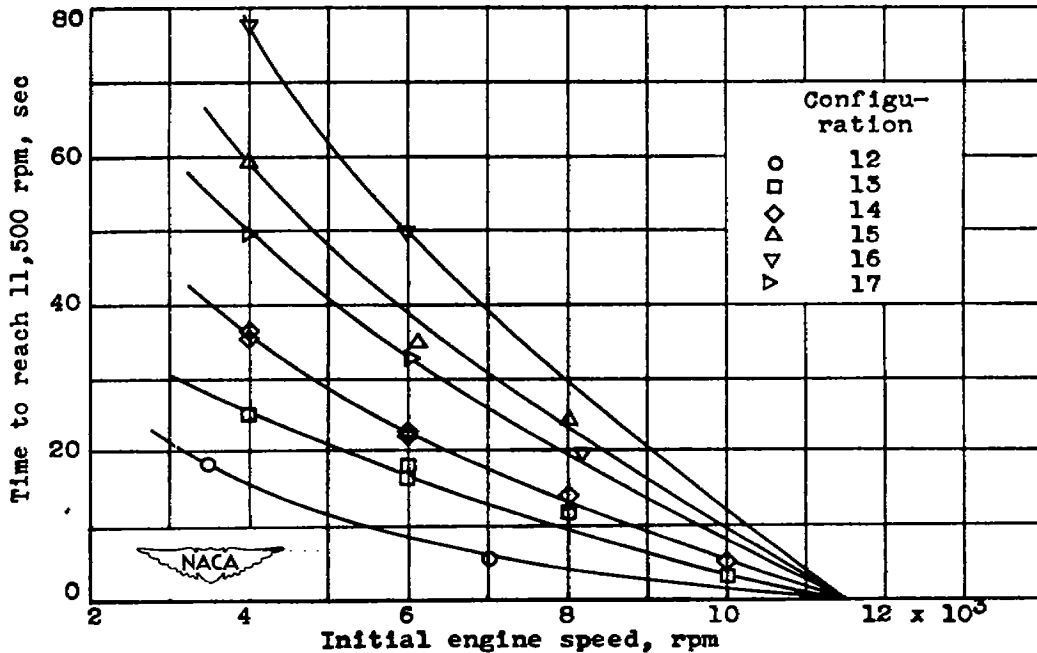
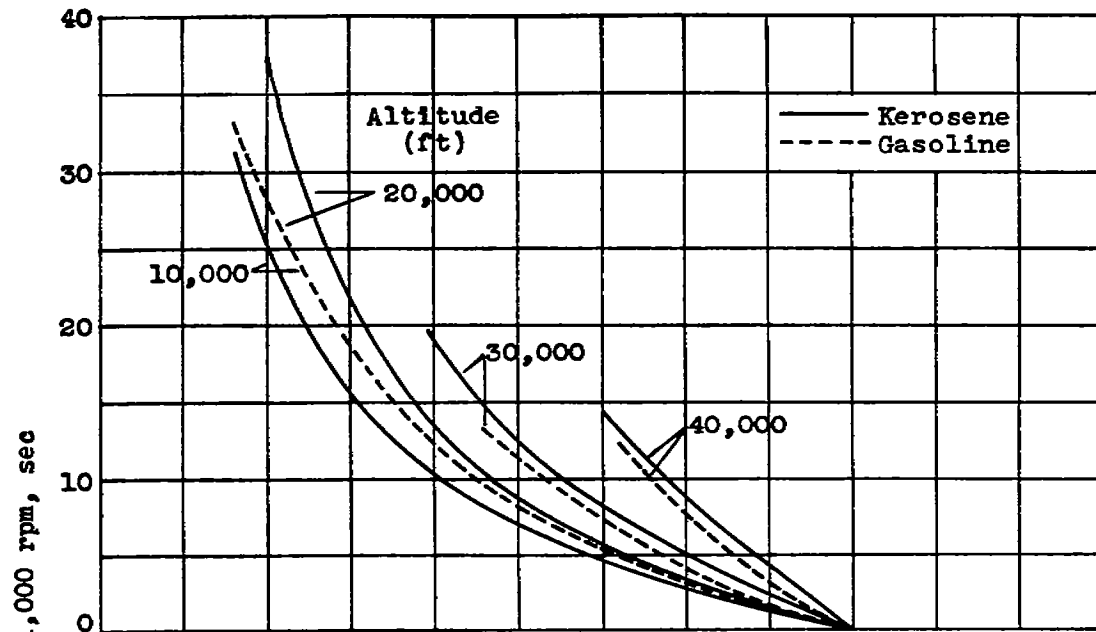
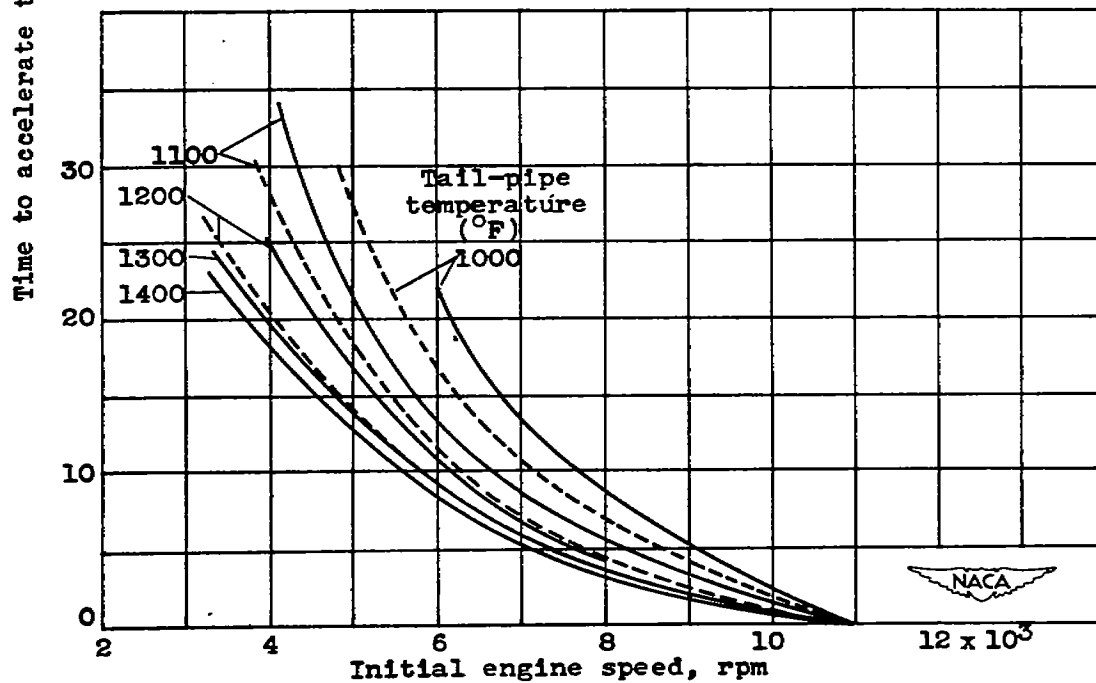

Figure 26.- Effect of initial engine speed and governor adjustments on acceleration of I-40 jet-propulsion engine equipped with Woodward governor at altitude of 10,000 feet. Free-stream impact pressure, 40 pounds per square foot; maximum tail-pipe temperature, 1500° F.



(a) Effect of altitude at tail-pipe temperature of 1100° F.



(b) Effect of tail-pipe temperature at altitude of 20,000 feet.

Figure 27.- Effect of altitude and tail-pipe temperature on acceleration of engine using Syracuse barometric with kerosene and gasoline (configuration 9).

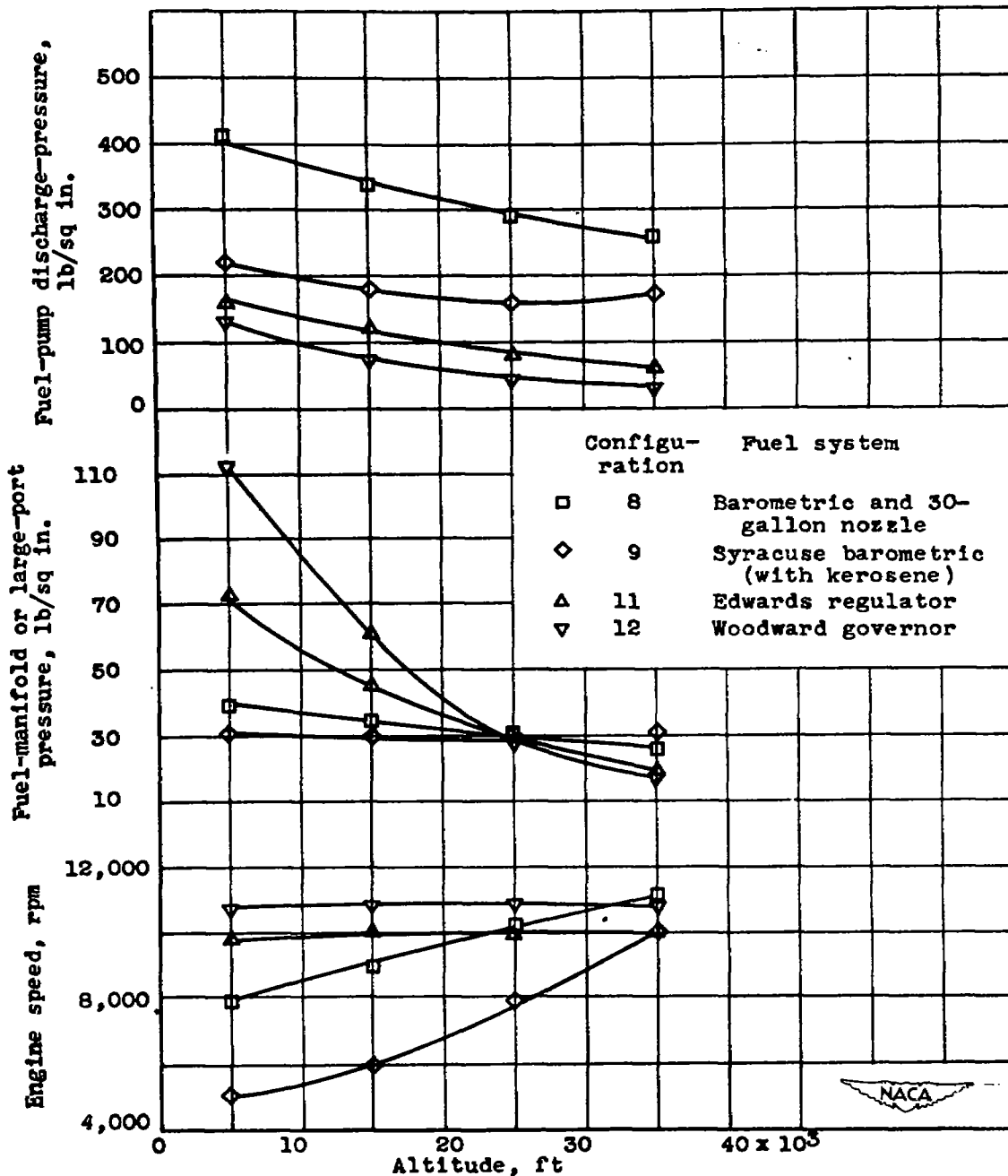

Figure 28.- Effect of altitude on operational variables of I-40 jet-propulsion engine at constant throttle position. Free-stream impact pressure, 40 pounds per square foot.

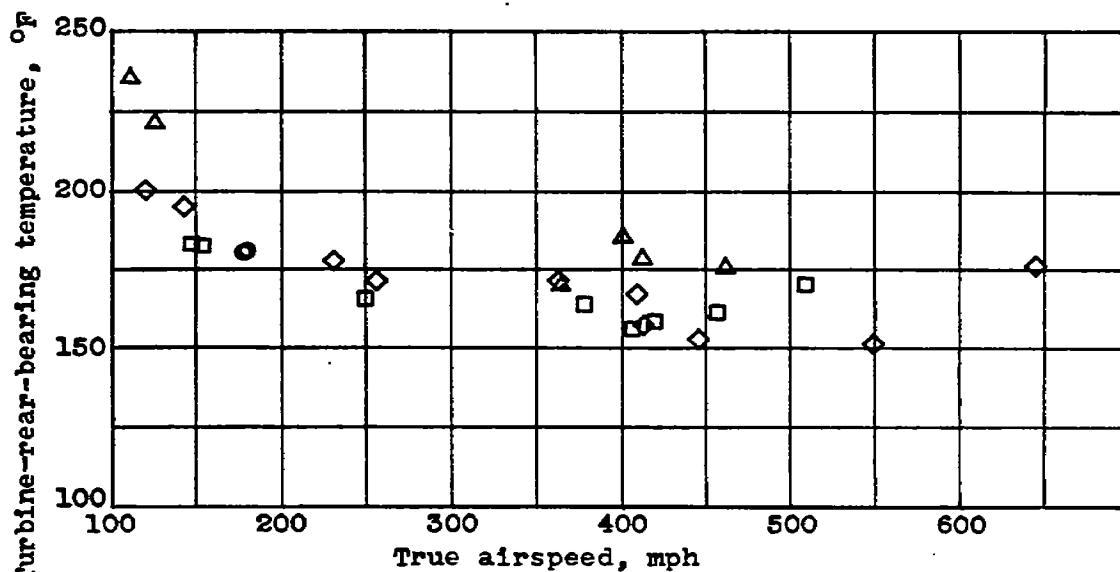

Figure 29.- Effect of airspeed and altitude on turbine-rear-bearing temperature at engine speed of 11,500 rpm. Airspeed based on 100-percent free-stream total-pressure recovery.

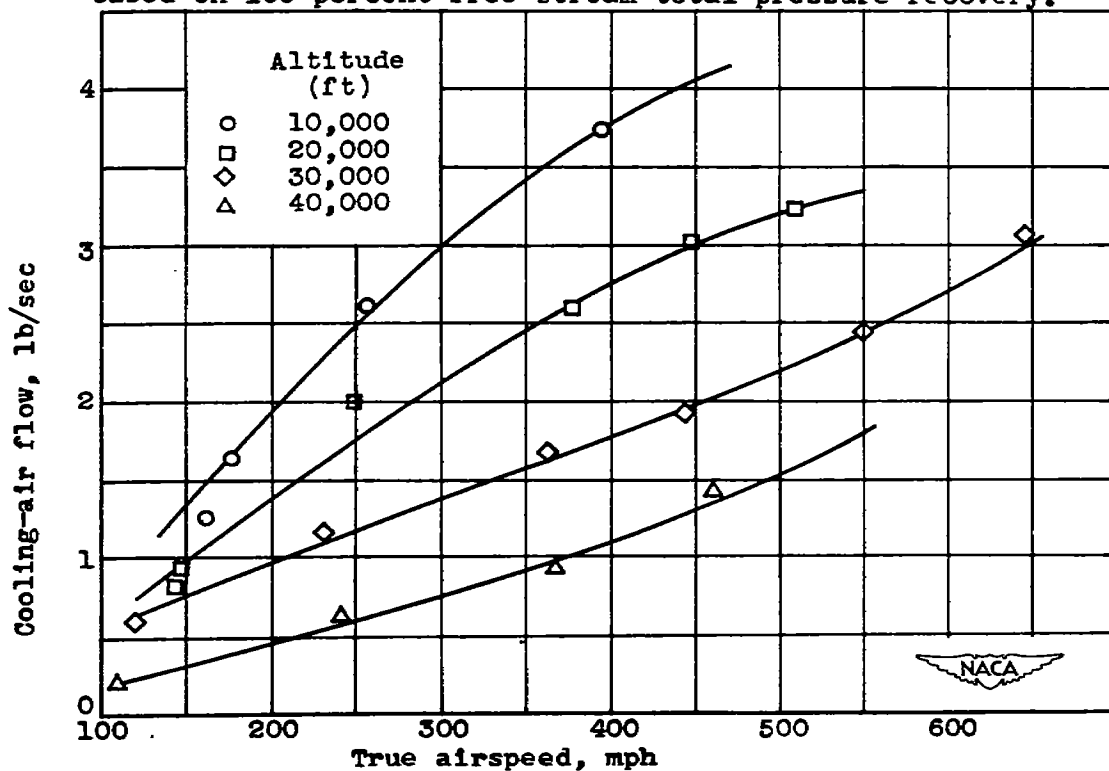

Figure 30.- Effect of airspeed and altitude on total cooling-air flow of I-40 jet-propulsion engine at engine speed of 11,500 rpm. Airspeed based on 100-percent free-stream total-pressure recovery.

784



NACA
C-18876
5-29-47

Figure 31.- View of damage to inner exhaust cone and turbine wheel of I-40 jet-propulsion engine.

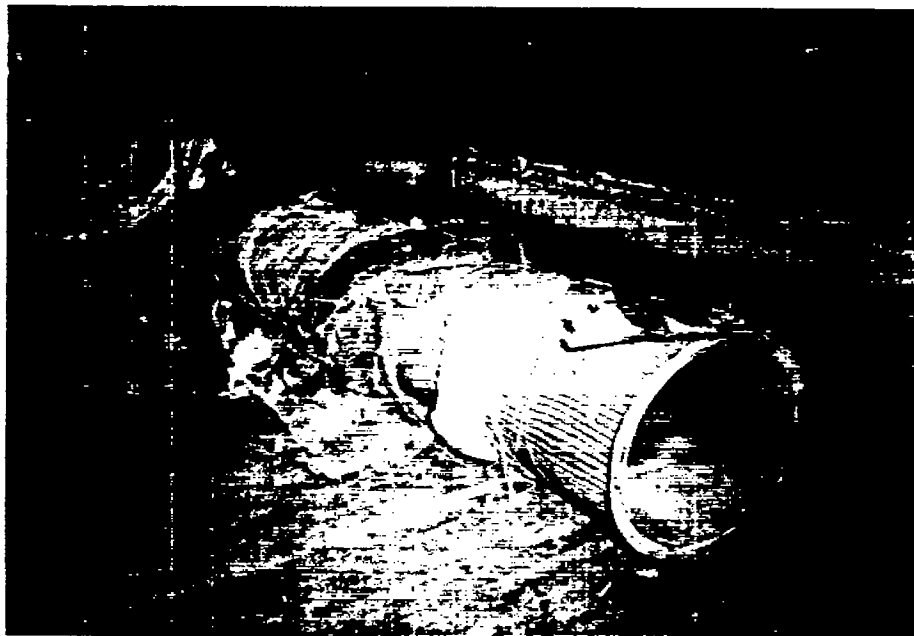
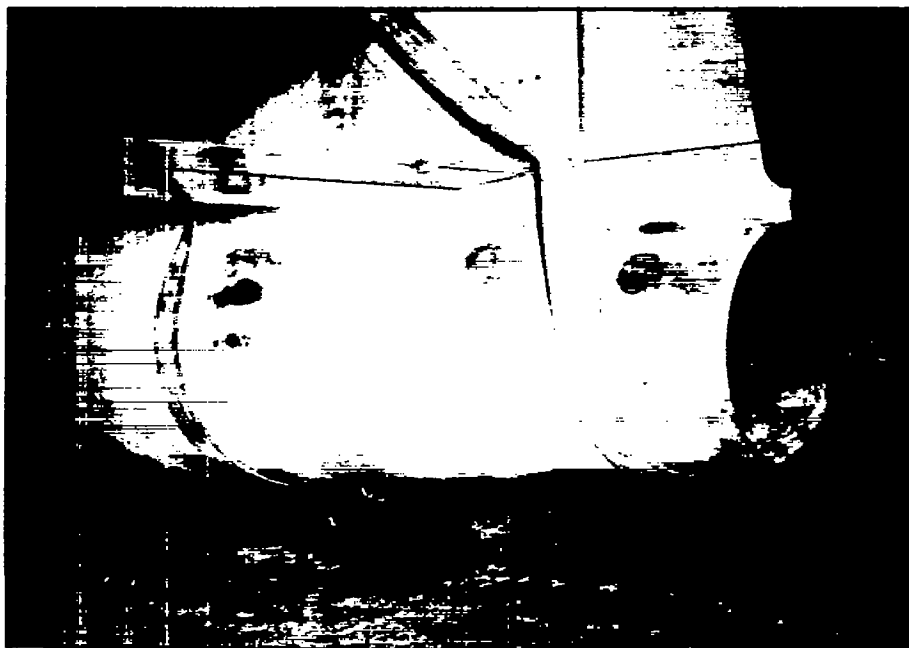

NACA
C-18876
5-29-47

Figure 32.- Views showing damage to fuselage, tail pipe, and tail-pipe insulation of I-40 jet-propulsion engine.

▼

•

•

•

•

- | | |
|----------------------------|------------------------|
| A Fuel inlet | I Bellows top plate |
| B Control valve | J Tension spring |
| C Fuel outlet | K Connection stem |
| D Filter | L Bellows lever |
| E Pilot valve | M Casing |
| F Control piston | N Control-valve spring |
| G Ambient-pressure bellows | O Pivot |
| H Evacuated bellows | P Control-valve area |

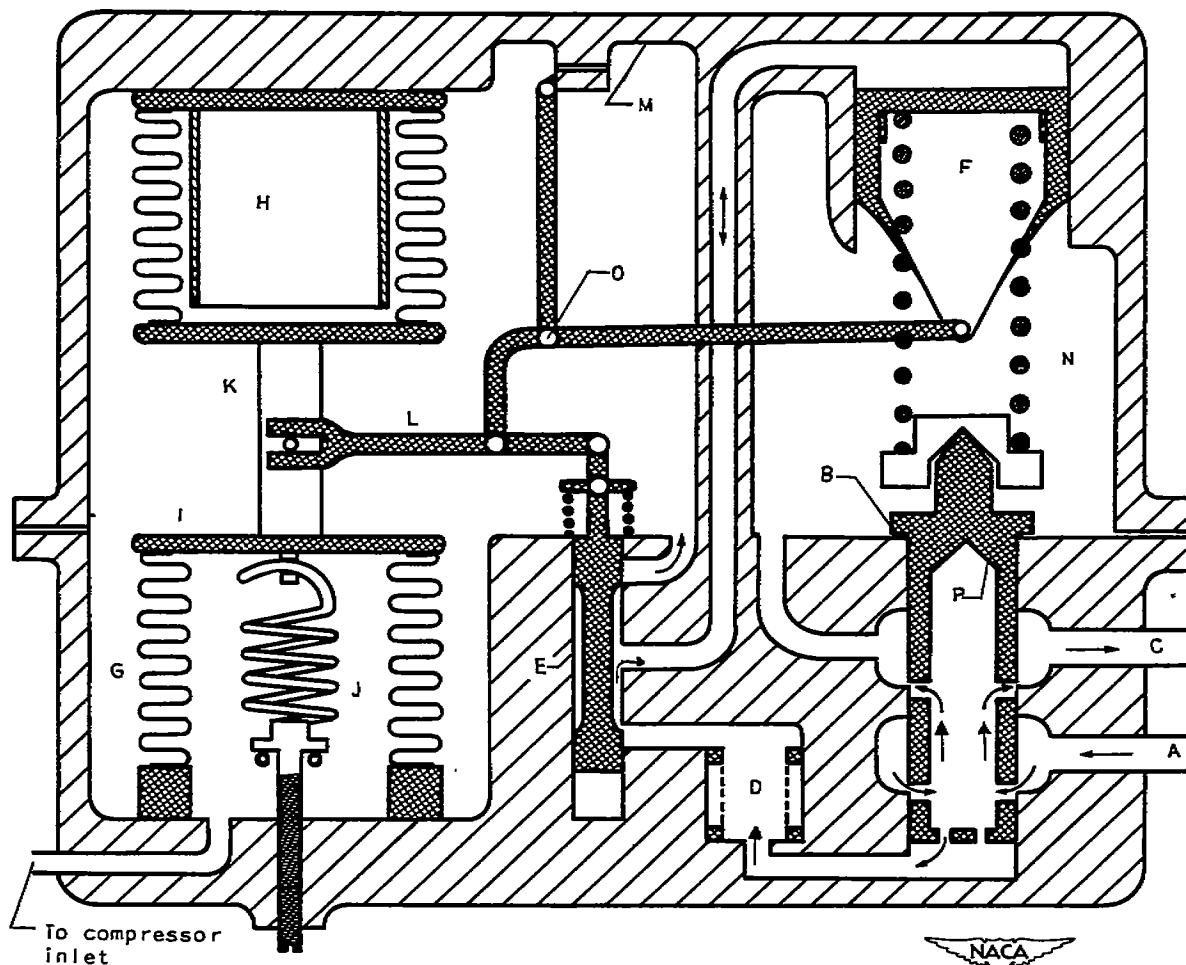

Figure 33.- Diagrammatic sketch of standard barometric fuel control.

- | | |
|---|--------------------------------------|
| 1 Thermal-unit flow-metering device | 15 Bell crank |
| 2 Altitude-compensator flow-metering device | 16 Connecting lever |
| 3 Thermal piston | 17 Altitude-compensator power piston |
| 4 Evacuated bellows | 18 Yoke |
| 5 Altitude-compensator control valve | 19 Recalibrating lever |
| 6 Atmospheric bellows | 20 Roller |
| 7 Thermal unit | 21 Spring lever |
| 8 Fuel regulator | 22 Spring |
| 9 Pilot valve | 23 Control valve |
| 10 Fly weights | 24 Fuel-pressure power piston |
| 11 Governor power piston | 25 Power-piston lever |
| 12 Governor piston lever | 26 Hydraulic relay |
| 13 Governor-adjustment lever | 27 Sundstrand fuel pump |
| 14 Governor-piston bell crank | 28 Oil pump |
| | 29 Variable-control oil line |

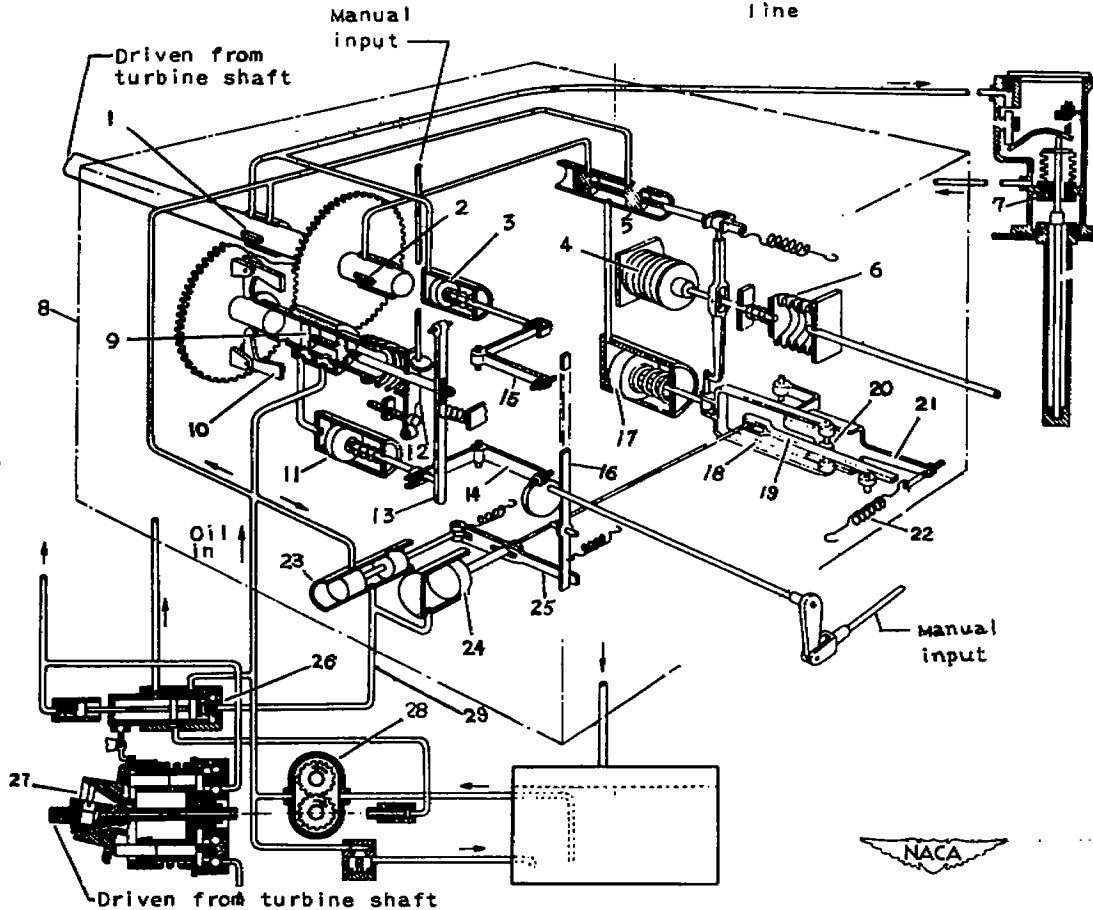

Figure 34.- Schematic diagram of Edwards fuel regulator.

- | | |
|----------------------------------|----------------------------------|
| A Overspeed governor | M Stability-dashpot piston |
| B Dashpot-centering spring | N Pilot valve |
| C Idling-speed stop | O Flyball head |
| D Manual-valve end stop | P Speed-adjustment spring |
| E Manual-valve variable stop | Q Piston |
| F Stability-dashpot needle valve | R Pilot-valve ports |
| G Auxilliary spring | S Control-valve plunger |
| H Flyball spring | T Fuel-control valve |
| I Gear | U Differential-relief-valve area |
| J Variable orifice | V Fuel pump |
| K Acceleration dashpot | W Bypass valve |
| L Acceleration dashpot pin | X Manual-control valve |

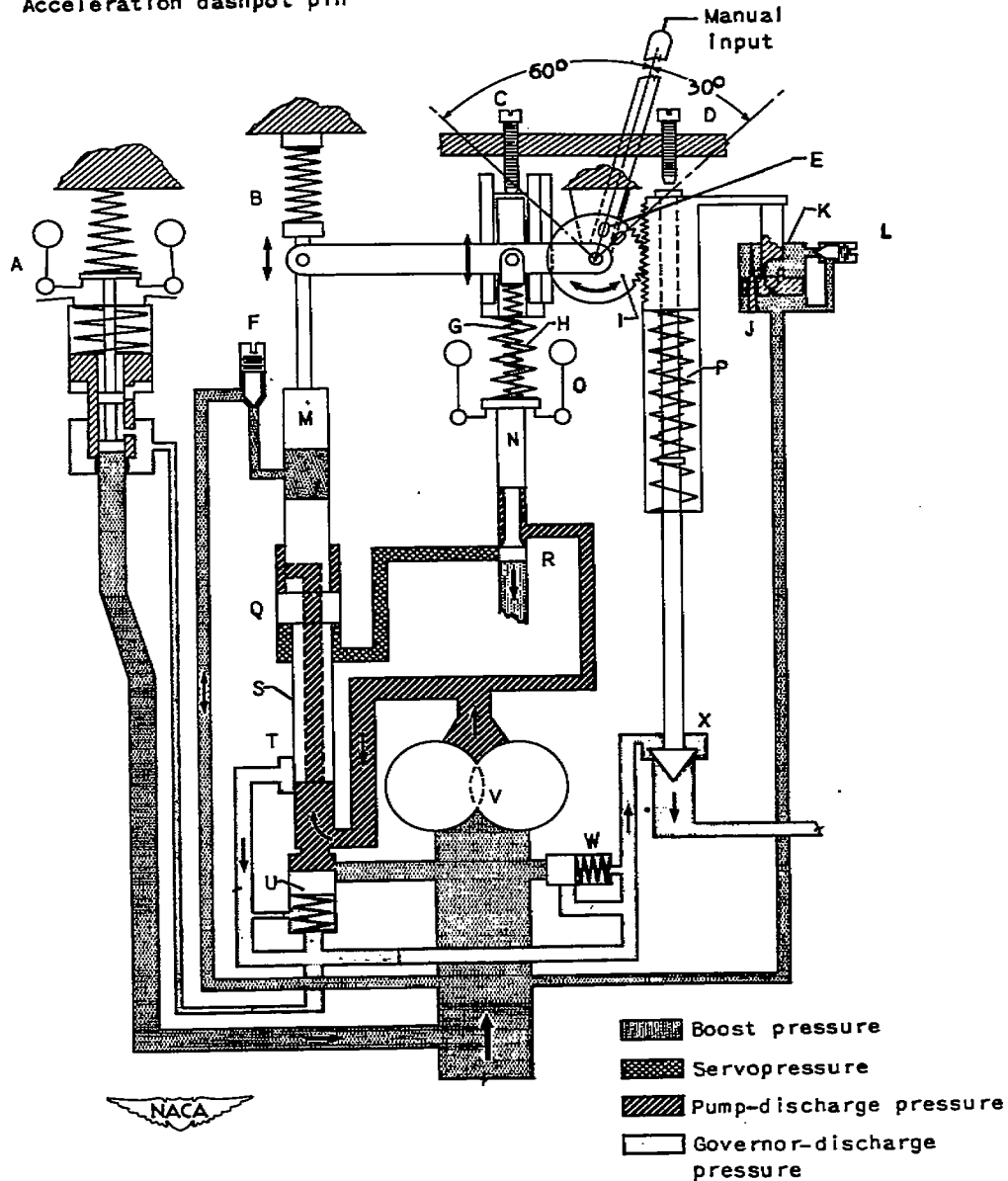

Figure 35. - Schematic diagram of Woodward fuel governor.

784

5+875



3 1176 01435 5490

