

REPORT No. 60

**GENERAL DISCUSSION
OF TEST METHODS FOR RADIATORS**



**NATIONAL ADVISORY COMMITTEE
FOR AERONAUTICS**



PREPRINT FROM FIFTH ANNUAL REPORT

FILE COPY

To be returned to
the files of the Langley
Memorial Aeronautical
Laboratory

WASHINGTON
GOVERNMENT PRINTING OFFICE
1919

3123
4

REPORT No. 60

**GENERAL DISCUSSION
OF TEST METHODS FOR RADIATORS**



**NATIONAL ADVISORY COMMITTEE
FOR AERONAUTICS**



PREPRINT FROM FIFTH ANNUAL REPORT

**WASHINGTON
GOVERNMENT PRINTING OFFICE
1919**

REPORT No. 60

**GENERAL DISCUSSION OF TEST METHODS
FOR RADIATORS**

BY

H. C. DICKINSON, W. S. JAMES, AND W. B. BROWN

REPORT No. 60.

GENERAL DISCUSSION OF TEST METHODS FOR RADIATORS.

By H. C. DICKINSON, W. S. JAMES, AND W. B. BROWN.

INTRODUCTION.

It has been shown in the analysis of the airplane radiator problem that it is necessary to make measurements on—

- (1) The core characteristics which define its nature.
- (2) Heat dissipated, as dependent on—
 - (a) Nature of core.
 - (b) Mass flow of air through the core.
 - (c) Density of the air.
 - (d) Water flow through the core.
 - (e) Temperature difference between the air and water.
- (3) Power needed to lift the radiator and overcome its head resistance, as dependent on—
 - (a) Nature of core.
 - (b) Air speed in the open.
 - (c) Air density.
- (4) Mass flow of air through the core, as dependent on—
 - (a) Nature of the core.
 - (b) Air speed in the open.
- (5) Power needed to circulate water through the core, as dependent on—
 - (a) Nature of the core.
 - (b) Rate of water flow.

Point (5) has been covered by Report No. 63, Part II, and is entirely distinct from the others. The following paragraphs describe (a) the apparatus, (b) the method of taking observations, (c) the method of computing the results, for the first four.

Test Specimens.

The specimens tested for head resistance were plain sections of core without water boxes or other attachments. They varied in size from approximately 6 inches square to approximately 12 inches by 24 inches and 16 inches square.

Those tested for rate of heat dissipation were uniform in size and fittings. The cores were 8 inches square, with water boxes 1 inch deep, as shown in Fig. 1. The entrance and exit water pipes were fitted onto brass tubing $1\frac{1}{2}$ inches deep and $1\frac{1}{2}$ inches in diameter, which were inserted into each water box. Just inside the water box was a baffle of brass to equalize the water flow through the core.

(1) CORE CHARACTERISTICS.

The core characteristics determined were:

- (1) Dimensions of the water tubes, length (parallel to the direction of water flow), depth (parallel to the direction of air flow), thickness (perpendicular to previous two), hydraulic radius (ratio of area of a section perpendicular to the direction of water flow to its perimeter).
- (2) Dimensions of air tubes, depth (same direction as depth above), and hydraulic radius.

- (3) Per cent free area of air passages.
- (4) Extent and distribution of the cooling surface.
- (5) Weight of the core empty and filled with water.
- (6) Nature and thickness of the metal.
- (7) Shape of the air and water passages.

DIMENSIONS OF THE WATER TUBES.

The apparatus used to measure the cross section of the water tubes is shown in figure 2. A radiator specimen, *R*, with water tubes *t-t*, was placed upright on a support. Water from a graduated burette *B* was admitted into the radiator until the water level was a little way above the entrance to the water tubes. Suppose this level was h_2 . This and the water level in the burette *B* were read. The cock *C* was opened and water admitted to the radiator until another level h was reached, when readings of the gauge and burette were taken again. When from 6 to 10 different levels had been observed and a level h_1 , near the top of the specimen reached, the burette was moved to position 1 and readings taken while emptying the radiator.

The burette *B* was calibrated by weighing its water content at different levels. The fine dividing engine of the Division of Weights and Measures was used to calibrate the gauge. This was read (while taking observations) to 0.01 cm. and the volume to 1 cc.

Volumes in cc. were plotted against gauge levels in cm. and the points found to lie on a straight line. If the slope of this line is denoted by m , the area of the water tubes by a , and the area of the gauge by g , then since all the water leaving the burette goes into the radiator and gauge and raises the level of each by the same amount,

$$(1) \qquad m = a + g$$

The constant g was determined previously by using in the gauge known volumes of water.

Two tests were made on each specimen. If the resulting values of a differed more than 3 per cent, other tests were made. The number of water tubes was counted. The depth of the tubes was measured with a rule and calipers. When the water tubes were not vertical, e. g., in the hexagonal cell types, the area above (which is, of course, the horizontal area) was projected onto a plane normal to the direction of the water flow. This projected area divided by the number of tubes gave the area of one tube. A further division by the depth gave the thickness. Twice the sum of the thickness and depth is the perimeter, and this divided into area gave the hydraulic radius. The water-tube length in inches of a foot square section is $12/F$, if F is the above projection factor.

a was expressed in square feet per foot of core width, so that the water content of the core was $62.4 a$, 62.4 being the density of water in pounds per cubic foot.

DIMENSIONS OF THE AIR TUBES.

The method used in finding the cross sectional area of the air tubes was similar to the one just described. The specimen was clamped face down onto the top of a shallow tank 7 inches square and 2 inches deep. The rim of the tank was 1 inch broad and was faced with a strip of soft rubber, so that the edge of the specimen was sealed water-tight. The tank contained two openings to which rubber tubes could be attached, one leading to the burette and the other to the gauge as before.

The observations and computations were exactly the same as in the case of the water tubes. Micrometer measurements on the inside of the air tubes and a direct count of their number determined the perimeter of the air tubes, and when combined with the area above, the hydraulic

GENERAL DISCUSSION OF TEST METHODS FOR RADIATORS.

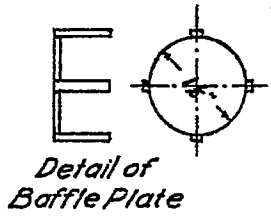
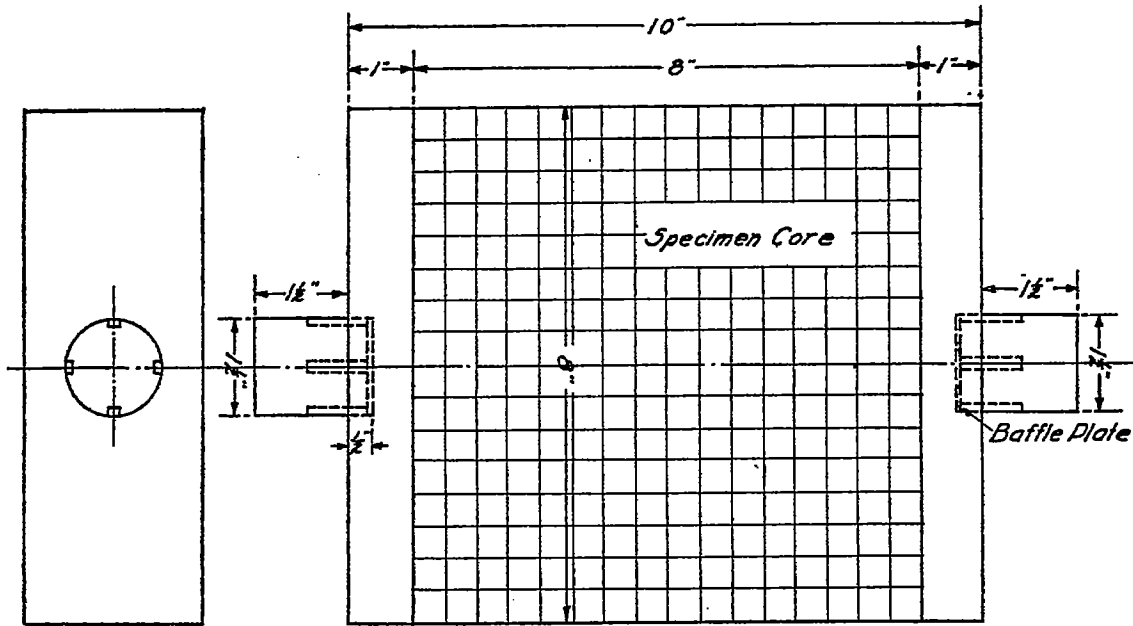

RADIATOR INVESTIGATION
TEST SPECIMEN

Figure 1

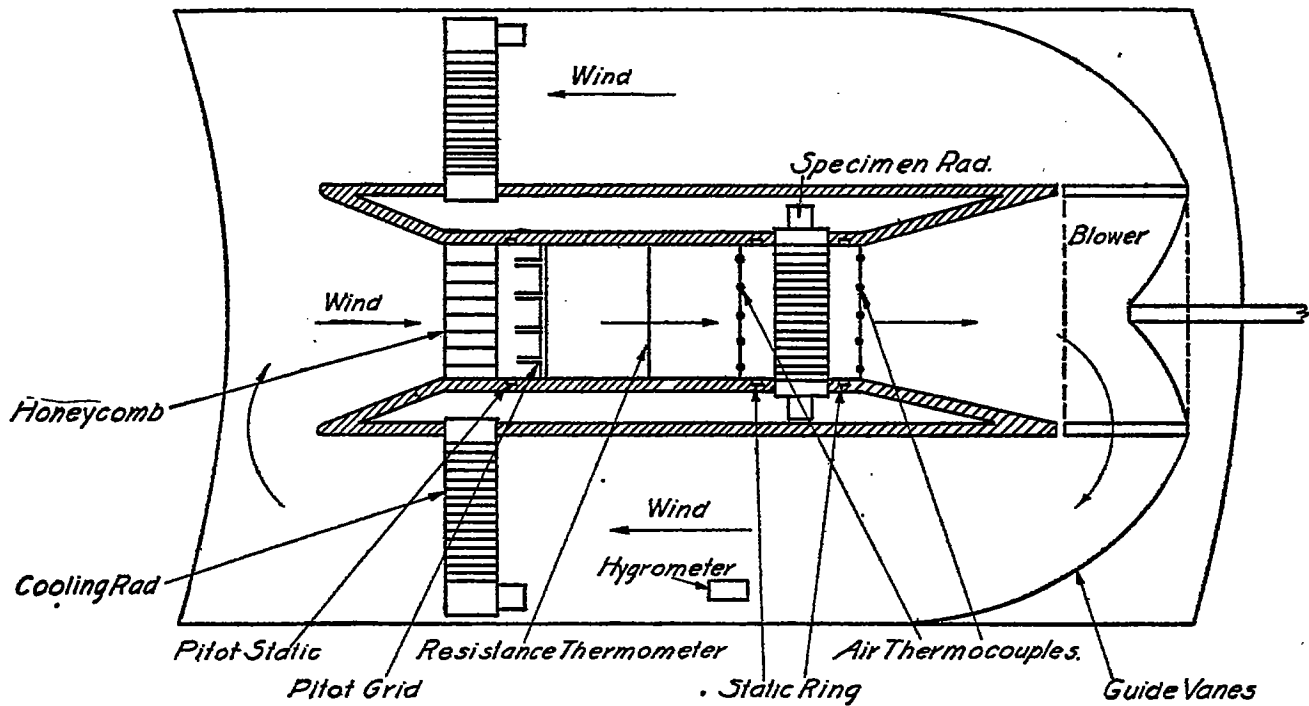

ENCLOSED WIND TUNNEL

Figure 3

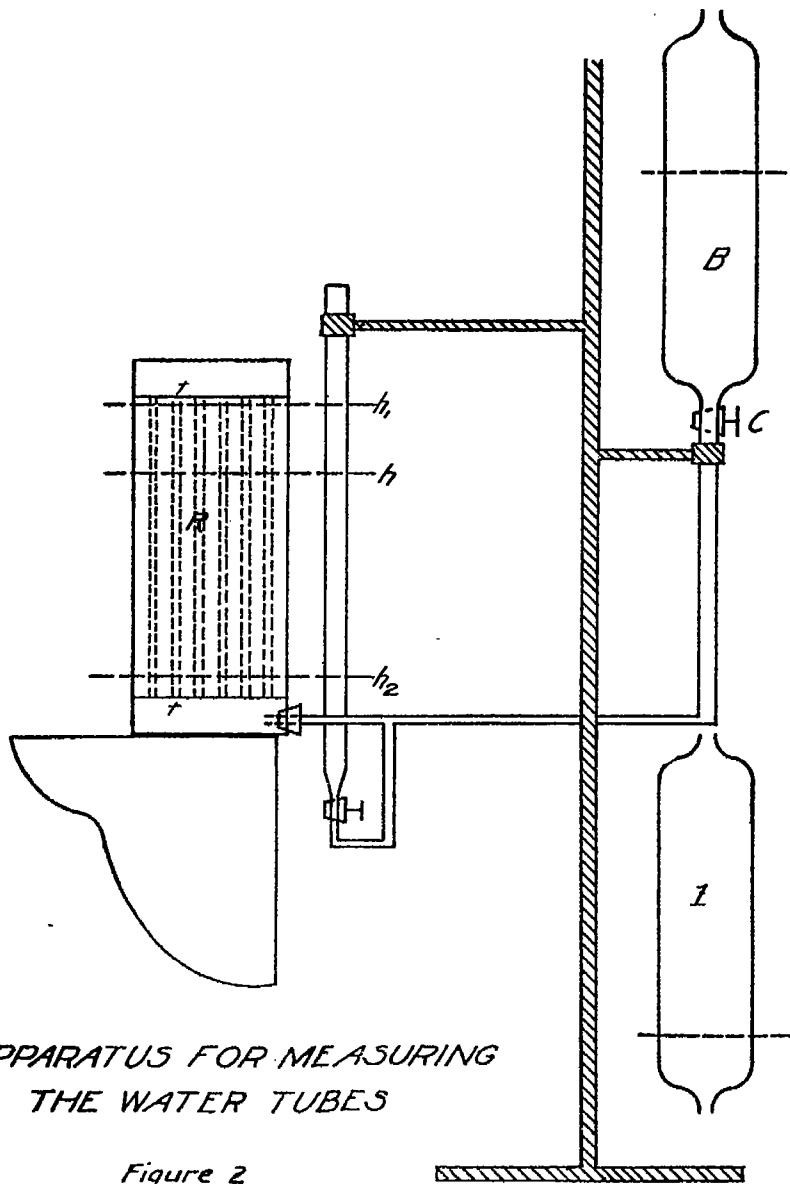

APPARATUS FOR MEASURING
THE WATER TUBES

Figure 2

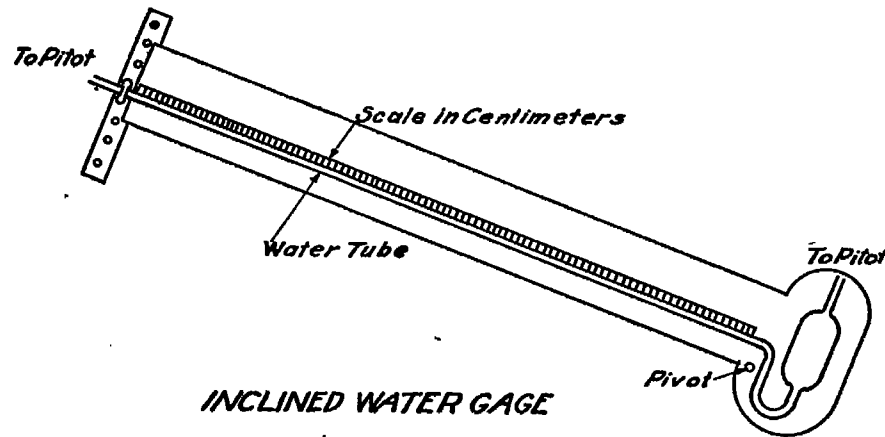

INCLINED WATER GAGE

Figure 4

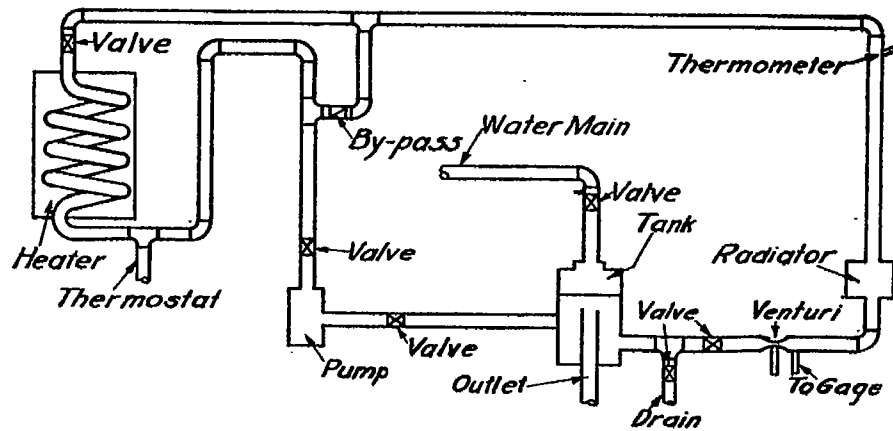

WATER SYSTEM IN VACUUM TUNNEL

Figure 5

radius also. These observations gave an independent value of the air-tube area which agreed well with the results of the above method.

The air-tube depth (identical with the core depth) was measured with a rule and calipers.

FREE AREA OF THE AIR PASSAGES.

Since the specimens were seldom exactly 8 inches square, careful measurements of the true frontal area were made and divided into the air-tube area to give the per cent of free area.

EXTENT AND DISTRIBUTION OF THE COOLING SURFACE.

When the air tubes had a simple shape, circular, hexagonal, rectangular, etc., so that the relation between the area and the perimeter was known, the air-tube measurements above sufficed to determine the cooling surface, since this is the product of the perimeter of a tube by the number of tubes by the core depth. (Note: A slight correction had to be made sometimes on account of the enlargement at the edges.) Inspection of the radiator construction showed what portion of the surface was direct, i. e., formed part of a water tube or water box wall, and what indirect, i. e., received heat from the water only by conduction along a metal fin of some sort. (E. g., in a Harrison hexagonal cell type, two sides of each air cell formed part of a water tube. Hence one-third of this part of the core was rated as direct surface and two-thirds as indirect.) The edges were all rated indirect.

With the irregular shapes, many different methods of solution were used, depending on the nature of the irregularity. Every effort was made to determine these values to 2 per cent, but in a few cases the values could not be fixed with certainty to better than 10 per cent. Two observers worked independently and compared their results, so that large errors were not apt to escape detection.

WEIGHT OF THE CORE.

The weight of the core empty was found by weighing it with the water boxes removed on a balance. The water content added to this gave the weight of the core filled.

NATURE AND THICKNESS OF THE METAL.

All the specimens tested were made of copper or brass, as determined by inspection. The metal thickness was measured with a stage micrometer reading to 0.005 mm. The readings however, were not very uniform, so the values obtained are not accurate to that degree, e. g., two readings would give 0.008 and 0.010 mm.

SHAPE OF THE AIR AND WATER PASSAGES.

This was determined by inspection and some rough measurements and sketched on the curve sheets.

(2) HEAT DISSIPATED.

Two distinct sets of measurements were made on the heat dissipated and two different sets of apparatus used. Both made use of 8-inch square wind tunnels and were made so that the same specimen could be tested in both tunnels without any alterations. One tunnel was inclosed in a tank which could be partially exhausted and used hot water to supply heat to the radiator. The other was an open tunnel in the room and supplied heat by means of steam.

APPARATUS IN THE INCLOSED TUNNEL.

A diagrammatic sketch of this tunnel is shown in figure 3. Air flow was produced by the suction of a 15-inch Sirocco fan driven by a belt from a 220-volt, direct-current shunt motor, rated at $7\frac{1}{2}$ horsepower; 110-volt current could also be used. A further adjustment afforded by rheostats in both field and armature enabled any speed through the tunnel between 15 and 60 miles per hour to be obtained. Both the fan and the tunnel proper were inclosed in a steel

tank 5 feet long and 3 feet in diameter. This was sufficiently air tight to allow the maintenance within it of a pressure of 30 or 40 cm. of Hg.

At the tunnel entrance a honeycomb of sheet-metal cells, 1 inch square and 3 inches deep, served to break up vortices and straighten the air flow. Following this in order came:

- (1) A Pitot grid to measure the air speed.
- (2) A resistance thermometer to measure the air temperature.
- (3) A thermocouple grid to measure the rise in the air temperature as it passed through the radiator.
- (4) A piezometer ring to measure the drop in the static pressure of the air.
- (5) The specimen under test.
- (6) The other piezometer ring.
- (7) The other thermocouple grid.
- (8) The fan.
- (9) Conical guide vanes to deflect the air down the tank.
- (10) A wet and dry bulb hygrometer to measure the humidity.
- (11) A cold-water radiator to cool the heated air.

Water flow was produced by a centrifugal pump driven by a belt from a one-horsepower direct-current shunt motor. The water line is sketched in figure 5. The resistance of the heating coils to the water flow was quite large compared with the rest of the line, so that high rates of water flow (above 11 gals./min.) could only be obtained by opening the by-pass around the heater. A thermostat maintained a constant temperature at the radiator inlet. After the heater followed in order:

- (1) A Hg. thermometer to regulate the thermostat.
- (2) A set of thermocouples to measure the temperature drop in the water.
- (3) The specimen under test.
- (4) The other half of the thermocouple set.
- (5) A Venturi meter to measure the water flow.
- (6) A drain.
- (7) A tank with a free water surface to open the system.

Construction and calibration of the apparatus: The air-flow measurement offered some difficulty. A Thomas meter was first used for the purpose, but owing to the high air speed and very irregular velocity distribution, it proved very unsatisfactory and had to be discarded. In its place was installed the Pitot grid. This contained 16 dynamic openings, one at the center of each 2 inch square section of the tunnel. All these opened into one tube leading to one arm of an inclined water gauge. A piezometer ring measured the static pressure and led to the other side of the gauge. A piece of sheet copper was carefully inlaid in the tunnel for a distance of 6 $\frac{1}{4}$ inches, so that the air passed over a very smooth surface before reaching the piezometer ring. Four square copper tubes were soldered onto the back of this ring 4 $\frac{1}{4}$ inches from its entrance, at the point of the dynamic openings. At $\frac{1}{4}$ -inch intervals all around this, holes $\frac{1}{8}$ mm. in diameter were drilled. The burr was carefully scraped off the holes, and then the holes were cleaned out and smoothed with a hand drill.

One of the inclined water gauges is shown in figure 4. These were calibrated in each position by connecting them in parallel with a V tube containing light oil of a known density. A zero reading (scale reading with zero pressure difference) was taken before and after a run. Both the zero and the calibration remained sensibly constant over a period of many weeks.

A careful exploration of the channel at various speeds over the range obtainable was made with a standard Pitot. This Pitot was moved about at 49 different points spaced regularly over the channel and the velocity as indicated by it and the grid read. Observations were also made on the pressure difference between the static opening on this Pitot and the piezometer

ring. This last varied slightly around zero, showing that the static pressure was constant across the channel within 3 per cent of the velocity head sought. When the velocity was integrated over the channel it was found to agree within 1½ per cent with the velocity indicated by the Pitot grid at all speeds.

A barometer was connected with this piezometer ring so as to read directly the air pressure at the Pitot.

The resistance thermometer was made in the form shown in figure 6. No. 40 nickel wire was used, inclosed in a 0.5 mm. copper tube. This wire was calibrated by the thermometer section of the bureau and found to satisfy the following equation:

$$(2) \quad R = 103.367 (1 + .003414 t + .00000419 t^2).$$

When R = resistance of the wire in ohms.

t = temperature of the wire in °C.

The bridge used to read R was calibrated by the Electrical Division of the bureau and the corrections found to be negligible. A rough calculation showed that the maximum error caused by neglecting the lead resistance amounted to °.15 C. This produced an error of -0.2 per cent in the result.

At first an attempt was made to measure the temperature rise in the air through the Thomas meter and through the radiator with 200 ohm resistance thermometers in which insulated nickel wire was strung on a lattice work of iron wire. Owing to the varying stresses on the wire caused by the air stream, the resistance changed so much as to vitiate the measurements of small temperature differences (about 1° C.).

The thermocouple grids proved much more satisfactory. They each consisted of 25 copper-constantan junctions spaced at equal intervals over the channel.

Calibration showed that they satisfied the following equation:

$$(3) \quad \frac{de}{dt} = .933 + .0022 t$$

or

$$(4) \quad e = .933 + .0011 t^2$$

where e = E. M. F. in millivolts when cold junctions were at 0° C. This E. M. F. was measured by means of a Morris E. Leeds' 15,000-ohm potentiometer, sensitive to 10 microvolts.

The static rings about the radiator were constructed exactly like the piezometer ring described above, save that the copper ring was 2 inches long.

The Venturi was connected to a mercury pressure gauge and the whole contrivance calibrated by weighing the water discharged through it in a known time.

A 10-foot gravity head was originally used instead of the pressure of the pump to produce the water flow through the radiator, but this was discarded because it did not give sufficiently high rates of flow. The pipes were insulated with magnesia pipe lagging 1 inch thick.

Many methods of arranging the thermocouples so as to measure accurately the temperature drop in the water were tried before a successful one was found. A single couple in the inlet and outlet pipe proved too erratic. Four couples in series in the center of the box itself failed to give a good temperature integration besides giving such a small reading that it was much affected by small thermal E. M. F.'s in the line. Twenty-one couples arranged in three groups of seven each, one in the center of the water box and one on each side, gave very good readings and a good temperature integration but proved too fragile to withstand the hard usage received in changing specimens.

Finally 21 couples, about one-half inch apart, were incased in a copper tube in the form of a spiral coil and placed in the inlet and outlet water pipes. These proved very successful in every respect.

They measured only the temperature drop in the water. To measure the absolute temperature of the water, an extra constantan lead from the first junction ran to a cold junction placed in an oil bath outside the tank (see fig. 7). The temperature of this bath was measured by a mercury thermometer graduated to 0.1° C., which had been calibrated by the thermometer section of the bureau.

The single couple just referred to and the 21 couples in series were calibrated separately and found to satisfy the following equations respectively:

(5)
$$e = 39.10t + .04t^2$$

(6)
$$e = 39.97t + .0314t^2$$

e is here expressed in microvolts per couple, t in degrees C.

Method of observing.—The machinery was first set in motion and allowed to run until the temperature conditions became steady. Two observers worked simultaneously, one reading the electrical instruments that measured the temperatures, the other reading the pressure gauges and the hygrometer. The sample observation sheets, figures 8 and 9, give such a set. The time of each observation was recorded in small figures above it.

After complete readings had been taken under one set of conditions, one of them was changed and another set of readings taken. A complete set of observations on one specimen included sets under atmospheric conditions with constant water flow and varying air speeds; with constant water and air flow, but varying air speeds and pressures; with different constant air speeds, but varying water flow. A special set was taken on one specimen under atmospheric conditions with constant air and water flow, but with varying inlet water temperatures.

Method of computing results.—The given data, figure 10, sufficed to determine:

- (1) Pressure drop in the air through the radiator lb.-wt./ft.²
- (2) Rate of water flow in gal./min./ft. width of core and speed in ft./min.
- (3) Rate of air flow in lb./sec./ft.² frontal core area.
- (4) Air density in lb./ft.³
- (5) Heat given up by the water in horsepower per 100° F. difference between mean temperature of water and entrance temperature of the air per square foot frontal area of core.
- (6) Heat received by the air in same units.

These results were used to plot the following curves:

	Ordinate.	Abscissa.	Constant.	Constant.
(a)	(5)	(3)	(2)	(4)
(b)	(6)	(3)	(2)	(4)
(c)	(6)	(2)	(3)	(4)
(d)	(6)	(4)	(2)	(3)
(e)	(1)	(3)	(4)	
(f)	(1)	(4)	(3)	

The computation sheet (fig. 10) exhibits the details of the computation. The explanation follows:

Pressure drop.—This equals a conversion factor \times gauge reading.

Water flow.—Let H = Venturi reading

W = water flow in gals./min./ft.

V = water speed in ft./min.

S = water density in g./cc.

A = water tube area in cm.²

DATA SHEET

VACUUM TUNNEL LABORATORY

BUREAU OF STANDARDS

* Gage Readings *

COMPUTATION SHEET FOR VACUUM TUNNEL

***** BUREAU OF STANDARDS *****

Run No. 716 Section # 45
Mc Cord Radiator Date 6-20-70
 Observer W.N.H. Motor R.P.M. 750

Mc Cord Radiator Section # 45
 Calculator W.B.B. Observers L.E.V. W.N.H.

Time	Venturi (cm Hg)	Temp Press. Vent C	Temp. Drop cm	P.D. gage C	Pitot Temp cm	Hygrometer pitot Wet C	Dry C	Barometer Hg cm	temp C
4 ^h	Left	30.0	29.5	18.10	00.5	0.79	30.5	Left 67.10	
	Right							Right 27.85	30.5
	Left							Left 67.00 (4)	
	Right	30.1		18.21		0.73	30.1	Right 27.27	
	Left							Left 67.01 (7)	
	Right	30.0		17.70		0.59		Right 27.31	
	Left							Left	
	Right							Right	
	Left							Diff. bett	32.05
	Right							" Right	32.01
	Left							" Left	32.70
	Right							Right	
	Left							Left	
	Right							Right	
	mean Left	30.03		18.05		0.70		mean Left	32.70 mm
	Zero Right	37.53		2.45		4.55		corr. Right	-2.6
	True height	10.50		15.60		4.15		True bar.	32.5

Run No.	714	715	716
Date	6-20		
Time	3:40	3:50	4:04
Wet bulb C		41.0	38.1
Dry bulb C		56.0	56.9
T		0.00	0.10
76 - P cm. Hg.		27	36
Correction to % humidity		2	4
Apparent % humidity		41	32
% humidity		43	36
Temp. air at entrance C	34.9	35.1	35.4
Mean temp. water C	25.1	24.7	24.2
Pressure mm. Hg	593	493	325
Density of dry air lb/ft ³	0.0558	0.0464	0.0371
Humidity correction "	0.0017	0.0017	0.0016
Density of air	0.0541	0.0447	0.0355
Pitot constant	3.94	3.94	3.94
Pitot reading	2.76	3.14	4.15
Air flow lb/sec/ft ²	1.52	1.48	1.51
Air temp. rise mv.	171.0	174.00	170.6
Air temp. rise C	16.67	16.31	16.52
Temp. cold junction mv	132.2	130.0	132.6
Water inlet temp. mv	280.5	280.5	276.0
-1/42 water couple mv	2.46	4.5	4.6
Mean water temp. mv	400.1	406.0	404.0
K	1307	1308	1309
Water couple mv	134.4	130.8	132.2
Mean water - entrance air C	60.2	53.6	58.0
Venturi gage cm. Hg	10.37	10.47	10.50
Heat lost by water HP/ft ² /100 F	14.41	14.36	14.70
Heat received by air "	14.65	14.61	14.75
Water velocity constant	24.8	24.8	24.8
Water velocity ft/min	80.0	80.4	80.5
Water flow gal/min/ft	15.00	15.15	15.17
Air pressure drop lb/ft ³	4.25	4.90	5.47

Remarks:

Remarks :

Figure 9

Figure 10

then the Venturi formula gives—

$$(7) \quad W = 4.69 \sqrt{HS}$$

$$(8) \quad V = 386.2 \sqrt{\frac{FH}{a^2}}$$

where 4.69 is a factor found by calibration, F is a factor found by calibration to reduce gauge readings to cm. Hg., its value being 1.008. 386.2 is a computed conversion factor.

All the gauges had temperature coefficients, but these gave rise to negligible corrections over the annual temperature range of the room.

Air density.—Let P = air pressure at the Pitot in mm. Hg.

t = air temperature at the Pitot in °C.

d^1 = density dry air at the Pitot in lbs./ft.³

then the gas laws as applied to air gave

$$(9) \quad d^1 = \frac{.029P}{t+273}$$

In addition let d = true density of air in lb./ft.³ and $d = d^1 + C$.

It follows from the laws for mixtures of gases and vapors that

$$(10) \quad C = R \left(S_2 - \frac{.029 e_2}{t+273} \right)$$

Wherein R = relative humidity.

S_2 = density of saturated water vapor at t °C in lb./ft.³

and e_2 = pressure of saturated water vapor at t °C in mm. Hg.

R was found from the wet and dry bulb readings by means of an ordinary chart for the purpose. In the case of the reduced pressure runs, the value found thus required a correction r derived from the formula of W. H. Carrier (A. S. M. E. Trans., 1911, pp. 1005 et seq).

$$(11) \quad r = (76-P) T$$

$$(12) \quad T = \frac{t-t^1}{(2803-1.33t)e_2}$$

if t and t^1 are dry and wet bulb temperatures, respectively, in °F. (This is the T appearing in the sixth line of the computation sheet.)

Air flow.—Let M = Air flow in lb./sec./ft.²

h = reading on the Pitot gauge

A = Pitot constant

F_1 = factor to convert the reading to g./cm.²

then the Pitot formula gives,

$$(13) \quad M = A \sqrt{hd} \text{ where } A = 11.49 \sqrt{F_1}. \quad 11.49 \text{ is a conversion factor.}$$

Heat received by the air.—Let

$\left(\frac{de}{dt} \right)_m$ = slope of e - t curve at mean temp. of air in radiator.

and De = E. M. F. between air inlet and outlet couples in millivolts.

Q_a = heat received by the air in H. P./ft.²/100° F.

Dt = temperature rise in the air in °C.

C = specific heat of the air at constant pressure.

$$(13a) \quad \text{then } Dt = \frac{De}{\left(\frac{de}{dt} \right)_m} \text{ because (4) is a parabolic equation.}$$

From the definition of Q_a it follows that

$$(14) \quad Q_a = \frac{141.4 C_p \cdot M \cdot Dt}{t_w - t}$$

Wherein t_w = mean temperature of water in °C. and 141.4 is a conversion factor.

$C_p = 0.246$ according to W. C. Rowse (A. S. M. E. 1913), for 40° C. and 40 per cent humidity.

Heat lost by the water.—Let

e_o = the E. M. F. between 0° C. and the temp. of the oil bath (microvolts/couple)

De = the E. M. F. between oil bath temp. and that of inlet water.

De_w = the E. M. F. between water temp. at inlet and at outlet.

e_w = the E. M. F. between 0° C. and mean temp. of water.

Q_w = the heat lost by the water in H. P./ft.²/100° F.

If now in place of the E. M. F. corresponding to the mean water temperature is put the average E. M. F. of the couples in the water stream at the entrance and exit of the specimen there results

$$(15) \quad e_w = e_o + De - \frac{De_w}{42}$$

The error due to this substitution never exceeds 0.09° C. and was usually about 0.001° C. t_w was found by equation (5)

For this case there are two equations similar to (13a) and (14) for air. If for M in (14) is put its value as given by the Venturi equation (7), and for Dt its value as given by (13a), the result is:

$$(16) \quad Q_w = \frac{KD e_w \sqrt{H}}{t_w - t}$$

Where
and

$$K = K^1 + DK$$

$$K^1 = \frac{.701 \times 196.21 C_w \sqrt{FS_w}}{n \left(\frac{de}{dt} \right)_w}$$

and

$$DK = \frac{.0427 De_w \sqrt{F}}{n^2 \left(\frac{de}{dt} \right)_w^2}$$

.701 converts $g.$ cal./sec./deg. C/8-inch sq. frontal area to H. P./ft.²/100° F.

196.21 converts cm./Hg on the Venturi to cc./sec.

C_w = Specific heat of water at t_w ° C.

S_w = density of water at t_w ° C.

n = number of thermocouples (here 21).

DK is a small correction less than 0.5 per cent of K , which allowed for the fact that the Venturi was at the water outlet and hence S was greater than S_w by an amount proportional to Dt , the temperature drop in the water. In practice K^1 was tabulated as a function of t_w and abbreviated the computation.

APPARATUS IN THE STEAM TUNNEL.

The steam tunnel was open and not inclosed like the one just considered. A sketch of it is shown in figure 11. Air was pushed through the tunnel by a 36-inch Sturtevant Blower driven by a 220-volt direct current shunt motor rated at 10 horsepower. Adjustable rheostats in both field and armature gave a range of speeds from 30 to 100 miles per hour when the channel was unobstructed. By blocking up the air intake the speed was further reduced to 10 miles per hour. A mercury thermometer inserted through the tunnel wall measured the air tem-

peratures to 0.°5 C. A Pitot grid and two piezometer rings were installed just as in the inclosed tunnel. In addition two other rings 7 inches from the radiator faces were used.

The barometer was in the room, so that observations had to be made on the pressure difference between the air in the tunnel and in the room. This was accomplished by opening the low-pressure side of the pressure drop gauge to the air in the room.

A recording hygrometer registered the humidity with sufficient accuracy.

The heat dissipated by the radiator was supplied by the condensation of dry steam. Figure 12 gives a sketch of the apparatus used to control and measure the steam flow. Steam from the high-pressure mains (100 lbs./in.² was passed through a valve where its pressure was reduced to about 10 lbs./in.². A V-shaped pipe with an opening at the bottom drained out most of the water. The steam passed on through a coil where it was superheated about 50° C., through a plug cock where its pressure fell to atmospheric, through a separator where a mercury thermometer recorded its temperature, through the radiator specimen where most of it condensed and through another separator out of which the water dropped into a weighing tank.

Originally a thermometer was inserted in the lower water box of the specimen, but the water temperature was found to differ so slightly from the temperature of condensation that the heat lost by the water in cooling could be safely neglected. A fan blew the steam away from the tunnel. The steam line was insulated in the same manner as the water line in the other tunnel. The radiator specimen was insulated on the sides with cork board one-half inch thick. The water boxes were not so well protected, but on account of the small surface exposed and the comparatively quiet air in contact with them, the heat lost thus could not have been more than a few tenths of a per cent at moderate speeds. In fact, in some of the early experiments, the steam condensed when the channel was blocked so no air flow existed was measured and found to be less than 1 per cent of the total.

Method of observing.—The exhaust valves in the steam line were opened, the water drained off and the blower started. When the water was out of the line and the steam flowing well, the gas heater was lighted, and the blower adjusted to give the desired speed. After steady conditions of steam flow and temperature had been attained, one observer set the balance slightly ahead of the actual weight and started a stop-watch when the pointer crossed the zero line. The balance was set ahead of the weight (from 1 to 10 pounds, according to the probable rate of condensation), and one observer from then on recorded steam temperatures. At the same time the other observer read the gauges and the air temperature. A set of readings was taken at regular intervals (every one or two minutes, according to the duration of the run). About a minute before the assigned weight was reached, a bell warned the observers, who prepared to observe the time when the pointer crossed the line again. At each speed two or three runs were taken as a check. The time interval employed was from three to six minutes, and could easily be measured to 1 second. The balance weighed correctly to 0.01 pound. An observation sheet (fig. 13) is reproduced.

Method of computing results.—As in the case of the inclosed tunnel the observed data sufficed to determine—

- (1) Pressure drop in the air through the radiator.
- (2) Rate of air flow.
- (3) Heat given up by the steam.

Pressure drop.—This result was computed as in the other tunnel with one addition. Because the piezometer rings were 7 inches from the radiator, (1) was corrected by subtracting from it the pressure drop in 14 inches of unobstructed channel.

Air flow.—The computation was the same as before.

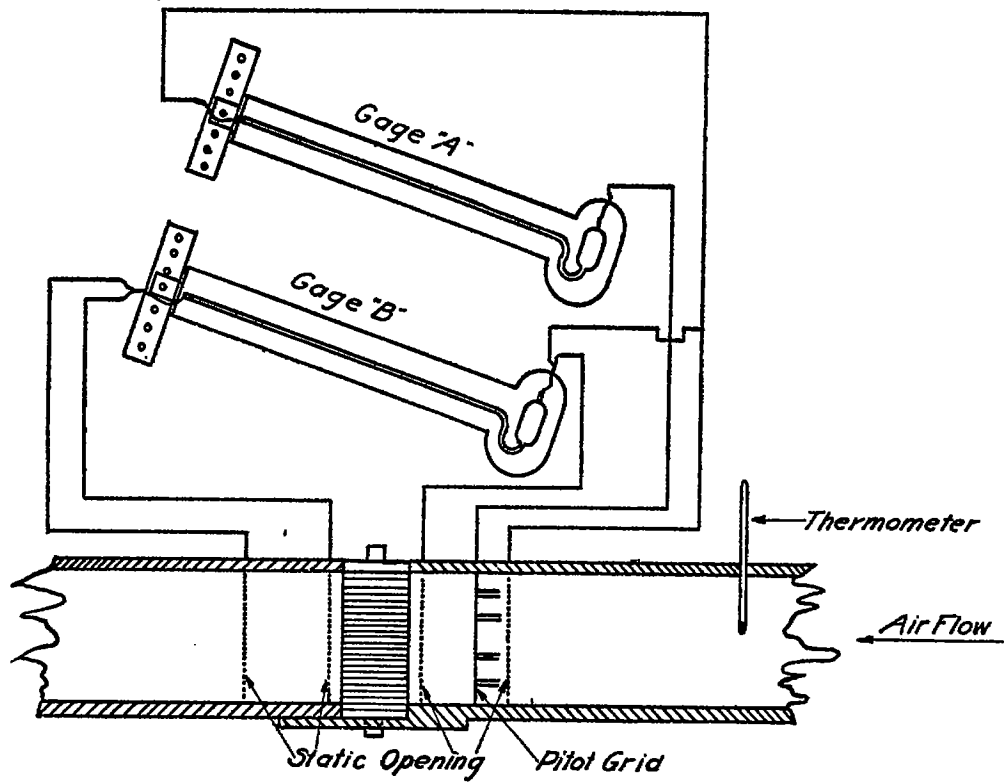

Figure 11

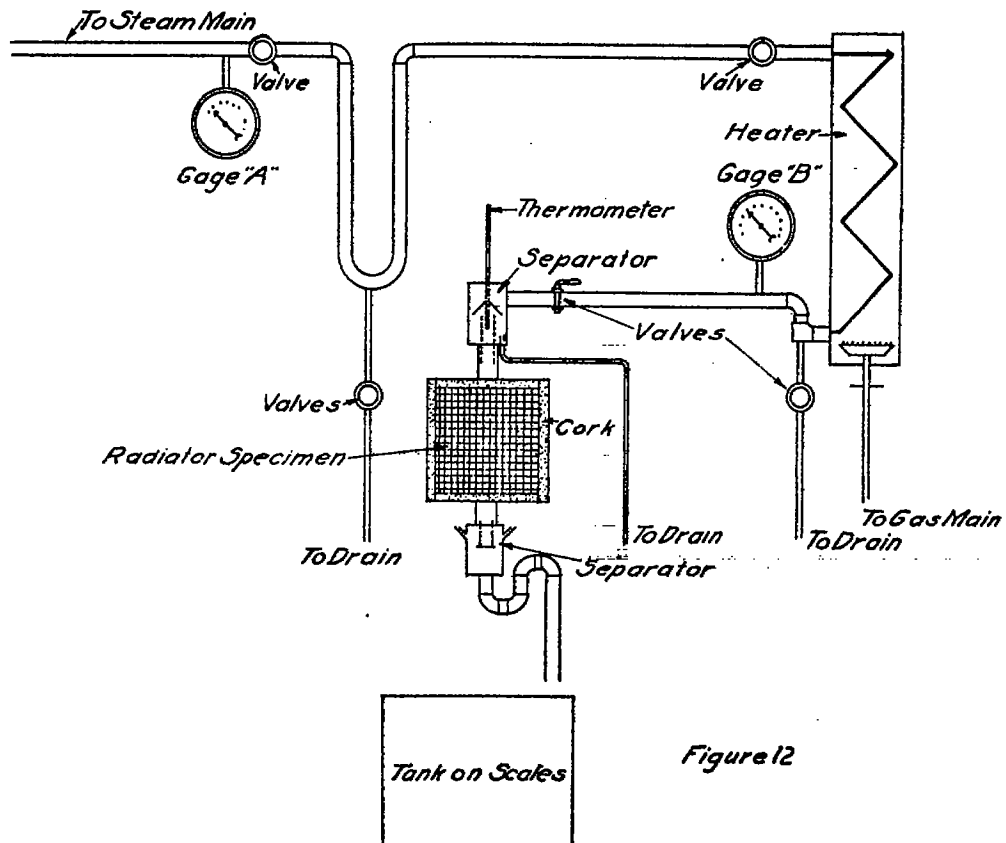
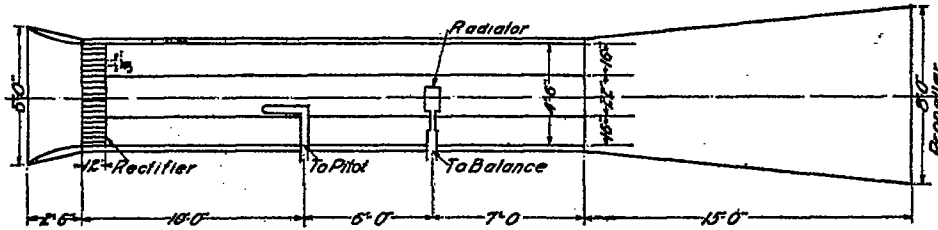
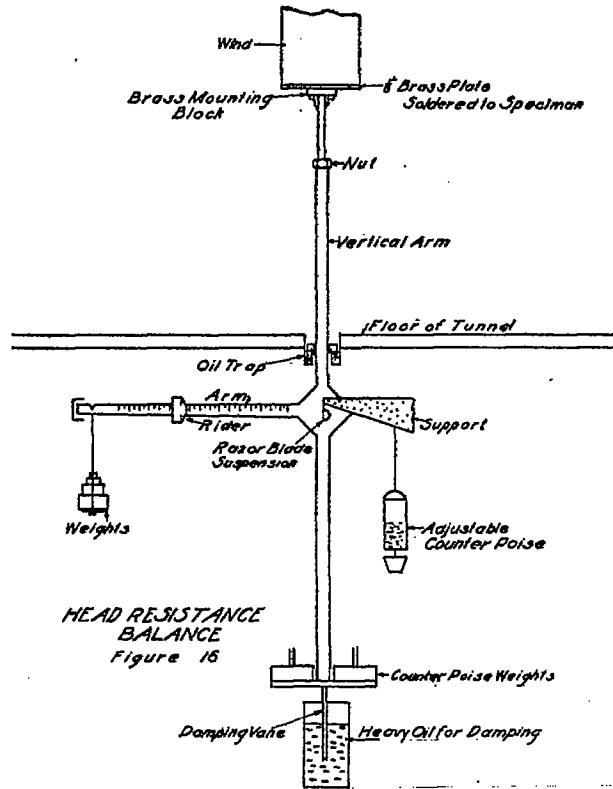

Figure 12



NOTE Figures show approx dimensions only

LARGE WIND TUNNEL
 Figure 15



HEAD RESISTANCE
 BALANCE
 Figure 16

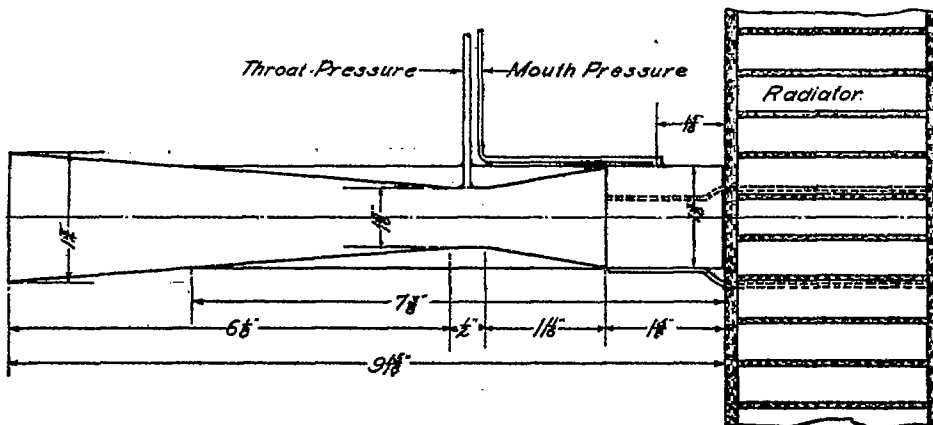

SPECIAL AIR VENTURI
 FOR
 AIR FLOW THROUGH RADIATOR
 Figure-17

Heat given up by the steam.—Let—

- T_b = condensation temperature of the steam in ° C.
- S = superheat in ° C.
- L = latent heat in B. T. U. / pound.
- C_p = specific heat of the steam.
- H = heat lost by 1 pound of steam in B. T. U.
- T = mean temperature of the radiator contents.

If the arithmetic mean temperature of the superheated steam and the condensation temperature are weighted according to the amount of heat lost at each temperature,

$$(17) \quad HT = \left(T_b + \frac{S}{2} \right) C_p S + L T_b$$

and

$$(18) \quad T = T_b + \left(\frac{C_p}{2H} \right) S^2 \text{ Since } H = L + C_p S$$

The second term of (18) is small and is a function of the superheat only (assuming C_p to be sensibly constant) so a table of values for it was prepared from steam table data.

H is likewise a function of the superheat only and was tabulated in the same way (Goodenough's Steam and Ammonia Tables 1915).

If t_c = number of seconds required to condense w pounds of steam

and Q = heat lost in H. P. / ft.²/100° F.

and $A = 176.7 w$, 176.7 being a conversion factor, then by definition of Q

$$(19) \quad Q = \frac{A H}{t_c (T - t)}$$

A computation sheet, (fig. 14) is reproduced.

(3) POWER EXPENDED IN CARRYING THE RADIATOR.

The measurements needed to determine this quantity were made in a tunnel whose cross section was large compared with the dimensions of the radiator tested, in contradistinction to the heat measurements, which were all made in bulkhead tunnels. Figure 15 shows a sketch of this large tunnel.

It was of octagonal section, 54 inches in inside diameter. The entering air passed through a honeycomb of sheet metal cells, 3 inches in diameter and 12 inches deep, through a straight section of 25 feet long, and out through a conical diffuser. A four-blade propeller fan driven by a 75-horsepower direct-current motor drew air through the tunnel. A continuous speed range from 15 to 90 miles per hour could be obtained by adjustments provided by rheostats in both field and armature and two voltages, 110 and 240. A Pitot tube read on an inclined water gauge measured the air speed to 1 per cent.

The head resistance was measured directly on a balance, figure 16. This was mounted a little below the floor of the tunnel, and consisted essentially of a bell crank suspended by thin flexible steel strips, with a horizontal arm on which weights could be hung below the tunnel, and a vertical arm passing up through the tunnel floor to support the specimen. A second vertical arm extended below the fulcrum and carried counterpoises for lowering the center of gravity, and a second short horizontal arm with adjustable counterpoises provided a zero adjustment. The joint at the tunnel floor was rendered air-tight by an oil trap. The vertical arm that supported the specimen was extensible, and was fitted at the top with a detachable brass block. This was screwed to a plate $\frac{1}{4}$ inch or less in thickness, soldered to the lower side of the specimen under test.

CALIBRATION OF APPARATUS.

The tunnel cross section was explored with a movable Pitot and found to be uniform within 1 per cent at all points more than 8 inches from the wall. Silk threads strung from a fine vertical wire showed that there were considerable disturbances in the air stream in the neighborhood of the specimen, but no appreciable ones within 8 inches of the tunnel wall. This was taken to indicate that the tunnel was large enough to give free air conditions.

The balance was calibrated by applying known horizontal forces to the vertical arm and observing the balancing forces on the horizontal arm. This gave the correct factor by which to multiply the balance reading, for different lengths of the vertical arm, to obtain the true force. Ordinarily a length was chosen which made this factor unity, so that the force was read directly.

Method of observing.—The radiator specimen (without water boxes) was mounted on the vertical arm and the distance from its center to the fulcrum adjusted to the desired value. To find the position of no yaw, a specimen was set at various angles, the position of minimum head resistance assumed to represent zero yaw, and a reference point marked on the tunnel wall by sighting across the front of the radiator. The same result could be obtained by sighting through the radiator tubes at the honeycomb at the tunnel entrance. In other cases, the angle of yaw was measured roughly by sighting across the front of the section at a scale mounted on the tunnel wall. Because of fluctuations in the air speed, two observers took simultaneous readings on the balance and Pitots, since there was no sensible lag between the two instruments. Nine points were usually observed.

Method of computing.—The apparent head resistance was obtained by multiplying the readings by the proper factor. By subtracting from this the force on the supporting arm (determined by a previous calibration) the force on the specimen was found. This divided by the frontal area gave the head resistance, in lb. wt. / ft.². Assuming a lift-drift ratio of 5.4, the horsepower used was,

$$\frac{1}{375} \left(R + \frac{W}{5.4} \right) V$$

Wherein

R = resistance in lb. wt./ft.².

W = core weight in lb./ft.² front.

V = air speed in mis./hr.

$\frac{1}{375}$ = a conversion factor.

The speed was computed from the ordinary Pitot formula:

$$(20) \quad V = K \sqrt{\frac{h}{d}}$$

Wherein

K = a conversion factor.

h = gauge reading.

d = air density in lb./ft.³

At first the temperature, pressure, and humidity of the air were observed, and the actual air density and speed computed. The experiments, however, soon showed that the usual formula for the resistance of an airplane, i. e.,

$$(21) \quad R = BdV^2 \quad (B = \text{a constant})$$

also applied to these tests.

Accordingly a value of d in the neighborhood of the observed values was selected and used in (20) to compute V . Thus, neither the actual speed nor density were used, but such a value of V as gave, when combined with d , (the standard density) the observed head resistance; for

Let d_a = actual density and substitute for V in (21) its value given by (20). This gives

$$(22) \quad R = \frac{Bk^2hd_a}{d_a} = \frac{Bk^2hd_s}{d_s}$$

It is easily shown by dimensional considerations that if the exponent of the velocity is different from 2, say n , then the velocity required with d_s to give R will be

$$\left(\frac{d_s}{d_a}\right)^{\frac{2-n}{2n}} V_s \text{ instead of } V_s \left(V_s = K\sqrt{\frac{h}{d_s}}\right)$$

If, then, n were as low as 1.8 and $d_s/d_a = 1.056$ (the greatest difference from unity that occurred) this factor would be 1.003, a negligible difference from unity. d_s was taken as 0.0750 lbs./ft. corresponding to 65° F., 29.17 in Hg, 40 per cent humidity.

(4) MASS FLOW OF AIR THROUGH THE CORE.

PRELIMINARY ATTEMPTS.

Three different methods were tried for measuring the mass flow of air through the core before a satisfactory one was found.

(1) A careful and persistent attempt was made to measure the flow with a small Pitot tube behind the core, and in positions ranging from well within the cell to a few inches behind the core, but it appeared to be out of the question to use a Pitot tube in the turbulent air encountered.

(2) Threads were attached to the rear edges of the radiator to define the stream, in the hope that the air passing through the core could be followed to a position where the flow would not be too turbulent for the use of a Pitot tube, and that in such a position it would be possible to measure the velocity, and the area of cross section of the air that had passed through the core. But it was found that, even aside from the difficulty introduced by the tendency of the pull on the threads to straighten them, so that they would not truly follow the streamline, the flapping of the threads was too great, and consequently their position too indefinite to allow of measurement of the area included between them.

(3) A hot-wire anemometer was tried, and gave promise of very fair results, but before it had been thoroughly tried out, a simpler method was discovered and the use of the instrument was discontinued.

APPARATUS USED.

The method finally adopted employed a specially constructed Venturi, a longitudinal section of which is shown in figure 17. The cylindrical throat and the two cones were made up from sheet copper soldered together, and the joints filed down into curves of stream-line form. A copper tube led out from a single small needle hole in the side of the throat. A piece of sheet iron bent into cylindrical form was soldered over the cones extending from 1½ inches before the front cone nearly to the rear end and covering the central contracted portion, which would else cause considerable resistance to the air stream. A second needle hole before the front cone was connected to a small tube which ran back along the outer surface, and turned up where it reached the tube coming from the throat. An inclined water gauge measured the pressure difference. Three wires soldered to the sides of the Venturi passed through the cells of the radiator, and were bent over in front so as to fasten the Venturi firmly in place behind the radiator.

CALIBRATION OF THE VENTURI.

Tests in the inclosed tunnel with eight different sections of widely differing types of core gave nearly the same pressure difference for same air flow through the tunnel and this was very close to that given when no radiator at all was used. For ordinary types of core this was true within about 3 per cent and with cores in which the air flow was very much obstructed within 6 per cent. No high degree of accuracy is claimed for this, but it was very convenient and sufficient for the purpose.

A calibration curve was obtained by running the Venturi in the open in the large wind tunnel against the Pitot tube of the tunnel. The square root of the Venturi pressure difference (in gms./cm²) was plotted against the mass flow as computed from the tunnel Pitot. This is the product of the air speed in feet sec. by d_s (.0750 lb./ft.³). The resulting curve was very flat, almost linear. Six calibrations at different times during a period of six months gave identical curves.

NOTE.—This calibration was in terms of mass flow in pounds per second per square foot of Venturi mouth, and hence mass flow through radiators is per square foot frontal-core area, and not of air-tube area.

Method of observing.—The specimen under observation was mounted in the 54-inch wind tunnel in the same manner as for head resistance measurements, the Venturi was attached to the rear face, its pressure tubes connected to an inclined water gauge by means of tubes passing through a hole in the tunnel floor, and simultaneous readings taken of its pressure difference and the air speed in the tunnel. These readings were taken at from 9 to 15 different speeds for each radiator.

Method of computing.—The Venturi gauge reading was multiplied by the gauge factor to obtain grams per cm². The square root of this was computed and used as argument to determine the mass flow from the calibration curve. The mass flow was then plotted against V_s for each radiator.

As in the case of the head resistance, the actual air density was not needed. The reason for this is slightly different however. The Venturi really measures velocity, just as the Pitot, so that relation between its readings and those of the Pitot tubes furnish a measure of the ratio of the amount of air going through the radiator to the amount that would pass through that section if the radiator were absent. It seems permissible to assume that this ratio is independent of the air density, because the viscosity is known to be independent of the density, and its effect in this case is not large anyway.