

THE REQUIREMENTS FOR ACQUIRING THE PRODUCT(S) DESCRIBED HEREIN SHALL CONSIST OF THIS SPECIFICATION SHEET AND THE ISSUE OF THE FOLLOWING SPECIFICATION LISTED IN THAT ISSUE OF THE DOORS SPECIFIED IN THE SOLICITATION NONE

THIS SPECIFICATION IS APPROVED FOR USE BY ALL DEPARTMENTS AND AGENCIES OF THE DEPARTMENT OF DEFENSE

Form Approved
 OMB No 0704-0188

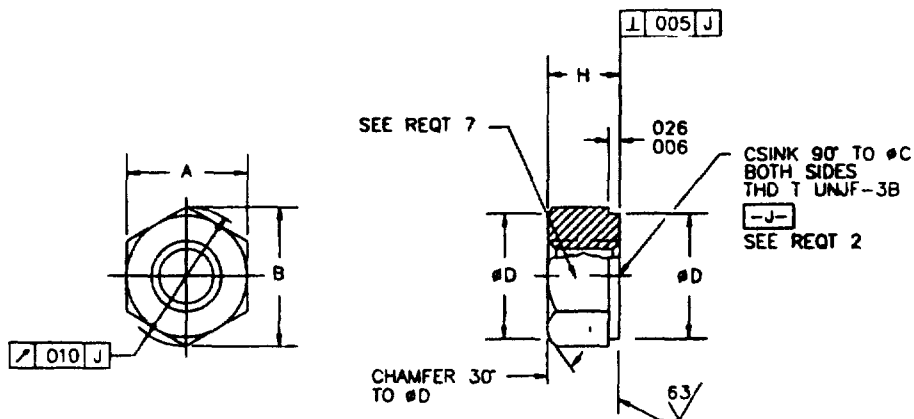

TABLE I DASH NUMBERS AND DIMENSIONS.

DASH NO	THREAD T	A	B MIN	#C	#D	H	APPROX MASS LB/100
-04	112-48	243 - 251	277	112 - 132	240 - 280	126 - 146	18
-06	138-40	305 - 313	347	138 - 158	302 - 322	128 - 146	28
-08	164-36	336 - 345	383	164 - 184	334 - 354	128 - 146	33
-09	190-32	367 - 376	419	190 - 210	365 - 385	146 - 166	43
-10	250-28	430 - 439	491	250 - 270	428 - 448	209 - 229	77
-11	3125-24	492 - 502	561	312 - 332	490 - 510	256 - 276	113
-12	375-24	553 - 564	631	375 - 395	552 - 572	318 - 338	168
-13	4375-20	679 - 690	775	438 - 458	678 - 698	365 - 385	287
-14	500-20	741 - 752	846	500 - 520	740 - 760	428 - 448	397
-15	5625-18	865 - 877	987	562 - 582	865 - 885	474 - 494	619
-16	625-18	928 - 940	1059	625 - 645	928 - 948	537 - 557	770
-17	750-16	1052 - 1064	1200	750 - 770	1052 - 1072	646 - 666	1095
-18	875-14	1239 - 1252	1414	875 - 895	1240 - 1260	756 - 776	1793
-19	1000-12	1427 - 1440	1628	1000 - 1020	1428 - 1448	865 - 885	2740

F DENOTES CHANGE(S)

INCH-POUND

PREPARING ACTIVITY DLA-1S
 CUSTODIANS ARMY- AV NAVY- AS
 AIR FORCE- 99 DLA-

MILITARY SPECIFICATION SHEET
 TITLE
 NUT, PLAIN, HEXAGON-A-286

SPECIFICATION SHEET NUMBER
MS9356 30 SEP 1994
 REV F

SUPERSEDING
 MS9356 E 30 SEP 86 (SEE NOTE 8)

AMSC- N/A FSC 5310

DISTRIBUTION STATEMENT

A Approved for public release distribution is unlimited

Page 1 of 2

DD Form 672, MAY 88

PREVIOUS EDITIONS ARE OBSOLETE

Form Approved
 OMB No 0704-0188

REQUIREMENTS

- (F) 1 **MATERIAL** CORROSION AND HEAT RESISTANT STEEL IN ACCORDANCE WITH AMS 5732 OR AMS 5737
- 2 **THREADS** THREADS IN ACCORDANCE WITH MIL-S-8879
- 3 **CLEANING** FINISHED PARTS SHALL BE DEGREASED AND IMPRESSED FOR NOT LESS THAN 20 MINUTES IN A SOLUTION OF 1 VOLUME OF NITRIC ACID (SP GR 142) AND 9 VOLUMES OF WATER AT ROOM TEMPERATURE
- (F) 4 **SURFACE TEXTURE** SURFACE TEXTURE, UNLESS OTHERWISE SPECIFIED SHALL BE 125 MICROMETRES EXCEPT FOR HEX FACES IN ACCORDANCE WITH ANSI/ASME B46.1
- 5 **FLUORESCENT PENETRANT INSPECTION** FLUORESCENT PENETRANT INSPECTION SHALL BE IN ACCORDANCE WITH AMS 2645 AND AS 3071
- 6 **DIMENSIONING AND TOLERANCING** DIMENSIONING AND TOLERANCING SHALL BE IN ACCORDANCE WITH ANSI Y14.5M
- 7 **MARKING** MARK PART NUMBER AND MANUFACTURER'S IDENTIFICATION IN ACCORDANCE WITH AS 478 CLASS C MULTIPLE MARKING OF BAR STOCK IS PERMISSIBLE PROVIDED POSITIVE IDENTIFICATION IS SHOWN PARTS SHALL BE MARKED BEFORE THREADING DASH NUMBERS MAY APPEAR ON ADJACENT FLATS
- 8 **EDGES** BREAK SHARP EDGES 003-015 UNLESS OTHERWISE SPECIFIED
- 9 **TOLERANCES** UNLESS OTHERWISE SPECIFIED TOLERANCES FOR ANGULAR DIMENSIONS ± 5 LINEAR DIMENSIONS ± 0.10
- 10 **PART NUMBER** THE PART NUMBER SHALL CONSIST OF THE BASIC MS NUMBER FOLLOWED BY A DASH NUMBER FROM TABLE I

EXAMPLE MS9356-04
 └───┬─── DASH NUMBER
 └───┴─── BASIC MS NUMBER
 MS9356-04 INDICATES - NUT PLAIN HEXAGON A-286, 112-48 UNJF-3B

NOTES

- 1 ALL DIMENSIONS ARE IN INCHES
- 2 DO NOT USE UNASSIGNED PART NUMBERS.
- (F) 3 IN THE EVENT OF A CONFLICT BETWEEN THE TEXT OF THIS STANDARD AND THE REFERENCES CITED HEREIN THE TEXT OF THIS STANDARD SHALL TAKE PRECEDENCE
- (F) 4 UNLESS OTHERWISE SPECIFIED ISSUES OF REFERENCED DOCUMENTS ARE THOSE IN EFFECT AT THE TIME OF SOLICITATION
- (F) 5 THIS DOCUMENT WAS DEVELOPED COOPERATIVELY WITH THE SAE AEROSPACE PROPULSION DIVISION
- 6 AS AND AMS ARE SAE PUBLICATIONS
- (C) 7 CERTAIN PROVISIONS (LIMITS OF SIZE ACROSS-FLATS DIMENSIONS) OF THIS DOCUMENT ARE THE SUBJECT OF INTERNATIONAL STANDARDIZATION AGREEMENT ASCC AID STD 17/2 WHEN REVISION OR CANCELLATION OF THIS STANDARD IS PROPOSED THE DEPARTMENTAL CUSTODIAN WILL INFORM THEIR RESPECTIVE DEPARTMENTAL STANDARDIZATION OFFICE SO THAT APPROPRIATE ACTION MAY BE TAKEN RESPECTING THE INTERNATIONAL AGREEMENT CONCERNED
- (F) 8 MS9356 SUPERSEDES AN 121528 THRU AN 121550

THE REQUIREMENTS FOR ACQUIRING THE PRODUCT(S) DESCRIBED HEREIN SHALL CONSIST OF THIS SPECIFICATION SHEET AND THE ISSUE OF THE FOLLOWING SPECIFICATION LISTED IN THAT ISSUE OF THE DOBSS SPECIFIED IN THE SOLICITATION NONE

THIS SPECIFICATION IS APPROVED FOR USE BY ALL DEPARTMENTS AND AGENCIES OF THE DEPARTMENT OF DEFENSE

PREPARING ACTIVITY DLA-IS CUSTODIANS ARMY- AV NAVY- AS AIR FORCE- 99 DLA- REVIEW B2 USER PROJECT NUMBER 5310-2004	MILITARY SPECIFICATION SHEET TITLE NUT, PLAIN, HEXAGON-A-286	SPECIFICATION SHEET NUMBER MS9356 30 SEP 1994 REV F SUPERSEDING MS9356 E 30 SEP 86 (SEE NOTE B) AMSC- N/A FSC 5310
DISTRIBUTION STATEMENT A Approved for public release distribution is unlimited		Page 2 of 2

DD Form 672, MAY 88

PREVIOUS EDITIONS ARE OBSOLETE