

FED. SUP CLASS
 4730

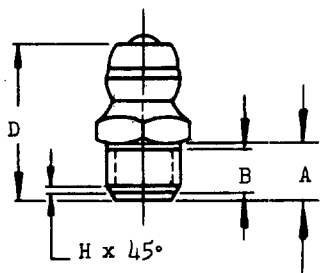
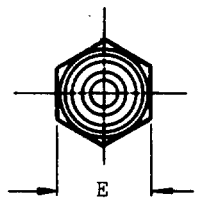

FIGURE 1

BODY CONTOURS
 OPTIONAL WITH
 MANUFACTURERS

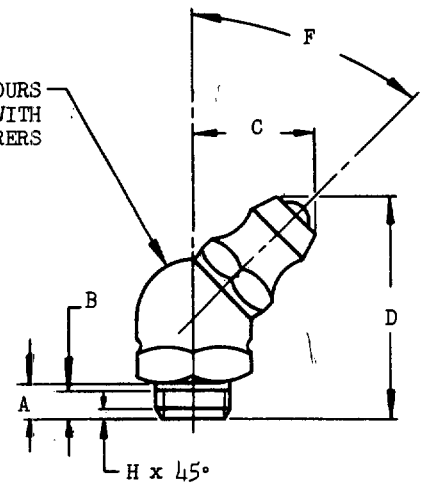

FIGURE 2

NOTICE—When Government drawings, specifications, or other data are used for any purpose other than in connection with a definitely related Government procurement operation, the United States Government thereby incurs no responsibility, nor any obligation whatsoever; and the fact that the Government may have formulated, furnished, or in any way supplied the said drawings, specifications, or other data is not to be regarded by implication or otherwise as in any manner licensing the holder or any other person or corporation, or conveying any rights or permission to manufacture, use, or sell any patented invention that may in any way be related thereto.

MS PART NO.	FIIN	FIG	(a) THREAD T	A		C MAX	D MAX	A		H
				A +.031	(b) B			E +.003	F	
MS15002-1		1	1/4-28 UNF-2A	.125	.075	--	.531	.281	--	.036
MS15002-2 (c)			5/16-32 NEF-2A				.562	.312		.031
MS15002-3		2	1/4-28 UNF-2A			.438	.750	.375	45°	.036
MS15002-4 (c)			5/16-32 NEF-2A			.500			65°	.031

(a) THREADS TO BE IN ACCORDANCE WITH HANDBOOK H-28.

(b) MINIMUM EFFECTIVE THREAD.

(c) PART NUMBERS MS15002-2 AND -4 INACTIVE FOR DESIGN AFTER 27 March 1959.

MATERIAL: STEEL, SEE PROCUREMENT SPECIFICATION

(A) FINISH: CADMIUM PLATE, OR ZINC PLATE, SEE PROCUREMENT SPECIFICATION.

(A) DIMENSIONS IN INCHES. UNLESS OTHERWISE SPECIFIED, TOLERANCES: ANGLES +5°. TIP DESIGN OPTIONAL IN ACCORDANCE WITH MS15000. THIS STANDARD TAKES PRECEDENCE OVER DOCUMENTS REFERENCED HEREIN.

REFERENCED DOCUMENTS SHALL BE OF THE ISSUE IN EFFECT ON DATE OF INVITATIONS FOR BID.

PROVISIONS OF THIS STANDARD ARE THE SUBJECT OF INTERNATIONAL STANDARDIZATION AGREEMENTS. WHEN REVISION OR CANCELLATION OF THIS STANDARD IS PROPOSED, THE DEPARTMENTAL CUSTODIANS WILL INFORM THEIR RESPECTIVE DEPARTMENTAL STANDARDIZATION OFFICE SO THAT APPROPRIATE ACTION MAY BE TAKEN RESPECTING THE INTERNATIONAL AGREEMENT CONCERNED.

This military standard is approved by the Department of Defense and is mandatory on all activities. Selection for all new engineering and design applications and for repetitive use shall be made from this document.

P.A. Navy-BuAer Other Cust Army-Ord USAF	Other Interest Inter- national	TITLE FITTINGS, LUBRICATION (HYDRAULIC) SURFACE CHECK, STRAIGHT THREADS, STEEL, TYPE II	MILITARY STANDARD MS15002
Procurement Specification MIL-F-3541	SUPERSEDES:	SHEET 1 OF 1	

APPROVED 12 Jul 51 REVISED 27 Mar 59