

NOTE: MIL-STD-413 has been redesignated as a Test Method Standard. The cover page has been changed for Administrative reasons. There are no other changes to this Document.

MIL-STD-413C  
8 DECEMBER 1980  
SUPERSEDING  
MIL-STD-413B  
28 FEBRUARY 1969

DEPARTMENT OF DEFENSE  
TEST METHOD  
  
VISUAL INSPECTION GUIDE  
FOR  
RUBBER ELASTOMERIC O-RINGS



AMSC N/A

FSC 5330

DISTRIBUTION STATEMENT A. Approved for public release; distribution is unlimited.

MIL-STD-413C  
8 December 1980

DEPARTMENT OF DEFENSE  
WASHINGTON, DC 20360

Visual Inspection Guide for  
Rubber O-Rings

MIL-STD-413C

1. This Military Standard is mandatory for use by all Departments and Agencies of the Department of Defense.

2. Beneficial comments (recommendations, additions, deletions) and any pertinent data which may be of use in improving this document should be addressed to: Commander, Naval Sea Systems Command, SEA 3112, Department of the Navy, Washington, DC 20362 by using the self-addressed Standardization Document Improvement proposal (DD Form 1426) appearing at the end of this document or by letter.

MIL-STD-413C  
8 December 1980

#### FOREWORD

Government material acquisition specifications have been primarily concerned with detailing composition, construction, and necessary physical requirements. However, little attention has been paid to defining the limits of acceptable quality regarding manufacturing imperfections other than such generalizations as "the workmanship shall be first class." In such a diverse industry as that of rubber manufacturing, individual plants vary considerably in their production and quality control techniques. Imperfections are likely to occur from many causes, such as variation in the quality of the basic materials and variations in manufacturing processes and finishing operations. Therefore, the quality generalizations used in this standard must, of necessity, cover a considerable range which represents the best available judgement. This standard is issued as a practical yardstick which quality assurance personnel will use to appraise the acceptability of O-rings concerning visible imperfections.

CONTENTS

|              |   | Page  |
|--------------|---|-------|
| Paragraph 1. | SCOPE . . . . .                           | 1     |
| 1.1          | Purpose . . . . .                         | 1     |
| 1.2          | Scope . . . . .                           | 1     |
| 2.           | REFERENCED DOCUMENTS . . . . .            | 1     |
| 2.1          | Issues of documents . . . . .             | 1     |
| 3.           | DEFINITIONS . . . . .                     | 1     |
| 4.           | GENERAL REQUIREMENTS . . . . .            | 3     |
| 4.1          | Examination conditions . . . . .          | 3     |
| 4.2          | Identification of imperfections . . . . . | 3     |
| 4.3          | Evaluation of imperfections . . . . .     | 3     |
| 5.           | DETAILED REQUIREMENTS . . . . .           | 4     |
| 5.1          | Nondestructive tests . . . . .            | 4     |
| 5.2          | Rejection of individual O-rings . . . . . | 4     |
| 5.3          | Sampling . . . . .                        | 4 & 5 |

FIGURES

|        |  |    |
|--------|--|----|
| Figure | 1. Backrind, unacceptable, W = 0.070" (1.78 mm) . . . . .                  | 9  |
|        | 2. Backrind, unacceptable, W = 0.103" (2.62 mm) . . . . .                  | 10 |
|        | 3. Backrind, unacceptable, W = 0.103" (2.62 mm) . . . . .                  | 11 |
|        | 4. Backrind, unacceptable, W = 0.103" (2.62 mm) . . . . .                  | 12 |
|        | 5. Backrind, acceptable, W = 0.103" (2.62 mm) . . . . .                    | 13 |
|        | 6. Backrind, acceptable, W = 0.103" (2.62 mm) . . . . .                    | 14 |
|        | 7. Backrind, unacceptable, W = 0.139" (3.53 mm) . . . . .                  | 15 |
|        | 8. Backrind, acceptable, W = 0.139" (3.53 mm) . . . . .                    | 16 |
|        | 9. Backrind, acceptable, W = 0.210" (5.33 mm) . . . . .                    | 17 |
|        | 10. Backrind, unacceptable, W = 0.210" (5.33 mm) . . . . .                 | 18 |
|        | 11. Parting line indentation, acceptable, W = 0.070" (1.78 mm) . . . . .   | 19 |
|        | 12. Parting line indentation, acceptable, W = 0.070" (1.78 mm) . . . . .   | 20 |
|        | 13. Parting line indentation, acceptable, W = 0.070" (1.78 mm) . . . . .   | 21 |
|        | 14. Parting line indentation, unacceptable, w = 0.070" (1.78 mm) . . . . . | 22 |
|        | 15. Parting line indentation, acceptable, W = 0.103" (2.62 mm) . . . . .   | 23 |
|        | 16. Parting line indentation, acceptable, W = 0.103" (2.62 mm) . . . . .   | 24 |
|        | 17. Parting line indentation, acceptable, W = 0.103" (2.62 mm) . . . . .   | 25 |
|        | 18. Parting line indentation, unacceptable, W = 0.103" (2.62 mm) . . . . . | 26 |
|        | 19. Parting line indentation, unacceptable, w = 0.139" (3.53 mm) . . . . . | 27 |

CONTENTS (Continued)

| Figure |  | Page |
|--------|--|------|
| 20.    | Parting line indentation, unacceptable,<br>w = 0.139" (3.531 mm) . . . . . | 28   |
| 21.    | Parting line indentation, acceptable, W = 0.139"<br>(3.53 mm) . . . . .    | 29   |
| 22.    | Parting line indentation, unacceptable,<br>w = 0.139" (3.53 mm) . . . . .  | 30   |
| 23.    | Parting line indentation, acceptable, W = 0.210"<br>(5.33 mm) . . . . .    | 31   |
| 24.    | Parting line indentation, unacceptable,<br>w = 0.210" (5.33 mm) . . . . .  | 32   |
| 25.    | Foreign material, acceptable, W = 0.103"<br>(2.62 mm) . . . . .            | 33   |
| 26.    | Foreign material, unacceptable, W = 0.103"<br>(2.62 mm) . . . . .          | 34   |
| 27.    | Foreign material, acceptable, W = 0.103"<br>(2.62 mm) . . . . .            | 35   |
| 28.    | Foreign material, unacceptable, W = 0.103"<br>(2.62 mm) . . . . .          | 36   |
| 29.    | Foreign material, acceptable, W = 0.139"<br>(3.53 mm) . . . . .            | 37   |
| 30.    | Foreign material, unacceptable, W = 0.139"<br>(3.53 mm) . . . . .          | 38   |
| 31.    | Foreign material, acceptable, W = 0.139"<br>(3.53 mm) . . . . .            | 39   |
| 32.    | Foreign material, unacceptable, W = 0.210"<br>(5.33 mm) . . . . .          | 40   |
| 33.    | Foreign material, unacceptable, W = 0.275"<br>(6.98 mm) . . . . .          | 41   |
| 34.    | Excessive trimming, acceptable, W = 0.103"<br>(2.62 mm) . . . . .          | 42   |
| 35.    | Excessive trimming, unacceptable, W = 0.103"<br>(2.62 mm) . . . . .        | 43   |
| 36.    | Excessive trimming, acceptable, W = 0.103"<br>(2.62 mm) . . . . .          | 44   |
| 37.    | Excessive trimming, unacceptable, W = 0.103"<br>(2.62 mm) . . . . .        | 45   |
| 38.    | Excessive trimming, acceptable, W = 0.139"<br>(3.53 mm) . . . . .          | 46   |
| 39.    | Excessive trimming, unacceptable, W = 0.139"<br>(3.53 mm) . . . . .        | 47   |
| 40.    | Excessive trimming, acceptable, W = 0.210"<br>(5.33 mm) . . . . .          | 48   |
| 41.    | Excessive trimming, unacceptable, W = 0.275"<br>(6.98 mm) . . . . .        | 49   |
| 42.    | Excessive flash, unacceptable, W = 0.103"<br>(2.62 mm) . . . . .           | 50   |
| 43.    | Excessive flash, unacceptable, W = 0.103"<br>(2.62 mm) . . . . .           | 51   |

CONTENTS (Continued)

| Figure |  | Page |
|--------|--|------|
| 44.    | Excessive flash, unacceptable, W = 0.103"<br>(2.62 mm) . . . . .           | 52   |
| 45.    | Excessive flash, acceptable, W = 0.103"<br>(2.62 mm) . . . . .             | 53   |
| 46.    | Excessive flash, acceptable, W = 0.139"<br>(3.53 mm) . . . . .             | 54   |
| 47.    | Excessive flash, unacceptable, W = 0.139"<br>(3.53 mm) . . . . .           | 55   |
| 48.    | Excessive flash, acceptable, W = 0.139"<br>(3.53 mm) . . . . .             | 56   |
| 49.    | Excessive flash, unacceptable, W = 0.139"<br>(3.53 mm) . . . . .           | 57   |
| 500    | Excessive flash, acceptable, W = 0.210"<br>(5.33 mm) . . . . .             | 58   |
| 51.    | Excessive flash, unacceptable, W = 0.275"<br>(6.98 mm) . . . . .           | 59   |
| 52.    | Non-fill, unacceptable, W = 0.070" (1.78 mm) . . . . .                     | 60   |
| 53.    | Non-fill, unacceptable, W = 0.103" (2.62 mm) . . . . .                     | 61   |
| 54.    | Non-fill, acceptable, W = 0.139" (3.53 mm) . . . . .                       | 62   |
| 55.    | Non-fill, unacceptable, W = 0.139" (3.53 mm) . . . . .                     | 63   |
| 56.    | Non-fill, unacceptable, W = 0.139" (3.53 mm) . . . . .                     | 64   |
| 57.    | Non-fill, unacceptable, W = 0.210" (5.33 mm) . . . . .                     | 65   |
| 58.    | Non-fill, unacceptable, W = 0.210" (5.33 mm) . . . . .                     | 66   |
| 59.    | Non-fill, acceptable, W = 0.275" (6.98 mm) . . . . .                       | 67   |
| 60.    | Non-fill, unacceptable, W = 0.275" (6.98 mm) . . . . .                     | 68   |
| 61.    | Mold deposit indentations, unacceptable,<br>W = 0.070" (1.78 mm) . . . . . | 69   |
| 62.    | Mold deposit indentations, acceptable,<br>W = 0.103" (2.62 mm) . . . . .   | 70   |
| 63.    | Mold deposit indentations, acceptable,<br>W = 0.139" (3.53 mm) . . . . .   | 71   |
| 64.    | Mold deposit indentations, unacceptable,<br>W = 0.139" (3.53 mm) . . . . . | 72   |
| 65.    | Mold deposit indentations, unacceptable,<br>W = 0.139" (3.53 mm) . . . . . | 73   |
| 66.    | Mold deposit indentations, unacceptable,<br>W = 0.139" (3.53 mm) . . . . . | 74   |
| 67.    | Mold deposit indentations, acceptable,<br>W = 0.139" (3.53 mm) . . . . .   | 75   |
| 68.    | Mold deposit indentations, acceptable,<br>W = 0.210" (5.33 mm) . . . . .   | 76   |
| 69.    | Mold deposit indentations, unacceptable,<br>W = 0.275" (6.98 mm) . . . . . | 77   |
| 70.    | Flow marks, unacceptable, W = 0.070" (1.78 mm) . . . . .                   | 78   |
| 71.    | Flow marks, unacceptable, W = 0.139" (3.53 mm) . . . . .                   | 79   |
| 72.    | Flow marks, acceptable, W = 0.139" (3.53 mm) . . . . .                     | 80   |
| 73.    | Flow marks, unacceptable, W = 0.139" (3.53 mm) . . . . .                   | 81   |
| 74.    | Flow marks, acceptable, W = 0.139" (3.53 mm) . . . . .                     | 82   |
| 75.    | Flow marks, unacceptable, W = 0.139" (3.53 mm) . . . . .                   | 83   |
| 76.    | Flow marks, unacceptable, W = 0.139" (3.53 mm) . . . . .                   | 84   |

CONTENTS (Continued)

|        |   | Page |
|--------|---|------|
| Figure | 77. Flow marks, acceptable, W = 0.139" (3.53 mm) . . .                            | 85   |
|        | 78. Flow marks, acceptable, W = 0.210" (5.33 mm) . . .                            | 86   |
|        | 79. Off-register and/or mismatch, unacceptable,<br>w = 0.070" (1.78 mm) . . . . . | 87   |
|        | 80. Off-register and/or mismatch, unacceptable,<br>w = 0.103" (2.62 mm) . . . . . | 88   |
|        | 81. Off-register and/or mismatch, unacceptable,<br>w = 0.139" (3.53 mm) . . . . . | 89   |
|        | 82. Off-register and/or mismatch, acceptable,<br>w = 0.139" (3.53 mm) . . . . .   | 90   |
|        | 83. Off-register and/or mismatch, acceptable,<br>w = 0.139" (3.53 mm) . . . . .   | 91   |
|        | 84. Off-register and/or mismatch, acceptable,<br>w = 0.139" (3.53 mm) . . . . .   | 92   |
|        | 85. Off-register and/or mismatch, acceptable,<br>w = 0.210" (5.33 mm) . . . . .   | 93   |
|        | 86. Off-register and/or mismatch, unacceptable,<br>w = 0.210" (5.33 mm) . . . . . | 94   |
|        | 87. Supplementary illustrations of surface<br>imperfections . . . . .             | 95   |

TABLES

|       |   |   |
|-------|---|---|
| Table | I. Index to photographs of representative acceptable and unacceptable surface imperfections . . .     | 6 |
|       | II. Quantitative classification of imperfections, maximum acceptable dimensions in inches . . . .     | 7 |
|       | III. Quantitative classification of imperfections, maximum acceptable dimensions in millimeters . . . | 8 |



MIL-STD-413C  
8 December 1980

## 1. SCOPE

1.1 Purpose. The objective of this standard is to assure acquisition of elastomeric O-rings with a surface quality level adequate for their intended use. To achieve this objective, this standard:

- (a) Includes illustrations and supplementary definitions and dimensions to identify O-ring surface imperfections for "the purpose of inspection, and
- (b) Establishes quantitative levels of acceptance for O-rings relative to surface imperfections, type, size and quantity.

1.1.1 In general, this standard is intended to supplement the inspection procedure of a particular specification for O-rings. Where no such procedure is provided, this standard becomes the primary guide. In the event of conflict between this standard and the inspection procedure of an end item specification or a specification for O-rings, the basic specification shall govern.

1.2 Scope. This document covers only visible imperfections of O-rings.

## 2. REFERENCED DOCUMENTS

2.1 Issues of documents. The following documents, of the issue in effect on date of invitation for bids or request for proposal, form a Part of this standard to the extent specified herein.

### STANDARDS

#### MILITARY

- MIL-STD-105 - Sampling Procedures and Tables for Inspection by Attributes.
- MIL-STD-109 - Quality Assurance Terms and Definitions.

(Copies of specifications, standards, drawings, and publications required by contractors in connection with specific acquisition functions should be obtained from the contracting activity or as directed by the contracting officer.)

## 3. DEFINITIONS

3.1 MIL-STD-105 and MIL-STD-109 define critical, major and minor defects. The classification of an O-ring defect as "critical" requires knowledge of the end use; therefore, critical defects are not included in this standard but must be, considered in the basic specification(s). O-rings inspected for surface imperfections in accordance with this standard are determined to be either acceptable or unacceptable. The concept of minor defects is not applicable.

MIL-STD-413C  
8 December 1980

3.2 The following word descriptions apply to the visible imperfections covered in this standard:

- (a) Backrind. A longitudinal recess of wide angle U-like or W-like cross-sections, oriented circumferentially and located at parting lines, caused by thermal expansion over sharp mold edge or by premature cure.
- (b) Blister. A void or a hole in the body of the O-ring, which may or may not cause protrusion on the surface and may be covered or open, caused by air being trapped during cure.
- (c) Bloom. Material which has migrated from the body of the O-ring to the O-ring surface.
- (d) Excessive trimming. Flat spots or nicks, producing out-of-tolerance cross-section, caused by excessive buffing or trimming of flash. An O-ring is considered "excessively trimmed" only if a flat area results to the extent that an out-of-tolerance condition exists. Even when an O-ring has not been "excessively trimmed", it could have an imperfect trim or buff condition. "Imperfect trim or buff" is a condition, wherein abrasion, scuffing or tearing, generated when removing flash or parting line projection, result in a substantially coarser texture. Protruding O-ring material or a heavily abraded surface are the indicators of "imperfect trim" and are not acceptable on any size O-ring.
- (e) Flash. Very thin gage, sometimes film-like, material which extends from parting line projection, resulting from mold separation or inadequate trim.
- (f) Flow mark. A thread-like recess, usually curved, of very slight depth in the unflexed state, with normal surface texture and radiused edge. It is caused by incomplete flow and knit of the material.
- (g) Foreign material. Any extraneous, embedded matter (such as contamination, dirt, or undispersed pigment) or depression, formed by its removal.
- (h) Mismatch. The cross-sectional radius in one ring half is unequal to that of the other half. It is caused by the dimensional difference in mold halves.
- (i) Mold deposit indentations. Surface indentations, irregular in shape, with rough surface texture, caused by a build-up of hardened deposits, adhering to the mold cavity.
- (j) Non-fill. A randomly spaced, irregularly shaped, surface indentation, having a coarser texture, than the normal O-ring surface.
- (k) Off-register. Misaligned O-ring halves, caused by the lateral shift of one mold cavity plate, relative to the other.
- (l) Parting line indentation. A shallow, saucer-like recess, located on the parting line, caused by a deformity in mold edge.

MIL-STD-413C  
8 December 1980

- (m) Parting line projection. A continuous ridge of material, situated on the parting line, caused by worn or otherwise excessively rounded mold edges.
- (n) Porosity. Presence of numerous minute voids or sponginess, showing up usually in a cross-section cut.

#### 4. GENERAL REQUIREMENTS

4.1 Examination conditions. The illumination during examination shall be 400-foot candles, minimum. Bloom or surface dust, if present on the O-ring, shall be removed before inspection.

#### 4.2 Identification of imperfections.

4.2.1 Enlarged photographs of representative, acceptable and unacceptable imperfections are included to aid inspection (see figures 1 through 86). The grid sizes are 0.1, 0.2, 0.3, 0.5 and 1.0 inch for 1x, 2x, 3x, 5x, and 10X magnification, respectively.

4.2.2 Arrows have been added to selected 10X magnification photographs for aid in identifying the imperfection shown. 3X power magnification, however, shall be used to aid in the detection of imperfections, unless otherwise specified by the contract.

4.2.3 All photographs are indexed in table I, according to figure number, O-ring size (W), type of imperfection and classification of imperfection (acceptable and unacceptable). For some types of imperfections, exaggerated line drawings are included to supplement the photographs and to illustrate the nature of the imperfections more vividly (see figure 87).

4.2.4 It should be borne in mind that this standard has included photographs of only the most common imperfections that occur during the fabrication of elastomeric O-rings. It is not feasible to obtain photographs to show clearly all possible imperfections in all sizes. Further, the definitions of imperfections in this standard do not abrogate requirements of a particular specification, contract or order. Where other types of imperfections such as cracks or ruptures are found, the general workmanship criteria of 5.1 shall govern.

#### 4.3 Evaluation of imperfections.

4.3.1 For the purpose of visual examination, it is recommended that inspectors use, for reference and comparison, wire gauges or other type devices in diameters of 0.002; 0.005; 0.010; 0.015; and 0.020 inch (or 0.05; 0.13; 0.25; 0.38; and 0.51 millimeters (mm)). Such gauges shall be positioned adjacent to imperfections for their size determination.

4.3.2 Quantitative classification of acceptable and unacceptable imperfections is shown in table II (showing dimensions in inches) and in table III (showing dimensions in mm). When any dimension of an imperfection exceeds the value specified in tables II or III, as applicable, this constitutes an unacceptable imperfection for any O-ring having a cross-sectional width, "W", within the range shown. Otherwise, the imperfection

MIL-STD-413C  
8 December 1900

is classified as acceptable. In general, the dimensional limits of imperfections are related to the O-ring cross-sectional width. For O-ring sizes appreciably larger than 0.275 inch (6.98 mm) cross-sectional width, quality assurance personnel should refer to the particular specification involved for quantitative dimensional limits of imperfections.

5. DETAILED REQUIREMENTS

5.1 Nondestructive tests. In all cases, including where a conflict exists with this standard, the requirements of the applicable specification shall govern. Workmanship and finish shall be in accordance with the highest grade practice in manufacturing this kind of product. Manufacturing practices shall be such that the physical properties of the finished product shall be uniform in quality and condition, clean, smooth and free from cracks, ruptures, porosity, blisters, foreign materials or other imperfections detrimental to the performance of the parts, as further defined herein.

5.1.1 Each O-ring sampled shall be carefully examined for visible surface imperfections (see section 4, and tables I, II, and III). Unacceptable imperfections (those which exceed the dimensional limits in tables II and III, as applicable, or those described in 5.2), shall be cause for rejection of O-rings.

5.2 Rejection of individual O-rings. Rejection of individual O-rings shall be based on the following:

- (a) Each O-ring found to have out-of-tolerance dimensions shall be rejected.
- (b) Visual surface imperfections shall be cause for rejection, as follows:

Any O-ring with one or more unacceptable surface imperfection.

Any O-ring with radially oriented flow mark, regardless of length.

Any O-ring exhibiting poor general appearance, as defined in 5.1.

Such rejection applies equally to surface imperfections found on O-rings inspected for any requirement under the applicable specification. Also, any O-ring which was part of a sample shall be rejected if it contains one or more unacceptable imperfections, regardless of whether its lot or batch as a whole is accepted or rejected.

5.3 Sampling. All O-rings shall be subjected to one or more MIL-STD-105 sampling procedures, as specified by the contracting activity, except where the material specification includes a sampling plan. Unless specified otherwise in the material specification, purchase order or

MIL-STD-413C  
8 December 1980

contract, an Acceptable Quality Level (AQL) of 1.5 percent defective shall used . Acceptance or rejection of the lot, sub-lot or batch shall be on this basis, except where already rejected in 5.1. In the application of MIL-STD-105 to this standard, the following shall be noted:

- (a) Inasmuch as inspection to this standard is to determine whether O-rings are either acceptable or unacceptable and in view of 3.1, minor and critical defects do not apply.
- (b) Any sampled O-ring which is rejectable, as indicated in 5.2, shall be considered defective for the determination of the acceptance or rejection of the lot it represents.

Custodians :

Army - MI  
Navy - SH  
Air Force - 99

Review activities:

Navy - OS, AS  
Air Force - 11

User activities:

Army - AT  
Navy - MC

Preparing activity:

Navy - SH  
(Project 5330-0532)

TABLE I. Index to photographs of representative acceptable and unacceptable surface imperfections.

| Surface imperfection                       | Figure numbers for values of "W" shown |                     |                     |                     |                     |
|--|--|---------------------|---------------------|---------------------|---------------------|
|  | 0.070"<br>(1.78 mm)                    | 0.103"<br>(2.62 mm) | 0.139"<br>(3.53 mm) | 0.210"<br>(5.33 mm) | 0.275"<br>(6.98 mm) |
| Backrind, unacceptable                     | 1                                      | 2, 3, 4             | 7                   | 10                  | --                  |
| Backrind, acceptable                       | -----                                  | 5, 6                | 8                   | 9                   | --                  |
| Parting line indentation, unacceptable     | 14                                     | 18                  | 19, 20, 22          | 24                  | --                  |
| Parting line indentation, acceptable       | 11, 12, 13                             | 15, 16, 17          | 21                  | 23                  | --                  |
| Foreign material, unacceptable             | -----                                  | 26, 28              | 30                  | 32                  | 33                  |
| Foreign material, acceptable               | -----                                  | 25, 27              | 29, 31              | -----               | --                  |
| Excessive trimming, unacceptable           | -----                                  | 35, 37              | 39                  | -----               | 41                  |
| Excessive trimming, acceptable             | -----                                  | 34, 36              | 38                  | 40                  | --                  |
| Excessive flash, unacceptable              | -----                                  | 42, 43, 44          | 47, 49              | -----               | 51                  |
| Excessive flash, acceptable                | -----                                  | 45                  | 46, 48              | 50                  | --                  |
| Non-fill, unacceptable                     | 52                                     | 53                  | 55, 56              | 57, 58              | 60                  |
| Non-fill, acceptable                       | -----                                  | -----               | 54                  | -----               | 59                  |
| Mold deposit indentations, unacceptable    | 61                                     | -----               | 64, 65, 66          | -----               | 69                  |
| Mold deposit indentations, acceptable      | -----                                  | 62                  | 63, 67              | 68                  | --                  |
| Flow marks, unacceptable                   | 70                                     | -----               | 71, 73, 75, 76      | -----               | --                  |
| Flow marks, acceptable                     | -----                                  | -----               | 72, 74, 77          | 78                  | --                  |
| Off-register and/or mismatch, unacceptable | 79                                     | 80                  | 81                  | 86                  | --                  |
| Off-register and/or mismatch, acceptable   | -----                                  | -----               | 82, 83, 84          | 85                  | --                  |

NOTES:

1. O-ring size is specified on each individual photograph. On all photographs, grid sizes are 0.1, 0.2, 0.3, 0.5 and 1 inch for the magnifications identified as 1X, 2X, 3X, 5X and 10X, respectively.
2. If no illustration is indicated for the O-ring size under consideration, refer to the closest size illustrated. Note, however, that acceptance is based upon the dimensional values of imperfections, as defined in tables II and III, and the criteria in 5.2.

MIL-STD-413C  
 8 December 1980

TABLE II. Quantitative classification of imperfections, maximum acceptable dimensions in inches.

| O-ring cross-sectional width "W" | Backrind |       | Parting line indentations |       | Foreign material |       | Parting line projection and excessive flash | Non-fill |       | Mold deposit indentations |       | Flow marks |        | Off-register and/or mismatch | O-ring cross-sectional width "W" |
|----------------------------------|----------|-------|---------------------------|-------|------------------|-------|---|----------|-------|---------------------------|-------|------------|--------|------------------------------|----------------------------------|
|                                  | Depth    | Width | Depth                     | Width | Depth            | Width |   | Depth    | Width | Depth                     | Width | Depth      | Length |                              |                                  |
| Less than 0.100                  | 0        | 0     | 0.003                     | 0.010 | 0                | 0     | 0.003                                       | 0        | 0     | 0.003                     | 0.010 | 0.002      | 0.060  | 0.003                        | Less than 0.100                  |
| 0.100 to 0.134                   | 0.003    | 0.005 | 0.003                     | 0.015 | 0.003            | 0.005 | 0.003                                       | 0.002    | 0.010 | 0.003                     | 0.015 | 0.002      | 0.060  | 0.004                        | 0.100 to 0.134                   |
| 0.135 to 0.204                   | 0.004    | 0.006 | 0.004                     | 0.020 | 0.004            | 0.007 | 0.004                                       | 0.003    | 0.015 | 0.004                     | 0.020 | 0.002      | 0.180  | 0.005                        | 0.135 to 0.204                   |
| 0.205 to 0.268                   | 0.004    | 0.006 | 0.005                     | 0.025 | 0.005            | 0.010 | 0.005                                       | 0.003    | 0.025 | 0.004                     | 0.025 | 0.002      | 0.180  | 0.006                        | 0.205 to 0.268                   |
| 0.269 and over                   | 0.005    | 0.010 | 0.006                     | 0.030 | 0.006            | 0.015 | 0.006                                       | 0.003    | 0.040 | 0.005                     | 0.030 | 0.002      | 0.180  | 0.006                        | 0.269 and over                   |

Dimensions of imperfections are acceptable unless they exceed the values specified in the table.

NOTE: Length and width of an imperfection are synonymous except for backrind, parting line projection, excessive flash and flow marks.

MIL-STD-413C  
 8 December 1980

TABLE III. Quantitative classification of imperfections, maximum acceptable dimensions in millimeters.

| O-ring cross-sectional width "W" | Backrind |       | Parting line indentations |       | Foreign material |       | Parting line projection and excessive flash |       | Non-fill |       | Mold deposit indentations |       | Flow marks |       | Off-register and/or mismatch | O-ring cross-sectional width "W" |
|----------------------------------|----------|-------|---------------------------|-------|------------------|-------|---|-------|----------|-------|---------------------------|-------|------------|-------|------------------------------|----------------------------------|
|                                  | Depth    | Width | Depth                     | Width | Depth            | Width | Max. ht.                                    | Depth | Width    | Depth | Width                     | Depth | Width      | Depth |                              |                                  |
| Less than 2.54                   | 0        | 0     | 0.08                      | 0.25  | 0                | 0.08  | 0.08  | 0     | 0        | 0.08  | 0.25                      | 0.05  | 1.52       | 0.08  | Less than 2.54               |                                  |
| 2.54 to 3.42                     | 0.08     | 0.13  | 0.08                      | 0.38  | 0.08             | 0.08  | 0.08  | 0.05  | 0.25     | 0.08  | 0.38                      | 0.05  | 1.52       | 0.10  | 2.54 to 3.42                 |                                  |
| 3.43 to 5.20                     | 0.10     | 0.15  | 0.10                      | 0.51  | 0.10             | 0.18  | 0.10  | 0.08  | 0.38     | 0.10  | 0.51                      | 0.05  | 4.57       | 0.13  | 3.43 to 5.20                 |                                  |
| 5.21 to 6.83                     | 0.10     | 0.15  | 0.13                      | 0.63  | 0.13             | 0.25  | 0.13  | 0.08  | 0.63     | 0.10  | 0.63                      | 0.05  | 4.57       | 0.15  | 5.21 to 6.83                 |                                  |
| 6.84 and over                    | 0.13     | 0.25  | 0.15                      | 0.76  | 0.15             | 0.38  | 0.15  | 0.08  | 1.02     | 0.13  | 0.76                      | 0.05  | 4.57       | 0.15  | 6.84 and over                |                                  |

Dimensions of imperfections are acceptable unless they exceed the values specified in the table.

NOTE: Length and width of an imperfection are synonymous except for backrind, parting line projection, excessive flash and flow marks.

MIL-STD-413C  
8 December 1980

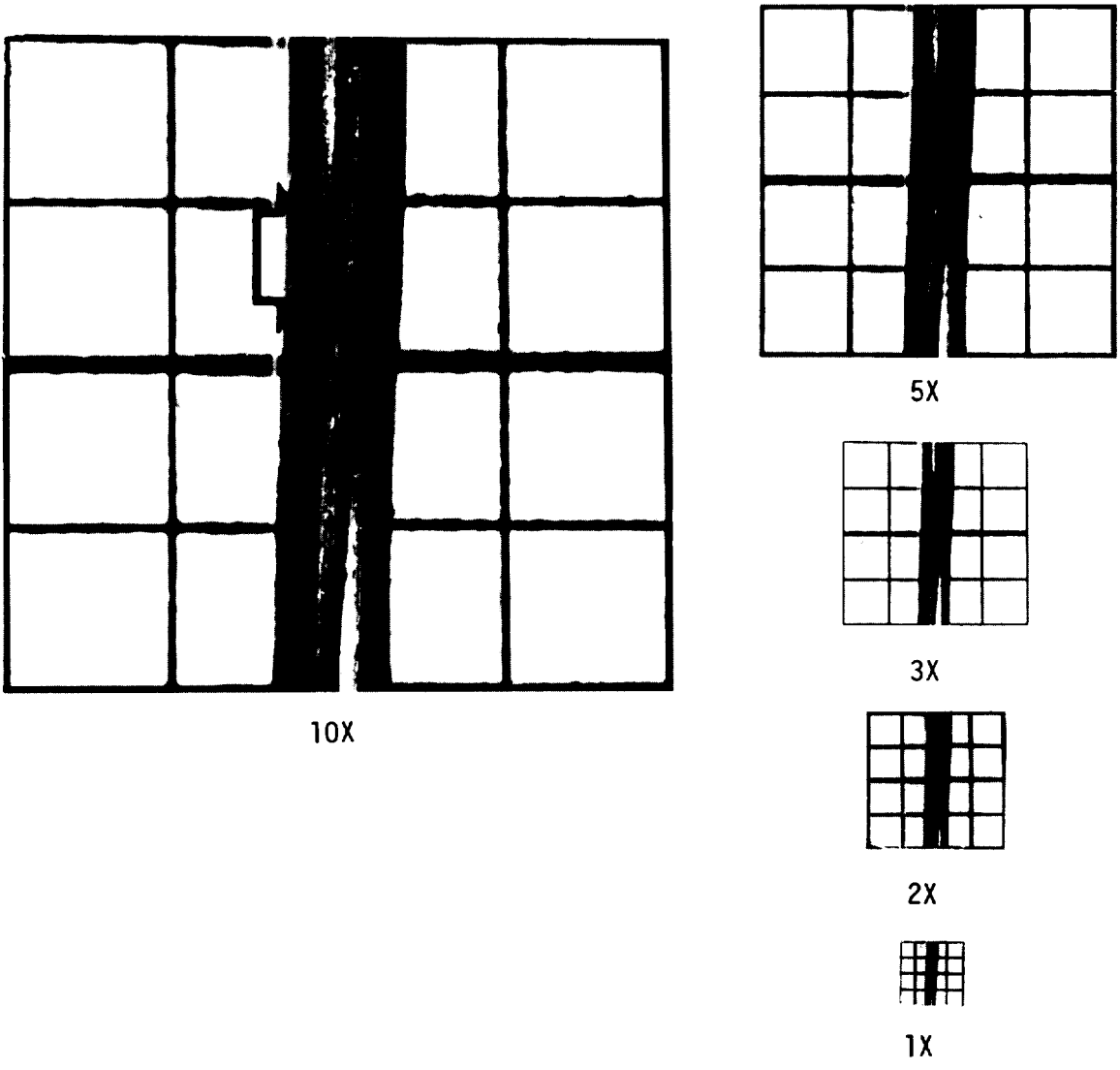

Figure 1 - Backrind, unacceptable,  
W = 0.070" (1.78 mm.)

MIL-STD-413C  
8 December 1980

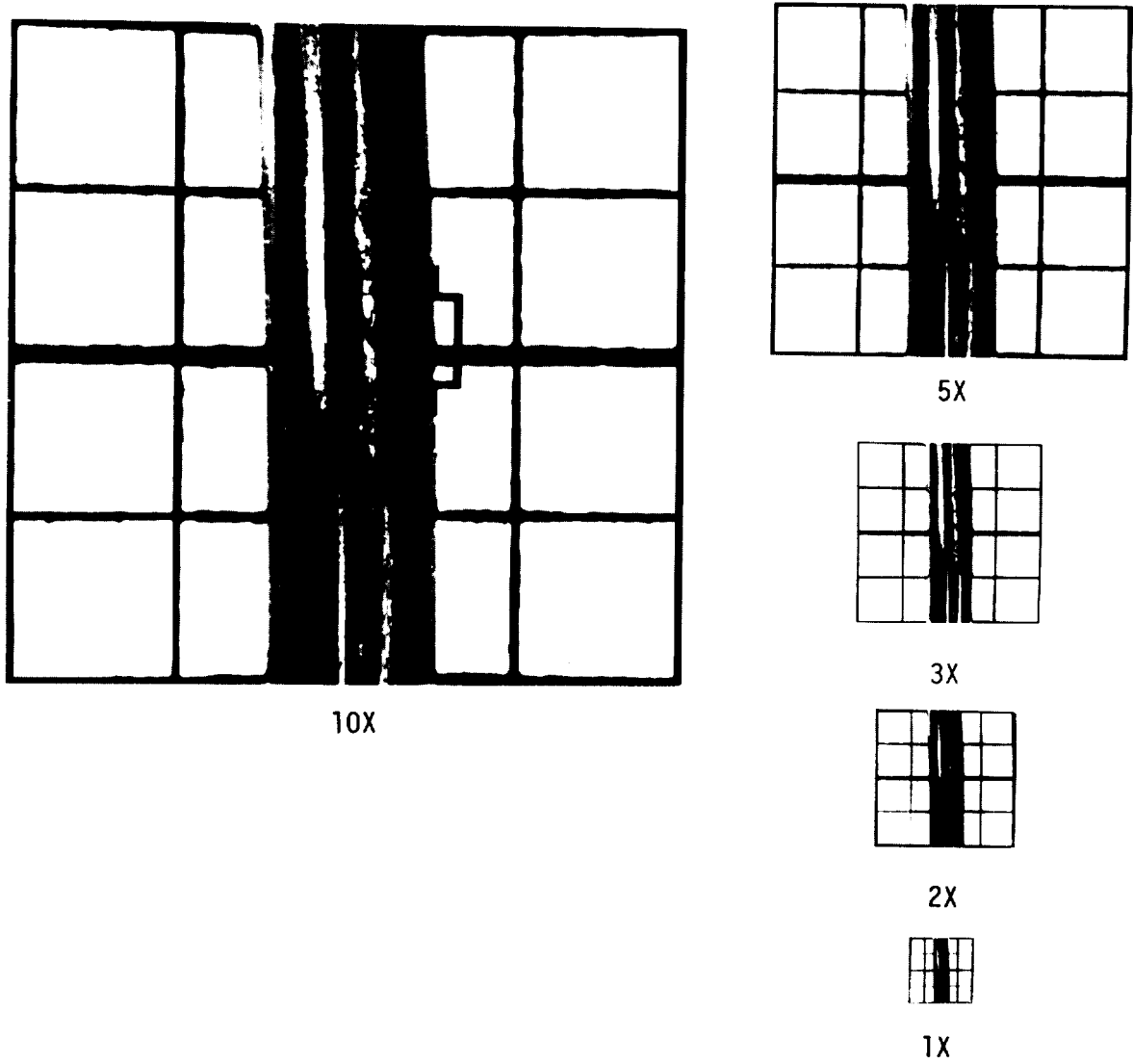

Figure 2 - Backrind, unacceptable,  
W = 0.103" (2.62mm.)

MIL-STD-413C  
8 December 1980

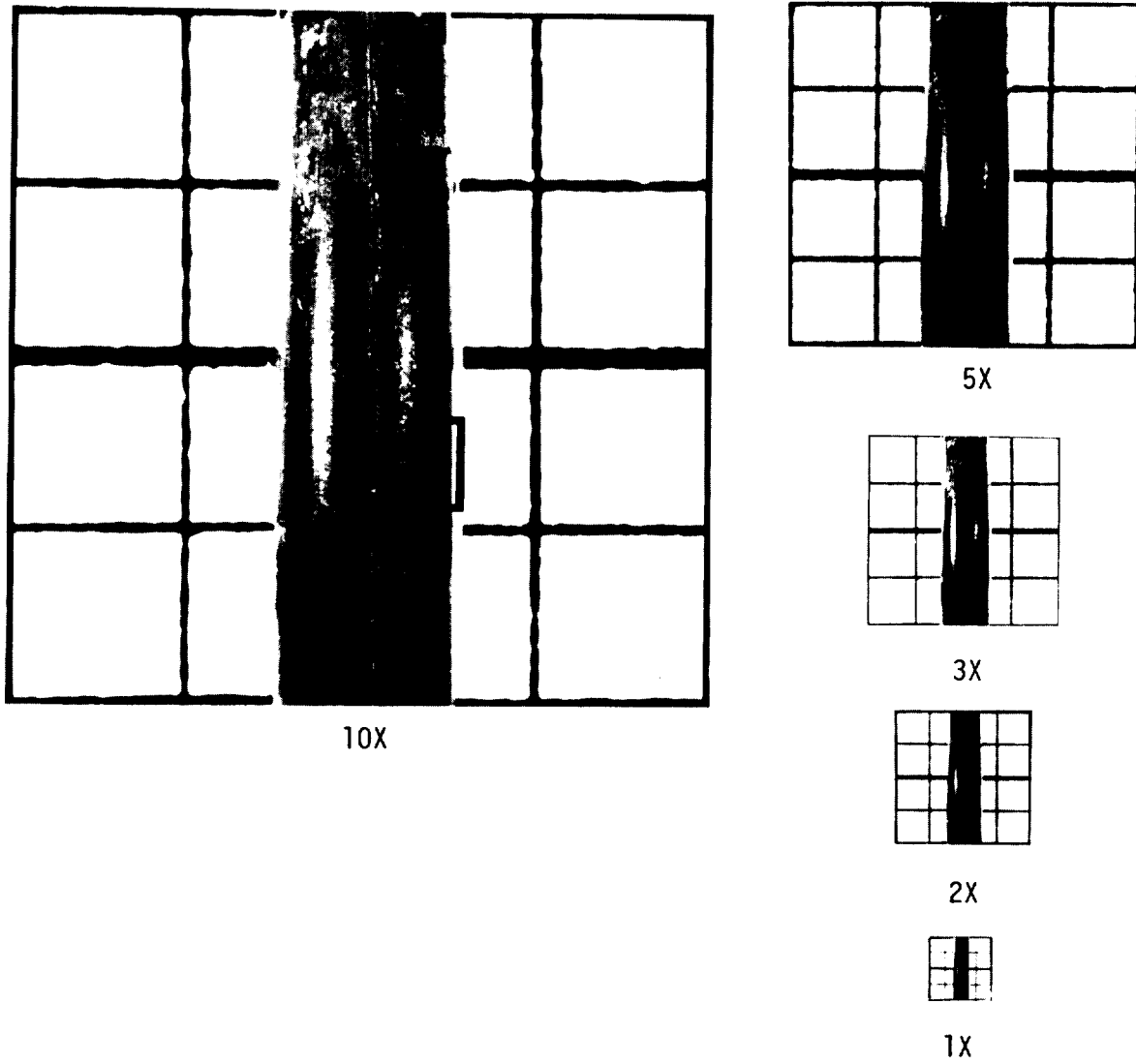

Figure 3 - Backrind, unacceptable,  
W = 0.103" (2.62 mm.)

MIL-STD-413C  
8 December 1980

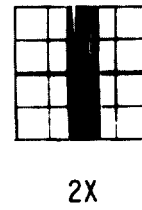
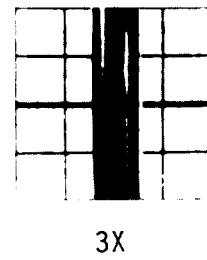
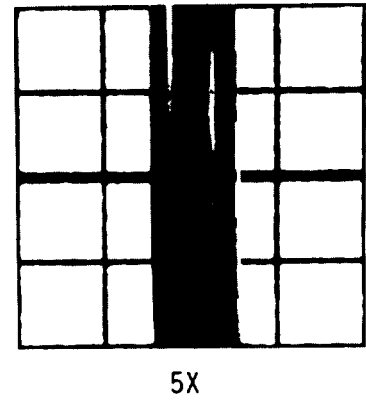
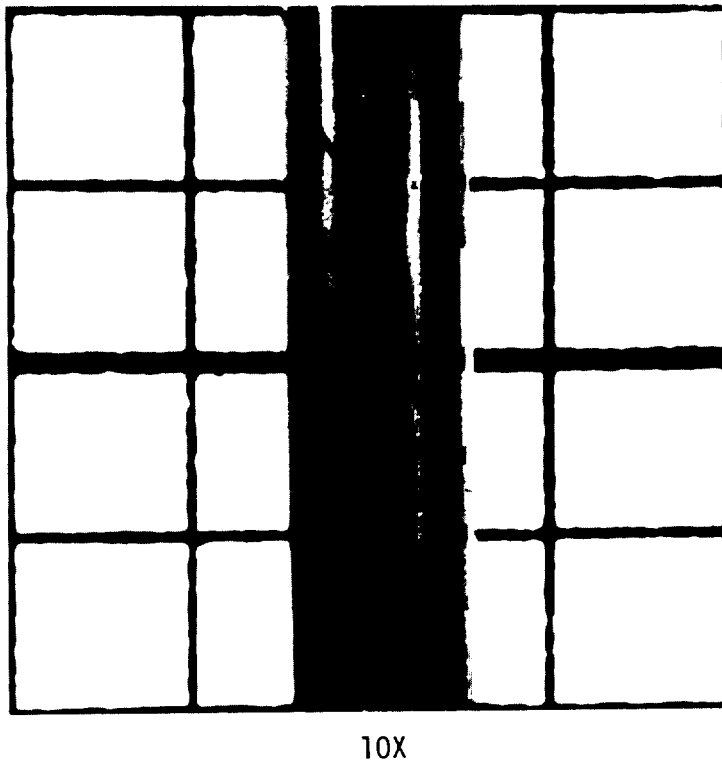

Figure 4 - Backrind, unacceptable,  
W = 0.103" (2.62 mm.)

MIL-STD-413C  
8 December 1980

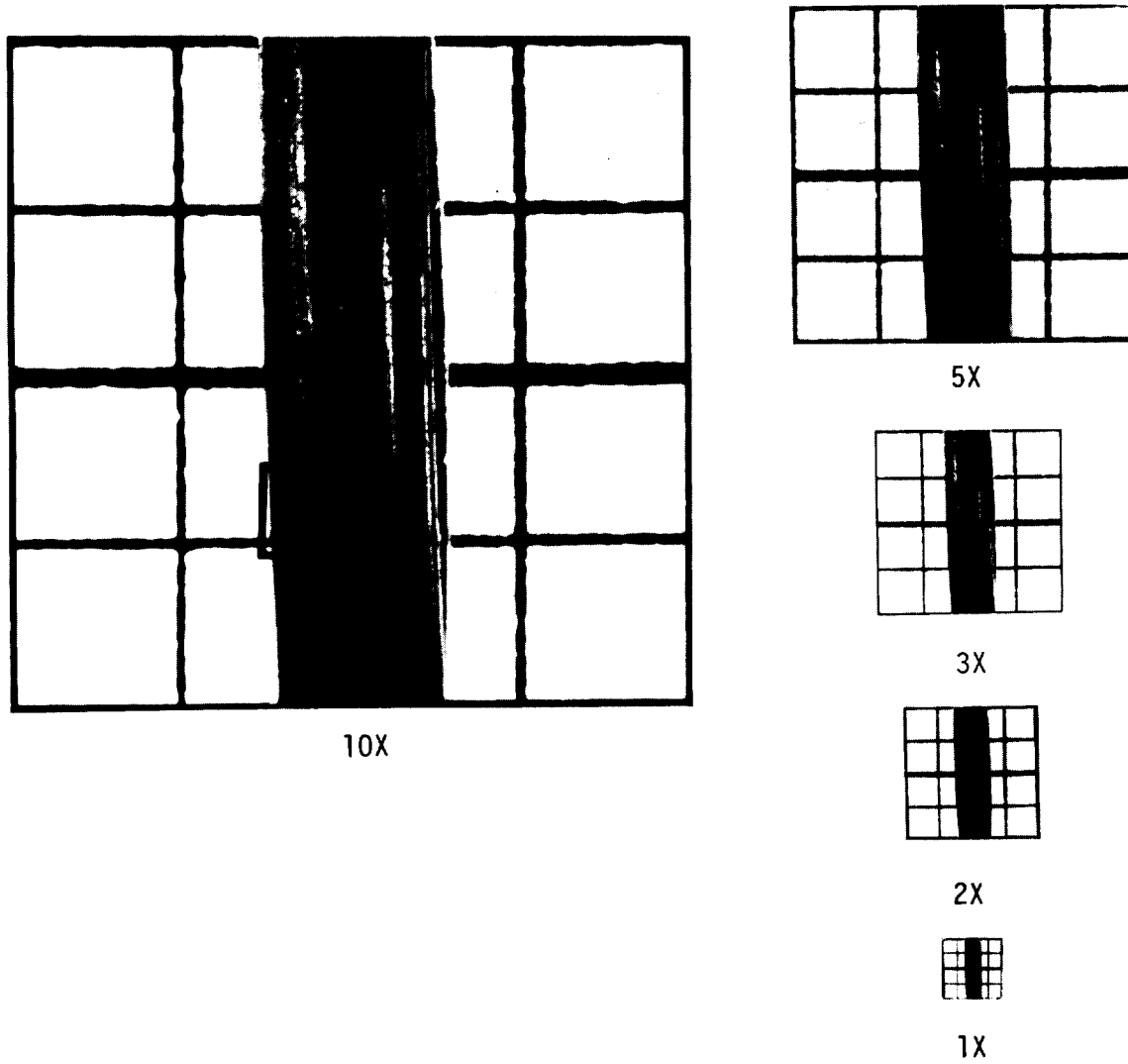

Figure 5 - Backrind, acceptable,  
W = 0.103" (2.62 mm.)

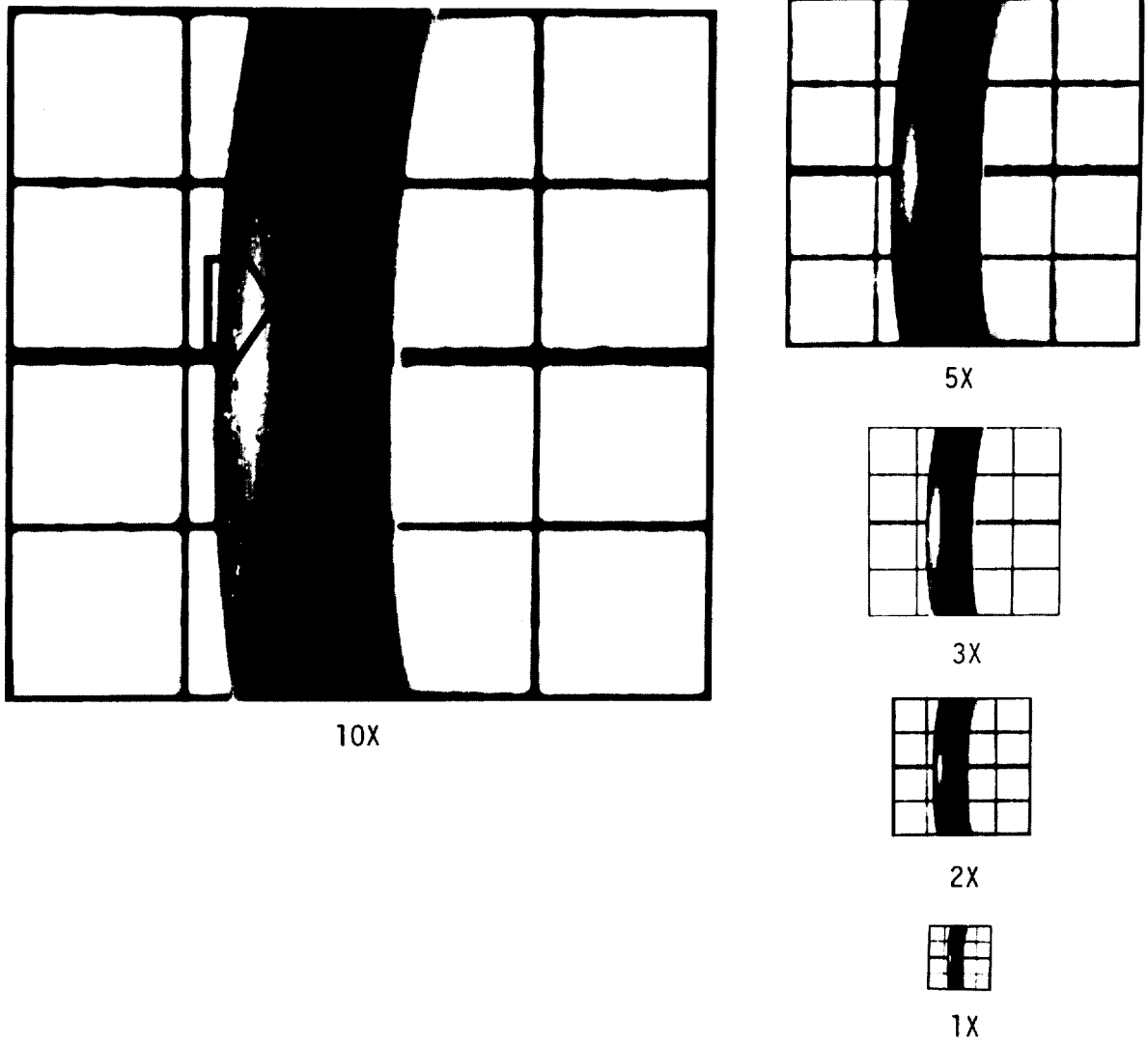

Figure 6 - Backrind, acceptable,  
W = 0.103" (2.62 mm.)

MIL-STD-413C  
8 December 1980

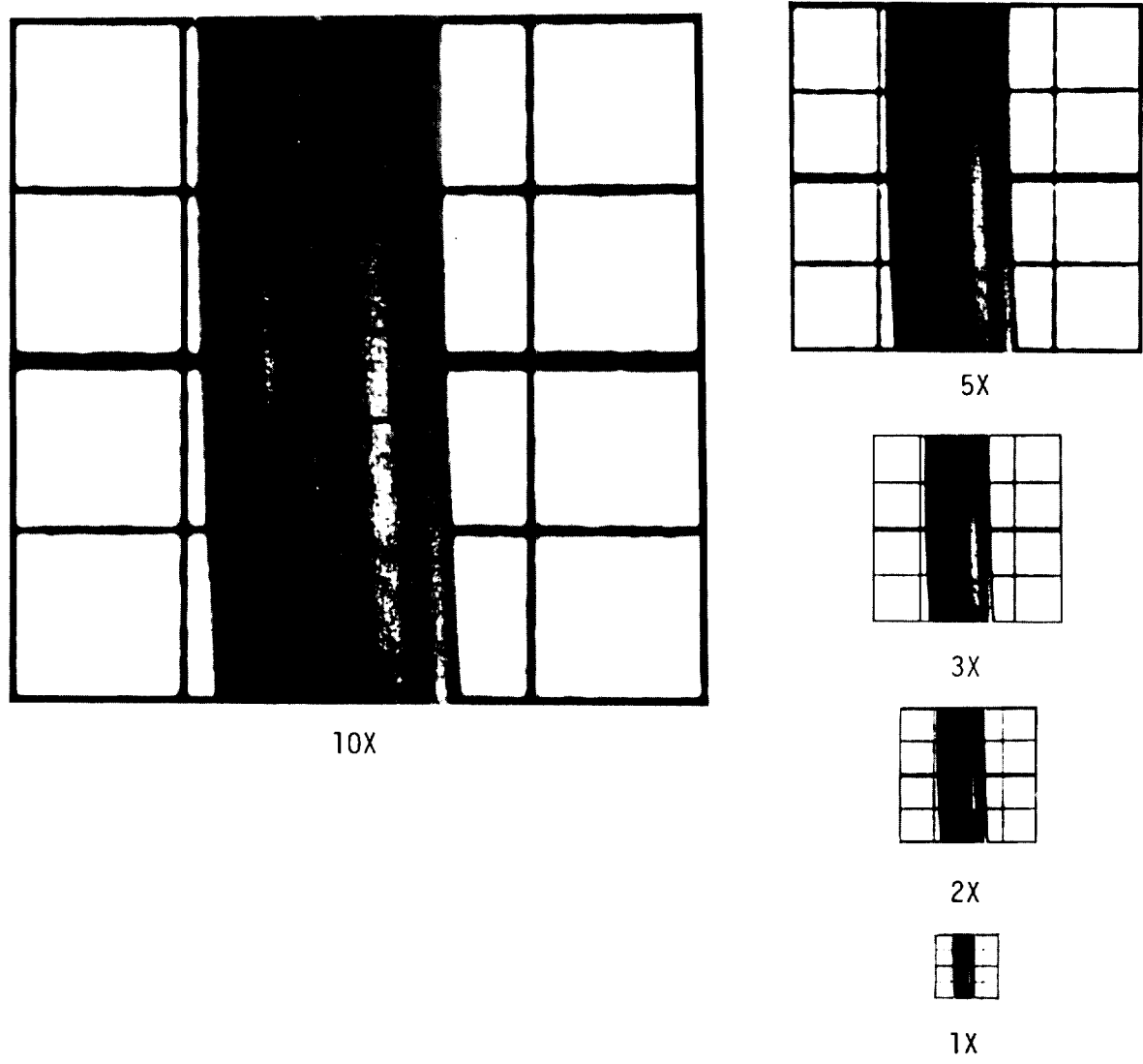

Figure 7 - Backrind, unacceptable,  
W = 0.139" (3.53 mm.)

MIL-STD-413C  
8 December 1980

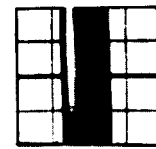
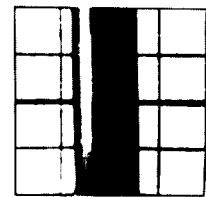
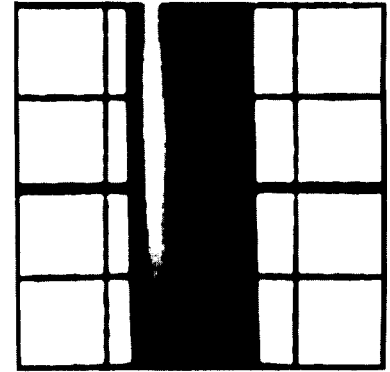
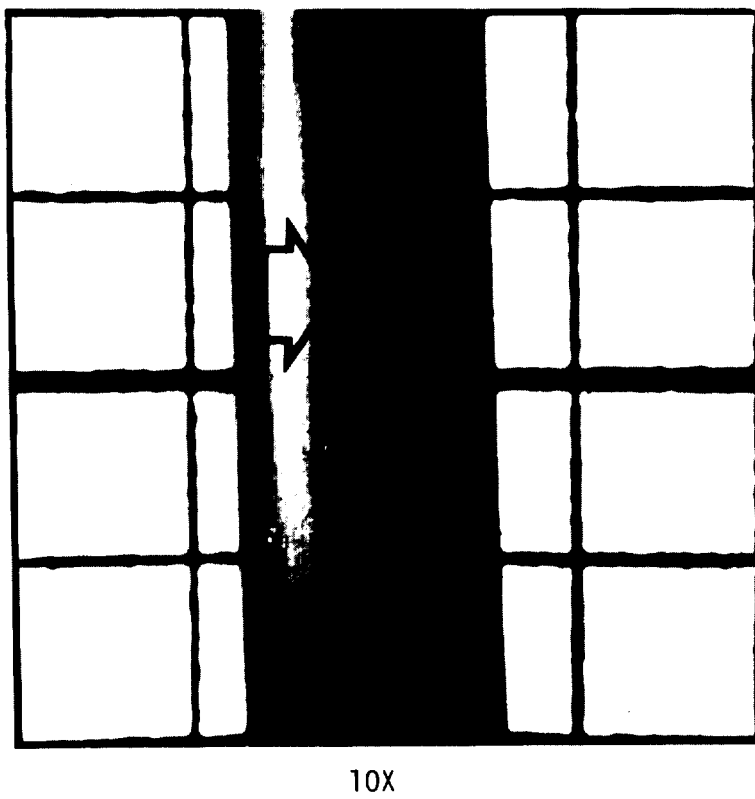

Figure 8 - Backrind, acceptable,  
W = 0.139" (3.53 mm.)

MIL-STD-413C  
8 December 1980

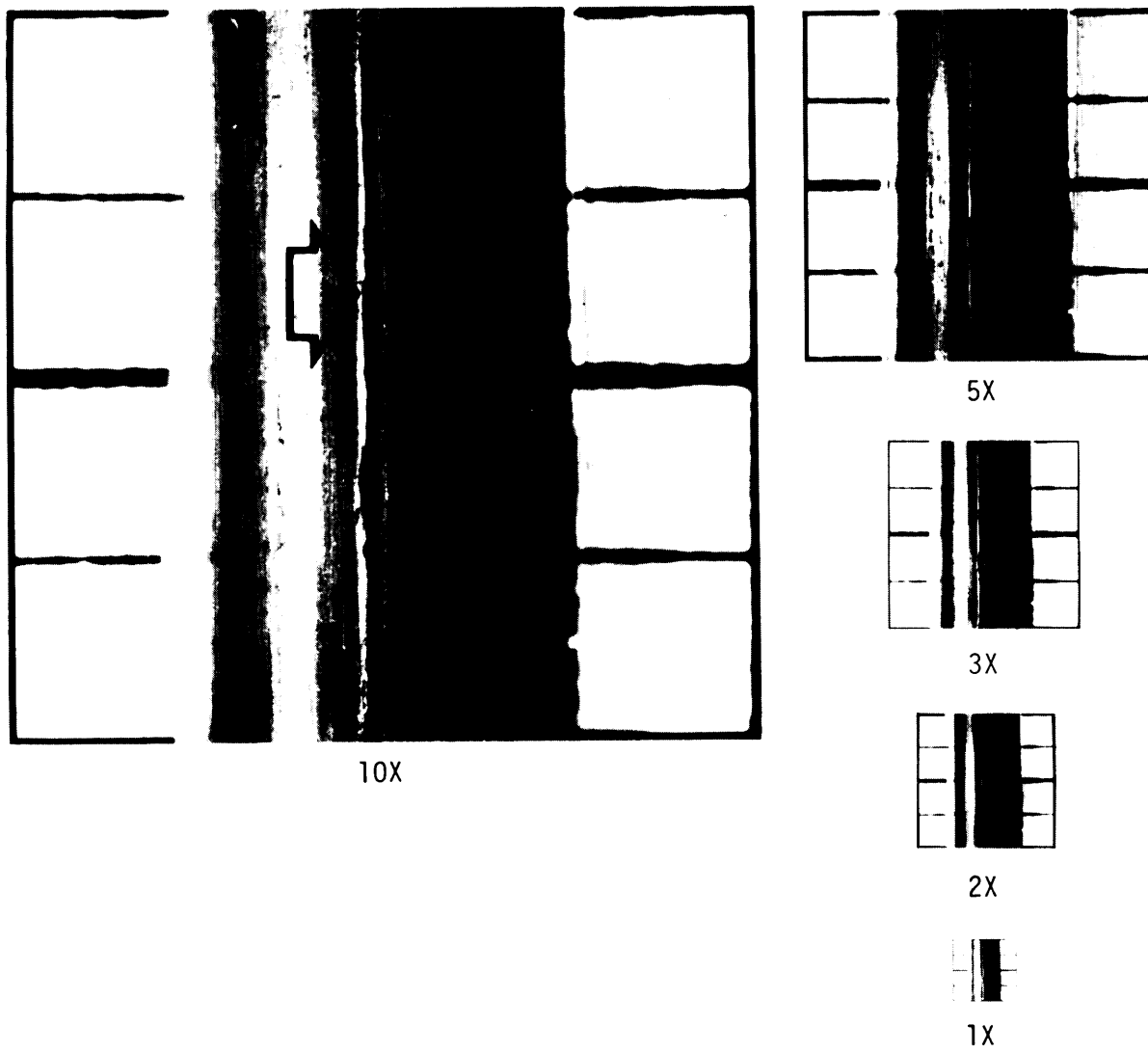

Figure 9 - Backrind, acceptable,  
W= 0.210" (5.33 mm.)

MIL-STD-413C  
8 December 1980

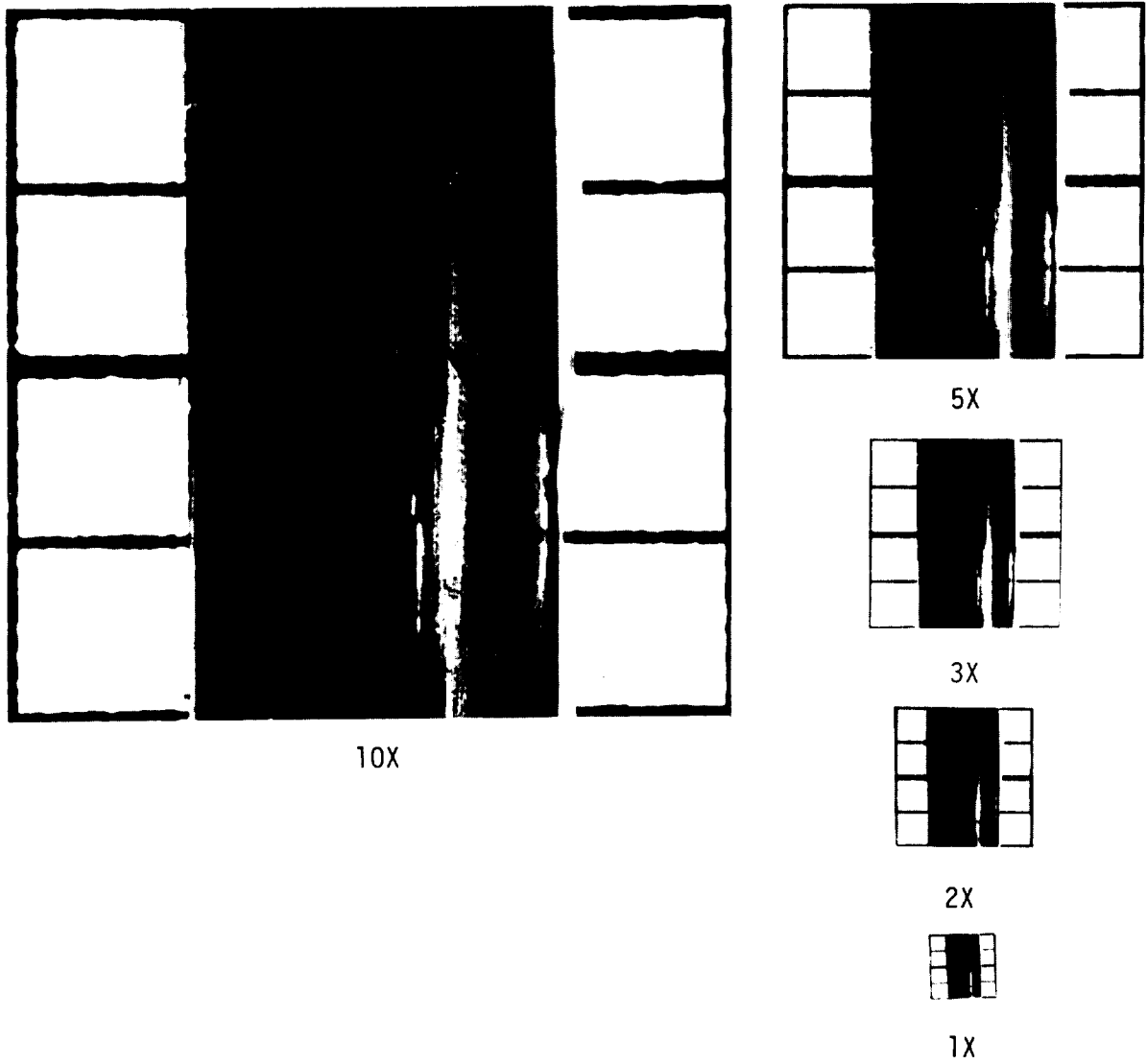

Figure 10 - Backring, unacceptable,  
W = 0.210" (5.33 mm.)

MIL-STD-413C  
8 December 1980

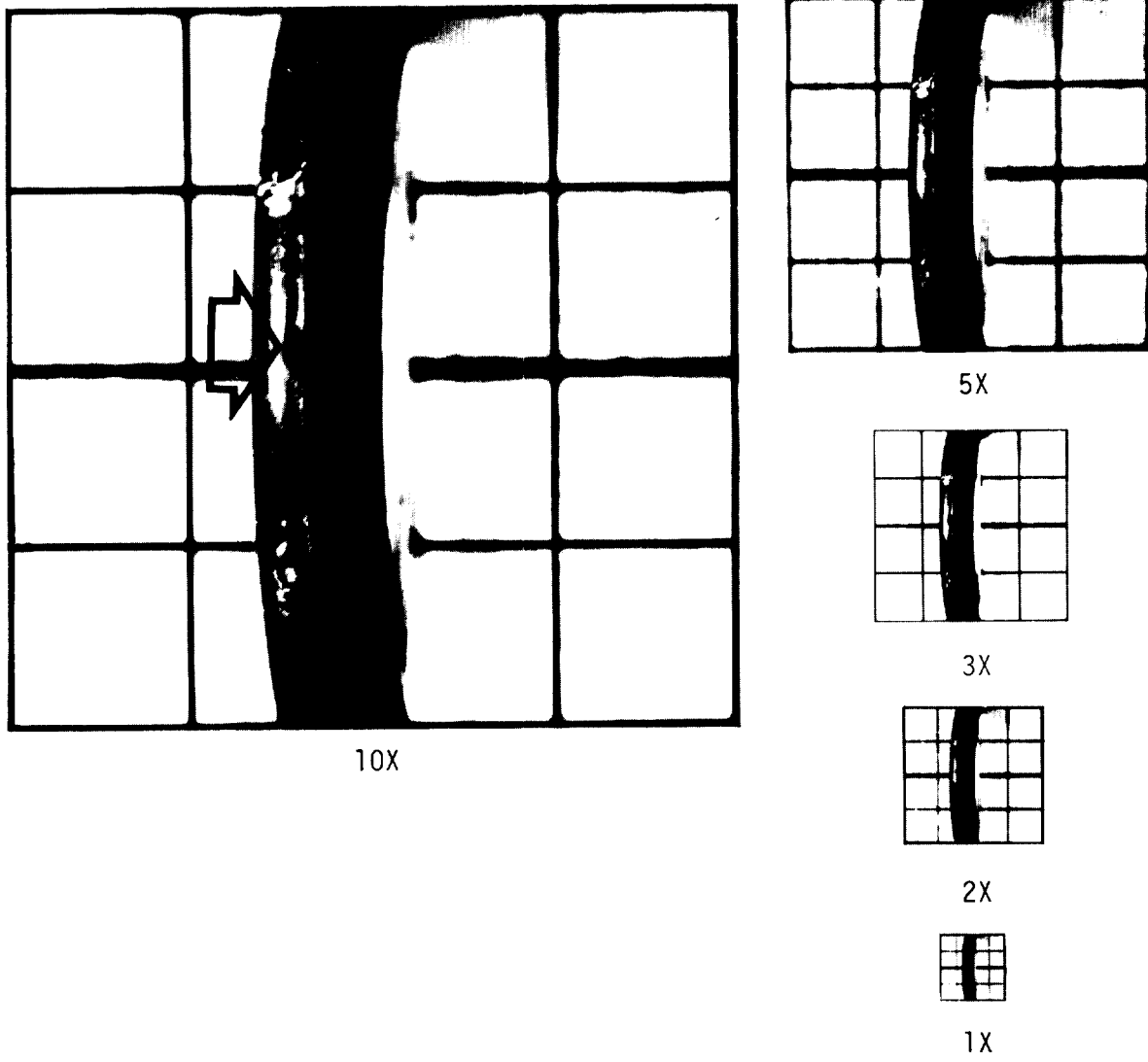

Figure 11 - Parting line indentation,  
acceptable,  
W = 0.070" (1.78 mm.)

MIL-STD-413C  
8 December 1980

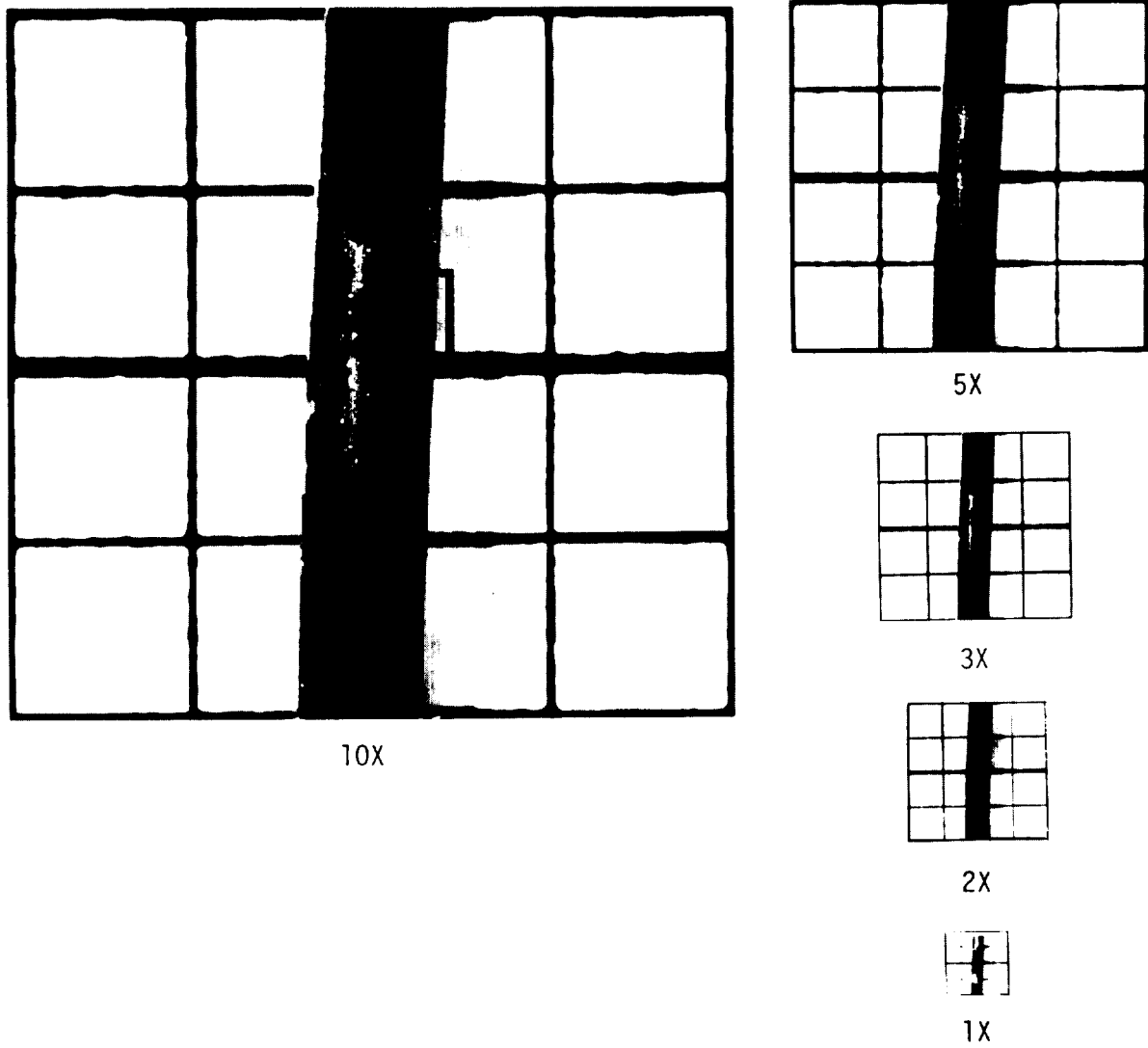

Figure 12 - Parting line indentation,  
acceptable,  
W = 0.070" (1.78 mm.)

MIL-STD-413C  
8 December 1980

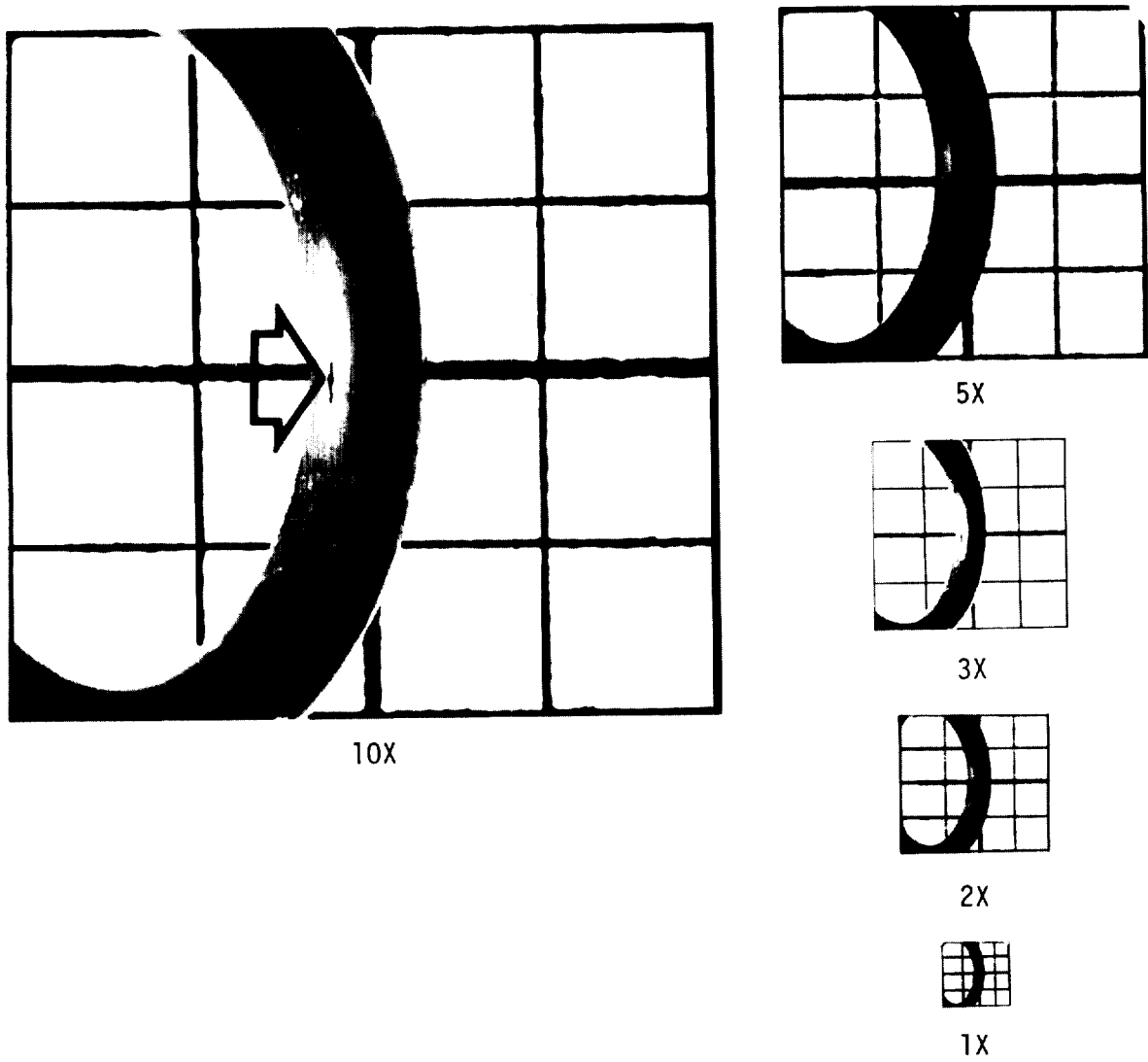

Figure 13 - Parting line indentation,  
acceptable,  
W = 0.070" (1.78 mm.)

MIL-STD-413C  
8 December 1980

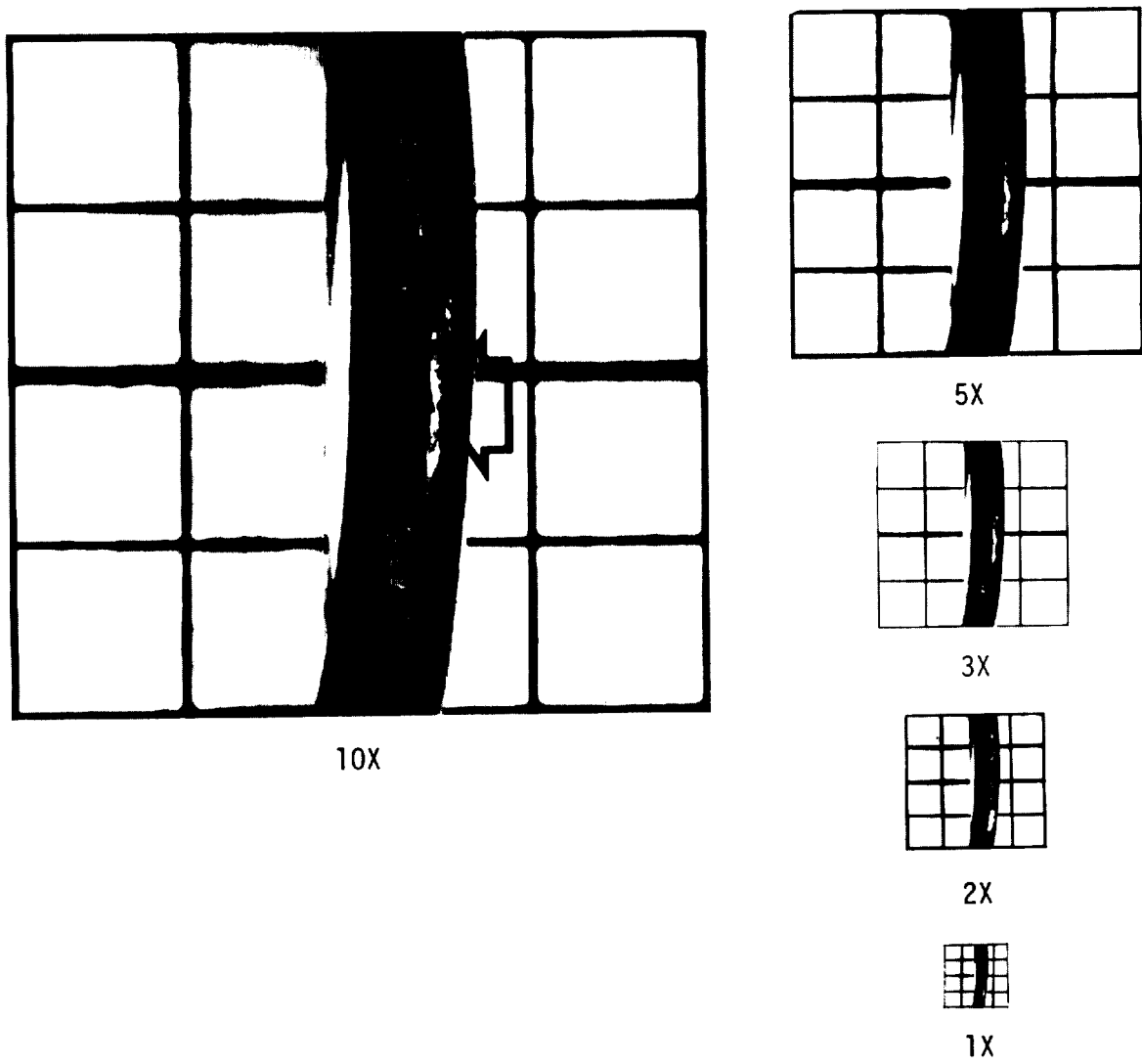

Figure 14 - Parting line indentation,  
unacceptable,  
W = 0.070" (1.78 mm.)

MIL-STD-413C  
8 December 1980

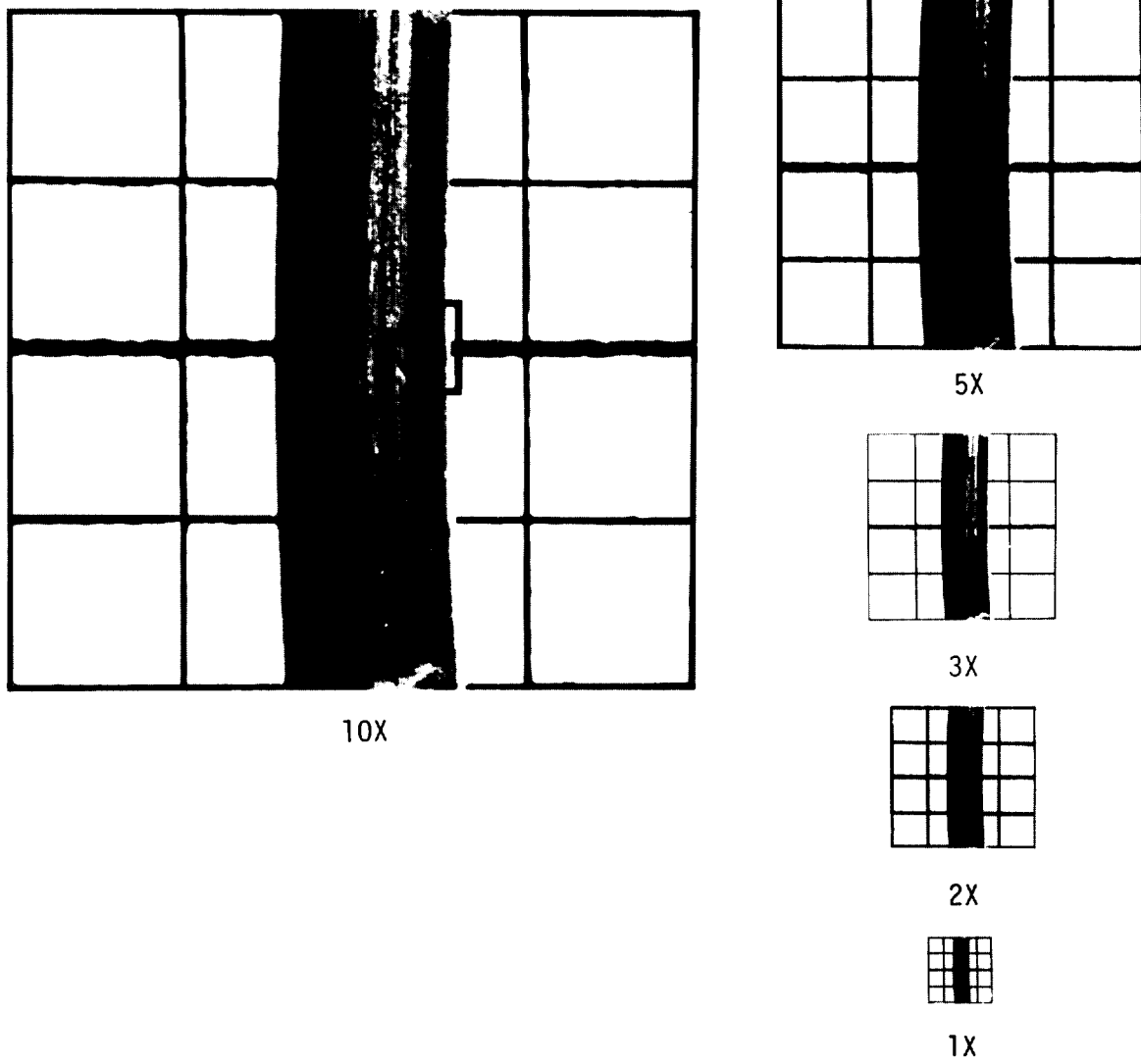

Figure 15 - Parting line indentation,  
acceptable,  
W = 0.103" (2.62 mm.)

MIL-STD-413C  
8 December 1980

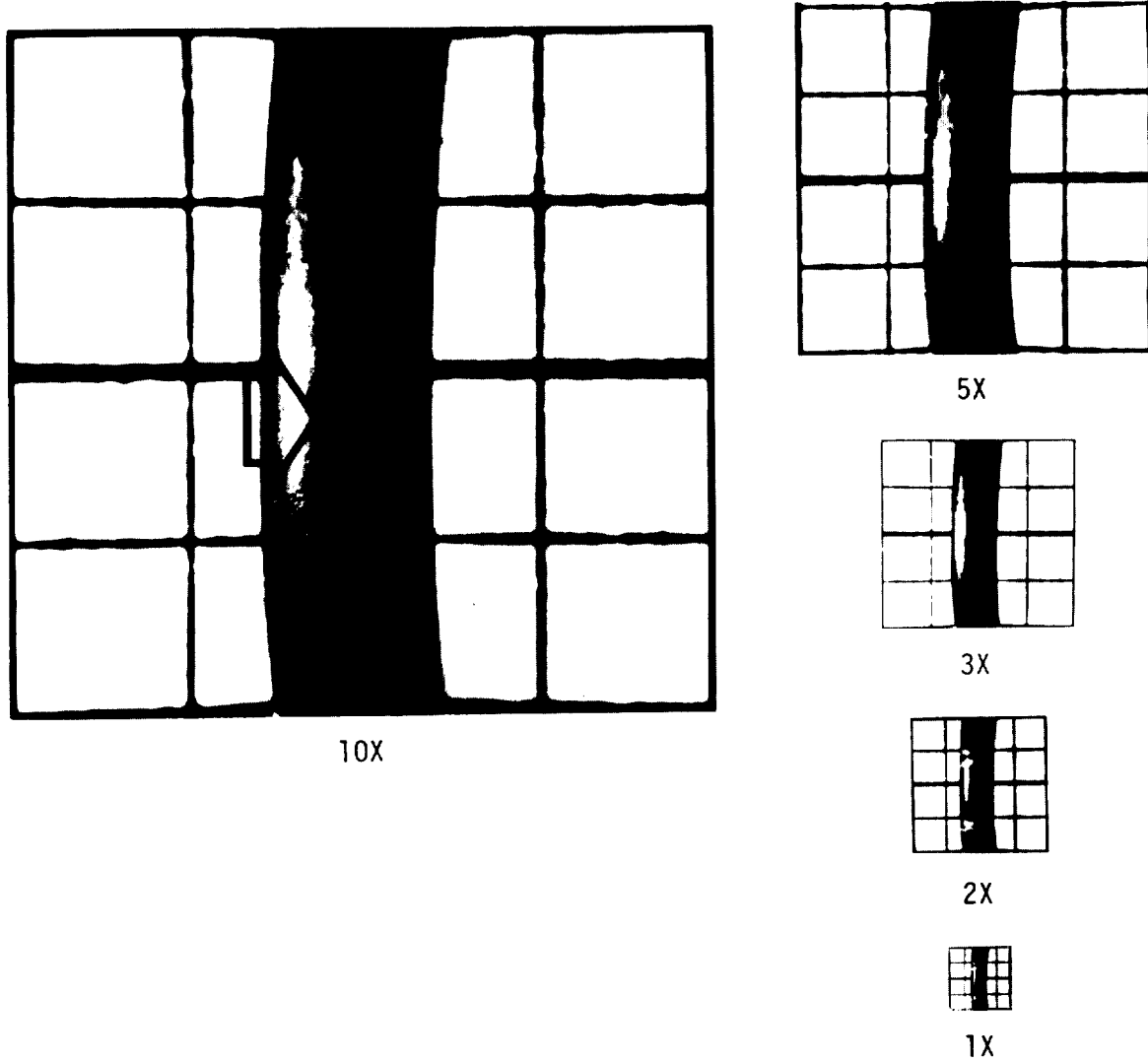

Figure 16 - Parting line indentation,  
acceptable,  
W = 0.103" (2.62 mm.)

MIL-STD-413C  
8 December 1980

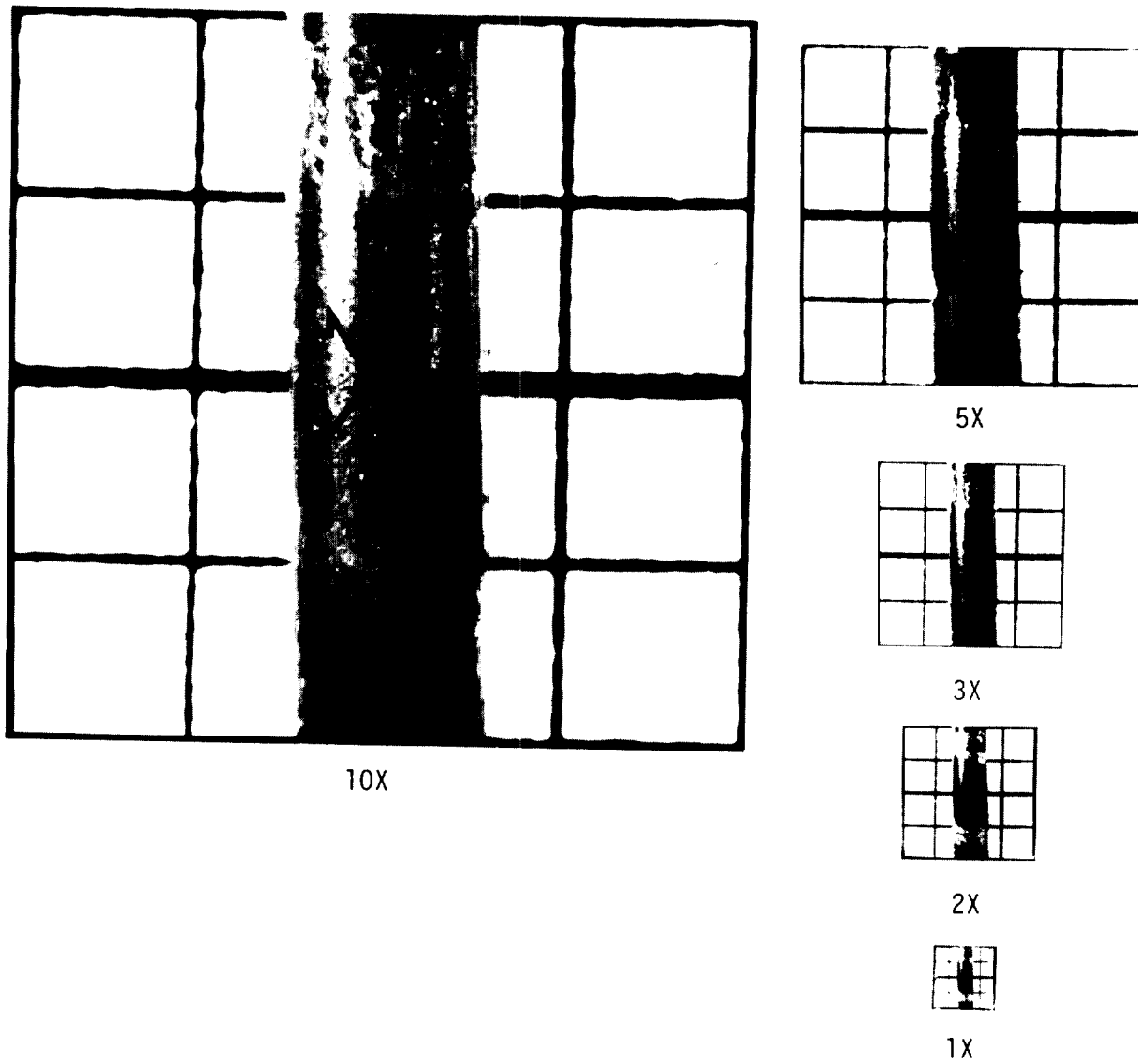

Figure 17 - Parting line indentation,  
acceptable,  
W = 0.103" (2.62 mm.)

MIL-STD-413C  
8 December 1980

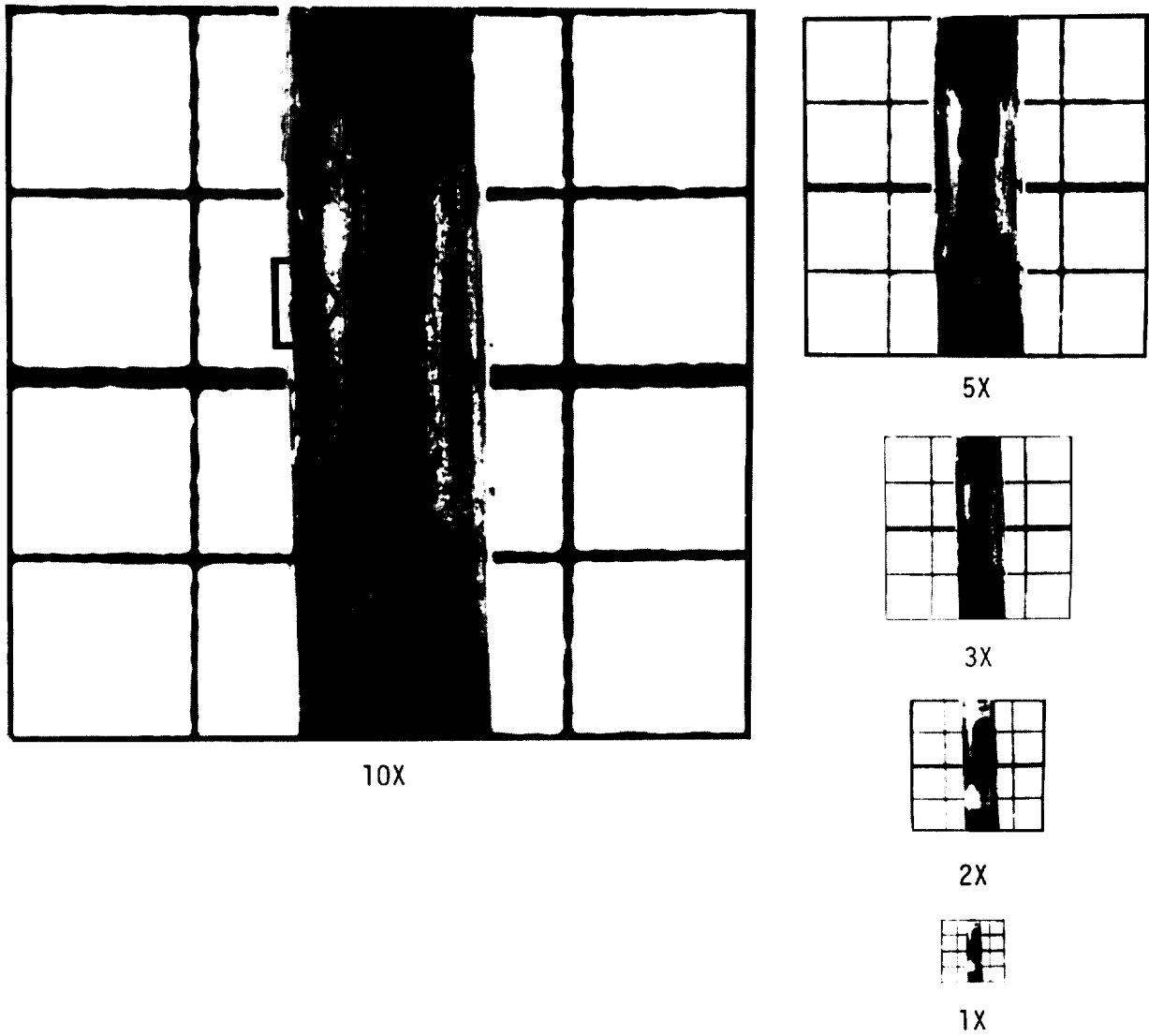

Figure 18 - Parting line indentation,  
unacceptable,  
W = 0.103" (2.62 mm.)

MIL-STD-413C  
8 December 1980

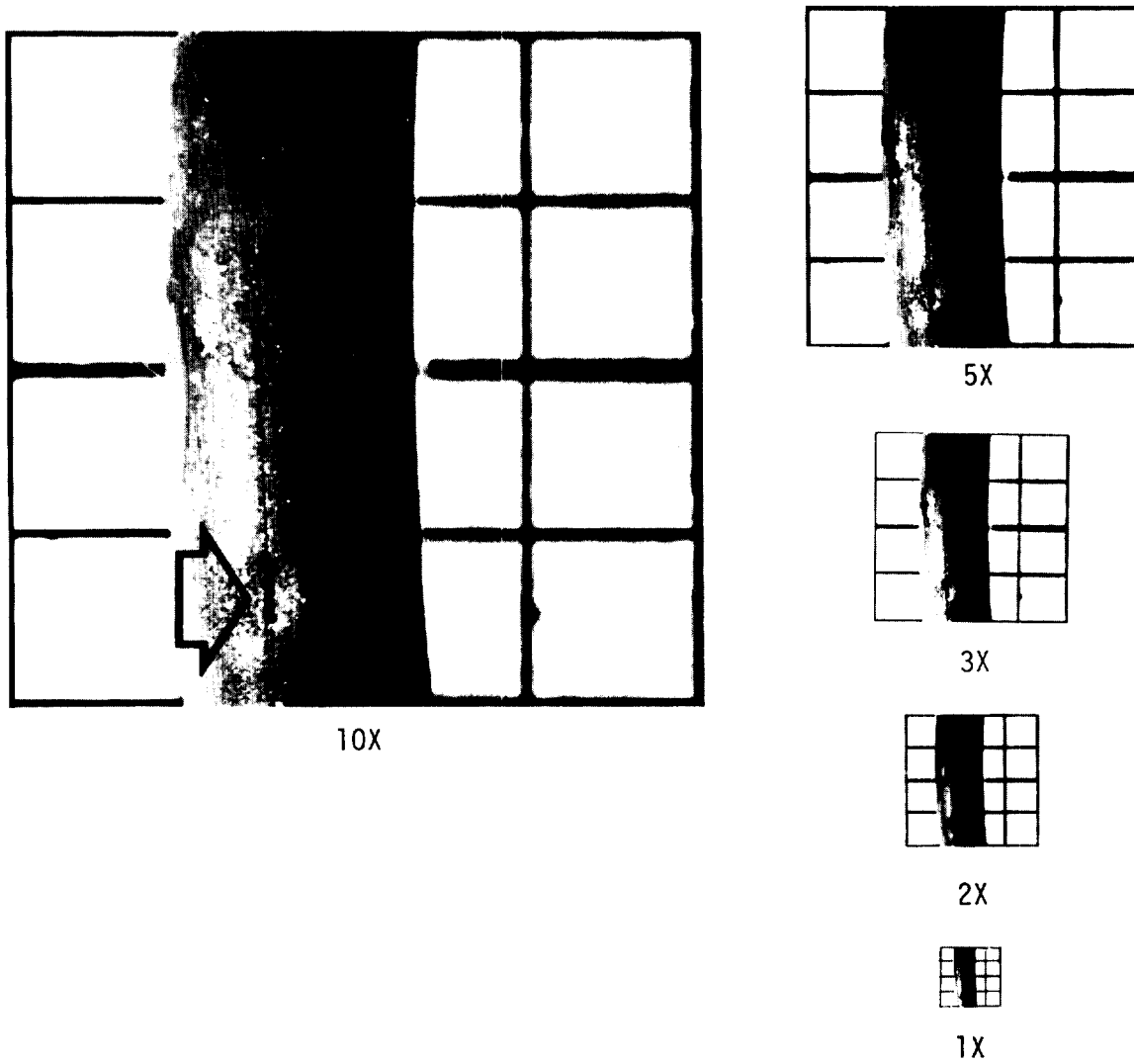

Figure 19 - Parting line indentation,  
unacceptable,  
W = 0.139" (3.53 mm.)

MIL-STD-413C  
8 December 1980

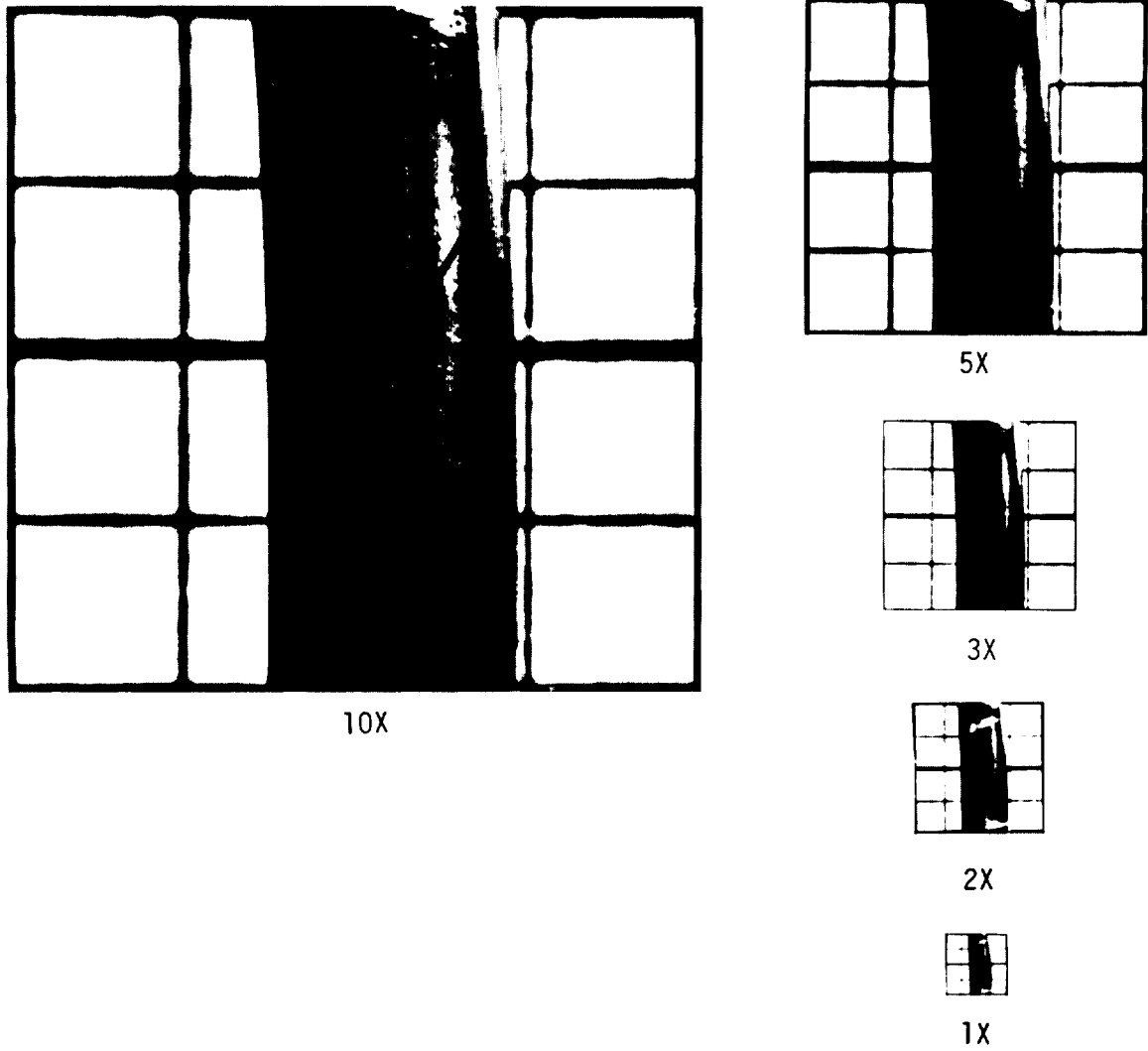

Figure 20 - Parting line indentation,  
unacceptable,  
W = 0.139" (3.53 mm.)

MIL-STD-413C  
8 December 1980

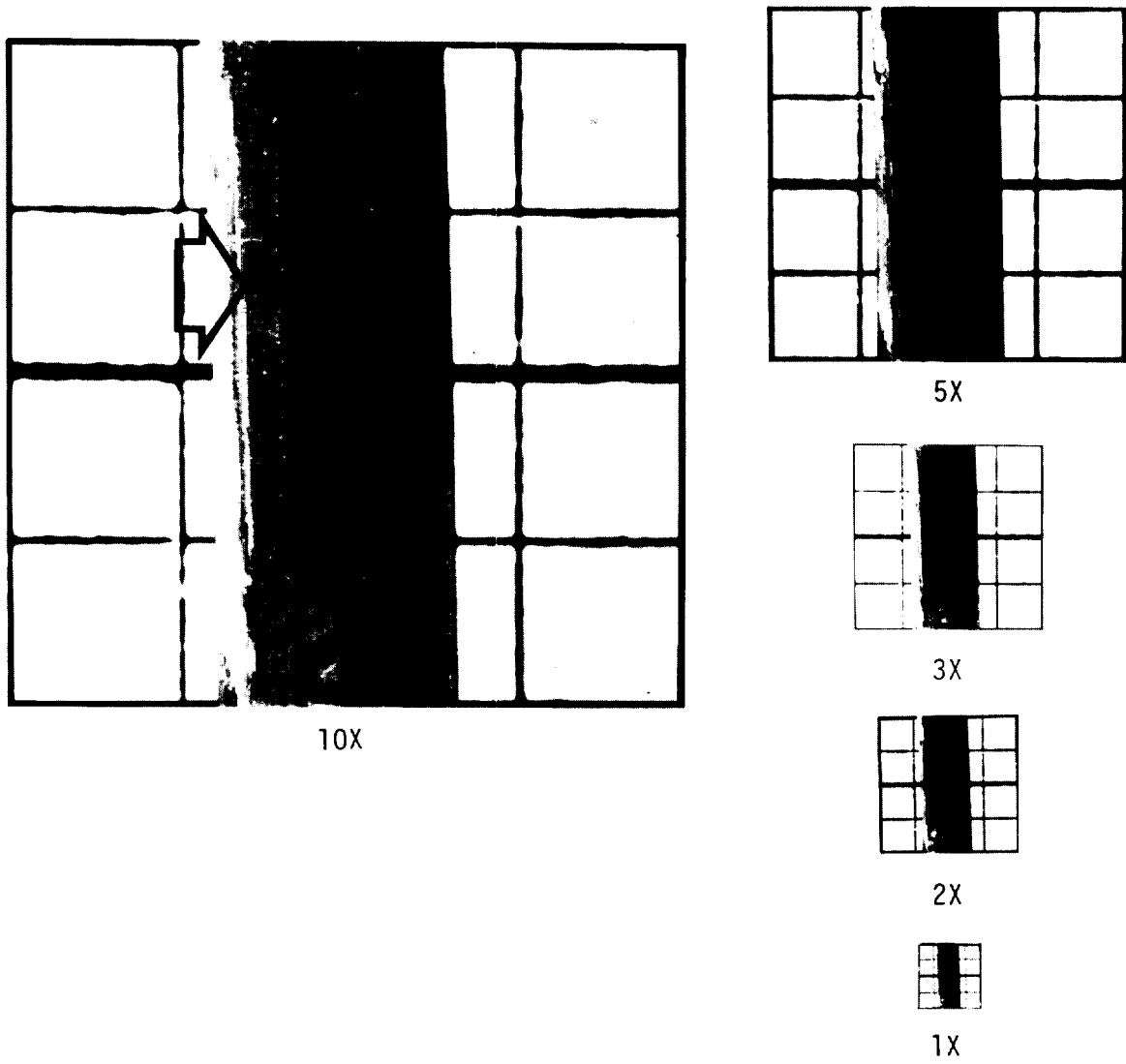

Figure 21 - Parting line indentation,  
acceptable,  
W = 0.139" (3.53 mm.)

MIL-STD-413C  
8 December 1980

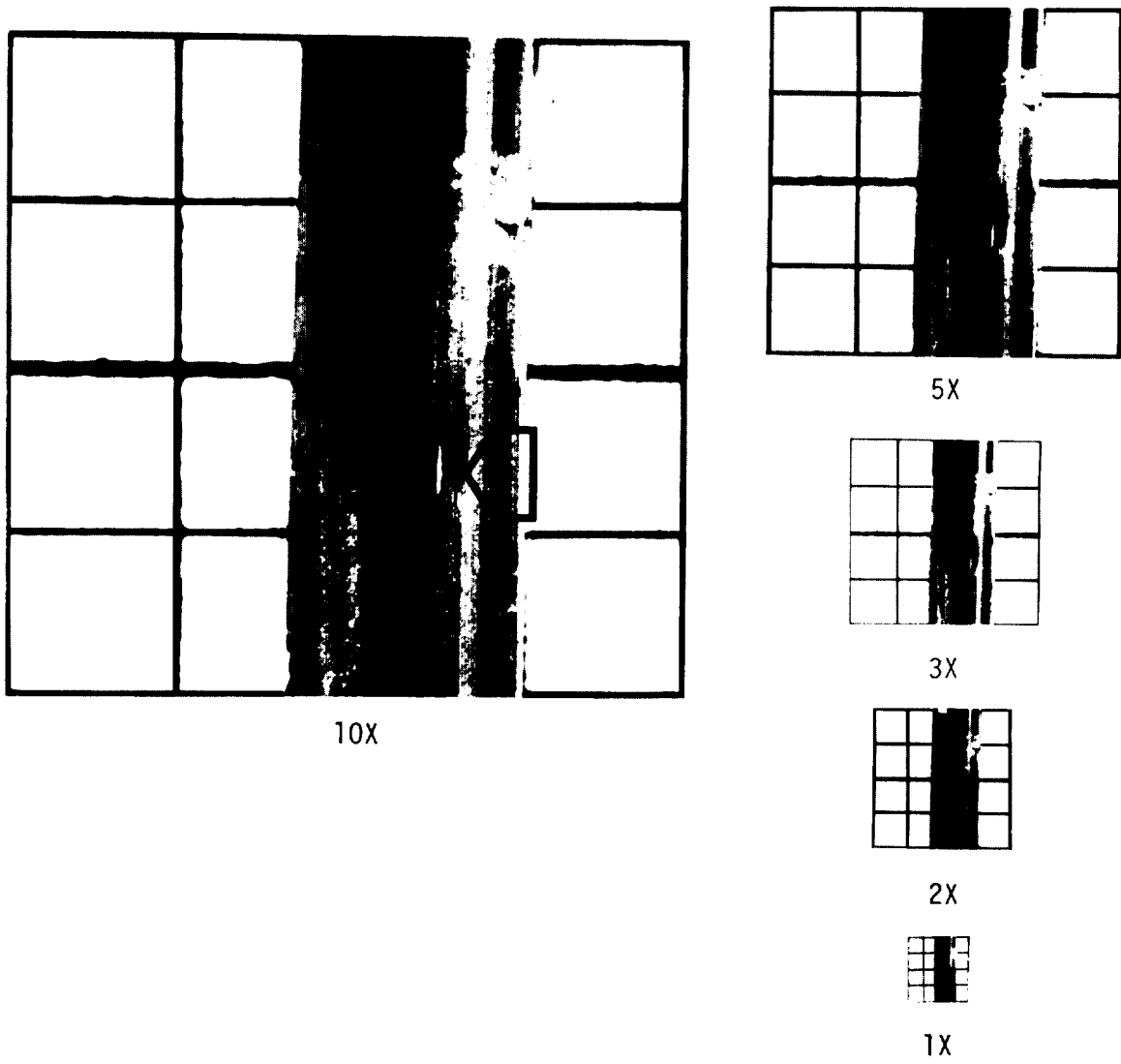

Figure 22 - Parting line indentation,  
unacceptable,  
W = 0.139" (3.53 mm.)

MIL-STD-413C  
8 December 1980

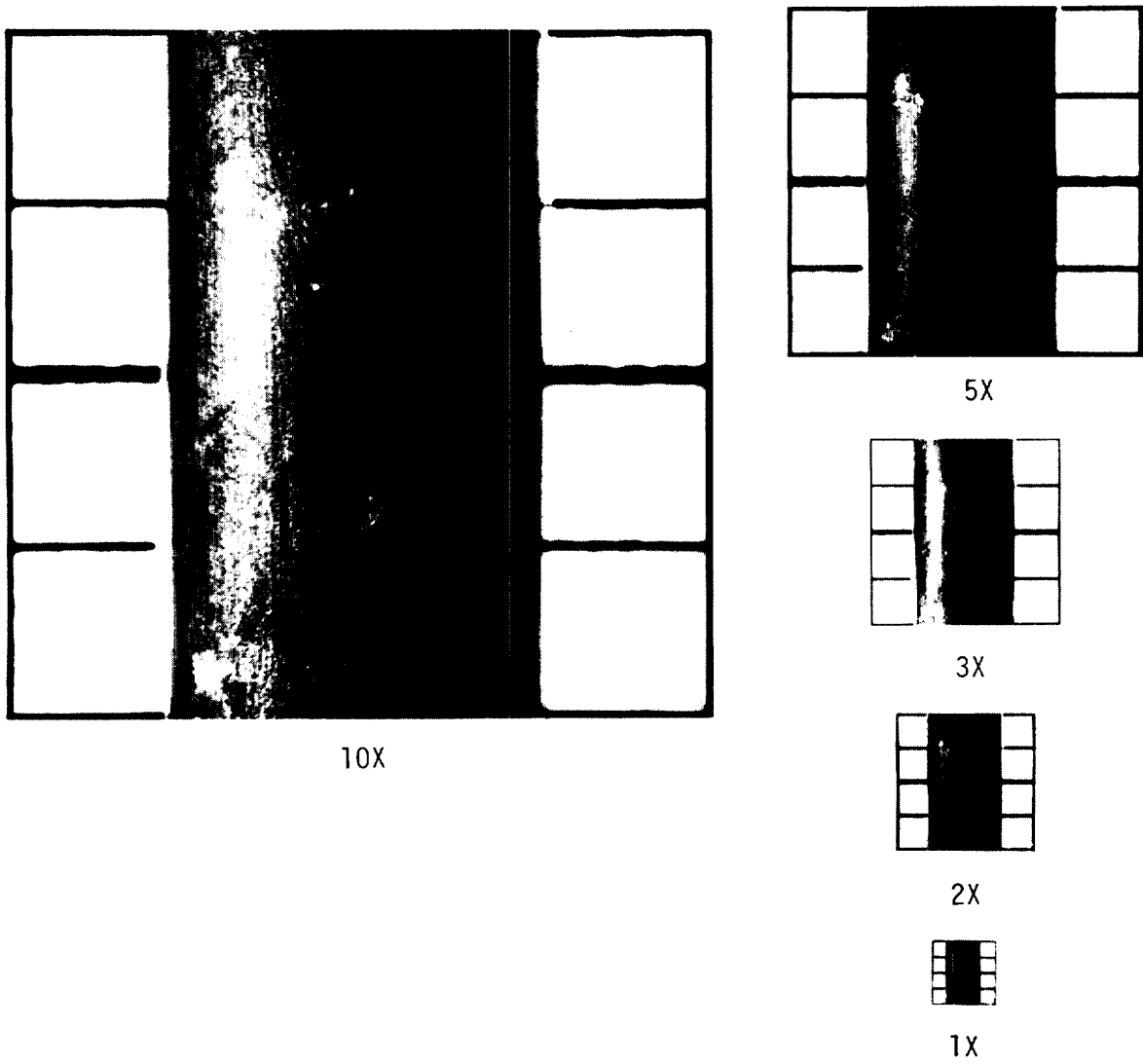

Figure 23 - Parting line indentation,  
acceptable,  
W = 0.210" (5.33 mm.)

MIL-STD-413C  
8 December 1980

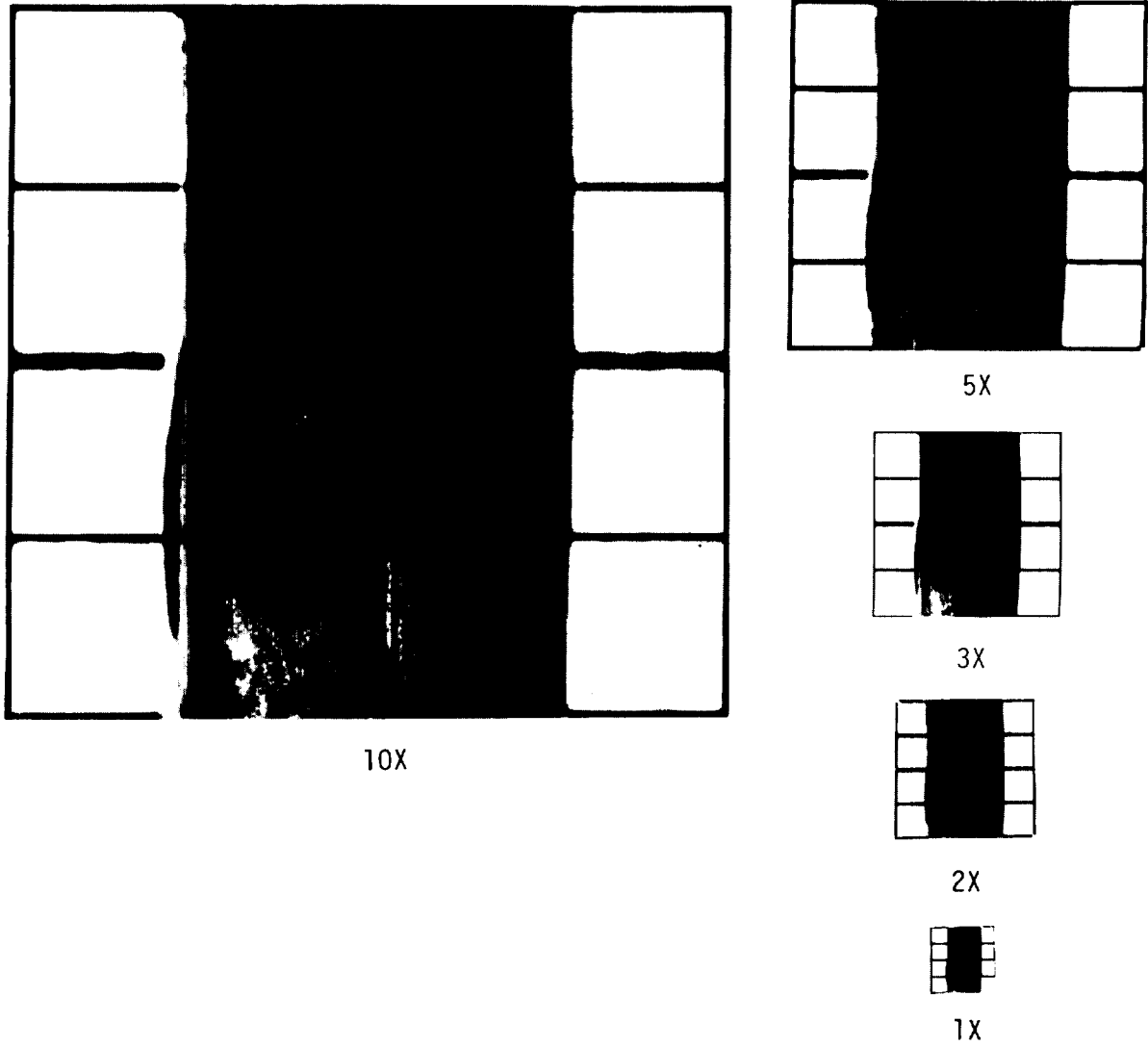

Figure 24 - Parting line indentation,  
unacceptable,  
W = 0.210" (5.33 mm.)

MIL-STD-413C  
8 December 1980

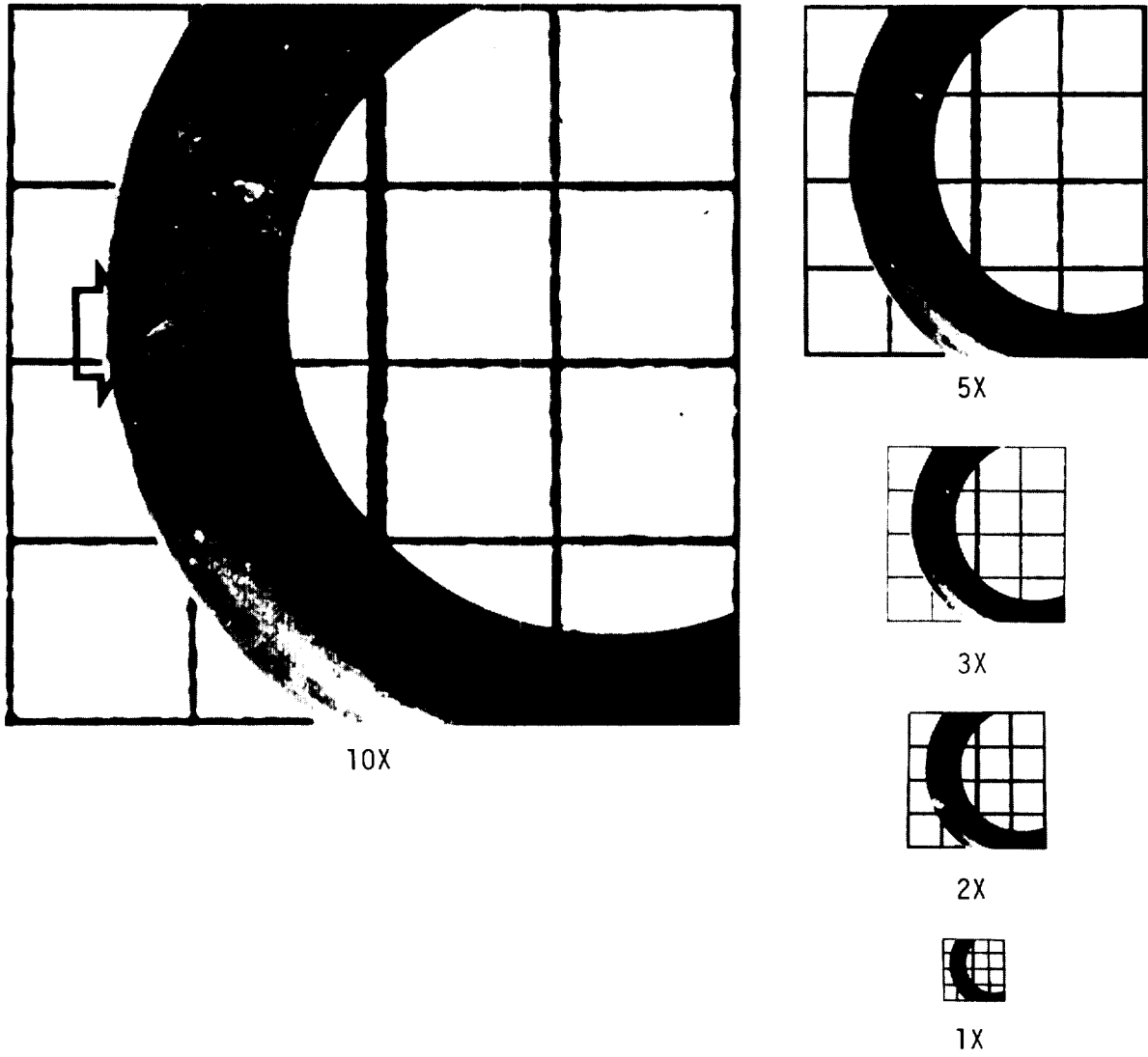

Figure 25 - Foreign material,  
acceptable,  
W = 0.103" (2.62 mm.)

MIL-STD-413C  
8 December 1980

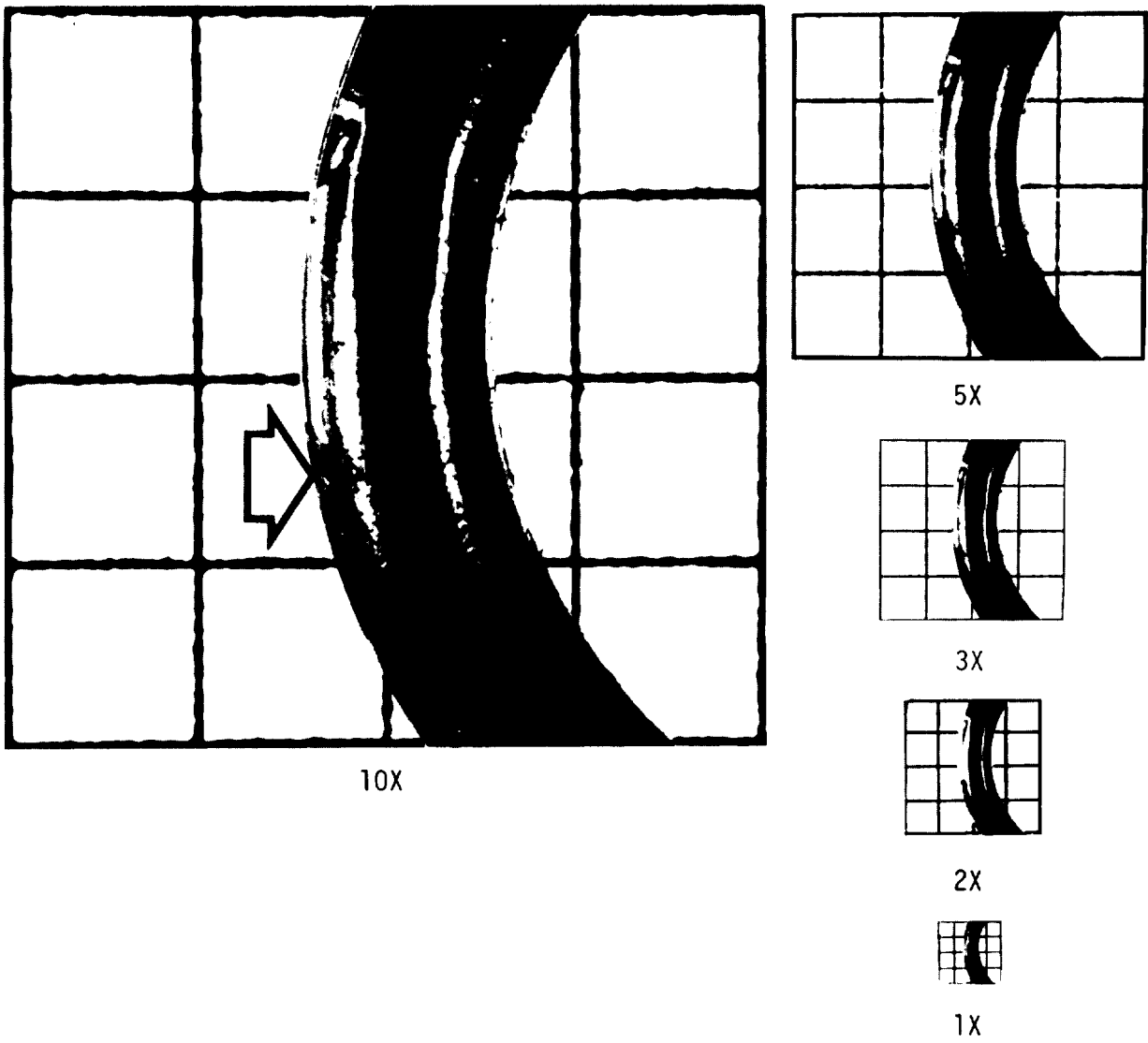

Figure 26 - Foreign material,  
unacceptable,  
W = 0.103" (2.62 mm.)

MIL-STD-413C  
8 December 1980

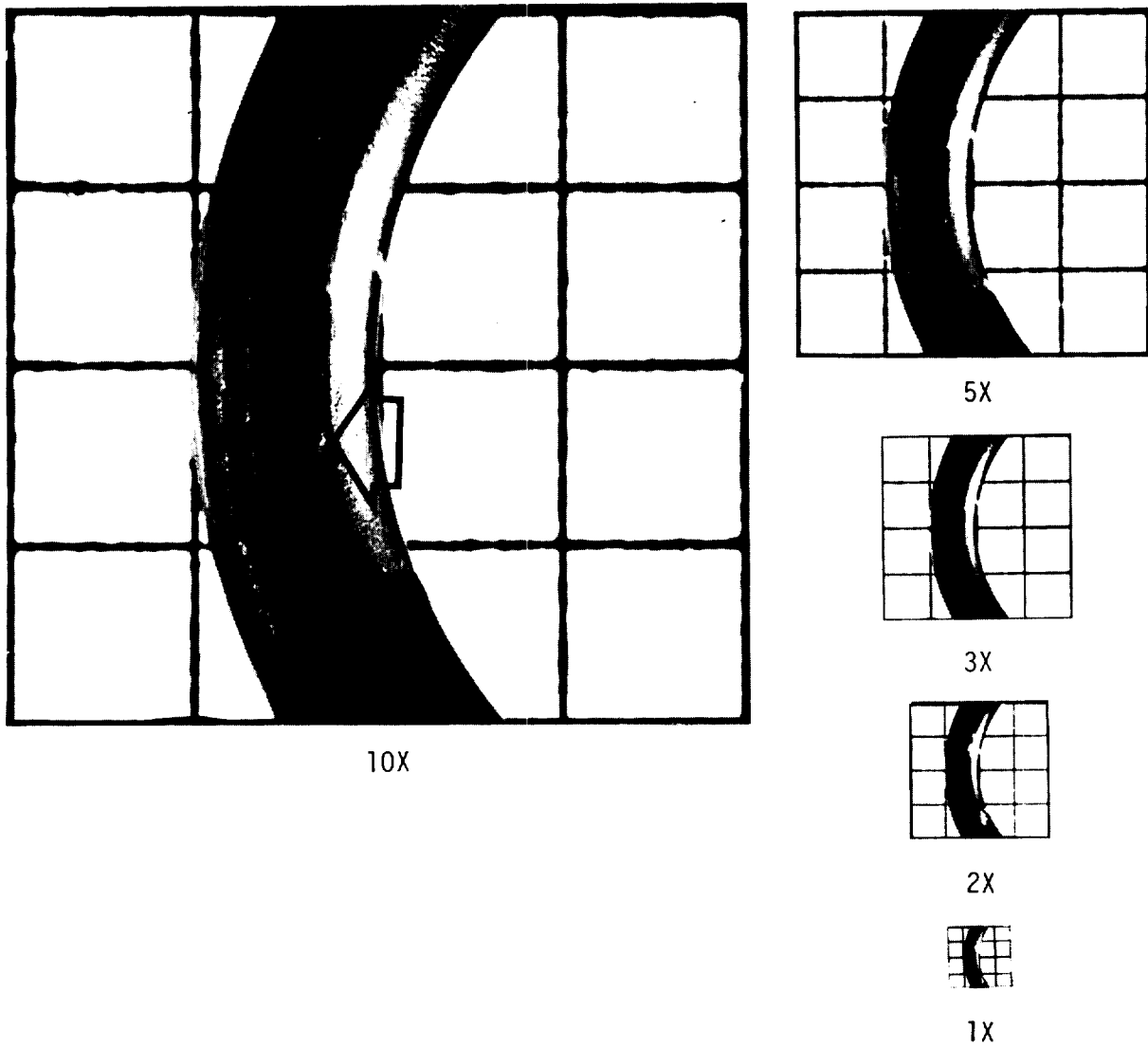

Figure 27 - Foreign material,  
acceptable,  
W = 0.103" (2.62 mm.)

MIL-STD-413C  
8 December 1980

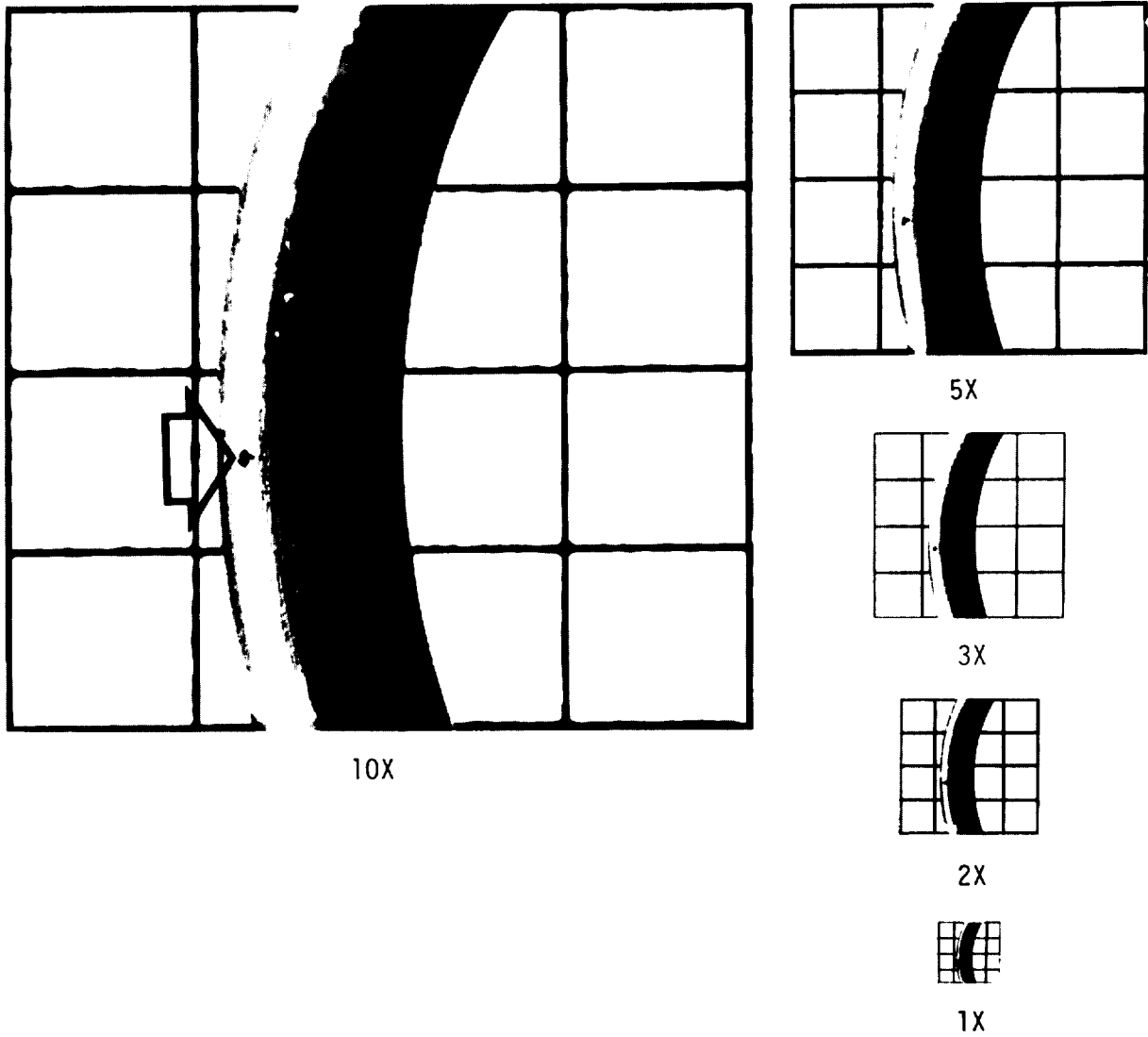

Figure 28 - Foreign material,  
unacceptable,  
W = 0.103" (2.62 mm.)

MIL-STD-413C  
8 December 1980

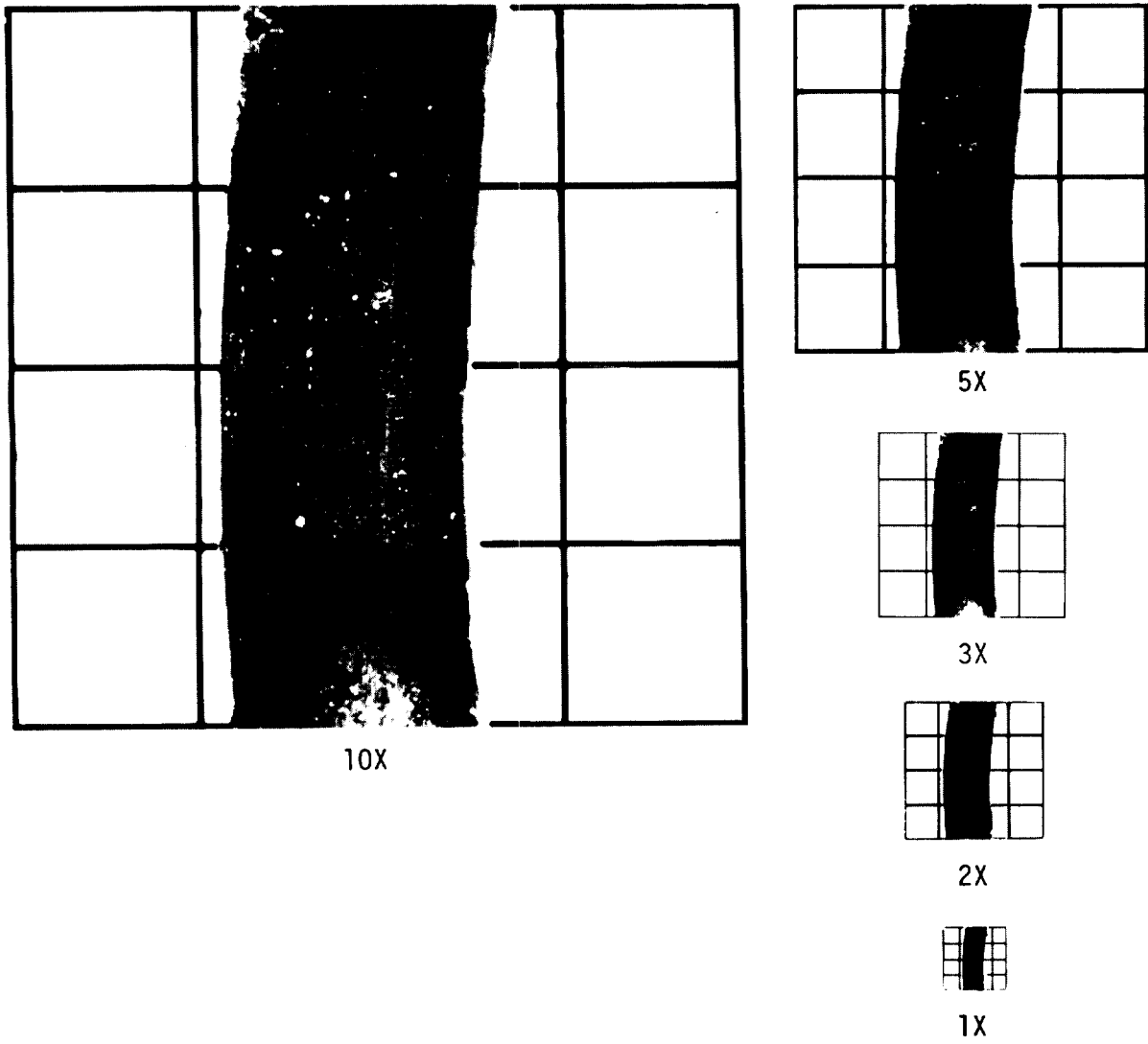

Figure 29 - Foreign material,  
acceptable,  
W = 0.139" (3.53 mm.)

MIL-STD-413C  
8 December 1980

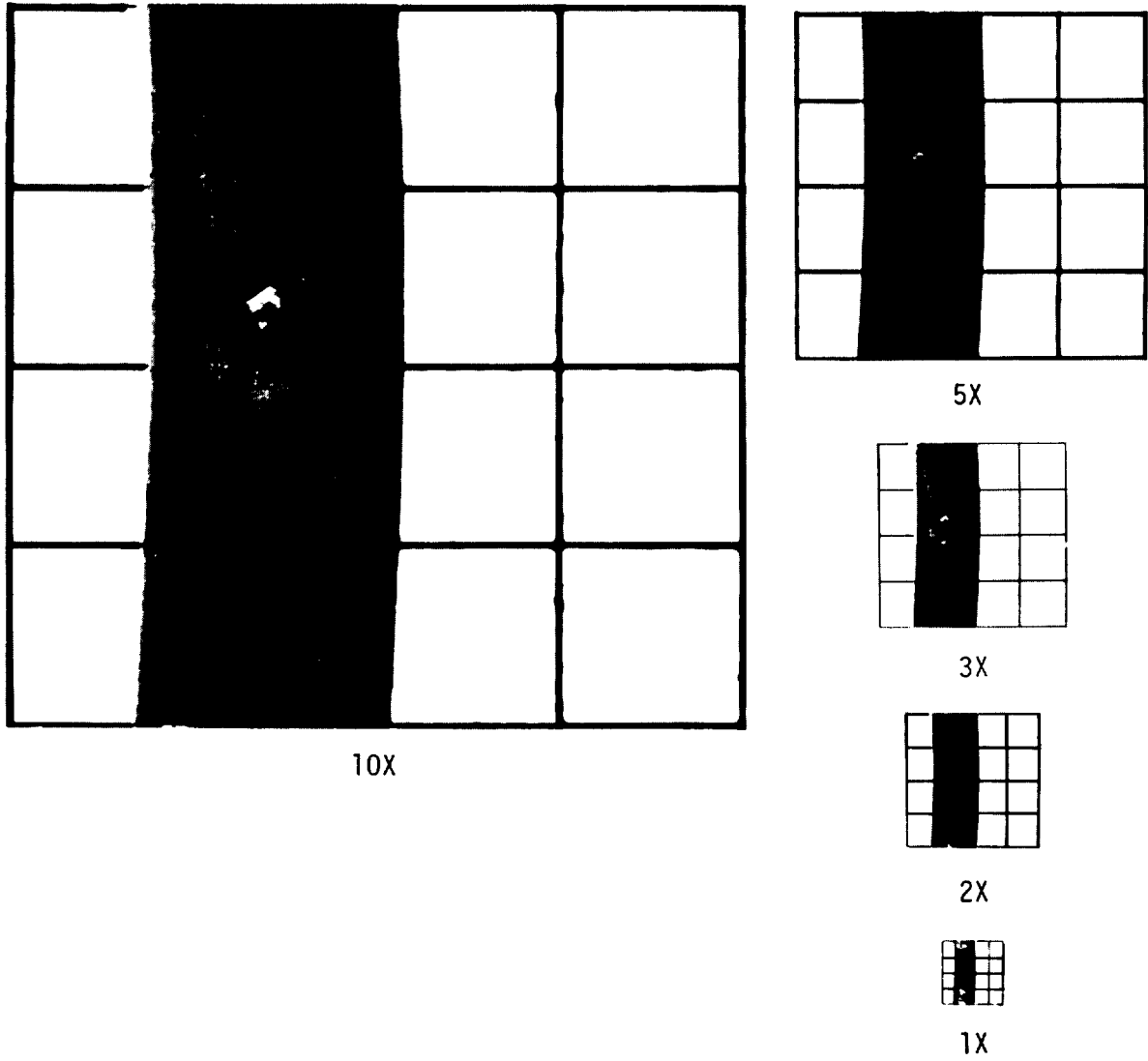

Figure 30 - Foreign material,  
unacceptable,  
W = 0.139" (3.53 mm.)

MIL-STD-413C  
8 December 1980

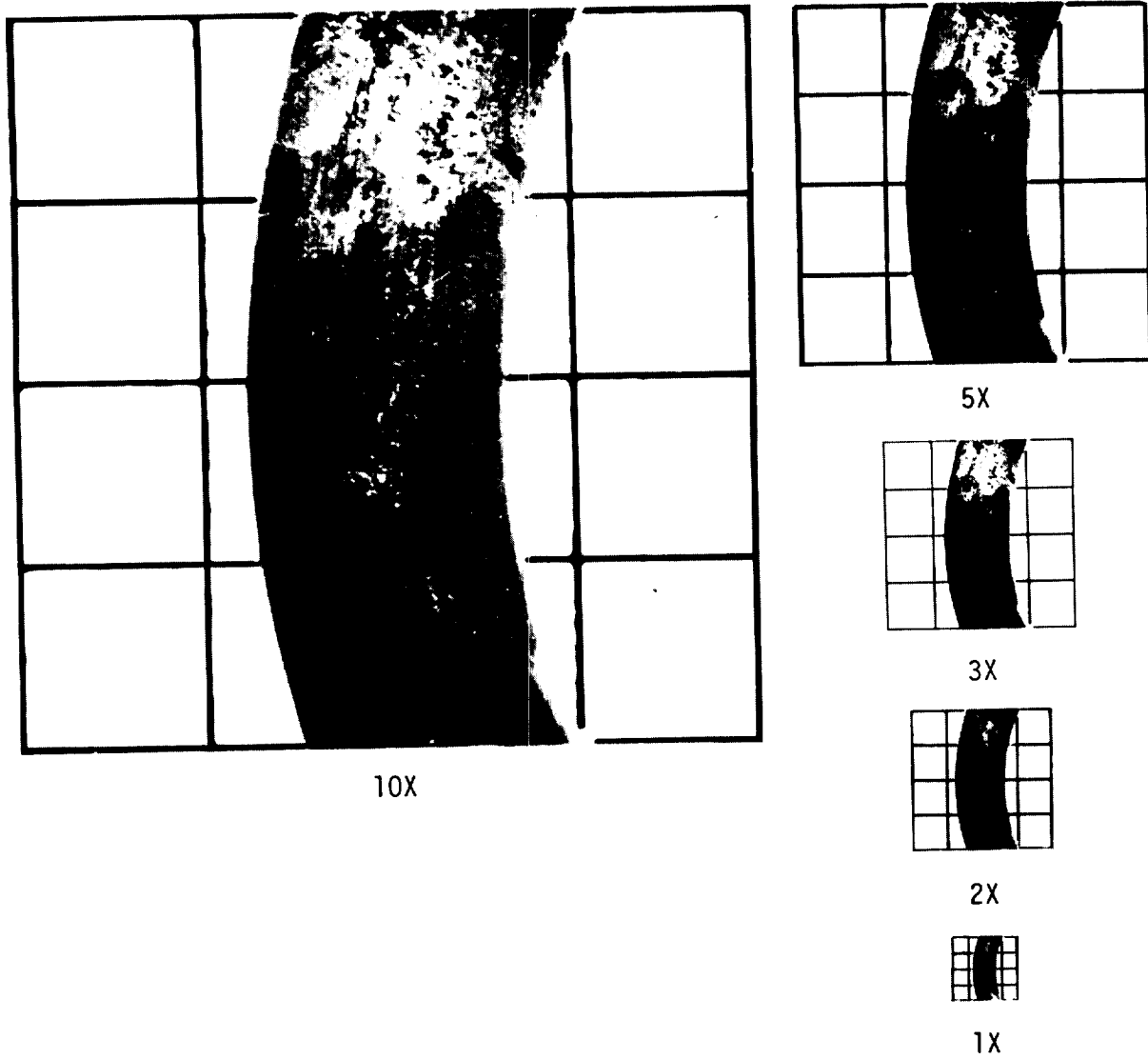

Figure 31 - Foreign material,  
acceptable,  
W = 0.139" (3.53 mm.)

MIL-STD-413C  
8 December 1980

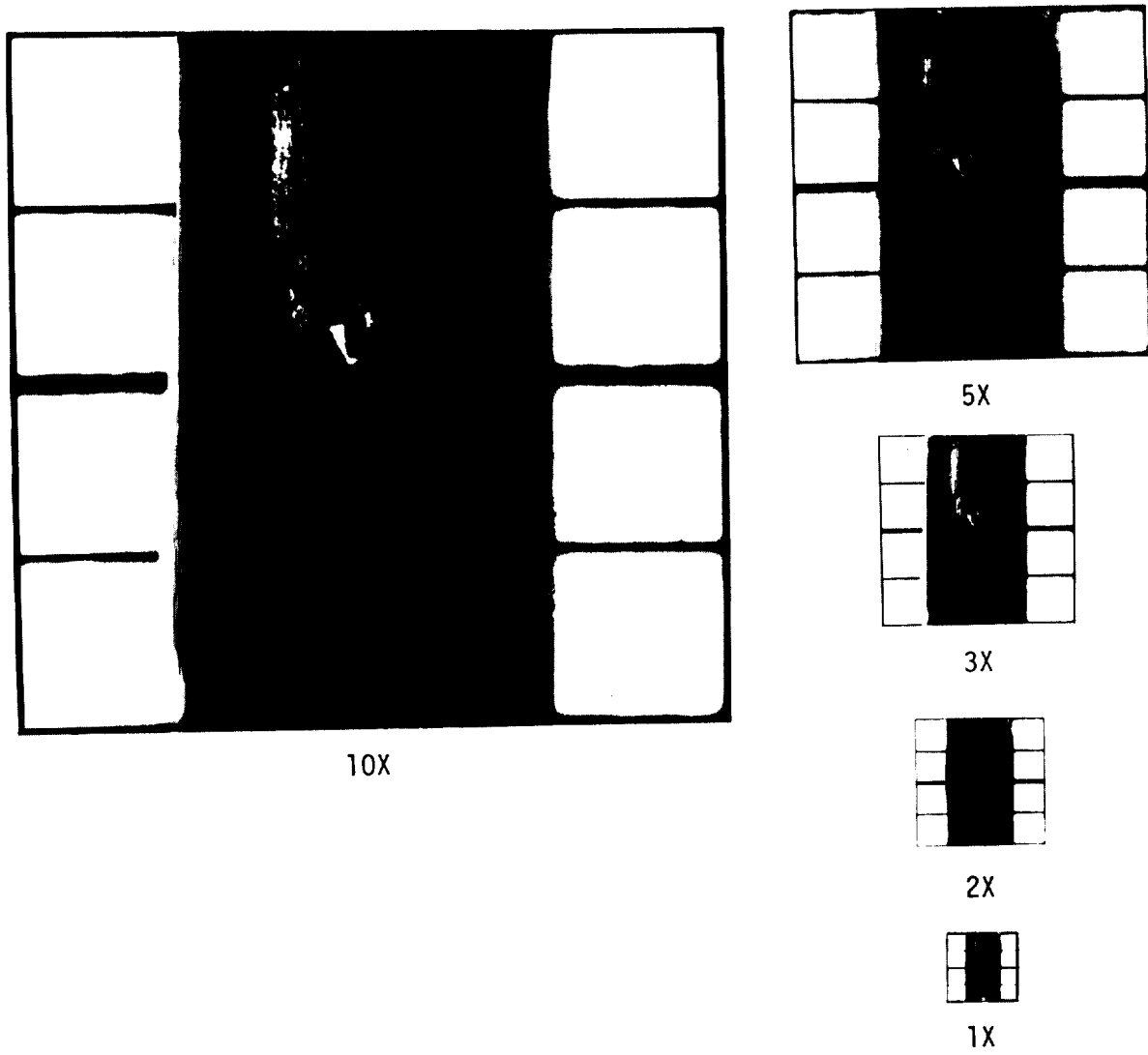
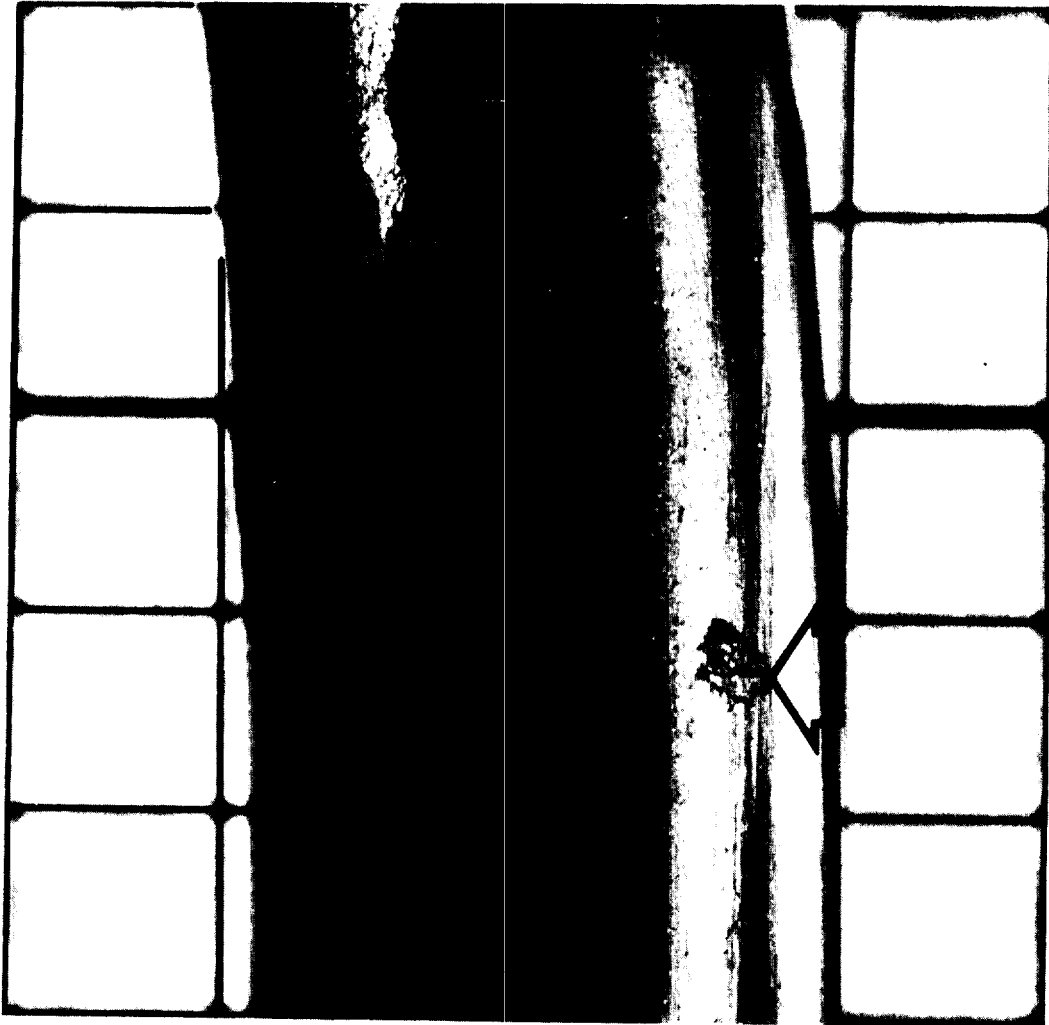
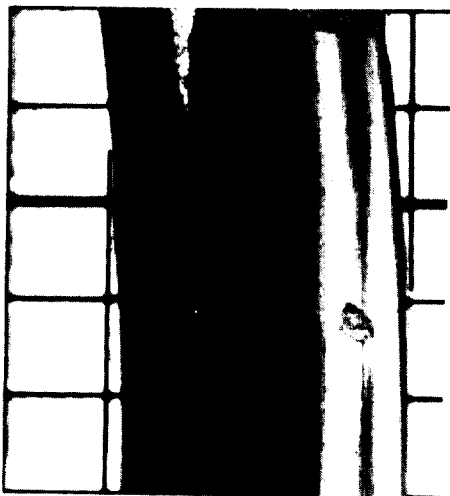

Figure 32 - Foreign material,  
unacceptable,  
W = 0.210" (5.33 mm.)

MIL-STD-413C  
8 December 1980



10X



5X

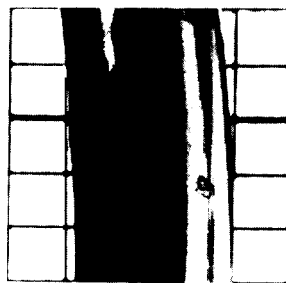

3X

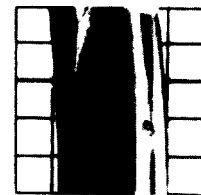

2X

Figure 33 - Foreign material,  
unacceptable,  
W = 0.275" (6.98 mm.)

MIL-STD-413C  
8 December 1980

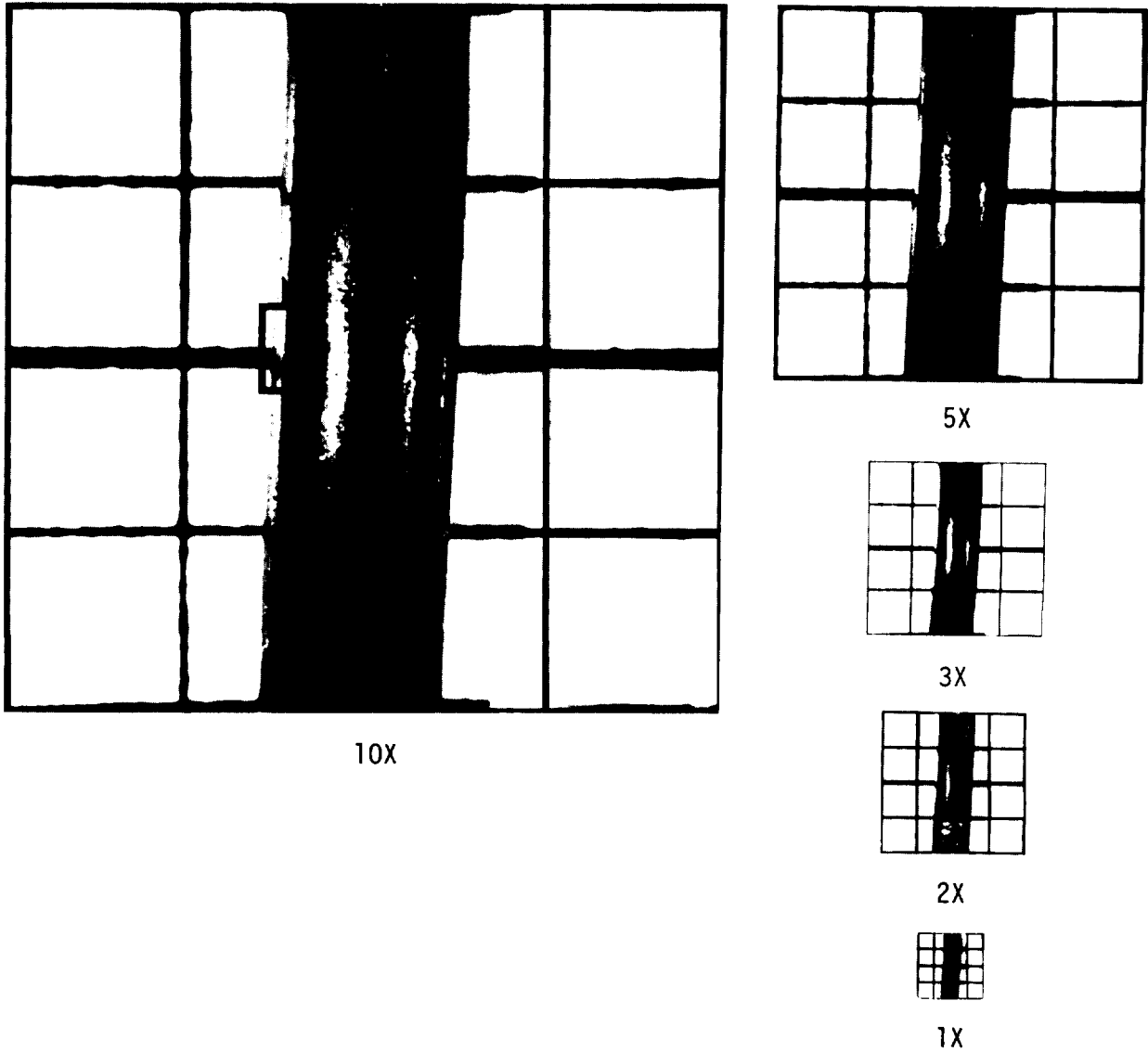

Figure 34 - Excessive trimming,  
acceptable,  
W = 0.103" (2.62 mm.)

MIL-STD-413C  
8 December 1980

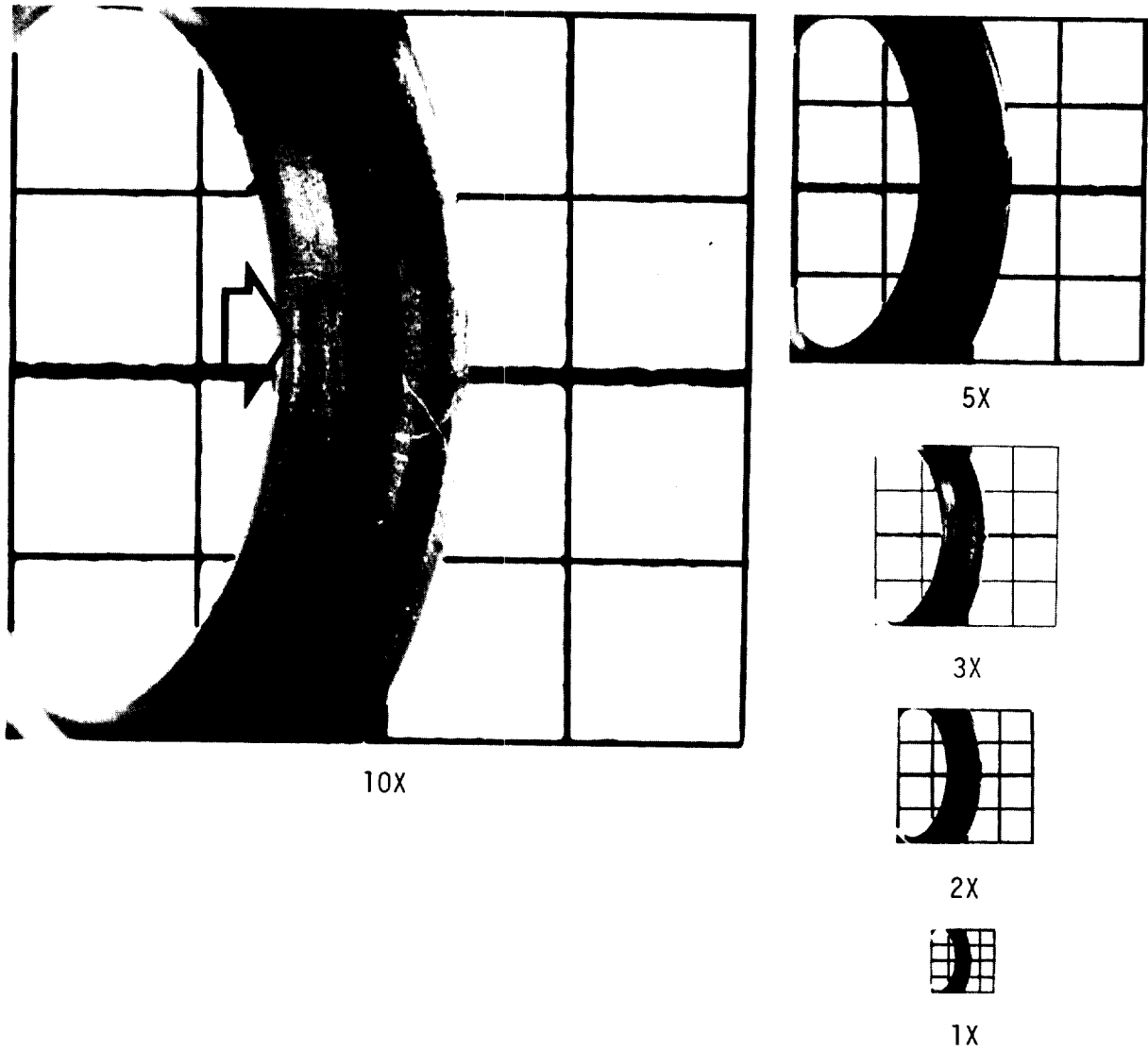

Figure 35 - Excessive trimming,  
unacceptable,  
W = 0.103" (2.62 mm.)

MIL-STD-413C  
8 December 1980

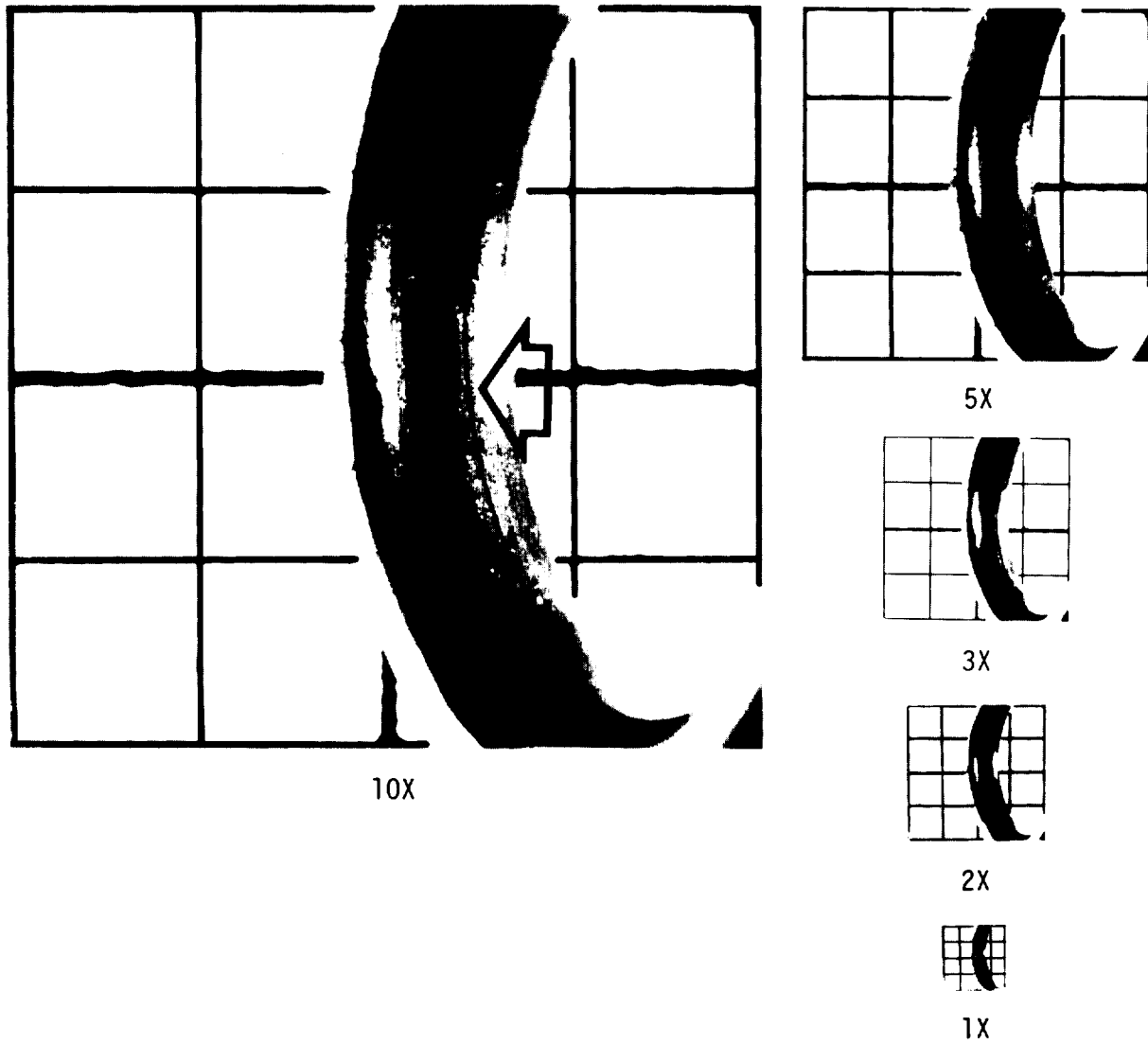

Figure 36 - Excessive trimming,  
acceptable,  
W = 0.103" (2.62 mm.)

MIL-STD-413C  
8 December 1980

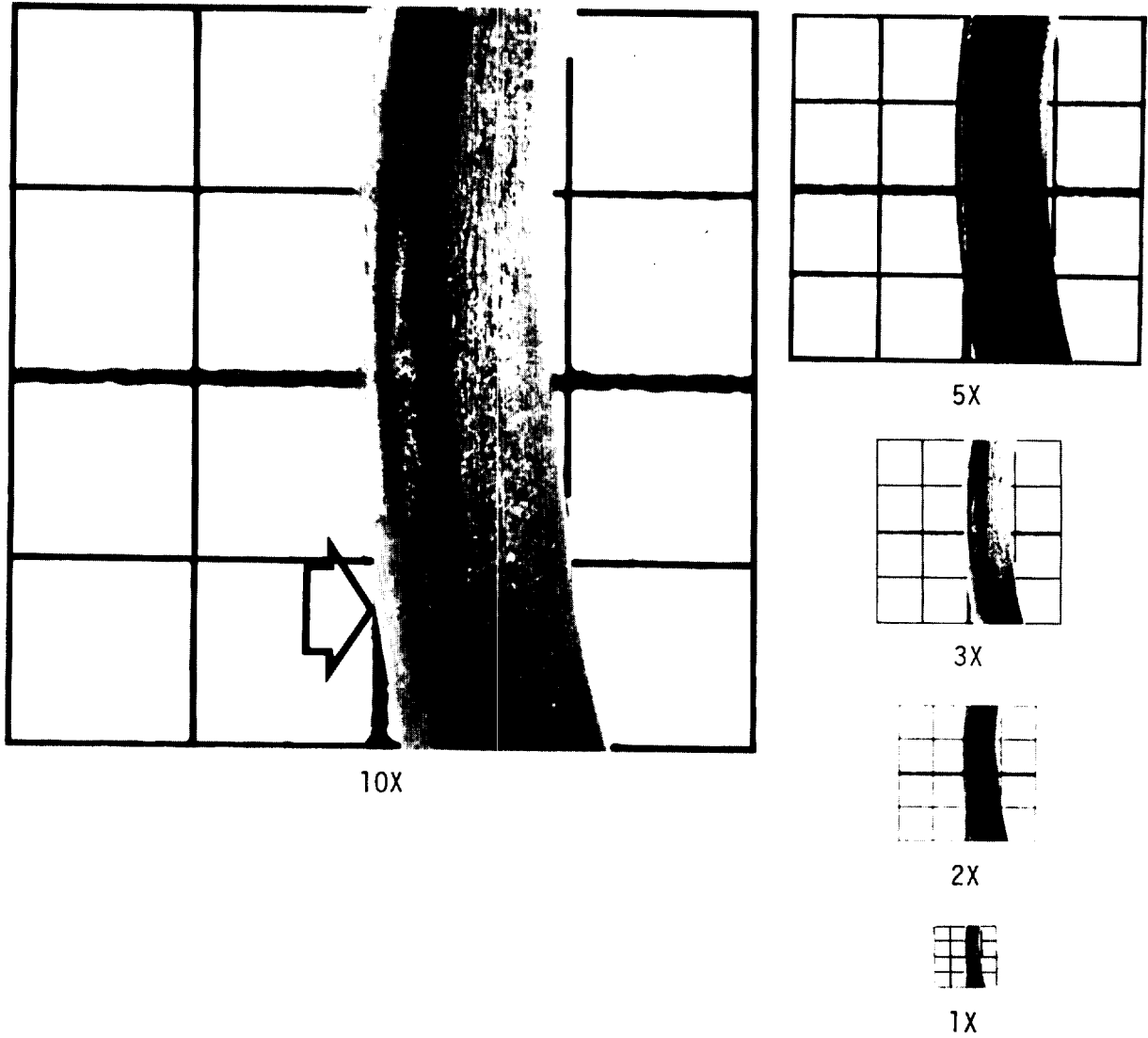

Figure 37 - Excessive trimming  
unacceptable,  
W = 0.103" (2.62 mm.)

MIL-STD-413C  
8 December 1980

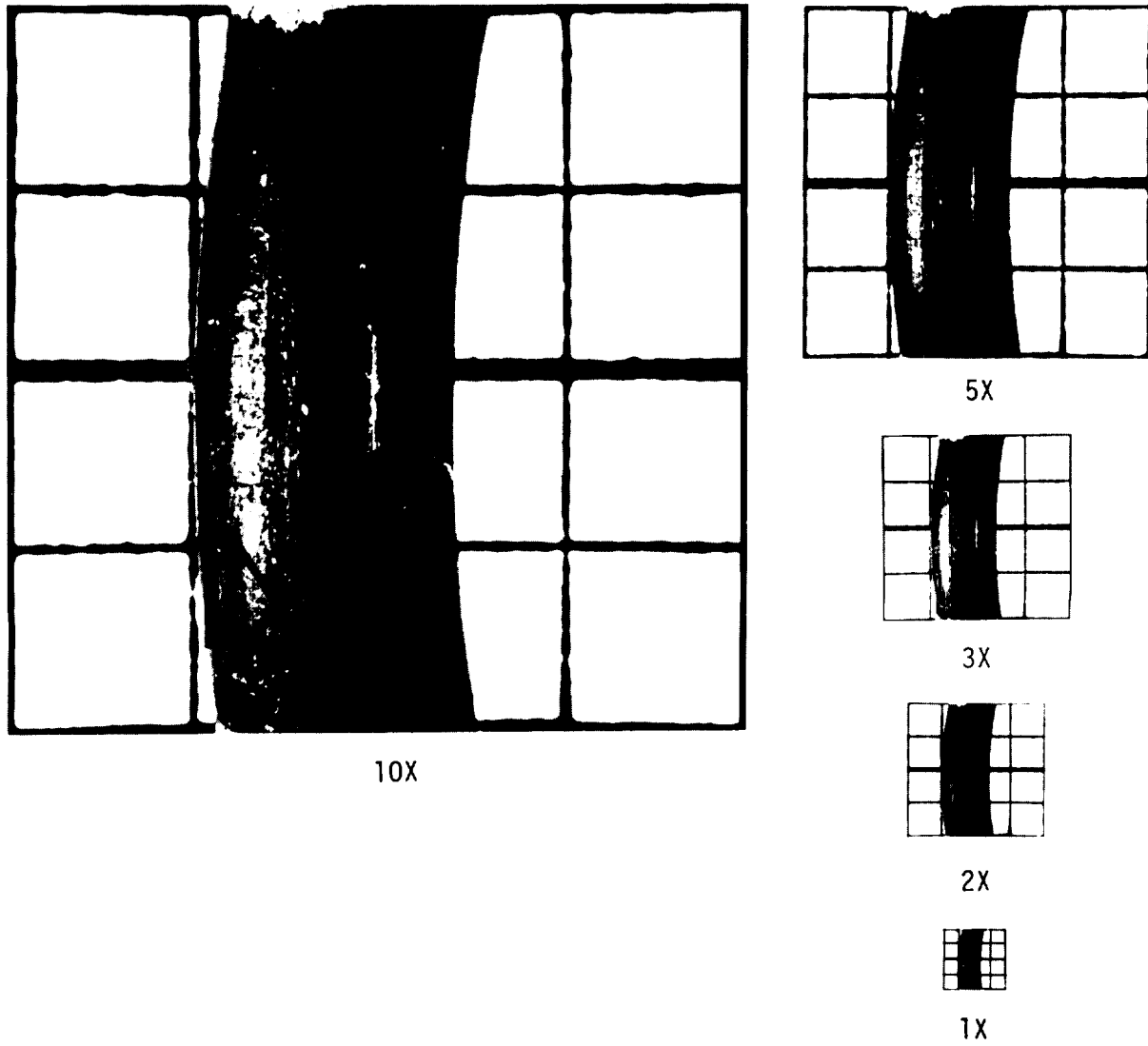

Figure 38 - Excessive trimming,  
acceptable,  
W = 0.139" (3.53 mm.)

MIL-STD-413C  
8 December 1980

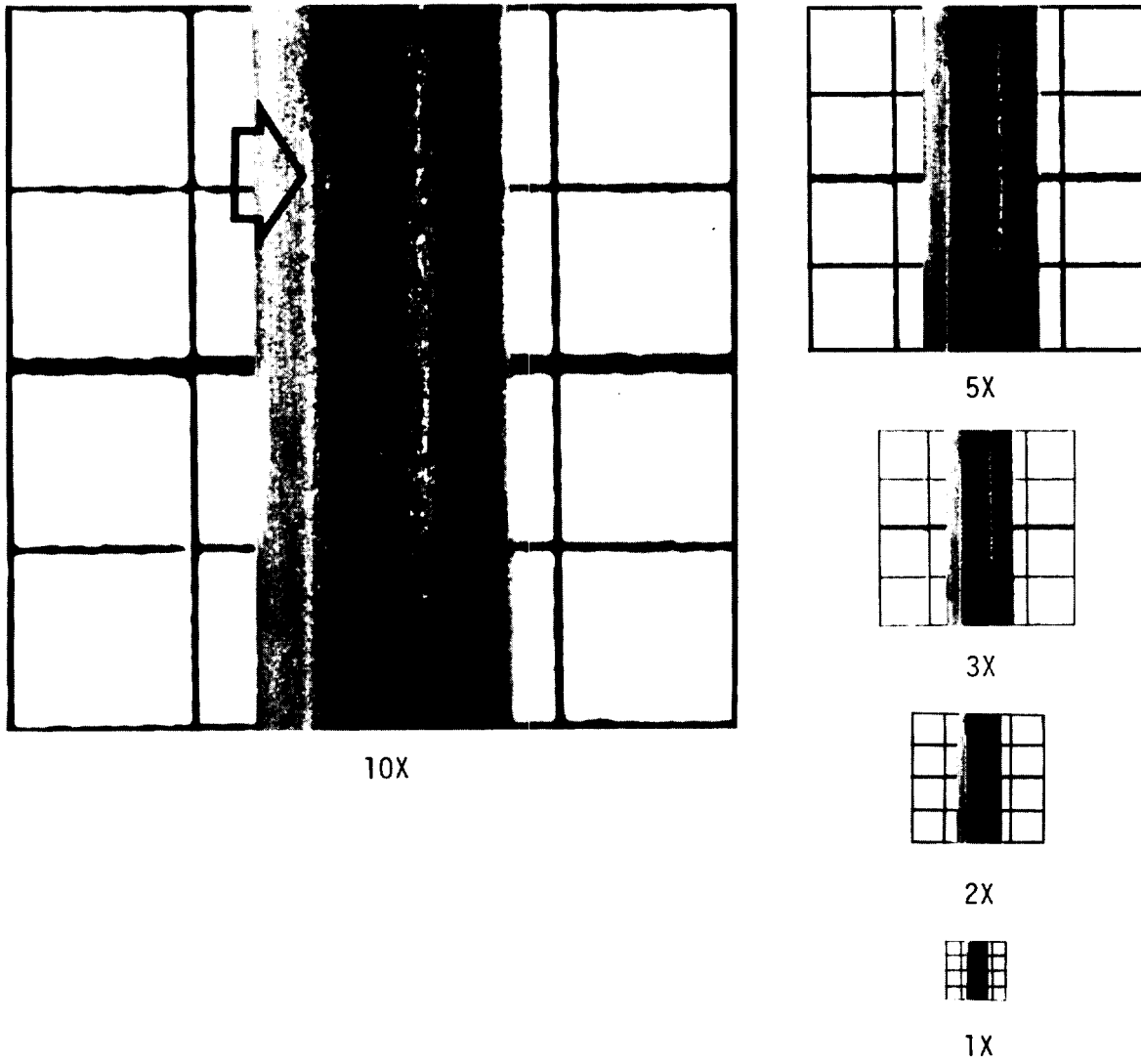

Figure 39 - Excessive trimming,  
unacceptable,  
W = 0.139" (3.53 mm.)

MIL-STD-413C  
8 December 1980

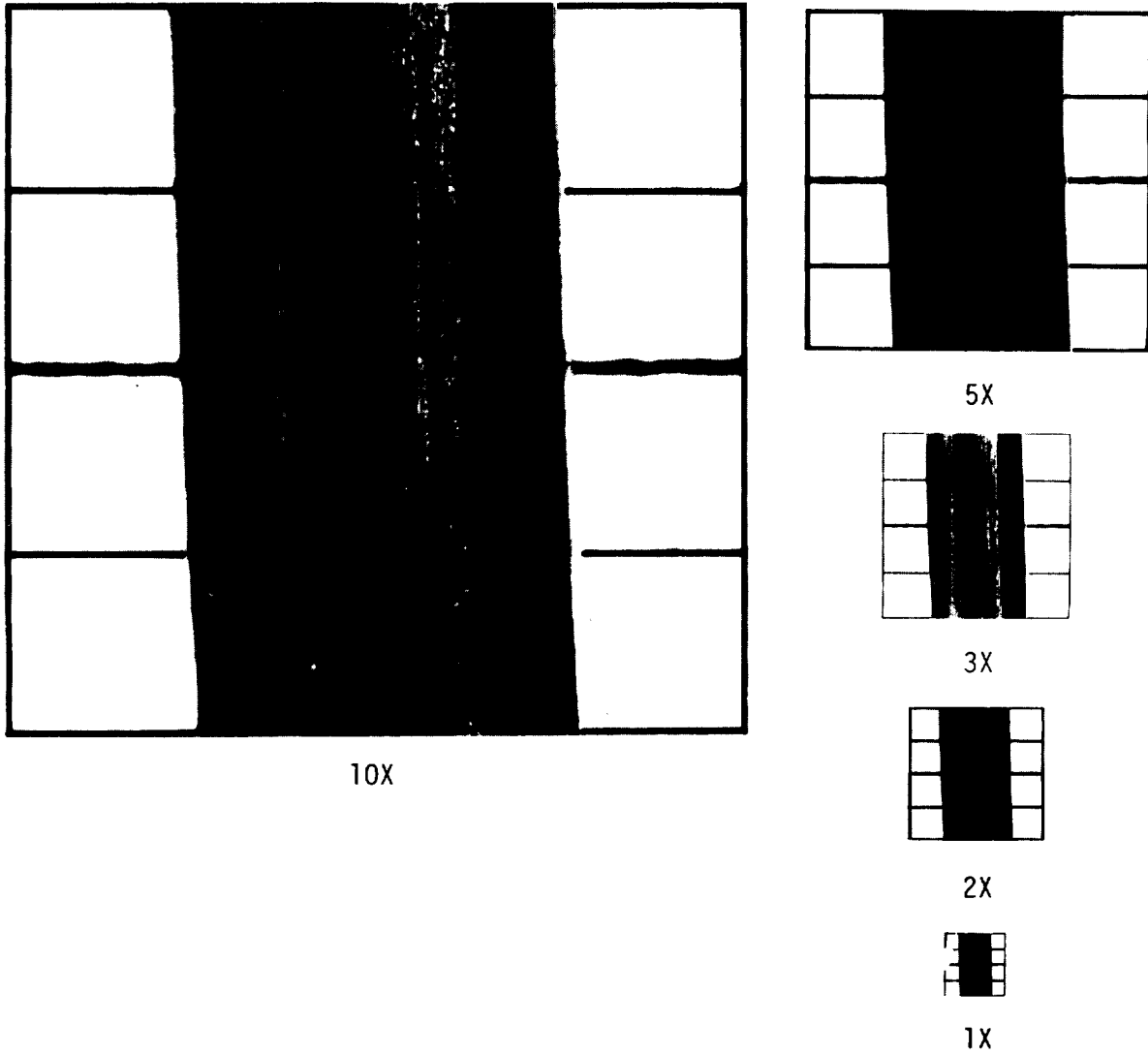

Figure 40 - Excessive trimming,  
acceptable,  
W = 0.210" (5.33 mm.)

MIL-STD-413C  
8 December 1980

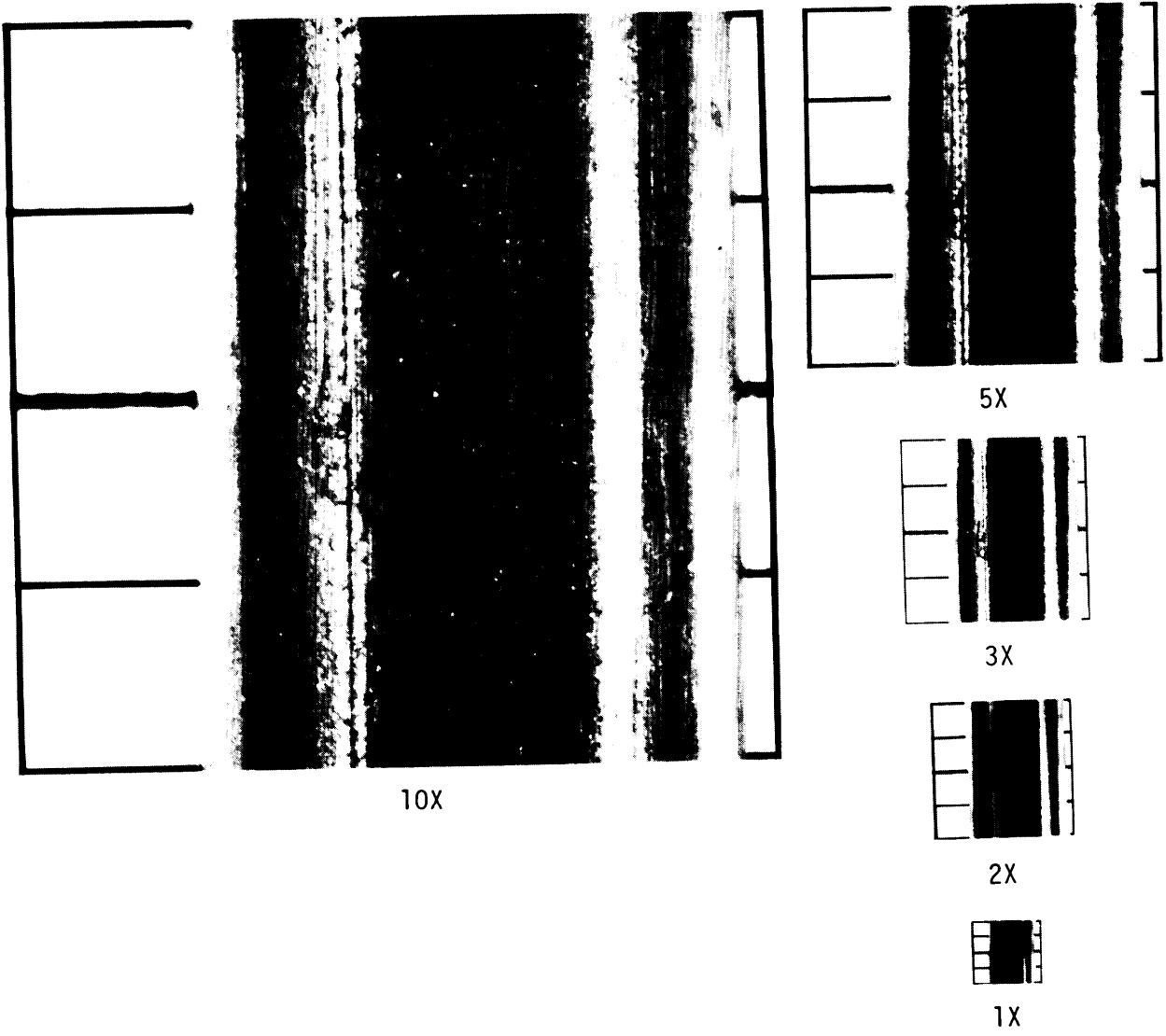

Figure 41 - Excessive trimming,  
unacceptable,  
w = 0.275" (6.98 mm.)

MIL-STD-413C  
8 December 1980

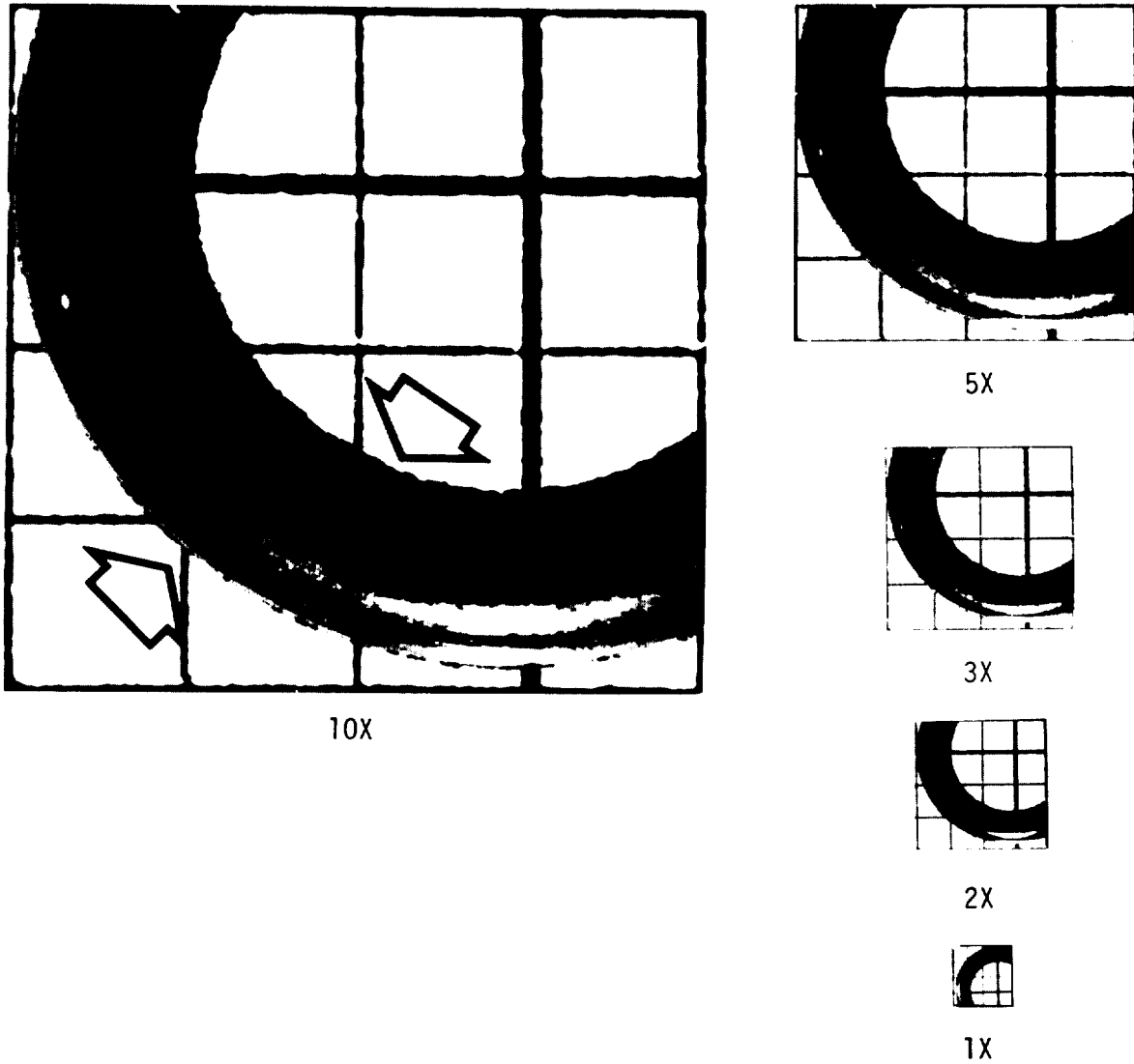

Figure 42 - Excessive flash,  
unacceptable,  
W = 0.103" (2.62 mm.)

MIL-STD-413c  
8 December 1980

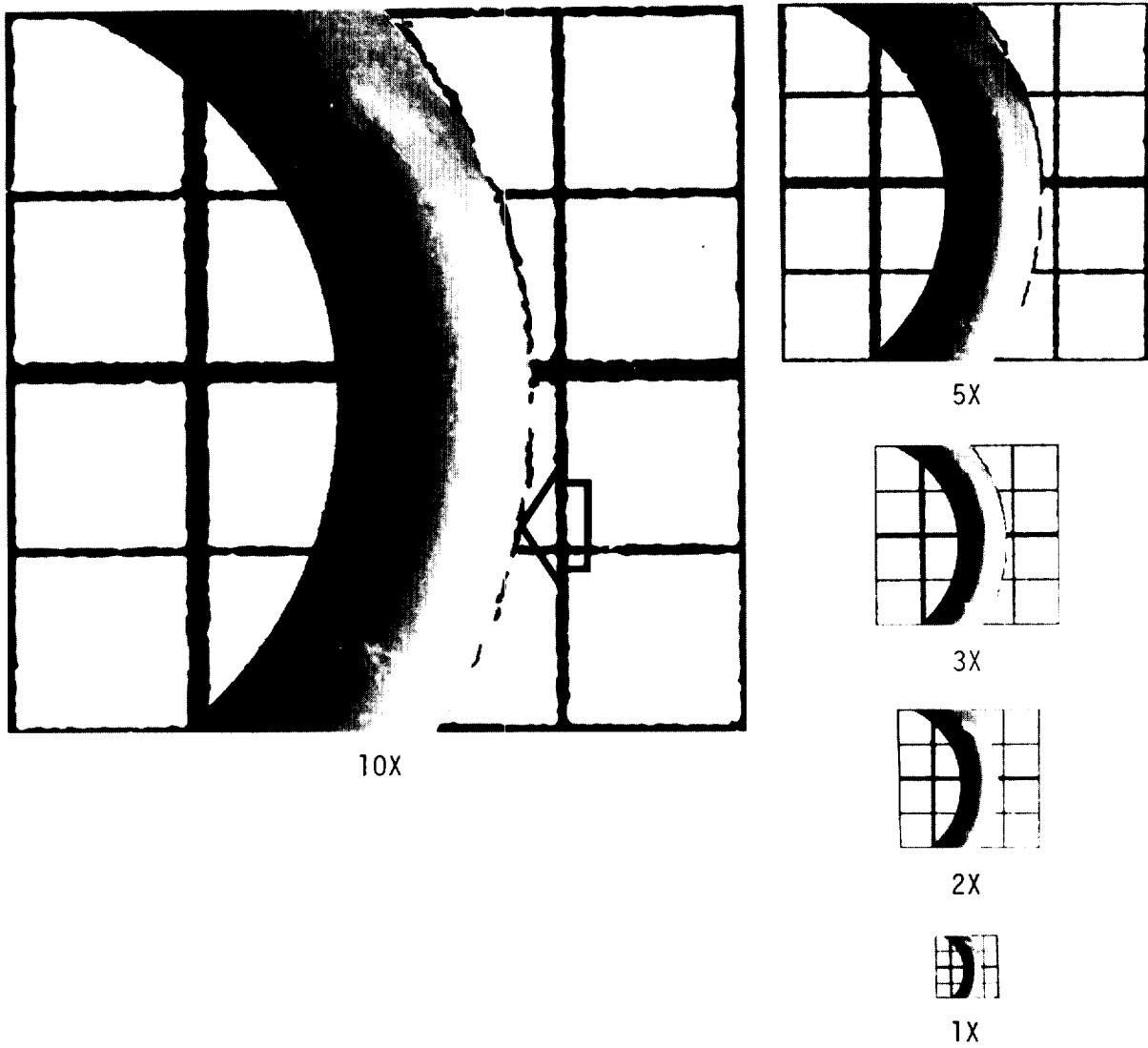

Figure 43 - Excessive flash,  
unacceptable,  
W = 0.103" (2.62 mm.)

MIL-STD-413C  
8 December 1980

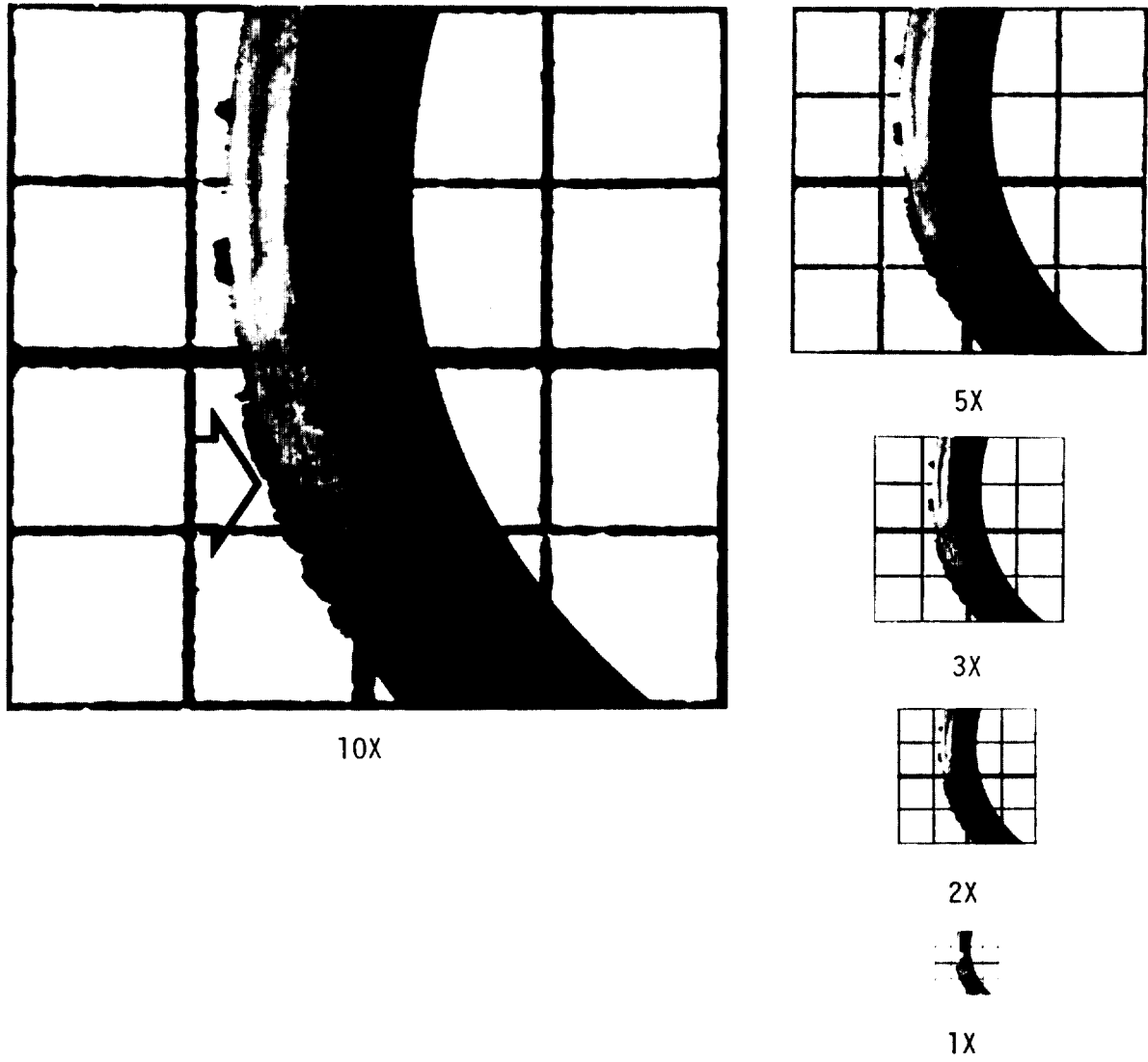

Figure 44 - Excessive flash,  
unacceptable,  
W = 0.103" (2.62 mm.)

MIL-STD-413C  
8 December 1980

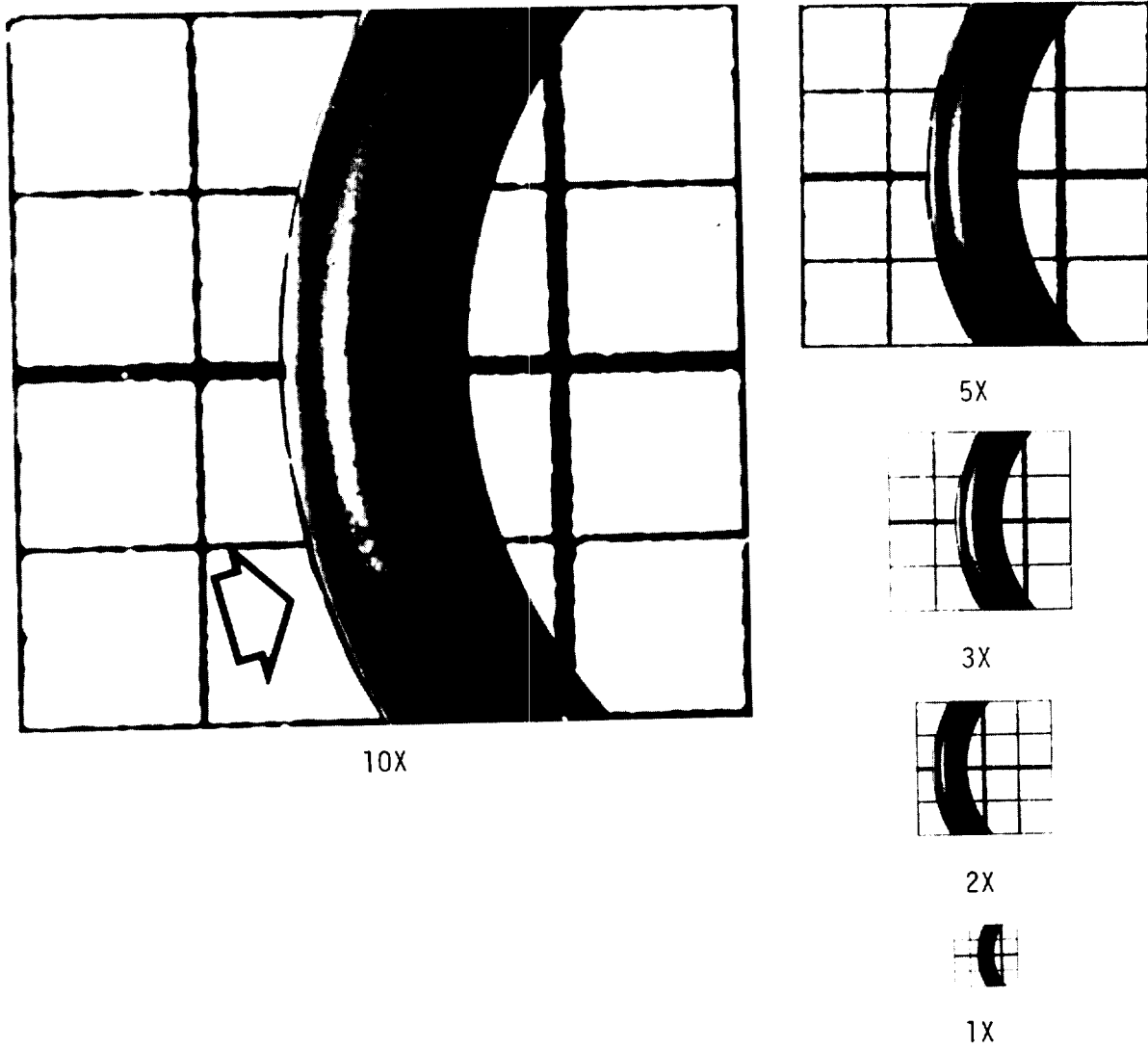

Figure 45 - Excessive flash,  
acceptable,  
W = 0.103" (2.62 mm.)

MIL-STD-413C  
8 December 1980

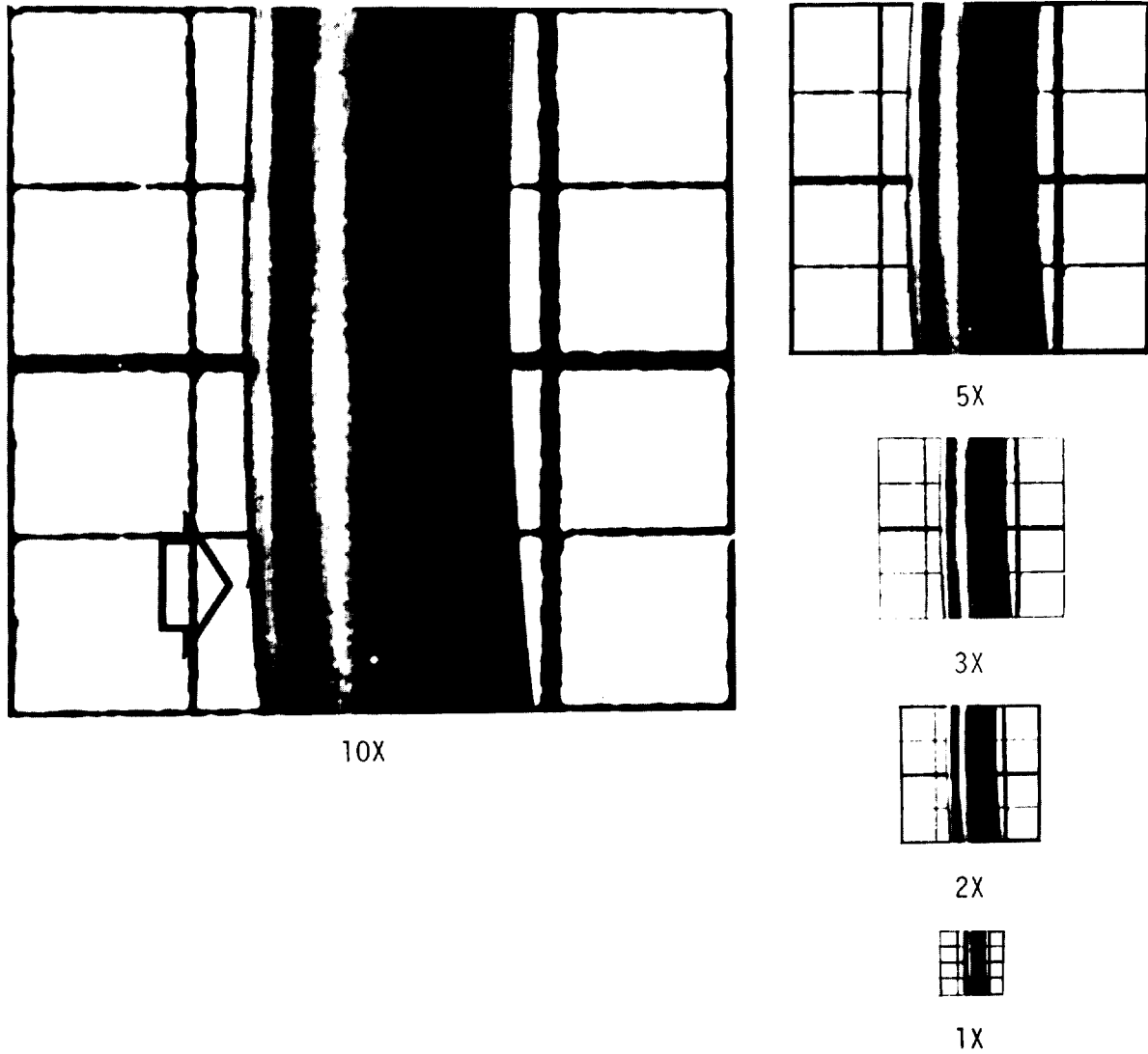

Figure 46 - Excessive flash,  
acceptable,  
W = 0.139" (3.53 mm.)

MIL-STD-413C  
8 December 1980

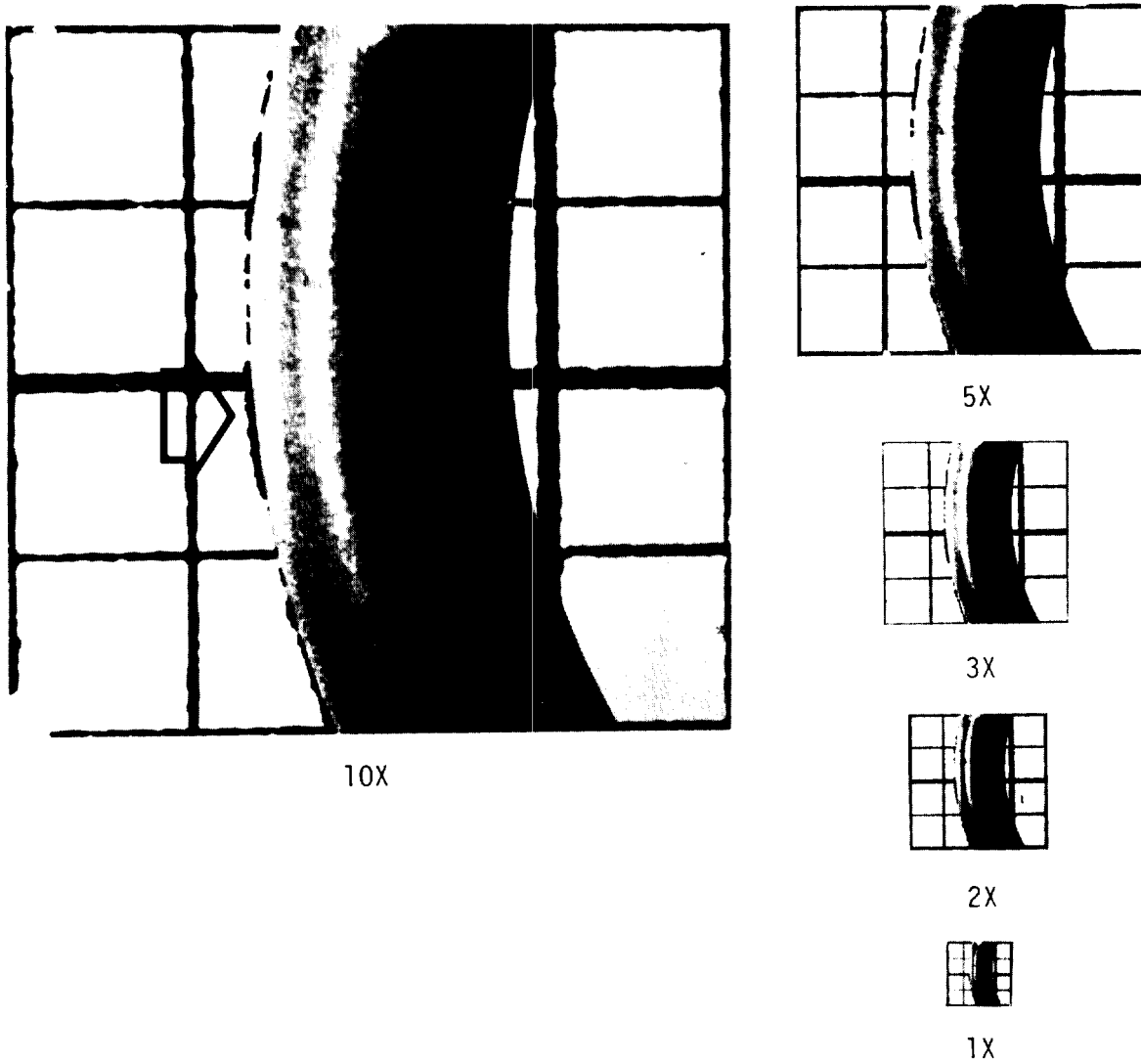
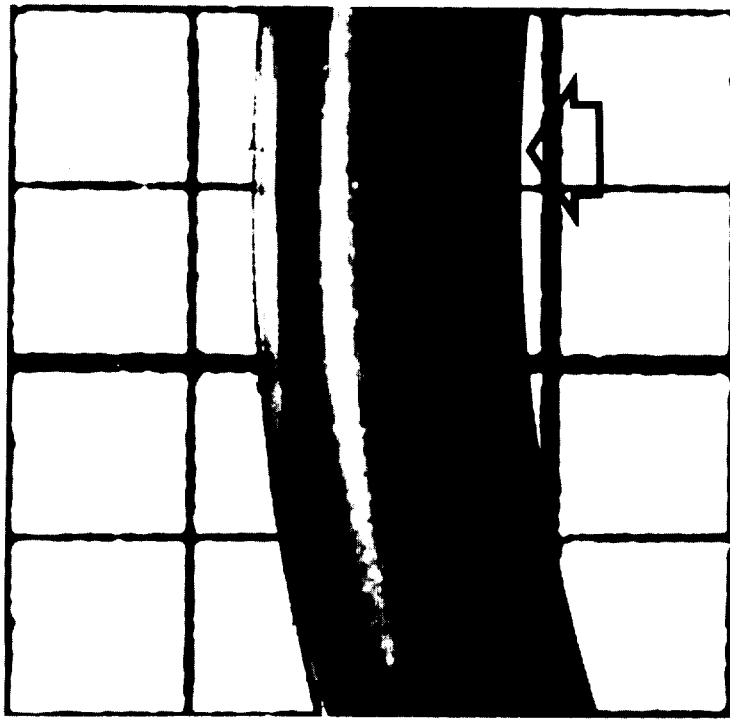
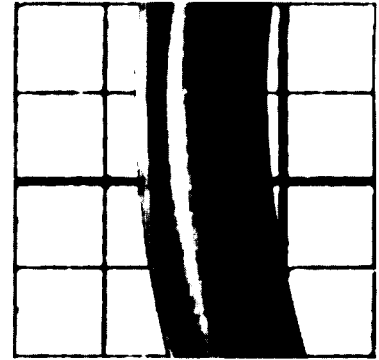

Figure 47 - Excessive flash,  
unacceptable,  
W = 0.139" (3.53 mm.)

MIL-STD-413C  
8 December 1980



10X



5X

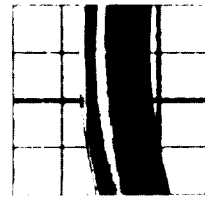

3X

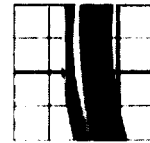

2X



1X

Figure 48 - Excessive flash,  
acceptable,  
W = 0.139" (3.53 mm.)

MIL-STD-413C  
8 December 1980

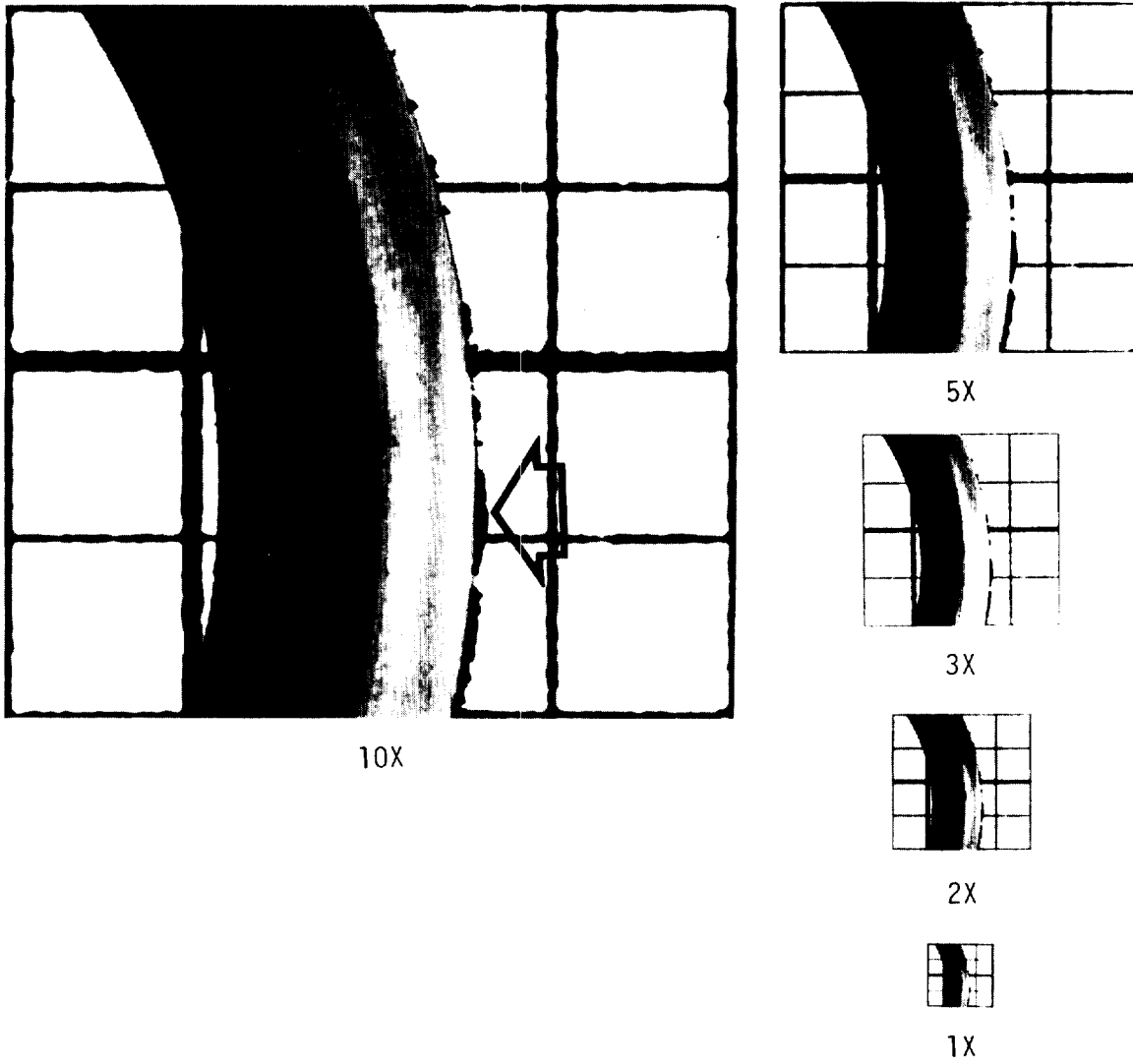

Figure 49 - Excessive flash,  
unacceptable,  
W = 0.139" (3.53 mm.)

MIL-STD-413C  
8 December 1980

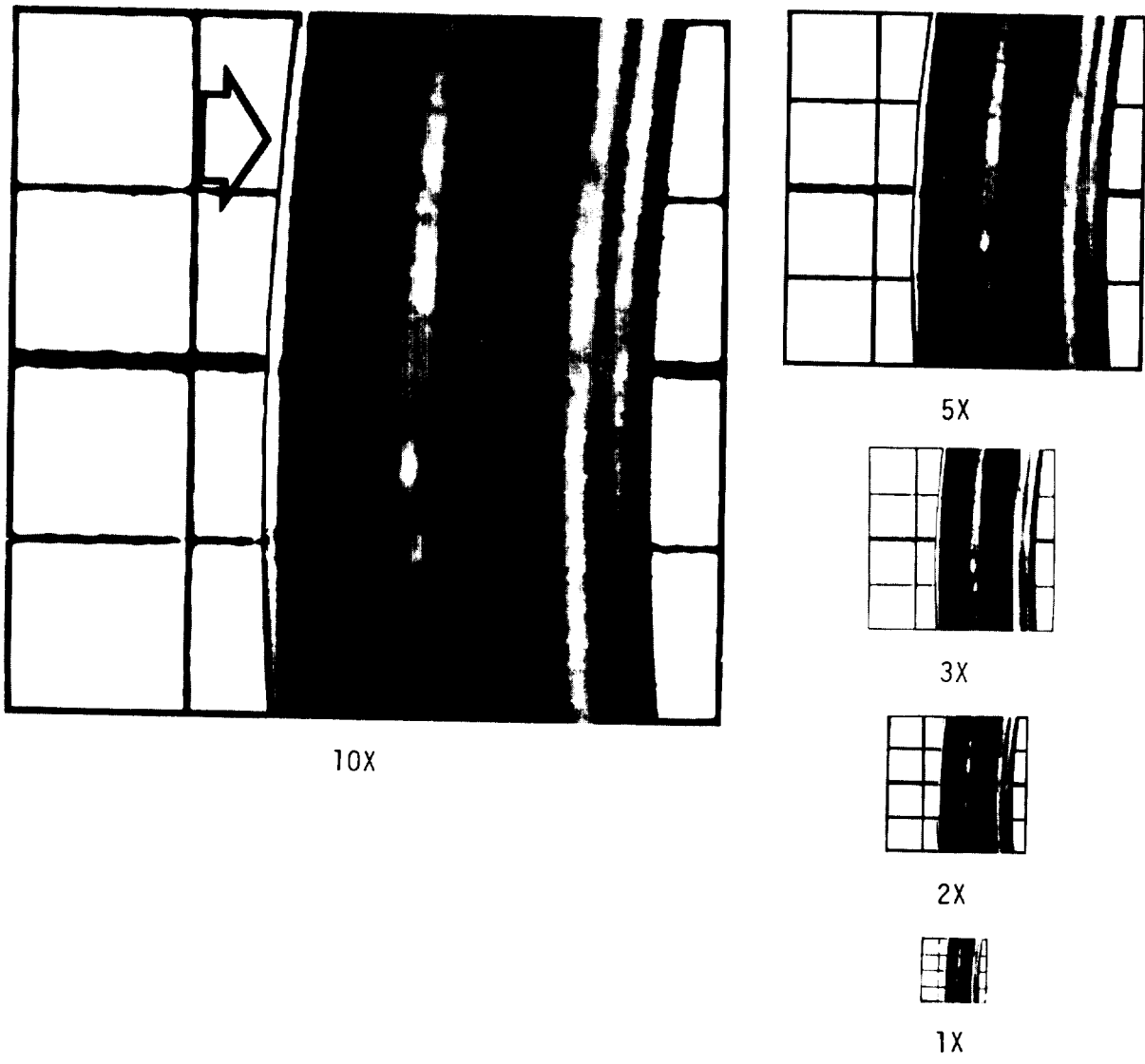

Figure 50 - Excessive flash,  
acceptable,  
W = 0.210" (5.33 mm.)

MIL-STD-413C  
8 December 1980

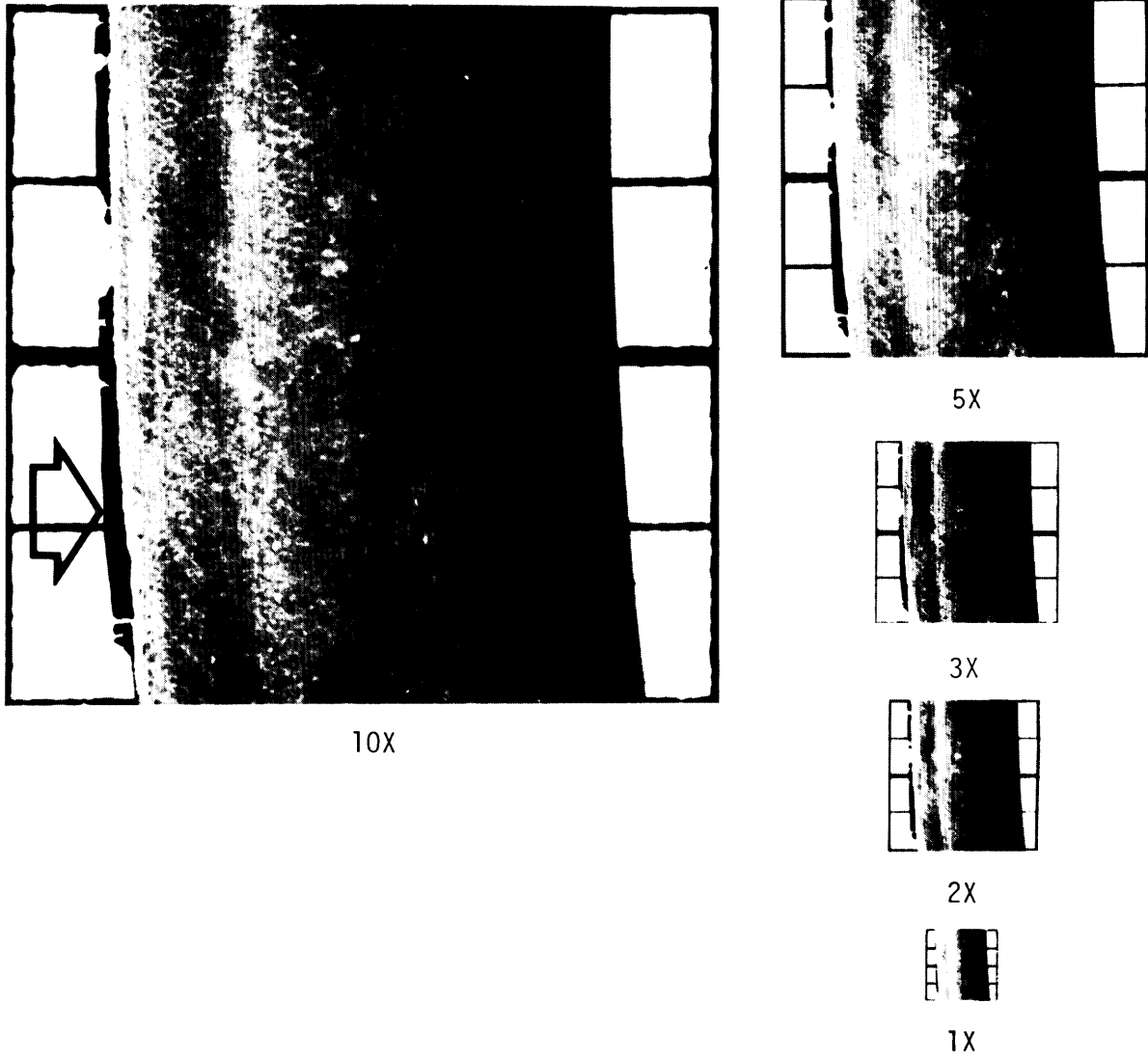

Figure 51 - Excessive flash,  
unacceptable,  
W = 0.275" (6.98 mm.)

MIL-STD-413C  
8 December 1980

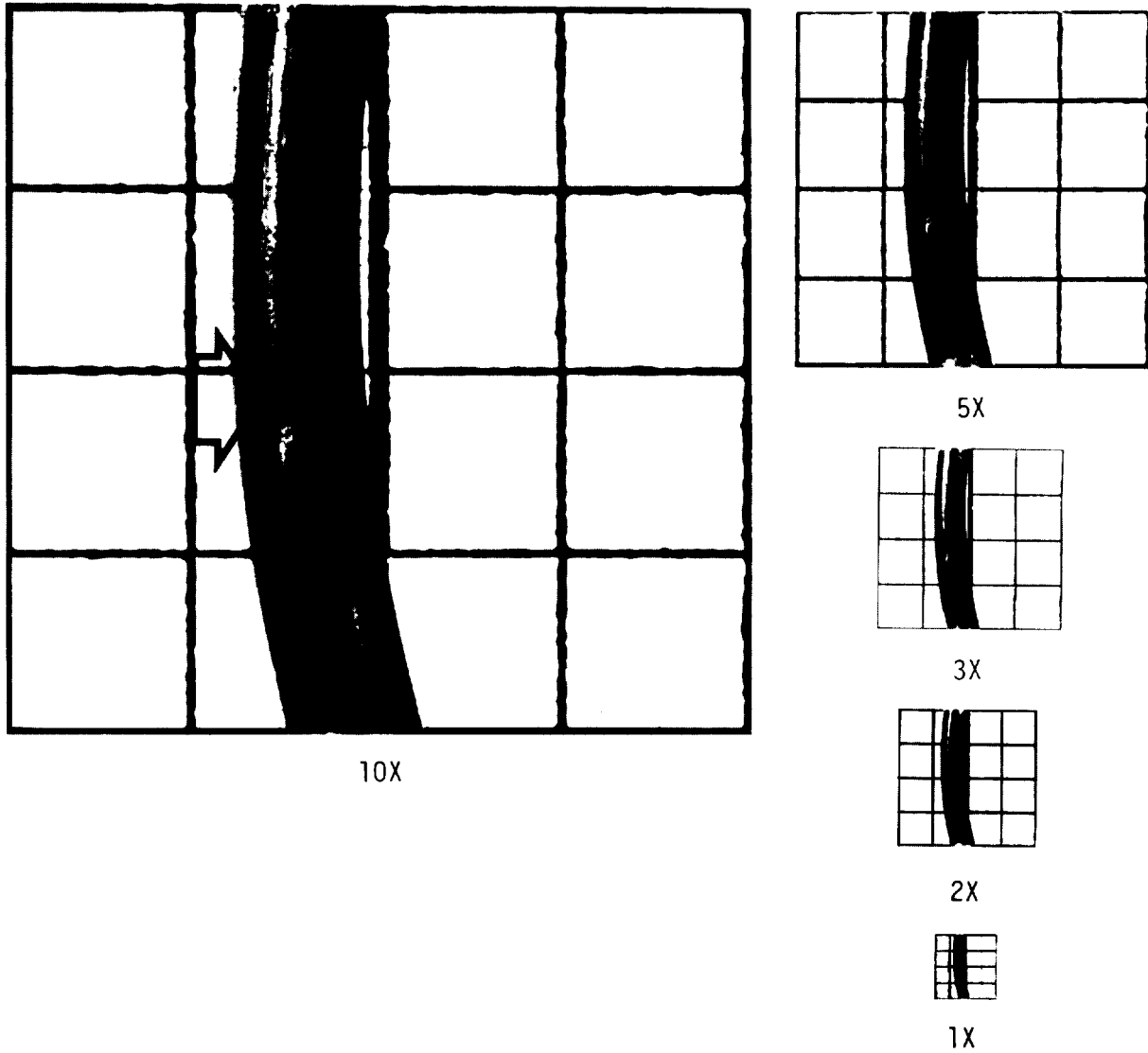

Figure 52 - Non-fill, unacceptable,  
W = 0.070" (1.78 mm.)

MIL-STD-413C  
8 December 1980

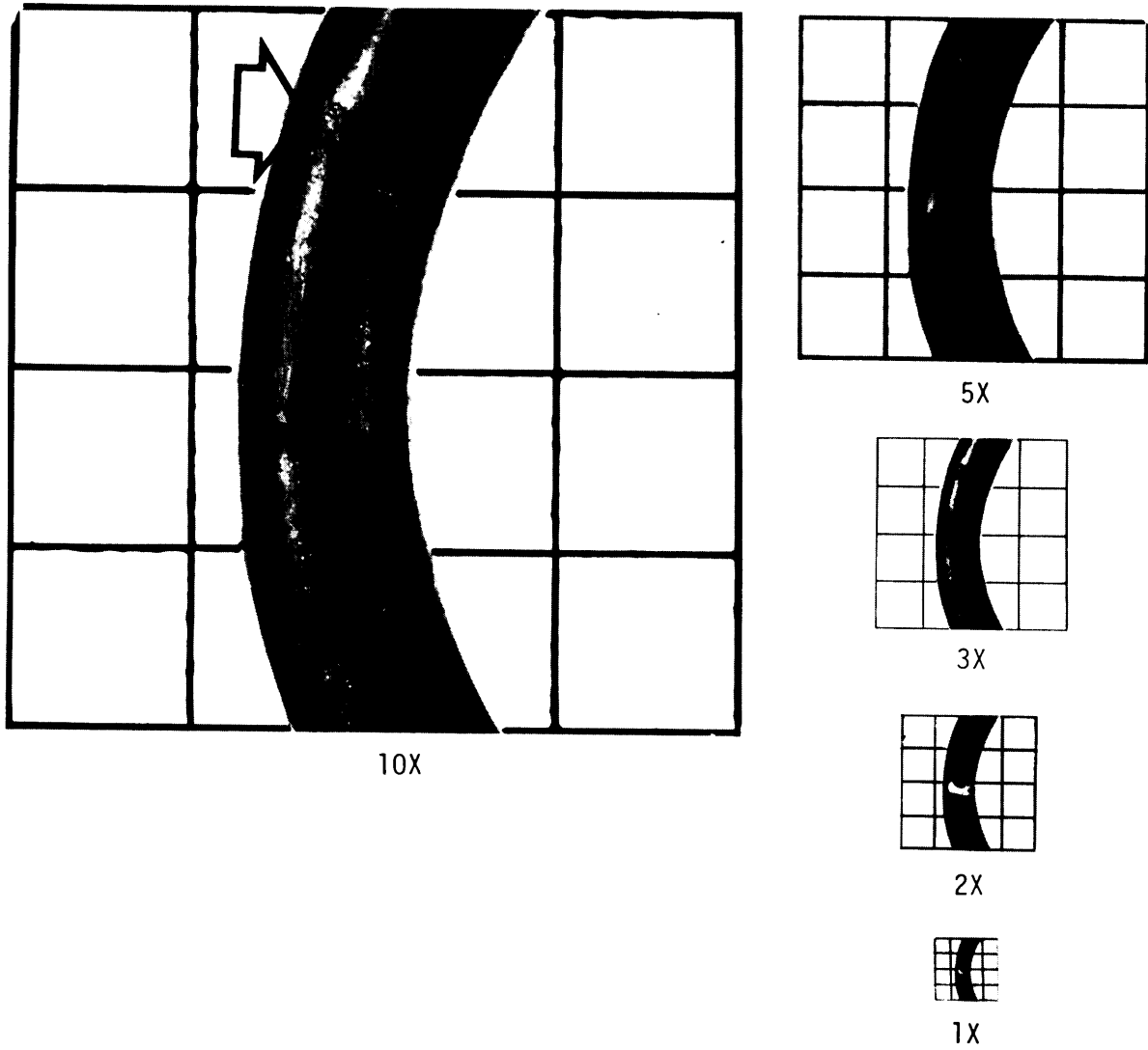

Figure 53 - Non-fill, unacceptable,  
W = 0.103" (2.62 m.)

MIL-STD-413C  
8 December 1980

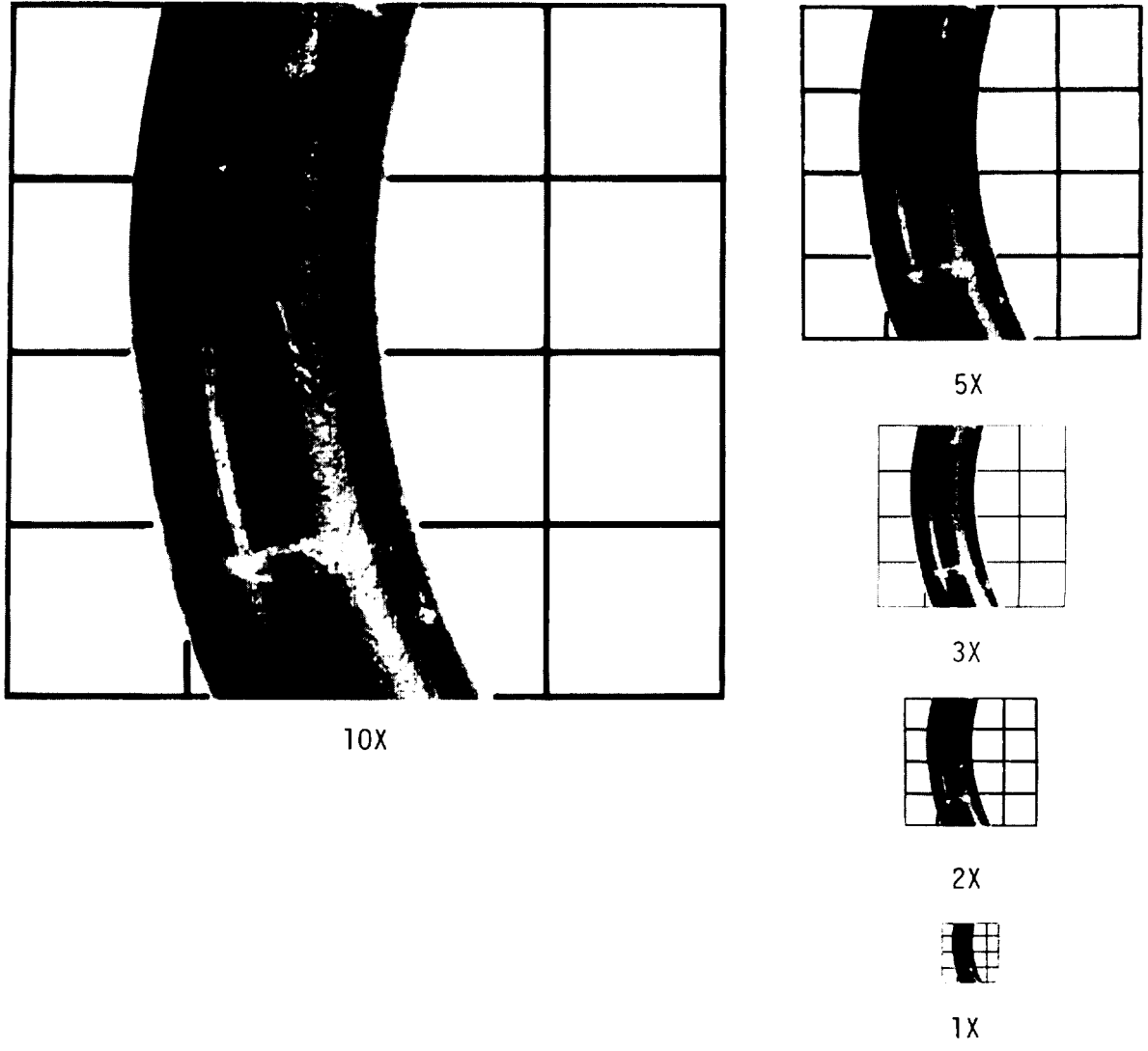

Figure 54 - Non-fill, acceptable,  
W = 0.139" (3.53 mm.)

MIL-STD-413C  
8 December 1980

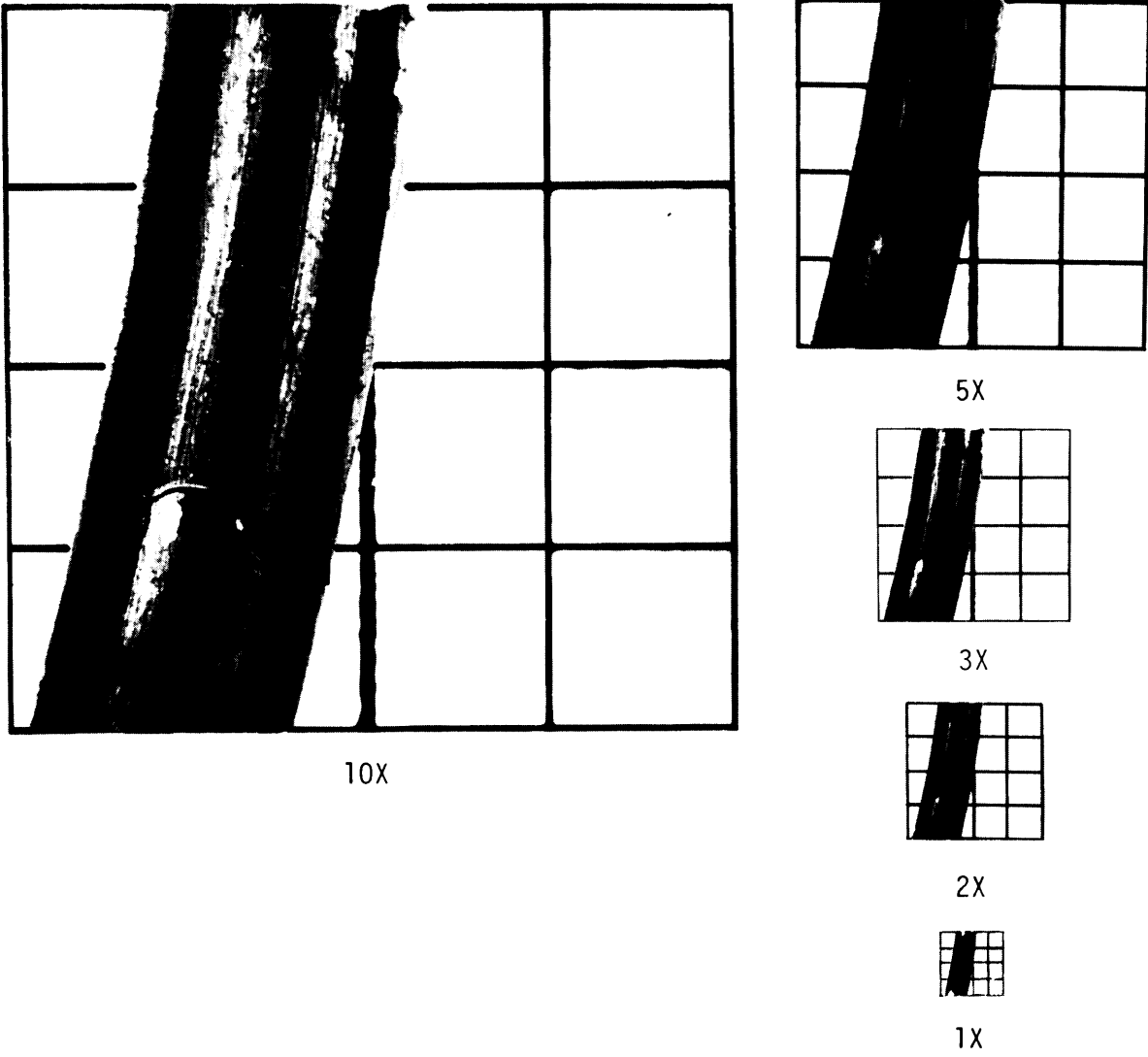

Figure 55 - Non-fill, unacceptable,  
W= 0.139" (3.53 mm.)

MIL-STD-413C  
8 December 1980

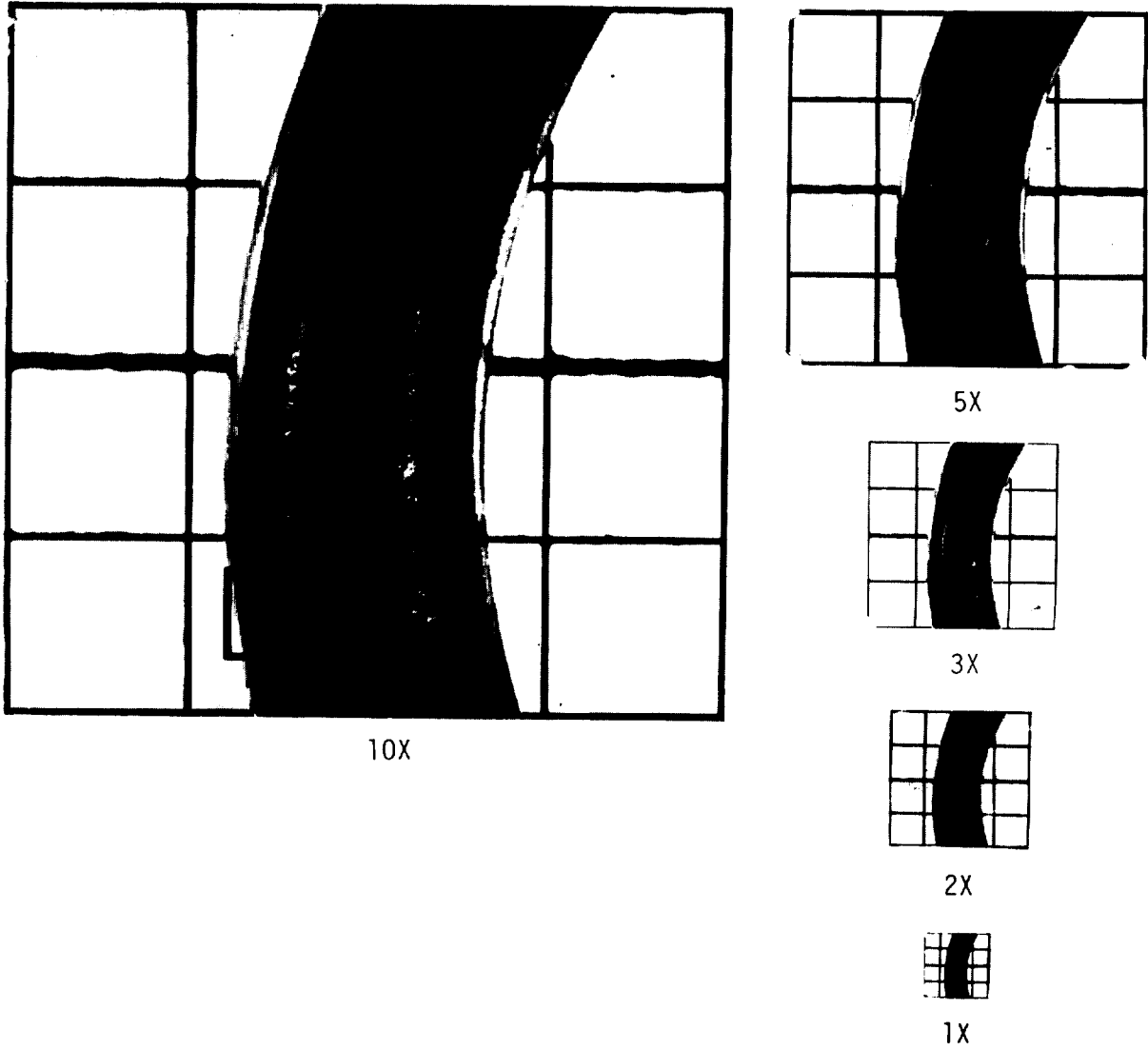

Figure 56 - Non-fill, unacceptable,  
W = 0.139" (3.53 mm.)

MIL-STD-413C  
8 December 1980

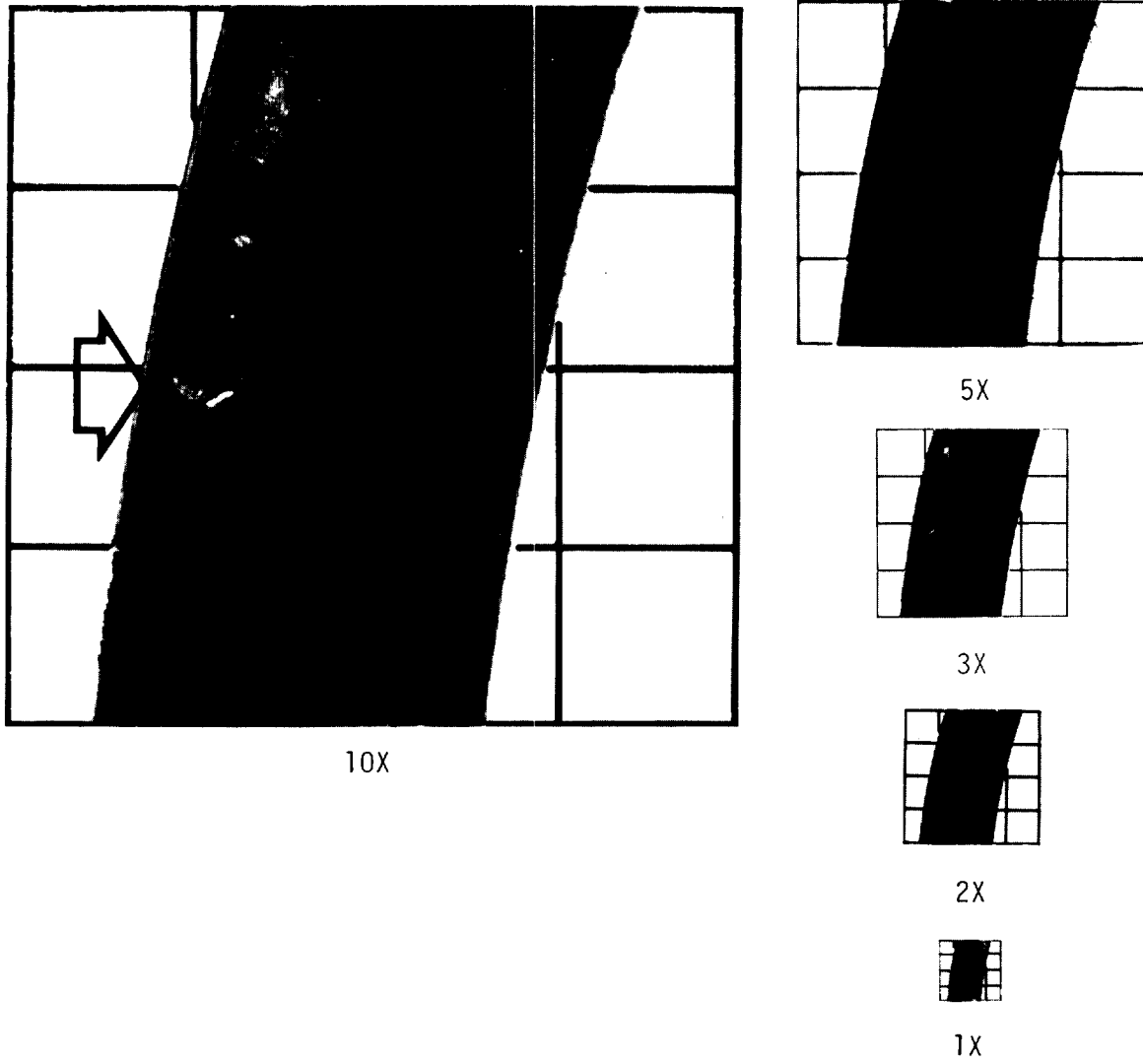

Figure 57 - Non-fill, unacceptable,  
W = 0.210" (5.33 mm.)

MIL-STD-413C  
8 December 1980

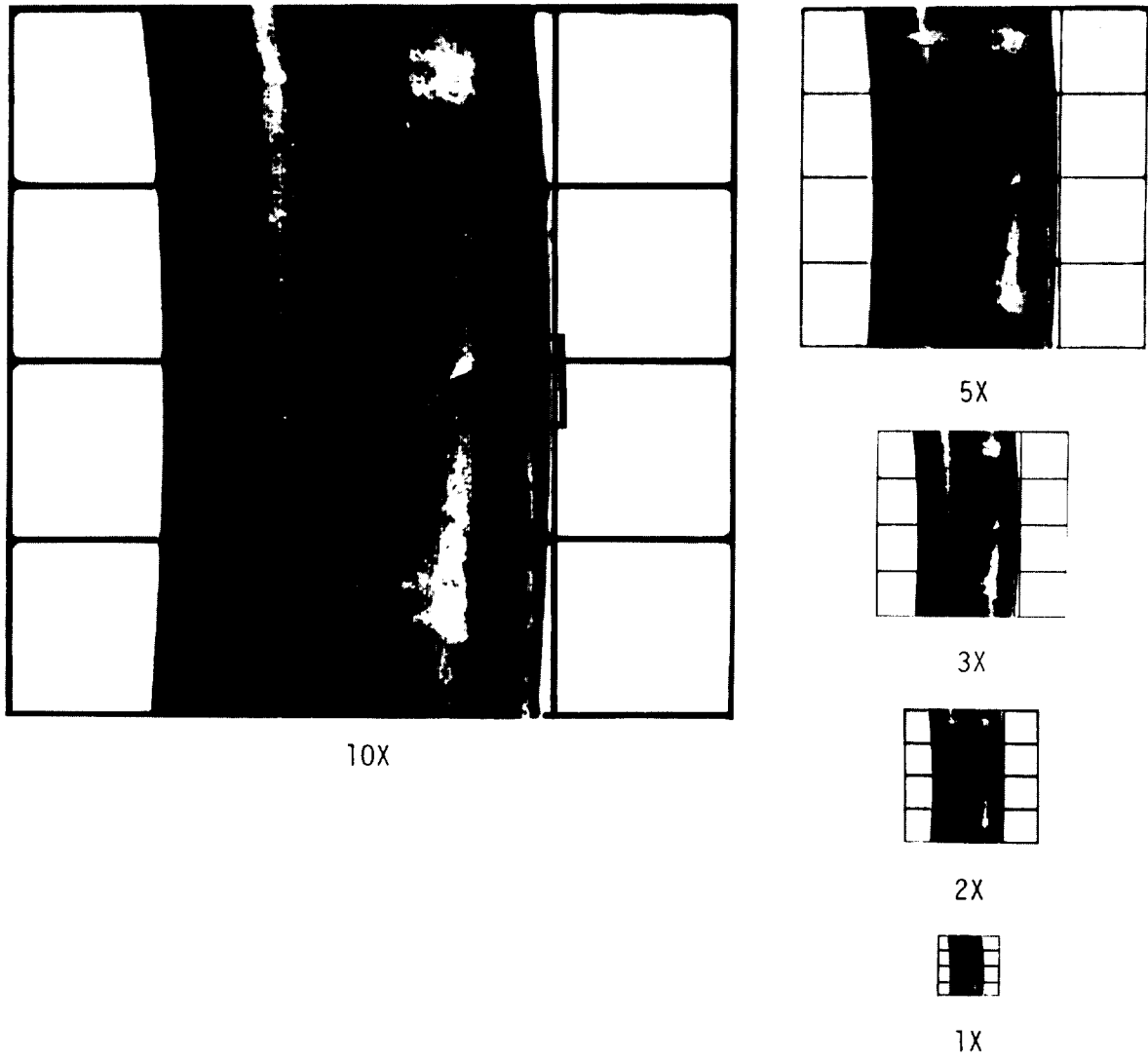
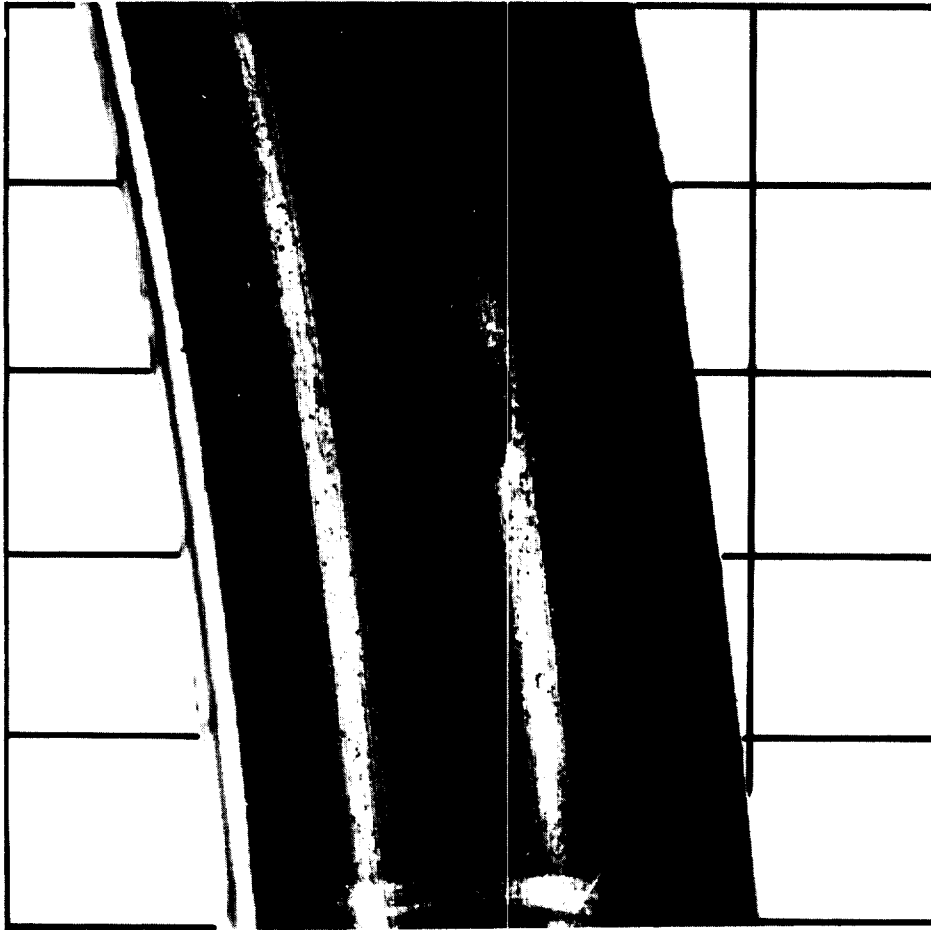
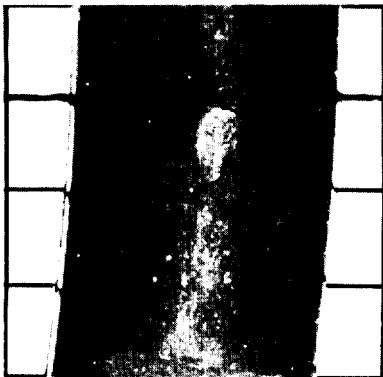

Figure 58 - Non-fill, unacceptable,  
W = 0.210" (5.33 mm.)

MIL-STD-413C  
8 December 1980



10X



5X

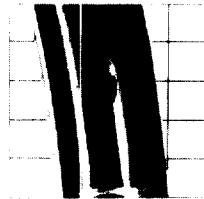

3X



2X



1X

Figure 59 - Non-fill, acceptable,  
W = 0.275" (6.98 mm.)

MIL-STD-413C  
8 December 1980

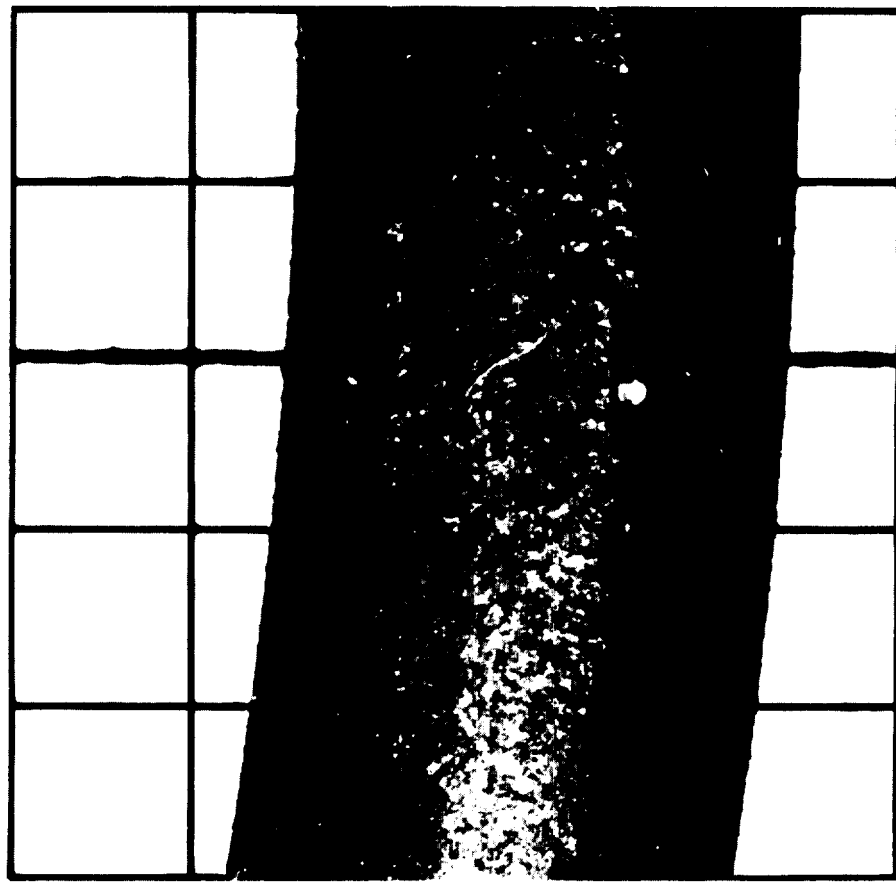

10X



5X

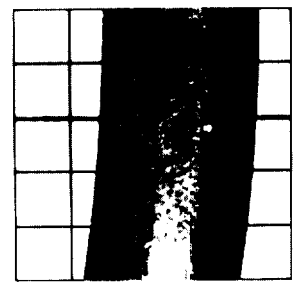

3X

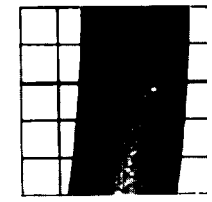

2X

Figure 60 - Non-fill, unacceptable,  
W = 0.275" (6.98 mm.)

MIL-STD-413C  
8 December 1980

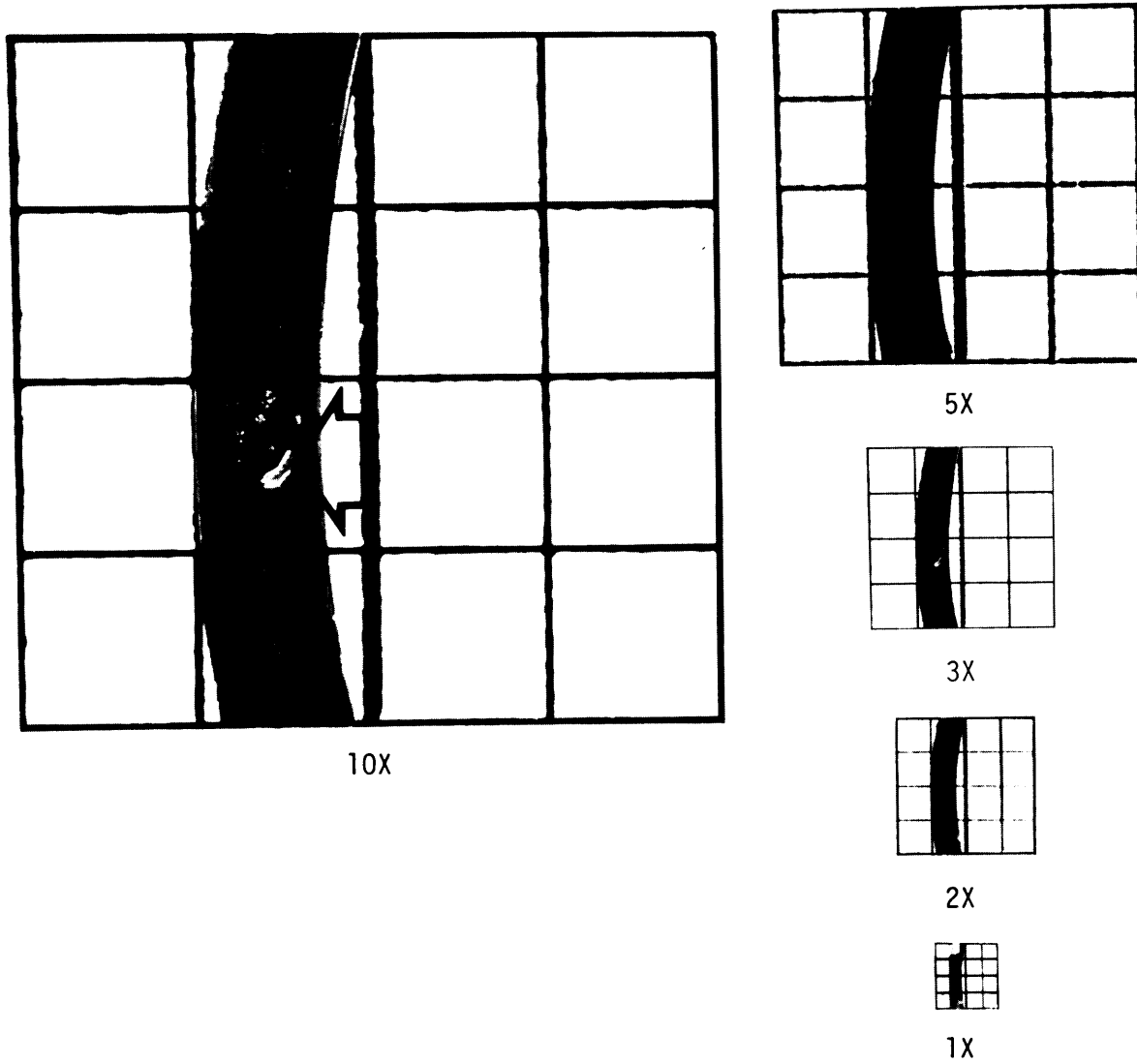

Figure 61 - Mold deposit indentations,  
unacceptable,  
W= 0.070" (1.78 mm)

MIL-STD-413C  
8 December 1980

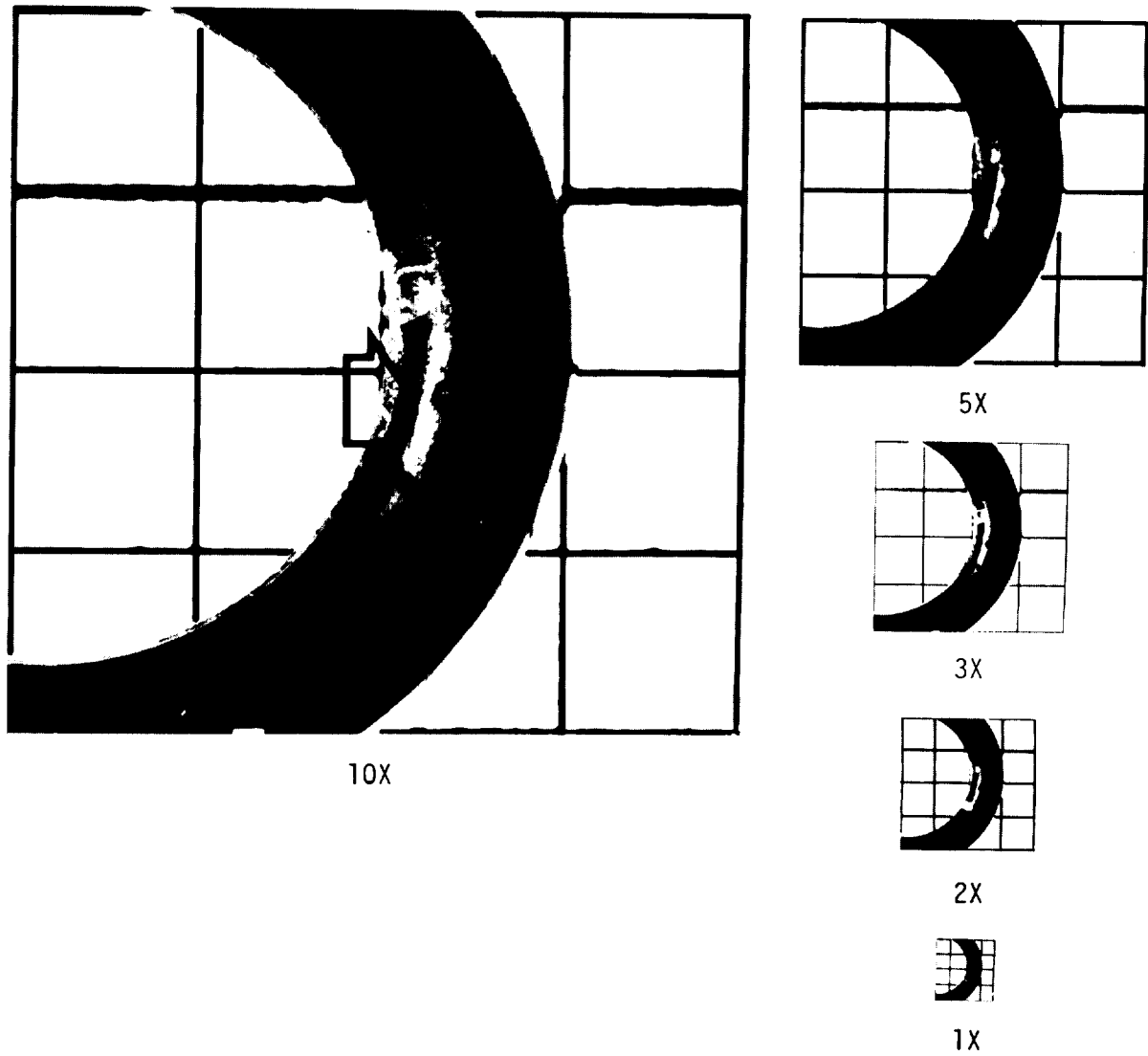

Figure 62 - Mold deposit indentations,  
acceptable,  
W = 0.103" (2.62 mm.)

MIL-STD-413C  
8 December 1980

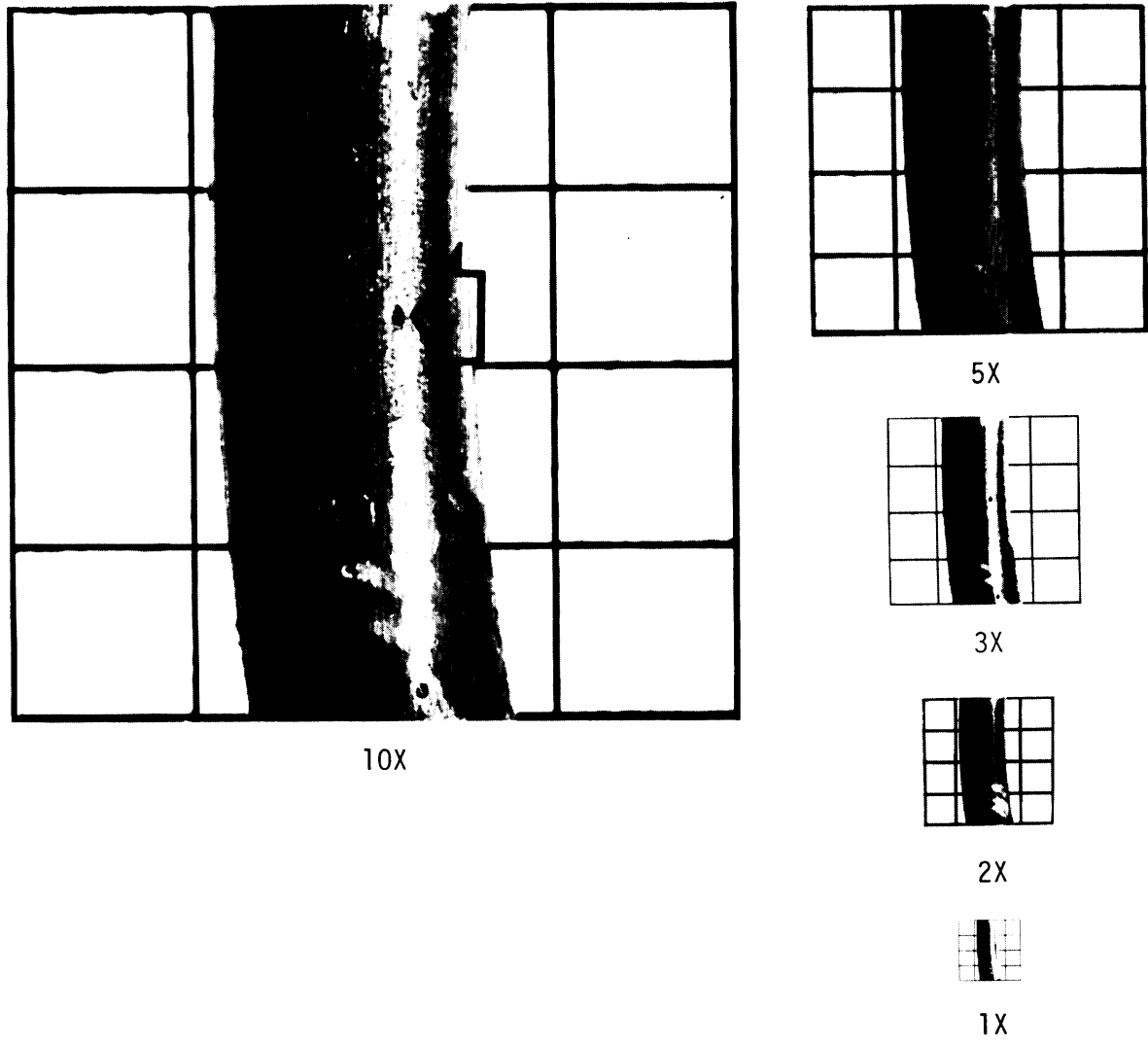

Figure 63 - Mold deposit indentations,  
acceptable,  
w = 0.139" (3.53 mm.)

MIL-STD-413C  
8 December 1980

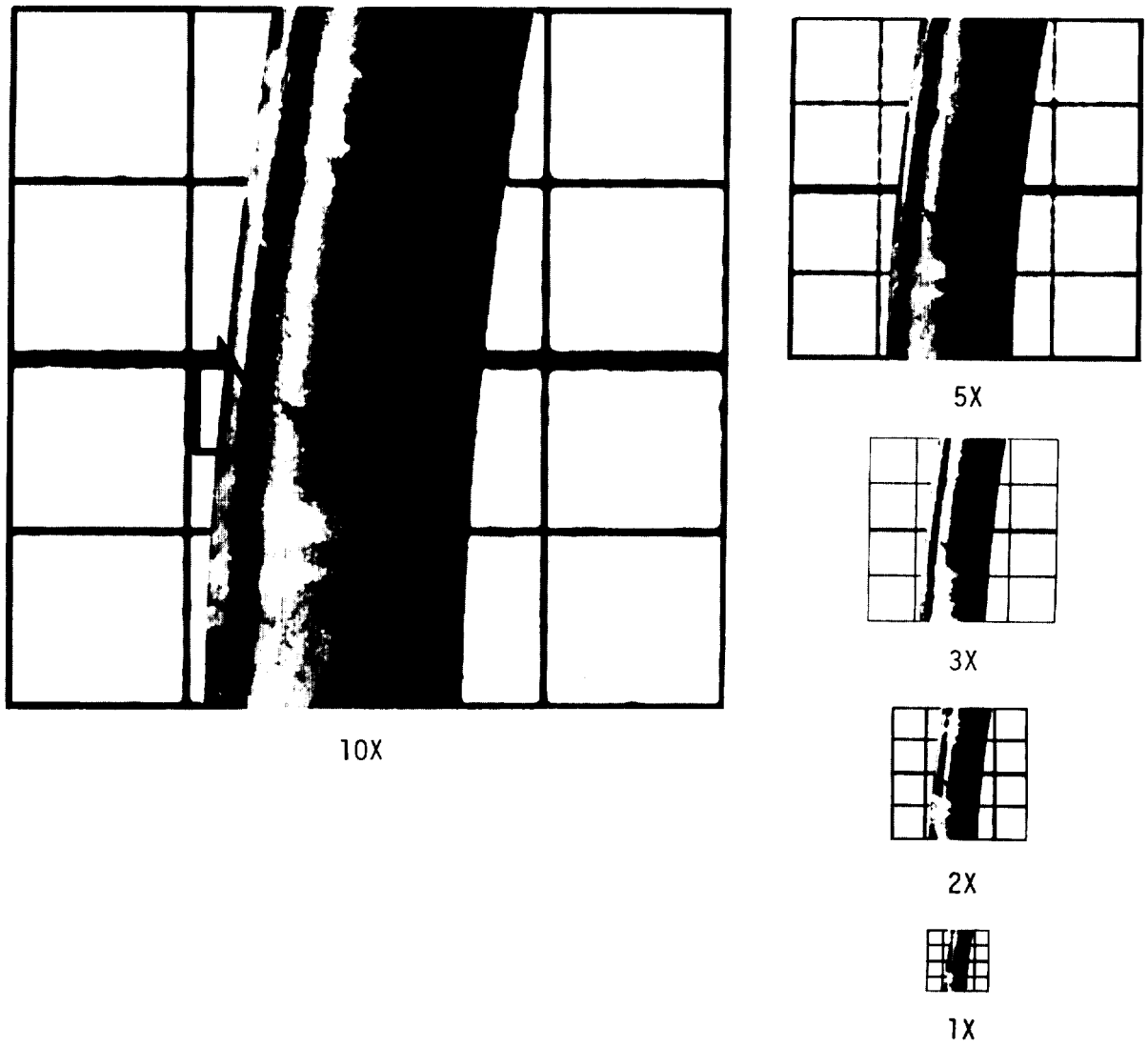

Figure 64 - Mold deposit indentations,  
unacceptable,  
W = 0.139" (3.53 mm.)

MIL-STD-413C  
8 December 1980

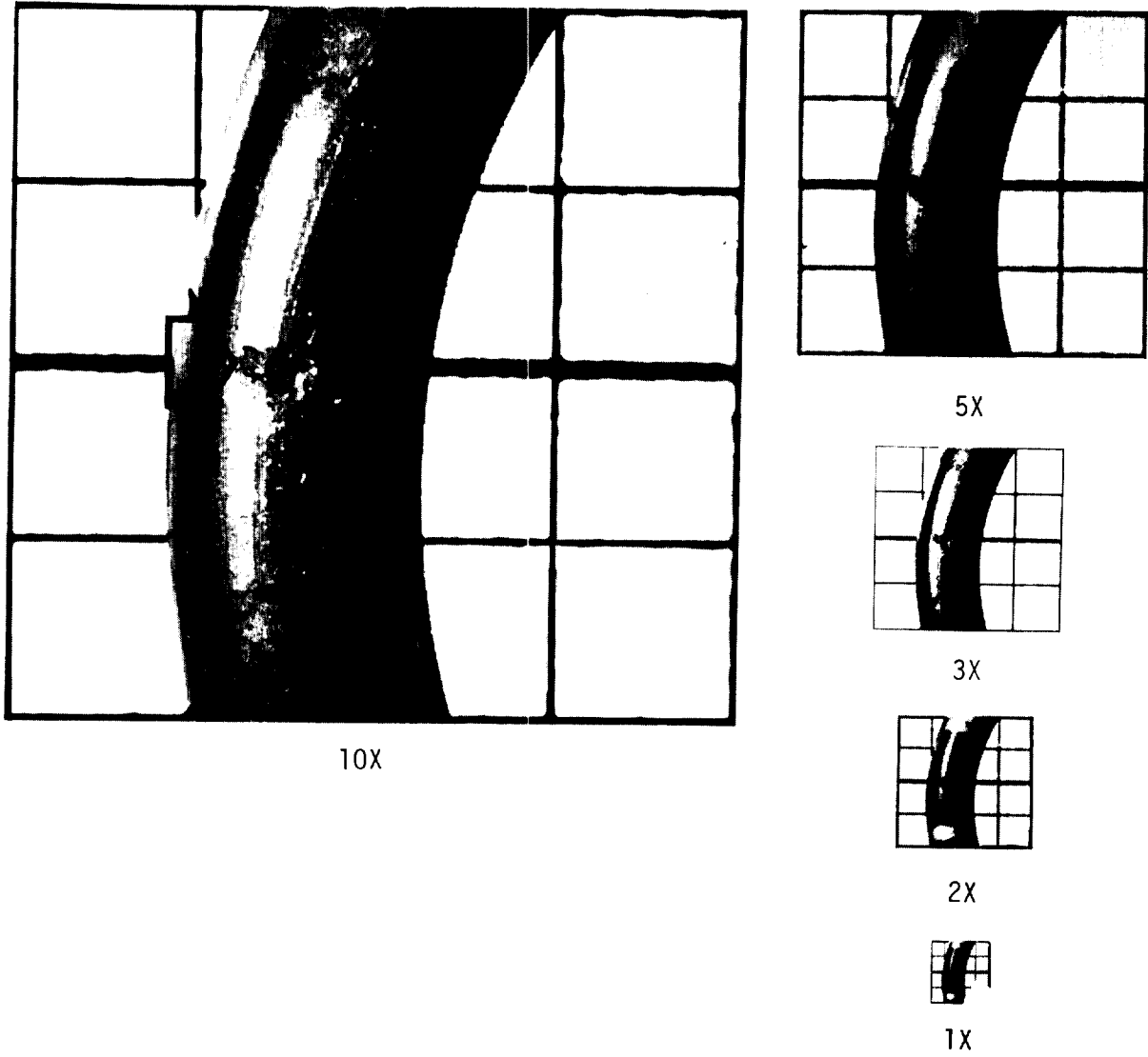

Figure 65 - Mold deposit indentations,  
unacceptable,  
W = 0.139" (3.53 mm.)

MIL-STD-413C  
8 December 1980

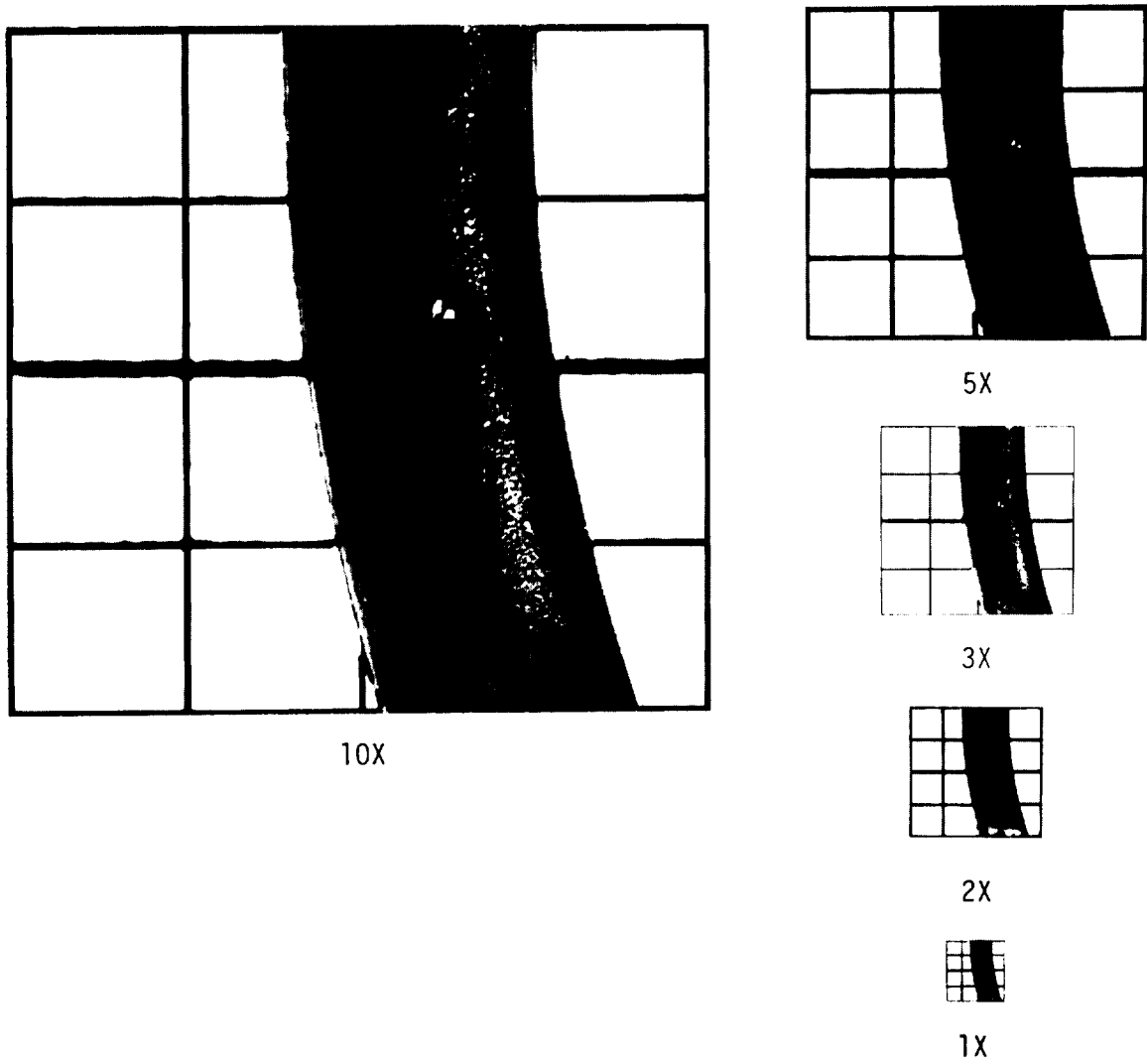

Figure 66 - Mold deposit indentations,  
unacceptable,  
W = 0.139" (3.53 mm.)

MIL-STD-413C  
8 December 1980

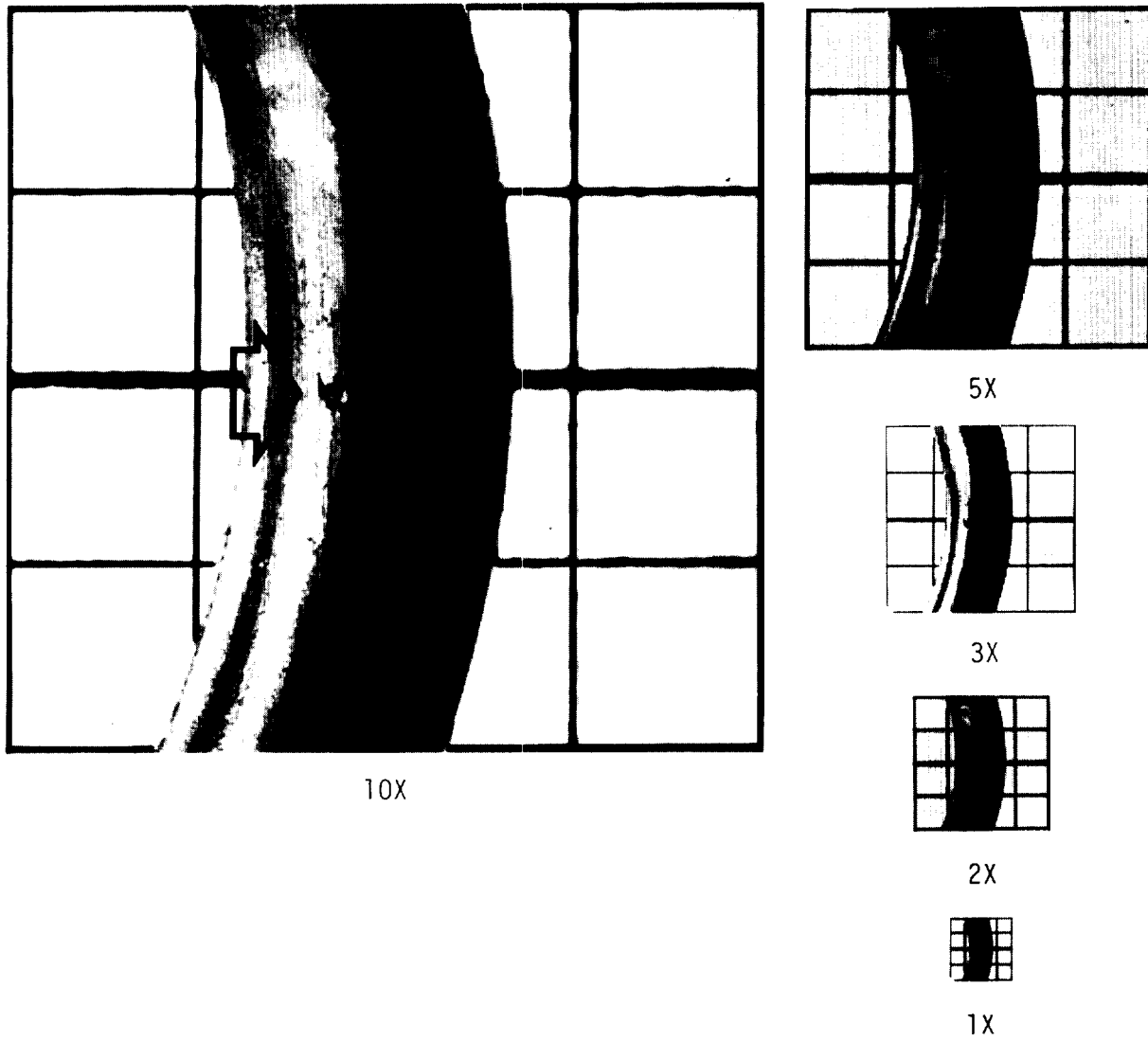

Figure 67 - Mold deposit indentations,  
acceptable,  
W = 0.139" (3.53 mm.)

MIL-STD-413C  
8 December 1980

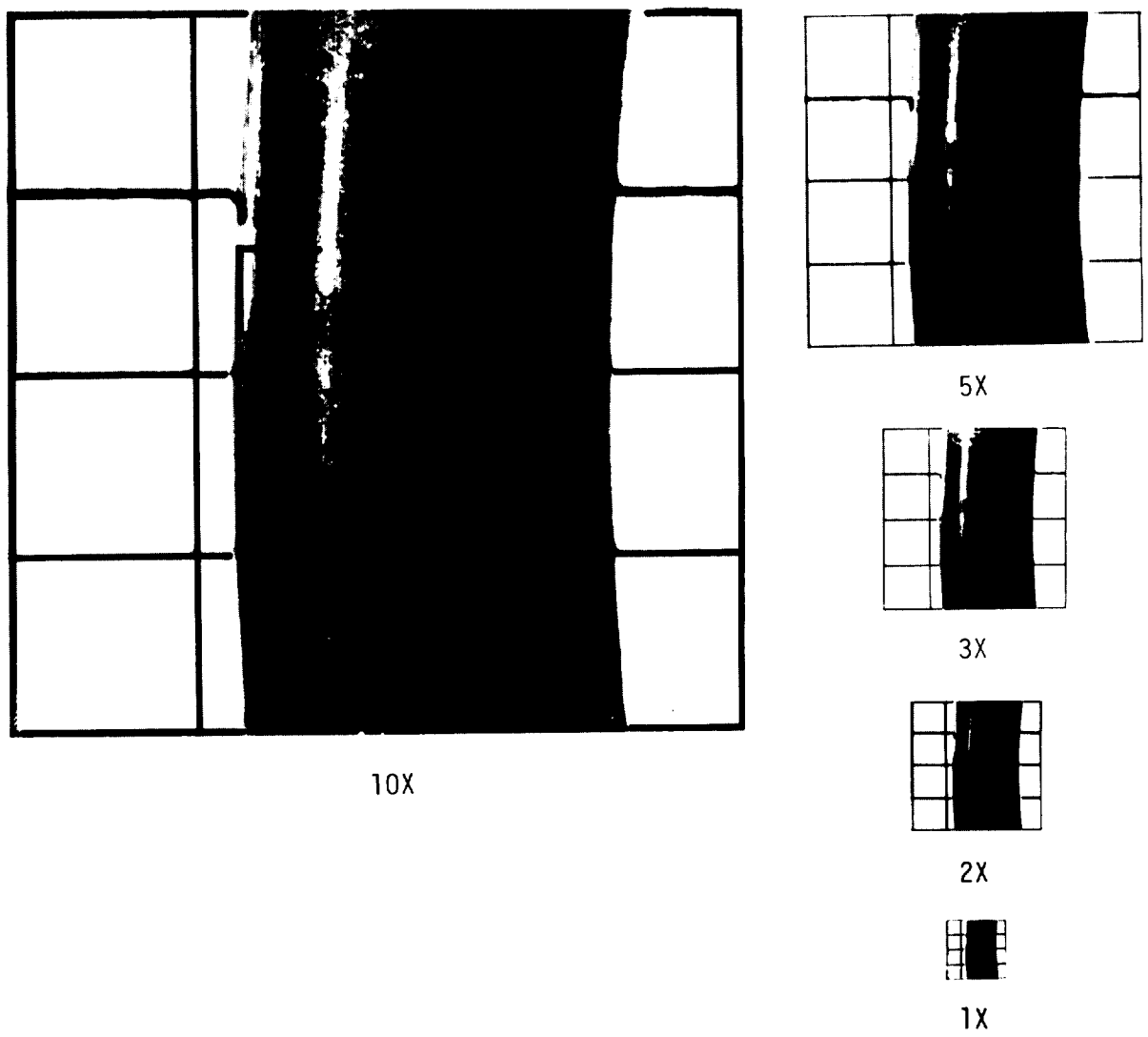

Figure 68 - Mold deposit indentations,  
acceptable,  
W = 0.210" (5.33 mm.)

MIL-STD-413C  
8 December 1980

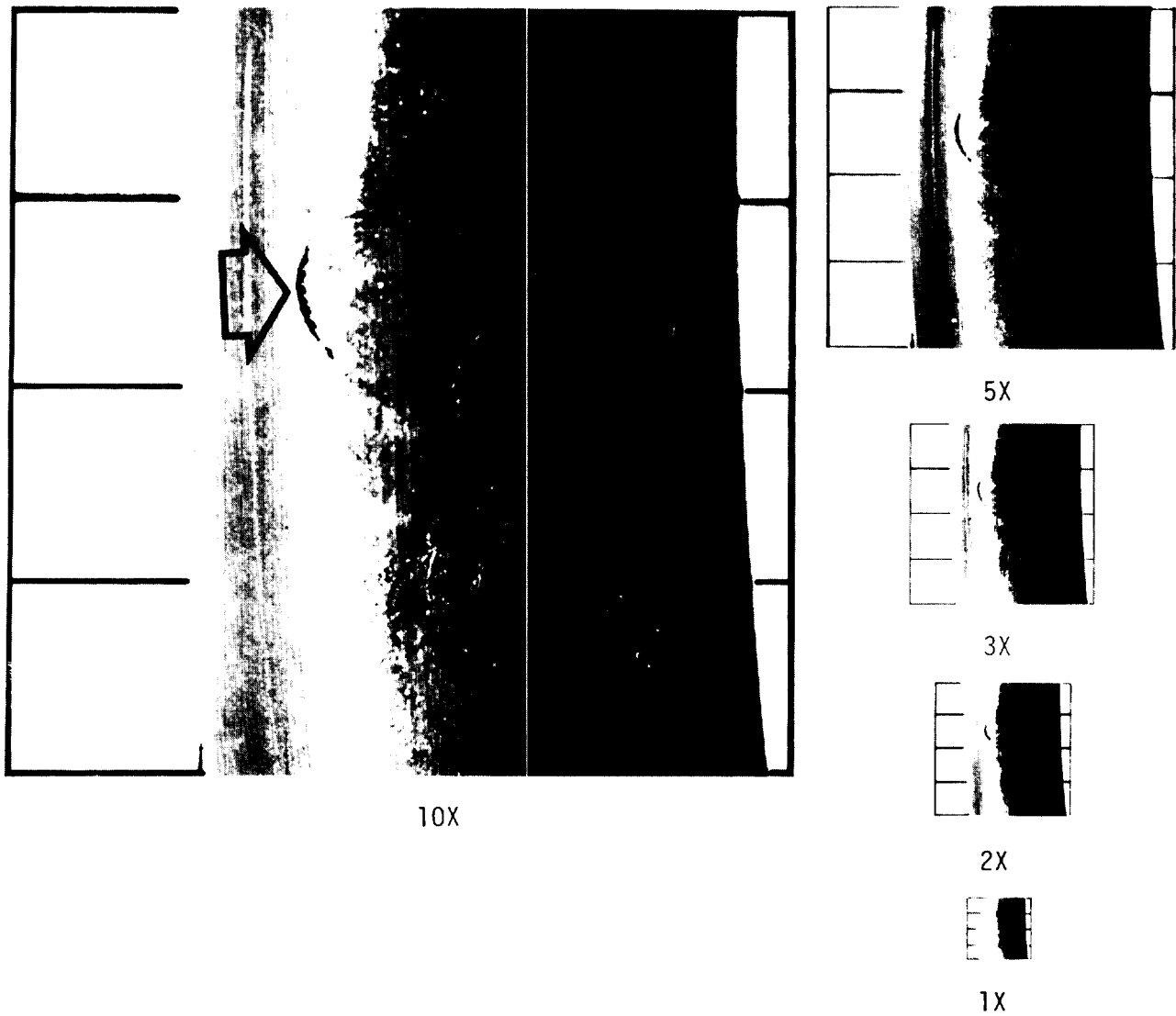

Figure 69 - Mold deposit indentations,  
unacceptable,  
W = 0.275" (6.98 mm.)

MIL-STD-413C  
8 December 1980

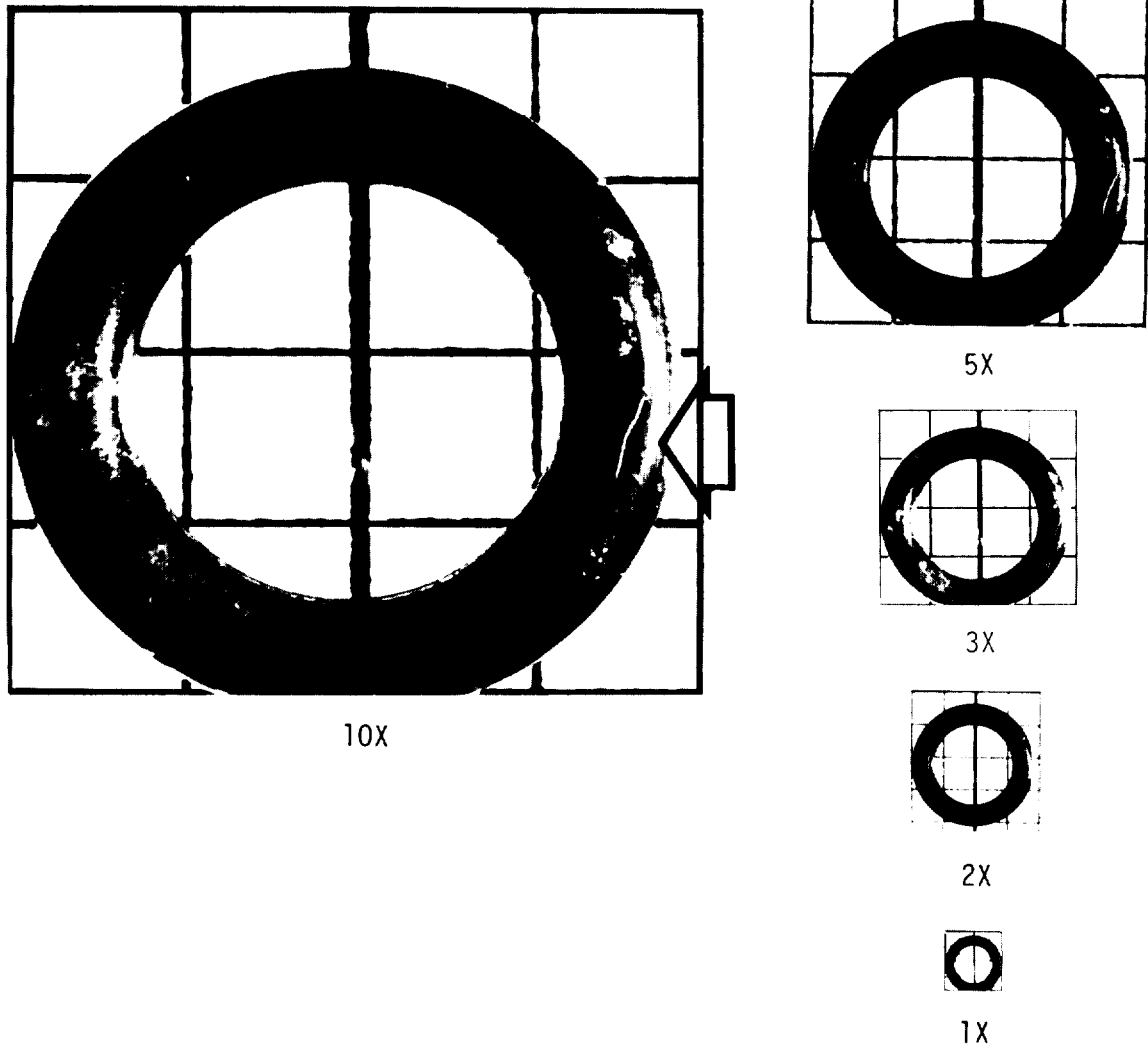

Figure 70 - Flow marks, unacceptable,  
W = 0.070" (1.78 mm.)

MIL-STD-413C  
8 December 1980

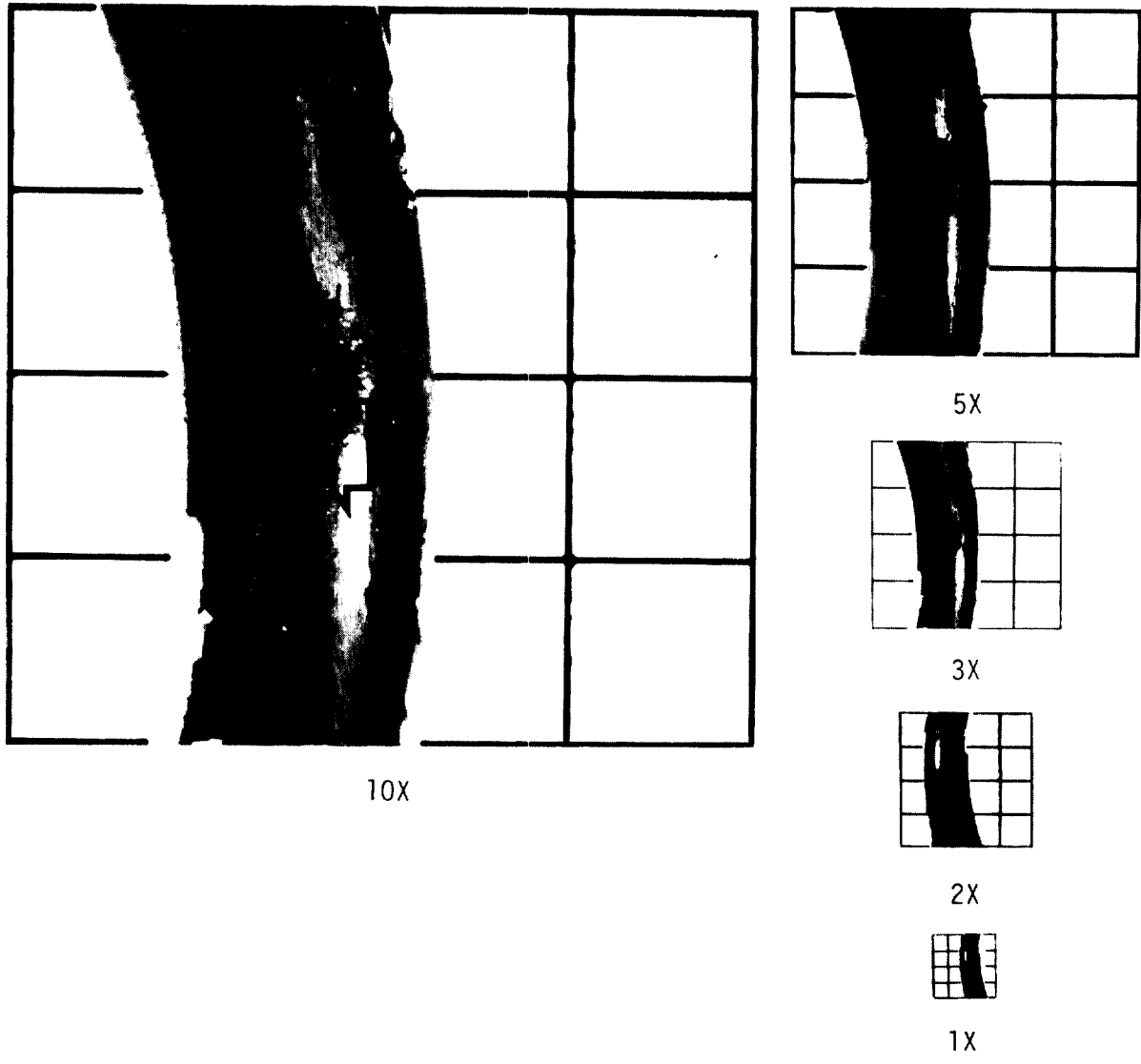

Figure 71 - Flow marks, unacceptable,  
W = 0.139" (3.53 mm.)

MIL-STD-413C  
8 December 1980

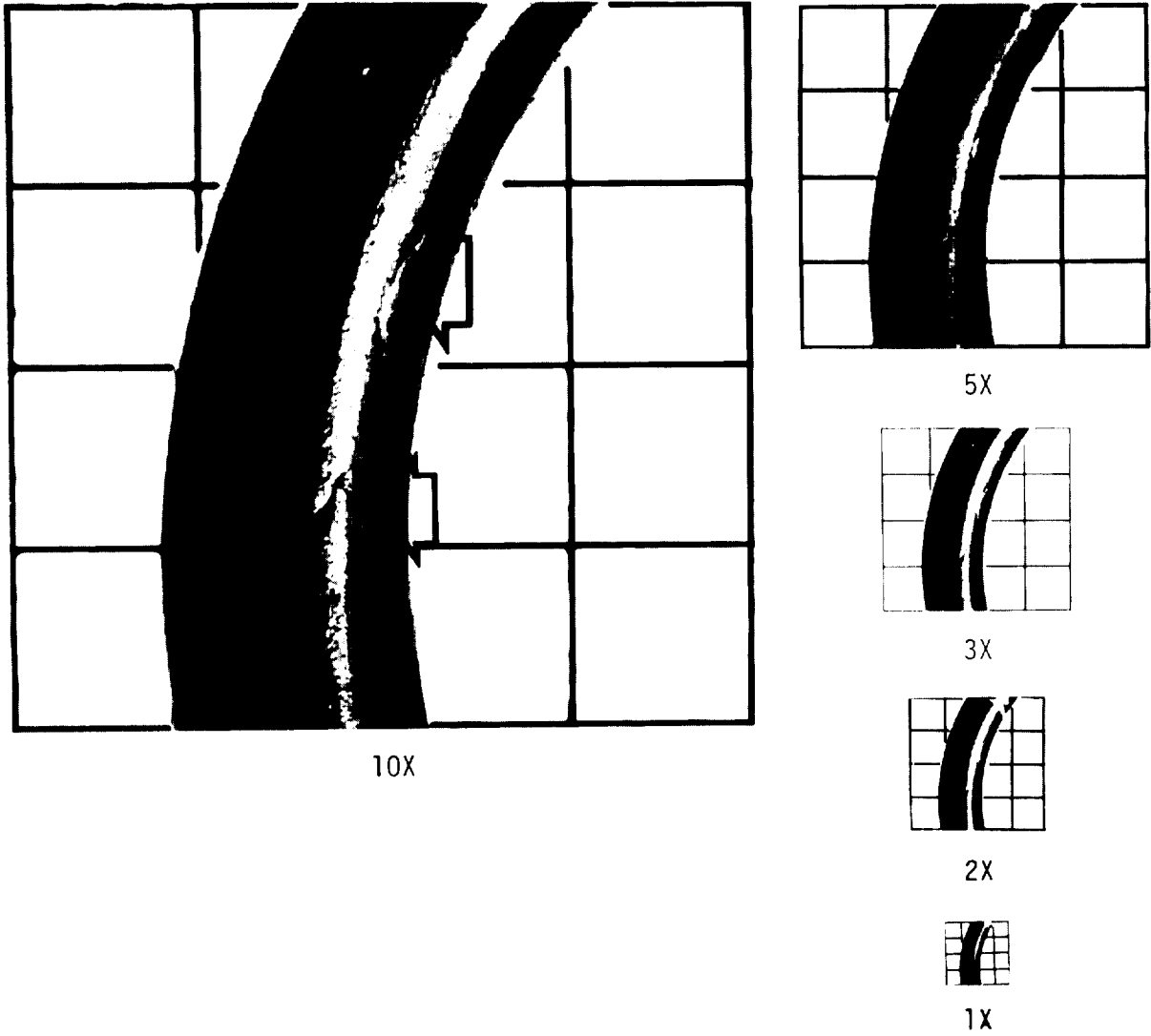

Figure 72 - Flow marks, acceptable,  
W = 0.139" (3.53 mm.)

MIL-STD-413C  
8 December 1980

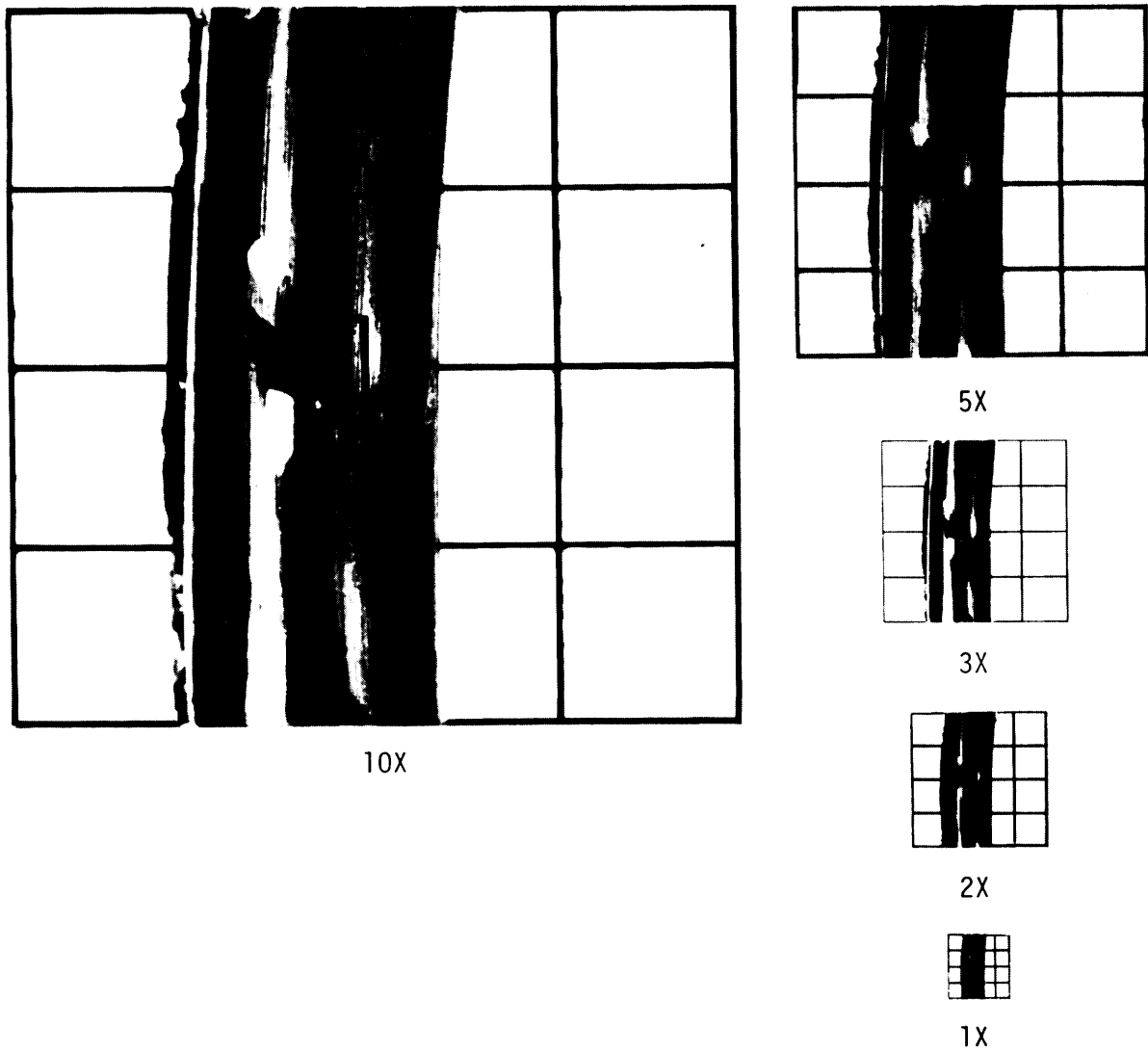

Figure 73 - Flow marks, unacceptable,  
W= 0.139" (3.53 mm.)

MIL-STD-413C  
8 December 1980

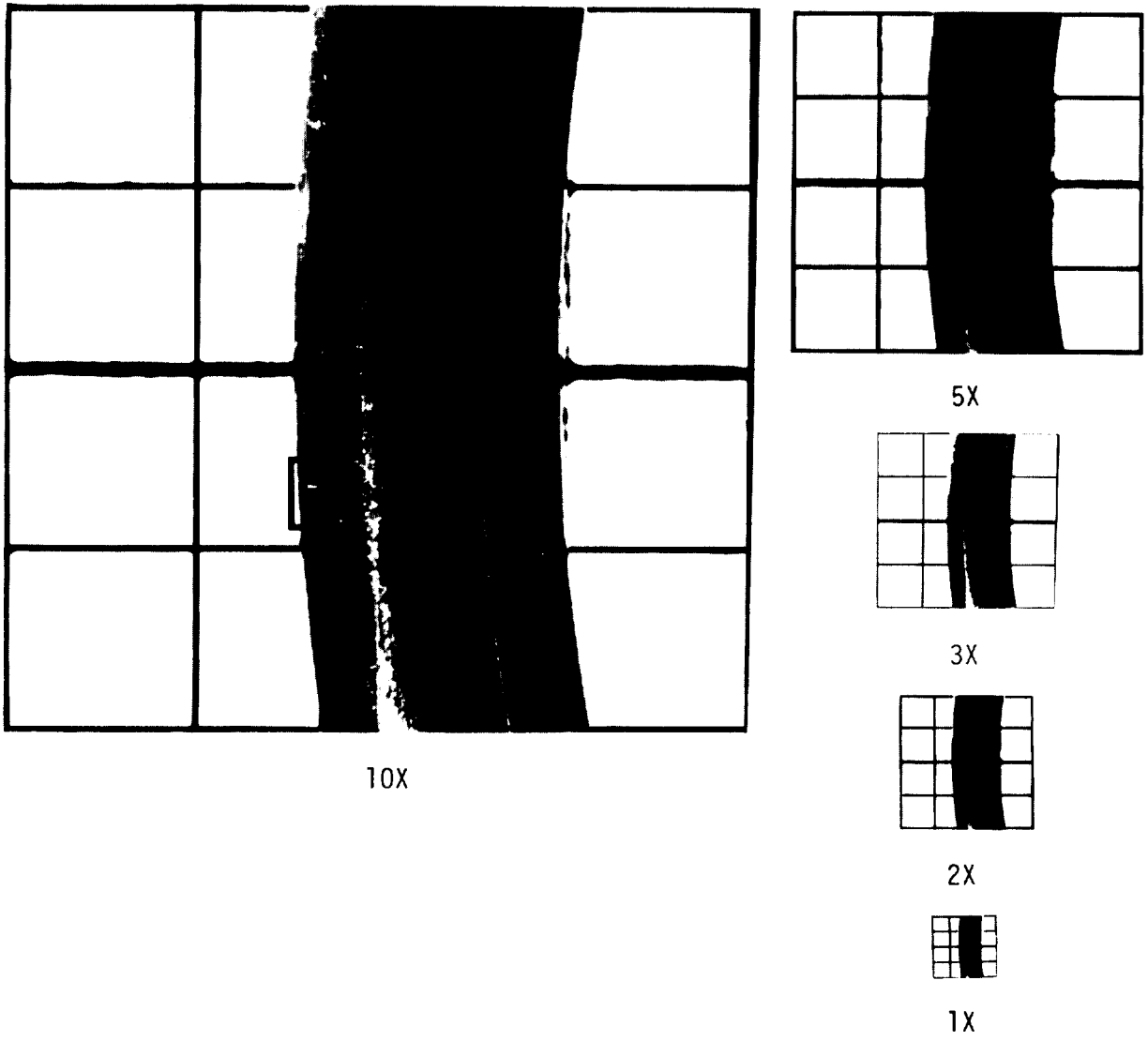

Figure 74 - Flow marks, acceptable,  
W = 0.139" (3.53 mm.)

MIL-STD-413C  
8 December 1980

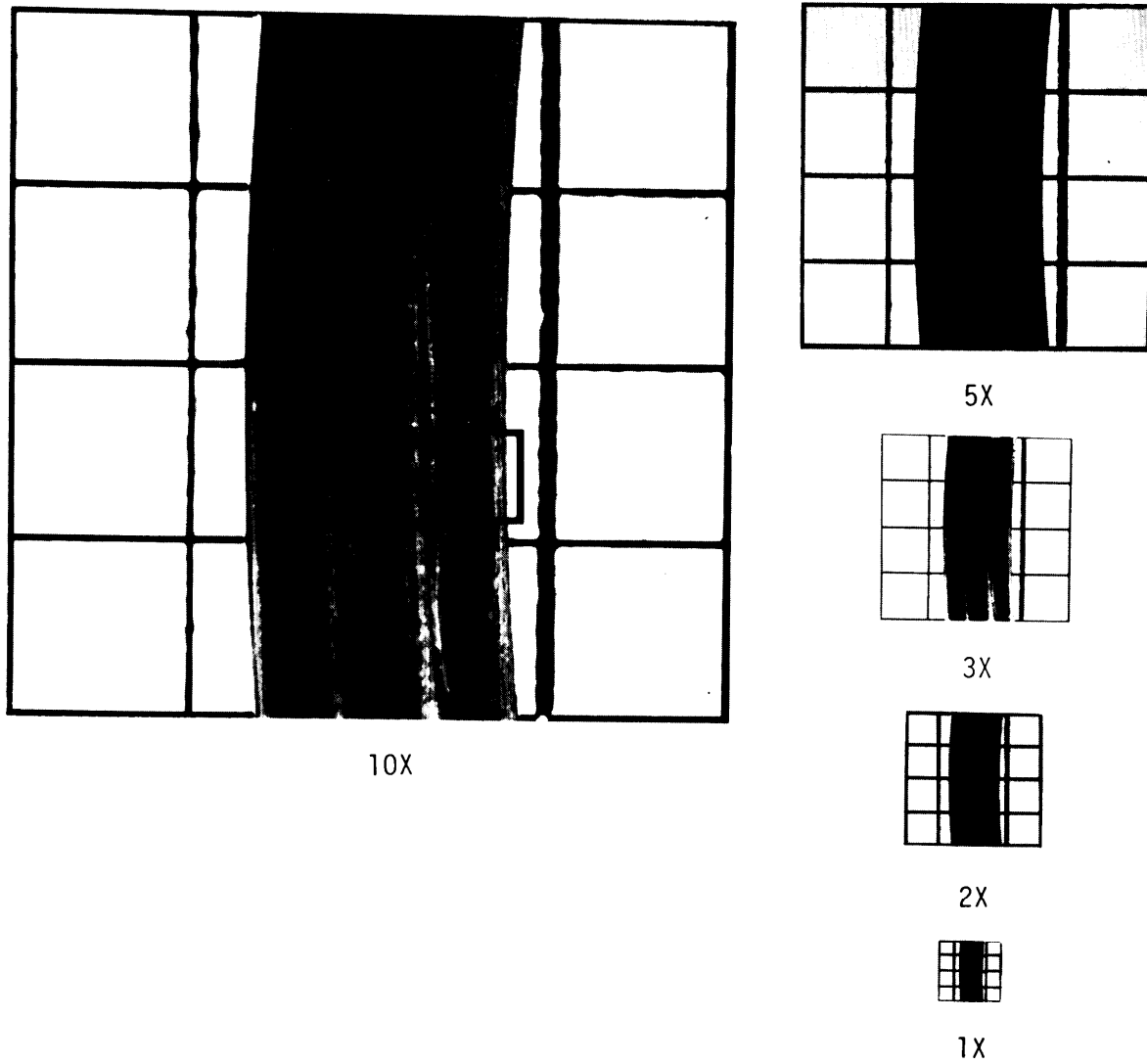

Figure 75 - Flow marks, unacceptable,  
W= 0.139" (3.53 mm.)

MIL-STD-413C  
8 December 1980

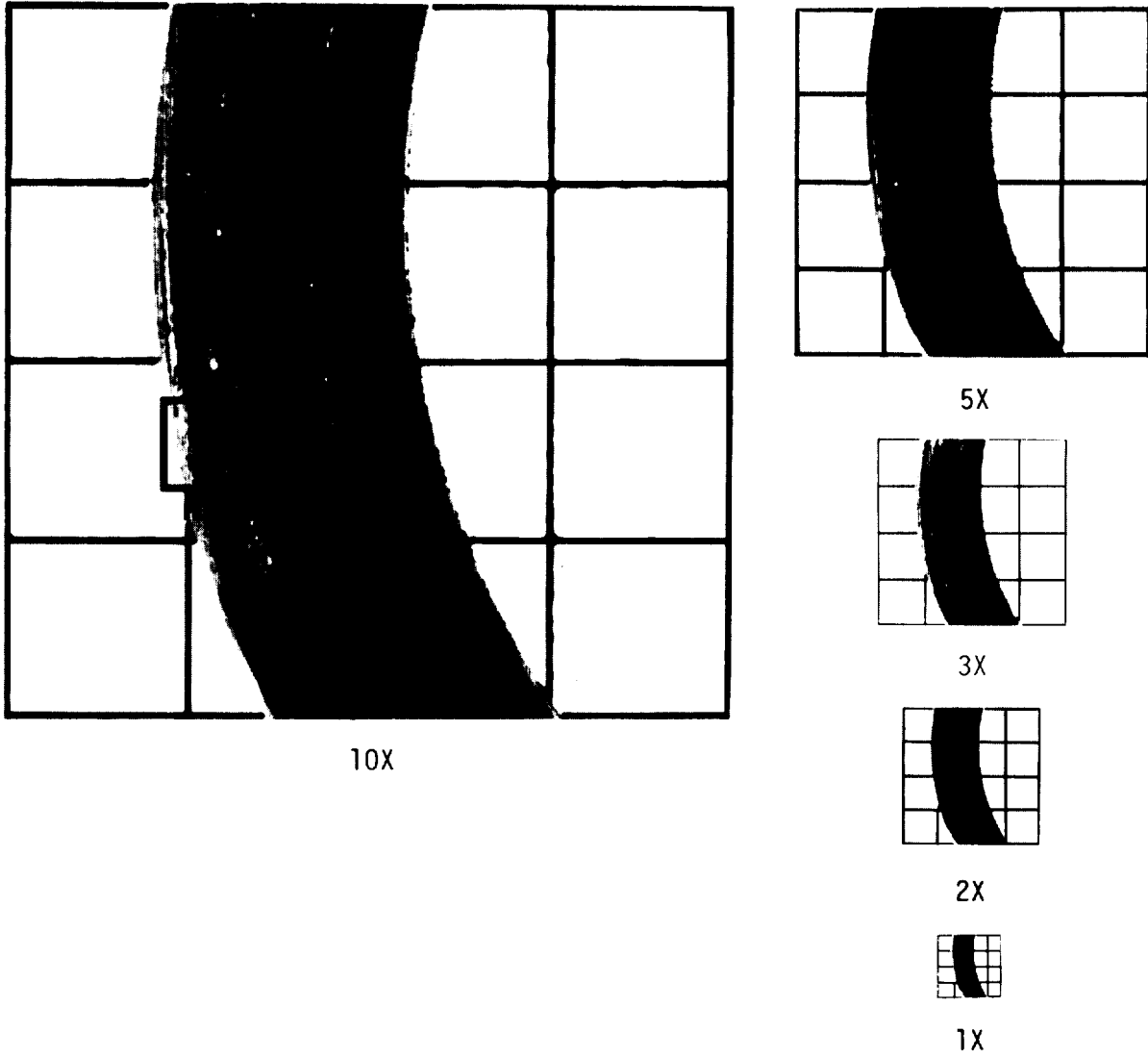

Figure 76 - Flow marks, unacceptable,  
W = 0.139" (3.53 mm.)

MIL-STD-413C  
8 December 1980

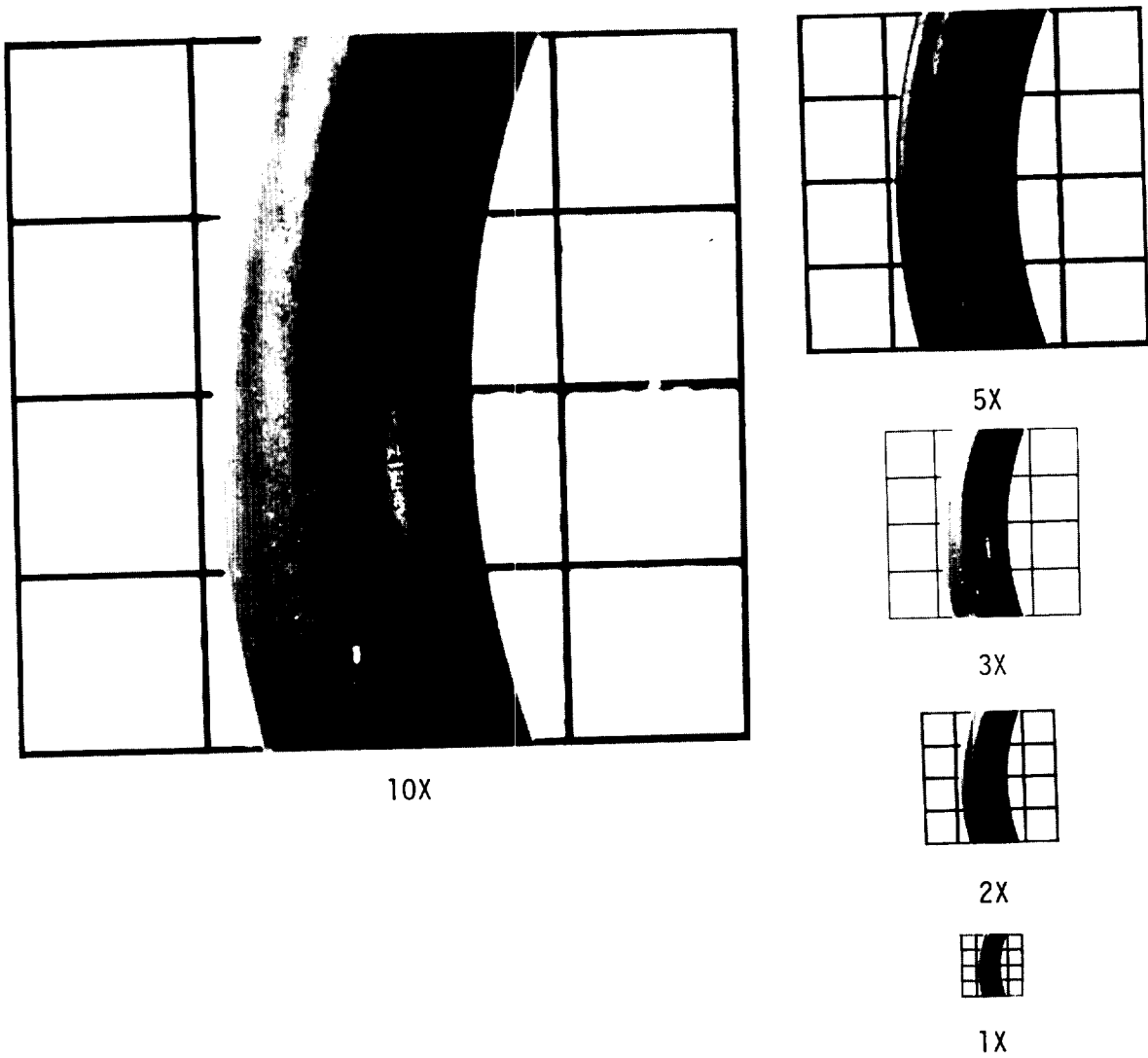

Figure 77 - Flow marks, acceptable,  
W = 0.139" (3.53 mm.)

MIL-STD-413C  
8 December 1980

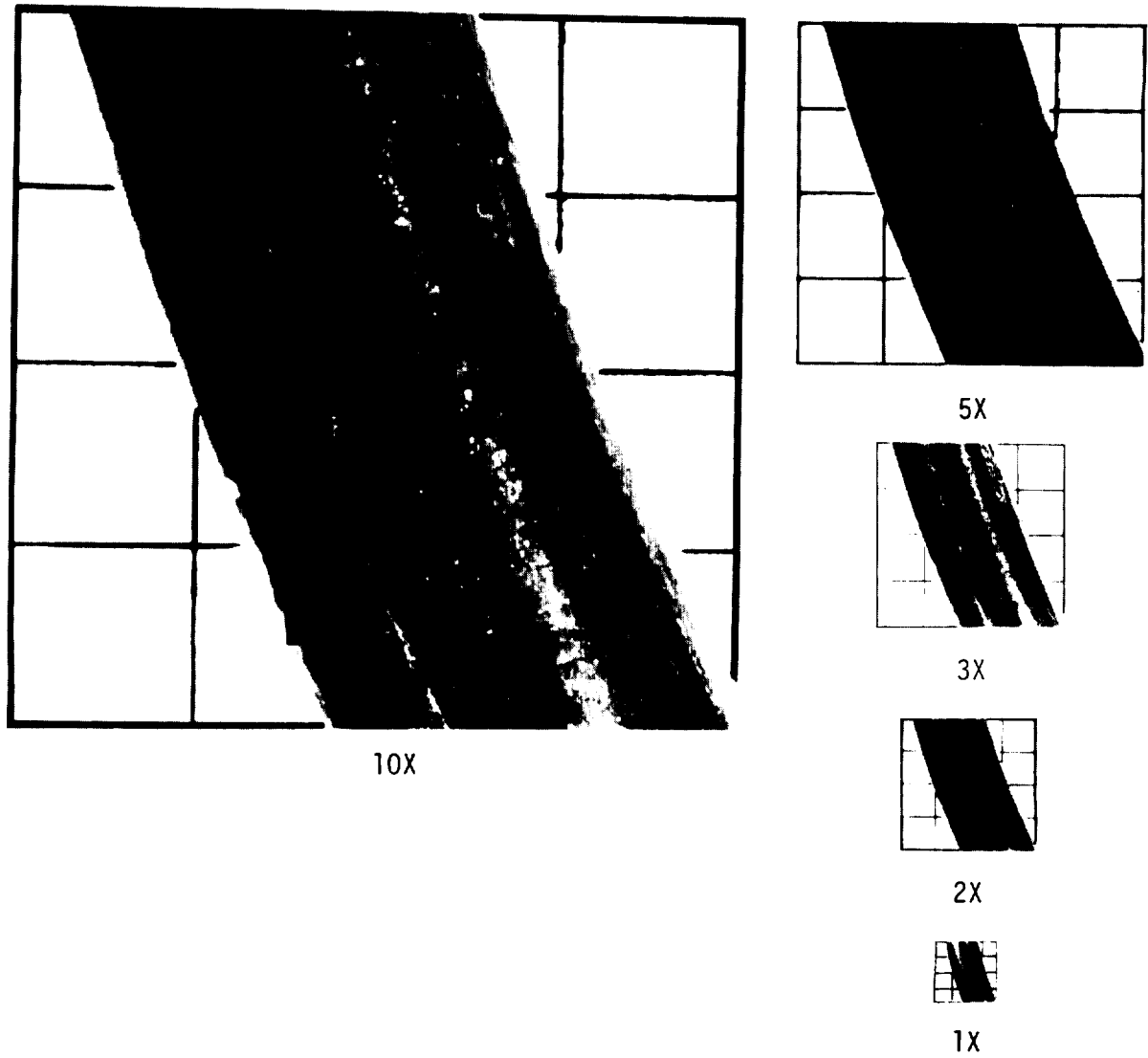

Figure 78 - Flow marks, acceptable,  
W = 0.210" (5.33 mm.)

MIL-STD-413C  
8 December 1980

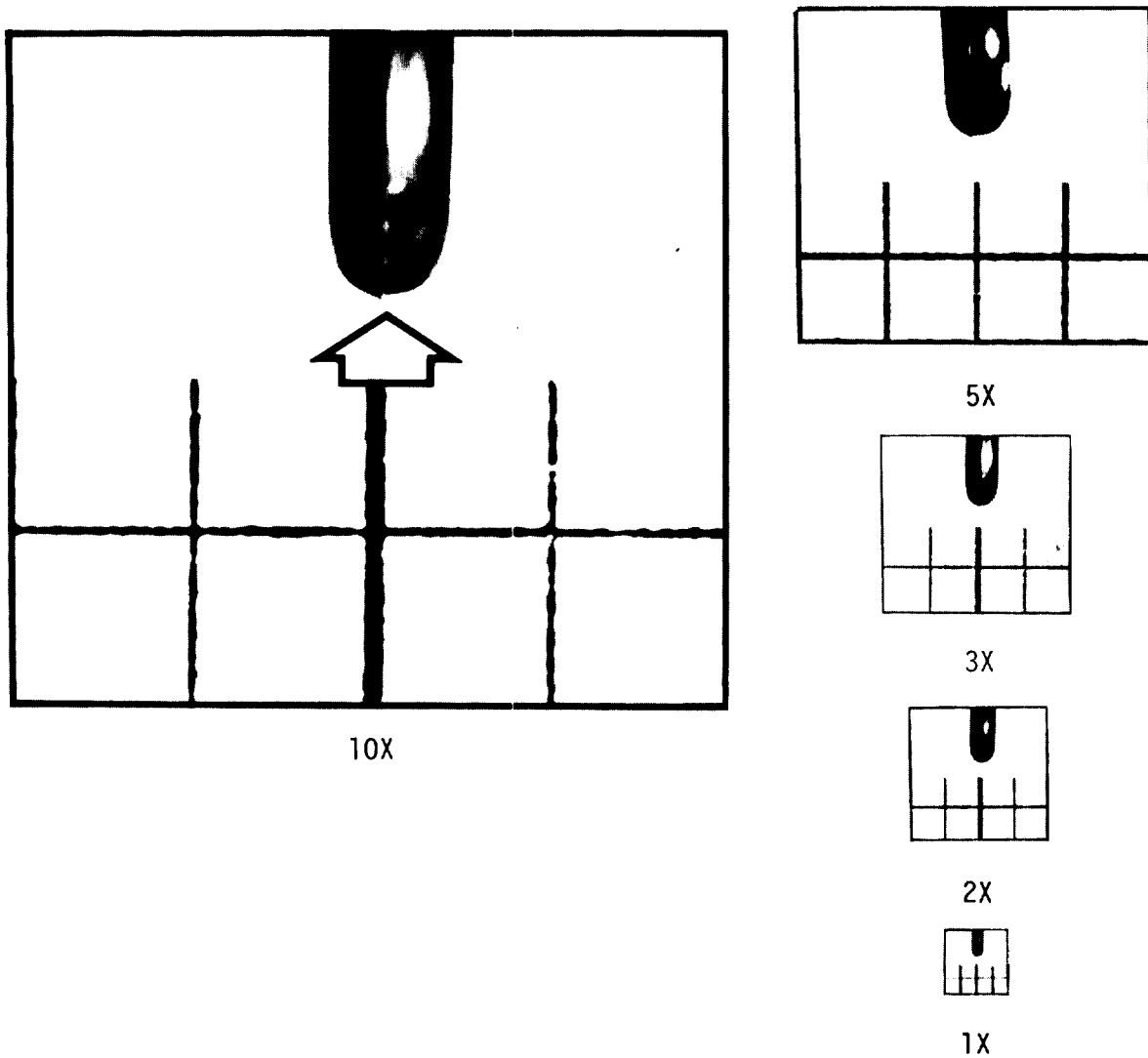

Figure 79 - Off-register and/or mismatch,  
unacceptable,  
W = 0.070" (1.78 mm.)

MIL-STD-413C  
8 December 1980

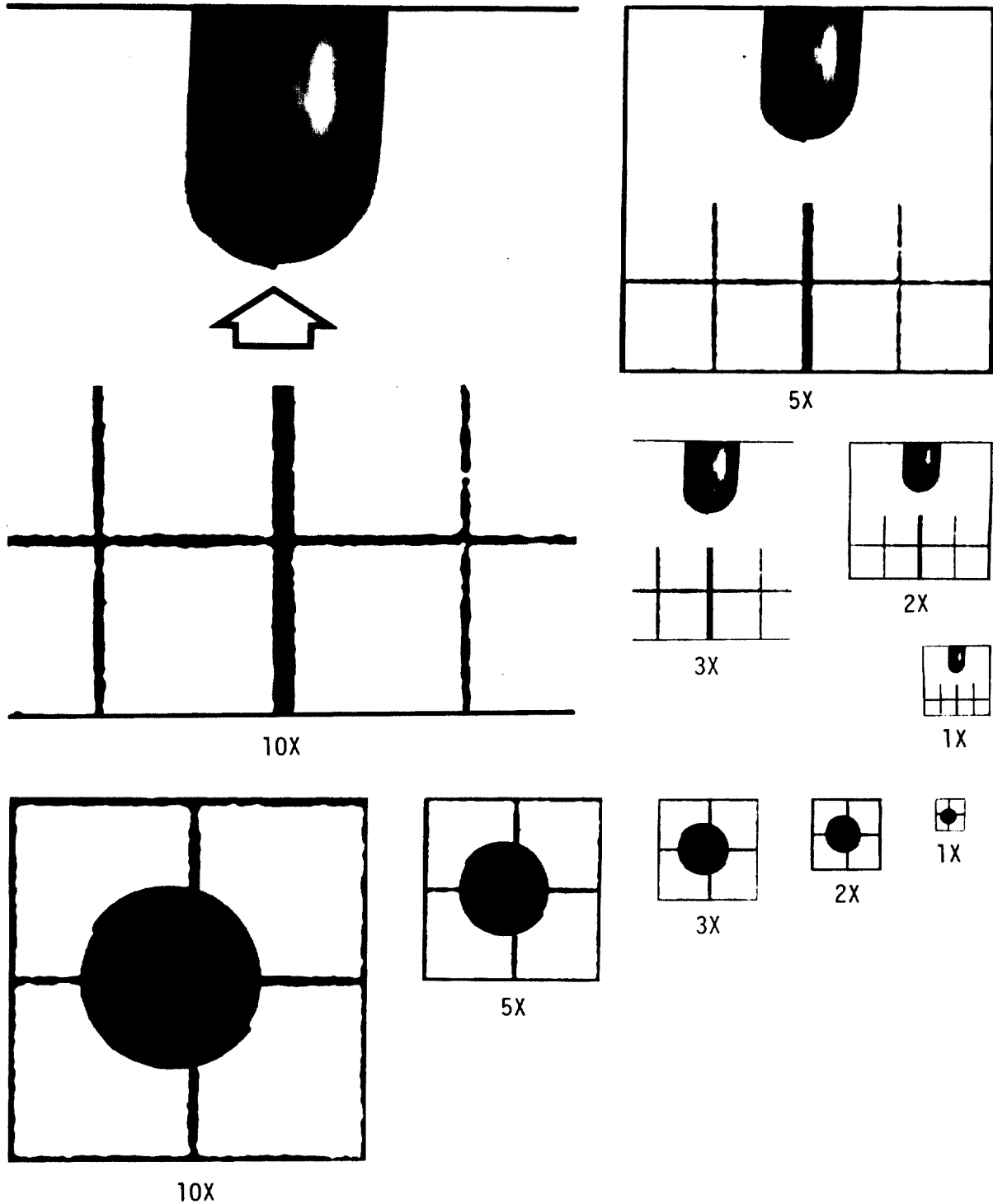

Figure 80 - Off-register and/or mismatch,  
unacceptable,  
W = 0.103" (2.62 mm.)

MIL-STD-413C  
8 December 1980

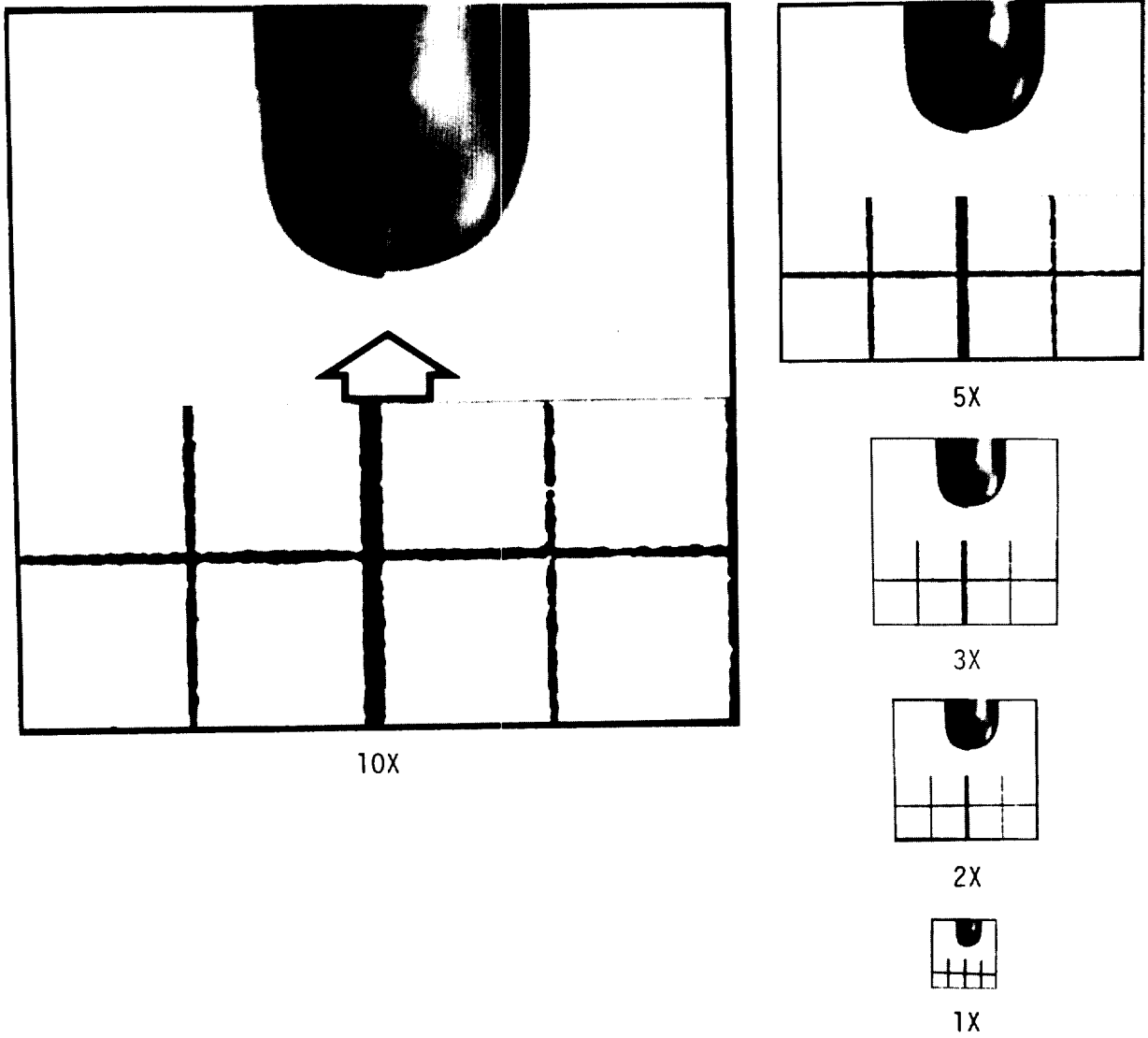

Figure 81 - Off-register and/or mismatch,  
unacceptable,  
W = 0.139" (3.53 mm.)

MIL-STD-413C  
8 December 1980

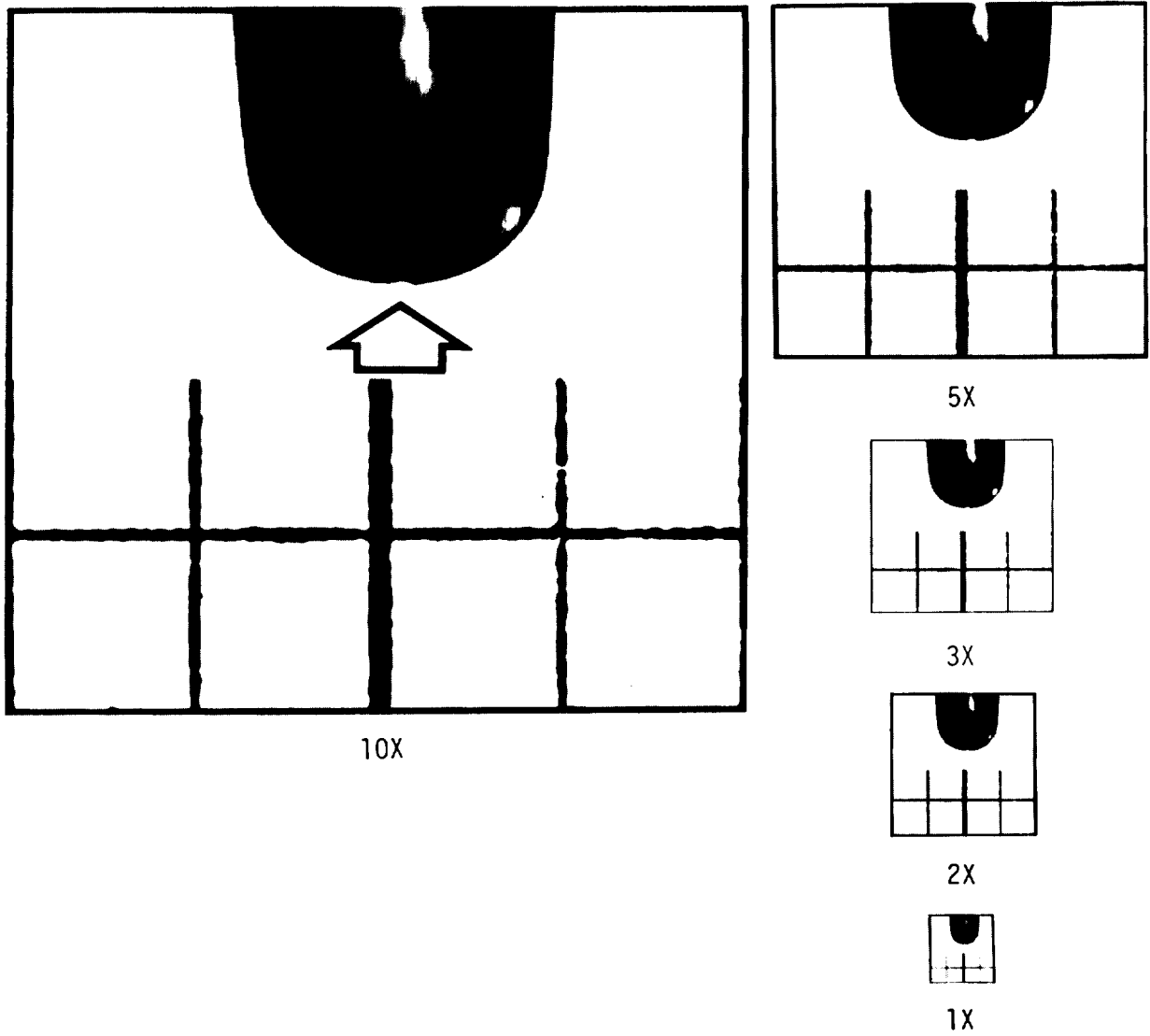

Figure 82 - Off-register and/or mismatch,  
acceptable,  
W = 0.139" (3.53 mm.)

MIL-STD-413C  
8 December 1980

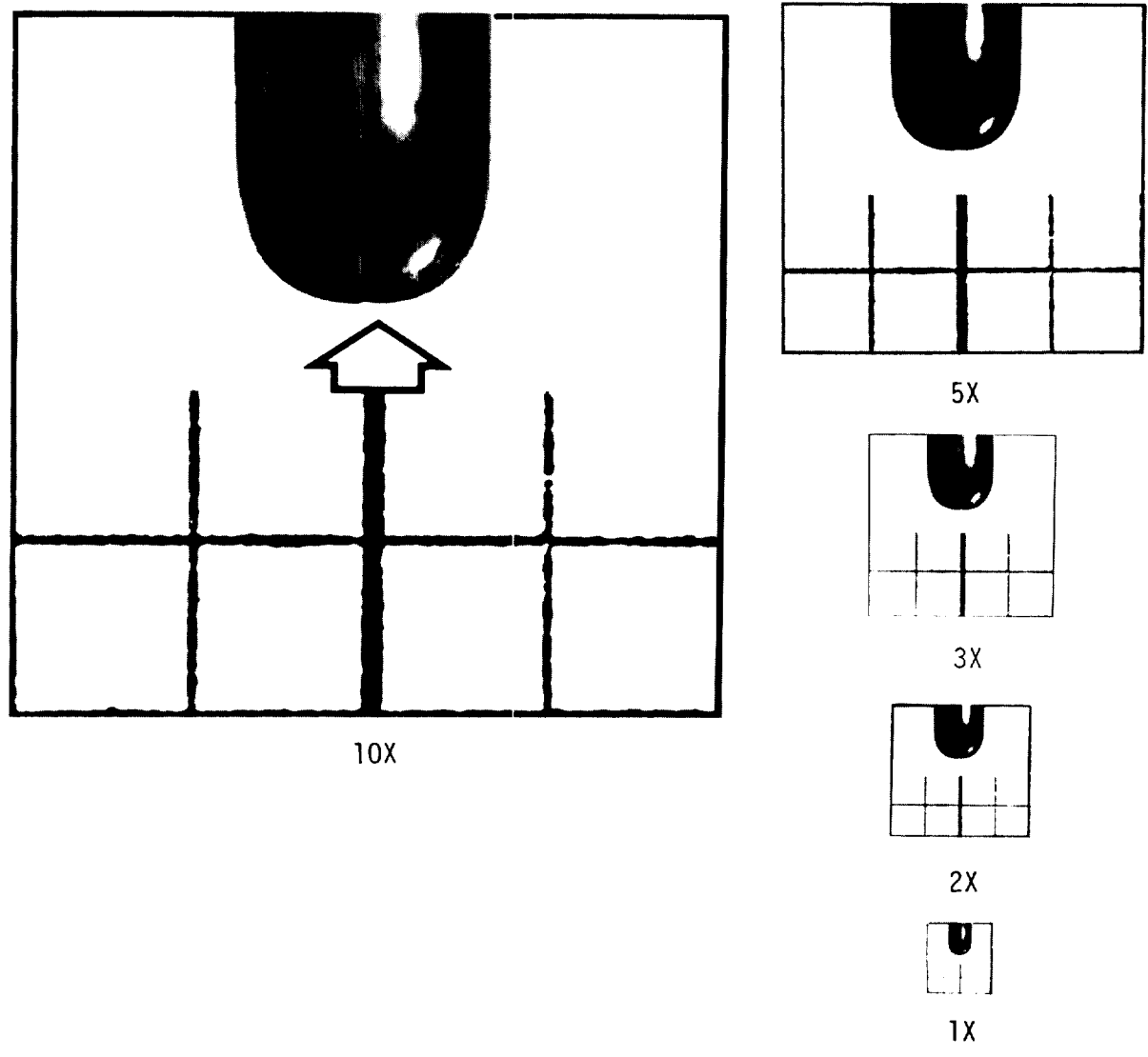

Figure 83 - Off-register and/or mismatch,  
acceptable,  
W = 0.139" (3.53 mm.)

MIL-STD-413C  
8 December 1980

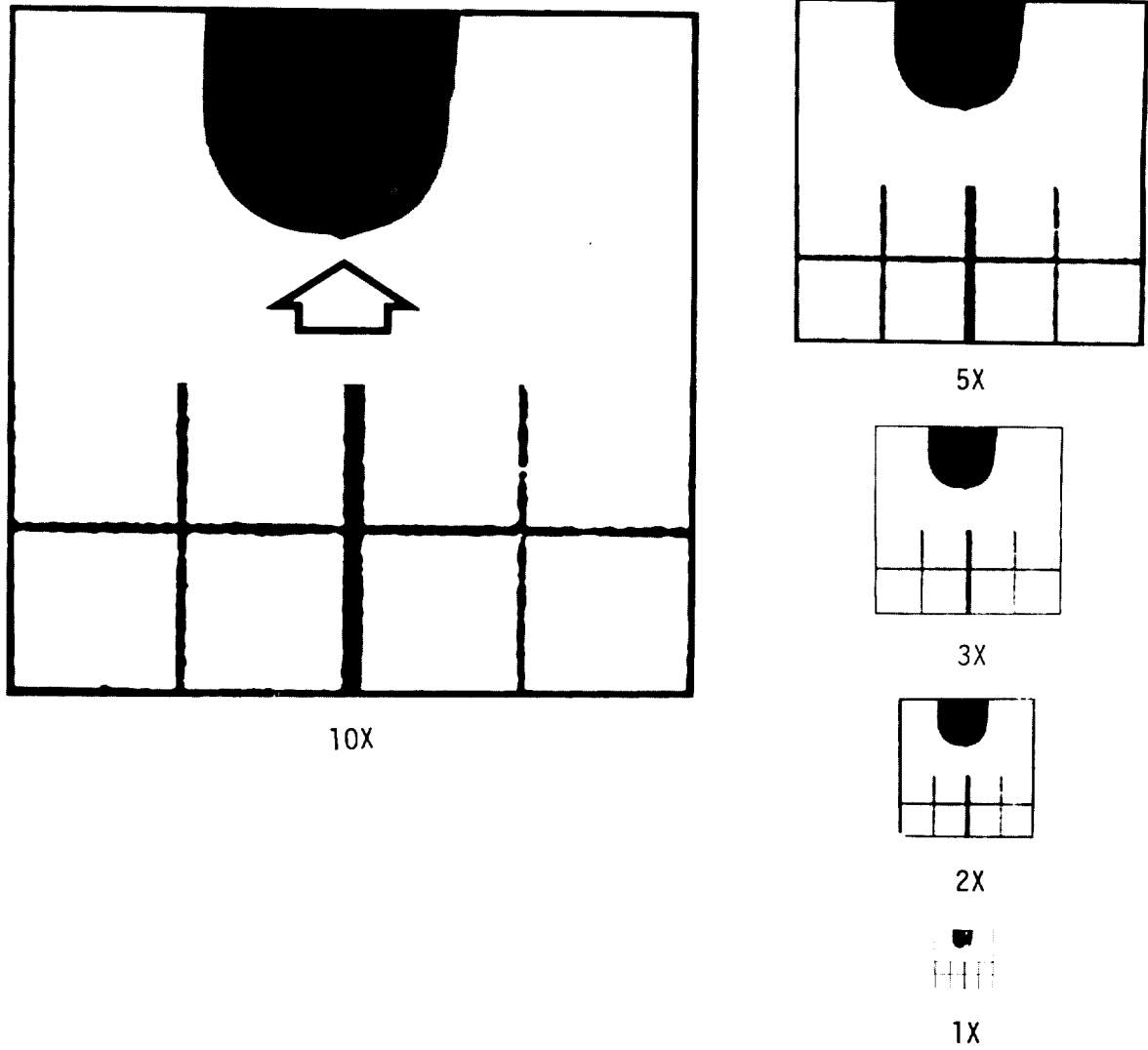

Figure 84 - Off-register and/or mismatch,  
acceptable,  
W = 0.139" (3.53 mm.)

MIL-STD-413C  
8 December 1980

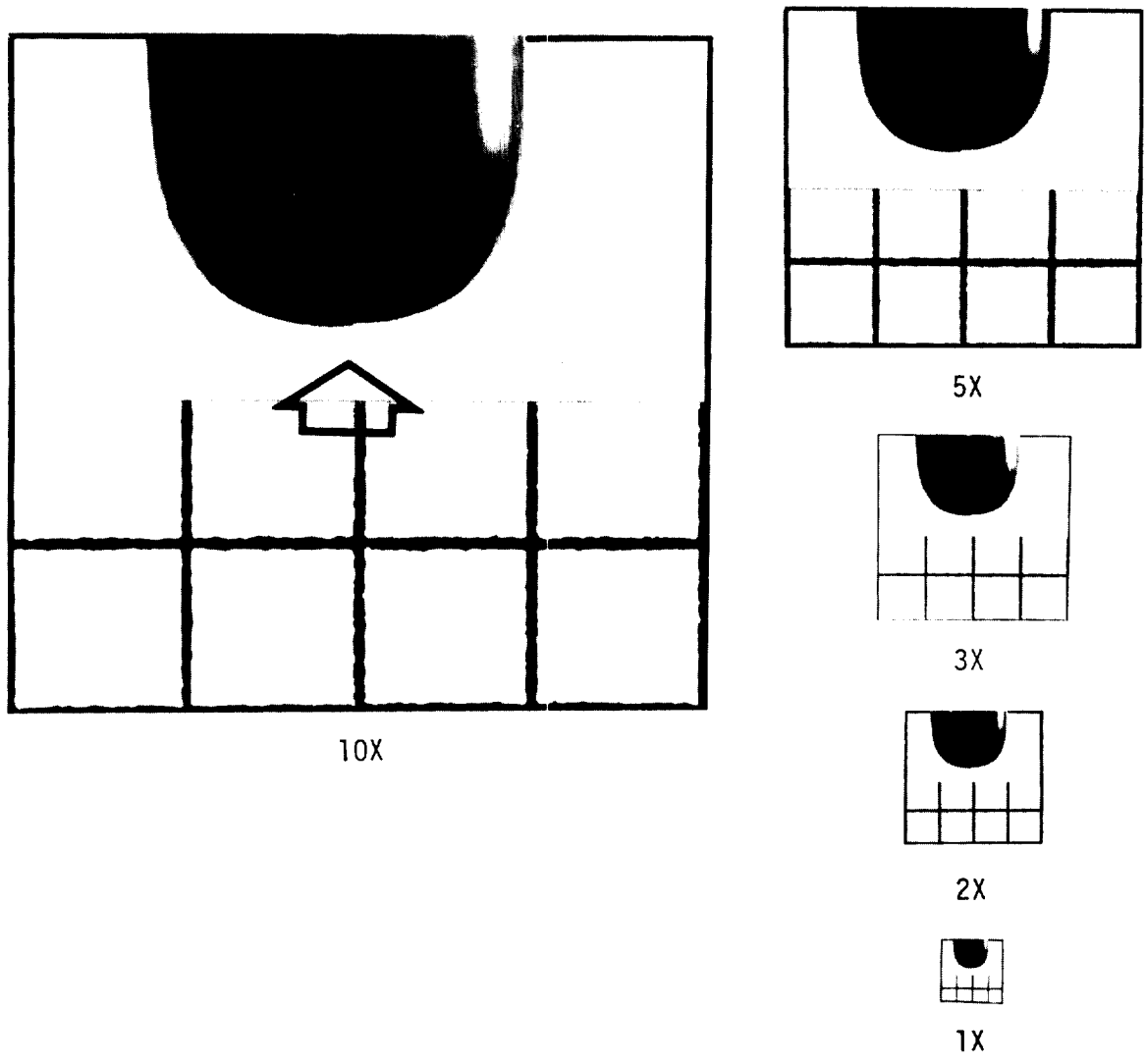

Figure 85 - Off-register and/or mismatch,  
acceptable,  
W = 0.210" (5.33 mm.)

MIL-STD-413C  
8 December 1980

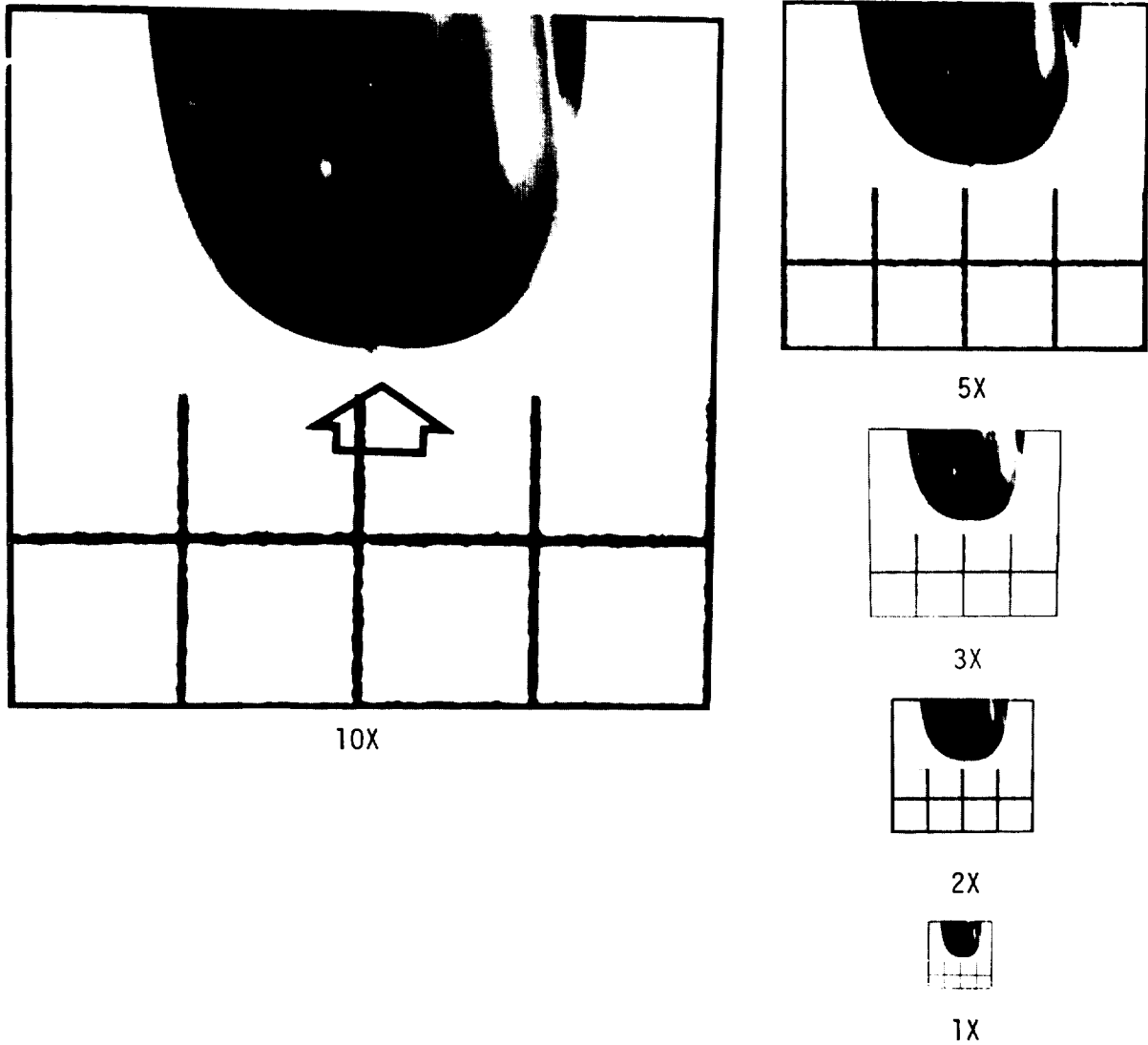
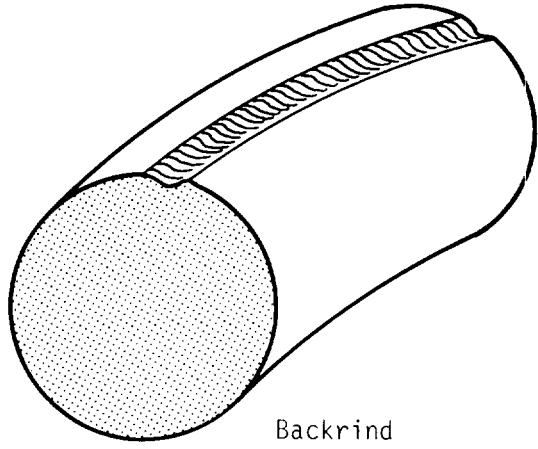
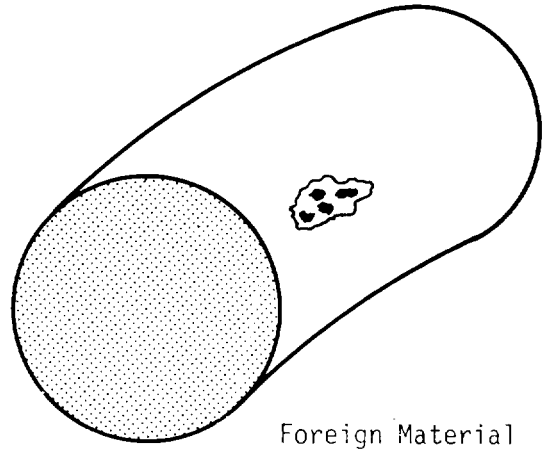

Figure 86 - Off-register and/or mismatch,  
unacceptable,  
W = 0.210" (5.33 mm.)

MIL-STD-413C  
8 December 1980



Backring



Foreign Material

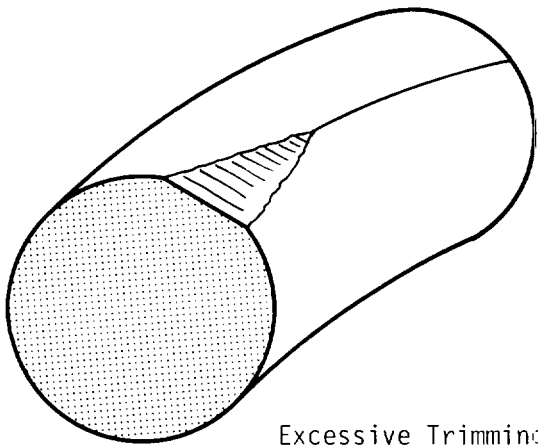

Excessive Trimming

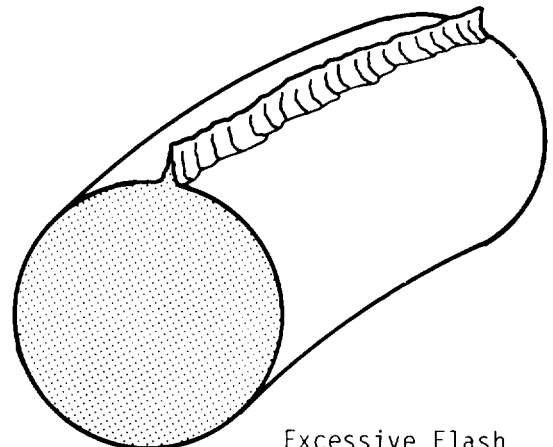

Excessive Flash  
Remaining

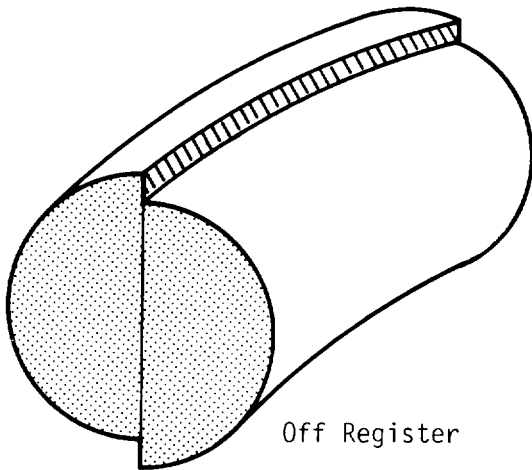

Off Register

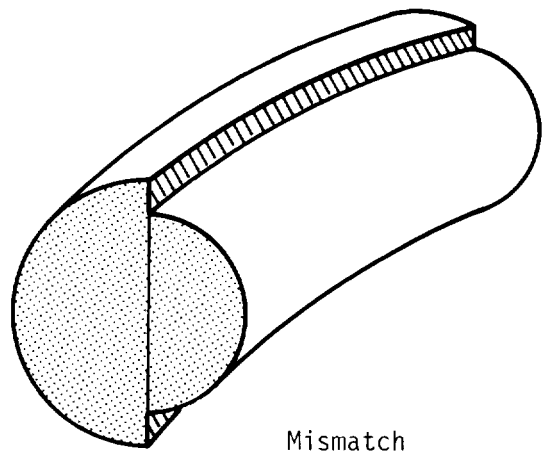

Mismatch

Figure 87 - Supplementary illustrations of surface imperfections.



| <b>STANDARDIZATION DOCUMENT IMPROVEMENT PROPOSAL</b><br><i>(See Instructions – Reverse Side)</i>  |  |
|---|--|
| <b>1. DOCUMENT NUMBER</b>   | <b>2. DOCUMENT TITLE</b>   |
| <b>3a. NAME OF SUBMITTING ORGANIZATION</b>  | <b>4. TYPE OF ORGANIZATION (Mark one)</b>  |
| <b>b. ADDRESS (Street, City, State, ZIP Code)</b>   | <input type="checkbox"/> VENDOR<br><input type="checkbox"/> USER<br><input type="checkbox"/> MANUFACTURER<br><input type="checkbox"/> OTHER (Specify): _____ |
| <b>5. PROBLEM AREAS</b>   |  |
| <b>a. Paragraph Number and Wording:</b><br><br><br><br><br><br><br><br><br><br><b>b. Recommended Wording:</b><br><br><br><br><br><br><br><br><br><br><b>c. Reason/Rationale for Recommendation:</b> |  |
| <b>6. REMARKS</b>   |  |
| <b>7a. NAME OF SUBMITTER (Last, First, MI) – Optional</b>   | <b>b. WORK TELEPHONE NUMBER (Include Area Code) – Optional</b>   |
| <b>c. MAILING ADDRESS (Street, City, State, ZIP Code) – Optional</b>  | <b>8. DATE OF SUBMISSION (YYMMDD)</b>  |