

MIL-STD-188-140A
1 MAY 1990
SUPERSEDING
MIL-STD-188-140
3 APRIL 1981

MILITARY STANDARD

EQUIPMENT TECHNICAL DESIGN STANDARDS FOR COMMON LONG HAUL/TACTICAL RADIO COMMUNICATIONS IN THE LOW FREQUENCY BAND AND LOWER FREQUENCY BANDS

AMSC N/A

AREA TCTS/SLHC

DISTRIBUTION STATEMENT A. Approved for public release; distribution is unlimited.

MIL-STD-188-140A

FOREWORD

1. This Military Standard is approved and mandatory for use by all Departments and Agencies of the Department of Defense (DOD) in accordance with DOD Directive 4640.11, dated 21 December 1987.

2. Beneficial comments (recommendations, additions, deletions) and any pertinent data which may be of use in improving this document should be addressed to: Commander Space and Naval Warfare Systems Command, Attn: Code 003-114, Washington, DC 20363-5100, by using the self-addressed Standardization Document Improvement proposal (DD Form 1426) appearing at the end of this document, or by letter.

3. Originally, Military Standard 188 (MIL-STD-188) covered technical standards for tactical and long-haul communications, but later evolved through revisions (MIL-STD-188A, MIL-STD-188B) into a document applicable to tactical communications only (MIL-STD-188C).

4. Standards for all military communications are now being published in a MIL-STD-188 series of documents. The MIL-STD-188 series is subdivided into a MIL-STD-188-100 series covering common standards for tactical and long-haul communications, a MIL-STD-188-200 series covering standards for tactical communications only, and a MIL-STD-188-300 series covering standards for long-haul communications only. Emphasis is being placed on developing common standards for tactical and long-haul communications published in the MIL-STD-188-100 series.

5. This document contains technical standards and design objectives (DOs) for minimum interface and performance standards pertinent to VLF and LF Radio Subsystems which operate in both long-haul and tactical communications systems. The terms "system standard" and "design objective" (DO) are defined in FED-STD-1037. In this document, the word "shall" identifies mandatory system standards. The word "should" identifies DOs which are desirable but not mandatory.

CONTENTS

<u>Paragraph</u>	<u>Page</u>
1. SCOPE	1
1.1 PURPOSE	1
1.2 Application	1
1.3 System standards and DO's	2
2. APPLICABLE DOCUMENTS	3
Government documents	3
Non-Government publications	4
Order of Precedence	5
3. DEFINITIONS	6
Definitions of terms	6
Acronyms and abbreviations	6
4. GENERAL REQUIREMENTS	9
4.1 Functional employment	9
4.2 Frequency band allocation	9
4.3 Radio regulations	9
4.4 Interface parameters	9
4.4.1 Digital interface characteristics	9
4.4.2 Modulation and data signaling rates	10

CONTENTS

<u>Paragraph</u>	<u>Page</u>
4.5 Electromagnetic interference (EMI) and electromagnetic compatibility (EMC) requirements	10
4.6 Grounding, bonding and shielding	10
5. DETAILED REQUIREMENTS	12
5.1 ELF band (30 Hz – 300 Hz)	12
5.2 ULF band (300 Hz – 3000 Hz)	12
5.3 VLF band (3 kHz – 30 kHz)	12
5.3.1 NATO interoperability requirements for single channel VLF	12
5.3.2 Radio frequency characteristics	12
5.3.2.1 Radio frequency tuning	12
5.3.2.2 Radio frequency stability	12
5.3.2.3 Radio frequency accuracy	13
5.3.2.4 Phase jitter	13
5.3.2.5 Radio frequency spurious emissions	13
5.3.2.6 Carrier noise level	13
5.3.2.7 Necessary bandwidth	13
5.3.3 Modulation	14

CONTENTS

<u>Paragraph</u>		<u>Page</u>
5.3.4	Amplitude frequency response	14
5.3.5	Envelope delay distortion	14
5.3.6	Interface parameters	14
5.3.7	VLF modulation rates	14
5.3.8	Modulation frequency accuracy	14
5.3.9	Precise time/time interval (PTTI) system interface	15
5.4	LF band (30 kHz – 300 kHz)	15
5.4.1	NATO interoperability requirements	15
5.4.1.1	Shore-to-ship broadcast systems	15
5.4.1.2	Maritime air communications systems	15
5.4.2	Radio frequency characteristics	15
5.4.2.1	Radio frequency tuning	15
5.4.2.2	Radio frequency stability	16
5.4.2.3	Radio frequency accuracy	16
5.4.2.4	Phase jitter	16
5.4.2.5	Radio frequency spurious emissions	16
5.4.2.6	Carrier noise level	16
5.4.2.7	Necessary bandwidth	17
5.4.3	Modulation	17
5.4.4	Amplitude frequency response	17

CONTENTS

<u>Paragraph</u>		<u>Page</u>
5.4.5	Envelope delay distortion	17
5.4.6	Interface parameters	17
5.4.7	LF modulation rates	17
5.4.8	Modulation frequency accuracy	18
5.4.9	PTTI system interface	18
6.	NOTES	18
6.1	Intended Use	18
6.2	Issue of DODISS	18
6.3	International Standardization Agreements	19
6.4	Changes from Previous Issue	19

FIGURES

Figures

1.	Radio subsystem interface points	11
A-1	PSK and FSK transitions	25
A-2	Phase continuity and discontinuity in FSK	28
A-3	CSK transitions	29
A-4	MSK modulator diagram	30

CONTENTS

<u>Paragraph</u>		<u>Page</u>
A-5	Input data timing	33
A-6	The four allowable waveforms for MSK modulation	33

Tables

A-I.	Allowable MSK output waveforms	31
A-II.	Allowable data transitions	32

APPENDICES

Paragraph

A	SOME MODULATION CHARACTERISTICS FOR THE VLF AND LF BANDS	21
10.	Scope	21
10.1	Purpose	21
10.2	Non-mandatory tutorial	21
20.	VLF and LF modulation characteristics	21
20.1	Analog modulation techniques	21
20.2	Digital modulation techniques	22
20.2.1	Interrupted continuous wave (ICW)	22

CONTENTS

APPENDICES

Paragraph

20.2.2	Continuous wave frequency shift keying (CWFSK)	22
20.3	Phase shift keying (PSK)	23
20.4	Frequency shift keying (FSK)	23
20.4.1	Phase continuity with FDK	23
20.4.2	FSK modulation index	24
20.4.3	Modulation with a modulation index of 0.5	26
20.4.3.1	Compatible shift keying (CSK)	26
20.4.3.2	Minimum shift keying (MSK)	26
20.4.3.2.1	MSK modulation	27
20.4.3.2.2	MSK derivation	30
20.4.3.2.3	MSK demodulation	34

1. SCOPE

1.1 Purpose. This standard establishes minimum performance requirements in the form of Technical Design Standards and Design Objectives (D.O.) that will ensure interoperability of future radio subsystems equipment in the VLF and LF bands. Performance requirements for experimental or developmental extremely low frequency (ELF) and ultra low frequency (ULF) are not addressed. The frequency ranges of military communications equipment have been established as a result of band characteristics which do not necessarily depend upon administrative or technical frequency band definitions. For example, in the area of the electromagnetic spectrum above ELF, that portion of application to military broadcast communications is found between 14 kHz and 200 kHz. This portion in fact extends into both the VLF and LF bands. Efficient use of the limited bandwidth available at these lower frequencies precludes most analog modulation techniques. This standard, therefore applies primarily to those radio communications equipment and systems which are involved in the transmission of single and multi-channel teletypewriter, data and facsimile information.

1.2 Application. This standard shall be used in the design and engineering of new communications equipment for both long haul and tactical systems. Reference is made, in some cases, to other documents which provide standards for specific applications. It is not intended that existing systems be immediately converted in compliance with the requirements of this standard. New systems and those undergoing major modification or rehabilitation shall conform to these standards, subject to the provisions of current procurement regulations. Modulation techniques

are not standardized in this document. However, radio subsystems covered by this standard shall be interoperable using any of the modulation methods outlined in Appendix A.

1.3 System standards and DO's. Mandatory equipment parameters or requirements within the context of DOD 4640.11 of 21 December 1987 are identified through the use of the word "shall". Desirable or recommended DO's are indicated within parentheses after a mandatory parameter value or by use of the word "should".

2. APPLICABLE DOCUMENTS

2.1 Government documents.

2.1.1 Specifications, standards and handbooks. The following specifications, standards, and handbooks form a part of this document to the extent specified herein. Unless otherwise specified, the issues of these documents are those listed in the issue of the Department of Defense Index of Specifications and Standards (DODISS) and supplement thereto, cited in the solicitation (see 6.2).

STANDARDS

FEDERAL

FED-STD-1037

Glossary of Telecommunications Terms.

DOD-STD-1399/441

Interface Standard for Shipboard Systems Section 441 Precise Time and Time Interval (PTTI).

DODISS

Department of Defense Index of Specifications and Standards

MILITARY

MIL-STD-463A

Definitions and System of Units, Electromagnetic Interface and Electromagnetic Compatibility Technology.

MIL-STD-188-100

Common Long Haul and Tactical Military Communications System Technical Standards.

MIL-STD-188-114

Electrical Characteristics of Digital Interface Circuits.

MIL-STD-188-124	Grounding, Bonding and Shielding for Common Long Haul/Tactical Communications Systems.
MIL-STD-188-461	Electromagnetic Emission and Susceptibility Requirements for the Control of Electromagnetic Interference.
MIL-STD-462	Electromagnetic Interference Characteristics, Measurement of.

(Copies of specifications, standards, drawings, and publications required by contractors in connection with specific procurement functions should be obtained from the procuring activity or as directed by the contracting officer).

2.2 Non-Government publications. The following documents form a part of this document to the extent specified herein. Unless otherwise specified, the issues of the documents, which are DoD adopted are those listed in the issue of the DODISS cited in the solicitation. Unless otherwise specified, the issues of documents not listed in the DODISS are the issues of the documents cited in the solicitation (see 6.2).

North Atlantic Treaty Organization Standardization Agreements (STANAG's)

STANAG 4335	Technical Standards for Single Channel LF Radio Equipment.
STANAG 5026	Military Characteristics for Analogue Facsimile Equipment to Meet Meteorological Requirements.
STANAG 5030	Single and Multi-Channel VLF and LF On-Line Broadcast and Off-Line 00K Systems.

STANAG 5031

Introduction of Modern Radio Equipment for Naval HF-MF and LF Shore-to-Ship Broadcasts.

STANAG 5035

Introduction of an Improved System for Maritime Air Communications on HF, LF and UHF.

(Copies of STANAGs required by suppliers in connection with specific procurement functions should be obtained from the procuring activity or as directed by the contracting officer).

INTERNATIONAL REGULATIONS

**General Secretariat of the
International
Telecommunication
Union, Geneva**

Radio Regulations

(Available from the International telecommunication Union, Place Des Nations, 1211 Geneva - 20, Switzerland.

2.3 Order of precedence. In the event of a conflict between the text of this document and the references cited herein, the text of this document takes precedence. Nothing in this document, however, supersedes applicable laws and regulations unless a specific exemption has been obtained.

3. DEFINITIONS

3.1 Definitions of terms. Definitions of terms used in this standard are as specified in FED-STD-1037 and ITU radio regulations, article one, or as defined in appendix A. For purposes of this standard, definitions are provided for the following terms, some of which are repeated from ITU radio regulations and FED-STD-1037 for convenience and clarification.

Single sideband. An amplitude modulated emission with one sideband only.

Out-of-band emission. Emission on a frequency or frequencies immediately outside the necessary bandwidth which results from the modulation process, but excluding spurious emissions. (See also necessary bandwidth).

Spurious emission. Emission on a frequency or frequencies which are outside the necessary bandwidth and the level of which may be reduced without affecting the corresponding transmission of information. Spurious emissions include harmonic emissions, parasitic emissions, intermodulation products and frequency conversion products, but exclude out-of-band emissions.

Unwanted emissions. Consist of spurious emissions and out of band emissions.

Minimum shift keying (MSK). MSK is a unique modulation technique which results in an FSK type of waveform with a modulation index of 0.5 vice the common FSK modulation index of 1.0.

3.2 Acronyms and abbreviations. Acronyms and abbreviations used in this document are defined below. Those that are also found in FED-STD-1037 have been included for convenience.

AM	Amplitude Modulation
ASCII	American Standard Code for Information Interchange (also known as USASCII)
Bd	Baud
B/s	Bits per second
CSK	Compatible Shift Keying
CTFS	Central Time and Frequency System
CWFSK	Continuous Wave Frequency Shift Keying
DoD	Department of Defense
DO	Design Objective
ELF	Extremely Low Frequency (30 Hz – 300 Hz)
EMI	Electromagnetic Interference
EMC	Electromagnetic Compatibility
FDM	Frequency Division Multiplex
FSK	Frequency Shift Keying
ICW	Interrupted Continuous Wave
IRAC	Interdepartment Radio Advisory Committee
ITU	International Telecommunication Union
JCS	Joint Chiefs of Staff
LF	Low Frequency (30 kHz – 300 kHz)
MCEB	Military Communication Electronics Board
MF	Medium Frequency (0.3 MHz – 3.0 MHz)
MSK	Minimum Shift Keying
NATO	North Atlantic Treaty Organization
NAVOBSY	U.S. Naval Observatory
PSK	Phase Shift Keying
PTTI	Precise Time/Time Interval

RATT	Radio Teletype
SLHC	Standards for Long-Haul Communications (DoD Standardization Area)
SNR	Signal to Noise Ratio
SSB	Single Sideband
STANAG	NATO Standardization Agreement
TCTS	Tactical Communications Systems Technical Standards (DOD Standardization Area)
TWX	Teletypewriter Exchange Service
ULF	Ultra Low Frequency (300 Hz – 3000 Hz)
VFTG	Voice Frequency Telegraph
VLF	Very Low Frequency (3 kHz – 30 kHz)
WARC	World Administrative Radio Conference

4. GENERAL REQUIREMENTS

4.1 Functional employment. The radio equipments are employed in long haul and tactical communication systems and subsystems. The delineation between long haul and tactical communication systems can be found in FED-STD-1037. These systems provide communication service in the functional areas of command and control, logistics, intelligence, weather and administration. Traffic may be in one or more of the following forms: graphics, teletypewriter and data which may be transmitted as quasi-analog or digital signals.

4.2 Frequency band allocation. Section 5 specifies standards and DO's for radio equipment according to frequency band allocation.

4.3 Radio regulations. For subsystem and equipment design, the choice and performance of the equipment, as well as frequencies and emissions of any radio subsystem, shall comply with the applicable requirements of the current edition of the International Telecommunication Union (ITU) Radio Regulations. Adequate familiarity with these regulations is, therefore, required of designers and users of radio subsystems. Final approval of frequency bands, operating modes, and equipment characteristics rests within DOD with the Military Communications - Electronics Board (MCEB).

4.4 Interface parameters.

4.4.1 Digital interface characteristics. All digital interfaces between and among equipments where the information being conveyed is in the form of binary signals at the direct current (DC) baseband level shall comply with the applicable requirements of the current edition of MIL-STD-188-114. See FIGURE 1.

NOTE: Radio regulations information. The use of the frequency spectrum is regulated by international agreements embodied in the Radio Regulations,

published by the General Secretariat of the ITU, Geneva, Switzerland, and modified periodically by a World Administrative Radio Conference (WARC). These radio regulations are further qualified at the national level through Federal Government agencies, such as the Department of Commerce, the Interdepartment Radio Advisory Committee (IRAC), and through military agencies, such as the Joint Chiefs of Staff (JCS) and the MCEB. Military frequency planning, including joint functional frequency allocation tables, is established as a joint action area under the MCEB.

4.4.2 Modulation and data signaling rates. The modulation rates (expressed in bauds (Bd)) and the data signaling rates (expressed in bits per second (B/s)) at interface POINTS "A" of FIGURE 1 shall be those contained in the Modulation and Data Signaling Rates paragraph of MIL-STD-188-100 except that the modulation rates and data signaling rates above 9600 Bds or B/s shall not apply.

4.5 Electromagnetic interference (EMI) and electromagnetic compatibility (EMC) requirements. Equipments shall meet the applicable EMI and EMC requirements of MIL-STD-461 which shall be specified in the equipment specification.

4.6 Grounding, bonding and shielding. Grounding, bonding and shielding for VLF and LF bands shall conform to the applicable requirements of the current edition of MIL-STD-188-124.

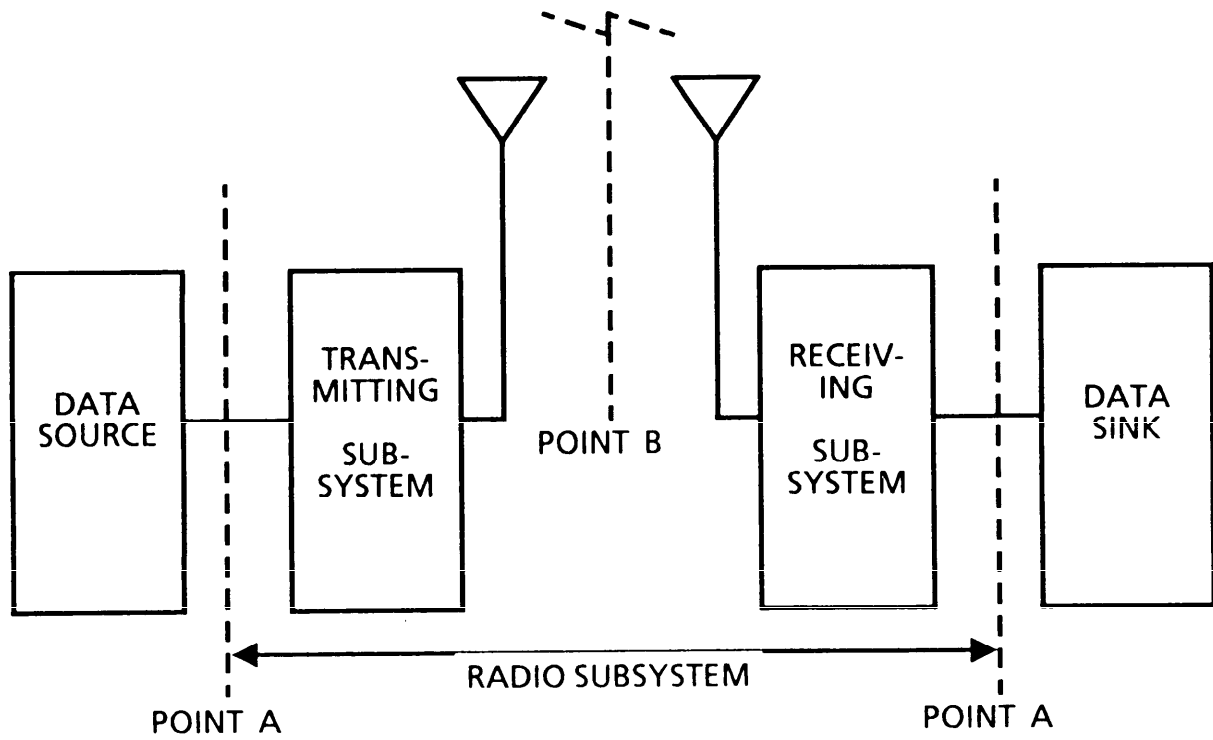

FIGURE 1. Radio subsystem interface points

5. DETAILED REQUIREMENTS

5.1 ELF band (30 Hz – 300 Hz). Employment of this band is developmental or experimental and is not addressed.

5.2 ULF band (300 Hz – 3000 Hz) Employment of this band is developmental or experimental and is not addressed.

5.3 VLF band (3 kHz – 30 kHz). The VLF band is employed primarily for broadcast in the maritime and aeronautical mobile services and for limited long haul communications. Some military equipment in this field is designed to operate in both the VLF and the LF bands.

5.3.1 NATO interoperability requirements for single and multi-channel VLF and LF. For interoperation with NATO member nations, single and multi-channel VLF and LF on-line broadcast systems shall conform to the applicable requirements of the current edition of STANAG 5030.

5.3.2 Radio frequency characteristics.

5.3.2.1 Radio frequency tuning. VLF radio equipments shall be capable of being tuned and aligned, over the frequency range of the equipment, at integral multiples of ten Hz increments even though the carrier (or center) frequency may be assigned differently.

5.3.2.2 Radio frequency stability. The frequency stability of the VLF radio equipment, with respect to the initial frequency after calibration shall be no less than 1 part in 10^9 per day for the first 30 days and 2 parts in 10^8 for each 30-day period thereafter.

5.3.2.3 Radio frequency accuracy. VLF radio equipment shall be capable of a frequency accuracy no less than 1 part in the 10^9 of any designated frequency within the frequency range of the equipment.

5.3.2.4 Phase jitter. The maximum phase jitter of individual VLF transmitting and receiving equipment averaged over a period equal to two times the reciprocal of the modulation rate shall not exceed 3 degrees for systems using coherent demodulation and 15 degrees for systems using non-coherent demodulation. Measurement shall be performed for at least 100 sample time periods.

5.3.2.5 Radio frequency spurious emissions. The spurious RF emissions of VLF radio transmitting equipment shall comply with the applicable requirements of ITU Radio Regulations.

5.3.2.6 Carrier noise level. The carrier noise level of VLF transmitting equipment shall be at least 50 decibels (dB) (DO: 60 dB) below the unmodulated or continuous wave (cw) carrier level at full rated output power. This measurement shall be made at the RF output of the transmitter under operational or simulated operational conditions which must be specified in the equipment specification.

5.3.2.7 Necessary bandwidth. The necessary bandwidth of VLF radio equipment in hertz shall not exceed 2.4 times the modulation rate in bauds for a modulation index of 1.0 or shall not exceed 1.2 times the modulation rate in bauds for a modulation index of 0.5.

5.3.3 Modulation. Modulation techniques for the VLF band are not standardized in this document. However, modulation techniques shall be selected carefully to meet all system interoperability requirements. Examples of some current modulation techniques are given in APPENDIX A.

5.3.4 Amplitude frequency response. The maximum to minimum amplitude frequency response of VLF radio transmitting and receiving equipment, measured individually, over the necessary bandwidth for each, shall not exceed 1 dB.

5.3.5 Envelope delay distortion. The envelope delay distortion of VLF radio transmitting and receiving equipment, measured individually, shall not exceed 50 microseconds (usec) over the necessary bandwidth.

5.3.6 Interface parameters. See 4.4.

5.3.7 VLF modulation rates. The modulation rates for VLF radio equipment at the interface POINTS "A" of FIGURE 1 shall be selected from the following, as applicable:

- a. 5 Bd
- b. 50×2^n Bd ($n = 0, 1, 2, 3 \dots 7$)
- c. 75×2^n Bd ($n = 0, 1, 2, 3 \dots 7$)

5.3.8 Modulation frequency accuracy. Modulation frequency accuracies shall be as follows:

- a. For VLF radio equipment using coherent demodulation, the modulation frequency accuracies shall correspond to the RF accuracy tolerances of 5.3.2.3.

- b. For VLF radio equipment using non-coherent demodulation, the tolerance of the MARK or SPACE frequencies shall not exceed ± 2 percent of the frequency shift.

5.3.9 Precise time/time interval (PTTI) system interface. For those equipments requiring a PTTI Interface, DOD-STD-1399, Navy Section 441 shall be cited.

5.4 LF band (30 kHz – 300 kHz). The LF band is employed primarily for broadcast in the maritime and aeronautical mobile services and for limited long haul communications. Some military equipment in this field is designed to operate in both the VLF and the LF bands.

5.4.1 NATO interoperability requirements.

5.4.1.1 Shore-to-ship broadcast systems. For interoperation with NATO member nations, LF shore-to-ship broadcast systems shall comply with the applicable requirements of the current edition of STANAGs 4335 and 5031.

5.4.1.2 Maritime air communications systems. For interoperations with NATO member nations, LF maritime air communication systems shall comply with applicable requirements of the current edition of STANAG 5035.

5.4.2 Radio frequency characteristics.

5.4.2.1 Radio frequency tuning. LF radio equipment shall be capable of being tuned and aligned, over the frequency range of the equipment, in integral multiples of ten Hz increments even though the carrier (or center) frequency may be assigned differently.

5.4.2.2 Radio frequency stability. The frequency stability of the LF radio equipment, with respect to the initial frequency after calibration, shall be no less than 1 part in 10^9 per day for the first 30 days and 2 parts in 10^8 for each 30-day period thereafter.

5.4.2.3 Radio frequency accuracy. LF radio equipment shall be capable of a frequency accuracy no less than 1 part in 10^9 of any designated frequency within the frequency range of the equipment.

5.4.2.4 Phase jitter. The maximum phase jitter of individual LF radio transmitting and receiving equipment averaged over a period equal to two times the reciprocal of the modulation rate shall not exceed 3 degrees for systems using coherent demodulation and 15 degrees for systems using non-coherent demodulation. Measurement shall be performed for at least 100 sample time periods.

5.4.2.5 Radio frequency spurious emissions. The spurious RF emission of LF radio transmitting equipment shall comply with the applicable requirements of ITU Radio Regulations.

5.4.2.6 Carrier noise level. The carrier noise level of LF transmitting equipment shall be at least 50 dB (DO: 60 dB) below the unmodulated or cw carrier level at full rated output power. This measurement shall be made at the RF output of the transmitter under operational or simulated conditions which must be specified in the equipment specification.

5.4.2.7 Necessary bandwidth. The necessary bandwidth of LF radio equipment in hertz shall not exceed 2.4 times the modulation rate in bauds for a modulation index of 1.0 or shall not exceed 1.2 times the modulation rate in bauds for a modulation index of 0.5.

5.4.3 Modulation. Modulation techniques for the LF band are not standardized in this document. However, modulation techniques shall be selected carefully to meet all system interoperability requirements. Examples of current modulation techniques are given in APPENDIX A.

5.4.4 Amplitude frequency response. The maximum to minimum amplitude frequency response for LF radio transmitting and receiving equipment, measured individually, over the necessary bandwidth for each, shall not exceed 1.5 dB.

5.4.5 Envelope delay distortion. The envelope delay distortion of LF radio transmitting and receiving equipment, measured individually, shall not exceed 50 microseconds (usecs) over the necessary bandwidth.

5.4.6 Interface parameters. See 4.4

5.4.7 LF modulation rates. The modulation rates for LF radio equipment at the interface POINT A of Figure 1 shall be selected from the following, as applicable:

- a. 5 Bd
- b. 50×2^n Bd ($n = 0, 1, 2, 3 \dots 7$)
- c. 75×2^n Bd ($n = 0, 1, 2, 3 \dots 7$)

5.4.8 Modulation frequency accuracy.

- a. For LF radio equipment using coherent demodulation, the modulation frequency accuracies shall correspond to the RF accuracy tolerances of 5.4.2.3.

- b. For LF radio equipment using non-coherent demodulation the tolerance of the MARK or SPACE frequencies shall not exceed ± 2 percent of the frequency shift.

5.4.9 PTTI systems interface. For those equipments requiring a PTTI interface, DOD-STD-1399, Navy Section 441 shall be cited.

6. NOTES (This section contains information of general or explanatory nature that may be helpful, but is not mandatory.)

6.1 Intended Use. This standard contains requirements to ensure interoperability and minimum performance of new VLF and LF radio subsystems. These subsystems are intended for use in tactical and long-haul, shore-to-ship, point-to-point, ground-air-ground and air to ship communication of single and multi-channel teletypewriter, data and facsimile information. This standard is not intended for use in specifications for VLF or LF time standards, navigation systems, special purpose integrated communication systems or terminal equipment external to interface A in FIGURE 1. However, technical design standards for special purpose communication systems should not be less than specified herein without an exemption.

6.2 Issue of DODISS. When this standard is used in acquisition, the applicable issue of the DODISS must be cited in the solicitation (see 2.1 and 2.2).

6.3 International standardization agreements. Certain provisions of this document (see 4.3, 5.3.1 and 5.4.1) are the subject of international standardization agreements STANAG 4335, STANAG 5026, STANAG 5030, STANAG 5031 and STANAG 5035.

6.4 Changes from previous issue. Marginal notations are not used in this revision with respect to the previous issue due to the extensiveness of the format changes. The technical standards are essentially unchanged.

CONCLUDING MATERIAL

Custodians:

Army – CR

Navy – EC

Air Force – 17

Preparing activity:

NAVY-EC

(Project TCTS 1400)

Review activities:

Army – SC

Other interest:

JCS – J6

User activities:

Army –

Navy – AS, MC

Air Force –

MIL-STD-188-140A

APPENDIX A

SOME MODULATION CHARACTERISTICS FOR THE VLF AND LF BANDS

10. SCOPE

10.1 Purpose. This appendix describes some characteristics of modulation techniques used in the VLF and LF bands which are uncommon in higher frequency bands.

10.2 This appendix contains non-mandatory tutorial information.

20. VLF and LF modulation characteristics. VLF and LF shore based communications transmitting systems are characterized by narrow RF bandwidths (less than conventional voice channels) and higher power transmitters. Narrow bandwidths are the result of the fact that the antennas used at these frequencies are electrically very short even though they are often physically large. The antenna size versus wavelength results in a highly reactive antenna impedance with a low resistance (High Q) and consequently limited bandwidth and long charge/discharge time constant. High power radio transmitters are used because of the low radiation efficiency of the antenna, the need for long-range radio communications, and significant sea water attenuation for communications with submerged submarines. Both the necessity to operate to the limits of the bandwidth normally available and the high transmitting power involved place stringent requirements on the modulation techniques used.

20.1 Analog modulation techniques. Conventional analog amplitude modulation (AM) and frequency modulation (FM) are not widely used at VLF or LF

because of their inefficient use of the available limited RF bandwidth. Amplitude modulation (single sideband) is used for frequency division multiplex (FDM) multichannel voice frequency telegraph (VFTG) and facsimile LF shore to ship broadcasts.

20.2 Digital modulation techniques. Modulation techniques for VLF and LF are mostly restricted to digital means because of limited system bandwidth. Additionally, the bandwidth restriction is such that the digital technique selected should be the most efficient in its use of bandwidth if a usable level of traffic throughput is to be attained. The principal digital modulation techniques are described in the following, with greater emphasis and detail on those in current use which yield the best operational capabilities.

20.2.1 Interrupted continuous wave (ICW). ICW or on-off keying (usually associated with international Morse Code) can be used with VLF and LF systems, but is presently used only as a back-up. In the case of fixed shore base installations, ICW data rates are severely limited by the time constant of the antenna circuit. Airborne transmitters, which have greater RF bandwidths because of their long trailing wire antennas, are still restricted from ICW use because of the resulting power supply surges which cannot be accommodated by aircraft generating systems operating near power supply limits and having little power supply inertial energy storage.

20.2.2 Continuous wave frequency shift keying (CWFSK) CWFSK is used as a back-up in airborne systems to take the place of ICW for transmitting Morse Code. CWFSK avoids power supply surges by transmitting a second tone to represent the off periods. It is a special case of FSK in which the SPACE frequency is separated from the MARK frequency by a large frequency separation (normally 200Hz). This

separation allows the receiver to filter out the SPACE frequency to receive only the MARK frequency, resulting in ICW reception. CWFSK can be coherently detected with a resulting substantial increase in signal-to-noise ratio (SNR).

20.3 Phase shift keying (PSK). PSK provides the most efficient use of RF bandwidth but is not presently used at VLF/LF because of the transients caused by phase discontinuities. If the conventional phase-reversal PSK is used (see FIGURE A-1), these transients, which will be generated at the MARK/SPACE and SPACE/MARK transitions, can result in damage to the high power transmitter final amplifiers or cause a transmitter outage (kickdown).

20.4 Frequency shift keying (FSK). Except for the back-up use of ICW and CWFSK, FSK and modulation techniques which result in an FSK type of spectrum are the major ones used at VLF and LF. The phase discontinuity restrictions described in 20.3 apply as well to FSK and special techniques are employed to bring them within limits.

20.4.1 Phase continuity with FSK. The term phase continuity is used for the modulation process in lieu of phase coherency which is more often associated with the demodulation process.

In FSK there are distinct SPACE (f_s) and MARK (f_m) frequencies which can be generated separately or obtained from the sidebands of tone modulated carrier. In neither case is the center frequency transmitted. The difference between the frequencies ($f_s - f_m$) is the total carrier shift. An FSK modulator must abruptly shift from SPACE to MARK frequencies (and vice versa) in accordance with the information code (data stream) and, in the present case, must accomplish this shift

without an excessive discontinuity in phase. FIGURE A-1 shows both a phase continuous and a phase discontinuous FSK transition.

FIGURE A-2 further addresses the phase continuity/discontinuity phenomena in FSK.

20.4.2 FSK modulation index. The modulation index (M) is defined as the carrier frequency shift ($f_s - f_m$) divided by the modulation rate (in bits per second (bit/sec)). It can be seen in FIGURE A-2 that if the SPACE/MARK transitions are to be synchronized with the 0 degree to 360 degree crossing, the modulation rate (or transmitted signaling rate) must have a strict relationship to the total carrier frequency shift (or difference frequency), that is, for FSK with acceptable phase continuity: (a) The modulation index must be an integer; and (b) The relative phase of f_s and f_m must be the same at the instant of transition. The requirement to make the best possible use of bandwidth in VLF and LF results in the minimum modulation index of 1.0 being used for FSK in those bands.

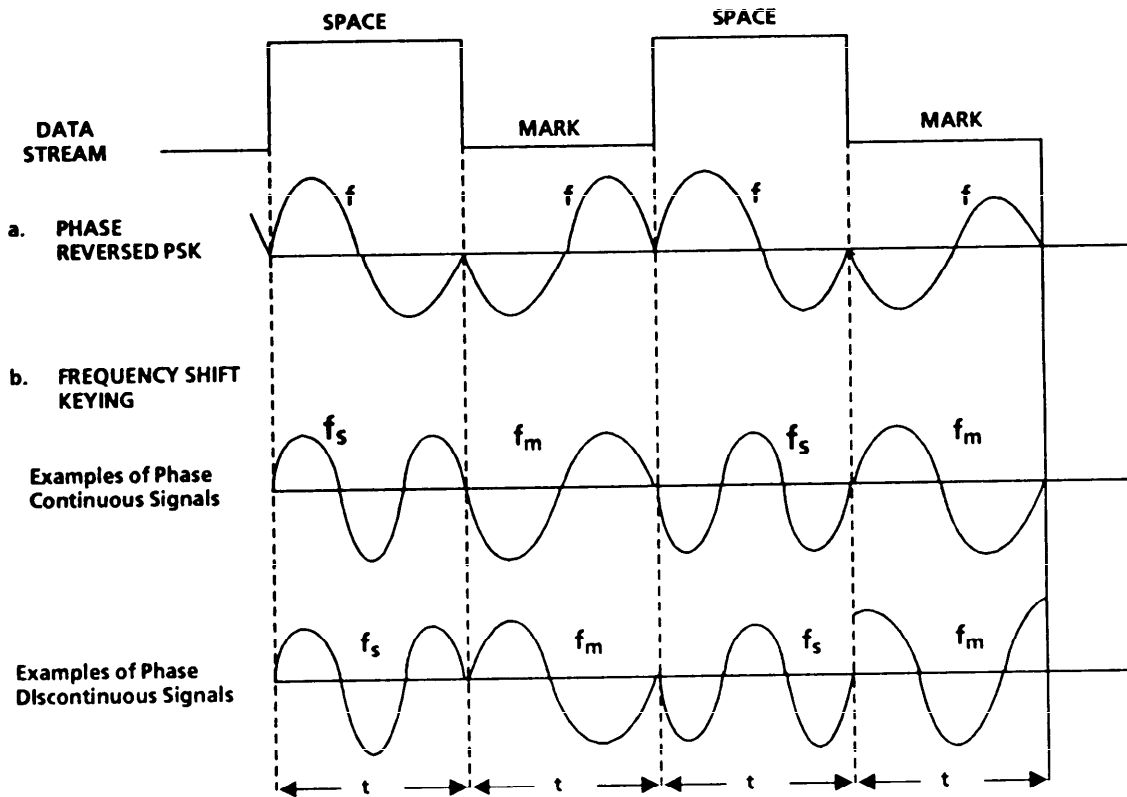

f = Carrier Frequency
 f_m = Mark Frequency
 f_s = Space Frequency

FIGURE A-1. PSK and FSK transitions

20.4.3 Modulation with a modulation index of 0.5 As indicated in FIGURE A-2, conventional FSK with a modulation index of 0.5 will result in a serious phase discontinuity every other transition period, which can result in transmitter outages (kickdowns). Modulation techniques have been developed which provide an FSK type waveform utilizing a modulation index of 0.5 with acceptable phase continuity and with half the RF bandwidth of conventional FSK for the same modulation rate. Two such techniques are Compatible Shift Keying (CSK) and Minimum Shift Keying (MSK).

20.4.3.1 Compatible shift keying (CSK). CSK is characterized by a modulation technique having a modulation index of 0.5. FIGURE A-3 illustrates how this is accomplished using SPACE and MARK frequencies and 180-degree phase shifted frequencies thereof. It must be understood that this example (and the one for MSK in 20.4.3.2) illustrates only one of several techniques to generate the same waveform. In the illustrated case of FIGURE A-3 both the SPACE (f_s) and MARK (f_m) frequencies and those frequencies 180 degrees out of phase, that is, $f_s \angle -180^\circ$ and $f_m \angle -180^\circ$ are available and the proper frequencies are selected at the instant of transition so that the serious phase discontinuity is avoided.

20.4.3.2 Minimum shift keying (MSK). MSK is a modulation technique which results in an FSK type of waveform with a modulation index of 0.5 identical to that of CSK. Hence, CSK and MSK equipment can be compatible in some modes of operation.

20.4.3.2.1. MSK modulation MSK modulation is achieved by phase modulation and amplitude shaping of two subcarrier frequencies that are then added together linearly to produce a frequency shifted carrier wave of constant amplitude and continuous phase. FIGURE A-4 illustrates one implementation of the MSK modulation process. Two channels of synchronous data, X channel and Y channel, are applied to two amplitude modulators for multiplication by two time quadrature sine wave weighting functions; the X channel data is multiplied by a $\cos(\omega_f t)$ weighting function (where ω_f is the weighting function radian frequency) and the Y channel data is multiplied by a $\sin(\omega_f t)$ weighting function. The two amplitude weighted signals phase modulate X subchannel and Y subchannel subcarrier time quadrature signals of $\cos(\omega_o t)$ and $\sin(\omega_o t)$, respectively (where ω_o is the subcarrier radian frequency). The two phase modulated output frequencies are then combined (or linearly added) to produce a constant-amplitude phase-continuous MSK modulator output waveform with instantaneous frequency shifts occurring at times of subchannel bit transitions.

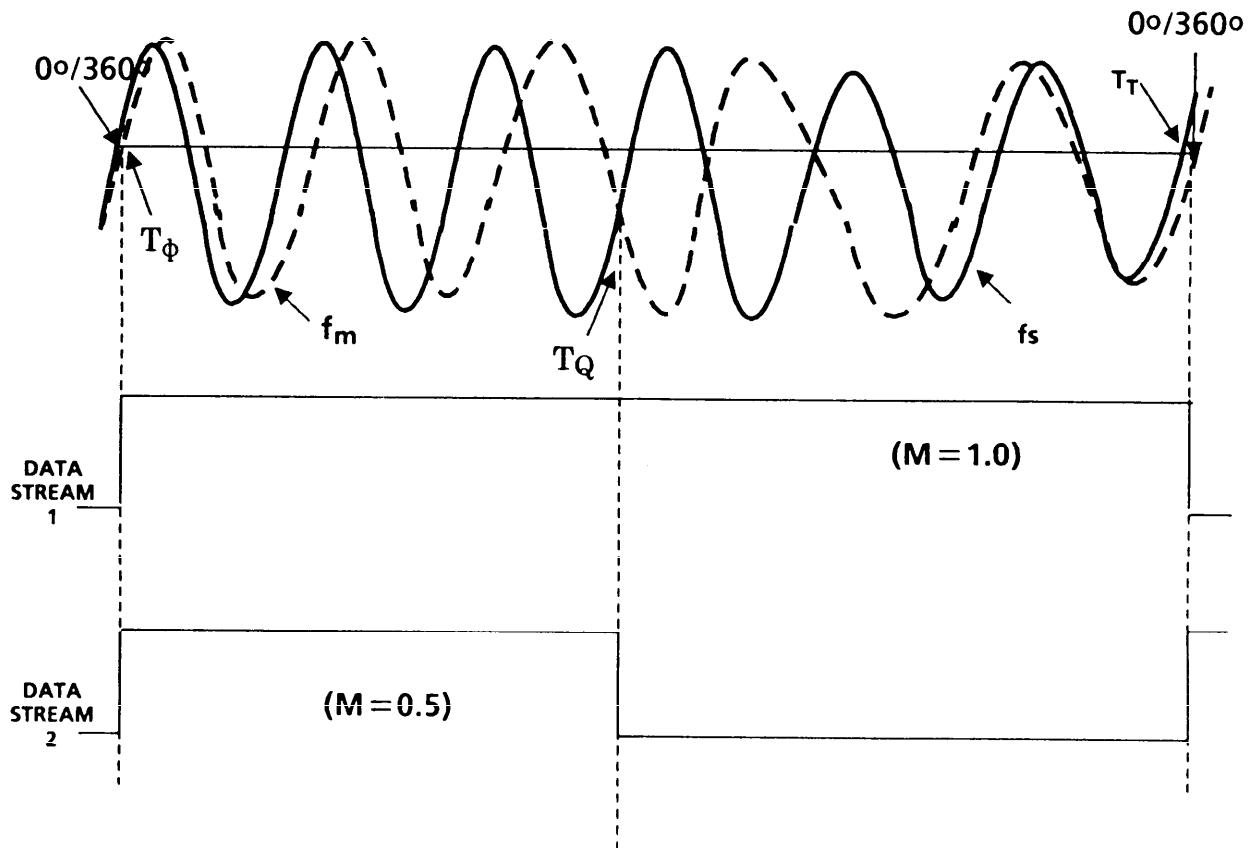

As shown above, DATA STREAM 1 properly matches the difference frequency ($f_s - f_m$) and thus is phase continuous at the bit transition at T_T ($M = 1.0$).

DATA STREAM 2 does not fully match the difference frequency ($f_s - f_m$) and is not phase continuous at the bit transition at T_Q ($M = 0.5$).

Careful selection of the relationship of the difference frequency ($f_s - f_m$) and the bit rate (baud) of an FSK system will provide the desired phase continuity of an $M = 1.0$ system.

FIGURE A-2. Phase continuity and discontinuity in FSK

MIL-STD-188-140A
APPENDIX A

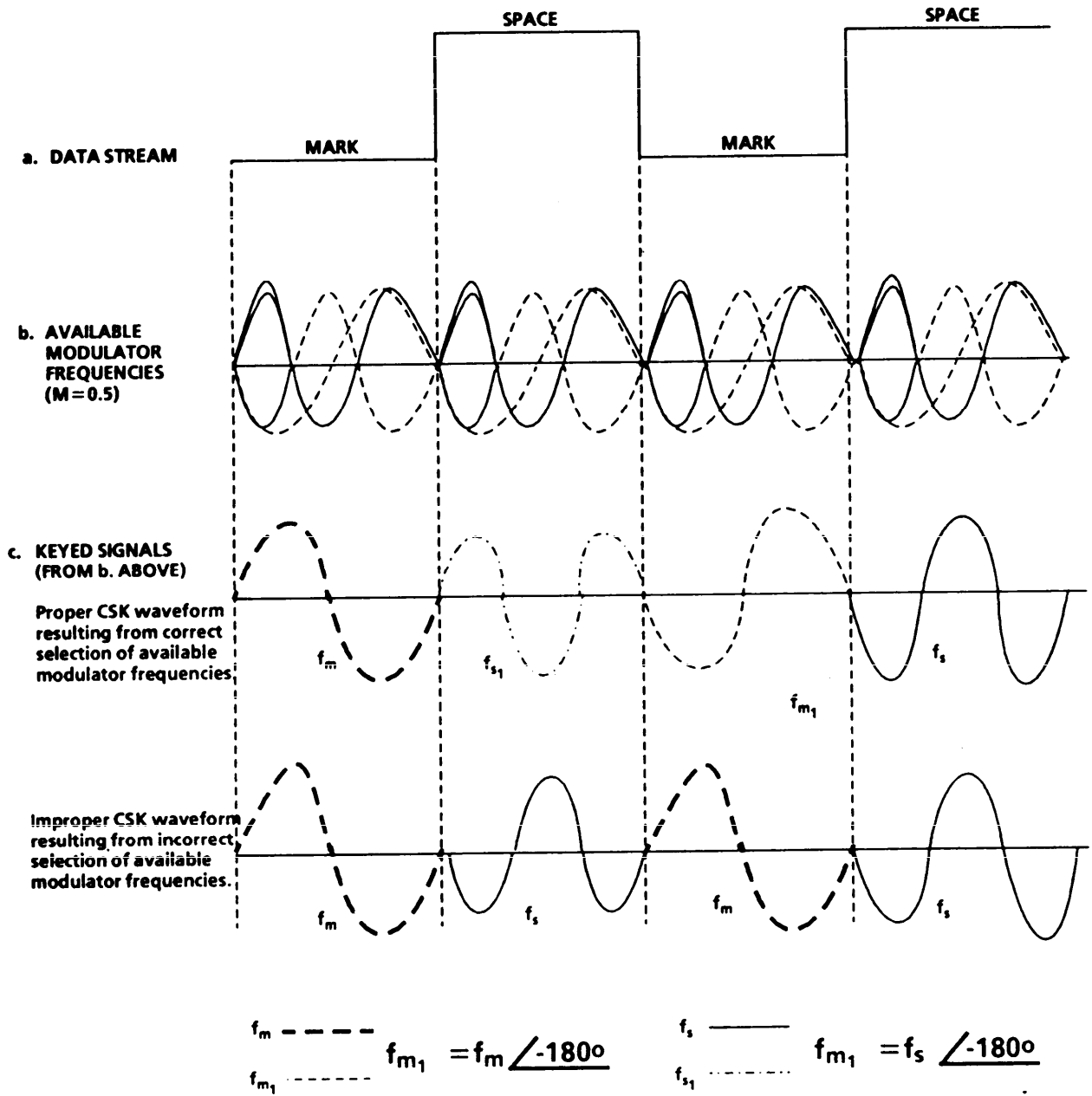

FIGURE A-3. CSK transitions

20.4.3.2.2 MSK derivation. If D_x and D_y represent the digital data inputs from the X and Y channels, respectively, (the digital data from each channel will be a series of mark and space bits appearing in various sequence combinations) to the MSK modulator, the output from the modulator will assume one of four possible waveforms to the D_x and D_y input data. The inputs into the MSK summer at the MSK modulator output depicted in FIGURE A-4 are:

$$D_x \cos(\omega_f t) \cos(\omega_o t) \quad \text{and}$$

$$D_y \sin(\omega_f t) \sin(\omega_o t)$$

since

$$\cos(a) \cos(b) = \frac{1}{2} \left[\cos(a + b) + \cos(a - b) \right] \quad \text{and}$$

$$\sin(a) \sin(b) = \frac{1}{2} \left[\cos(a - b) - \cos(a + b) \right]$$

and if $a = \omega_o t, b = \omega_f t$

then $D_x \cos(\omega_f t) \cos(\omega_o t) = \frac{D_x}{2} \left[\cos(\omega_o + \omega_f)t + \cos(\omega_o - \omega_f)t \right]$ and

$$D_y \sin(\omega_f t) \cos(\omega_o t) = \frac{D_y}{2} \left[\cos(\omega_o - \omega_f)t - \cos(\omega_o + \omega_f)t \right]$$

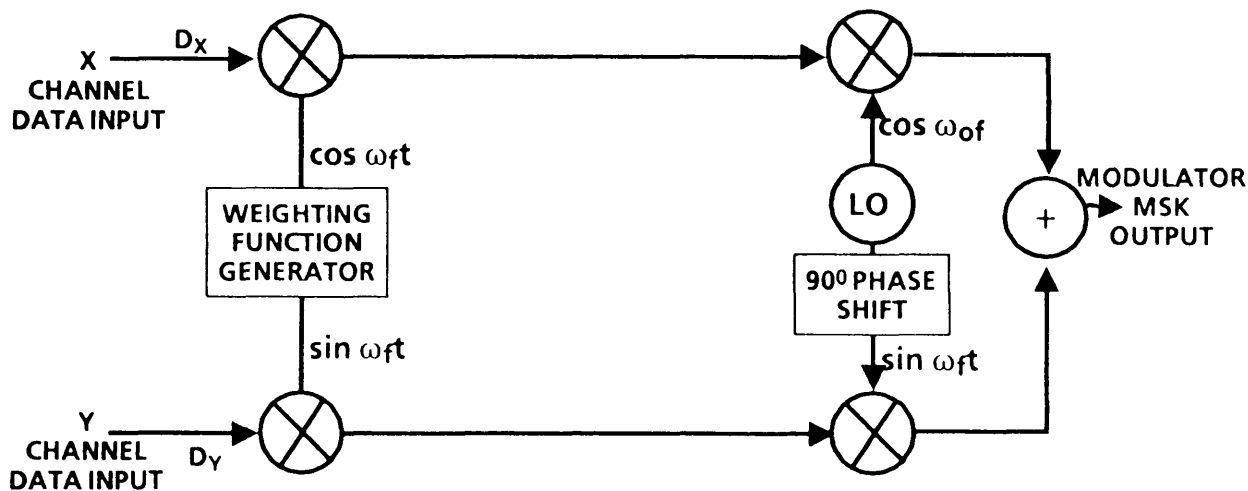

FIGURE A-4. MSK modulator diagram

The output from the MSK modulator is therefore:

$$\text{output} = \underbrace{\frac{D_x}{2} [\cos(\omega_0 + \omega_f)t + \cos(\omega_0 - \omega_f)t]}_{\text{"X" SUBCHANNEL DATA}} + \underbrace{\frac{D_y}{2} [\cos(\omega_0 - \omega_f)t - \cos(\omega_0 + \omega_f)t]}_{\text{"Y" SUBCHANNEL DATA}}$$

TABLE A-I. Allowable MSK output waveform

Data Input		MSK Output Waveform
D _x	D _y	
+ 1 (mark)	+ 1 (mark)	+ cos (ω ₀ -ω _f)t
-1 (space)	-1 (space)	-cos (ω ₀ -ω _f)t
-1 (space)	+ 1 (mark)	-cos (ω ₀ + ω _f)t
+ 1 (mark)	-1 (space)	+ cos (ω ₀ + ω _f)t

If +1 represents a digital data mark input and -1 represents a digital data space input, the MSK modulator output waveform reduces to the four allowable waveforms indicated in TABLE A-I and shown in FIGURE A-5. Since the MSK output is determined by the X and Y channel digital data input to the X and Y subchannels, the MSK modulator output waveform will either change or remain the same every data bit period (T). Reference to TABLE A-I indicates that certain bit transitions (for example, the transitions from mark/mark to space/space and vice versa, the transitions from space/mark to mark/space and vice versa) cannot be allowed to occur if phase discontinuities in the MSK output waveform are to be prevented.

The allowable transitions will be those in which only one of the subchannels is allowed to change at the end of a data bit period, T . By lengthening the bit period to $2T$ and inputting the X and Y channel data into the subchannels as indicated in FIGURE A-6, only one of the subchannels can change during each time interval, T . In addition, the subchannel that is allowed to change during a time interval T , is determined by whether the transition occurs at an even or odd multiple of T . The allowable transitions at even and at odd multiples of T as derived from FIGURE A-6 are shown in TABLE A-II.

TABLE A-II Allowable data transitions

(a) For even multiples of T , where $t = 2T, 4T, 6T \dots 2nT$, only subchannel X can change as follows:

SUBCHANNELS		Subchannel X changes to \longrightarrow (Subchannel Y does not change)	SUBCHANNELS	
X	Y		X	Y
M	M		S	M
S	S		M	S
M	S		S	S
S	M		M	M

(b) For odd multiples of T , where $t = T, 3T, 5T \dots (2n + 1) T$, only subchannel Y can change as follows:

SUBCHANNELS		Subchannel Y changes to \longrightarrow (Subchannel X does not change)	SUBCHANNELS	
X	Y		X	Y
M	M		M	S
S	S		S	M
M	S		M	M
S	M		S	S

M = Mark
 S = Space
 $n = 0, 1, 2, 3, \dots$

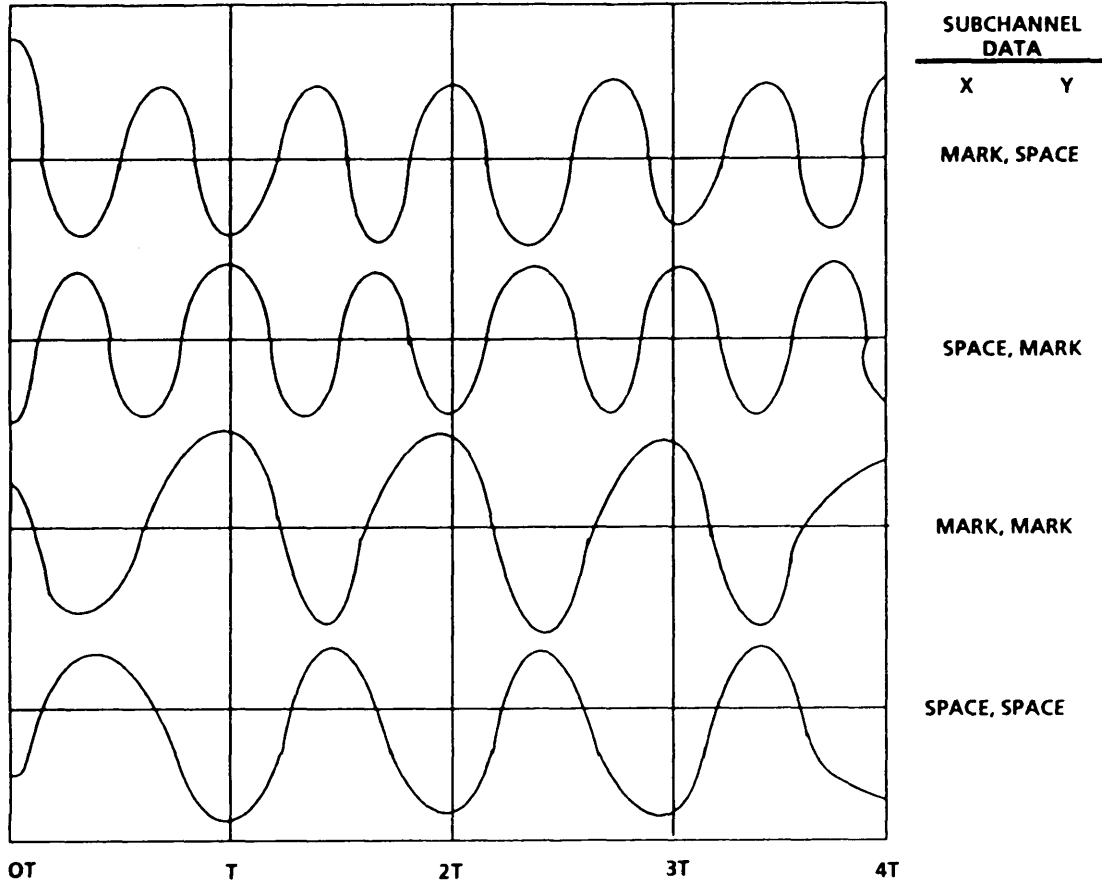

FIGURE A-5. The four allowable waveforms for MSK modulation

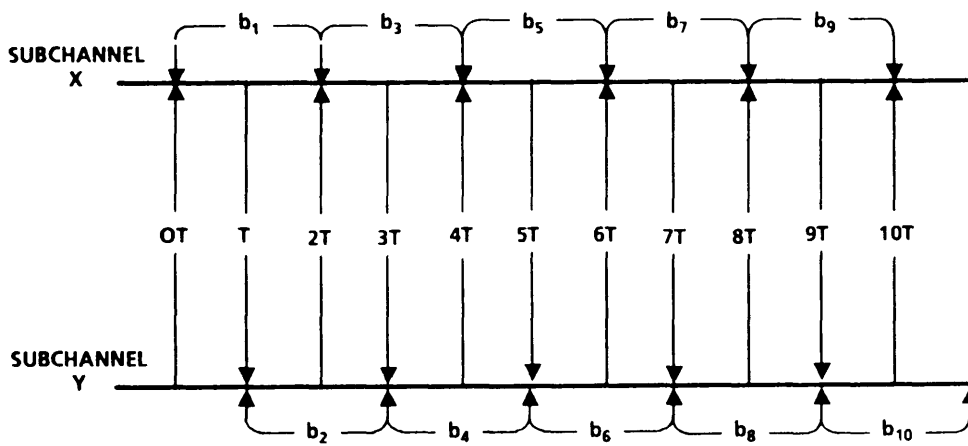

FIGURE A-6. Input data timing

By reference to TABLE A-II it is evident that by lengthening the bit period to $2T$ for each subchannel and by delaying the lengthened bits of one subchannel with respect to the lengthened bits of the other subchannel by T , mark/mark to space/space transitions (and vice versa) and space/mark to mark/space transitions (and vice versa) will not be present. However, in order to ensure phase continuity in the allowable data transitions indicated in TABLE A-II the upper radian frequency ($\omega_o + \omega_f$) and the lower radian frequency ($\omega_o - \omega_f$) must be uniquely related. For a modulation index of 0.5 and a given subcarrier radian frequency (ω_o , the subcarrier or center frequency is not transmitted), the upper and lower radian frequencies and the weighting function radian frequency (ω_f) are determined by the bit rates, B , of the X and Y channels as follows:

$$\frac{(\omega_o + \omega_f) - (\omega_o - \omega_f)}{2\pi} = 0.5B = \frac{0.5}{T} = 2f_f$$

from which

$$T = \frac{1}{4f_f} = \frac{T_f}{4} \text{ (where } f_f \text{ is defined as frequency of weighting function)}$$

or

$$T_f = 4T \text{ (where } T_f \text{ is defined as period of weighting function)}$$

The period of the weighting function is therefore four times the data channel bit period.

20.4.3.2.3 MSK demodulation. To demodulate the MSK waveform the frequency shifts between the upper and lower radian frequencies (between $\omega_o + \omega_f$ and $\omega_o - \omega_f$) could be detected in order to obtain the digital data from the transmitted MSK waveform.

A more efficient method, however, is the detection of the phase shifts in the modulated signal over a bit period, T , relative to the subcarrier radian frequency (ω_0). If $(\omega_0 + \omega_f)$ is the upper transmitted radian frequency and $(\omega_0 - \omega_f)$ is the lower transmitted radian frequency, the phase shifts in the modulated signal over a bit period, T , can be determined from an application of:

$$\omega = 2\pi f = \frac{\Delta\phi}{\Delta T}$$

or

$$\Delta\phi = \omega \Delta T$$

from which

$$\left[\Delta\phi_U = (\omega_0 + \omega_f) - (\omega_0) \right] \Delta T$$

$$\left[\Delta\phi_L = (\omega_0 - \omega_f) - (\omega_0) \right] \Delta T$$

$\Delta\phi_U$ = Upper Radian Frequency Phase Shift

$\Delta\phi_L$ = Lower Radian Frequency Phase Shift

$$\Delta\phi_U = 2\pi f_f \Delta T$$

$$\Delta\phi_L = -2\pi f_f \Delta T$$

now

$$f_f = \frac{1}{4T}$$

and if the phase shift is determined for a bit period, T , then

$$\Delta T = T$$

and

$$\Delta\phi_U = \frac{\pi}{2} = 90^\circ$$

$$\Delta\phi_L = -\frac{\pi}{2} = -90^\circ$$

The MSK demodulator therefore need detect only positive and negative phase shifts of 90 degrees in order to recover the digital data from the transmitted MSK signal.