

METRIC

MIL-PRF-24596A(SH)
w/INT. AMENDMENT 1
9 August 2006

USED IN LIEU OF
MIL-PRF-24596A(SH)
14 July 1999

PERFORMANCE SPECIFICATION

COATING COMPOUNDS, NONFLAMING, FIRE-PROTECTIVE (METRIC)

This specification is approved for use by the Naval Sea Systems Command and is available for use by all Departments and Agencies of the Department of Defense.

1. SCOPE

1.1 Scope. This specification covers nonflaming and fire-protective coatings which are suitable for use where volatile organic content air pollution regulations apply for solvents in paints and for application over certain selected surfaces.

1.2 Classification. Coating compounds covered by this specification are of the following types, classes, grades and applications, as specified (see 6.2):

1.2.1 Types. The types of coating compounds are as follows:

Type I- Non-intumescent, nonflaming.

Type II - Intumescent, fire-protective.

1.2.2 Classes. The classes of coating compounds are as follows:

Class 1 - Surface ship, general usage.

Class 2 - Submarine, general usage.

Class 3 - Submarine (underway use only) (see 6.1.2)

Comments, suggestions, or questions on this document should be addressed to Commander, Naval Sea Systems Command, ATTN: SEA 05Q, 1333 Isaac Hull Avenue, SE, Stop 5160, Washington Navy Yard DC 20376-5160 or emailed to CommandStandards@navy.mil, with the subject line "Document Comment". Since contact information can change, you may want to verify the currency of this address information using the ASSIST Online database at <http://assist.daps.dla.mil>.

MIL-PRF-24596A(SH)
w/INT. AMENDMENT 1

1.2.3 Grades. The grades of coating compounds are as follows:

- Grade A - Water base, air dry at temperatures less than 38°C; maximum volatile organic content (VOC) not to exceed 120 g/L (grams per liter) of paint.
- Grade B - Water base, requiring baking at temperatures above 87°C; VOC not to exceed 275 g/L of paint.
- Grade C - Solvent base, air dry at temperatures less than 38°C; VOC not to exceed 340 solvent g/L of paint.
- Grade D - Solvent base, air dry at temperatures less than 38°C; VOC not to exceed 420g/L of paint.
- Grade E - Solvent base, requiring baking at temperatures above 87°C; VOC not to exceed 275 g/L of paint.

1.2.4 Applications. The applications of coating compounds are as follows:

- Application A - Steel.
- Application B - Aluminum.
- Application C - Fiber reinforced plastics (FRP).
- Application D - Wood.
- Application E - Elastomeric foam insulation.

2. APPLICABLE DOCUMENTS

2.1 General. The documents listed in this section are specified in sections 3, 4, or 5 of this specification. This section does not include documents cited in other sections of this specification or recommended for additional information or as examples. While every effort has been made to ensure the completeness of this list, document users are cautioned that they must meet all specified requirements of documents cited in sections 3, 4, or 5 of this specification, whether or not they are listed.

2.2 Government documents.

2.2.1 Specifications, standards, and handbooks. The following specifications, standards, and handbooks form a part of this document to the extent specified herein. Unless otherwise specified, the issues of these documents are those cited in the solicitation or contract.

SPECIFICATIONS

FEDERAL

TT-P-64 - Primer, Paint, Zinc-Molybdate, Alkyd Type.

MIL-PRF-24596A(SH)
w/INT. AMENDMENT 1

DEPARTMENT OF DEFENSE

MIL-P-15280 - Plastic Material, Unicellular (Sheets and Tubes).

MIL-DTL-24607 - Enamel, Interior, Non-flaming (Dry), Chlorinated Alkyd Resin,
Semi-gloss (Metric).

MIL-P-24441/20 - Paint, Epoxy Polyamide, Green Primer, Formula 150, Type III.

MIL-P-24441/29 - Paint, Epoxy Polyamide, Green Primer, Formula 150, Type IV.

STANDARDS

FEDERAL

FED-STD-141 - Paint, Varnish, Lacquer and Related Materials: Methods of
Inspection, Sampling and Testing of.

FED-STD-595 - Colors Used in Government Procurement.

(Unless otherwise indicated, copies of the above specifications standards and handbooks are available from the Standardization Document Order Desk, 700 Robbins Avenue, Building 4D, Philadelphia, PA 19111-5094.)

2.2.2 Other Government documents, drawings, and publications. The following other Government documents, drawings, and publications form a part of this document to the extent specified herein. Unless otherwise specified, the issues are those cited in the solicitation.

UNITED STATES ENVIRONMENTAL PROTECTION AGENCY (USEPA)

49 CFR 171-178 - Hazardous Materials Regulations

40 CFR 355 Appendixes A and B - The List of Extremely Hazardous Substances and
Their Threshold Planning Quantities.

40 CFR 372.65 - Specific Toxic Chemical Listings.

40 CFR ch.1, part 60, appendix A, method 24 - Determination of Volatile Matter
Content, Water Content, Density, Volume Solids and Weight Solids of Surface
Coatings.

40 CFR Part 82 – Protection of Stratospheric Ozone.

40 CFR Part 261, Appendix II, Toxicity Characteristic Leaching Procedure (TCLP).

DEPARTMENT OF LABOR (DoL)

OCCUPATIONAL SAFETY AND HEALTH ADMINISTRATION (OSHA)

MIL-PRF-24596A(SH)
w/INT. AMENDMENT 1

29 CFR 1910.1001J, Validated Analytical Method ID-191, "Polarization Light Microscopy of Asbestos"

29 CFR 1910.1000 - Subpart Z, Toxic and Hazardous Substances

29 CFR 1990 - Identification, Classification, and Regulation of Potential Occupational Carcinogens

(The Code of Federal Regulations (CFR) is for sale on a subscription basis by the Superintendent of Documents, U.S. Government Printing Office, Washington, DC 20402. Copies of certain regulations and publications may be obtained from the Federal agency responsible for issuance thereof.)

2.3 Non-Government publications. The following documents form a part of this document to the extent specified herein. Unless otherwise specified, the issues of these documents are those cited in the solicitation or contract.

AMERICAN SOCIETY FOR TESTING AND MATERIALS (ASTM)

- B 117 - Standard Method of Salt Spray (Fog Testing).
(DoD adopted)
- D 93 - Flash Point by Pensky-Martens Closed Tester.
(DoD adopted)
- D 522 - Standard Test Method for Mandrel Bend Test of Attached Organic Coatings.
(DoD adopted)
- D 523 - Standard Test Method for Specular Gloss.
(DoD adopted)
- D 562 - Standard Test Method for Consistency of Paints Using the Stormer Viscometer.
(DoD adopted)
- D 610 - Standard Method of Evaluating Degree of Rusting on Painted Steel Surfaces.
(DoD adopted)
- D 714 - Standard Method of Evaluating Blistering of Paints. (DoD adopted)
- D 1308 - Standard Test Method for Effect of Household Chemicals on Clear and Pigmented Organic Finishes. (DoD adopted)
- D 1475 - Standard Test Method for Density of Paint Varnish, Lacquer, and Related Products.
(DoD adopted)
- D 1640 - Standard Test Methods for Drying, Curing, or Film Formation at Room Temperature.
(DoD adopted)
- D 1729 - Standard Practice for Visual Evaluation of Color Differences of Opaque Materials.
(DoD adopted)
- D 2243 - Standard Test Method for Freeze-Thaw Resistance of Waterborne Coatings.
(DoD adopted)
- D 2247 - Standard Practice for Testing Water Resistance of Coatings in 100% Relative Humidity.
(DoD adopted)
- D 2369 - Standard Test Method of Volatile Content of Coatings. (DoD adopted)
- D 2621 - Standard Test Method for Infrared Identification of Vehicle Solids From Solvent-Reducible Paints.
- D 2698 - Standard Method for Determination of the Pigment Content of Solvent Reducible Paints by High-Speed Centrifuging. (DoD adopted)
- D 2805 - Standard Test Method for Hiding Power of Paints by Reflectometry. (DoD adopted)
- D 3273 - Standard Test Method for Resistance to Growth of Mold on the Surface of Interior Coatings in and Environmental Chamber. (DoD adopted)

MIL-PRF-24596A(SH)
w/INT. AMENDMENT 1

- D 3274 - Standard Test Method for Evaluating Degree of Surface Disfigurement of Paint films by Microbial (Fungal or Algal) Growth or Soil and Dirt Accumulation. (DoD adopted)
- D 3278 - Standard Test Methods for Flash Point of Liquids by Small Scale Closed-Cup Apparatus. (DoD adopted)
- D 3723 - Standard Test Method for Pigment Content of Water-Emulsion Paints by Low-Temperature Ashing. (DoD adopted)
- E 162 - Standard Test Method for Surface Flammability of Materials Using a Radiant Heat Energy Source.
(DoD adopted)
- E 260 - Practice for Packed Column Gas Chromatography.
- E 313 - Standard Test Method for Indexes of Whiteness and Yellowness of Near-White, Opaque Materials.
- E 662 - Standard Test Method for Specific Optical Density of Smoke Generated by Solid Materials.(DoD adopted)
- E 1252 - Standard Practice for General Techniques for Qualitative Infrared Analysis.
- F 718 - Standards for Shipbuilders and Marine Paints and Coatings.
- G 53 - Standard Practice for Operating Light- and Water-Exposure Apparatus (Fluorescent UV Condensation Type) for Exposure of Non-metallic Materials. (DoD adopted)

(Application for copies should be addressed to the ASTM, 100 Bar Harbor Drive, West Conshohocken, PA 19428-2959.)

INTERNATIONAL AGENCY FOR RESEARCH ON CANCER (IARC)

International Agency for Research on Cancer (IARC)
Monograph

(Application for copies should be addressed to the WHO Publication Center, 49 Sheridan Avenue, Albany, NY 12210.)

NATIONAL TOXICOLOGY PROGRAM (NTP)

Latest Annual Report on Carcinogens, Summary, National Toxicology Program

(Application for copies should be addressed to the U.S. Department of Health and Human Services, National Institute of Environmental Health Sciences, Public Information Office, P.O. Box 12233, MD B2-04, Research Triangle Park, NC 27709.)

STEEL STRUCTURES PAINTING COUNCIL (SSPC)

Surface Preparation Specifications

(Requests for copies should be addressed to the Steel Structures Painting Council, 4000 Fifth Avenue, Pittsburgh, PA 15213.)

(Non-Government standards and other publications are normally available from the organizations that prepare or distribute the documents. These documents also may be available in or through libraries or other informational services.)

2.4 Order of precedence. In the event of a conflict between the text of this document and the references cited herein (except for related associated specifications or specification sheets), the text of this document takes precedence. Nothing in this document, however, supersedes applicable laws and regulations unless a specific exemption has been obtained.

MIL-PRF-24596A(SH)
 w/INT. AMENDMENT 1

3. REQUIREMENTS

3.1 Qualification. Coating compounds furnished under this specification shall be products that are authorized by the qualifying activity for listing on the applicable qualified products list before contract award (see 4.2 and 6.3).

3.1.1 Qualification of commercial products specified as Navy Formula No. 25A. Coating compounds certified to meet the requirements of Navy Formula 25A by the manufacturer shall be accepted as meeting the requirements of type I, class 1, grades A and B, all applications and FED-STD-595 colors 24585 (Pastel Green), 26307 (Bulkhead Gray) and 27880 (Soft white) and shall be qualified without testing to type I, class 1, grades A and B, all applications and FED-STD-595 colors 24585 (Pastel Green), 26307 (Bulkhead Gray) and 27880 (Soft white) (see 4.2.2, 4.2.3 and 6.3.3).

3.1.2 Description of coatings. At the time of qualification submittal, manufacturer shall identify all coatings and coating components constituting the coating being qualified by (a) type, class, grade, application and color for which qualification is sought and (b) unique product nomenclature. At a minimum, this unique product nomenclature shall consist of coating name, component identifier (if appropriate), alpha, numeric or alpha-numeric identifier and color. Nomenclature shall be as specific as necessary to uniquely identify product.

2.2 Composition. Coatings shall be furnished in accordance with the requirements of the type, class, grades, and application specified (see 6.2). The composition of the coating furnished to this specification shall be the responsibility of the manufacturer, except as otherwise limited by this specification or the following 29 CFR 1910.1000, 29 CFR 1990, 49 CFR 171-178, 40 CFR 355 Appendixes A and B, 40 CFR 372.65, 40 CFR Part 82, and International Agency for Research on Cancer (IARC) Monographs (see 3.8).

3.2.1 Mix ratios. Where coatings are composed of components to be mixed at the time of application, the minimum proportions for any component shall be at least 5 percent (%) by volume of the total.

3.3 Color

3.3.1 Color of coatings. Coatings shall be qualified in FED-STD-595 color numbers 27880 and 26307 (see 4.3 for extension of qualification to other colors). Colors not listed in table I shall be qualified individually.

3.3.2 FED-STD-595 Color. When tested in accordance with table I, the coating shall match color chip number 27880 and 26307 of FED-STD-595.

3.3.3 Colors shall be supplied as ready mixed products.

TABLE I. Colors.

Color Name	FED-STD-595 Color chip Number
Soft white	27880
Pastel green	24585
Bulkhead gray	26307
Sun glow	23697
Green gray	26496
Yellow gray	26400
Pearl gray	26493
Pastel blue	25526
Beach sand	22563
Rosewood	22519
Clipper blue	24516

MIL-PRF-24596A(SH)
 w/INT. AMENDMENT 1

3.4 Identification characteristics. Coatings shall be identified by product name, color and a unique alpha, numeric or alpha-numeric identifiers. Values for coating identification characteristics and the mixing, application instructions, and test methodology used to determine those characteristics indicated by an “X” in table II, shall be provided by manufacturers seeking QPL listing. The values shall be established for each coating system prior to qualification testing. The purpose of these values is to serve as a basis for determining that the material being offered is essentially the same as that which was approved under qualification testing. Subject to acceptance by the Naval Sea Systems Command, alternative identification characteristics (for example, infrared spectrographic examination, and chemical analysis) may be substituted for the characteristics in table II, provided appropriate test methodology and test data are submitted by the contractor.

TABLE II. Required Identification characteristics.

Characteristic	Single component Materials	Multiple component coatings		
		Coating component ¹ (Part A and B)	Coating ² (Parts A and B, mixed)	Coating system ³ (multiple coats in accordance with contractor’s instructions)
Chemical nature of resin(s)	X	X	---	---
Percent of principal constituents (5 percent (%) by weight (%WT) or more of total)	X	X	---	---
Pigment, %WT	X	X	---	---
Nonvolatile vehicle, %WT	X	X	---	---
Total solids, %WT	X	X	---	---
Color (as descriptive name and FED-STD-595 Number)	X	X	X	X
Volatile, %WT	X	X	---	---
Mass per unit volume in g/L (lb/gal)	X	X	X	---
Viscosity in Kreh units (KU) or Poise	X	X	X	---
Flash point as Setaflash or Pensky-Martin Closed Cup, degrees °C	X	---	X	X
Pot life in hours (hr)	---	---	X	---
Drying time to touch and dry hard time or curing time in hr.	X	---	X	X
Specular gloss (%)	X	---	X	---
Hiding power (contrast ratio)	X	---	---	X
Volatile organic content, g/L	X	X	X	X
Mixing instructions	X	X	X	---
Application instructions	X	---	X	---

NOTES:

1. Coating components are individually packaged components such as base component (Part A), converter component or hardener (Part B), or liquid portion, powder portion and curing solution. Indicate only applicable characteristics.
2. Coatings are the coating components as mixed for application.
3. Coating system is total system (number and type of coats approximately dry film thickness as tested for qualification approval).

MIL-PRF-24596A(SH)
 w/INT. AMENDMENT 1

3.5 Quantitative requirements. Unless otherwise stated, the following tests apply to all types, all classes, all grades and all applications.

3.5.1 Volatile Organic Content (VOC) Solvent. When tested in accordance with 4.6.4, the VOC of appropriate grades shall not exceed the value listed:

Grade	Maximum VOC
A	120 g/L
B	275 solvent g/L
C	340 g/L
D	420 g/L
E	275 g/L

3.5.2 Class 3 volatiles. When tested in accordance with NAVSEA classified methodology (see 4.6.4.1), the volatile portion of the formulation for class 3 coatings shall comply with the classified requirements for NAVSEA submarine atmosphere control (See 6.3.2).

3.5.3 Hazardous air pollutant (HAP) content. When tested in accordance with 4.6.5, the content of HAPs solvents in the liquid coating shall not exceed the weight percent (%WT) values listed in table III. Within these limitations and the requirement that the finished coating meet all requirements of this specification, solvent selection is the responsibility of the manufacturer.

TABLE III. Hazardous air pollutant solvent content limits.

Hazardous Solvent in each individual total paint	Maximum, %WT
Benzene	0.05
Chlorinated solvent(s), total	0.05
Solvents containing Fluorine as defined by 40 CFR Part 82	0.01
Ethyl benzene	0.05
Methyl, Ethyl and Butyl mono-ethers of Ethylene glycol or the acetates thereof, total (Also known as Methyl, Ethyl and Butyl Cellosolves and Methyl, Ethyl and Butyl Cellosolve acetates)	0.05
Methyl ethyl ketone (MEK)	0.05
Methyl isobutyl ketone (MIBK)	0.05
Toluene	0.05
Xylene (all forms), total	0.1

3.5.4 Hazardous Pigments and additives. When tested in accordance with 4.6.6, the content of each soluble metal and total content of each metal of the coating shall be less than the values listed in table IV. In addition, asbestos and asbestos from pigment shall not exceed 5 mg/L.

MIL-PRF-24596A(SH)
 w/INT. AMENDMENT 1

TABLE IV. Metals content of coatings.

Metal and/or its compound in each coating dry film	Soluble metal, Maximum, mg/L	Total metals content, Maximum, %WT
Antimony	15	0.015
Arsenic	5	0.005
Barium (excluding barite)	100	0.10
Beryllium	0.75	0.0002
Cadmium	1	0.0005
Chromium (VI) compounds	1	0.001
Chromium [including chromium (III)]	560	0.56
Cobalt	50	0.005
Copper	25	0.01
Fluoride salts	180	0.18
Lead	5	0.005
Mercury	0.2	0.0002
Molybdenum	350	0.35
Nickel	20	0.02
Selenium	1	0.002
Silver	5	0.001
Tantalum	100	0.100
Thallium	7	0.007
Tungsten	100	0.100
Vanadium	24	0.01
Zinc	250	0.25

MIL-PRF-24596A(SH)
w/INT. AMENDMENT 1

3.5.5 Flash point. When tested in accordance with table V, the flash point of the coating shall not be less than 38°C.

3.5.6 Gloss. When tested in accordance with 4.6.1, specular gloss shall be not less than 45percent and shall not exceed 60 percent.

3.5.7 Yellowness. When tested in accordance with 4.6.7, the yellowness index of panels in light or dark storage shall not increase more than 3 units.

3.6 Qualitative requirements. Unless otherwise stated, the following tests apply to all types, all classes, all grades and all applications.

3.6.1 Condition in container. When tested in accordance with 4.4, the coating or components of a coating system shall be free from grit, seeds, skins, abnormal thickening, or livering in a freshly opened container, and shall show no more pigment settling or caking than can be easily and completely reincorporated to a smooth, uniform state. Water based paints shall also be free of rust staining, emulsion breakdown, spoilage or rancidity. Container shall be free of corrosion.

3.6.2 Mixing properties. When tested in accordance with 4.6.8, the coating shall be free from grit, seeds, skins, or lumps, and shall result in a smooth, uniform mixture. After aging, the coating shall show no signs of gelation or separation.

3.6.3 Spraying properties. When tested in accordance with 4.6.9, the coating shall spray satisfactorily in all respects, and shall show no running, sagging, or streaking. The dried film shall show no dusting, mottling, or color separation and shall present a smooth finish.

3.6.4 Brushing properties. When tested in accordance with 4.6.10, the coating shall brush satisfactorily in all respects and shall dry to a smooth, uniform film, free from seeds, runs, or sags.

3.6.5 Flexibility. When tested in accordance with 4.6.11, a film of coating shall show no checking, cracking, or flaking.

3.6.6 Knife test adhesion. When tested in accordance with 4.6.12, the coating film shall be difficult to furrow off with the knife and shall not flake, chip, or powder, show no loss of inter-coat adhesion, nor loss of adhesion to the surface of the substrate. The knife cut shall show beveled edges.

3.6.6.1 Adhesion test. When tested in accordance with 4.4, a film of coating shall adhere tightly to the test panel.

3.6.7 Fluid resistance.

3.6.7.1 Water resistance (does not apply to grades A and B water based coatings). When tested in accordance with 4.6.13, a film of coating shall show no wrinkling or blistering immediately after removal of the wetted sponges. The coating shall be no more than slightly affected when examined 2 hours after removal of the wetted sponges. After 24 hours of air drying, the portion of the panel which was covered by the wetted sponges shall be almost indistinguishable with regard to hardness and adhesion from the portion which was not immersed. A slight discoloration of the portion of the panel covered by the wetted sponges shall be permitted.

MIL-PRF-24596A(SH)
 w/INT. AMENDMENT 1

3.6.7.2 Hydrocarbon fluid resistance (does not apply to grades A and B water base coatings). When tested in accordance with 4.6.14, a film of coating shall show no blistering or wrinkling and no more than a slight whitening or softening upon removal of the fluid wetted sponge. After 2 hours of air drying, the portion of the panel that was covered by fluid wetted sponge shall be almost indistinguishable with regard to hardness, color, and gloss from a panel prepared at the same time, but not immersed.

3.6.7.3 Salt spray resistance (does not apply to application C, D and E coatings). When tested in accordance with 4.6.15, a film of coating examined immediately after removal from the test shall show no more than a trace of corrosion in accordance with ASTM D 610 and no more than five scattered blisters no larger than 1 mm in diameter.

3.6.7.4 Condensation blister resistance. When tested in accordance with 4.6.16, a film of coating shall show a maximum ASTM D 714 blister rating of 8 and be rated few or better. Blister growth shall be limited to a rating of 6 and rated few when evaluated in accordance with ASTM D 714 at 300 and 500 hours. Blisters within 12 mm of all edges shall be disregarded.

3.6.8 Resistance to exudate formation (grades A and B water base coatings only). When tested in accordance with 4.6.17, a film of coating shall exude no fluid (liquid) material from the paint film and paint film shall not be tacky.

3.6.9 Washability. When tested in accordance with 4.6.18, a film of coating shall retain a minimum of 50 percent of its original gloss.

3.6.10 Flash rust resistance (grades A and B application A water base coatings only). When tested in accordance with 4.6.19, there shall be no evidence of flash rust or pinhole corrosion

3.6.11 Resistance to growth of mold. When tested in accordance with table V, after 4 weeks, the test panels shall have a minimum ASTM D 3274 rating of 8.

3.6.12 Freeze-thaw resistance (grades A and B only). When tested for five cycles in accordance with table V, the coating shall not: (a) broken emulsion or (b) agglomerated or coagulated. There shall be no change in: (a) hiding power, (b) gloss, (c) fineness of grind or (d) speckiness. Color shall match the standard color card of the appropriate FED-STD 595 color. Viscosity shall be within 10 percent of the viscosity of the control. Brushability and sprayability shall be the same as the control.

3.6.13 Recoatability. When tested in accordance with 4.6.20, the paint shall not wrinkle, blister or lift. When cut with a knife blade, the overcoat paint shall not loose adhesion or flake away from the test paint film. The surface of the recoat paint shall be smooth.

3.7 Thermal properties. Unless otherwise specified, all paints regardless of application shall be tested to these requirements.

3.7.1 Radiant Panel. When tested in accordance with 4.6.21.2, type I and type II coating systems shall have the following maximum flame spread indices:

Application	Maximum flame spread index
A	5
B	5
C	10
D	10
E	25

MIL-PRF-24596A(SH)
 w/INT. AMENDMENT 1

Type II coatings shall not allow exposure of the substrate to the flame and heat sources for the duration of the test.

3.7.2 Smoke density. When tested in accordance with 4.6.21.3, type I and type II coating systems shall have the following maximum smoke generation values:

Application	Maximum allowed smoke density
A	15
B	15
C	20
D	30
E	40

Type II coatings shall not allow exposure of the substrate to the flame and heat sources for the duration of the test.

3.7.3 Resistance to ignition (application A only). When tested in accordance with 4.6.21.4, types I and II coatings shall not exhibit flaming, sparking, fumes or smoke, or burning drops in excess of that of the control MIL-DTL-24607.

3.7.4 Flashover and hazardous emissions. When tested in accordance with the requirements of 4.6.21.5, test coating shall not flashover in 10 minutes and emissions of the indicated compounds shall not exceed the value listed:

Compound	Maximum ILDH value, parts per million (ppm)
HCN	50
HCL	100
CO ₂	50,000
CO	1500

3.7.5 Heat transfer (type II only). When tested in accordance with the requirements of 4.6.21.6, the temperature recorded at not less than 7 of the 8 thermocouples shall not exceed 232 C for the first 10 minutes of the test.

3.8 Toxicity (all types, all classes, all grades and all applications). The coatings shall not contain the following materials in excess of 0.06% by weight of the dry coating: coal tar or coal tar derivatives, any ACGIH carcinogenic or ACGIH suspected carcinogenic compounds. The coating components and mixed coating shall have no adverse effect on the health of personnel when used for its intended purpose in accordance with the manufacturers instructions. Questions pertinent to this toxicity requirement shall be referred by contracting activity to the qualifying activity. The qualifying activity will act as advisor to the contracting activity. The qualifying activity will arrange for review of questions by the appropriate departmental medical service.

3.9 Batch specific VOC certification. Manufacturer shall prepare label instructions in accordance with 29 CFR 1910. Each container must be affixed with a hazardous chemical warning label in accordance with 29 CFR 1910.1200. To comply with the Environmental Protection Agency (EPA) National Emission Standards for Hazardous Air Pollutants (NESHAP) requirements for shipbuilding and ship repair, the following two statements must appear on each paint can label:

- a. A certification that the paint in the container meets the NESHAP requirements for shipbuilding and ship repair.
- b. A statement of the ratio of volatile content to solids expressed as grams of volatile organic hazardous air pollutants (VOHAPS) per liter of solids.

MIL-PRF-24596A(SH)
 w/INT. AMENDMENT 1

4. VERIFICATION

4.1 Classification of inspections. The inspection requirements specified herein are classified as follows:

- a. Qualification inspection (see 4.2).
- b. Conformance inspection (see 4.4).

4.2 Qualification tests. Qualification inspection tests shall consist of the tests specified in 4.6 and 4.7. Applicants for qualification to class 3 should review special instructions in 6.3.2.

4.2.1 Products shall be qualified to a specific type, class, grade, application and color. The applicable type, class, grade, application and color is supplied by the contractor and becomes a part of the application for qualification testing (see 6.3). Qualification approval for one type, class, grade, or application does not constitute approval of other types, classes, grade, or applications.

4.2.2 Navy formula 25A. Qualification shall be extended to certified coatings manufactured in accordance with the requirements of NAVSEA formula 25A (see 6.3.3) for type I, class 1, grades A and B, applications A, B, C, D and E and colors 24585 (Pastel Green), 26307 (Bulkhead Gray) and 27880 (Soft white) conforming to FED-STD-595 without testing. Other colors based on Navy formula 25A shall be qualified by testing in accordance with 4.2.1.

4.3 Extension of qualification. Qualification shall be only for the specific type, class, grade; application shall not extend to any other type, grade, class or application. Qualification shall not be extended to paints in colors not listed in table I. Qualification shall not be extended to Navy formula 25A in colors other than those listed in 4.2.2. Any paints in colors not listed in table I shall be qualified separately as a commercial product.

4.4 Conformance tests. Conformance inspection shall consist of all tests specified in table V as conformance tests.

TABLE V. Test procedures.

Item	Requirement	Test	FED-STD-141 test method	ASTM test method	Conformance tests
Color	3.3; 3.4	4.6.1	---	D 1729	X
Chemical nature of resin(s)	3.4	4.6.1	---	D 2621 E 1252	---
Principal constituents, %WT	3.4	4.6.1	---	---	---
Pigment, %WT	3.4	4.6.1	---	D 2698 or D 3723	X
Nonvolatile vehicle solids, %WT	3.4	4.6.1	---	D 2698	X
Volatiles, %WT	3.4	4.6.1	---	D 2698	X
Mass per unit volume	3.4	4.6.1	---	D 1475	X
Viscosity	3.4	4.6.1	---	D 562	X
Flash point	3.4; 3.5.5	4.6.1; table V	---	D 93 or D 3278	X
Pot life	3.4	4.6.2	---	---	---
Drying time	3.4	4.6.3	---	D 1640	X
Set to touch	3.4	4.6.3	---	D 1640	X
Dry hard	3.4	4.6.3	---	D 1640	X
Full hardness	3.4	4.6.3.1	---	D 1640	X
Specular gloss	3.4; 3.5.6	4.6.1	---	D 523	---
Hiding power (contrast ratio)	3.4	4.6.1	---	D 2805	---
Adhesion	3.6.6.1	4.6.12	6301.2	---	---

MIL-PRF-24596A(SH)
 w/INT. AMENDMENT 1

TABLE V. Test procedures - Continued.

Volatile content (VOC)	3.4; 3.5.1	4.6.4	---	---	---
Class 3 volatiles	3.5.2	4.6.4.1	---	---	---
Hazardous air pollutant (HAP) content	3.5.3	4.6.5	---	---	---
Hazardous Pigments and Additives	3.5.4	4.6.6	---	---	---
Yellowness	3.5.7	4.6.7	---	E 313	---
Condition in container	3.6.1	4.4	3011.2	---	---
Mixing properties	3.6.2	4.6.8	---	---	---
Spraying properties	3.6.3	4.6.9	4331.1	---	X
Brushing properties	3.6.4	4.6.10	4321.2	---	X
Flexibility	3.6.5	4.6.11	---	D 522	---
Knife test	3.6.6	4.6.12	6304.1	---	---
Resistance to water	3.6.7.1	4.6.13	---	D 1308	---
Resistance to hydrocarbons	3.6.7.2	4.6.14	---	D 1308	---
Resistance to salt spray	3.6.7.3	4.6.15	---	B 117	---
Condensation blister resistance	3.6.7.4	4.6.16	---	D 2247 and D 714	---
Resistance to exudates formation	3.6.8	4.6.17	---	---	---
Washability	3.6.9	4.6.18	6141.1	---	---
Flash rust resistance	3.6.10	4.6.19	---	---	---
Mold resistance	3.6.11	table V	---	D 3273 and D 3274	---
Freeze-thaw resistance	3.6.12	table V	---	D 2243	---
Recoatability	3.6.13	4.6.20	---	---	---
Radiant panel	3.7.1	4.6.21.2	---	E 162	---
Smoke density	3.7.2	4.6.21.3	---	E 662	---
Resistance to ignition	3.7.3	4.6.21.4	---	---	---
Flashover and hazardous Emissions	3.7.4	4.6.21.5	---	---	---
Heat transfer	3.7.5	4.6.21.6	---	---	---
Toxicity	3.8	---	---	---	---
Packaging	Contract	4.7	---	---	---

4.5 Test conditions.

4.5.1 Routine qualification and quality conformance testing. Unless otherwise required, testing shall be conducted at normal (ambient) laboratory conditions of temperature and humidity and all dimensions, temperatures, humidities, volumes and weights are nominal quantities.

4.5.2 Referee testing. Referee testing shall be conducted at a temperature of $23 \pm 1^\circ\text{C}$, and a relative humidity of 50 ± 4 percent.

4.5.3 Test panels. Unless otherwise required, test panels shall be prepared as follows:

4.5.3.1 General.

4.5.3.1.1 Two sets of panels shall be prepared and all tests conducted in duplicate.

MIL-PRF-24596A(SH)
w/INT. AMENDMENT 1

4.5.3.1.2 Metal panels shall have nominal dimensions of 150 mm by 300 mm by 3 mm. Glass reinforced plastic, wood and elastomeric foam insulation in accordance with MIL-P-15280 may be up to 25 mm and shall be adhered with the smooth side up to a metal support panel.

4.5.3.1.3 One set shall be primed with paint conforming to TT-P-645. The other set shall be primed with primer conforming to MIL-P-24441/20 or MIL-P-24441/29. Only the face(s) of the panels subject to test exposure are required to be primed. Application D and E panels shall not be primed unless required for compatibility or adhesion such as water base primer on application E materials.

4.5.3.1.4 Unless other wise specified, primed panels shall be dried (cured) for one week at normal laboratory conditions or overnight at 40°C to 50°C before being topcoated.

4.5.3.1.5 Unless otherwise specified, test coatings shall be applied in accordance with the manufacturer's data sheet or ASTM F 718.

4.5.3.2 Surface preparation.

4.5.3.2.1 Application A (Steel): Panels shall be mild steel. Panels shall be degreased and abrasive blast cleaned with 100 grit aluminum oxide abrasive to SSPC-10 Near White metal with a surface profile not to exceed 0.050 mm to 0.075 mm. Dust shall be removed with clean, dry air or vacuumed away.

4.5.3.2.2 Application B (Aluminum): Panels shall be aluminum. Panels shall be degreased and abrasive blast cleaned with 100 grit aluminum oxide abrasive to a uniform finish with a surface profile not to exceed 0.050 mm to 0.075 mm. Dust shall be removed with clean, dry air or vacuumed away.

4.5.3.2.3 Application C (Fiber reinforced plastics [FRP]): The face (smooth side) of panels shall be degreased and abraded with 100 grit abrasive paper or cloth (sandpaper) to a uniform appearance. Dust shall be removed with clean, dry air or vacuumed away.

4.5.3.2.4 Application D (Wood): Panels shall be solid wood, not plywood. Panels shall be degreased and abraded with 100 grit abrasive paper or cloth (sandpaper) to a uniform appearance. Dust shall be removed with clean, dry air or vacuumed away.

4.5.3.2.5 Application E (MIL-P-15280 Elastomeric foam insulation): Smooth side of the elastomeric foam shall be used for the test surface. Only the smooth side shall be prepared and painted. Panels shall be degreased. Dust shall be removed with clean, dry air or vacuumed away.

MIL-PRF-24596A(SH)
w/INT. AMENDMENT 1

4.6 Test procedures. Tests shall be conducted in accordance with the requirements of table V. For all tests requiring the use of mixed coating, Parts A and B shall be mixed in the proportions specified by, and allowed to stand for the appropriate temperature dependent induction time before using, as recommended by the contractor.

4.6.1 Tests to verify ID characteristic values. Tests shall be conducted in accordance with procedures provided by the manufacturer during qualification filing of ID characteristics. Test results shall be in accordance with the ID characteristics provided by the manufacturer in accordance with the requirements of 3.4.

4.6.2 Pot life. The coatings of the coating system shall be mixed from the components, in accordance with the contractor's instructions, in a container so as to result in approximately 1 Liter of finished material. The time between mixing and the loss of adequate brushing and spraying properties shall be determined. Record for up to a 48 hour period the actual temperature, humidity, and the time of loss of adequate brushing and spraying properties. The pot life shall be in accordance with the requirements of 3.4.

4.6.3 Drying time. Draw down a film of the coating compound with 0.038 mm (0.075 mm gap clearance) film applicator a Leneta chart (or equivalent) and determine set-to-touch and dry hard drying times in accordance with method 4061.2 of FED-STD-141. Test results shall be in accordance with the ID characteristic provided by the manufacturer in accordance with the requirements of 3.4.

4.6.3.1 Full hardness. The film prepared for 4.6.4 shall be considered to have reached full hardness when it is very difficult to remove from the primers with a knife blade. Test results shall be in accordance with the ID characteristic provided by the manufacturer in accordance with the requirements of 3.4.

4.6.4 VOC. VOC shall be determined in accordance with 40 Code of Federal Regulations (CFR) ch.1, part 60, appendix A, method 24. Solvent content shall be in accordance with the requirements of 3.5.1 for the respective grade.

4.6.4.1 Class 3 submarine atmosphere volatiles. This test shall be conducted by NAVSEA in accordance with the classified requirements for testing products intended use in the closed submarine atmosphere. Test results shall be in accordance with the requirements of 3.5.2.

4.6.5 HAP content of coatings. Hazardous solvent content of each coating shall be determined in accordance with ASTM E 260 or Methods 7356 and 7360 of FED-STD-141, as applicable. Solvent fractions shall be identified in accordance with ASTM E 1252. Accuracy shall be of the analysis shall be 0.25%WT absolute and the reproducibility shall be 0.25%WT over a minimum of three runs. Test results shall be reported as %WT of the total enamel. The test results for each solvent shall be in accordance with the requirement in 3.5.3.

4.6.6 Hazardous pigments and additives. Soluble and total metal content, except tantalum and tungsten, shall be determined on a dry paint film of the coatings in accordance with 40 CFR Part 261, Appendix II Toxicity Characteristic Leaching Procedure (TCLP) and the appropriate test listed below. Asbestos shall be analyzed in accordance OSHA validated analytical method ID-191. Test result reported as % by weight of the dry enamel film. Soluble metal content shall be reported as mg/L (parts per million [ppm]). Total metal content shall be reported as %WT of the dry enamel film (1% equaling 10,000 ppm). The test results metal shall be in conformance with the requirements of 3.5.4. Tantalum and tungsten soluble metal content and total metal content shall be analyzed as specified in 4.6.6.1.

MIL-PRF-24596A(SH)
 w/INT. AMENDMENT 1

Test Methods for Evaluating Solid
 Waste - Physical/Chemical Methods, SW-846

Metal/material	Digestion test method number
All metals, except Chromium (VI)	3050
Chromium (VI)	3060

Metal/Material	SW-846 Analysis test method number
Antimony	7040 or 7041
Arsenic	7060 or 7061
Barium	7080 or 7081
Cadmium	7131
Total chromium	7190
Chromium (VI)	7195, 7196 or 7197
Lead	7421
Mercury	7470 or 7471
Nickel	7520 or 7521
Selenium	7740 or 7741
Silver	7760 or 7761

Methods for Chemical Analysis of Water
 and Waste, EPA-600/4-020, USEPA, 1979

Metal/material	Test method number
Beryllium	210.1 or 210.2
Cobalt	219.1 or 219.2
Copper	220.1 or 220.2
Fluoride	340.1, 340.2 or 340.3
Molybdenum	246.1 or 246.2
Thallium	279.1 or 279.2
Vanadium	286.1 or 286.2
Zinc	289.1 or 289.2

4.6.6.1 Tantalum and tungsten content. Determine the tantalum and tungsten content of the enamel using any appropriate spectroscopy test method. Conduct the tests in accordance with the instrument manufacturer's directions for the use of the instrument. Manufacturer is responsible for establishing data supporting the test method choice and analytical accuracy. The test results for tantalum or tungsten shall be in conformance with the requirements of 3.5.4.

4.6.7 Yellowness. Determine yellowness index of test paint in accordance with ASTM E 313. One test panel will be exposed to normal laboratory conditions of lighting, temperature and humidity. The second test panel shall be wrapped in light impervious paper and stored at ambient laboratory conditions in an enclosed space away from light for 12 months. After aging, determine yellowness index. Test results shall be in accordance with the requirements of 3.5.7.

4.6.8 Mixing properties. Thoroughly mix by hand (do not use paint shaker) in accordance with contractor's instructions. Place 130 g of the material in a 225 g glass jar and do not agitate or disturb for 2 hours. At the end of this period, examine for compliance with 3.6.2.

4.6.9 Spraying properties. Mix the coating in accordance with contractor's instructions. Spray on a test panel to a dry film thickness between 0.050 mm and 0.075 mm and observe for spraying properties in accordance

MIL-PRF-24596A(SH)
w/INT. AMENDMENT 1

with method 4331.1 of FED-STD-141. For referee test, use automatic application in accordance with method 2131.1 of FED-STD-141. Test results shall be in accordance with the requirements of 3.6.3.

4.6.10 Brushing properties. Apply the coating to a 150 by 300 mm Leneta chart (are equivalent), using a 75-mm brush, and observe for brushing properties in accordance with method 4321.2 of FED-STD-141. Test results shall be in accordance with the requirements of 3.6.4.

4.6.11 Flexibility. Determine flexibility on two test panels in accordance with method 6221 of FED-STD-141, using a 3.2 mm mandrel. Test results shall be in accordance with the requirements of 3.6.5.

4.6.12 Knife test. Perform the knife test in accordance with method 6304.1 of FED-STD-141, using a flat portion of one panel from the flexibility test. Any commercial sharp pocket, craftsman, razor, etc. knife may be used for the test. Test results shall be in accordance with the requirements of 3.6.6.

4.6.13 Water resistance (Does not apply to grades A and B water base coatings). Using primed test panels, spray the coating to a wet film thickness specified by the manufacturer and allow the coating to air dry 48 hours. After the final coat of the system has been applied, air dry 30 days. Coat all exposed surfaces. The panel shall be laid flat and sponges wet with distilled water shall be laid on the panel in a manner to cover the full face of the test panel. The sponges shall be kept wet for a period of 7 days at ambient laboratory conditions. The sponges may be covered, but such covering shall not be restrict all evaporation. Evaporation will leach water soluble materials from the paint into the sponge. On removal of the sponge(s), observe the panel for ASTM D 1308 effects after 2 and 24 hours. Test results shall be in accordance with the requirements of 3.6.7.1.

4.6.14 Hydrocarbon fluid resistance. (Does not apply to grades A and B water base coatings). Using primed test panels, spray the coating to a wet film thickness specified by the contractor, and allow the coating to air dry 48 hours. After the final coat of the system has been applied, air dry 30 days. Coat all exposed surfaces. The test panel shall be laid flat and sponges wet with commercial kerosene or jet fuel shall be laid on the panel in a manner to cover the full face of the test panel. The sponge shall be kept wet for a period of 24 hours at ambient laboratory conditions. The sponges may be covered to restrict evaporation. On removal of the sponge, observe the panel for ASTM D 1308 effects. Test results shall be in accordance with the requirements of 3.6.7.2.

4.6.15 Salt spray resistance. (Does not apply to applications C, D and E coatings). Using primed steel test panels, spray the coating to a wet film thickness specified by the contractor, and allow the coating to air dry 48 hours. After the final coat of the system has been applied, air dry 30 days. Coat all exposed surfaces. Expose the unscored panels to 5 percent salt spray for 14 days in accordance with ASTM B 117. Upon removal, wash the panels gently in warm running water (not more than 38°C) until free from any visible salt deposits and examine immediately in accordance with ASTM D 610. Test results shall be in accordance with the requirements of 3.6.7.3.

4.6.16 Condensation blister resistance.

4.6.16.1 Using primed test panels, spray the coating to a wet film thickness specified by the contractor, and allow the coating to air dry 48 hours. After the final coat of the system has been applied, air dry 30 days. Coat all exposed surfaces. The test shall be conducted in accordance with ASTM D 2247 for 100 hours. Evaluation will be conducted and blisters rated in accordance with ASTM D 714. Test results shall be in accordance with the requirements of 3.6.7.4.

4.6.16.2 Condition the panel under ambient laboratory conditions for 48 hours. Test in accordance with 4.6.21.2 for flame spread properties. Test results shall be in accordance with the requirements of 3.7.1.

4.6.17 Exudate formation (grades A and B water base coatings only). Two test panels shall be prepared in accordance with 4.5.3. Immediately after spraying, the test panels shall be placed in a cool place (2°C to 7°C) for 24 hours. After 24 hours, examine film surface for liquid residues and tackiness. Test results shall be in accordance with the requirements of 3.6.8.

MIL-PRF-24596A(SH)
w/INT. AMENDMENT 1

4.6.18 Washability. Washability shall be determined in accordance with method 6141.1 of FED-STD-141. Test results shall be in accordance with the requirements of 3.6.9.

4.6.19 Flash rust resistance (grades A and B, application A water base paints only). Spray apply one coat of the test paint to unprimed, degreased, bare steel panels. Allow to dry overnight at ambient laboratory conditions. Inspect for rust spotting. Test results shall be in accordance with the requirements of 3.6.10.

4.6.20 Recoatability. Prepare 5 test panels by applying the paint to a nonporous substrate to the recommended film thickness. Four of the test panels shall be heated in an oven for 7 days at 38 °C to 43 °C. One panel shall be aged at ambient conditions for the period recommended by the manufacturer before overcoating and then overcoated with itself to the manufacturer's recommended wet film thickness. The 4 oven dried panels shall be individually overcoated with one of the following: (a) the originally applied paint, (b) a waterbased coating qualified to this specification, (c) a solvent based paint qualified to this specification and (d) paint in conformance with MIL-DTL-24607. Allow all recoated panels to dry at least 48 hours at normal laboratory conditions. Inspect dry overcoated paint film for wrinkling, blistering or lifting of the test paint film. When dry, cut with a knife blade and inspect overcoat for loss of and for flaking away from the test paint film. Inspect the surface of the recoat for smoothness, blistering and uncoated areas. Test results shall be in accordance with the requirements of 3.6.13.

4.6.21 Thermal properties.

4.6.21.1 Painting of test specimens. Primed test specimens shall be painted to either: (a) 0.76 mm dry film thickness in at least two, but not more than four coats to achieve the thickness or (b) to that thickness and number of coats recommended by the manufacturer in the product data sheet. Final coating thickness shall be whichever of these values is greater. If multiple coats are required to achieve the test thickness, at least 24 hours, but no more than 48 hours, shall lapse between coats. Fully coated test specimens shall be aged 14 days before testing. Application of test coatings may be by brush, roller, or spray. Test specimens, unless otherwise specified in the specific test method, shall be of material corresponding to the application for which qualification is being sought.

4.6.21.1.1 Test samples prepared in accordance with 4.6.21.1 shall be immersed in distilled water for 48 hours. After drying, test samples in accordance with 4.6.21.2 through 4.6.21.6.

4.6.21.2 Radiant panel test. The radiant panel test shall be conducted in accordance with ASTM E 162. Test panels shall be prepared in accordance with 4.6.21.1. In addition, intumescent paints applied to the appropriate substrate for which qualification is sought shall be observed for the degree of intumescence expressed as a percent of the original dry film thickness. Test results shall be in accordance with the requirements of 3.7.1.

4.6.21.3 Smoke density chamber test. This test shall be conducted in accordance with ASTM E 662 in both burning and non-burning modes for smoke density and flashover. The test sample appropriate to the application for which qualification is sought shall be prepared in accordance with 4.6.21.1 on an applicable substrate. Substrates shall be primed where appropriate. Test results shall be in accordance with the requirements of 3.7.2.

4.6.21.4 Resistance to ignition. The test shall be conducted in accordance with appendix A. Test results shall be in accordance with the requirements of 3.7.3.

4.6.21.5 Flashover determination. The occurrence and time of flashover shall be determined in accordance appendix B. Test results shall be in accordance with the requirements of 3.7.4.

4.6.21.6 Heat transfer. The occurrence and time of flashover shall be determined in accordance with appendix C. Test results shall be in accordance with the requirements of 3.7.5.

4.7 Inspection of packaging. The packaging, packing and marking of the paint shall be examined to determine compliance with the requirements of the contract.

MIL-PRF-24596A(SH)
w/INT. AMENDMENT 1

5. PACKAGING

5.1 Packaging. For acquisition purposes, the packaging requirements shall be as specified in the contract or order (see 6.2). When actual packaging of materiel is to be performed by DoD personnel, these personnel need to contact the responsible packaging activity to ascertain requisite packaging requirements. Packaging requirements are maintained by the Inventory Control Point's packaging activity within the Military Department or Defense Agency, or within the Military Department's System Command. Packaging data retrieval is available from the managing Military Department's or Defense Agency's automated packaging files, CD-ROM products, or by contacting the responsible packaging activity.

6. NOTES

(This section contains information of a general or explanatory nature that may be helpful, but is not mandatory.)

6.1 Intended use. These coatings are intended for application as a non-flaming, fire-protective coating for steel, aluminum, and nonmetallic substrates. Wherever possible when used on metals, the coating should be applied over a surface that has been cleaned and primed to promote adhesion and serviceability.

6.1.1 The paints qualified to this specification will neither actively support combustion nor contribute to the spread of a fire.

6.1.2 Type I, class 2 materials are designed for use in the enclosed volume of a submarine and are compatible with the operation of the atmosphere control system (emission of volatiles and thermal degradation products). class 3 coatings are specifically designed for use while a submarine is submerged and underway.

6.1.3 Type II materials are intended to be used where it is desired to actively protect a substrate in a fire environment.

6.1.4 The paint described by this specification is military unique because of the requirements that the paint be non-burning, non-hazardous, and low-smoke producing when applied to metals. Commercial products are not designed for application to metals, but are intended for use on wood or plaster board.

6.2 Acquisition requirements. Acquisition documents must specify the following:

- (a) Title, number, and date of the specification.
- (b) Type, class, grade and application and color of coating (see 1.2 and table I).
- (c) Issue of DoDISS to be cited in the solicitation, and if required, the specific issue of individual documents referenced (see 2.2.1 and 2.3).
- (d) Packaging requirements (see 5.1 and 6.7).
- (e) Is Material Safety Data Sheet required? (see 6.4)

6.3 Qualification. With respect to products requiring qualification, awards will be made only for products which are, at the time of award of contract, qualified for inclusion in Qualified Products List QPL No. 24596 whether or not such products have actually been so listed by that date. The attention of the contractors is called to these requirements, and manufacturers are urged to arrange to have the products that they propose to offer to the Federal Government tested for qualification in order that they may be eligible to be awarded contracts or purchase orders for the products covered by this specification. Information pertaining to qualification of products may be obtained from Naval Sea Systems Command, 03R4, 2531 Jefferson Davis Highway, Arlington, VA 22242-5160.

6.3.1 Department of Defense Single Stocking Point (DODSSP). Copies of "Provisions Governing Qualification SD-6" may be obtained upon application to Department of Defense Single Stocking Point (DODSSP), BLDG. 4D, 700 Robbins Avenue, Philadelphia, PA 19111- 5094.). As of the issue date of revision A, the DODSSP help desk telephone number is (215) 697-6396/6257; the DODSSP fax number is (215) 697-2569, and the World

MIL-PRF-24596A(SH)
w/INT. AMENDMENT 1

Wide Web (WWW) address is www.dodssp.mil. Copies of the above federal specifications and documents are also available from the General Services Administration, GSA-FSSB (3FBP-W), Suite 8100, 470 L'Enfant Plaza, SW, Washington, DC 20407, telephone (202) 619-8925.

6.3.2 Class 3 qualification. Class 3 products supplied under this specification must: (a) comply with the requirements of Naval Sea Systems Command (NAVSEA) NAVSEA S9520-AB-ATM-010/(U), the Naval Ships' System Command (NSTM) Submarine Atmosphere Control manual. Since the requirements are classified, the Naval Sea Systems Command will conduct testing of class 3 products. Written requests for information regarding testing, contact the Naval Sea Systems Command, O3R42 (2531 Jefferson Davis Highway, Arlington, VA 22242-5160). Additional points of contact for information are: (a) NAVSEA 03M1 (phone 701-602-0214), (B) PMS-390 (phone 703-746-3323), and (c) NAVSEA 56Y14 (phone 703-692-5473).

6.3.3 Navy Formula 25A. The required formulation of Navy Formula 25A may be obtained upon application to Naval Sea Systems Command, Corrosion Control Division (NAVSEA 03M1), 2531 Jefferson Davis Highway, Arlington, VA 22242-5160 (Telephone: 703-602-0214, Telefax: 703-602-0247).

6.4 Material Safety Data Sheets. Contracting officers will identify those activities requiring copies of completed Material Safety Data Sheets prepared in accordance with FED-STD-313. Additional required government information is contained in FED-STD- 313. In order to obtain the MSDS, federal acquisition regulation (FAR) clause 52.223-3 must be in the contract. The contracting activity should be provided a material safety data sheet (MSDS) at the time of contract award. The MSDS should be included with each shipment of the material covered by this specification.

6.4.1 Product user information sheets. Users of coatings procured to this specification need information on the proper use, storage and disposal of these materials. Contracting officers should identify those activities requiring copies of completed product use sheets prepared in accordance with ASTM F 718. In order to obtain these documents, an appropriate federal acquisition regulation (FAR) clause must be in the contract.

6.5 Volatile content. Coatings to this specification may be used anywhere else a product complying with 1.2 is allowed. This includes other air pollution control districts or similar areas controlling the emission of solvents volume into the atmosphere under volatile organic content (VOC) regulations.

6.6 The coating covered by this specification should be purchased by volume, the unit being 4 L or one U.S. liquid gallon (231 cubic inches) at 20°C.

6.7 Suggested packaging. Recommended packaging requirements are provided in tables VI and VII.

MIL-PRF-24596A(SH)
 w/INT. AMENDMENT 1

TABLE VI. Packaging.

Packaging	Recommended requirements for direct Government acquisitions
Commercial packaging	<p>(1) Commercial packaging should be to ASTM D 3951.</p> <p>(2) All containers should comply with the requirements of the Uniform Freight Classifications (UFC), the National Motor Freight Classification (NMFC), and the applicable requirements of the Code of Federal Regulations 49CFR, Department of Transportation (DOT).</p>
Containers	<p>(1) Two component materials should be furnished in cans appropriate to kit requirements capable of holding 0.47 liters (L), 0.945L, 3.78L and 18.9L. Kits should consist of two containers, one of which should be larger enough to contain all components for mixing purposes.</p> <p>(2) Multiple friction plug containers should be in accordance with PPP-C-96, type V, class 2. Interior coatings should be as specified therein. Exterior coatings, including side seam stripping, should be as specified therein for plan B. Wire handles as specified therein, should be provided for the 3.78L container. Closure of the properly filled and sealed cans should be as specified in the appendix thereto. Pails should be to PPP-P-704.</p> <p>(3) All containers should comply with the requirements of the Uniform Freight Classifications (UFC), the National Motor Freight Classification (NMFC), and the applicable requirements of the Code of Federal Regulations 49 CFR, Department of Transportation (DOT).</p> <p>(4) Container lining: Solvent-resistant baked phenolic lining materials have been successfully used in containers for paints covered by this specification. The paint, as specified herein, may gel if stored in contact with metal. In properly lined containers, however, the coating is stable for over 2 years.</p> <p>(5) Unit of procurement: The paints covered by this specification should be purchased by volume. The unit of procurement should be in multiples of 1 L or 1 U.S. liquid gallon at 15.5°.</p>
Packing	<p>Packing should be specified as follows:</p> <p>(1) Overseas delivery (Level A) packing. Intermediate containers of like size kit intermediate containers of paint should be packed in close-fitting wood boxes conforming to PPPB- 601, overseas type, or PPP-B-621, class 2. Box closure and strapping should be as specified in the applicable box specification or the appendix thereto except that strapping should be flat and the finish B.</p> <p>(2) Domestic delivery (Level B) packing. Level B packing should be as for level A, except that boxes should be domestic type or class and the strapping should be finish A or B.</p> <p>(3) Commercial packing. The paint, in the unit kit and intermediate containers should, as applicable, be packed in multiples of like sizes in accordance with UFC, NMFC and 49 CFR 178 requirements.</p>
Palletization	Intermediate containers should be palletized in accordance with MIL-STD-147. Only one size unit or intermediate container should be placed on a pallet.
Intermediate Containers	Paints should be packaged in intermediate containers. Intermediate containers should be close-fitting corrugated fiberboard boxes in accordance with UFC, NMFC and 49CFR requirements. Fiberboard used in the construction of interior (unit and intermediate) and exterior containers, including interior packaging forms, should conform to the PPP-F-320. PPPF-320 classes should be domestic fire-retardant or weather resistant fire-retardant (see 6.2).

MIL-PRF-24596A(SH)
 w/INT. AMENDMENT 1

Packing for Acquisitions involving direct delivery to Navy ships or installations	Treated lumber and plywood. All lumber and plywood, including laminated veneer materials, used in shipping container and pallet construction, member, blocking, bracing, and reinforcing must be fire-retardant treated material in accordance with MIL- 19140 as follows:
Material safety data sheets (MSDS) and Product / procedure data sheets	A copy of the MSDS and company product data/procedure sheets should be attached to the shipping document for each destination (see 6.3).
Marking type	Recommended Marking
Packing for Acquisitions involving direct delivery to Navy ships or installations - Continued	(a) General use, weather resistant: MIL-L-19140, type II, Category I. (b) General use, non-weather resistant: MIL-L-19140, type I, Category I.
Bar codes	Marking should include bar codes
Hazardous warnings	(a) Labels should be in accordance with 29 CFR Parts 1910, 1910.1200, 1915, 1917, 1918, 1926 and 1928, as well as PPP-P-1892. (b) All individual containers should have the following marking: “CAUTION: This paint contains volatile solvents, with probable hazardous vapors. Use with adequate ventilation. Avoid prolonged breathing of vapors or spray mists. The solvents are highly flammable, avoid open flame and smoking.” (c) Each component container, shipping container, and palletized load should be marked with the appropriate hazardous symbol in accordance with FED-STD-313.
Volatile organic content (VOC)	“Contains (Insert VOC content) grams per liter of volatile organic content per 40 CFR CH.1, part 60, Appendix A (EPA) Method 24.”
VOC certification sheets	VOC certification sheets for each batch of coating will be provided when requested by the procuring activity.
Shelf life	Each unit container, intermediate container where applicable, and shipping container should be marked as follows: “Date of first re-inspection (insert here date 3 years after date of manufacture).”

6.8 Subject term (key word) listing.

- Nonflaming
- Fire-protective
- Water base
- Volatiles
- Non-intumescent
- Intumescent

6.9 Amendment notations. The margins of this specification are marked with vertical lines to indicate modifications generated by this amendment. This was done as a convenience only and the Government assumes no liability whatsoever for any inaccuracies in these notations. Bidders and contractors are cautioned to evaluate the requirements of this document based on the entire content irrespective of the marginal notations.

MIL-PRF-24596A(SH)
w/INT. AMENDMENT 1

APPENDIX A

RESISTANCE TO IGNITION

A.1 SCOPE

- A.1.1 Scope. This procedure determines whether a paint will ignite into flames when the sole ignition source is the heated metallic substrate to which the paint adheres. This Appendix is a mandatory part of the specification. The information contained herein is intended for compliance.
- A.1.2 The test yields information on the ability of the coating to resist auto-ignition, running and dripping when subjected to a very rapid heat rise and information on the ability of the paint to resist spread of the flame across the test specimen, as well as the tendency of a paint to ignite secondary fires by flaming drips.
- A.1.3 The conditions of the test have been standardized so that paints passing this test may be safely used on ships' bulkheads and overheads where nonflaming paints are required to prevent fires from spreading from one sealed compartment to the next during a severe shipboard fire.

A.2 APPLICABLE DOCUMENTS

This section is not applicable.

A.3 TEST APPARATUS

- A.3.1 Test apparatus. The recommended apparatus consists of a high amperage direct current (d.c.) generator capable of 300 to 400 amps, electrodes for holding the test specimen, an ammeter attached across a in-line shunt, a voltmeter, and a switch capable of handling the voltages and currents involved. The wiring diagram is shown on figure A-1. The current from the d.c. generator is shunted directly through the test specimen to cause rapid heating. 3/0 stranded welding cable is recommended for wiring.

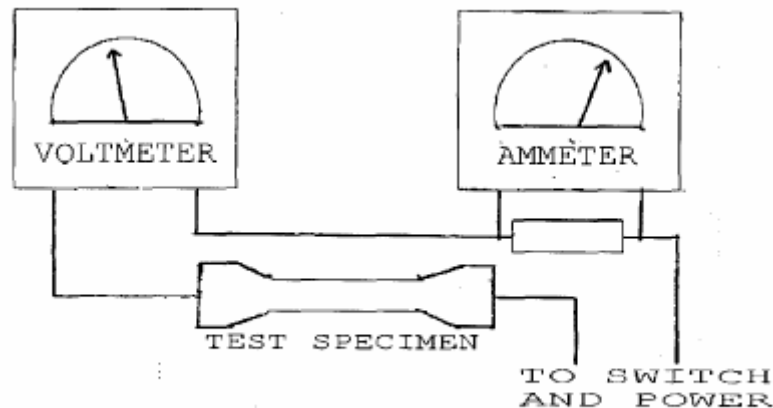

FIGURE A-1. Wiring diagram.

- A.3.1.1 The test apparatus shall be arranged in a shielded cabinet or room to reduce air current effects. Air moving past the specimen shall be regulated to that caused only by convection heating of the test specimen.
- A.3.2 Test panels preparation. Test specimens shall be coated to either 0.15 mm dry film thickness in as many coats as necessary to achieve 0.15 mm or to that thickness recommended by the manufacturer's data sheet, whichever is greater. If multiple coats are required to achieve the test thickness, at least 24 hours, but no more than 48 hours shall lapse between coats. Fully coated test specimens shall be aged 14 days before being tested.

MIL-PRF-24596A(SH)
w/INT. AMENDMENT 1

A.4 PROCEDURE

A.4.1 Test procedure. Using a test specimen (figure A-2 provides recommended specimen) made of mild steel, the apparatus is calibrated to give a temperature rise in the test specimen of 1000°C in 60 seconds of the start of the test. A timing device accurate to one second shall be used to determine test duration. The test specimen shown in figure A-2 is recommended and has been used by most testing organizations. The only required dimensions is that the center narrow bar shall not be less than 150 mm in length, 25 mm in width and not less than 1.6 mm thickness. The 1.6 mm or greater thickness will allow the full time of test without the test bar burning through.

A.4.1.1 Calibration of temperature. Calibration of the 1000°C in 60 seconds time - temperature curves for the particular test specimens and power source shall be conducted. The time-temperature curve is determined by the cross section and resistivity of the actual test specimens used. Temperature indicating crayons, temperature indicating paints or optical pyrometers are recommended. Thermocouples are not recommended due to the current flowing in the test specimen.

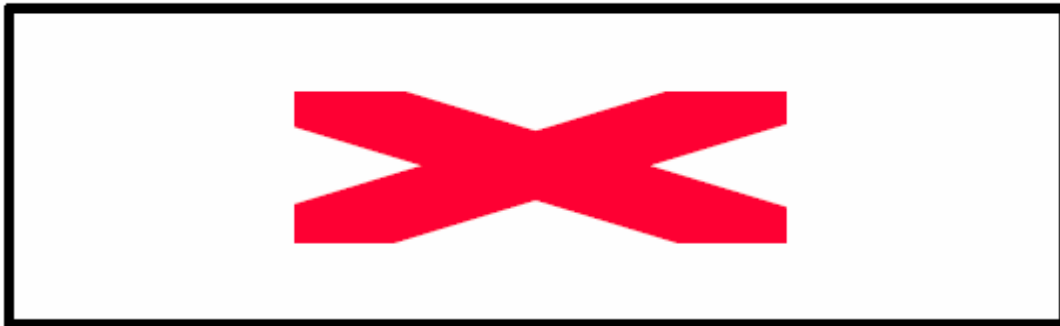

FIGURE A-2. Test specimen.

A.4.2 Data acquisition. The test specimen shall be observed and data recorded for:

- A.4.2.1 Flaming (ignition) of the paint before reaching 1000°C.
- A.4.2.2 Fumes or smoke from the paint and the time at which fumes/smoke began.
- A.4.2.3 Volume of smoke (light moderate or heavy).
- A.4.2.4 Other characteristics, such as sloughing, dripping, softening, or color changes.
- A.4.2.5 Color slides shall be taken during and after the test, particularly at the time of ignition and at the point of maximum involvement, and after the completion of the test.

A.4.3 Data analysis. The performance of the test paint is then compared to the performance of MIL-DTL-24607 tested at 150 μ thickness when prepared and tested under identical conditions. Test results shall be in accordance with the requirements of 3.6.8.

A.5 SUMMARY

A.5.1 This test procedure provides a relatively simple, straightforward and reproducible method to determine the ignition potential of materials used to paint the interior surfaces of a compartment. In addition, important data on the reaction of the paint to heating of the substrate is determined. The fact that the data is of a “go” or “no-go” form makes the error of operation relatively small.

MIL-PRF-24596A(SH)
w/INT. AMENDMENT 1

APPENDIX B

DETERMINATION OF THE FLASHOVER POTENTIAL OF A LINING
MATERIAL USING A QUARTER-SCALE COMPARTMENT FIRE TEST

B.1 SCOPE

- B.1.1 Scope. This method describes a procedure to determine the flashover potential of materials in a room when subjected to a fire exposure. This Appendix is a mandatory part of the specification. The information contained herein is intended for compliance.
- B.1.2 The method described will yield a time from the introduction of the fire exposure until the moment of flashover and the presence of hazardous chemicals in the combustion products.
- B.1.3 Definition. In the interest of reducing both the setup time and cost associated with fire testing in a full size room, herein defined as a 3 m by 3 m by 2.4 m high room having a 750 mm by 2030 mm high doorway, a one-quarter scale room fire test was devised to predict flashover potential of lining materials exposed to fire.

B.2 APPLICABLE DOCUMENTS

This section is not applicable.

B.3 TEST APPARATUS (All dimensions are nominal.)

- B.3.1 Test structure. The quarter-scale room (figure B-1) shall be constructed from steel with a covering of a suitable ceramic insulation board. The structure shall form an airtight box having a ceiling and four sides. The box shall sit on a floor fabricated with the same material. The interior dimensions of the fully lined quarter-scale room are 750 by 750 by 600 mm high. The doorway is located at the center of one wall and shall be 495 mm wide and 425 mm high to secure the proper ventilation and fire development. The height between the finished ceiling and the top of the doorway shall be 175 mm. The floor of the model room shall extend at least 300 mm outside of the doorway. The box shall be removable to allow for application of paint and ceiling and wall covering. The entire base of the box in contact with the floor shall be made airtight.
- B.3.2 Flame, heat source. A porous plate diffusion flame burner shall be used as the fire source. The burner shall be 90 by 90 by 75 mm high, consisting of a horizontal porous plate area of 75 by 75 mm with a 6-mm wide steel plate perimeter and steel plate sides and bottom.

MIL-PRF-24596A(SH)
w/INT. AMENDMENT 1

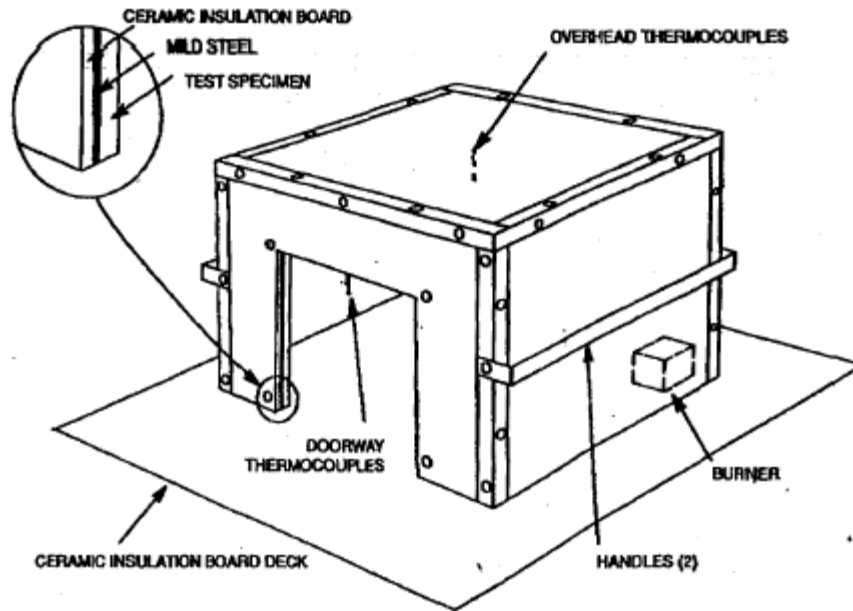

FIGURE B-1. Quarter scale model.

B.3.3 Thermocouple material and location. Four 250 mm chromelalumel thermocouples shall be used, 25 mm and 75 mm below the center of the overhead and 25 mm and 50 mm below the top of the doorway.

B.4 PROCEDURE

- B.4.1 The walls (bulkheads) and ceiling (overhead) shall be fully covered by material of the appropriate application. The test substrate shall be primed and painted to either: (a) 0.75 mm to 0.87 mm dry film thickness in at least two, but not more than four coats to achieve the minimum 0.75 mm or (b) to that thickness which the contractor recommends. Final coating thickness shall be whichever of these values is greater. If multiple coats are required to achieve the test thickness, at least 24 hours, but no more than 48 hours, shall lapse between coats. Fully coated test substrate shall be aged 14 days. Application of test coatings may be by brush, roller, or spray.
- B.4.2 Prior to testing, the fully-lined test room shall be conditioned for at least 24 hours at a relative humidity between 20 and 60 percent, and a temperature of $23 \pm 5^\circ\text{C}$.
- B.4.3 The fire source shall be positioned on the floor snugly against one rear corner of the test room. Adjust the flow rate (approximately 0.0091 m³/min) of methane to produce a constant heat input of approximately 336 joules per minute (J/min) for the duration of the test.
- B.4.4 The test data from the four thermocouples shall be recorded as a continuous function of time.
- B.4.5 The primary data generated by this test will be the time to flashover if it occurs, and the maximum temperature if flashover does not occur. Flashover is characterized by thermal flux levels equal to or greater than 2 watts per square centimeter (W/cm²) at the floor level. This corresponds to interior temperatures of 600°C and higher, and doorway temperatures of 500°C and higher. For the purpose of qualification acceptance, flashover is defined as the fire condition where one of the interior thermocouple measurements reach 600°C or one of the doorway measurements reach 500°C, whichever occurs first. For qualification acceptance of the material, flashover shall not occur within 10 minutes.
- B.4.6 The evolution of toxic gases shall be detected and reported using appropriate air sampling techniques. The presence of HCN, HCl, CO₂, and CO shall be reported, if detected, in parts per million (ppm).
- B.4.7 Color slides shall be taken before the test, at the point of maximum involvement, and after the fire has been extinguished.

B.5 SUMMARY

MIL-PRF-24596A(SH)
w/INT. AMENDMENT 1

- B.5.1 This quarter-scale room test procedure provides a relatively simple, straightforward and reproducible method to determine the flashover potential of materials used to line the interior surfaces of a compartment. The lining materials may be insulation, paint (used over lining materials), sheathing, acoustic panels or the like. In addition, important data on the generation of toxic gases and the suppression of toxic gases can be derived. The fact that the data is of a “go” or “no-go” form makes the error of operation relatively small.

MIL-PRF-24596A(SH)
w/INT. AMENDMENT 1

APPENDIX C

HEAT TRANSFER TEST

C.1 SCOPE

C.1.1 Description. This test method describes a test procedure for determining the length of time for the unheated side of an aluminum test specimen coated with type II coatings to reach 232°C when the coated side is exposed to a 147 kW (500,000 BTU/hour) burner having a 1095°C flame. This Appendix is a mandatory part of the specification. The information contained herein is intended for compliance.

C.1.2 Results. This test provides data on the insulating effect provided by intumescent coatings.

C.2 APPLICABLE DOCUMENTS

This section is not applicable to this document.

C.3 TEST APPARATUS

C.3.1 Fire chamber. A fire test assembly consisting of a fire chamber and its associated plate shall be constructed as shown in figure C-1. All dimensions are nominal.

C.3.1.1 Fire chamber. The fire chamber shall be constructed from 16 gauge (nominal; minimum) mild steel. The chamber shall be approximately 1 m on a side. A 0.09 m² opening shall be fabricated on one side to serve as an air inlet and viewing port. The back of the chamber shall be open to accommodate a propane burner. The burner shall be mounted 460 mm from the coated specimen. A 660 mm wide by 380 mm deep sliding door located on the top of the chamber shall be provided to permit adjustment of air flow and burner temperature. The chamber shall be provided with a flange with bolt holes on the test plate end to which the test plate assembly can be mounted.

C.3.1.2 Test plate assembly. The plate assembly shall be large enough that the fire chamber can be bolted to the face approximately 1.2 m². The plate shall provide mounting holes corresponding to those on the fire chamber flange. In the center of the test plate assembly there shall be a circular opening approximately 420 mm in diameter. Bolt holes shall be provided for mounting the coated test specimen.

C.3.1.3 Gasket. A high temperature, non-combustible felt gasket at least 12 mm thick shall be provided between the coated plate assembly and the painted test panel.

MIL-PRF-24596A(SH)
w/INT. AMENDMENT 1

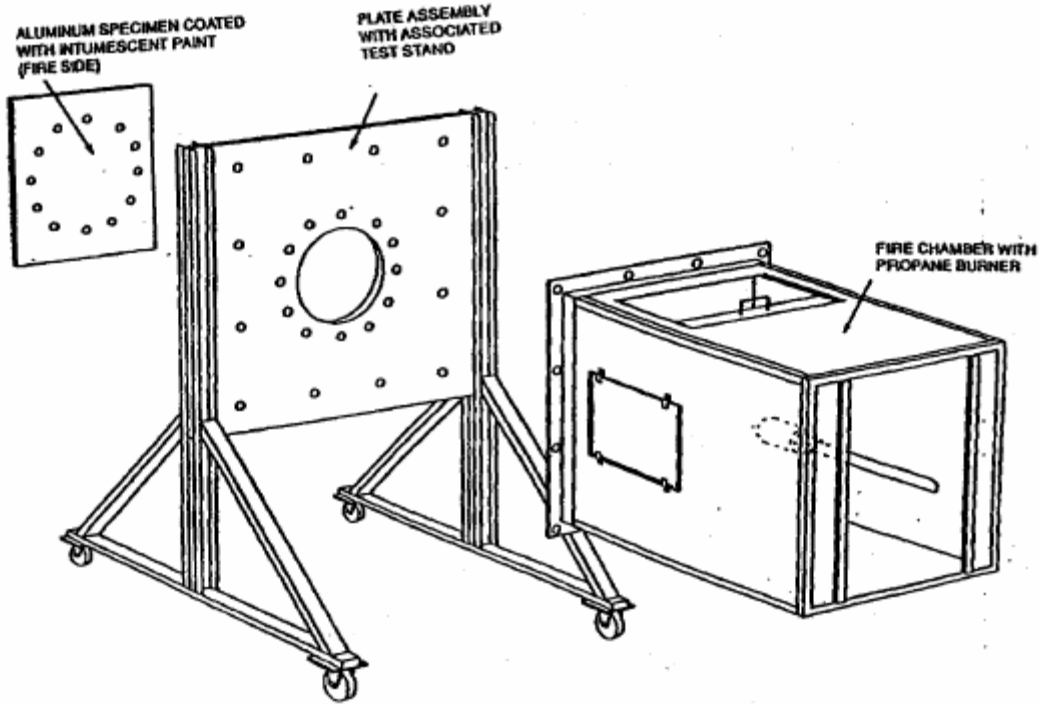

FIGURE C-1. Exploded view of 147 kilowatt fire test assembly.

- C.3.1.4 Test specimen. The test specimen shall be large enough for mounting on the plate assembly and be of aluminum at least 6 mm thick. Only one face of the plate is coated.
- C.3.2 Propane burner. A propane burner having a 147 kilowatt (kW) (500,000 BTU/hr) flame with at least a 30 minute fuel reservoir shall be used. The temperature of the flame and the fire side of the specimen shall be 1000°C to 1200°C.
- C.3.3 Thermocouples (T/C). The temperature of the uncoated (back) side of the aluminum shall be measured using thermocouples (Inconel sheathed, type K, 1.3 mm diameter chromel-alumel is recommended). The time constant of the T/C assemblies shall be less than 60 seconds and the T/C accuracy shall be plus or minus 0.75 percent. At least 8 T/Cs shall be positioned on the remote (uncoated, back) side of the test specimen in accordance with figure C-2. One T/C shall be mounted on the painted side to verify flame temperature.

MIL-PRF-24596A(SH)
 w/INT. AMENDMENT 1

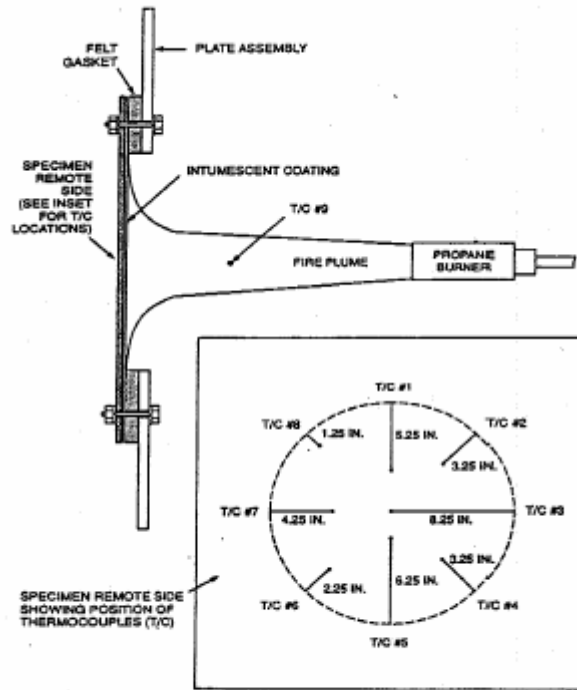

FIGURE C-2. Thermocouple locations.

C.4 PROCEDURE

- C.4.1 The airflow in the chamber in the test chamber shall be adjusted to provide a flame and the fire side of 1000 C to 1200 C throughout the test.
- C.4.2 Mount and bolt the coated test panel and gasket to the test plate assembly.
- C.4.3 Mount and bolt the fire chamber to the test plate assembly. Adjust the tip of the burner to 460 mm from the coated test specimen.
- C.4.4 Ensure all thermocouples are functioning.
- C.4.5 Ignite the burner. The flame shall be applied to the test specimen for not less than 15 minutes or until the test specimen burns through. Record T/C data continuous for duration of test.

C.5 REPORT

- C.5.1 Report. Test reports shall provide the following information:
 - (a) Sufficient nomenclature to identify the material tested and the manufacturer.
 - (b) The elapsed time from the start of the test to that time each remote side T/C reached 232 C, if such occurred.
 - (c) Time to burn through of the test specimen, if such occurred in tabular and graphic forms.
 - (d) Flame temperature throughout the test in tabular and graphic forms.

C.6 SUMMARY

- C.6.1 This fire test determines the insulating benefits of the intumescent char generated during a fire. This test is severe in that the flame can erode loosely adhering intumescent char from the substrate to be protected.

MIL-PRF-24596A(SH)
w/INT. AMENDMENT 1

Preparing activity:
Navy – SH
(Project 8010-2006-036)

NOTE: The activities listed above were interested in this document as of the date of this document. Since organizations and responsibilities can change, you should verify the currency of the information above using the ASSIST Online database at <http://assist.daps.dla.mil>.