

METRIC

MIL-PRF-10436N
31 OCTOBER 2003
SUPERSEDING
MIL-PRF -10436M
15 SEPTEMBER 1998

PERFORMANCE SPECIFICATION
COMPASS, MAGNETIC, UNMOUNTED:
LENSATIC, LUMINOUS, 5 DEGREE AND 20 MIL
GRADUATIONS, WITH CARRYING CASE

All Departments and Agencies of the Department of Defense approve this specification for use. The original issue of this specification replaced MIL-C-10436.

1. SCOPE

1.1 Scope. This specification covers an induction-damped, lensatic, unmounted, magnetic compass, with 5 degree and 20 mil graduations, for individual use during day and nighttime.

2. APPLICABLE DOCUMENTS

2.1 General. The documents listed in this section are specified in sections 3 and 4 of this specification. This section does not include documents cited in other sections of this specification or recommended for additional information or as examples. While every effort has been made to ensure the completeness of this list, document users are cautioned that they must meet all specified requirements documents cited in sections 3 and 4 of this specification, whether or not they are listed.

2.2 Government documents.

2.2.1 Other Government documents and publications. The following other Government documents and publications form a part of this document to the extent specified herein. Unless otherwise specified, the issues are those cited in the solicitation.

Comments, suggestions, or questions on this document should be addressed to: U.S. ARMY TOPOGRAPHIC ENGINEERING CENTER, ATTN: CEERD-TS-T, 7701 TELEGRAPH ROAD, ALEXANDRIA, VA 22315-3864 or emailed to pd-te@tec.army.mil . Since contact information can change, you may want to verify the currency of this address information using the ASSIST Online database at www.dodssp.daps.mil .

AMSC N/A

FSC 6605

DISTRIBUTION STATEMENT A. Approved for public release; distribution is unlimited.

OTHER GOVERNMENT DOCUMENTS

DEPARTMENT OF INTERIOR, U.S. GEOLOGICAL SURVEY

ISOGONIC CHARTS

Epoch 1995 Map No. GP1002-D	Magnetic Declination of the U.S.
Epoch 1995 Map No. GP1002-F	Magnetic Total Intensity of the U.S.
Epoch 1995 Map No. GP986-V	Magnetic Vertical Intensity of the U.S.
Epoch 1995 Map No. GP986-H	Magnetic Horizontal Intensity of the U.S.

(Application for copies should be addressed to Map Distribution, U.S. Geological Survey, Box 25286, Federal Center, Denver, CO 80225.)

2.3 Order of precedence. In the event of a conflict between the text of this document and the references cited herein, the text of this document takes precedence. Nothing in this document, however, will supersede applicable laws and regulations unless a specific exemption has been obtained.

3. REQUIREMENTS

3.1 Description. The compass (see Figure 1A and 1B) shall be an induction-damped, hand-held, north-seeking instrument with internal, self-exciting light source.

3.2 First article. Unless otherwise specified (see 6.2), a sample shall be subjected to first article inspection.

3.3 Design, materials, and manufacturing processes. Unless otherwise specified, the design, materials, and manufacturing processes are the prerogative of the contractor as long as all articles submitted to the government meet the operating, environmental, and support requirements specified.

3.3.1 Material deterioration prevention and control. The compass shall be fabricated from compatible materials, inherently corrosion resistant or treated to provide protection against the various forms of corrosion and deterioration to which they are susceptible.

3.4 Operating requirements.

3.4.1 Graduations. The compass shall be graduated in degrees and mils. The degree graduations shall be semi-gloss red (see 6.11) and identified at 5 degree intervals. They shall be numbered every 20 degrees, with north being 0 degrees. The north arrow may be used in lieu of the "0" degree marking. The mil graduations shall be semi-gloss black (see 6.11) and identified at 20 mil intervals. They shall be numbered every 200 mils, using only hundreds and thousands digits (i.e., 2, 4, 6, ...64 represent 200, 400, 600, ...6400 mils). North shall be identified as 6400 mils. All graduations shall be distinguishable in day and night conditions (see 4.4.1.1).

3.4.2 Scale. The compass shall have a scale of 1:50000 with graduations of 100 meters, 0 to 6000 minimum, along the length of the compass, in the opened configuration (if applicable) (see 4.4.1.2)

MIL-PRF-10436N

3.4.3 Sighting device. The compass shall have a sighting mechanism, capable of aiming the compass in day and night conditions (see 4.4.1.3).

3.4.4 Bezel. The compass shall have an attached bezel (ring with luminous line), capable of rotation through 360 degrees in either direction. Rotation shall be limited to 3 degree increments with tactile (non-audible) feedback. There shall also be means to prevent accidental movement or removal of the bezel (see 4.4.1.4).

3.4.5 Free floating assembly. When a free floating assembly is employed, the compass shall incorporate a mechanism that restricts all movement of the dial assembly when the compass is not in use, and automatically releases the dial assembly for use (see 4.4.1.5).

3.4.6 Lanyard. A neck lanyard 2.5 ± 0.5 millimeters (mm) thick with the ends permanently joined to form a loop, 150 ± 5 centimeters (cm) in circumference, shall be attached to each compass. The lanyard shall be lusterless green (see 6.11) and made from a suitable, pliable, durable material (see 4.4.1.6).

3.4.6.1 Lanyard attachment. The lanyard and compass attachment point shall withstand a force of 34 kg without damage, breakage or separation from the compass (see 4.4.1.6.1).

3.4.7 Carrying case. A carrying case shall be furnished with each compass. The case shall be a pouch made from a suitable, pliable, durable material, with a single heavy duty fastening system on the fold over flap closure. The carrying case material shall be lusterless green (see 6.11) and the fasteners shall be lusterless black (see 6.11). It shall be provided with a means for drainage and for attachment to belts 7 cm wide. The case shall be constructed for repeated use and to facilitate storage and retrieval of the compass and instruction card (see 4.4.1.7 and 4.4.3.4).

3.4.7.1 Instruction card. Instructions in semi-gloss white (see 6.11) lettering shall be printed on a semi-gloss green (see 6.11) card, 6 x 10 cm nominal size that shall not be damaged by water or moisture. One card, without being folded, shall be inserted into each compass carrying case (see 4.4.1.7.1). Additional instruction cards shall be provided as specified (see 6.2). Data, printed legibly on cards, shall be as follows:

INSTRUCTIONS:

- (1) Align luminous line on compass ring with sight lines.
- (2) Turn ring counterclockwise by desired number of clicks. Note: Number of clicks = degrees azimuth divided by 3. Example: 51 degrees azimuth / 3 = 17 clicks counterclockwise.
- (3) Turn compass until north arrow lines up with luminous line on ring.
- (4) Sight line now points to azimuth.

3.4.8 Magnetic performance. The compass shall provide magnetic performance as specified in 3.4.8.1, when operated in accordance with the instructions in 3.4.7.1. It shall be capable of being read to an accuracy that ensures an error not greater than 40 mils, in any ambient light, under adverse field conditions (see 4.4.1.8).

3.4.8.1 Magnetic standard. The compass shall operate in a magnetic field with a horizontal component equal to the local standard $\pm .01$ oersted and vertical component of the local standard $\pm .03$ oersted (Continental United States). The local standard shall be established using the U.S. Geological Survey (Department of the Interior) Epoch 1995 Map No. GP1002-D, Magnetic Declination of the U.S.; Epoch 1995 Map No. G1002-F, Magnetic Total Intensity of the U.S.; Epoch 1995 Map No. GP986-V, Magnetic Vertical Intensity of the U.S.; and Epoch 1995 Map No. GP986-H, Magnetic Horizontal Intensity of the U.S.

3.4.9 Mechanical performance. The compass shall meet the subordinate requirements with the compass in the operational configuration and away from all magnetic effects external to the compass caused by buildings, vehicles, electrical devices, etc.

3.4.9.1 Damping. The magnetic assembly, shall come to rest within 6 seconds of time after being deflected 540 ± 20 mils from a position of equilibrium (see 4.4.1.9.1).

3.4.9.2 Freedom of rotation when tilted. The operation of the compass shall not be adversely affected when it is tilted 8.0 ± 0.1 degree from the horizontal and rotated 360 degrees in a plane normal to the longitudinal axis of the pivot (see 4.4.1.9.2).

3.4.9.3 Compass error. The error in magnetic azimuth, including that caused by pivot friction, shall not be greater than 40 mils (see 4.4.1.8).

3.4.9.4 Friction error. The error caused by friction between the pivot supporting the dial and its bearing shall not be greater than 20 mils (see 4.4.1.9.3).

3.4.10 Illumination. The compass shall have internal, self-exciting light sources of constant luminosity for sighting and reading. In addition, the dial assembly shall have a light source on the permanent magnet to indicate north and the bezel crystal shall have a light source to aid in setting readings and sighting. The "E" (east) and "W" (west) markings shall also be illuminated. All sources shall be mounted flush with or recessed in their mounting surfaces and encapsulated to inhibit damage (see 4.4.1.9.4).

3.4.10.1 Luminosity. Luminous material, in the final form, shall have a peak spectral output of 530 ± 30 nanometers. The brightness of the luminous sources installed in the completed compass shall be sufficient to allow the performance of compass functions in any ambient light and under any of the environmental conditions specified herein (see 4.4.1.9.4.1). Self-exciting luminous sources shall have a minimum service life of 12 years (see 6.2).

3.5 Environmental requirements.

3.5.1 Water leakage. The complete compass shall be capable of being submerged into water without leakage into the interior of the compass, where it will adversely affect performance directly or indirectly (see 4.4.2.1).

3.5.2 Shock. The compass shall not be damaged or suffer performance degradation when dropped from a height of 90 cm (see 4.4.2.2).

3.5.3 Low and high temperatures. When exposed to temperature extremes of -44°C and 68°C , the compass shall function properly and shall not be damaged (see 4.4.2.3).

MIL-PRF-10436N

3.5.4 Thermal shock (vials only). Self-excited luminous sources shall not be damaged by thermal shock caused by sudden temperature changes of -52°C to 68°C (see 4.4.2.4).

3.6 Support requirements.

3.6.1 Dimensions and weight. The compass shall not be greater than 9 cm long, 8 cm wide and 4 cm high, in its closed or stored configuration. Its weight shall not be greater than 170 grams (see 4.4.3.1)

3.6.2 Radiological containment. If radioactive luminous light sources are used (see 3.4.10), these subordinate requirements are mandatory.

3.6.2.1 Contamination. Removable contamination activity of the completed compass shall be less than 900 disintegration rate per minute (dpm) at the time of production (see 4.4.3.2.1).

3.6.2.2 Diffusion. A completed compass with all the luminous vials installed shall not leak radioactive material in excess of 0.05 microcuries in 24 hours (see 4.4.3.2.2).

3.6.3 Impact durability of vials. If radioactive self-luminous source vials are used, the vials shall show no evidence of leakage, breaking, checking, shattering or spalling when the compass is dropped onto a hard surface (see 4.4.3.3).

3.6.4 Durability. The case, compass body, crystal, and moving parts shall meet all of the requirements that are described, herein, for a minimum service life of 12 years (see 4.4.3.4).

3.6.5 Finishes.

3.6.5.1 Wear surfaces. Any exterior surfaces subject to wear from repeated use shall be finished in a manner that produces a wear resistant semi-gloss black finish (see 4.4.3.5.1)(see 6.2)(see 6.11).

3.6.5.2 Non-wear surfaces. All other external surfaces shall be treated and painted for corrosion protection, as necessary. The finish coat shall be semi-gloss green enamel (see 4.4.3.5.2)(see 6.11).

3.6.5.3 Damping shell. The inside (visible) surfaces of the damping shell shall be treated and painted for corrosion protection. The finish coat shall be semi-gloss white enamel (see 6.11)(see 4.4.3.5.3).

3.6.6 Markings.

3.6.6.1 Identification. Lot identification shall be permanently marked on the compass, inside the cover (if applicable) to include year and month of manufacture and lot number. The top of the compass shall be marked with the identification and part number of the manufacturer, and National Stock Number (NSN) (see 4.4.3.6.1).

3.6.6.2 Radiation marking. If radioactive materials are used in the production of the compass, one of these subordinate requirements is mandatory (see 6.2).

3.6.6.2.1 Specific license marking. The bottom of the compass shall be permanently marked as required by applicable Nuclear Regulatory Commission Byproduct Materials License. It shall include the radiation caution symbol (not in color), quantity of isotope, the byproduct-materials

MIL-PRF-10436N

license number, and appropriate control instructions of the using service. A warning against disassembly shall also be included (see 4.4.3.6.2.1).

3.6.6.2.2 Marking of a license exempt item. The bottom of the compass shall be permanently marked to include the Nuclear Regulatory Commission manufacturer's identification number, XXXmCi 3H and CONTROLLED DISPOSAL REQUIRED (see 4.4.3.6.2.2 and 6.4).

4. VERIFICATION

4.1 Classification of inspections. The inspection requirements specified herein are classified as follows:

- a. First article inspection (see 4.2).
- b. Conformance inspection (see 4.3).
- c. Comparison inspection (see 6.8).

4.2 First article inspection. First article compasses shall consist of 10 completely assembled units.

4.2.1 Tests. Unless otherwise specified (see 6.2), the first article compasses shall be tested as specified in table I in the sequence presented. Failure of any test shall be cause for rejection of the first article compasses.

TABLE I. Test schedule.

Test	Verification	Requirement
Luminosity	4.4.1.9.4.1	3.4.10.1
Contamination	4.4.3.2.1	3.6.2.1
Shock	4.4.2.2	3.5.2
Low and High temperature	4.4.2.3	3.5.3
Damping	4.4.1.9.1	3.4.9.1
Freedom of rotation when tilted	4.4.1.9.2	3.4.9.2
Magnetic performance and compass error	4.4.1.8	3.4.8, 3.4.9.3
Friction error	4.4.1.9.3	3.4.9.4
Lanyard attachment	4.4.1.6.1	3.4.6.1
Durability *	4.4.3.4	3.6.4
Impact durability of vials*	4.4.3.3	3.6.3
Diffusion	4.4.3.2.2	3.6.2.2
Water leakage	4.4.2.1	3.5.1
Luminosity	4.4.1.9.4.1	3.4.10.1

- To be performed during first article testing only.

MIL-PRF-10436N

4.2.2 Examination. The first article compasses shall be examined and shall meet the requirements as specified in Table II. Presence of one or more defects shall be cause for rejection of the first article compasses.

Table II. Examination schedule for First Article and Quality Conformance

Examination	Verification	Requirements
Graduations	4.4.1.1	3.4.1
Scale	4.4.1.2	3.4.2
Sighting device	4.4.1.3	3.4.3
Bezel	4.4.1.4.	3.4.4
Free floating assembly	4.4.1.5	3.4.5
Lanyard	4.4.1.6	3.4.6
Carrying case	4.4.1.7	3.4.7
Instruction card	4.4.1.7.1	3.4.7.1
Illumination	4.4.1.9.4	3.4.10
Dimensions and weight	4.4.3.1	3.6.1
Wear surfaces	4.4.3.5.1	3.6.5.1
Non-wear surfaces	4.4.3.5.2	3.6.5.2
Damping shell	4.4.3.5.3	3.6.5.3
Identification	4.4.3.6.1	3.6.6.1
Radiation marking	4.4.3.6.2	3.6.6.2
Specific license marking	4.4.3.6.2.1	3.6.6.2.1
Marking licenses exempt item	4.4.3.6.2.2	3.6.6.2.2, 6.4

4.3 Conformance inspection.

4.3.1 Sampling. The compass sample size (see 6.9) for examination and testing shall be in accordance with the contract. A lot shall be accepted when zero defects are found and rejected when one or more defects are found. The production lot size shall be 3200 compasses, unless otherwise specified (see 6.2).

4.3.2 Tests.

4.3.2.1 Samples. Samples selected in accordance with 4.3.1 shall be tested and meet the requirements as specified in Table I. Any sample failing to pass any test shall be considered defective.

4.3.3 Examination.

4.3.3.1 Samples. Samples selected in accordance with 4.3.1 shall be examined and meet the requirements as specified in Table II.

4.3.3.2 Individual examination. Each production compass product shall be compared to an approved first article model (see 3.2) by examination in a darkroom for uniformity of light emission, proper source alignment and adhesive bonding, after the compasses have been dark adapted for a period of not less than 1 hour. The absence of light uniformity, as compared to an

MIL-PRF-10436N

approved first article model, improper source alignment or bonding shall constitute failure of that compass only. In cases of question, the luminosity of the source shall be determined as specified in 4.4.1.9.4.1. Failure of one or more sources to perform all compass functions in any ambient light and under any of the environmental conditions specified herein shall constitute failure of that compass only.

4.4 Test and examination.

4.4.1 Operating requirements validation.

4.4.1.1 Graduations. The compass graduations shall be visually examined to verify that the degrees are in semi-gloss red (see 6.11) with 5-degree intervals, the mil graduations are in semi-gloss black (see 6.11) with 20-mil intervals, and graduations are distinguishable in day and night conditions. Any deviation constitutes failure of this requirement.

4.4.1.2 Scale. The compass scale shall be visually examined to verify that it has a 1:50000 scale with 100 meters graduations, 0 to 6000 minimum, along the length of the compass, in the opened configuration (if applicable). Any deviation constitutes failure of this requirement.

4.4.1.3 Sighting device. The compass shall be aimed at a target. Inability to aim the compass at the target utilizing sighting mechanism shall constitute failure of this requirement.

4.4.1.4 Bezel. The bezel shall be rotated 360 degrees in both directions. Failure of the bezel to rotate in either directions in three-degree increments with tactile (non-audible) feedback or to restrict accidental movement or to remain attached shall constitute failure of this requirement.

4.4.1.5 Free floating assembly. The compass shall be examined in an open and closed configuration. The restraining mechanism shall be tested by hand shaking the closed compass; rattling of the floating dial assembly shall constitute failure of this requirement. Then, the compass shall be opened to a reading position; failure of the restraining mechanism to release the dial assembly shall constitute failure of this requirement.

4.4.1.6 Lanyard. The neck lanyard shall be examined to verify that the thickness is 2.5 ± 0.5 mm and the ends are permanently joined to form a loop of 150 ± 5 centimeters (cm) in circumference, and that the material is a suitable, pliable, durable material of lusterless green (see 6.11). Failure of this examination constitutes failure of this requirement.

4.4.1.6.1 Lanyard attachment. The assembled compass shall be fixed in an apparatus able to withstand the forces to be applied that will not hinder or support the attachment of the lanyard. A minimum tensile force of 34 kilograms shall be applied to the attached lanyard, at a point where the force is exerted on both the joint forming the loop and the point of attachment to the compass. Any damage or breakage of the lanyard or compass shall constitute failure of this test.

4.4.1.7 Carrying case. The carrying case shall be examined to verify that the material is pliable and durable and the color is lusterless green (see 6.11). In addition, verify that the case has a heavy-duty lusterless black (see 6.11) fastening system on the flap enclosure, a means for drainage, and a 7 mm belt attachment. The compass shall be placed in the case and the case flap fastened and unfastened. Then the compass shall be removed from the case to verify ease of storage and removal. There shall be no snags or tightness within the case, which prevents the compass from slipping in and out easily. Failure of this examination constitutes failure of this requirement.

4.4.1.7.1 Instruction card. The instruction card shall be examined to verify that the instructions are correct; the lettering is semi-gloss white (see 6.11); the card is semi-gloss green (see 6.11) and 6 x 10 cm, nominal size; the card is water or moisture resistant; and that one unfolded card fits in the compass carrying case. Failure of this examination constitutes failure of this requirement.

4.4.1.8 Magnetic performance and compass error. The compass shall be placed in a horizontal position on a fixed point and by means of the sighting mechanism, the compass shall be sighted on three targets of known magnetic azimuths approximately 120 degrees apart. With no remedial action by the operator, before, at, or after, a reading shall be taken at each target. The difference between the known azimuths and readings taken is the compass error. An error greater than 40 mils or failure of the compass to function correctly shall constitute failure of this test.

4.4.1.9 Mechanical performance. The following tests shall be with the compass in the operational configuration and away from all magnetic effects external to the compass.

4.4.1.9.1 Damping. The compass magnet shall be deflected 540 ± 20 mils from a position of equilibrium and released. If the magnetic assembly requires more than 6 seconds to come to rest, it shall constitute failure of this test.

4.4.1.9.2 Freedom of rotation when tilted. The compass shall be tilted 8.0 ± 0.1 degree from the horizontal and uniformly rotated 360 degrees at approximately 10 seconds of time per revolution, in a plane normal to the longitudinal axis of the pivot. The compass shall be rotated one complete revolution in the clockwise direction and one complete revolution counterclockwise. Inability of the dial or magnetic assembly to remain free while being rotated shall constitute failure of this test.

4.4.1.9.3 Friction error. The compass dial assembly shall be magnetically deflected 40 ± 5 mils by an external force acting in the horizontal plane of the compass. The mechanism shall be permitted to come to rest. The external force shall then be removed in a radial direction in the same horizontal plane. The compass dial shall then be read. The procedure shall be repeated by deflecting the magnet 40 ± 5 mils in the opposite direction. One-half of the difference between the two readings is the friction error. An error greater than 20 mils shall constitute failure of this test.

4.4.1.9.4 Illumination. The compass shall be examined to verify that the unit has light sources for reading and sighting; the permanent magnet on the dial assembly and the bezel crystal have light sources to aid in setting readings and sighting; and, the "E" (east) and "W" (west) markings are illuminated. Also, verify that the light sources are self-exciting and that all sources are recessed or flush mounted and encapsulated. Failure of this examination constitutes failure of this requirement.

4.4.1.9.4.1 Luminosity. The assembled compass shall be examined visually for dead or dim luminous sources, after it has been dark adapted for not less than 1 hour. The spectral and luminescent output shall be visually compared to a compass used to establish the working standards (see 6.2.1). Sources of questionable luminosity shall be retested. All subsequent brightness tests shall be determined by a photoelectric photometry method, corrected for photopic vision, using a photometer calibrated to the working standards. If the brightness of the luminous sources of the assembled compass is not sufficient to perform all compass functions in

any ambient light and under any of the environmental conditions specified; herein, it shall constitute failure of this test.

4.4.2 Environmental requirements verification.

4.4.2.1 Water leakage. When radiological tests are performed, this test may be accomplished in conjunction with diffusion tests. The complete compass shall be submerged in 300 ml of distilled or deionized water for 24 hours at $23^{\circ}\pm 5^{\circ}\text{C}$. The compass shall be removed from the water and examined for water leakage. If there is evidence of water in the compass bowl at the completion of the test, it shall constitute failure of this test.

4.4.2.2 Shock. The compass, in the open configuration (if applicable), shall be dropped twice from a height of 90 cm onto a solid surface covered with 10 cm of 40 grit kiln dried sand. The sand may be covered with a sheet of plastic not greater than 2 mils thick. The compass shall hit the sand or plastic face up on one drop and edgewise on the second. Any evidence of damage (other than cosmetic) to the compass or failure to operate as specified herein shall constitute failure of this test.

4.4.2.3 Low and high temperature. The completed compass shall be subjected to one complete cycle each of low and high temperature operation. The compass in its closed configuration (if applicable) shall be subjected to a temperature of $-44^{\circ}\pm 2^{\circ}\text{C}$ for a period of 30 minutes without the benefit of solar radiation. After this period and at this temperature, the compass shall be opened (if applicable) and examined. The compass shall then be closed (if applicable) and after stabilizing at room temperature, be subjected to a temperature of $68^{\circ}\pm 3^{\circ}\text{C}$ for a period of 30 minutes. After this period and at this temperature, the compass shall be opened (if applicable) and examined. During either examination, any evidence of damage or failure of the compass dial to seek north and rotate smoothly and freely shall constitute failure of this test.

4.4.2.4 Thermal shock (vials only). Unless certification of conformance is obtained from the luminous source supplier, all radioactive self-luminous source vials to be installed in the compass, shall be subjected to two successive cycles of thermal shock. Begin the cycle by immediately placing the vials in a temperature of $-52^{\circ}\pm 2^{\circ}\text{C}$ for 15 minutes. Remove the vials from the cold environment immediately to a temperature of $68^{\circ}\pm 3^{\circ}\text{C}$ for another 15 minutes. This constitutes one cycle. After the final cycle, the vials shall be returned to room temperature and the sources examined. Any damage or degradation to the vials shall constitute failure of this test.

4.4.3 Support requirements verification.

4.4.3.1 Dimension and weight. The compass shall be measured and weighed. Dimensions greater than 9 cm long, 8 cm wide and 4 cm high, in its closed or stored configuration or weight greater than 170 grams shall constitute failure of this requirement.

4.4.3.2 Radiological containment. If radioactive material is used in the production of compass components, these subordinate tests are mandatory.

4.4.3.2.1 Contamination. A piece of Whatman-50 filter paper, or equivalent, moistened with deionized or distilled water shall be used to wipe the compass. All exterior surfaces of the compass, opened (if applicable), shall be thoroughly wiped with the filter paper. The amount of

MIL-PRF-10436N

radioactive contamination on the filter paper shall be determined using a liquid scintillation counting system capable of measuring 100 picocuries or less of radioactivity. The paper shall be placed in the liquid scintillation solution within one minute of wiping the compass. A removable contamination activity of more than 900 dpm per compass shall constitute failure of this test.

4.4.3.2.2 Diffusion. The completed compass with all the self-luminous sources installed shall be submerged in 300 ml of distilled or deionized water for 24 hours at $23^{\circ} \pm 5^{\circ}\text{C}$. The compass shall be removed from the water and the water shall be analyzed. If the radioactive content of the water exceeds .05 microcuries, it shall constitute failure of the test.

4.4.3.3 Impact durability of vials. Unless otherwise specified (see 6.2), the first article compasses only shall be subjected to this testing procedure. Each compass, in the open configuration (if applicable), shall be subjected to a free fall from a height of 100 cm onto an unyielding, rigid steel surface. The compass shall be dropped twice, without effort to orient the compass or shield the self-luminous sources. Unaided, visual evidence of leakage, breaking, checking, shattering, spalling of the vials shall constitute failure of this test. Damage to the compass, other than the vials, does not constitute failure of this test.

4.4.3.4 Durability. Unless otherwise specified (see 6.2), the first article compasses only shall be subjected to this testing procedure. The compass shall demonstrate a 99% probability of success with a 95% low confidence level with zero failures, each compass shall be tested as follows (recommended minimum number of cycles is 473):

- a. Remove from its case and open the compass completely (if applicable).
- b. The compass in the open configuration, if applicable, shall be dropped from a height of 90 cm, alternately on its face, side and bottom, onto a solid surface covered with 10 cm of 40 grit kiln dried sand. The sand may be covered with a sheet of plastic not greater than 2 mils thick.
- c. After each drop examine the compass for damage.
- d. After each drop rotate the bezel 360° , clockwise on even numbered drops and counter-clockwise on odd numbered drops, to ensure proper operation.
- e. After each drop, alternating targets, sight the compass on one of three targets of known magnetic azimuths approximately 120° apart and record each reading.
- f. After every tenth drop test the compass for friction error as defined in 4.4.1.9.3.
- g. Close the compass (if applicable) and return it to the case.

Any evidence of damage (other than cosmetic) to the compass (or its case) or inability to operate as specified herein shall constitute failure of this test.

4.4.3.5 Finishes.

4.4.3.5.1 Wear surfaces. The compass shall be examined to verify that all exterior surfaces subject to wear are finished in a wear resistant semi-gloss black (see 6.11) finish (e.g. black oxide or anodizing). Failure of this examination constitutes failure of this requirement

4.4.3.5.2 Non-wear surfaces. The compass shall be examined to verify that all external non-wear surfaces have been treated and painted with semi-gloss green enamel (see 6.11). Failure of this examination constitutes failure of this requirement

MIL-PRF-10436N

4.4.3.5.3 Damping shell. The compass shall be examination to verify that inside (visible) surfaces of the damping shell have been treated and painted with semi-gloss white enamel (see 6.11). Failure of this examination constitutes failure of this requirement

4.4.3.6 Markings.

4.4.3.6.1 Identification. The compass shall be examined to verify that the lot identification is permanently marked on the compass, inside the cover (if applicable) and the marking includes year and month of manufacture and lot number, for example 90-7-002. The top of the compass shall be marked with the identification and part number of the manufacturer, and National Stock Number (NSN). Incomplete or illegible marking shall constitute failure of this requirement.

4.4.3.6.2 Radiation marking. If radioactive luminous light sources are used, verify which marking is required (see 6.2).

4.4.3.6.2.1 Specific license marking. The compass shall be examined to verify that the bottom of the compass is permanently marked as required by applicable Nuclear Regulatory Commission Byproduct Materials License; that it includes the radiation caution symbol (not in color), quantity of isotope, the byproduct-materials license number, appropriate control instructions of the using service, and a warning against disassembly. Incomplete or illegible marking shall constitute failure of this requirement.

4.4.3.6.2.2 Marking of a license exempt item. The compass shall be examined to verify that the bottom of the compass is permanently marked to include the Nuclear Regulatory Commission manufacturer's identification number, XXXmCi 3H (where XXX shall be replaced by the actual nominal activity) and CONTROLLED DISPOSAL REQUIRED (see 6.4). Incomplete or illegible marking shall constitute failure of this requirement.

5. PACKAGING

5.1 Packaging. For acquisition purposes, the packaging requirements shall be as specified in the contract or order (see 6.2). When actual packaging of materiel is to be performed by DOD personnel, these personnel need to contact the responsible packaging activity to ascertain requisite packaging requirements. Packaging requirements are maintained by the Inventory Control Point's packaging activity within the Military Department or Defense Agency, or within the System Command of the Military Department. Packaging data retrieval is available from the automated packaging files of the managing Military Department or Defense Agency, CD-ROM products, or by contacting the responsible packaging activity.

6. NOTES

(This section contains information of a general or explanatory nature, which is helpful, but is not mandatory.)

6.1 Intended use. The compass, with self-luminous light sources to facilitate use during periods of darkness, is for obtaining magnetic azimuths for ground navigation, reconnaissance, and fire control purposes.

6.1.1 Military Unique Rationale. The Lensatic Compass is military unique because it must operate satisfactorily and not be damaged during the rigors of worldwide battlefield deployment. The compass is required to survive and perform in extreme cold and heat, not be damaged when

dropped onto hard surfaces, or leak when submerged in water. In addition, the self-excited luminous sources (which have in the past utilized radioactive material) must not be damaged by thermal shock caused by sudden temperature changes of -52°C to 68°C and have a "luminous life" of 12 years, minimum.

6.2 Acquisition requirements. Acquisition documents should specify the following:

- a. Title, number, and date of this specification.
- b. Issue of DODISS to be cited in the solicitation, and if required, the specific issue of individual documents referenced (see 2.2).
- c. When first article inspection is not required (see 3.2).
- d. When compasses for standards are required (see 6.2.1)
- e. Number of additional instruction cards required (see 3.4.7.1).
- f. Whether marking of a compass is to be for specific licenses or for general licenses (see 3.6.6.2.).
- g. When the production lot size is less than 3,200 compasses (see 4.3.1).
- h. When the impact test is not required (see 4.4.3.3).
- i. When the durability test is not required (see 4.4.3.4).
- j. When a manufacturer's certification of service life of luminous sources is required (see 3.4.10.1).
- k. Packaging requirements (see 5.1).
- l. When license to manufacture and distribute radioactive luminous sources is required (see 6.2.2).

6.2.1 Compass standards. When specified (see 6.2), two assembled compasses, of known luminosity, are furnished to the U.S. Army Communications-Electronics Command, Directorate for Safety, ATTN: AMSEL-SF-RE, Building 2539, Laboratory Road, Fort Monmouth, NJ 07703-5024. The Government measures the luminosity of the sources; then, the compasses and readings are returned to the contracting officer. The readings are used as standards in the testing specified in 4.4.1 and 4.4.2. If self-excited luminous sources are used in the production of the compass, the sources will be aged a period of not less than 30 days prior to being assembled into the compass.

6.2.2 Nuclear Regulatory Commission license. If radioactive luminous sources are used, the contractor will obtain a specific license to manufacture and distribute these sources in accordance with the requirements of Title 10 (Nuclear Regulatory Commission) of the Code of Federal Regulations.

6.2.3 Test vials. Prior to production, the source vial provider furnishes the Government with two sets of loose vials (a set of loose vials constitutes the number and specific types of vials installed in a single compass). The Government reserves the right to perform diffusion, contamination, other nondestructive testing and destructive testing, if necessary, on the loose vials. Forward these vials to the U.S. Army Communications-Electronics Command, Directorate for Safety, ATTN: AMSEL-SF-RE, Building 2539, Laboratory Road, Fort Monmouth, NJ 07703-5024.

MIL-PRF-10436N

6.3 First article. When a first article inspection is required, the item(s) should be a pre-production model(s). The first article should consist of ten units. The contracting officer should include specific instructions in acquisition documents regarding arrangements for examinations, approval of the first article test results and disposition of the first articles. Invitation for bids should provide that the Government reserves the right to waive the requirement for samples for first article inspection to those bidders offering a product that has been previously acquired or tested to this specification by the Government, and that bidders offering such products, who wish to rely on such production or test, must furnish evidence with the bid that prior Government approval is appropriate for the pending contract. Bidders should not submit alternative bids unless specifically requested to do so in the solicitation.

6.4 Marking of license exempt item. The contracting officer should take the necessary action to ensure proper marking when a license exempt item is being furnished (see 3.6.6.2.2).

6.5 Definitions. The following definitions apply for this specification.

6.5.1 Compass durability. The compass will have a 99% probability of success with a 95% low confidence level during a 12-year life.

6.5.2 Historical samples. Five compasses are randomly selected from the first two hundred production compasses from the first lot and forwarded to the U.S. Army Communications-Electronics Command, Directorate for Safety, ATTN: AMSEL-SF-RE, Building 2539, Laboratory Road, Fort Monmouth, NJ 07703-5024. The Government retains these compasses for comparative purposes and to establish a historical audit trail.

6.6 Subject term (key word) listing.

Magnetic

Lensatic

Graduated

Induction damped

Self-luminous

6.7 Changes from previous issue. Marginal notations are not used in this revision to identify changes with respect to the previous issue due to the extensiveness of the changes.

6.8 Comparison inspection.

6.8.1 Government verification testing. The Government performs verification testing of production compasses as follows:

Five compasses will be randomly selected from each production lot of 3,200 compasses for removable contamination, water leakage, and luminosity testing. These five compasses cannot be from previously selected samples, but are chosen from the remaining compasses of the lot. There are no substitutions. The contractor performs a contamination wipe test on these five compasses. These compasses are not washed or cleaned, in any way, following the test. The compasses and wipes are forwarded to the U.S. Army Communications-Electronics Command, Directorate for Safety, ATTN: AMSEL-SF-RE, Building 2539, Laboratory Road, Fort Monmouth, NJ 07703-5024 for liquid scintillation

MIL-PRF-10436N

counting. Upon completion of tests, the Directorate for Safety will notify the contracting officer of the results within 7 working days. Failure of any of the five compasses constitutes failure of this test.

6.8.1.1 Random testing. The Government may select compasses at any time during the contract production period and subject these compasses to verification of the requirements in section 3, the examination specified in section 4 as specified in table II (see 4.2.2), to determine conformance to the requirements of this specification. The inspection will be performed by the Government, at a site selected by the Government, on units selected at random from those that have been accepted by the Government and will not include the previously inspected first article model compasses. In addition to any test specified as part of the inspection comparison, the Government reserves the right to conduct any and all other tests contained in this specification as part of the inspection comparison, and failure of such additional tests will have the same effect as failure of these tests specified as conformance inspection.

6.9 Sample size. The contracting officer should include specific instructions in acquisition documents regarding the sample size. In the past, a sample size of 125 compasses for a lot size of 3,200 compasses was required.

6.10 National Stock Numbers (NSN): The following NSNs have been used to procure this item: 6605-01-196-6971, 6605-00-151-5337, 6605-00-283-034, 6605-00-846-7618, and 6605-00-664-4652.

6.11 Colors: The following colors and color codes from Federal Standard No. 595 have been used for this specification:

Color	Code
Black (semi-gloss)	27038
Black (lusterless)	37038
White (semi-gloss)	27875
Green (semi-gloss)	24097
Green (lusterless)	34097
Red (semi-gloss)	21105

MIL-PRF-10436N

REF ONLY

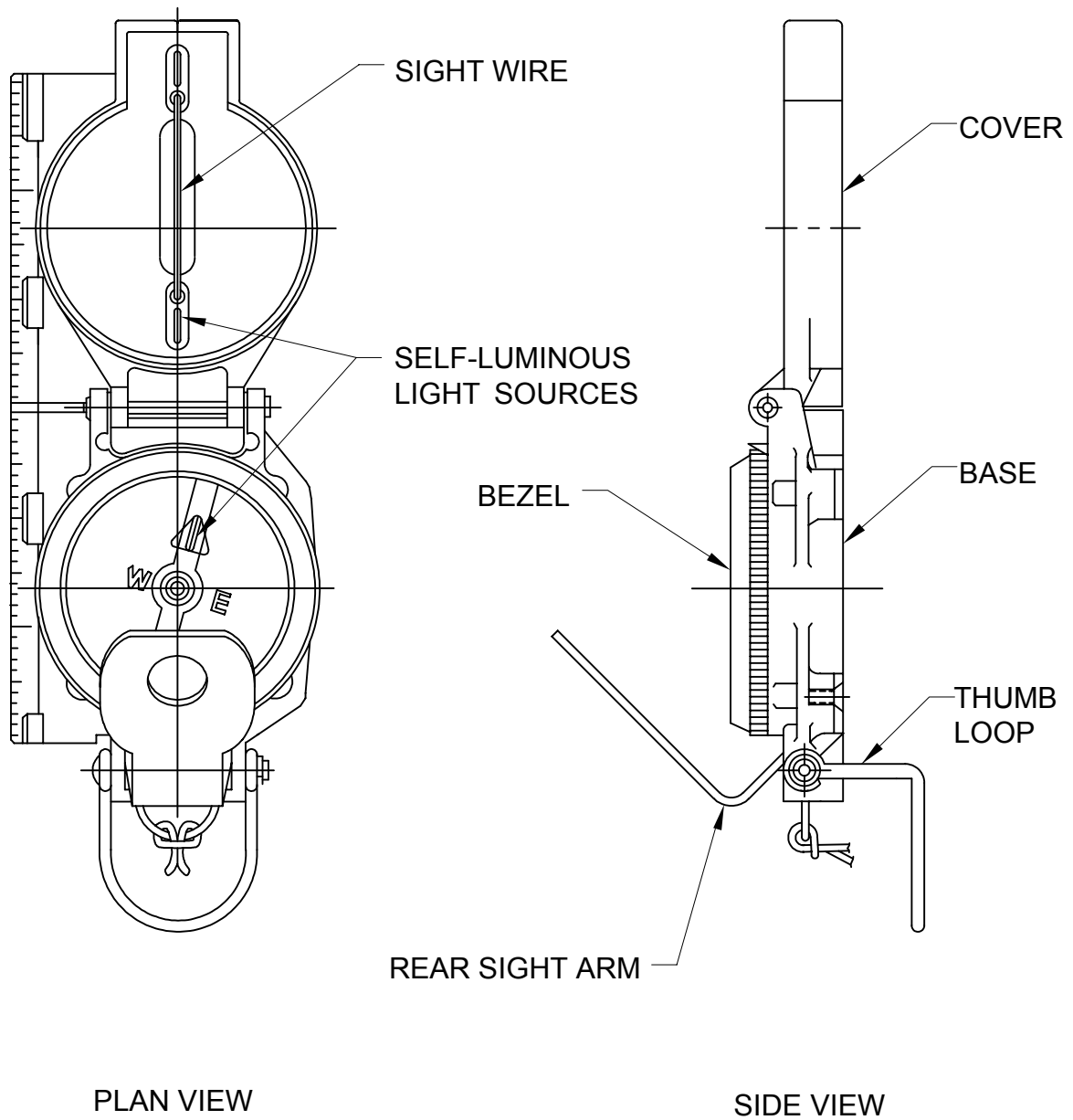

COMPASS - OPEN

FIGURE 1A. Lensatic compass.

MIL-PRF-10436N

REF ONLY

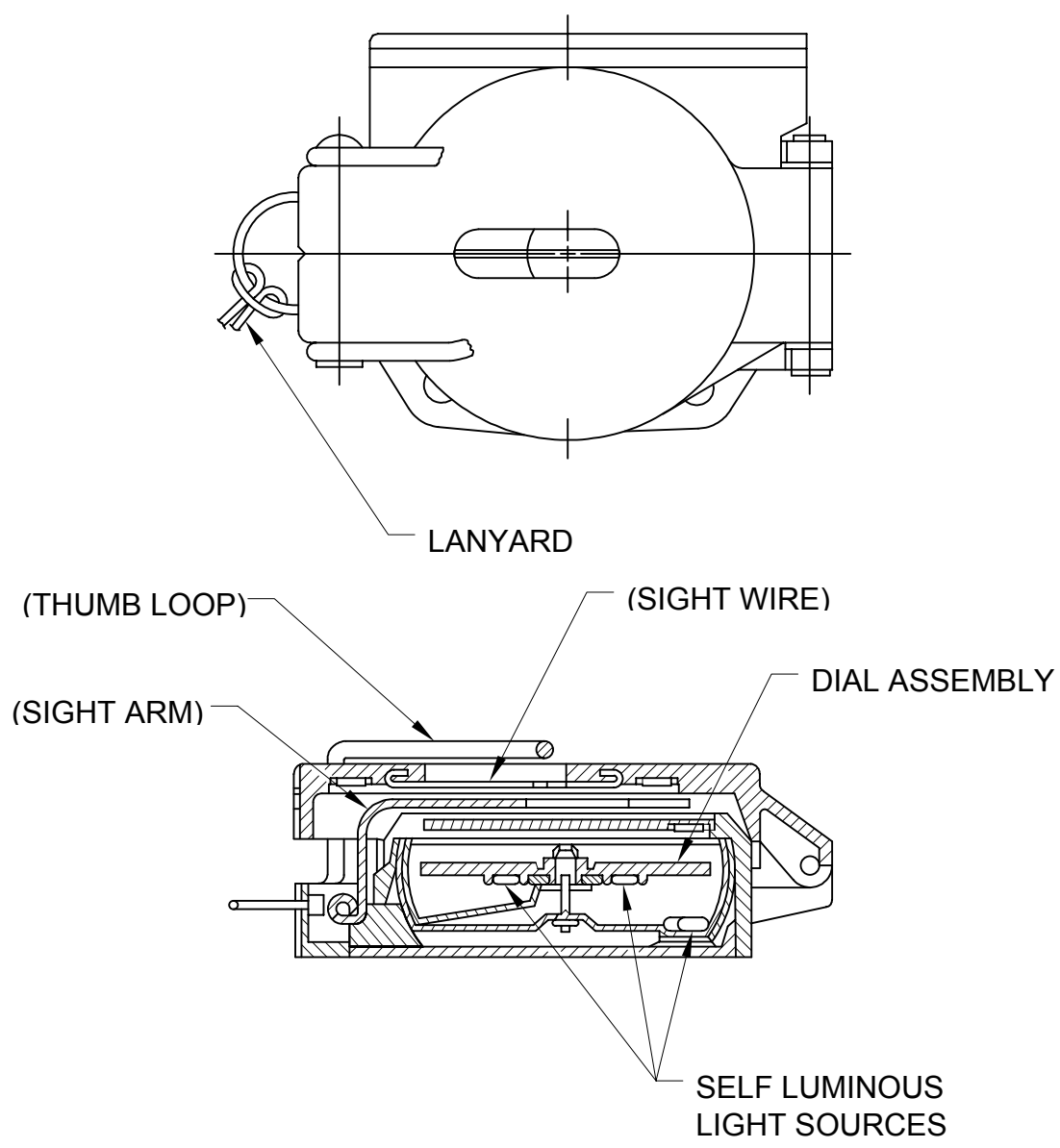

COMPASS - CLOSED

FIGURE 1B. Lensatic compass.

MIL-PRF-10436N

Custodians:

Army - CE3
Air Force – 99
Navy - MC

Preparing activity:

Army - CE3

(Project 6605-0522)

Review Activity:

Army - CR
Navy - SH
DLA - GS

Civilian Coordinating Activity:

GSA-FSS