

**MIL-HDBK-258(AS)**

3 August 1979

**MILITARY HANDBOOK**

**INTERFACE CONTROL DOCUMENT**

**FOR**

**INFRARED DETECTING SET**

**AN/AAS-36**



**FSC 5855**

MIL-HDBK-258(AS)

DEPARTMENT OF DEFENSE  
WASHINGTON, D C 20360

MIL-HDBK-258(AS)

Interface Control Document for Infrared Detecting Set AN/AAS-36

1. This interface control handbook was developed by the Department of Defense with the assistance of the Naval Air Systems Command in accordance with established procedure.
2. This document was approved on \_\_\_\_\_ for printing and inclusion in the military interface control handbook series.
3. This document provides basic and fundamental information on the physical and functional interface requirements for aircraft installation of the AN/AAS-36 Infrared Detecting Set. The defined interfaces establish the compatibility between cofunctioning elements and control the interface design. This handbook is intended to be referenced in purchase specifications for applicable equipment.
4. Every effort has been made to reflect the latest information on installation interface requirements for the AN/AAS-36 Infrared Detecting Set. It is the intent to review this handbook periodically to insure its completeness and currency. Beneficial comments (recommendations, additions, deletions) and any pertinent data which may be of use in improving this document, should be addressed to: Commanding Officer, Naval Air Engineering Center, Engineering Specifications and Standards Department (ESSD) Code 93, Lakehurst, NJ 08733, by using the self-addressed Standardization Document Improvement Proposal (DD Form 1426) appearing at the end of this document or by letter.

CONTENTS

		<u>Page</u>
Paragraph 1.	SCOPE - - - - -	1
1.1	Scope - - - - -	1
1.2	Purpose - - - - -	1
1.3	General conditions and responsibilities- - -	1
1.3.1	Associated equipment- - - - -	1
2.	REFERENCED DOCUMENTS - - - - -	2
2.1	Issues of documents-----	2
2.2	Non-Government documents- - - - -	3
3.	DEFINITIONS - - - - -	5
3.1	Symbols, abbreviations and acronyms - - - -	5
4.	GENERAL STATEMENT OF REQUIREMENTS- - - - -	6
4.1	Functional description- - - - -	6
4.1.1	Receiver converter-----	6
4.1.2	Power supply/video converter- - - - -	7
4.1.3	Control, servomechanism - - - - -	7
4.1.4	Control, detecting set, infrared- - - - -	7
4.1.5	Control, sight, target tracking - - - - -	7
4.1.6	Indicator, video-----	8
4.2	Overall characteristics - - - - -	8
4.3	Aircraft installation - - - - -	8
4.3.1	Receiver converter- - - - -	8
4.3.1.1	Location of unit-----	8
4.3.1.2	Limits to normal operation attitude - - - -	8
4.3.1.3	Precautions-----	9
4.3.1.4	Mounting instructions - - - - -	9
4.3.2	Power supply-video converter- - - - -	9
4.3.2.1	Location of unit-----	9
4.3.2.2	Limits to normal operation attitude - - - -	9
4.3.2.3	Precautions-----	10
4.3.2.4	Mounting instructions - - - - -	10
4.3.3	Control-servomechanism- - - - -	10
4.3.3.1	Location of unit-----	10
4.3.3.2	Limits to normal operation attitude - - - -	10
4.3.3.3	Precautions- - - - -	10
4.3.3.4	Mounting instructions - - - - -	11
4.3.4	Control, detecting set, infrared- - - - -	11
4.3.4.1	Location of unit-----	11
4.3.4.2	Limits to normal operation attitude - - - -	11
4.3.4.3	Precautions-----	11
4.3.4.4	Mounting instructions - - - - -	11

MIL-HDBK-258(AS)

CONTENTS - Continued

		<u>Page</u>
Paragraph 4.3.4.5	Environmental limits- - - - -	11
4.3.5	Control, sight, target tracking - - - - -	11
4.3.5.1	Location of unit-----	11
4.3.5.2	Limits to normal operation attitude - - - -	12
4.3.5.3	Precautions - - - - -	12
4.3.5.4	Mounting instructions - - - - -	12
4.3.5.5	Environmental limits- - - - -	12
4.3.6	Indicator, video- - - - -	12
4.3.6.1	Location of unit-----	12
4.3.6.2	Limits to normal operation attitude - - - -	12
4.3.6.3	Precautions - - - - -	12
4.3.6.4	Mounting instructions - - - - -	13
4.3.6.5	Environmental limits- - - - -	13
5.	DETAILED STATEMENT OF REQUIREMENTS - - - - -	14
501	AN/AAS-36 (IRDS)/aircraft interfaces- - - -	14
5.1.1	Mechanical - - - - -	14
5.1.1.1	WRA (outline dimension drawings)- - - - -	14
5.1.2	Aircraft installation retractable turret ( typical ) - - - - -	14
5.1.3	Aircraft installation fixed turret ( typical ) - - - - -	14
5.1.4	Thermal characteristic requirements - - - -	14
5.1.5	Receiver converter aircraft alignment accuracy requirement - - - - -	14
5.1.6	Receiver-converter assembly - mechanical alignment check - retractable turret - - -	15
5.1.7	Receiver-converter assembly - mechanical alignment check - fixed turret - - - - -	15
5.2	Electrical - - - - -	15
5.2.1	Aircraft power - - - - -	15
5.2.1.1	Aircraft power characteristics- - - - -	15
5.2.2	Equipment power requirements- - - - -	16
5.2.2.1	AN/AAS-36 input power - - - - -	16
5.2.2.2	AN/AAS-36 input power requirements- - - -	16
5.2.2.3	IRDS/aircraft electrical system interface -	17
5.2.2.3.1	IRDS aircraft electrical system interface -	17
5.2.2.3.2	IRDS/lamp test power source interface - - -	17
5.2.3	Interconnection diagrams- - - - -	17
5.2.4	Cabling details -----	17
5.2.5	Ground/bonding- - - - -	17
5.2.5.1	Aircraft interconnecting cables - - - - -	18
5.2.6	Video characteristics - - - - -	18

CONTENTS - Continued

	<u>Page</u>
Paragraph 5.3	AN/AAS-36 data system interfaces- - - - - 18
5.3.1	AN/AAS-36/data processing system interface ( P - 3 C ) - - - - - 18
5.3.1.1	Data update timing requirements - - - - - 19
5.3.1.2	Data bit identification - - - - - 20
5.3.2	AN/AAS-36/data processing interface - - - - 20
5.3.2.1	IRDS status logic signals - - - - - 20
5.3.3	AN/AAS-36 synchro data interface- - - - - 21
5.3.3.1	Synchro excitation reference- - - - - 21
5.3.3.2	Electrical zero - - - - - 21
5.4	AN/AAS-36 electrical interlocks - - - - - 22
5.4.1	AN/AAS-36/maintenance switch- - - - - 22

MIL-HDBK-258 (AS)

FIGURES

			<u>Page</u>
Figure 1		Receiver converter, outline drawing- - - - -	62
2		Power supply/video converter, outline drawing - - - - -	67
3		Control servomechanism, outline drawing- - -	69
4		Control, detecting set, infrared, outline drawing - - - - -	71
5		Control, sight, target tracking, outline drawing - - - - -	72
6		Indicator, video, outline drawing- - - - -	73
7		Receiver converter retractable turret installation (typical)- - - - -	77
8		Receiver converter fixed turret installation (typical) - - - - -	78
9		IRDS aircraft primary power interface- - - -	80
10		IRDS interconnecting block diagram - - - - -	81
11		Typical IRDS/data processing system interfaces (P-3C) - - - - -	82
12		DOW/IRDS interface timing diagram (P-3C) - -	83
13		LU-1 DOM/IRDS control servomechanism interface (P-3C)- - - - -	84
14		Data bit 11 signal characteristics - - - - -	85
15		Data bit 00 signal characteristics - - - - -	86
16		Output acknowledge signal characteristics- -	87
17		DOM/IRDS data update timing requirements - -	88
18		IRDS/data processing system status logic interface (P-3C)- - - - -	89
19		Computer track signal characteristics- - - -	90
20		Manual track override signal characteristics	91
21		IRDS az position signal characteristics- - -	92
22		IRDS el position signal characteristics- - -	93
23		26 VAC reference voltage signal characteristics - - - - -	94
24		IRDS/signal data converter interwiring details - - - - -	95
25		Maintenance switch/IRDS interface- - - - -	96
26		IRDS interconnecting diagram - - - - -	97

TABLES

			Page
Table	I	IRDS input power requirements (maximum steady state) -----	17
	II	IRDS interwiring listing - - - - -	23
	III	Angle rate codes-----	60
	IV	Metric equivalents inches to millimeters - -	79



## 1. SCOPE

1.1 Scope. This handbook establishes the physical and functional interface for aircraft installation of the AN/AAS-36 infrared detecting set (IRDS). The physical and electrical interfaces are defined for the IRDS supplier, the airframe contractor and the operational program.

1.2 Purpose. The defined interfaces establish the compatibility between cofunctioning elements and control the interface design. Any changes in these areas may affect the installation compatibility or operation. Contemplated changes affecting any of the defined area must be coordinated with all custodial and review activities.

1.3 General conditions responsibilities. The AN/AAS-36 IRDS was designed and is fabricated by Texas Instruments. Intended airborne installation of the IRDS is for either retractable or fixed turret applications for such aircraft as P-3B, P-3C, S-3A, etc. Target tracking by the IRDS is either manual or computer controlled, via on-board data processing systems, when applicable. Lockheed Aircraft Company designed and fabricates a turret retraction mechanism for P-3C IRDS installations. NADC developed the necessary software programs to control IRDS tracking for this configuration.

1.3.1 Associated equipment. The AN/AAS-36 interfaces with data processing systems such as the AN/AYA-8 [MIL-D-81347C(AS)] and AN/ASQ-114(V) [MIL-C-81332B(AS)], a synchro to digital converter such as the CV-2461 A/A [MIL-C-81344(AS)], aircraft power and lighting supplies and aircraft maintenance control devices.

MIL-HDBK-258(AS)

## 2. REFERENCED DOCUMENTS

2.1 Issues of documents. The following documents of the exact issue indicated, form a part of this handbook to the extent specified herein.

### SPECIFICATIONS

#### MILITARY

- |                                   |   |
|-----------------------------------|---|
| MIL-C-172C                        | - Cases, Bases, Mounting;<br>Mounts, Vibration.                                   |
| MIL-C-81332B(AS)<br>1 May 1967    | - Military Specification<br>for Computer, Digital<br>AN/ASQ-114(V).               |
| MIL-C-81344(AS)<br>1 May 1968     | - Military Specification<br>for Signal Data Con-<br>verter CV-2461A/A.            |
| MIL-D-81347C(AS)<br>13 March 1974 | - Military Specification<br>for Data Analysis Pro-<br>gramming Group<br>AN/AYA-8. |

#### NAVAL AIR SYSTEMS COMMAND

- |                                  |   |
|----------------------------------|---|
| MIL-I-85295(AS)<br>15 April 1979 | - Military Specification<br>- Detecting Set, Infra-<br>red AN/AAS-36. |
|----------------------------------|---|

#### BUREAU OF NAVAL WEAPONS

- |                                       |   |
|---------------------------------------|---|
| WR-101, Part I<br>dated (15 Feb 1968) | - Electromagnetic Control<br>Requirements for Ad-<br>vanced ASW Avionics<br>System. |
|---------------------------------------|---|

STANDARDS

MILITARY

- |                                   |   |
|-----------------------------------|---|
| MIL-STD-704A<br>9 August 1966     | - Military Standard -<br>Electric Power, Air-<br>craft, Characteristics<br>and Utilization.       |
| MIL-STD-1472B<br>31 December 1974 | - Human Engineering De-<br>sign Criteria for<br>Military Systems Engi-<br>neering and Facilities. |

DRAWINGS

MILITARY

- |         |   |
|---------|---|
| MS25213 | - Control Panel, Aircraft<br>Equipment, Typical<br>Installations. |
|---------|---|

(Copies of specifications, standards, drawings and publications re-  
quired by contractors in connection with specific procurement functions  
should be obtained from the procuring activity or as directed by the  
contracting officer.)

2.2 Non-Government publications. The following documents of the  
exact issue date indicated, form a part of this handbook to the extent  
specified herein.

ELECTRONIC INDUSTRIES ASSOCIATES

- |                                |  |
|--------------------------------|--|
| EIA-RS-343-A<br>September 1969 | - Electrical Performance<br>Standard for High Reso-<br>lution Monochrome<br>Closed Circuit Televi-<br>sion Camera. |
|--------------------------------|--|

GENERAL ELECTRIC COMPANY

- |              |  |
|--------------|--|
| G.E. 7528383 | - Device Specification -<br>Line Receiver. |
| G.E. 7528376 | - Device Specification -<br>Line Driver.   |

MIL-HDBK-258(AS)

TEXAS INSTRUMENTS

T.I. 536993

Device Specification -  
Line Receiver (Equiva-  
lent to National -  
DM7820).

T.I. 536996-1

Device Specification -  
Line Driver (Equivalent  
to National DM7830).

Application for copies of non-government documents should be  
addressed to the Naval Air Systems Command, Washington, D C 20360,  
Attn: AIR-549332.

### 3. DEFINITIONS

3.1 Symbols, abbreviations and acronyms. Symbols, abbreviations and acronyms applicable to this handbook are defined as follows:

AC	Alternating Current
A/C	Aircraft
AZ	Azimuth
DC	Direct Current
DIM	Digital Input Multiplexer
DOM	Digital Output Multiplexer
DPS	Data Processing system
EL	Elevation
FT	Feet
FRP	Fuselage Reference Plane
GA	Gauge
GE	General Electric Company
GFE	Government Furnished Equipment
GND/GRD	Ground
Hz	Hertz
ICD	Interface Control Document
IRDS	Infrared Detecting Set
LCC	Lockheed-California Company
LED	Light Emitting Diode
LOS	Line of Sight
LSB	Least Significant Bit
LU-1	Logic Unit No. 1
MA	Milliamperes
MAX	Maximum
MHz	Megahertz
MIN	Minimum
MSB	Most Significant Bit
MSEC	Milliseconds
NOM	Nominal
OA	Output Acknowledge
Sec	Second
S/D	Synchro to Digital
SDC	Signal Data Converter
SS-3	Sensor Station 3
TBD	To Be Determined
TBS	To Be Supplied
TTSC	Target Tracking Sight Control
TV	Television
UF	Microfarads
USEC	Microseconds
VA	Volt Amperes
VRMS	Volts, Root Mean Square
WRA	Weapon Replaceable Assembly
0	Phase

MIL-HDBK-258(AS)

#### 4. GENERAL STATEMENT OF REQUIREMENTS

4.1 Functional description. Infrared Detecting Set AN/AAS-36 is a modularized IR sensor system composed of the following six WRA's:

Receiver Converter, Infrared	R-2005/AAS-36
Power Supply/Video Converter	PP-7267/AAS-36
Control Servomechanism	C-9982/AAS-36
Control, Detecting Set, IR	C-9983/AAS-36
Control, Sight, Target Tracking	C-9984/AAS-36
Indicator Video	IP-1240/AAS-36

The receiver converter is installed in a fixed or retractable turret, preferably on the underside of the aircraft fuselage. Sensor operation is controlled by on-board operators by means of the control, sight, target tracking (hand control) in manual mode and by data processing system interfaces in computer track mode. In the computer track mode, the data processing system accepts IRDS gimbal position data, computes the angular difference between the LOS to the target and the platform boresight reference axis and provides azimuth and elevation rate commands to reposition the gimbals.

4.1.1 Receiver converter. The receiver converter contains the IR sensing unit mounted on a two-axis gimbal system. The outer turret housing rotates  $\pm 200^\circ$  from the FRP(YZ) of the aircraft with the azimuth gimbal. The elevation gimbals are not subjected to airloads, operating completely inside the turret housing within +16 and -820 limits referenced to the FRP(YZ).

The sensor has a two-position lens system providing two fields of view, 250 (diagonal) and approximately 80 (diagonal), selectable by the operator. Cooling for the detector elements is provided by a self-contained closed-cycle, cryogenic cooler. The individual IR image channels are amplified and operate a companion LED channel. These elements are converted to standard EIA imagery by mirror-sweeping these channels over a vidicon tube. Standard TV signal processing provides the image on the TV display.

The receiver converter is designed to operate satisfactorily over an ambient temperature range of  $-54^\circ\text{C}$  to  $+55^\circ\text{C}$ . At ambient temperatures below  $+20^\circ\text{C}$ , the unit maintains an internal temperature of approximately  $+25^\circ\text{C}$  by automatically-controlled heater elements. At ambient temperatures above  $+25^\circ\text{C}$  and up to a maximum steady state temperature of  $+55^\circ\text{C}$ , the receiver converter utilizes external ambient air and an air to air heat exchanger to maintain proper internal receiver-converter operating temperatures.

Because the receiver converter weight exceeds the lift capability of one or even two men as defined in MIL-STD-1472B, this WRA is provided with lift points for removal/replacement in the aircraft.

4.1.2 Power supply/video converter. This unit provides the interface between the aircraft 28 VDC and 115/200 V 400 Hz aircraft power sources and the IRDS system. The power supply provides  $\pm 14$  and  $\pm 15$  VDC for the sensor focus;  $\pm 5$ ,  $\pm 8$ ,  $\pm 10$ ,  $\pm 15$  VDC for sensor preamp, post amps and scanner circuits;  $\pm 5$ ,  $\pm 8.5$ ,  $\pm 40$  VDC for TV circuits; and  $\pm 15$  VDC for the gimbal angle indicator circuitry. Video signals from the receiver converter are combined with gimbal angle signals for presentation on the video indicator. The grey scale generator for setting video indicator controls is also located in this unit.

4.1.3 Control servomechanism. The unit accepts data processing system generated rate signals or target tracking position inputs to generate proper azimuth and elevation rate drive signals to position the receiver converter. Receiver-converter azimuth and elevation position feedback to the data processing system is provided for position compensation. Four power supplies provide  $\pm 30$ ,  $\pm 15$ , and  $\pm 5$  VDC for servo and turret drive functions.

4.1.4 Control, detecting set, infrared. This unit provides all IRDS control functions except for video indicator controls and the sight control. All power to the AN/AAS-36 is controlled by the mode selector. A grey scale control switch is provided. Manual elevation and azimuth position controls permit selective positioning of the receiver-converter LOS with the mode selector in POS. Six status indicators and a bit control on demand only provide system status. A RTCL BRT (reticle brightness), LEVEL, and GAIN pots provide operator control of these functions. A focus control provides four, manual selectable focus options to the operator. FOV (field of view) and POL (polarity) switches permit operator selection of narrow or wide field of view and white or black hot images.

When the mode select is in CPTR TRK position, the IRDS will accept data processing system generated rate commands. Depressing the trigger switch on the sight control permits operator override of computer track but the target position to the computer is continuously available. In the MAN mode, receiver-converter LOS is directed by operation of the sight control.

4.1.5 Control, sight, target tracking. This unit provides for manual control of the receiver converter when the mode is set to MAN, and permits override of CPTR TRK. Overriding CPTR TRK, by depressing the trigger switch, disconnects data processing system control. The new turret position(s) directed by the operator are transferred to the data processing system when the switch is released.

MIL-HDBK-258(AS)

Receiver-converter manual positioning is controlled by a thumb ball on top of the control - fore/aft motion causes correlated motion of LOS in elevation, left/right pressure causes the receiver LOS to move counterclockwise/clockwise proportionally to the applied pressure.

4.1.6 Indicator, video. This unit, a 9" display, provides the video image to the operator. Gimbal angle indicators located on the left side and top of the unit provide direct readout of the receiver-converter LOS relative to the aircraft. The unit provides a 32:1 contrast ratio with a capability of displaying ten grey shades.

This unit requires 115 V 400 Hz aircraft power, and is a self-contained unit. Power to the unit is controlled by the IRDS control. Brightness and contrast controls are operator adjustable. A power on/off switch is also provided. Impedance switching between hi and 75 ohms is provided on the rear as are two triax video connectors.

4.2 Overall characteristics. The operational requirements of the IRDS as well as the sensitive infrared receiver performance characteristics such as spectral bandpass, square wave response, minimum resolvable temperature and noise equivalent temperature differential are classified (Confidential) and may be obtained from corresponding paragraph references in AS-3900A.

4.3 Aircraft installation. The following provides installation limitations and precautions for the six IRDS weapons replaceable assemblies.

#### 4.3.1 Receiver converter.

4.3.1.1 Location of the unit. This unit contains the gimballed receiver. Its aperture must be mounted so that energy can be received from at least the lower hemisphere under the aircraft. The outline dimension drawing (see figure 1) defines the aperture location with respect to the mounting structure and shows gimbal angle coverage. The lower forward portion of the aircraft fuselage is a preferred location.

Buffeting that could be caused by propellers or skin discontinuities should be avoided.

Damage to the optical window that could be caused by debris from the landing gear or by leaks from a hydraulic system should be avoided.

4.3.1.2 Limits to normal operation attitude. The forward direction is shown on the outline dimension drawing. The unit should be mounted parallel to aircraft FRP to provide correct gimbal angle readouts and prevent tilting of the displayed infrared image. Receiver-converter alignment requirements are defined in paragraph 5.1.5.

#### 4.3.1.3 Precautions.

- a. Avoid sharp bends in all cables
- b. Maximum length of cables to the receiver converter is 40 feet
- c. Provide access at top for connectors
- d. Avoid excessive loading by the mounting structure that could cause gimbal binding
- e. Maintain air space and circulation around upper shroud to maintain cooling
- f. Provide overhead access for hoisting into place (see figure 1 for hoisting eye location)
- g. Provide access for boresight pins
  - 10 Azimuth pin shown on outline dimension drawing
  2. Elevation pin access is attained by removal of the 20-inch diameter turret
- h. Provide proper grounding of unit for personnel safety
- i. Provide access to elapsed time meter when in stowed position
- j. Provide access for turret window cleaning

4.3.1.4 Mounting instructions. A rigid mounting structure is required that securely restrains the unit at the four perimeter locations.

#### 4.3.2 Powe supply - video converter.

4.3.2.1 Location of unit. The Power Supply - Video Converter, PP-7267/AAS-36 will be located in a conventional equipment mounting area as near as possible to the other interconnected WRA'S to minimize cable lengths.

<sup>4</sup>.3.2.2 Limits to normal operation attitude. The Power Supply - Video Converter, PP-7267/AAS-36 may be operated in any attitude. For easiest maintenance, it should be approximately level.

MIL-HDBK-258(AS)

4.3.2.3 Precautions.

- a. Avoid sharp bends in all cables
- b. Provide access in front of unit for electrical connectors and elapsed time meter
- c. Provide proper grounding for personnel safety
- d. Provide air space and circulation around filters in front and the fan outlet in the rear of unit
- e. Avoid excessive loading in mounting that could damage case
- f. Provide clearance for drainhole in bottom of unit
- g. Provide access for filter cleaning maintenance

4.3.2.4 Mounting instructions. The power supply-video converter is designed for use on a mounting base such as prescribed in MIL-C-172C except for non-standard size and fastener spacing.

4.3.3 Control-servomechanisms.

4.3.3.1 Location of unit. The Control-Servomechanism, C-9982/AAS-36 will be located in a conventional equipment mounting area as near as possible to the other interconnected WRA's to minimize cable lengths.

4.3.3.2 Limits to normal operation attitude. The Control-Servo-mechanism C-9982/AAS-36 may be operated in any attitude. For easiest maintenance, it should be approximately level.

4.3.3.3 Precautions.

- a. Avoid sharp bends in all cables
- b. Provide access in front of unit for electrical connectors and elapsed time meter
- c. Provide proper grounding for personnel safety
- d. Provide air space and circulation around filters in front and the fan outlet in the rear of unit
- e. Avoid excessive loading in mounting that could damage case

- f. Provide clearance for drainhole in bottom of unit
- g. Provide access for filter cleaning maintenance

4.3.3.4 Mounting instructions. The Control-Servomechanism C-9982/AAS-36 is designed for use on a mounting base such as described in MIL-C-172C except for non-standard size and fastener spacing.

4.3.4.1 Location of unit. Control, Detecting Set, Infrared, C-9983/AAS-36 shall be mounted in the IRDS AN/AAs-36 operator's station as near as possible to interconnecting units to minimize cable lengths (40 foot maximum cable length). The unit should be located for easy access to controls in flight. Unit is to be operated in conjunction with the Control, Sight, Target Tracking, C-9984/AAS-36 and the Indicator, Video, IP-1240/AAS-36.

4.3.4.2 Limits to operation attitude. Control, Detecting Set, Infrared, C-9983/AAS-36 may be mounted in any attitude that meets paragraph 4.3.4.1 requirements.

4.3.4.3 Precautions.

- a. Avoid sharp bends in all cables
- b. Provide service length in cables for unit installation and removal
- co Provide proper grounding for operator's safety

4.3.4.4 Mounting Instructions. Control, Detecting Set, Infrared, C-9983/AAS-36 shall be mounted as described in MS25213.

4.3.4.5 Environmental limits. The Control, Detecting Set, Infrared, C-9983/AAS-36 is limited to 15,000 feet altitude operation (may be operated at higher altitudes in a pressurized area).

4.3.5 Control, sight. target tracking.

4.3.5.1 Location of unit. Control, Sight, Target Tracking C-9984/AAS-36 will be located in the IRDS operator's station as near as possible to interconnecting units in order to minimize cable lengths (40 foot maximum cable length). The unit should be located for ease of operation. The unit is operated in conjunction with the Control, Detecting Set, Infrared, C-9983/AAS-36 and the Indicator, Video IP-1240/AAS-36.

MIL-HDBK-258(AS)

4.3.5.2 Limits to normal operation attitude. Control, Sight, Target Tracking C-9984/AAS-36 may be mounted in any attitude for operator convenience.

4.3.5.3 Precautions.

- a. Avoid sharp bends in cable
- b. Provide service length in cable for unit installation and removal
- c. Provide proper grounding for operator's safety

4.3.5.4 Mounting instructions. The Control, Sight, Target Tracking C-9984/AAS-36 shall be mounted similar to the method described in MS25213 except spacing of fasteners is not standard.

4.3.5.5 Environmental limits. The Control, Sight, Target Tracking C-9984/AAS-36 is limited to 15,000 feet ambient altitude operation (may be operated at higher altitudes in a pressurized area).

4.3.6 Indicator, video.

4.3.6.1 Location of unit. The Indicator, Video IP-1240/AAS-36 will be located in the IRDS operator's station, as near as possible to inter-connecting units, "to minimize cable lengths (maximum cable length is 40 feet). The indicator should be located for easy access to operator controls and should be positioned for comfortable viewing (18 to 24 inches from operator's eyes). The indicator is operated in conjunction with the Control Detecting Set, Infrared, C-9983/AAS-36 and the Control, Sight, Target Tracking, C-9984/AAS-36.

4.3.6.2 Limits to normal operation attitudes. The Indicators, Video IP-1240/AAS-36 may be mounted in any attitude for operator convenience.

4.3.6.3 Precautions.

- a. Avoid sharp bends in all cables
- b. Provide proper grounding for operator's safety
- c. Provide air space and circulation around bottom intake filters and fan outlet in rear of unit
- d. Provide access to air filter in bottom of unit for maintenance

- e. Mount in an area of low illumination and protect screen from glare and reflected light

4.3.6.4 Mounting instructions. The Indicator, Video IP-1240/AAS-36 shall be mounted by the 4 holes in the bottom. The 0.19 inch clearance provided by the mounting pads shall not be obstructed to insure adequate cooling air inlet. Leave space for removal of air filters.

4.3.6.5 Environmental limits. The Indicator, Video IP-1240/AAS-36 is limited to 15,000 feet altitude operation (may be operated at higher altitudes in a pressurized area).

MIL-HDBK-258(AS)

## 5. DETAILED STATEMENT OF REQUIREMENTS

5.1 AN/AAS-36 (IRDS)/aircraft interfaces. The infrared detecting set consists of six weapon replaceable assemblies requiring electrical interconnection with each other and with other aircraft systems. Mechanical interface details including WRA outline dimension drawings, aircraft location and installation requirements, thermal characteristics etc. are presented in paragraph 5.1. Electrical interface details including input power requirements, cable division and aircraft subsystem interface interconnection, connector types, detail pin and wire assignments, grounding, shielding, interface timing, etc. are presented in paragraphs 5.2 and 5.3.

Every consideration shall be given in location of equipment and in design of installation details to promote operator efficiency and maintenance facility.

### 5.1.1 Mechanical.

5.1.1.1 WRA(outline dimension drawings). Outline dimension drawings for the IRDS WRA's are provided in figures 1 through 6. The outline drawings include weight, center of gravity, maximum heat dissipation and special installing instructions/notes, in addition to the dimensional information for each WRA.

5.1.2 Aircraft installation [retractable turret (typical)]. The location and mechanical interface for the IRDS receiver converter is shown in figure 7 for a typical (P-3C) retractable turret installation.

5.1.3 Aircraft installation fixed turret (typical) The location and mechanical interface for the IRDS receiver converter is shown in figure 8 for typical fixed turret installations.

5.1.4 Thermal character/requirements. The heat dissipation, air inlet and air outlet sizes and locations for each IRDS unit are given in outline figures 1 through 6. Minimum distance from an obstruction to an air outlet opening is also indicated in the outline figures.

5.1.5 Receiver converter aircraft alignment accuracy requirements. In the computer track mode, the data processing system, utilizing sensed target location (relative to the aircraft), will provide IRDS LOS pointing (rate) commands. The computer will utilize target azimuth, target range and aircraft altitude to continuously predict IRDS elevation and azimuth angles to intercept the designated target. These angles will utilize the fuselage reference planes (FRP) as the origin. Proper rate (az and el) commands will be generated and provided to the IRDS to position the LOS on the target. A designated

target will fall within the narrow FOV under computer control when all external system errors are limited to 2.4 degrees elevation and 3.2 degrees azimuth (3 sigma values) and the stabilized turret platform is aligned to the FRP within 0.50 degree.

Note: Any relaxation of this installation requirement will result in a decrease in the allowable system error to provide the same acquisition probability.

5.1.6 Receiver-converter assembly - mechanical alignment check - should be accomplished when a receiver converter is fitted to a retraction package.

- a. Down stop engagement on both sides shall be adjusted for minimum contact unbalance with the receiver converter in its fully extended position (no extension load), to prevent excessive warpage within the receiver-converter main casting.
- b. With the receiver converter fully extended, the angular dimension of  $72^{\circ} \pm 0^{\circ} 15'$  shown in figure 7 should be verified.

5.1.7 Receiver-converter assembly - mechanical alignment check - fixed turret (refer to figure 8).

5.2 Electrical.

5.2.1 Aircraft power]

5.2.1.1 Aircraft power characteristics. The characteristics of the electrical power supplied to the AN/AAS-36 shall be as follows:

- a. AC Power - The AC power system shall be a 3 phase, 4-wire WYE System, having a nominal voltage of 115/200 VRMS and a nominal frequency of 400 Hertz. The neutral point of the source of power is connected to ground and the ground is considered the fourth conductor. The AC power characteristics shall be within the limits of MIL-STD-704A for category B equipment.
- b. DC Power - The DC power system shall be a 2-wire, grounded system having a nominal voltage of 28 VDC. The negative of the power source is connected to ground and ground is considered the second wire. The DC power characteristics shall be within the limits of MIL-STD-704A for category B equipment.

MIL-HDBK-258(AS)

5.2.2 Equipment power requirements.

5.2.2.1 AN/AAS-36 input power. The AN/AAS-36 equipment shall operate within specified limits when supplied with category B, MIL-STD-704A power except as modified herein. The equipment shall operate within the bounds of MIL-STD-704A, figure 3, limits 2 and 3, except the lower limit of curve 3 shall not fall below 80 volts. Equipment malfunction may occur when the input voltage exceeds the above limits but remains within limits 1 and 4 (MIL-STD-704A, figure 3). However, no damage to the equipment shall result when subjected to the following conditions:

- a. Loss of power - Accidental or deliberate stoppage of electrical power, regardless of the time in equipment operating cycle and regardless of duration of stoppage.
- b. Under and overvoltage - Voltages below the minimum or up to 125 percent of the maximum emergency steady state specified in MIL-STD-704A.
- c. Transients - Transient voltage surges that, when converted to their equivalent step functions, are within the limits of figure 3 of MIL-STD-704A.
- d. Phase Reversal or Phase Loss - The reversal of any AC phase or the loss of any combination of AC phases.

Normal operation of equipment shall be automatically resumed upon return of the input voltage to levels within limits 2 and 3 (MIL-STD-704A, figure 3) as modified herein, and/or restoration of proper rotation.

5.2.2.2 AN/AAS-36 input power requirements. Maximum power requirements for the infrared detecting set are as follows:

3 phase 115/200 VRMS	3000 VA
28 VDC	140 VA
18 VDC	28 VA

The IRDS power requirements as a function of operating mode are presented in table I.

TABLE I. IRDS input power requirements (maximum steady state).

Power Input	Standby Excluding Heat Exchanger	Operational Modes Excluding Heat Exchanger And Receiver Slewing	Operational Modes Receiver Slewing Power Only	Operational Modes Heat Exchanger Only
115 VAC, 3Ø	613 VA	955 VA	297 VA	1341 VA
28 VDC	7.26 VA	14.56 VA	-	3.64 VA
18 VDC	-	18 VA	-	-

IRDS panel lighting requires 5 to 28 VDC power (0.5 amps at 28 VDC)

5.2.2.3 IRDS/aircraft electrical system interface. Overall interface of the IRDS and aircraft 3 phase 115/200 VRMS and 28 VDC primary power sources and 18 VDC indicator lamp power source is presented in figure 9.

5.2.2.3.1 IRDS/aircraft electrical system interface. A 5 to 28 VDC panel edge light power signal is provided to the IRDS control, detecting set. The edge panel light load shall be 0.5 amp maximum.

5.2.2.3.2 IRDS/lamp test power source interface. An 18 VDC indicator lamp test signal is provided to the IRDS control, detecting set. The indicator lamp test load shall be 1.0 amp maximum.

5.2.3 Interconnection diagrams. Electrical interconnections are required between the six IRDS weapon replaceable assemblies (WRA) and between the applicable IRDS WRA's and other aircraft systems. Cable division and a cable connection identification chart are presented in figure 10, IRDS interconnection block diagram.

5.2.4 Cabling details. Detailed cabling information, including connector pin assignments, and conductor signal function for the IRDS and associated aircraft subsystem interconnections (illustrated in figure 10) is presented in an interwiring listing (table II) on pages 23 through 59. This listing provides the point-to-point wiring requirements between IRDS WRA's and between IRDS and associated aircraft subsystems. The wiring data is applicable for any IRDS installation and does not identify wire segments peculiar to a particular installation.

5.2.5 Ground/bonding. The ground/bonding practices employed in the installation of IRDS electronic circuits in the aircraft shall be in

MIL-HDBK-258(AS)

accordance with requirements of WR-101 Part I and as qualified herein. IRDS grounding, bonding of cable chassis connectors to IRDS WRA's and preparation of IRDS WRA metallic mating surfaces, for bonding, where applicable, shall be in accordance with WR-101 Part I.

5.2.5.1 Aircraft interconnecting cables. All interconnecting cables between the receiver-converter WRA and other IRDS WRA's and between the receiver-converter WRA and other aircraft circuits shall include an overall tight braid shield which will be adequately terminated on the appropriate back-shell of each connector. The overall shield shall not be interconnected through connector pins. Conductive "Y" or "T" transitions or comparable components shall be used at cable splits to insure that no discontinuities in the overall shield will occur in branched cables.

5.2.6 Video characteristics. Independent and essentially identical video output signals are provided at each of three output connectors on the power supply/video converter WRA (2J7, 2J8, 2J9). Each output is single ended and capable of driving a properly matched 75 ohm video line. TV and timing and amplitude format of the video signals is in accordance with EIA RS-343-A, 4:3 aspect ratio, 875 horizontal line rate at 30 frames/see, with 2:1 interlace. The output connectors are triaxial type (DAGE 2677-1). One video output, (2J7), is connected to the video indicator WRA (6J2) via 75 ohm triaxial transmission line (Raychem 7524D511 or equivalent). Two video outputs (2J8, 2J9) are spares and provided as Inputs to a GFE conventional video recording/playback unit, a GFE auxiliary display unit or a GFE data link unit. Connections between the video output connectors of the power supply and the auxiliary GFE shall be as described for the video indicator interface.

5.3 AN/AAS-36 data system interfaces. The IRDS provides data interfaces with aircraft data processing systems such as (for P-3C installations) the AN/ASQ-114 Digital Computer/AN/AYA-8 Data Analysis Programming group and the CV-2461 A/A Signal Data Converter. Figure 11 is a functional illustration of a typical (P-3C) IRDS/aircraft data processing system interface configuration.

5.3.1 AN/AAS-36 data processing system interface (P-3C). In the CPTR TRK mode of operation, the IRDS will receive rate commands from the P-3 computer via the digital output multiplexer (DOM) channel 14 of logic unit 1 (LU-1) of data analysis programming group AN/AYA-8. Azimuth and elevation gimbal rate signals will be provided to the IRDS via a one way digital data transfer in accordance with the following:

- a. Computer program initiates a normal Output buffer for the channel assigned to the DOM.

- b. The DOM sets the output data request (ODR) line indicating it is in a condition to accept data.
- c. The CP-901 I/O subunit detects the ODR and at its convenience places 12 data bits and 4 address bits (identifies peripheral to accept data) on 16 computer data lines.
- d. The DOM transmits the 12 data bits to each peripheral being serviced by the assigned computer channel.
- e. The computer sets the output acknowledge (OA) line indicating data is stable and ready for sampling.
- f. The DOM decodes the address bits and sends the OA to the applicable peripheral.
- g. The peripheral sample data.
- h. Computer drops to OA to DOM.
- i. DOM drops the OA to peripheral.

The data lines to peripheral will be stable during the period when the OA is active (logic '1') in accordance with the timing diagram presented in figure 12. Overall interface of LU-1 DOM channel 14 with IRDS control, servomechanism unit is illustrated in figure 13. Detailed electrical and mechanical Information for individual data line 1/ and the output acknowledge control line between LU-1 and IRDS control servomechanism unit is provided in figures 14 through 16. Logic voltage levels, transition times and interface timing requirements specified shall exist at the line driver output circuit terminals with the specified maximum cable length and circuit loads connected.

5.3.1.1 Data update timing requirements. System design assumes that the computer will supply data updates (azimuth and elevation angle rate commands) at approximately a 10 Hz rate. To discriminate between data updates and between the first (AZ) and second (EL) words of data updates, the IRDS control servomechanism imposes the following timing requirements upon data from the computer (see figure 17).

1/ Electrical and mechanical interface details for data bits 00 and 11, LSB and MSB respectively, is provided. Details for data bits 01 through 10 are identical with the exception of connector pin assignment, which can be obtained from figure 13.

MIL-HDBK-258(AS)

- a. In general a data word from the computer is interpreted as the first word of a data update unless timing requirement b., below is satisfied.
- b. A word is recognized as the second word of an update only if it is received within 5 milliseconds of a previous word that was recognized as the first word of a data update.
- c. When the control, servomechanism has both words of a data update, it uses that data to change the platform control signals and prepares to accept new data from the computer. The first word of a new data update can follow the second word of the previous data update by as little as 0.1 millisecond. As shown by figure 17, this time interval would ordinarily be in the range of 95 to 110 milliseconds ( $\approx$  10 Hz). Response to data rates greater than 10 Hz will be limited by single pole filtering with a time constant of 0.1 second.

5.3.1.2 Data bit identification. The angle rate commands shall be in sign-magnitude format as shown in table III. The sign (bit 11) convention is as follows:

- a. Azimuth - when viewed from above, the aircraft centerline looking forward shall be 0°, positive angles CW and negative angles CCW.
- b. Elevation - when viewed from the cockpit, looking forward (parallel to aircraft centerline) shall be 0°, positive angles up and negative angles down.

5.3.2 AN/AAS-36 data processing system status logic interface. The IRDS control servomechanism unit will provide two status signals to the data processing system. A typical (P-3C) status logic interface of the control servomechanism unit with the data processing system is presented in figure 18. Detailed electrical and mechanical information for the individual status signals is presented in figures 19 and 20. Voltage levels specified shall exist across the line driver output circuit terminals with the specified maximum cable lengths and circuit loads connected.

5.3.2.1 IRDS status logic signals. The two status signals supplied by the IRDS to the aircraft computer are:

- a. Computer track - informs computer that IRDS mode select switch is in computer track position and IRDS equipment is not performing built-in test (BIT).

- b. Manual track override - informs computer that the trigger of the target tracking sight control is depressed, i.e., subsystem is in manual track mode.

5.3.3 AN/AAS-36 synchro data interface. The IRS control servo-mechanism unit will provide azimuth and elevation gimbal position readout signals to the aircraft data processing systems, in synchro form. The gimbal position signals will utilize 11.8 V, 400 Hz, 3 wire synchro format compatible with synchro to digital converters such as the CV-2461 A/A. Typical (P-3C) electrical and mechanical synchro interface details are presented in figures 21 and 22.

5.3.3.1 Synchro excitation reference. The aircraft data processing system must provide a 26 V, 400 Hz excitation signal for the azimuth and elevation position synchro transmitters in the IRDS receiver-converter, via the control servomechanism unit. Detailed electrical and mechanical interface information for the synchro reference signal is presented in figure 23. Typical (P-3C) overall wiring details for the IRDS synchro signals and the 26 VAC reference is provided in figure 24.

5.3.3.2 Electrical zero. The following method can be implemented to provide a coarse electrical zero verification. This is not an accurate test, but will determine which of two possible null positions correspond to electrical zero.

All signals necessary for this determination are present on 3J3, the control-servomechanism WRA to aircraft interface connector. They are R1 (26 VAC 400 Hz LO), R2 (26 VAC 400 Hz HI), AS1, AS2, AS3 (azimuth synchro S1, S2 and S3) and ES1, ES2, ES3 (elevation synchro S1, S2 and S3). Detail pin connections are provided in figure 24. The AN/AAS-36 must be energized through 3J3. A means of break-out of these signals will be required. An oscilloscope with two vertical input channels will be used with horizontal time base synchronized to channel 2. Convert R2 to channel 2 vertical input.

Procedures:

- a. Initially point the system LOS to approximately boresight. All cables must be connected for test, but system power (mode switch) may be off.
- b. For azimuth axis, connect AS1 and AS3 together, and to channel 1 of the scope. Connect AS2 to R1 together and connect to scope return - if the proper electrical zero has been chosen, the two waveforms displayed will be approximately in time phase. If incorrect electrical zero has been chosen, the two waveforms will be approximately 180° out of time phase.

MIL-HDBK-258(AS)

- c. For elevation axis, repeat b. except use ES1, ES2 and ES3 instead of AS1, AS2 and AS3.

5.4 AN/AAS-36 electrical interlocks.

5.4.1 AN/AAS 36 maintenance switch. The IRDS receiver-converter will interface with a remote receiver-converter maintenance switch. The maintenance switch will be a 3 position device which establishes the following operating conditions:

- a. Upper position (normal) - normal receiver converter operation
- b. Center position (gimbal disable) - normal receiver-converter operation except power (+30 VDC) is removed from the gimbal drive mechanism.
- c. Lower position (brake release) - same as center Position except, gimbal brake release connections are made through the maintenance switch to the receiver-converter. Brake release high (Hi), +28 VDC (when enabled) and brake release low (Lo), a ground.

Figure 25 details the overall interfaces of the *receiver* converter and the *aintenance* switch.

6. COGNIZANCE

6.1 This handbook is under the engineering cognizance of AIR-549332.

Preparing Activity-NAVY AS  
Project No. 5855-0028

TABLE II. IRDS interwiring list.

WIRE NO.	FROM CONNECTOR PIN	TO CONNECTOR PIN	FUNCTION	CURR AMP	WIRE SIZE	REMARKS
1	1J1-A					NO CONTACT
2	1J1-B					NO CONTACT
3	1J1-C					NO CONTACT
4	1J1-D	2J4-D	VIDEO HI		22	75 OHM VIDEO RG-108 TWIN AX SHIELD TERMINATED AT 1J1-F AND 2J4-F
5	1J1-E	2J4-E	VIDEO LO		22	
6	1J1-F	2J4-F	VIDEO SHIELD			
7	1J1-G					NOT USED
8	1J1-H					NOT USED
9	1J1-J	2J4-J	POST AMP +10 VDC HI	1.6	22	SHIELDED TWISTED PAIR (SHIELD TO NO. 19)
10	1J1-K	2J4-K	POST AMP +10 VDC RETURN	1.6	22	
11	1J1-L	2J4-L	FOCUS +15 VDC	.5	22	TWISTED TRIPLET, W/ NO. 33
12	1J1-M	2J4-M	FOCUS -15 VDC	.5	22	
13	1J1-N	2J4-N	POST AMP -9 VDC HI	1.6	22	SHIELDED TWISTED PAIR (SHIELD TO NO. 19)
14	1J1-P	2J4-P	POST AMP -9 VDC RETURN	1.6	22	

MIL-HDBK-258(AS)

TABLE II. IRDS Interwiring List. - Continued

WIRE NO.	FROM CONNECTOR PIN	TO CONNECTOR PIN	FUNCTION	CURR AMP	WIRE SIZE	REMARKS
15	1J1-R	2J4-R	+5 VDC BITE RETURN	1.2	22	TWISTED PAIR
16	1J1-S	2J4-S	+5 VDC BITE HI	1.2	22	
17	1J1-T	2J4-T	PREAMP +10 VDC HI	1.8	22	SHIELDED TWISTED PAIR (SHIELD TO NO. 19)
18	1J1-U	2J4-U	PREAMP +10 VDC RETURN	1.8	22	
19	1J1-V	2J4-V	SHIELD FOR WIRES NO. 9-10, 13-14, 17-18, 20-21	0		SHIELD TERMINATED AT 1J1-V AND 2J4-V
20	1J1-W	2J4-W	PREAMP SENSE HI	.2	22	SHIELDED TWISTED PAIR (SHIELD TO NO. 19)
21	1J1-X	2J4-X	PREAMP SENSE RETURN	.2	22	
22	1J1-Y	2J4-Y	+10 VDC SENSE HI	.02	22	SHIELDED TWISTED PAIR (SHIELD TO NO. 28)
23	1J1-Z	2J4-Z	+10 VDC SENSE RETURN	.02	22	
24	1J1-ZA	2J4-ZA	SYSTEM INTERLOCK	.13	22	TWISTED PAIR AT 28 VDC
25	1J1-ZB	2J4-ZB	SYSTEM INTERLOCK	.13	22	
26	1J1-ZC	2J4-ZC	SPARE		22	
27	1J1-ZD	2J4-ZD	OVERHEAT HI	.002	22	5 VDC SWITCHED
28	1J1-ZE	2J4-ZE	SHIELD FOR WIRES NO. 22-23, 40-41			SHIELD TERMINATED AT 1J1-ZE AND 2J4-ZE
29	1J1-ZF	2J4-ZF	CAMERA PREHEAT	.6	22	5 VDC SWITCHED

TABLE II. IRDS interwiring list. - Continued

WIRE NO.	FROM CONNECTOR PIN	TO CONNECTOR PIN	FUNCTION	CURR AMP	WIRE SIZE	REMARKS
30	1J1-ZG	2J4-ZG	SPARE		22	
31	1J1-ZH	2J4-ZH	SPARE		22	
32	1J1-ZI	2J4-ZI	SPARE		22	
33	1J1-ZJ	2J4-ZJ	±15 VDC RETURN	.5	22	TWISTED TRIPLET W/ NO. 11,12
34	1J1-ZK	2J4-ZK	+14 VDC	3.0	20	TWISTED TRIPLET WITH NO. 49
35	1J1-ZM	2J4-ZM	±14 VDC RETURN	4.0	20	
36	1J1-ZN	2J4-ZN	RECEIVER TOO COLD		22	NO LOAD IN UNIT 2
37	1J1-ZP	2J4-ZP	SPARE		22	
38	1J1-ZQ	2J4-ZQ	RECEIVER BITE	.002	22	5 VDC SWITCHED
39	1J1-ZR	2J4-ZR	RECEIVER BITE INHIBIT		22	NO LOAD IN UNIT 2
40	1J1-ZS	2J4-ZS	LED +10 VDC HI	4.5	20	SHIELD-TWISTED PAIR (SHIELD PICKED UP AT NO. 28)
41	1J1-ZT	2J4-ZT	LED +10 VDC RETURN	4.5	20	
42	1J1-ZU	2J4-ZU	BEAM DRIVE IN	.01	22	SHIELDED TWISTED TRIPLET WITH NO. 44,45
43	1J1-ZV	2J4-ZV	VERT SYNC	.01	22	SHIELDED TWISTED TRIPLET WITH NO. 46,47

MIL-HDBK-258(AS)

TABLE II. IRDS Interwiring list. - Continuec

WIRE NO.	FROM CONNECTOR PIN	TO CONNECTOR PIN	FUNCTION	CURR AMP	WIRE SIZE	REMARKS
44	1J1-ZW	2J4-ZW	HORIZ DRIVE	.03	22	SHIELDED TWISTED TRIPLET WITH NO. 42
45	1J1-ZX	2J4-ZX	CATHODE DRIVE	.03	22	
46	1J1-ZY	2J4-ZY	DARK CURRENT SAMPLE	.03	22	SHIELDED TWISTED TRIPLET WITH NO. 43
47	1J1-ZZ	2J4-ZZ	CAMERA PEAK DET ENABLE	.03	22	
48	1J1-AA	2J4-AA	SHIELDS FOR WIRES NO. 42, 44, 45 AND 43, 46, 47			SHIELD TERMINATED AT 1J1-AA AND 2J4-AA
49	1J1-BB	2J4-BB	-14 VDC	3.0	20	TWISTED TRIPLET W/ NO. 34, 35
50	1J1-CC	2J4-CC	SPARE		22	NO CONTACT
51	1J1-DD	2J4-DD	SPARE		22	NO CONTACT
52	1J1-EE					
53	1J1-FF					
54	1J1-GG	2J4-GG	SCAN SYNC	.01	22	TWISTED PAIR 5 VDC SWITCHED
55	1J1-HH	2J4-HH	SCAN SYNC RETURN	.01	22	
56	1J1-JJ	2J4-JJ	CAMERA BITE	.02	22	5 VDC SWITCHED

TABLE II. IRDS interwiring list. - Continued

WIRE NO.	FROM CONNECTOR PIN	TO CONNECTOR PIN	FUNCTION	CURR AMP	WIRE SIZE	REMARKS
57	1J1-KK	2J4-KK	CAMERA +40 VDC	.3	22	SHIELDED TWISTED QUAD SHIELD TERMINATED AT 1J1-PP AND 2J4-PP
58	1J1-LL	2J4-LL	CAMERA +8.5 VDC	.8	22	
59	1J1-MM	2J4-MM	CAMERA -8.5 VDC	.5	22	
60	1J1-NN	2J4-NN	CAMERA RETURN	2.0	22	
61	1J1-PP	2J4-PP	SHIELD FOR WIRES NO. 57-60			
62	1J2-A	2J2-V	SPARE		22	TWISTED PAIR
63	1J2-B	2J2-W	SPARE		22	NO CONTACTS IN 1J2
64	1J2-C	2J2-C	SPARE		22	NO CONTACT IN 1J2
65	1J2-D	2J2-F	SPARE		22	NO CONTACT IN 1J2
66	1J2-E					NO CONTACT
67	1J2-F	2J3-A	SPARE		22	TWISTED TRIPLET NO CONTACTS IN 1J2
68	1J2-G	2J3-B	SPARE		22	
69	1J2-H	2J3-C	SPARE		22	
70	1J2-J					NO CONTACT
71	1J2-K					NO CONTACT

MIL-HDBK-258(AS)

TABLE II. IRDS interwiring list. - Continued

WIRE NO.	FROM CONNECTOR PIN	TO CONNECTOR PIN	FUNCTION	CURR AMP	WIRE SIZE	REMARKS
72	1J2-L					NO CONTACT
73	1J2-M	2J3-JJ	SAFETY GROUND	0	20	NO CONTACT
74	1J2-N					NO CONTACT
75	1J2-P	2J3-ZQ	SCAN -5 VDC HI	1.0	20	} TWISTED PAIR 0.15 V MAX LINEDROP
76	1J2-R	2J3-ZR	SCAN -5 VDC RETURN	1.0	20	
77	1J2-S	2J3-ZN	SCAN +5 VDC HI	1.0	20	} TWISTED PAIR 0.15 V MAX LINEDROP
78	1J2-T	2J3-ZP	SCAN +5 VDC RETURN	1.0	20	
79	1J2-U	2J3-EE	SCAN +15 VDC HI	1.1	20	} TWISTED PAIR 0.25 V MAX LINEDROP
80	1J2-V	2J3-FF	SCAN +15 VDC RETURN	1.1	20	
81	1J2-W	2J3-GG	SCAN -15 VDC HI	1.1	20	} TWISTED PAIR 0.25 V MAX LINEDROP
82	1J2-X	2J3-HH	SCAN -15 VDC RETURN	1.1	20	
83	1J2-Y	2J3-ZT	SPARE		22	NO CONTACT IN 1J2

TABLE II. IRDS interwiring list. - Continued

WIRE NO.	FROM CONNECTOR PIN	TO CONNECTOR PIN	FUNCTION	CURR AMP	WIRE SIZE	REMARKS
84	1J2-Z	2J3-ZA	SPARE		22	NO CONTACT IN 1J2
85	1J2-ZA	1J2-ZB	SYSTEM INTERLOCK	.13	22	
86	4J1-J					INTERNALLY CONNECTED. DO NOT USE.
87	1J2-ZC	2J2-A	SPARE		22	TWISTED PAIR NO CONTACTS IN 1J2
88	1J2-ZD	2J2-B	SPARE		22	
89	1J2-ZE	2J2-G	SPARE		22	NO CONTACT IN 1J2
90	1J2-ZF	2J2-H	SPARE		22	NO CONTACT IN 1J2
91	1J2-ZG	2J3-D	SPARE		22	NO CONTACT IN 1J2
92	1J2-ZH	2J3-E	SPARE		22	NO CONTACT IN 1J2
93	1J2-ZI					NO CONTACT
94	1J2-ZJ					NO CONTACT
95	1J2-ZK	2J3-KK	+28 VDC HI	2.0	20	TWISTED PAIR RELAY SWITCHED
96	1J2-ZM	2J3-LL	28 VDC RETURN	2.0	20	
97	1J2-ZN					NO CONTACT
98	1J2-ZP					NO CONTACT

MIL-HDBK-258 (AS)

TABLE II. IRDS interwiring list. - Continued

WIRE NO.	FROM CONNECTOR PIN	TO CONNECTOR PIN	FUNCTION	CURR AMP	WIRE SIZE	REMARKS
99	1J2-ZP					NO CONTACT
100	1J2-ZR					NO CONTACT
101	1J2-ZS					NO CONTACT
102	1J2-ZT					NO CONTACT
103	1J2-ZU					NO CONTACT
104	1J2-ZV					NO CONTACT
105	1J2-ZW					NO CONTACT
106	1J2-ZX					NO CONTACT
107	1J2-ZY					NO CONTACT
108	1J2-ZZ		GIMBAL DISABLE	.13	22	SHORT TOGETHER FOR NORMAL OPERATION, OPEN FOR GIMBAL DISABLE
109	1J2-AA	TO IRDS MAINTENANCE SWITCH SEE FIGURE 25.	+30 VDC OUT	.13	22	
110	1J2-BB		REMOTE BRAKE HI	1.0	20	FOR REMOTE GIMBAL BRAKE RELEASE SUPPLY EXTERNAL +28 V (HI) AND RETURN (LO)
111	1J2-CC		REMOTE BRAKE LO	1.0	20	

TABLE II. IRDS interwiring list. - Continued

WIRE NO.	FROM CONNECTOR PIN	TO CONNECTOR PIN	FUNCTION	CURR AMP	WIRE SIZE	REMARKS
112	1J2-DD	1J2-EE	SYSTEM INTERLOCK	.13	22	SHORT TOGETHER FOR IRDS OPERATION
113						
114	1J2-FF	2J2-ZE	SHIELD FOR WIRES NO. 115-118, 119-122			SHIELD TERMINATED AT 1J2-FF AND 2J2-ZE
115	1J2-GG	2J2-ZD	HEAT EXCHANGER 115 VAC 400 HZ NEUT	11.7	20	SHIELDED TWISTED QUAD (SHIELD TO NO. 114)
116	1J2-HH	2J2-ZC	HEAT EXCHANGER 115 VAC 400 HZ PH C	3.9	20	
117	1J2-JJ	2J2-ZB	HEAT EXCHANGER 115 VAC 400 HZ PH B	3.9	20	
118	1J2-KK	2J2-ZA	HEAT EXCHANGER 115 VAC 400 HZ PH A	3.9	20	
119	1J2-LL	2J2-ZJ	STANDBY 115 VAC 400 HZ NEUT	1.2	20	
120	1J2-MM	2J2-ZF	STANDBY 115 VAC 400 HZ PH A	.41	20	
121	1J2-NN	2J2-ZG	STANDBY 115 VAC 400 HZ PH B	.41	20	SHIELDED TWISTED QUAD (SHIELD TO NO. 114)
122	1J2-PP	2J2-ZH	STANDBY 115 VAC 400 HZ PH C	.41	20	

MIL-HDBK-258(AS)

TABLE II. IRDS interwiring list. - Continued

WIRE NO.	FROM CONNECTOR PIN	TO CONNECTOR PIN	FUNCTION	CURR AMP	WIRE SIZE	REMARKS
123	3J2-A	4J1-G	SPARE		22	TWISTED PAIR WITH NO. 147
124	3J2-B	2J3-Z	SPARE		22	
125	3J2-C	2J3-Y	SPARE		22	
126	3J2-D	2J3-X	SPARE		22	
127	3J2-E	2J3-W	SPARE		22	
128	3J2-F	2J3-ZH	GYRO READY HI	.002	22	5 VDC SWITCHED
129	3J2-G	2J3-ZI	STOW FEEDBACK	.02	22	-10 TO +10 VDC
130	3J2-H	2J3-ZZ	GAI AZ DC HI	.001	22	SHIELDED TWISTED PAIR ±15 VAC ANALOG, SHIELD NO. 134
131	3J2-J	2J3-AA	GAI AZ DC LO	.001	22	
132	3J2-K	2J3-BB	GAI EL DC HI	.001	22	SHIELDED TWISTED PAIR ±15 VDC ANALOG, SHIELD NO. 134
133	3J2-L	2J3-CC	GAI EL DC LO	.001	22	
134	3J2-M	2J3-DD	SHIELD FOR WIRES NO. 130-131, 132-133			SHIELD TERMINATED AT 3J2-M AND 2J3-DD
135	3J2-N	2J3-ZV	SERVO BITE RETURN	.002	22	
136	3J2-P	2J3-ZW	SERVO BITE INITIATE	.002	22	5 VDC SWITCHED

TABLE II. IRDS interwiring list. - Continued

WIRE NO.	FROM CONNECTOR PIN	TO CONNECTOR PIN	FUNCTION	CURR AMP	WIRE SIZE	REMARKS
137	3J2-R	2J3-ZX	SERVO BITE COMP	.002	22	5 VDC SWITCHED
138	3J2-S	2J3-ZY	SERVO BITE	.002	22	5 VDC SWITCHED
139	3J2-T	2J3-NN	+28 VDC HI	1.0	20	TWISTED PAIR RELAY CONTROLLED
140	3J2-U	2J3-PP	+28 VDC RETURN	1.0	20	
141	3J2-V	2J3-MM	SAFETY GND	0	22	
142	3J2-W	2J2-P	SERVO 115 VAC 400 HZ PH A	.55	20	SHIELDED TWISTED QUAD SHIELD TERMINATED AT 3J2-ZA AND 2J2-R
143	3J2-X	2J2-N	SERVO 115 VAC 400 HZ PH B	.55	20	
144	3J2-Y	2J2-M	SERVO 115 VAC 400 HZ PH C	.55	20	
145	3J2-Z	2J2-L	SERVO 115 VAC 400 HZ NEUT	1.65	20	
146	3J2-ZA	2J2-R	SHIELD			TWISTED PAIR W/NO. 123
147	3J2-ZB	4J1-H	SPARE			NOT USED
148	3J2-ZC					NOT USED
149	3J2-ZD					NOT USED

MIL-HDBK-258(AS)

TABLE II. IRDS interwiring list. - Continued

WIRE NO.	FROM CONNECTOR PIN	TO CONNECTOR PIN	FUNCTION	CURR AMP	WIRE SIZE	REMARKS
150	3J2-ZE					NOT USED
151	3J2-ZF					NOT USED
152	3J2-ZG					NOT USED
153	3J2-ZH					NOT USED
154	3J2-ZI	5J1-N	SPARE		22	
155	3J2-ZJ	5J1-P	SPARE		22	
156	3J2-ZK	5J1-R	SPARE		22	
157	3J2-ZM	5J1-ZA	SPARE		22	
158	3J2-ZN	4J1-M	FORWARD COMMAND	.002	22	5 VDC SWITCHED
159	3J2-ZP	4J1-N	POSITION COMMAND	.002	22	5 VDC SWITCHED
160	3J2-ZQ	4J1-P	CPTR TRK COMMAND	.002	22	5 VDC SWITCHED
161	3J2-ZR	4J1-R	MAN TRK COMMAND	.002	22	5 VDC SWITCHED
162	3J2-ZS	4J1-S	STANDBY COMMAND	.002	22	+5 VDC SWITCHED
163	3J2-ZT	4J1-T	OFF COMMAND	.002	22	+5 VDC SWITCHED
164	3J2-ZU	4J1-U	SERVO MODE SELECT	.002	22	+5 VDC SWITCHED

TABLE II. IRDS interwiring list. - Continued

WIRE NO.	FROM CONNECTOR PIN	TO CONNECTOR PIN	FUNCTION	CURR AMP	WIRE SIZE	REMARKS
165	3J2-ZV	4J1-V	SHIELD FOR WIRES NO. 166-168, 169, 171			SHIELD TERMINATED AT 3J2-ZV AND 4J1-V
166	3J2-ZW	4J1-W	EL POS CW	.01	22	SHIELDED TWISTED TRIPLET (SHIELD TO NO. 165) ±15 VDC ANALOG
167	3J2-ZX	4J1-X	EL POS WIPER	.002	22	
168	3J2-ZY	4J1-Y	EL POS CCW	.01	22	
169	3J2-ZZ	4J1-Z	AZ POS CW	.01	22	SHIELDED TWISTED TRIPLET (SHIELD TO NO. 165) ±15 VDC ANALOG
170	3J2-AA	4J1-ZA	AZ POS WIPER	.002	22	
171	3J2-BB	4J1-ZB	AZ POS CCW	.01	22	
172	3J2-CC	5J1-V	AZ MAN RATE HI	.01	22	SHIELDED TWISTED PAIR ±15 VDC ANALOG, SHIELD TO NO. 176
173	3J2-DD	5J1-W	AZ MAN RATE LO	.01	22	
174	3J2-EE	5J1-X	EL MAN RATE HI	.01	22	SHIELDED TWISTED PAIR ±15 VDC ANALOG, SHIELD TO NO. 176
175	3J2-FF	5J1-Y	EL MAN RATE LO	.01	22	
176	3J2-GG	5J1-Z	SHIELD FOR WIRES NO. 172, 173 AND 174, 175			SHIELD TERMINATED AT 3J2-GG AND 5J1-Z
177	3J2-HH	5J1-F	MAN OVRD	.01	22	TWISTED PAIR
178	3J2-JJ	5J1-G	SERVO +5 VDC RETURN	.01	22	

MIL-HDBK-258 (AS)

TABLE II. IRDS interwiring list. - Continued

WIRE NO.	FROM CONNECTOR PIN	TO CONNECTOR PIN	FUNCTION	CURR AMP	WIRE SIZE	REMARKS
179	3J2-KK	5J1-H	+15 VDC HI	.05	22	SHIELDED TWISTED TRIPLET
180	3J2-LL	5J1-J	±15 VDC RETURN	.10	22	
181	3J2-MM	5J1-K	-15 VDC HI	.05	22	
182	3J2-NN	5J1-L	SHIELD			SHIELD TERMINATED AT 3J2-NN AND 5J1-L
183	3J2-PP	5J1-M	SAFETY GROUND		22	
184	4J1-A					INTERNALLY CONNECTED. DO NOT USE.
185	4J1-B					INTERNALLY CONNECTED. DO NOT USE.
186	4J1-C					INTERNALLY CONNECTED. DO NOT USE.
187	4J1-D	2J3-H	SPARE		22	TWISTED TRIPLET
188	4J1-E	2J3-ZB	SPARE		22	
189	4J1-F	2J3-ZC	SPARE		22	

TABLE II. IRDS interwiring list. - Continued

WIRE NO.	FROM CONNECTOR PIN	TO CONNECTOR PIN	FUNCTION	CURR AMP	WIRE SIZE	REMARKS
190	4J1-K	AIRCRAFT LAMP TEST CONTROL	LAMP TEST HI	1.0	22	SUPPLY EXTERNAL +28 VDC (HI) AND RETURN TO TEST CONTROL PANEL INDICATOR LAMPS
191	4J1-L	AIRCRAFT LAMP TEST CONTROL	LAMP TEST RETURN	1.0	22	
192	4J1-ZC	2J3-V	GRAY SCALE HI	.02	22	28 VDC SWITCHED
193	4J1-ZD	2J3-U	+28 VDC RETURN	.10	20	
194	4J1-ZE	2J3-ZU	SAFETY GROUND	0	22	
195	4J1-ZF	2J3-R	SYSTEM GO	.13	22	+18 VDC SWITCHED
196	4J1-ZG	2J3-P	RCVR FAIL	.13	22	+18 VDC SWITCHED
197	4J1-ZH	2J3-N	POWER SUPPLY FAIL	.13	22	+18 VDC SWITCHED
198	4J1-ZI	2J3-M	SERVO FAIL	.13	22	+18 VDC SWITCHED
199	4J1-ZJ	2J3-L	NOT READY	.13	22	+18 VDC SWITCHED
200	4J1-ZK	2J3-K	BIT SWITCH	.13	22	+18 VDC SWITCHED
201	4J1-ZM	2J3-J	OVERTEMP	.13	22	+18 VDC SWITCHED
202	4J1-ZN	2J3-S	GO RESET	.005	22	5 VDC SWITCHED

MIL-HDBK-258(AS)

TABLE II. IRDS interwiring list. - Continued

WIRE NO.	FROM CONNECTOR PIN	TO CONNECTOR PIN	FUNCTION	CURR AMP	WIRE SIZE	REMARKS
203	4J1-ZP	2J3-T	BIT INDICATOR	.13	22	+18 VDC SWITCHED
204	4J1-ZQ	2J3-G	+28 VDC SUPPLY	.5	22	TWISTED TRIPLET +28 VDC SWITCHES
205	4J1-ZR	2J3-F	STANDBY COMMAND	.13	22	
206	4J1-ZS	2J3-ZG	OPERATE COMMAND	.26	22	
207	4J1-ZT					INTERNALLY CONNECTED. DO NOT USE.
208	4J1-ZU	2J3-ZS	+18 VDC SUPPLY	1.0	20	
209	4J1-ZV					INTERNALLY CONNECTED. DO NOT USE.
210	4J1-ZW	AIRCRAFT PANEL LIGHT SUPPLY	PANEL LIGHT SUPPLY	.4	22	TWISTED PAIR W/NO. 212
211	4J1-ZX					INTERNALLY CONNECTED. DO NOT USE.
212	4J1-ZY	AIRCRAFT PANEL LIGHT CONTROL	PANEL LIGHT RETURN	.4	22	TWISTED PAIR W/NO. 210
213						
214	4J1-AA	4J1-ZZ	SYSTEM INTERLOCK	0.13	22	

TABLE II. IRDS interwiring list. - Continued

WIRE NO.	FROM CONNECTOR PIN	TO CONNECTOR PIN	FUNCTION	CURR AMP	WIRE SIZE	REMARKS
215	4J1-BB					INTERNALLY CONNECTED. DO NOT USE.
216	4J1-CC					INTERNALLY CONNECTED. DO NOT USE.
217	4J1-DD					INTERNALLY CONNECTED. DO NOT USE.
218	4J1-EE					INTERNALLY CONNECTED. DO NOT USE.
219	4J1-FF	2J3-ZJ	FOCUS +15 VDC	.01	22	} TWISTED TRIPLET
220	4J1-GG	2J3-ZK	FOCUS -15 VDC	.01	22	
221	4J1-HH	2J3-ZM	FOCUS ±15 VDC RETURN	.01	22	
222	2J2-D	2J2-E	INTERLOCK	.13	22	
223	6J1-A	2J2-Z	DISPLAY 115 VAC 400 HZ PH B	.82	20	} SHIELDED TWISTED PAIR DISPLAY POWER SHIELD TERMINATED AT 6J1-C AND 2J2-Y
224	6J1-B	2J2-J	DISPLAY 115 VAC 400 HZ NEUT	.82	20	
225	6J1-C	2J2-Y	SHIELD			
226	2J2-K					NO CONTACT

MIL-HDBK-258 (AS)

TABLE II. IRDS interwiring list. - Continued

WIRE NO.	FROM CONNECTOR PIN	TO CONNECTOR PIN	FUNCTION	CURR AMP	WIRE SIZE	REMARKS
227	2J2-X					NO CONTACT
228	2J2-S					INTERNALLY CONNECTED. DO NOT USE.
229	2J2-T					INTERNALLY CONNECTED. DO NOT USE.
230	2J2-U					INTERNALLY CONNECTED. DO NOT USE.
231	2J2-ZK					NOT USED
232	2J3-ZD					INTERNALLY CONNECTED. DO NOT USE.
233	2J3-ZE					INTERNALLY CONNECTED. DO NOT USE.
234	2J3-ZF					INTERNALLY CONNECTED. DO NOT USE.
235	5J1-A					INTERNALLY CONNECTED. DO NOT USE.
236	5J1-B					INTERNALLY CONNECTED. DO NOT USE.
237	5J1-C					INTERNALLY CONNECTED. DO NOT USE.

TABLE II. IRDS interwiring list. - Continued

WIRE NO.	FROM CONNECTOR PIN	TO CONNECTOR PIN	FUNCTION	CURR AMP	WIRE SIZE	REMARKS
238	5J1-D					INTERNALLY CONNECTED. DO NOT USE.
239	5J1-E					INTERNALLY CONNECTED. DO NOT USE.
240	5J1-S					INTERNALLY CONNECTED. DO NOT USE.
241	5J1-T					INTERNALLY CONNECTED. DO NOT USE.
242	5J1-U		SPARE			NOT USED
243	5J1-ZB					INTERNALLY CONNECTED. DO NOT USE.
244	5J1-ZC					INTERNALLY CONNECTED. DO NOT USE.
245	1J4-A	3J1-A	SPARE		22	SHIELDED TWISTED PAIR SHIELD TERMINATED AT 1J4-C AND 3J1-C
246	1J4-B	3J1-B	SPARE		22	
247	1J4-C	3J1-C	SHIELD			
248	1J4-D	3J1-D	+30 VDC SUPPLY	.13	20	TWISTED PAIR 28 VDC TO RELAY
249	1J4-E	3J1-E	GIMBAL DISABLE	.13	20	

MIL-HDBK-258(AS)

TABLE II. IRDS interwiring list. - Continued

WIRE NO.	FROM CONNECTOR PIN	TO CONNECTOR PIN	FUNCTION	CURR AMP	WIRE SIZE	REMARKS
250	1J4-F	3J1-F	BRAKE HI	1.0	20	TWISTED PAIR 28 VDC SWITCHED
251	1J4-G	3J1-G	BRAKE LO	1.0	20	
252	1J4-H	3J1-H	SHIELD			SHIELD TERMINATED AT 1J4-H AND 3J1-H SHIELDED TWISTED TRIPLET SERVO
253	1J4-J	3J1-J	SERVO +15 VDC HI	.5	22	
254	1J4-K	3J1-K	SERVO ±15 VDC RETURN	.5	22	
255	1J4-L	3J1-L	SERVO -15 VDC HI	.5	22	TWISTED PAIR SYNCHRO EXCITATION
256	1J4-M	3J1-M	26 VAC ∠0° EXCITATION	.14	22	
257	1J4-N	3J1-N	26 VAC ∠0° RETURN	.14	22	SHIELD TERMINATED AT 1J4-R AND 3J1-R SHIELDED TWISTED PAIR ±15 VDC ANALOG
258	1J4-P	3J1-P	SPARE		22	
259	1J4-R	3J1-R	SHIELD			SHIELDED TWISTED TRIPLET ±15 VDC ANALOG SHIELD TO NO. 265
260	1J4-S	3J1-S	AZ RATE HI	.01	22	
261	1J4-T	3J1-T	AZ RATE LO	.01	22	
262	1J4-U	3J1-U	EL POS POT CW	.01	22	SHIELDED TWISTED TRIPLET ±15 VDC ANALOG SHIELD TO NO. 265
263	1J4-V	3J1-V	EL POS POT WIPER	.001	22	
264	1J4-W	3J1-W	EL POS POT CCW	.01	22	

TABLE II. IRDS interwiring list. - Continued

WIRE NO.	FROM CONNECTOR PIN	TO CONNECTOR PIN	FUNCTION	CURR AMP	WIRE SIZE	REMARKS
265	1J4-X	3J1-X	SHIELD TO WIRES NO. 262-264			SHIELD TERMINATED AT 1J4-X AND 3J1-X
266	1J4-Y	3J1-Y	AZ RESOLVER S1	.01	22	
267	1J4-Z	3J1-Z	AZ RESOLVER S3	.01	22	
268	1J4-ZA	3J1-ZA	AZ RESOLVER S2	.01	22	
269	1J4-ZB	3J1-ZB	AZ RESOLVER S4	.01	22	
270	1J4-ZK	3J1-ZK	EL RESOLVER S1	.01	22	
271	1J4-ZM	3J1-ZM	EL RESOLVER S3	.01	22	
272	1J4-ZN	3J1-ZN	EL RESOLVER S2	.01	22	
273	1J4-ZP	3J1-ZP	EL RESOLVER S4	.01	22	
274	1J4-ZW	3J1-ZW	SHIELD			SHIELD TERMINATED AT 1J4-ZW AND 3J1-ZW
275	1J4-ZC	3J1-ZC	GYRO TEMP RETURN	.01	22	
276	1J4-ZD	3J1-ZD	SHIELD			
277	1J4-ZE	3J1-ZE	SERVO +5 VDC HI	1.0	20	
278	1J4-ZF	3J1-ZF	SERVO +5 VDC RETURN	1.0	20	

MIL-HDBK-258 (AS)

TABLE II. IRDS interwiring list. - Continued

WIRE NO.	FROM CONNECTOR PIN	TO CONNECTOR PIN	FUNCTION	CURR AMP	WIRE SIZE	REMARKS
279	1J4-ZG	3J1-ZG	AZ TACH HI	.01	22	SHIELDED TWISTED PAIR 14 VRMS 400 HZ ANALOG SHIELD TERMINATED AT 1J4-ZI AND 3J1-ZI
280	1J4-ZH	3J1-ZH	AZ TACH LO	.01	22	
281	1J4-ZI	3J1-ZI	SHIELD		22	
282	1J4-ZJ	3J1-ZJ	SPARE		22	
283	1J4-ZQ	3J1-ZQ	EL RATE HI	.01	22	SHIELDED TWISTED PAIR ±15 VDC ANALOG SHIELD TERMINATED AT 1J4-ZS AND 3J1-ZS
284	1J4-ZR	3J1-ZR	EL RATE LO	.01	22	
285	1J4-ZS	3J1-ZS	SHIELD		22	
286	1J4-ZT	3J1-ZT	GYRO TEMP	.005	22	5 VDC SWITCHED
287	1J4-ZU	3J1-ZU	GIMBAL FAIL HI	.002	22	TWISTED PAIR
288	1J4-ZV	3J1-ZV	GIMBAL FAIL LO	.002	22	
289	1J4-ZX					NO CONTACT
290	1J4-ZY	3J1-ZY	+15 VDC SUPPLY	1.0	20	TWISTED PAIR
291	1J4-ZZ	3J1-ZZ	+15 VDC RETURN	1.0	20	
292	1J4-AA					NOT USED
293	1J4-BB	3J1-BB	-15 VDC SUPPLY	1.0	20	TWISTED PAIR
294	1J4-CC	3J1-CC	-15 VDC RETURN	1.0	20	

TABLE II. IRDS interwiring list. - Continued

WIRE NO.	FROM CONNECTOR PIN	TO CONNECTOR PIN	FUNCTION	CURR AMP	WIRE SIZE	REMARKS
295	1J4-DD	3J1-DD	EL TORQ HI	0-4.5	20	SHIELDED TWISTED PAIR ±30 VDC SERVO POWER
296	1J4-EE	3J1-EE	EL TORQ LO	0-4.5	20	
297	1J4-FF	3J1-FF	AZ MOTOR DRIVE HI	0-4.5	20	SHIELDED TWISTED PAIR ±30 VDC SERVO POWER
298	1J4-GG	3J1-GG	AZ MOTOR DRIVE LO	0-4.5	20	
299	1J4-HH	3J1-HH	SHIELD FOR WIRES NO. 295, 296 AND 297, 298		20	SHIELD TERMINATED AT 1J4-HH AND 3J1-HH
300	1J4-JJ	3J1-JJ	SHIELD			SHIELD TERMINATED AT 1J4-JJ AND 3J1-JJ SHIELD-TWISTED TRIPLET ±15 VDC
301	1J4-KK	3J1-KK	AZ POS POT CW	.002	22	
302	1J4-LL	3J1-LL	AZ POS POT WIPER	.002	22	
303	1J4-MM	3J1-MM	AZ POS POT CCW	.002	22	NO CONNECTION
304	1J4-NN	3J1-NN	SPARE		22	
305	1J4-PP	3J1-PP	SAFETY GROUND		22	
306	4J1-G					
307	4J2-A	1J3-Y	SPARE		20	
308	4J2-B	1J3-Z	SPARE		22	

MIL-HDBK-258 (AS)

TABLE II. IRDS interwiring list. - Continued

WIRE NO.	FROM CONNECTOR PIN	TO CONNECTOR PIN	FUNCTION	CURR AMP	WIRE SIZE	REMARKS
309	4J2-C	1J3-G	FOCUS HI	.002	22	SHIELDED-TWISTED PAIR ±10 VDC ANALOG
310	4J2-D	1J3-H	FOCUS LD	.002	22	
311	4J2-E	1J3-F	SHIELD			SHIELD TERMINATED AT 4J2-E AND 1J3-F
312	4J2-F	4J3-M	COOLING	.06	22	±18 VDC SWITCHED
313	4J2-G	1J3-BB	+28 VDC STANDBY	.5	22	
314	4J2-H	1J3-AA	RETICLE INT	.1	22	+28 VDC ANALOG
315	4J2-J	1J3-ZH	FIELD OF VIEW NEAR	.13	22	TWISTED PAIR +28 VDC SWITCHED
316	4J2-K	1J3-ZH	FIELD OF VIEW RETURN	.13	22	
317	4J2-L	4J3-V	POLARITY SELECT	.01	22	TWISTED PAIR -5 VDC SWITCHED
318	4J2-M	1J3-W	POLARITY RETURN	.01	22	
319	4J2-N	1J3-X	SHIELD FOR WIRES NO. 320-322, 323-325			SHIELD TERMINATED AT 4J2-N AND 1J3-X
320	4J2-P	1J3-S	VIDEO LEVEL POT CW	.002	22	SHIELDED-TWISTED TRIPLET 5 VDC ANALOG SHIELD TO NO. 319
321	4J2-R	1J3-T	VIDEO LEVEL POT WIPER	.001	22	
322	4J2-S	1J3-U	VIDEO LEVEL POT CCW	.002	22	

TABLE II. IRDS interwiring list. - Continued

WIRE NO.	FROM CONNECTOR PIN	TO CONNECTOR PIN	FUNCTION	CURR AMP	WIRE SIZE	REMARKS
323	4J2-T	1J3-N	VIDEO GAIN POT CW	.002	22	SHIELDED TWISTED TRIPLLET 5 VDC ANALOG SHIELD TO NO. 319
324	4J2-U	1J3-P	VIDEO GAIN POT WIPER	.001	22	
325	4J2-V	1J3-R	VIDEO GAIN POT CCW	.002	22	
326	1J3-A					NO CONTACT
327	1J3-B					NO CONTACT
328	1J3-C					NO CONTACT
329	1J3-D					NO CONTACT
330	1J3-E					NO CONTACT
331	1J3-J					NO CONTACT
332	1J3-K					NO CONTACT
333	1J3-L					NO CONTACT
334	1J3-M					NO CONTACT
335	1J3-ZA	1J3-ZB	SYSTEM INTERLOCK	.13	24	28 VDC SWITCHED
336	1J3-ZC					NO CONTACT
337	1J3-ZD					NO CONTACT

MIL-HDBK-258 (AS)

TABLE II. IRDS interwiring list. - Continued

WIRE NO.	FROM CONNECTOR PIN	TO CONNECTOR PIN	FUNCTION	CURR AMP	WIRE SIZE	REMARKS
338	1J3-ZE					NO CONTACT
339	1J3-ZF		SPARE			NOT USED
340	1J3-ZG					NO CONTACT
341	1J3-ZH					NO CONTACT
342	1J3-ZI					NO CONTACT
343	1J3-ZJ		SPARE			NOT USED
344	1J3-ZK		SPARE			NOT USED
345	1J3-ZP		SPARE			NOT USED
346	1J3-ZQ		SPARE			NOT USED
347	1J3-ZR		SPARE			NOT USED
348	1J3-ZS		SPARE			NOT USED
349	1J3-ZT		SPARE			NOT USED
350						
351	1J3-ZU					INTERNALLY CONNECTED. DO NOT USE.
	1J3-ZV					INTERNALLY CONNECTED. DO NOT USE.

TABLE II. IRDS interwiring list. - Continued

WIRE NO.	FROM CONNECTOR PIN	TO CONNECTOR PIN	FUNCTION	CURR AMP	WIRE SIZE	REMARKS
353	1J3-ZW					INTERNALLY CONNECTED. DO NOT USE.
354	1J3-ZX					INTERNALLY CONNECTED. DO NOT USE.
355	1J3-ZY					INTERNALLY CONNECTED. DO NOT USE.
356	1J3-ZZ		SPARE			NOT USED
357	1J3-CC		SPARE			NOT USED
358	1J3-DD		SPARE			NOT USED
359	1J3-EE		SPARE			NOT USED
360	1J3-FF		SPARE			NOT USED
361	1J3-GG					NO CONTACT
362	1J3-HH					NO CONTACT
363	1J3-JJ					NO CONTACT
364	1J3-KK					NO CONTACT
365	1J3-LL					NO CONTACT
366	1J3-MM					NO CONTACT

MIL-HDBK-258 (AS)

TABLE II. IRDS interwiring list. - Continued

WIRE NO.	FROM CONNECTOR PIN	TO CONNECTOR PIN	FUNCTION	CURR AMP	WIRE SIZE	REMARKS
367	1J3-PP		SPARE			NOT USED
368	3J3-1					NOT USED
369	3J3-2					NOT USED
370	3J3-3					NOT USED
371	3J3-4					NOT USED
372	3J3-5					NOT USED
373	3J3-6					NOT USED
374	3J3-7					NOT USED
375	3J3-8					NOT USED
376	3J3-9					NOT USED
377	3J3-10					NOT USED
378	3J3-11					NOT USED
379	3J3-11					NOT USED
380	3J3-13					NOT USED
381	3J3-14					NOT USED

TABLE II. IRDS interwiring list. - Continued

WIRE NO.	FROM CONNECTOR PIN	TO CONNECTOR PIN	FUNCTION	CURR AMP	WIRE SIZE	REMARKS
382	3J3-15					NOT USED
383	3J3-16					NOT USED
384	3J3-17					NOT USED
385	3J3-18					NOT USED
386	3J3-19					NOT USED
387	3J3-20					NOT USED
388	3J3-21					NOT USED
389	3J3-22					NOT USED
390	3J3-23					NOT USED
391	3J3-24					NOT USED
392	3J3-25					INTERNALLY CONNECTED. DO NOT USE.
393	3J3-26					INTERNALLY CONNECTED. DO NOT USE.
394	3J3-27					INTERNALLY CONNECTED. DO NOT USE.

MIL-HDBK-258(AS)

TABLE II. IRDS interwiring list. - Continued

WIRE NO.	FROM CONNECTOR PIN	TO CONNECTOR PIN	FUNCTION	CURR AMP	WIRE SIZE	REMARKS
395	3J3-28					NOT USED
396	3J3-29	3J3-30	PILOT FWD		22	+5 VDC SWITCHED
397						
398	3J3-31				22	NOT USED
399	3J3-32	AIRCRAFT SYNCHRO REFERENCE SOURCE. SEE PARA-GRAPH 5.3.3.	26 VAC 400 HZ HI	.14	22	SHIELDED-TWISTED PAIR
400	3J3-33		26 VAC 400 HZ LO	.14		SHIELD TERMINATED AT 3J2-34 AND 26 VAC REFERENCE SOURCE
401	3J3-34		SHIELD			
402	3J3-35		DATA BIT 00	.04	22	SHIELDED TWISTED
403	3J3-36	AIRCRAFT DATA PROCESSING SYSTEM SEE PARA-GRAPH 5.3.1.	RETURN	.04	22	PAIRS 5 VDC SWITCHED INTO 130Ω AC,
404	3J3-37		DATA BIT 01	.04	22	2KΩ DC LOADS
405	3J3-38		RETURN	.04	22	SHIELDS TO NO. 430
406	3J3-39					NOT USED

TABLE II. IRDS interwiring list. - Continued

WIRE NO.	FROM CONNECTOR PIN	TO CONNECTOR PIN	FUNCTION	CURR AMP	WIRE SIZE	REMARKS
407	3J3-40	AIRCRAFT DATA PROCESSING SYSTEM. SEE PARAGRAPH 5.3.1.	DATA BIT 02	.04	22	SHIELDED-TWISTED PAIRS +5 VDC SWITCHED INTO 130Ω AC, 2KΩ DC LOADS SHIELDS TO WIRE NO. 430
408	3J3-41		RETURN	.04	22	
409	3J3-42		DATA BIT 03	.04	22	
410	3J3-43		RETURN	.04	22	
411	3J3-44		DATA BIT 04	.04	22	
412	3J3-45		RETURN	.04	22	
413	3J3-46		DATA BIT 05	.04	22	
414	3J3-47		RETURN	.04	22	
415	3J3-48		DATA BIT 06	.04	22	
416	3J3-49		RETURN	.04	22	
417	3J3-50		DATA BIT 07	.04	22	
418	3J3-51		RETURN	.04	22	
419	3J3-52		DATA BIT 08	.04	22	
420	3J3-53		RETURN	.04	22	
421	3J3-54		DATA BIT 09	.04	22	
422	3J3-55	RETURN	.04	22		

MIL-HDBK-258 (AS)

TABLE II. IRDS interwiring list. - Continued

WIRE NO.	FROM CONNECTOR PIN	TO CONNECTOR PIN	FUNCTION	CURR AMP	WIRE SIZE	REMARKS		
423	3J3-56	AIRCRAFT DATA PROCESSING SYSTEM SEE PARAGRAPH 5.3.1.	DATA BIT 10	.04	22	NOT USED		
424	3J3-57		RETURN	.04	22			
425	3J3-58		DATA BIT 11	RETURN	.04		22	
426	3J3-59				.04		22	
427	3J3-60		OUTPUT ACKNOWLEDGE	RETURN	.04		22	
428	3J3-61				.04		22	
429	3J3-62				.04		22	
430	3J3-63		AIRCRAFT DATA PROCESSING SYSTEM SEE PARAGRAPH 5.3.2.	SHIELD				SHIELD TERMINATED AT 3J3-63 AND DATA PROCESSING SYSTEM CONNECTOR
431	3J3-64			CPTR TRK	.002		22	SHIELDED TWISTED PAIR
432	3J3-65			RETURN	.002		22	+5 VDC SWITCHED
433	3J3-66	SHIELD					SHIELD TERMINATED AT 3J3-66 AND DATA PROCESSING SYSTEM CONNECTOR	

TABLE II. IRDS interwiring list. - Continued

WIRE NO.	FROM CONNECTOR PIN	TO CONNECTOR PIN	FUNCTION	CURR AMP	WIRE SIZE	REMARKS
434	3J3-67	AIRCRAFT DATA PRO-CESSING SYSTEM. SEE PARA-GRAPH 5.3.3.	AZ CX S1		22	SHIELDED TWISTED TRIPLETS 11.8 VRMS SHIELD TO NO. 440 400 HZ ANALOG INTO 500Ω
435	3J3-68		AZ CX S2		22	
436	3J3-69		AZ CX S3		22	
437	3J3-70		EL CX S1		22	
438	3J3-71		EL CX S2		22	
439	3J3-72		EL CX S3		22	
440	3J3-73			SHIELD FOR WIRES NO. 434-436 AND 437-439		
441	3J3-74	AIRCRAFT DATA PRO-CESSING SYSTEM. SEE PARA-GRAPH 5.3.2.	MAN TRACK HI	.002	22	SHIELDED TWISTED PAIR +5 VDC SWITCHED
442	3J3-75		MAN TRACK LO		22	
443	3J3-76		SHIELD			
444	3J3-77					INTERNALLY CONNECTED. DO NOT USE.
445	3J3-78					INTERNALLY CONNECTED. DO NOT USE.

TABLE II. IRDS interwiring list. - Continued

WIRE NO.	FROM CONNECTOR PIN	TO CONNECTOR PIN	FUNCTION	CURR AMP	WIRE SIZE	REMARKS
446	3J3-79					INTERNALLY CONNECTED. DO NOT USE.
447	3J3-80					INTERNALLY CONNECTED. DO NOT USE.
448	3J3-81					INTERNALLY CONNECTED. DO NOT USE.
449	3J3-82					INTERNALLY CONNECTED. DO NOT USE.
450	3J3-83					INTERNALLY CONNECTED. DO NOT USE.
451	3J3-84					INTERNALLY CONNECTED. DO NOT USE.
452	3J3-85					INTERNALLY CONNECTED. DO NOT USE.

TABLE II. IRDS interwiring list. - Continued

WIRE NO.	FROM CONNECTOR PIN	TO CONNECTOR PIN	FUNCTION	CURR AMP	WIRE SIZE	REMARKS
453	2J1-A	AIRCRAFT POWER SYSTEM	SYS PWR 115 VAC 400 HZ PH A	5.0 max	20	TWISTED TRIPLET 108-118 VRMS (LINE TO NEUTRAL)
454	2J1-B	AIRCRAFT POWER SYSTEM	SYS PWR 115 VAC 400 HZ PH B	5.0 max	20	
455	2J1-C	AIRCRAFT POWER SYSTEM	SYS PWR 115 VAC 400 HZ PH C	5.0 max	20	
456	2J1-D	AIRFRAME GROUND	AC RETURN	1.0	20	
457	2J1-E	AIRCRAFT POWER SYSTEM	+28 VDC SUPPLY	5.0 max	20	24-28.5 VDC
458	2J1-F	AIRFRAME GROUND	+28 VDC RETURN	5.0 max	20	
459	2J1-G	AIRFRAME GROUND	SAFETY GROUND			
460	2J1-H					NO CONTACT

MIL-HDBK-258 (AS)

TABLE II. IRDS interwiring list. - Continued

WIRE NO.	FROM CONNECTOR PIN	TO CONNECTOR PIN	FUNCTION	CURR AMP	WIRE SIZE	REMARKS
461	2J1-J	AIRCRAFT POWER SYSTEM	HEATER 115 VAC 400 HZ PH A	5.0 max	20	TWISTED TRIPLET 108-118 VRMS (LINE TO NEUTRAL)
462	2J1-K	AIRCRAFT POWER SYSTEM	HEATER 115 VAC 400 HZ PH B	5.0 max	20	
463	2J1-L	AIRCRAFT POWER SYSTEM	HEATER 115 VAC 400 HZ PH C	5.0 max	20	
464	2J1-M	AIRFRAME GROUND	AC RETURN	0	20	
465	2J1-N	AIRCRAFT 18 VDC	+18 VDC HI	1.3 max	20	18 ±1 VDC
466	2J1-P	AIRFRAME GROUND	+18 VDC RETURN	1.3 max	20	
467	2J1-R					NO CONTACT
468	2J1-S					NO CONTACT
469	2J7	6J2	VIDEO OUT			75 OHM VIDEO TRIAX
470						
471						

MIL-HDBK-258 (AS)

TABLE II. IRDS interwiring list. - Continued

WIRE NO.	FROM CONNECTOR PIN	TO CONNECTOR PIN	FUNCTION	CURR AMP	WIRE SIZE	REMARKS
472	2J4-A					NO CONTACT
473	2J4-B					NO CONTACT
474	2J4-C					NO CONTACT
475	2J4-G					NO CONTACT
476	2J4-H					NO CONTACT
477	2J4-EE					NO CONTACT
478	2J4-FF					NO CONTACT
479	3J1-ZX		GROUND LUG CHASSIS			NOT USED
480	3J1-AA					NOT USED
481	6J1-D					NOT USED

MIL-HDBK-258(AS)

**TABLE III. Angle rate codes.**

Angle Rate (degrees/second)	Sign 11	MSB 10	Bit									LSB 0
			9	8	7	6	5	4	3	2	1	
+60.0	1	1	1	1	1	1	1	1	1	1	1	1
+30.00000	1	1	0	0	0	0	0	0	0	0	0	0
+15.0	1	0	1	0	0	0	0	0	0	0	0	0
+7.5	1	0	0	1	0	0	0	0	0	0	0	0
+3.75	1	0	0	0	1	0	0	0	0	0	0	0
+1.875	1	0	0	0	0	1	0	0	0	0	0	0
+0.938	1	0	0	0	0	0	1	0	0	0	0	0
+0.469	1	0	0	0	0	0	0	1	0	0	0	0
+0.234	1	0	0	0	0	0	0	0	1	0	0	0
+0.117	1	0	0	0	0	0	0	0	0	1	0	0
+0.058	1	0	0	0	0	0	0	0	0	0	1	0
+0.029	1	0	0	0	0	0	0	0	0	0	0	1
+0.0000000	1	0	0	0	0	0	0	0	0	0	0	0
-0.0000000	0	0	0	0	0	0	0	0	0	0	0	0
-0.029	0	0	0	0	0	0	0	0	0	0	0	1
-0.058	0	0	0	0	0	0	0	0	0	0	1	0
-0.117	0	0	0	0	0	0	0	0	0	1	0	0
-0.234	0	0	0	0	0	0	0	0	1	0	0	0
-0.469	0	0	0	0	0	0	0	1	0	0	0	0
-0.938	0	0	0	0	0	0	1	0	0	0	0	0
-1.875	0	0	0	0	0	1	0	0	0	0	0	0

TABLE III Angle rate codes. - Continued

Angle Rate (degrees/second)	Sign 11	MSB 10	Bit									LSB 0
			9	8	7	6	5	4	3	2	1	
-3.75	0	0	0	0	1	0	0	0	0	0	0	0
-7.5	0	0	0	1	0	0	0	0	0	0	0	0
-15.0	0	0	1	0	0	0	0	0	0	0	0	0
-30.0	0	1	0	0	0	0	0	0	0	0	0	0
-60.0	0	1	1	1	1	1	1	1	1	1	1	1

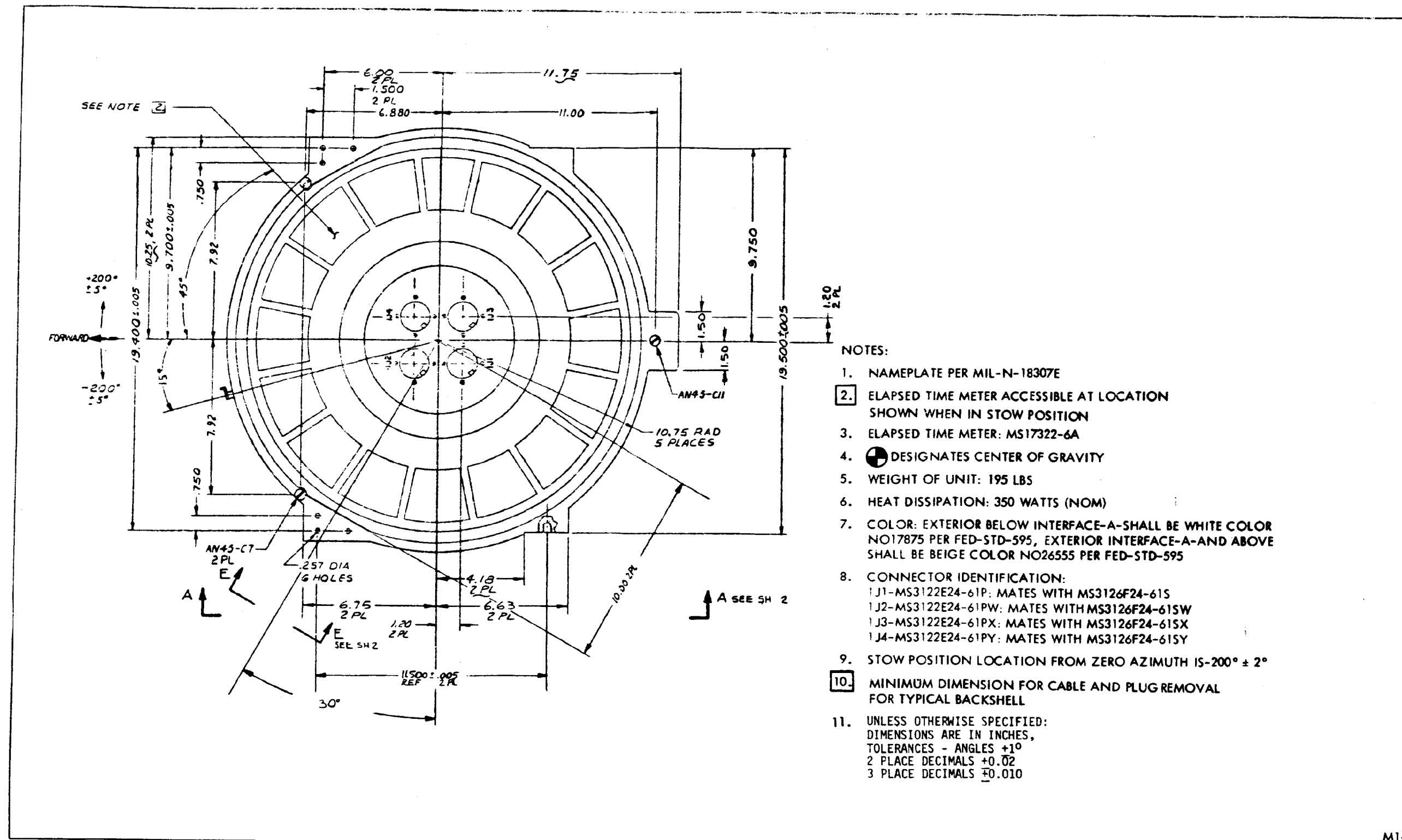
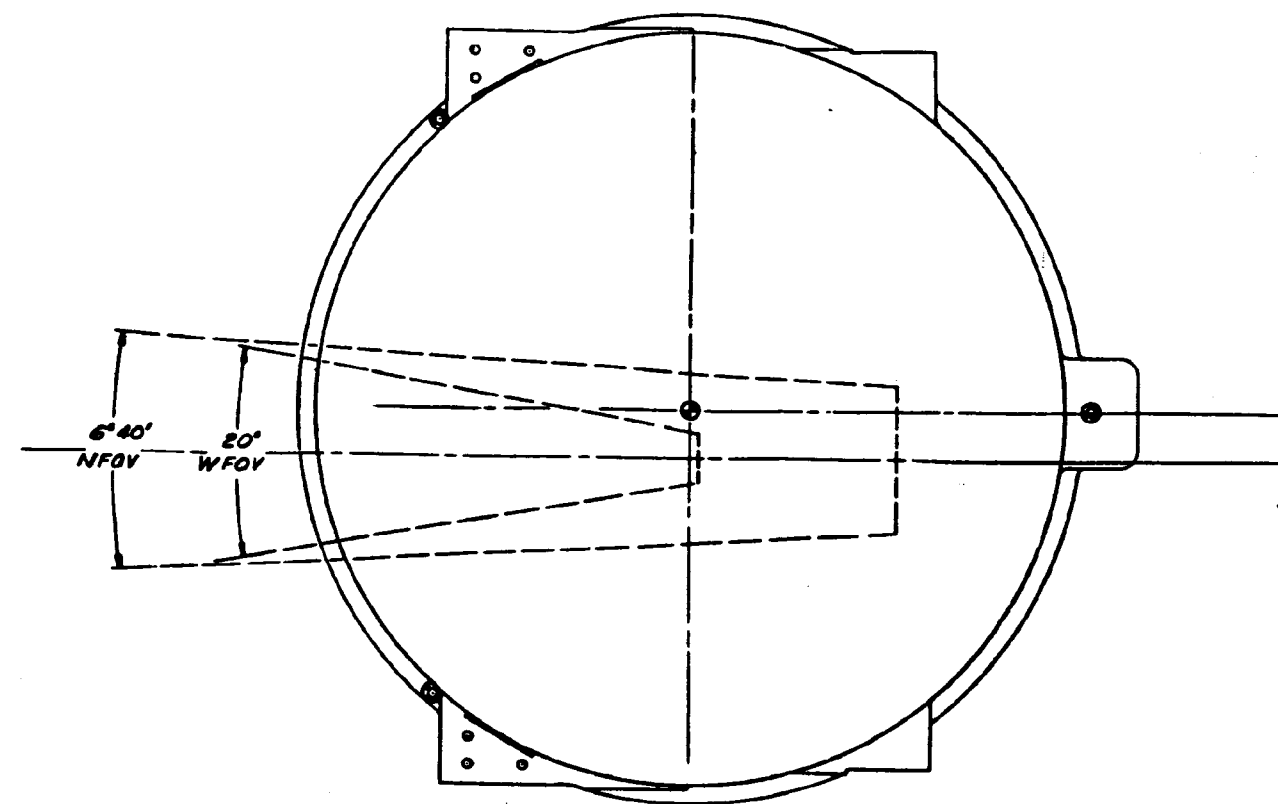

FIGURE 1. Receiver converter, outline drawing. (sheet 1 of 5)





VIEW B-B SH 2

M1-3

FIGURE 1. Receiver converter, outline drawing. (sheet 3 of 5)

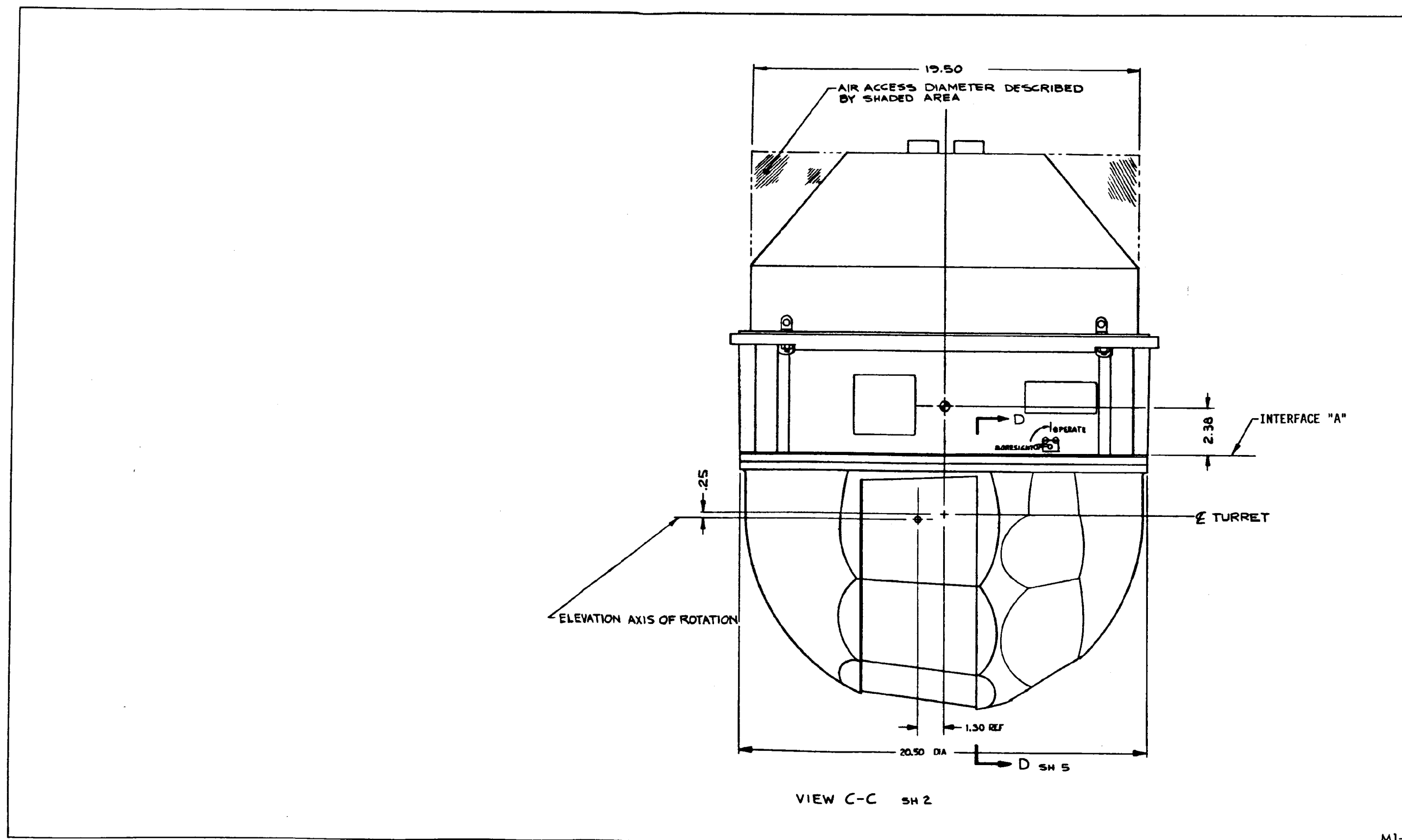

FIGURE 1. Receiver converter, outline drawing. (sheet 4 of 5)

M1-4

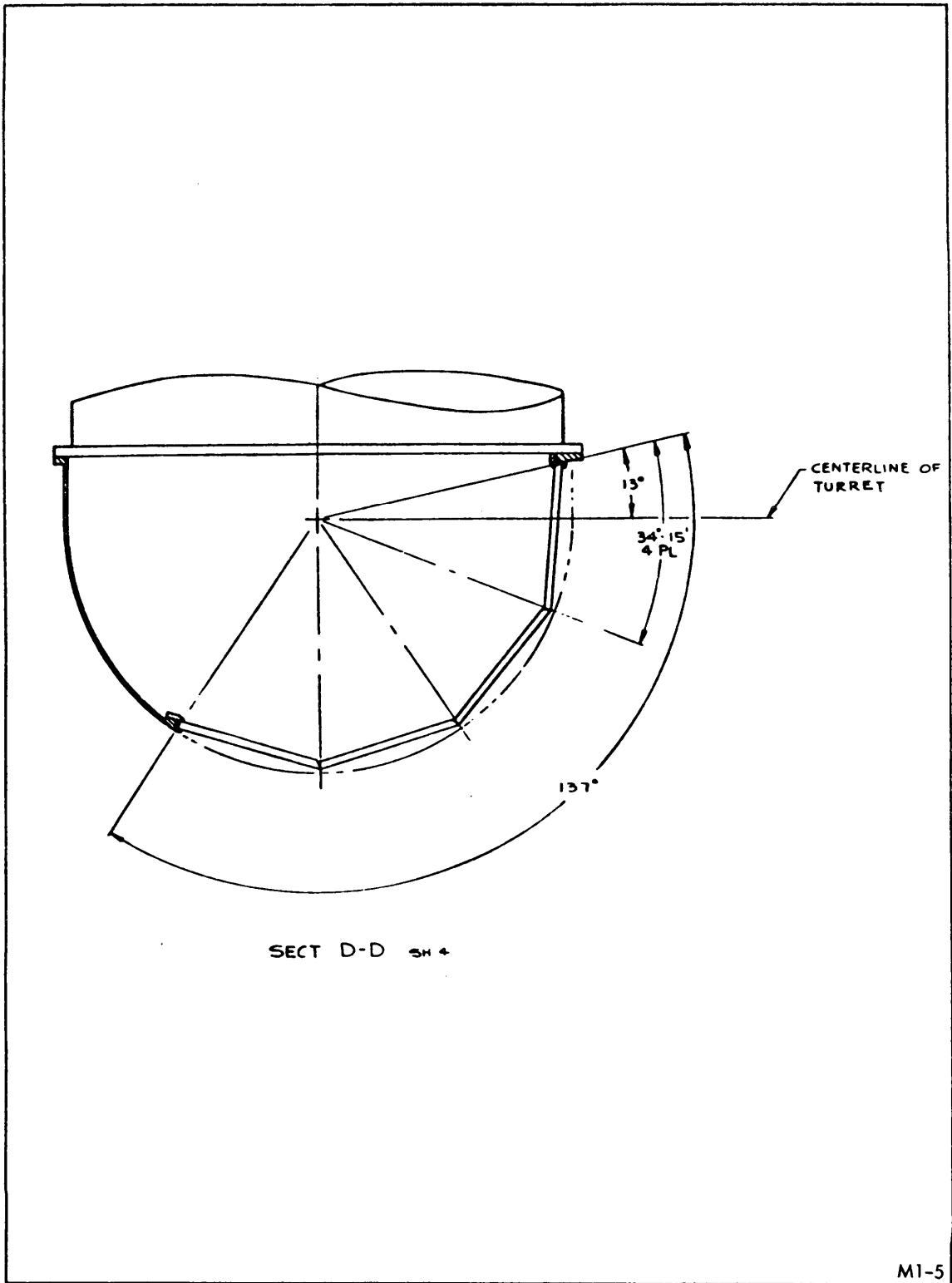

FIGURE 1. Receiver converter, outline drawing. (sheet 5 of 5)

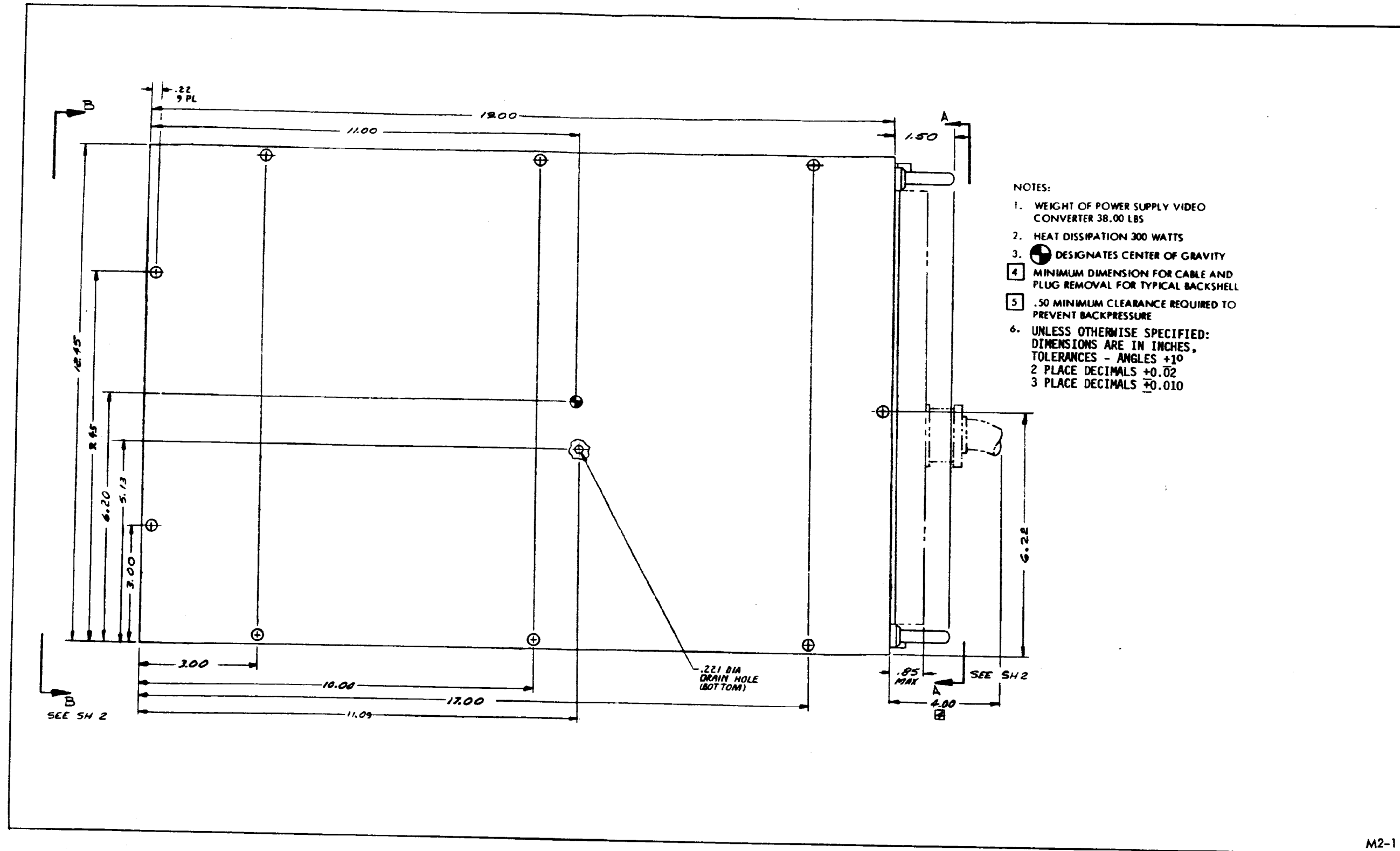

FIGURE 2. Power supply/video converter, outline drawing. (sheet 1 of 2)

M2-1

17  
 o/s

5/1

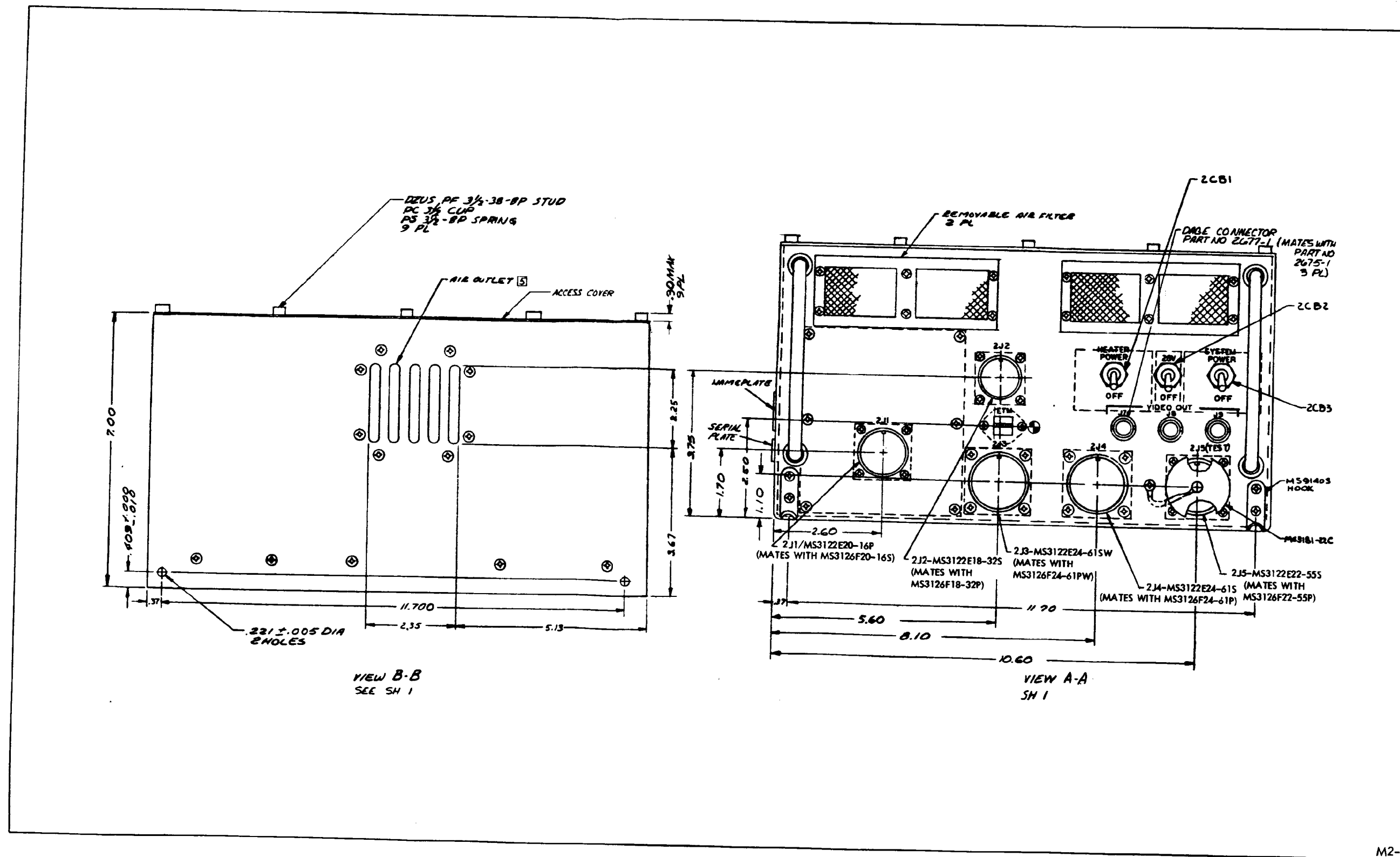
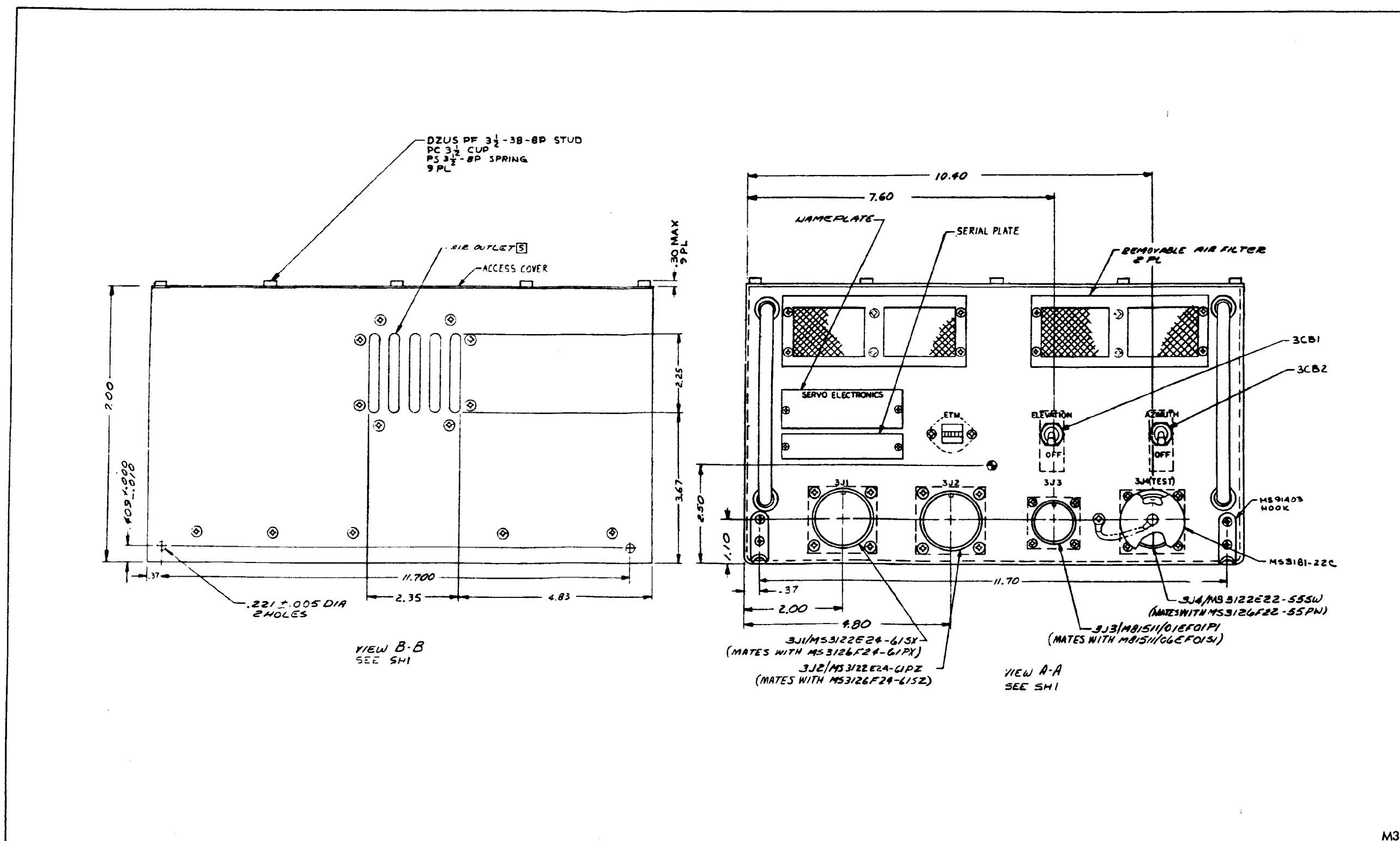

FIGURE 2. Power supply/video converter, outline drawing. (sheet 2 of 2)





M3-2

FIGURE 3. Control servomechanism, outline drawing. (sheet 2 of 2)

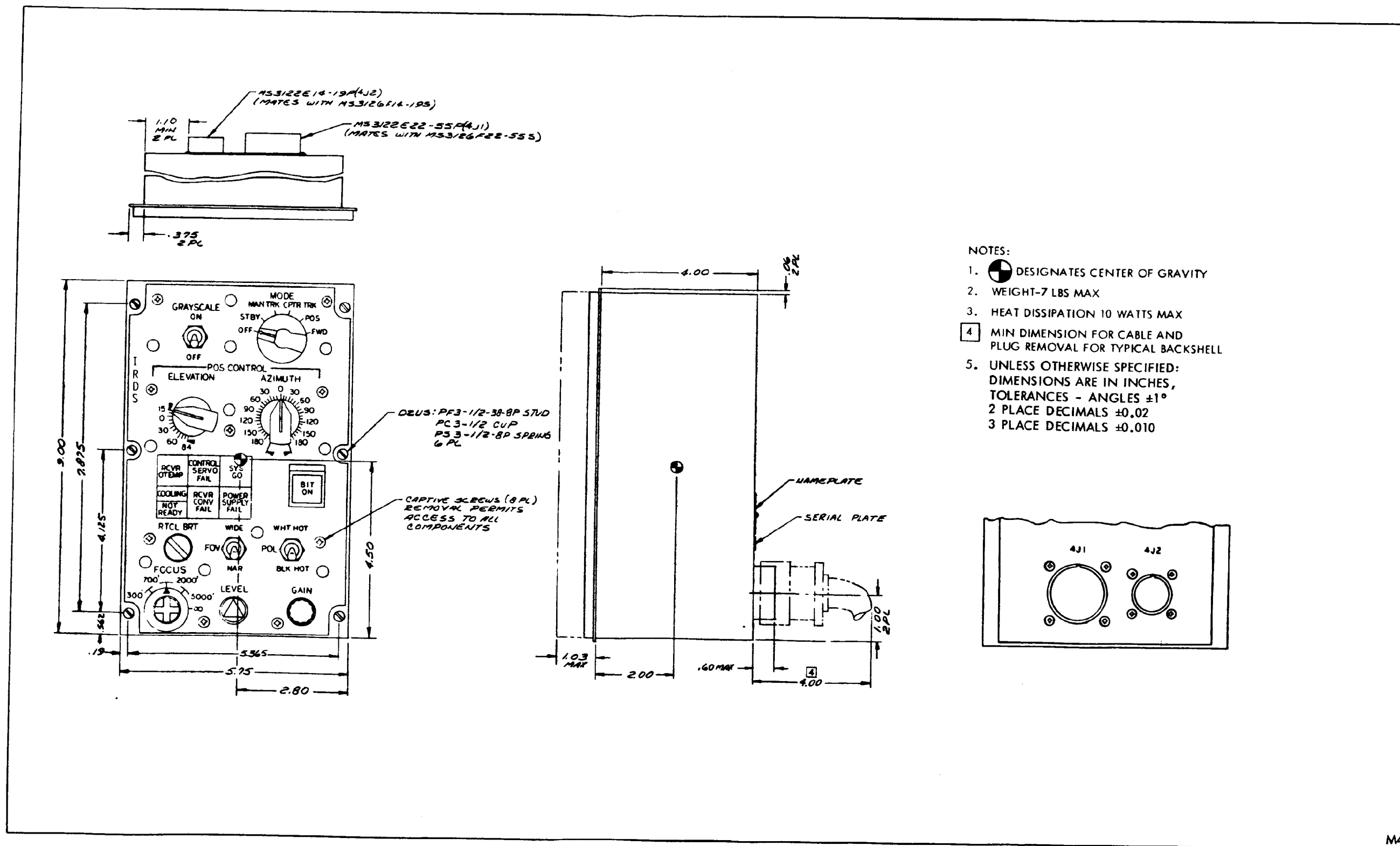
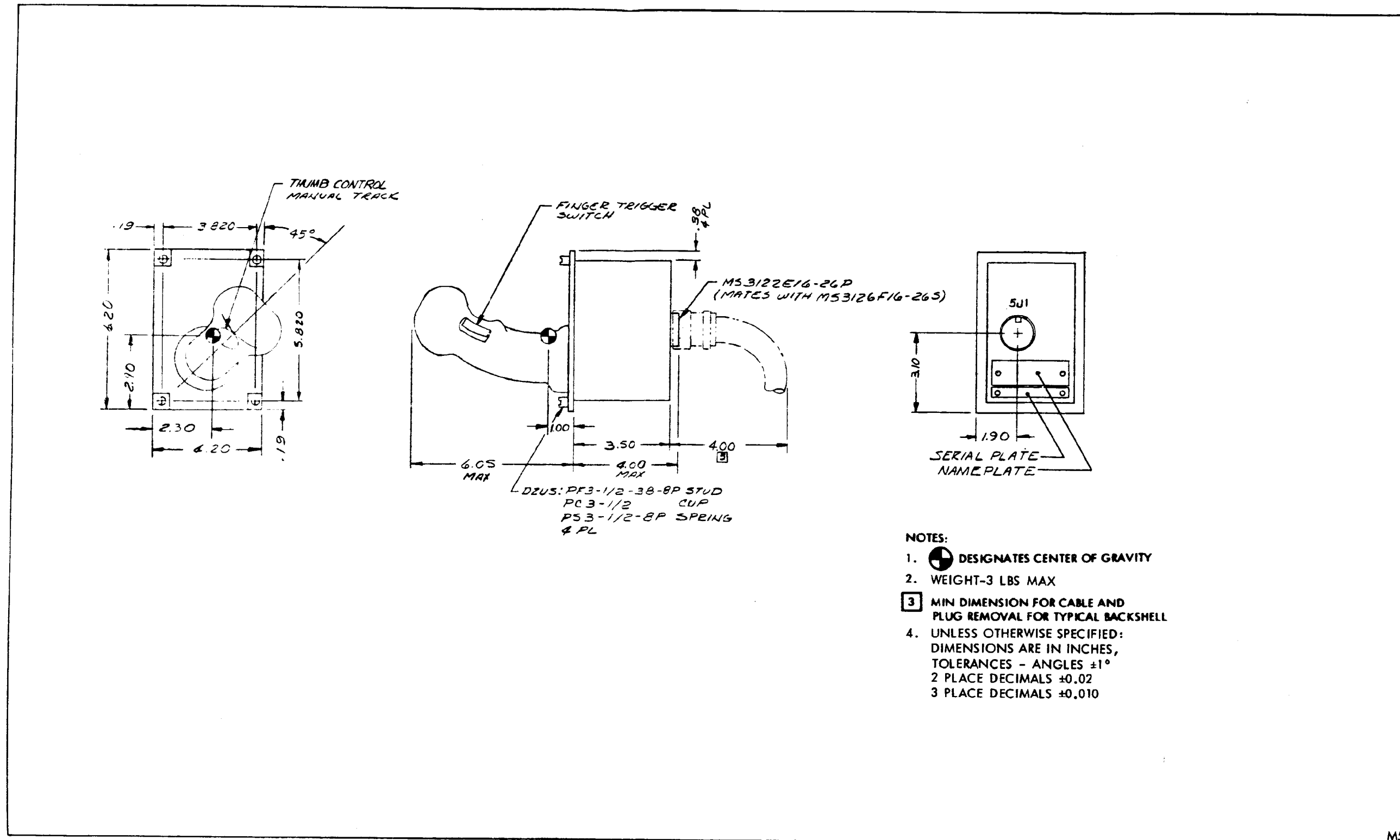

FIGURE 4. Control, detecting set, infrared, outline drawing.



M5

FIGURE 5. Control, sight, target, tracking, outline drawing.

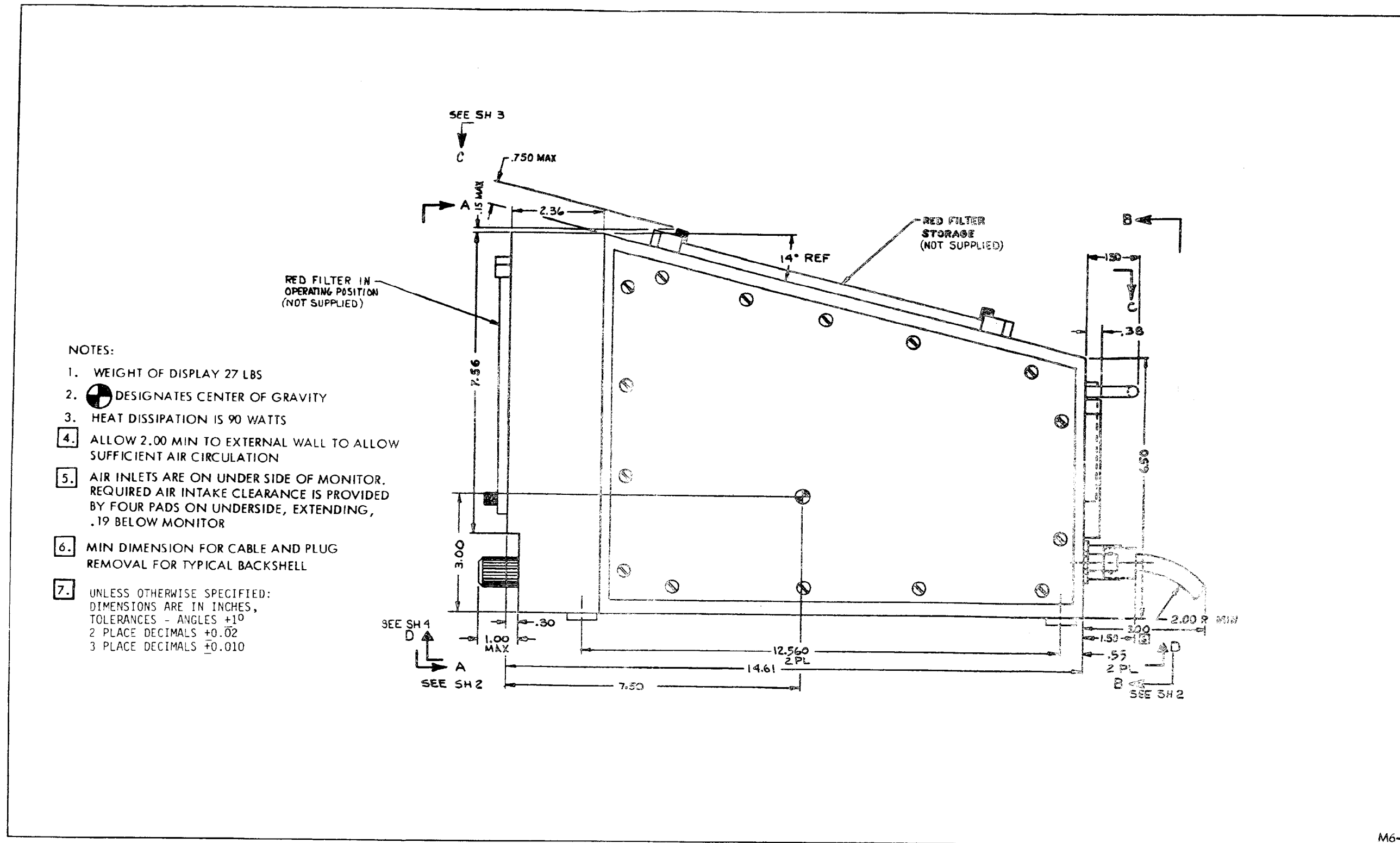

FIGURE 6. Indicator, video, outline drawing. (sheet 1 of 4)

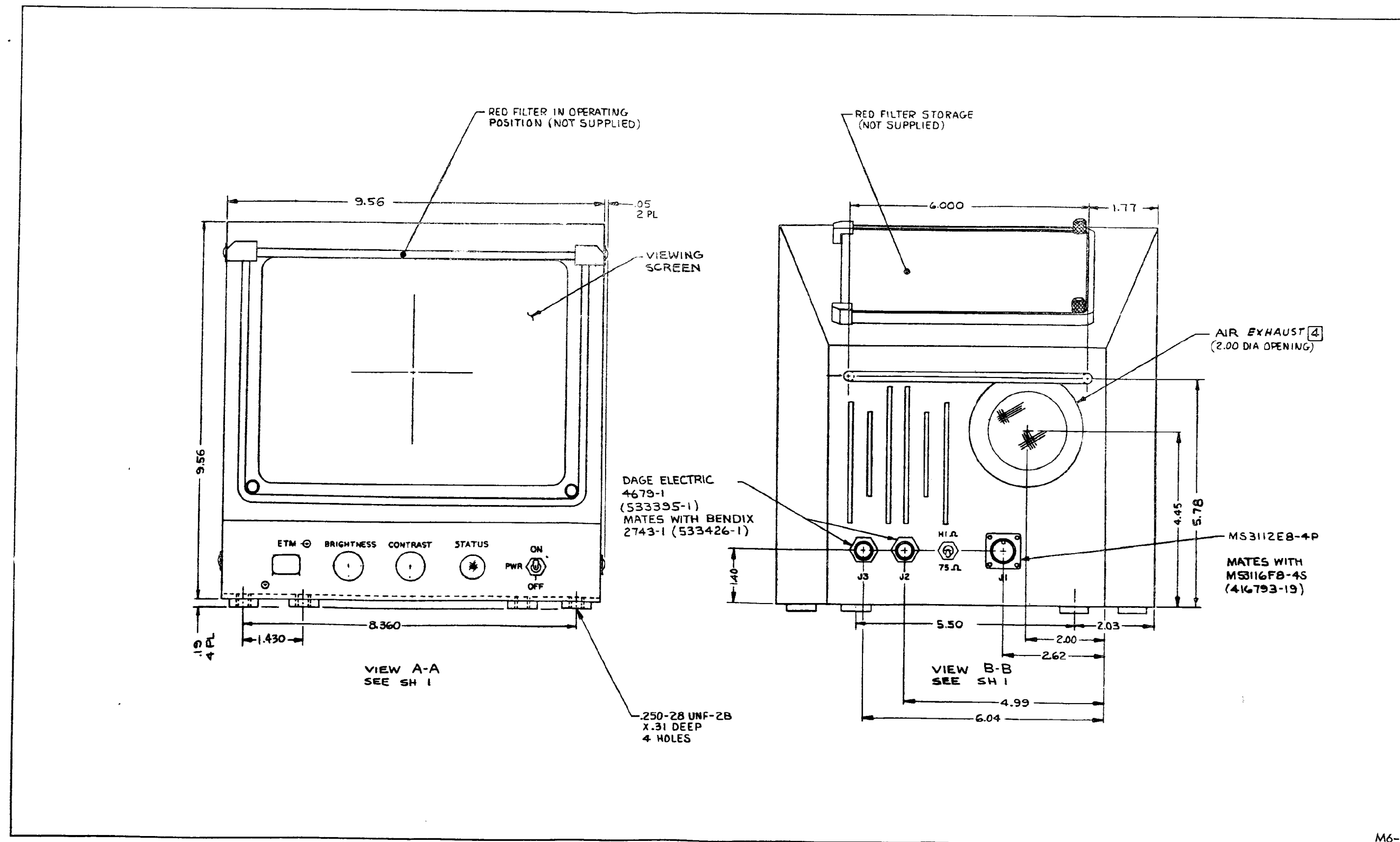
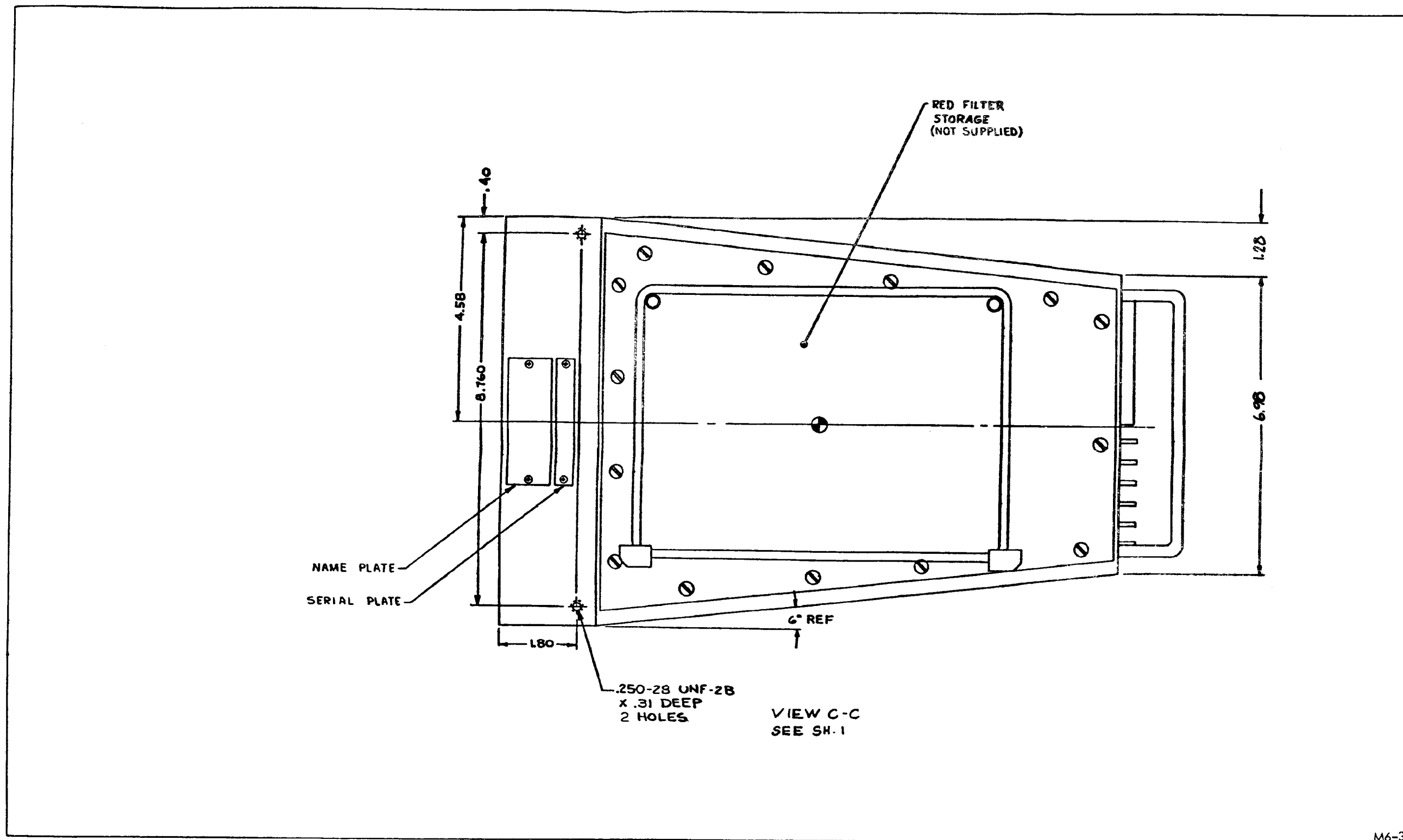

FIGURE 6. Indicator, video, outline drawing. (sheet 2 of 4)



M6-3

FIGURE 6. Indicator, video, outline drawing. (sheet 3 of 4)

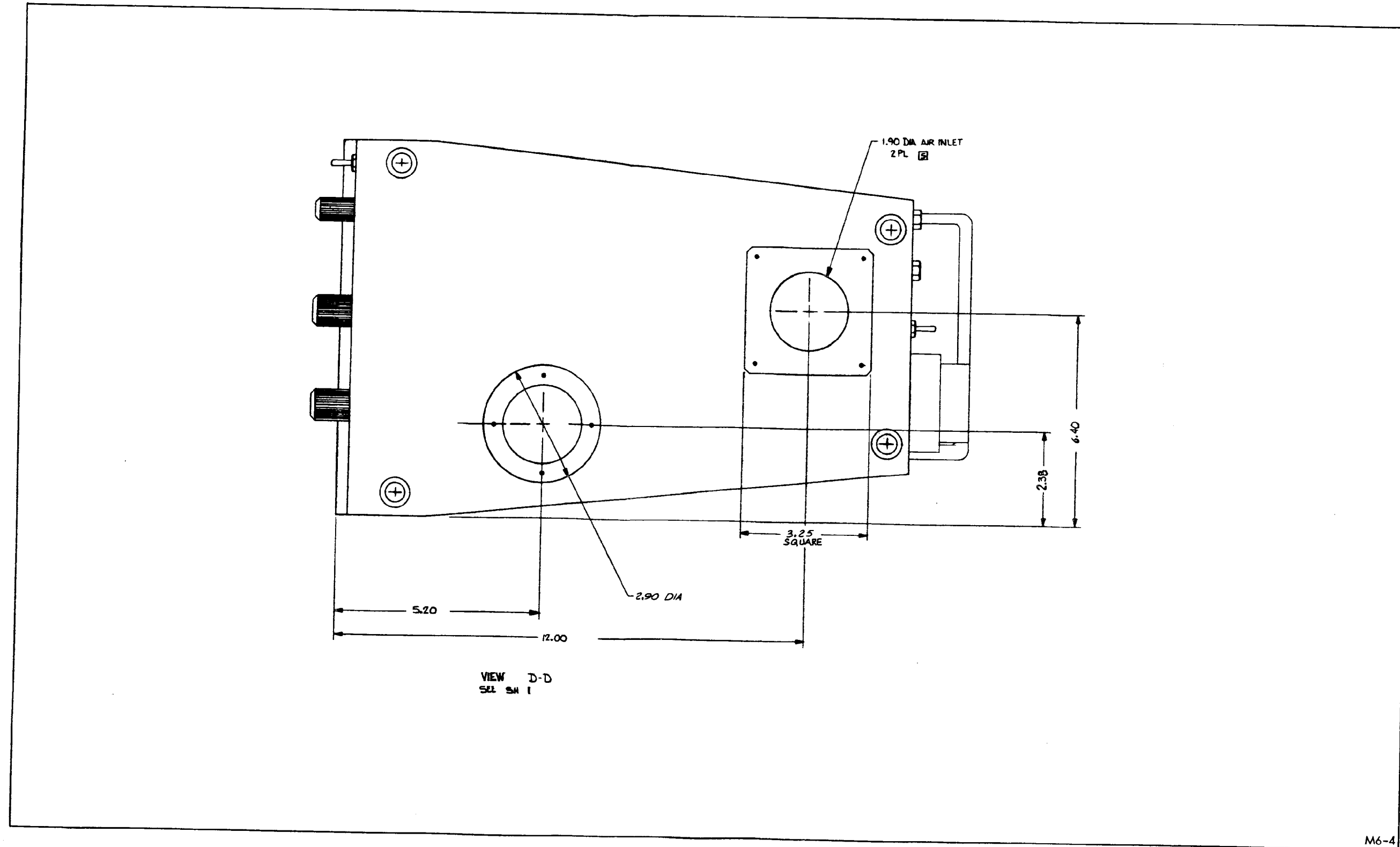

FIGURE 6. Indicator, video, outline drawing. (sheet 4 of 4)

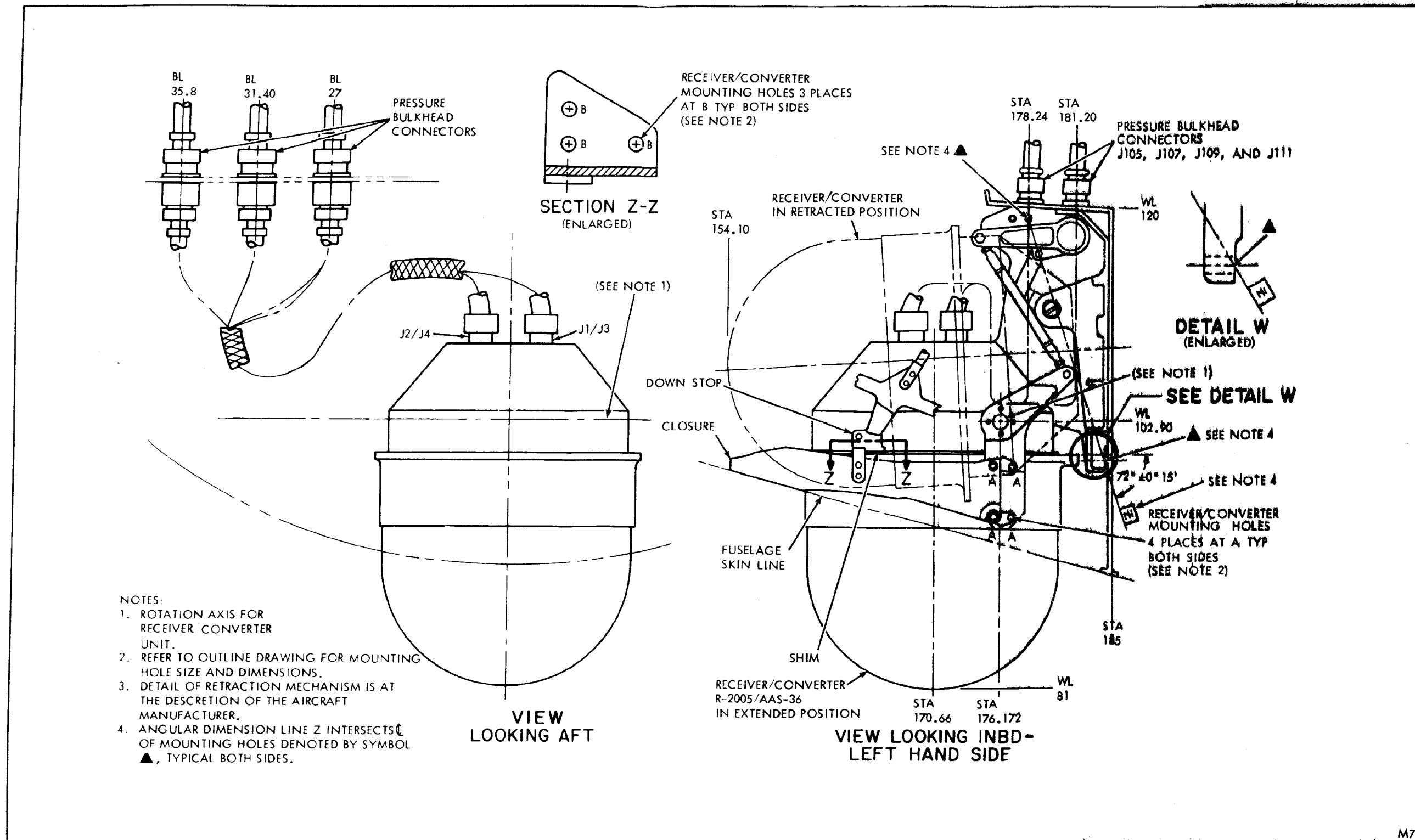

FIGURE 7. Receiver converter retractable turret installation (typical).

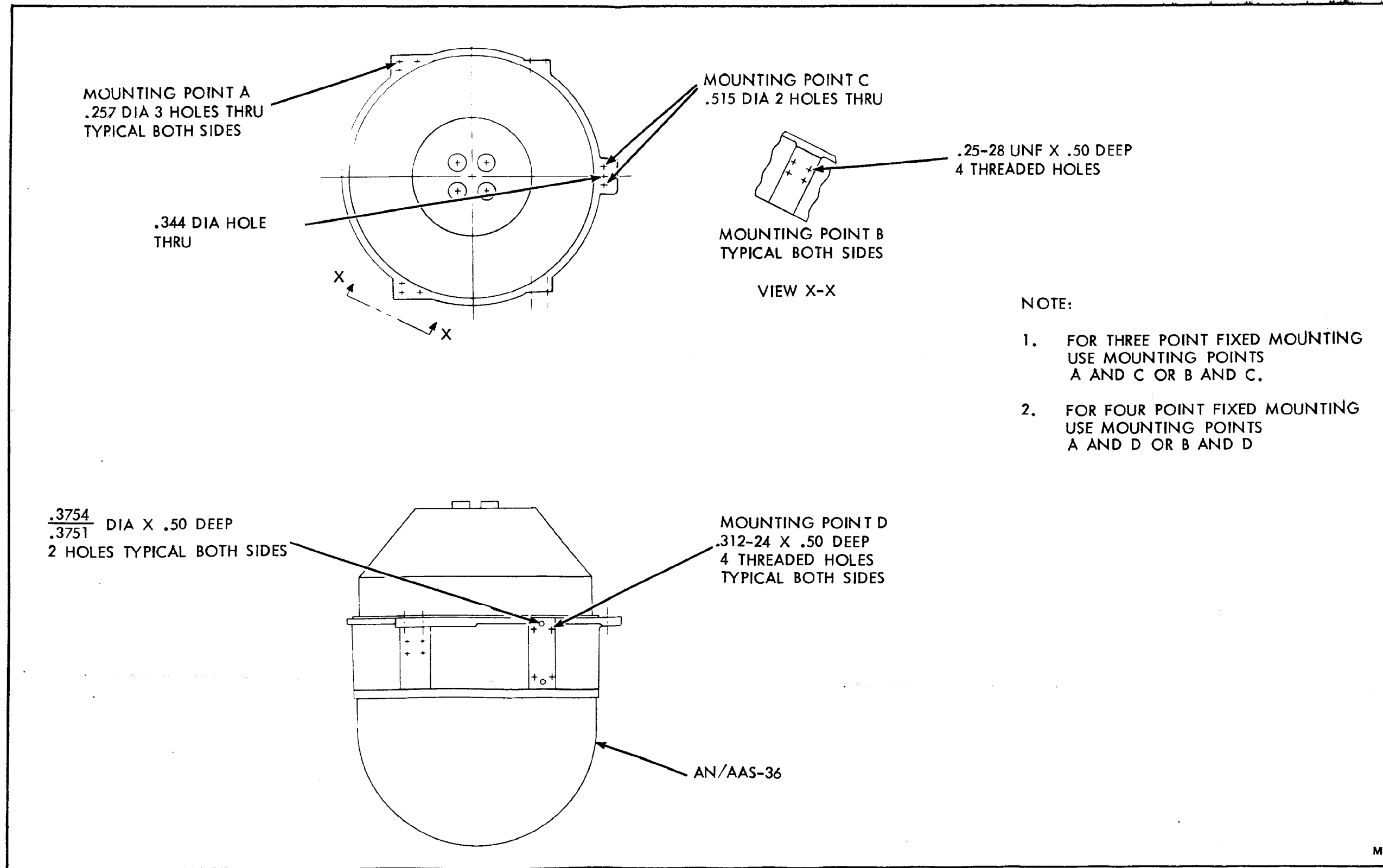

FIGURE 8. Receiver converter fixed turret installation (typical).

TABLE IV. Metric equivalents inches to millimeters.

Inch	MM	Inch	MM	Inch	MM
*****	*****	*****	*****	*****	*****
0.0010	0.025	1.9000	48.260	6.2000	157.480
0.0050	0.127	2.0000	50.800	6.2200	157.988
0.0100	0.254	2.0300	51.562	6.4000	162.560
0.0200	0.508	2.2500	57.150	6.5000	165.100
0.0500	1.270	2.3000	58.420	6.6300	168.402
0.0600	1.524	2.3500	59.690	6.7500	171.450
0.0900	2.286	2.3600	59.944	6.8800	171.752
0.1500	3.810	2.3800	60.452	6.9800	177.292
0.1900	4.810	2.5000	63.500	7.0000	177.800
0.2100	5.334	2.6000	66.040	7.5000	190.500
0.2200	5.588	2.6200	66.548	7.5600	192.024
0.2210	5.613	2.8000	71.120	7.6000	193.040
0.2500	6.350	2.9000	73.660	7.8750	200.025
0.2570	6.528	3.0000	76.200	7.9200	201.168
0.3000	7.620	3.1000	78.740	8.1000	205.740
0.3100	7.874	3.2500	82.550	8.3600	212.344
0.3120	7.925	3.4000	86.360	8.7600	222.504
0.3700	9.398	3.5000	88.900	9.0000	228.600
0.3750	9.525	3.6700	93.218	9.4500	240.030
0.3751	9.528	3.7500	95.250	9.5600	242.824
0.3754	9.535	3.8200	97.028	9.7000	246.380
0.3800	9.652	4.0000	101.600	9.7500	247.650
0.4000	10.160	4.1250	104.775	10.0000	254.000
0.4090	10.389	4.1800	106.172	10.2500	260.350
0.5000	12.700	4.2000	106.680	10.4000	264.160
0.5500	13.970	4.4500	113.030	10.6000	269.240
0.5620	14.275	4.5000	114.300	10.7500	273.050
0.6000	15.240	4.5800	116.332	11.0000	279.400
0.6250	15.875	4.7500	120.650	11.0900	281.686
0.6900	17.526	4.8000	121.920	11.5000	292.100
0.7500	19.050	4.8300	122.682	11.7000	297.180
0.8500	21.590	4.9900	126.746	11.7500	298.450
1.0000	25.400	5.1300	130.302	12.0000	304.800
1.0300	26.162	5.2000	132.080	12.4500	316.230
1.1000	27.940	5.3650	136.271	12.5600	319.024
1.2000	30.480	5.5000	139.700	14.6100	371.094
1.2800	32.512	5.6000	142.240	15.1200	384.048
1.3000	33.020	5.6400	143.256	17.0000	431.800
1.3300	33.782	5.7500	146.050	19.0000	482.600
1.4000	35.560	5.7800	146.812	19.4000	492.760
1.4300	36.322	5.8200	147.828	19.5000	495.300
1.5000	38.100	6.0000	152.400	20.0000	508.000
1.7000	43.180	6.0400	153.416	20.5000	520.700
1.7700	44.958	6.0500	153.670	28.1000	713.740
1.8000	45.720				

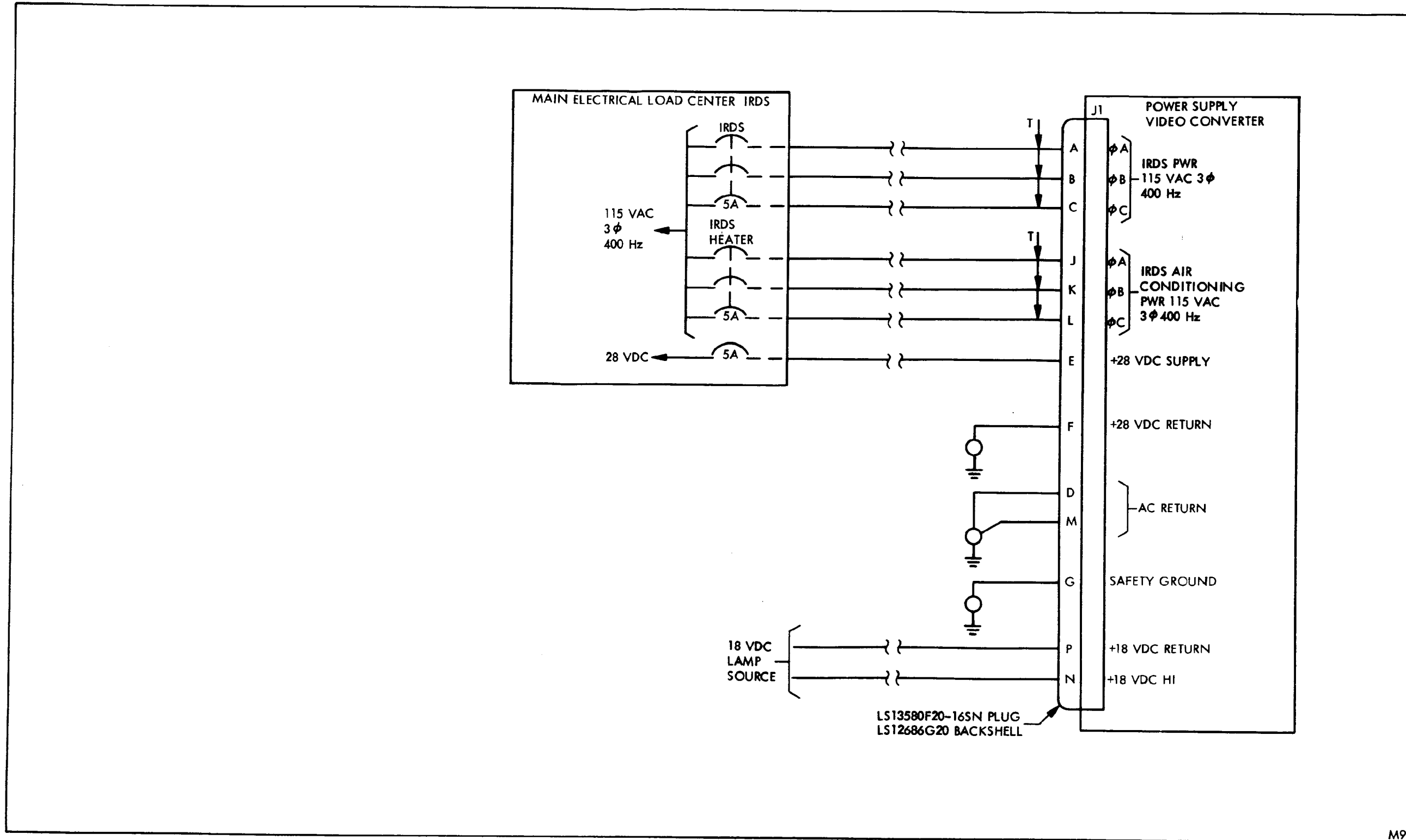
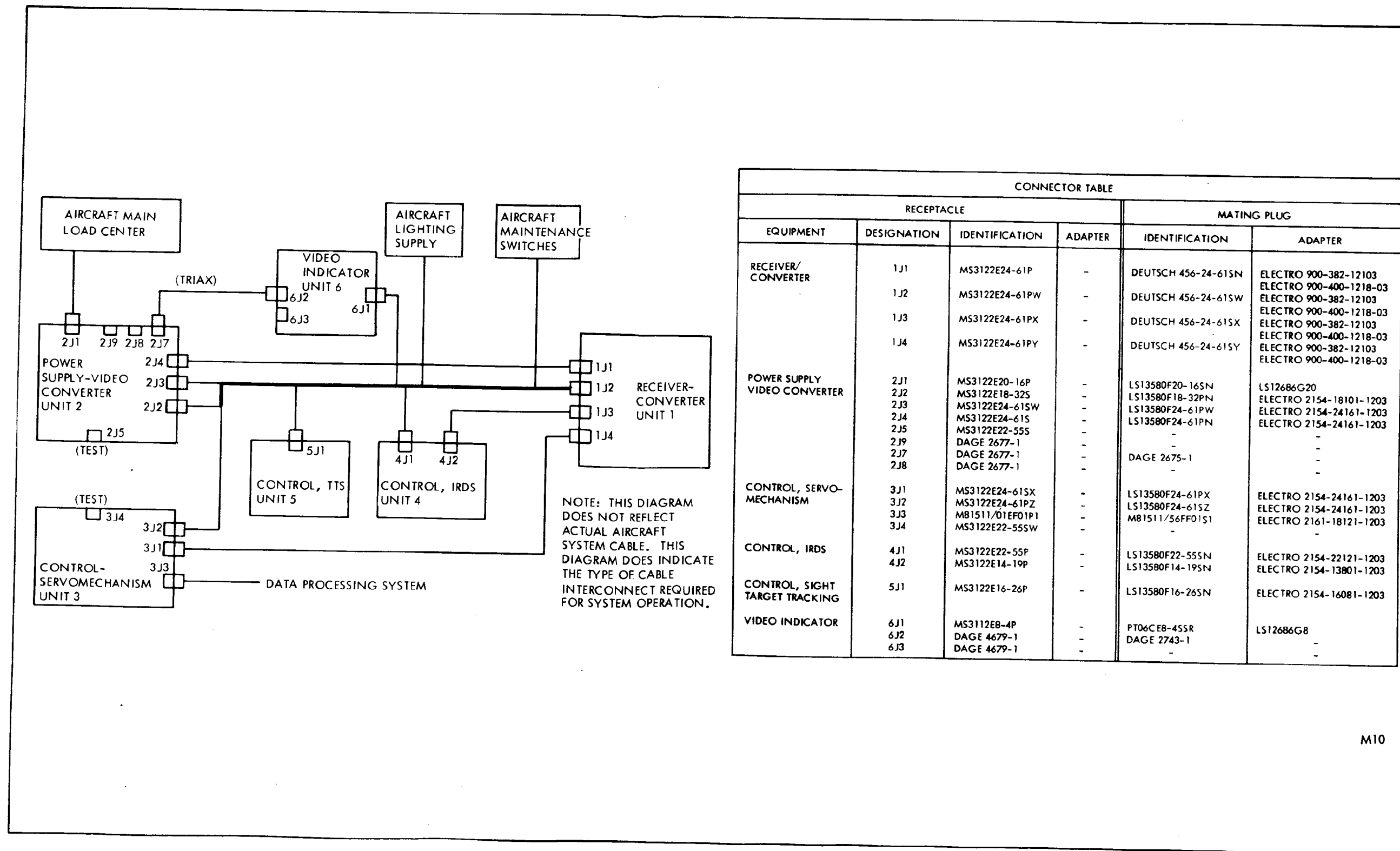

FIGURE 9. IRDS aircraft primary power interface.



CONNECTOR TABLE					
EQUIPMENT	RECEPTACLE			MATING PLUG	
	DESIGNATION	IDENTIFICATION	ADAPTER	IDENTIFICATION	ADAPTER
RECEIVER/ CONVERTER	1J1	MS3122E24-61P	-	DEUTSCH 456-24-61SN	ELECTRO 900-382-12103
	1J2	MS3122E24-61PW	-	DEUTSCH 456-24-61SW	ELECTRO 900-400-1218-03
	1J3	MS3122E24-61PX	-	DEUTSCH 456-24-61SX	ELECTRO 900-382-12103
	1J4	MS3122E24-61PY	-	DEUTSCH 456-24-61SY	ELECTRO 900-400-1218-03
POWER SUPPLY VIDEO CONVERTER	2J1	MS3122E20-16P	-	LS13580F20-16SN	LS12686G20
	2J2	MS3122E18-32S	-	LS13580F18-32PN	ELECTRO 2154-18101-1203
	2J3	MS3122E24-61SW	-	LS13580F24-61PW	ELECTRO 2154-24161-1203
	2J4	MS3122E24-61S	-	LS13580F24-61PN	ELECTRO 2154-24161-1203
	2J5	MS3122E22-55S	-	-	-
	2J9	DAGE 2677-1	-	-	-
	2J7	DAGE 2677-1	-	DAGE 2675-1	-
	2J8	DAGE 2677-1	-	-	-
CONTROL, SERVO- MECHANISM	3J1	MS3122E24-61SX	-	LS13580F24-61PX	ELECTRO 2154-24161-1203
	3J2	MS3122E24-61PZ	-	LS13580F24-61SZ	ELECTRO 2154-24161-1203
	3J3	M81511/01EF01P1	-	M81511/56FF01S1	ELECTRO 2161-18121-1203
	3J4	MS3122E22-55SW	-	-	-
CONTROL, IRDS	4J1	MS3122E22-55P	-	LS13580F22-55SN	ELECTRO 2154-22121-1203
	4J2	MS3122E14-19P	-	LS13580F14-19SN	ELECTRO 2154-13801-1203
CONTROL, SIGHT TARGET TRACKING	5J1	MS3122E16-26P	-	LS13580F16-26SN	ELECTRO 2154-16081-1203
VIDEO INDICATOR	6J1	MS3112E8-4P	-	PT06CEB-45SR	LS12686G8
	6J2	DAGE 4679-1	-	DAGE 2743-1	-
	6J3	DAGE 4679-1	-	-	-

M10

FIGURE 10. IRDS interconnecting block diagram.

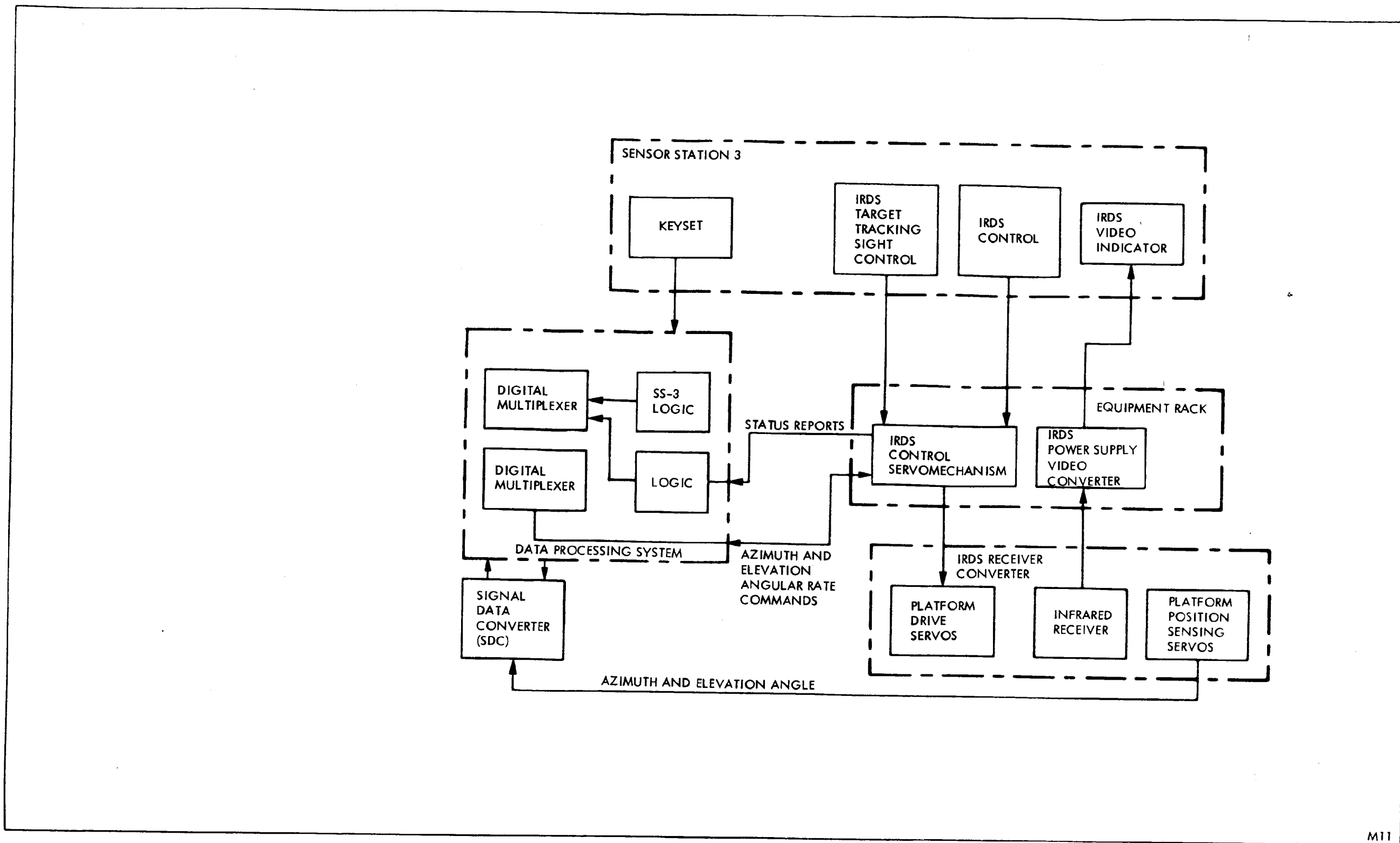

FIGURE 11. Typical IRDS/data processing system interfaces (P-3C).





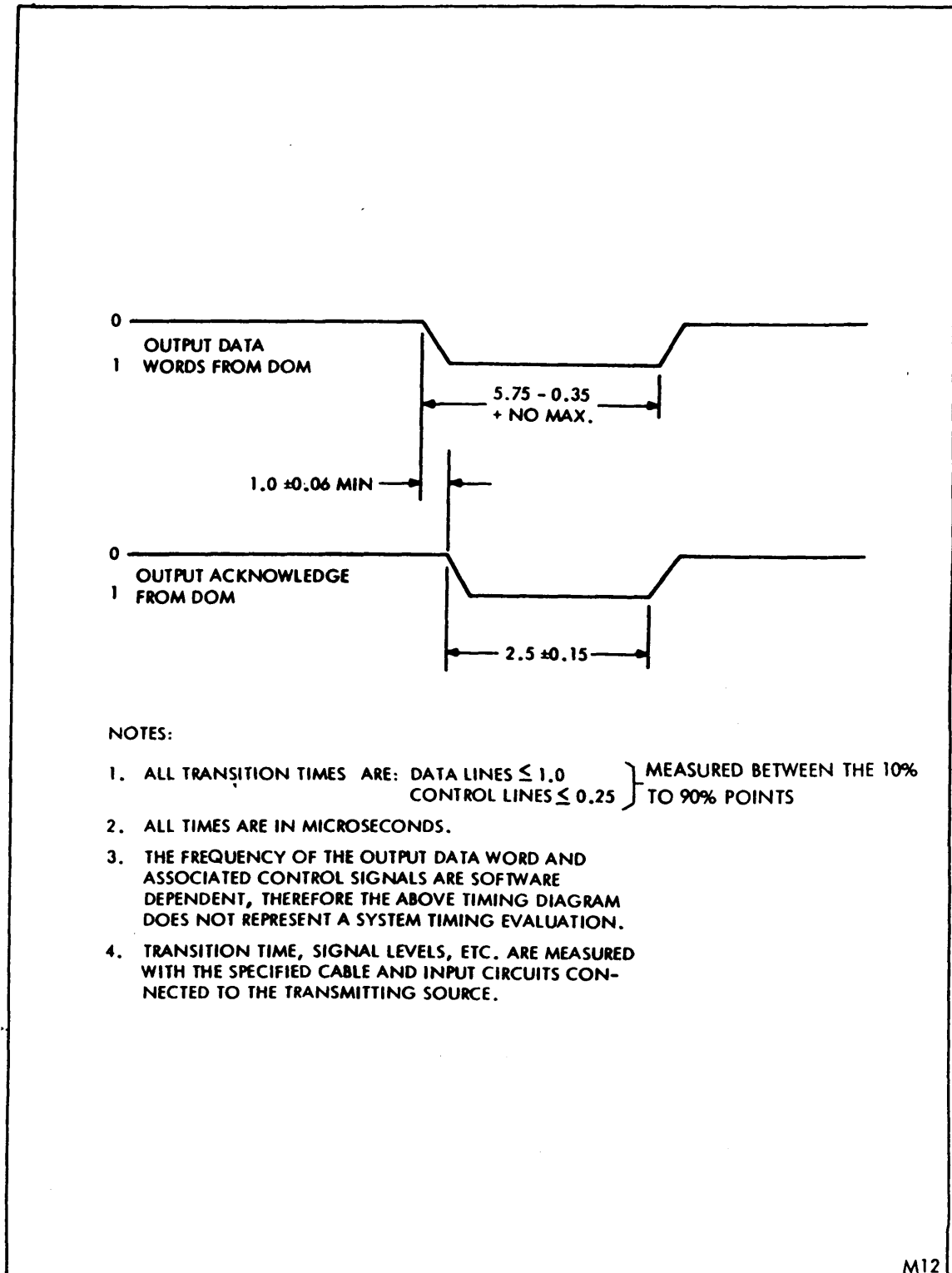

FIGURE 12. DOM/IRDS interface timing diagram (P-3C).

MIL-HDBK-258 (AS)

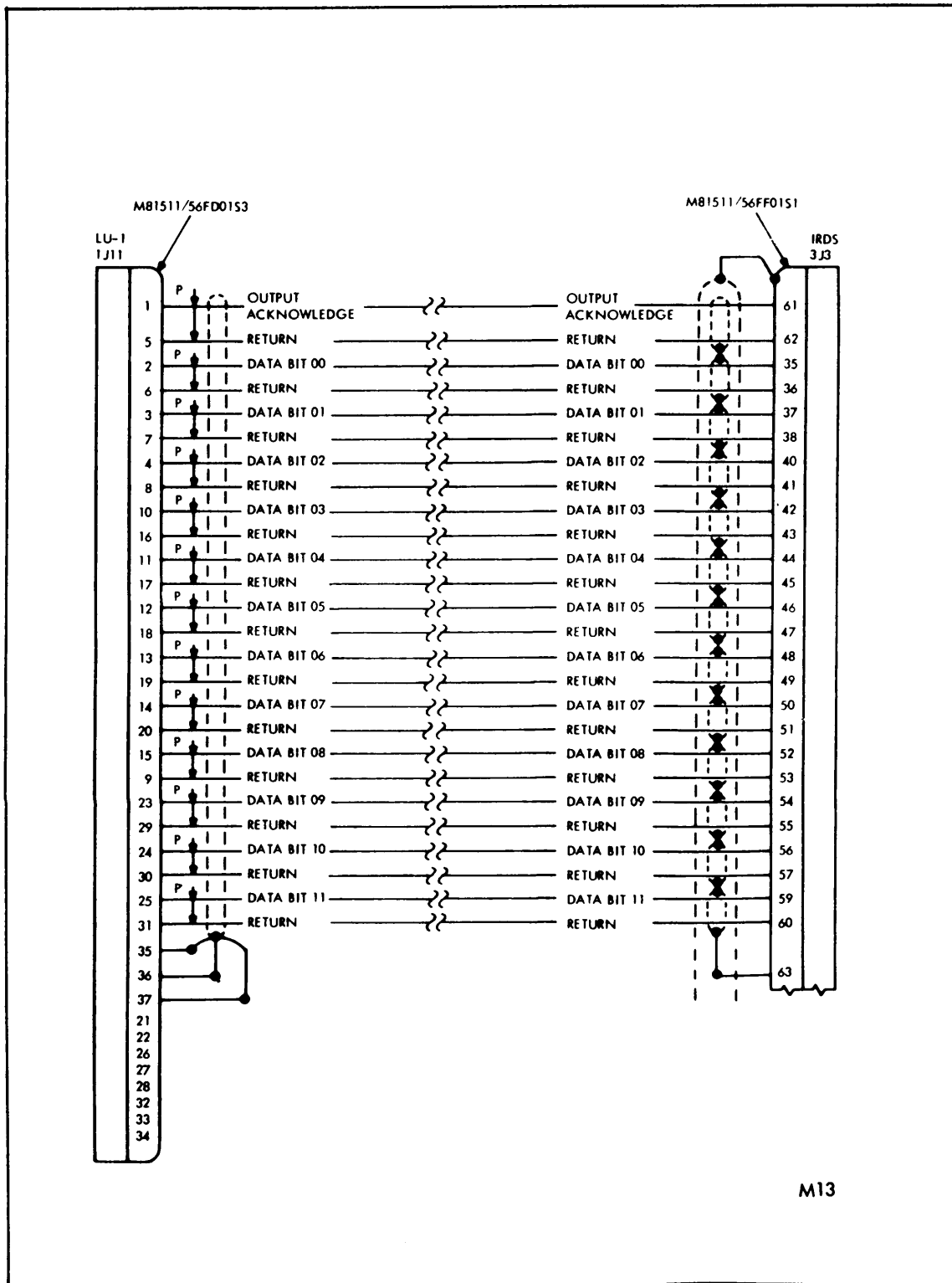

FIGURE 13. LU-1 DOM/IRDS CONTROL SERVOMECHANISM INTERFACE (P-3C).

	ORIGIN		TERMINATION
EQUIPMENT	DPS AN/AYA-8		IRDS
UNIT	Logic Unit 1- DOM		Control Servomechanism
CONNECTION	1J11-25,31		3J3-59,60
<b>CHARACTERISTICS:</b>			
WIRE		Logic "1" Voltage	0 + 0.5 - 0.0 VDC Sinking 40 MA
SIZE	See Schematic 22, 24 GA	Logic "0" Voltage	4 + 1 VDC Sourcing 10 MA
LENGTH	100 Ft. Max (overall)	Rise Time (10-90%)	1.0 usec Max
TYPE	See Schematic Twisted Pr/Shielded	Fall Time (10-90%)	1.0 usec Max
Line Receiver AC input impedance	130 Ohms Nom		
Line Receiver DC input impedance	2000 Ohms Nom		
<b>REMARKS:</b>			
<p>Aircraft installation requirements are as specified in WR-101, Part I.            Interface timing is per FIGURE 12.            This will be the most significant bit (MSB). Specified logic levels            measured with cable meeting characteristics of 130 Ohms impedance,            bandwidth of 10 MHz and attenuation factor of one percent or less.</p>			
<b>SCHEMATIC</b>			

FIGURE 14. Data bit 11 signal characteristics.

MIL-HDBK-258 (AS)

	ORIGIN		TERMINATION
EQUIPMENT	DPS (AN/AYA-8)		IRDS
UNIT	Logic Unit 1- DOM		Control Servomechanism
CONNECTION	1J11-2,6		3J3-35,36
<b>CHARACTERISTICS:</b>			
WIRE		Logic "1" Voltage	0 + 0.5 - 0.0 VDC Sinking 40 MA
SIZE	See Schematic 22-24 GA	Logic "0" Voltage	4 ± 1 VDC Sourcing 10 MA
LENGTH	100 Ft. Max (Overall)	Rise Time (10-90%)	1.0 usec Max
TYPE	See Schematic Twisted Pr/Shielded	Fall Time (10-90%)	1.0 usec Max
Line Receiver AC Input Impedance	130 Ohms Nom		
Line Receiver DC Input Impedance	2000 Ohms Nom		
<b>REMARKS:</b>			
<p>Aircraft installation requirements are as specified in WR-101, Part 1.                      Interface timing is per FIGURE 12. This will be the least significant bit (LSB).                      Specified logic levels measured with cable meeting characteristics of 130 Ohms impedance, bandwidth of 10 MHz and attenuation factor of one percent or less.</p>			
<b>SCHEMATIC</b>			
<p>CONTROL SERVO-MECHANISM</p> <p>LINE RECEIVER T.I. 536993 OR EQUIVALENT THRESHOLD 1.5 ± 0.7 VDC</p> <p>LU-1 DOM</p> <p>LINE DRIVER GE 7528376 OR EQUIVALENT</p> <p>M15</p>			

FIGURE 15. Data bit 00 signal characteristics.

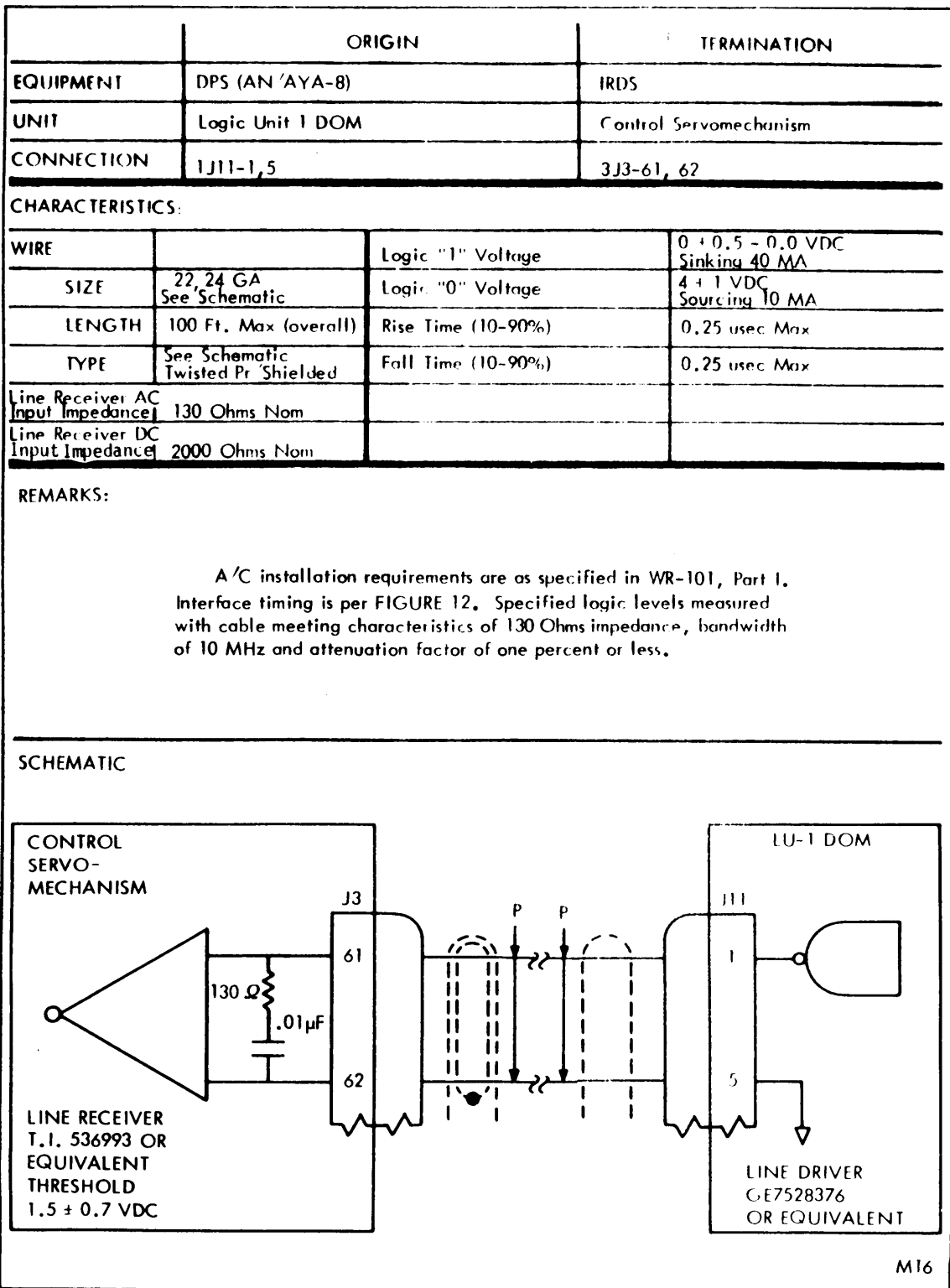

FIGURE 16. Output acknowledge signal characteristics.

MIL-HDBK-258 (AS)

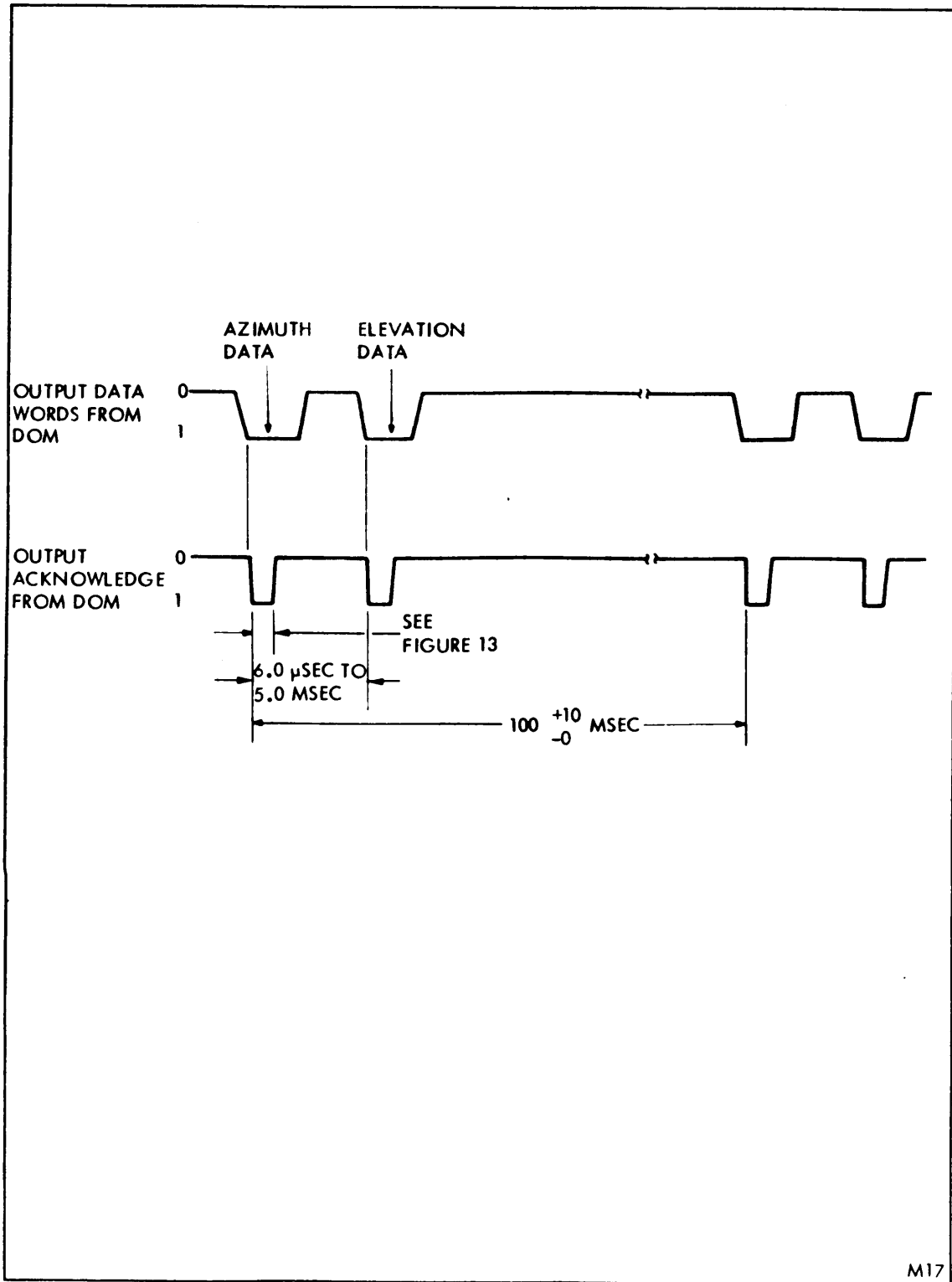

FIGURE 17. DOM/IRDS data update timing requirements.

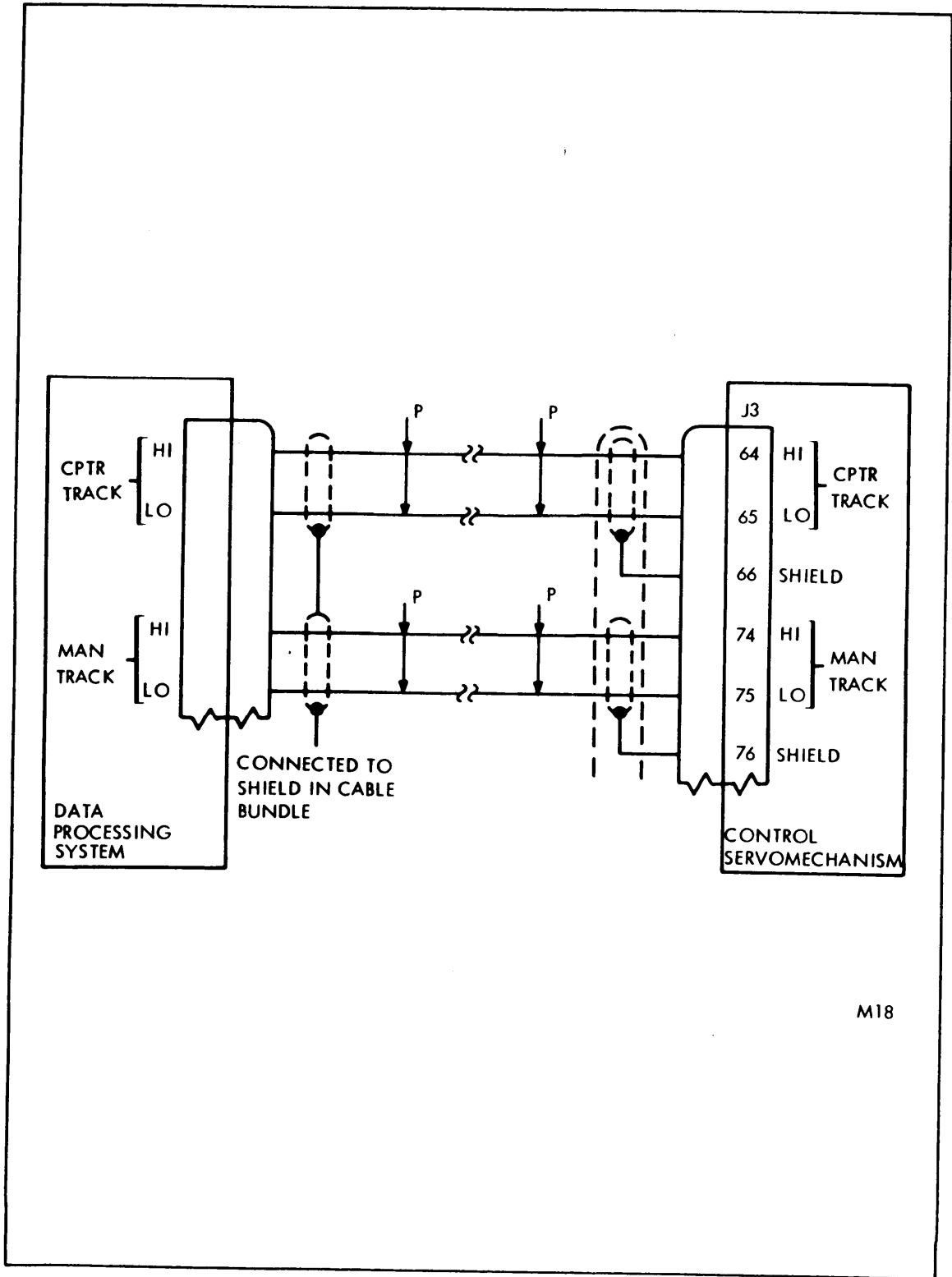

FIGURE 18. IRDS/data processing system status logic interface (P-3C).

MIL-HDBK-258 (AS)

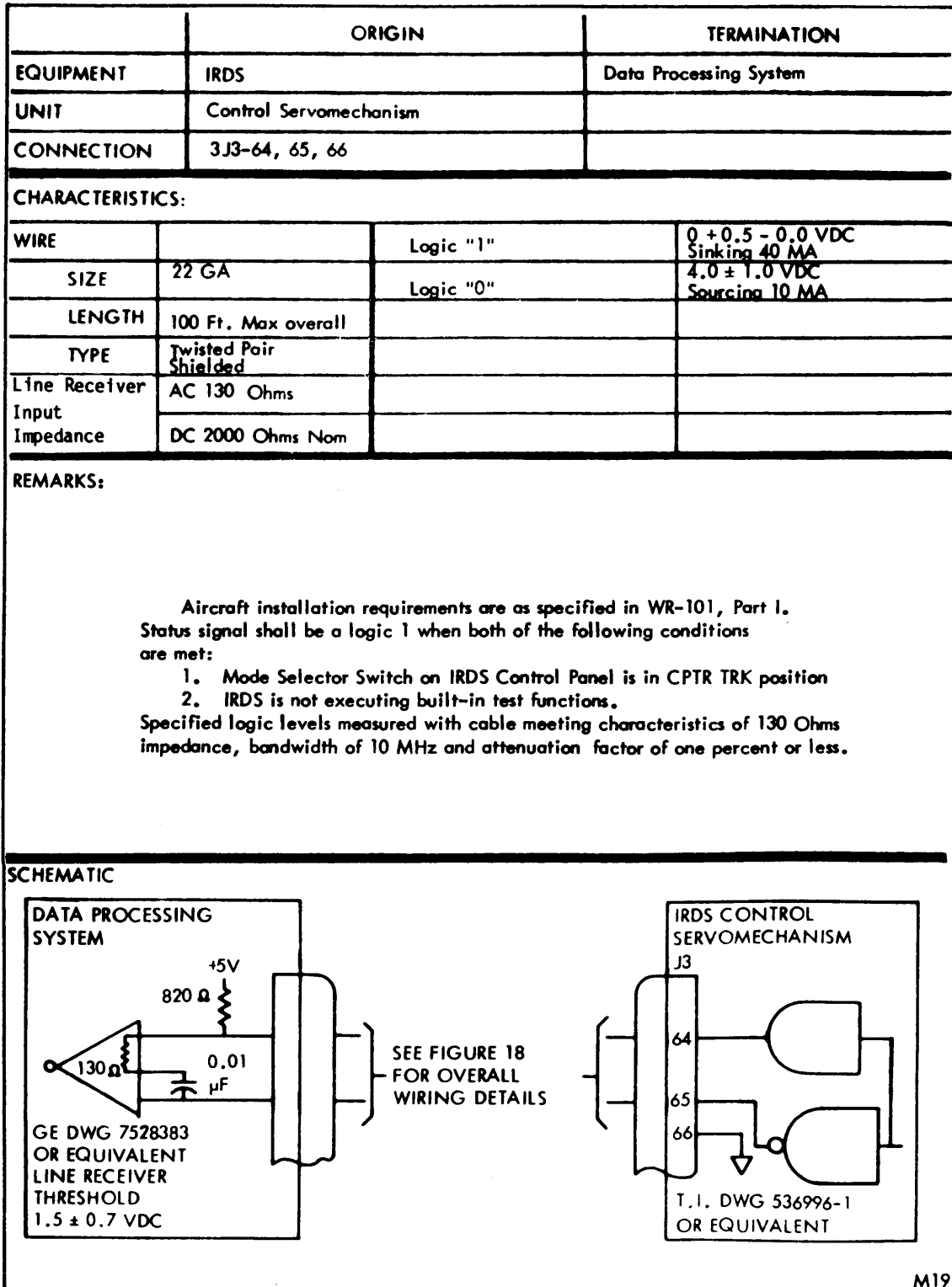

FIGURE 19. Computer track signal characteristics.

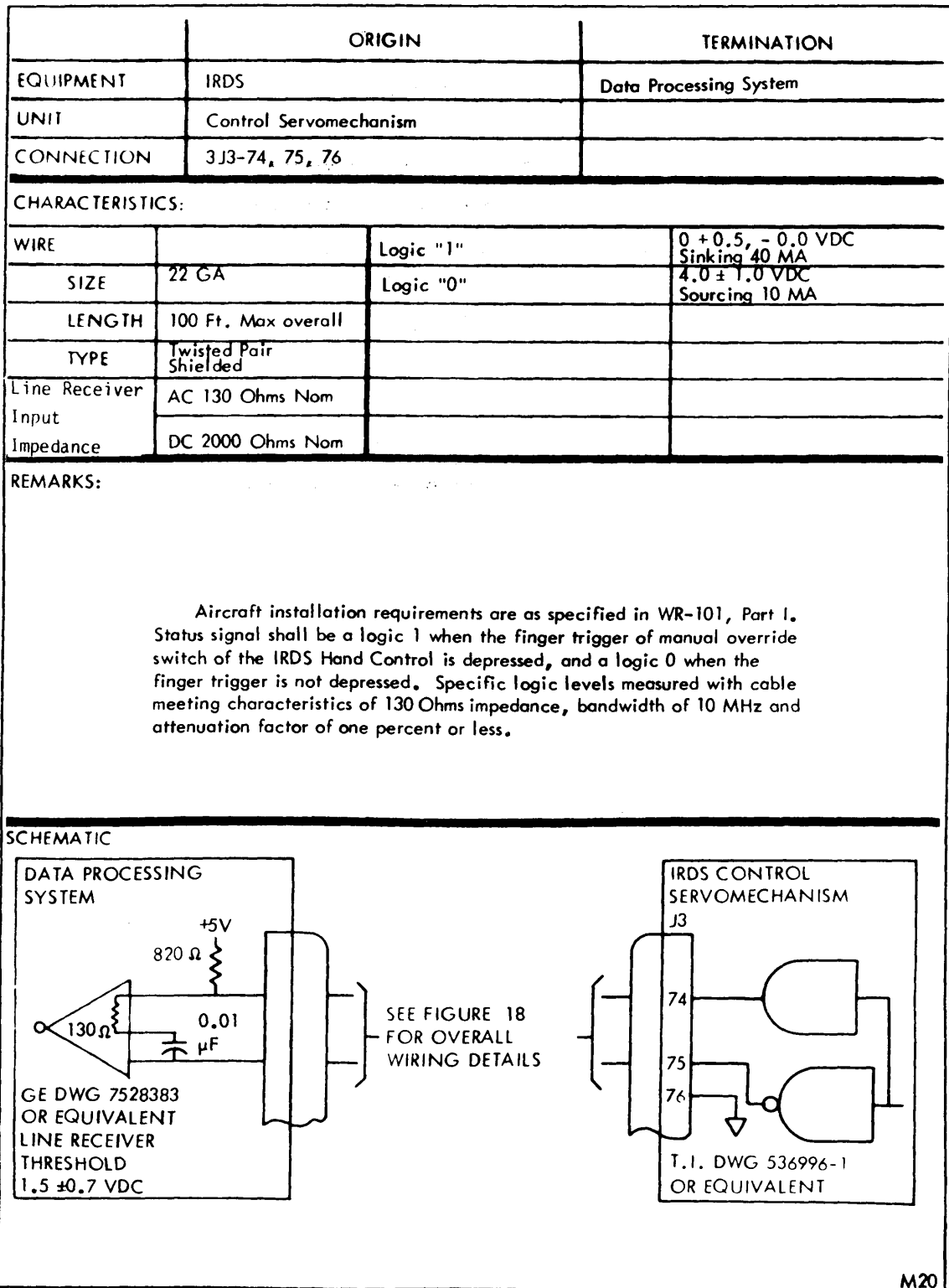

FIGURE 20. Manual track override signal characteristics.

MIL-HDBK-258 (AS)

	ORIGIN		TERMINATION
EQUIPMENT	IRDS		Signal Data Converter
UNIT	Control Servomechanism		
CONNECTION	3J3 - 67, 68, 69		
<b>CHARACTERISTICS:</b>			
WIRE		Voltage (Line to Line)	0 to 11.8 VRMS (400 Hz)
SIZE	22 GA	Impedance (SDS)	5000 ohms Min (Line to Line)
LENGTH	40 Ft. Max Overall	Load Unbalance	(TBD) Ohms Min $\pm 2\%$ (Line to Line)
TYPE	M27500A22-ML3T08	For Load of 5000 ohms synchro zero will represent	
	or equivalent	a zero azimuth angle when aircraft wiring in	
		accordance with FIGURE 24 is provided.	
<b>REMARKS:</b>			
<p>Aircraft installation requirements are as specified in WR-101, Part I.</p>			
M21			

FIGURE 21. IRDS az position signal characteristics.

	ORIGIN		TERMINATION
EQUIPMENT	IRDS		Signal Data Converter
UNIT	Control Servomechanism Unit		
CONNECTION	3J3 - 70, 71, 72, 73		
<b>CHARACTERISTICS:</b>			
WIRE		Voltage (Line to Line)	0 to 11.8 VRMS (400 Hz)
SIZE	22 GA	Impedance (SDC)	5000 ohms min (Line to Line)
LENGTH	40 Ft. Max overall	Load Unbalance (Line to Line)	(TBD) ohms Min $\pm 2\%$ (Line to Ground)
TYPE	M27500A22-ML3T08 or equivalent	For Load of 5000 ohms synchro zero will represent a zero elevation angle when aircraft wiring in accordance with Figure 24 is provided.	
<b>REMARKS:</b>			
<p>Aircraft installation requirements are as specified in WR-101, Part I.</p>			
M22			

Figure 22. IRDS el position signal characteristics.

MIL-HDBK-258(AS)

	ORIGIN		TERMINATION
EQUIPMENT	Signal Data Converter		IRDS
UNIT			Control Servomechanism Unit
CONNECTION			3J3 - 32, 33, 34
<b>CHARACTERISTICS:</b>			
WIRE		Voltage	26 ± 3 VRMS, 400 Hz
SIZE	22 GA	Input Impedance (IRDS)	200 Ohms Min (400 Hz)
LENGTH	40 Ft. Max Overall	Line to Ground Impedance	2000 Ohms Min
TYPE	Twisted Pair Shielded		
<b>REMARKS:</b>			
<p>Aircraft installation requirements are as specified in WR-101, Part I.                      See FIGURE 24 for wiring details</p>			
M23			

FIGURE 23. 26 VAC reference voltage signal characteristics.

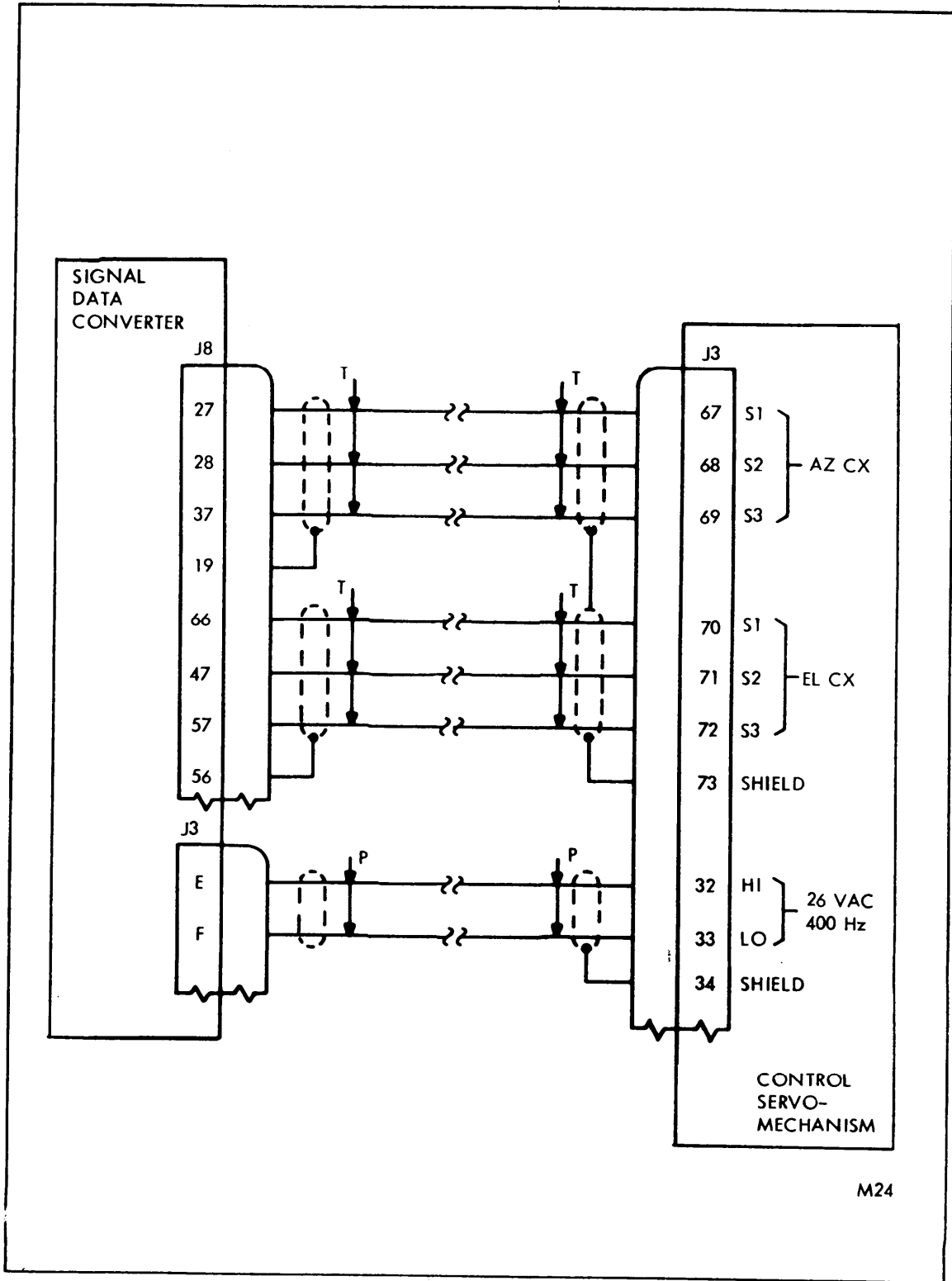

FIGURE 24. IRDS/signal data converter interwiring details.

MIL-HDBK-258 (AS)

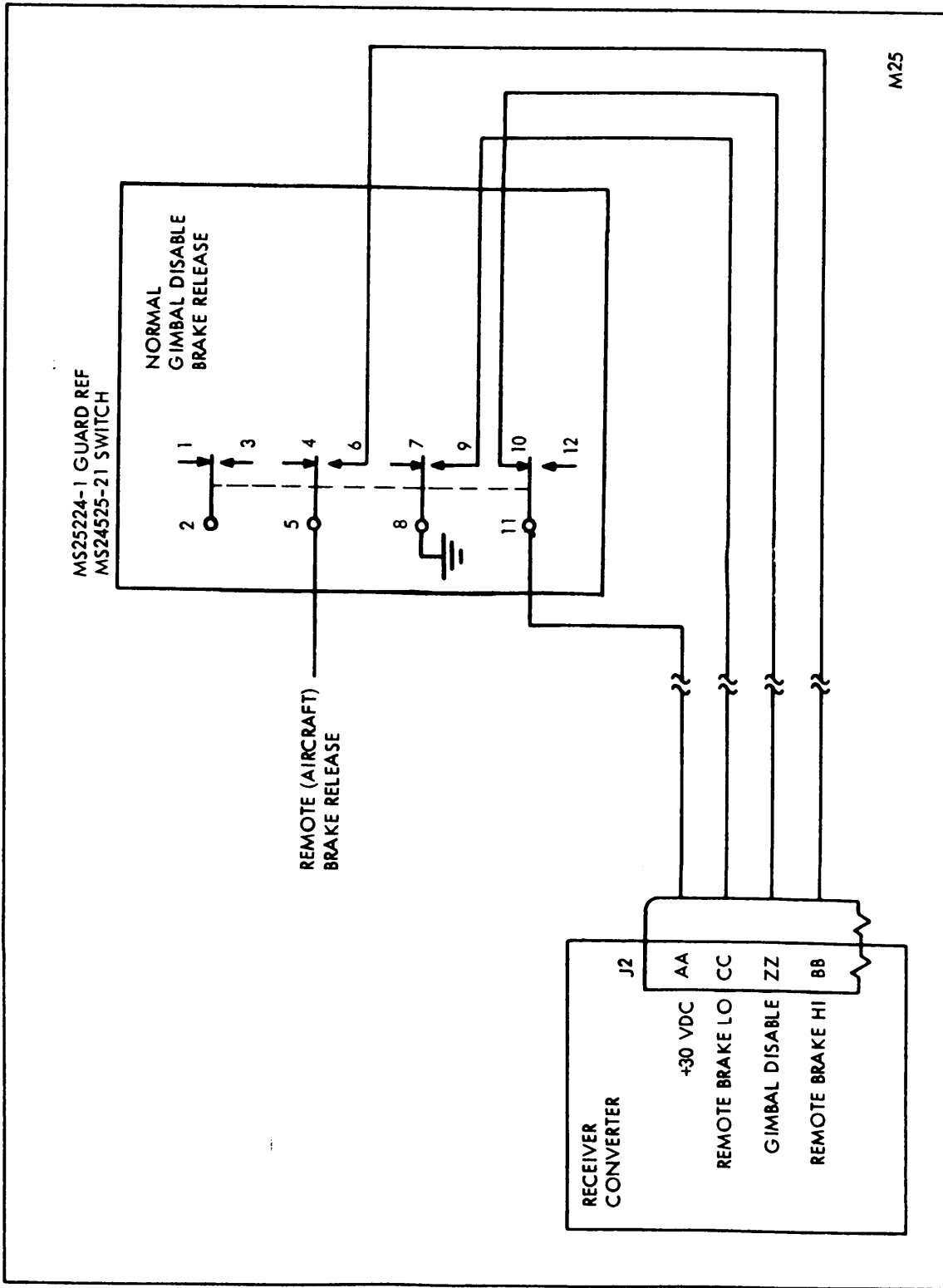

FIGURE 25. Maintenance switch/IRDS interface.

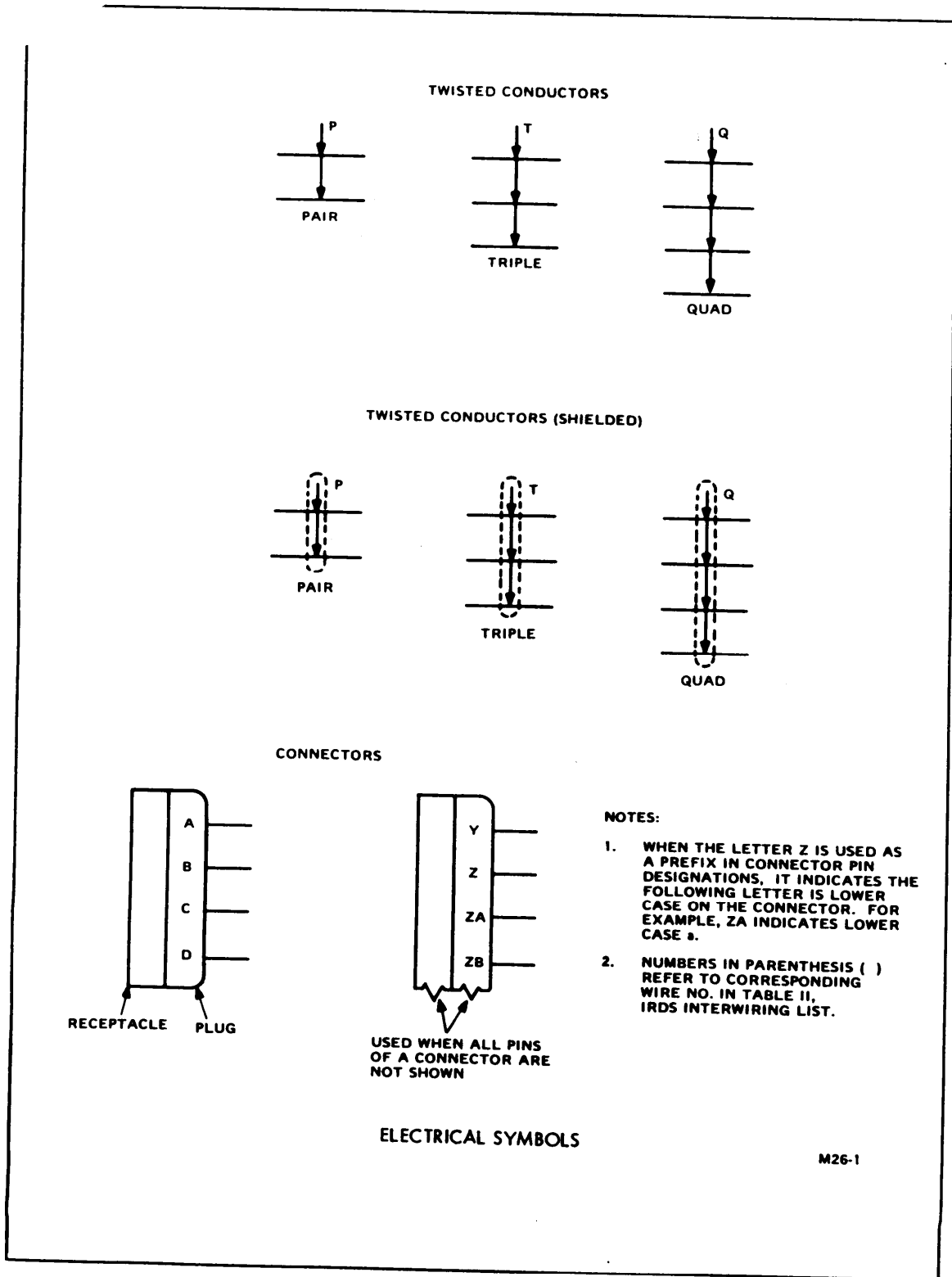

FIGURE 26. IRDS interconnecting diagram. (sheet 1 of 27)

MIL-HDBK-258 (AS)

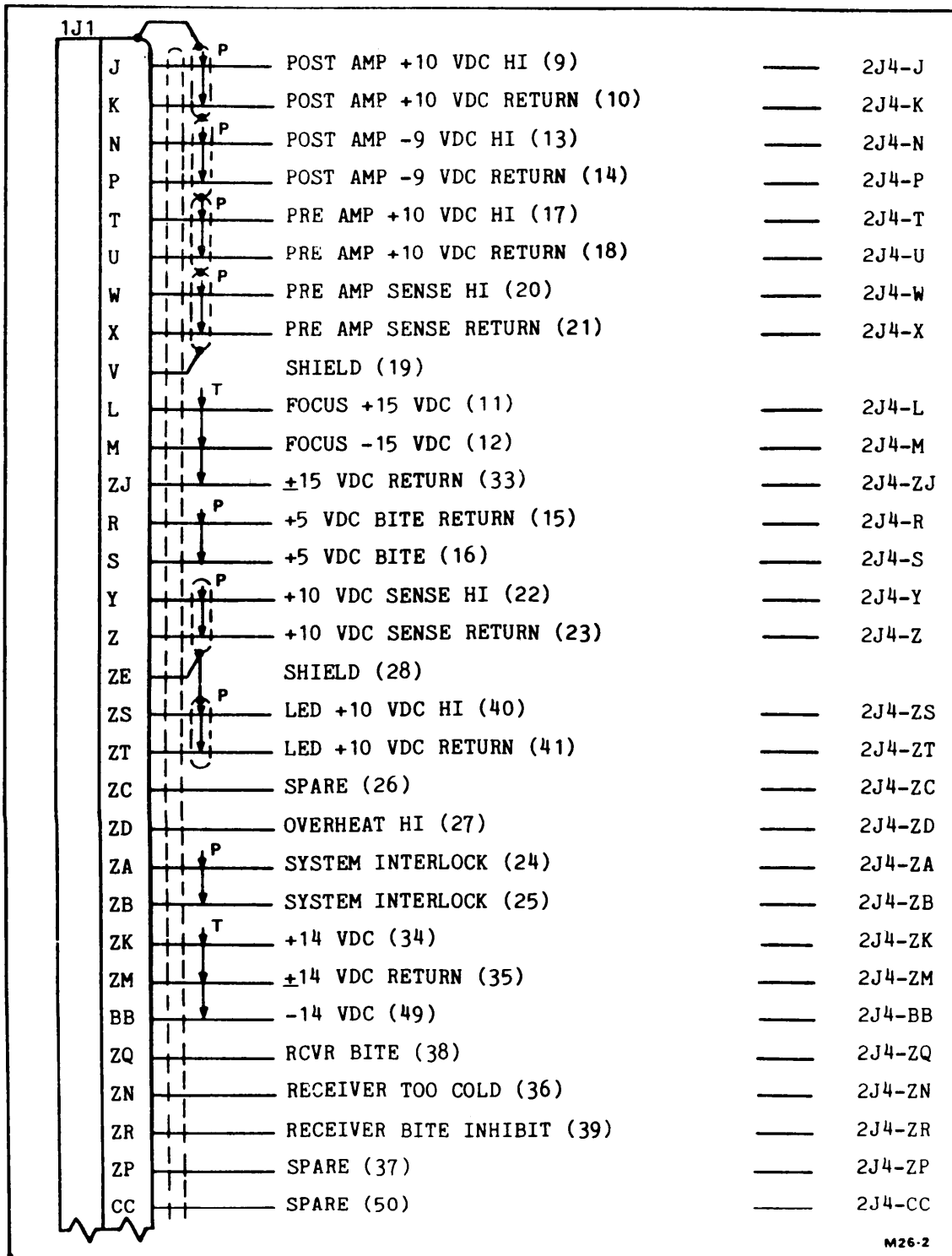
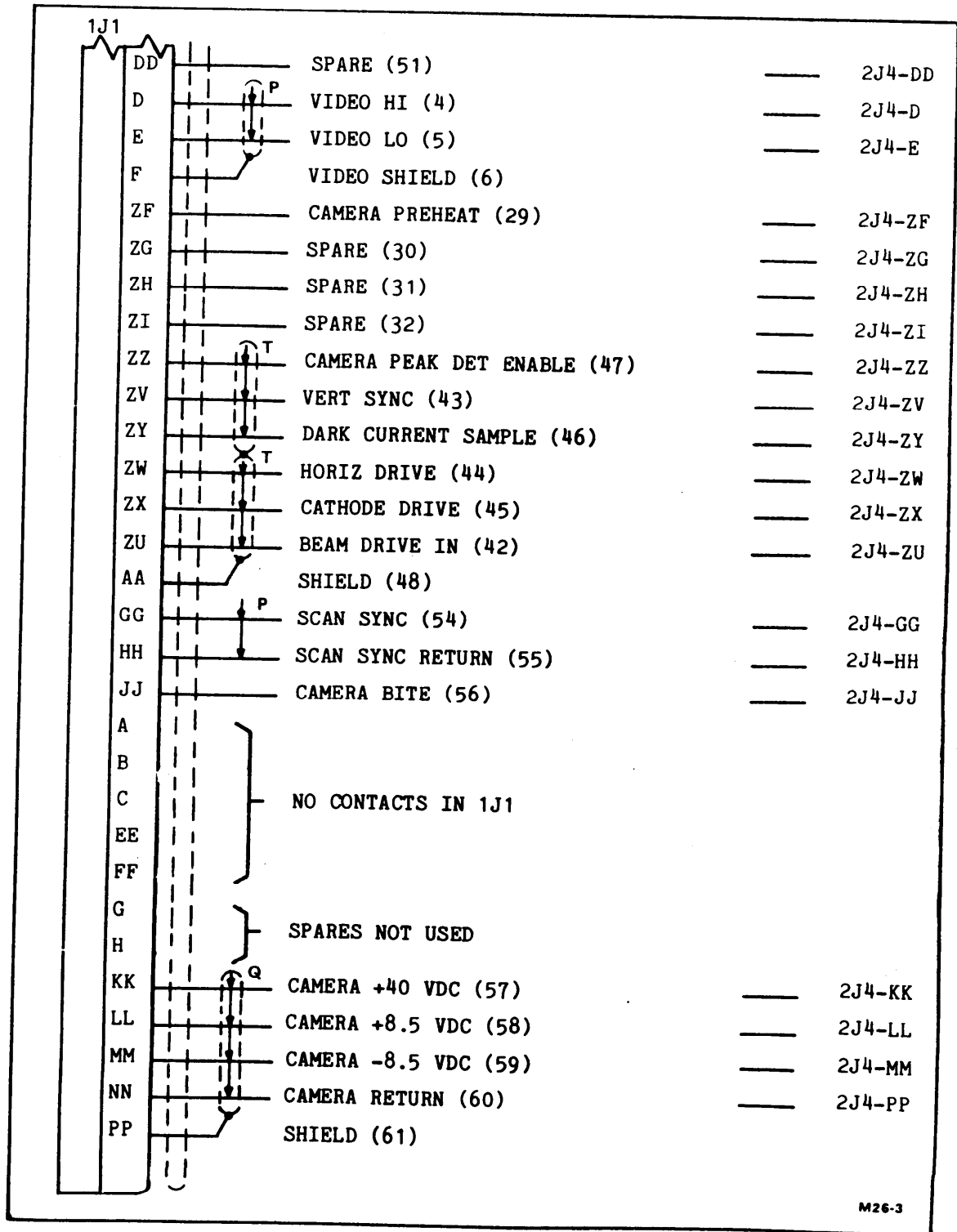

FIGURE 26. IRDS interconnecting diagram. (sheet 2 of 27)



M26-3

FIGURE 26. IRDS interconnecting diagram. (sheet 2 of 27).

MIL-HDBK-258(AS)

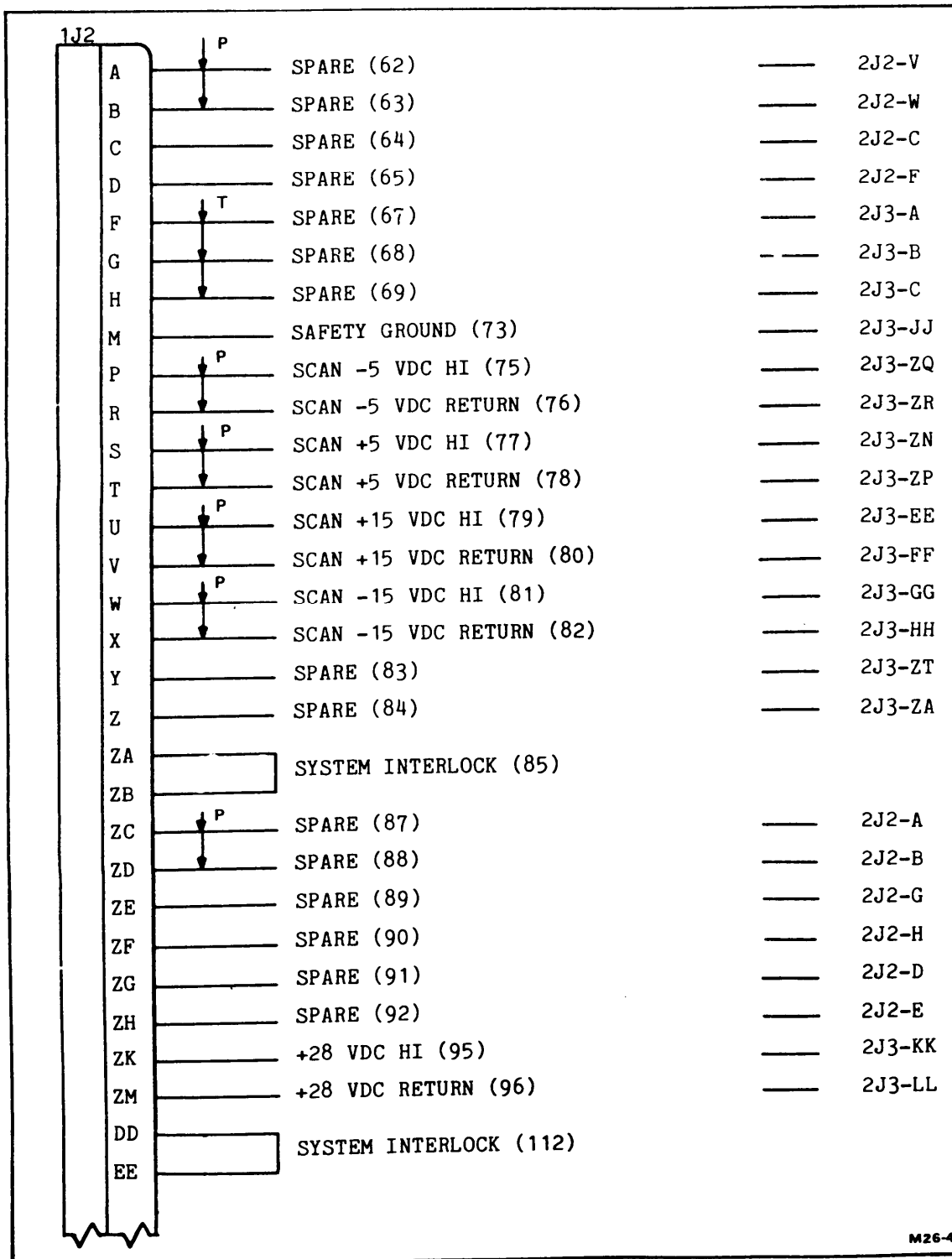

FIGURE 26. IRDS interconnecting diagram. (sheet 4 of 27)

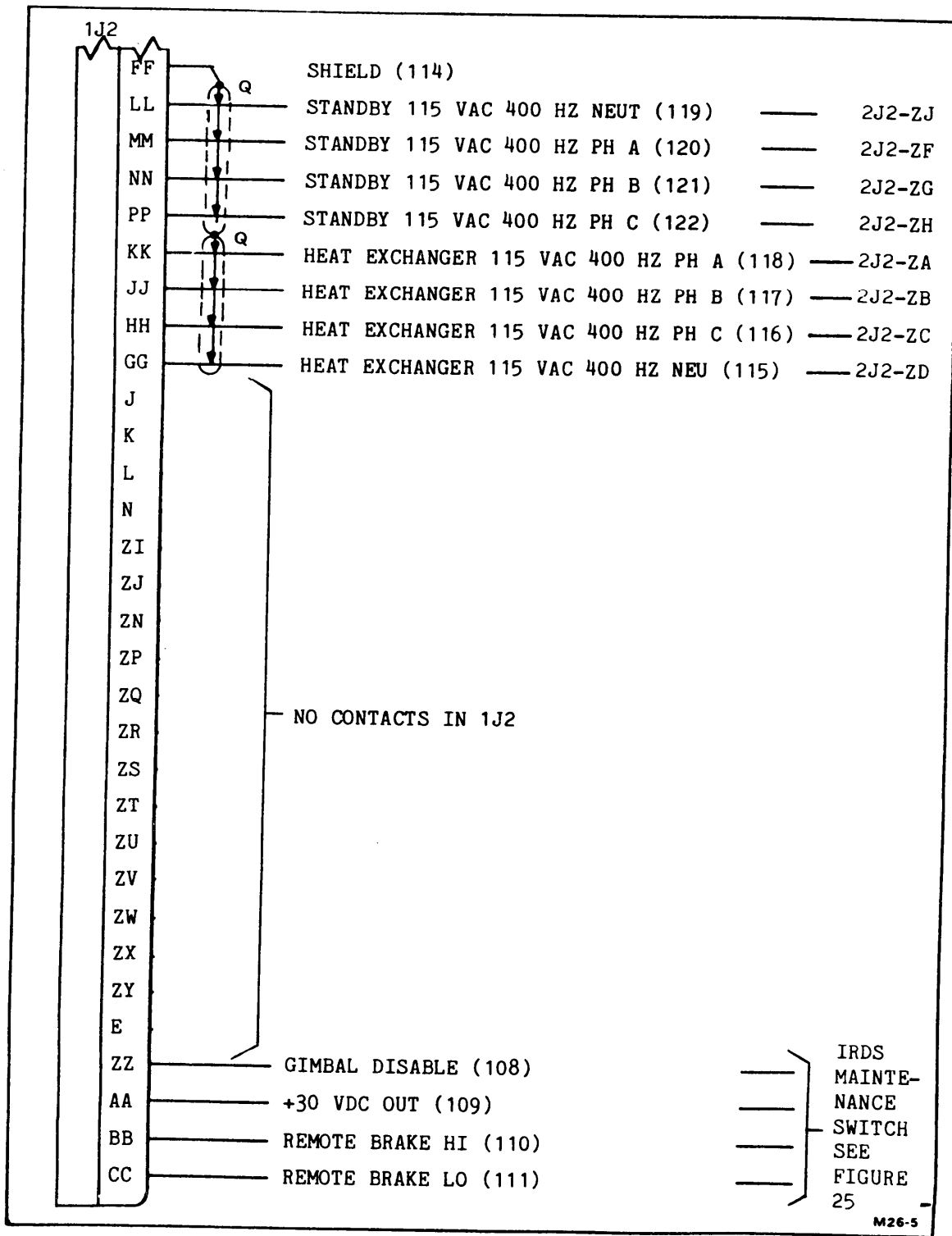

FIGURE 26. IRDS interconnecting diagram. (sheet 5 of 27)

MIL-HDBK-258 (AS)

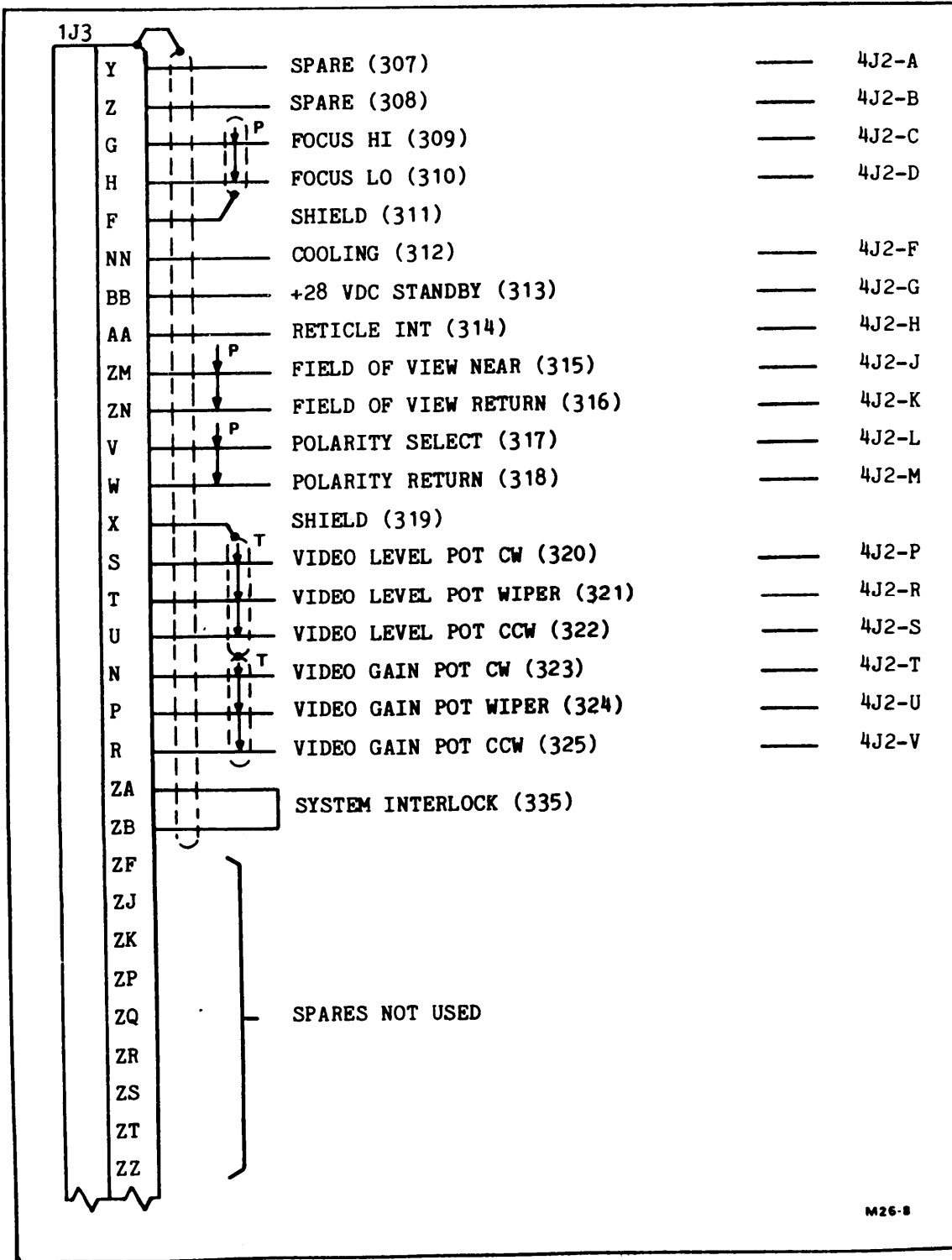

FIGURE 26. IRDS interconnecting diagram. (sheet 6 of 27)

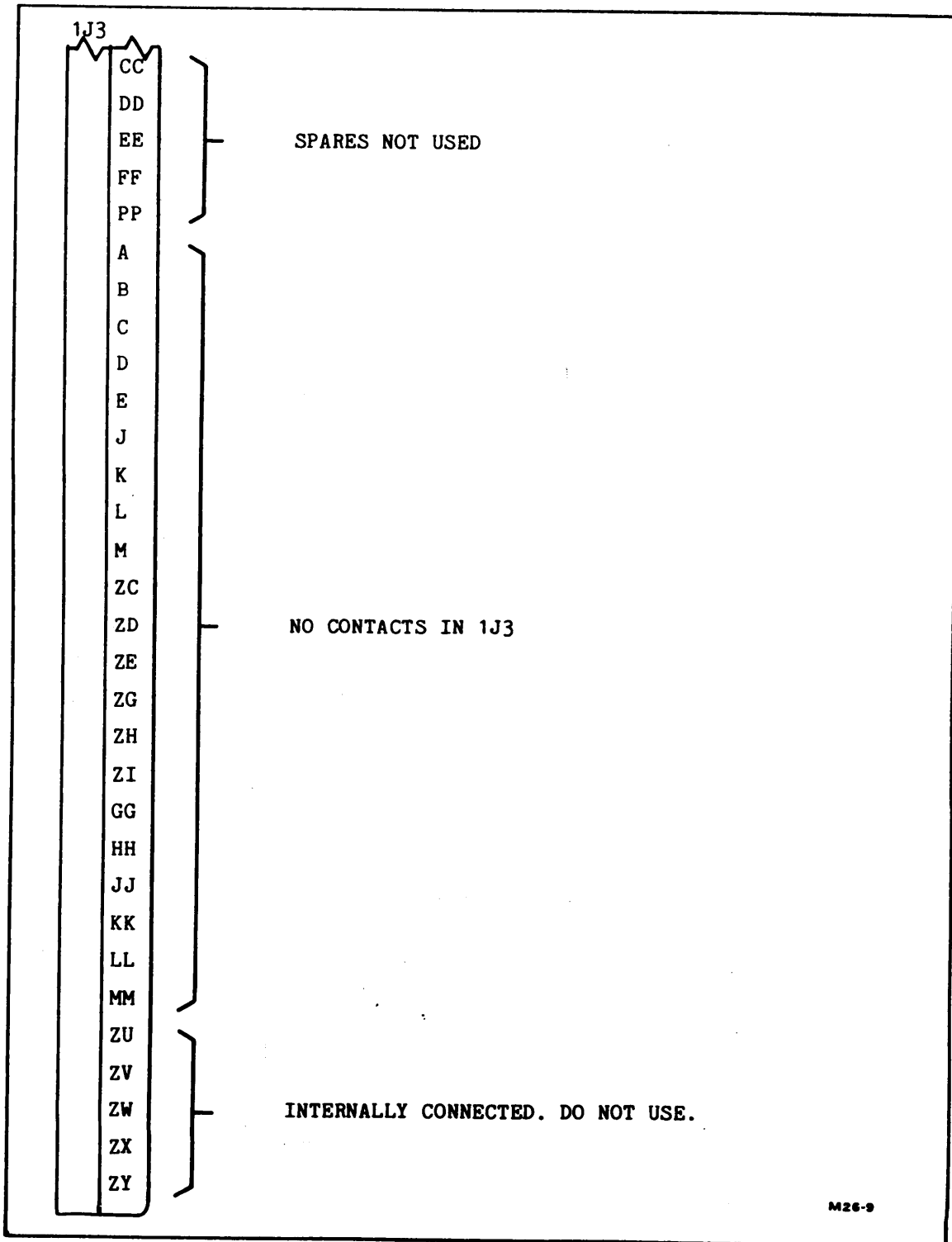
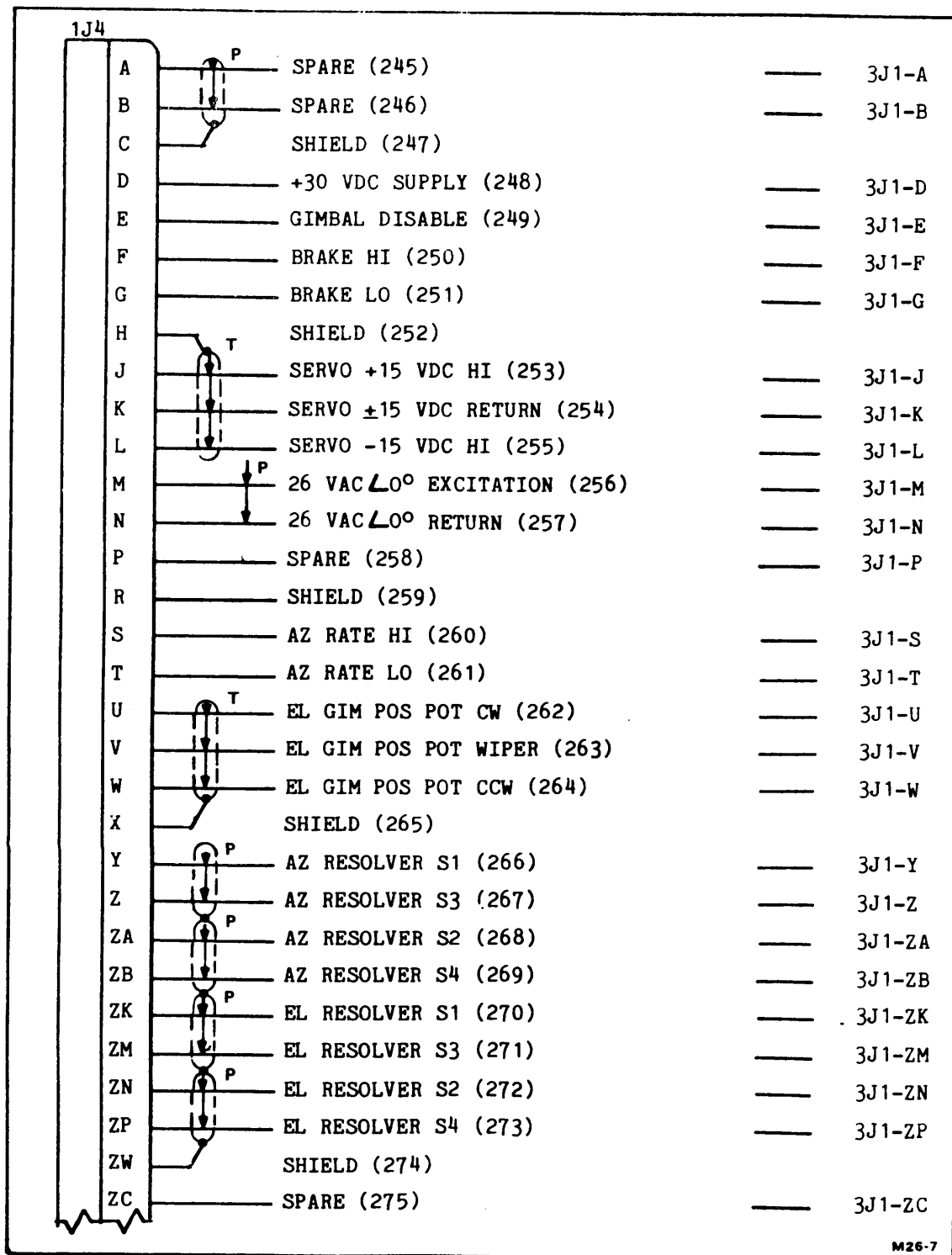

FIGURE 26. IRDS interconnecting diagram. (sheet 7 of 27)

MIL-HDBK-258(AS)



M26-7

FIGURE 26. IRDS interconnecting diagram. (sheet 8 of 27)

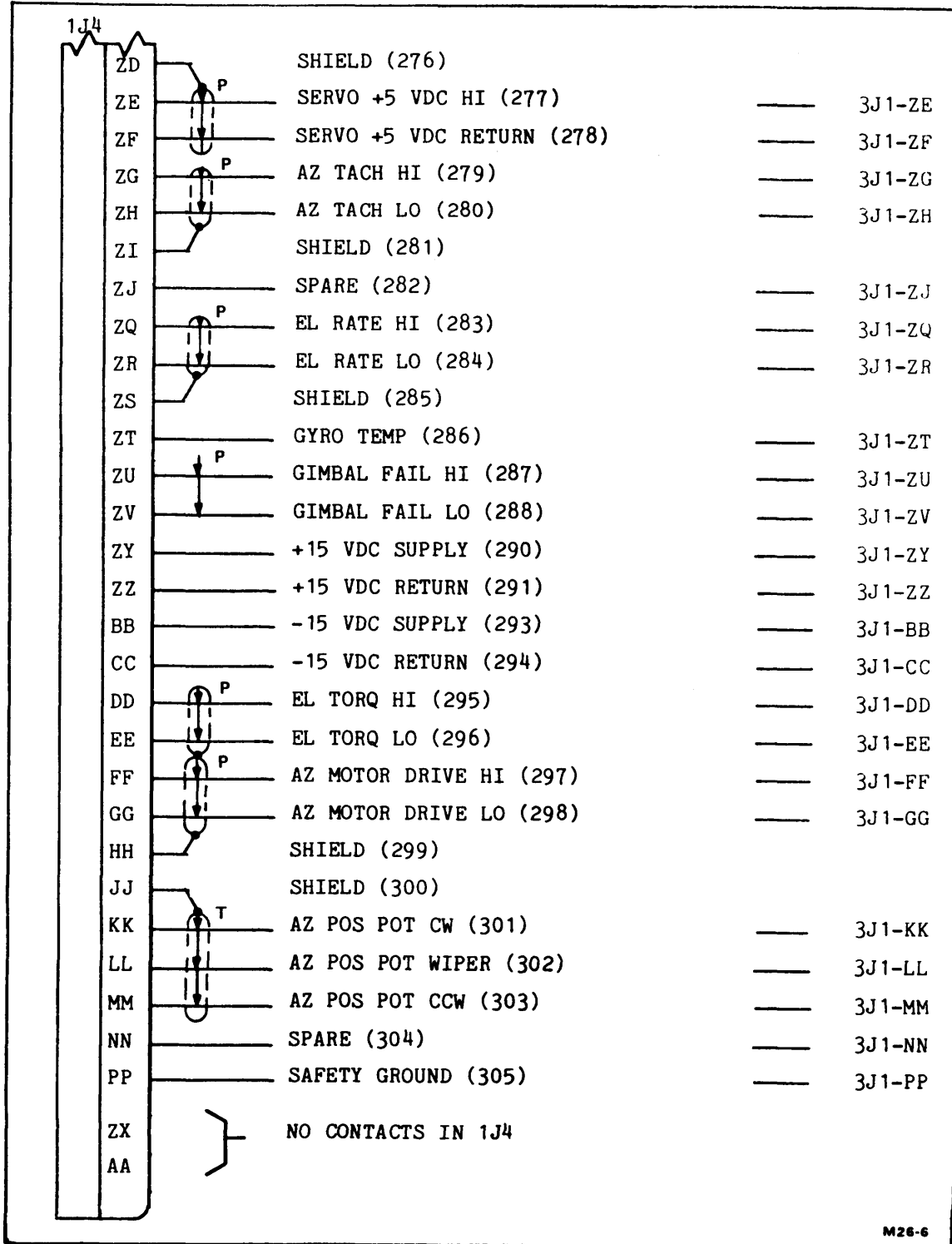
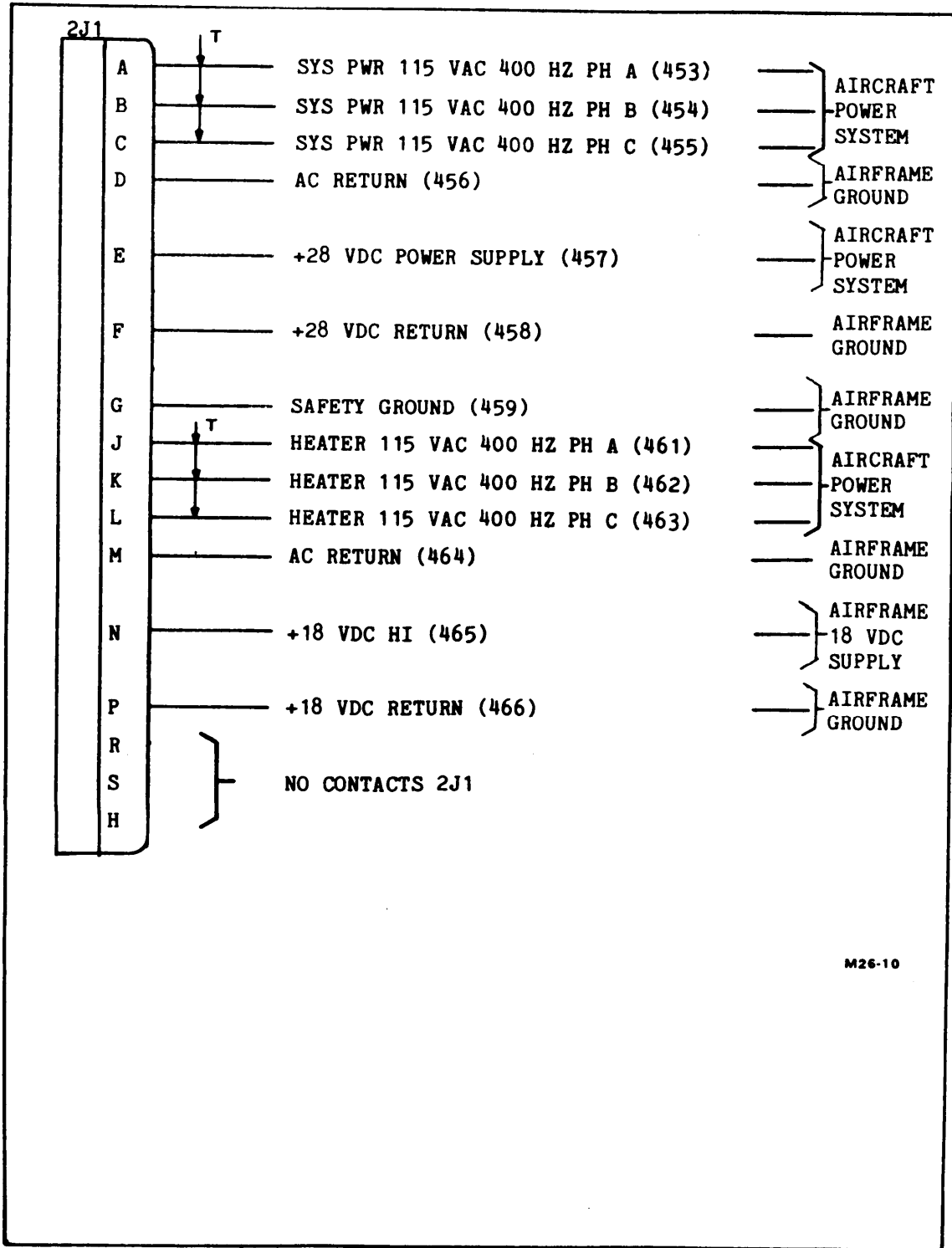

FIGURE 26. IRDS interconnecting diagram. (sheet 9 of 27)

MIL-HDBK-258 (AS)



M26-10

FIGURE 26. IRDS interconnecting diagram. (sheet 10 of 27)

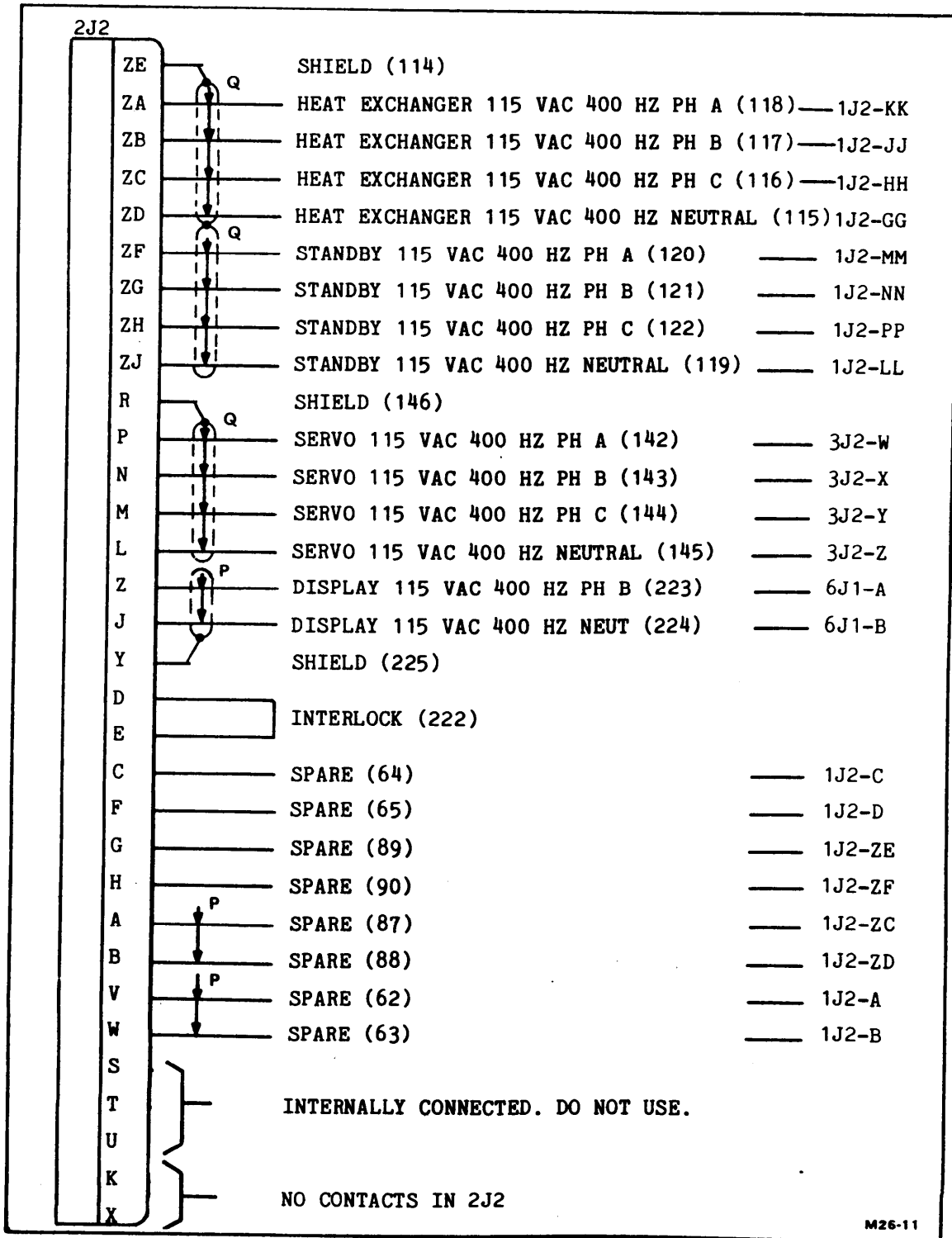

FIGURE 26. IRDS interconnecting diagram. (sheet 11 of 27)

MIL-HDBK-258 (AS)

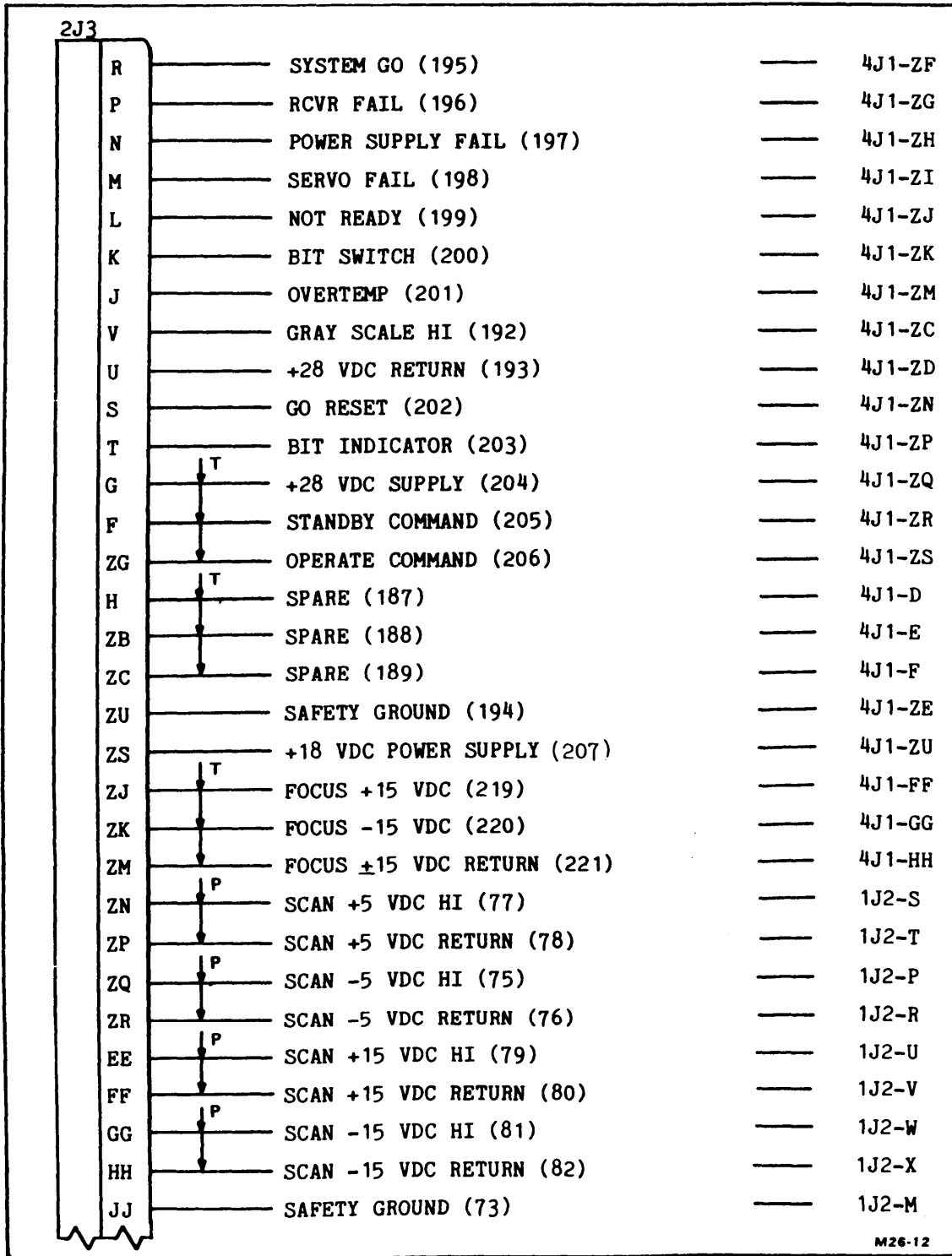
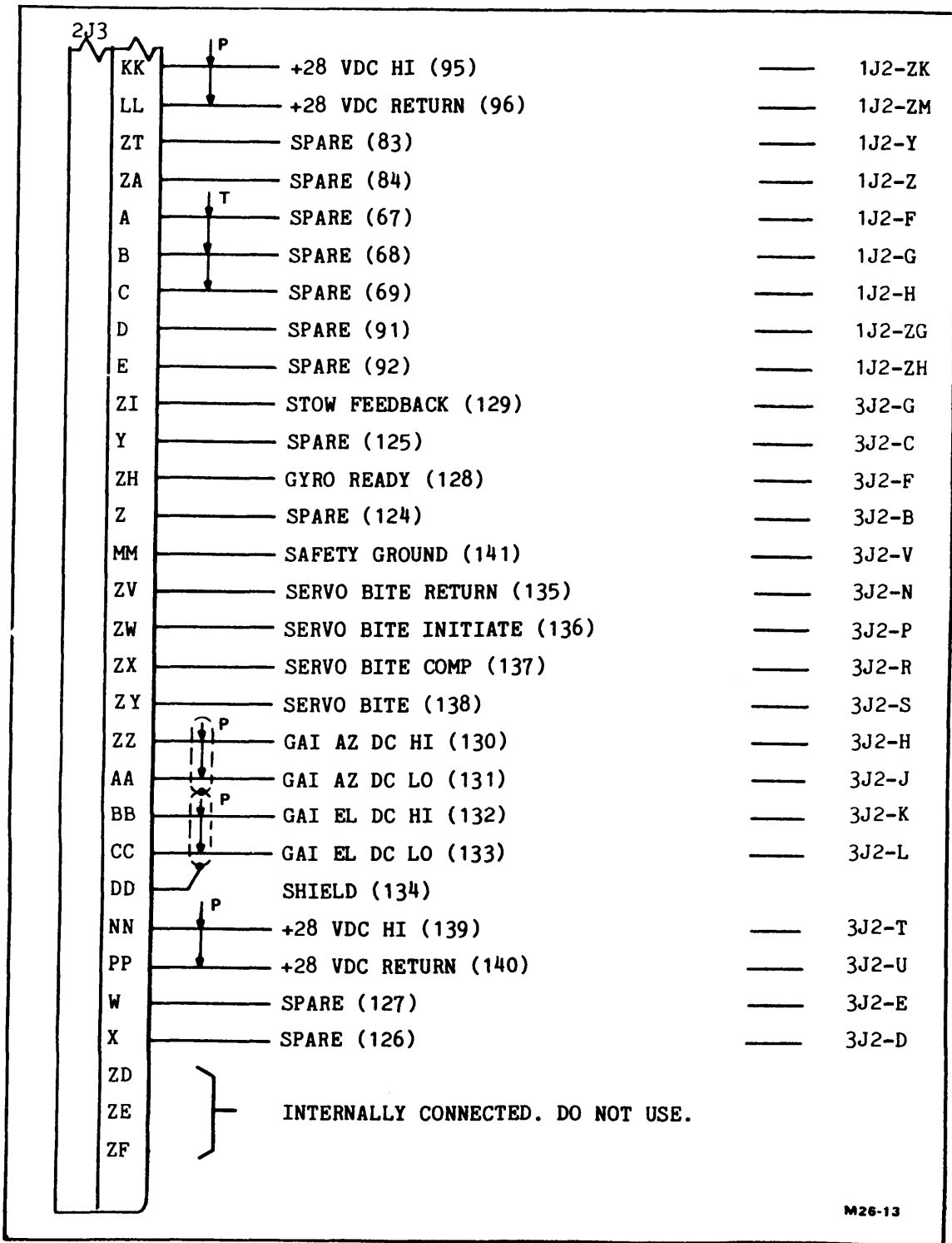

FIGURE 26. IRDS interconnecting diagram. (sheet 13 of 27)



M26-13

FIGURE 26. IRDS interconnecting diagram. (sheet 13 of 27)

MIL-HDBK-258 (AS)

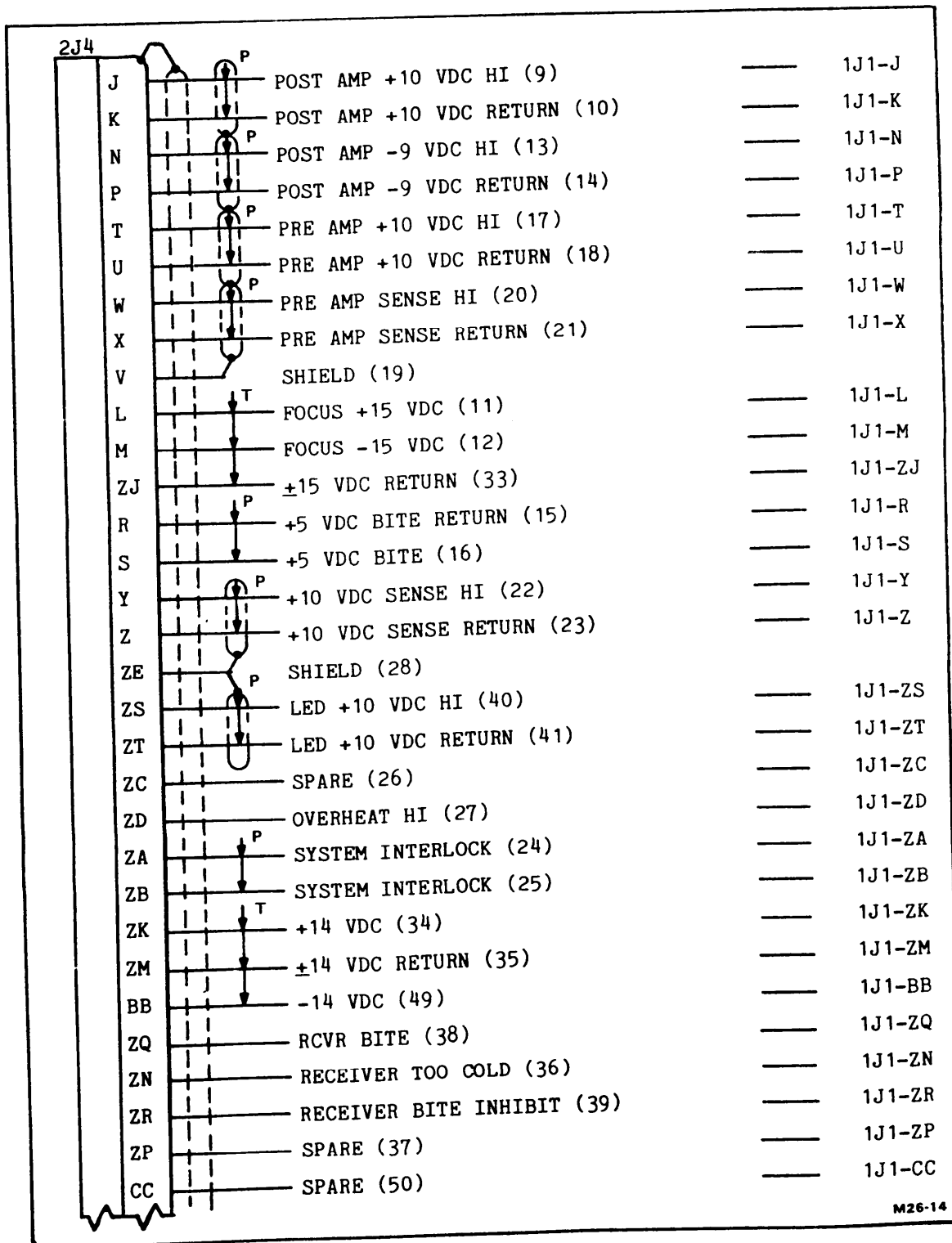

FIGURE 26. IRDS interconnecting diagram. (sheet 14 of 27)

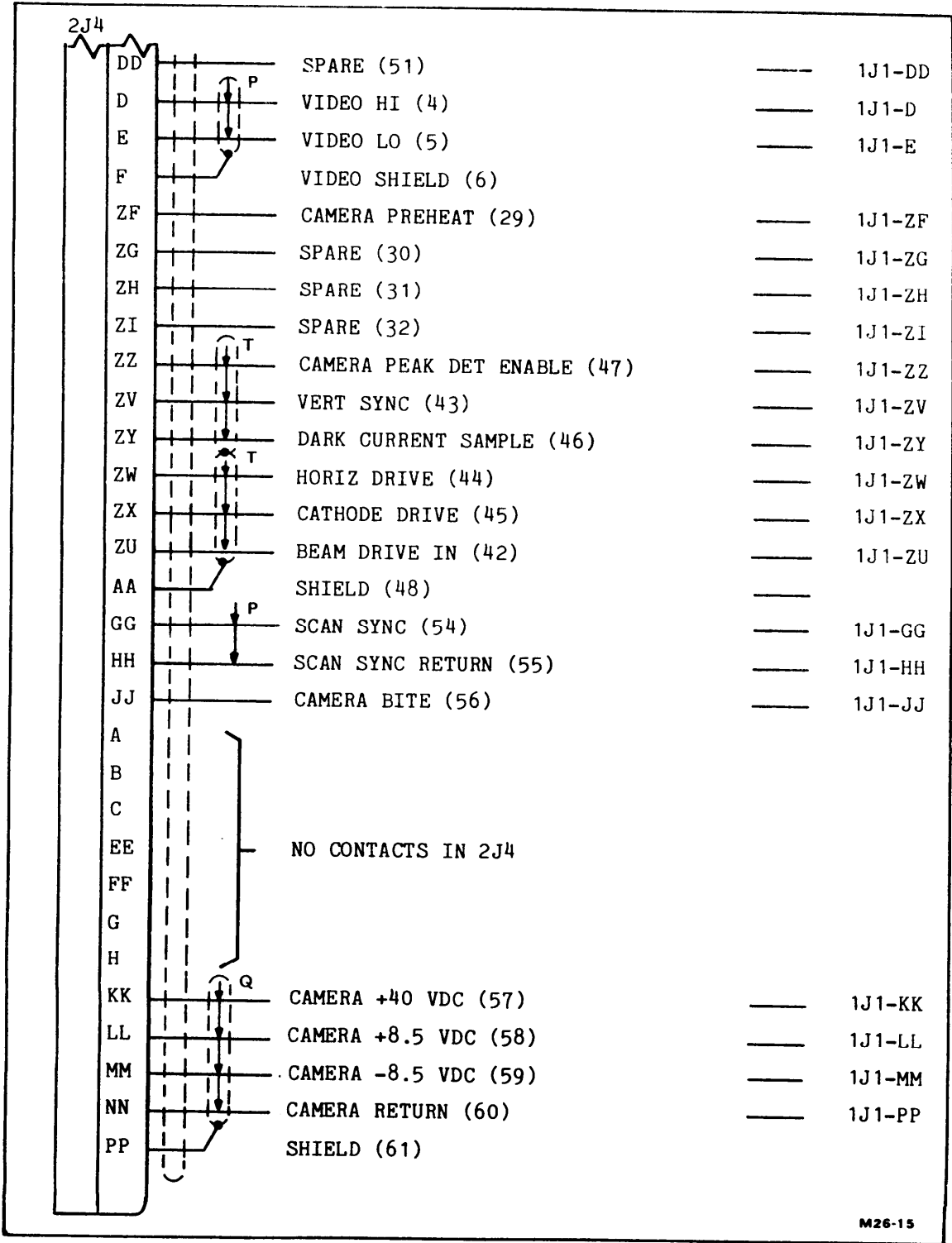

FIGURE 26. IRDS interconnecting diagram. (sheet 15 of 27)

MIL-HDBK-258 (AS)

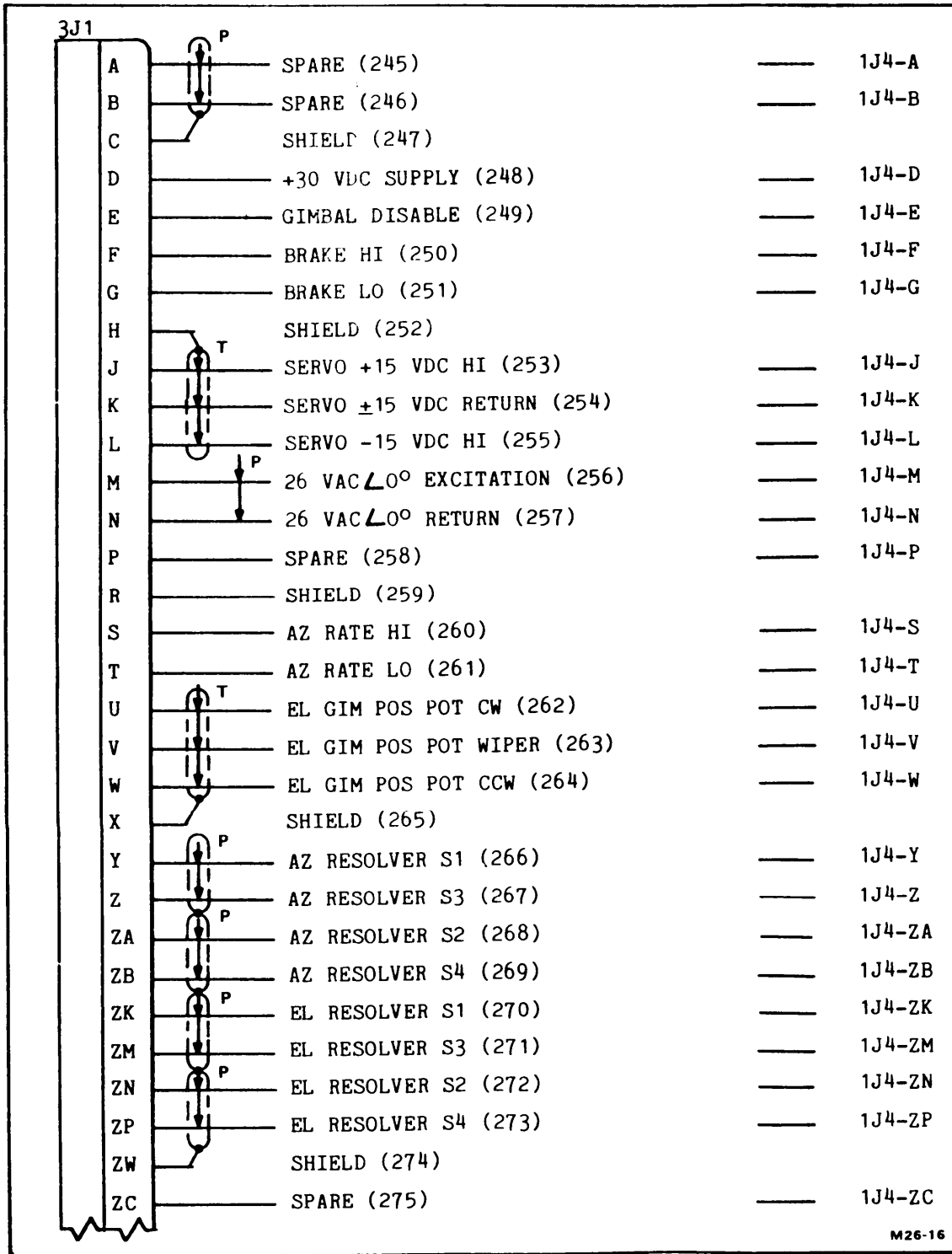

FIGURE 26. IRDS interconnecting diagram. (sheet 16 of 27)

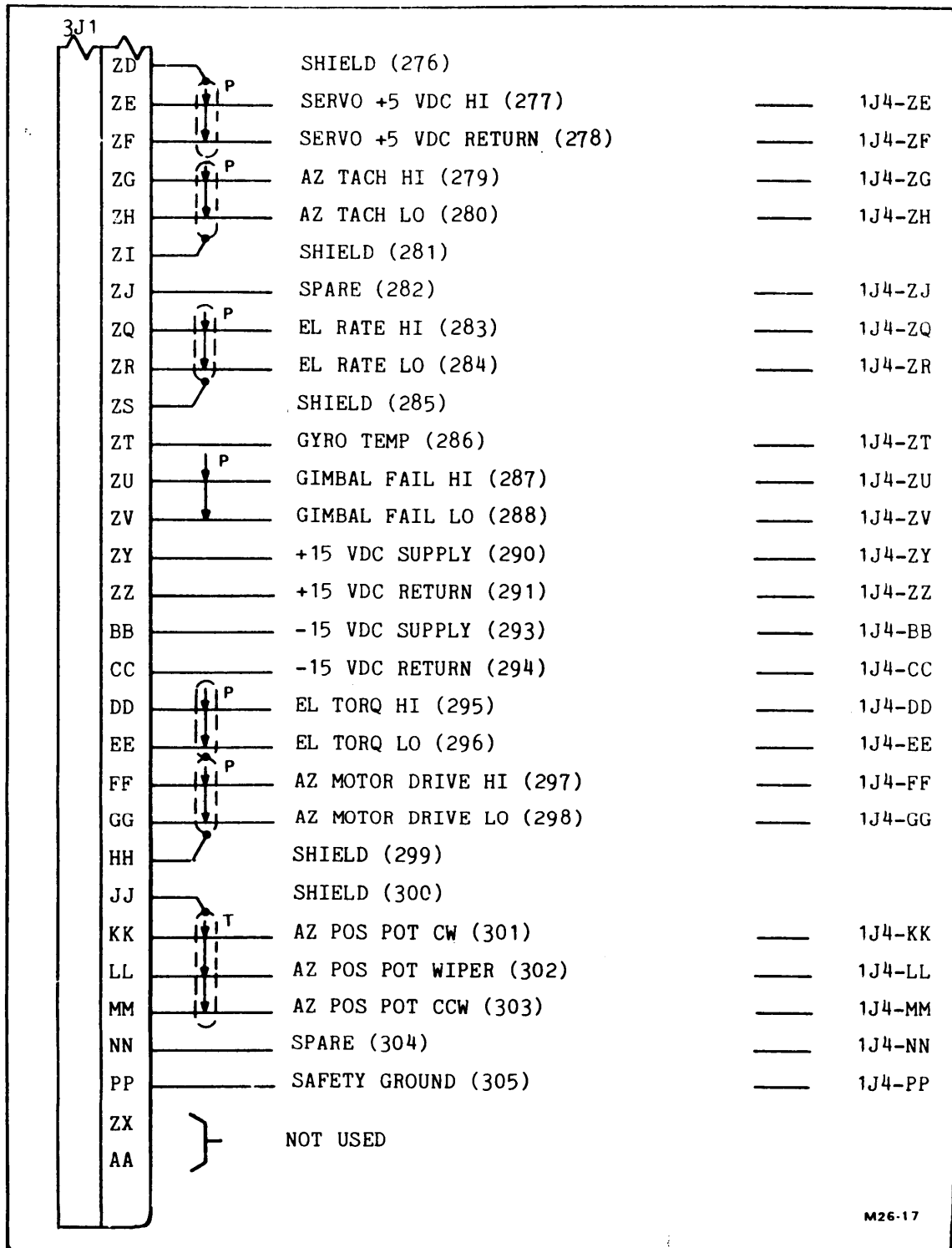

FIGURE 26. IRDS interconnecting diagram. (sheet 17 of 27)

MIL-HDBK-258(AS)

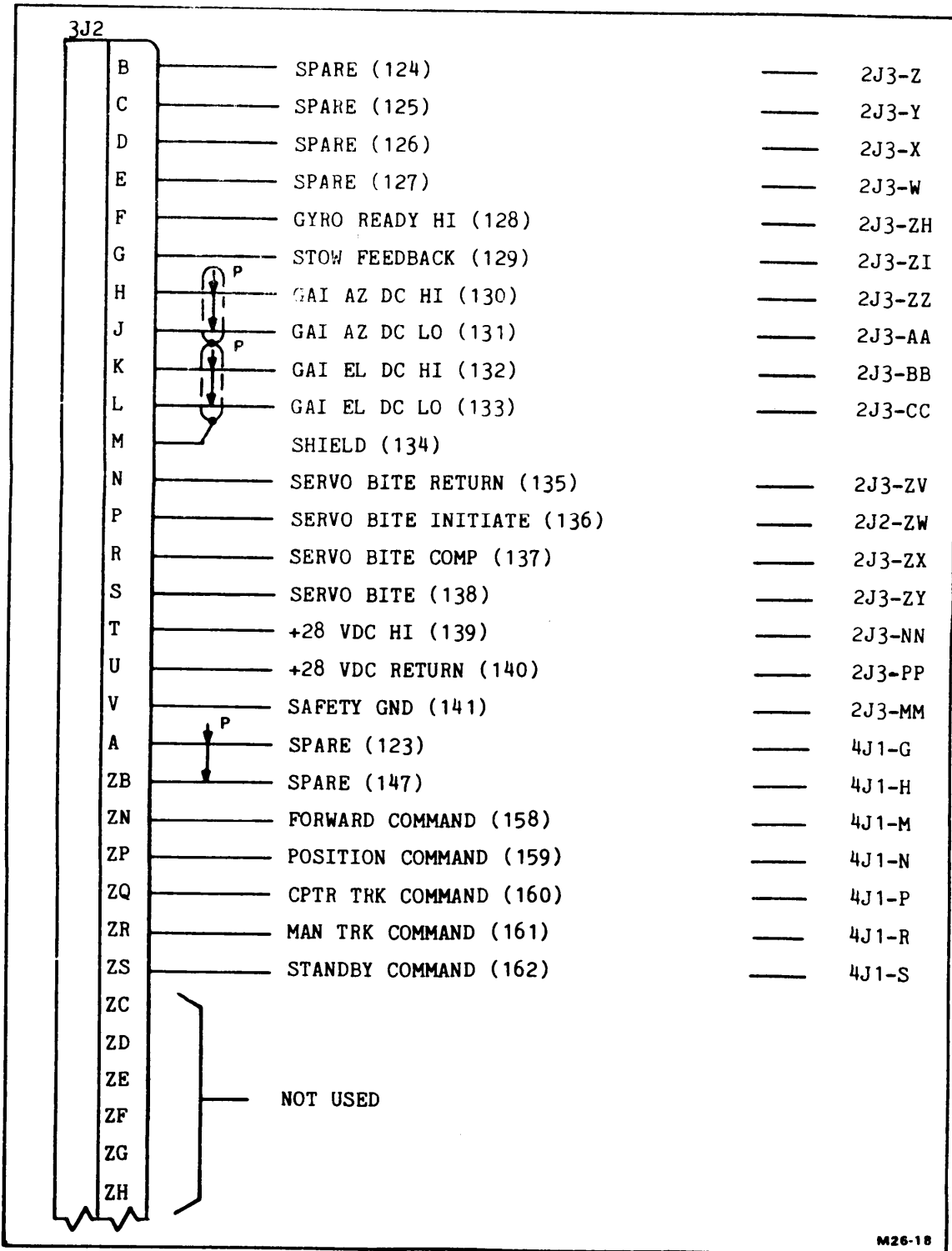

FIGURE 26. IRDS interconnecting diagram. (sheet 18 of 27)

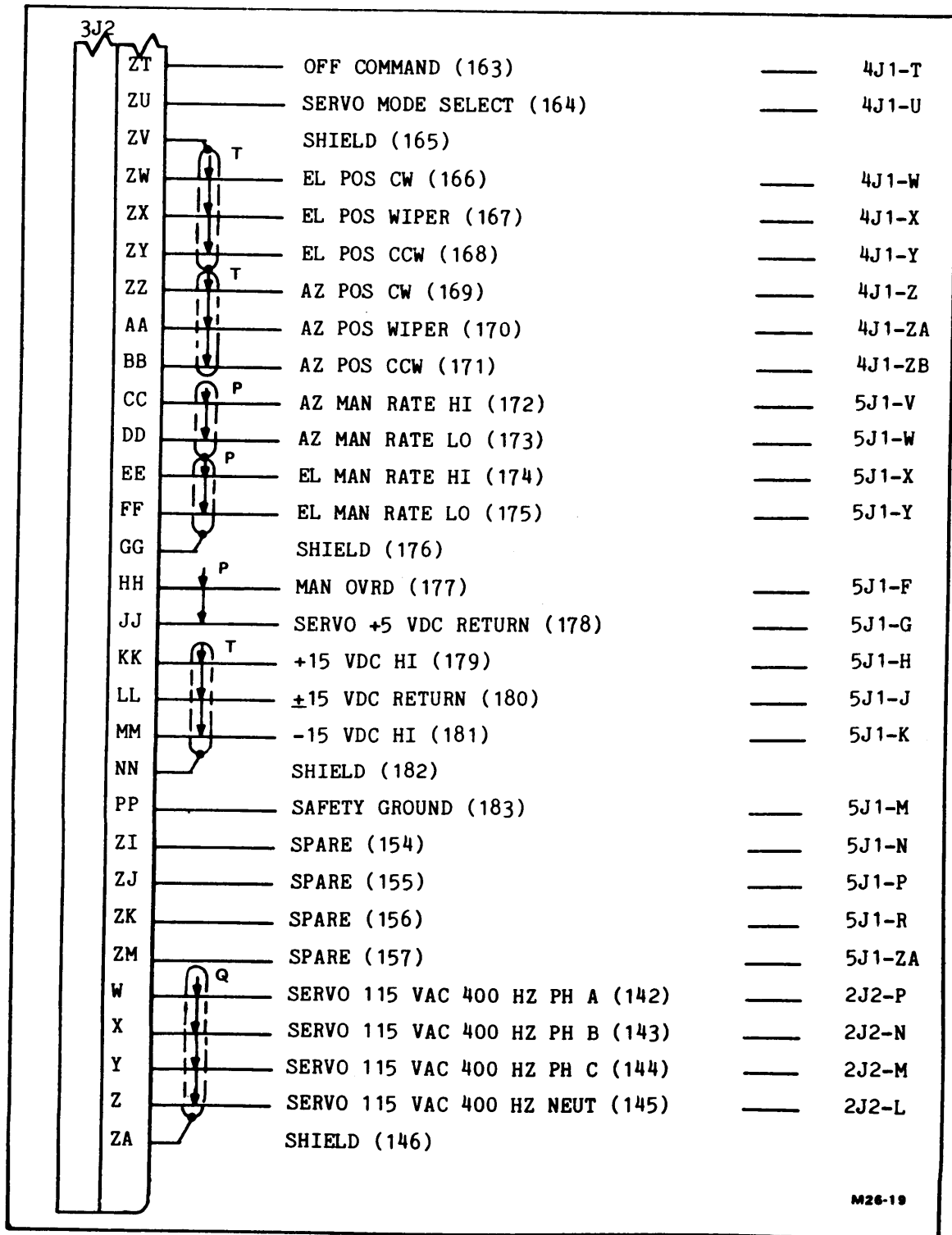

FIGURE 26. IRDS interconnecting diagram. (sheet 19 of 27)

MIL-HDBK-258 (AS)

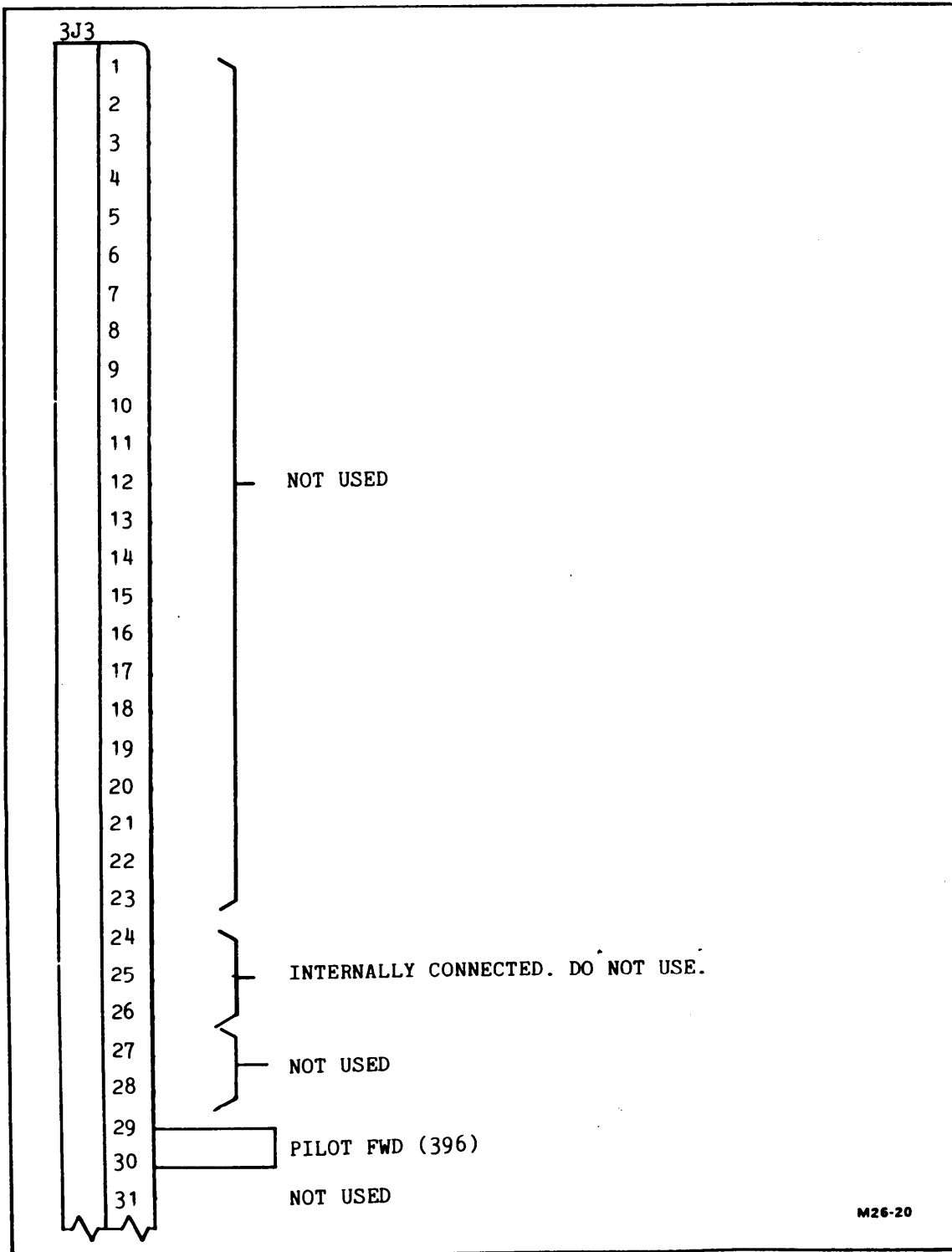

FIGURE 26. IRDS interconnecting diagram. (sheet 20 of 27)

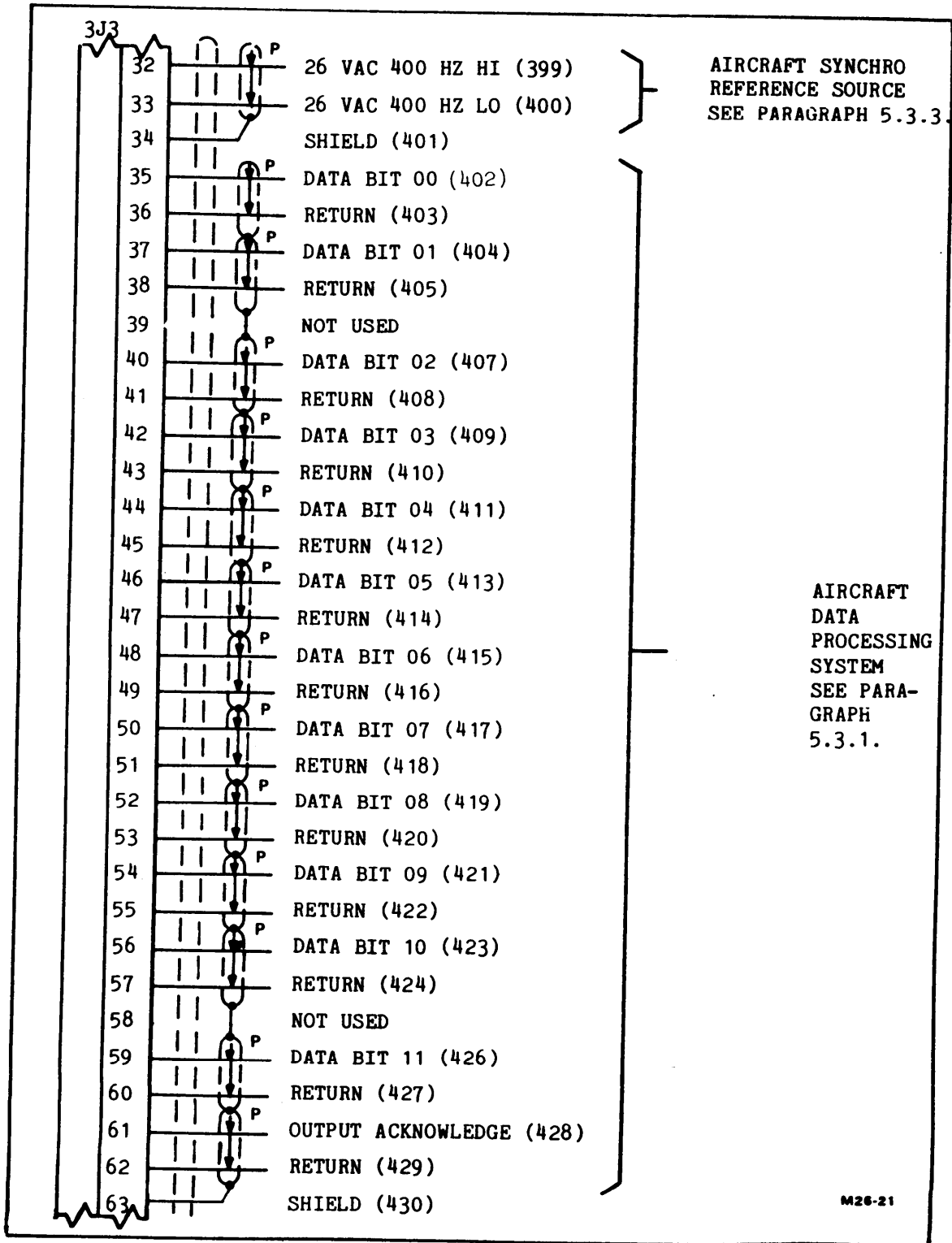

FIGURE 26. IRDS interconnecting diagram. (sheet 21 of 27)

MIL-HDBK-258 (AS)

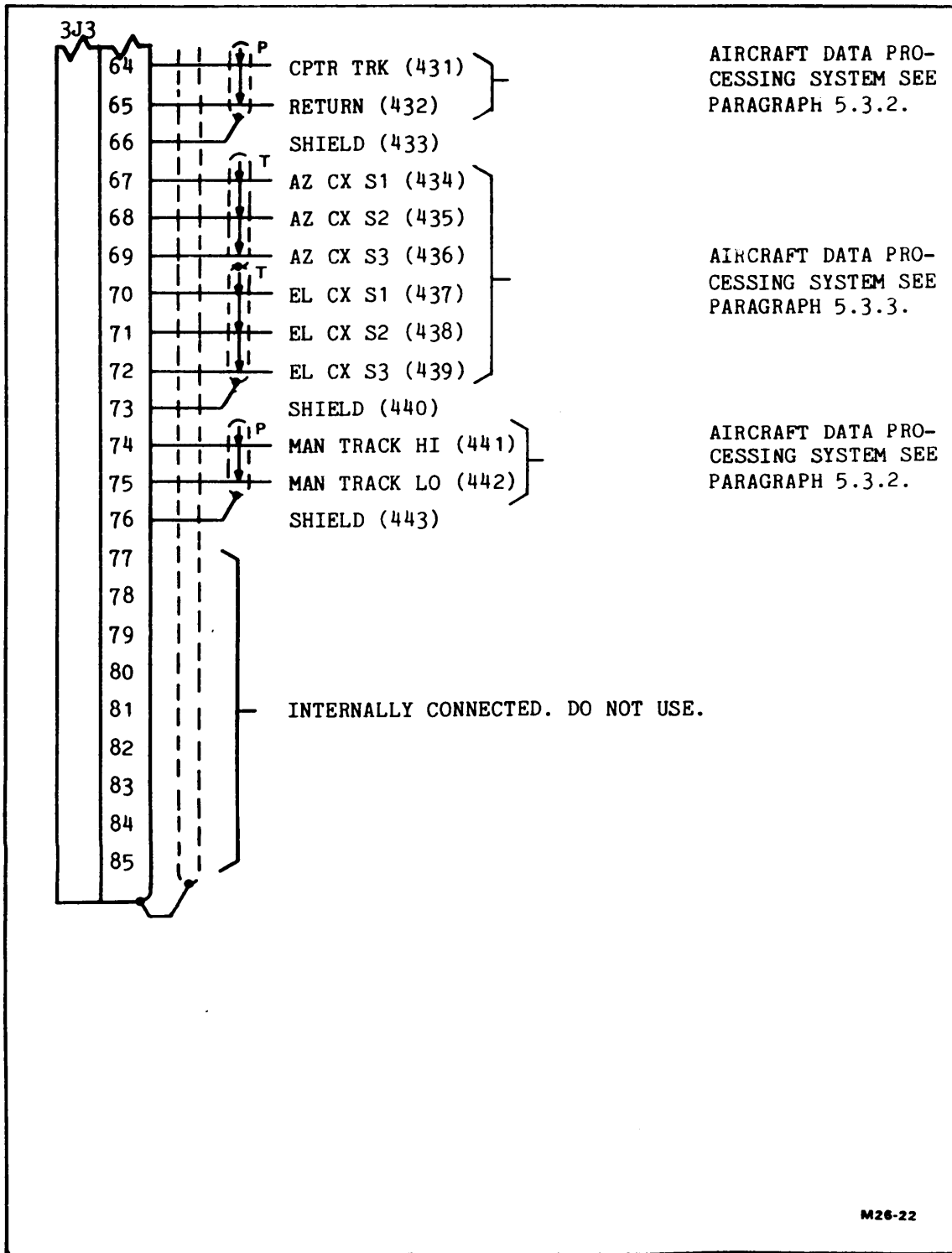
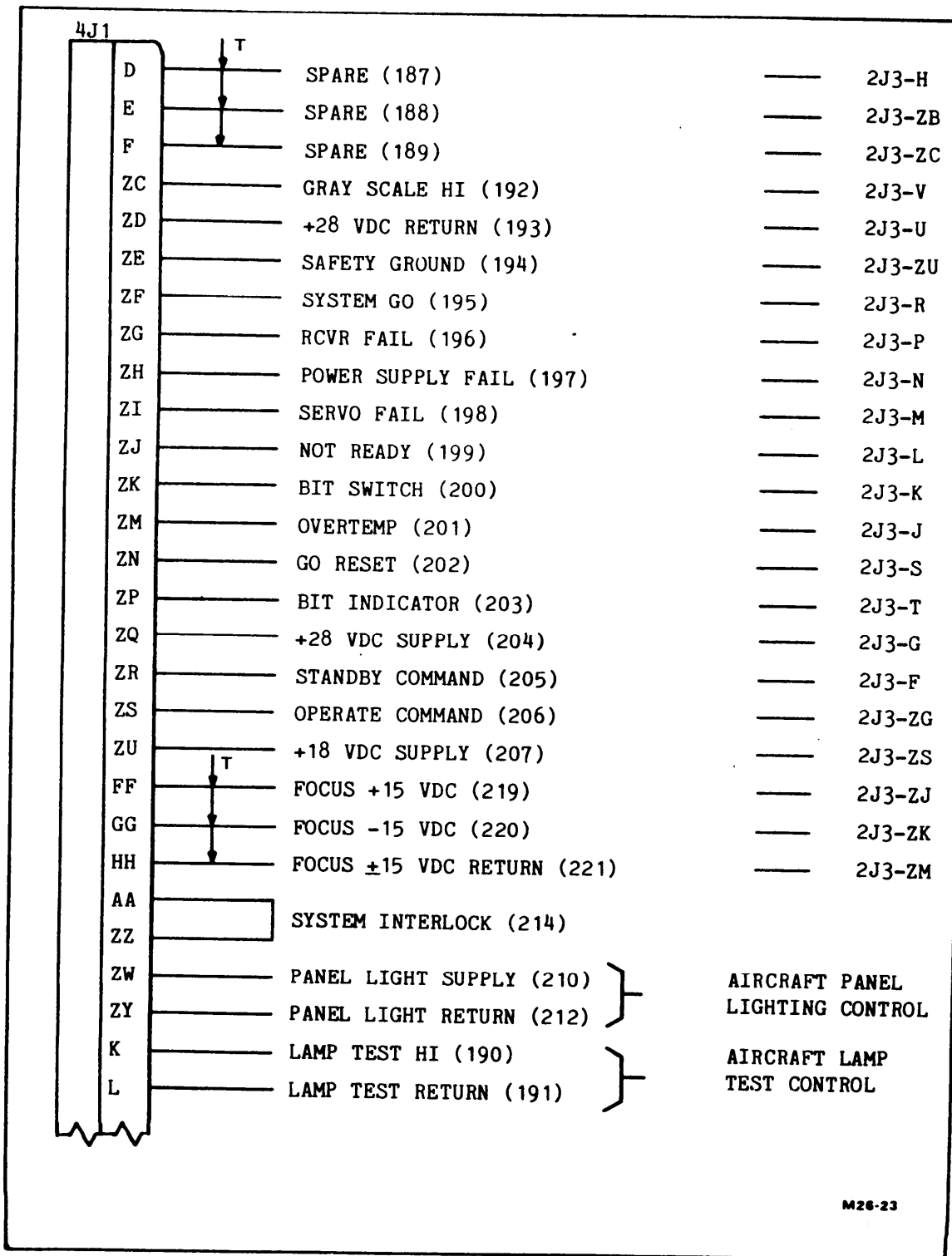

FIGURE 26. IRDS interconnecting diagram. (sheet 22 of 27)



M26-23

FIGURE 26. IRDS interconnecting diagram. (sheet 23 of 27)

MIL-HDBK-258 (AS)

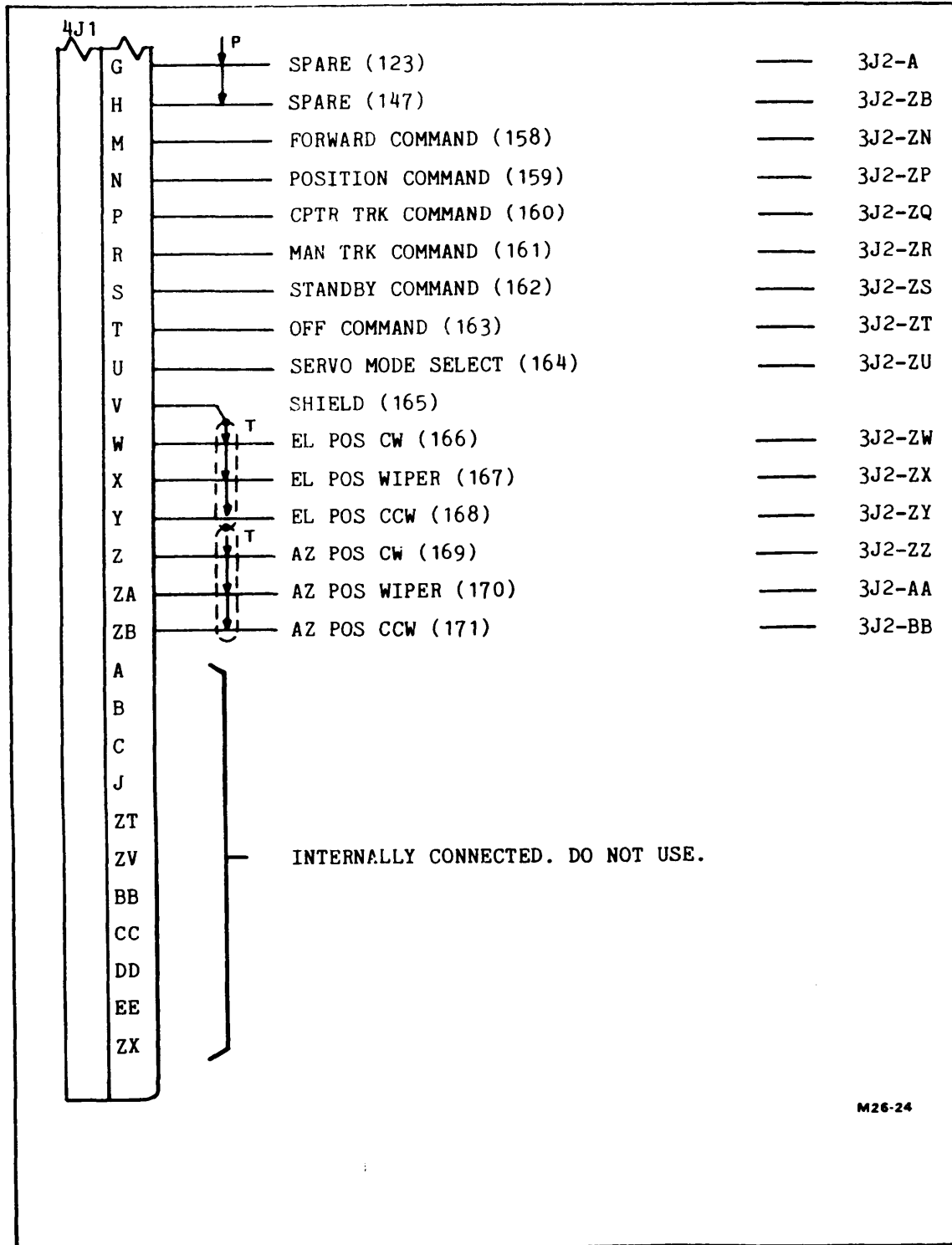
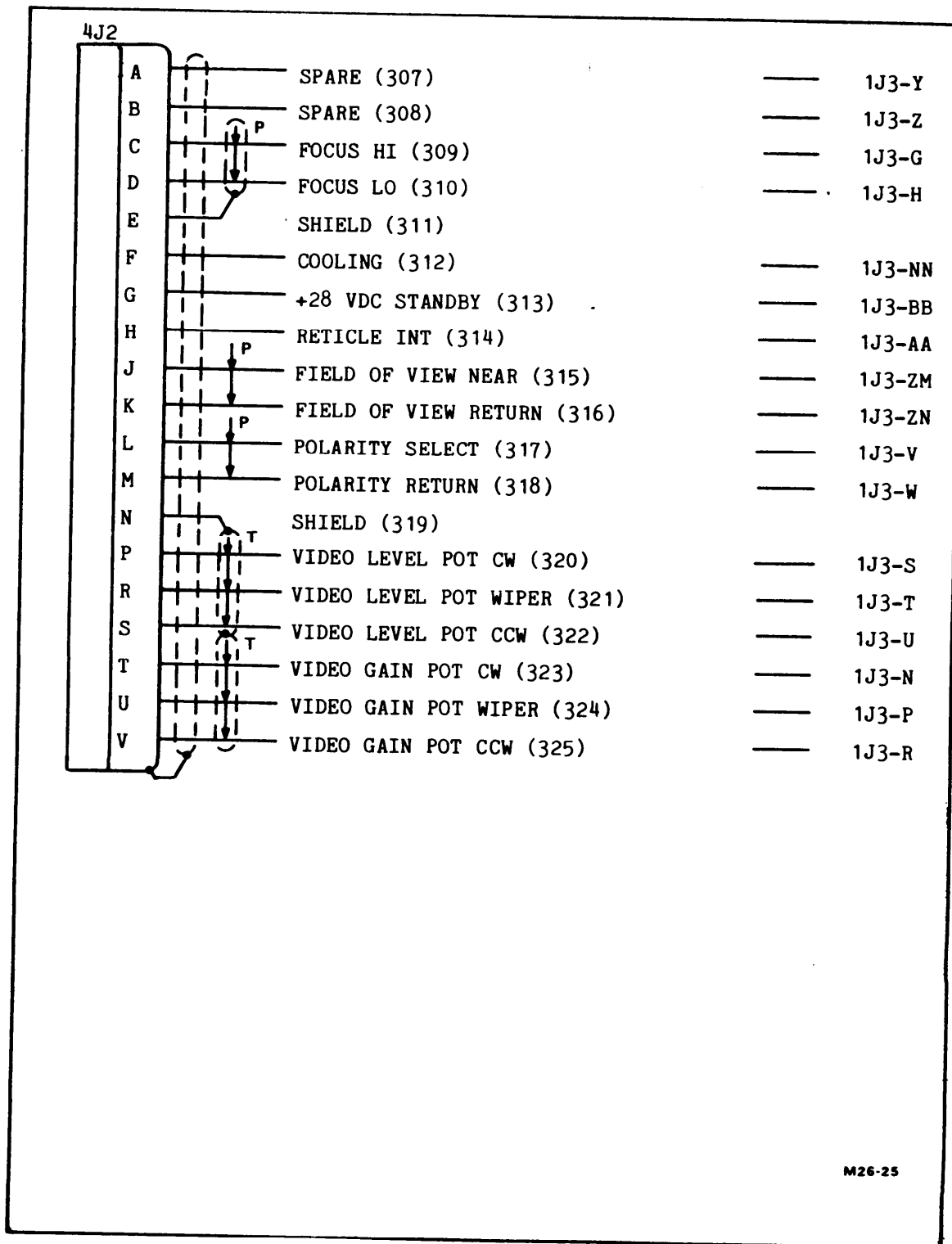

FIGURE 26. IRDS interconnecting diagram. (sheet 24 of 27)



M26-25

FIGURE 26. IRDS interconnecting diagram. (sheet 25 of 27)

MIL-HDBK-258 (AS)

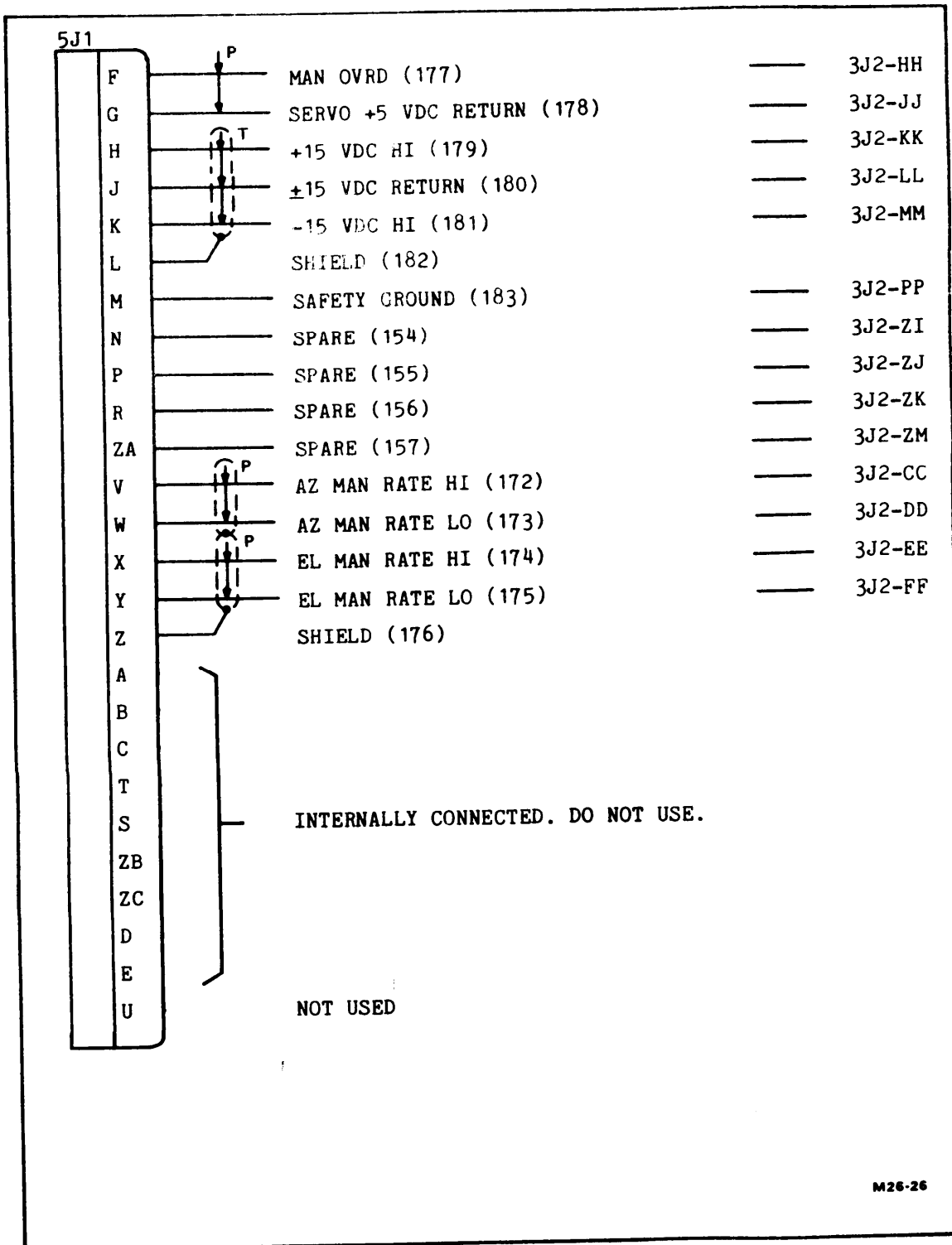

FIGURE 26. IRDS interconnecting diagram. (sheet 27 of 27)

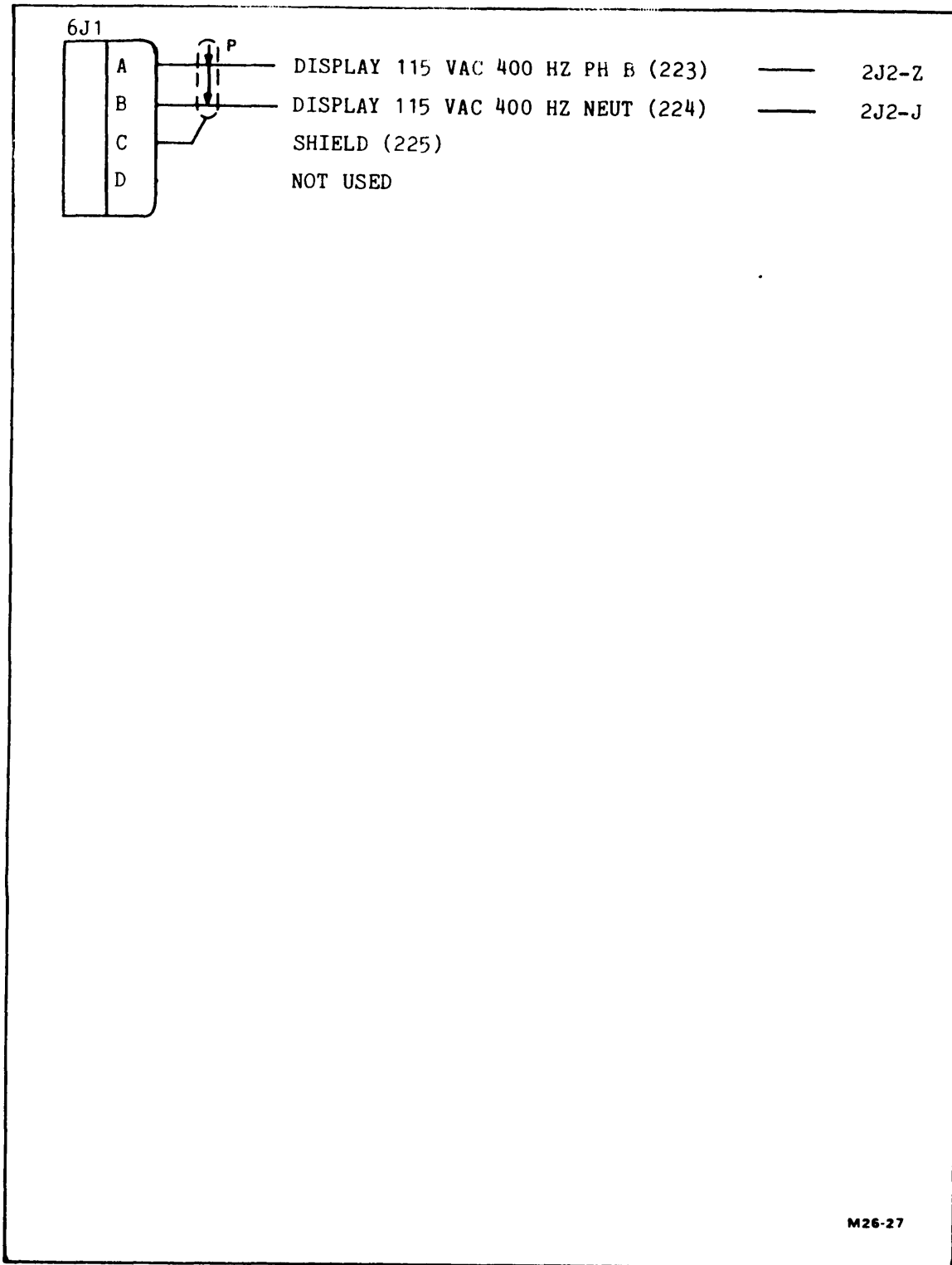

FIGURE 26. IRDS interconnecting diagram. (sheet 27 of 27)





FOLD

---

POSTAGE AND FEES PAID



**OFFICIAL BUSINESS**  
PENALTY FOR PRIVATE USE \$300

COMMANDING OFFICER  
Naval Air Engineering Center  
Engineering Specifications and Standards  
Department (ESSD) Code 93  
Lakehurst, N. J. 08733

---

FOLD

INCH-POUND

NOTICE  
OF VALIDATION

MIL-HDBK-258(AS)  
NOTICE 1  
24 October 1991

MILITARY HANDBOOK  
INTERFACE CONTROL DOCUMENT  
FOR INFRARED DETECTING SET AN/AAS-36

MIL-HDBK-258(AS), dated 3 August 1979, has been reviewed and determined to be valid for use in acquisition.

Preparing activity:  
Navy - AS

AMSC N/A

FSC 5855

DISTRIBUTION STATEMENT A. Approved for public release; distribution is unlimited.

