

MIL-HDBK-201B
23 Sept. 1971
SUPERSEDING
MIL-HDBK-201A
12 May 1961

MILITARY STANDARDIZATION HANDBOOK

PETROLEUM OPERATIONS



MIL-HDBK-201B

**OFFICE OF THE ASSISTANT SECRETARY OF DEFENSE
Washington, D. C. 20301**

**MILITARY HANDBOOK FOR PETROLEUM OPERATIONS
MIL-HDBK-201B**

1. This handbook has been approved by the Department of Defense and is for use by the Departments of the Army, the Navy, and the Air Force.
2. Recommended corrections, additions, or deletions should be addressed to the Defense Fuel Supply Center, Cameron Station, Alexandria, Virginia 22314. Copies of this handbook can be obtained through regular channels from the Commanding Officer, Naval Publications and Forms Center, 5801 Tabor Avenue, Philadelphia, Pennsylvania 19120.

CONTENTS

CHAPTER 1	GENERAL
1.1	PURPOSE
1.2	SCOPE
1.3	BASIC CONSIDERATIONS
CHAPTER 2	PROPERTIES, CHARACTERISTICS AND USES OF MILITARY FUELS AND LUBRICANTS
SECTION I	INTRODUCTION
2.1	GENERAL
2.2	TEST METHODS AND THEIR SIGNIFICANCE
2.3	PRINCIPAL PRODUCTS
SECTION II	FUELS
2.4	FUEL OIL BURNER a. General b. Types and Grades c. Properties and Characteristics
2.5	FUEL OIL DIESEL a. General b. Types and Grades c. Properties and Characteristics
2.6	FUEL, NAVY DISTILLATE a. General
2.7	KEROSENE a. General b. Types and Grades c. Properties and Characteristics
2.8	MOTOR GASOLINE a. General b. Types and Grades c. Properties and Characteristics
2.9	AVIATION GASOLINES a. General b. Types and Grades c. Properties and Characteristics
2.10	JET FUELS a. General b. Types and Grades c. Properties and Characteristics

MIL-HDBK-201B
23 September 1971

SECTION III LUBRICATING OILS

- 2.11 LUBRICATING OILS (ENGINES)
 - a. General
 - b. Types and Grades
 - c. Physical Properties and Characteristics

SECTION IV GREASES

- 2.12 GREASES
 - a. General
 - b. Types and Grades
 - c. Physical Properties and Characteristics

SECTION V RELATED COMPOUNDS

- 2.13 RELATED COMPOUNDS
 - a. General

CHAPTER 3 QUALITY SURVEILLANCE OF PETROLEUM AND RELATED PRODUCTS

SECTION I INTRODUCTION

- 3.1 GENERAL

SECTION II QUALITY SURVEILLANCE

- 3.2 GENERAL
- 3.3 TESTS AND METHODS
- 3.4 ROUTINE TESTS ON BULK PETROLEUM PRODUCTS
- 3.5 PACKAGED PETROLEUM PRODUCTS

SECTION III UTILIZATION OF OFF-SPECIFICATION PRODUCT

- 3.6 GENERAL

SECTION IV EFFECT OF METALS AND METAL COMPOUNDS ON PETROLEUM PRODUCTS

- 3.7 GENERAL
 - a. Zinc and Cadmium
 - b. Copper and Copper Bearing Metals
 - c. Aluminum

CHAPTER 4 TANK FARM OPERATIONS

SECTION I INTRODUCTION

- 4.1 GENERAL

SECTION II STORAGE TANKS

- 4.2 GENERAL
- 4.3 TYPES
 - a. Steel Tanks

MIL-HDBK-201B
23 September 1971

- b. Concrete Tanks
- c. Collapsible Tanks
- d. Miscellaneous Tanks

- 4.4 TANK ACCESSORIES
 - a. Vents
 - b. Breather Valves
 - c. Flame Arrestors
 - d. Tank Outlets
 - e. Gage and Thief Hatches
 - f. Oil Heaters
 - g. Pump and Pump Manifolds
 - h. Gage Tables

SECTION III PIPELINES (INTRA-TERMINAL)

- 4.5 GENERAL
- 4.6 TYPES
- 4.7 PIPELINE ACCESSORIES
 - a. Pipe
 - b. Valves
 - c. Expansion Joints
 - d. Blocks and Blinds
 - e. Pressure Relief Systems
 - f. Sediment Strainers and Sand Traps
 - g. Line Identification
- 4.8 PIPELINE TRANSFERS
 - a. Precleaning
 - b. Maintaining Product Quality
 - c. Flow Characteristics
 - d. Optimum Pumping Temperatures
 - e. Heating of Pipelines
 - f. Displacing and Filling Lines
 - g. Multiproduct Lines
 - h. Surge Pressures
- 4.9 GENERAL PIPELINE OPERATING RULES
- 4.10 SERVICING VALVES AND FITTINGS

SECTION IV PUMPING OPERATIONS

- 4.11 GENERAL
- 4.12 CENTRIFUGAL PUMPS
- 4.13 RECIPROCATING PUMPS
- 4.14 ROTARY PUMPS
- 4.15 PRIME MOVERS
- 4.16 HAZARD OF SHUTTING DOWN WHEN STATIC HEAD EXCEEDS
ALLOWABLE SHIP PRESSURE

MIL-HDBK-201B
23 September 1971

- 4.17 OPERATION OF VARIABLE SPEED PUMPS
- 4.18 PUMP SERVICING
- 4.19 SAFETY RULES AND PRECAUTIONS PERTAINING TO PUMPING AND PUMPHOUSE OPERATIONS

SECTION V TANK TRUCK AND TANK CAR OPERATIONS

- 4.20 GENERAL
- 4.21 TANK CAR AND TANK TRUCK EQUIPMENT
 - a. Preloading Inspections
 - b. Cleaning Compartments
 - c. Loading
 - d. Inspection after Loading
 - e. Quantity and Quality Checking Before Unloading
 - f. Unloading Precautions

SECTION VI TANKER OPERATIONS

- 4.22 GENERAL
 - a. Receiving Operations
 - b. Issuing

SECTION VI STORAGE

- 4.23 GENERAL
- 4.24 TRANSFERS
- 4.25 CIRCULATION
- 4.26 WATER DRAW-OFF
- 4.27 CHANGING TANK SERVICE

SECTION VIII PACKAGED PRODUCTS

- 4.28 GENERAL
- 4.29 RECLAMATION
- 4.30 DRUM AND CAN FILLING
- 4.31 STORAGE OF PACKAGED PRODUCTS
 - a. General
 - b. Site Selection
 - c. Storage of 55-gallon Drummed Petroleum Products
 - d. Storage of Products in 5-gallon Military Gasoline Containers
 - e. Storage of Packaged Lubricants and Greases
 - f. Water in Packaged Petroleum Products
- 4.32 STORAGE OF EMPTY CONTAINERS
 - a. General

SECTION IX PRODUCT MEASUREMENT AND SAMPLING

- 4.33 GENERAL

- a. Product Measurement
- b. Product Sampling

SECTION X HYDRANT FUELING SYSTEM

- 4.34 GENERAL
- 4.35 GENERAL EQUIPMENT AND FACILITIES
 - a. Tanks
 - b. Turbine Type Pumps
 - c. Water Separators
 - d. Fueling Control Valve
 - e. Defueling Control Valve
 - f. Defueling Pump
 - g. Liquid Level Control Valve
- 4.36 OPERATION

CHAPTER 5 PIPELINES

SECTION I INTRODUCTION

- 5.1 GENERAL
- 5.2 INTRA-TERMINAL PIPELINE SYSTEMS
- 5.3 INTER-TERMINAL PIPELINE SYSTEMS

SECTION II COMMON CHARACTERISTICS OF PIPELINE EQUIPMENT

- 5.4 GENERAL
- 5.5 PRINCIPLES OF OPERATION AND MAINTENANCE

SECTION III INTRA-TERMINAL PIPELINE SYSTEMS

- 5.6 GENERAL

SECTION IV INTER-TERMINAL PIPELINE SYSTEMS

- 5.7 GENERAL
- 5.8 PIPELINE COMMUNICATIONS
- 5.9 OPERATIONAL CONTROL OF THE SYSTEM
 - a. Scheduling
 - b. Records
- 5.10 PROCEDURES FOR DELIVERY TO PIPELINES
 - a. Single Product Delivery
 - b. Batching Two or More Products
- 5.11 PROCEDURES FOR RECEIVING FROM PIPELINES
- 5.12 OPERATING REPORTS
- 5.13 FLOW MANAGEMENT
 - a. General
 - b. Identification of Lines and Valves

MIL-HDBK-201B
23 September 1971

- 5.14 PIPELINE PATROLS
- 5.15 PIPELINE MAINTENANCE
- 5.16 PIPELINE REPAIRS
- 5.17 PIPELINE CLEANING

CHAPTER 6 TANK FARM OPERATIONAL MAINTENANCE

SECTION I INTRODUCTION

- 6.1 GENERAL
 - a. General Care of Facilities and Safety of Personnel
 - b. Equipment Records
 - c. Equipment Operations
 - d. General Safety Rules

SECTION II FACILITY INSPECTION

- 6.2 GENERAL
 - a. Inspection Responsibilities
 - b. Inspections Prior to Use
 - c. Operational Inspections
 - d. Periodic Tests and Inspections
 - e. Fire Protection Facilities

SECTION III TANK FARM MAINTENANCE

- 6.3 GENERAL
- 6.4 MAINTENANCE SCHEDULES
 - a. Machine History (Equipment Maintenance)
 - b. Periodic Overhaul and Inspection
- 6.5 TANK MAINTENANCE
 - a. Tank Grades
 - b. Tank Painting
 - c. Water Bottoms
 - d. Tank Roof Leaks
 - e. Tank Ladders and Stairways
 - f. Tank Grounding
 - g. Concrete Tanks
 - h. Tank Linings
- 6.6 TANK FITTINGS
 - a. Vents
 - b. Flame Arrestors
 - c. Pressure and Vacuum Vent Valve Settings
 - d. Gage Hatch Covers
 - e. Foam Chamber
 - f. Swing Line Assemblies
 - g. Automatic Gages
 - h. Valves
 - i. Draw-Off Valves
- 6.7 CONSERVATION TYPE STORAGE TANKS

MIL-HDBK-201B
23 September 1971

- a. Conventional Floating Roof Tanks
- b. Cone Roof Tanks with Internal Floating Pans
- 6.8 TANK CLEANING
- 6.9 BUILDING AND YARD MAINTENANCE
 - a. Building Maintenance
 - b. Yard Maintenance
- 6.10 PUMP MAINTENANCE
 - a. Pump Piping
 - b. Pump Leaks
 - c. Alinement
 - d. Pump Grounding
 - e. Electrical
 - f. Safety
 - g. Performance
 - h. Suction Difficulties
 - i. Pump Testing
- 6.11 REPAIR AND OVERHAUL OF PUMPS
 - a. Stuffing Boxes and Packing
 - b. Mechanical Seals
 - c. Bearings
 - d. Misalinement
 - e. Centrifugal Pumps
 - f. Rotary and Gear Type Pumps
- 6.12 WATERFRONT MAINTENANCE INSPECTIONS
 - a. Cleanliness
 - b. Hose-handling Equipment
 - c. Bonding Cables
 - d. Hose Testing
 - e. Communications
 - f. Electrical Systems
 - g. Fire-fighting Gear
 - h. Cathodic Protection
- 6.13 BARGES AND TANKERS
 - a. Tank Cleaning and Gas Freeing
 - b. Corrosion of Vessel's Tanks
 - c. Preparation of Vessel's Tanks
- 6.14 PIPELINES
 - a. Plug Valve
 - b. Gate Valve
 - c. Pressure-relief Valve
- 6.15 TANK TRUCKS
 - a. Servicing
 - b. Overhaul
 - c. Special Precautions
- 6.16 TANK CARS
- 6.17 CHANGING PRODUCT SERVICE OF TANK TRUCKS AND TANK CARS

MIL-HDBK-201B
23 September 1971

- 6.18 LOADING RACK
 - a. Inspections
 - b. Repairs
- 6.19 BULK LUBRICATING OIL
 - a. Heating Coils
 - b. Cleaning Lines
 - c. Cleaning Lube Oil Tanks
 - d. Additional Precautions

SECTION IV CORROSION CONTROL AND CATHODIC PROTECTION

- 6.20 GENERAL
 - a. Corrosion from Products
 - b. Corrosion from Soil
- 6.21 PAINT, COATINGS, AND WRAPPINGS
- 6.22 CATHODIC PROTECTION
- 6.23 MAINTENANCE OF CATHODIC PROTECTION EQUIPMENT

CHAPTER 7 HAZARDS CONNECTED WITH PETROLEUM FUELS

- 7.1 GENERAL

SECTION I HYGIENIC (HEALTH) ASPECTS

- 7.2 FUEL OIL
- 7.3 DIESEL FUEL
- 7.4 KEROSENE
- 7.5 GASOLINE
- 7.6 JET FUELS
- 7.7 CONTAINERS
- 7.8 SAFETY PRECAUTIONS IN CLEANING TANKS

SECTION II FIRE PREVENTION AND FIRE EXTINGUISHMENT

- 7.9 GENERAL
- 7.10 FIRE AND EXPLOSION HAZARDS
 - a. Fuel Oil
 - b. Diesel Fuel
 - c. Kerosene
 - d. Gasoline
 - e. Jet Fuels
- 7.11 STATIC ELECTRICITY
 - a. The Generation of Static Electricity
 - b. The Prevention of Static Electricity
- 7.12 PETROLEUM FIRES
 - a. Types of Fires
 - b. Fire Designations

MIL-HDBK-201B
23 September 1971

- 7.13 FIRE PREVENTION
 - a. Fire Inspections
 - b. Special Instructions
 - c. Fire Drills
- 7.14 SAFETY IN FUEL HANDLING OPERATIONS
- 7.15 FIRE AND EXPLOSION PREVENTION
- 7.16 EXTINGUISHING PETROLEUM FIRES
 - a. Water and Water Fog
 - b. Blankets
 - c. Foam
 - d. First Aid Fire Appliances
 - e. Carbon-dioxide Extinguisher
 - f. Soda-Acid Extinguisher
 - g. Dry-chemical Extinguisher
- 7.17 SAFETY PRECAUTIONS FOR LOADING JET FUEL AND KEROSENE
- 7.18 SAFETY PRECAUTIONS IN HEATING WASTE OIL

CHAPTER 8

CONSERVATION OF PETROLEUM PRODUCTS

- 8.1 GENERAL
- 8.2 ACCURACY OF PRODUCT MEASUREMENT
 - a. Calibration
 - b. Gaging
 - c. Terminal Pipelines
 - d. Tank Trucks, Tank Cars and Transports
 - e. Meters
 - f. Effect of Marine Transportation Losses
 - g. Water Bottoms
- 8.3 INSPECTION AND MAINTENANCE
- 8.4 LOSS THROUGH THEFT
- 8.5 RECORDS
- 8.6 CONSERVATION AND STORAGE
- 8.7 EFFECT OF TANK REPAIR ON LOSSES
- 8.8 LOADING RACKS
- 8.9 EFFECTS OF LEAKS

FIGURES

- 1. Fixed cone roof with internal floating pan
- 2. Pressure-Vacuum tank vents
- 3. Impeller and volute of a centrifugal pump

MIL-HDBK-201B
23 September 1971

4. Internal gear rotary pump
5. External gear rotary pump
6. Bob and tape (innage gaging)
7. Bob and tape (outage gaging)

(The above Figures pertain to Chapter 4 and are listed in numerical order.)

TABLES

TABLE I	Guide for Preparation of Cargo Tanks
TABLE II	Conversion Chart for Tank Cars and Tank Trucks

APPENDICES

APPENDIX A	Definitions
APPENDIX B	Publications Pertaining to Petroleum and Petroleum Operations
APPENDIX C	Tank Capacity Diagram for Approximate Values

MIL-HDBK-201B
23 September 1971

CHAPTER 1. GENERAL

1.1 PURPOSE. This handbook is designed to provide general standards, procedures and principles for the operations and operational maintenance of military petroleum handling facilities.

It is also intended as a training guide for "on-the-job" training and indoctrination of new personnel. It is not intended to replace departmental regulations or operating instructions applicable to any specific type of facility.

1.2 SCOPE. The contents are limited to technical and operational procedural information of a general nature. Specific conditions or facilities may require some deviation from the procedures described. Because of the wide variations in petroleum facilities and problems in administration, operation, and maintenance, it is not feasible to give detailed instructions. Accounting and stock control procedures (other than for receipt, storage, and issue) are not included in this

publication. Details of petroleum utilization, use limits, structural design, maintenance, and major machinery repairs are likewise not included, but are covered in the publications and directives of the applicable military departments.

1.3 BASIC CONSIDERATIONS. It is of utmost importance that personnel responsible for handling petroleum products be thoroughly trained and highly competent. There is no foolproof equipment that will compensate for carelessness, indifference, or incompetence. Good housekeeping and maintenance practices and a quality surveillance program as outlined in MIL-HDBK-200, Quality Surveillance Handbook for Fuels, Lubricants and Related Products, are essential in maintaining the quality of petroleum products and in maximizing the delivery of clean, acceptable product to the ultimate user.

CHAPTER 2. PROPERTIES, CHARACTERISTICS AND USES OF MILITARY FUELS AND LUBRICANTS

SECTION I. INTRODUCTION

2.1 GENERAL.

The principal properties and the uses of petroleum fuels, lubricants, and related products are described briefly herein. Definitions of terms used to describe these properties may be found in the Appendix. A general knowledge of these properties as related to specific products will assist personnel in product identification and necessary safe handling procedures.

2.2 TEST METHODS AND THEIR SIGNIFICANCE.

Since it is essential to maintain and control the quality of the great variety of petroleum products in a supply system, it is necessary to subject the products to a number of tests at various stages of manufacture, storage and distribution. Tests may be of two

kinds: those designed to control the quality of the product and those giving an indication of its expected performance. The majority of test methods in use today in the United States have been standardized and published by the American Society for Testing Materials (ASTM Standards for Petroleum Products and Lubricants), which provides a considerable degree of uniformity. Standard test methods used by the Federal Government, including the military, are published in the Federal Test Method Standard No. 791. Where ASTM and FTMS 791 test methods are identical, the ASTM test methods are used and are referenced in Federal Government specifications. This handbook will not attempt to furnish all of the details on test methods and their significance, however, it is recommended that those who are interested in such details obtain a copy of the Army Technical Manual RM 10-1165 entitled "Significance of ASTM Tests for Petroleum Products".

MIL-HDBK-201B
23 September 1971

2.3 PRINCIPAL PRODUCTS.

The principal products to be received, stored, and issued at military installations include Navy Special Fuel Oil (NSFO), Navy Distillate Fuel, Burner Fuels, Diesel Fuels, Kerosene, Aviation and Automotive Gasolines, Jet Fuels, Lubricating Oils, Greases, and other related products. Specifications for these products are listed in the Defense Fuel Supply Center's "Reference List of Specifications and Standards for

Petroleum and Related Products". For exact specification requirements and values, refer to the latest revision of the applicable specifications and to MIL-HDBK-200, Quality Surveillance Handbook for Fuels, Lubricants and Related Products. MIL-HDBK-200 sets forth general instructions and minimum procedures to be utilized in the quality surveillance of U.S. Government owned fuels and lubricants and related products world-wide.

SECTION II. FUELS

2.4 FUEL OIL, BURNER.

a. *General.* Fuel oils described herein are other than those used primarily for internal combustion engines. Shipping and handling of fuel oils requires as much attention as the more highly refined petroleum products to insure they are delivered at destination in good clean condition. Fuels in general use are of the following types

- (1) distillate, both cracked and straight run,
- (2) residual, cracked and straight run,
- (3) blends of the preceding types.

b. *Types and Grades.*

1. *Fuel Oil, Burner, MIL-1 59.*

(a) *General.* One grade of burner fuel, Navy Special is intended for use in steam powered vessels of the Navy and in other Government vessels as required.

2. *Fuel Oil, Burner, Federal Spec. VV-F-815.*

(a) *General.* This type of fuel oil is intended for use in oil-burner equipment for the generation of steam and for other purposes.

(b) This Federal Specification provides for six grades:

(1) *Grade No. 1.* A light distillate oil intended for use in burners of the vaporizing type in which the oil is converted to a vapor by contact with a heated surface or by radiation.

(2) *Grade No. 2.* A heavier distillate than grade No. 1. It is intended for

use in atomizing-type burners which spray the oil into a combustion chamber where the tiny droplets burn while in suspension.

(3) *Grade No. 4.* Usually a light residual but sometimes a heavy distillate. It is intended for use in burners equipped with devices that atomize oils of higher viscosity than domestic burners can handle. Its permissible viscosity range allows it to be pumped and atomized at relatively low storage temperatures. Thus, except in extremely cold weather, it requires no preheating for handling.

(4) *Grade No. 5 (Light).* A residual fuel of intermediate viscosity for burners capable of handling fuel more viscous than grade No. 4 without preheating. Preheating may be necessary in some types of equipment for burning and in colder climates for handling.

(5) *Grade No. 5 (Heavy).* A residual fuel more viscous than grade No. 5 (Light). It is intended for similar service. Preheating may be necessary in some types of equipment for burning and in colder climates for handling.

(6) *Grade No. 6.* A high viscosity oil, sometimes referred to as "Bunker C", and used mostly in commercial and industrial heating. It requires preheating in the storage tank to permit pumping and additional preheating at

MIL-HDBK-201B
23 September 1971

the burner to permit atomizing. The extra equipment and maintenance required to handle this fuel usually preclude its use in small installations.

c. *Properties and Characteristics.* The most important properties of burner fuel oils from standpoint of operation are viscosity, flash point, stability, compatibility, water and sediment, and flammability.

1. *Viscosity.* Viscosity is more significant for the heavier grades of fuel oils than it is for the lighter grades. Limits are generally set to help maintain uniform fuel flow in appliances with gravity flow, or to provide satisfactory atomization in small nozzles of household heating burners. Some burners are dependent on the fuel for lubrication, therefore a minimum viscosity is specified. With the heavier grades, preheating is generally required to control its viscosity in order to provide good atomization in a given type of burner. In addition, it is equally important that the maximum viscosity under the existing conditions of temperature and pressure be such that the oil can be pumped satisfactorily from the storage tank to the preheater. Navy Special is a relatively free flowing liquid which can be stored and transferred in mild climates with little or no heating.
2. *Flash Point.* Relatively high flash points are desirable for safe handling and use of burner fuel oils. The minimum permissible flash point is usually set by various regulatory bodies and is based on accepted practice in handling and use. It may also be used to detect contamination as a substantially lower flash point is a reliable indicator that a product has become contaminated with a more volatile product, such as gasoline.
3. *Stability.* Most fuel oils obtained by simple distillation of crude oil are as stable as the crude oil from which they are derived. When cracked fuel oils first came into general use, troubles from thermal instability soon developed. The most serious effect is the formation of adherent deposits in oil heaters. The cracked oils, having had their molecular

structure drastically rearranged in the cracking process, continue to undergo slow chemical change after they have cooled, this change is accelerated by heating. This problem arises particularly where the fuel has to be stored for some time, and various tests have been devised for examining oil of this nature.

4. *Compatibility.* Since approved Navy Special fuel oils are compatible with one another, they should not be blended with diesel fuels or other products, and should be stored in tanks which are reserved only for this product. The stability and compatibility may be seriously affected by admixing with diesel fuels, especially those diesel fuels composed of highly paraffinic stocks, and may cause formation of heavy deposits in the oil preheaters or sludging in the fuel storage tanks. Contamination of diesel fuel oil by boiler fuel oil is even more serious and cannot be tolerated. Separate piping must be used for these two products to avoid such contamination.
5. *Water and Sediment.* For distillate fuel oils there should be no problem involving contaminants such as water and sediment. The heavier grades of residual fuel will usually contain a measurable amount of one or both due to the nature of the product and conditions of storage. Any appreciable amount of sediment results in strainer blockage, fouling of burner tips, lines, etc., and may cause deposition of soot, formation of smoke, etc. Excessive water content, caused by careless handling, accident, or during marine shipment, is objectionable because of foaming in storage tanks where heating to relatively high temperatures is necessary for viscosity reduction. The water may vary from "free" water which will settle out if given sufficient time, to stable emulsions which will not settle out.
6. *Flammability.* Because of their relatively high flash points, burner fuel oils are not flammable at ordinary temperatures. When fuel oil is stored at a temperature well below its flash point, its vapor, though combustible in nature, is too diluted to ignite or burn. In other words, the vapor-air mixture in a tank of fuel oil at a temperature sufficiently

MIL-HDBK-201B
23 September 1971

under its flash point is below the lower limit of explosibility. A difference in temperature of 15°F under the flash point will usually provide the needed safety factor. However, to maintain this degree of safety, maximum precautions should be taken to avoid mixing volatile fuels such as gasoline, kerosene, etc. with burner fuels.

2.5 FUEL OIL, DIESEL.

a. General.

1. Diesel fuels are used in compression ignition engines in which air enters the engine at atmospheric pressure or is forced in under higher pressures by a pump or blower. The engine develops power by internal combustion in the same way as a gasoline engine, but differs in the way the fuel is ignited. In a gasoline engine, gasoline is mixed with fresh air in a carburetor and ignited in the cylinder by an electric spark. In a diesel engine, fuel is injected into a combustion space through an injection nozzle which breaks up the fuel into a fine spray and fuel vapor which is ignited by the heat of the air in the cylinder. The air obtains its heat as a result of being compressed by the piston.
2. Diesel fuels are used to operate compression ignition engines in submarines, destroyer escorts, landing craft, auxiliary equipment aboard larger craft as well as buses, heavy trucks, tractors, railroad diesel locomotives, stationary plants, and in other auxiliary units.

b. Types and Grades

1. Federal Specification VV-F-800, Fuel Oil, Diesel

- (a) *Grade DF-A (Arctic)*. This grade is intended for use in high speed automotive type diesel engines and in pot type burner space heaters, in areas where mean ambient temperatures lower than minus 25°F occur, and where it is impractical to obtain or store both diesel and burner fuels. It should not be used for slow-speed stationary engines.
- (b) *Grade DF-1 (Winter)*. This grade is intended for use in high speed automotive

service in areas in which ambient temperatures as low as minus 25°F occur. It may be used for medium-speed stationary engine applications, where fuel heating facilities are not available.

- (c) *Grade DF-2 (Regular)*. This grade is intended for use in all automotive high-speed diesel engines and in medium-speed applications in areas in which the ambient temperatures are above 0°F.

2. MIL-F-16884 Fuel Oil, Diesel

- (a) This specification covers a marine diesel fuel oil suitable for use in compression ignition engines in submarines and ship-board operations at all temperatures above 10°F.
- c. *Properties and Characteristics*. The most important properties are flash point, viscosity, pour point, cloud point, and its cleanliness (water, sediment, and ash contents), ignition quality, volatility, distillation and sulfur content. The properties of fuel oils having considerable influence on the performance and reliability of a diesel engine are summarized as follows:
 1. *Flash Point*. A fuel having an excessively low flash point is dangerous in storage and handling.
 2. *Viscosity*. Lubrication of the parts in the fuel injection system depends entirely upon the fuel oil, and therefore its viscosity cannot be below a certain minimum value.
 3. *Pour Point*. This is of particular importance for cold-starting an engine, and for handling an oil between storage and engine. A diesel fuel does not ordinarily have to be heated before use, but if the pour point is too high some warming of this product may be required.
 4. *Ash and Sediment*. Appreciable amounts tend to cause trouble in burner mechanisms.
 5. *Ignition Quality*. This property not only determines the ease of ignition and of starting cold-engines, but also the kind of combustion obtained from the fuel. The higher the cetane number, the easier the starting even at low temperatures, together with

MIL-HDBK-201B

23 September 1971

quicker warm-up, smoother and quieter operation, lower maximum cylinder pressures and more efficient combustion.

6. *Volatility*. In order to obtain low fuel consumption, low exhaust temperature, and minimum smoke, small diesel engines demand higher volatility than do heavier engines.
7. *Sulfur Content*. Low sulfur content is desirable to reduce corrosive effects of harmful acids.

2.6 FUEL, NAVY DISTILLATE.

- a. *General*. Navy Distillate (ND) fuel is one grade of distillate fuel intended for fleet use in designated marine power plants.

2.7 KEROSENE.

- a. *General*. Kerosene is used in space heating units, wick-fed lamps, bomb-type flares, wiping down certain machinery, cleaning tools, and as a vehicle for liquid insecticide sprays.
- b. *Types and Grades*. There is but one regular grade of kerosene carried in the military supply system. Federal Specification VV-K-211. (NOTE: Kerosene prepared for use as a vehicle for liquid insecticide sprays is a deodorized kerosene covered by Federal Specification VV-K-200).
- c. *Properties and characteristics*. The most important properties from standpoint of operation are burning qualities, distillation, and flash point.
 1. *Burning qualities*. Kerosene should burn with a steady, clear flame in wick lamps. When used in stoves, it should vaporize completely but not to the extent that it will form explosive mixtures with air.
 2. *Distillation*. A good grade of kerosene generally has a boiling range between 300 F and 572 F, so that there is an absence of heavy ends or extremely high boiling point fractions which interfere with clean burning in lamps or complete vaporization in stoves.
 3. *Flash Point*. The absence of light ends or very low boiling point fractions gives the

kerosene a relatively high flash point to secure safety in handling, storage, and burning.

2.8 MOTOR GASOLINE.

- a. *General*. Motor gasolines are used to fuel spark-ignition internal combustion engines which power motor vehicles, combat vehicles, portable auxiliary power plants, stationary units, and as a fuel in gasoline pressure appliances, such as field stoves, heating units, and blow torches. Automotive gasolines differ from aviation gasolines mainly in volatility, anti-knock, and vapor pressure properties. Because of these differences, the use of automotive gasoline in aircraft is unsafe. In the national effort to eliminate air pollutants, gasolines containing a maximum of 0.50 grams/gal. in lieu of 4.23 grams/gal. have been phased into the supply system. Low leaded or unleaded gasolines may be commingled with comparable leaded fuels in storage.
- b. *Types and Grades*
 1. *Federal Specification VV-G-76, Gasoline, Automotive*. This gasoline is furnished in REGULAR AND PREMIUM Grades, each of these grades is further classified as Class A through E in which volatility properties differ to make them suitable for use under various climatic temperature conditions. REGULAR grade gasoline is intended for general use in all motor vehicles, and gasoline-consuming stationary and marine power plants unless PREMIUM grade is specifically recommended by the equipment manufacturer.
 2. *Interim Federal Specification VV-G-001690(Army-MR), Gasoline, Automotive, Low Leaded or Unleaded*. This gasoline is similar to VV-G-76 except that the lead content is limited to a maximum of 0.5 grams/gal. In addition, a lower octane product designated as SPECIAL grade is provided for use in 1971 (or later) vehicles capable of operating on a reduced octane quality gasoline.
 3. *Federal Specification VV-G-109, Gasoline, Unleaded*. This is a low octane (62 ASTM motor octane minimum) grade of gasoline for use in some stationary internal-

MIL-HDBK-201B
23 September 1971

combustion spark-ignition engines, and as fuel in gasoline pressure appliances.

4. *Specification MIL-G-3056, Gasoline Automotive, Combat.* This gasoline is received in one grade, but in two types. To minimize multiple grades of gasolines in military supply systems outside continental United States, combat grade of gasoline is shipped into overseas areas.

Type I. General all-purpose gasoline intended for use in combat vehicles at all temperatures above 0°F.

Type II. A special low temperature all-purpose gasoline intended for use in combat vehicles in areas where the mean temperature is consistently below 32°F.

- c. *Properties and characteristics.* The most important properties from standpoint of operation are volatility, knock characteristics, lead content, gum content, and sulfur content.

1. *Volatility.* The volatility of gasoline is usually measured in terms of vapor pressure and distillation. The vapor pressure of a fuel is determined by the Reid Vapor Pressure Test and indicates the tendency of the fuel to vaporize. Vapor pressure increases with temperature for any given gasoline. Gasolines must have a certain vapor pressure to insure proper starting and accelerating qualities. Too high vapor pressure for the particular operating condition may cause what is commonly known as "vapor lock", which prevents the fuel from reaching the engine. The tendency of gasoline to vaporize in an automobile fuel system is indicated by the vapor-liquid ratio of that gasoline at conditions approximating those in critical parts of the fuel systems. This test is currently used at procurement levels in conjunction with Reid Vapor Pressure to determine vaporizing properties of automobile gasoline. The distillation test is a measure of the volatility of a product. The lower boiling fractions of gasoline indicate the starting ability of an engine at the given temperature and the engine's ability to warm up quickly when using that gasoline. An excessive amount of highly volatile constituents in gas-

oline may cause vapor lock; conversely, an excessive amount of "heavy ends" may not completely burn in the combustion chamber and consequently may cause damage through excessive crankcase dilution. Specifications designate minimum and maximum percentages to be evaporated at specified temperatures as well as initial and final boiling points of the product. A high-end point and a high percentage of residue may be indicative of contamination of gasoline with fuel oil or other oils.

2. *Knock Value.* The knock value is normally expressed as octane number for automotive type engine gasolines. This value is determined by actually comparing the knocking tendency of a fuel to laboratory standard test fuels of known knock value in a standard test engine. The significance of knock value is to indicate whether the fuel will tend to burn uniformly and evenly in a cylinder without preignition or detonation. Fuels of inadequate knock value will reduce power output in all types of engines, and if used for more than brief periods can cause overheating of the engine unit, burned pistons and cylinders, lubrication failure, and even piston and cylinder destruction.
3. *Lead Content.* The tendency of a gasoline to knock may be decreased by the addition of a very small amount of knock inhibitors; the most commonly used agent of this type is tetraethyllead.
4. *Gum Content.* The causes and effects of gum in gasoline are so complex as to prevent completely, adequate definition by means of laboratory test. Gasolines of all types generally have negligible gum contents when freshly manufactured. The fuel may be in storage under adverse climatic conditions before all of it is used, and unless it is properly blended and stabilized against slow oxidation, objectionable amounts of gum may form during storage. Gum specifications of military products are therefore more stringent than needed for normal civilian purposes, because long periods of storage under adverse conditions are more likely to occur during military operations than in ordinary commercial practice.

MIL-HD3K-201B
23 September 1971

5. *Sulfur Content.* It is important that gasoline be noncorrosive and remain so during service. During refinery processing, objectionable sulfur compounds are removed to the greatest extent possible. Each fuel specification generally prescribes maximum permissible level, as the products of combustion contain compounds that are corrosive or become corrosive in the presence of moisture. A variety of methods have been developed for ascertaining whether fuels have corrosive or potentially corrosive tendencies.

2.9 AVIATION GASOLINES.

- a. *General.* Aviation gasolines are used as fuel for the reciprocating piston type engines used in aircraft. These gasolines are not satisfactory for use in motor vehicles because of their low vapor pressures and distillation ranges, and high tetraethyllead content.
- b. *Types and Grades.*
1. *Specification MIL-F-5572.* There are three grades.
 - (a) 80/87 - dyed red
 - (b) 100/130 - dyed green
 - (c) 115/145 - dyed purple
- c. *Properties and Characteristics.* The properties of avgas are similar to those described for motor gasoline except the following:
1. *Volatility.* The volatility of aviation fuels is not varied deliberately from summer to winter like motor gasoline. The distillation range is the same the year around and the vapor pressure is always in the same range 5.5-7.0 pounds per square inch.
 2. *Tetraethyllead Content.* This anti-knock additive is added to a much higher degree than for motor fuels to increase anti-knock characteristics.
 3. *Anti-knock Characteristics.* In aviation fuels these characteristics are indicated by two numbers. The lower number, such as 100 in grade 100/130 gives the anti-knock rating of the fuel when used in a lean mixture such as when the aircraft is cruising. The higher number 130 gives the rich mixture rating of

the fuel which is required when the plane is taking off or under accelerated power conditions. Numbers above 100 are called performance numbers rather than octane numbers. For 130, the fuel is equivalent to a fuel having 130 percent of the anti-knock rating of iso-octane.

2.10 JET FUELS.

- a. *General.* Jet fuels are used in aircraft turbine engines, ramjet engines, rocket engines and other turbine powered equipment. These fuels are derived from petroleum as are gasolines but differ in that they do not contain tetraethyllead nor need any anti-knock characteristics. Because of these characteristics, jet fuels cannot be used in reciprocating type aircraft engines.
- b. *Types and Grades.*
1. *Specification MIL-T-5624.*
 - (a) *Grade JP-4.* Used in land based jet aircraft and other turbine powered equipment.
 - (b) *Grade JP-5.* Used in aircraft carrier type aircraft because of its high flash and fire safety characteristics. Also used in other turbines and as an alternate fuel for compression ignition equipment and ship-board boilers capable of burning Navy Distillate fuel.
- c. *Properties and Characteristics.* The most important properties are flash point (for JP-5 only), vapor pressure (for JP-4), sulfur content, freeze point, water reaction, thermal stability and cleanliness.
1. *Flash Point.* The JP-5 fuel must have a flash point of 140°F or greater in order to provide the safety factor required by aircraft carriers. JP-4 fuel will flash at temperatures as low as approximately minus 20°F and hence this fuel must be handled with caution from a safety standpoint.
 2. *Vapor Pressure.* Grade JP-4 jet engine fuel has a medium vapor pressure which is lower than that of aviation gasoline. Because of this characteristic, JP-4 grade jet fuel is dangerous to handle since flammable vapor-air mixtures are formed at ambient tempera-

MIL-HDBK-201B

23 September 1971

- tures in the space above the fuel. Grade JP-5 fuel does not have a vapor pressure requirement.
3. *Sulfur Content.* Same as for the fuel oils, diesel fuels and gasolines previously discussed.
 4. *Freeze Point.* These fuels must have freezing points of minus 72°F for JP-4 and minus 51°F or below for JP-5. Ice and wax crystals precipitated out of the fuel at extremely low temperatures encountered during flight at high altitudes could cause clogging of fuel screens, producing engine fuel starvation and flame out. To prevent any such occurrence a fuel system icing inhibitor (FSII) is added to JP-4 fuel at the time of manufacture. This additive acts to prevent ice formation in aircraft fuel systems. On occasions using military activities may inject FSII into the fuel in order to maintain the necessary level of FSII in the fuel.
 5. *Water Reaction.* Jet fuels must produce a sharp clean separation when mixed with water. This gives a good indication that the fuels are clean and will not plug screens in the engine fuel system.
 6. *Thermal Stability.* This property indicates the ability of the fuel to withstand the high temperatures encountered in the jet engine fuel system and in the systems used to absorb excess heat generated by the engine or by flight speed. Coke produced by thermally unstable fuels will plug engine fuel jets and manifolds causing engine hot spots and consequent engine malfunction.
 7. *Cleanliness.* Jet fuels have a greater affinity for water than reciprocating engine fuels. The settling of small solid particles is much slower in jet fuels than in reciprocating engine fuels. Jet fuels also tend to loosen rust and scale in storage tanks. These fuels are difficult to keep clean and extremely difficult to clean up once they become contaminated. Current specifications for JP-4 and JP-5 specify a maximum limit of 1.0 mg/liter of solid contaminants at the time of procurement to ensure fuel cleanliness. The consumption rate of jet fuel per engine hour is normally much greater than for a reciprocating engine, and jet engine fuel controls are generally more susceptible to malfunction from contamination than a reciprocating engine carburetor. For these reasons, it is imperative that close control be maintained over the quality of these fuels and the condition of the systems used in handling them.

SECTION III. LUBRICATING OILS

2.11 LUBRICATING OILS (ENGINE).

- a. *General.* Lubricating oils used in automotive engines and aircraft engines are either petroleum type oils or synthetic type oils. Automotive oils are derived from petroleum and are suitable for the lubrication of reciprocating internal combustion engines of both spark-ignition and compression-ignition type.

- b. *Types and Grades.*

1. *Lubricating Oil, Internal Combustion Engine, Tactical Service, MIL-L-2104.*

- (a) *General.* This specification covers one type of engine oil suitable for the crank-

case lubrication of reciprocating spark-ignition and compression-ignition engines used in all types of military tactical ground equipment and for the crankcase lubrication of high-speed, high-output, supercharged compression-ignition engines used in all ground equipment, when ambient temperatures are above minus 20°F.

- (b) Four grades of this oil are provided:

<u>Viscosity Grade</u>	<u>Military Symbol</u>
Grade 10	OE/HDO-10
Grade 30	OE/HDO-30
Grade 40	OE/HDO-40
Grade 50	OE/HDO-50

MIL-HDBK-201B
23 September 1971

2. *Lubricating Oil, Internal Combustion Engine, Administrative Service, MIL-L-46152.*

(a) *General.* This specification covers two types of engine oil suitable for the crankcase lubrication of commercial type vehicles used for administrative service typical of: (1) gasoline engines in passenger cars and light to medium duty trucks, and (2) lightly supercharged diesel engines operated in moderate duty, when ambient temperatures are above minus 20°F.

(b) Four grades of this oil are provided. Two grades are straight single viscosity grades and two are multi-viscosity grades:

Viscosity Grade
Grade 10W
Grade 30
Grade 10W-30
Grade 20W-40

3. *Lubricating Oil, Shipboard Internal Combustion Engine, High Output Diesel, MIL-L-9000.*

(a) *General.* This specification covers one grade of lubricating oil. Military Symbol 9250, suitable for use in advanced design high-output shipboard main propulsion and auxiliary diesel engines using fuel conforming to MIL-F-16884.

4. *Lubricating Oil, Aircraft Piston Engine (Ashless Dispersant), MIL-L-22851.*

(a) *General.* The lubricating oil covered by this specification is intended for use in aircraft/piston engines. Type I is an additive concentrate. Type II is a 10% blend of Type I and 90% of Grade 1100 oil conforming to MIL-L-6082 lubricating oil. Type III is a 10% blend of Type I and 90% of Grade 1065 conforming to MIL-L-6082.

5. *Oil, Lubricating, Jet Engine, MIL-L-6081.*

(a) *General.* This oil is used as a lubricant for jet engines.

(b) Two grades of this oil are provided:

1010
1005

6. *Lubricating Oil, Aircraft Turbine Engine, Synthetic Base, MIL-L-7808.*

(a) *General.* This oil is intended for use in specific models of aircraft turbine engines and helicopter transmissions.

(b) *This specification covers one grade.*

c. *Physical Properties and Characteristics.* The most important properties for these oils from the standpoint of operation are pour point, viscosity, viscosity index, sulfur content and lead corrosion.

1. *Pour point.* This is the lowest temperature at which the oil will flow under definite prescribed conditions. It is this property that is the deciding factor to enable one to determine if the oil should be used in cold weather.

2. *Viscosity.* This is a measure of the oil to resist flow. The higher the viscosity, the higher is the oil's resistance to flow.

3. *Viscosity Index.* This is a number obtained by taking viscosities of the oil at different temperatures and substituting in a formula. This index indicates the extent that the oil will thin out as the temperature increases. The higher the viscosity index, the less the oil's viscosity is affected by temperature changes.

4. *Sulfur Content.* Engine lubricating oils must be non-corrosive hence, the free and corrosive sulfur content must be low.

5. *Lead Corrosion.* Synthetic lubricating oils chemically degenerate when exposed to minute amounts of moisture and become corrosive. To avoid servicing aircraft jet engines with corrosive oils, surveillance programs are prescribed to periodically identify suitable oils.

MIL-HDBK-201B
23 September 1971

SECTION IV. GREASES

2.12 GREASES.

a. *General.* Greases are manufactured by compounding petroleum and synthetic oils with metallic soaps. The purpose of the soap is to produce a gel with the oil resulting in a grease. Greases are produced for specific purposes and care should be exercised in selecting greases to assure performance intended. Greases are used in places where lubricating oil will not remain because of its "running off" tendency. Greases being plastic solids do not have this tendency. One automotive and one aircraft grease is discussed below as examples:

b. *Types and Grades.*

1. *Grease, Automotive and Artillery, MIL-G-10924.*

(a) *General.* This specification covers one grade of grease suitable for use in the lubrication of automotive and artillery equipment under all conditions of service where temperatures range from minus 65°F to plus 175°F for MIL-G-10924B and from minus 65°F to plus 225°F for the new MIL-G-10924C grease.

2. *Grease, Aircraft, General Purpose, Wide Temperature Range, MIL-G-81322.*

(a) *General.* This specification covers one grade of grease intended for use in anti-friction bearings, wheel bearings in internal brake wheel assemblies, gear-boxes and plain bearings where both low temperatures (-65°F) and high temperatures (350°F) are required.

c. *Physical Properties and Characteristics.* The important physical properties and characteristics of greases are penetration, dropping point, and sulfur content.

1. *Penetration.* This is a measure of the consistency of grease. The higher the penetration number, the softer is the grease. The penetration is useful in classifying greases according to consistencies required in various types of service.

2. *Dropping Point.* This is the temperature at which grease passes from a plastic solid to a liquid state. Grease cannot be expected to lubricate satisfactorily at temperatures above its dropping point.

3. *Sulfur Content.* Grease must not contain sulfur or sulfur related compounds which will corrode or injure bearings.

SECTION V. RELATED COMPOUNDS

2.13 RELATED COMPOUNDS.

a. *General.* There are petroleum products other than fuels, lubricants and greases which are stored and issued in the field. Typical examples are: corrosion preventative compounds, sol-

vents and hydraulic fluids. Because of the wide variety of these products, discussion of their properties and characteristics is omitted in this publication and should be obtained from the respective product specifications.

CHAPTER 3. QUALITY SURVEILLANCE OF PETROLEUM AND RELATED PRODUCTS

SECTION I. INTRODUCTION

3.1 GENERAL.

This chapter covers, in general, the quality surveillance procedures utilized in the handling of petroleum products under military cognizance. MIL-HDBK-200, Quality Surveillance Handbook for Fuels,

Lubricants and Related Products, sets forth general instructions and minimum procedures to be used by the Military Services in the quality surveillance of petroleum and related products. It is applicable to all military activities on a world wide bases.

MIL-HDBK-201B
23 September 1971

SECTION II. QUALITY SURVEILLANCE

3.2 GENERAL.

Quality surveillance is the aggregate of measures applied to determine and maintain the physical and chemical quality of bulk and packaged fuels and lubricants in order that these products may be in a condition suitable for immediate use. Quality surveillance is successful only when an intelligent and constant program of operation, sampling, and testing is carried out. It is the responsibility of those activities storing, issuing and consuming the fuels to exercise due caution to maintain the material suitable for use as prescribed in MIL-HDBK-200.

3.3 TEST AND METHODS.

This section does not cover laboratory test methods nor any description of testing apparatus. The tests that will be performed as a minimum are those specified for the particular product in MIL-HDBK-200 and the test methods to be used will be as prescribed by the applicable product specification.

Products delivered to military activities have been completely tested at the point of origin, normally under the supervision of a military inspector. How-

ever, the surveillance of products after receipt by the government is necessary in order to check against contamination or deterioration during handling and storage.

3.4 ROUTINE TESTS ON BULK PETROLEUM PRODUCTS.

Bulk petroleum products should be sampled and tested (1) upon receipt (2) periodically while in storage and (3) upon issue (if deemed necessary). The frequency of testing each product is specified in MIL-HDBK-200. The laboratory to perform the testing will be as designated by the cognizant Military Service.

3.5 PACKAGED PETROLEUM PRODUCTS.

No receiving tests are necessary on packaged products provided the containers are externally satisfactory and the markings adequately identify the products. The frequency of testing each product is specified in MIL-HDBK-200. The laboratory to perform the testing will be designated by the cognizant Military Service.

SECTION III. UTILIZATION OF OFF-SPECIFICATION PRODUCT

3.6 GENERAL.

On numerous occasions, an off-specification product, unsuitable for its intended use, may be reclaimed for another use by downgrading, filtering, de-

hydrating, etc. MIL-HDBK-200 cites in detail the procedures, approval, etc. necessary to reclaim or otherwise use or dispose of off-specification petroleum and related products. These procedures must be followed by all military activities.

SECTION IV. EFFECT OF METALS AND METAL COMPOUNDS ON PETROLEUM PRODUCTS

3.7 GENERAL.

Certain metals and metal compounds in contact with petroleum products adversely affect the quality of these products.

- a. *Zinc and Cadmium.* Zinc and cadmium react vigorously with acidic components of petroleum fuels and sea water ballast to produce considerable soluble and insoluble contamination of the fuel. All zinc and cadmium com-

pounds and coatings including galvanized materials should be avoided in the construction and maintenance of petroleum storage, distribution and dispensing systems.

- b. *Copper and Copper Bearing Metals.* The presence of small amounts of copper and copper bearing metals in the fuel have a catalytic effect with resulting undesirable end products. Any use of these metals in static storage of one week

MIL-HDBK-201B
23 September 1971

or longer may adversely affect the stored product. Although use of these metals for transfer of fuels can be tolerated under transit conditions, their use in a transfer line to storage tanks should be avoided.

c. *Aluminum.* Aluminum in contact with petroleum fuels in the presence of salt and surface water is undesirable. Use of aluminum in contact with dry fuels in a petroleum storage, distribution and dispensing system, i.e., downstream from a filter separator is acceptable.

CHAPTER 4. TANK FARM OPERATIONS

SECTION I. INTRODUCTION

4.1 GENERAL.

Tank farm operations and operating procedures are usually the responsibility of the supervisor. These operations include gaging, sampling, filling and emptying tanks, circulation and transfer of the stored bulk product, and drawing off water. In order to perform these operations effectively, it is necessary for the supervisor to understand the planned operation. The need for proper care of the various tank accessories, including vent valves, gage hatches, tank-outlet valves, access openings, heaters, pumps, filter separators, and manifolds must also be understood.

The normal petroleum operations at a military activity consist of the receipt, storage, and issue of clean liquid petroleum products. The volume and the type of products are governed by the mission of the installation and the existing facilities. Among the specialized operations included in receipt, storage, and issue of product are: unloading and loading of tankers, barges, tank cars, and tank trucks; pipeline transfers, pumping from and into tanks, gaging, sampling; maintaining records of inventories, operation of hydrant fuel dispensing systems; operating bulk lube systems as well as a drum reconditioning, filling and packaged product storage.

SECTION II. STORAGE TANKS

4.2 GENERAL.

The purpose of the following is to define and illustrate the various types of tanks used by the Military Services for the storage of petroleum products.

4.3 TYPES.

a. *Steel Tanks.* Steel tanks are commonly used for storage of nearly every kind of petroleum product. Steel tanks in the smaller sizes of 500-barrel capacity or less may be horizontal or vertical but sizes greater than 500-barrel capacity are in most cases vertical. They may be installed either above or below ground and may be coated or uncoated.

1. *Welded Tanks.* At permanent installations petroleum products are normally stored in welded steel storage tanks which may be horizontal or vertical, installed either above or below ground. Tanks properly constructed, tested and maintained will remain

free of vapor or liquid leaks for a long period of time.

2. *Bolted Tanks.* Bolted tanks in military service range in size from about 100 to 10,000 barrels in capacity. The seams are sealed with synthetic rubber gaskets supplemented by a special sealing compound. For sealing the space around the bolts, a bolt-sealing compound may be applied. Bolted tanks may be used for any temporary or emergency fuel oil service. Although they are considered only as a necessary expedient when something better is not available, bolted tanks, because of fund limitations, are being used in many military installations as semi-permanent storage for all types of fuels. These tanks may be procured through normal military channels with approved interior coatings.

3. *Horizontal Tanks.* Horizontal tanks are cylindrical in shape, are placed on supports

MIL-HDBK-201B
23 September 1971

if above ground, or they may be installed underground. They are relatively small and are normally used for local storage and issue of fuels to vehicles, aircraft, and for storage and issue of lubricating oils.

4. *Cone Roof Tanks.* The cone roof tank is the most commonly used, primarily because of its relatively low cost of construction as compared with other designs. This type of tank is subject to breathing and filling losses, and if the roof is not properly maintained in gastight condition, windage losses may also result. The roof is coned toward the center of the tank with sufficient pitch to provide adequate drainage, usually 3/4-inch pitch to the foot. Cone roof tanks may be used for storage of practically all grades of liquid petroleum products. Internal pan floaters in cone roof tanks have been adopted by the military services. This type of tank offers the conservation and safe handling advantages of the standard floating roof tank, but without the disadvantages associated with the introduction of rain, snow and sleet in the open

roof tank. Figure 1 is a cutaway drawing of the internal pan floater tank.

5. *Floating Roof Tanks.* The standard floating roof tanks are designed to permit the roof to float on the surface of the liquid rising or falling with changes in product levels. There is no vapor space and consequently, with proper design of the deck and an effective closure (vapor seal) around the edge of the floating roof, breathing and filling losses are practically eliminated. Fire hazard is minimized because little vapor, if any, is present above the product level in the tank. The closure around the edge of the floating roof consists of a continuous gastight, weather-proof, synthetic rubber coated asbestos fabric attached to a sealing ring that slides along the face of the tank shell as the roof moves up and down. This sealing ring is maintained in close contact with the inside of the tank shell by means of counter-weighted hangers or similar devices which exert constant pressure outward against the

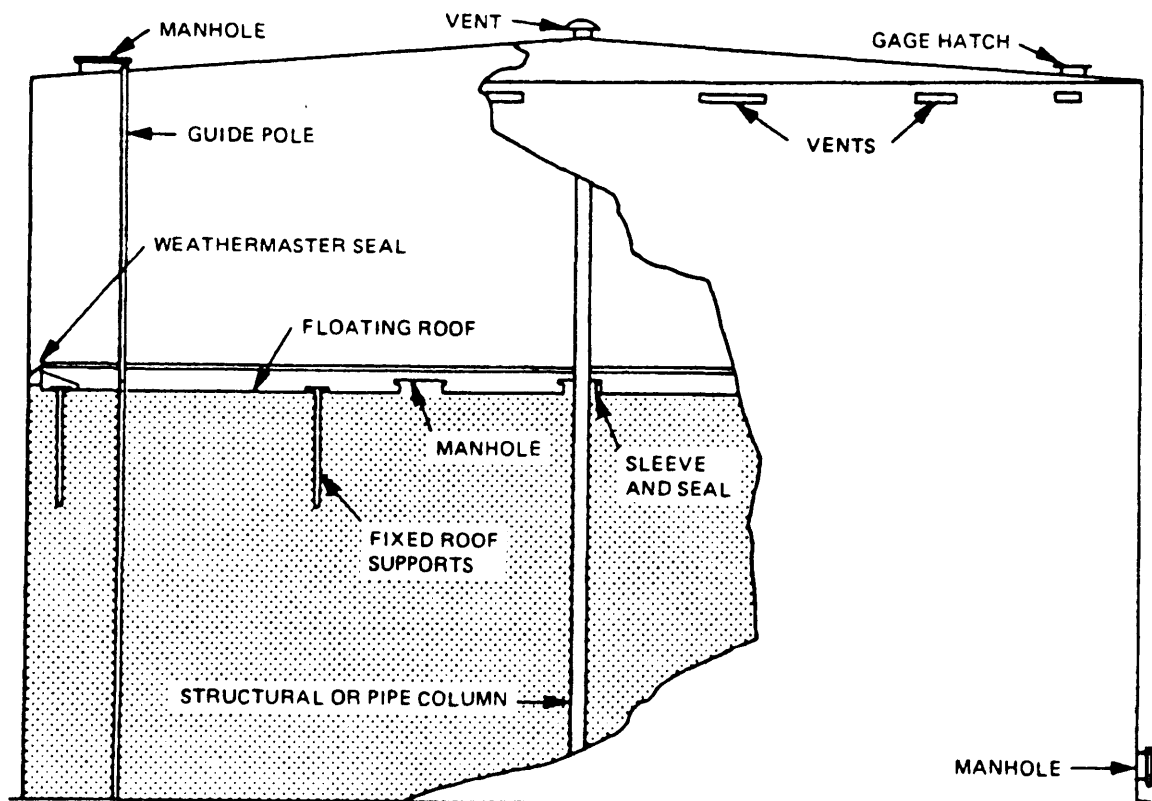

Figure 1.--Tank, steel, liquid storage, fixed cone roof, with internal floating pan.

MIL-HDBK-201B
23 September 1971

tank shell. There are two general types of floating roof tanks in use: the pan type with cone roof cover, the pontoon type and the double deck type. Floating roof tanks are best adapted for use in volatile product service where inventory turnover is rapid. Open top floating roof tanks are not well adapted for use in extremely cold climate because of the operating difficulties caused by accumulation of snow and ice.

b. *Concrete Tanks.* The majority of underground concrete tanks at military installations are vertical circular cylinders having walls of prestressed concrete. Steel tension members are placed around the shell of the tank in a series of rings or a continuous spiral. The tension members are stressed to a prescribed percentage of the yield point of the metal. Thus the concrete is placed in compression and remain in compression for all values of liquid head which the tank will contain. The exterior of the tank shell is then protected with a second pour of concrete, or the entire external surface of the shell is "gunited". Where concrete tanks are to be used for the storage of fuels heavier than diesel fuel, the interior surfaces are coated with a sodium silicate solution so as to fill the interstices of the concrete for the initial filling. Where concrete tanks are to be used for the storage of diesel and lighter types of fuel, the interior surfaces are normally provided with a coating system. Temperature of the contents, or more important, the rate of change of the contents of concrete tanks must be limited to prevent excessive differences in temperature between the inside concrete wall surfaces and the outside steel rod bands. It will be unsafe to have the concrete at any time more than 75°F warmer than the steel rod bands. This is the uppermost limit and is much more than is desirable. Therefore, the flow of oil into a cold empty concrete tank should be started slowly when the oil temperature is more than 65°F warmer than the tank temperature. If an underground tank is heated slowly the steel and concrete temperature will not differ greatly because of the insulating effect of the earthen fill surrounding the tank. The rate of heating of oil in storage should be limited to 4°F per hour and the oil temperature should not be raised above the top limit of 155°F. This limit is more than suffi-

cient for all normal depot operations except reclamation processes for which steel tanks should be used rather than concrete. Oil temperature in above ground concrete tanks should not exceed their temperature by more than 85°F. Pits containing pumps and heaters may be located alongside of an underground tank. Ladders, or other means of access, are provided for the operator; safety rules require offsets to prevent a long fall. If often used, ladders should be replaced by stairs where this is feasible. Deep access pits are not considered safe due to gas; adequate forced ventilation is necessary for all such pits especially when adjacent to gasoline and jet fuel tanks. A change from Navy special or diesel fuel to gasoline or jet fuel is not recommended, but in case of emergency if a Navy special or diesel fuel tank has to be changed to gasoline or jet fuel service, a vertical well type tank should be blanked off and the outside pit abandoned; unless the pit is abandoned and filled in, it may become a hazardous space due to an accumulation of explosive vapors.

c. *Collapsible Tanks.* Collapsible rubber tanks can be rapidly installed for emergency storage applications. Such tanks are often employed in lieu of bolted tanks and range in size from 10,000 to 200,000 gallons in capacity. If permanence of storage is expected to exceed one year these tanks should be replaced with steel tanks. Field conditions may dictate the use of the 500 gallon collapsible drum for temporary storage.

d. *Miscellaneous Tanks.* Various other types of tanks will be found at fuel storage installations including water tanks, buried service station tanks, drum filling storage tanks, drum filling plant surge tanks, cooker tanks at oil reclamation plants, burner fuel supply tanks, etc. The type of tank used for these purposes depends upon the operation to be performed and the tanks available for use.

1. *Auxiliary Tanks.* Small auxiliary tanks are frequently used for issues of small quantities of products such as at loading racks, small craft piers, etc. More accurate gaging of small deliveries is possible when such tanks are used. Similar but larger tanks to suit particular needs are also frequently used for

MIL-HDBK-201B
 23 September 1971

defueling ships, thus providing segregated storage for the product until tests can be run to determine its further use or disposal. The use of auxiliary tanks increases the flexibility of any tank farm.

2. **Ballast Tanks.** Many types of tanks are provided for receiving ballast. They may be open or roofed, steel or concrete tanks, or even an open banked earth pond type container. They are provided not only to receive ballast from ships, but are also used for storing ballast to be pumped back to ships when necessary. They are frequently used in conjunction with oil reclamation plants.
3. **Surge Tanks.** Surge tanks or shore receiving tanks are used whenever the rate of flow is not constant or where pumping must be done over long distances. For example, a tanker discharging to a tank farm several miles distant would pump into such a surge tank located near the pier. Shore booster pumps would then take suction on this tank and pump the product to the tank farm. The use of a surge tank insures the booster pump

of a constant supply of oil and allows for surges in the rate of tanker discharge.

4.4 TANK ACCESSORIES.

- a. **Vents.** Open vents may be used to provide venting for tanks in which fuel oils with a flash point of 100°F and above are stored. There is no reason to have anything more complex than an open vent pipe (protected with a hood and a coarse screen to keep out rain, birds, and insects) on any under ground tanks assigned to boiler or burner fuel, or diesel fuel, for these products do not give off flammable vapors and are not appreciably affected by contact with the air. (Any fuel oil, however, will change in character and evaporate if exposed for a long period of time to the wind and sunlight in an open tank without a roof.) Open vents are also suitable for above ground tanks assigned to non-volatile fuel storage tanks, although under certain conditions breather valves may be justified in the latter service. (See figure 2.)
- b. **Breather Valves.** Breather valves are installed on above ground gasoline or jet fuel storage

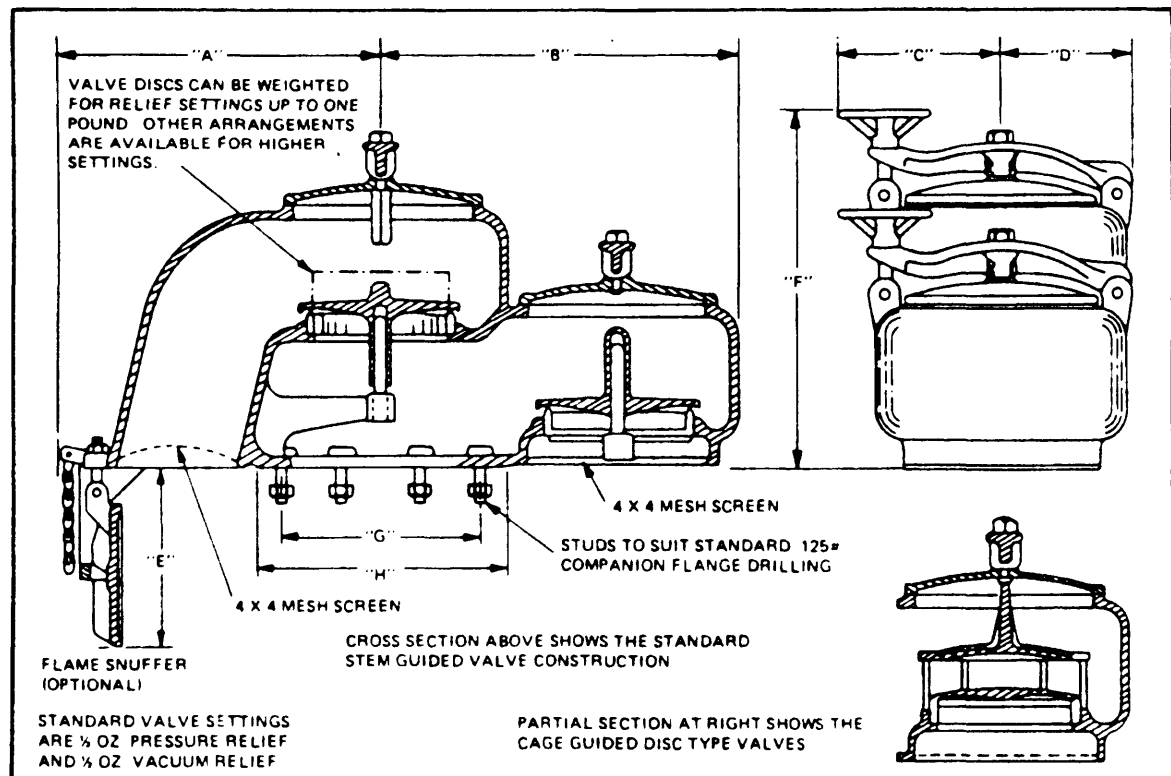

Figure 2.- Pressure-vacuum tank vents.

MIL-HDBK-201B
23 September 1971

tanks. They will also be found on large underground tanks, but are commonly omitted if the underground tank is of less than 2,500 gallons in capacity. The free vents of small tanks shall be carried to a safe elevation above the ground. Breather valves on underground tanks are normally closed. They thus retard the entrance of moisture into the tanks when the tanks are idle. Breather valves should not be used in burner fuel oil tanks. Emergency vents are provided to take care of the extra flow of vapor from an above ground tank if it should be exposed to fire. These vents may take the form of additional or larger vents or breather valves. (See API Bulletin RF 2000, Guide for Tank Venting.)

- c. *Flame Arrestors.* Flame arrestors are installed on some storage tanks. Flame arrestors must be carefully maintained during freezing weather and steps taken to prevent screens from clogging due to frost. In some localities, it is preferable to remove the flame arrestor screens (or equivalent) during extreme continued cold weather.
- d. *Tank Outlets.* Some tanks have been equipped with swing-line outlets, that is, with an outlet pipe that may be raised and lowered by means of a floating device attached to the free end of the line or by a manually operated winch. These swing lines are valuable in permitting clean product to be drawn off in case the product in a tank has stratified or contains wet oil emulsion, or sludge in the lower levels. They are a necessity in tanks used for settling and dehydrating wet or contaminated stock. Sometimes in confined areas, rules require the free end of swing lines to be raised above the oil level when not actually in use. In normal operation, if the free end of the swing line is constantly kept at a high elevation drawing only from the top layer of the product, the heavier parts of the product will settle and accumulate on the tank bottom. If the free end of the swing line is constantly kept too low, unacceptable quality product may be drawn off for issue. The best operation is the one that results in a minimum accumulation of bottom settlings. The outflow opening on tanks not equipped with swing lines will usually be about 10 to 18 inches above the tank bottom; the line may come out through the tank bottom, but on tanks of later construction the opening will be through the shell. It is

evident that the product as held in storage must be on specification at the level of the outlet from which it is drawn. Product levels in certain tanks used for issue may be maintained by transferring product to them from the other tanks during issue. Where the outlet pipe "looks up" and is not surmounted by a suitable plate baffle or deflector, and product is withdrawn at a high flow rate, a vortex may form and cause air to be drawn into the outlet. In such cases, the tank has to be pumped out at a lower flow rate when the liquid level is below the 4 or 5 foot level. Military tanks have been improved in design so that the bottoms take the shape of an inverted cone. With the bottoms sloped to the center drain, removal of water is greatly improved and tanks of this design may be easily drained of all contents prior to inspection and cleaning.

- e. *Gage and Thief Hatches.* On above ground storage, gage hatches should be so located that the gager can gage the tank while standing on the platform at the top of the tank ladder or stairway. This will avoid the possibility of the man's weight affecting the height of the reference mark. Where this is impossible, the same man shall stand on the roof for both the opening and closing gages. The hatches should be located so that gaging tapes will not be fouled by obstructions inside the tank. Hatches should be closed immediately after use. Gage and thief hatches are normally the same opening. On some gasoline storage tanks, where vapor pressure is maintained and it is necessary to use a "sampling bob", the hatch must have two pressure seals to permit the insertion and removal of the "bob". Manufacturer's instructions should be followed.
 - 1. *Mannholes.* Normally tanks have one or more manholes in the roof or side of above ground tanks. The manholes are used mainly for access and ventilation prior to and during cleaning or repairing tanks. Manhole covers will be kept tightly closed to prevent vapors from escaping and loss of product.
- f. *Oil Heaters.* Information about the various kinds of heaters that may be used can be obtained from the appropriate technical services. The simplest is the grid-type heater, made of manifolded straight lengths of pipe or in a flat

MIL-HDBK-201B
23 September 1971

serpentine arrangement just above the tank bottom; this type is suitable only for raising the temperature of all the oil in the tank as a whole. The most commonly used heater, the shell and tube type is usually installed outside the tank. A portable type has been designed to be lowered through a roof manhole. Direct fired heaters are occasionally installed; these require special care in their use. They must be operated according to manufacturer's instructions.

- g. *Pump and Pump Manifolds (tank pits)* Many underground tanks are equipped with individual pumps of the rotary type, motor or turbine driven, located in pits or chambers close to the tank. These pumps are provided with necessary accessories such as a bypass, relief valve and check valve. These will be usually connected so that the tank's contents can be circulated. Many underground tanks in diesel fuel or gasoline service are equipped with either submerged pumping units or vertical well-type pumps. In the latter pump, the driving motor is mounted in a shallow roofed-over space above the tank roof. The suction line of such a pump normally extends from the tank roof to within 8 to 10 inches of the tank bottom, the end of the

suction line with pumping units attached is usually placed above a horizontal baffle plate or pad to prevent the pump drawing in bottom water. This type of pump can also transfer burner fuel oil when the viscosity is not too high. A similar but smaller well-type centrifugal pump is also installed for pumping out bottom water. Where there are no individual tank pumps, one or more centrifugal pumps as a group will serve a number of tanks. The operation of such groups will be similar in principle to their operation in a booster pumphouse. Where such pumps are not under positive suction when the product in the tanks is at a low level, they will require priming but, after flow is started, they will continue to operate at a low suction lift.

- h. *Gage Tables* Gage tables based on actual volumetric measurement must be available for each tank. The tables show the capacity of each inch of tank height, usually with an interpolation table for each one-eighth inch. Volumetric capacities or gage tables for ship's tanks as a rule are calculated from drawings. For this reason, ship's ullage gages should be considered only approximately correct.

SECTION III. PIPELINES (INTRA-TERMINALS)

4.5 GENERAL.

This section outlines the basic principles for safe and efficient operations of pipeline systems. Special operations peculiar to pipelines are treated under receiving, issuing and storage.

4.6 TYPES.

The pipeline systems are divided into three (3) basic types, single line, loop system, and double line. Combinations of the 3 will be found. An individual line system consists of 1 line for each product from tankage to dock and loading and receiving racks. In a loop system, tanks and possibly pier risers are connected to a complete loop so that in case one side is damaged, an alternate path for product transfer is available. Double line systems are systems in which a tank is serviced by two main lines. This system has most, if not all, the advantages of a loop system and

in addition permits tanks to be circulated either individually or by transfer.

4.7 PIPELINE ACCESSORIES.

- a. *Pipe* Fuel pipelines usually range in size from 4 to 30 inches in diameter. Size is based on expected throughput and an economic analysis of operating and maintenance costs versus first cost of installation. Details of construction are based on recognized engineering codes such as ANSI, ASTM and API publications.
- b. *Valves* The more common types of pipeline valves are gate valves, plug valves, ball valves and check valves. Other types such as diaphragm, float, globe, lever balance, needle, pressure-reducing, pressure-regulators, and safety valves are used in smaller lines or for more specialized purposes.

MIL-HDBK-201B
23 September 1971

1. Gate valves are available in rising stem types which give a visible indication of gate position and nonrising stem where space does not permit the other type. Although pressure drop through open gate valves offers minimum resistance to flow, they are sometimes difficult to open when large pressure differentials are present.
 2. Plug valves are classified as lubricated or nonlubricated types. The lubricated type plug valves are found on older systems but are considered obsolete since the lubricant necessary to operate them can contribute significantly to fuel contamination. Plug valve openings are usually smaller than line size. However, full size openings are used on main pipelines in order to pass a line scraper or cleaner.
 3. Ball valves are also used and installed in piping systems similar to systems utilizing plug valves. The ball is generally of steel and is provided with a teflon or similar type material as a seat media. Valve passages generally permit full pipe size passage of product and cleaning equipment.
 4. Check valves are used to restrict flow of one direction only. They are gravity and pressure operated. Some types are equipped for manual operation for emergency purposes and during special operations.
- c. *Expansion Joints.* Expansion joints of the mechanical type are not generally used. When installed, adequate anchorage is essential. Expansion of piping is usually controlled by changing direction of the piping.
- d. *Blocks and Blinds.* When two different products are in adjacent connected lines, a single valve of the usual type (gate or plug) is not sufficient to separate them except where the plug operates as a double block and bleed valve. If crossover connections between different product lines are authorized, two valves with an open (locked or sealed open) drain between, positive blinds or double block and bleed valves with an open drain, are required.
- e. *Pressure Relief Systems.* Small by-pass relief valves are installed for the purpose of relieving line pressure due to the thermal expansion of

the contents of the line, where sections may be closed off.

f. *Sediment Strainers and Sand Traps.*

1. *Basket type strainers.* Basket type wire mesh strainers are generally installed on the suction side of pumps as sediment strainers. Their purpose is two-fold, (1) to remove gross sediment before the fuel is pumped into a storage tank and thereby decreasing the frequency for tank cleanings and (2) by removing solids from the fuels, pumps are protected from undue wear due to abrasive sediment.
 2. *Sand Traps.* Sand traps function in a manner similar to sediment strainers by collecting dirt, scale and floating debris pumped through a pipeline or that accumulated during pipeline cleanings. Normally, sand traps are installed in pairs on the suction side of main line pumping stations.
- g. *Line Identification.* Identification of petroleum lines must be in accordance with the Military Standard MIL-STD-161, Identification Methods for Bulk Petroleum Products Systems. Under no circumstances will colors other than yellow for warning and black and white for identification be assigned to petroleum products. Lines for other than petroleum products will be marked in accordance with MIL-STD-101.

4.8 PIPELINE TRANSFERS.

- a. *Precleaning.* After construction, all lines should be cleaned by circulation at as rapid a rate as possible to remove sand, soil, trash and water. If the lines are so arranged that they cannot be circulated, product should be pumped back and forth. A harbor barge or tanker or tank vehicle may be used for this purpose. Strainers must be frequently inspected and cleaned as required during this operation. Where facilities are available and design permits, deformable pigs, spheres or scrapers should be run through lines.
- b. *Maintaining Product Quality.* It is important to maintain product purity in all fuels handling and storage situations to minimize the possibility of delivering contaminated fuels to aircraft, vehicles, and other fuel consuming equipment.

MIL-HDBK-201B
 23 September 1971

1. *Centrifugal Separators.* Centrifugal type separators are effective and are used wherever practical in separating water and gross solids during transfers between bulk storage areas or during off-loading of barges.
 2. *Filter Separators.* All aviation fuels must be passed through a filter separator between the pumps and the tank car/truck loading racks and wherever fuel is being dispensed directly into aircraft. Filter separators must qualify under specification MIL-F-8901 (latest revision) and the capacity of the unit must be equal to the capacity of the pump moving the fuel as a minimum.
- c. *Flow Characteristics.* The pressure loss in pipelines is usually dependent on the specific gravity, rate of flow and the viscosity or the resistivity to flow of the liquid. Pressure loss varies greatly with different liquids, and when considering more viscous fuels, it decreases due to rising temperatures. In extreme cold the increased density and possible increased viscosity of fuels should be considered in evaluating operating conditions.
- d. *Optimum Pumping Temperatures.* It is often necessary to preheat burner fuel oils in order to assure maximum pumping rates. However, there is an optimum pumping temperature for fuel oils, and nothing worthwhile in pumping rate is gained by heating the product beyond this point. For example

Grade of fuel	Probable best range of transfer temperature
Navy Special 25 S.S.F. = 122°F	50 to 75°F

- e. *Heating of Pipelines.* Heating of oil for pumping is initially accomplished in shore storage tanks or ship's tanks. However, unless the oil lines are insulated or placed in a heated tunnel, there will be several degrees drop in temperature through the pipeline. Some installations will have steam line tracers or gut lines. Condensate from these lines must be closely monitored to insure against freezing and rendering both steam and oil lines inoperative.
- f. *Displacing or Filling Lines.* Lines are sometimes drained and then refilled. Where feasible,

lines should always be filled or refilled. When lines are filled with product, all block valves are closed. Due to line temperature changes, pressure loss or air release, lines must be filled or "packed" before each operation to insure accurate issues or receipts. Filling the line may be accomplished by circulating product in the lines with or without booster pumps where a loop or double line system is available. Filling by allowing the air to escape through one or more vents at the high points and at the end of the line is much slower and, in some cases, is the only means available. When lines are filled in this manner, air pockets will probably remain which may cause error in gaging totals. Water may be used to displace lines but its use is extremely undesirable on account of the difficulty of removing it completely. Use of water will be avoided unless specifically authorized by competent technical authority.

- g. *Multiproduct Lines.* Most depots have been constructed with at least one line for each grade of fuel and should be operated on that basis; however, in some cases where the number of products exceeds the number of lines available, it will be necessary to move more than one product through a single line.

1. *Conversion Between Grades of Residual Fuel.* If two grades of residual fuel should have to be pumped through the same line, one transfer may follow another with the switch made so as to protect the quality of the lighter grade at the point of delivery by throwing the zone of mixture into the heavier grade.
2. *Conversion Between Diesel Fuel and Other Burner Fuel Oils.* Drain the line of diesel and circulate the warm burner fuel rapidly. Normally 1 to 2 percent contamination of diesel is compatible with most burner fuels.
3. *Conversion Between Grades of Gasoline in Same Line.* When bulk gasoline is transferred, the ideal and usual rule is one line for each grade. In cases where more than one grade of gasoline must be transferred in a single line, the interfacial mixture will be pumped into the lower grade of gasoline. Gravity may or may not afford a closer check depending on the gravity difference of the two grades. No manifold connections

MIL-HDBK-201B
23 September 1971

should be permitted between aviation gasoline and other grades of gasoline unless double block valves between have been provided. Where changes from one grade of gasoline to another grade are a normal condition, spectacle blinds or a double block and bleed valve should be used.

4. *Conversion Between Jet Fuel and Other Products.* Conversion of jet fuel lines to other products normally requires complete displacement and flushing of the line under the supervision of a petroleum inspector, if one is available, or guidance may be requested from the responsible technical service.

5. *Conversion from Gasoline to Jet Fuel.* Conversion of aviation gasoline lines to jet fuel requires careful draining of lines or displacement of the gasoline with jet fuel. A small amount of jet fuel will contaminate gasoline, but a small amount of gasoline may not adversely affect JP-4 but will affect JP-5. Water should not be used to displace gasoline or jet fuel.

h. *Surge Pressure.* Any liquid moving in a closed channel, in this case a pipeline, has momentum. If the flow is too suddenly stopped, its own momentum will cause it to be elastically compressed against the end closure in the line, greatly increasing the terminal pressure at the valve being closed. This extra pressure, or surge pressure is added to the pressure already in the line. Line test pressures can be exceeded and lines ruptured by this kind of hydraulic shock.

4.9 GENERAL PIPELINE OPERATING RULES.

If the following rules are carefully observed, pipeline operations will be carried out efficiently and safely without loss of product or damage to equipment:

a. Issue complete written orders as appropriate for each operation assigning personnel to definite duties and listing lines, valves, pumps, tanks to be used, products and quantities to be received or issued, location of vessel, estimated time of vessel arrival and beginning operation, number and size of hoses and hose-handling equipment to be used, communications including telephone control systems, fire-fighting equipment

to have on hand and any special instructions or precautions that might be required.

b. Assign only experienced and qualified personnel to independent work, making sure that each man receives and understands complete instructions covering the operation.

c. Start and stop operations slowly and carefully. Take plenty of time to open and close valves. Bring pressures up gradually. Observe pressure gages.

d. Train all personnel to know entire system so each will be familiar with what the others are doing.

e. Never exceed working pressure limits.

f. Never cut off one tank before cutting another into the same line system.

g. Always have positive communications between operating points, whether they are from pier to tank farm, pier to pumphouse, tank to tank, etc. Never assume what the other fellow might be going. Know for sure.

h. Unless necessary, do not have more than one tank open to a line system except for tank switches.

i. Always have proper tools for the job and the right key for locked valve and access pits.

j. Observe all safety precautions. Stop an operation when conditions become unsafe. Investigate fumes, pressure loss, etc., before continuing an operation.

k. Always plan ahead. Train each man to anticipate emergencies so that his actions and reactions will be what are required to cope with situations that may arise.

l. Never use a bar or other means to force a gate valve closed. When a nonrising stem valve is opened the wheel should be turned at least one-half turn away from the full open limit to allow free movement as an indication that valve is open.

m. Always verify accuracy of operation lineup. Never assume a valve is open or closed. Verify flow in or out of tank as soon as possible after start of an operation. Read automatic tank gage within 15 minutes after start of operation, and

periodically thereafter. Manual gaging of JP-4 tanks will not be accomplished while tank is being emptied or filled. In the case of manual gaging of other fuels, extreme precautionary measures as directed by each military department will be followed.

4.10 SERVICING VALVES AND FITTINGS.

Servicing valves and pipe fittings is considered operational work to be performed by operating per-

sonnel. Servicing includes lubricating, cleaning, line and equipment painting and identifying, adjusting, minor repacking and inspecting. These duties may be carried out by less skilled personnel. Dismantling, removing, major repacking, replacement, of glands and stuffing boxes, resetting and adjustments of governors and safety limits, etc., are considered operational maintenance to be performed by especially assigned system maintenance personnel.

SECTION IV. PUMPING OPERATIONS

4.11 GENERAL.

This section deals with the various types of pumps encountered at military fuel installations.

4.12 CENTRIFUGAL PUMPS.

Due to their simplicity and adaptability to a wide variety of operating conditions, centrifugal pumps are widely used. They can be modified to operate over a wide range of heads, will handle liquids at all normal temperatures and operate at speeds that are standard for motors or turbines. The characteristics of these pumps are such that flow from them is continuous, and their discharge can be throttled without building up excessive pressures in the pumps or overloading the driving unit.

While the centrifugal pumps are not as flexible or versatile as reciprocating pumps, they are usually the most economical and satisfactory type to install when operating conditions do not vary appreciably. They may be connected to any type of drive.

Centrifugal pumps are not usually self-priming, and where liquid does not flow to the pump, provision must be made for priming. Self-priming pumps can be obtained in the smaller sizes, and automatic priming equipment is available for any size pump. The operation of centrifugal pumps is very sensitive to suction conditions; abnormally high suction lifts (either actual or caused by friction in the suction line) usually result in serious reduction of capacity and efficiency in the pump, frequently leading to trouble from vibration and cavitation. (See figure 3.)

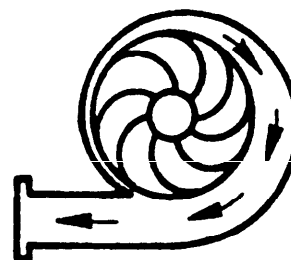

Figure 3.—Section showing impeller and volute of a centrifugal pump.

4.13 RECIPROCATING PUMPS.

For general service conditions, and especially where it is necessary to maintain a fixed capacity against a variable head, reciprocating pumps are frequently specified. This is also the case where the viscosities of the liquids vary. Within reasonably wide limits, it is possible to vary the pump capacity by adjusting the speed. Reciprocating pumps are of the positive displacement type and are self-priming. Discharge is pulsating, but may be smoothed out considerably by use of a suitable air chamber on the discharge side.

Power driven reciprocating pumps have a high efficiency and deliver at a practically constant rate against widely varying heads. Direct acting steam driven piston type pumps equipped with suitable control also have this advantage, but to a lesser degree. A reciprocating pump will develop excessive pressure if delivery is obstructed. A relief valve is necessary on the discharge of this pump.

MIL-HDBK-201B
23 September 1971

4.14 ROTARY PUMPS.

All types of rotary pumps have certain characteristics that permit them to handle high viscosity oils under conditions for which reciprocating or centrifugal pumps are not suited. The rotary type combines the constant-flow characteristics of the centrifugal pump with the positive-discharge feature of the reciprocating type. They are self-priming and, on most types, have a constant discharge flow regardless of their close pressure clearance which permits them to pull a high vacuum. Relief valves are required on discharge piping. (See Figures 4 and 5.)

4.15 PRIME MOVERS.

Generally, the pumps used for the purpose of moving petroleum products will be driven by constant speed electric motors, diesel or gasoline engine, turbine engine or steam turbine drive. For higher speed, steam actuated pistons or steam turbine drive, the rotary motion of the driver would be converted through means of a suitable gear drive, to a reduced number of revolutions per minute of a crankshaft.

Slow speed prime movers such as diesel engines (as compared to electric motors or steam turbines), may be used to drive centrifugal pumps through geared

speed increasers. Electric motor turbine and diesel engine driven pumps will predominate.

4.16 HAZARD OF SHUTTING DOWN WHEN STATIC HEAD EXCEEDS ALLOWABLE SHIP PRESSURE.

When unloading a tank ship, it is obvious that a shutdown of the booster pump, either by mistake or due to power failure, will stop the flow and cause the full delivery head from the ship's pumps to back up at the pier.

There may be a surge pressure in addition. This may conceivably burst the hose, and for that reason every precaution should be taken to avoid it.

4.17 OPERATION OF VARIABLE SPEED PUMPS.

Some installations have centrifugal or gear pumps driven by variable speed electric motors or through appropriate reduction gears by steam turbines, or direct acting steam pumps.

Variable speed (slip ring motor) electric driven pumps will be controlled down to half speed or less by the electric controller. Beyond this, by-passing is usually necessary if the pumps are of the positive displacement type.

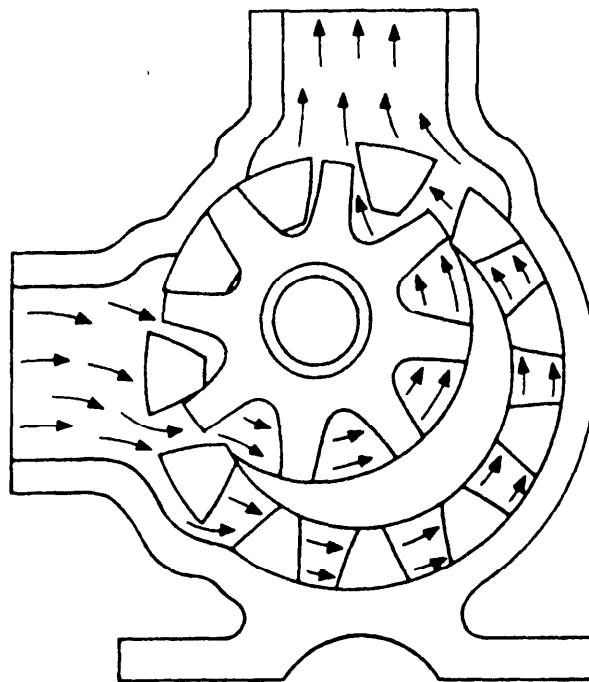

Figure 4.—Internal gear rotary pump.

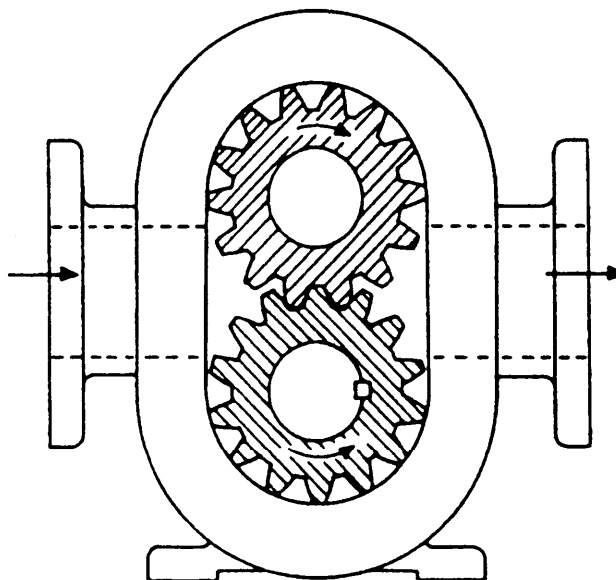

Figure 5.- External gear rotary pump.

The pumping rate of steam turbine driven pumps can be controlled by varying the supply of steam. However, the turbines will have constant speed governors and can be controlled the same as motor-driven pumps.

The pumping rate of direct acting pumps is always varied by throttling the steam. Starting and controlling direct acting variable-speed pumps delivering directly from tankage and not operated in series with other pumps offers no special problem. When the lines have been opened, the pump may be started by opening the steam valve.

4.18 PUMP SERVICING.

In order to get the best performance from operating equipment and to minimize repairs, the oper-

ators must become thoroughly familiar with operating instructions furnished by the manufacturer as well as general instructions included in military handbooks of operation and maintenance instructions.

4.19 SAFETY RULES AND PRECAUTIONS PERTAINING TO PUMPING AND PUMPHOUSE OPERATIONS.

Operators trained and familiar with the pumphouse operations should be instructed to notify maintenance forces immediately on noticing significant changes of operating characteristics of major pumping equipment. Safety precautions of applicable military manuals (see Appendix B) and operating instructions for specific installations will be followed.

SECTION V. TANK TRUCK AND TANK CAR OPERATIONS

4.20 GENERAL.

This section covers the operations of tank truck and tank car loading and unloading which will be performed at most military installations. It is intended to present here a description of the general type of facilities and to suggest a basic guide for the safe, accurate, and efficient procedures for tank car

and tank truck operations. The truck loading stand and the tank car rack or stand will usually be equipped for both loading and unloading.

4.21 TANK CAR AND TANK TRUCK EQUIPMENT.

Tank trucks and railroad tank cars are used for transporting bulk petroleum products between points

MIL-HDBK-201B
23 September 1971

not served by pipeline or water transportation facilities. Tank trucks have an advantage over tank cars in that they can deliver directly to ultimate consuming equipment. Tank trucks, depending on the type of fuel being transported, may be equipped with pumps for delivering the product. Other truck equipment, primarily on aircraft refuelers, may include emergency vent valves, filter separators, strainers, air eliminators, meters, hose, hose nozzles equipped with screens, electrical bonding wire and clips, sampling cocks, and fire extinguishers or fire extinguishing systems. Since tank cars do not deliver to ultimate consuming equipment, they are equipped only with venting devices, bottom outlet discharge, and dome openings for filling.

- a. *Preloading Inspections.* Tank cars and tank trucks as previously stated should be examined prior to loading to make sure they are suitable for transporting the products to be loaded. Equipment must be safe, road-worthy, and free of leaks; in addition, dome covers of tank cars and tank trucks should be adequately equipped for sealing. Liquids remaining from the previous haul should be sampled and identification tests performed. Liquids remaining in tank cars and tank trucks from the previous shipment, which are not the same as the product to be loaded, will be drained prior to loading. When considered necessary, tank cars or tank trucks may be flushed with a small amount of product next to be loaded to remove the last traces of clingage, as well as rust and scale from the outlet sump of tank cars and outlet lines of tank trucks. It is again emphasized that the bonding connections between truck and fill stand must be made before hose connections. These bonds shall not be removed until the hose has been disconnected. The driver of the tank truck or other personnel should not be in the cab during filling operations.
- b. *Cleaning Compartments.* Compartments should be cleaned in accordance with Departmental Directives.
- c. *Loading.* Bottom loading is the preferred method for filling of tank cars and tank trucks and whenever possible should be used. Bottom loading is an excellent safety precaution in connection with all volatile fuels to prevent vapor loss, reduce static electrical generation and protect the fuel against contamination from outside

sources. Care must be exercised to provide for product shut off notification. At installations without a bottom loading capability and when submerged type loading arms are provided, the rack man or the driver shall be instructed regarding their proper use. It must be made clear that the purpose is defeated if the drop tube is not extended to the bottom of the compartment. The drop tube must be used in a perpendicular or nearly perpendicular position in order to be effective. If necessary, the truck should be moved to accomplish this. The drop tube should never be used in a horizontal position merely for the purpose of reaching a compartment that is normally out of reach. In either type of loading, all Light Products to be filled into the tank truck or tank car should be processed through a filter separator.

- d. *Inspection After Loading.* Each carrier will be checked for complete loading; that is, shell full in the case of tank cars, or to the calibrated marker in case of tank trucks and tank trailers. Individual deliveries of products, other than Navy special or residual fuels, in excess of 3,500 gallons, and all individual deliveries of Navy special or residual fuels regardless of quantity shall be corrected to a standard temperature of 60°F in accordance with appropriate tables. Small delivery of a minor recurring nature shall be determined by meter without temperature correction. A representative sample will be taken from each loaded tank car or tank truck and examined to determine presence of rust, water, or other visible contaminant prior to release for shipment. If laboratory facilities are available at the loading point, and contamination or intermixing is suspected a sample will be sent to the laboratory for identification tests to assure product quality. Additional samples will be retained for the period designated by the assigned inspector. Where deliveries are other than within the confines of the activity where loaded, each tank car, commercial tank truck, and Government field servicing unit loaded will be sealed at the loading point in such a manner that access cannot be gained to the contents, or contents removed without breaking the seal. Approved identification seals of a type which cannot be removed after application without actually destroying the seals will be used. The marking

MIL-HDBK-201B
23 September 1971

on the seals will be indicated on all shipping documents. Seals may be applied to loaded carriers transporting other types of petroleum products at the discretion of the ordering officer.

- e. *Quantity and Quality Checking Before Unloading.* Incoming tank cars and tank trucks will have seals intact. The identification seal numbers will be recorded on the DD Form 250 or other shipping document forwarded by the supplier at the time of shipment. The shipping document will also list the specification and grade number of product and the quantity shipped. Identification of the container and serial numbers of applied seals will be checked with information on the DD Form 250. The contents of tank cars and tank trucks will be sampled prior to unloading. Samples so obtained will be visually examined for appearance, color, and tested for gravity when so directed to assure proper grade and freedom from contamination. A sample will be taken from each carrier prior to unloading into storage and

visually examined and if necessary, further checked to assure that contents are the same as listed on the accompanying shipping document. Any shortages in quantity noted on receipt of any petroleum product in tank cars or tank trucks will be made a matter of record.

- f. *Unloading Precautions.* When unloading directly into planes, vehicles, or equipment, a primary point is to ascertain before the beginning of the operation the approximate volume to be discharged. During the operation, care must be taken to prevent spillage and overflow. It is upon the occurrence of a spill or overflow that low flash petroleum products become hazardous. If this happens, prompt action to stop the flow and clean up the spill is necessary (see Chapter VII for safety precautions). Aircraft fuels discharged directly into aircraft will be processed through a filter separator. Clean products dispensed into other equipment, when possible, should be processed through a filter separator.

SECTION VI. TANKER OPERATIONS

4.22 GENERAL.

In order to prepare the shore activity for the receipt of a fuel cargo by tanker, the tanker arrival time and the kind and amount of petroleum product to be received ashore should be known in advance so that all shore arrangements for cargo receipt can be made in advance of docking time. Issuing fuel oils at a military fuel depot may include loading tankers but more often will consist of fueling naval vessels and loading harbor barges at a pier or wharf. Fueling naval vessels at sea is not described in this handbook. See chapter 7 for safety precautions applicable to these operations.

- a. *Receiving Operations.* The supervisor should prepare and post written orders to designate the following:
1. Berth to be used.
 2. Pipelines to be used
 3. Number and sizes of hoses to be connected.
 4. Tanks into which cargo is to be received.
 5. Pumphouse and pumps to be operated.

6. Number of samples and the location where samples are to be taken.
7. Tests required.
8. Location of blinds, if used.
9. Line cleaning or displacement.

The pier shall be prepared to receive the ship. The supervisor shall make an inspection of all emergency equipment as well as all the tools and regular equipment to be used. The responsibility for safe docking rests with the ship, but shore personnel must assist in every way possible. The supervisor shall not allow a vessel to dock if any serious and unusual hazards are apparent. The berthing position of the ship should be spotted by the wharfman at the proper pier location so that the hose connections can be made properly without delay in accordance with previous orders and arrangements. The terminus of each mooring line at the bollard or belay pile should be a manila or synthetic fiber line or eye that can be cut in an emergency, unless other means of emergency release is provided. It is recommended that no ship shall be allowed to dock or moor adjacent to or within 200 feet of another ship which is transferring bulk cargo

MIL-HDBK-201B
23 September 1971

except by agreement between the depot officer, or supervisor, and the officer of the ship transferring cargo. If there appears to be a hazard, cargo transfer shall be interrupted until the second ship is safely docked or moored. (In particular, there is always the hazard of a flammable vapor-air mixture where gasoline or low flash jet fuel is being loaded and vapors are released at deck level.)

1. *Gangways*. Immediately after docking, the ship shall rig a gangway for safe access of petroleum inspectors or other personnel. If the movement of the ship does not permit this, special equipment may be used instead. Attendants for adjusting the gangway shall be provided by the ship. This requirement applies particularly to tankers and large ships where samples and gages are taken and witnessed by shore personnel. The ship's signal system used at the pier to regulate the operation affecting the transfer of product should be tested.
2. *Communications and Other Facilities*. The ship's officer should be informed of the facilities provided for fire protection at the pier and of the services available for ship's use, such as power, water, and steam, in case it is necessary to eliminate boiler and galley fires from the ship entirely. A portable telephone of approved type carried aboard the ship will increase the speed and safety of communications.
3. *Sampling and Testing Before Unloading*. Before unloading operations are started, local quality control personnel, or military petroleum inspectors, should take samples from ship's tanks in accordance with established procedures. Except in emergencies, all arrangements for the services of inspectors shall be made well in advance in order that there will be no loss of time. The shore gager should be familiar with the technique of drawing samples and gaging ship's tanks.
4. *Certificate of Readiness*. When a ship other than a U.S.S. ship, arrives to discharge cargo, the ship's master may serve the depot with a "certificate of readiness" to discharge. The time for calculation of demurrage charges is thus established when such charges are permitted by contract. Whether demurrage is involved or not, if for any reason it is impossible to start unloading a ship shortly after arrival, the depot commanding officer should be notified of the circumstances.
5. *Line Filling, Sampling, Gaging, Prior to Unloading*. The supervisor will escort the ship's officer to the tank farm to witness gages unless this verification privilege has been waived. The ship's officer should ordinarily be invited to inspect the diagram of lines and connections and to assure himself that valves or blinds are properly set in accordance with the diagram. He will not necessarily perform this verification himself.
6. *Duties of Ship Personnel*. Personnel required for hose handling and other operations aboard ship are those required by standard ship or naval requirements. It is generally the responsibility of ship personnel to perform all actual connecting and disconnecting of hoses aboard ship and accept the responsibility of the safe completion of this duty. In order to comply with safe operating procedure, the depot supervisor should inspect conditions ashore and aboard ship before operations are started. During the entire time of bulk oil transfer there will normally be at least one deck officer and one engineer officer on duty aboard ship. Obviously, this rule, applicable to the larger ships, is to be modified to suit the actual personnel handling receipts from small craft.
7. *Hose Watch*. When cargo is discharged ashore, it is customary for the ship to provide a hose watch aboard ship to stand by at all times for the purpose of watching for strains or chafing of the hose and to close the ship's valves.
8. *Unloading Operations*. Prior to unloading, the supervisor shall receive from the ship's officer, a certified copy of tests or a sealed sample of the oil taken at the loading point.
9. *Assignment of Personnel Ashore*. The supervisor should designate the assignment of regular shore personnel, and if needed, will arrange for extra labor to handle lines and cargo hoses. He will also arrange for special assistance such as tug or pilot if required to dock or release the ship from the pier. All

MIL-HDBK-201B
23 September 1971

gear necessary for docking the ship and receiving the cargo shall be ready for use on the pier.

10. *Filling of Lines.* Before the ship is docked, the pier pipelines shall be filled. It is impossible to obtain an accurate measurement of products received or issued unless the lines are completely full, or completely empty, and the exact line volume known. In case of emergency, it may be permissible to draw from the line between opening and closing gages if appropriate volume corrections are made.
11. *Rigging and Inspection of Hose.* Procedures for handling hose ashore is governed by standard practices. Before the ship docks, the designated hoses to be used shall be examined and raised in position on the hose support. If in use, the blinds on the wharf line connections should be removed and the shore ends of the hose bolted securely to the fuel line risers. Tank ships, fuel barges, and other vessels usually carry hose, but in order to save time, pier hose should be used whenever possible. Enough hose must be used to allow for a reasonable amount of slack to take care of local conditions of tide variations, weather, and layout. Too much hose may be undesirable, as it will retard the oil flow. Modern cargo hose is a strong, reliable product, but it will not stand long continued abuse. Spills and fires of the most serious nature have followed ruptures of hose; therefore, all personnel concerned should understand how necessary it is to follow safe hose handling practices. The hose connections should be made up with proper gaskets and a full complement of bolts. Most ships will be provided with American Standard Flanges (4-, 6-, or 8-inch) for hose attachment. These will present no problem. Some ships, however, may have other flanges either of foreign make or wholly anomalous drilling requiring adapters or C-clamps. Older ships may use the same drilling for both 4- and 6-inch flanges; for example, six 3/4-inch bolts on a 10-inch circle. The depot should have a set of straight and reducing adapter spools on hand to cover all normal requirements and several sets of bolts preferably of alloy steel. In no case, where less than the normal complement of bolts is employed, shall there be less than four bolts unless a camlock type flange or C-clamps are used. C-clamps, if used, must be verified either by test or calculation to be of adequate strength, and must be supplemented by at least two bolts to prevent the flange from sliding or twisting. C-clamps may be knocked off in an emergency, but this is a hazardous operation. Where conditions may require disconnecting during an emergency, patent quick-acting clamping devices such as those now available, may well be used.
12. *Hose-Handling Gear.* Hose-handling gear of a fixed type should be provided where feasible, especially for hose over 4-inch diameter. At piers used for general cargo, fixed type handling gear may not be permitted. In such locations small movable hose cranes may be used. Provision for proper hose handling gear is in most cases the responsibility of the shore organization. Hose-handling gear is not only a means of saving manpower, but is needed for supporting the hose during the entire time of the transfer and for slacking or lifting the hose to follow the ship's movement of drift, caused by the wind or changes of the tide.
13. *Service Connections.* Connecting the hose, making electrical bonds, and service connections, when needed for water, steam, or electricity may proceed concurrently with necessary gaging and sampling. If, for a logical reason, the ship's crew is unable to make up its own connection, the shore crew, by agreement, may make the connection for the ship's crew. Pressure gages should then be installed on the pier risers or pipeline. When gaging, and sampling operations are completed and preliminary examination of samples indicate that the cargo is in order, pumphouse and tank farm personnel will be notified that the ship is ready to unload and to standby for final valve settings and readying booster pumps as required.
14. *Notification to Start Unloading.* The ship's officer should formally notify the supervisor that the ship is ready to discharge, and the supervisor, in turn, should inform the ship's

MIL-HDBK-201B

23 September 1971

commanding officer that the depot is ready to receive. The commanding officer of the ship, or the depot commanding officer may require either or both of these notifications to be in writing. The pier valve is first opened. The ship's lines valves are then opened and the pumps are started, or if pumps are already started the bypass valves used in connection with positive displacement pumps already started are gradually closed. Centrifugal pumps may be started before the ship's valves are opened and the flow may then be controlled simply by opening the ship's line valves. The pressure should be built up gradually and the pressure gages on ship and pier carefully observed.

15. *Unloading Speed.* The wharfman will communicate with the pumphouse and tank farm personnel to ascertain that the booster pumps are performing properly, and that the oil is entering the correct tank. If the depth of liquid heel in the receiving tank is sufficient, he then may request permission to order maximum rate of flow. The wharfman may then order full rate of flow and the pressure will be raised to the allowable working pressure on the hose or to whatever lesser value the pumps can provide. Unloading should proceed without delay as ship's time is valuable. Safety rules must be observed.

16. *Check Gaging and Line Patrol.* Systematic gaging of the shore tanks shall be performed during cargo transfer as specified in the working orders. The lines shall be patrolled periodically as local conditions and possible hazards dictate. The discharge of cargo shall be stopped in case of a large oil spill at the pier, a fire on the vessel or pier, or in the vicinity of the shore lines, or in the tankage area. Discharge shall be stopped on the approach of an electrical storm when gasoline or jet fuel is being handled. On the occasion of such interruptions, the valves on the ship and pier shall be closed. If no immediate hazard appears, the hose may be left connected. If either the ship's officer or supervisor believes that there is a potential hazard, the hose shall be disconnected and drained and the main block valve on shore closed.

17. *Changing from One Tank to Another.* In changing the flow from one tank to another in the tank farm, it is not necessary nor usually desirable to shut down pumping operations, as such a shut down may not only cause delay but may offer an opportunity for errors. Before performing any switch of tanks, the tank field gager shall inform the pumphouse and pier personnel of his intention, designate the tanks that are then open to the line, name the tank he proposes to open, and the tank he proposes to close. The wharfman, likewise, shall request a slowdown in case the switch is apt to cause surge pressure on the hose, as in a switch to a tank of higher elevation.

18. *Change in Pump Operations.* The booster pumphouse operator shall inform the pier and tank farm personnel of any proposed shift in pump operation. The pier personnel shall inform the pumphouse in advance of any proposed slowdown or change of the ship's pumps. All tank changes and valve operations shall be performed slowly, and the pressure shall be watched during the operation. If possible, the wharfman shall be given a "standby" order from 5 to 10 minutes before the transfer rate is changed, stopped, or again started, and he in turn shall inform the pumphouse and tank farm personnel of any anticipated changes on the pier or aboard ship.

19. *Stripping Speed.* Before the final slowdown for stripping the last of the ship's tanks, it is often advisable to shut down the booster pumps and pump directly to the tanks, provided the opposing static head is not too great to prevent this. It is desirable before receipt of the cargo is fully completed, to take approximate final gages and compute an estimate of the cargo delivery in order that any large discrepancy may be determined and be investigated before the ship sails. This procedure is suggested also as a precaution against accidentally leaving some of the cargo aboard ship. When stripping ship's tanks, care should be taken to avoid discharging air unnecessarily into shore lines. Upon completion of the transfer the hose shall be disconnected and drained free of the

MIL-HDBK-201B
23 September 1971

product, half drums or pans being used to catch any spillage. If oil is left in the hose, the best means of draining is by the use of small suction pumps arranged to draw the oil from the hose and discharge into a pier drainage tank or preferably into the pier line itself. It is permissible to use compressed air for blowing fuel and diesel fuel out of the hose and into the pier drainage system or sump tanks or back to the ship. It is not safe practice to use air for blowing gasoline or jet fuel, therefore, using air for the displacement of gasoline or low flash jet fuel shall not be permitted. When the unloading hose has been disconnected and removed from the riser flanges it should be placed on the pier, and closures placed on both ends of the hose, then the hose shall be stored in a shelter or a sheltered hose rack. Under no circumstances shall oil be allowed to drain under the pier nor on the pier deck.

20. *Final Inspection of Ships Tanks.* The supervisor in company with the Armed Services petroleum inspector, if assigned, and the ship's officer shall inspect the ship's tanks to make certain that they are empty. Unless tanks are found empty after unloading, each tank or compartment involved shall be examined to determine the quantity of product remaining therein which cannot be pumped ashore. If it is impossible to get accurate figures by gaging, estimates will be made. Figures obtained and tank numbers involved will be made a matter of record.

21. *Closing Shore Tank Gages.* After required settling time has been allowed, closing gages on shore tanks, and samples of the oil received shall be concurrently taken and witnessed by ship's officer, referee, or authorized inspector, if required. The quantity of oil delivered into shore tanks shall be computed as soon as practicable, after final gages are taken. These volumes shall, at once, be corrected to the volumes occupied at a temperature of 60°F., for a final check against the quantities delivered by the ship. The supply officer or designated authority will then sign the acknowledgment of receipt if the figures are in order. Pier lines should then be drained if required

by local orders unless another receipt or issue is to follow shortly.

22. *Draining Pier Lines.* It is sometimes good operating practice to drain pier lines that will not be used for an extended period of time. However this is left to the discretion of the supervisor and local fire chief. This is accepted to mean all lines on the pier structure back to the first block valve on shore. As drainage and refilling of such lines may require a good deal of time and introduce other complications, the procedure should be held within practical limits when successive issues of the same product are expected. Drainage of pier lines is not ordinarily practiced at active military depots. Small return lines have been installed on some of the recently constructed oil installations for removing or displacing oil from the main lines on the pier. These are used in draining or line cleaning operations. Unless relieved, expansion of products in idle pipelines due to heating, usually by direct exposure to the sun rays, develops excessive pressure. It is the duty of the pier personnel to see that pressure relief valves are properly installed and are in good working order, to open manually operated relief valves when necessary, and to keep pressure gages on any filled but temporarily idle pier lines, and to observe them at frequent intervals.

23. *Defueling.* Defueling means the removal of fuel from bunkers and excess products from ships fuel tanks. Fuel returned by submarines or other craft should be segregated and quarantined in shore tanks provided for that purpose or quarantined in harbor barge tanks. Samples of the quarantined fuel should be taken and analyzed to determine quality and disposal action. This procedure is necessary to preclude the possibility of mixing contaminated fuel with on test product in storage.

24. *Defueling into Harbor Barges.* When necessary to defuel into harbor barges, the barge tanks should be inspected prior to refilling with on test fuel and returned to regular service. This procedure is necessary in each case where a barge has been used for defueling purposes.

MIL-HDBK-201B
23 September 1971

b. *Issuing*. Issuing fuel oils at a military fuel depot may include loading tankers but more often will consist of fueling naval vessels and loading harbor barges at pier or wharf. Fueling naval vessels at sea is not described in this Handbook.

1. *Loading and fueling*. The physical procedures for issuing burner fuel oils, diesel fuel oils, and even gasoline or jet fuels to harbor barges are the same in principle as those involved in loading tank vessels. The formalities are usually simplified on account of the smaller quantity of the delivery, but in order to detect possible contamination it is advisable to obtain samples from the barge tanks after loading operations. The witnessing of shore gages by the ship's officer is usually dispensed with, especially if the barge is operated by the same command as the depot. However, none of the safety precautions should be relaxed even though the quantities involved are smaller.

2. After filling the pier lines the shore tanks will be gaged, sampled and thieved for water. If a tanker is to be loaded, this gaging and subsequent tests will probably be witnessed by the ship's officer or his representative; otherwise gaging will be witnessed by depot personnel. The supervisor should inspect the ship's tanks in company with the ship's officer to assure that they are empty and clean and in condition to be loaded. Prior to loading JP-5 fuel, MSTs tankers and chartered tankers must have the tanks in which the JP-5 is to be loaded stripped dry and cleaned to remove residual rust contaminant and moisture. Except when necessary, due to structure or other operational considerations, these tanks should not be ballasted prior to loading JP-5 fuel.

3. *Loading Tankers or Barges*. Loading a tanker or barge involves the same general series of operations as unloading with obvious modification in sequence and with the following three important differences: the extra hazard of spilling oil overboard at the pier as a result of running the tanks over; the extra hazard connected with vapors of jet fuel or gasoline being discharged from the ship's tank vents; and the hazard incident to tank ships discharging ballast.

The fuel depot's service facilities and its personnel form a service organization. It is designed to provide on-test fuel without particular reference to its own convenience. To do this most effectively, however, it should have advance notice whenever practicable, particularly for large transfers.

4. *Need for Advance Notice*. Except in cases of emergency the depot should be notified of the ship's movements and loading requirements far enough in advance to permit the scheduling of shore operations. Advance notices should indicate the following:

- (a) Expected time of ship's arrival.
- (b) Product to be loaded.
- (c) Quantity to be loaded.
- (d) Tests of product required.
- (e) Amount and nature of ballast to be discharged ashore.
- (f) Cleaning operations that must be performed.
- (g) Any special services or unusual requirements.

5. *Plan of Operation*. The supervisor shall prepare a plan and schedule for handling loading operations, making all necessary arrangements for handling personnel, material, and equipment well in advance, in a manner similar to that previously described for receiving cargo. As soon as the tank ship is docked, the supervisor shall review the planned arrangements with the ship's officer and if modifications are necessary they shall agree to such modifications. If possible, the pier lines should be filled and samples taken and tested, as required before the arrival of the ship. All valves, on the shore lines pertaining to the operation, should be opened except those necessary to prevent cross transfer and the valve at the pier hose connection. General safety and fire precautions including any patrol required in the planned operations will be verified and procedures reviewed by shore representatives. The wharfman shall then notify the ship's officer of the shore's readiness to issue cargo. When notified by the ship's officer that the ship is ready to receive, the wharfman shall slowly open the pier valve at the hose connection. The pumps at individual tanks, or the

MIL-HDBK-201B
23 September 1971

booster pumps, if used, shall be controlled to avoid excessive pressure at the pier. Samples from the line and the ship's tanks should be taken periodically and tested during loading operations to assure that the product being received aboard the vessel meets the specification requirements.

6. *Speed of Operations.* When it is determined by the ship's crew that the oil is received into the ship's designated tanks, the ship's officer will approve full flow to the degree previously determined as safe for the ship in question. The wharfman will issue the instructions to the booster pumphouse and

tank farm personnel and stand by to observe the hose pressure and adjust the pier valve if necessary. Violent and sudden increases in flow that will cause objectionable surge pressure shall be avoided. Loading should then proceed at maximum allowable or available rate without delay until the time comes to "top off" the ship's tanks. Tanks are topped off when about 90 percent full. During the topping off of the tanks, the loading rate should be considerably reduced to avoid an oil spill or overflow. Any changes in pumping rates should be reported to the responsible ship officer immediately. (See Chapter 7 for hazards in loading jet fuel.)

SECTION VII. STORAGE

4.23 GENERAL.

This section deals with transfer circulation and water draw-off operations in connection with storage of petroleum products.

4.24 TRANSFERS.

Transfers of product from tank to tank in a depot are made for several reasons. It is advisable to keep several tanks filled with on-test stock, ready for making large issues on short notice. At the same time, other tanks should be kept emptied in order that a cargo may be received with a minimum of tank switches. This can be accomplished by emptying the tanks completely, that is, stripping them without intermediate refilling, after most of the stock in the tanks has been withdrawn. This is the proper and recommended procedure to follow, to avoid the unnecessary accumulation of sludge or bottom sediment or other off-test stock.

The policy of "first in- first out", that is the issue or use of oldest stocks first shall be the normal method of operation. Unnecessary mixing of products from different cargoes shall be avoided.

In order to fill tanks to predetermined fill levels and to avoid overflow, the rate of flow should be reduced as the liquid level approaches the fill height limit. If the rate of flow cannot be reduced, do not attempt to fill the tank to the maximum capacity.

Whenever a tank is drawn down to the lowest level practical for issuing, the remainder of its content shall

be transferred to a partly filled tank, the contents of which are preferably from the same source and receipt. Such stripping transfers will be made at a suitable low rate, and at times when the depot would otherwise be idle. This transfer may or may not include the product in the tank below the level of the service suction, depending on whether this product is sufficiently clean and dry. When feasible, the entire contents should be transferred. This will tend to avoid the gradual collection of wet and off-test tank bottoms. If the product below the service suction is found to be off-test it shall be pumped into a sludge tank.

If the lower levels of several tanks should show excessive water, or other objectionable qualities, all of the off-test stock should be accumulated in a single tank where it can be dealt with in due time. If it is only off-test to a moderate degree, it may be reclaimed or consumed by facilities whose requirements are not critical. Allowing off-test bottoms to accumulate in a number of tanks reduces the available storage capacity for clean product and increases the possibility of contamination.

Transfers will be made with the tank pumps where available; otherwise by gravity, or through the central pumphouse. The method used will be determined by the design of the piping system. When off-test stock is transferred from any line which is to be used later for issuing, it must be displaced with clean stock, promptly and completely. Unless the tanks involved are adjacent, two men will usually be required at the tanks to make a transfer. In no case should one man

MIL-HDBK-201B
23 September 1971

be permitted to perform a transfer alone without periodically reporting to his supervisor, by telephone or otherwise. All pertinent facts concerning transfers should be entered in the log.

4.25 CIRCULATION.

Where individual tank pumps are provided or there are two paths of flow from each tank to a central pumphouse, the contents of the tanks may be circulated either to eliminate slight stratification, or for heating. Prior to such an operation, any free bottom water must be drawn off to avoid mixing it in with the product.

Where means for circulation of individual tanks are not provided, mixing, when required, may be accomplished by the transfer of oil from one tank to another.

4.26 WATER DRAW-OFF.

It is imperative that the operating tanks contain only dry, on-test stock. Every reasonable effort should be made to prevent the delivery of free-water, especially saltwater, to any tank.

Where water is known to exist in "birdbaths" of otherwise flat bottomed tanks or that water draw-offs are not at the low points, additional sumps and 3/4" water draw-offs will be considered for installation of

next tank opening for internal inspection. On daily water draw-offs, operate the valve so that water is drawn off slowly into an open catch basin or otherwise provided facility, where it may be observed continuously. Tank farm drains should not discharge into public sewers or waterways without passing through a separator of some type. This separator may merely be the baffled outlets in a series of diked ponds or a regular concrete, gravity type separator. The amount that can be removed will approach a practical limit if the operation is performed very slowly.

Bottom water can be more completely drawn off from diesel fuel oil tanks than from Navy Special fuel tanks. Diesel fuel oil filters and clarifiers are not adequate to cope with large slugs of water, therefore, special care must be exercised to remove any accumulation of water from diesel fuel tanks before it rises high enough to be drawn into the regular outlet.

Extreme care shall be used in connection with jet fuel tanks to eliminate water contamination.

4.27 CHANGING TANK SERVICE.

Serious contamination of product can result upon changing the service of a tank from one product to a different product. Prescribed procedures must be followed to prevent such incidents. Appropriate departmental instructions must be followed in changing tank service.

SECTION VIII. PACKAGED PRODUCTS

4.28 GENERAL.

This section deals with reclamation and storage of petroleum containers, filling of drums and storage of packaged petroleum products. It is necessary that these operations be carried out properly to:

- (a) Insure maintenance of product quality.
- (b) Insure safe operations.
- (c) Insure full utilization of equipment and product.

4.29 RECLAMATION.

All drums must be inspected carefully prior to filling in order to assure that product will not be contaminated. Those drums not suitable for immediate filling should be screened in accordance with the

criteria established by the cognizant service to determine if they can be reclaimed. Used containers with the following defects are normally rejected and not reconditioned:

- a. Any surface completely penetrated by rust.
- b. Punctures exceeding 3/4 inch in diameter.
- c. Bodies, crushed or badly distorted.
- d. Splits, except in side seams.
- e. Loose, dented, or cross-threaded flanges.
- f. Galvanized or zinc coated.
- g. Bilge barrels.
- h. Drums with side openings.
- i. Drums that previously contained asphalt or paint.

MIL-HDBK-201B
23 September 1971

- j. Any other obvious defect that is just cause for the container to be set aside as one which cannot be satisfactorily or economically repaired.

Drums suitable for reconditioning are normally reclaimed by one or more of the following processes:

- a. Dedenting.
- b. Removing of exterior or interior rust, clingage, and material.
- c. Chime straightening and rescaling.
- d. Testing and inspection.
- e. Application of rust-preventive oil.
- f. Inspection and insertion of plugs and bungs.
- g. Painting exterior of drum.

Cleaning, drying and preservation of drum interior are particularly important in preserving the quality of products to be stored.

4.30 DRUM AND CAN FILLING.

Whenever feasible the operations of filling drums or other containers should be carried out far enough from other activities to avoid damage to the latter in case of spills or fires. This may not always be possible. Extra operating precautions will therefore have to be commensurate with the risk. It is equally important that flammable vapors from other activities or sources be kept out of the filling area. Filling equipment should be designed and located to permit free movement of operating personnel and to take advantage of the maximum amount of natural ventilation. If natural ventilation is insufficient, artificial ventilation must be installed. If forced ventilation is used, the outlet from the fan ducts discharging possible vapor-laden air from a building should be directed upward. The lowest point of fan outlet should not be less than 10 feet above an adjacent opening into a building and preferably 20 feet above the surrounding grade. There should be no untrapped drains within any such building nor in the surrounding area, nor any lower ground area, pits, or basements into which flammable liquids or their vapors may collect in case of leaks or spills. Provisions should be made for hosing down the floors at regular intervals. Wood floors should not be used in filling rooms. Prior to filling containers, it must be deter-

mined that the product to be filled is satisfactory and also that filter separators where necessary are available through which product will be processed prior to filling of the containers. After filling, 55-gallon drums should be rolled on their sides a sufficient distance to detect possible leaks around the bungs or chimes. A sufficient number of 5-gallon containers should be placed head down during filling operations to assure that closures are properly seated and leaks in the upper chimes are detected. All drums should be stenciled with complete information in accordance with Military Standard MIL-STD-290.

4.31 STORAGE OF PACKAGED PRODUCTS.

- a. *General.* Prior to deviation from storage practices prescribed herein, due consideration should be given to the following factors, as applicable: type of product, type and condition of containers, availability of space and equipment, natural and man made environment and costs.

- b. *Site Selection.* A level site should be selected that is not in or adjacent to a congested area, with the contour of terrain being such that it will confine spillage and permit recovering of fuels and prevent flow into open streams. DRAINAGE INTO ANY SEWER SYSTEM IS PROHIBITED. An area with a cinder base, marsh, or waste land overlaid with peat and usually more or less wet will not be used when other terrain is available. Consideration will also be given to direction of flow with the main outlets so located that flow is away from a congested area and toward a harmless area where fire extinguishing agents can be applied enroute or at destination. An adequate supply of water for fire fighting purposes should be taken into consideration in the selection of this site. The drum storage area should be located or arranged so that escaping flammable vapors normally flow away from operational areas and sources of ignition. Depressed areas should be avoided because dangerous vapors tend to remain in them. Petroleum vapors are heavier than air and tend to lie in a stream less than four feet above grade and flow toward lower ground much as liquid flows to a lower level.

MIL-HDBK-201B

23 September 1971

c. *Storage of 55-Gallon Drummed Petroleum Products.*

1. *Outdoor Storage.* When covered storage space is insufficient for storage of all packaged products, products in 55-gallon drums may be stored outside. This practice is common in field installations. The drums should be placed horizontally (on sides) in double rows, butt to butt, with closures (bungs and vents) facing outward and with liquid pressure on the closures. If stored on ends, the drums collect rain water, which rusts the tops of the containers and may seep through and contaminate contents. Corrosion and oxidation are also greatly diminished by laying drums on their sides. The closures are turned outward to facilitate the detection of leaks and prevent a leaky drum being shipped. To permit efficient operation of drum handling attachments, or if the condition of drums is such as to require closer inspection of butts and chimes, the drums of each single row comprising the double row may be spaced approximately one foot from opposing drums. Areas of high humidity and salty atmosphere accelerate corrosion, and drums stored in such areas shall require more frequent inspection than low humidity areas. For low flash products the rows of drums should not be more than 35 drums long. The drums of each superimposed tier of drums should be nested between drums of the supporting tier. The second tier should contain 34 drums and the third tier 33 drums; thus, the double row, or unit, should contain a total of 204 drums. For high flash products the quantity of drums in a major storage division can be doubled either by increasing the number of sections or the height of the stack to 6. To insure drums against damage from rolling, cross blocking every fifth drum should be required and, in addition, the ends of the bottom tiers will be braced. The bottom tier of drums should be placed on not less than 2-inches by 6-inches, or other comparable dunnage running parallel to the length of the rows. Occasionally, drums may be placed on special drum pallets, which allow four 55-gallon drums to be placed on their sides on each pallet. Pallets should be constructed

to prevent drums from rolling. Stack pallets one over the other with drum closures toward aisles. No end braces are necessary for palletized stacks. Aisles between double rows should normally be 10-feet. The aisles may be reduced to 4-feet where materials handling methods will permit. The physical layout of the storage area within the limitations specified in this section should be as prescribed by the military services. Each major storage division where low flash product is stored must be surrounded by a dike at least 18-inches high, assuming the terrain to be practically level in order to prevent burning liquids from flowing to the adjacent division, buildings, storage areas, or waterways. In any case, the dikes should be sufficient to retain all of the liquid contents of drums stored in the division and provide for a free board of not less than 6-inches. Access roads should be provided with ramps or graded to allow entrance of materials handling equipment into the dikes areas. Drainage should be accomplished by use of clay or metal pipe of sufficient size placed through the dike at the lowest point to insure an immediate runoff of surface water. The aperture should remain closed except when it is necessary to remove surface water.

2. *Covered Storage.* Clearances of at least 100 feet should be maintained between warehouses and other buildings, spark producing equipment, or fires of any kind. Warehouses should be constructed of fire resistant materials and should provide overhead clearance to permit stacking of containers to a height of at least 12-feet. The floor should be constructed of concrete and should be capable of supporting the estimated floorloads. If petroleum products are to be stored in buildings having more than one floor, they should be stored on the ground floor only. Provisions should be made for a good distribution of water in case of fire. Overhead sprinkler systems should be installed whenever possible. Portable fire extinguishers designed for use in petroleum fires should be available. Storage areas in each warehouse should be planned so that products may be segregated into sections.

MIL-HDBK-201B
23 September 1971

Sufficient space should be provided for aisles to permit inspection of supplies and to permit fighting of fires that might occur. Facilities should be available so that vehicles may be loaded and unloaded with a minimum of confusion. Curbs should be placed around each section of containers to prevent flow of spilled liquids to other sections of the warehouse. Roadways and parking space should be provided within the warehouse area to allow sufficient movement of vehicles through the area. Layout of sections and stacking height depend upon warehouse design, available storage space, load capacity of the floor, and available materials handling equipment. The primary objective in the arrangement of containers is to store the maximum quantities of products in a limited space while maintaining fire control and providing ease and safety in handling these containers. The entire stock of one product should never be stored in one section of warehouse or in a single warehouse.

d. *Storage of Products in 5-gallon Military Gasoline Containers.* Filled 5-gallon containers are normally stored in outdoor storage areas. To conserve space and to provide stability of stocks, filled 5-gallon gasoline cans should be stacked in pyramids, unless cans are palletized. To stack cans in pyramids, proceed as follows:

1. Lay out a 50-foot square.
2. Build a partial flooring for first tier of cans by laying out rows of 2- by 6-inch lumber or other comparable dunnage and tying it with wooden strips or boards. No dunnage is necessary between tiers.
3. Beginning at one corner of the square, place 86 cans side by side along one side of the square. Place cans 6-inches from edge of dunnage and allow 1/2-inch expansion space between the cans.
4. Place a row of 43 cans end for end, with sides facing aisle, along adjacent side of square to form an "L".
5. Place three rows of cans within the "L".
6. Place a second tier of cans on top of the first. Indent the second tier on both sides one-half can so that each can in the tier rests on 4 cans.

7. Place a third and fourth tier on the stack, indenting each tier as described in 6 above. Normally do not stack cans more than four tiers high. Local conditions may warrant higher stacking.
8. Continue building the pyramid outward until the entire 50-foot square is completed. The first tier should contain 3,698 cans, the second tier 3,570 cans, the third tier 3,444 cans, and the fourth tier 3,320 cans, totaling 14,032 cans in the section.

Filled 5-gallon cans may be stacked vertically when cans are palletized and fork-lift trucks or cranes are used. To stack palletized cans vertically proceed as follows:

- (a) Lay out a 50-foot square section; if necessary, adjust size of section to accommodate a definite number of pallets. Pallets in general use measure 32 by 40 inches, 40 by 48 inches, and 48 by 60 inches. Use only one pallet size in a section. It is not necessary to construct a floor for the containers; however, a suitable foundation material should be used.
- (b) Place cans upright on pallet and group them close together, allowing an even border around pallet. Terrain and equipment limitations must govern the number of tiers or cans on pallets. Size of the pallet will determine the number of cans to be included in the tiers.
- (c) Start at one corner of the section and place several pallets of containers along adjacent sides of the section. Pallets should be as close together as possible.
- (d) Place additional pallets of containers directly over the first tier until the desired number of tiers is reached. Palletized cans may be stacked higher than single cans, but available handling equipment and stability of stacks must determine the number of tiers.
- (e) Continue building stacks until the section is completed to the desired height before the next stack is begun to avoid obstructing the range of the truck or crane.

MIL-HDBK-201B

23 September 1971

e. *Storage of Packaged Lubricants and Greases.* All lubricants and greases in packages other than 55-gallon drums should be under covered storage. General instructions for covered storage are contained in 4.39(c)(2). Although packaged lubricating oils and greases are normally stored under cover, they may be stored outdoors when storage buildings are unavailable and containers are protected from water and heat of sun by fire retardant tarpaulins. The stacking area should be laid out to provide for segregation of products into sections. The lubricants should be stacked on pallets or adequate dunnage. If stored outdoors stack cylindrical 5-gallon oil cans in an inverted position, with closures on the bottom. Cans may be stacked vertically or in pyramids. Stack all containers other than 55-gallon drums and 5-gallon oil cans upright.

f. *Water in Packaged Petroleum Products.* Many petroleum products, though meeting specification requirements, contain dissolved water. Normally, as product temperature increases, the capacity for taking on dissolved water increases. Conversely, this capacity decreases as the product temperature diminishes and dissolved water separates out as free water. Water also enters packages, which are not hermetically sealed, through breathing action caused by temperature changes. Free water from these two sources often causes the interior surfaces of containers to rust. The Military Services have recognized the aforementioned phenomena and have issued applicable instructions in respective service publications. These instructions should be strictly adhered to in the servicing of packaged petroleum products.

4.32 STORAGE OF EMPTY CONTAINERS.

a. *General.* Empty containers should be protected from mechanical damage by careless handling.

and from contamination of interior by dirt, water, and other extraneous matters. Tightly closed containers will retard interior corrosion to a great degree. New or reconditioned containers received for storage will have no product markings thereon. These containers should be inspected periodically to insure their usability at all times. Containers evidencing interior or exterior corrosion should be removed for reclamation. Empty containers previously containing products should be treated as explosion hazards and handled accordingly prior to reconditioning. Closures should be tightly closed, as an open bung or vent emits hazardous vapors for some time after removal of product. Economically reparable containers will be salvaged.

1. *55-gallon Drums.* Empty drums may be stacked by any of the methods prescribed for filled drums but without height limitations.

2. *5-gallon Cans.* Empty containers may be stacked by the same method prescribed for filled cans but without the height limitations. Occasionally, empty 5-gallon gasoline cans (military type) are strapped side by side in groups of five. Those groups may be placed on pallets with the cans resting on their bases or their sides. Cans strapped into groups may be stacked vertically without the use of pallets; but dunnage must always be used between the bottom tier and the ground, and containers should not be stacked so high as containers stacked by other methods, unless shoring is placed at ends of each row to prevent stacks from slipping. Filler plugs must be tightened before cans are stacked.

SECTION IX. PRODUCT MEASUREMENT AND SAMPLING

4.33 GENERAL.

Product measurement consists of two separate operations. One is the gaging operation, which measures the height of product in storage tanks, depth of water (if any), and the product temperature.

The other operation is the calculation of the quantity of product at 60° F. This involves the use and application of the raw gage data, tank gage tables, and temperature correction factors. For inventory purposes, the line capacities, always computed at 60° F.

MIL-HDBK-201B
23 September 1971

must be accounted for whether the lines are empty or completely filled when inventory gages are taken. Product sampling consists of obtaining representative portions of the material sampled. Since samples are used to determine the test characteristics of the product sampled, a truly representative sample is most important. Techniques required to obtain representative samples vary depending upon the type of product and container holding the product. Product measurement and sampling procedures are outlined in detail in ASTM Manual entitled "Measurement and Sampling of Petroleum and Petroleum Products." (See Appendix B.)

a. *Product Measurement.*

1. *Gaging Operations* The importance of accurate gaging procedures cannot be over-emphasized. At most military fuel activities, it is necessary to train and indoctrinate new men as they are assigned. Vigorous steps should be taken to be sure they receive adequate and accurate instructions. Accepted gaging and sampling procedures are described in this section. It is realized that special conditions do arise which might make an unusual gaging or sampling procedure necessary. Gaging should be prohibited during electrical storms or extremely high winds.

2. *General Rules for Shore Gaging.* The frequency of taking tank gages varies with the activity of the depot. All gages are to be taken manually, unless otherwise directed. The following suggestions are to be construed liberally, but are practical minimums.

- (a) Nonworking tanks should be gaged at least once a week.
- (b) Tanks first filled, or filled after having been empty for some time, should be gaged once a day, until it appears that there is no leakage.
- (c) In case the gaging record of any tank appears irregular, all other tanks that may be affected by cross transfer shall be checked immediately.
- (d) Every tank, that is apt to be worked or issued from during the day, should be gaged at the start of the day.

(e) Tanks that may be used to receive incoming cargo shall be gaged in advance. Such gages may be witnessed by a representative of the ship and must be verified by two men at the depot.

(f) To insure against errors because of liquid surface agitation, the final official gage after discharge of cargo should be deferred for 12 hours. A preliminary check should be taken 30 minutes after receipt. If it is not practicable to wait for 12 hours, the official gage may be determined by any 2 successive gages, taken at 30 minutes interval, that agree.

(g) Tanks involved must be gaged before and after any issue or transfer. Such gages shall be verified by a second man. The agency receiving the issue may verify the gage, or it may be verified by an inspector acting for the receiver of the issue. In many cases, this outside verification will not be practicable.

(h) When a depot loads tank ships for off-shore delivery, gages should be witnessed by an inspector.

3. *Running Gages.* Running gages (without taking temperature or witnessing) for verifying rate of delivery, and the rate of filling tanks, may be read on automatic indicating gages where available. Unless otherwise directed they shall be taken as follows:

(a) Immediately after beginning of receipt or issue, and as frequently as necessary, to insure that product is entering or flowing from the correct tank.

(b) At the end of the first hour, check liquid level in other tanks served by the pipeline in use.

(c) After first hour gages, if conditions are normal, take gages every hour thereafter, as long as there is a certainty of there being room for more than 1 hour's delivery at the current receiving rate in each tank involved. If any valve switch or change is made that might result in an increase in the rate of flow, gages shall be taken at shorter intervals, until the new rate of flow is established.

MIL-HDBK-201B
23 September 1971

- (d) At successively shorter intervals, as the liquid surface in a tank approaches the allowable liquid height; generally the length of interval should not exceed the time estimated to fill two thirds of the remaining outage in any tank.
- (e) Gage tanks that might be erroneously receiving or discharging liquid whenever this suspicion appears to be justified.
- (f) As requested, by the foreman or wharfman to verify rates of receipt or issue.

Gaging is performed with a regular steel tape marked in feet, inches, and eighths of inches. Tape markings take into consideration the length of the bob. Subsequent to a receipt or issue, the receiving or issuing pipeline system should be completely filled with fuel by pump pressure or gravity pressure or by circulation and the tank valve should be closed while the opening and closing gage is taken. The valves of the interconnected tanks should remain closed until the tanks involved are gaged. This procedure is necessary to insure against accidental cross transfers while gaging, which would obviously result in false gages. The same gage tape and bob should be used for opening and closing gages of each tank.

The gager of an aboveground steel tank shall not stand where his weight will affect the position of the gaging height reference mark.

If gages cannot be verified by two men, a single gager should check his own gaging accurately. This can be accomplished positively by taking both innage and outage gages, utilizing the fixed reference height, assuring by subtraction that the two resultant measurements are identical, and immediately recording this verified gage in the gager's field book. Where two or more men verify gages, the gaging must be continued until an agreement is reached.

- 4. *Gaging Conventional Type Tanks--(fixed roof)*. Manual gaging is the accepted and most accurate method for determining quantities of petroleum products transferred between shore facilities and vessels.

Gaging may be done either by the "innage" or the "ullage (outage)" methods. Ullages are normally used on ship's tanks, and innages are commonly used in gaging barges and conventional type shore tanks. However, it is sometimes advantageous to use the ullage method on shore tanks, for example, when the water bottom is frozen or partially frozen or when the tank bottom is out of level, particularly the section beneath the gage hatch. Further, it is quicker and cleaner, especially in the measurement of black oil, since it is then not necessary to lower the bob to the bottom of the tank and then wipe the entire length of the tape. Innage gages must be taken where an exact reference mark cannot or has not been established or when requested by an inspector. When outage gages are used, the conversion tables are so calibrated that when the gages are applied to them, the innage or contents of the tank will be readily obtained. Both methods are described below. A definite reference mark should be established on the gage hatch of each tank whether innage or outage gages are to be used. This mark shall be a horizontal line cut in the rim of, but not on the seat of, the gage hatch, or a metal angle permanently fixed (not adjustable) below the seat of the gage hatch. The gaging reference mark on floating roof tanks may be affixed to the gaging platform when gaging is performed from that position. The distance from the bottom of the tank to the reference mark shall be measured while the tank is approximately half full and after the tank has finally settled. Reference height measurements shall be made only by authorized personnel. The measurements shall be made by lowering the bob through the gage hatch until the tip of the bob just touches the bottom of the tank. An innage bob and tape (see figure 6) should be used for this measurement, and care shall be taken that the bob does not rest on a rivet head, pipeline, or other projection on the bottom of the tank. The tape reading at the reference mark is the reference height. The reference height shall be checked for accuracy whenever a tank is emptied, altered, or cleaned. Additional spot checks shall be made periodically on the tanks in service.

MIL-HDBK-201B
 23 September 1971

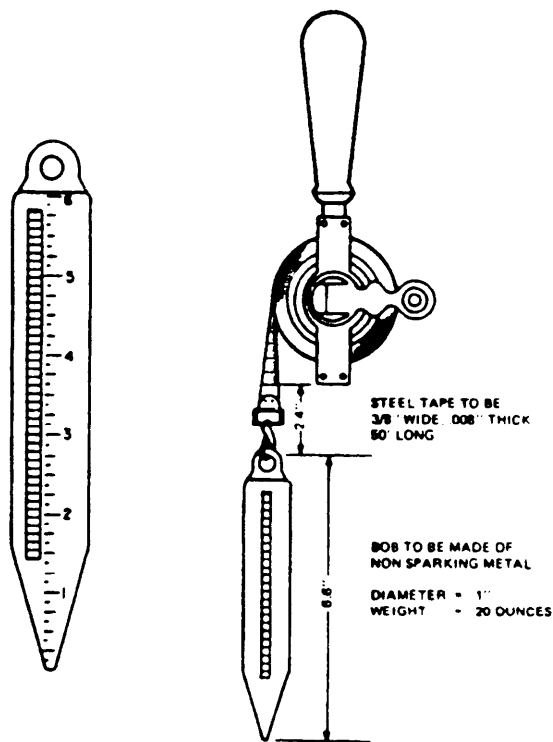
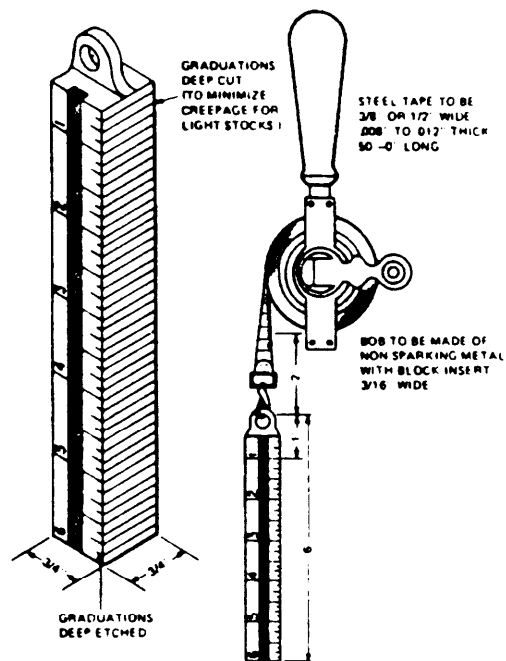

Figure 6. Bob and tape (innage gaging).

5. *Outage Gaging Procedure.* An outage gage is the measurement from a reference mark at the top of the tank down to the liquid level. Outage equipment should be used. The outage bob shall be lowered through the gage hatch until an oil "cut" is obtained on the bob (see figure 7). A tape reading shall be taken at the reference mark. The tape shall be withdrawn and the "cut" on the bob read. Both readings shall be recorded in the gager's field book. A convenient method of checking the outage measurement is to make the check reading exactly 1" lower; for example, original tape readings at reference mark equals 15'6", and the bob reading equals 3 3/4". The check measurement shall be made by lowering the bob so that the tape reading at the reference mark becomes 15'7". The bob reading should then be 2 3/4". In both readings the total outage equals 15' 9 3/4". If only innage bobs are available for taking outage gages, the procedure is as follows: The tape is gradually lowered and swung back and forth until the tip of the bob breaks the surface and causes



THIS DESIGN IS RECOMMENDED FOR GENERAL USE WHERE A LARGE NUMBER OF GAUGES ARE TAKEN ON VISCOUS STOCKS. A BOB WITHOUT THE DEEP CUT GRADUATIONS MAY BE USED.

Figure 7. Bob and tape (outage gaging)

a ripple, which may be observed by sunlight or the use of a flashlight approved for use in explosive atmosphere; at this point, the tape is held steady and a reading is taken at the reference mark. The "cut" of oil on the bobs is then subtracted from the total reading to determine the outage, and this measurement is applied to the tank calibration chart.

6. *Innage Gaging Procedure.* To determine a tank innage, the distance from the exact gage striking point at the bottom of the tank to the surface of the oil shall be measured. Innage equipment should be used (see figure 6). The innage bob shall be lowered through the gage hatch until the tip of the bob just touches the bottom of the tank. The oil "cut" reading on the tape represents the innage. A tape reading shall also be taken at the reference mark, and this reading shall be checked against the reference depth to insure that the bob is not resting on some projection on the bottom of the tank. Where the oil "cut" on the tape is not readily legible, an approved oil-finding paste shall be

MIL-HDBK-201B
23 September 1971

used so that the gage may be read accurately. In no case shall chalk or oil be used for this purpose.

7. Gaging Floating Roof Tanks. Gaging procedures for floating roof tanks differ from gaging procedures for conventional type tanks because the hazard of the accumulation of vapors to produce a toxic or flammable atmosphere in the space between the top of the floating roof and the top of the tank shell, and the displacement of stored product due to the weight of the roof when the roof is floating. The following precautions should be taken by those who gage floating roof tanks.

- (a) Gaging should be performed by two men, one remaining on the top platform, while the other descends to the floating roof.
- (b) No one should be permitted on the roof while product is being pumped into or out of the tank.
- (c) No one should be permitted on the roof when it is resting on its legs except immediately after the completion of pumping-out operations, which have lowered the roof from a floating position to a position where the roof is resting on its legs. Gaging under these conditions, however, should be avoided insofar as practicable.
- (d) When a roof is refloated after having rested on its legs, the atmosphere immediately above the roof may contain a dangerous concentration of vapors. Before descending to the roof precautions should be taken to assure that the atmosphere on the roof is free from toxic vapors. The gager may descend to the roof if it is within 6 feet of the top of tank shell and a considerable period of time has elapsed after pumping has stopped to permit the dissipation of the vapors from the atmosphere above the roof. No one should be permitted on the roof and all gaging must be done from the top platform if the roof has not been raised to within 6 feet of the top of the tank, unless the atmosphere immediately

above the roof has been checked with a combustible gas indicator and the vapor-air concentration is found to be safe.

- (e) When the roof is floating and the normal operation of the tank does not permit it to rest on its legs, it is permissible to descend to the roof regardless of the level of the roof below the top of the shell. Caution should be exercised however to insure that the atmosphere above the roof is not hazardous. Before gaging it must be determined that the roof is level and is fully floating, or at rest on its bottom supports. Accuracy is dependent upon this knowledge because the weight of the roof displaces an amount of liquid which varies with the gravity and temperature of the fuel and with the extent to which the roof is supported by the liquid. Without making corrections to adjust for these factors, large gaging errors can be incurred. Unless the partial displacement zone has been liquid calibrated, the actual gaging measurement will reflect a false liquid level except when the roof is fully resting on its bottom supports. Water, snow, or other foreign material on a roof which is floating shall be removed prior to gaging. Where cleaning of roof is impracticable, the gager shall enter a record of the roof condition in the gager's field book when opening and closing gages are taken. In this case, it is helpful to also note effects of similar roof conditions on an adjacent floating roof tank that has had no "ins" or "outs".
- (f) Where more than one gaging hatch has been provided on a floating roof, gages should be taken from each hatch and averaged for maximum accuracy.

8. Gaging Procedure. Innage gages shall be taken before and after delivery, or receipt by lowering the gaging bob from the gage hatch into the gaging pipe until the tip of the bob just touches the bottom of the tank, i.e., reference point. The product cut on the tape

MIL-HDBK-201B
23 September 1971

represents the innage. A minimum of two readings should be obtained. In the event these do not agree, a third will be taken and recorded. The average of the readings taken will be used as the gages for inventory purposes. At the time of delivery, although the roof is fully floating at both the opening and closing gages, deductions for the weight of the roof will be included in the gage calculations. If a considerable amount of snow or ice should collect on the roof during the time of delivery, the amount of product displaced by the roof will be greater on closing than it was at the opening gage, due to the added weight on the roof. The extra amount of product displaced can be determined by taking an ullage gage from top of the gage hatch to the surface of the product. (This measurement will be made at the time opening and closing gages are taken.) If this measurement shows a difference between the opening and closing gages, such a difference shall be considered in the gage calculations. The gage reading will be inaccurate regardless of the procedure used if the roof tilts due to uneven snow or ice load. While receiving products into a tank, unless the tank roof is resting on its bottom supports at the beginning of the delivery, adjustments for the weight of the roof shall be made on opening and closing the gages. In case of receiving product into a partially filled tank, the amount of product displaced by the roof may be affected by a difference in the specific gravity of the product stored in the tank and that of the incoming product, or other causes; therefore, it will be necessary to make corrections for the weight of the roof in the opening and closing gages of any receipt into a floating roof tank. These corrections should be in terms of gravity of liquid in which roof is directly floating in each case. When a roof is only partially floating, it is impossible to compute its true displacement, therefore, the liquid volume at this small range of depth in the tank can be only estimated. Therefore, this situation should be avoided by either floating the roof completely or drawing the liquid away from contact with the roof before gaging. Gaging of tanks with partially floating roofs can be

accurately accomplished if the partial displacement zone has been liquid calibrated.

9. *Gaging Variable Vapor Space Tanks.* The general gaging procedure outlined in the following paragraph applies to the breather, balloon, and gasometer "lifter" roof type tanks.

Gages should be taken as soon as practicable after receiving or issuing cargo. However, after deliveries to the tanks have been made, sufficient time shall be allowed for settling, air expulsion, etc., a settling period of at least 1 hour is recommended before closing gages are taken.

On variable vapor space tanks, the gaging pipe or well is fastened to the underside of the roof and extends nearly to the bottom of the tank. Since the tank is closed, the surface of the oil in the gaging pipe or well is not at the same level as the surface of the body of the oil in the tank.

This condition is due to the difference between the pressure in the well and the pressure in the space above the oil stored in the tank. This difference in pressure is determined by the use of a manometer which is connected to the roof of the tank. The gaging procedure consists of lowering the gaging bob into the gaging pipe until the tip of the bob just touches the bottom of the tank. The oil cut on the tape represents the innage and should be recorded in the gager's field book. Some tanks are equipped with built-in mechanical tape gages. These devices may be used for check or running gages, but should not be used for final determination of product received or issued. As previously stated, hand gaging is the accepted and the most accurate method of determining such quantities of petroleum products. A manometer reading shall be taken and the pressure or vacuum (in inches) as indicated by the manometer shall also be entered in the gager's field book with each opening and closing gage. Innage gages determined on variable vapor space tanks must be corrected for the pressure or vacuum on the tanks as indicated by the manometer. If the manometer is filled with a liquid other than the product in the tank, an additional adjust-

MIL-HDBK-201B
23 September 1971

ment may be necessary. If the tank is under pressure, the correction is made by subtracting the manometer reading (in inches) from the gage, or, by adding the manometer reading if a vacuum is indicated.

10. *Gaging Tank Cars.* Equipment shall consist of a "short" pole sometimes referred to as a "dorris gage" for measuring shell outages or dome innages and a "long" pole for measuring free water or residue innages. The short pole is 36 inches long graduated in 1/8 inch divisions with the "0" mark 12 inches from one end, a brass angle is attached to the pole 3/8 inch above the "0" mark to allow for the nominal shell thickness so that all measurements start from the underside of the top of the shell. The long pole is 10 feet long graduated in 1/8 inch divisions for the first 12 inches and 1/4 inch divisions for the remaining portion of the pole. The bottom end of the long pole is equipped with a 4 inch non-spark tip to protect it from damage and to aid in penetrating heavy residues. To gage the contents of a car, the short pole shall be inserted through the dome hatch with the short end down and the brass angle placed on the edge of the tank shell which protrudes into the dome.

This gaging point shall be the highest point of the tank shell on a line with the longitudinal center of the car. Care shall be taken that the angle on the pole does not rest on a rivet head if the shell plates overlap at this point.

The pole shall be withdrawn and the oil level "cut" read on the scale to the nearest 1/8 inch. If the cut is below the "0" mark, the reading shall be recorded as "shell outage" and if the "cut" is above the "0" mark, the readings shall be recorded as "dome innage." Gages and temperatures should be entered in the gager's log and excessive "outages" brought to the attention of the supervisor. Tank cars shall be on level trackage when being gaged.

11. *Measurement of Temperature.* The thermometer most commonly used for taking temperatures in tanks is a mercury type having a range of 0° to 180° F., marked in 1° F. increments, mounted on a wooden back with an open metal cup surrounding

the bulb. For determining the temperature of heavy fuel oil, or when accurate results are wanted more quickly in a tank containing a product that is not at the same temperature throughout, a special thief thermometer should be used. Since the correct average temperature is required for calculation of product, it is important the temperature be determined accurately. Thermometers must have attained the temperature of the product before reading. Temperatures must be recorded to the nearest degree Fahrenheit. Readings should be made as rapidly as possible after the thermometer is removed from the liquid to minimize the effects of atmospheric temperature. Before initial use and at least once a year, each thermometer must be standardized in a laboratory by comparison with a standard thermometer. Thermometers are precision instruments and should be handled carefully and examined frequently. Thermometers with broken mercury column should never be used.

The thermometer is usually suspended at least a foot from the shell, but where deck openings permit, the temperature should preferably be taken at a point near to one-third of the radius of the tank from the shell. In tanks of over 5,000-barrel capacity, several openings are desirable through which temperatures may be taken, particularly where the oil is heated in storage.

12. *Time Element.* Temperature measurements are usually taken whenever gages are taken for accounting purposes to determine inventory on hand, product received, or product issued.

When making successive small issues from any tank, it is sufficient to take product temperatures each morning. In an underground tank, the product temperature changes take place slowly because of the combined mass of the tank and the earth fill around it, and there would be a prohibitive delay in taking product temperatures at the beginning and end of each small issue. This exception should not apply if the tank heaters have been operated during the day. If successive small issues are made from an aboveground tank, additional temperature

MIL-HDBK-201B
 23 September 1971

measurements should be taken only if, in the judgment of the gager, the rate of temperature change justifies them.

However, if a single issue over one-fourth but less than seven-eighths of a tankful is made, temperatures should be taken with both the opening and closing gages. Since wide temperature variations are normal in large non-working tanks of burner fuel, grade heavy, it is advisable to circulate this product in the tank before any temperatures are taken or any issues made. Considerable time is required for a thermometer to reach equilibrium in fuel oil. This time varies greatly with conditions; it seldom will be under 5 minutes, and may be 20 minutes, depending on whether the content of the tank is being heated or is at atmospheric temperature. The time necessary for a thermometer to reach equilibrium in diesel fuel oil or in gasoline is much less than the time required in fuel oil. When gasoline temperatures are taken, it is necessary to have thermometer cup full and to read the thermometer quickly before it is cooled by evaporation.

13. *Readings Averaged.* All temperature readings are averaged arithmetically to obtain the average oil temperature. The number of temperature measurements to be taken for shore tanks is a compromise between ideal accuracy and practicality, and is determined arbitrarily by the oil depth involved, as follows:

Depth of Oil	Number of Measurements	Where Taken
Less than 10 feet -	1	Middle of Oil.
10 feet but less than 15 feet	2	3 feet from bottom and 3 feet below oil surface.
15 feet but less than 20 feet.	3	3 feet from bottom, middle of the oil, and 3 feet below oil surface.
20 feet and over -	3	4 feet from bottom, middle of oil, and 5 feet below oil surface.

14. *Ship's Tanks.* The temperature of the oil in a ship's cargo tank is taken each time ullage gages are made for record purposes. They are taken at the mid-depth of the oil.

15. *Tank Cars and Tank Trucks.* In a tank car, one temperature is taken at the center of its contents; temperature is similarly taken in a tank truck when required.

16. *Gaging for Water.* The depth of water bottom obtained by taking a water cut, an operation usually accomplished by coating the plumb bob, or tape, with water-finding paste (chalk or litmus paper is an unsatisfactory substitute for the commercial paste). Resting the bob on the bottom for about 30 to 60 seconds is necessary to obtain the cut in a fuel tank. For tanks containing Navy special or grade heavy, the paste may need to be covered with lubricating oil. After withdrawing the bob, the fuel oil may have to be washed off gently with diesel fuel to reveal the water mark. In diesel fuel and lighter products, the cut is obtained more quickly. When it is necessary to measure the free water and sediment content of a tank car, such measurement shall be taken by coating the end of the gage stick with a light film of water-finding paste on the graduated face of the stick. The pole shall be lowered through the dome hatch to the car bottom and held in a vertical position until a cut is obtained on the paste. Precautions must be taken to see that the stick is not resting on a heater coil, rivet head, suction flange, or other projection on the tank bottom. The amount of water determined by taking water cut will be deducted from the total innage in a tank to determined product innage.

17. *Calculation Procedure.* When product is issued, the official quantity delivered should be determined from the shore tank gages, whenever possible. In the event of disagreement, shore tank figures govern. The ship's ullage gages, being subject to various uncontrollable inaccuracies, are used only when other methods are impracticable. When feasible, small issues shall be made from small tanks. If, for lack of such tanks, or for any other reason it is impossible to base issued quantities on shore gages, it may be agreed, by proper authority, to base the volumes on the bunker or barge gages. Simultaneous issues, if necessary, should be proportioned pro rate from the shore tank

MIL-HDBK-201B
23 September 1971

total by the use of the ship's gage where meters are not provided. For determination of quantities to be taken upon stock records upon receipt from ships, pipelines, and tank cars, see applicable department instructions.

18. Uncorrected Volume Determinations.

Tank gage tables are used to convert measured height of product to a corresponding volume of product.

19. Volume Corrections for Temperatures.

Since volume of product varies with changes in temperature a volume correction will normally be made on each individual bulk receipt of petroleum products of 3,500 gallons or over, except burner fuel oils, and on each individual bulk receipt of burner fuel oils, regardless of the quantity received. When this procedure is at variance with the provisions of existing contracts, volume corrections will be made in accordance with the contract. All corrections on fuel oils, diesel fuel oils, gasolines, jet fuels and other light fuels will be made to 60°F. in accordance with ASTM-D1250, table 7. This procedure is to be followed in all cases unless otherwise provided in individual contracts.

Example of Volume Correction to 60°F.

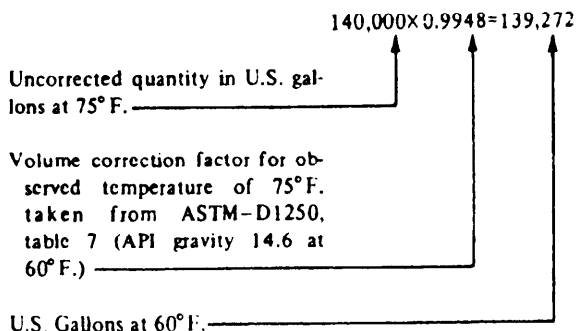

Conversion from Gallons to Barrels

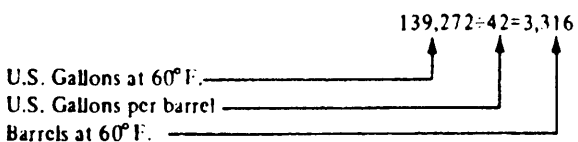

Corrections shall be made as follows: The weight of the roof shall be divided by the weight per unit volume (such as pounds per

gallon) of the product at 60°F. The resultant figure represents the volume in gallons, equivalent to the roof displacement, and shall be deducted from the gross quantity at 60°F. calculated for the gage opening or closing at which the roof was floating. The weight of the roof will be found marked on the calibration table.

- 20. Weight Conversion.** In many ports outside the United States, fuel oil is sold on a weight basis; in tons or other weight units. In arriving at the weight delivered, the specific gravity at 60°F. is generally used, but this temperature may vary in some areas. When quantity is computed on a weight basis, volume determinations computed in accordance with the illustration above will first be made and subsequently converted to the designated weight unit as in the following illustration:

Example of Weight Calculation Gallons to Pounds

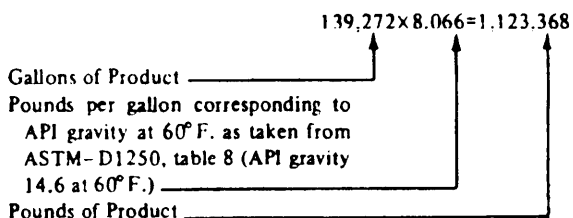

Conversion from Pounds to Long Tons

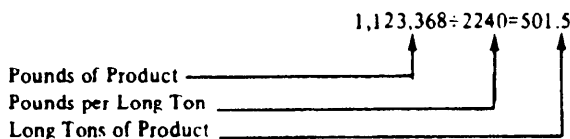

- 21. Records and Inventory.** It is necessary that records of measurements be maintained. Items such as methods of recording data, calculations to be made, forms to be used, distribution to be made, and the length of time records should be kept are outlined in applicable departmental directives.

b. Product Sampling.

- 1. Sampling Equipment.** Approved type sampling equipment should be used. This equipment may be of glass or metal and of a

MIL-HDBK-201B
23 September 1971

volume suitable for the sample desired. The tests obtained on a sample are of no value if the sample has been improperly taken, such as through improper sampling equipment.

2. *Type of Samples.* An average sample is one consisting of proportionate parts from all cross sections of the container.
 - A *Tube or Thief Sample* is one obtained with a sampling tube or special thief, either as a core sample or spot sample from a specified point in the container.
 - An *All-levels Sample* is one obtained by submerging the closed sampler to the bottom of the tank and then opening the container, such as by pulling out the cork and raising the sampler at a rate so as to be nearly full when reaching the top. These are rarely average samples because the operator cannot raise the sample at the rate required and also because the tank volume may not be proportional to the depth.
 - A *Single Tank Composite Sample* is one obtained by compositing equal portions taken from the upper, middle and lower thirds of the tank, the tank being an upright cylindrical tank.
 - An *Upper Sample* is taken from the middle of the upper third of the tank. Similarly, middle samples are taken from the middle of the tank and lower samples are taken from the middle of the lower third of the tank. A continuous sample is one obtained from a pipeline usually by means of a proportioning pump to obtain a representative sample of the material being shipped.
 - A *Bottom Sample* is one taken directly from the bottom of the tank or container. It is used to obtain water, scale, and other contaminants from the tank bottom.

The above are a few of the more common types of samples being used. The type of sample should be noted on the sample tag.
3. *Obtaining Samples.* Directions for sampling cannot be generalized to cover all cases. They must be supplemented by judgment, skill, and sampling experience, particularly

with regard to the type of sample to be taken. Extreme care and good judgment are necessary to obtain good samples. Samples must be kept in clean, dry, suitable containers. For example *Volatile Samples* (such as gasoline)—Transfer to a closed container and keep in a cool place at 30°F to 40°F if possible; *Light Sensitive Samples* (gasoline, jet fuel)—Transfer to brown glass or wrapped glass bottles or cans. (Coke bottles are never suitable sample containers.) To allow for product expansion and contraction, fill the sample container to not over an inch of the top. Before filling the sample container, it should be rinsed thoroughly with the product to be sampled. If the sample is being obtained from a tap or spigot, the connecting lines to the tap or spigot must be completely displaced by the product before obtaining the sample. Personnel trained in obtaining proper samples should take the sample.

4. *Labeling Samples.* Label the sample as soon as you obtain it. Use waterproof and oil-proof ink or a hard lead pencil which will scratch or dent the surface of the tag, thereby leaving a permanent legible marking. Always note at least the following information:
 - (a) Date and time sample was taken.
 - (b) Name of person taking sample.
 - (c) Name or number and owner of the vessel, car, or container.
 - (d) Nomenclature and grade of material.
 - (e) Type of sample.
 - (f) Sample number.
5. *Shipping Samples.* In cases where the testing laboratory is within the immediate area, samples should be taken to the laboratory as soon as possible. Samples shipped by freight or express must be packaged in required I.C.C. containers. Prior to shipping, prevent loss of liquid and vapors and protect against entrance of moisture and dust by covering glass stoppers with paper tied securely to the neck; also, screw caps should be tightened down snugly using a wrench.

MIL-HDBK-201B
23 September 1971

SECTION X. HYDRANT FUELING SYSTEM

4.34 GENERAL.

A hydrant fueling system is an underground or above ground storage-dispensing facility used for the safe, efficient handling of aviation gasolines and jet fuel at air bases. The systems are designed for use in issuing fuel directly into aircraft from outlets spaced within the parking apron, or occasionally, into refueler trucks at fillstands near the pumphouses. Operational control is at each fueling outlet or at the fillstand by an electrical switch and circuit or on demand by means of automatic flow and pressure switches. The hydrant system uses pumps to push the fuel through filter separators, underground pipelines, and control valves to the hydrant outlets installed in the apron pavement. A float control prevents overfilling of an underground tank with fuel. In many systems an electrically controlled valve permits the flow of fuel to the fueling outlets from the pumps when the circuit is actuated at the fueling point to start the pumps.

In newer systems connecting the pressurized hydrant system to the aircraft results in immediate flow. As the pressure in the system drops below predetermined settings, one or more pumps come on the line.

4.35 GENERAL EQUIPMENT AND FACILITIES.

- a. *Tanks.* The standard hydrant system operating storage tank is a 50,000 gallon, horizontal type, steel tank. It is 10'6" in diameter, 77'6" long, with flat heads. Because of fabrication inaccuracies, particularly where field assembled, each tank should have individual gage charts prepared for it, based on calibration after installation.
- b. *Turbine Type Pumps.* Installed in each tank is a 300 GPM or larger, electric motor drive, vertical turbine pump.

- c. *Water/Separators.* Installed just downstream from the pump beyond a basket type strainer and check valve is a 300 GPM or larger filter separator that automatically dumps any water removed from the fuel.
- d. *Fueling Control Valve.* The valve is solenoid controlled, hydraulically operated and is controlled by an electric switch at the hydrant fueling outlet. It is installed in a pit near the edge of the apron paving.
- e. *Defueling Control Valve.* Same as control valve except smaller size. It is in the same pit and is similarly controlled.
- f. *Defueling Pump.* A self-priming, horizontal, centrifugal pump, electric motor operated, controlled by same electric switch and circuit that controls the defueling valve, is also installed in the same pit.
- g. *Liquid Level Control Valve.* It is installed at the fueling outlet just below the coupler valve. This valve is required to keep the lateral pipe full of liquid (to keep vapor out) as the defueling operation is completed. It may be either float or hydraulic actuated.

4.36 OPERATION.

Delivery of fuel to aircraft is made by connecting a hose cart to the hydrant outlet in the airfield pavement and connecting the delivery hose to the aircraft. Pumps are started and stopped by means of electrical cables plugged into electrical outlets adjacent to the outlet. Care must be taken to be sure that hose cart and aircraft are properly grounded in accordance with instructions before starting fueling operations. Where pressure operated systems are installed, the system will be started by pressure drop on connection and stopped by aircraft shut-off valves.

CHAPTER 5. PIPELINES

SECTION I. INTRODUCTION

5.1 GENERAL.

Pipelines provide the most efficient means of moving petroleum overland. Although initial con-

struction costs of pipelines are relatively high, operating costs are relatively low. Thus, the longer a pipeline remains in use, the lower becomes the unit cost of moving petroleum. Pipelines are constructed and

MIL-HDBK-201B
23 September 1971

used by the military when the need arises to move large volumes of petroleum products over a particular area for an extended period of time. There are two general categories of military pipeline systems--intra-terminal and inter-terminal.

5.2 INTRA-TERMINAL PIPELINE SYSTEMS.

Intra-terminal pipeline systems are used within bulk terminals or depots to inter-connect storage tanks, tanker loading and unloading facilities, rail tank car and tank truck loading or unloading facilities, drum filling facilities, and in some cases a pumping station for an inter-terminal pipeline system. These systems permit receipt, storage, and issue of petroleum in bulk form. They are normally designed to be operated at pressures near 100 p.s.i. and are frequently called low pressure pipeline systems. Sec-

tions of pipe may be welded or coupled and may be emplaced above or below ground, although above ground installation is preferred for ease of maintenance.

5.3 INTER-TERMINAL PIPELINE SYSTEMS

Inter-terminal pipeline systems are used to connect two or more bulk terminals or depots. By means of these systems bulk petroleum products can be moved over long distances, and from port terminals inland. Sections of pipe are either welded and placed below ground for permanent installation, or coupled and laid on top of the ground as a temporary installation. These systems are designed to be operated at pressures up to 1000 p.s.i. or more for welded lines and 600 p.s.i. or more for coupled lines. They are often referred to as high pressure systems.

SECTION II. COMMON CHARACTERISTICS OF PIPELINE EQUIPMENT

5.4 GENERAL.

All pipeline systems consist essentially of piping, through which the bulk petroleum flows; pumps, which furnish the force to move the petroleum; and valves, by which the flow is controlled. The size, design, and capacity of each item of equipment is determined by the design and construction criteria for the system as a whole.

5.5 PRINCIPLES OF OPERATION AND MAINTENANCE.

Basic principles of pipeline operation and maintenance are generally common to all pipeline systems. Detailed operating and maintenance procedures must be developed for each system, taking into account its design, its mission, and the availability of personnel and spare parts for the equipment. Each military department is responsible for the preparation of detailed operating and maintenance procedures for pipeline systems for which it is responsible.

SECTION III. INTRA-TERMINAL PIPELINE SYSTEMS

5.6 GENERAL.

Since these systems are an integral part of bulk terminals or depots, detailed coverage of operations is

contained in Chapter 4, Section III and detailed coverage of maintenance is covered in Chapter 6, Section III.

SECTION IV. INTER-TERMINAL PIPELINE SYSTEMS

5.7 GENERAL.

Since inter-terminal pipelines are used to connect, and move bulk petroleum products between depots or terminals, it is essential that the terminals and pipelines be considered together as a single coordinated system. This principle applies to the planning

for such a system as well as its operation and maintenance.

5.8 PIPELINE COMMUNICATIONS.

Communications are normally by electrical means--telephone, teletype, and radio. Messenger communication by air, motor, and walking patrol is also used.

MIL-HDBK-201B
23 September 1971

5.9 OPERATIONAL CONTROL OF THE SYSTEM

In a military pipeline, the tanks, pumps, and tubing form a single closed system, usually containing several million gallons of fuel in process of transport. Operation of this system is handled as a unit under the direction of the chief pipeline dispatcher. The chief pipeline dispatcher is normally located at the base seaport terminal or pipeline headquarters. He exercises central control over the types, quantities, and destinations of all fuels pumped through the system. He controls the starting and stopping of all pumping operations. He is provided with continuous and exclusive communication with all pipeline installations and operating units. His functions include:

- a. *Scheduling.* Weekly and monthly schedules of fuel deliveries, based on the phased petroleum requirements.
- b. *Records.* The chief dispatcher receives and analyzes hourly reports from pumping stations, tank farms, dispensing stations, and other installations, of all fuel receipts, deliveries, and supplies in storage.

5.10 PROCEDURES FOR DELIVERY TO PIPELINES.

Before fuel is drawn from storage for delivery through the pipeline, it is first sampled and tested by laboratory personnel. Upon receiving clearance from the laboratory that the fuel contained in a particular storage tank meets specifications, the chief dispatcher may then schedule the tank for fuel delivery.

- a. *Single Product Delivery.* When quantity clearance is received by the chief dispatcher, he schedules a definite time for the start of a tender (batch) of fuel from a tank, or group of tanks, through the first pumping station.
- b. *Batching Two or More Products.* When two or more different types of fuel are to be handled successively in the same pipeline, the dispatcher must schedule the successive fuel tenders in the proper order, and he must provide information so that each pumping station and the delivery point know the time of arrival, amount, route, and destination of each tender.

1. *Batching Order.* Successive tenders of fuel should have approximately the same gravity. The size of "transmix", that is, the volume of contaminated fuel at the interface of successive tenders, is then at a minimum. The greater the difference in gravity, the greater the volume of the transmix. Water is not used to separate products because of the great difference in gravities between water and petroleum products. A fuel should be pumped preferably in front of or behind the next fuel in the following list: Aviation gasoline, motor gasoline, jet fuel, kerosene, diesel fuel, and distillate fuel oil. However, fuels can be run in any sequence.

2. *Dispatching Information.* The chief dispatcher controls the movement of all tenders from the starting point to the delivery point. He determines the location of the interfaces between tenders from velocity-of-flow and worksheets and informs all pipeline installations of the estimated time of arrival at each pumping station, tank farm, or other installation concerned. The information includes the type of product, color, gravity, and volume. The suggested order for transmission of dispatching information is as follows:

- (a) The type of product to be pumped.
- (b) Route and destination of the tender.
- (c) Volume of fuel in the tender.
- (d) The time the tender is scheduled to be started.
- (e) The time the head and tail of the tender is scheduled to arrive at each installation.
- (f) Identification data: color and gravity.
- (g) Disposition of mixed plugs.
- (h) Any other instructions required for mixed product operation.

5.11 PROCEDURES FOR RECEIVING FROM PIPELINES.

When notification is received that pipeline shipment has been scheduled, the supervisor in charge of the receiving terminal checks the receiving tanks to see that there is sufficient room for the tender and that the tanks are clean. He notifies the dispatcher if, for any reason, delivery must be deferred.

MIL-HDBK-201B
23 September 1971

Interfaces are identified as they pass each intermediate station by gravity and color checks. Dispatcher is notified by teletype of time of passage and all other pertinent data. On arrival, the new tender is switched to the appropriate direction by simultaneously closing the valve on the former grade of fuel and opening the valve of flow for the new tender.

Dispatcher will notify receiving terminal of disposition of the interfacial mixture into slop tanks or into storage where minimum effect on fuel properties is incurred.

5.12 OPERATING REPORTS.

The entire fluid content of the pipeline system is accounted for hourly by telephone and teletype reports from tank gagers who measure the fluid content of each tank in the system.

5.13 FLOW MANAGEMENT.

- a. *General.* Fuel flow between tanks, pumps, and pipelines is controlled by block valves located at appropriate points. To be able to direct flow where it is desired, station personnel must be thoroughly familiar with the layout of all pipe, manifolds, and valves at their stations.
- b. *Identification of Lines and Valves.* Each pipeline should be numbered, and it should carry the same number throughout its length. Each station should be constructed according to a standard layout. All connections, gate valves, manifolds, pumps, tanks, and associated installations should be numbered. One copy of the station layout plan, complete with component numbers, should be kept by the chief dispatcher, and one copy should be kept at the station. Pipelines should be color coded according to MIL-STD-161, Identification Method for Bulk Petroleum Product Systems. This standard is mandatory for use by the Military Departments.

5.14 PIPELINE PATROLS.

The main purpose of patrols is to detect actual or potential leaks and breaks in the line; secondarily,

patrols serve to discourage sabotage and pilferage. Patrol schedules are irregular, so that saboteurs and thieves cannot count on free time for their purposes. Breaks in the line or major leaks, are usually detected fairly quickly by pump station operators from suction and discharge pressure readings, or more quickly, from the change in the normal sound of pump engines. Station operators should investigate immediately any unexpected or unfamiliar sounds. Minor leaks, and the points where leaks or breaks are likely to develop, are detected by oil seepage or dead vegetation and reported by pipeline patrols. Methods of pipeline patrol include walking, motor vehicle, and airplane.

5.15 PIPELINE MAINTENANCE.

Proper patrolling of pipelines often discloses potential danger points before serious damage occurs, and prompt maintenance prevents serious breaks and losses of fuel. Patrols and repair crews must be alert to critical crossings and areas where line damage may be expected.

5.16 PIPELINE REPAIRS.

Major repairs too large or complex for operational personnel are usually performed by specialized maintenance crews under the direction of maintenance supervision.

5.17 PIPELINE CLEANING.

Foreign materials accumulated during construction, repair, or operation may block the line and cause considerable trouble and reduced efficiency of pumping. In addition, over a period of time the inside surface of the pipe becomes roughened with corrosion, increasing friction loss and decreasing pipeline capacity. Pigs or scrapers are utilized to clean the interior of pipelines and are generally scheduled to be run through the pipeline at periodic intervals or on an "as needed" basis.

MIL-HDBK-201B
23 September 1971

CHAPTER 6. TANK FARM OPERATIONAL MAINTENANCE

SECTION I. INTRODUCTION

6.1 GENERAL.

This part covers maintenance normally performed by skilled operational personnel such as pump operators, enginemen, electricians, and machinists under the control of the fuel depot supervisor. This work may include inspection, servicing, valve and pump dismantling and repacking, external adjustment and repair of prime movers. Major repairs such as structural maintenance, machining of valve and pump parts, rewinding of electric motors, dismantling and overhaul of prime movers and pipeline installations or alterations are the responsibility of maintenance forces. These forces may or may not be assigned as part of the fuel depot organization. The applicable technical publications should be consulted for technical guidance affecting maintenance. In addition, maintenance records, documents and schedules as prescribed in service publications will be maintained.

- a. *General Care of Facilities and Safety of Personnel.* All facilities comprising a military fuel depot must be maintained in first-class condition. Good housekeeping and constant attention to mechanical details are essential to proper maintenance. The premises, buildings, loading platforms, fire stations, pumphouses, dikes and piers must be kept free of debris and surplus equipment and materials.
- b. *Equipment Records.* The supervisor should obtain all pertinent information regarding the facilities provided, including detail piping layout, general pipeline maps, utility and signal diagrams, manufacturer's equipment specifications and operating instructions. This information should include the design data, perform-

ance curves, and spare parts lists for each kind of pump. The maintenance program should be coordinated with the corrosion control and conservation programs. A well kept set of leak records is a necessity. Records should include the type, cause, and location of each leak as well as the type and cost of repairs. From these records, corrosion control and conservation can be facilitated.

- c. *Equipment Operations.* Except where deviations may be allowed as the result of sound and demonstrated reasons, the supervisor should see that all pumps and other apparatus are operated in accordance with the operating instructions included in the appropriate Military Technical Manuals or manufacturer's equipment manuals. Units must be kept clean, properly lubricated and adjusted. A log or card record may be kept showing actual use of major pieces of equipment.
- d. *General Safety Rules.* Both in the operation of the depot, and the maintenance of machinery, established safety rules should be followed to guard against injuries to personnel and damage to equipment. These rules include the posting of necessary warning signs, the use of protective equipment when necessary, the provision of proper ventilation, lighting, tools, scaffolds, ladders, etc. Only qualified personnel should be allowed to enter pits, tanks, buildings, or enclosures where fire, explosion, asphyxiation, and similar hazards may be encountered. Well informed, diligent, and alert personnel are most conducive to efficient and safe operations.

SECTION II. FACILITY INSPECTION

6.2 GENERAL.

- a. *Inspection Responsibilities.* It is the responsibility of the supervisor to establish an inspection program, with emphasis placed on safe

operating and maintenance procedures. This inspection program should include an inspection of facilities during operation; periodic inspections; and special inspections, as for example, inspection of fire-fighting facilities.

MIL-HDBK-201B
23 September 1971

The supervisor should review carefully each inspection report and take remedial and corrective action as necessary. A thorough and careful visual inspection to include tank exteriors and appurtenances, valves, pipelines and pumps should be made at least monthly to determine the need for maintenance and repairs. Tank interiors should be inspected as prescribed by MIL-STD-457. In addition to regular scheduled inspections, supervisors should be inspection conscious in their regular duties to the extent that they are always on the alert to note deficiencies, impending breakdowns, and any improper conditions or procedures. Frequent consultations with working forces are a most valuable source of information regarding performance, timely repair and improvements.

- b. *Inspections Prior to Use.* New construction and facilities that have been on standby basis should be inspected prior to acceptance of reactivation, to assure that they will meet requirements and function as intended when placed in operation. The officer in charge or the supervisor and his staff should make a complete visual inspection of the facilities both from physical and operational viewpoint with special attention being given to safety, fire prevention, and fire protection features. The facilities provided at various military activities differ to such an extent that no detailed check list for initial inspections can be included in this handbook. Many of the common points to be noted are:
1. *Security.* That proper provisions have been made against admittance of unauthorized persons and the proposed security provisions do not unduly restrict the access or movement of the operating personnel, particularly in an emergency.
 2. *Communications.* That the communications facilities provided are conveniently located. That these facilities are so arranged that they are free from interruptions during the transmission of emergency orders during operations.
 3. *Tanks.* That all tanks have been tested for leaks, cleaned, and equipped with proper accessories.
 4. *Access Facilities.* That access facilities for operators, such as stairways, ladders, and platforms are provided, and are in the right locations and properly guarded with handrails. That long ladders are provided with back guards and offset platforms. That entrance hatches are guarded or gated. That stairways are provided at points where frequent or rapid entrance is required or where operators must carry sampling equipment and tools.
 5. *Emergency Shutoffs.* That in case of accident the flow of oil can be readily shut off from a distance by means of properly located valves. That the electric power may be cut from individual units without affecting the entire area.
 6. *Piping.* That the entire piping system has been tested hydrostatically to 1½ times the allowable working pressure (not less than 100 p.s.i.). That the piping is properly supported, adequately anchored, and has enough flexibility to prevent overstrain of the connection to the attached equipment. That there are sufficient drains and sample cocks. That there are sufficient pressure relief valves installed around block valves for the relief of excessive pressures due to thermal expansion of the product.
 7. *Large Valves.* That large valves to be operated under pressure are provided with reduction gears.
 8. *Cast-iron Valves.* That cast-iron valves, originally installed in place of steel valves at critical locations such as at tanks or piers, should be replaced with steel valves when possible without interfering with the depot operation. That sufficient steel valves are available for replacement.
 9. *Bonding and Grounding.* That proper bonding and ground protection is provided.
 10. *Identification.* That pumps, valves, and lines have been painted and stenciled for identification, and that buried pipelines or cables are marked by ground markers or offsets to surface reference points. (See MIL-STD-161.)

MIL-HDBK-201B
23 September 1971

11. *Pressure Gages and Thermometers.* That the piping has been equipped with an adequate number of pressure-gage connections at critical valve locations in the pump-house, oil pier loading connections, heaters, and tanks. That thermometer wells are placed at heater inlets and outlets (outside of tanks). That thermometers and pressure gages of suitable quality, size, and range have been installed and tested and are protected against vibration and surge damage.
 12. *Machinery Guards.* That exposed moving parts of machinery are guarded to prevent injury to personnel.
 13. *Tools and Equipment.* That necessary tools and auxiliary equipment have been provided, and that lockers are available for their storage.
 14. *Ventilation.* That all buildings, especially pumphouse or pits, are dry, clean, and properly ventilated.
 15. *Drains.* That floors in areas where oil spills may occur are sloped to a properly trapped drain. That sump pumps are installed properly, where necessary.
 16. *Lighting.* That illumination is adequate, for convenience and safety and that the fixtures are of the correct type and are properly installed.
 17. *Ground and Drainage.* That grounds are adequately graded and drained. That dikes surrounding tanks are to proper grade and in good condition.
 18. *Signs.* That "NO SMOKING" and other warning signs have been posted, and other necessary warnings signs are at hand ready for use.
 19. *Pier Safety.* That piers are equipped with emergency ladders, life preservers, small boat, and first-aid equipment.
 20. *Fire Protection.* That adequate fire-fighting equipment and supplies are available and that first-aid fire equipment is charged and properly located.
- c. *Operational Inspections.* Prior to starting a major operation, pumps, couplings, and primemovers should be tested and inspected to insure proper performance and eliminate breakdowns that might cause costly delay during the transfers of products. Lines should be walked and checked for leaks; hoses should be visually inspected and only hose showing successful testing within the prescribed period should be used. All other facilities to be used in an operation, but not herein specifically mentioned, should be checked to make certain they are in satisfactory condition. During operations, operating and maintenance personnel should remain alert to observe performance and to note any defects in the machinery. Undue vibrations, overheating, and improper working pressures should be reported and investigated. Careful observations and prompt reporting may often prevent serious damage and costly repairs.
- d. *Periodic Tests and Inspections.*
1. When extensive changes or repairs have been made, a local inspection should be ordered and a detailed report prepared, showing the general condition of the tanks, piers, pumps, boilers, oil and steam lines, power facilities and communication systems, heaters, filters, buildings, boundary fences, roadway drainage ditches, and water-supply systems including wells, intakes and reservoirs.
 2. *Freezing Weather Precautions.* A special inspection should be made early in the autumn of each year in climates where freezing weather is encountered to assure all drains are functioning and that necessary precautions are taken so that steam lines, pump bleeders, heater drains, other small drains, traps, radiators, water jackets, small pipelines, pumps, and valves are not damaged by freezing.
 3. *Tank Accessories.* Regular inspection should be made of the apparent condition of all tankage and tank accessories; including pressure and vacuum relief valves, flame arrestors, and vent screens, exhaust fans, cargo and sump pumps, motors and their protective devices.
 4. *Pier Facilities.* Regular inspection of the piers should be made to assure that they are in good condition, free from surplus material, and that deck openings are closed. That

MIL-HDBK-201B
23 September 1971

facilities such as lines, valves, and electrical bonding equipment are in good condition and protected from external damage. That at least one suitable small boat is available and accessible for emergency use, and that a sufficient number of ring buoy life preservers with lines attached are provided and placed at their proper locations.

5. *Cargo Hose.* The inspection should determine that the cargo hose is the type and size best suited for the kind of product handled. That it is provided with a built-in grounding conductor if required and is stored on a weather protected hose rack when not in use.
6. *Bonding.* All pier lines should be checked to determine if they are properly bonded to a ground connection sunk below the pier at a point near the unloading connections, and also at the shore line if the pier approach is of considerable length. If protection from stray electrical currents is required, insulated pipe joints should be provided at or near the shore.
7. *Pumps and Compressors.* Pumps and compressors will be periodically inspected for alignment, wear, packing, seating of valves, lubrication, etc. In making the periodic inspections, particular attention should be given to the following items:
 - (a) *Performance Test.* Pumps should be thoroughly inspected whenever their actual performance compared to the designed performance or the initial performance during tests indicates that capacity and pressure have fallen off. This should also be done when the performance of any of several identical pumps in the same service is below the normal performance of the others.
 - (b) *Operation Test.* Acceptance tests on pumps should be run and their performance checked against the specifications under which they were purchased. Preliminary operation tests should be conducted with the product to be handled at the optimum pumping temperature to establish a basic rate or performance for

checking the future condition and future operation of the pump.

- (c) *Stand-by Operation.* Except when the tank is empty, or if a bypass valve directly from the pump to the tank has not been provided, pumps installed at individual storage tanks not in normal use should be tested each week by running the pumps for a designated period of time allowing the product to circulate back into the tank. If the tanks are empty or bypass valves have not been provided the pumps should be turned over by hand.

8. *Electrical Equipment.* The chief electrician should be instructed to make period inspections in addition to casual checks during routine operations to assure that all electrical motors are kept clean and properly lubricated, and that all bearings are properly adjusted. Transformer stations and all feeder and distribution panels should receive routine inspection and service. Periodic inspections should also include communication systems and other electrical equipment. After alterations or additions have been made to an electrical installation the map and diagrammatic sketches of the electrical layout should be verified jointly by the supervisor and the electrician as a means of familiarizing the supervisor with any revision recently made. Spare cable and fittings should also be checked as to their proper storage location and condition so that it can be made ready for emergency use on short notice. Cathodic protection of tanks and lines should be tested quarterly by specially trained and qualified personnel to assure that actual protection of the tanks and pipelines against corrosion is provided as planned.
9. *Oil Heater Pressure Test.* When a fuel oil heater has been repaired, the oil side (if of shell and tube type) should be subjected to an oil pressure test to $1\frac{1}{2}$ times the normal allowable operating pressure. The steam side should be given a hydraulic test at a pressure equal to $1\frac{1}{2}$ times the allowable working pressure. During regular inspection heaters should be tested at $1\frac{1}{2}$ times the

MIL-HDBK-201B
23 September 1971

allowable working pressure; and in making this test air must be vented from heater before the pressures are applied. All pressure tests of the oil heater and piping should be made with the hand fuel pump. When oil heaters are in use, the flow of oil should be at the rated capacity. Under such conditions, if the pressure drop is considerably higher than was found to be the case during acceptance tests, or if the oil temperature rise is not in accord with expected results, the heater should be dismantled, inspected, and cleaned if necessary. When heaters are dismantled for cleaning they should be inspected for any indications of corrosion and a record made of the finding for future reference. This is to determine whether or not corrective measures to retard corrosion are effective. It is impossible to set any fixed intervals for heater inspections as the interval will be determined largely by the use of the heater and the nature of the fuel. If corrosion is noted when cleaning, a heater should be inspected thereafter at intervals not to exceed 6 months until it has been definitely established that the corrosion has been checked. Otherwise, heaters will not usually be opened up as long as they are tight when pressure tested and perform satisfactorily.

10. *Pipeline Inspections and Tests.* Pipelines in a military depot should be tested for leaks periodically. This may be done while the lines remain filled with the same product used in normal operations providing all the air is eliminated from the section selected for testing. The test pressure is to be $1\frac{1}{2}$ times the normal operating pressure but at not less than 100 pounds per square inch. In conducting this test a 10 percent drop in pressure will be allowed for the first 2 hours, after the valves have been closed and pressure established. If the pressure drop in this time exceeds 10 percent, then a leak is probably indicated. The leak must be located and repaired immediately. After repairs have been completed, the test must be repeated until satisfactory results are obtained. These tests should be recorded and covered by report.
11. *Steam Plants.* Boiler or steam plants operated exclusively for military fuel-storage depots are the responsibility of the boiler-house operator. Hydrostatic tests and inspection of furnace walls, baffles, insulation and roof blocks of the boilers proper, as well as inspection of feed-water heater, feed pumps, and all accessories should follow the general military requirements for such services at military installations.
12. *Strainers, Filters, and Meters.* Strainers and filters, water separators, air eliminators, and metering equipment of all kinds should be inspected according to established procedures.
13. *Pressure Gages and Thermometers.* All temperature and pressure gages should be periodically examined and checked for accuracy. If they are used frequently, the inspection should be made any time there is reason to question the accuracy of an instrument.
14. *Buildings.* Buildings should be checked for alinement and the physical condition of the foundation, also in regards to general condition, and particularly as to fire hazards. The exterior should be checked for condition of gutters, downspouts, paint, roof, chimney, and general appearance.
15. *Tank Car and Tank Truck Racks.* The supervisor or his assistant should check the railroad siding to determine that all rail connections are properly bolted, rails spiked, bumper securely fastened, ties well tamped, and that the track is level along the loading and unloading stations. The pipelines at the stations should be inspected to make certain they are covered with earth or otherwise protected from possible physical injury. The supervisor and operator should also see that rail bonds and grounding wires, as well as the insulated joints, where required, are properly installed. They should see that the drip tubs, tools, and flag stop signs are on hand. The hoses and connections should be inspected to assure they are in good condition and are supplied with built-in grounding conductors where required. Bonding facilities

MIL-HDBK-201B
23 September 1971

at tank truck loading racks should be particularly checked. The trap or screen in the line from the unloading connection to the storage tanks should also be inspected, and cleaned when necessary. Tank car and tank truck rack structures, walkways, and ladders, at loading stations should be kept in good condition, and loading arms, swing-joints, piping, and valves should be kept free of leaks.

16. *Fences.* Boundary fences, where provided, should be inspected for condition and alignment of posts, for loose or broken wire, and for conformity of the bottom of the fence with the ground.
 17. *Roadways.* Inspectors of roadways within the depot and on its approaches should include the condition of the grade, drainage, surface, and need for additional surfacing. On concrete roads, the conditions with respect to subdrainage, holes, cracks, unevenness, and erosion of earth along the edges should be noted.
 18. *Railroad Tracks.* Railroad tracks within the depot area should be checked for alignment, elevation, drainage, surfacing, condition of ties, tie spacing, loose spikes, and rail joints, worn rails, derails, worn and loose switches and frogs, and the condition of trestles, and culverts. While making the inspections, the purpose for which the equipment is used should be borne in mind. For example, a track used as a siding only might be reported adequate although it had defects which would be corrected if such defects were found on a main line or service track.
- e. *Fire Protection Facilities.* At a military installation the fire chief is responsible for all its fire-fighting facilities, their testing, maintenance,

and operation. The fire chief will periodically furnish his superior and the supervisor of the military depot with reports on the conditions of these facilities. Fire pumps, lines, and equipment which have not been in use should be tested at intervals specified by the district fire protection engineer, the department chief, or district fire marshal. It is good practice to hold fire drills in different locations each month at about the time the fire pump and auxiliary equipment are to be tested. All regular depot operating personnel should be informed and drilled under various assumed emergency fire conditions, to quickly locate the proper valves to be closed and the equipment to be shut down in case of emergency in order to minimize the spread of fire.

1. *Fire Pumps.* The fire pumps should be checked for pumping capacity and pressure at intervals designated by the Chief of the fire department. For specific instructions see list of publications.
2. *Couplings.* Couplings on fire hose at a depot should be checked to see that they are interchangeable and will fit all fire hydrants. Should the hose coupling threads used in neighboring municipalities or industries be different, suitable adapters should be readily accessible for use in case neighboring facilities are called in case of emergency.
3. *Hose.* Reserve stocks of stored hose should be kept in a dry cool place where they are not exposed to the rays of the sun. Fire hose should be inspected and tested in accordance with existing regulations. Inspection of stationary fire facilities attached to storage tanks should be made in accordance with rules prescribed for each terminal or fueling depot respectively.

SECTION III. TANK FARM MAINTENANCE

6.3 GENERAL.

This section outlines the broad requirements involved in the maintenance of the tank farm.

6.4 MAINTENANCE SCHEDULES.

Maintenance schedules, as prescribed by Military Service Publications, should be prepared to minimize

MIL-HDBK-201B
23 September 1971

the possibility of equipment failure. For maximum effectiveness, schedules should be geared to local operational procedures in order to provide for full utilization of available personnel during slack operational periods. Past operational data and anticipated maintenance requirements will prove useful in the development of such schedules.

a. *Machinery History (Equipment Maintenance).*

Records should be established for major pieces of equipment. These records will show repair data and will also serve as a guide for future maintenance planning. The equipment manual, which includes information in regard to the facilities provided at an oil depot, such as maps, specifications and manufacturers' operating instructions, etc., is one of the most important records to be secured and kept by the superintendent. It is suggested that as a maintenance record, each important unit requiring periodic inspection, maintenance, and tests, be listed in a card file, or loose-leaf binder. A simple form that will show in chronological order pertinent information in regard to inspections, tests, adjustments, repairs, or replacement parts, should suffice. These cards should be prepared not only for pumps, valves, compressors, engines, and motors, but should also include cargo hoses, tanks, meters, heaters, filters/separators and other equipment pertinent to plant operation. If the card system is too elaborate, it may become burdensome; if it is simple and accurately kept, it will be of great value. To insure that inspections are made when due, the superintendent may supplement this card file with a tickler or calendar file which should be referred to regularly at some designated time.

- b. *Periodic Overhaul and Inspection.* Machinery and equipment should be disassembled for inspection and overhaul after use periods based on either passage of time or gallonage handled or operating hours. For establishment of use periods, the maintenance forces should be guided by technical publications and bulletins of the service concerned and manufacturers' maintenance guides.

6.5 TANK MAINTENANCE.

- a. *Tank Grades.* Gravel or equivalent aggregate bases or tank grades should be so maintained

that the bottom of the tank is higher than the general grade of the adjacent natural or established ground level. The tank bottom will be found to be about 12 inches higher than the ground level especially in locations subject to heavy rains, or frozen surfaces or soil having high runoff. The grade surface should be sloped gradually downward, away from the elevation of the edge of the bottom sheet, to meet the yard or tank farm grade; the shoulders thus formed should be surfaced with crushed rock or similar material, penetrated with asphalt if available. This will allow adequate drainage of surface water away from the tank bottoms to the drainage ditch system and will reduce erosion of tank bases, and corrosion of underside of tank bottoms.

Shoulders bordering bases should be graded to leave protruding edge of tank bottom sheet or bottom angle if there is one, visible at all times, with no low spots to allow collection of water against steel. When bases show settlement away from tank bottoms, material should be added and well packed under the tank bottoms. Steps should be taken to fill these voids immediately, thus preventing further undermining of the bottom of the tank. Some of the older tanks at military bases may be found to rest on concrete slabs, provided usually to distribute the loading more evenly, having a curb extending upward several inches above the tank bottom elevation. This curb, in many cases, admits and retains water between the tank and the curb, causing the tank bottoms to rust. In such cases the curbing should be removed or drainage shots cut into the curb to permit release of water, and the steel that was behind the removed portion should be painted. Where curb is close to the tank shell, and is allowed to remain, the space between the curb and the tank shell should be filled with asphalt or other suitable material or properly calked.

- b. *Tank Painting.* Painting of tanks at intervals dictated by local conditions is necessary and important for general appearances, the preservation of steel, and for the reduction of evaporation losses where light colors are permitted by camouflage regulations. Portions of the shell and bottom, particularly near their juncture, should be examined for evidence of excessive corrosion. Tanks should be painted in accord-

MIL-HDBK-201B
23 September 1971

ance with standard applicable military color specifications. Tank tops, particularly where the tanks are used for storage of volatile products should be painted preferably in a very light color to help reduce losses due to evaporation. It is sometimes necessary to use special corrosive-preventive paints on bottom juncture, especially where exposed to excessive dampness and salty atmospheres.

Interior coating guide lines for tanks at military installations are cited in DoD Technical Manual entitled "Interior Coating Systems for Surfaces in Contact with Petroleum Fuels".

c. *Water Bottoms.* Tanks in military establishments should not carry a water bottom. However, if a tank bottom is known to leak, or is suspected of leaking, a water bottom should be used only for as long a time as necessary to remove the tank product on an emergency basis and make the required inspection. Repairs to tank bottoms should, of course, be made as soon as conveniently possible.

d. *Tank Roof Leaks.* When tanks are cleaned, for repair or for other reasons, the entire interior should be inspected. In vertical tanks this includes the roof structure, the underside of the roof, the internal valves or swing lines, and swing line cables as well as the tank shell and bottom plates. If the roof of a tank leaks it should be sealed. Large leaks in the roof of a steel tank should be calked by first inserting oakum or wick packing before applying the calking compound. Some riveted tanks may not be tight at the junction of the roof and shell. Where such tanks are in volatile product service, and it is impossible to stop the vapor leak, the tanks should be taken out of such service. If the roof of a gasoline or jet fuel tank is suspected of leaking, it may be tested by applying soap-suds to the seams or joints at a time when the pressure inside the tank is building up due to thermal expansion or when product is pumped into the tank.

e. *Tank Ladders and Stairways.* If tank stairways, handrails, platforms or catwalks are unsafe, they should be repaired or strengthened immediately. When practicable, ladders in a perpendicular position should be changed to slope not less than 2 feet horizontally to 12 feet verti-

cally. Ladders that have excessive sway should be adequately braced.

f. *Tank Grounding.* Tanks mounted on concrete saddles above grade should be grounded by means of a driven ground rod and ground wire connected to the tank shell by brazing. Above ground storage tanks in direct contact with the ground need not be grounded.

g. *Concrete Tanks.* Inspect the base and roof seals in concrete tanks for leaks. Never permit product to touch the underside of the roof.

h. *Tank Linings.* Care should be exercised in entering a lined tank to avoid damage to the lining.

6.6 TANK FITTINGS.

Tanks not equipped with a floating roof, assigned to gasoline and jet fuel service are normally erected with pressure-vacuum type vents, while other storage tanks in fuel oil service will be supplied with free vents.

a. *Vents.* The vents on tanks having a working pressure exceeding 2 p.s.i. will require frequent attention and should be checked only by personnel who are familiar with the operation of pressure-vacuum vents operating under high pressure. In case the vents are provided with screens, the screens should be cleaned or replaced at the first sign of corrosion or clogging. For safe operation it is necessary that the moving parts work smoothly. To insure continued smooth operation, where stem-type pallets are used, the stems may be cleaned with kerosene. If the parts cannot be readily cleaned by the above methods, a mild liquid metal polish will be found effective, but all the compound should be removed from the cleaned parts before placing them back in service. The pressure and vacuum vents as illustrated in figure 2 represent the types normally used at military oil storage activities however, any other type will consist basically of the same moving parts and therefore will be subject to the same cleaning methods. It is very important that the weight of the pallets be adjusted to permit tank vents to operate within the pressures recommended for the tanks on which they are installed.

MIL-HDBK-201B
23 September 1971

- b. *Flame Arrestors.* If flame arrestors have been provided, the banks or elements are generally made of corrugated metal sheets. They should be kept free of dirt, rust, and loose deposits or other foreign matter. While cleaning the flame arrestor, if any loose matter is lodged between the corrugated sheets, the bank should be blown out with dry compressed air; the inspection cover should then be closed and firmly tightened. Remove flame arrestor elements when temperature is extremely low and there is danger of condensate freezing. It is necessary for the operating personnel to be fully informed and become familiar with the operation of vacuum vents and flame arrestors, paying particular attention to cold weather precautions.
- c. *Pressure and Vacuum Vent Valve Settings.* Small vertical tanks not over 10½ to 11 feet in diameter can be operated at 1-pound pressure if in good condition. Large vertical cone roof tanks are usually operated at pressures not exceeding ½ ounce. Pressure and vacuum vent valves on cone roof type vertical tanks and small horizontal tanks are usually set to relieve at ½ ounce pressure or vacuum. In addition to the atmospheric type tanks there are also pressure tanks such as spheroid, hemispheroid, etc., which are operated at pressures up to 2½ p.s.i. with vacuum settings up to 2 ounces. Regardless of the type of tank, the Military Technical Manuals/Manufacturer's Specifications should be checked to determine the safe operating pressures, and if this information is not available, it should be obtained from the responsible Military Service. It is recommended that maximum pressure and vacuum settings of ½ ounce be established until such time as definite information regarding the tank in question can be secured. It is important that the vents be adequate in size, or excessive pressure due to fast filling rates may cause damage to the tank roof. It is equally important that the vacuum side of a pressure and vacuum vent is operating properly, and of adequate size, in order to prevent collapse of a tank during issue of product from the tank.
- d. *Gage Hatch Covers.* Gage hatch covers on gasoline tanks shall be kept vapor tight except when entrance is needed. As the weight of the cover alone becomes too cumbersome for tanks operating at over ½ ounce vapor pressure, some gage covers at the various fuel depots are equipped with thumbscrews or wing nuts to permit keeping covers fastened tightly when tanks are not being gaged. If the threads on the bolt are stripped or painted over, or for some other reason cannot be properly tightened, the defect should be remedied. When securely fastened, if the cover cannot be made vapor tight, it should be replaced. This type of cover can be provided with means for locking if required and if so ordered. Some gage hatches are equipped with spring hinge and gasket. If the spring is not working properly and does not keep the cover tight, it should be replaced. There are other hatch covers, equipped with gaskets only, which should be checked to make sure that the gasket is providing a proper seal, and if not, the gasket should be promptly replaced. If volatile fuel tanks are equipped with gaskets only, they should be checked to make sure that the gasket is providing a proper seal, and if not, the gasket should be promptly replaced. If volatile fuel tanks are equipped with gage hatches and covers, consisting of a standard pipe nipple with screwed cap, they should be replaced with satisfactory approved gage hatch. It has been found that screwed caps are rarely if ever kept tight. Gage hatches on volatile fuel tanks that can neither be kept vapor tight nor repaired to be kept vapor tight, especially those that do not have a beveled edge or gasket, should also be promptly replaced.
- e. *Foam Chamber.* If foam chamber connections are not vapor tight, they should be made tight. Open foam chamber and inspect diaphragm. If cracked or broken, it should be replaced.
- f. *Swing Line Assemblies.* If the use of a swing line assembly has been discontinued, the mechanism at the top of the tanks should be removed. Any openings, due to this removal, should be permanently sealed so that no vapors can escape.
- g. *Automatic Gages.* Automatic ground level reading tank gages should be maintained in accordance with manufacturer's instructions. Connections to tank should be kept vapor tight, especially when in use on tanks storing gasoline, jet fuels, and similar products. Gages should be properly adjusted by making automatic reading

MIL-HDBK-201B
23 September 1971

agree with the average of several hand gages taken under ideal conditions. After original setting, the automatic readings should be checked against hand readings at regular intervals to make sure that they are in agreement. If the M-type gage is regularly used, the oil seal should be maintained. M-type gages which are not in use should be removed and all openings, caused by this removal permanently sealed.

- h. *Valves.* Cast iron or semisteel brass mounted tank valves should be replaced with steel valves when the tank can be conveniently emptied.
- i. *Draw-off Valves.* Leaking water draw-off valves should be replaced when tank storage levels and operating conditions safely permit. Brass and brass mounted water draw-off valves should be protected from exposure to ground spill fires, breakage, and freezing. They should not be blanked off.

6.7 CONSERVATION TYPE STORAGE TANKS.

There are several types of conservation type storage tanks found at military installations. Most common are the floating roof, and cone roof with internal floating pan tanks.

- a. *Conventional Floating Roof Tanks.* Floating roof tanks and the principles are described in Chapter 4. The success of a floating roof tank depends largely on the seal between the floating roof and the shell. If the roof is not absolutely level or is sticking, necessary repairs should be made.
 - 1. *Weather Precautions.* Maintenance of floating roof tanks except for the usual painting and inspection is practically negligible when the temperature is above freezing. The collection and disposal of rain and snow on the floating roof presents some difficulties which can be troublesome in areas subject to very low temperatures or heavy snowfall. During the summer months these roofs require only routine attention because rain water is drained from the roof through a flexible drain line or allowed to pass through the product and drained from the tank bottom. Where water is allowed to pass through the product by means of an open drain, ample time must be allowed for the water to settle out of the product, and then it must be drained from the tank bottom at

regular specified intervals, and especially before the tank is opened for issue. Where long periods of extreme cold are not usually encountered, some tank farm operators allow snow and ice to collect on the floating roofs. During periods of thaw, the collected water must be drained off. Where long periods of extreme cold are encountered causing the temperature of the product in the tank to drop below 32°F, some tank farm operators avoid draining water from the tank roof during the winter months by closing off the regular roof drain. Unless the regular roof drain is watertight water may accumulate in the draw off line and when the temperature of the product in the tank drops below 32°F, the accumulated water will freeze and rupture the drain line. Where water drains directly through the product, ice accumulation may form on the tank bottom in the form of inverted icicles. In order to avoid excessive ice accumulation on the roof, when the regular roof drain is maintained in a closed position, it is sometimes advisable to pump or siphon water over the tank shell before it forms into ice. In any case, the emergency drains must remain open and operable to relieve excessive water loads due to unpredicted heavy rainfall. The water draw off valve at the lower end of the flexible water draw off line should not be blanked or otherwise plugged, but remain in operating condition and periodically opened to guard against water accumulations in the line. Snow should be removed from the roof promptly after each storm. As snow removal is further complicated if the tank is only partially filled, it is advisable to pump from one tank to another to raise the floating roof to its highest position, thus facilitating snow removal. In northern climates, it is essential to have sufficient personnel available to dispose of a heavy snow load. Where it is not practicable to completely remove snow from the roof promptly after a storm, drifted snow must be levelled because of the possibility of tilting the roof. Any accumulation of snow, ice or water on a floating roof must be taken into account when gaging the tank. During long freezing spells check at frequent intervals to insure that roof seals are not

MIL-HDBK-201B
23 September 1971

frozen to the tank shell. Roof must not be hung (not floating on product) when there is any possibility of snow or ice accumulating on the roof unless adequate shoring is provided to prevent collapse of the roof structure because of the imposed load. Consult the installations engineer or the responsible maintenance agency for specific instructions. If primary or secondary seal material are not in good condition they should be replaced, or painted if so recommended by the manufacturer. Rim vents should not be permitted to become clogged. Screens, if dirty, should be cleaned; if corroded should be replaced. Keep manhole covers tightly bolted, to minimize evaporation losses. The seal of the floating roof will compensate for reasonable variations of the tank diameter or out-of-roundness of the shell. However, the sealing mechanisms may stick or pull away from the shell if the tank is too much out-of-round. Such a condition would seriously impair the efficiency of the roof and should be corrected by leveling the tank. The ladder and ladder wheels must be free to move freely. If there is any indication of sticking, wheels and movable joints should be lubricated. If the vertical guide gasket does not fit snugly, product evaporation increases. This condition should be corrected. Check moving parts, cable and sheaves of the automatic gage. Keep roof free of debris. Keep all parts lubricated and serviced as necessary. Check pontoon interiors from deck manheads for corrosion and leakage.

2. *Precaution Against High Winds.* When floating roof tanks are expected to be subjected to hurricane conditions, high winds or heavy rainfall, it is important that advance action be taken to prevent roof damage or loss of product by imposition of excessive water loads. Under these conditions, particularly when floating roof tanks are full or nearly full causing the sealing ring to extend above or otherwise contact the top angle of the tank shell, it is imperative that the following precautions be taken: If bottom water is present, especially in a floating roof tank equipped with a siphon drain or open drain, drain off the water to the lowest practicable limit. Advance drainage not only conforms

to best operating practice but will minimize the time required for draining mounting bottom water during heavy rainfall. In order to minimize the danger of wind damage, when a floating roof is at maximum or near maximum floating height, lower the roof by transferring product to another tank in similar product service, if ullages permit. Inspect the roof to ascertain that drains are operable and emergency drains open; also assign qualified personnel to drain water from the roof and tank bottom as necessary to prevent roof damage or product loss during periods of high winds or excessive rainfall.

- b. *Cone Roof Tanks with Internal Floating Pans.*
The weather predescribed for the conventional floating roof tanks are not applicable to the internal floating pan tanks and therefore the disposal of rain and snow on the floating pan does not present operational and maintenance difficulties. However, in cold climates, screens installed in the shell vents of internal floating pan type tanks may become clogged with snow. In order to provide proper venting above the floating pan roof, screens should be inspected and cleaned as necessary. The internal floating pan roof has a stiffened rim at the outer edge of a single deck. This rim space is normally 5 inches and is closed with a continuous resilient type fabric seal. Each column supporting the fixed roof is provided with a column seal. All seals in tanks are subject to wear and should be inspected at regular intervals to assure that seals are in operating condition. Malfunctioning seals can cause the pan to hang, resulting in possible damage. Improper operation of the pan can also result if the pan is equipped with adjustable supports and these are not set at the same height. Extreme care should be taken to assure that pan supports are set at the same height.

6.8 TANK CLEANING.

See MIL-STD-457, Frequency for Inspection and Cleaning of Petroleum Fuel Operating and Storage Tanks.

6.9 BUILDING AND YARD MAINTENANCE.

- a. *Building Maintenance.* If any portion of buildings or loading platforms are not structurally

MIL-HDBK-201B
23 September 1971

safe, immediate repairs should be made. The following should be included in the maintenance checklist: Leaking walls or roof should be repaired; generally, warehouse floors are designed for a given allowable working load expressed in pounds per square foot, but if no sign now exists, the loading capacity of the floor should be determined and a warning sign posted; if the floor is overloaded, the materials stored should be redistributed, so loading will come within the design limit; if the operation of the doors and windows is faulty, this condition should be remedied. Buildings should be repainted as conditions warrant. Check all fire extinguishers, electric fixtures, outlets, and safety automatic controls.

- b. *Yard Maintenance.* The following items related to yard areas may require frequent inspection: The general appearance of a plant is a very important feature. A cluttered yard generally indicates poor and negligent operation. Any materials or equipment that cannot be stored indoors because of inadequate space, and has to be stored outdoors, should be arranged as neatly as possible, and protected from the weather and physical injury. In no case should any equipment be stored in a driveway where it presents a hazard. In order to avoid a sloppy driveway condition, the yard should be drained properly. Drainage ditches, dikes, and culverts should be kept clear. Soil erosion should be arrested. Road erosion should be arrested. Roads should be kept graded and pavement repaired. Fire hydrants should be kept cleared of weeds and other obstruction. Road signs should be provided as required for safety. Speed limits should be determined and posted. Pits should be kept clean and drained. Manifolds and exposed pipelines shall be identified according to color code. Fences, and gates around depots shall be kept in good condition.

6.10 PUMP MAINTENANCE.

In order to get the best performance from the equipment, and to minimize repairs, pumps and their associated units should be operated in accordance with the operating instructions supplied by the manufacturer. The extent of necessary maintenance and repairs to pumps will depend in a large measure on the care given the pumps during acceptance tests and

early operation. All units must be kept clean, properly lubricated, and in good adjustment. Some of the more specific items that can affect the operation of pumps and which should be carefully checked before making mechanical adjustments to the pump itself are:

- a. *Pump Piping.* Periodically check the condition of the suction and discharge piping. Clean and inspect the strainers for indications of mesh breaks. Scale or other deposits in the piping and on strainer screens will cause increased friction and decrease the pumping rate. Inspect the bypass and check valves, since their failure may result in serious damage to the pump from surge or shock pressures.
- b. *Pump Leaks.* If a pump leaks, make sure the proper type packing and lubricant is used. If leaks persist, mechanical seals should be replaced or installed.
- c. *Alinement.* Alinement of the pump and its driver should be checked periodically. Misalignment will cause vibration in the pump and its driving unit, as well as excessive bearing and packing wear; or even shaft breakage.
- d. *Pump Grounding.* If pump motors are grounded, the ground connections should be checked to make certain they are effective. If pump motors are not grounded, grounding should be installed.
- e. *Electrical.* Any defects in electrical circuits, particularly those located near pumps and manifolds, should be remedied. The overload protection devices should be checked to assure that they are operating properly.
- f. *Safety.* Any exposed moving parts on pumps, such as gears, revolving couplings, etc., should be shielded with suitable guards to prevent possible accident to personnel.
- g. *Performance.* Pumps will usually be amply tested by use under varying conditions by checking their performance as well as by periodic inspection. If several pumps in a pump-house are provided for the same service, their use should be scheduled so that each pump has about the same amount of duty on the line.
- h. *Suction Difficulties.* Suction troubles, including stoppages, will often be the cause of

MIL-HDBK-201B
23 September 1971

pump operation and maintenance difficulties. Through necessity, pumps built for one set of conditions may be operated under quite different conditions. When such a change in use occurs, due allowance must be made for the difference in viscosity and vapor pressure of the product to be handled as it may cause suction difficulties. The temperature of a volatile product such as gasoline and the elevation, above sea level must also be taken into consideration in determining whether or not the suction lift, under the existing conditions is within the suction lift capacity for which the pump is designed. Pump suction difficulties may result from an air leak in the suction line or a stuffing box. They may also be due to tramp material including scale from pipelines getting into the pump suction strainer or even into the pump. Much time and useless effort spent in locating stoppages, diagnosing faulty equipment, setting the spring tension on relief valves, etc., can be saved by the use of pressure and vacuum indicating gages. Pressure gages should have a range of at least twice the normal discharge pressure of the pumps. Several vacuum gages should be available where positive displacement pumps are installed. Connections for gages should be provided on suction and discharge sides of pumps, and provision made to protect against destructive surge vibration or forces.

- i. *Pump Testing.* When not in normal use the well type and transfer pumps serving the storage tanks should be periodically tested by operating them against a close discharge valve with the manually operated bypass valve open to allow the product to circulate back into the tank. In case of low level tank inventory, where lack of suction or lack of bearing lubrication will result, the pump should be turned by hand. A log should be maintained showing dates and time of test runs.

6.11 REPAIR AND OVERHAUL OF PUMPS.

Wear occurs in a pump as in any other piece of machinery. In order to maintain a pump at or near the efficiency it had when new and to keep maintenance cost at a minimum, periodic tests should be made to determine the total head developed and the delivery capacity of the pump. When a test indicates a very noticeable reduction in the head and capacity, it

is a sign of possible internal wear. The pump should then be opened for inspection. If remedial action is not taken immediately, total failure of the wearing parts may result, causing considerable shutdown time and excessive repair costs. The rotating element should be removed and all of the wearing parts checked for excessive clearance. Worn parts should then be replaced in order to restore the original efficiency. Manufacturer's instructions should be followed when handling major overhauling.

- a. *Stuffing Boxes and Packing.* Stuffing boxes are considered one of the vital points in the maintenance of pumping units. If normal inspection indicates that the stuffing box is operating satisfactorily with no undue amount of heat or leakage, it should not be tampered with. However, if it is found that leakage at this point has increased and cannot be reduced to normal by a slight tightening of the stuffing box glands, it is time to shut down the unit and locate the trouble. To restore the stuffing box to its original condition, check the following: After removing the old packing, check the shaft for trueness and make sure it is centralized in the bore of the stuffing box. If the shaft is off center with respect to the stuffing box bore, the packing will be tight on one side of the shaft and loose on the other side, causing excessive wear of the packing and increased leakage. Check the clearance between the throat bushing and the shaft. If the clearance is too great, the packing will be forced between the bushing and the shaft, resulting in a scored shaft which increases packing wear. Always replace old packing with new as recommended by the pump or packing manufacturer. Take steps to provide and carry in stock an adequate supply of proper type and size of packing for replacement purposes. Install the packing in accordance with instructions of the manufacturer.
- b. *Mechanical Seals.* Mechanical liquid seal systems, if properly installed, may be beneficially applied to new pumps, and some older type centrifugal pumps, replacing the old method of shaft packing. Many new pumps are now being purchased equipped with mechanical seals. An adequate supply of replacement parts for each mechanical seal in service should be carried in stock. The manufacturers will recommend the type of special parts that should be kept on

MIL-HDBK-201B
23 September 1971

hand for each seal. As seals quite often differ for each type pump, the manufacturer's name and seal number on each unit should be checked when working up a spare parts list. It is pointed out that in the event of sudden failure of the sleeve or carbon ring on a mechanical seal a sizeable leak will develop. It is hard to remedy such a leak without having replacement parts, as it is practically impossible to find a substitute for the seal during such an emergency.

- c. *Bearings.* Ball or sleeve bearings should be checked at definite intervals; lubricant should be drained from the bearing housing and the bearings and housings thoroughly cleaned. On sleeve bearings make sure the oil rings are round and free to turn with the shaft. Oil piping, coolers, and oil sumps on force feed systems should also be drained and cleaned thoroughly. Make sure the oil passages are not plugged. Check the journal and the sleeve for wear; if found excessive, replace with new parts. The ability of a sleeve bearing to carry its load successfully depends entirely on the film between the journal and the sleeve. Particular attention should be paid to lubrication during starting periods in order to prevent metal-to-metal contact. The useful life of a ball bearing correctly applied and suitably lubricated is limited only by fatigue-flaking of some part of the load carrying surfaces. Ball bearings are selected to give satisfactory operation over long periods of time. The actual length of service generally depends on whether or not the bearing has been lubricated properly.
- d. *Misalignment.* Misalignment is frequently caused by suction or discharge piping strains. Remove the suction and discharge flange bolts. If the piping springs away from the pump flanges, it is an indication that piping strains on the casing are causing the misalignment. Realign the pump and driver and line up the piping with the pump flanges so that the pipe is self-supporting and will cause no strain on the casing. If pump anchorage fastenings have loosened, causing vibrations, they should be tightened and alignment rechecked.
- e. *Centrifugal Pumps.* When tests or plant requirements indicate that the pump is not delivering its rated head and capacity but is operating at

its rated speed, the loss can generally be attributed to excessive wearing clearances at the impellers, the channel rings, or the balancing drum, or possibly to plugged impeller or casing passages. Dismantle the pump and check all wearing parts for excessive clearances, replacing worn parts when necessary. At the same time, clean the casing, removing any scale or deposits that may have formed. Also make sure the impeller passages and the liquid-seal piping or passages are clean. In the case of horizontally split casing centrifugal pumps, special attention should be paid to the clearances between the casing and the channel rings, casing rings, diffusers, and stuffing-box throat bushings. The internal sealing effected by these parts is accomplished by the vertical faces; and, therefore, sufficient clearance should be allowed on the diameter to prevent clamping of the parts by the casing when the two halves are assembled. Failure to regard this precaution may result in distortion of the sealing parts and may prevent proper compression of the flange gasket, resulting in leakage between stages or across the parting flange. If tests show frequent occurrence of reduction in head and capacity, check with pump manufacturer for alternate materials of increased hardness and resistance to corrosion and erosion. Longer life of the wearing parts will be obtained, resulting in fewer shutdowns and lower maintenance cost.

- f. *Rotary and Gear Type Pumps.* Providing the installation and application are correct, the pump will require little attention. Pumps should be lubricated in accordance with manufacturer's instructions. If it should be necessary to disassemble the pump, make sure all parts are perfectly clean before reassembly. All parts should be carefully inspected, worn parts replaced and all burrs and rough spots removed. The gaskets on the pump housing or case establish internal pumping clearance, and should be carefully replaced. All wrinkles or rough spots should be smoothed out. Do not substitute a different number of gaskets or gasket material with a different thickness than that originally installed on the pump unless internal wear indicates that a thinner gasket is necessary. In reassembling, tighten the bolts diametrically opposed to each other, pulling each bolt up evenly.

MIL-HDBK-201B
23 September 1971

6.12 WATERFRONT MAINTENANCE INSPECTIONS.

Frequent inspections of waterfront facilities and equipment are necessary to insure safe and efficient operations. Hazards, failures, and breakdowns, in this area will have greater disrupting effects than those occurring almost anywhere else in the plant. Operating personnel regularly stationed on the piers must constantly be alert to detect, report, and correct deficiencies. Supervisors should make frequent formal and informal inspections and carefully review and act on, reports submitted by other inspecting and operating personnel. Maintenance of waterfront facilities is discussed in greater detail elsewhere in those sections of this handbook, dealing with the type of facility concerned. While operating forces are not responsible for structural maintenance, they should be familiar with each of these sections to the extent that they are able to properly inspect new construction and existing facilities.

- a. *Cleanliness.* In maintenance, emphasis should be placed on neatness, order, and cleanliness. In order to avoid vapor accumulation drip pans should be kept clean and free of accumulated oil drippings.
- b. *Hose-handling Equipment.* Hose-handling equipment should be serviced frequently. Cables on hose rigging equipment should be oiled and free from rust, and should be tested at least semiannually.
- c. *Bonding Cables.* The pier bonding system should be tested periodically for resistance and continuity to insure against broken wires and loose fittings.
- d. *Hose Testing.* Hose must be tested at intervals of 3 months to 1½ times their working pressure, not to exceed 125 p.s.i. If necessary to test at a pressure in excess of 125 p.s.i., hose design specifications should be ascertained before testing. Hoses should be marked with the date tested.
- e. *Communications.* Communication facilities must be kept in good operating condition and only approved equipment used where gasoline and jet fuel are handled.
- f. *Electrical System.* Electrical systems should be carefully inspected, with special attention given to explosion-proof fixtures and fittings.

g. *Fire-fighting Gear.* Fire-fighting gear should be inspected regularly and always kept ready for use.

h. *Cathodic Protection.* Cathodic protection systems must be inspected and maintained by qualified personnel.

6.13 BARGES AND TANKERS.

Vessels are designed as clean or black according to the grade of product last carried. Clean vessels are those in refined product service and black vessels are those in crude and black fuel oil service.

- a. *Tank Cleaning and Gas Freeing.* The purpose of tank cleaning and gas freeing is to insure that the barge's or ship's tanks are in condition to receive cargo without contamination of products, and to lessen the hazard to men and vessels due to the accumulation of flammable vapor-air mixtures. The life of the vessel depends upon the treatment given its tanks. For this reason, tank vessels are usually semi-permanently placed in either clean or black oil service. Black-oil products create a sludge which cannot, by regulations, be discharged with the general cargo. This sludge, therefore, has to be steamed or washed down to get it out of the tanks. Tanks carrying gasoline cargo are subject to corrosion and collection of loose rust. This rust must be removed at regular intervals to prevent product contamination and further release of flammable vapors even after the tanks are normally cleaned. The cleaning of tank compartments by any method reduces the life of the vessel and therefore should be deferred as long as the cargo can be handled without contamination. However, cleaning is required when danger of contamination exists; and coupled with gas freeing, it is necessary prior to internal inspections or repairs to tanks.
- b. *Corrosion of Vessel's Tanks.* A highly corrosive gas is formed when petroleum vapors are mixed with a slight amount of oxygen, especially when the vapors are present over stagnant sea-water ballast. Bottom plating does not corrode evenly, but becomes heavily pitted due to dilute acid formed by sweating and saltwater ballast mixed with the residue from cargo remaining in tanks or probably by a weak acid liberated from sea-water ballast.

MIL-HDBK-201B
23 September 1971

Ferrous (iron) corrosion is of consequence mainly when it occurs with gasoline and jet fuel. This is especially noticeable in cases of tanks with thick, brittle, dark rust layers. In tank inspection, care should also be taken to observe the conditions of rust on bulkheads, beams, and ladders. When large amounts of rust are found, the inspector should have samples of the rust analyzed to determine its nature and possible effects on the cargoes. Cargoes which are loaded into tanks containing corrosive agents may be so contaminated that they become unacceptable.

- c. *Preparation of vessel's tanks.* In the preparation of tanks for the next cargo, each tank should be evaluated individually, with due consideration being given to the product and grades last carried, as well as to the product and grades to be loaded. Any admixture of even a remainder (a heel) of one product with a superior grade of cargo being loaded is undesirable and should be prevented especially when loading gasoline and jet fuel. Table 1 is a guide for preparing cargo tanks for receipt of petroleum products.

6.14 PIPELINES.

Pipelines must be properly identified in accordance with MIL-STD-161. They should be tested periodically for leaks, using the normal testing procedures as outlined by the military activity concerned. In some cases this will be accomplished by applying pressure at $1\frac{1}{2}$ times the normal working pressure but not less than 100 p.s.i. Consideration will be given to pressure increases or decreases which are caused by changes in ambient temperature.

In conducting this test a 10 percent drop in pressure will be allowed for the first 2 hours after the valves have been closed and pressure established. If the pressure drop in this time exceeds 10 percent, then a leak is probably indicated. The block valves should first be checked for proper closure and the test repeated. If leaks are still indicated, the leak must be located and repaired. After repairs have been completed, the test must be repeated until satisfactory results are obtained. These tests should be recorded and covered by report. Leaks in valves and piping should be repaired promptly.

If the pressure-relief equipment or bypass valves are improperly set or installed, excessive pressure, due

to product expansion, will result. Therefore, some means of pressure relief is necessary and may be accomplished by installing bypass with a pressure-relief valve around the line valve, or by replacing a line valve with one having built-in pressure relief.

If the pipe supports have settled or become dislodged, they should be repaired or replaced. Piping should neither sag nor be free to sway.

Pipelines should be painted for their protection, when necessary, utilizing the prescribed coating materials. Pipes, hangers, and supports under piers which are submerged by high water may require coating with an antioxidation solution. When underground lines are exposed for inspection or repair care should be taken to prevent small breaks in the protective coating. Such breaks permit a rapid localized electrolytic corrosion.

Economy of operation requires that steam lines and steam tracer lines be insulated and that such insulation be properly maintained. Expansion joints of certain types and clamp type couplings require inspection and takeup. This may be done by operating personnel. When limit of packing takeup is reached requiring repacking or when line strains or undue movements are observed, the supervisor should be notified at once.

A written permit must be obtained from the depot fire chief or officer in charge and posted in the job vicinity before any welding, flame cutting or burning, sand blasting, riveting, or any other work is started which may be a source of ignition in any potentially hazardous area. Except where emergency conditions make it absolutely necessary, no welding, burning, cutting, etc., shall be performed on lines containing flammable products. In the case of welding attachments to a full line in an emergency, if lines cannot be drained and made gas free, or displaced with water, the product shall be rapidly circulated during work progress with pressure limitation strictly enforced. Such work will be performed only by the most skilled men under competent supervision and with all fire and safety aids provided, ready for immediate use. Welding side connections or thin walled lines is very hazardous due to possible burn through.

- a. *Plug Valve.* Plug valves in light product service require frequent servicing and adjustment, because the product removes the lubricant which serves as a packing and seal. Plug valves should be lubricated at regular intervals by use of pressure gun or stick lubricants. Only non-corrosive lubricants of high quality should be

MIL-HDBK-201B
 23 September 1971

TABLE I. GUIDE FOR PREPARATION OF CARGO TANKS

Product to be loaded	AvGas MIL-G-5572	White Gas VA-G-109	MotGas MIL-G-3056 VA-G-76	JP-4 MIL-T-5624	JP-5 MIL-T-5624	Kerosene AVK-210	Fuel oil AVT-805 Gr 1 & 2	Nav. distillate MIL-T-31937 (SHIPS)	Diesel fuel MIL-T-16884 AVT-800	Fuels MIL-T-859	Jet fuel MIL-T-859
AvGas MIL-G-5572	A	B	A	BX	BX	B	B	B	B	T	B
White Gas VA-G-109	A	A	A	BX	BX	B	B	B	B	T	B
MotGas MIL-G-3056 VA-G-76	A	B	A	BX	BX	B	B	B	B	T	B
JP-4 MIL-T-5624	A	A	A	X	BX	B	B	B	B	T	B
JP-5 MIL-T-5624	A	A	A	X	X	A	A	A	A	T	A
Kerosene AVK-210	A	A	A	A	A	A	A	A	A	T	A
Fuel Oil MIL-T-859	C	C	C	CX	CX	C	A	A	A	T	A
Gr 1 & 2	C	C	C	CX	CX	C	A	A	A	T	A
Diesel fuel MIL-T-16884 VA-T-800	D	D	D	DX	DX	D	D	C	D	T	A
Fuels MIL-T-859	D	D	D	DX	DX	D	D	C	D	T	A
Gr 4 & 6	D	D	D	DX	DX	D	D	C	D	T	A
Commercial Diesel fuel	D	D	D	DX	DX	D	D	A	D	T	B
MotGas, Jet Fuel, Gr 1 & 2	D (1)	D (1)	D (1)	DX (1)	DX (1)	D (1)	D (1)	C (1)	D (1)	T (1)	C
Gr 4 & 6	B	B	B	(2)	(2)	B	B	B	B	T	B

EXPLANATION OF SYMBOLS USED IN TABLE I. GUIDE FOR PREPARATION OF CARGO TANKS

- SYMBOL** **EXPLANATION**
- A No special preparation required if lines have been dropped and tanks stripped
 - B All cargo and vent lines will be drained of previous product and flushed with cold water. Cargo tanks will be thoroughly machine washed using cold water. Cargo tanks must be free of water, loose rust, sludge, mud, silt, etc.
 - C The same as for "B", except that hot water will be used instead of cold. If tank interiors are coated, water temperature should not exceed 135°F.
 - D Cargo tanks and systems will be processed in accordance with the instructions contained in NAVSHIPS 0900-016-0010, Manual for Cargo Tank Cleaning, dated 1 Dec. 1966.
 - E Cargo tanks and systems must be cleaned in such a manner as will remove all rust, scale, sediment, and all traces of previous cargo and water.
 - X After dropping lines, hand hose tank bottoms and remove all puddles of water from bottom surfaces.
 - T Vessels which have carried linseed oil, cottonseed oil, tar, wax, molasses or other products which would probably contaminate the cargo to be loaded will be rejected unless they have been cleaned in accordance with D and have carried (after cleaning) at least two cargoes of clean product.
 - S Vessels will not go directly from grain to JP-4 or JP-5 service.

MIL-HDBK-201B
23 September 1971

used. Valves should be lubricated to turn freely through a 90° arc. Bonnet collar may be loosened to free valve as it allows plug to be lifted from seat. This should normally be done by those responsible for operational maintenance. The supervisor should be advised of any improper functioning or leaking valves. Plug valves in aviation fuel service usually require more frequent lubrication and attention than those in other type service. When conditions permit, plug valves in all types of service shall be periodically test-opened and closed to facilitate their operation. Plug valves that are frozen can usually be freed enough to turn by jacking them with lubricants.

- b. *Gate Valve.* Gate valves require servicing to lubricate steam threads and gears (depending on valve type) and adjustments of stuffing box to prevent leaks around the stem. Repacking of stuffing box will be done by maintenance personnel.
- c. *Pressure-relief Valve.* Most pressure-relief valves are factory set. They should not be altered or adjusted except by specifically authorized personnel who will be supplied with reliable test gages or their equivalent.

6.15 TANK TRUCKS.

Operators of tank trucks should carefully inspect their vehicles prior to the beginning of daily operations and promptly report to the supervisor any failure or improper working condition of mechanical and safety equipment. A checkoff list for this purpose should be provided as part of operation instructions to operators.

a. *Servicing.* In addition to inspections by operators, tank trucks should be serviced by the maintenance personnel every 1,000 miles or at least once each month. This service includes, but is not restricted to, inspection of the following items:

1. Horn, headlights, tail lights, warning lights, and reflectors.
2. Fire extinguisher to assure that it is filled, in place, and in operating condition.
3. Windshield wiper and tires.
4. Steering mechanism.

5. Coupling devices on trailers and semitrailers.
6. Tanks, lines, and valves should be examined for leaks.
7. Brakes tested for proper performance.
8. Bonding cable to insure proper continuity at low resistance.
9. Filters and strainers to see that they are clean and free flowing.
10. Drain water from dehydrator, when dehydrators are provided.
11. Air eliminator floats and valves to assure cleanliness and free operation.
12. Meters (test periodically).
13. Spare light bulbs, fuses, flares, flags, tools, wheel chocks, tire chains, and other items, for adequacy and proper condition.
14. Pumps and power take-offs for proper functioning.
15. Remove stones from between tires on dual wheels.

b. *Overhaul.* During periodic overhaul of trucks, the pumps, lines, filters, dehydrators, air eliminators, etc., should be tested, inspected, and overhauled as required. Handles, handrails, ladders, and man walks should be inspected to make sure they are secure and in good order. Exhaust pipe and muffler should be kept tight and in good repair.

c. *Special Precautions.* Before hot work repairs or other work is done on the tank or other part of the truck, when there is danger of igniting vapors, the tank must be gas freed. (See API Accident-Prevention Manual No. 13-Cleaning Mobile Tanks Used for Transportation of Flammable Liquids (Section A Tank Vehicles).) No hot work should be done on any tank until a gas free test has been made and a hot work permit secured from the officer in charge or the fire chief. When repairs are to be made by an outside party, the truck tank and piping should first be gas freed, otherwise a notice should be attached to the truck warning the repair crew that the tank might contain an explosive mixture.

MIL-HDBK-201B
23 September 1971

6.16 TANK CARS.

Most tank cars are owned by private corporations. Regardless of whether they are commercially or Government owned an inspection should be made of the outlet valve, heater coils, and tank for leaks. Dome safety valves should be set to release at specified pressures.

The same rules for hot work and other safety items that apply to tank truck maintenance should be followed in working on tank cars.

6.17 CHANGING PRODUCT SERVICE OF TANK TRUCKS AND TANK CARS.

When inspection reveals the interior condition of the tank truck or tank car is not satisfactory for the product to be loaded, it should be rejected and subjected to cleaning or placed in a product service for which it is suitable. Recommended cleaning practices for shifting products in vehicles are shown in Table II.

6.18 LOADING RACK.

a. *Inspections.* In order to insure safe and efficient operation frequent inspection and tests of the following items should be made:

1. All bonding cables or wires should be tested and maintained in good repair to assure proper grounding. Inspect entire bonding system monthly to insure proper connections.
2. Defective or leaking loading sleeves should not be used.
3. Valve-control chains or ropes which operate quick-acting valves at loading racks should be inspected frequently and maintained in good repair.
4. Water should be drained from meters and air eliminators frequently, especially in cold weather, to avoid freezing. Keep strainers clean, if mesh is broken the strainer basket should be replaced at once.
5. Keep rack area clean and free of items that might become safety or fire hazards. Clean up product spills promptly.
6. First aid fire fighting equipment must be properly maintained. Make sure operating

and safety instructions are posted. If not legible replace with new set of instructions.

b. *Repairs.* The following repairs should be accomplished promptly when required:

1. Repair all leaking valves and piping.
2. Leaks in loading arm joints shall be repaired, replacing packing if necessary. If swing joints cannot be maintained in a tight condition, they should be replaced.
3. If loading arm cannot be prevented from leaking because of excessive dents or scratches on sliding tubes, the tubes should be replaced.
4. In order to prevent contamination, loading arms must be properly identified as to product handled.
5. Meters and their shaft packings should be inspected for small leaks.
6. Where air eliminators leak or spray product excessively, units shall be promptly examined to determine cause of the leak. Improperly adjusted or faulty floats and float operated valves are usually the cause of excessive leaks or spray. The air eliminator vent pipe may be connected with a drum or slop tank, in this case overflow from the air eliminator should discharge through a vantage or into an open funnel before flowing through piping to the drum or slop tank so that operation of the vents may be observed. Vent lines from air eliminators in gasoline service should not be manifolded with those in nonvolatile products service.
7. If meters are not accurate, they should be adjusted, tested and resealed.
8. Missing or damaged grounding clamps must be immediately replaced. Link chains should not be used between clamp and permanent ground wire. Where such chains exist, they should be replaced with continuous flexible cable. Install counterweighted arrangement to prevent the clamp lying on ground when not in use. Overhead ground wire reel may be installed, if desired.
9. Switches and pilot lights should be replaced if defective.

MIL-HDBK-201B
 23 September 1971

TABLE II. CONVERSION CHART FOR TANK CARS AND TANK TRUCKS

Product to be loaded	AvGas MIL-G-5572	MoGas MIL-G-3056 VV-G-76	Jet fuel MIL-T-5624 JP-4	Jet fuel MIL-T-5624 JP-5	Petrol solvent or paint thinner	Kerosene VV-K-211	Diesel fuels MIL-F-16884 VV-F-800	Burner fuel oil VV-F-815 Gr 1 & 2	Burner fuel oil VV-F-815 Gr 4.5 & 6	Lubricating oils (1)
AvGas MIL-G-5572	Drain Empty	Drain Empty	Drain Empty Flush	Drain Empty Flush	Drain Empty Flush	Drain Empty Flush	Drain Empty Flush	Drain Empty Flush	Drain Empty Flush	Drain Empty Flush
MoGas MIL-G-3056 VV-G-76	Drain Empty Flush	Drain Empty	Drain Empty Flush	Drain Empty Flush	Drain Empty Flush	Drain Empty Flush	Drain Empty Flush	Drain Empty Flush	Drain Empty Flush	Drain Empty Flush
Jet Fuel MIL-T-5624 JP-4	Drain Empty Flush	Drain Empty	Drain Empty	Drain Empty Flush	Drain Empty Flush	Drain Empty Flush	Drain Empty Flush	Drain Empty Flush	Drain Empty Flush	Drain Empty Flush
Jet Fuel MIL-T-5624 JP-5	Drain Empty Flush	Drain Empty	Drain Empty	Drain Empty	Drain Empty Flush	Drain Empty Flush	Drain Empty Flush	Drain Empty Flush	Drain Empty Flush	Drain Empty Flush
Petrol Solvent or Paint Thinner	Drain Empty Flush	Drain Empty	Drain Empty Flush	Drain Empty Flush	Drain Empty	Drain Empty Flush	Drain Empty Flush	Drain Empty Flush	Drain Empty Flush	Drain Empty Flush
Kerosene VV-K-211	Drain Empty Flush	Drain Empty	Drain Empty	Drain Empty	Drain Empty	Drain Empty	Drain Empty	Drain Empty	Drain Empty	Drain Empty Flush
Diesel Fuel MIL-F-16884 VV-F-800	Drain Empty Flush	Drain Empty Flush	Drain Empty Flush	Drain Empty Flush	No Load	Drain Empty Flush	Drain Empty	Drain Empty	Drain Empty	Drain Empty Flush
Burner Fuel Oil VV-F-815 Gr 1 & 2	Drain Empty Flush	Drain Empty Flush	Drain Empty Flush	Drain Empty Flush	No Load	Drain Empty Flush	Drain Empty	Drain Empty	Drain Empty	Drain Empty Flush
Burner Fuel Oil VV-F-815 Gr 4.5 & 6	No Load	No Load	No Load	No Load	No Load	No Load	No Load	No Load	Drain Empty	No Load
Lubricating Oils	No Load	Drain Empty Flush	No Load	No Load	No Load	No Load	Drain Empty Flush	Drain Empty	Drain Empty	Drain Empty

(1) Equipment carrying lubricating oil will be dry and free from loose rust, scale and dirt.
 (2) Note: Petroleum products will not be loaded into transportation equipment that previously carried liquid fertilizer, caustics, or acids.
 (3) Flush. Use only a quantity of product to be loaded sufficient to clean tank bottoms, lines and manifold.

MIL-HDBK-201B

23 September 1971

10. All electrical equipment at loading racks, including telephones, should be of an approved type.
11. If any portion of the loading rack is damaged or presents a hazard, repairs should be made immediately.
12. If swing joints and self-closing valves do not work properly they should be repaired or, if necessary, replaced.
13. Railroad trackage including bumpers must be maintained in good condition.

6.19 BULK LUBRICATING OIL.

Lubricating oil is presently stored in bulk at a limited number of oil depots. However, a change from drum to bulk storage should not be made without first obtaining approval through appropriate military departmental channels. Where lubricating oils are stored in bulk, the supervisor of such storage should prepare inspection data for the guidance of the personnel in operating, servicing, and maintaining lubricating oil storage equipment. Particular attention should be given to the following:

- a. *Heating Coils.* Exterior corrosion of tank heating coils will not normally occur while oils are stored in tanks. In the event a tank remains empty for an extended period of time, the heating coils should be tested for leaks, and any defective coils or coil sections replaced.
- b. *Cleaning Lines.* When it is necessary to clean lines, manifolds, and pumps, for example, to change the service from one grade of lubricating

oil to another, the lines, manifolds, and pumps should be blown with air to displace the oil they last contained and should be flushed with the product to be next used. When lines are changed from additive oil service to non-additive oil service or when unusual circumstances exist, the appropriate cognizant departmental activity should be contacted for specific cleaning instructions. Lines that have contained fuel oil, jet fuel, or gasoline should not be used in lubricating oil service, unless every trace of the oil previously handled can be completely removed from the line.

- c. *Cleaning Lube Oil Tanks.* Tanks that have not previously contained lubricating oil should be thoroughly cleaned, dried, and inspected before placing in lubricating oil service.

Tanks, lines, manifolds, and pumps being changed from one grade of lubricating oil to another shall be pumped dry before the change is made. Due to the water tolerance of lubricating oil and some of the additives in some types of lubricating oils, the possibility of contamination is ever present. Extreme care must be exercised, therefore, in the transfer of these products to or from storage.

- d. *Additional Precautions.* Dust caps must be kept on all fill line and hose openings when not in use to prevent dust and dirt contamination. Since lubricating oil appreciably clings to the walls of lines, separate lines should be used for each product handled. Water draw-off facilities must be available and in operation on all tanks. Vents should be goose neck type facing downward and properly screened.

SECTION IV. CORROSION CONTROL AND CATHODIC PROTECTION

6.20 GENERAL.

A program of corrosion control is necessary to prevent rapid deterioration of metal components of a fuel system, such as storage tanks and pipelines, and to avoid increased maintenance and replacement problems, operating hazards, contamination of product, and possible losses. Corrosion problems in the system arise chiefly from corrosive elements in petroleum products and from soil corrosion.

- a. *Corrosion from Products.* Sulfur compound, oxygen, and salt water are corrosive elements in products. The sulfur compounds may be carried over from crude oils or introduced during the refining process. Oxygen, which is more soluble in lighter petroleum products than in water, especially salt water, causes considerable corrosion. For this reason, the use of salt water to maintain water bottoms in tanks and as a moving agent to transmit petroleum products

MIL-HDBK-201B
23 September 1971

through pipelines is prohibited. Fresh water bottoms in storage tanks are permitted only as a temporary measure when the tank bottom is known to be leaking and repairs cannot be made until all product has been removed.

b. *Corrosion from Soil.* Conditions of underground structures and their surroundings may cause galvanic action or electrochemical action which may cause rapid corrosion. When electrochemical reaction takes place, electric current flows from the metal and through an electrolyte to points where the current is grounded. During this process, small particles of metal go into solution with the electrolyte and are finally precipitated out as rust or iron salts. When this electrolytic process has continued for sometime, weak spots and holes occur in the metal at the points where it has been dissolved by electrochemical action. An anodic or positive loss of metal occurs where current flows out of the metal surface into the earth. However, there is no damage to the cathodic or negative areas where the current flows from the soil to the metal. A current of one ampere flowing for a year can cause the loss of 20 lbs. of metal, and small values of current can result in serious corrosion damage when the current discharge is from small areas, such as flows in pipe coating. Electrochemical actions are listed below:

1. Varying strata of contacting soil, from the bottom to the top of the structure.
2. Varying soils along the length of the structure.
3. Varying soil moisture between the top and the bottom.
4. Difference in soil aeration between the top and the bottom.
5. Stones, roots or other refuse in contact with the structure.
6. Cinders in contact, setting up strong galvanic action with the metal, with possibly some sulphuric acid reaction.
7. Paint, oil, grease or other coatings, not completely continuous.
8. Mill scale partially off.

9. Voids in the backfill, where no soil contacts the structure.
10. Imperfect mixture of the steel structure itself, such as particles of copper on the surface (dissimilar metals).
11. Rusty steel in contact with new steel (dissimilar metals).
12. Bright scratches in the steel, bright threads on pipe, etc. (dissimilar metals).

6.21 PAINT, COATINGS, AND WRAPPINGS.

All underground or underwater ferrous pipe lines, valves, and fittings, as well as those exposed to moist salt-laden atmosphere and salt spray, are subject to deterioration due to corrosion caused by electrochemical reaction. If these metal surfaces were perfectly protected there would be no electrochemical reaction, and consequently no resulting corrosion. Above ground ferrous pipelines, valves, and fittings are subject to corrosion due to oxidation. To protect against these causes of deterioration, exposed surfaces are painted or coated. For underground piping, it is difficult to obtain a perfect coating that is impervious to all soil solutions and at the same time capable of withstanding the stresses it will encounter. Corrosion protection is especially needed on submarine pipe lines and lines which are subject to water cover within the tidal range.

A poor coating, such as a single coat of paint before the pipe is put underground, is worse than none, since invariably portions of the pipe will be scraped bare or become so in time, with local galvanic action being added to other electrical current present. Without a good coating (and cathodic protection) the steel may best be left bare, with generally no more than usual over-all slow corrosion.

There is, however, another factor. In locations where it seems that cathodic protection may be necessary, if the pipe is left bare, any later cathodic protection will be difficult and very expensive, due to the large exposed area of metal and large protective current required. In such dubious cases of corrosive soils or conditions, the preferred procedure seems to be to coat well, with at least provisions for future cathodic protection without much more than normal coat when it is applied.

MIL-HDBK-201B
23 September 1971

6.22 CATHODIC PROTECTION.

When two dissimilar metals are in electrical contact underground (usually in wet or damp soil), galvanic action and corrosion of one of the metals (the anodic metal) may be expected. The following table lists the more commonly used metals in their Electromotive Series. Any metal below another in the table will be anodic to any metal above it and if connected together underground in damp or wet soil will corrode and protect the metal above it. The amount of galvanic action (and corrosion of the lower metal) increases as they become further apart in the table. Nickel and Chromium steels fall at various points in the table, depending on their composition.

CATHODIC END (will be protected)

Graphite
Carbon
Monel
Nickel Silver
Bronze
Copper
Brass
Tin
Lead
Lead-tin solder
Cast-Iron
Copper steel
Carbon steel
Cadmium
Aluminum
Zinc
Magnesium

It must be recognized that no coating or wrapping, hot or cold, is ever perfect, since even if so when first applied, movement or vibration of the structure in the ground, movement of the soil and abrasion or puncture by stones, etc., will soon create holidays or voids in the coating.

If cathodic protection is not applied and since electrical current is present in the structure, there is nothing to prevent this current from leaving the structure through the holidays, taking with it minute particles of metal, ending up with a pit or a hole. This is particularly apparent with cross-country pipelines through different types of soils. The high ampere current may travel along the pipeline in dry soils for some distance without causing any particular harm,

but upon reaching a marsh, for instance, with low resistance soil, its natural inclination is to go from the pipe into the soil, seeking the path of least resistance to return to its source to complete the electrical circuit.

If the current is strong, it can cause severe localized corrosion as it leaves the pipe through a holiday, with often surprising results in the size of the hole in the pipe which is very rapidly created. Should the current be mild, the action is less, but it nevertheless exists where low resistivity soil causes the current, always seeking the path of least resistance, to leave the metal structure.

The basic theory of cathodic protection is to surround the structure by an electrical blanket strong enough to overpower the currents seeking to leave the metal to go into the soil and to prevent them from doing so. This is accomplished by putting electrical current into the soil, so that it flows to and into the structure. The protective current may be obtained by the galvanic action between magnesium anodes and the steel structure or by a rectifier to convert A.C. current to direct current, which is put into the soil through a scrap metal graphite ground-bed. The first or galvanic action method consists of attaching magnesium anodes (aluminum and zinc are less effective) to the steel structure by insulated wires. The resulting galvanic action between the magnesium and the steel causes current to flow through the soil from the magnesium to the steel structure, which it blankets and protects, the current then returning through the insulated wire to the magnesium, to complete the circuit. The action is very similar to that of the ordinary dry battery.

It is recommended, because of the complications involved in applying this type of protection, that an engineer experienced in this field make the preliminary measurements on which to base the design, and also supervise the installation of the system.

6.23 MAINTENANCE OF CATHODIC PROTECTION EQUIPMENT.

Where a Cathodic Protection System has been provided, it must be maintained in good order to remain effective. It is also necessary to maintain good records of current density and potential throughout the system. A major departure from normal operating characteristics may be caused by failures or faults in system components.

CHAPTER 7. HAZARDS CONNECTED WITH PETROLEUM FUELS

7.1 GENERAL.

The principal hazards and their preventatives associated with petroleum fuels and related equip-

ment are discussed briefly herein. It is essential that personnel handling these products become familiar with these hazards and their safety aspects.

SECTION I. HYGIENIC (HEALTH) ASPECTS

7.2 FUEL OIL

Contact of fuel oil with the skin should be avoided; although such contact may not be immediately irritating or harmful. Should contact with fuel occur, the affected area should be cleaned promptly. Most of the fuel oil may be wiped off with a dry rag and the remainder removed with a liberal application of soap and warm water. Under no circumstances should gasoline or solvents be used. Getting fuel oil into the mouth and nose must be avoided; medical aid should be secured immediately if these conditions occur. Oil vapors may be toxic even though far below the explosive limit. Men should not be permitted to work in spaces where hydrocarbon vapor concentrations exceed 500 parts per million by volume unless they are protected by an air supplied respirator. It is recommended that men be permitted to work only in well ventilated spaces where the hydrocarbon vapors are at or below the permissible limit. Where work must be done at atmospheres below the lower explosive limit but above the permissible limit for safe breathing, men must wear air supplied respirators. Work in tanks, compartments, sumps, etc., shall be done only under expert supervision.

7.3 DIESEL FUEL.

Diesel fuel is not especially irritating to the skin but unnecessary contact should be avoided. It should be kept out of the mouth, eyes, ears, and nose but is not violently poisonous. Contact with open cuts may prove irritating. When those conditions occur, procedures for fuel oil as described in paragraph 7.2 should be followed. Diesel fuel vapor is toxic. Therefore, the same precautions, regarding men working in spaces where hydrocarbon vapor concentrations exceed 500 parts per million, or in tanks, compartments, sumps, etc., apply equally to diesel fuels.

7.4 KEROSENE.

Although kerosene may not be completely irritating or harmful to the skin, contact should be avoided. Should contact occur, the affected area should be cleaned promptly with a liberal application of soap and warm water. Contact with the eyes or cuts is irritating. If this occurs, procedures described for fuel oil in paragraph 7.2 should be followed. Getting kerosene into the mouth should be avoided; it is recommended that medical aid be secured immediately if any is swallowed. Kerosene vapors are toxic so the same precautions regarding men in spaces where hydrocarbon vapor concentrations exceed 500 parts per million in tanks, compartments, sumps, etc., described for burner fuel oils, apply equally to kerosene. The hazards connected with handling kerosene are similar to those of No. 1 burner fuel oil.

7.5 GASOLINE.

The concentration of gasoline vapors which can be tolerated by man is far below that required to produce combustible or explosive mixtures with air. Even one-tenth of the amount necessary to support combustion or to form an explosive mixture is harmful if inhaled for more than a short time, causing dizziness, nausea, and headache; large amounts act as an anesthetic and may cause unconsciousness. The occurrence of any of the symptoms mentioned above among men who are handling gasoline or who are within an area in which gasoline is handled or spilled should be taken as a warning of the presence of dangerous amounts of gasoline vapor in the air. All exposed personnel must be sent out of the area until the vapors have been cleared. Recovery from early symptoms is usually prompt after removal to fresh air. If men have been overcome, they should be given first aid at once. Medical attention should be obtained promptly. First aid consists in the removal

MIL-HDBK-201B
23 September 1971

of gasoline from the skin (if the skin or clothing have been contaminated in a fall or other accident), the prevention of chilling, and application of artificial respiration if breathing has ceased. Lead poisoning is not to be feared from the inhalation of vapors of lead-treated gasoline given off from open containers, however, hazardous exposure to the vapors of tetraethyllead may occur when work is carried on regularly over a period of weeks or months in an enclosed or inadequately ventilated area within which gasoline is spilled frequently and in considerable quantity. The filling of drums and small cans with lead-treated gasoline in an enclosed space presents a potentially serious problem of exposure to the vapors of gasoline and tetraethyllead. The danger of entering a tank that has been used for the storage of gasoline may be very great, because of the chance of exposure to toxic concentration of gasoline vapors as well as to dangerous quantities of lead vapors in the air and in the sludge, wet or dry, in the bottom of such tanks. No person shall be permitted to enter such a tank without special equipment and complete instructions for its use. The same general precautions regarding men working in spaces where hydrocarbon vapor concentrations exceed 500 parts per million in tanks, compartments, sumps, etc., apply to gasoline. Gasoline is exceedingly irritating when swallowed. If gasoline should be swallowed, vomiting should be induced. Medical attention must be obtained as soon as possible. Gasoline will cause severe burns if it is allowed to remain in contact with the skin, particularly when the contact is maintained under soaked clothing or gloves. Clothing or shoes through which gasoline has soaked should be removed at once. Repeated contact with gasoline removes the protective oils from the skin, producing drying, roughening, chapping, and cracking. Skin infection may follow this damage to the skin. A severe irritating of the skin may develop beginning usually on the hands and perhaps extending to other parts of the body. These effects upon the skin are due to the gasoline and not to the small amount of lead that has been put into lead-treated gasoline. As soon as possible after contact, the gasoline should be removed from the skin, preferably by washing with soap and water. Rags or waste wet with gasoline must not be put in a pocket, but must be disposed of at once. Soaked clothing must be kept away from flame or sparks, and should be washed out thoroughly with soap and water as soon as possible. If gasoline comes in contact with the eyes, they should be washed with

liberal amounts of tepid water. Medical attention should be obtained promptly.

7.6 JET FUELS

Jet fuels do not contain tetraethyllead. However, they may contain more toxic aromatics than aviation gasolines. They should, therefore, be handled with the same health precautions as apply to leaded gasolines. They should not be used for cleaning purposes. The same precautions with respect to the handling of leaded gasolines apply equally to the handling of jet fuels. These precautions include all aspects and are particularly applicable to the inhalation of vapors, skin irritations, and container hazards.

7.7 CONTAINERS

Gasoline containers, trucks, or even gasoline pipelines, will not be used for the storage or transportation of other than petroleum products except on the basis of specific orders. Of special importance is the possible use of such equipment for the transportation of drinking water. If, in an emergency, it should be necessary to transport drinking water by these means, the water will have to be treated by suitable methods for the removal of gasoline and lead. Specific instructions for this purpose are contained in the Corps of Engineers' Water Purification Training Manuals. The following precautions, however, are particularly applicable to drum filling and drum reconditioning procedures: If spillage of gasoline or jet fuel cannot be prevented under the existing conditions, to the extent that the workmen cannot avoid contact with the product, and remain free from exposure to toxic vapors, the following precautions should be taken:

1. Clothing and shoes used by personnel during the filling operations should be kept clean and suitable for regular use.
2. Facilities for personnel washing, bathing, and changing clothing at specified intervals should be provided. Such facilities should be as good as circumstances permit so as not to discourage their use.
3. Personnel should not be permitted to work for longer periods than are safe under the exposure to the vapors of gasoline or of tetraethyllead. This may require interrupted periods of work. In general, avoidance of the

MIL-HDBK-201B
23 September 1971

acute toxic effects of exposure to high concentrations of gasoline necessitates a brief period of exposure followed by a corresponding or perhaps somewhat longer period of freedom from exposure.

4. Medical supervision of personnel should be provided at least to the extent of the performance of the following services:
 - (a) The selection of personnel free of well defined organic disease of the central nervous system, kidneys, blood vessels, and blood.
 - (b) Examination, care, and consideration of persons who complain of illness or who may actually develop illness associated with their work.
 - (c) In addition, all personnel frequently engaged in gasoline filling operations, where body contact with gasoline is unavoidable, should be examined

thoroughly by a competent physician for possible lead absorption at least semiannually.

5. Filled drums must be carefully handled to prevent damage or injury to personnel. All personnel handling filled drums should be trained and supervised to insure careful and safe handling in transit to the storage location or when loading into trucks, barges, or freight cars.

7.8 SAFETY PRECAUTIONS IN CLEANING TANKS.

Anyone who enters a tank which has contained leaded gasoline should wear a hose mask of the blower type through which air is supplied under positive pressure. He should continue to wear this equipment until all material which may give rise to lead vapors has been removed. Leaded gasoline tanks should be cleaned under departmental technical supervision.

SECTION II. FIRE PREVENTION AND FIRE EXTINGUISHMENT

7.9 GENERAL.

Fire prevention and fire extinguishment are specialized subjects which are treated extensively in other handbooks, manuals, and texts. This section contains a brief outline of the types of fires most likely to occur at oil depots. Due to the flammable nature of the products being stored and handled and the possible source of ignition, fire prevention is one of the most important items to be considered at a military fuel depot.

Operating personnel shall exercise every possible precaution especially during fuel-handling operations, both for protection of life and to safe-guarding valuable products, Government property, and equipment. Because human failure is responsible for the majority of fires that occur, personnel should be well trained and made aware of the potential hazards.

7.10 FIRE AND EXPLOSION HAZARDS.

- a. *Fuel Oil.* Because of their relatively high flash points, boiler fuels oils are not flammable at ordinary temperatures, but they may be readily

ignited when admixed with lower flash point products, such as gasoline, kerosine, solvents, etc. When such products are present, serious fires may result. When fuel oil is stored at a temperature well below its flash point, its vapor, though combustible in nature, is too diluted to ignite or burn. In other words, the vapor-air mixture in a tank of fuel oil at a temperature sufficiently under its flash point is below the lower limit of explosibility. A difference in temperature of 15°F under the flash point will usually provide the needed safety factor. The degree of safety depends on the composition of the oil, and whether or not it has been contaminated by small amounts of volatile material. Burner fuel oils are not volatile enough at ambient temperatures usually encountered in storage to be ignited or burned unless contaminated with a more volatile product. However, if they are heated above their fire points, they can be ignited readily and will support a fast growing hot fire that may be difficult to extinguish. The No. 1 and No. 2 fuels spread rapidly either on land or water and

MIL-HDBK-201B
23 September 1971

burn completely, whereas a No. 5 or No. 6 fuel oil may go out of its own accord.

b. *Diesel Fuel.* Diesel fuels are not volatile enough at ambient temperatures usually encountered in storage to be ignited or burned unless contaminated with a more volatile product. However, if they are heated to temperatures above their fire points, they can be readily ignited and will support a fast growing hot fire that may be difficult to extinguish. These fuels spread rapidly either on land or water and burn completely, whereas a heavier fuel oil fire may go out of its own accord. A spray of diesel from a line break or a leak may be quite easily ignited by any flame or by contact with an exposed hot exhaust manifold.

c. *Kerosene.* The hazards connected with handling kerosene are similar to those of No. 1 burner fuel oil.

d. *Gasoline.*

1. The atmosphere in any gasoline storage tank consists of a mixture of air and gasoline vapor. An explosive mixture contains roughly not less than 1 percent of gasoline vapor and 99 percent air by volume and not more than 8 percent of gasoline vapor and 92 percent air by volume. In general, the operator must realize that:

(a) All gasolines will give off vapors in copious amounts at any temperature likely to be encountered even in the arctic, and these vapors may form flammable or explosive mixtures with air.

(b) When motor gasolines are stored in tanks or in other closed containers at sea level pressure and the liquid surface temperatures are above 20° F., the vapor above the liquid in the tanks will probably be too rich to support combustion but may burn at gage opening or vent where it becomes diluted with outside air. With liquid surface temperatures between +20° and -70° F. a flammable vapor-air mixture will probably be present in the space in the tank above the liquid level.

(c) Vapors from gasoline spills are extremely dangerous. Under certain conditions gasoline vapor in air will burn freely and without explosion if ignited.

(d) A fire on or near a container of gasoline having a restricted opening may generate enough heat to vaporize the gasoline too rapidly for an explosion to occur inside the container. The vapor thus generated will issue from the opening at a high velocity and burn as it mixes with the air above the opening. However, if the opening is too small the vapor pressure may build up and rupture the container.

(e) Gasoline vapor is heavier than air, and the highest percentage of vapor in the air will be found at lower levels; however, the vapor will gradually spread and become diffused or it may travel along with a current of air for a considerable distance and then be ignited. The flash resulting may travel back to the source of supply and cause an explosion or a fire at some distance from the spark, flame, or other source of ignition.

(f) Due to the difficulty of preventing or avoiding small leaks, there is always danger of vapor ignition from sparks or open flames in areas where gasoline is stored or handled. Accumulation of gasoline vapors must be prevented. This is usually accomplished by proper ventilation, mechanical or natural, and by proper maintenance of storage facilities. Gasoline should never be permitted to enter any drain line or sewer not specifically provided to handle petroleum products in a safe manner.

2. For aviation gasolines the Reid vapor pressure at 100° F. will vary between 5.5 and 7.0 pounds per square inch compared to 6.0 and 14.0 pounds per square inch for motor fuels. Avgas is a flammable liquid but not quite as volatile as regular motor fuel. The same precautions, however, regarding the atmosphere in gasoline tanks apply equally as well to aviation gasoline as to motor fuels, except that a flammable vapor-air mixture will probably be present in an aviation

MIL-HDBK-201B
23 September 1971

gasoline tank, in the space above the liquid fuel, when the liquid surface temperature is between +25° and -40° F.

e. *Jet Fuels.* All grades of jet fuels are flammable liquids but the tendency of these fuels to vaporize varies according to grade. Due to the possible changing of the grades of jet fuel stored in tankage allocated to jet fuel storage or in ship's tanks, the same general precautions should be taken for handling all grades of jet fuels. These general precautions, as regards the flammability of aviation gasolines and the vapor-air mixture in tanks, apply even though jet fuels may not be as volatile as aviation gasolines or motor fuels. Grade JP-4 Reid vapor pressure will vary between 2.0 and 3.0 p. s. i. Although all petroleum fuels are hazardous, and therefore require careful handling and strict observance of safety rules to prevent explosions and fires, Grade JP-4, because of its lower vapor pressure, requires additional precaution in its handling. Grade JP-4 forms explosive vapors at normal storage and handling temperatures. Regardless of this fact, Grade JP-4 is considered no different than any other petroleum fuel in one respect. It still requires a source of ignition to cause it to burn or its vapors to explode. For JP-4 fuels, the static generated in pumping and handling is an inherent source of ignition which is difficult to control. The amount of this charge increases with high linear rate of fuel flow, and the accumulation is greater with the higher specific gravity and wider boiling range jet fuels than with reciprocating engine fuels. The static charge developed tends to leak away rather rapidly in a properly grounded pipeline; however, where there is a free surface, as in a cone-roof tank, the charge tends to accumulate on the surface. In small tanks (up to 15 ft. in diameter) leakage to the walls generally keeps the charge from building up, but in larger tanks a dangerous level may form. Likelihood of an explosion results from the accumulated charge arcing across the liquid surface and igniting the vapors. Usually, the larger the surface area, and the more shallow the tank, the greater the possibility of an accumulated charge. To minimize the generation and accumulation of static electric charge in JP-4 fuel, the following precautions and/or procedures are recom-

mended, when such do not interfere with or hamper the assigned military mission of an activity:

1. The use of overhead fill lines which permit a free fall of product through the air should be minimized, or eliminated if practicable.
2. The entrance of air into fill lines should be minimized or eliminated if practicable.
3. The pumping of mixtures of water and fuel and/or the maintenance of water bottoms in tanks should be minimized, or eliminated if practicable. When it is necessary to use water bottoms, the inlet connection should be kept sufficiently above the water to minimize agitation. Water with entrained air rising through the fuel tends to generate and accumulate a static electric charge. The bursting of bubbles at the surface provides a mechanism for depositing a static charge at the surface of the fuel.
4. The rate of flow (pumping rate) at levels below six feet in a tank should be reduced to below three feet per second, if practicable. It is also considered desirable to reduce the rate of flow when the level in a tank is approaching the top to reduce the risk of flash over to roof members.
5. Where available, floating roof tanks are preferred for Grade JP-4 storage, since such tanks eliminate the vapor space and also provide a ready path for dissipating a static charge. At low levels, however, the same precautions as outlined above should be observed as a floating roof lifts clear of its legs.
6. If practicable, the storage of Grade JP-4 in tanks constructed of concrete or other poor electrical conducting materials should be avoided.
7. All tanks, lines, and associated equipment should be properly grounded or bonded electrically in accordance with approved methods.
8. Even though outside sources of ignition may generally be eliminated effectively by strict adherence to established safety procedures, it should be emphasized that, in the case of

MIL-HDBK-201B

23 September 1971

Grade JP-4, any ignition at gaging hatches, vents (including filler necks on aircraft fuel tanks or cells), will travel into a tank and cause violent combustion (explosion). Grade JP-5 will be found to have a vapor pressure close to 0 p.s.i. Since it does not have as definite a tendency to vaporize as the more volatile grades, the vapor-air mixture in tanks or containers above its liquid surface will probably be too lean to be ignited until the liquid surface reaches a temperature of about 140° F.

7.11 STATIC ELECTRICITY.

a. *The Generation of Static Electricity.* There must be a means of static generation. Examples of these are: separation of the trailing edge of a tire from the roadway upon which it is rolling; steam containing condensate; a static spark in a gap between the pipe and another conductor of a different potential. This is the reason for bonding the pipe to the container into which the product is flowing to keep the pipe and the container in the same potential. Whether a static charge will be generated by a specific turbulence on one product faster than on another has not been determined. It is known, however, that the rate of normal bleed-off is influenced greatly by the degree of conductivity of the product, and the conductivity of the product is increased by its water and impurity content. This is the reason for no experience of static accumulation on the surface of crude product sufficient to cause a vapor explosion in a crude product tank. Bonding or grounding of the piping of the tank, or shell of the tank, will not minimize or effect the production of static electricity charge on the product surface in the tank or lessen the difference in potential of these charges to the shell of the tank or other structures. Although bonding or grounding will prevent the receiving vessel from becoming charged, it serves no purpose in the prevention of the generation of a static charge on the surface of the product, the reduction of the rate of its accumulation, nor prevent the production of an igniting spark from the surface of the product to the shell of the tank or other structure.

b. *The Prevention of Static Electricity.* To reduce the hazard from static electricity in first filling an empty tank which is gas vapor free, only a small stream, one-fourth to one-fifth of maximum rate of flow, shall be allowed to enter the tank. The rate of flow is held down until there is "heel" in the tank or the liquid level is at least 3 to 4 feet above the inlet level. A jet fuel or a gasoline cargo is usually started into a partly filled tank first and the valve on any empty tank is cracked open to permit the liquid level in it to build up gradually. When gasoline is issued to small craft through an open hose nozzle, an electrical bond is required between the nozzle and the tank into which the product is delivered. This is primarily an electrostatic bond and is an absolute requirement. In the prevention of static ignition of jet fuels flowing through pipes the same precautions are to be used in the case of JP-3 and JP-4 as for gasoline. However, in the case of filling a tank truck and other such containers with JP-4, there is a greater possibility of vapors being within the explosive range down in the container. Therefore, more emphasis should be placed on proper bonding between fill spouts and containers. In filling tank vehicles with JP-4, the fill stem should continuously contact the bottom of the compartment, if at all possible.

7.12 PETROLEUM FIRES.

Military fuels, described in Chapter 2, are flammable liquids. Jet fuels and gasolines, the more volatile of these products, will easily vaporize and form combustible atmospheres at all but extreme arctic temperatures. The less volatile fuels, however, are not as easily vaporized but require safe handling as they will burn freely after ignition.

- a. *Types of Fires.* Some types of fires that can conceivably occur and that should be guarded against at a fuel depot are:
1. Brush or grass fires on site, possibly complicated by an oil leak or by burning vapor at a tank vent.
 2. Fire at a tank car rack or at a truck loading or unloading rack.

MIL-HDBK-201B
23 September 1971

3. Fire at a pier or wharf.
 4. Vent or manhole fire at a tank.
 5. Fire at leak or break in a pipeline or dock-hose.
 6. Tank fire, following the partial destruction of a tank roof.
 7. Pumphouse or manifold fire.
 8. Miscellaneous—for example, electrical fire, fire in quarters, or fires as result of enemy action.
- b. *Fire Designations.* Fires at fuel depots are usually designated as either pier fires or shore fires. The primary considerations to be given for these fires are described in the following paragraphs:

1. *Pier Fires.* When a fire occurs at a pier, the first concern of the ship's officers will be to move the ship. The short personnel shall assist in releasing the vessel and immediately shut off any flow of product from the pier lines that may feed the fire. Only after the flow of product has been stopped, can effective extinguishment be attained.

Oil leaks and spills are potential fire-hazards. Close surveillance must be given to the piping system located on or under the pier.

2. *Shore Fires.* Shore fires will normally be of the types listed above. The first step to be taken, when shore fires occur that involve a flow of fuel, such as line breaks or hose failures, is to cut off the supply of product as close to the area involved as practicable.

Fires due to vapor leaks or minor products spills should be extinguished at their start by personnel trained in the proper and immediate use of first aid fire appliances.

7.13 FIRE PREVENTION.

Fire prevention is accomplished by the use of proper construction, the elimination of foreseeable exposure or possible equipment failure as well as the establishment and maintenance of safe operating procedures, proper maintenance of equipment, good housekeeping and the providing of proper first aid fire appliances and fire-extinguishing equipment and

extinguishing agents, sufficient to put out the fires that might occur.

To implement the above, the individual responsible for fire protection should issue instructions, conduct fire drills, and make periodic inspections.

- a. *Fire Inspections.* The periodic fire inspection should not be confused with special inspections conducted by the district fire marshal, the fire protection engineer, or military personnel. The inspections should include but not be limited to the following:
 1. Extinguishers shall be examined to be sure that they are fully charged, properly placed and protected, ready for use, and available in number and type required.
 2. Fire water system including hydrants, standpipes, drains, etc., shall be tested, and adequately protected against freezing and physical injury.
 3. Fire hose and coupling shall be examined to insure that they meet necessary requirements, as to availability, quantity, pressure, and adaptability to the existing fire water system and any auxiliary apparatus that may be called in, in the event of a large fire.
 4. Examine all electrical equipment, grounds, bonds, cathodic protection, and report any conditions noted that might provide a source of ignition.
 5. Note the condition of and adequacy of dikes surrounding tankage, where needed. Diked drains should be closed except during supervised draining.
 6. Pumphouses shall be examined to be sure there are no product leaks, spills, nor evidence of poor housekeeping, and further that there is adequate protection against potential sources of ignition. Proper ventilation is a most important safety measure.
 7. The plant and tank farm shall be inspected to assure that adequate steps have been taken to eliminate potential hazards and that dry grass and weeds have been cut and removed from dikes and tank areas.
 8. Examine areas in the vicinity of boiler plants, heating installations, or other locations where open flames may be used, for possible sources of flammable vapor release.

MIL-HDBK-201B
23 September 1971

9. See that "No Smoking" signs are posted at proper locations and that rules are being observed.
 10. See that all automatic fire doors and windows are maintained in a reliable operating condition and free from obstructions.
 11. See that rules covering permits for hot work including cutting, welding, etc., are observed.
 12. See that pipelines, valves, etc., are marked in accordance with MIL-STD-101 or MIL-STD-161, as applicable.
- b. *Special Instructions.* The fire department should be called upon to provide safety guidance and supervision in all cases when flammable liquids are spilled. It should establish clean-up procedures, establish vapor hazard limits or area boundaries, giving consideration to prevailing wind direction, velocity, and other atmospheric condition.

Safe distances stipulated for operations at military depots should generally exceed those that would apply to commercial installations, especially at advance bases and at airfields, where operations are definitely different and more hazardous than normal commercial operations.

Additional factors of safety are necessary to protect against the more likely occurrences of spills and overflows which constitute the largest source of vapor release to be expected.

- c. *Fire Drills.* The commanding officer visualizing certain circumstances under emergency conditions, shall direct the fire chief to plan his drills to meet such situations.

Fire drills shall be conducted not only to insure that men can handle fire-fighting appliances and equipment, but understand their proper application and use.

In the early training, the conditions assumed for any drill should be fully explained to the fire-fighting crews and to the regular operators prior to the drill. Fire drills and practice fires will be held during daylight hours, until the men are well trained, and shall then be held either by day or night without prior notice to the men.

The regular operators should be included in these drills. They should know the locations of

the proper valves to close, and what pumps are to be shut down to meet the assumed conditions, even though the actual operations may have to be simulated.

7.14 SAFETY IN FUEL HANDLING OPERATIONS.

To produce power, volatile petroleum fuels must vaporize readily and burn rapidly. These necessary characteristics also make those fuels dangerous materials which must be handled with great caution. Five gallons of gasoline have a potential destructive power equivalent to 415 pounds of dynamite. At Military Air Bases or Stations where thousands of gallons of such fuel are handled daily, the potential handling hazards are evident.

Safety instructions with regard to fires and accidents are directed toward two objectives: (1) prevention, and (2) first aid, or extinguishment. The major objective should always be prevention. It is much easier and much better to prevent a fire than to extinguish one. It is much better to prevent an accident than to give first aid to someone injured. In this respect the safe working pressures of valves, flanges, fittings, pipes, and containers must be recognized and operations restricted accordingly.

7.15 FIRE AND EXPLOSION PREVENTION.

As mentioned, volatile petroleum fuels are flammable liquids. They will vaporize at normal atmospheric temperatures, and the vapors will burn readily when ignited. For these fuel vapors to burn or explode, three elements must be present. These are: Fuel, Air or Oxygen, and Heat. All three must be present at the same time and place to produce a fire. If any one of these elements is missing, a fire will not occur. Operating personnel must remember that in any of the operations which they perform, two of the elements, air and fuel, are present. The only other element is heat; and if the fire or sparks occur under such conditions, an explosion or fire will result.

Fuel handling personnel have no control over the air present in most of their operations. With the exception of preventing spills, they have very little control over the generation of flammable vapors. Therefore, chief attention in preventing fires must be given to eliminating all possible sources of ignition. There are many potential ignition sources, but the

MIL-HDBK-201B
23 September 1971

ones most likely to be present during defueling and refueling operations are:

1. Sparks generated by static electricity.
2. Operating aircraft engines.
3. Operating automotive or other internal combustion engines.
4. Arcing of electrical circuits.
5. Open flame.
6. Energy from operating high frequency radar equipment mounted in aircraft.

Static electricity has been the source of ignition for many petroleum fires. One reason for this is that many people do not understand what static electricity is and how it may be generated. One of the most common examples of static electricity occurs when getting out of an automobile. After sliding across the seat, this static charge is discharged by touching a metal part of the automobile. If this experience occurs at night, a spark may be seen the instant the door is touched. It is a spark of this same type which can provide the source of heat to ignite fuel vapors. Static electricity may also be generated by agitation of petroleum liquid, moving machinery, moving vehicles, and by personnel. Protection against these ignition sources is obtained by dissipating static charges through proper connections to the ground before they build up sufficiently to be dangerous or by discharging the static charges before vapors are released into the air. To illustrate the last case, a refueler is grounded and the fill nozzle is touched to the metal vehicle before the refueler tank is opened. Specific procedures for avoiding static electricity ignition sources are listed in another paragraph.

The operation of aircraft engines, automobile engines, or other internal combustion engines can provide sources of ignition. Ignition of vapors may occur through the arcing of distributor points, arcing at spark plugs, hot engines exhaust piping, burning or glowing carbon particles in the exhaust piping, back-firing, and others. Sparks caused by electrical currents is another common source of ignition in fuel handling operations. The heat in this case is a spark, such as may occur when battery terminals are connected or when an electrical switch is operated. Other examples of sparks from electrical currents are: arcing of generator brushes, arcing of welding machine brushes, arcing of brushes or electric motors and tools, and the sparks which occur in short circuits.

Open flames and lights are obvious ignition sources. Similar to this hazard to open flames is that of standard electric light bulbs, and photoflash bulbs. Should any of these bulbs break, the filament would be hot enough to ignite a vapor-air mixture and cause a fire or explosion. Other precautions are:

- a. Personnel should wear non-static producing clothing such as cotton. Nylon, wool, silk and certain plastics should not be worn.
- b. Keep all grounding connections clean, unpainted and in good condition.
- c. Never begin any fuel handling operation until all equipment is properly grounded and bonded.
- d. Do not use a chamois filter for filtering fuels. Chamois filters increase the danger of static electricity.
- e. Never smoke within 100 feet of any refueling operation.
- f. Do not permit or use open fires, matches, cigarette lighters, oil lanterns, or similar open flames within 100 feet of fuel handling operations.
- g. Never perform any repair work during fuel handling operations or while in a hazardous area.
- h. Do not use any flashlights, drop lights, and extension cords, except those approved for use in hazardous locations.
- i. Do not carry "strike anywhere" matches or cigarette lighters in pockets.
- j. Discontinue fuel handling operations at approach of electrical storms.
- k. Be certain that no heaters, welding torches, or blowtorches are being used within 100 feet of fuel handling operations.
- l. Be certain that no internal combustion engines are being operated within 100 feet of fuel handling operations. The only exception to this is engines necessary for the refueling or defueling operations, which are specially equipped with spark arrestors, flame arrestors, and other safety equipment.
- m. Keep gage tape in contact with gage hatch during gaging operations.

MIL-HDBK-201B

23 September 1971

- n. During loading or unloading tank cars, other cars should not be moved into the area. This can be accomplished by the use of approved signal devices or positive mechanical blocking devices installed on the rails.
- o. Keep all equipment and work areas neat, clean, orderly, and in good mechanical condition. This is very important.
- p. Be certain that fire fighting equipment and extinguishers are in good condition and readily available.
- q. Never use gasoline for cleaning floors, automobile parts, clothing, rags, etc.
- r. Never wash hands in fuels.
- s. After using, place all oily waste and rags in self-closing metal containers. Empty containers frequently.
- t. Immediately remove any articles of clothing or shoes which have become soaked with fuels. This should be done in an area free from ignition sources.

7.16 EXTINGUISHING PETROLEUM FIRES.

The providing of fire-protection facilities and the issuing of operational instructions should be the responsibility of the district fire officers.

The following information will serve as a guide for personnel not regularly attached to the fire-fighting department:

- a. *Water and Water Fog.* Water alone can only extinguish an oil fire when applied under favorable circumstances. Solid water streams, water sprays, and water fog all have their proper application. The decision of when, where, and how to apply water should be made by the fire chief.
- b. *Blankets.* Blankets are mainly effective for prompt extinguishment of burning clothing or personnel, and should be reserved for personnel's use. Occasionally, if wet, they can be used to help smother a fire at a vapor leak or at a vent.
- c. *Foam.* Foam, as applied to petroleum fires, is a continuous mass of very small bubbles filled with inert gas or air and held together by surface tension. This foam may be of the

chemical type or of the mechanical (air foam) type.

Foam must be applied in a manner and at a rate that will cause it to collect as a blanket on the surface of a liquid petroleum product with or without the expected fire preceding its application, and spread over the burning surface at a faster rate than the rate at which it can be destroyed by the heat of a fire. The correct rate of application varies with the type of foam, the type of burning product, and the type of foam-discharge outlet. Approximately 1 gallon of water-in-foam for each 10 square feet of liquid surface (or about 1-1/4 inch thickness of chemical or low expansion air foam per minute over the surface) is usually sufficient to fight a gasoline fire in pools or in tanks when the roof is off. Approximately 1 inch thickness of foam per minute should suffice in the case of heavy fuel oils, depending on the length of preburn before application is made. The shorter the time of preburn, the quicker the extinguishing effect of the foam (applies only to fuel oils).

When a high volume flow rate of foam is available, it should be fully utilized by applying it from several points simultaneously. However, each foam stream should be of sufficient size to be effective by itself. It should be so directed as to slide on or be smoothly directed to the surface of the burning liquid, as far as local structure and wind directions will permit.

Prompt, copious, gentle application of foam are most effective.

- d. *First Aid Fire Appliances.* The following general rules should be observed in connection with all fire-extinguishing appliances:
 - 1. Knowledge of their operation and proper application.
 - 2. Proper maintenance, and recharging immediately after use.
 - 3. Examine and test at prescribed intervals.
- e. *Carbon-dioxide Extinguisher.* The carbon-dioxide extinguisher holds liquid carbon dioxide under high pressure. Extinguishers are made with both disk-valves and seat-valves. When the disk-valve type is pierced, the entire contents of the cylinder is released. The seat-valve type having a control valve will permit any desired

MIL-HDBK-201B
23 September 1971

amount of gas to be discharged; when the valve is closed, the remainder of the gas can be saved for future use. The stream should be directed at the base of the flames. This type of extinguisher may be used on fires involving electrical equipment (electric fires).

f. *Soda-acid Extinguisher.* The chemical solution (soda-acid) extinguisher contains a solution of water and sodium bicarbonate and, in a separate bottle, an amount of sulfuric acid. When the chemicals are mixed, on inverting the extinguisher, gas pressure is created within the container which expels a stream of reacted chemical solution (mostly water) through the hose. This type of extinguisher should not be used on electrical fires as fatal shock to user may result.

g. *Dry-chemical Extinguisher.* The dry-chemical extinguisher contains chemically processed bicarbonate of soda in dry powder form, which is discharged by means of stored air or gas pressure contained either inside or outside of the extinguisher shell.

In applying the powder to flammable liquid fires, the stream should be so directed that fire in the near section of the burning area is extinguished first, then gradually moved forward, with the discharge nozzle being moved from side to side. This type of extinguisher may be used on electrical fires.

7.17 SAFETY PRECAUTIONS FOR LOADING JET FUEL AND KEROSENE.

The potential hazards inherent in the handling of jet fuel and kerosene dictate the necessity of special safety precautions in loading these products into tankers and barges and the discharge of product into storage facilities. Preliminary investigation by industry and the Bureau of Mines attributes the special hazards in handling these particular products to the accumulation and discharge of static electricity, which in turn is affected by the rate of flow of distillate, turbulence, and the presence of water in the turbulent distillate. To minimize potential contamination with water, vessel pipelines should be drained and cargo tanks stripped as thoroughly as practicable prior to loading. It is recognized that all traces of

water will not be removed by the stripping operation. Do not exceed loading rates in excess of three feet per second (about 1000 barrels per hour through 12 inch line) through loading lines into tanks until discharge outlet has been covered by a minimum of three feet of product. Thereafter, normal loading rate may be resumed. Under these conditions a T-2 tanker can fully load in not more than 30 hours. The loading rate per second applies to the flow into each tank. The total loading rate shall not exceed the sum of the allowable rates for the individual tanks filled. If there is evidence of turbulence or splashing of the product in a tank after the discharge outlet is covered by the specified three feet of product, the reduced loading rate shall be continued until turbulence ceases. Ullages, water soundings, temperatures, and samples will not be taken on any tank until at least twenty minutes after the tank has been topped-off and flow into the tank has ceased. This restriction will require a change in established inspection procedures. In the past, the initial loading operation has been to pump approximately 2,000 to 5,000 barrels into one tank, preferably aft, then sample immediately. While the sample was being checked, loading of other tanks proceeded. It will be necessary in the future for one tank, preferably aft, to be completely filled and at least twenty (20) minutes elapse prior to sampling. In the meantime, loading of other tanks may proceed at the discretion of the local cognizant inspector. Insure that terminal loading connections are grounded to ship and that this ground is not interrupted by gaskets or other nonconductive barriers.

7.18 SAFETY PRECAUTIONS IN HEATING WASTE OIL.

In heating waste oil to separate water, the oil temperature should be kept below the boiling point of water. If the water should boil, it will create a serious problem of tank overflow. Under some circumstances, even temperatures lower than the boiling point of water may be harmful. Therefore, after a satisfactory reduction in emulsions has been attained, heating should not be carried further. At temperatures over 140°F., the oil may be above its flash point and if contaminated by low boiling point products will give off flammable vapors at much lower temperatures. It should then be treated with the same precautions as gasoline.

MIL-HDBK-201B
23 September 1971

CHAPTER 8. CONSERVATION OF PETROLEUM PRODUCTS

8.1 GENERAL.

Each year an estimated 1,260,000,000 gallons of petroleum products are lost somewhere between the nation's refineries and the ultimate consumer. It has been estimated that of every 100 gallons of crude removed from the ground, only 97 gallons contribute to the nation's well-being; the other three are lost in storing, transporting, refining, and marketing the crude and products. The prevention of stock losses requires constant vigilance by all concerned, adherence to time-tested operating practices, good house-keeping, and acceptance of the principle that it is as important to account for product stocks as it is for cash. When the proper tanks and tank accessories have been chosen and installed, the job of loss control has just begun. Tanks and accessories designed to lower losses will do so only if they are maintained in good physical condition. Any program for reducing evaporation losses must include emphasis on good maintenance. Accuracy in measurement, good maintenance procedures, efficient records and detailed inspections, whenever necessary provide the principal control tools necessary for the achievement of maximum practical product conservation. In this connection, MIL-STD-140 makes it possible to predict with reasonable accuracy the normal loss expectancies for any bulk terminal, and will provide a management tool for assessing the efficiency of a bulk system. It is not possible to assign a dollar value to the savings that will accrue to the owning department as a result of a good conservation program. However, it is obvious that the importance of fuels to the national welfare—especially to the military—is sufficient to warrant consideration of a conservation program of worthwhile magnitude.

8.2 ACCURACY OF PRODUCT MEASUREMENT.

The importance of accurate and careful quantity measurement cannot be overemphasized. The data obtained form the basis for future records and calculations. If the original gaging figures are incorrect, all subsequent records will be affected thereby. Accurate records of receipts and deliveries of all products are as

operating activity. Records are indispensable to stock control, the detection and correction of losses, and the selection of the most efficient operating procedures.

- a. *Calibration.* The necessity for accurate calibration must be recognized. Therefore, whenever practicable, all stationary tanks, tank cars, and tank trucks which are used as liquid quantity measuring containers should be properly calibrated by recognized methods. Once accurate calibration has been established, it is of primary importance that these containers used for storage and transportation of liquid products be maintained in good calibration.
- b. *Gaging.* All terminal and pipeline personnel should be thoroughly indoctrinated as to the methods which are being used to measure receipts, deliveries, and inventories of petroleum products. All gaging equipment should be standardized. Gage tapes and plumb bobs, and gage poles, should be accurate and in good condition. Their accuracy should be determined by periodic checks, made at least once annually against a certified tape.
- c. *Terminal pipelines.* The capacity of pipelines should be established so as to permit accurate measurement of line contents for transportation and inventory purposes. Temperature data, taken at frequent intervals, should also be available for the measurement of these pipeline quantities. Lines should be maintained full of product whenever practicable so as to insure exclusion of water and air. Potential sources of product contamination in lines should be reduced to the absolute minimum.
- d. *Tank Trucks, Tank Cars, and Transports.* Under any system of product control regardless of whether rack and tank truck dispensing meters are used, it is essential that the product not be loaded beyond the prescribed point on the compartment-capacity marker.
- e. *Meters.* The use of meters offers an excellent check, particularly at the larger bulk terminals, for accurate determination of stock deliveries.

MIL-HDBK-201B
23 September 1971

than justified. It cannot be too strongly emphasized that meters will not remain accurately calibrated under continued usage unless they are frequently checked, and unless the selection of meters, the installation, calibration, and general maintenance are carefully planned.

f. *Effect of Marine Transportation Losses.* Although storage losses do not normally include intransit losses, if the product is received by ocean tanker or barge, it is apparent that inaccuracy in tank measurement after receipt might result in an erroneous charge against storage losses. The transportation loss in such cases is based on the difference between 60°F "charge" and 60°F "receipt". If an abnormal variation should occur, the adjusted tanker or barge ullages (these have been adjusted to comprehend calibration inaccuracies) may be used under proper measurement procedures for the purpose of determining which shore tank gallonage has been correctly stated and which has been incorrectly stated. The necessary corrections to "charge" and "receipt" are then made. Further, every effort should be made to insure that, on arrival, all product on the vessel at the unloading point is pumped ashore, and that residual gallonage, if any, is properly accounted for.

g. *Water Bottoms.* Water bottoms should be measured and recorded. Unaccounted for changes in water bottoms should be investigated. A loss in water bottom which results from a leak may be overcome temporarily by the maintenance of sufficient water bottoms to cover the entire tank bottom. Calking the bottom angle may help to reduce or eliminate the leak. The water bottoms must be subtracted from the gross volumetric measurement of a tank to obtain the net volumetric measurement of the product therein. Inasmuch as the water depth may vary between opening and closing gages due to movement of the tank bottom caused by change of head during transfer of product, careful water gaging is essential for accurate accounting of deliveries and receipts.

8.3 INSPECTION AND MAINTENANCE.

Routine inspection, as well as preventive and remedial maintenance, should be initiated and con-

tinued. All equipment should at all times be in good condition. The size and type should be consistent with changing requirements and economic considerations. Differences which arise between loss expectancies and losses measured indicate the need for inspection. Losses which increase from period to period should be carefully scrutinized. Recognized inspection procedures include checking the condition of all operating and measuring facilities and their methods of use. In most plants the facilities which require this inspection include tanks, pumps, valves and fittings on loading racks, and on yard and dock lines, meters, and all routine measuring and gaging equipment, as well as all supplemental accessories and fittings such as vents, flame arresters, roof and shell manholes, gage hatches, valve stems, pump packing, and loading spouts. This inspection takes from a day to a week depending upon the size of the terminal, conditions encountered, and the multiplicity of operations. Inspection should be made by a qualified engineer.

Experience indicates that, for the normal range of petroleum products from residual fuels through aviation gasolines, the losses are a function of the vapor pressure of the product. Thus the net storage losses from non volatile products, such as fuel oil, should be practically negligible.

8.4 LOSS THROUGH THEFT.

Loss through theft may occur at infrequent intervals only, but it does warrant consideration in any study of stock control. Adequate stock control should, for the most part, be provided for by proper equipment, procedures, and records which permit a periodic check by supervisors and auditors of shipments, receipts, deliveries, and inventories. Stock-control systems should be designed to prevent fraudulent operations through such devices as changed or altered invoices, inflated charges for products used in military operations, and erroneous reports of temperatures and gages. For instance, theft may occur when receipts by any means of delivery are erroneously reported, and when no suitable standards have been adopted for in-transit losses. Continued vigilance of the entire system is essential, and all undetermined losses should immediately be investigated.

8.5 RECORDS.

Routine accounting procedures should provide adequate and accurate records of all products involved in receipts or deliveries. The records should

MIL-HDBK-201B
23 September 1971

include periodic summaries, inventories, and delivery reports—their frequency to be determined by local needs. These records are the basis for accurate stock control; they provide a current balance between physical and book inventories, a correlation of terminal stock reports with receipts and deliveries, as well as temperature controls. They also make feasible rechecks by supervisors and auditors. To eliminate the possibility of theft, complete and accurate records of all stock transactions should be maintained.

8.6 CONSERVATION AND STORAGE.

In the construction of a new bulk terminal, or in the erection of new tankage at any bulk terminal, consideration should be given to the possibility of storing non-volatile products for which additional storage is required in old cone-roof gasoline tankage and to erecting new conservation tankage for gasoline storage. This makes possible a conversion to conversation-type tankage for volatile products whenever additional capacity is needed.

If storage of volatile products in cone-roof tanks is necessary, it is desirable that roofs be painted with high reflectivity paint. Self-chalking white paint is considered best for this purpose. Since self-chalking paint renews its surface, it will require more frequent renewal than conventional-type paints. The estimated life of self-chalking white paint on cone-roof tanks varies from two to four years, depending on atmospheric conditions. White paint should also be used on tanks such as balloon breathers, and on wet and dry seal lifters.

In areas where atmospheric smoke, soot, chemicals, etc., present a maintenance problem with respect to self-chalking white paint, other paints such as aluminum may be more appropriate.

With respect to floating-roof tanks the reflectivity of the paint on the roof is not so important; these roofs usually can be painted either aluminum or gray. Scheduling of the delivery of volatile products at the bulk terminal is particularly important, for it can be demonstrated that storage losses sustained on any cone-roof tank are determined by the degree of fill of the tank. Disregarding all other effects of high inventories, it is still a fact that the larger the inventory, the lower the storage loss on a cone-roof tank. Published data indicates that the gallonage loss from breathing sustained by a tank which, on the average, is three-quarters full will be approximately one-half

the loss for the same tank when one-quarter full, other conditions being equal.

Vapor losses may be reduced if the maximum pressure practicable is kept on the stored liquid. This can be accomplished by use of the proper type vent valves and appurtenances, and by avoiding excessive agitation of the liquid surface while the product is being received. Vapor leaks from tanks may be stopped temporarily by means of a satisfactorily tested plastic sealer. Even after the best equipment has been obtained and the finest maintenance or program established, large savings may still be available through a more efficient utilization of tankage. As an example, filling loss takes place when liquid is pumped into the tank and displaces the air-vapor mixture in the vapor space above the liquid. The filling loss will vary in size, depending on the concentration of oil vapor in the mixture thereof with air in the vapor space, and this concentration is determined in part by the way the tank is operated. That is, the longer the interval of time between pumpings, the greater will be the concentration of the oil vapor portions of the mixture. Therefore, shorter periods of standing between pumpings will produce lower concentrations, and accordingly, the oil vapor filling loss will be smaller. This same basic principle applies to the magnitude of "breathing" or standing storage losses, i.e. the longer the standing period and the richer the vapors in hydrocarbon content—up to saturation point—the greater the oil vapor portion of the air-vapor mixture out-breathed daily.

When gasoline stocks are being gaged—especially when the tank contains gasoline vapors under pressure—every precaution should be taken to eliminate, or at least to minimize, losses of vapor which result from the depressuring of the tank. Conservation-type tanks usually are equipped with a pressure-type gaging device, such as a pressure lock. Other applications include gage wells, from which the correct liquid depth may be determined—using the manometer to obtain the correction factor. With a cone-roof tank not equipped with a pressure lock, it is not always possible to gage when the tank is not under pressure. It is generally good practice to do all gaging either in the early morning or in the late afternoon, so that the pressure in the tank will be relatively low at the time of gaging. It is also good practice to reduce the frequency of gasoline stock gaging to the absolute minimum consistent with bookkeeping and accounting requirements.

8.7 EFFECT OF TANK REPAIR ON LOSSES.

Once the magnitude of losses from known sources has been evaluated, the best types of tanks for a new installation may be determined; i.e., the actual savings which may be realized from the repair of existing tanks and from the installation of modern conservation facilities may be evaluated in terms of dollars and cents. Repair of tanks will be considered first, because, in most instances, the use of existing facilities must be continued even though installation of new equipment would be more desirable. However, to guard against uneconomical expenditure for improvements, the economics for each case must be considered separately.

8.8 LOADING RACKS.

Subsurface loading is recommended for volatile products whenever the throughput warrants the installation of the equipment. Savings compared to overhead or splash loading will aggregate 0.10 to 0.15 per cent. When the payout for subsurface-type loading equipment is being calculated, the cost of balanced drop arms vs. replacement equipment should also be investigated.

8.9 EFFECT OF LEAKS.

In any calculation of loss expectancy, the potential loss from drips and leaks should not be overlooked. Whether these constitute a significant part of the terminal's stock losses will depend on their extent and frequency. The following indicates what may be anticipated:

	Gals/year
2 drops per second	1,351
Drops breaking into a steady stream	8,780
1/8 inch stream	95,000

Attention usually is paid to any product which leaks in a steady stream; whereas drops frequently are not considered sufficiently serious to warrant immediate attention. The foregoing data, however, indicate that they may in fact constitute major losses. From these and other fundamental data, the loss expectancy for a terminal may be estimated in gallons and in percent based on throughput.

With the exception of paragraph 8.1, the material in this chapter was taken from Recommended Good Practices for Bulk Liquid-Loss Control published by the American Petroleum Institute.

MIL-HDBK-201B
23 September 1971

APPENDIX A

DEFINITIONS

Acidity—The amount of free acid in a substance.

Additive—Addition agents or additives are used either to impart new properties to an oil, or any other petroleum product or to improve the properties which they already possess. For example, those which when added to gasoline, improve antiknock property.

Antiknock—Resistance to detonation or “pinging” in spark-ignited engines. Typical antiknock materials are benzol, alcohol, and tetraethyllead. The addition of very small amounts of such substances to a gasoline of relatively low octane number has the quality of strongly depressing detonation, recognized by “knocking” in spark-ignition internal combustion engines; that is, it raises the octane number. For gasolines, the principal agent used is tetraethyllead. (See octane number.)

API—American Petroleum Institute.

API gravity—An arbitrary scale established by API to express the gravity or density of liquid petroleum products as single standard to replace the several methods previously used. The measuring scale is calibrated in terms of “API” degrees. It is defined by the following formula:

$$\text{Degree API} = \frac{141.5}{\text{Sp.gr. } 60/60\text{F}} - 131.5$$

Approved lights—Only “explosionproof” lights, motors, switches, or other electrical fixtures approved by the Underwriters Laboratories for class 1, group D hazardous locations are to be employed where concentrations of flammable gases or vapors exist continuously, intermittently, or periodically under normal conditions. Hazardous locations classified as class 1, group D are: atmosphere containing jet fuel JP-4, gasoline, petroleum naphtha, alcohols, acetone, lacquer solvent vapors, and natural gas.

ANSI—American National Standards Institute.

Ash content—The amount of ash or nonvolatile, incombustible material yielded by a measured quantity of organic substances on heating to high temperature. (See ASTM Method D482).

ASME—The American Society of Mechanical Engineers.

ASTM—The American Society for Testing Materials.

Atmospheric pressure—The pressure of air at sea level is exerted equally in all directions. The standard pressure is that under which the mercury barometer stands at 760 mm., or about 30 inches. It is equivalent to about 14.7 p.s.i. and is called one atmosphere of pressure.

Autogenous ignition temperature—The autogenous ignition temperatures of liquid and semiliquid petroleum products are determined by ASTM Method D2155.

No. 791. This is the temperature of a metal alloy bath just adequate to cause ignition of a mixture of petroleum or similar vapor and air when tested in accordance with the carefully prescribed provisions of the method. The autogenous ignition temperature is not a definite physical constant but varies with the nature of the container, concentration of vapor in the air, and other conditions of the test.

Barrel—As the standard unit of measurement of liquids in the petroleum industry, it contains 42 U.S. standard gallons.

Batch—Any quantity of material handled or considered as a unit in processing, computations, etc.

Black oils—Black oils, when referred to in tanker or barge cargo, or in bulk transfers, are those usually classed as boiler fuels or burner fuels. (They do not, of course, include diesel fuels.)

Blend—Any mixture prepared for a special purpose; the products of a refinery are usually blended to suit market requirements.

Blended fuel oil—Fuel oil that is a mixture of two or more types (residual, distillate, or cracked fuel).

Blending—The process of mixing two or more liquids having different properties to obtain a product of intermediate properties. Certain classes of lubricating oils are blended to viscosity, while naphthas may be blended to meet a distillation specification such as end point.

Boiler horsepower—One boiler horsepower is equivalent to the evaporation of 34.5 pounds of water per

MIL-HDBK-201B
23 September 1971

hour from and a temperature of 212°F at atmospheric pressure, and is equivalent to 33,475 B.t.u. per hour (British thermal units per hour). This is now an obsolete term applied only to certain conventional boilers of small capacity.

Boiling—The process by which a liquid is rapidly changed to vapor by the application of heat.

Boiling point—Boiling point is that temperature of a liquid which is not exceeded by the transfer into the liquid of additional heat. The heat so added results in a change of state from liquid to vapor or gas. Boiling point varies with the atmospheric pressure and, under standard conditions at sea level, is 212 degrees Fahrenheit for distilled water.

Boiling range—The range of temperature, usually determined at atmospheric pressure in standard laboratory apparatus, over which the boiling or distillation of an oil commences, proceeds, and finishes.

Bottled gas—Ordinarily, butane or propane or butane-propane mixtures, liquefied or held under pressure in steel "bottles" or cylinders for domestic gas uses.

Bottoms sediment and water (B.S. and W.)—The heavy material which collects in the bottom of storage tanks; usually composed of oil, water, and foreign material now referred to generally as sludge. (See sediment and sludge.)

Breathing—Breathing is the movement of gas (or oil vapor) with air, into and out of the vapor space of a storage tank through vents, vent valves, vent lines or other openings in the tank roof. This may be due to changes in atmospheric temperature, or to alternate heating and cooling of the product stored, or to oil movement into or out of the tank.

B.T.U. (B.t.u.)—Abbreviation for British thermal unit; the average quantity of heat required to raise the temperature of 1 pound of water 1°F. at its maximum density 39.1°F.

Bunker "C" fuel oil—A heavy residual fuel oil used by ships, industry, and for large scale heating installations equivalent to No. 6 Fuel Oil.

Bunker fuel—A fuel oil used on steamships.

Burning oil—An illuminating oil such as kerosene, mineral seal oil, etc., of such gravity and degree of cleanliness that it may be burned through a wick. (See kerosene.)

Burning point—The lowest temperature at which the most volatile components of a petroleum product, held in an open vessel, will continue to burn when ignited by a flame held close to its surface. This temperature determines the degree of safety with which kerosene and other illuminants may be employed. (See also fire point.)

Cetane—A pure paraffin hydrocarbon (C₁₆H₃₄) used as a standard in determining or measuring ignition qualities of diesel fuels.

Cetane number—The ignition quality of a diesel fuel is determined in terms of an arbitrary scale. The determination of cetane number is made with a single cylinder engine of continuously variable compression ratio with suitable loading and accessory equipment and instruments, mounted on a stationary base, and by a method of matching the fuel being tested against mixes of cetane and of alpha-methyl-naphthalene under standard operating conditions. This is described in the test method ASTM D613. A fuel having a cetane number of 60 would have the same ignition quality as a mixture of 60 percent cetane in alpha-methyl-naphthalene.

Clarifier—Any apparatus or device for removing the color or cloudiness of an oil by separating the foreign material through mechanical or chemical means. It may embody the principle of centrifugal action, filtration, simple heating or treatment with acid or alkali, or several of these principles.

Clean products—Clean products refer to those products that are separated in the refining process from fractionating columns as an overhead or side-cut stream or blends of these products, and includes the distillation range from gasoline through diesel fuel.

Cloud point—The temperature at which paraffin wax or other solid substance begins to crystallize out or separate from a petroleum oil solution imparting a cloudy appearance to the oil, when the oil is chilled under definite prescribed conditions. Refer to ASTM Method D2500.

Coefficient of expansion—The amount of INCREASE in length, area or volume of a substance resulting from an increase of 1 degree Fahrenheit in its temperature. Thus, a coefficient may be the linear, area or volume expansion. Within this text expansion of piping would be linear, increase of temperature could cause area expansion of tank shells, and in the case of product expansion would be volumetric.

MIL-HDBK-201B

23 September 1971

***Color stability**—The resistance of oil to discoloration due to light, aging, etc.

***Combustion**—The act or process of burning. Chemically, it is a process of rapid oxidation caused by the union of the oxygen of the air, which is the supporter of combustion, with any material that is capable of oxidation.

Compatibility—(1) When fortifying a petroleum product with an additive, it must not have any harmful effects upon the product to which it is added. Also, it must mix and remain mixed with the product or other additives which may be present. This characteristic is known as compatibility.

(2) Two oils from different sources and of different chemical composition might be reasonably stable individually, might react with each other when mixed, throwing down sludges or becoming unstable. Such oils are said to be incompatible.

Corrosion—The destruction of metal by chemical or electrochemical reaction with its environment.

***Critical velocity**—The rate of flow in a pipe at which streamline flow changes into turbulent flow.

Crude—In a natural state; not altered, refined, or prepared for use by any process, as crude oil or crude petroleum.

Crude petroleum A liquid of geological origin, produced from the earth, consisting predominantly of hydrocarbons, and (usually) relatively small proportions of sulfur, nitrogen, or oxygen derivatives of hydrocarbons. Crude petroleum occasionally contains uncombined or elementary sulfur.

***Diesel fuel**—The fuel used for internal combustion in a diesel engine; usually that fraction which distills over after kerosene; similar to gas oil.

***Diesel fuel additive**—Material added to diesel fuel to improve the ignition quality. Examples are amyl nitrate and ethyl nitrate.

***Gasoline additive**—Materials added in small amounts to gasoline to increase the octane number and thus help prevent knocking. Tetraethyllead is the most common additive used.

Drawoff—A connection on a tank shell (near bottom) or tank bottom, through which water may flow or be drawn from a tank or vessel, or from a sump in the bottom of a tank or vessel.

Drum filler—An apparatus for filling drums automatically to a fixed volume or weight.

Emulsion—See oil emulsion.

End point—The point indicating the end of some operation or at which a certain definite change is observed. In the analysis of liquids such as gasoline, the end point is the temperature at which no more liquid will distill over. (See ASTM Method D86).

Ethyl fluid—See tetraethyllead.

Ethyl gasoline—A motor gasoline containing a very small quantity of added ethyl fluid which has a retarding action on the rate of combustion of the charge, and thus tends to reduce detonation (knocking) in the engine cylinders. (See antiknock.)

***Evaporation**—The conversion of a liquid into a vapor, usually by means of heat.

Evaporation loss—In this text evaporation loss is the loss of a liquid volume or weight due to the free evaporation of the liquid usually in a storage tank at atmospheric pressure. It varies with the temperature, the amount of liquid surface exposed, the temperature of vaporization of the lightest components of the liquid, the velocity of air currents over the surface exposed and the degree of vapor tightness of the tank roof. Since petroleum products are not homogeneous liquids the rate of evaporation is not constant, being greatest at the beginning when the largest percentage of light volatile hydrocarbons are present and slowest when evaporation has proceeded so far that only heavy residues are left.

***Evaporation test**—A test applied to volatile petroleum products to determine the completeness or rapidity of evaporation.

Explosimeter—See gas detector.

Explosive limits—Mixtures of petroleum vapor and air within certain limits can be ignited. The explosive limits are defined as limits of percentage composition of mixtures of gases and air within which an explosion takes place when the mixture is ignited. The lower limit of flammability corresponds to the minimum amount of combustible gas and the upper limit to the maximum amount of combustible gas, within which the mixture is flammable. For gasoline vapors in air, these limits are approximately 1 percent and 6 percent by volume, respectively. Other vapors may have different limits. Combustible gas or vapor indicators are designed to indicate the percentage of the

MIL-HDBK-201B
23 September 1971

lower, flammable limit of vapors present in the atmosphere.

Filtration—A mechanical process for removing suspended material from a liquid by passing it through a porous material.

Final boiling point—See end point.

**Fire point*—The lowest temperature at which, under specified conditions in a standardized apparatus, a petroleum product vaporizes sufficiently rapidly to form above its surface an air-vapor mixture which burns continuously when ignited by a small flame.

Flammable—Capable of being easily set on fire or ignited; combustible vapors under ordinary conditions. In accordance with the modern trend in usage, the earlier used term "inflammable," because of possible misinterpretation of the prefix "in" as a negative, has been replaced by "flammable" without change of meaning.

Flash point—The lowest temperature expressed in degrees Fahrenheit in U.S. Specifications at which vapors arising from a petroleum product will ignite momentarily (that is flash) on application of a flame under specified conditions.

**Fuel oil*—Any liquid or liquefiable petroleum product burned for the generation of heat in a furnace or firebox, or for the generation of power in an engine, exclusive of oils with a flash point below 100°F. (38°C.) (Tag-closed tester), and oils burned in cotton or wool wick burners. (See kinds of fuel oils.)

Kinds of fuel oils—Fuel oils in common use fall into four classes:

- (1) Residual fuel oil, which is a topped crude petroleum or viscous residuum obtained in refinery operations.
- (2) Distillate fuel oil which is a distillate derived from crude petroleum.
- (3) Crude petroleum and weathered petroleum of relatively low commercial value.
- (4) Blended fuel which is a mixture of two or more of the three preceding classes. (See ASTM D396.)

Gallon—A unit measure of volume. A U.S. gallon contains 231 cubic inches or 3.785 liters. It is equal to 0.83268 times the Imperial gallon, which contains 277.42 cubic inches. One U.S. gallon of water or

liquid of 10° API gravity weighs 8.328 pounds at 60°F.

Gas detector—An instrument for determining the explosibility of a gas-air mixture. It is used as a safety device where oil is stored or handled. It is also known as an explosimeter and as a combustible gas or vapor indicator. (See explosive limits.)

**Gasoline*—A refined petroleum naphtha which, by its composition, is suitable for use as a carburant in internal-combustion engines.

Gauge table—Tables prepared to show the contents of a tank for each 1/8 or 1/16 inch of oil contained in the tank. After the tank has been gaged with a steel tape or pole and the height of the liquid determined, the contents of the tank can be found by reference to these tables. The tables are compiled either through an ordinary calibration of the tank, or by a mathematical computation of the cylindrical volume for each inch of altitude, deducting the volume occupied by "deadwood." Tables of temperature corrections are often made available for use in reducing the measured contents of the tank to a standard volume at 60° F. These volume calculation and correction tables are identified in ASTM D1250. These methods together with extensive supplementary information are issued in a separate publication entitled "ASTM Manual on Measurement and Sampling of Petroleum and Petroleum Products."

Gravity—The ratio of the weight of any specified volume of a liquid or solid to the weight of an equal volume of distilled water at 60° F.

**Gum (general)*—(1) In the petroleum industry the term is descriptive of resin-like insoluble deposits formed during the deterioration of petroleum and its products, particularly gasoline.

**Gum test*—A test to show the amount of residue left after evaporating a definite amount of gasoline.

Horsepower (mechanical)—Power is the rate of doing work. One mechanical horsepower equals 33,000 ft.-lbs. per minute or 550 ft.-lbs. per second.

**Hydrometer*—A graduated instrument for determining the gravity of liquids, usually a hollow glass instrument, weighted at one end so as to float upright. On immersion in liquid, it sinks lower as the liquid is lighter, since the buoyant force is thus less. Some hydrometers are marked to read percentages of concentration or other properties which may be

MIL-HDBK-201B
23 September 1971

calculated directly from the gravity. The instruments used in measuring petroleum products usually read API degrees or specific gravity directly. (See ASTM D287).

Hydrostatic head—That portion of the indicated pressure at a point in a piping system or pipeline, which is due to the super-imposed height of the liquid head acting at that point.

Ignition point—The point on a temperature scale at which a substance may be ignited to produce combustion.

Ignition quality—The ability of a fuel to ignite upon injection into the engine cylinder.

Ignition temperature—See autogenous ignition temperature.

Ignition quality of diesel fuel—See cetane number.

Inflammable—See flammable.

Inflammable liquids—See flammable liquids.

Inhibitor—A substance, the presence of which in small amounts in a petroleum product prevents or retards undesirable chemical changes taking place in the product, or the condition of the equipment in which it is used.

Initial boiling point—The initial boiling point is defined as the recorded temperature when the first drop of liquid falls from the outlet of the laboratory condenser used in this test. (See ASTM Method D86).

Innage—Converse of outage; refers either to volume of liquid or the measured height of liquid in a tank or container, as measured from the bottom of the tank to the surface of the liquid.

**Kerosene*—A refined petroleum distillate having a flash point not below 73° F. (23° C.)¹ as determined by the Abel tester (which is approximately equivalent to 73° F. (23° C.) as determined by ASTM D56, and suitable for use as an illuminant when burned in a wick lamp.

**Kinematic viscosity*—The kinematic viscosity is defined as the absolute viscosity divided by the density at the temperature of the viscosity measurement. The metric units of kinematic viscosity are the stoke and centistoke, which correspond to the poise and centipoise of absolute viscosity. (See absolute viscosity.)

¹ Minimum flash point of Kerosene is 115° F. as given in Specification VV-K-211. (See Sec. IV of Ch. 2).

Knock rating—See octane number.

Lead susceptibility—The ability of the gasoline to respond to the addition of tetraethyllead as reflected in the increase in antiknock value (octane number) per increment of lead added.

Lovibond tintometer—An instrument used for determining the color of refined petroleum oils, reading in Lovibond "color" numbers.

NPRA—National Petroleum Refiners Association.

**Octane number*—A term numerically indicating the relative antiknock value of a gasoline. It is based upon a comparison with the reference fuels iso-octane (100 octane number) and normal heptane (zero octane number). The octane number of an unknown fuel is the volume percent of iso-octane with normal heptane which matches the unknown fuel in knocking tendencies under a specified set of conditions.

The methods for determining the knock characteristics of fuels together with extensive supplementary information are issued in a separate publication entitled "ASTM Manual of Engine Test Methods for Rating Fuels." This includes D614, D909, D2700 and D2699.

**Oil emulsion*—A mixture of water and oil in which the oil is more or less permanently suspended in the water in the form of very small droplets, or vice versa.

Outage—The difference between the full or the rated capacity and the actual contents of a barrel, drum, tank, or tank car. The vertical distance between the surface of the liquid in a barrel, drum, tank, or tank car and the top of the container or the reference mark at the top of the tank or in the dome of the tank car. It is important that some such appreciable difference always exist in order to allow a free space for the expansion of the contents in case of rise in temperature. Outage gages or ullages are normally taken on ships' tanks. (See gaging operations.)

**Pensky-Martens closed tester*—Apparatus used for the determination of the flash point of fuel oils, cutback asphalts, and other viscous materials and suspensions of solids.

Petroleum—See crude and crude petroleum.

pH Value—pH value is a negative exponent of the positive hydrogen ion concentration of a liquid; for instance $+H^{-n} = 1/H^n$. When the exponent n is equal to 7 the solution is neutral. Values +H greater than 7

indicate increasing values of alkalinity, and values less than 7 indicate increasing values of acidity.

Pipeline—In this handbook, it is a line of pipe with pumping machinery and other apparatus used for transportation of petroleum products.

***Poise**—A unit used to express absolute viscosity. Is equal to one dyne-second per square centimeter. (See absolute viscosity, and viscosity.)

POL—Petroleum Oil Lubricants.

Pour point—The lowest temperature at which a petroleum oil will pour or flow, when it is chilled, without disturbance under specified conditions. See ASTM D97. The pour point is taken as the temperature 5° F above the solid point, that is where solidification begins.

Pour test—The chilling of a liquid under specified conditions to determine the pour point. Observations are generally made over 5° F. intervals of temperature.

Pressure drop—The decrease of pressure in pounds per square inch, or head in feet, of a fluid flowing in a piping system from one point to another point downstream from the first point. Pressure drop may be caused by friction, increase of elevation or increase of velocity.

Pump, centrifugal (volute type)—Consists of one or more impellers mounted on a rapidly rotating shaft. The liquid enters the impeller at the center, or "eye", and is impelled outward from the center by centrifugal force at high velocity into the volute of the pump casing. The function of the volute is to catch the impeller discharge and convert peripheral (tangential) velocity head into pressure head while conducting the liquid at a reducing rate of flow to the discharge nozzle of the pump casing.

Pump, duplex—A reciprocating pump which has two liquid cylinders. Duplex pumps have a more steady discharge flow and pressure than do simplex pumps.

Pump, multistage—A centrifugal pump which has two or more impellers mounted on the same shaft. The discharge from one impeller is conducted to the suction eye of the next impeller, etc. Petroleum products pumps with up to 14 stages and developing over 3,000 p.s.i. discharge pressure are in use.

Pump, power—A reciprocating pump in which the liquid pistons are driven by other means than rods

connected to direct acting steam pistons, usually by a crank shaft driven through gears or speed reducer by an automotive engine or electric motor.

Pump, reciprocating—Consist of one or more cylinders into which liquid is sucked on the intake stroke of a piston, and discharged on the discharge stroke. It is usually driven by a direct-connected steam piston, although installations employing belt, gear, or chain drive by steam turbine, diesel engine, or electric motor may be used. It may commonly be of simplex, duplex, or triplex (1-, 2-, or 3-pump cylinders) and be single acting (1 working stroke per revolution utilizing 1 side of piston) or double-acting (2 working strokes per revolution utilizing both sides of piston). This pump is essentially a low-speed, low-capacity pump, and is best suited to the handling of small quantities of viscous liquids at high heads and variable discharge pressures.

Pump, rotary—A positive-displacement pump used mainly to pump liquids that are either too viscous (or too volatile) to readily pick up from a lower level with a centrifugal pump. There are many types of rotary pump designs, the most common being the gear-type and lobe-type, in which two gears or lobes mesh and therefore rotate in opposite directions, with very close clearances between the rubbing surfaces and closely fitting the casing. The liquid is trapped between the gear teeth or lobes and the casing, and is carried around to the discharge side of the pump. The close meshing and minimum clearances prevent the liquid from bypassing to the suction side.

Pump, simplex—A reciprocating pump that has one liquid cylinder on a direct rod drive, or driven by a single crank or rocker arm.

Pump booster—When the pressure of fluid flowing in a pipe is nearly expended and approaches zero, a booster pump is used to impart additional energy to the fluid. The energy thus imparted can be used to increase flow rate.

***Redwood viscosimeter**—A viscosimeter used for viscosity determinations on petroleum products in the United Kingdom.

Reid vapor pressure (RVP)—One of the important specifications for gasolines. It is a measure of the vapor pressure of a sample at 100° F., and the test is commonly made in a bomb. The results are reported in pounds per square inch (p.s.i.).

SAE—Society of Automotive Engineers (American).

MIL-HDBK-201B
23 September 1971

Saybolt colorimeter or chromometer—An instrument used to determine the color of refined oils (gasolines, naphtha, kerosene, and some lubricating oils). (See ASTM Method D156).

Saybolt color—A scale for the determination of the color of gasoline and burning oils.

Scraper—A scraper with self-adjusting blades, which is inserted into a pipeline to help clean accumulations from the wall of the pipe. It is carried forward by the fluid pressure, and rotates through the action of the oil on flowing past the curved blades.

**Seconds (S.S.U.) (as applied to Saybolt viscosity)*—The number of seconds required for a given quantity of oil (60 cc.) to flow through a standard orifice at specified temperatures (usually 100°, 130°, and 210° F.).

**Sediment*—Any material other than water which separates by gravity below the liquid in a tank. It generally consists of sand, dirt, or some emulsion. (See B.S.&W., and sludge.)

Stop tanks—Tanks regularly containing products which are not up to quality, or those products which are to be treated or degraded and transferred to selected tanks.

Sludge (general)—Any waste product which collects at the bottom of a storage tank containing crude oil, fuel oils, or other petroleum products. Such sludge usually contains water. (See B.S.&W.)

Specific gravity—The ratio of the weight of a volume of solid or liquid to the weight of an equal volume of pure, distilled water, with both media at 60° F. In the case of gases, the ratio is referred to hydrogen or air. In practice, specific gravity is usually determined by means of a hydrometer.

**Specific heat*—The ratio of the quantity of heat required to raise the temperature of a body 1° to that required to raise an equal mass of water 1°.

Specification—Prescribed limits of control tests used to maintain uniformity of a specific product.

Stoke (centistoke)—A unit of kinematic viscosity in centimeter-gram-second (c.g.s.) units. A customary unit is the centistoke = (stoke/100).

Strapping a tank or strappings—Strapping is a trade expression which is used to indicate that the calibration of a tank is derived by pertinent measurements and calculation of its volume as differing from

liquid calibration. It is also used to indicate circumferential measurements of a tank as in the case of calibration of a tank by the measurement method.

**Tag (or Tagliabue) closed tester*—An apparatus used for the determination of the flash point of all mobile liquids flashing below 175° F. with the exception of fuel oils.

**Thief*—A device which permits taking a product sample from a storage tank from a definite predetermined location in the body of the liquid to be sampled. It consists of a metal box with a heavy lid which opens very slowly on submerging the box in the liquid. The box is quickly lowered to a point in the tank from which the sample is to be taken and is slowly filled in this location.

Thieving a tank—Taking product samples from any part of a tank by means of the mechanical device known as a "thief".

**Vapor*—Gaseous substances which can be at least partially condensed by moderate cooling or compression.

**Vapor pressure*—The pressure exerted by the vapors released from any material at a given temperature, when enclosed in a vaportight container. (See Reid vapor pressure.)

**Viscosity*—The measure of the internal friction or the resistivity to flow of a liquid. In measuring viscosities of petroleum products, the values of the viscosity are usually expressed as the number of seconds in time required for a certain volume of the oil to pass through a standard orifice under specified experimental conditions.

**Viscosity, absolute*—The force which will move 1 sq. cm. of plane surface with a speed of 1 cm. per sec. relative to another parallel plane surface from which it is separated by a layer of the liquid 1 cm. thick. This viscosity is expressed in dynes per square centimeter, its unit being the poise, which is equal to 1 dyne-second per square centimeter. A unit of one-hundredth of a poise, designated as a centipoise, is of more convenient magnitude, and is commonly used.

**Viscosity, kinematic*—The kinematic viscosity is defined as the absolute viscosity divided by the density at the temperature of the viscosity measurement. The metric units of kinematic viscosity are the stoke and centistoke, which correspond to the poise and centipoise of absolute viscosity.

MIL-HDBK-201B
23 September 1971

**Viscosity, Saybolt Furol*—A viscosity test similar in nature to the Saybolt Universal viscosity test, but one more appropriate for testing high-viscosity oils. Certain transmission and gear oils and heavy fuel oils are rated by this method. The results obtained are approximately one-tenth the viscosity which would be shown by the Saybolt Universal method.

**Viscosity, Saybolt, Universal*—The time, in seconds, for 60 ml of fluid to flow through a capillary tube in a Saybolt viscosimeter under specified conditions.

Volatile—Readily vaporizable.

Volatility—The degree to which fuels vaporize (form vapor). The ease with which a liquid is converted into a vaporous state.

Ullage—The amount that a tank, container, or vessel lacks of being full; a term generally used in connection with ship's tanks. (See outage.)

Water drawoff—See Drawoff.

Water, free—All water present in the fuel which has not been dissolved by the fuel is considered "free" water. This water should be separated from fuel by ground servicing equipment.

Water, entrained—"Free" water which is suspended throughout a fuel sample and has not settled to the bottom of the container is considered "entrained" water.

Water, dissolved—All fuel will contain water in solution but the amount will vary considerably as the temperature of the fuel varies. A rule-of-thumb estimate of the amount can be made by stating that the water-saturation value of the fuel is equal to PPM (parts per million) by volume to the fuel temperature in degrees Fahrenheit. The percent of dissolved water can only be determined by a laboratory test such as the Karl Fischer analysis. This water cannot be separated from fuel by filtration or by mechanical means.

**Water white*—A grade of color in oil, defined as plus 21 in the scale of the Saybolt chromometer.

**Water white distillate*—A kerosene cut, or refined oil cut, coming from crude stills, before this distillate is treated or rerun.

*Definitions marked with an asterisk are either taken from or exactly duplicate those included in the American Petroleum Institute publication entitled "Glossary of Terms Used in Refining."

MIL-HDBK-201B
23 September 1971

APPENDIX B
PUBLICATIONS
PERTAINING TO
PETROLEUM AND PETROLEUM OPERATIONS

ARMY Publications Pertaining to Receipt, Storage and Distribution of Bulk Petroleum Products

a. ARMY REGULATIONS:

AR 11-21	Environmental Pollution Abatement
AR 700-91	Operating Procedures for Bulk Petroleum and Coal Products
AR 700-91-2	Quality Surveillance of Petroleum Products
AR 700-9100-3	Logistics (General) Quality Surveillance and Test Facilities for Petroleum Products in Overseas Areas
AR 701-9100-1	Petroleum Supply System (Logistic Responsibility)
AR 703-1	Petroleum Supply and Management Activities
AR 703-2	Bulk Petroleum Terminal Report
AR 754-9130-1	Utilization of Automotive Gasolines

b. TECHNICAL MANUALS:

TM 5-343	Military Petroleum Pipeline Systems
5-678	Repairs and Utilities - Petroleum Oil and Lubricants (POL)
10-1101	Petroleum Handling Operations
10-1105	Inspecting and Testing Petroleum Products
10-1109	Organizational Maintenance: Military Petroleum Pipelines, Tanks and Related Equipment
10-1113	Petroleum Tank Vehicle Operations
10-1118	Petroleum Terminal and Pipeline Operations
10-1158	Petroleum Testing Kit
10-1160	Petroleum Laboratory, Mobile, Semitrailer Mounted
10-1161	Petroleum Base Laboratory, Furniture and Equipment
10-1163	ASTM Manual for Rating Aviation Fuels by Supercharge and Aviation Methods
10-1164	ASTM Manual for Rating Motor Fuels by Motor and Research Methods
10-1165	Significance of ASTM Tests for Petroleum Products
10-1166	Book of ASTM Standards - Part 17
38-750	The Army Maintenance Management System
55-1930-202-12	Operator and Organizational Maintenance Manual: Barge, Deck or Liquid Cargo Non-propelled Steel, 578-Ton or 4160-Bbl, 120 Feet Design 231B
743-200	Storage and Materials Handling

c. FIELD MANUALS:

10-67	Petroleum Supply in a Theater of Operations
101-10-1	Staff Officers Field Manual: Organizational, Technical and Logistical Data - Unclassified

d. OTHERS:

C-9100-IL	Federal Supply Catalog. Identification List. Fuels, Lubricants, Oils and Waxes
TB 34-9-46	Pump Centrifugal, Gasoline Dispensing, Portable Gasoline - Engine Driven (Capacity 50 GPM 1000 Ft Head)

MIL-HDBK-201B
23 September 1971

TB 34-9-45	Pump Gasoline Dispensing, Portable, Gasoline Engine Driven, Capacity 225 GPM
TB 34-9-50	Petroleum Testing Kit
TB 34-9-60	Bulk Storage Tanks, Bolted, Steel, Semi-permanent 250, 500, 1000, 3000 and 10,000 Bbl Capacity
TB 55-9150-200-25	Engine and Transmission Oils, Fuels and Additives for Army Aircraft

AIR FORCE Publications Pertaining to Fuel, Oil Storage and Handling

a. TECHNICAL ORDERS:

TO 37-1-1	Inspection Record for Permanently Installed Base Petroleum Systems
TO 36-1-3	Painting and Marking of USAF Vehicles, Ground Servicing and Motorized Equipment
TO 00-25-212	Dissipation of Accumulated Static Electricity
TO 36A9-3-8-1	Operation and Service Instructions, Type F-6 Fuel Servicing Semi-Trailer
TO 36Y31-1-1	Removal of Rust and Sediment from Fuel and Oil Servicing Truck and Trailer Tanks and the Application of Coatings Interior, Fuel and Oil Resistant
TO 37A-1-101	Operation and Service Instructions Fuel and Oil Handling Equipment and Mechanical Fuel Segregators
TO 37A10-1-101	Operation and Maintenance Instructions Oil Storage and Dispensing Systems
TO 37A14-1-101	Operation and Maintenance of Automotive Fuel Storage and Dispensing Systems, Permanently Installed
TO 42B-1-1	Quality Control of Fuels and Lubricants
TO 42B-1-2	Container Storage of Gasoline, Jet Fuel and Oils
TO 42B-1-7	General Use of Aircraft and Electronic Lubricants
TO 42B1-1-15	NATO Symbols for the Identification of Fuels and Lubricants Used by the Armed Forces of the United States
TO 42B1-1-1	Fuels for Use in All Piston and Turbine Aerospace Ground Equipment and USAF General Purpose Vehicles
TO 42B1-1-14	Fuels for USAF Aircraft
TO 42B1-1-2	Aircraft Fuel Volume Correction Tables
TO 36A12-13-8-1	Aircraft Refueling Tank Truck (R-2)
TO 42B2-1-1	Use and Guides of Aircraft Engine Lubricating Oils

b. REGULATIONS:

AFR 91-13	Permanently Installed Storage and Dispensing Facilities for Petroleum and Unconventional Fuels
-----------	--

c. MANUALS:

AFM 177-108	Paying and Collecting Transactions at Base Level
AFM 127-101	Accident Prevention Handbook for Air Force
AFM 67-1	USAF Supply Manual
AFM 77-1	Joint Procedures for Management of Administrative Use Motor Vehicles
AFM 85-16	Maintenance of Permanently Installed Petroleum Storage and Dispensing Systems for Petroleum and Unconventional Fuels
AFM 177-102	Commercial Transactions at Base Level
AFM 177-130	Systems, Transactions and Reporting at Major and Intermediate Command Level
AFMLCM 85-1	Operation of USAF Bulk Petroleum Storage Depots

MIL-HDBK-201B
23 September 1971

NAVY Publications Pertaining to Fuel Oil and Lubricating Oil Storage and Handling

OPNAV INSTR. 4630.7A	Policy of Navy Department with Regard to Traffic Airlifted by the Fleet Tactical Support Squadrons
NAVMAT P-5100	Department of Navy Safety Precautions for Shore Activities
NAVFAC DM-22	Design Manual Liquid Fueling Dispensing Facilities
NAVAIR INSTR. 10340.3	Maintaining Quality and Limiting Contamination of Aircraft Fuels
NAVAIR INSTR. 10341.1	Utilization of Aircraft Engine Fuels
BUAER 10345.7	Safety Precautions Application to Gasoline and Jet Fuel Tank Vehicles Undergoing Repairs and Storage
NAVAIR INSTR. 10300.1	Aviation Fuels, Lubricants and Specialty Products; North Atlantic Treaty Organization Standardization of
NAVAER 00-80T-74	Fuel Contamination, Information Manual
NAVAIR 10350.1	Lubricating Oils, Utilization of
NAVAER 06-5-502	Handbook for Aircraft Refueling Guidance for fuel handling personnel. Covers the problem in theory and practice from fuel farm to aircraft
COMSTS INSTR. 3121.3C	Tanker Operating Instructions (TANKOPINS)
NAVPERs 10883A	Fundamentals of Petroleum
NAVSHIPS 250-332	Familiarization and Operations Manual Saddle Tank Hydraulic Gasoline System of Aircraft. Gasoline storage tanks, gasoline pumping and distri- bution system, salt water supply and drainage system, inert gas and CO ₂ protective system; pump room, safety measures
NAVSHIPS 0900-016-0010	Manual for Cargo Tank Cleaning
NAVSHIPS	Familiarization and Operations Manual - Hydraulic Gasoline System for Aircraft Carriers. Describes representative items of commercial equip- ment in their relation to operation of the gasoline handling system.
NWP Change 3 (Limited Distribution)	Replenishment at Sea
TP-PL-17	Advance Base Fuel Storage
NAVDOCKS P-342	Fuel Storage Tank Cleaning at the Shore Establishment (Finished Product Tanks)
BUSANDA INSTR. 5450.29	Mission of Fuels Supply Office
NAVSANDA Publication I	Bureau of Supplies and Accounts Manual, Volume III, Supply Afloat Fuel identification and classification, procurement, purchasing regula- tions, receipts, expenditures inventory control, storage and handling.
NAVSANDA Publication I	Bureau of Supplies and Accounts Manual, Volume III, Ships Operating Indirectly Under the General Supply System.
NAVFUELSUPO INST. 4400.1A	Bulk Lubricating Oil, Handling, Storing of.
NAVFUELSUPO INST. 10341.1	Handling Requirements and Safety Characteristics of JP-5 Fuel

MIL-HDBK-201B
23 September 1971

DEFENSE SUPPLY AGENCY Publications

DFSC	Reference List of Specifications and Standards for Petroleum and Related Products
DSAM 4155.1	Petroleum Procurement Inspection Manual

FEDERAL AND MILITARY Standards, Handbooks Pertaining to Petroleum Products.

a. FEDERAL:

Federal Test Method - Lubricants, Liquid Fuels, and Related Products, Methods of Testing Standard No. 791

b. MILITARY:

MIL-STD-101	Color Code for Pipelines and for Compressed-Gas Cylinders
MIL-STD-140	Procedure for Determining Normal Loss Expectancies for Liquid Petroleum Products
MIL-STD-161	Identification Methods for Bulk Petroleum Products Systems
MIL-STD-290	Packaging, Packing and Marking of Petroleum and Related Products
MIL-HDBK-200	Quality Surveillance Handbook for Fuels, Lubricants and Related Products
MIL-HDBK-210	Planning Factors Handbook

INDUSTRY Publications

API Bulletin RP 2000	Guide for Venting Atmospheric and Low Pressure Storage Tanks
API Bulletin 1501	The Filtration of Aviation Fuels
API Bulletin 1623	Recommended Good Practices for Water Removal from Tanks in Terminals and Depots
API Accident-Prevention Manual No. 13	Cleaning Mobile Tanks Used for Transportation of Flammable Liquids (Section B—Tank Cars)
API Accident-Prevention Manual No. 8	Safe Practices in Bulk Plant Operations
API Bulletin RP 2003	Protection Against Ignitions Arising Out of Static, Lightning, and Stray Currents
API Bulletin 1502	The Installation of Fixed Fuel Handling Equipment at Airports
API Bulletin 1503	The Storage and Handling of Jet Fuels at Airports
API Bulletin 1505	Airport Fueling Systems - Planning Criteria
API Bulletin 1523	Fueling Turbine-Powered Aircraft
API STD 1101	Measurement of Petroleum Liquid Hydrocarbon by Positive Displacement Meters

Copies of the above publications may be purchased from the American Petroleum Institute, 1801 K Street, N.W., Washington, D.C. 20006.

ASTM D1250 and IP:200 Table 5	Reduction of Observed API Gravity at 60°F (American Edition)
ASTM D1250 and IP:200 Table 7	Reduction of Volume at 60°F. Against API Gravity at 60°F (Abridged Table) (American Edition)
ASTM Manual D270	Sampling of Petroleum and Petroleum Products
ASTM D1250 and IP:200	Pounds per US Gallon at 60°F and US Gallons at 60°F per Pound Against Specific Gravity at 60°F and Table 26—Pounds per US Gallon at 60°F and US Gallons at 60°F per Pound Against Specific Gravity 60/60°F (American Edition)

Copies of the above tables may be purchased from the American Society for Testing Materials, 1916 Race Street, Philadelphia, Pennsylvania 19103.

MIL-HDBK-201B
23 September 1971

MILITARY and FEDERAL Specifications for Petroleum and Petroleum Products Normally Handled in Bulk.

MILITARY:

MIL-F-859	Fuel Oil, Burner
MIL-F-16884	Fuel Oil, Diesel Marine
MIL-F-24397 (SHIPS)	Fuel, Navy Distillate
MIL-G-3056	Gasoline, Automotive, Combat
MIL-G-5572	Gasoline, Aviation, Grades 80/87, 100/130, 115/145
MIL-J-25656(USAF)	Jet Fuel, JP-6
MIL-T-5624	Turbine Fuel, Aviation, Grades JP-4 and JP-5

FEDERAL:

VV-F-800	Fuel Oil, Diesel
VV-F-815	Fuel Oil, Burner
VV-G-76	Gasoline, Automotive
VV-K-211	Kerosene

Custodians:

Army - ME
Navy - SA
Air Force - PREEU

Preparing Activity

DSA - PS

Review Activities:

Army - CE
Air Force - 23, 68

APPENDIX C

TANK CAPACITY DIAGRAM FOR APPROXIMATE VALUES

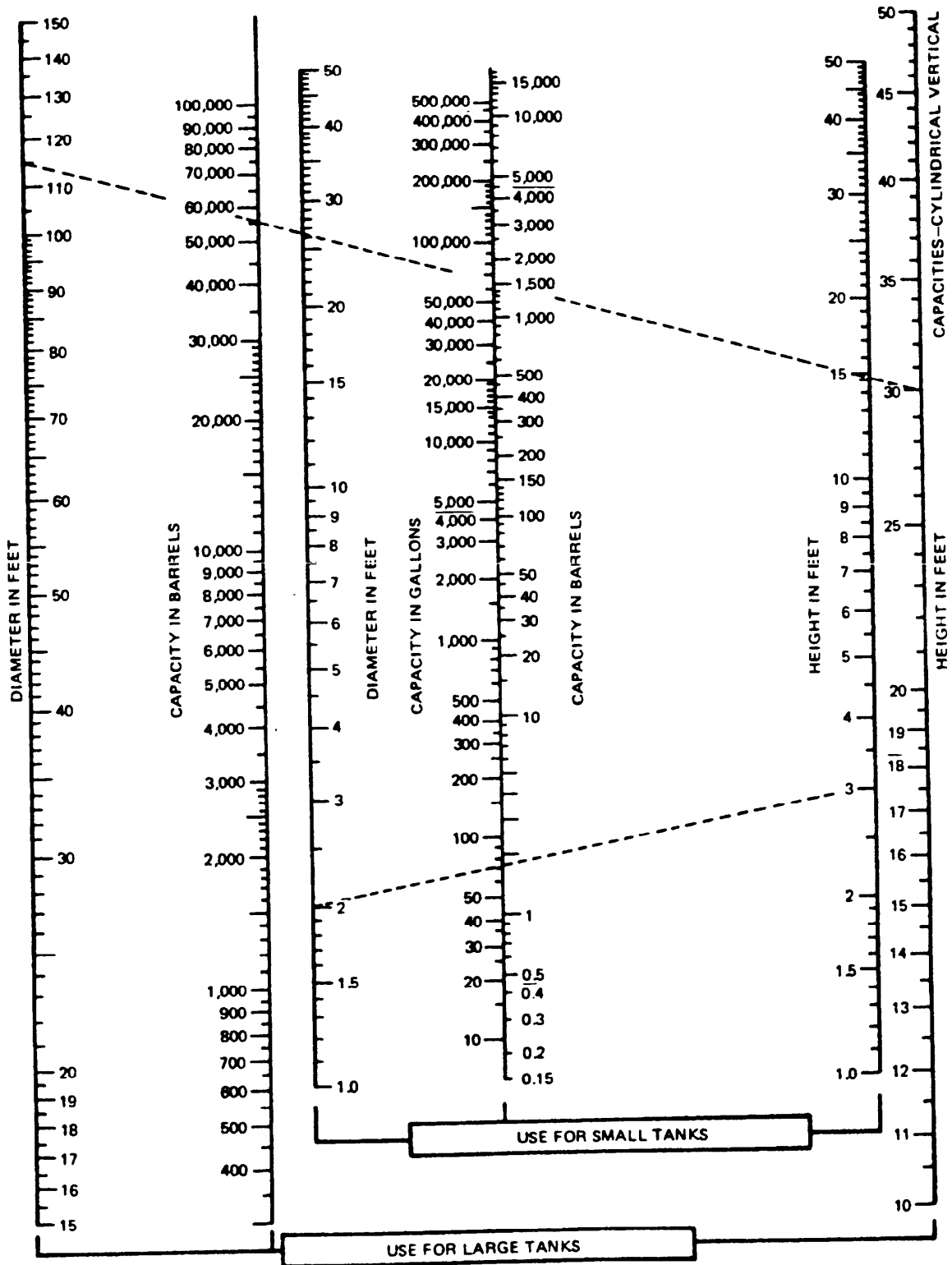

MIL-HDBK-201B
23 September 1971

DIMENSIONS		CAPACITY		DIMENSIONS		CAPACITY		DIMENSIONS		CAPACITY	
D (ft)	H (ft)	BBL	1000 GAL	D (ft)	H (ft)	BBL	1000 GAL	D (ft)	H (ft)	BBL	1000 GAL
15	12	378	16	50	12	4.200	176	120	18	36.288	1,524
	18	567	24		18	6.300	265		24	48.384	2,032
	24	756	32		24	8.400	353		30	60.480	2,540
	30	945	40		30	10.500	441		36	72.576	3,048
	36	1,134	48		36	12.600	529		42	84.672	3,556
						42	14.700		617	48	96.768
				48	16.800	706					
20	12	672	28	60	12	6.048	254	130	18	42.588	1,789
	18	1,008	42		18	9.072	381		24	56.784	2,385
	24	1,344	56		24	12.096	508		30	70.980	2,981
	30	1,680	71		30	15.120	635		36	85.176	3,577
	36	2,016	85		36	18.144	762		42	99.372	4,174
	42	2,352	99		42	21.168	889		48	113.568	4,770
				48	24.192	1,016					
25	12	1,050	44	70	12	8.232	346	140	18	49.392	2,074
	18	1,575	66		18	12.348	519		24	65.856	2,766
	24	2,100	88		24	16.464	691		30	82.320	3,457
	30	2,625	110		30	20.580	864		36	98.784	4,149
	36	3,150	132		36	24.696	1,037		42	115.248	4,840
	42	3,675	154		42	28.812	1,210		48	131.712	5,532
48	4,200	176	48	32.928	1,382						
30	12	1,512	64	80	12	10.752	452	150	24	75.600	3,175
	18	2,268	95		18	16.128	677		30	94.500	3,969
	24	3,024	127		24	21.504	903		36	113.400	4,763
	30	3,780	159		30	26.880	1,129		42	132.300	5,557
	36	4,536	191		36	32.256	1,355		48	151.200	6,350
	42	5,292	222		42	37.632	1,581		54	170.100	7,144
48	6,048	254	48	43.008	1,806						
35	12	2,058	86	90	12	13.608	572	160	30	107.520	4,516
	18	3,087	130		18	20.412	857		36	129.024	5,419
	24	4,116	173		24	27.216	1,143		42	150.528	6,322
	30	5,145	216		30	34.020	1,428		48	172.032	7,225
	36	6,174	259		36	40.824	1,715		54	193.536	8,129
	42	7,203	303		42	47.628	2,000				
48	8,232	346	48	54.432	2,286						
40	12	2,688	113	100	18	25.200	1,058	180	30	139.080	5,841
	18	4,032	169		24	33.600	1,411		36	166.896	7,010
	24	5,376	226		30	42.000	1,764		42	194.712	8,178
	30	6,720	282		36	50.400	2,117		48	222.528	9,346
	36	8,064	339		42	58.800	2,470		54	250.344	10,514
	42	9,408	395		48	67.200	2,822				
48	10,752	452									
45	12	3,402	143	110	18	30.492	1,281	200	30	168.000	7,056
	18	5,103	214		24	40.656	1,708		36	201.600	8,467
	24	6,804	286		30	50.820	2,134		42	235.200	9,878
	30	8,505	357		36	60.984	2,561		48	268.800	11,290
	36	10,206	429		42	71.148	2,988		54	302.400	12,701
	42	11,907	500		48	81.312	3,415				
48	13,608	572									

Capacity (barrels) = 0.14 D² H 1 barrel = 42 gallons

INSTRUCTIONS: In a continuing effort to make our standardization documents better, the DoD provides this form for use in submitting comments and suggestions for improvements. All users of military standardization documents are invited to provide suggestions. This form may be detached, folded along the lines indicated, taped along the loose edge (*DO NOT STAPLE*), and mailed. In block 5, be as specific as possible about particular problem areas such as wording which required interpretation, was too rigid, restrictive, loose, ambiguous, or was incompatible, and give proposed wording changes which would alleviate the problems. Enter in block 6 any remarks not related to a specific paragraph of the document. If block 7 is filled out, an acknowledgement will be mailed to you within 30 days to let you know that your comments were received and are being considered.

NOTE: This form may not be used to request copies of documents, nor to request waivers, deviations, or clarification of specification requirements on current contracts. Comments submitted on this form do not constitute or imply authorization to waive any portion of the referenced document(s) or to amend contractual requirements.

(Fold along this line)

(Fold along this line)

DEFENSE LOGISTICS AGENCY



NO POSTAGE
NECESSARY
IF MAILED
IN THE
UNITED STATES

OFFICIAL BUSINESS
PENALTY FOR PRIVATE USE \$300

BUSINESS REPLY MAIL
FIRST CLASS PERMIT NO 4966 WASHINGTON D. C.

POSTAGE WILL BE PAID BY THE DEFENSE LOGISTICS AGENCY

Commander
Defense Fuel Supply Center
ATTN: DFSC-T
Cameron Station
Alexandria, VA 22314

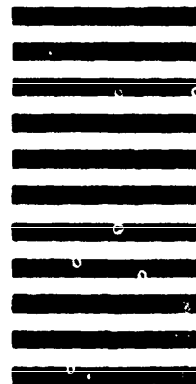

STANDARDIZATION DOCUMENT IMPROVEMENT PROPOSAL

(See Instructions - Reverse Side)

1. DOCUMENT NUMBER

2. DOCUMENT TITLE

3a. NAME OF SUBMITTING ORGANIZATION

4. TYPE OF ORGANIZATION (Mark one)

VENDOR

USER

MANUFACTURER

OTHER (Specify): _____

b. ADDRESS (Street, City, State, ZIP Code)

5. PROBLEM AREAS

a. Paragraph Number and Wording:

b. Recommended Wording:

c. Reason/Rationale for Recommendation:

6. REMARKS

7a. NAME OF SUBMITTER (Last, First, MI) - Optional

b. WORK TELEPHONE NUMBER (Include Area Code) - Optional

c. MAILING ADDRESS (Street, City, State, ZIP Code) - Optional

8. DATE OF SUBMISSION (YYMMDD)

NOTICE OF CHANGE

NOT MEASUREMENT
SENSITIVE

MIL-HDBK-201B(SA)
NOTICE 1
1 October 1992

MILITARY HANDBOOK

PETROLEUM OPERATIONS

TO ALL HOLDERS OF MIL-HDBK-201B(SA), FORMALLY MIL-HDBK-201B:

1. THE FOLLOWING PAGES OF MIL-HDBK-201B(SA) HAVE BEEN REVISED:

NEW PAGE	DATE	SUPERSEDED PAGE	DATE
COVER	1 October 1992	COVER	23 SEPTEMBER 1971
Backside	23 September 1971	Backside	REPRINT WITHOUT CHANGE
99	23 September 1971	99	REPRINT WITHOUT CHANGE
100	1 October 1992	100	23 SEPTEMBER 1971

2. RETAIN THIS NOTICE AND INSERT BEFORE TABLE OF CONTENTS.

3. Holders of MIL-HDBK-201B(SA) will verify that page change and additions indicated above have been entered. This page will be retained as a check sheet. This issuance, together with appended pages, is a separate publication. Each notice is to be retained by stocking points until the military handbook is completely revised or canceled.

Preparing Activity
Navy - SA

Agent
DLA - PS

(PROJECT-91GP1043)

AMSC N/A

FSC 91GP

DISTRIBUTION STATEMENT A. Approved for public release; distribution is unlimited.

MIL-HDBK-201B(SA)
NOTICE 1
1 OCTOBER 1992

NOT MEASUREMENT
SENSITIVE

MIL-HDBK-201B (SA)
23 SEPTEMBER 1971

SUPERSEDING
MIL-HDBK-201A
12 MAY 1961

MILITARY HANDBOOK

PETROLEUM OPERATIONS



AMSC N/A

FSC 91GP

DISTRIBUTION STATEMENT A. Approved for public release; distribution is unlimited.

MIL-HDBK-201B(SA)

NOTICE 1

1 October 1992

MILITARY and FEDERAL Specifications for Petroleum and Petroleum Products Normally Handled in Bulk.

MILITARY:

MIL-F-859	Fuel Oil Burner
MIL-F-16884	Fuel Oil, Diesel Marine
MIL-F-24397 (ships)	Fuel, Navy Distillate
MIL-G-3056	Gasoline, Automotive, Combat
MIL-G-5572	Gasoline, Aviation, Grades 80/87, 100/130, 115/145
MIL-J-25656 (USAF)	Jet Fuel, JP-6
MIL-T-5624	Turbine Fuel, Aviation, Grades JP-4 and JP-5

FEDERAL

VV-F-800	Fuel Oil, Diesel
VV-F-815	Fuel Oil, Burner
VV-G-76	Gasoline, Automotive
VV-K-211	Kerosene

Preparing Activity
NAVY - SA

DEFENSE SUPPLY AGENCY Publications

DFSC	Reference List of Specifications and Standards for Petroleum and Related Products
DSAM 4155.1	Petroleum Procurement Inspection Manual

FEDERAL AND MILITARY Standards, Handbooks Pertaining to Petroleum Products.

a. FEDERAL:

Federal Test Method - Lubricants, Liquid Fuels, and Related Products, Methods of Testing Standard No. 791

b. MILITARY:

MIL-STD-101	Color Code for Pipelines and for Compressed-Gas Cylinders
MIL-STD-140	Procedure for Determining Normal Loss Expectancies for Liquid Petroleum Products
MIL-STD-161	Identification Methods for Bulk Petroleum Products Systems
MIL-STD-290	Packaging, Packing and Marking of Petroleum and Related Products
MIL-HDBK-200	Quality Surveillance Handbook for Fuels, Lubricants and Related Products
MIL-HDBK-210	Planning Factors Handbook

INDUSTRY Publications

API Bulletin RP 2000	Guide for Venting Atmospheric and Low Pressure Storage Tanks
API Bulletin 1501	The Filtration of Aviation Fuels
API Bulletin 1623	Recommended Good Practices for Water Removal from Tanks in Terminals and Depots
API Accident-Prevention Manual No. 13	Cleaning Mobile Tanks Used for Transportation of Flammable Liquids (Section B--Tank Cars)
API Accident-Prevention Manual No. 8	Safe Practices in Bulk Plant Operations
API Bulletin RP 2003	Protection Against Ignitions Arising Out of Static, Lightning, and Stray Currents
API Bulletin 1502	The Installation of Fixed Fuel Handling Equipment at Airports
API Bulletin 1503	The Storage and Handling of Jet Fuels at Airports
API Bulletin 1505	Airport Fueling Systems - Planning Criteria
API Bulletin 1523	Fueling Turbine-Powered Aircraft
API STD 1101	Measurement of Petroleum Liquid Hydrocarbon by Positive Displacement Meters

Copies of the above publications may be purchased from the American Petroleum Institute, 1801 K Street, N.W., Washington, D.C. 20006.

ASTM D1250 and IP:200 Table 5	Reduction of Observed API Gravity at 60°F (American Edition)
ASTM D1250 and IP:200 Table 7	Reduction of Volume at 60°F Against API Gravity at 60°F (Abridged Table) (American Edition)
ASTM Manual D270	Sampling of Petroleum and Petroleum Products
ASTM D1250 and IP:200	Pounds per US Gallon at 60°F and US Gallons at 60°F per Pound Against Specific Gravity at 60°F and Table 26--Pounds per US Gallon at 60°F and US Gallons at 60°F per Pound Against Specific Gravity 60/60°F (American Edition)

Copies of the above tables may be purchased from the American Society for Testing Materials, 1916 Race Street, Philadelphia, Pennsylvania 19103.

MIL-HDBK-201B

OFFICE OF THE ASSISTANT SECRETARY OF DEFENSE

Washington, D. C. 20301

MILITARY HANDBOOK FOR PETROLEUM OPERATIONS
MIL-HDBK-201B

1. This handbook has been approved by the Department of Defense and is for use by the Departments of the Army, the Navy, and the Air Force.

2. Recommended corrections, additions, or deletions should be addressed to the Defense Fuel Supply Center, Cameron Station, Alexandria, Virginia 22314. Copies of this handbook can be obtained through regular channels from the Commanding Officer, Naval Publications and Forms Center, 5801 Tabor Avenue, Philadelphia, Pennsylvania 19120.