

INCH-POUND  
MIL-HDBK-1599A  
2 October 1997  
SUPERSEDING  
MIL-HDBK-1599  
11 March 1997

# DEPARTMENT OF DEFENSE HANDBOOK

BEARINGS, CONTROL SYSTEM COMPONENTS, AND ASSOCIATED  
HARDWARE USED IN THE DESIGN AND CONSTRUCTION OF  
AEROSPACE MECHANICAL SYSTEMS AND SUBSYSTEMS



THIS HANDBOOK IS FOR GUIDANCE ONLY.  
DO NOT CITE THIS DOCUMENT AS A REQUIREMENT

MIL-HDBK-1599A

DEPARTMENT OF DEFENSE  
Washington, DC 20360

Bearings, Control System Components, and Associated Hardware Used in the Design and Construction of Aerospace Mechanical Systems and Subsystems

MIL-HDBK-1599

1. This Military Handbook is approved for use by all Departments and Agencies of the Department of Defense.
2. Beneficial comments (recommendations, additions, deletions) and any pertinent data which may be of use in improving this document should be addressed to ASD/ENESS, Wright Patterson AFB, OH 45433 by using the self-addressed Standardization Document Improvement Proposal (DD Form 1426) appearing at the end of this document or by letter.

## MIL-HDBK-1599A

### FOREWORD

The purpose of this handbook is to establish requirements for the selection and use of bearings, control system components, and associated hardware. The existing documentation on these components covers a great variety of configurations, stress, internal structure, performance variations, materials, and finishes. Of these varieties, many duplicate the fulfillment of design and construction needs for a given application in an aerospace mechanical system, but none has application interchangeability or substitutability. This leads to proliferation of parts. Manufacturers, designers, engineers, and project officers often have problems in the selection of bearings control system components and associated hardware because of lack of knowledge of existing specifications or standards, or application, or where to locate them if they do exist. Additionally, the methods of installation and use of these components vary because of lack of standardized usage criteria and as a result, associated components must vary. The basic objectives of this standard can be summarized as:

"To select from available standards and standardized methods of usage those bearings, control system components and associated hardware which will optimize performance and reliability of future aerospace mechanical systems while minimizing the logistic consideration of such things as cost, inventory, procurement, and maintenance."

It is also the purpose of this document to limit the selection of items and methodology to that specified herein; however, provisions for use of nonapproved parts are covered in Section 100. Requirement 101 is for release for use of components not listed in Section 100, Requirement 102 is for approval of methodology not specifically allowed herein, when required for new design and construction or when maintainability or life cycle cost benefits justify their use.

Selections and procedures are limited to those listed herein.

MIL-HDBK-1599A

CONTENTS

<u>Paragraph</u>		<u>Page</u>
1.	SCOPE	1
1.1	Scope definition	1
1.2	Numbering system	1
1.3	Requirements	1
1.4	Revision of requirements	1
1.5	Changes	1
2.	APPLICABLE DOCUMENTS	1
2.1	Issue of documents	1
2.2	Acquisition of non-government documents	1
3.	DEFINITIONS	2
4.	GENERAL REQUIREMENTS	4
4.1	Application	4
5.	DETAIL REQUIREMENTS	5
6.	NOTES	5
6.1	Marginal indicia	

SECTION 100 - GENERAL

<u>Requirement</u>	<u>Title</u>	<u>Page</u>
101	Approval and Release for Use: Parts	101.1
102	Approval and Release for Use: Methodology	102.1
103	Exchangeability	103.1
104	Materials	104.1
105	Coatings, Platings, and Finishes	105.1
106	Testing	106.1
107	Modification of Parts	107.1
108	Threads	108.1

\* Requirement not as yet published  
 \*\* New in this issue

MIL-HDBK-1599A

SECTION 200 - GENERAL DESIGN REQUIREMENTS

<u>Requirement</u>	<u>Title</u>	<u>Page</u>
201	Bearing Usage <u>1/</u>	201.1
202	Bearing Retention	202.1
203	Component Lubrication	203.1
204	Bearing Safeying Practices	204.1
205	Ball Screw Usage	205.1
206	Control Cable System	206.1
207	Control Rod System	207.1
208	Push-Pull Controls System	208.1
209	(Deleted) Shaft and Pressure Seal Usage	N/A
210	Universal Joints and Flexible Couplings	210.1

SECTION 300 - AIRFRAME BEARINGS

<u>Requirement</u>	<u>Title</u>	<u>Page</u>
301	Airframe Bearings, Ball, Antifriction	301.1
302	Airframe Bearings, Antifriction Roller	302.1
303	Antifriction, Needle, Including Track Rollers	303.1
304	Antifriction, Miniature	304.1
305	Fluid Film	305.1
306	Spherical, All-metal	306.1
307	Spherical, Non-metallic and	307.1
308	Rod Ends	308.1
309	Journal and Bushings, All-metal	309.1
310	Journal and Bushings, Non-Metallic and Non-metallic Lined	310.1
311	Linear Motion, Antifriction	311.1
312	Special Purpose Designs	312.1
313	Bearing, Sleeve, Non-Metallic Self-Lubrication	313.1

SECTION 400 - BEARING RETAINER RINGS, WASHERS, NUTS

<u>Requirement</u>	<u>Title</u>	<u>Page</u>
401	Retaining Rings	401.1
402	Nuts and Locking Devices	402.1

\* Requirement not as yet published

\*\* New in this issue

1/ Due to the length of this requirement, a table of contents is included for convenience.

MIL-HDBK-1599A

SECTION 500 - GREASE/OIL SEALS NON-INTEGRAL

<u>Requirement</u>	<u>Title</u>	<u>Page</u>
501	Grease Fittings	501.1
502 (Deleted)	Shaft Seals	N/A

SECTION 600 - CONTROL CABLE SYSTEMS

<u>Requirement</u>	<u>Title</u>	<u>Page</u>
601	Control Cable Assembly Components	601.1
602	Control Rods	602.1
603	Pulleys, Rollers, Fairleads	603.1
604	Bolts, Shaft, Dual Safetying	604.1
605	Environmental Pressure Seals	605.1
*606	Push-Pull Controls	

SECTION 700 - LATCH COMPONENTS

<u>Requirement</u>	<u>Title</u>	<u>Page</u>
701	Bearing Shaft Bolts	701.1
702	Nuts	702.1

SECTION 800 - (Deleted)

<u>Requirement</u>	<u>Title</u>	<u>Page</u>
801 (Deleted)		N/A

SECTION 900 - MECHANICAL DRIVE COMPONENTS

<u>Requirement</u>	<u>Title</u>	<u>Page</u>
901	Universal Joints	901.1
*902 (Not Available)	Flexible Couplings	

\* Requirement not as yet published

\*\* New in this issue

MIL-HDBK-1599A

BEARINGS, CONTROL SYSTEM COMPONENTS, AND ASSOCIATED  
HARDWARE USED IN THE DESIGN AND CONSTRUCTION OF  
AEROSPACE MECHANICAL SYSTEMS AND SUBSYSTEMS

1. SCOPE

1.1 Scope. This handbook is intended to assist engineers in the design and construction of aerospace mechanical systems for military aircraft. It is intended to serve the engineer by fostering the use of approved standards parts while allowing the freedom to choose non-standard or special parts when a particular application warrants it. It is intended to neither tie the designer's hands nor to grant unlimited license. This handbook is intended to assist engineers: (a) by providing design guidance based on industry-proven engineering practices for bearings, control system components and associated hardware used in aerospace mechanical systems; (b) by requiring the use of approved standard parts in these systems to the largest extent practicable; and (c) by providing for the selection and approval of special parts, when those are necessary and appropriate, through the use of defined procedures.

1.2 Numbering system. This handbook is divided into sections with numbered requirements applicable to each section.

1.3 Requirements. The sections and numbered requirements of this document provide: (a) recommended criteria for parts selection; (b) identify approved standard parts; (c) define required procedures for use of non-standard parts; and (d) define approved engineering practices for installation, lubrication, safetying, material and finish selection, and tests for bearing, control system components and associated hardware used in the design and construction of aerospace mechanical systems.

1.4 Revision of requirements. This handbook is issued in loose leaf form to permit the insertion or removal of new or revised requirements. Users should keep this document up to date by inserting revised or new sections as issued and removing superseded or canceled pages. Revisions to individual pages shall be indicated by a revision date at the bottom right side of the page. Revision to a complete section shall be denoted by a letter following the requirement designation. For example: Requirement 100A followed by the date.

1.5 Changes. Requests for changes to this document shall be submitted to : Warner-Robins Air Logistics Center, 460 2nd Street, Suite 221, WR-ALC/LKJE, Robins Air Force Base, GA 31098-1640.

2. APPLICABLE DOCUMENTS

2.1 Issues of documents. See each individual requirement for reference to any applicable documents contained therein. The applicable issues shall be those in effect on the date of invitation for bids or request for proposal.

(Copies of specifications, standards, drawings, and publications required by contractors in connection with specific procurement functions should be obtained from the procuring activity or as directed by the contractor officer.)

2.2 Acquisition of non-government documents referenced herein. Addresses for documents not obtainable from the government which are referenced herein are as follows:

ANSI	American National Standards Institute 1430 Broadway New York, NY 10018	ASTM	American Society of Testing and Materials 1916 Race Street Philadelphia, PA 19103
NAS	National Standards Association 1321 Fourteenth St., NW Washington, DC 20005	AMS, AS, ARP AIR, AMD	Society of Automotive Engineers 400 Commonwealth Drive Warrendale, PA 15096

MIL-HDBK-1599A

3. DEFINITIONS

- 3.1 Airframe bearing. A bearing especially designed for use in the control systems and surfaces of the aircraft.
- 3.2 Aligning thrust bearing, ball, or roller. A thrust ball or roller bearing which by virtue of the shape of the seat washer is capable of considerable misalignment.
- 3.3 Annular Bearing. An antifriction bearing primarily designed to support load perpendicular to shaft axis.
- 3.4 Ball bearing. An antifriction bearing using balls as rolling element.
- 3.5 Cam follower ball bearing. Special service ball bearing with extra heavy outer ring.
- 3.6 Clutch release ball bearing. A line of bearings designed for this special purpose.
- 3.7 Cylindrical roller bearing. Roller surface parallel to bearing axis.
- 3.8 Double row bearing, ball or roller. A bearing with two rows of rolling elements.
- 3.9 Duplex ball bearing. Two single row angular contact bearings selected dimensionally to be a matched pair or set.
- 3.10 Duplex ball bearing, back-to-back. A duplex pair of angular contact ball bearings with outer ring thrust faces adjacent and with ball load lines intersecting outside the pitch circle.
- 3.11 Duplex ball bearings face-to-face. A duplex pair of angular contact ball bearings with outer ring narrow faces adjacent and with ball load lines intersecting inside the pitch circle.
- 3.12 Duplex ball bearing, tandem. Assembly of two or more ball bearings so mounted as to divide the thrust load with ball load lines parallel.
- 3.13 Flanged bearing. Generally descriptive of antifriction bearings with outer ring or cup flanged on outside diameter.
- 3.14 Floating bearing. A floating bearing is one so designed or mounted as to permit axial displacement between shaft and housing.
- 3.15 Journal roller bearing. A cylindrical roller bearing (solid or wound rollers) with relatively high ratio roller length to diameter, separable rings and unit type roller assembly.
- 3.16 Maximum type roller bearing. CAGEless roller bearing with maximum number of rollers.
- 3.17 Metric bearing. A bearing designed to metric dimensions.
- 3.18 Miniature ball bearing. Ball bearings whose outside diameter dimensions are below and not including 3/8" or 9mm.

MIL-HDBK-1599A

- 3.19 Multi-row bearing, ball or roller. A bearing with more than two rows of rolling elements.
- 3.20 Needle roller bearing. A radial needle roller bearing is a radial cylindrical roller bearing having a large ratio of pitch diameter to roller diameter and a large ratio of roller length to roller diameter.
- 3.21 Non-filling slot bearing. See roller bearing.
- 3.22 Outside cylindrical surface run-out with reference side. A bearing measurement defined in Anti-Friction Bearing Manufacturers Association (AFBMA) Standard Section No. 4.
- 3.23 Preload. Preload commonly refers to an internal loading characteristic in a bearing which is dependent of any external radial or axial load carried by the bearing.
- 3.24 Prelubricated bearing. A bearing originally lubricated by the manufacturer.
- 3.25 Pure radial load. Pure radial load is that load which results from a single source acting through the center of the bearing at right angles to the bearing axis.
- 3.26 Pure thrust load. Pure thrust load is that load which results from a single force applied in the direction coaxial with the bearing axis.
- 3.27 Races. The inner ring or outer ring of a cylindrical or needle roller bearing.
- 3.28 Raceway, inner ring. The path of the roller element on either ring of a ball or roller bearing.
- 3.29 Raceway depth. In a ball bearing, the vertical distance from bottom of raceway to inner ring outside diameter, or outer ring inside diameter.
- 3.30 Raceway, parallel with side. A bearing measurement defined in AFBMA Standard Section No. 4, as "Groove Runout with Reference Side."
- 3.31 Radial bearing. An antifriction bearing primarily designed to support load perpendicular to shaft axis.
- 3.32 Radial internal clearance. The radial internal clearance of a single row radial contact ball bearing is the average outer ring raceway diameter, minus the average inner ring raceway diameter, minus twice the ball diameter. The raceway diameters are taken at the bottom of the raceway.
- 3.33 Radial load. Radial load is that load which may result from a single force or the "resultant" of several forces acting in a direction at right angles to the bearing axis.
- 3.34 Radial play. See radial internal clearance.
- 3.35 Rating life. This term defined in AFBMA Standard section no. 9.
- 3.36 Roller bearing. A bearing using rollers as roller elements.

MIL-HDBK-1599A

- 3.37 Seals: lip, felt type, labyrinth type. A seal in sliding contact with a rotating ring. Closure elements consisting of a circular part or parts affixed to one bearing ring and disposed radially toward the other bearing ring (or another member affixed to that ring), to run in close proximity thereto, and shaped to form a labyrinth of appreciable length.
- 3.38 Sealed bearing. A ball or roller bearing protected against loss of lubricant and from outside contamination.
- 3.39 Sealed and shielded bearing. Sealed on one side, shielded on other side.
- 3.40 Self-aligning radial bearing, ball or roller. A ball or roller bearing which by virtue of the raceway or outer ring construction, is capable of considerable misalignment.
- 3.41 Self-contained bearing. A unit bearing assembly (non-separable).
- 3.42 Separable bearing, ball or roller. A bearing assembly that may be separated completely or partially into its component parts.
- 3.43 Shielded and sealed bearing. Shielded on one side, sealed on the other.
- 3.45 Single sealed bearing. Sealed on one side.
- 3.46 Single shielded bearing. Shielded on one side.
- 3.47 Spherical bearing. A bearing not meeting the requirements of Standard or Established Line Bearings.
- 3.48 Spherical roller bearing (radial). See Self-aligning radial bearing.
- 3.49 Spherical roller thrust bearing. See Self-aligning radial bearing.
- 3.50 Split bearing, single or double fracture. A bearing having either or both rings split across the raceway so as to facilitate assembly in certain applications.
- 3.51 Stand out, tapered roller bearing. The distance from the back face of the cone to the front face of the cup.
- 3.52 Straight roller bearing. A roller bearing of the radial type-having cylindrical rollers.

4. GENERAL REQUIREMENTS

4.1 Application. The sections and requirements contained herein are intended to provide uniform requirements applicable to bearings, control system components, and associated hardware for use on aerospace mechanical systems and shall be incorporated by reference in general and detail weapon systems and equipment specifications. If a requirement contained herein conflicts with a requirement in the general or detail weapon system or equipment specification, the weapon system or equipment specification shall take precedence. If the requirement listed in the Table of Contents has not been published but is referenced herein, it is not applicable, and the requirements of the general or detail weapon system or equipment specification shall apply

MIL-HDBK-1599A

5. DETAIL REQUIREMENTS

5.1 Individual requirements. Individual requirements for each section follow.

6. NOTES

6.1 Marginal indicia. The margins of this handbook will be marked to indicate where changes, deletions, or additions to the previous issue have been made. This is done as a convenience only and the Government assumes no liability whatsoever for any inaccuracies in these notations. Bidders and contractors are cautioned to evaluate the requirements of this document based on the entire content as written, irrespective of the marginal notations and relationship to the previous issue.

Custodians:

Army - AV  
Navy - AS  
Air Force - 99

Preparing activity:

Air Force - 84

Review activities:

DLA - IS

Project 31GP-0026

CONTENTS

<u>Paragraph</u>		<u>Page</u>
	Index	201.i-ii
1.	Scope Bearing Usage	201.1
1.1	Approved Bearings	201.1
2.	Applicable Documents	201.1
3.	Bearing definitions, terminology and descriptions	201.3
3.1	Definitions and terminology	201.3
3.2	Bearing type terminology descriptions	201.3
3.2.1	Anti-friction bearings	201.3
3.2.1.1	Ball bearings	201.3
3.2.1.2	Needle bearings	201.5
3.2.1.3	Roller bearings	201.5
3.2.2	Plain bearings	201.6
3.2.2.1	Spherical bearings	201.6
3.2.2.2	Journal bearings	201.6
3.2.3	Rod end bearings	201.7
3.2.4	Miscellaneous bearings	201.7
3.2.4.1	Linear motion ball bearings	201.7
3.2.4.2	Pillow block bearings	201.7
3.2.4.3	Instrument bearings	201.7
3.2.4.4	Loader slot spherical bearings	201.7
3.2.4.5	Snap assembly spherical bearings	201.8
4.	Bearing selection	201.8
4.1	Selection within types	201.8
4.1.1	Anti-friction bearings	201.8
4.1.2	Plain bearings	201.8
4.2	Selection for systems applications	201.8
4.2.1	Primary control systems	201.9
4.2.2	Secondary auxiliary control systems	201.9
4.2.3	Landing gear	201.9
4.2.4	Flaps and spoilers	201.10
4.3	Selection based on bearing characteristics	201.10
4.3.1	Friction	201.19
4.3.2	Torque	201.19
4.3.2.1	Anti-friction bearings	201.19
4.3.2.2	Plain bearings	201.20
4.3.3	Temperature capability	201.20
4.3.4	Load capacity	201.23
4.3.4.1	Anti-friction bearings	201.23
4.3.4.1.1	Ball bearings	201.23
4.3.4.1.2	Roller bearings	201.32
4.3.4.1.3	Needle bearings	201.36
4.3.4.2	Plain bearings	201.43
4.3.4.2.1	Spherical, TFE lined	201.43
4.3.4.2.2	Spherical, Grease or Dry Film lubricated	201.45
4.3.4.2.3	Journal, TFE lined	201.45
4.3.4.2.4	Journal, Metallic	201.47

MIL-HDBK-1599A

REQUIREMENT 201

CONTENTS - Continued		
<u>Paragraph</u>		<u>Page</u>
5.	Installation and retention	201.48
6.	Miscellaneous design considerations	201.49
6.1	Lubrication provisions	201.49
6.2	Bearing safety	201.49
7.	Quality assurance provisions in design	201.50
7.1	Proof loading for retention	201.50
7.2	Safetying	201.50
7.3	Starting torque	201.50

MIL-HDBK-1599A

REQUIREMENT 201

BEARING USAGE

1. Scope. This requirement establishes criteria and information relative to selection of bearings in aerospace vehicle applications. Only those bearings used in the aerospace vehicle proper are covered. Bearings used in specific equipment such as engines, generators, gear boxes, and landing gear wheels are excluded from coverage in this requirement.

1.1 Approved bearings of various types shall be as listed in the appropriate section 300 requirement of this document. Until publication of the specific requirements, there are no approved or disapproved bearings. Bearings of all types covered herein shall be selected in accordance with the criteria and guidelines of this requirement. Submittal of such selections per requirement 101 is not required until such time as appropriate section 300 requirements are published.

2. Applicable Documents.

QQ-C-465	Copper-Aluminum Alloys (Aluminum Bronze) (Copper Alloy Numbers 606, and 642) Rod, Flat Products with Finished Edges (Flatwise, Strip, and Bar), Shapes, and Forgings	614,630,
QQ-C-530C	Copper-Beryllium Alloy Bar, Rod, and Wire (copper alloy numbers 172 and 173)	
MIL-B-3990	Bearings, Roller, Needle, Airframe, Anti-Friction	
MIL-B-6039	Bearing, Double Row, Ball, Sealed Rod End, Anti-Friction, Self-Aligning	
MIL-B-7949	Bearings, Ball, Airframe, Anti-Friction	
MIL-B-8914	Bearing, Roller, Self-Aligning, Airframe, Anti-Friction	
MIL-B-8952	Bearing, Roller, Rod End, Anti-Friction, Self-Aligning	
MIL-B-8976	Bearings, Plain, Self-Aligning, All-Metal	
MIL-G-23827	Grease, Aircraft and Instruments, Gear and Actuator Screw	
MIL-G-81322	Grease, Aircraft, General Purpose, Wide Temperature Range	
MIL-B-81819	Bearings, Plain, Self-lubricating, Self-Aligning, High Speed Oscillation	
MIL-B-81820	Bearings, Plain, Self-Aligning, Self-Lubricating, Low Speed Oscillation	
MIL-B-81934	Bearings, Sleeve, Plain and Flanged, Self-Lubricating	
MIL-B-81934/1	Bearing, Sleeve, Plain, Self-Lubricating, 325°F	
MIL-B-81934/2	Bearing, Sleeve, Flanged, Self-Lubricating, 325°F	
MIL-B-81935	Bearing, Plain, Rod End, Self-Aligning, Self-Lubricating	
MIL-B-81935/1	Bearing, Plain, Rod End, Self-Aligning, Self-Lubricating, Externally Threaded, -65°F to +325°F	
MIL-B-81935/2	Bearing, Plain, Rod End, Self-Aligning, Self-Lubricating, Internally Threaded, -65°F to +325°F	
MIL-B-81936	Bearing, Plain, Self-Aligning (BeCu CRES Race), General Specification for	
MIL-B-81936/1	Bearings, Plain, Self-Aligning, BeCu Ball, CRES Race, (With Staking Groove), -65°F to +350°F	
MIL-B-81936/2	Bearings, Plain, Self-Aligning, BeCu Ball, CRES Race, -65°F to +350°F	
MS14101	Bearing, Plain, Self-Lubricating, Self-Aligning, Low Speed, -65°F to 325°F, Narrow, Grooved Outer Ring	
MS14102	Bearing, Plain, Self-Lubricating, Self-Aligning, Low Speed, Wide, Chamfered Outer Ring, -65°F to 325°F	

MIL-HDBK-1599A

REQUIREMENT 201

MS10403	Bearing, Plain, Self-Lubricating, Self-Aligning, Low Speed, Wide, Grooved Outer Ring, -65°F to 325°F	
MS14104	Bearing, Plain, Self-Lubricating, Self-Aligning, Low Speed, Narrow, Chamfered Ring, -65°F to 325°F	Outer
MS21150	Bearing, Double Row, ball, Rod End, Precision, Solid Shank, Self-Aligning, Anti-Friction, Airframe, Type 1, -65°F to 350°F	
MS21151	Bearing, Double Row, Ball, Rod End, Precision, External Thread, Self-Aligning, Anti-Friction, Airframe, Type II, -65°F to 350°F	
MS21152	Bearing, Double Row, Ball, Rod End, Precision, Hollow Shank, Self-Aligning, Anti-Friction, Airframe, Type III, -65°F to 350°F	
MS21153	Bearing, Ball, Rod End, Precision, Internal Thread, Self-Aligning, Anti-Friction, Airframe, Type IV, -65°F to 350°F	
MS21154	Bearing, Plain, Self-Aligning, Grooved Outer Ring	
MS21155	Bearing, Plain, Self-Aligning	
MS21220	Bearing, Roller, Rod End, Internal Thread, Self-Aligning, Anti-Friction, Airframe, Heavy Duty, Type II, -67°F to 350°F, Sealed	
MS21221	Bearing, Roller, Rod End, External Thread, Self-Aligning, Anti-Friction, Airframe, Heavy Duty, Type I, -67°F to 350°F, Sealed	
MS21223	Bearing, Roller, Rod End, External Thread, Self-Aligning, Anti-Friction, Airframe, Heavy Duty, Type II, -67°F to 350°F, Sealed	
MS21428	Bearing, Ball, Airframe, Anti-Friction, Extra Light Duty, Precision	
MS21432	Bearing, Roller, Needle, Track Roller, Integral Stud, Type VII, Anti-Friction, Inch	
MS24461	Bearing, Roller, Needle, Single Row, Heavy Duty, Type I, Anti-Friction, Inch	
MS24462	Bearing, Roller, Needle, Single Row, Thin Shell, Type II, Anti-Friction	
MS24463	Bearing, Roller, Needle, Single Row, Heavy Duty, Self-Aligning Type III, Anti-Friction, Inch	
MS24464	Bearing, Roller, Needle, Double Row, Heavy Duty, Self-Aligning, Type IV, Anti-Friction, Inch	
MS24465	Bearing, Roller, Needle, Single Row, Heavy Duty, Track Roller, Type V, Anti-Friction, Inch	
MS24466	Bearing, Roller, Needle, Double Row, Heavy Duty, Track Roller, Type VI, Anti-Friction, Inch	
MS27640	Bearing, Ball, Airframe, Anti-Friction, Heavy Duty	
MS27641	Bearing, Ball, Airframe, Anti-Friction, Intermediate Duty	
MS27642	Bearing, Ball, Airframe, Extra Light Duty	
MS27643	Bearing, Ball, Airframe, Anti-Friction, Self-Aligning, Double Row, Heavy Duty,	
MS27644	Bearing, Ball, Airframe, Anti-Friction, Double Row, Heavy Duty	
MS27645	Bearing, Ball, Airframe, Anti-Friction, Self-Aligning, Light and Heavy Duty	
MS27646	Bearing, Ball, Airframe, Anti-Friction, Extra Light Duty	
MS27647	Bearing, Ball, Airframe, Anti-Friction, Extra Wide, Double Row, Intermediate Duty	
MS27648	Bearing, Ball, Airframe, Anti-Friction, Externally Self-Aligning, Extra Light	
MS27649	Bearing, Ball, Airframe, Anti-Friction, Intermediate Duty	
MS28913	Bearing, Roller, Self-Aligning, Double Row, Airframe, Anti-Friction, Sealed, Type II	
MS28914	Bearing, Roller, Self-Aligning, Double Row, Wide Inner Ring, Airframe, Anti-Friction, Sealed, Type III	Friction,

MIL-HDBK-1599A

REQUIREMENT 201

MS28915	Bearing, Roller, Self-Aligning, Double Row, Torque Tube, Airframe, Anti-Friction, Sealed, Type IV
AMS 4640	Rods, Bars, and Forgings, Aluminum Bronze, 81.5 Cu, 10.3 Al, 5 Ni, 2.8 Fe
AMS 4880	Castings, Centrifugal Aluminum Bronze, 81.5 Cu, 10.3 Al, 5 Xi, 2.8 Fe
AMS 5630	Bars and Forgings 17 Cr, 0.5 Mo (0.95-1.20 C)
AMS 5643	Bars, Forging, Tubing and Rings, 16 Cr, 4.0 Ni, 0.30 (Cb + Ta) 4. Cu
NAS 72	Bushing, Clamp-up, Steel, Chrome-Plated
NAS 73	Bushing, Clamp-up, Steel, Cadmium Plated
NAS 74	Bushing, Clamp-up, Bronze
NAS 75	Bushing, Plain, Press-Fit, Steel
NAS 76	Bushing, Plain, Press-Fit, Bronze
NAS 77	Bushing, Flanged, Press-Fit, Steel and Bronze
NAS 537	Bushing, Sleeve, Press-Fit, Undersize Inside Diameter
NAS 538	Bushing, Flanged, Press-Fit, Undersize Inside Diameter

AFBMA standards, section no. 1, "Terminology and Definitions for Anti-Friction Ball and Roller Bearings and Parts".

3. Bearing definitions, terminology and descriptions. Aerospace vehicle bearings as used herein, is a term which applies to all types of bearings used in the design of the actual aerospace vehicle excluding those bearings used in equipment and machinery of a specialized nature such as engines, generators gear boxes and landing gear wheels.

3.1 Definitions and terminology. Definitions and terminology, as used herein, shall be based on AFBMA section no. 1, "Terminology and Definitions for Anti-Friction Ball and Roller Bearings and Parts". This base will be modified and augmented by those definitions and that terminology generally accepted currently by the Bearing Manufacturing and Airframe Manufacturing Industries and the using U.S. Government Services.

3.2 Bearing type descriptions. Bearings are generally classified into several "types" based on details of geometry and construction and on the nature of usage. The following types are common in aerospace vehicle design.

3.2.1 Anti-friction bearings. These bearings are commonly termed "rolling element bearings" and the terms are used interchangeably. They utilize a complement of balls, rollers, or needles separating an outer ring and an inner ring. The outer ring is usually mounted in the housing and the inner ring on a shaft. Other elements of these bearings may be rolling element separators, shields or seals, and seal retainers

3.2.1.1 Ball bearings. The ball bearings used in aerospace vehicles are primarily annular ball bearings. Linear motion ball bearings are used in a few special applications. Annular ball bearings are intended for use in rotational or oscillatory applications, under radial, axial, or combination loading. Linear motion ball bearings (or bushings) are intended for linear or axial motion between the shaft and housing and have no axial or thrust load capability. Annular ball bearings are available, within a given configuration, with varying numbers of balls in the rolling element complement. The three common configurations are illustrated in figure 201-2. Several configurations of ball bearings have been standardized and developed specifically for airframe use. They generally have rugged construction, full ball complements, seals, and corrosion resistant plating. They are intended for heavy, oscillatory loads and have no relubrication capacity.

3.2.1.1.1 Ball complement. Most types of ball bearings are available in three configurations, each containing a different complement of balls (see figure 201-2) as follows:

- a. Full complement (filling slot type). This bearing configuration contains the maximum quantity of balls, with no cage or retainer separating the balls. It is best suited to most airframe applications as it will withstand the highest loads and is most satisfactory for oscillating or low speed loads not exceeding 500 rpm.
- b. Maximum complement (filling slot type). This bearing configuration contains the maximum quantity of balls, with a cage or retainer separating the balls, and is for heavy radial loads at speeds not exceeding 5000 rpm. The thrust load capability is somewhat less than half the static load limit.
- c. Conrad. This bearing configuration contains a cage or retainer to separate the balls, has no filling slot and is for relatively light radial loads but high speed applications not to exceed 15,000 rpm. Thrust and radial capacity are approximately equal and about one-third the static limit capacity of the full complement type. The Conrad bearing has the lowest load capacity of the three types of ball bearings because it contains fewer balls. The number of balls is limited by the method of assembly.

3.2.1.1.2 Typical airframe ball bearings. Bearings of various configurations and capacities are available for airframe use where radial loads are large, thrust loads relatively small, and misalignment is less than 15 minutes of arc. They are given a letter type designation and an MS number and include: MS27640(KP), MS27641(KP-A), MS27642(KP-B), and MS27644(DPP). Where the alignment exceeds 15 minutes of arc, bearings of similar geometry to the above are available with aligning capability but with some sacrifice in load capacity. They include MS27645(KSP & KSP-A) and MS27643(DSP). These typical airframe bearings are listed in table 201-I. Other characteristics and applications of ball bearings include:

- a. Low torque
- b. For oscillating motion or slow intermittent rotation (below 500 revolutions per minute (rpm) for general airframe use)
- c. Designed to carry radial and thrust loads
- d. Low static load capacity
- e. Good radial and axial position accuracy
- f. Prelubricated for rated life of bearing but no provisions for relubrication. (See requirements 301 and 304 for specific approved bearings.)

3.2.1.1.3 Airframe torque tube bearings. Extra light duty ball bearings of the MS27642(KP-B) and MS27646(B50ODD) series are used in relatively large diameter torque tube applications where radial loads are large, thrust loads are small, and misalignment is less than 15 minutes of arc. For torque tube applications where initial installation misalignment occurs, and thrust loads are small and unidirectional, M27648(KP-BS) self-aligning bearings may be used. They are not dimensionally interchangeable with the NS27642(KP-B) bearings. Bearings with self-aligning outer rings shall not be used for operational misalignment as they are designed to accommodate only initial installation misalignment.

3.2.1.2 Needle bearings.

3.2.1.2.1 Typical airframe needle bearings. Needle bearings carry higher radial loads, within a particular envelope, than other types of antifriction bearings. For optimum performance, installation alignment must be good, shaft deflection limited, and thrust loads avoided. Type MS24462(NCC) bearings must be supported in rigid housings because of their thin outer race. Type MS24463(NBE) and MS24464(NBK) may be used where limited initial installation alignment occurs. (Typical needle bearings are listed in table 201-II. Specification approved bearings are listed in requirement 303.) Characteristics and applications of needle bearings include:

- a. Low torque
- b. For oscillating motion and slow intermittent rotation (below 100 rpm)
- c. Designed to carry radial loads
- d. Can be relubricated
- e. Alignment of needle bearings other than self-aligning types is critical; misalignment will result in limited life.
- f. Adequate lubrication and occasional rotation through, an angle greater than 15° is necessary to minimize fretting.

NOTE: For the purposes of this discussion, an airframe needle bearing contains a full complement of needle rollers; there are no separators or retainers in airframe needle bearings.

3.2.1.2.2 Track rollers, yoke type and stud type. Special needle bearings are available for use in rolling applications on tracks such as in wing flap applications. Single row MS24465(NBF) and double row MS24466(NBL) track rollers are available for clevis mounting in a yoke. MS21432(HRS) cam followers have an integral stud for cantilever mounting. These bearings are illustrated in table 201-II. The crowned rollers are not intended for deliberate misalignment in applications, but will compensate for small amounts of adverse dimensional tolerance and deflection induced misalignment.

3.2.1.3 Roller bearings. Typical roller bearings are listed in table 201-III. See requirement 302 for specifically approved bearings.

3.2.1.3.1 Typical airframe roller bearings. Roller bearings are useful for applications where loading is beyond the capability of comparable size ball bearings and where a combination of the following characteristics is desirable in the design application:

- a. All types are self-aligning.
- b. Accept slow rotation (below 100 rpm) in addition to oscillation.
- c. All types are pre-lubricated and have provision for relubrication, except MS28912 bearings.
- d. Low torque.

- e. Carry radial, thrust, and combined loads.
- f. Equipped with seals.
- g. Corrosion-resistant plating.

3.2.1.3.2 Airframe torque tube bearings. Light duty roller bearings of the MS28915 series are used in relatively large diameter torque tube applications where radial loads are large and thrust loads minimal.

3.2.2 Plain bearings. This class of bearings is frequently referred to as "sliding surface bearings" and includes all types of bearings in which surfaces slide relative to one another, whether separated by a lubricant or in intimate contact. Included are cylindrical sleeves or bushings as used in so-called "static joint" applications. Plain bearings are divided into spherical, cylindrical, rod ends, and special bearings based on the design geometry and application.

3.2.2.1 Spherical bearings. The term spherical bearing as used herein refers to a bearing composed of a spherical shaped piece with a hole for a shaft and employed as an inner race and spherically concave single piece outer member conforming to the shape of the inner race. A grease lubricant, dry film lubricant, or TFE type liner may be employed between the races for lubrication. The outer member may be permanently swaged around the outer portion of the inner or slotted to accept the inner member. The two types of spherical bearings are therefore identified as the metal-to-metal type and the lined type. Both types are included in table 201-IV.

3.2.2.1.1 Metal-to-metal type. These bearings can be used in basically all airframe applications with lubricant provisions per requirement 203. Dry film lubrication may be used in certain applications where there is limited bearing motion under load or where elevated temperatures are beyond the grease capability. When these bearings are used in the pilot feel portion of primary control systems, it is essential to determine that friction levels and radial play are acceptable. Table 201-IV shows typical bearings of this type and approved bearings are specified in requirement 306.

3.2.2.1.2 Lined type bearings. These bearings are used in similar applications to the metal-to-metal type where relubrication is impossible or undesirable. The liners are sacrificial and normal wear rates can be accelerated by liquid contaminants, temperature extremes, and impact loading. The designer must size these bearings so that adequate life is attained under the service loading and environment. Table 201-IV shows typical bearings of this type and approved bearings are specified in requirement 307. As with metal-to-metal bearings, it is essential to determine that friction levels and radial play due to wear are acceptable when these bearings are used in the pilot-feel portion of primary control systems.

3.2.2.2 Journal bearings. Journal bearings are used in aerospace vehicle applications similar to those in which plane spherical bearings are used. However, they have no misaligning capability. They are of simple construction with a flanged or unflanged "sleeve", or "bushing" acting as the outer member and rotation occurring between the sleeve and a structure connecting shaft or pin. These bearings are available with the same lubrication options as is afforded on the inside diameter (ID) of spherical bearing outer races. Material choices are also similar, as are load capability and application limitations. Journal bearings may be used without lubrication provisions in static joints to protect structure and provide an economical, easily replaced design element. Table 201-V shows typical standard journal bearings and bushings. Approved journal bearing standards are specified in requirements 309 and 310. All others require specific approval in accordance with requirement 101.

3.2.3 Rod end bearings. These bearings are intended for use on push-pull rods as end fittings to permit functional attachment to mechanisms and structure. They consist of a self-aligning bearing in housing with an integral shank for attachment to the rod. They are available with antifriction ball or roller bearings and with metal-to-metal or lined plain spherical bearings. Shanks may be solid or hollow and may be either internally or externally threaded as appropriate for the designed attachment. Limitations on applications are governed by the insert or "cartridge" bearings and on fatigue considerations of the housing. Typical rod end bearings are illustrated and described in table 201-VI. Requirement 308 specifies approved rod end bearings.

3.2.4 Miscellaneous bearings. Several other types of bearings are of linear motion occasionally used in aerospace vehicle design. These consist ball bearings (ball bushings), pillow block bearings, instrument bearings, loader slot spherical bearings, and snap assembly spherical bearings.

3.2.4.1 Linear motion ball bearings. These bearings are used in applications where slow axial travel, with or without limited rotation, is a design requirement. (Typical linear motion ball bearings are illustrated in figure 201-1.) Their use should be limited to those standards specified in requirement 311 and within the following:

- a. Rotary motion less than  $360^\circ$  and not to exceed 10 rpm
- b. Shaft hardness of at least Rc 50
- c. Shaft surface 125 RHR or better

3.2.4.2 Pillow block bearings. Pillow block bearings are sometimes used for mounting equipment and mechanisms. They consist of a bolt-down housing with a variety of types of cartridge bearings. They are not included in the scope of MIL-HDBK-1599 and must be individually selected or designed and approved per requirement 101.

3.2.4.3 Instrument bearings. These bearings are included in the design of many types of equipment used on aerospace vehicles. As such they are not presently within the scope of MIL-HDBK-1599. If used as aerospace vehicle proper design they require approval in accordance with requirement 101.

3.2.4.4 Loader slot spherical bearings. There are numerous designs that fall into the general category of loader slot (Messerschmidt) bearings. Each has its own advantages and disadvantages. The following discussion applies to loader slot bearings as a group.

- a. A major advantage of loader slot bearings is the close tolerance that can be achieved by grinding the inside spherical diameter of the outer ring. Excellent conformity between ball and outer race can be accomplished. This also means that a close tolerance on radial and axial play can be accomplished. This advantage is not so pronounced on small diameter bearings since conformity is fairly easy to achieve on small parts by swaging.
- b. Very high strength steels or specialty materials can be used in the outer race for better wear characteristics, high static load capacity, high temperature capability, corrosion resistance, or other special requirements. In a swaged bearing the race is usually relatively soft and ductile to prevent race cracking during swaging and to get good conformity. It should be noted here that it is possible to make a swaged

bearing with a relatively hard outer race by using maraging steel components which can be heat treated after the swaging process. In some applications it is also possible to gain the advantages of a hard outer race without the disadvantages of a loader slot bearing by using the fractured outer race technique.

c. It is possible to replace the ball in the field without replacing the entire bearing.

d. The requirement to properly orient the slot with respect to the load is a major disadvantage of loader slot bearings. In some applications where load varies in direction over 600 to 900, it is impossible. If reverse loader slot bearings are used (ball has the reduced section instead of the race) proper orientation is impossible.

e. A loader slot can significantly reduce the bearing area. Selection should be limited to bearings with fairly narrow balls to prevent this loss from being excessive.

f. It is difficult to retain grease and keep dirt and contaminants out unless the loading slot is sealed. It is possible to seal the loading slot, but this can reduce the effective bearing area and makes the bearing more expensive.

3.2.4.5 Snap assembly spherical bearing. These bearings are not covered by MS standards. They are of a torque tube bearing configuration with large diameter-to-width ratios. The races are sufficiently thin as to permit assembly of the ball within the race by elastic deformation. As non-standard bearings, they require approval in accordance with requirement 101 for use in aerospace vehicle design.

4. Bearings selection. In selecting a bearing for a specific aerospace vehicle application, the functional characteristics of the bearing must be optimally matched against the application requirements. The bearing type must be determined through an evaluation of envelope dimensions, unique geometry, and load and life characteristics.

4.1 Selection within types. The two types of bearings considered are anti-friction or "rolling element" bearings and plain or "sliding surface" bearings.

4.1.1 Anti-friction bearings. This type of bearing includes ball, roller, and needle bearings. Each of these sub-types emphasizes certain envelope and operational characteristics. Table 201-VII highlights a number of parameters to be used in selecting between anti-friction and plain bearings and in selecting the optimum anti-friction bearing. Figure 201-3 is a guide which aids in the selection of a specific standard anti-friction bearing. See also tables 201-I, 201-II, and 201-III.

4.1.2 Plain bearings. Figure 201-4 is matrix of the available standard plain journal bearings and plain spherical bearings. It is intended for use in making a selection of a plain bearing for a specific application in conjunction with tables 201-IV and 201-V.

4.2 Selection for systems application. Optimum selection of a bearing for a system application is often dictated by the unique set of requirements imposed on the bearing by the specific system function.

4.2.1 Primary control systems. These systems utilize numerous bearings in the control surface positioning mechanisms. Due to the possibility of friction build up, emphasis should be placed on anti-friction bearings per requirement 206. Primary control surface hinge and support bearings do not have such critical friction requirements. Accordingly, plain bearings should be considered to minimize weight and envelope penalties. The unit dynamic loading on these bearings must be kept sufficiently low to obtain design life. Rod end bearings used in control rods shall be meet this requirement and requirement 207.

4.2.2 Secondary and auxiliary control systems. Bearings used in these systems shall be subject to the limitations of this requirement and requirement 207.

4.2.3 Landing gear. Bearings used in aerospace vehicle landing gear can be functionally categorized into:

- a. Structural bearings to transfer major loads between the gear and the vehicle structure, such as trunnion bearings.
- b. Bearings, other than major load-carrying bearings, which maintain the gear in the appropriate deployed position. These include end attach bearings on side struts and drag struts.
- c. Landing gear actuation mechanism bearings.

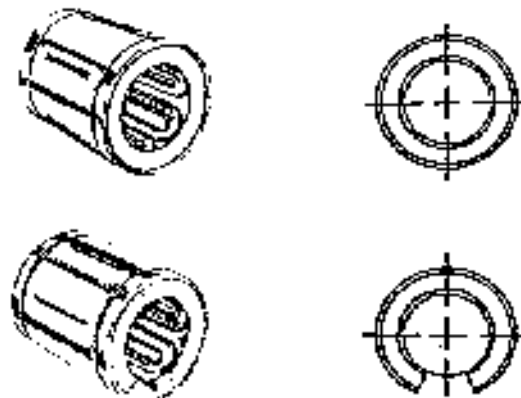


FIGURE 201-1. Linear motion ball bearings

MIL-HDBK-1599A

REQUIREMENT 201

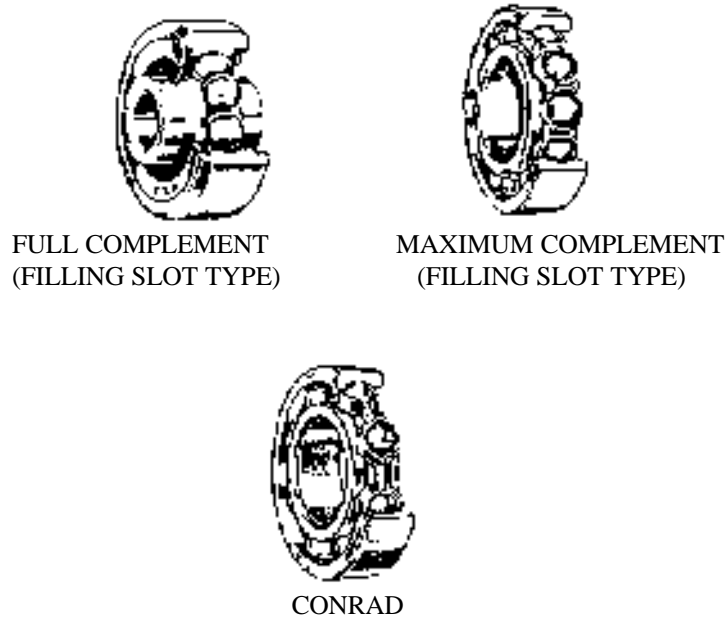


FIGURE 201-2. Annular ball bearings

4.2.3.1 The above first two categories of bearings normally carry very high loads while in an essentially “static” situation. Bearing rotation is that due to structural deflection but loads are high, of an impact nature, and often reversing. The same bearings must permit sufficient rotation to permit gear extension and retraction. Loads during actuation are due primarily to only the gear weight plus air loads and are commonly about ten percent of the "static" loads. Plain bearings function well in these applications and, where sufficient space is available, anti-friction roller bearings may also be used.

4.2.3.2 Landing gear actuation mechanism bearings should be isolated from the primary load paths in the gear. This permits bearing selection and sizing based only on the actuation loads. Bearing selection is based on the same considerations as in other actuation systems. Plain bearings and anti-friction roller bearings are both suitable.

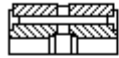
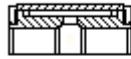
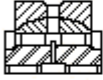


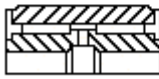
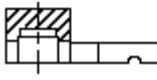
4.2.4 Flaps and spoilers. Bearing loading in these applications differs from landing gear bearing loading in that maximum loading occurs while these surfaces are deployed into the slip stream. Accordingly, the static and dynamic loading of the bearings is quite close and bearing selection is based on bearing life under dynamic loading. Hinge, support, and actuation mechanisms use bearings of the plain or, (on occasion) anti-friction roller bearings for these applications. Most flap systems use structural tracks to deploy the flaps with the flaps attached to the tracks with a flap carriage. Flap carriage bearings require high load capacity, minimum envelope, and low friction. Track roller bearings should be used for such applications.

4.3 Selection based on bearing characteristics. Selection of the proper bearing for an aerospace vehicle application requires consideration of a number of specific bearing functional characteristics. These include friction, torque, temperature capabilities, static and dynamic load capabilities, and rotational and alignment capabilities

MIL-HDBK-1599A

REQUIREMENT 201









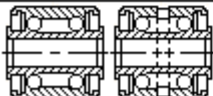

TABLE 201-I. Typical needle bearings.

Illustration	Typical Service	Bore size Range	Series	Military Standard
	Heavy Duty	0.1900 thru 5.0000	NBC	MS24461
	Extra-light Duty Oscillation	0.1900 thru 1.2500	NCC	MS24462
	Heavy Duty Self-Aligning Single row	0.1900 thru 0.3125	NBE	MS24463
	Heavy Duty Self-aligning Double Row	0.3750 thru 3.5000	NBK	MS24464
	Track Roller Single Row	0.1900 thru 2.7500	NBF	MS24465
	Track Roller Double Row	0.3750 thru 2.0000	NBL	MS24466
	Track Roller Single Row	Stud Diameter 0.1900 thru 0.5000	HRS	MS21432

MIL-HDBK-1599A

REQUIREMENT 201

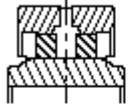
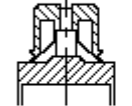
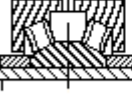
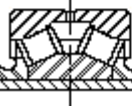
TABLE 201-II. Typical ball bearings.

Illustration	Typical Service	Bore Size Range	Series	Military Standard
	Heavy Duty	0.1900 thru 0.6250	KP	MS 27640
	Light Duty	0.1900 thru 1.2500	KP-A	MS 27641
	Light Duty	1.3130 Thru 3.0630	KP-B	MS 27642
	Heavy Duty Self-Aligning	0.1875 thru 0.6250	DSP	MS 27643
	Extra Heavy Duty	0.1900 thru 0.6250		MS27644
	Light and Heavy Duty Self-Aligning	0.1900 thru 0.6250	KSP KSP-A	MS 27645
	Extra Light Duty	thru 2.3125	H15000D	MS 27646 MS 21428
	Extra Light Duty Self-Aligning	1.0000 thru 3.0610	KP-BS	MS 27468
	Intermediate Duty Extra Wide	0.2500 thru 0.5000	DW GDW	MS 27647
	Intermediate Duty	0.1900 thru 1.2500	AVWAK	MS 27649

MIL-HDBK-1599A

REQUIREMENT 201


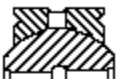





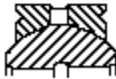
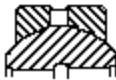
TABLE 201-III. Typical roller bearings.

Illustration	Typical Service	Bore Size Range	Series	Military Standard
	Extra light duty, self-aligning torque tube	1.0000 to 3.0630	DAT	MS28915
	Self-aligning, intermediate duty	0.1900 to 0.5000	SA	MS21431
	Self-aligning, heavy duty, high thrust	0.2500 to 0.7500	DAS	MS28913
	Self-aligning, extra heavy duty, high thrust	0.2500 to 0.8700	DAS	MS28914

MIL-HDBK-1599A

REQUIREMENT 201

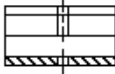
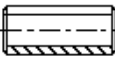
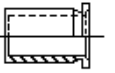
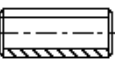
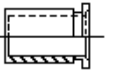
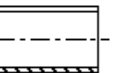
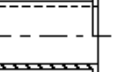
TABLE 201-IV. Typical spherical type bearings

ILLUSTRATION	TYPICAL SERVICE	BORE SIZE RANGE	SERIES & MATERIALS	STANDARD
	Infrequent oscillation or misalignment, heavy loads	0.1900 to 1.0000	Narrow series steel ball and race, grease lubricated	MS 21155
	Intermittent oscillation or misalignment light to medium loads		Narrow series steel ball and race, grease lubricated	MS21154 (Grooved outer race for staking)
		0.1900 to 1.0000	Narrow series CRES ball and race teflon lined	MS 14104
			Wide series CRES ball and race teflon lined	MS 14102
			Narrow series CRES ball and race TFE lined	MS 14101
			Wide series CRES ball and race TFE lined	MS 14103
				
		0.2500 to 1.5000	Narrow series grooved ring. BeCu ball CRES race	M81936/1
			Narrow series BeCu ball CRES race	M81936/2

MIL-HDBK-1599A

REQUIREMENT 201

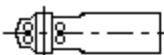

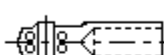
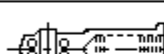
TABLE 201-V. Journal bearings and bushings.

ILLUSTRATION	TYPICAL SERVICE	BORE SIZE RANGE	SERIES and MATERIAL	STANDARDS
	Clamp up on shaft heavy static loads, little movement	0.1900 to 1.0000	Steel 4130 chrome plated on O.D.	NAS 72
	Clamp up on shaft heavy static loads, little movement	0.1900 to 1.0000	Steel 4130 cadmium plated all over	NAS 73
	Clamp up on shaft medium static loads, little movement	0.1900 to 1.0000	Bronze, Aluminum	NAS 74
	Press fit, medium static loads, little movement	0.1900 to 1.2500	Steel, cadmium plated	NAS 75
	Press fit, medium static loads, movement on I.D. of bushing	0.1900 to 1.2500	Bronze, Aluminum (cadmium plated)	NAS 76
	Press fit, heavy static loads (steel), medium static loads and medium oscillating loads (bronze)	0.1900 to 1.2500	Steel (cadmium plated) Bronze (cadmium plated)	NAS 77
	Press fit, inside undersized for reaming. Heavy static loads (steel). Medium static and medium oscillating loads (bronze)	0.1790 to 1.2190	Steel (4130) (cadmium plated) or Bronze, Aluminum (cadmium plated)	NAS 538
	Press fit, inside undersized for reaming. Heavy static loads (steel). Medium static and medium oscillating loads (bronze)	0.1790 to 1.2190	Steel (4130) (cadmium plated) or Bronze, Aluminum (cadmium plated)	NAS 538
	Movement between bearing bore and shaft. Can handle fretting conditions. Radial load only	0.2515 to 2.0015	Aluminum or CRES shell. Teflon lining	MS81934/1
	Movement between bearing bore and shaft. Can handle fretting conditions. Radial load and thrust load in one direction	0.2515 to 2.0015	Aluminum or CRES shell. Teflon lining	MS81934/2



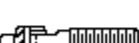
MIL-HDBK-1599A

REQUIREMENT 201



TABLE 201-VI. Rod end bearings.

Ball Bearing Rod Ends				
ILLUSTRATION	TYPICAL SERVICE	BORE SIZE RANGE	TYPE	STANDARD
	Low to medium static loads, medium dynamic radial and thrust load	0.1900 to 0.2500	Self-aligning ball bearings, solid shank	MS 21150
	Low to medium static loads, medium dynamic radial and thrust load	0.1900 to 0.2500	Self-aligning ball bearings, externally threaded shank	MS 21151
	Low to medium static loads, medium dynamic radial and thrust load	0.1900 to 0.2500	Self-aligning ball bearings, hollow shank	MS 21152
	Low to medium static loads, medium dynamic radial and thrust load	0.1900 to 0.2500	Self-aligning ball bearings, internal threaded	MS 21153

Roller Bearing Rod Ends				
	Medium static loads, light thrust and radial dynamic loads	0.2500 to 0.3750	Roller bearing self-aligning externally threaded shank	MS 1233 (MIL-B-8952)
	Medium static loads, medium thrust and radial dynamic loads	0.2500 to 0.3750	Roller bearing self-aligning internally threaded shank	MS 1233 (MIL-B-8952)
	Medium static loads, medium thrust and radial dynamic loads	0.2500 to 0.6250	Roller bearing self-aligning externally threaded shank	MS 1233 (MIL-B-8952)

Plain Spherical Bearing Rod Ends				
	High static loads medium dynamic and thrust loads	0.1900 to 1.0000	Plain bearing TFE lined externally threaded shank	MIL-B-81935/2
	High static loads medium dynamic and thrust loads	0.1900 to 1.0000	Plain bearing TFE lined externally threaded shank	MIL-B-81935/1

MIL-HDBK-1599A

REQUIREMENT 201

**TABLE 201-VII Bearing selection parameters**

OPERATING PARAMETER	ROLLING ELEMENT			SLIDING ELEMENT BEARINGS	
	BALL BEARINGS	NEEDLE BEARINGS	ROLLER BEARINGS	TFE LINED BEARINGS	METAL TO METAL BEARINGS
<b>LOAD CAPACITY</b>					
(For a given Envelope size)	Low	Medium	Medium	Medium	High
Radial (Static)	Low		Medium	Medium	High
Axial (Static)	Low		Low	Medium	High
Shock	Low		Medium	Medium	High
Vibration	Rapid Fretting	Moderate Fretting	(Preloading Helps) Rapid Fretting (Preloading Helps)	Medium	High
<b>TYPE OF OPERATION</b>					
Small Oscillation	Possible Fretting	Best of Rolling Element	Possible	Handle Well	Reversed Loading Required
Oscillation	Good	Good	Good	Good	Reversed Loading Required
Slow Rotation	Good	Good	Good	Limited by Surface Speed	Excellent
<b>SPEED</b>					
High Speed Oscillation (Continuous)	Excellent with Cages	Excellent with Cages	Excellent with Cages	Excellent with small angles	Poor
High Speed Oscillation (Intermittent)	Excellent	Excellent	Excellent		Requires Average Loading
High Speed Rotation (Continuous)	Excellent with Cages	Not Intended	Excellent with Cages	Do Not Use	(TBD)
High Speed Rotation (Intermittent)	Excellent with Cages	Not Intended	Excellent with Cages	Consult Standards	(TBD)
High acceleration	Requires preload	Not Intended	Requires preload	Good	Good
<b>DUTY CYCLE</b>	No Effect	No Effect	No Effect	May cause heat	May cause heat
<b>TEMPERATURE</b>					
Continuous	Dependent on Grease Seals and material.-65 F to 350 F for Stds	Dependent on Grease Seals and material.-65 F to 350 F for Stds	Dependent on Grease Seals and material.-65 F to 350 F for Stds	-65 F to 350 F	Dependent on material and lube
Maximum				375 F	Dependent on material expansion
Minimum				High increase in friction	Good
<b>MISALIGNMENT</b>	Decrease in capacity	Can not tolerate	Good	Good	Good
<b>COEFFICIENT</b>	0.0015	0.0025	0.002	Dependent on load and temperature 0.03 -0.10	0.2
<b>POSITION ACCURACY</b>	Dependent on Internal Clearance	Dependent on Internal Clearance	Dependent on Internal Clearance	Changes with wear	Approximate 0.001 Initially Changes with wear
<b>ENVIRONMENTAL</b>					
Conditions Dirt, Water, Contaminates Phosphate Eater Fluids Vacuum	Permanently Sealed No problems with MS Outgas of lube	(TBD) (TBD) Outgas of lube	Sealed and purged with lube Outgas of lube	Increased wear rate Increased wear rate Increased wear rate No effect	Purged with lube No effect Outgas of lube
<b>REQUIRED LIFE</b>					
Shelf Service	Dependent on lube limited by wear, galding, seizing and fretting	Dependent on lube limited by wear, galding, seizing and fretting	Dependent on lube limited by wear, galding, seizing and fretting	Excellent Limited by wear	Dependent on lube and load
<b>RETENTION METHODS</b>	Stake housing	Strake housing	Stake housing	Stake housing or BRG	Stake housing or BRG
<b>MAINTENANCE</b>	Permanently packed	Relubrication required	Relube for high loads	Self lubricating	Relubricate often
<b>PRESURE DIFFERENTIAL</b>	May purge	May purge	May purge	No problem	No problem
<b>STIFFNESS</b>	Low	Medium	Medium	(TBD)	High

NOTE: Many of the above parameters are highly dependent on the application. Therefore the information should be used only as a guide toward the initial selection.

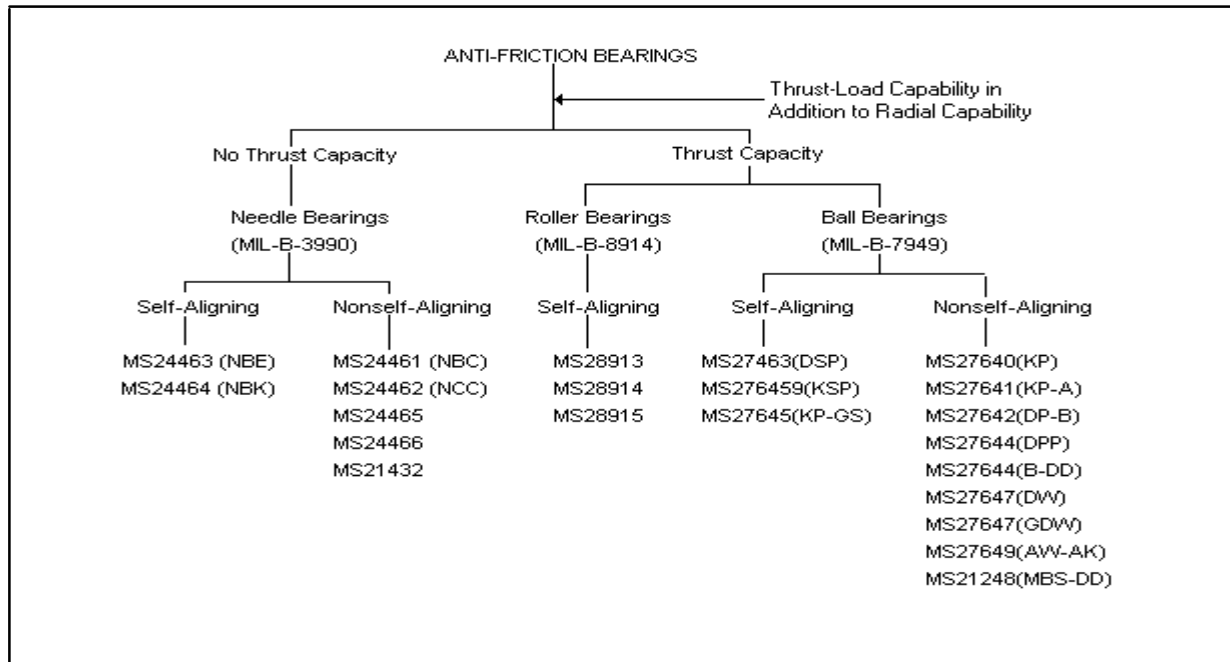


FIGURE 201-3. Standard Anti-Friction Bearing Selection Matrix

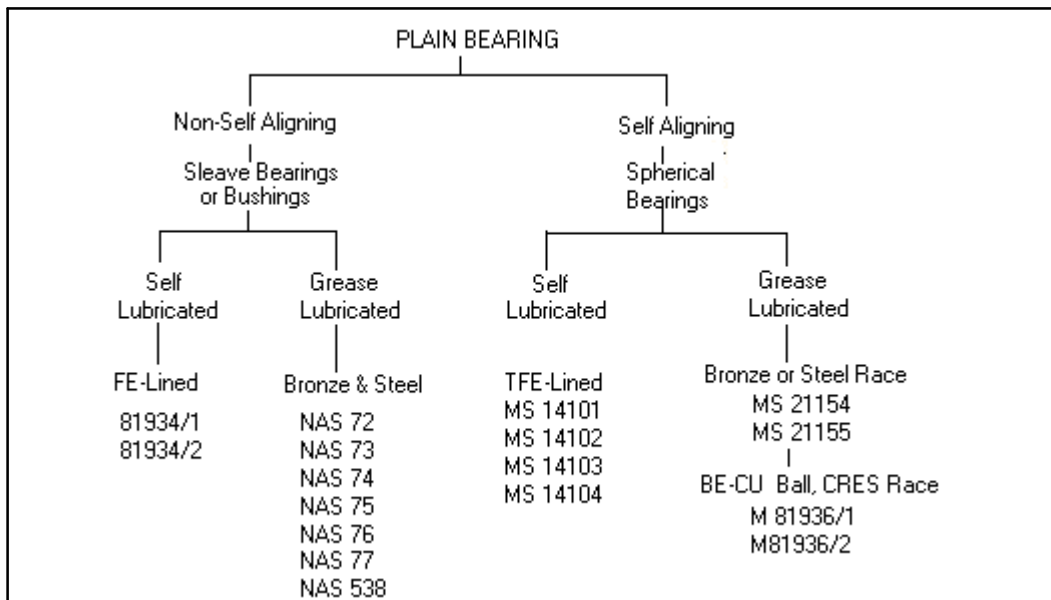


FIGURE 201-4. Plain bearing standard selection matrix (see requirements 306, 307, 309 and 310).

4.3.1 Friction. Airframe anti-friction full type bearings may be considered to have a running coefficient of friction of 0.0025. A conservative value for caged ball bearings is 0.0015. Use a value of 0.0025 for needle complement track rollers and 0.002 for roller bearings. Table 201-VII includes representative friction coefficient values. Properly lubricated metal-to-metal plain bearings, both spherical and journal, operate with a friction coefficient varying between 0.10 and 0.30. The low figure relates to reverse loading and considerable motion, while the higher value occurs with heavy, unidirectional loading and relatively slow motion. A coefficient of 0.20 is a reasonably conservative value for most design work. TFE fabric lined plain bearings may be considered to have a friction coefficient of .03-.10. The coefficient decreases for TFE with increases in temperature and load. The increase at low temperatures is considerable and adequate allowances must be made in design. If a design requires lower friction than is indicated above for proper functioning, it may be necessary to use special bearings with variations in materials, lubricants, internal geometry, or sealing techniques. Such special bearings require approval per requirement 101.

4.3.2 Torque. The coefficient of friction of a bearing is an indirect measure of the bearing's resistance to rotation. As such, the designer needs certain information on bearing internal geometry to make the necessary calculations. A more direct approach is to work with torsional resistance or torque.

4.3.2.1 Anti-friction bearings. At normal temperatures, these bearings introduce relatively little frictional torque into control system mechanisms. The running torque of a grease lubricated anti-friction bearing under load at moderate temperature can be estimated from the formula.

$$T = \mu_f R F_r \text{ where}$$

$$T = \text{torque, inch pounds}$$

$$\mu_f = \text{friction coefficient (see 4.3.1 and table 201-VII)}$$

$$R = 1/2 \text{ bearing bore, inches}$$

$$F_r = \text{radial load, pounds}$$

At low temperature and light load, a large portion of the torque generated by the bearing is due to the resistance of the grease. Another large portion of the torque is due to seal drag. Figures 201-6 and 201-7 show the no-load starting and running torque of a number of standard bearings. Values are shown for a temperature range of -65°F to 70°F.

$$T_T = T + T_{NL}, \text{ where}$$

$$T_T = \text{torque at desired temperature, inch pounds}$$

$$T = \text{torque at } 70^\circ\text{F, inch pounds}$$

$$T_{NL} = \text{no load torque at desired temperature, inch pounds, (from figure 201-6)}$$

The torque values shown in figures 201-5 and 201-6 are average, values from limited test data. Values for individual bearings in specific applications will show significant scatter based on the grease used, the amount and distribution of the grease, effect of seals, bearing source, and the installation fit and retention

method. A comparison of the low temperature properties and characteristics of several greases can be found in requirement 203. The values from the figures will give realistic frictional torque values for a complete system. For those instances where only one or two bearings are involved, the torque values in the figures should be multiplied by the factors listed with the figures. These factors represent the maximum scatter experienced in testing. For operating speeds significantly higher than the bearing peripheral speed of one inch per second, the frictional torque values computed should be multiplied by a speed factor obtained from figure 201-7.

#### 4.3.2.2 Plain bearings.

4.3.2.2.1 The torque of plain bearings varies more than that of rolling element bearings. Friction coefficients of the sliding surface in these bearings vary with speed and load, and in the case of TFE-lined and grease-lubricated bearings vary markedly with temperature. It is possible to estimate average torque for these bearings at various loads at room temperature by the following formula:

$$T + \mu_f R_f$$

where

T = torque, in. lb.

$\mu_f$  = friction coefficient from paragraph 4.3.1

$F_r$  = radial load, lbs.

R = one-half of diameter in inches (use ball diameter for spherical bearings turning on ball; use bore diameter for plain bearings-and spherical bearings turning on bore).

4.3.2.2.2 Friction coefficients for TFE-lined plain bearings at various temperatures and stress levels are shown in figure 201-8, which is based on average values obtained in tests of journal bearings.

4.3.2.2.3 The frictional torque in standard beryllium copper ball/stainless steel race bearings varies significantly with the type and amount of grease in the bearing. With no lubrication the friction coefficient can be as high as 0.54 and varies linearly with applied load. Clean, well-lubricated bearings show friction coefficients between 0.01 and 0.10. For these bearings lubricated with MIL-G-81322 or MIL-G-23827 grease, between -65°F and 300°F, and operating within the established load ratings, a conservative friction coefficient value of 0.20 should be used.

4.3.3 Temperature capability. All bearings used in an aerospace vehicle design shall be capable of functioning within the appropriate ambient temperature range specified in the design contract. Where variations exist from the specified ambient temperature range in specific applications, other factors must be considered. These include the maximum temperature exposure, duration of exposure, percent of bearing load rating while exposed, and amount of bearing motion during the extreme temperature exposure. If it is apparent that the standard bearing cannot function properly in an extreme situation, a special bearing is required. The following ground rules shall be applied in establishing the design of the special bearing:

MIL-HDBK-1599A

REQUIREMENT 201

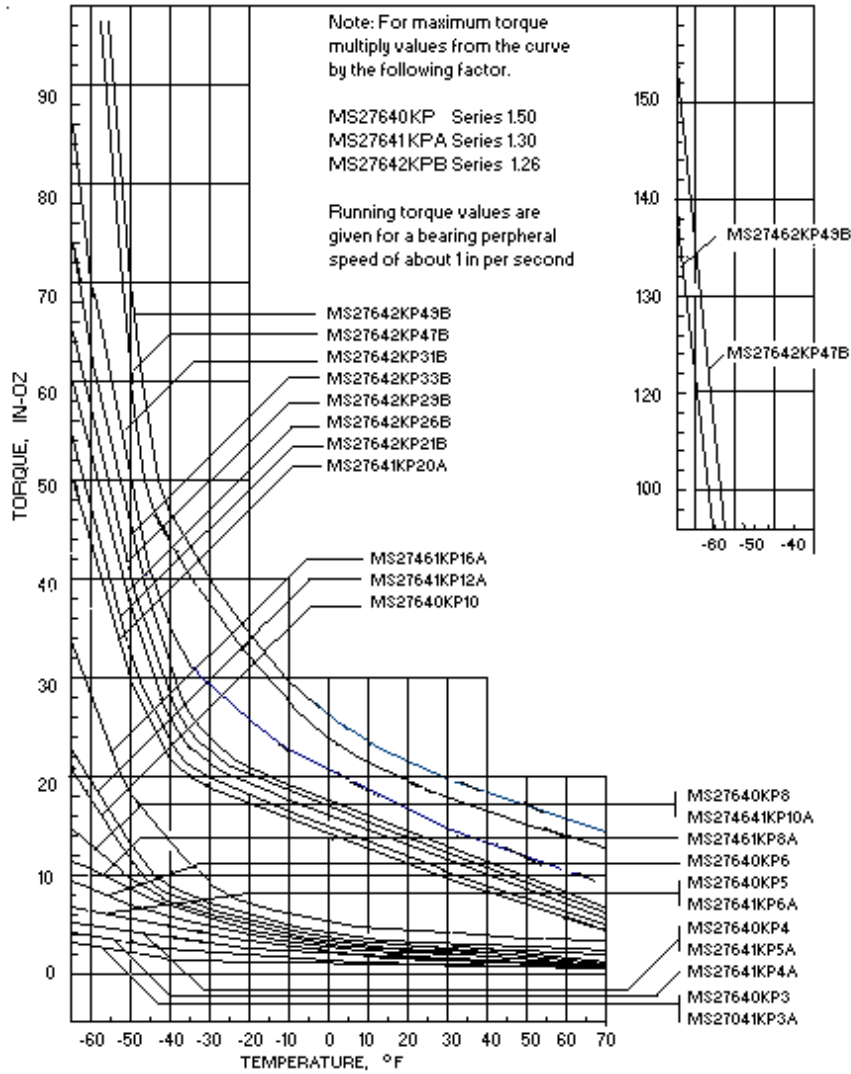


FIGURE 201-5. Average no load starting torque.

MIL-HDBK-1599A

REQUIREMENT 201

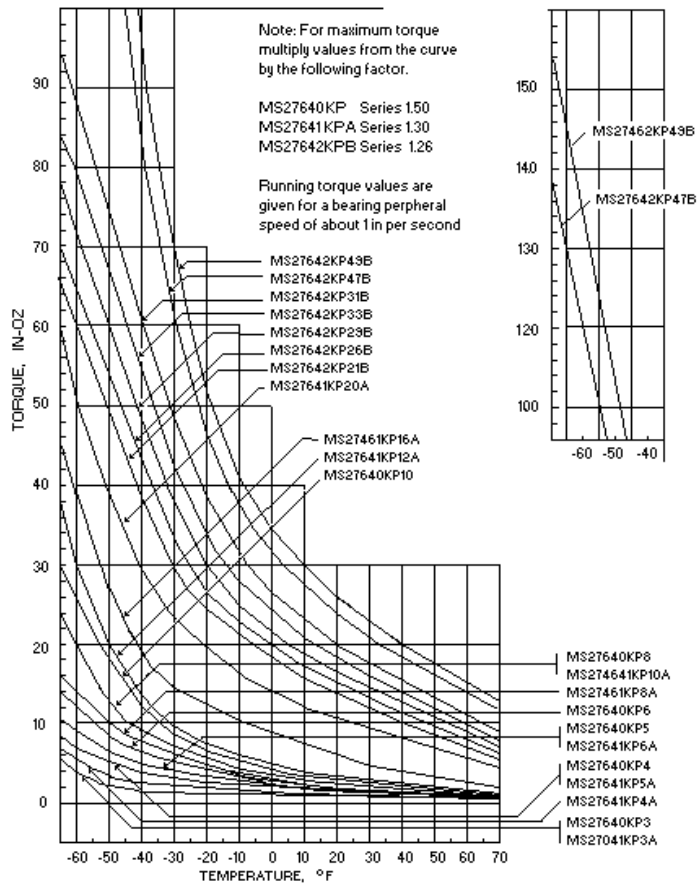


FIGURE 201-6. Average no load running torque.

MIL-HDBK-1599A

REQUIREMENT 201

- a. It is desirable to continue with MS envelope and basic design if practicable.
- b. Special bearings must be approved to requirement 101.
- c. Materials recommended for bearings intended for extreme temperature use are shown in requirement 104.

4.3.4 Load capacity. Two primary load conditions must be considered to properly select a bearing for an aerospace vehicle application. "Static" loading is concerned with the strength of the bearing and its ability to resist significant deformation and fracture. "Dynamic" loading is concerned with the oscillation or rotation of the bearing while under fixed or changing load and is limited by fatigue and wear.

4.3.4.1 Anti-friction bearings.

4.3.4.1.1 Ball bearings.

4.3.4.1.1.1 Static capacity. Static limit load capacities are shown on the approved standards included in requirement 301. The radial static limit load (SLR) ratings for ball bearings are based on the formula:

$$SLR = K N D^2$$

where

K = design factor

N = number of balls

D = ball diameter, in.

Figures 201-9 and 201-10 can be used in comparing standard ball bearings capacities on the basis of bore and outside diameter dimensions to aid in bearing selection. Allowable K factors are 10,000 for deep groove bearings, 4800 for single-row self-aligning bearings, 3800 for double-row self-aligning bearings, and 3200 for rod-end bearings. The static limit load can be applied to the bearing for a short period of time without affecting the smooth operation or endurance under the normal loads and oscillatory motion encountered in airframe applications. The minimum static fracture load (where an actual breakage of the bearing occurs) is not less than 1.5 times the static limit load. Axial static capacity varies from approximately 50% to 60% of radial capacity for nonself-aligning ball bearings and 13% to 20% for self-aligning types. These bearings cannot take full rated radial and thrust limit loads simultaneously. The combined loading situation is covered later in this requirement.

MIL-HDBK-1599A

REQUIREMENT 201

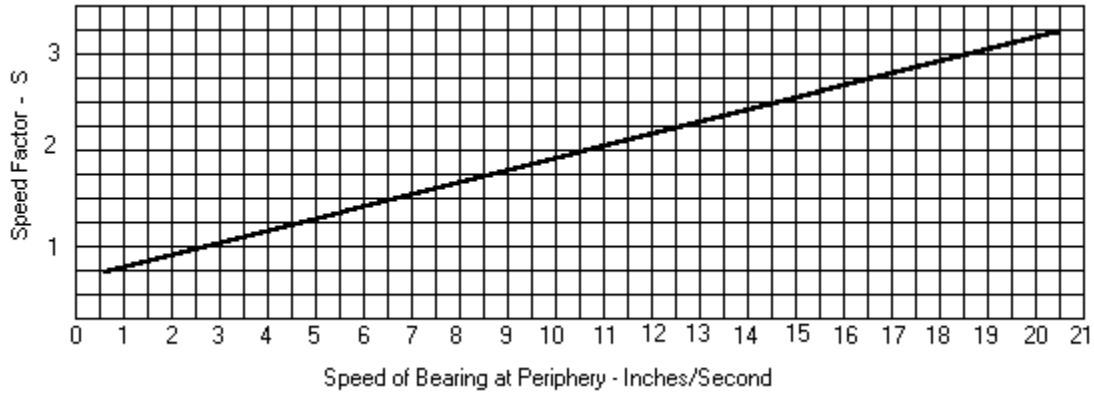
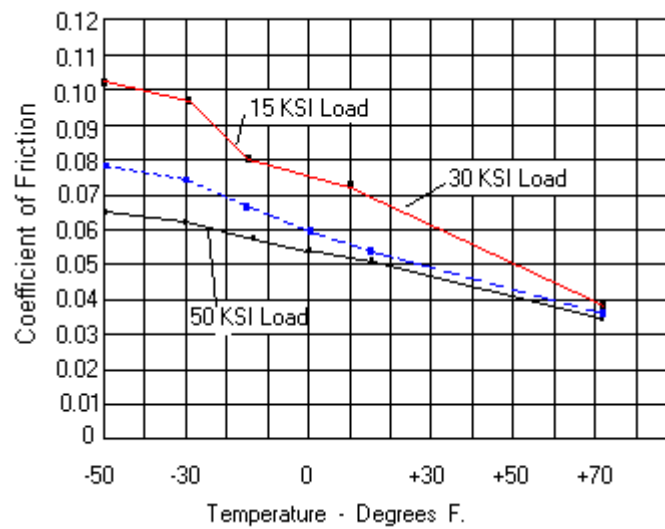


FIGURE 201-7. Bearing friction speed factor.



Mating Surface: Polished pH 13-8 Steel, Cond. H-1000,  
 4-5 RHR Surface Finish  
Speed = 0.82 Lineal Feet Per Minute

FIGURE 201-8. Effect of temperature and unit load on friction coefficient of TFE liner.

MIL-HDBK-1599A

REQUIREMENT 201

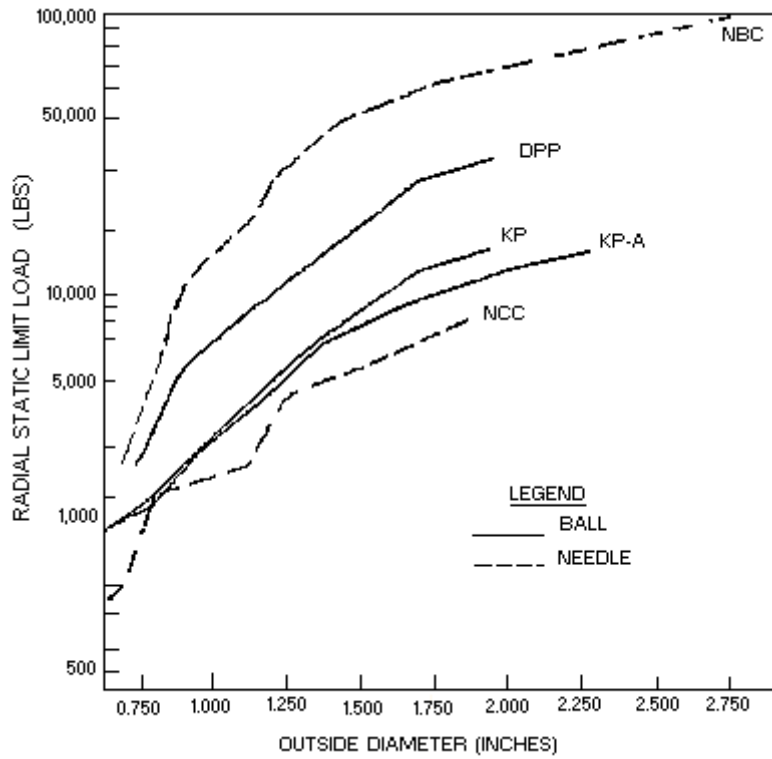


FIGURE 201-9. Static limit load ratings for anti-friction control-type bearings.

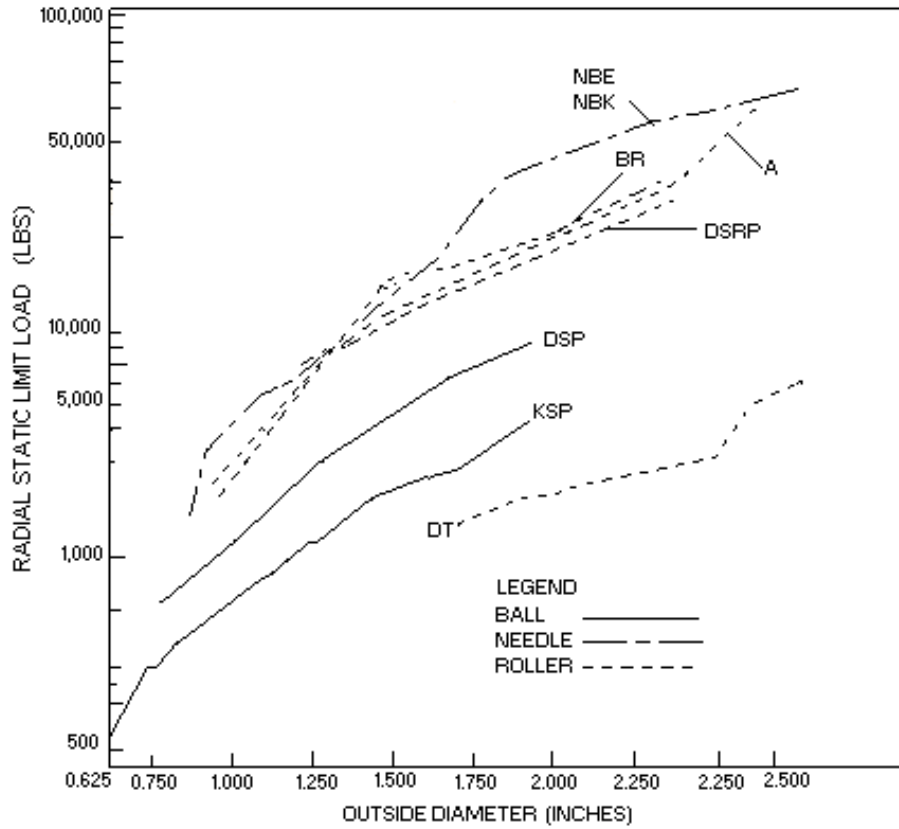


FIGURE 201-10. Static limit load ratings for anti-friction control-type bearings, self-aligning.

MIL-HDBK-1599A

REQUIREMENT 201

4.3.4.1.1.2 Dynamic capacity. The basic dynamic capacity of an airframe ball bearing is the constant radial load at which 90% of a group of identical bearings running at the same speed, temperature and angle of oscillation will meet or exceed a fatigue life of 2000 revolutions. An oscillatory cycle, through an angle of at least the ball spacing, is considered equivalent to a revolution. If a bearing life of more than 2000 cycles or revolutions is required, the applied constant radial load must be reduced to a value below the basic dynamic capacity of the bearing. The dynamic capacity of an airframe ball bearing is related to the cyclic life by the following formula.

$$C = \frac{C_o}{L}$$

where

C = dynamic capacity desired

C<sub>o</sub> = basic dynamic capacity at L<sub>10</sub> = 2000 revs. (equals average life of 10,000 cycles)

L = life factor from figure 201-11, which is based on the formula

$$L = \left( \frac{n}{2000} \right)^{\left( \frac{1}{3.6} \right)},$$

where

n = desired bearing life

The basic dynamic capacity is based on the inner race moving and the outer race stationary. If the reverse is true, reduce the basic dynamic capacity by dividing by a factor of 1.20.

4.3.4.1.1.3 Equivalent loading. If the magnitude of the load applied to the bearing varies greatly, a constant mean load which has the same influence on bearing life must be computed to permit proper sizing of the bearing. In this instance, the following rules apply:

- a. If load magnitude varies less than 30%, use the high load value.
- b. If greater variation in load magnitude occurs, use an estimated load somewhat higher than the arithmetic average, taking into account the relative percentage of total life at each significant load level.
- c. If a more exact load figure is desired, the variable dynamic load magnitudes may be stepped off to a number of incremental load values associated with a finite proportion of total bearing life and used in the equation:

MIL-HDBK-1599A

REQUIREMENT 201

$$P = \left[ \frac{N_1 (P_1)^{3.6} + N_2 (P_2)^{3.6} + \dots + N_n (P_n)^{3.6}}{N} \right]^{\frac{1}{3.6}},$$

where

P = equivalent dynamic load to result in the same life as the variable loads

N = N<sub>1</sub> + N<sub>2</sub> + ... N<sub>n</sub> = total cycles or revolutions

P<sub>1</sub> = load acting during N<sub>1</sub> revolutions

P<sub>2</sub> = load acting during N<sub>2</sub> revolutions

P<sub>n</sub> = load acting during N<sub>n</sub> revolutions

4.3.4.1.1.4 Moment loading. In some cases a moment or overturning load is present in an airframe bearing application. This moment loading should not exceed the limit moment rating given for each non-aligning bearing in the MS series. Self-aligning bearings are not designed to carry any moment loading. See table 201-VIII for limit moment ratings.

4.3.4.1.1.5 Combined loading. An airframe control bearing frequently is applied such that it must carry loads composed of axial as well as radial components. It is then necessary to convert these loads into a so-called equivalent load. An approximation for combining radial and thrust loads for either static or dynamic conditions can be obtained from the formula:

$$P = F_r + YF_t, \text{ where}$$

P = the equivalent load

F<sub>r</sub> = the applied radial load

F<sub>t</sub> = the applied thrust load

Y = a thrust factor =  $\frac{\text{radial load rating}}{\text{thrust load rating}}$

MIL-HDBK-1599A

REQUIREMENT 201

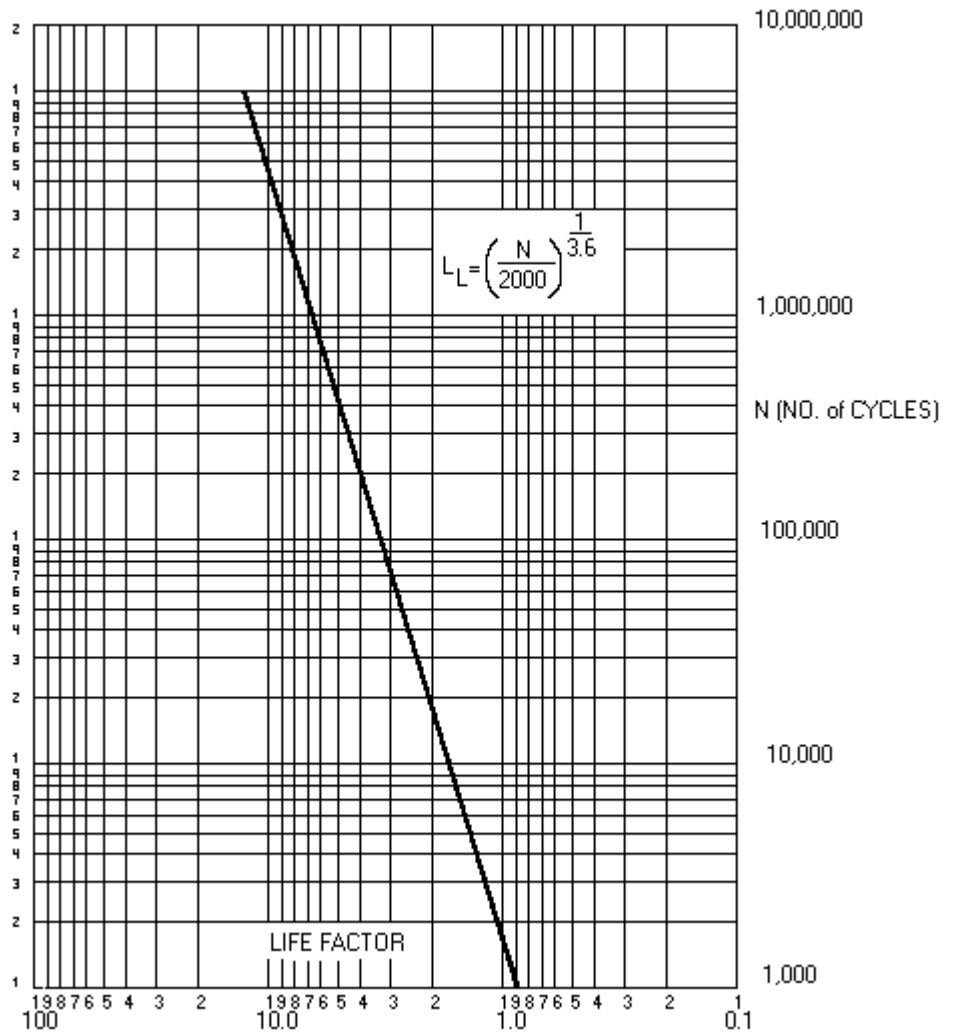


FIGURE 201-11. Life factors for ball bearings.

MIL-HDBK-1599A

REQUIREMENT 201

TABLE 201-VIII. MS ball bearings limit moment ratings.

Bearing	Limit Load Moment Rating Inch-Lbs	Moment Constant K $\eta$ ( J/Inch)
M327640-3A	58.0	12.10
MS27640-3	88.7	10.10
MS27640-4	136.0	8.85
MS27640-5	370.0	6.76
MS27640-6	644.0	5.44
MS27640-8	1170.0	4.46
MS27640-10	1520.0	4.09
MS27641-3	49.6	12.10
MS27641-4	88.6	10.20
M327641-5	114.0	8.75
MS27641-6	143.0	7.68
MS27641-8	227.0	6.15
MS27641-10	598.0	5.02
MS27641-12	945.0	4.13
MS27641-16	1600.0	3.25
MS27641-20	2170.0	2.81
MS27642-16	444	3.60
MS27642-21	1480	2.96
MS27642-23	1700	2.76
MS27642-25	1930	2.60
MS27642-29	2420	2.31
MS27642-33	3150	2.03
MS27642-37	3780	1.85
MS27642-47	6880	1.45
MS27642-49	8520	1.42
MS27642-52	TBD	TBD
MS27642-56	TBD	TBD
MS27642-60	TBD	TBD
MS27642-64	TBD	TBD
MS27642-68	TBD	TBD
MS27642-72	TBD	TBD
MS27642-76	TBD	TBD
MS27642-80	TBD	TBD
MS27642-84	TBD	TBD
MS27642-88	TBD	TBD
MS27642-92	TBD	TBD
MS27642-96	TBD	TBD

MIL-HDBK-1599A

REQUIREMENT 201

TABLE 201-VIII. MS ball bearings limit moment ratings. - Continued

Bearing	Limit Load Moment Rating Inch-Lbs	Moment Constant K $\eta$ (l/Inch)
MS27644-3	38.3	44.4
MS27644-4	90.9	19.8
MS2T644-5	56.3	71.0
MS27644-6	278.0	19.0
MS27644-8	590.0	13.2
MS27644-10	1600.0	5.88
MS27646-38	255	5.89
MS27646-39	329	5.16
MS27646-40	414	4.59
MS27646-41	567	3.88
MS27646-42	825	3.27
MS27646-43	1130	2.83
MS27646-44	1470	2.44
MS27646-45	1890	2.12
MS27646-46	2290	1.92
MS2764T-4A	129	3.88
MS27647-4	.392	2.30
MS27647-5	882	1.81
MS27647-6	2010	1.29
MS27647-8	4860	.967
MS27649-3	28.3	10.6
MS27649-4	41.2	9.72
M327649-5	72.3	8.29
MS27649-6	80.5	7.45
MS27649-8	170.0	5.85
MS27649-10	286.0	4.89
MS27649-12	456.0	3.94
MS27649-16	706.0	3.12
MS27649-20	995.0	2.71

The equivalent load should be equal to the applied radial load, if the applied thrust load does not exceed 10% of  $F_r$ . The equivalent load calculated shall never be greater than the bearing rating in either the static or dynamic condition. A more general and accurate formula for computing the equivalent load is

$$P = XVFF + YF_t, \text{ where}$$

the notation is as above, and

X = a radial factor

V = a rotation factor, 1.0 for inner ring rotation and 1.2 for outer ring rotation

MIL-HDBK-1599A

REQUIREMENT 201

For standard MS airframe control bearings, X and Y factors are as follows:

Military Standard	X	Y
MS27640	1.00	3.00
MS27641	1.00	3.00
MS27642	1.00	3.00
MS27643	0.65	3.70
MS27644	0.50	1.69
MS27645	0.40	4.57

NOTE: In no instance shall the calculated equivalent load be greater than the bearing rating.

4.3.4.1.2 Roller bearings. This section is concerned with aircraft control roller bearings using either concave or convex rollers. Such bearings are covered by requirement 302. Commercial and tapered roller bearings are not within the scope of this requirement. The several load ratings shown on the military standards, and covered herein, include limit load, dynamic load, and ultimate load ratings. They are applicable to loading in either the radial or axial directions. The load ratings essentially represent demonstrated bearing capacities, factored to provide appropriate safety margins.

4.3.4.1.2.1 Static capacity. The basic static load capacity of a roller bearing is termed the limit load rating. This is the maximum load which the bearing can carry without subsequently affecting performance to the rated life at the dynamic load rating. If the limit load rating is exceeded, the life of the bearing is no longer predictable. The static limit load rating of both single-row and double-row concave and convex roller bearings is given by the formula:

$$SLR = 12000NDL \cos \alpha \text{ where,}$$

SLR = static limit load rating, lb.

N = the number of rollers

D = the mean roller diameter, in.

L = the roller contact length, in.

$\alpha$  = the roller inclination angle to the bearing bore axis, degrees

The above formula provides the radial rating for the bearing. The axial capacity ranges from 10% of the radial capacity for single row bearings to 72% for certain of the wide series double row bearings. The ultimate load rating, also a function of the limit load rating, is defined as the load which can be applied and held for three minutes without structural failure of the bearing. Actual fracture usually occurs at a load level substantially higher than the ultimate load rating. The ultimate load rating is calculated as the limit load rating multiplied by a factor of 1.5. In application, brinelling will occur on the race surface if subjected to a load equal to the ultimate load rating. The bearing will still be operative even though the races may be brinelled, but the bearing should be replaced

MIL-HDBK-1599A

REQUIREMENT 201

4.3.4.1.2.2 Dynamic capacity. The basic dynamic capacity of a roller bearing is termed the dynamic load rating. The dynamic load rating is defined on the basis of a unidirectional load that will result in an average bearing life ( $L_{50}$ ) of 10,000 cycles at  $90^\circ$  oscillation before evidence of contact fatigue (spalling) occurs. The angle of oscillation is defined at  $180^\circ$  of angular travel within an included arc of  $90^\circ$ . The load/life relationship for roller bearings is shown in figure 201-11. The dynamic load rating for roller bearings is that load which results in an average life ( $L_{50}$ ) of 10,000 cycles at  $90^\circ$  oscillation. In most aerospace operations, the dynamic (applied) operating load is much less than the rated load for the bearing. It is then necessary to determine bearing life based on the applied load. The load/life equation listed below can be used to calculate bearing life at any load ( $P_e$ ). Average bearing life ( $L_{50}$ ) signifies that 50% of a given group of bearings will survive 10,000 cycles, at the rated dynamic load. In cases where higher performance reliability is required,  $L_{10}$  is often used. The  $L_{10}$  life means that of a given group of bearings, 90% are expected to survive. The relationship between  $L_{50}$  and  $L_{10}$  life is approximately 5 to 1. Therefore, if the  $L_{50}$  life is 10,000 cycles, the  $L_{10}$  life would be 2,000 cycles, at the rated dynamic load. The load/life relationship can be expressed:

$$L_{50} = \left( \frac{D.L.}{P_e} \right)^{3.67} \quad \text{for 10000 cycle life}$$

$$L_{10} = \left( \frac{D.L.}{P_e} \right)^{3.67} \quad \text{for 2000 cycle life}$$

where

D.L. = the dynamic load rating

$P_e$  = the dynamic operating load

The bearing life, based on race surface contact fatigue which is the assumed mode of failure, is a function of the number and magnitude of contact stresses at any given point on the race surface. Since the internal design of the bearing and the angle of oscillation determine the number of contact stresses, it becomes necessary to evaluate the effects of the degree of oscillatory motion upon the rated bearing life. Basically, the evaluation of the effect of the oscillation angle can be separated into two categories:

- a. Angle oscillation above  $25^\circ$  included angle. The failure mode is usually contact fatigue, in which case the life of the bearing is predictable. Generally speaking, the bearing life expectancy will increase as the angle of oscillation approaches  $25^\circ$ , from the rated oscillation of  $90^\circ$  included angle.
- b. Angles of oscillation below  $25^\circ$  included angle. Ordinarily the failure mode is fretting, in which event the bearing life is not predictable. At these lower angles of oscillation the adjacent roller paths do not overlap. Therefore, there is no opportunity for adequate redistribution of the grease and eventually the oil film will break down, resulting in metal-to-metal contact between the roller and the raceways.

It is advantageous to relubricate the bearing frequently to avoid possible fretting. Also, the circulation of grease in the bearing can be greatly assisted if the oscillation angles under  $25^\circ$  are interspersed with angles of motion above  $25^\circ$ . If the angle of oscillation is other than an included angle of  $90^\circ$ , the bearing life can be estimated by dividing the life at  $90^\circ$  by a factor from figure 201-12.

4.3.4.1.2.3 Equivalent and combined loads. Aerospace vehicle bearing applications rarely involve a constant, unidirectional load which is either purely radial or axial. If load magnitude is varying, an equivalent mean load can be computed to aid in bearing selection and sizing. Similarly, if both radial and axial components are present, they can be combined into radial load which has equal effect on the bearing life. The following procedure should be used in determining equivalent loads when applied loads are of varying magnitude and direction.

a. Symbols:

$P_c$  = equivalent radial dynamic load-lbs. (combining axial and radial dynamic loads)

$P$  = equivalent radial dynamic load at 90° osc. - lbs.

$P_1$  = individual equivalent radial dynamic load representing one condition in the spectrum-lbs.

$P_e$  = equivalent radial dynamic load representing the various loads in the spectrum-lbs.

$F_r$  = applied maximum radial dynamic load-lbs.

$F_a$  = applied maximum axial dynamic loads-lbs.

$f_1$  = number of cycles, at one condition, divided by the total spectrum cycles.

$K_e$  = oscillation factor-see figure 201-12

$C_y$  = total cycles required

$D.L._r$  = radial dynamic load rating-lbs

$L.L._a$  = axial limit load rating-lbs.

$L.L._r$  = radial limit load rating-lbs.

b. Procedure:

STEP 1. Determine the equivalent radial dynamic load.

$$P_c = F_r + 2.5 F_a$$

This equation combines the thrust and radial loads. The single row bearings carry momentary or intermittent thrust loads, but are, not for continuous thrust. Therefore, for single row bearings,  $P_e$  is equal to  $F_r$ . NOTE: If multiple operating conditions exist, they should be considered separately under steps (1) and (2), and then summarized in step (3).  $F_a$  must not exceed 30% of  $F_r$ .

STEP 2. Determine equivalent radial dynamic load at 90° oscillations.

$$P = K_o P_o$$

When oscillation is restricted to less than 25° included angle, lubrication may become a limiting factor, in which case, fretting damage terminates the useful bearing life. The  $K_o$  values, on the low oscillation range of figure 201-12 are, intended for initial selection. (Actual performance in this range of small motions may vary considerably with each application.)

STEP 3. Determine equivalent radial dynamic load representing spectrum loading (if applicable).

$$P_e = \left[ f_1(P_1)^{3.67} + f_2(P_2)^{3.67} + \dots + f_n(P_n)^{3.67} \right]^{.273}$$

This equation is used only when various load levels exist. If only one dynamic load level occurs, then P becomes  $P_e$  and step (4) can be completed.

STEP 4. Determine the required radial dynamic load rating.

$$D.L._r \geq \left[ P_e \frac{C_y}{10,000} \right]^{.273}$$

Average life ( $L_{50}$ ) is assumed in this equation. If a 90% ( $L_{10}$ ) survival is desired, then substitute 2,000 for 10,000 in the equation.

STEP 5. Select a bearing meeting the dynamic load rating requirement from requirement 302.

STEP 6. Check static load ratings or bearing selected.

The limit load rating on the selected bearing must be equal to or larger than the maximum applied static loads. Both radial and axial limit load ratings ( $L.L._r$  and  $L.L._a$ ) must be considered.

The ultimate load ratings is calculated as 1.5 times the limit load rating ( $L.L._r$  and  $L.L._a$ )

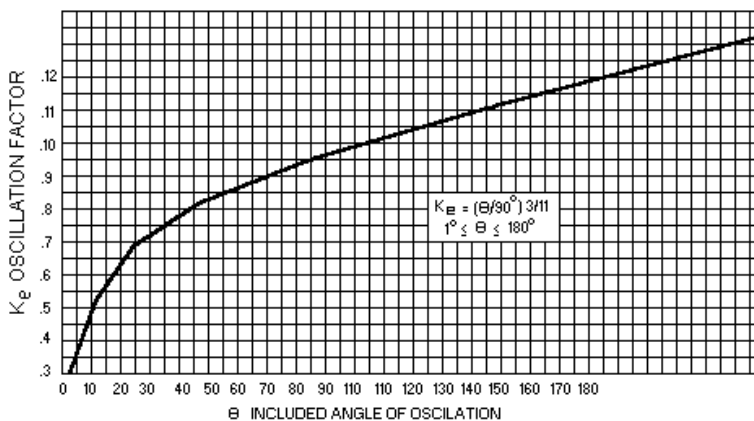


FIGURE 201-12. Oscillation angle factors for roller bearings.

4.3.4.1.3 Needle bearings.

4.3.4.1.3.1 Static capacity. The "limit load is the maximum static radial load which can be applied to a bearing without impairing its subsequent function in aerospace vehicle applications. The "ultimate load" or static fracture load is not less than 1.5 times the limit load rating. By definition the aircraft static capacity load rating is a load which does permanent damage to raceway and roller such that it should not be expected to perform in aerospace vehicle applications. In short, a load equal to the aircraft static capacity is a load that damages the bearing. Needle bearings can be separated into two general groups. The first group, which includes MS24461, MS24462, MS24463 and M324464, are designed to be installed in the users housing and would receive massive support from this housing. This differentiates this group from the second group (MS24465, MS24466 and MS21432) which are track rollers. This second group has heavy cross-sectioned outer rings and the bearings roll on these outer rings. The "limit load rating" for the first group with the exception of MS24462 series is equal to 2/3 of the aircraft static capacity and the "ultimate load rating" for the MS24462 series is equal to 1/2 the aircraft static capacity while the "ultimate load rating" is 3/4 ASC. The "limit load rating" for the MS24465 and MS24466 series of track rollers is 4/9 of ASC and the "ultimate load rating" is 2/3 of ASC. Extensive testing has shown that the "limit load rating" of the MS21432 is 2/3 of ASC and the "ultimate load rating" is equal to the ASC. To fully realize this rating, compensation must be provided for stud deflection to insure full track contact under load. Table 201-IXA, B and C list the limit load ratings and ultimate load ratings for the referenced MS series of needle bearings. The aircraft static capacity for needle bearings expressed in pounds with the exception of the MS24462 (drawn cup) series is based on the formula:

$$ASC = 12000 i (Z-3) \ell_{eff} D \quad \text{where}$$

$i$  = the number of rows of rollers

$Z$  = the number of rollers per row

$\ell_{eff}$  = the minimum roller contact length in inches

$D$  = the minimum roller diameter in inches

The ASC for the MS 24462 series is based on the formula:

$$ASC \text{ in pounds} = 15800 dm \ell_{eff} \quad \text{where}$$

$dm$  = pitch diameter of the roller complement in inches

$\ell_{eff}$  = minimum roller contact length in inches

MIL-HDBK-1599A

REQUIREMENT 201

TABLE 201-IXA. Capacity ratings of MS series needle bearings (housed typed).

	Limit loads (lbs)	Ultimate Loads (lbs)	Basic dynamic load Rating $C_r$ (lbs)
M324461- 3	1800	2700	805
- 4	2870	4300	1120
- 5	4070	6100	1430
- 6	6330	9500	1980
- 7	8000	12000	2310
- 8	11600	17400	3690
- 9	15000	22500	4450
-10	18900	28300	5220
-12	23900	35800	6060
-14	30500	45800	8540
-16	33900	50900	9030
-20	37900	56800	9420
-24	44200	66300	10200
-28	50500	75700	10900
-32	56800	85200	11600
-36	63100	94600	12400
-40	69400	104100	12900
-44	75800	113500	13500
-48	82000	123000	14100
-52	88300	132500	14600
-56	96700	145100	15300
-60	103000	154500	15800
-64	109000	169000	16300
-80	134000	201000	18100

MIL-HDBK-1599A

REQUIREMENT 201

TABLE 201-IXB. Capacity ratings of MS series needle bearings (housed type).

	Limit loads (lbs)	Ultimate load (lb.)	Basic dynamic load Rating $C_r$ (lb.)
MM4462 - 3	1150	1725	1280
- 4	1365	2050	1300
- 5	1535	2300	1400
- 6	2945	4420	2270
- 7	3235	4850	2900
- 8	3785	5680	3180
- 10	4350	6525	3460
- 12	7050	10600	4920
- 14	7900	11850	5250
- 16	8700	13050	5540
- 20	13100	19650	8980
MS24463 - 3	1800	2700	805
- 4	2870	4300	1120
- 5	4070	6100	1430
MS24464 - 6	4530	6800	1760
- 7	5870	8800	2110
- 8	8670	13000	3420
- 9	11800	17700	4300
- 10	15500	23200	5190
- 12	20000	30000	6160
- 14	25800	38700	8730
- 16	28700	43000	9230
- 20	31400	47100	9490
- 24	36600	54900	10200
- 32	47100	70600	11700
- 40	57500	86200	13000
- 48	67900	10190	14200
- 56	80100	12020	15300

MIL-HDBK-1599A

REQUIREMENT 201

TABLE 201-IXC. Capacity ratings for track roller bearings.

	Limit loads (lbs)	Ultimate loads (lbs)	Basic dynamic load Rating $C_r$ (lbs)
M524465 - 3	1150	1725	1280
- 4	1910	2860	1430
- 6	3600	5400	2700
- 8	5780	8600	4300
- 10	8530	12800	6400
- 12	14200	21406	10700
- 14	19300	28800	14400
- 20	25300	37800	18900
MS24466 - 6	7130	10740	5370
- 8	12500	18740	9370
- 10	19900	30000	15000
- 12	28500	42800	21400
- 14	38500	57800	28900
- 16	44900	67200	33600
- 20	59500	89200	44600
- 27	71300	107000	53600
- 28	92000	138000	69000
- 32	102000	153000	76600

4.3.4.1.3.2 Dynamic rating, housed needle bearings. When adequate lubrication for needle bearings exists, the mode of failure is considered to be surface fatigue. Basic dynamic rating,  $C_r$ , for a housed needled bearing (i.e., MS24461, MS24462, MS24463, and MS24464) is that calculated, constant, radial load which a group of apparently identical bearings with a stationary outer ring can theoretically endure for a rating life of one million revolutions rating of the inner ring. The basic dynamic load rating is a reference value only, the base value of one million revolutions rating life having been chosen for ease of calculation. Since applied loading as great as the basic dynamic load rating tends to cause local plastic deformation of the rolling surfaces, it is not anticipated that such heavy loading would normally be applied. Values for  $C_r$  can be found in tables 201-9A and 201-9B. The life of a housed needle bearing is expressed as the oscillations or cycles that a bearing will complete before failure. Life will vary from one bearing to another, but stabilizes into a predictable pattern when considering a large group of the same size and type of bearings. The "L-10" or "rating life" of a group of such bearings is defined as the number of revolutions (or hours at a given constant speed) that 90% of the tested bearings will complete or exceed before the first evidence of fatigue develops. Thus it can be predicted with 90% reliability that a bearing will meet or exceed the calculated "L-10" life providing normal fatigue is the failure mode. Some critical applications, however, require definition of life at reliability's greater than 90%. To determine bearing life with reliability's greater than 90%, the "L-10" life as calculated must be adjusted by a factor  $a_1$  so that  $L_1 = a_1 L_{10}$ . The life adjustment factors shown below are recommended.

MIL-HDBK-1599A

REQUIREMENT 201

Reliability %	$L_n$ rating life	$a_1$ life adjustment reliability factor
90	$L_{10}$	1
95	$L_5$	0.62
96	$L_4$	0.53
97	$L_3$	0.44
98	$L_2$	0.33
99	$L_1$	0.21

Empirical calculations and experimental data point to a predictable relationship between bearing load and life. This relationship may be expressed by a formula. In this empirical formula, the bearing life is found to vary Inversely as the applied load to an exponential power. The life of a housed bearing when failure is due to surface fatigue can be determined from the basic dynamic load rating and the equivalent load. This can be expressed by the relationship.

$$L_L = \frac{C_r}{P_e} \quad \text{where}$$

$C_r$  = basic dynamic load rating

$P_e$  = equivalent load

$L_L$  = life factor from figure 201-13

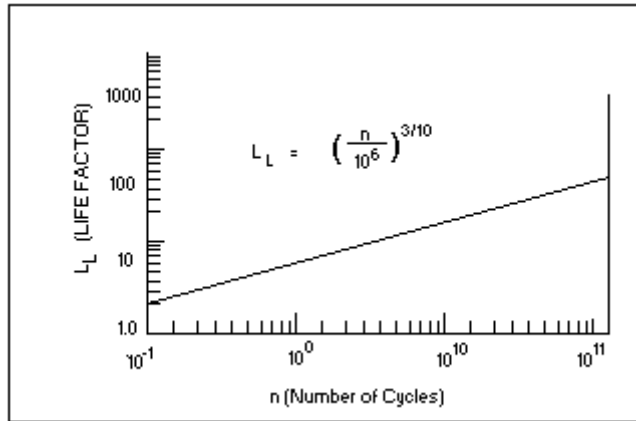


FIGURE 201-13. Life factors for housed needle bearings.

The above relationship holds for the usual aerospace vehicle application and the MS series of housed needle bearings. If the race hardness is less than Rc58 the above relationship must be modified to

$$L_L = \frac{C_r}{P_e \times H_F}$$

where  $H_F$  is a hardness factor taken from the following data:

MIL-HDBK-1599A

REQUIREMENT 201

raceway hardness (HRC)	hardness factor (HF)
58	1.00
57	1.02
56	1.04
55	1.07
54	1.12
53	1.19
52	1.28
51	1.41
50	1.59
49	1.78
48	2.00
47	2.24
46	2.50
45	2.76
44	3.06
43	3.39
42	3.77
41	4.16
40	4.55

For convenience basic load life curves for the MS series of housed needle bearings are shown in figures 201-30 through 201-33.

4.3.4.1.3.3 Equivalent loading, housed needle bearings. It is sometimes necessary to determine an equivalent load if the bearing is subject to various load levels during a duty cycle. This can be done by using the following relationship:

$$P_e = \left[ \sum f(F)^{10/3} \right]^{3/10} \text{ where}$$

$P_e$  = equivalent load, lb.

$f$  = proportion of total life at a particular load

$F$  = radial load level, lb.

The equivalent radial load should then be used in the load life calculations. In no case may the equivalent load exceed the indicated limit load for the bearing.

MIL-HDBK-1599A

REQUIREMENT 201

4.3.4.1.3.4 Dynamic rating, track rollers. The dynamic rating of the second group of needle bearings, the track rollers, is shown on figures 201-34, 201-35, and 201-36. Use the curves on these figures or charts to determine the load/life relationship. A limiting value is shown on the figures. Bearing "capacity as a track roller" data for these three series are shown on table 201-9C. This is defined as the load which will result in 20,000 revolutions L-10 of the track roller bearing. For loads less than the CTR, life is based upon a 10/3rds relationship. Thus:

$$L_L = \left( \frac{CTR}{P_e} \right)^{10/3} \times 20,000 \quad (CTR > P_e)$$

For loads in excess of the capacity of a track roller life values as a 6th power function. Thus:

$$L_L = \left( \frac{CTR}{P_e} \right)^6 \times 20,000 \quad (CTR < P_e)$$

Figures 201-14 thru -16 are a graphic representation of this data.

4.3.4.1.3.5 Equivalent loading, track rollers. To calculate the L-10 life in revolutions of a track roller bearing, use the information contained in paragraph 4.3.4.1.3.3 above. This formula is correct as long as the individual loads are less than the capacity as a track roller. If a significant portion of the bearing life occurs at loads in excess of the CTR, the following formula must be used:

$$L_L = \frac{20,000}{\sum Ti \left( \frac{Pe_a}{CTR} \right)^6 + \sum ti \left( \frac{Pe_b}{CTR} \right)^{10/3}}$$

where:

$L_L$  = life in revolutions L-10

$Pe_a$  = loads greater than CTR

$Pe_b$  = loads less than CTR

$Ti$  = fraction of the total revolutions at load  $Pe_a$

$ti$  = fraction of the total revolutions at load  $Pe_b$

CTR = bearing capacity as track roller

MIL-HDBK-1599A

REQUIREMENT 201

4.3.4.1.3.6 Track strength. Another factor in the use of track rollers is the strength of the supporting track to resist permanent deformation by the track roller bearing. The strength of the track is often considerably less than the load that the bearing can support. When using a 180,000 psi or lower strength track, the strength of the track is the determining factor rather than any characteristic of the bearing. The strength of the track can be increased by selecting a track material which can be hardened to higher strength levels. The relationship between track hardness and track strength is shown in figure 201-14. Note that this relationship applies to steel tracks only and does not apply to track surfaces of other materials, such as titanium.

4.3.4.2 Plain bearings.

4.3.4.2.1 Spherical, TFE lined. Radial and axial static limit loads are tabulated on the military standards for bearings approved in requirement 307. The loads defined in MIL-B-81820 are as follows:

- a. The radial static limit load is that load (when applied for two minutes to the bearing) which will not cause a permanent set of more than 0.003 in.
- b. The axial static limit load is that load (when applied for two minutes to the bearing) which will not cause a permanent set of more than 0.005 in.
- c. The ultimate load is 1.5 times the radial or axial limit load. When this load is applied to the bearing, ball or race fracture or ball push-out will not occur.

4.3.4.2.1.2 Dynamic capacity. The military standards list a qualification dynamic load rating for these bearings. The qualification test per MIL-B-81820 is conducted under various sets of stated conditions which fall within the range of aerospace vehicle applications. For example, under loading at the dynamic load rating,  $\pm 25^\circ$  oscillation, a testing rate of 10 CPM, and room temperature, the bearing must perform for 25000 cycles with no more than 0.0045 inch wear. A number of other factors, when combined with those stated above, affect the wear rate of the bearing. These include: (1) type of loading (unidirectional or reversing), (2) angle of oscillation, (3) oscillation rate, (4) temperature, and (5) contamination. Bearing manufacturers, as well as aerospace vehicle designers, have produced considerable test data resulting in modifying factors or curves which may be used to aid in bearing selection. It should also be noted that the controlling MIL-B-81820 for these bearings permits adjustments downward in load and upward in allowable wear for certain conditions of temperature and contamination. Since the effects of the variables on the life of a TFE-lined bearing are relatively intangible, both previous experience and performance demonstrating functional testing play an important part in the selection process. An example of a method for TFE-lined bearing selection for an application follows.

Procedure to select a bearing for  $L_N$  Cycles of Oscillatory life at an oscillation angle,  $\theta$ , and load, P:

- (1) Determine an equivalent life,  $L_E$ , from the expression,

$$L_E = \frac{L_N F_A F_C}{K_q} \quad \text{where}$$

$F_A$  = application factor (factors additive, if more than one condition applies)

$F_C$  = contamination factor

$K_\theta$  = angle factor from figure 201-15

(2) Using  $L_E$ , from figure 201-16

(3) The required rated dynamic capacity,  $P_R$ , of the bearing is determined from the relationship,

$$P_R = \frac{P}{F_L}$$

(4) Select a bearing with a dynamic load rating equal to or greater than  $P_R$

(5) Check bearing static rating against the design static loads.

<u>Condition</u> .....	$F_A$
Steady load	1
Reversing load	2
Vibration	3
Impact load	4
-65°F to 0 and 175°F to 350°F	2
Continuous misalignment	2
<u>Degree of contamination</u> .....	$F_C$
none	1
occasional	2
continuous	6

NOTE: A bearing size factor is included in the MS ratings. Oscillation rate factors are not significant in aerospace vehicle applications where the rate is low and intermittent.

4.3.4.2.1.3 Equivalent load. Where the design loading varies during the bearing duty cycle, compute an equivalent load,  $P_E$ , from the following relationship and use it in the life calculations.

$$P_E = \left[ \sum K(P)^{3.6} \right]^{\frac{1}{3.6}} \quad \text{where}$$

$P$  = applied load levels;  $P_1, P_2, P_3, \dots, P_N$ .

$K$  = proportion of the duty cycle at which the various load levels are applied.

MIL-HDBK-1599A

REQUIREMENT 201

$$T = T_{40} \times F_T$$

where

T = Track capacity for a specific bearing, lb  
 T<sub>40</sub> = Capacity of R<sub>c</sub> = 40 track (standard MS sheets), lb  
 F<sub>T</sub> = Track strength factor from graph

If T<sub>40</sub> is not known  
 where

T = Track capacity for specific bearing, lb  
 D = OD of track roller, in.  
 L = Contact length of track roller, in.  
 K = Constant, psi, from graph

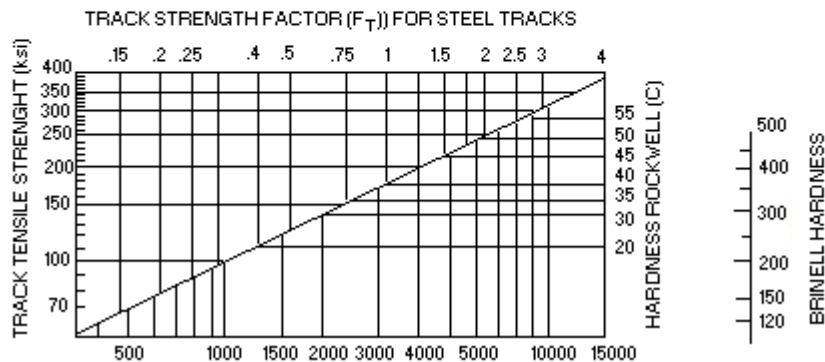


FIGURE 201-14. Strength factors for tracks of different hardness.

4.3.4.2.2 Spherical bearings, grease or dry film lubricated

4.3.4.2.2.1 Static capacity. The controlling specifications define the static limit load capacity as a load at which a specified amount of permanent set is not exceeded. The values selected are such that subsequent operation of the bearing is not adversely affected. Ultimate load capacity is not less than 1 1/2 times the limit load capacity. At ultimate capacity no fracture of the ball or race or ball pushout will occur.

4.3.4.2.2.2 Dynamic capacity. Dry film lubricated bearings have high dynamic capacity up to 50,000 psi unit loading, but life is difficult to predict due to wear through the thin coating. Accordingly, they are best used in joints which are relatively static under load with only incidental rotation or misalignment motion. Bronze race bearings will provide essentially unlimited service life when loaded up to 13000 Psi, properly lubricated and operated at 10 CPM maximum. For shorter, finite life at higher loads, stress values from figure 201-14 can be used with the bearing race projected area. Bearings using beryllium copper balls are rated at 30,000 psi to 40,000 psi, depending on whether rotation is at the spherical surface or In the bore, and whether ball is clamped or free to rotate on the pin.

4.3.4.2.3 TFE-lined Journal bearings

4.3.4.2.3.1 Static capacity. The static limit load capacity of these bearings is defined by MIL-B-81934 as

SL = 50,000 B (L-.1) for aluminum bearings, and  
 SL = 78,500 B (L-.1) for CRES bearings,

MIL-HDBK-1599A

REQUIREMENT 201

where

SL = static limit load capacity, lbs.

B = bearing bore, in.

L = bearing length, in.

Due to pin bending and edge loading, static capacity is not significantly improved by increasing bearing length beyond a dimension equal to the bore diameter.

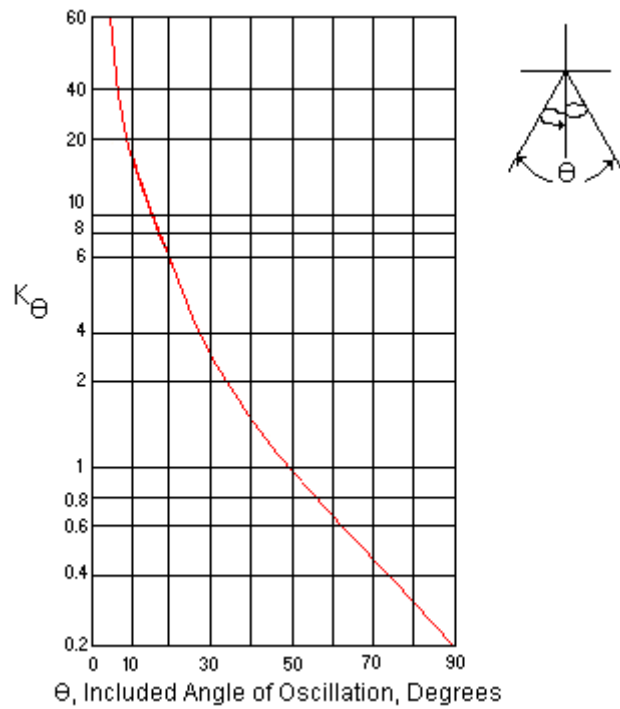


FIGURE 201-15. Oscillation angle factor  $K_\theta$  for TFE-lined plain spherical bearings

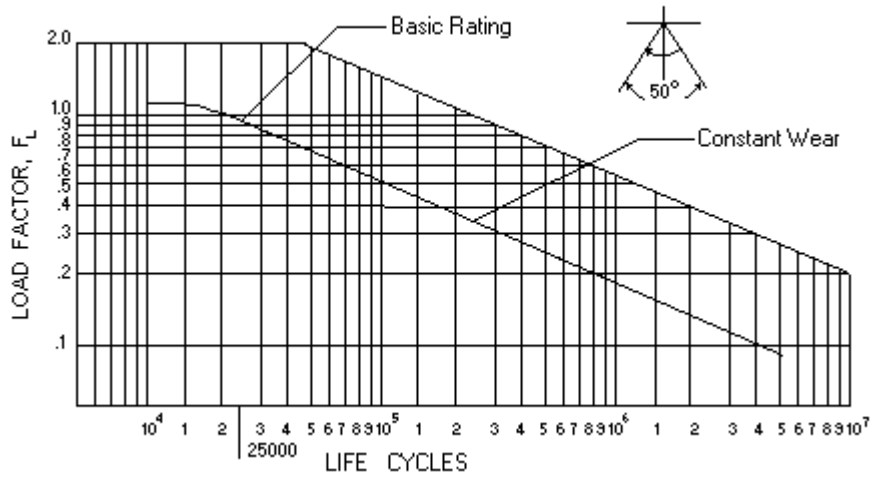


FIGURE 201-16. Load/life characteristics of TFE-lined plain spherical bearings.

4.3.4.2.3.2 Dynamic capacity. The dynamic load capacity, under the specification qualification conditions, is defined as

$$DL = 37,500 B (L-.1), \text{ where}$$

DL = dynamic load capacity, lb.

B = bearing bore, in.

L = bearing length, in.

Figure 201-17 is a nomograph which relates bearing life, applied load, angle of oscillation, and the projected area of the bushing. It is intended as an aid in sizing a bearing for a specific application. In addition, the procedures outlined for considering variables in selecting a TFE-lined spherical apply to journal bearings. The performance indicated in figure 201-17 will be obtained only with a properly designed pin, shaft, or bolt as a mating member. Such a design includes a blended lead-in to avoid installation damage, a minimum hardness of RC 40, and a surface finish of at least RHR 8. This finish should be obtained by a final operation other than grinding, such as honing, polishing, or lapping.

4.3.4.2.4 Metallic Journal bearings.

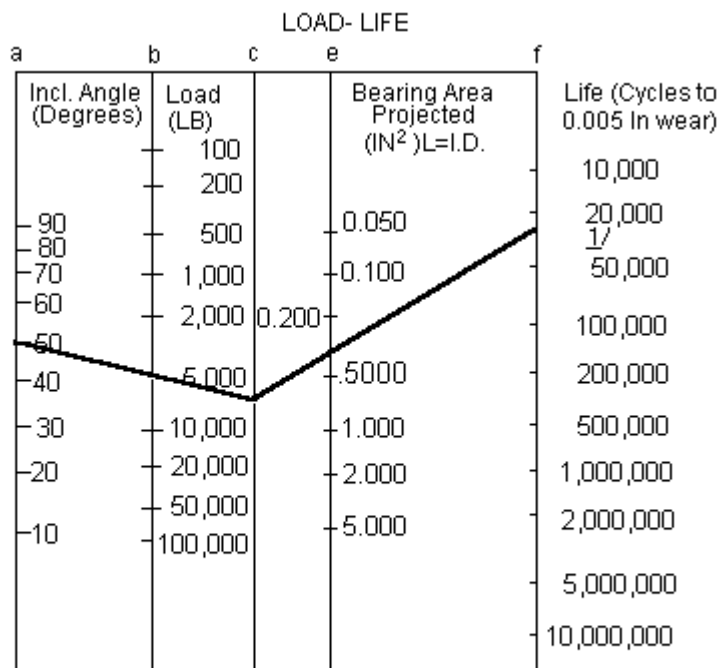
4.3.4.2.4.1.1 Static capacity. Metal journal bearings are used primarily to handle static loads and can be loaded to values that are approximately one-half of the compressive yield strength of the material. Using the projected area of the bearing (length x diameter) with the stress values in figure 201-18, the load capacity can be determined.

MIL-HDBK-1599A

REQUIREMENT 201

4.3.4.2.4.2 Dynamic capacity. Although steel bushings (if lubricated) can be used for a few cycles of low speed oscillation without galling or excessive wear taking place, bronze bushings should be employed if an appreciable amount of motion is expected between the shaft and the bushing. Under dynamic conditions, excessive wear of the bronze bushing is the mode of failure. Figure 201-19 is a plot of life versus unit load under well-lubricated (MIL-G-81322 grease) conditions.

5. Installation and retention. Design requirements and recommendations for bearing installation and retention are covered in requirement 202. Satisfactory bearing performance is obtained by proper installation practice and appropriate retention techniques as much as by optimum bearing selection.



1/ EXAMPLE: A plain bearing with 0.3 IN<sup>2</sup> projected area, operating at ±25° oscillation and 5,000 lbs load will give 26,000 cycles of life before 0.005 IN. wear occurs.

1/ EXAMPLE: A PLAIN BEARING WITH 0.3 IN<sup>2</sup> PROJECTED AREA, OPERATING AT ±25° OSCILLATION AND 5,000 LBS LOAD WILL GIVE 26,000 CYCLES OF LIFE BEFORE 0.005 IN. WEAR OCCURS.

FIGURE 201-17. Load/life characteristics for TFE-lined Journal bearings

MIL-HDBK-1599A

REQUIREMENT 201

6. Miscellaneous design considerations.

6.1 Lubrication provisions. Requirement 203 specifies methods required for provision of lubrication facilities where applicable including location of fittings relative to access for relubrication.

6.2 Bearing safetying. Requirement 204 specifies requirements for and methods of safetying bearings.

MATERIAL	YIELD STRESS, KSI	MAXIMUM TEMPERATURE* (°F)
4130 Steel (180 KSI UTS)	115	350
17-4 Steel (AMS 5643)	90	500
Beryllium Copper (Fed Spec QQ-C-530)	90	350
Al-Ni-Bronze (AMS 4640 and 488)	60	350
Al-Bronze (Fed Spec QQ-C-465)	40	350

Maximum temperature at which bushing can be used without loss of static capacity.

FIGURE 201-18. Stress capability of metal Journal bearings.

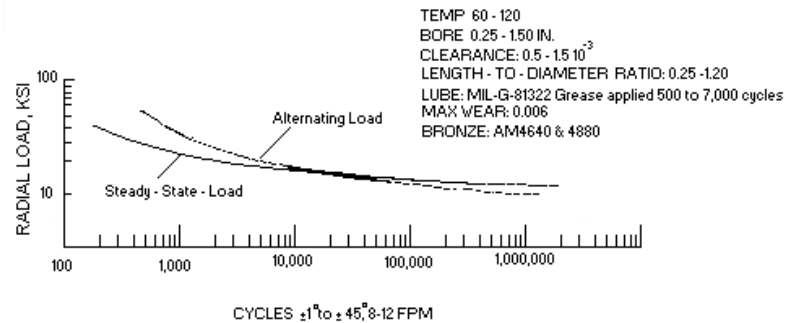


FIGURE 201-19. Load/life-characteristics for grease lubricated journal bearings.

MIL-HDBK-1599A

REQUIREMENT 201

7. Quality assurance provisions in design.

7.1 Proof loading for retention. Where retention methods are used which require proof loading, engineering drawings specifying the bearings shall also specify the requirement for proofloads and proof load value and direction.

7.2 Safetying. Where safetying is required, the engineering drawing specifying the bearing shall also specify the requirement for and method of safetying. The engineering drawing may reference a DOD or contractor document which delineates safetying of methods and procedures.

7.3 Starting torque. Where starting torque is critical to functioning of an assembly, the installation drawing specifying the bearing shall include a notation that starting torque shall be within a specified range or a maximum range after bearing is installed.

MIL-HDBK-1599A

REQUIREMENT 202

BEARING RETENTION

1. Scope. This requirement establishes engineering criteria and design information relative to the installation and retention of bearings to facilitate their proper airframe usage (see requirement 201). Included in the text will be information concerning the various techniques for-installing each class of airframe bearings in the various housing materials which may be encountered in an airframe. Where applicable, this requirement will also present engineering criteria and design information relative to the removal and replacement of airframe control bearings.

2. Applicable Documents.

QQ-P-416	Plating, Cadmium (Electrodeposited)
MIL-A-8625	Anodic Coatings, for Aluminum and Aluminum Alloys
MIL-STD-889	Dissimilar Metals
MS14101	Bearing, Plain, Self-Lubricating, Self-Aligning, LowSpeed, Narrow, Grooved Outer Ring, -65°F to 350°F
MS14102	Bearing, Plain, Self-Lubricating, Self-Aligning, Low-Speed, Wide, Grooved Outer Ring, -67°F to 325°F
MS14103	Bearing, Plain, Self-Lubricating, Self-Aligning, Low-Speed, Wide, Grooved Outer Ring, -65°F to 325°F
MS14104	Bearing, Roller, Rod End, Internal Thread, Self-Aligning, Low-Speed, Narrow, Chamfered Outer Ring, -65°F to 325°F
MS21220	Bearing, Roller, Rod End, Internal Thread, Self-Aligning, Anti-Friction, Airframe, Heavy Duty, Type II, -67°F to 250°F, Sealed
MS21221	Bearing, Roller, Rod End, External Thread, Self-All-Aligning, Anti-Friction, Airframe, Heavy Duty, Type I, -67°F to 250°F
MS21429	Bearing, Roller, Anti-Friction, Rod End, External Thread, Self-Aligning, Airframe, -67°F to 350°F, Type I, Heavy Duty, Sealed
MS21431	Bearing, Roller, Self-Aligning, Single Row Anti-Friction, Sealed, -65°F to 350°F, Type I
MS21432	Bearing, Roller, Needle, Track Roller, Integral Stud, Type VII, Anti-Friction, Inch
MS21438	Bearing, Roller, Needle, Single Row, Heavy Duty, Self-Aligning, Type III, Anti-Friction, Inch Sealed
MS21439	Bearing, Roller, Needle, Double Row, Heavy Duty, Track Roller, Type VI, AntFriction, Inch, Sealed
MS34461	Bearing, Roller, Needle, Single Row, Heavy Duty, Type 1, Anti-Friction, Inch
MS24463	Bearing, Roller, Needle, Single Row, Heavy Duty, Self-Aligning, Type III, Anti-Friction, Inch
MS24464	Bearing, Roller, Needle, Double Row, Heavy Duty, Self-Aligning, Type IV, Anti - Friction, Inch
MS27640	Bearing, Ball, Airframe, Anti-Friction, Heavy Duty,
MS27641	Bearing, Ball, Airframe, Anti-Friction, Intermediate Duty
MS27642	Bearing, Ball, Airframe, Extra Light Duty
MS27643	Bearing, Ball, Airframe, Anti-Friction, Self-Aligning, Double Row, Heavy Duty,

MIL-HDBK-1599A

REQUIREMENT 202

MS27644	Bearing, Ball, Airframe, Anti-Friction, Double Row, Heavy Duty,
MS27645	Bearing, Ball, Airframe, Anti-Friction, Self-Aligning, Light and Heavy Duty,
MS27646	Bearing, Ball, Airframe, Anti-Friction, Extra Light Duty,
MS 27647	Bearing, Ball, Airframe, Anti-Friction, Extra Wide, Double Row, Intermediate Duty,
MS27648.	Bearing, Ball, Airframe, Anti-Friction, Externally SelfAligning, Extra Light Duty,
MS27649	Bearing, Ball, Airframe, Anti-Friction, Intermediate Duty,
MS28912	Bearing, Roller, Self-Aligning, Single Row, Airframe, Anti-Friction, Sealed, Type I
MS28913	Bearing, Roller, Self-Aligning, Double Row, Airframe, Anti-Friction, Se Sealed, Type II
M328914	Bearing, Roller, Self-Aligning, Double Row, Wide Inner Ring, Airframe, Anti-Friction, Sealed, Type III
M328915	Bearing, Roller, Self-Aligning, Double Row, Torque Tube, Airframe, Anti-Friction, Sealed, Type IV

3. General. A bearing is a machine element intended to permit a load to be transmitted from one structural member to another, while at the same time permitting relative movement between the two structural members. Incorrect bearing installation and retention can result in a reduction in bearing useful life, an increase in bearing operating torque, or irreparable damage to the housing or bearing components. Proper installation and retention techniques and processes shall be used to assure proper bearing performance. Regardless of the type of bearing being installed, preinstallation precautions shall be taken as follows:

- a. The installation area shall be clean so that contaminants do not come into contact with the bearing.
- b. Assembly tools and fixtures shall be maintained in good working condition.
- c. Bearing shall be kept in their protective packaging until time of installation.
- d. The housing bore shall be free from all metal chips, filings, and other foreign material.

3.1 Corrosion considerations. Galvanic corrosion occurs when two dissimilar materials are in contact in a medium capable of carrying electrical current. Requirement 105 of this document describes the procedures for preventing galvanic corrosion. In addition, table 202-I of this requirement outlines some recommended treatments.

3.2 High temperature considerations differences in expansion coefficients. Expansion coefficients of bearings, shafts, and housing materials are, in many cases, radically different and must be carefully considered when mounting bearings. Some typical ranges for expansion coefficients are shown in table 202-II. Figure 202-1 demonstrates the expansion differences that occur when bearings, housings, and shafts of different expansion characteristics are used at elevated or cryogenic temperatures. In many cases, the expansion coefficient match determine the bearing material selection. The selection of materials of similar expansion characteristics of bearings, housings, and shafts is preferable to using complicated mechanical retention methods. Bearing, shaft, and housing materials can be divided into two classes according to their expansion characteristics.

MIL-HDBK-1599A

REQUIREMENT 202

In general, materials in the same class can be used together with out ' expansion mismatch problems if bearing diameters are small, if operating temperatures are not extreme, or if radial play requirements are not critical. Care must also be used in selecting rolling element materials which vary in expansion coefficient from the race materials. A change in bearing radial play will be evident as the temperature is raised or lowered. Spherical bearings constructed of different ball and outer race materials must also be provided with the proper radial play to compensate for expansion differences. The usefulness of the interference fit method of mounting for high temperature bearings depends on the difference between the expansion coefficients of the bearing and the shaft or housing. The practical maximum that can be tolerated is a difference in expansion coefficient of approximately  $1.0 \times 10^{-6}$  in/in/°F. This expansion difference could give a relief of 0.0005/in of diameter to a press fit at an operating temperature of 600°F and 0.0018 at an operating temperature of 1900°F.

4. Installation.

4.1 Method of installation. Use the proper tools and procedures to install bearings. Apply pressure only on the race of a bearing in contact with the housing or shaft. Figure 202-2 shows proper methods of installing bearings.

4.2 Shaft and housing-fits rolling element bearings.

4.2.1 Proper fit of a rolling element (anti-friction) bearing is a critical factor in bearing life. Most bearings have sufficient internal clearance to permit an interference on either shaft or housing. An interference fit in both places may preload the bearing. A slight preload can improve bearing performance as it improves the load distribution within the bearing while a large preload could reduce bearing life.

4.2.2 Airframe ball and roller bearings (see requirements 301 and 302) are customarily mounted with a clearance fit between the shaft or pin and the bore of the inner ring. With the exception of torque tube bearings (see requirement 201, Bearing Usage), the outer ring is press fit into the housing and retained in the axial direction by staking or other mechanical means. When light alloy housings are used, the axial restraint mechanism used becomes extremely significant due to the difference in thermal properties between the bearing and housing materials.

4.2.3 Press fit installation should be avoided when mounting either the inner or outer rings of a torque tube bearing (see requirement 201, Bearing Usage) in order to prevent an excessive bearing preload. A line-to-line or clearance fit should be used between the housing bore and bearing outer ring with suitable axial restraint by staking or other mechanical means.

4.2.4 In many airframe bearing applications, the shaft revolves (or oscillates) and the housing remains stationary in relation to the direction of the radial load. Recommended shaft and housing fits for this type of application, for average operating conditions are shown in tables 202-III through 202-IX.

4.2.5 The required fit of the inner ring on the shaft will vary with the application and the service. In some series only housing fits are shown, as the bearings listed do not require a precise fitting on the shaft.

4.2.6 Recommended housing fit varies with bearing series, and varies with housing material within any series. Also both shaft and housing fits are recommended for some series since these bearings have a wider range of application than most airframe bearings.

MIL-HDBK-1599A

REQUIREMENT 202

4.2.7 Recommended housing bore tolerances shown in tables 202-III and 202-VI through 202-IX will usually result in satisfactory installation when used in conjunction with the internal clearances shown in the bearing listings of the military standards shown in the requirement 302 for this type of bearing. The final running fit, within a bearing of this nature, is dependent on many factors', such as: the individual housing design, bearing internal clearance, housing material, operating temperature and the amount of interference between the bearing and the housing.

4.2.8 The outer ring sections of many annular bearings are thin enough to be easily distorted during installation. The final shape of the bearings depends largely on the roundness of the housing bores (see table 202-VI and 202-IX for the recommended roundness of housing bores).

4.2.9 The normal fit-up practice for non-press or loose fits, between an anti-friction roller bearing and housing requires that the tolerance range for the bearing O.D. be on the minus side of the nominal diameter and that the tolerance range for the bearing O.D. be on the minus side of the nominal diameter and that the tolerance range for the housing bore be on the plus side of the nominal diameter. Thus, the resulting fit-up range is line-to-line to slightly loose.

4.3 Shrink fits (anti-friction bearings).

4.3.1 A bearing may be installed by cooling or heating so that the thermal contraction or expansion permits assembly without metal-to-metal interference. When the assembly returns to room temperature, the desired interference is obtained. In general, airframe bearings can be heated to +250°F safely and in many cases to +350°F.

4.3.2 High temperature bearings can usually be heated to at least 600°F without damage if no lubricants are present. A dry ice and methanol bath is capable of chilling parts to -120°F, but suitable ventilation must be used. Liquid nitrogen is the preferred coolant when available and is capable of providing temperatures to -320°F. Deep freezing may be prohibited by some manufacturers as it can affect the crystalline structure of some steels.

4.3.3 When using high temperatures to cause thermal expansion to permit bearing installation, it must be remembered that the temperatures may effect the heat treat condition of the bearing shaft or housing.

CAUTION

- A. Do not use force or impact to complete or correct an improper installation after the bushing or bearing has warmed sufficiently to create an appreciable interference.
- B. Do not reuse a bearing or bushing which has been installed with a shrink fit and then has been forcibly removed.

MIL-HDBK-1599A

REQUIREMENT 202

4.3.4 Many of the materials used for high temperature bearings, shafts, and housings are nickel-based alloys which tend to gall readily either in making a press fit or in removal of the bearing. When press-fits are made, the fact that M032 oxidizes to M003 when exposed to temperatures over 7500 should be remembered. This oxide occupies a larger volume than the original MOS2 and may tend to jam the mating parts. Graphite is the preferable lubricant when operating temperatures are over 7500. In designing shrink fits for high temperature bearings, there is a tendency to specify very tight fits at room temperature in order to overcome the effects of varied expansion coefficients and high operating temperature. This may stress the housing past its elastic limit or bind the bearing so that it will not turn freely at room temperature. Housing fits suitable for steel housings and shafts at normal temperatures can be used as a basis for computing dimensions necessary, at installation temperatures, to obtain correct fits at elevated or low temperatures.

4.4 Shaft and housing fits (plain bearings). The housing bore fit should be from line-to-line to .001 inch loose to prevent lock-up or bind. In order to obtain this fit, the housing bore shall be equal to the bearing outside diameter plus .0005 inch. Plated or anodized housings may require secondary machining. The pin fit should be from line-to-line to .0030 inch loose.

5. Bearing retention.

Methods. Examples of axial retention methods for bearings on the shaft are shaft shoulders, interference fits, and nut nuts holding the bearing against a shaft shoulder. This last method is not advised in heavily loaded airframe bearing applications due to weakening of the shaft by the threads. Shaft shoulders should be provided with a fillet (generally undercut) at their base, compatible with the chamfer or radius on the bearing bore. Axial retention of the bearing in the housing can be accomplished by one of the methods listed in table 202-X, which shows the advantages of each method.

Table 202-I. Treatment to prevent galvanic corrosion. (see requirement 105)

BEARING MATERIAL	HOUSING OR SHAFT MATERIAL					
(BORE & OD SURFACE)	ALUMINUM ALLOYS A	LOW ALLOY STEELS A,C	TITANIUM A	CORROSION RESISTANT STEELS A	SUPER ALLOYS I	REFRACTORY METALS I
Aluminum alloys	A	A,C	A	A	I	I
Bronze & brass	I	I	G	S	S	I
Bronze & brass Cadmium plated	A	C	I	I	I	I
52100 and low alloy steels	A,C	C	N	I	I	I
440C Stainless steel	A	I	G	S	S	I
440C with wet primer	A	C	G	S	I	I
Corrosion-resistant steels	A	I	G	S	S	I
300 series steels (17-4, etc)	A	C	G	S	I	I
Superalloys-Rene (41,etc)	I	I	G	S	S	O
Cermets (LT-2, TiC, etc.	I	I	G	S	S	O
Ceramics Al <sub>2</sub> O <sub>3</sub> , ZrO <sub>2</sub>	I	I	G	S	S	O

- I - Incompatible
- A - Anodize aluminum per MIL-A-8625, type I or type II
- C - Cadmium plate low alloy steels per Fed-Spec QQ-P-416, type II, class 2
- G - Use dry film on bearing OD and in titanium bore
- N - Nickel plate per MIL-C-26074, grade C, class I or equivalent.
- O - Oxidation-resistant coating normally used will provide galvanic protection
- S - Satisfactory for use with no surface treatment.

Note: If plating or anodizing are required it will be necessary to re-establish the housing tolerance  
 \*See MIL-STD-889 for other combinations

MIL-HDBK-1599A

REQUIREMENT 202

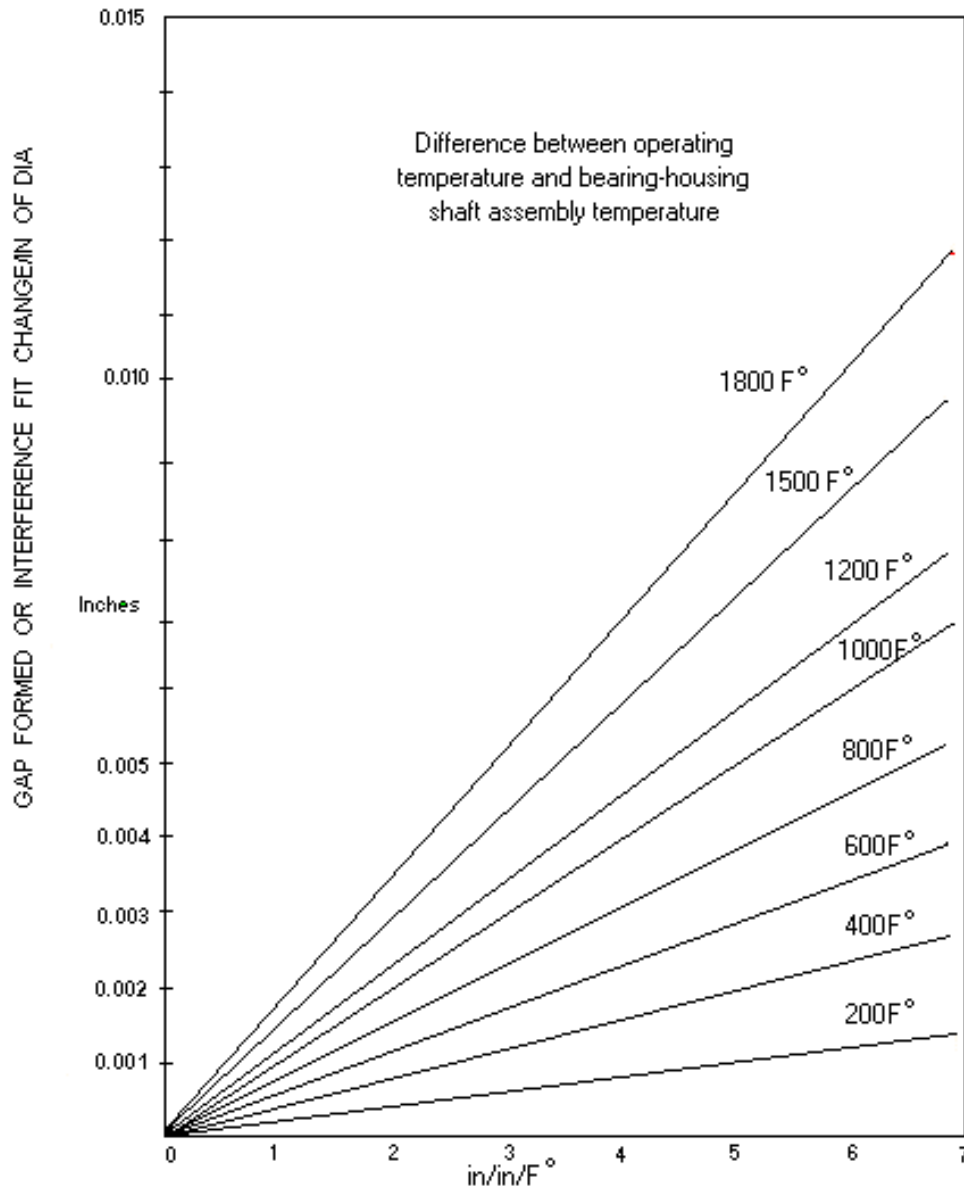
Table 202-II. Expansion classes of materials.

BEARING MATERIALS	SHAFT MATERIALS	HOUSING MATERIALS
Low Expansion Class ( $4.5 \times 10^{-6}$ to $6.2 \times 10^{-6}$ in/in/°F)		
Stainless steels Tool steels 400 Series SS Los alloy steels  MoS 2-metal compacts Titanium alloys	Stainless steels Tool steels 400 Series SS  Titanium alloys	Stainless steels  400 Series SS  Titanium alloys
High Expansion Class. ( $6.2 \times 10^{-6}$ to $15 \times 10^{-6}$ in/in/°F)		
A-286 Rene 41 Stellites, 3,19 & 25 M-252 Waspaloy Inconels other super-alloys Aluminum Magnesium	A-286 Rene 41 Other super-alloys  Inconels	A-286 Rene 41   Inconels  Aluminum Magnesium
Copper Based Alloys (Bearing Material only)		
Beryllium copper	$9.5 \times 10^{-6}$ in/in/°F	
Aluminum bronze	$9.5 \times 10^{-6}$ in/in/°F	
Aluminum nickel bronze	$9.0 \times 10^{-6}$ in/in/°F	
Aluminum silicon bronze	$10.0 \times 10^{-6}$ in/in/°F	

NOTE: See MIL-HDBK-5 for actual coefficients if necessary.

MIL-HDBK-1599A

REQUIREMENT 202



DIFFERENCE IN EXPANSION COEFFICIENT BETWEEN SHAFT OR HOUSING AND BEARING ( $\times 10^{-6}$ )

Figure 202-1. Expansion difference between bearings, shafts, and housings.

MIL-HDBK-1599A

REQUIREMENT 202

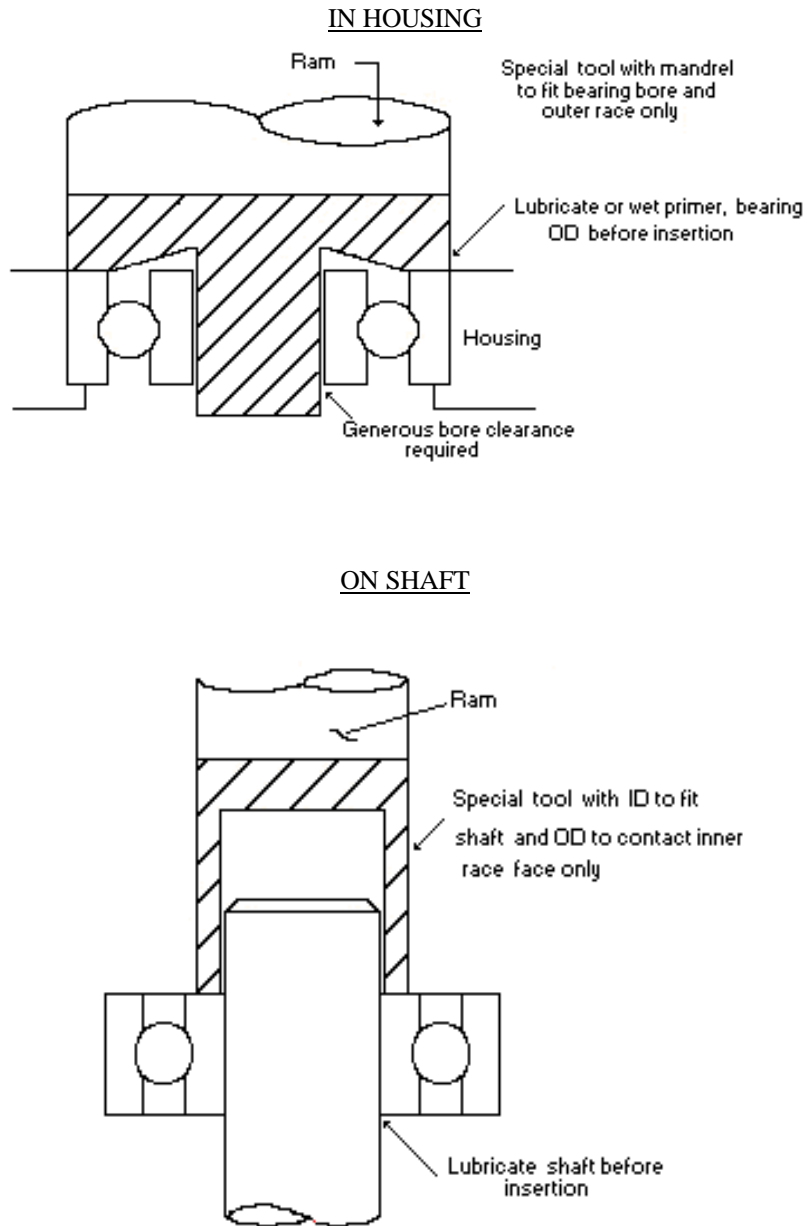


Figure 202-2. Method of installation-

MIL-HDBK-1599A

REQUIREMENT 202

Table 202-III. Recommend shaft and housing bore tolerance limits  
 airframe needle roller bearings M324461 (NBC);  
 MS24463 (NBE); MS24464 (NBK)

Deviations in 0.0001 Inch

Outside Diameter		Housing Bore Deviation from D			
D (Inches)		Transition Fit (Loose Range)		Transition Fit (Tight Range)	
Over	Incl	Low	High	Low	High
0.6250	1.2500	-8	-3	-1	4
1.2500	2.0000	-9	-3	-1	5
2.0000	3.0000	-12	-4	-1	7
3.0000	6.0000	-15	-5	2	8

Bore		Housing Bore Deviation from d			
d (Inches)		Transition Fit (Loose Range)		Transition Fit (Tight Range)	
Over	Incl	High	Low	High	Low
0.1250	1.0000	-6	-11	2	-3
1.0000	1.7500	-6	-12	3	-3
1.7500	3.0000	-6	-13	3	-4
3.0000	4.0000	-6	-14	4	-4
4.0000	5.0000	-6	-15	4	-5

The tight range shaft diameters and the tight range housing bore should not be used in conjunction as all radial clearance in the bearing may be removed.

For clamping surface diameters see applicable MS.

MIL-HDBK-1599A

REQUIREMENT 202

Table 202-IV. Recommended shaft diameter tolerance limits, airframe  
 needle roller bearings, track roller, yoke type  
 (MS21438 and MS21439).

Deviations in 0.0001 inch

Bore		Shaft Diameter Deviation From d			
d(Inches)		Transition Fit (Loose Range)		Transition Fit (Tight Range)	
Over	Include	High	Low	High	Low
0.1250	1.0000	-6	-11	2	-3
1.0000	1.7500	-6	-12	3	-3
1.7500	3.0000	-6	-13	3	-4

For clamping surface diameters see applicable MS.

Table 202-V. Recommended mounting dimensions, airframe  
 needle roller bearings, track roller, stud type  
 (MS21432 (HRS)).

Dimensions in inches

Bearing Number	Housing	Bore	Clamping Torque 1/ Inch Pounds Max	Bracket Shoulder Diameter Min.	Mounting Overhang Space 2/ Min	Fillet Radius Max
	Low	High				
HRS1C	0.1900	0.1905	8	0.2970	0.313	0.010
HRS2C	0.2500	0.2505	20	0.3590	0.313	0.010
HRS3C	0.3120	0.3125	43	0.4220	0.376	0.010
HRS4C	0.3750	0.3755	55	0.5000	0.501	0.025
HRS5C	0.4370	0.4375	150	0.5620	0.563	0.025
HRS6C	0.5000	0.5005	205	0.6250	0.688	0.400

1/ Add 0.050 inch when the HRSLCF or the HRS2CF versions are-used.

2/ Clamping torque based on lubricated threads.

MIL-HDBK-1599A

REQUIREMENT 202

Table 202-VI. recommended shaft and housing tolerance, airframe roller bearings, other than torque tube type MS28914. MS28913 (DAS); MS21431 (Sk); M321220\*(SF); MS21221\*(SM); MS21429\*(DM).

**RECOMMENDED HOUSING BORE TOLERANCE**

Limits in 0.0001 inch

Outside Diameter D (Inches)		Deviation From D				
		Steel		Light Alloy		Roundness (TIR)
Over	Include	Low	High	Low	High	
--	2	-5	-10	-9	-14	4
2	4	-7	-14	-11	-18	5
4	7	-10	-20	-14	-24	6

**RECOMMENDED SHAFT TOLERANCE**

Bore d (Inches)	Shaft Diameter Deviation From d		
	Include	Low	High
--	2	-10	-5

\*Shaft fit only

**HOUSING BORE TOLERANCE AND ROUNDNESS (IN INCHES)  
FOR ANNULAR OUTER RING ROLLER BEARINGS**

BEARING		
Style	Outside Diameter	
	Over	Include.
Other Than	--	2.0000
Torque Tube Type	2.0000	4.0000
	4.0000	7.0000
Torque Tube Type (DAT Series)	--	2.0000
	2.0000	4.0000
	4.0000	7.0000
	7.0000	10.0000

HOUSING BORE		
Tolerances*		Roundness (T.I.R.)
Steel	Light Alloy	
-0.0005/-0.001	-0.0009/-0.0014	0.0004
-0.0007/-0.0014	-0.0011/-0.0018	0.0005
-0.001/-0.002	-0.0014/-0.0024	0.0006
0.0008/-0.0000	+0.0006/-0.0000	0.0004
0.0009/-0.0000	+0.0007/-0.0000	0.0005
0.001/-0.0000	+0.0008/-0.0000	0.0006
0.0011/-0.0000	+0.0009/-0.0000	0.0007

These tolerances should be applied to the nominal bearing O.D.

MIL-HDBK-1599A

REQUIREMENT 202

Table 202-VII. Recommended shaft-and housing fits for mounting  
 MS27642 (KP-B, & MK-B); MS27648 (KP-BS- & MKP-BS);  
 MS27644 (Egoo & MB-500).

Dimensions in  
inches

BEARING NUMBER	FOR STEEL SHAFTS						HOUSING FITS					
	BEARING BORE		SHAFT O.D.		RESULTING FIT		BEARING BORE		SHAFT O.D.		RESULTING FIT	
	MAX.	MIN.	MAX.	MIN.	TIGHT	LOOSE	MAX.	MIN.	MAX.	MIN.	LOOSE	TIGHT
KP16B	1.0000	0.9995	0.9995	0.9990	0.0000	0.0010	1.7500	1.7490	1.7510	1.7500	0.0020	0.0000
KP16BS	1.0000	0.9995	0.9995	0.9990	0.0000	0.0010	1.9375	1.9365	1.9385	1.9375	0.0020	0.0000
KP21B	1.3130	1.3120	1.3120	1.3110	0.0000	0.0020	2.0625	2.0615	2.0635	2.0625	0.0020	0.0000
KP21BS	1.3130	1.3120	1.3120	1.3110	0.0000	0.0020	2.2500	2.2400	2.2510	2.2500	0.0020	0.0000
KP23B	1.4380	1.4370	1.4370	1.4360	0.0000	0.0020	2.1875	2.1865	2.1885	2.1875	0.0020	0.0000
KP23BS	1.4380	1.4370	1.4370	1.4360	0.0000	0.0020	2.3750	2.3740	2.3760	2.3750	0.0020	0.0000
KP25B	1.5630	1.5620	1.5620	1.5610	0.0000	0.0020	2.3125	2.3115	2.3135	2.3125	0.0020	0.0000
KP25BS	1.5630	1.5620	1.5620	1.5610	0.0000	0.0020	2.5000	2.4990	2.5010	2.5000	0.0020	0.0000
KP29B	1.8130	1.8120	1.8120	1.8110	0.0000	0.0020	2.5625	2.5615	2.5635	2.5625	0.0020	0.0000
KP29BS	1.8130	1.8120	1.8120	1.8110	0.0000	0.0020	2.7500	2.7490	2.7510	2.7500	0.0020	0.0000
KP33B	2.0630	2.0620	2.0620	2.0610	0.0000	0.0020	2.8125	2.8115	2.8135	2.8125	0.0020	0.0000
KP33BS	2.0630	2.0620	2.0620	2.0610	0.0000	0.0020	3.0000	2.9990	3.0010	3.0000	0.0020	0.0000
KP37B	2.3130	2.3120	2.3120	2.3110	0.0000	0.0020	3.0625	3.0615	3.0635	3.0625	0.0020	0.0000
KP37BS	2.3130	2.3120	2.3120	2.3110	0.0000	0.0020	3.2500	3.2490	3.2510	3.2500	0.0020	0.0000
KP47B	2.9390	2.9370	2.9370	2.9360	0.0000	0.0020	3.8750	3.8740	3.8760	3.8750	0.0020	0.0000
KP47BS	2.9380	2.9370	2.9370	2.9360	0.0000	0.0020	4.1250	4.1240	4.1260	4.1250	0.0020	0.0000
KP480S	3.0000	2.9990	2.9990	2.9880	0.0000	0.0020	4.2500	4.2490	4.2510	4.2500	0.0020	0.0000
KP49B	3.0630	3.0670	3.0670	3.0010	0.0000	0.0020	4.0000	3.9900	4.0010	4.0000	0.0020	0.0000
KP49BS	3.0630	3.0620	3.0620	3.0610	0.0000	0.0020	4.2500	4.2490	4.2510	4.2500	0.0020	0.0000
B538	0.6257	0.6243	0.6243	0.6233	0.0000	0.0024	1.0325	1.0615	1.0635	1.0625	0.0020	0.0000
B539	0.7507	0.7493	0.7493	0.7430	0.0000	0.0024	1.1875	1.1865	1.1886	1.1875	0.0020	0.0000
B450	0.8757	0.0743	0.0743	0.8733	0.0000	0.0024	1.3125	1.3115	1.3135	1.3125	0.0020	0.0000
B451	1.0632	1.0618	1.0618	1.0608	0.0000	0.0024	1.5000	1.4990	1.5010	1.5000	0.0020	0.0000
B542	1.3132	1.0118	1.0118	1.3108	0.0000	0.0024	1.7500	1.7490	1.7510	1.7500	0.0020	0.0000
B543	1.5632	1.5618	1.5618	1.5608	0.0000	0.0024	2.0000	1.9990	2.0000	2.0000	0.0020	0.0000
B544	1.8135	1.8115	1.8115	1.8105	0.0000	0.0030	2.2500	2.2405	2.2500	2.2500	0.0025	0.0000
B545	2.0635	2.0615	2.0615	2.0605	0.0000	0.0030	2.6250	2.6235	2.6250	2.6250	0.0025	0.0000
B546	2.3135	2.3115	2.3115	2.3105	0.0000	0.0030	2.8750	2.8735	2.8750	2.8750	0.0025	0.0000

For M Series use the same shaft O.D. and Housing bore dimensions

MIL-HDBK-1599A

REQUIREMENT 202

Table 202-VIII. Recommended housing fits for mounting AW-AK, DPP, DSP, psgp, GpSgp, pM, Kp, KP-A, KSP and P serie\* M828912 (DSRP&GDSRP); MS27647 (DW,GDW,MDW); M927641 (DP-A, MKP-A)! MS27640 (KP&MKP); MS27645 KS&MKSP

BEARING NUMBER				BEARING O.D.		STEEL HOUSING				DURAL OR MAGNESIUM HOUSING			
						HOUSING BORE		RESULTING FIT		HOUSING BORE		RESULTING FIT	
DSP (1)	(G)DSAP	KP		MAX.	MIN.	MAX.	MIN.	LOOSE	TIGHT	MAX.	MIN.	MIN.	MAX.
DPP,DW	KP-A	KSP	P,AW-AK									TIGHT	TIGHT
DW4K2	KP3 (3)	KSP3 (2)	AW3AK	0.6250	0.6245	0.6245	0.6240	0.0000	0.0010	0.6243	0.6238	0.0002	0.0012
DW4	KP3A	KSP4A	AW4AK	0.7500	0.7495	0.7495	0.7490	0.0000	0.0010	0.7493	0.7488	0.0002	0.0012
DPP3	KP3	KSP3	-----	0.7774	0.7769	0.7769	0.7764	0.0000	0.0010	0.7767	0.0776	0.0002	0.0012
-----	KP5A	KSP5A	AW5AK	0.8175	0.8120	0.8120	0.8115	0.0000	0.0010	0.8118	0.8113	0.0002	0.0012
DW5	KP6A	KSP6A	P4K (5)	0.8750	0.8745	0.8745	0.8740	0.0000	0.0010	0.8743	0.8738	0.0002	0.0012
DPP4(G)D	KP4 (6)	KSP4	-----	0.9014	0.9009	0.9009	0.9004	0.0000	0.0010	0.9007	0.9002	0.0002	0.0012
-----	-----	-----	PU5K	0.9375	0.9370	0.9370	0.9365	0.0000	0.0010	0.9368	0.9363	0.0002	0.0012
DW6	-----	-----	-----	1.0075	1.0670	1.0670	1.0615	0.0000	0.0010	1.0618	1.0613	0.0002	0.0012
-----	KP8A	-----	AW10AK	1.1250	1.1245	1.1245	1.1240	0.0000	0.0010	1.1243	1.1238	0.0002	0.0012
-----	-----	-----	P10K	1.1875	1.1870	1.1870	1.1865	0.0000	0.0010	1.1868	1.1863	0.0002	0.0012
DPP5(G)D	KP5	KSP5	-----	1.2500	1.2495	1.2495	1.2490	0.0000	0.0010	1.2493	1.2488	0.0002	0.0012
-----	KP10A	-----	AW10AK	1.3750	1.3745	1.3745	1.3740	0.0000	0.0010	1.3743	1.3738	0.0002	0.0012
DPP6	-----	-----	-----	1.4375	1.4370	1.4370	1.4365	0.0000	0.0010	1.4368	1.4363	0.0002	0.0012
DW8(G)D	KP6	KSP6	-----	1.4375	1.4370	1.4370	1.4365	0.0000	0.0010	1.4368	1.4363	0.0002	0.0012
-----	KP12A	-----	AW12AK	1.6250	1.6245	1.6245	1.6240	0.0000	0.0010	1.6243	1.6238	0.0002	0.0012
DPP8(G)D	KP8	KSP8	P8	1.6875	1.6870	1.6870	1.6865	0.0000	0.0010	1.6868	1.6863	0.0002	0.0012
DPP10(G)	KP10	KSP10	-----	1.9375	1.9370	1.9370	1.9355	0.0000	0.0010	1.9938	1.9363	0.0002	0.0012
-----	KP16A	-----	AW16AK2	2.0000	1.9995	1.9995	1.9990	0.0000	0.0010	1.9999	1.9988	0.0002	0.0012
-----	KP20A	-----	AW20AK	2.2250	2.2495	2.2495	2.2490	0.0000	0.0010	2.2493	2.2488	0.0002	0.0012

For M Series use same housing bore dimensions.

- |                                   |             |               |
|-----------------------------------|-------------|---------------|
| (1) Use fits shown for DPP Series | (2) And K3L | (3) And DW4-3 |
| (4) Also DW4-3 and DW4K           | (5) And P5K | (6) Also KP4K |

MIL-HDBK-1599A

REQUIREMENT 202

Table 202-IX. Recommended shaft and housing airframe roller bearing - torque tube type MS28915 (DAT).

RECOMENDED HOUSING BORE TOLERANCE

Limits in 0.0001 inch

Outside Diameter D (Inch)		Deviation From D				
		Steel		Light Alloy		Roundness
Over	Include	Low	High	Low	High	(TIR)
--	2	0	8	0	6	4
2	4	0	9	0	7	5
4	7	0	10	0	8	6

RECOMMENDED SHAFT  
TOLERANCE

Bore d (Inch)		Shaft Diameter Deviation From "d"	
Over	Include	Low	High
--	1	-10	-5
1	2	-13	-8
2	4	-16	-11

5.1.1 Bolted plate. Can be used with a shoulder in the housing to hold a bearing against thrust loads in either direction. This method can be used when an interference fit is not desired. Disadvantages are the required bolt holes and added weight and space requirements (see figure 202-3).

5.1.2 Anvil or roller staked bearing outer race. This method is used where the outer race is soft enough (RC24-36) to be deformed over a chamfer machined in the housing. The outer race has a special groove to facilitate operation. This method does not harm housing and permits unlimited replacement, of bearings. This method shall not be used with anti-friction bearings (see figure 202-4).

Groove depth	Anvil staking force	Push-out force	Anvil staking force	Push-out force
	(steel)	(steel)	(Aluminum bronze)	(Aluminum bronze)
0.03	17,400	3,000	7,200	1,200
0.04	18,200	3,475	7,500	1,400
0.06	@6,400	3,750	11,000	1,550
	Lbs. x Groove dia.	Lbs. x Bearing OD	Lbs. x Groove dia.	Lbs. x Bearing OD

MIL-HDBK-1599A

REQUIREMENT 202

5.1.3 Sleeve-staked or swaged. Full or split sleeve of aluminum is placed between bearings and enlarged bore of housing. Swaging the extended part of sleeve provides axial retention and radial tightness (see figure 202-5).

5.1.4 Roller swaged housing. Bearing housing is deformed by swaging rollers (surface speed of 40 to 150 ft/min) so that a section of the housing is forced into the chamfer on the edges of the bearing outer race (see figure 202-6).

5.1.5 Segment staked housing. A smaller ball or point, or a line die is pushed into the housing near the edge of the bearing, forcing the metal into the recess formed by the chamfer on the edge of the bearing and of the housing. This method is usually used with an interference fit of the bearing into the housing (see figure 202-7), and is the preferred method for anti-friction bearings.

NOTE: For groove staked bearing, the housing width and tolerance is the same as the outer race width and tolerance. For 3/16 to 7/16 bore bearings the chamfer depth is .020/.025 x 45.0. For all larger bearings the chamfer depth is .040/.045 x 45.0.

CAUTION

The preceding four retention methods require deformation of the bearing race or housing, and if improperly performed, they can damage the bearing components.

5.1.6 Adhesive bonding. The bearing may be placed against a shoulder in the housing. This method requires a clearance between the bearing and housing to establish a proper "bond line" thickness. Rigorous cleaning of the surface is essential. Several adhesive components are available. Anaerobic and epoxies are the most commonly used. If heat cured epoxies are used with aluminum bearings-or housings, care must be taken to assure that the temper of the aluminum is not affected.

5.1.7 Thread This retention technique requires a specially designed bearing with a flange at one race face to accommodate a threaded retention ring (see figure 202-8).

5.2 Proof testing. Most of the retention systems require metal deformation. If the staking is not done correctly, the retention capability may not be adequate. In cases where loss of retention strength may result in a catastrophic loss of a system, it may be desirable to perform a proof test on the staked bearing assembly. Proof tests should be performed at the design load for the assembly. The load should be maintained long enough so that any axial movement between the bearing and its housing ceases. Axial movement generally is acceptable if kept within prescribed limits dictated by the application. This is the preferred method for anvil staked bearings. This technique may also be required for arbor staked bearings in critical applications.

5.3 Station. When properly installed, bearings which have had the outer race roller staked over a housing chamfer shall exhibit the following characteristics:

- a. Any gap between the bearing's staked lip and housing chamfer shall not exceed .005 inches (see figure 202-9).

MIL-HDBK-1599A

REQUIREMENT 202

b. The bearings staked lips shall not exhibit cracks in the material. This includes a crack through the staked lip, a partial crack not through the lip, or a circumferential crack on the staked lip (see figure 202-10).

It is recommended that an illuminated magnifying glass or other suitable equipment be used when inspecting for these characteristics.

c. The bearings staked lip shall not exhibit deeply scratched, gouged, or score marks on the inner side or unstaked side of the bearing staking groove (see figure 202-11).

d. The bearings staked lip shall not be over-staked, that is, the staking lip shall not be feathered to a knife edge beyond the face of the housing (see figure 202-12).

e. Gouges, chips and dirt in the bearings staked lip are not acceptable. Minor impressions or contaminants, such as dust in the bearings staked lip are acceptable.

6. Bearing removal and replacement.

6.1 When a bearing has been retained in its housing by any of the techniques that require bearing or sleeve staking, removal of the deformed metal will be required before the bearing can be removed from the housing. The 8 machining operation must be performed carefully so that excess material will not be removed.

6.2 When a bearing is pushed out of the housing, it may score the ID. The degree of scoring will be determined by the interference conditions which exist and by the adequacy of removal of the staked metal.

6.3 In many instances, the scoring in the housing could result in fatigue problems and cannot be tolerated.

6.4 In cases where a bearing is assembled into its housing with clearance, the scoring will, in all probability, be minor and need only be removed by brush honing or polishing. The material removed should not increase the housing bore beyond the original blueprint requirements. If the scoring cannot be removed without causing the bore to go out of the original tolerance, the bore must be remachined to a new size, and either a special bearing must be refabricated to fit the new bore, or a staking ring should be installed with the bearing. Plating or hard anodize can also be used to restore the housing dimension. When polishing or re-machining chamfered housings, care must be taken to preserve the sharp edge at the bottom of the chamfer. The retention strength of the staked bearing is dependent upon these chamfers being sharp enough to "bite into" the staked bearing race. When an interrupted housing stake is used, it will be necessary to index the staking tool, so that during bearing replacement only virgin housing material will be staked.

6.5 Individual company policy may require MRB approval of any housing rework.

Table 202-X. Advantages of various bearing retention methods.

	<b>BOLTED PLATE</b>	<b>ANVIL OR ROLLER STAKED BEARING OUTER RACE</b>	<b>SLEEVE-STAKED OR SWAGED</b>	<b>ROLLER SWAGED HOUSING</b>	<b>BALL POINT/LINE STAKED HOUSING</b>	<b>ADHESIVE BONDING</b>
<b>Added space and weight</b>	High	None	Oversized bore needed	None	None	None
<b>Effect on bearing internal clearance</b>	None	None	None	High	Irregular	None
<b>Retention capabilities</b>	High	Medium	Staked-medium Swaged high	Medium	Low	High
<b>Introduction of residual stress in housing</b>	Low	None	None	High	High	None.
<b>Can replacement damage housing</b>	No	No	No	Yes	Yes	No
<b>Possible no. of bearing replacements</b>	No Limit	No Limit	No Limit	None	Three or more	No Limit
<b>Ease of installation</b>	Good	Fair	Fair	Poor	Good	Poor

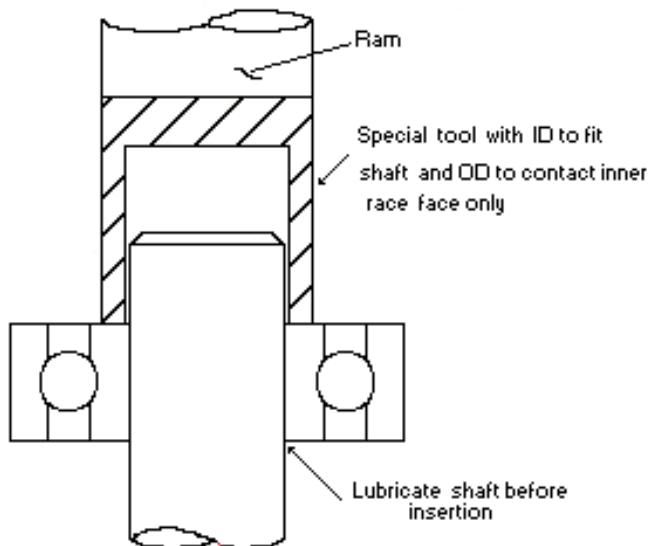


Figure 202-3. Bolted plate.

MIL-HDBK-1599A

REQUIREMENT 202

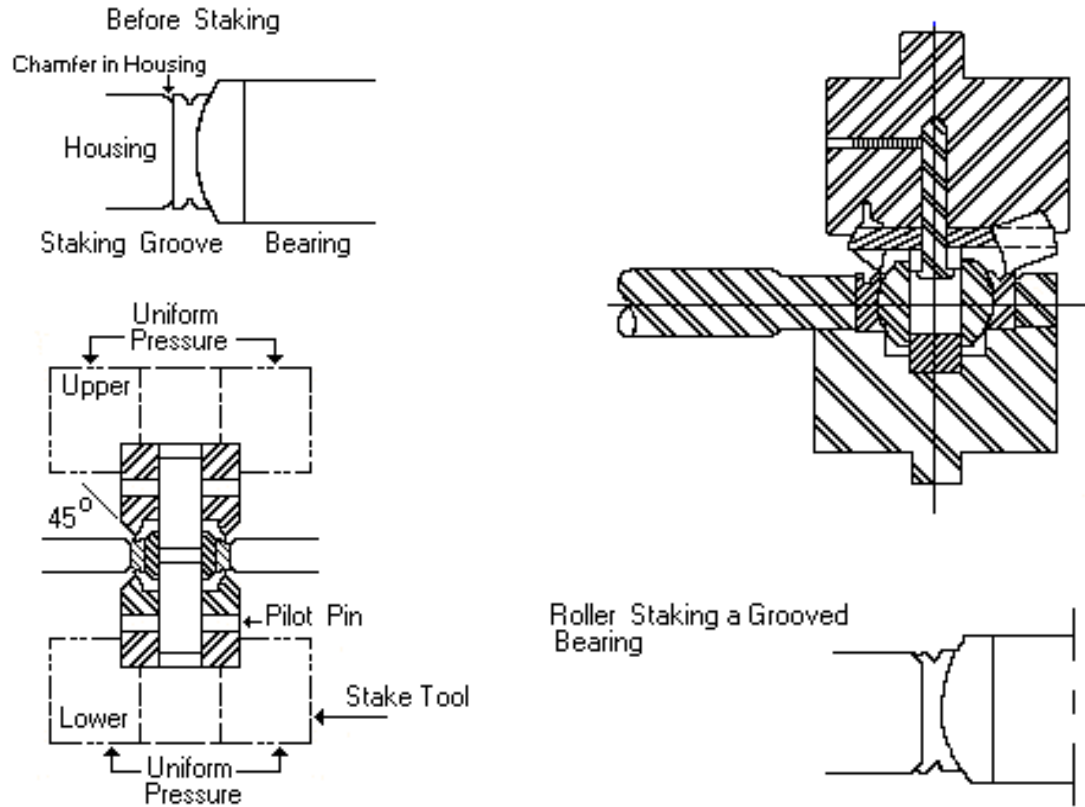


Figure 202-4. Anvil or roller staked bearing outer race.

MIL-HDBK-1599A

REQUIREMENT 202

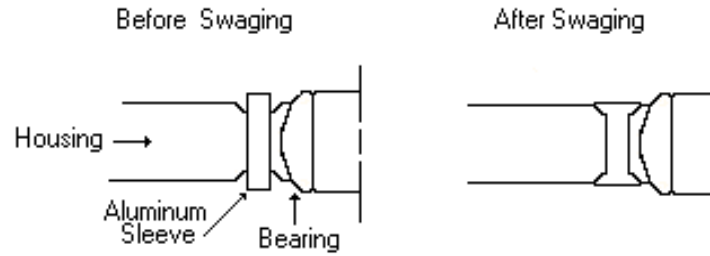
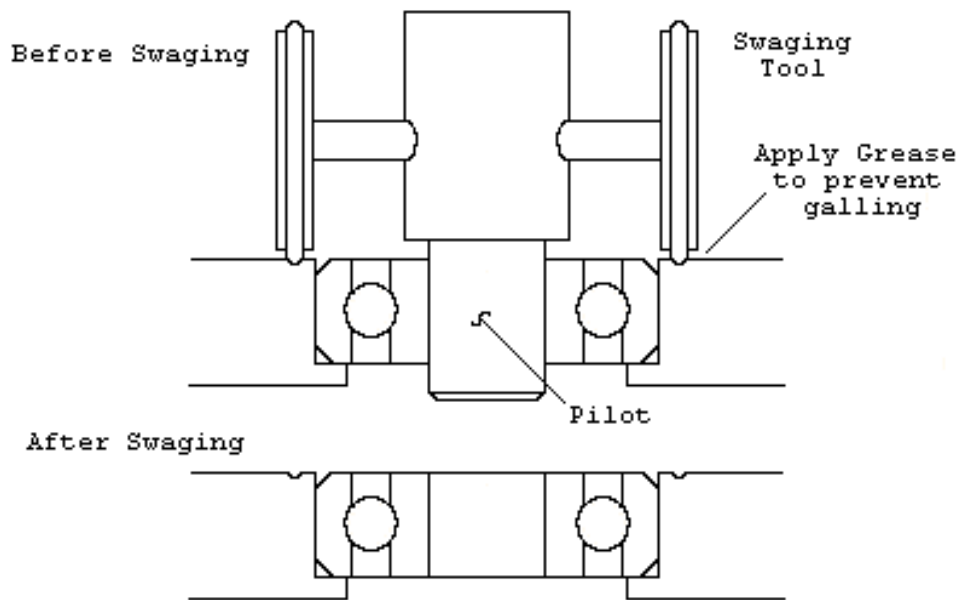


Figure 202-5. Sleeve staked or swaged.



Note: Both sides may be roller staked

Figure 202-6. Roller swaged housing.

MIL-HDBK-1599A

REQUIREMENT 202

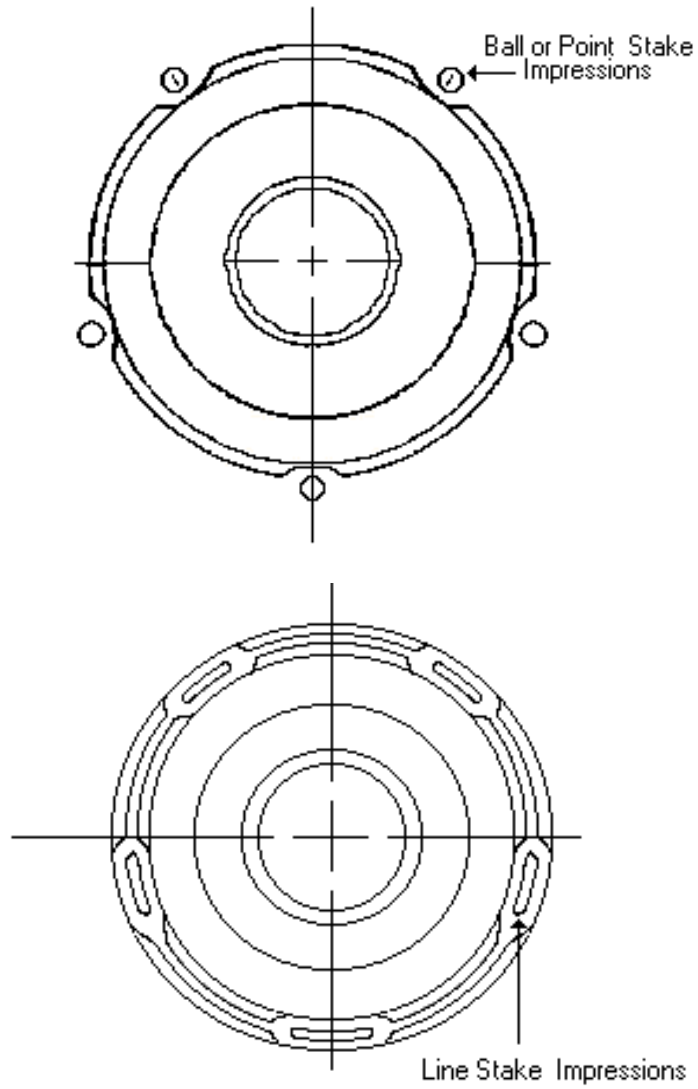
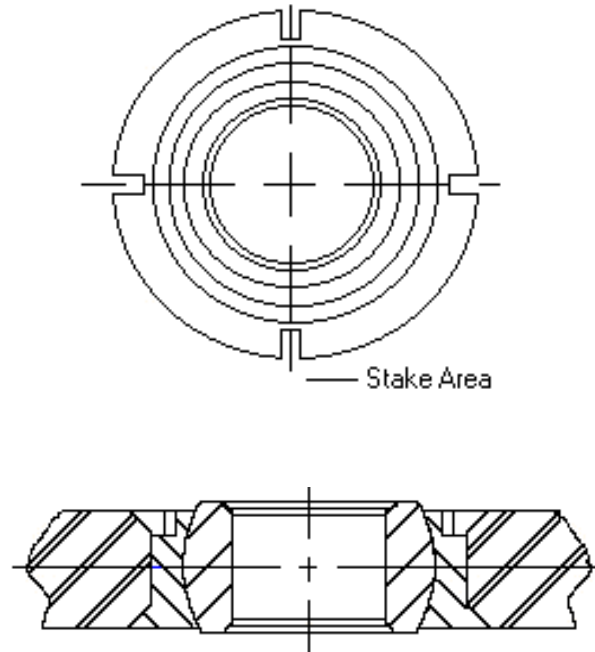


Figure 202-7. Segment staked housing.

MIL-HDBK-1599A

REQUIREMENT 202



NOTE: The flange and nut configurations are optional and need not be as shown.

Figure 202-8. Threaded ring.

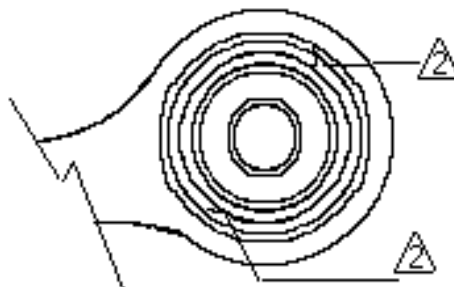


Figure 202-9. Gap between staked lip and housing chamfer.

MIL-HDBK-1599A

REQUIREMENT 202

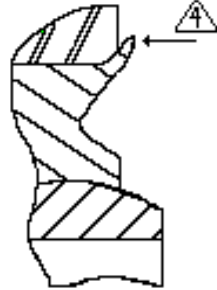


Figure 202-10. Cracks in staked lips.

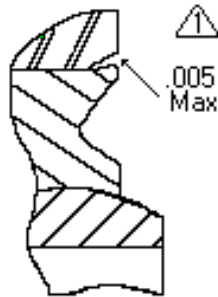


Figure 202-11. Scratched, gouged or score marks on staking groove.



Figure 202-12. Over-staking.

MIL-HDBK-1599A

REQUIREMENT 203

COMPONENT LUBRICATION

1. SCOPE.

1.1 Scope. This requirement establishes standard design practices for the lubrication of the bearings and bearing surfaces used in flight control systems and all other mechanical subsystems installed in airframes except engines and their Accessory drive gear boxes and helicopter transmission drive systems.

2. APPLICABLE DOCUMENTS.

2. 1 Government documents.

2.1.1 Specifications, standards, and handbooks. The following specifications, standards, and handbooks form a part of this document to the extent specified herein. Unless otherwise specified, the issue of these documents are those listed in the issue of the Department of Defense Index of Specifications and standards (DODISS) and supplement thereto, cited in the solicitation (see 6.2)

SPECIFICATIONS.

MILITARY

MIL-G-21164 Grease; Molybdenum Disulfide (for low and high temperatures)

MIL-G-23827 Grease; Aircraft and Instrument, Gear and Actuator Screw

MIL-G-91322 release; Aircraft, General Purpose, Wide Temperature Range

STANDARDS.

MILITARY

MIL-STD-838 Lubrication of Military Equipment

MS 15720 Fittings, Lubrication (Hydraulic) Throat or Surface Check, 1/4 - 28  
Taper Threads, Corrosion-Resistant Steel, Type VII

HANDBOOK

MILITARY

MIL-HDBK-275 Guide for Selection of Lubricant Fluids and Compounds for  
Use in Flight Vehicles and Components

(Unless otherwise indicated, copies of federal and military specifications, standards, and handbooks are available from the Naval Publications and Forms Center, (ATTN: NPODS), 5801 Tabor Avenue, Philadelphia, PA 19120-5099.)

2.1.2 Other Government documents, drawings, and publications. The following other Government documents, drawings, and publications Form a part of this document to the extent specified herein. Unless otherwise specified, the issues are those cited in the solicitation.

MIL-HDBK-1599A

REQUIREMENT 203

DODISS - Department of Defense Index of Specifications and Standards.

(Copies of the DODISS are available on a yearly subscription basis either from the Government Printing office hard copy, or microfiche copies are available from the director, Navy publications and Printing Service Office, 700 Robins Avenue, Philadelphia, PA 19111-5093.)

2.2 Non-Government publications. This paragraph is not applicable to this requirement.

2.3 Order of Precedence. In the event of a conflict between the text of this document and the references cited herein, (except for related associated detail specifications, specification sheets, or MS standards), the text of this document takes precedence. Nothing in this document, however, supersedes applicable laws and regulations unless a specific exemption has been obtained.

3. DEFINITIONS.

3.1 Lubricant. The term lubricant as stated herein is defined as any solid, fluid or semi-fluid material that performs a lubricating or related specialty function.

3.1.1 Standard lubricant. A standard lubricant as stated herein is defined as a lubricant qualified or procured in accordance with Federal or Military specifications or official purchase descriptions as listed in MIL-HDBK-275; C-6800-IL, Chemical and Chemical Products, Identification List; and C-9100-IL, Fuels, Lubricants, Oil and Waxes, Identification List.

3.1.2 Non-standard lubricant. A non-standard lubricant as stated herein is defined as a lubricant procured on a brand or trade name basis, without reference to a federal or military specification, or to a purchase description.

4. GENERAL REQUIREMENTS.

4.1 Lubrication applications. All bearings and bearing surfaces which require lubrication during the design life of its installation, will have provisions made so that lubrication can be performed with the minimum of aircraft disassembly and the minimum of support equipment consistent with mission requirements and the resulting limitations of space and weight.

5. DETAIL REQUIREMENTS.

5.1 Lubricant selection. Whenever possible, standard lubricants shall be used in accordance with MIL-STD-838 and MIL-HDBK-275. In those instances where non-standard lubricants are required, their usage shall be in accordance with MIL-STD-838.

5.1.1 Lubricant recommendation.

5.1.1.1 Rolling element anti-friction bearings. Rolling element anti-friction-bearings shall be lubricated with either the preferred MIL-G-81322 or MIL-G-23821 grease depending upon the environmental operating temperature of the installation.

MIL-HDBK-1599A

REQUIREMENT 203

5.1.1.2 Gear boxes. Gear boxes shall be lubricated in accordance with the requirements of the performance acquisition document.

5.1.1.3 Sliding element bearing. Sliding element bearings shall be permanently lubricated or shall be capable of being relubricated with a grease. For grease lubrication, either MIL-G-21164, MIL-G-23827, or MIL-G-81322 is recommended. Permanently lubricated bearings shall be lubricated with a solid lubricant containing polytetrafluoroethylene(PTFE) in some form of liner system.

5.2 Periodic lubrication. For those installations requiring periodic lubrication, the requirements of MIL-STD-838 shall apply.

6. NOTES

6.1 Intended use. This requirement is intended to establish standard design practices for the lubrication of the bearings and bearing surfaces used in flight control systems and all other mechanical subsystems installed in airframes except engines and their accessory drive gear boxes and helicopter transmission drive systems.

6.1.1 Provisions for lubrication.

6.1.1.1 Unsealed rolling element bearings. Unsealed rolling element bearings protected by an enclosure and periodically serviced with a proper lubricant unless they receive adequate lubrication from the lubricant of the unit in which they are installed.

6.1.1.2 Sealed rolling element bearings. Rolling element bearings which are permanently sealed are considered to be lubricated for the life of the bearing, unless a means of relubrication is provided. Rolling element bearings with replaceable seals shall be considered to be permanently lubricated for the life of the installation, unless service experience demonstrates the need for periodic lubrication.

6.1.1.3 Lubrication fittings. Insofar as possible, provisions for lubrication and access to lubrication fittings shall not require the removal of adjacent fittings, structure, or the use of specialized equipment.

6.1.1.4 Recommended lubrication fittings. The recommended lubrication fittings to be used for grease lubrication are described in requirement 501.

6.2 Issue of DODISS. When this requirement is used in acquisition, the issue of the DODISS to be applicable to this solicitation must be cited in this solicitation (see 2.1.1 and 2.2).

MIL-HDBK-1599A

REQUIREMENT 204

SAFETYING PRACTICES

1. SCOPE. This requirement states general methodology for safetying practices to be used in flight control systems. This requirement specifically delineates approved safetying methods and devices and specifies the application of these methods and devices. This requirement covers only those devices whose primary function is safetying, and excludes those devices which have integral locking features incorporated into the item being locked. Since safetying and retention occasionally become coincident functions, a fine distinction must be made between the two. Refer to requirements 202, 206, 207, 208, 401, 402, 601 and 604 for additional methods and devices which may provide a safetying function coincident with a retention function. Special applications involving conditions not covered by the basic principles described herein shall be shown on the assembly drawing, and where contradiction occurs between a drawing and these instructions, the drawing shall take precedence.

2. APPLICABLE DOCUMENTS.

MIL-T-8878	Turnbuckle, Positive Safetying
MS 20995	Wire, Safety or Lock
MS 21251	Turnbuckle Body, Clip Locking
MS 21252	Clevis, Rod End; Turnbuckle, Clip Locking
MS 21253	Clevis End, Turnbuckle, Clip Locking (For bearing)
MS 21254	Eye End, Turnbuckle, Clip Locking (For pin)
MS 21255	Eye End, Turnbuckle, Clip Locking (For wire rope)
MS 21256	Clip, Locking, Turnbuckle
MS 24665	Pin, Cotter, (split)
MS 33540	Safety Wiring and Cotter Pinning, General Practices for
MS 33736	Turnbuckle Assemblies, Clip Locking of

3. USAGE AND DESIGN.

3.1 Preferred usage. The preferred methods of preventing rotation and loss of nuts, bolts, or screws are:

- a. Use of self-looking bolts, screws, nuts, and inserts. (See requirement 402)
- b. Use of cotter pins with castellated nuts.
- c. Use of safety wire and drilled head bolts or screws.

In assemblies that may require periodic removal, where possible use either self-looking nuts or castellated nuts to be looked with cotter pins. Turnbuckle clips shall be used for positive safetying or turnbuckle components. Rod end bearings used in control rods shall be safetyed as noted in requirement 207. Safetying of push-pull controls shall be as specified in requirement 208 and safetying of control cable components such as quick disconnects, cable take-up links and terminals shall be as specified in requirements 206 or 601.

MIL-HDBK-1599A

REQUIREMENT 204

3.2 Cotter pins.

3.2.1 Cotter pins are generally used to restrain relative motion between two parts by inserting the cotter pin through a hole in one part and slots in the other part and spreading the exposed ends. Their use is favorable because they can be installed and removed quickly. Cotter pins shall be used:

- a. With castellated nuts and drilled bolts and screws to insure nut retention.
- b. With self-locking castellated nuts and drilled bolts and screws to provide dual locking feature.
- c. As a retaining device on pins or shafts.

3.2.2 Applicable cotter pin design standard. Design standard MS33540 shall be used for design practices, functional limitations and installation procedures. The selection of materials shall be made from MS24665 and shall be in accordance with temperature, atmosphere and service limitations given in MS33540.

3.3 Safety wiring.

3.3.1 Safety wiring usage. Safety (lock) wiring is the securing together of two or more parts with safety wire which shall be installed in such a manner that any tendency for a part to loosen will be counteracted by additional tightening of the wire. Safety wire (lock wire) shall be used:

- a. To prevent the loosening of threaded parts in applications where other locking means such as cotter pins, key (bent tab) washers, self-locking fasteners, etc. would not be feasible.
- b. In the case of single attachment bolts used head-down where loss of the bolt would affect safety of flight the bolt shall be safety wired through the head of the bolt to retain it in place following loss of the nut; unless otherwise restrained in position by means that are independent of the attaching nut.
- c. To prevent the loss of disconnected items such as caps, plugs, etc.
- d. To secure valve handles and external snap rings.

CAUTION

Safety wire should not be used to retain parts or limit the amount of motion between parts in applications where relative motion is normal since this will cause cold working and failure of the safety wire.

MIL-HDBK-1599A

REQUIREMENT 204

3.3.2 Applicable safetying wire design standards. Design standard MS 33540 shall be used for design practices, functional limitations, preferred material usage, installation procedures and all other requirements. MS 20995 lockwire referenced therein is the approved part callout.

3.4 Turnbuckle Clips.

3.4.1 Turnbuckle clip usage. Turnbuckle clips are used to prevent rotational movement between the turnbuckle body and the turnbuckle-end. They can be installed manually without the use of tools and are self-retained in the assembly.

3.4.2 Applicable turnbuckle clip design standards. Design standards MS21251, MS21252, MS21253, MS21254, M321255, MS21256 and procurement specification MIL-T-8878 shall be used for design practices, functional limitations, and material usage. Design standard MS33736 shall be used for installation procedures of the turnbuckle assembly. M321256 looking clip referenced therein is the approved part callout.

MIL-HDBK-1599A

REQUIREMENT 205

#### BALL SCREW USAGE

Although initially included in this military standard, ball screw usage has been determined to be outside the scope of this document. Ball screws are an actuation system rather than a component. They provide power to cause the translation or rotation of other components. Accordingly, they are an "active" system rather than a "passive" component. This document is for passive components which transmit power or motion in aircraft control systems but which do not produce power.

MIL-HDBK-1599A

REQUIREMENT 206

## CONTROL CABLE SYSTEM DESIGN REQUIREMENTS

1. SCOPE. This requirement establishes engineering criteria and requirements for the selection and application of mechanical controls system cable and components. This requirement is limited to components selection and does not establish selection criteria for control cable systems relative to sizing, tensioning, actuating and similar system oriented design requirements. This document is .not intended to address cables used as static structural members nor as means of transferring operating loads in structural/functional systems such as winches. Push-pull control cable requirements are included as requirement 208. Approved components for cable assemblies and systems are listed in appropriate requirements in section 600.

### 2. APPLICABLE DOCUMENTS.

MIL-T-781	Terminal, Wire Rope, Swaging
MIL-C-5688	Cable Assemblies, Aircraft, Proof Testing and Prestretching of
MIL-T-6117	Terminal, Cable Assemblies, Swaged Type
MIL-P-7034	Pulleys, Groove, Antifriction Bearing, Grease Lubricated, Aircraft
MIL-T-8878	Turnbuckle, Positive Safetying
MIL-F-9490	Flight Control Systems-Design, Installation and Test of Piloted Aircraft, General Specification for
MIL-C-16173	Corrosion-Preventive Compound, Solvent Cutback, Cold-Application
MIL-F-18372	Flight Control Systems: Design, Installation and Test of, Aircraft (General Specification for)
MIL-W-83420	Wire Rope, Flexible, For Aircraft Control
MS20392	Pin, Straight, Headed-Drilled Shank
MS20663	Ball End, Wire Rope, Swaging, Double Shank
MS20664	Ball End, Wire Rope, Swaging, Single Shank
MS21256	Clip, Looking, Turnbuckle
MS33602	Bolts, Self-Retaining, Aircraft Reliability and Maintainability, Design and Usage, Requirement for
MS33736	Turnbuckle Assemblies, Clip Locking of
MIL-STD-1515	Fastener Systems for Aerospace Applications
NAB 302 - NAB 310	Cable Assembly, Swaged Type, Type I Terminals
NAB 312 - NAB 320	Cable Assembly, Swaged Type, Type I & Type II Terminals
NAB 322 - NAB 330	Cable Assembly, Swaged Type, Type 11 Terminals
NAB 427	Pin-Pulley Guard
NAB 1435	Terminal, Strap, Cable (Eye End and Fork End)

### 3. DESIGN REQUIREMENTS.

3.1 Control cable assembly requirements. The requirements set forth in this paragraph apply to mechanical wire-rope-type cable systems used in primary, secondary and auxiliary control cable systems.

MIL-HDBK-1599A

REQUIREMENT 206

3.1.1 Control cable material.

3.1.1.1 Bare cable. All control cable used in primary, secondary, and auxiliary control systems shall conform to MIL-W-83420, type I, composition A or B.

3.1.1.2 Lockclad cable. Cable onto which aluminum or steel tubing is swaged for basically the entire length or a high percentage of the length may be used in primary, secondary or auxiliary controls systems. Cable which forms the core of the lockclad cable shall conform to MIL-W-83420, type I, composition A or B. The contractor shall be prepared to show the customer from vendor data or design handbook tabulations based on test or experience that the lockclad material and diameter will provide the appropriate EA values and thermal coefficient of expansion used for the application.

3.1.1.3 Non-metallic material jacketed cable. Cable which is jacketed with non-metallic tubing may be used in primary, secondary, and auxiliary controls systems. Jacketed cable shall conform to MIL-W-83420, type II, composition A or B.

3.1.1.4 Cable type selection. Bare, lockclad and nonmetallic material jacketed cable as noted above may be used in all applications except as restricted herein or as required by specific contracts. Primarily because of weight, lockclad should be used only where stretch of bare cable must be reduced.

3.1.1.5 Cable material selection. Unless otherwise required in the specific contract, MIL-W-83420, type I or II, composition B, or lockclad using type I cable as the core should be considered for all applications in a potentially corrosive environment and in all landing gear wheel wells or other applications subject to runway debris.

3.1.2 Control cable terminals.

3.1.2.1 Attachment to cable. All terminals on cable used in primary or secondary controls systems which attach directly to the cable at the ends or any other point shall be attached to the cable by swaging per the requirements of MIL-T-6117. Terminals swaged to lockclad cable shall be swaged to bare cable except the special condition where by the lockclad extends the entire length of the cable assembly. Type III terminals as described in requirement 601 may be swaged over the cladding. Jacket material shall be removed in the area of the terminal prior to swaging. Terminals attached to cables used in auxiliary controls systems shall be swaged per MIL-T-781 except that crimped type terminals with or without loops may be used in cable assemblies such as lanyards. Caution: cladding shall never be removed from lockclad cable. Stripping of cladding is disallowed. Lockclad cable assemblies shall be manufactured with gaps in the cladding for all areas which will go around pulleys, receive terminals, or where a bend of more than 2 degrees is inherent in the application.

3.1.2.2 Approved terminals. Only the terminals specified in requirement 601 may be considered approved for use in design.

MIL-HDBK-1599A

REQUIREMENT 206

3.1.2.3 Approved cable assemblies. NAS 302 - NAS 330 cable assemblies are approved for use within the restrictions set forth herein. cable assemblies manufactured in accordance with this requirement using terminals approved in requirement 601 may be detailed and identified by airframe or cable assembly manufacturer, a part numbers without further approvals by authority of. MIL-HDBK-1599.

3.1.2.4 Terminal usage. Usage of terminals shall comply with the following:

a. Swaged/non-threaded terminals. Types I and III terminals as noted in requirement 601 may be used in primary, secondary and auxiliary controls systems. Type II terminals are approved only in secondary and auxiliary controls systems except as noted in paragraph b. Type IV terminals are approved only for items such as lanyards.

b. Ball end terminals. MS 20663 and MS 20664 ball end terminals may be used in primary controls systems to attach cable assemblies to bellcranks and quadrants. Ball end terminals with NAS 1435 straps may be used only in secondary or auxiliary-controls systems. Balls without shanks may-be used-in auxiliary controls systems only when used as a terminal. Balls without shanks may be used in secondary or auxiliary controls systems at points other than the ends of the assemblies for purposes of operating limit switches or other non-structural functions. Swaged plugs may be used as terminals only in auxiliary controls or cable systems, such as static lines for paradropping.

c. Swaged/threaded terminals. Terminals which are swaged to the cable and threaded on the non-swaged end shall be limited to those types used with turnbuckles or through components with a connection free to align with the cable direction. Control cables assemblies shall not be attached to equipment, bellcranks, etc., by threading into open o" closed-end tapped holes. Chain to cable swaged fittings-shall be attached by stud (clevis pin) and cotter pin.

d. Cable end. All cable assemblies shall terminate at both ends with swaged terminals. Cable assemblies shall not terminate in out cable ends beyond the extent of normal protrusion beyond terminals noted in terminal swaging specifications or terminal drawings.

e. Design for installation. Cable assemblies shall not be applied such that swaging of terminals is required after cable assembly is mounted in aircraft.

f. Crimped terminals and loops. Crimped type terminals (type IV) with or without loops shall be used only for non-critical auxiliary applications such as lanyards.

3.1.3 Control cable assembly strength criteria.

3.1.3.1 Control cable associated components. All terminals, pins; bolts, nuts, or other items attached directly-to the loaded cable shall be structurally capable of withstanding the minimum breaking strength of the cable. This applies both in attachment to or connection with the cable and physical construction of parts. The exception to this requirement is a component specifically designated to fail prior to loads which may damage equipment in auxiliary systems only. Ball terminals without shanks and plug terminals shall not be considered to withstand more than 80 percent of cable strength and shall be used only in auxiliary cable systems.

MIL-HDBK-1599A

REQUIREMENT 206

3.1-3.2 Lockclad and Jacketed cable. Strength criteria shall be based on the wire rope strength only, even when type III terminals are used with lockclad cable.

3.1.4 Control cable-to-cable connections.

3.1.4.1 Clevis/eye connections. Control cable assemblies may be connected by clevis and eye terminals with bolt/nut attachment, Safetied as specified in requirement 601. Secondary and auxiliary control cable systems may be connected by US20663 and NAS 1435-terminals with bolt/nut attachment, safetied as specified in requirement 601.

3.1.4.2 Turnbuckles and terminals. Cables may be connected by threaded fittings and turnbuckles. Assembly shall be accomplished per MS33736. In addition, when using aluminum turnbuckles, all male threads shall have MIL-C-16173, grade 2 or 4, corrosion preventive compound applied before assembly. Regardless of material, there shall be no more than three threads on either terminal exposed after assembly and adjustment of turnbuckle assemblies. After complete assembly of the turnbuckle assembly and installation of the clip, MIL-C-16173 corrosion-preventive compound shall be applied to the whole assembly. All turnbuckle terminal assemblies shall be safetied per MS33736 using MS21256 clips. The military wrap system is not approved for use on aerospace systems whereby MIL-HDBK-1599 is a requirement.

3.1.4.3 Cable take-up links. Cable take-up links may be used in primary or secondary controls or auxiliary cable systems where course adjustment is required. The link shall mate with two threaded or swaged eye and terminals. The link is assembled by placing the side plates on both sides of the eye end terminals of the cable assemblies to be joined and placing the bolts through the plate, eyes, and plate, and installing the nuts oh the bolt. The link therefore provides the capability of lengthening or shortening cable runs in amounts greater than turnbuckle adjustment spans. The link shall be safetied by either the use of self-retaining bolts or the use of self-looking castellated nuts with cotter pins. No other safeying is required, but may be added at the option of the airframe manufacturer.

3.1.4.4 Clad-to-clad connections. Type III internal and external terminals may be used in primary, secondary, or auxiliary control cable systems for connection of two lockclad cable assemblies whereby the cladding extends to the end of the cable assembly. Safeying shall be accomplished as noted in requirement 601.

3.1.4.5 Quick disconnects. Quick disconnects utilizing MS20663 and MS20664 ball ends are not approved for primary control systems. They may be used in secondary controls or auxiliary cable systems. Quick disconnects which are swaged onto cable or thread to approved terminals may be utilized on all systems, but must meet all requirements of swaged or threaded terminals as specified herein. Swaging shall be in accordance with MIL-T-6117 or MIL-T-8878, as applicable. Quick disconnects using the ball type terminals do not require safeying. All quick disconnects used in primary control systems require safeying as shown in requirement 601.

MIL-HDBK-1599A

REQUIREMENT 206

3.2 Design usage requirements of control cable assemblies.

3.2.1 Loading.

3.2.1.2 Sizing and material. Control cable material and sizing shall be in accordance with the following in addition to requirements of MIL-F-9490 or MIL-F-18372 as applicable:

- a. Cable material shall be either MIL-C-83420, type I or II, composition A or B as specified in the model specification for the aircraft. If the model specification does not specify the material, type I or II, composition B should be considered for all cable located in a corrosive environment or subject to runway debris.
- b. Lockclad cable is intended for the purpose of reduction of tensile stretch and matching the thermal coefficient of expansion of the cable more nearly to that of the aluminum airframe structure. While the cladding adds to the strength of the cable assembly, no structural credit shall be given to the added strength of the clad material in design considerations.
- c. Loop type termination of cables shall be considered no greater than 80 percent of the cable ultimate strength for loading determinations.

3.2.2 Control cable routine and support.

3.2.2.1 Support. Control cable shall be supported by pulleys at all points whereby the direction is changed 2 degrees or more when the rig load is less than 50 pounds and 1 percent when the rig load is 50 pounds or greater. Control cable shall be supported by fairleads at least every 100 inches of length unsupported by pulleys and in any location where "slap" may contact structure. Cable shall be supported by pulleys or fairleads on at least one side of any bulkhead through which the cable passes. Design shall be such that lockclad is not required to bend over fairleads or pulleys and such that maximum bend due to weight of lockclad or tolerances of mounting is not greater than 2 percent.

3.2.2.2 Location relative to structure. Cable shall be routed and connection points located such that sufficient clearance is provided to prevent fouling of fittings or damage to structure, equipment, or cable due to structural deflection, thermal expansion, tolerance accumulation, functioning equipment, or other factors. Where cable passes through holes in bulkheads or the possibility of contact with structure or fixed equipment exists, fairleads shall be provided.

3.2.2.3 Fairleads. Anti-friction fairleads shall be used for support of cables for purposes of sag reduction and general support. Fairlead strips may be used in auxiliary cable systems only for protection of structure and cables where peculiar designs may allow contact of the cable with structure or equipment. When anti-friction fairleads are used in opposition, the space between opposing flanges shall be less than 1/4 and more than 1/8 diameter of the cable. Fairlead roller installation should be such that cable does not vibrate within the space between opposing fairleads, such as by staggering fairleads. Approved fairleads are listed in requirement 603.

MIL-HDBK-1599A

REQUIREMENT 206

3.2.2.4 Pulleys and brackets. Pulleys shall conform to requirement 603. Sizes shall conform to MIL-P-7034 and associated MS documents. Pulleys shall be aligned with the cable run such that axial pull-off angle is not greater than 2 degrees in either direction off center line of pulley groove. Pulley guard pins shall be NAS 427 or M320392 types. NAS 427T cantilever type pins shall not be used- in lengths greater than 2 1/2 inches when unsupported at one end. Where angle of wrap is 20 degrees or less, one guard pin is required; 20 degrees to 120 degrees, 2 are required; and over 120 degrees, 3 are required. Pulley brackets shall be attached to primary structure only. Ratio of cable diameter to pulley diameter of 20:1 or greater should be considered for enhancing fatigue life of cables.

3.2.2.5 Cable connection locations. Care shall be exercised in locating cable connections to assure that cable assemblies and connecting components, (turnbuckles, cotter pins, safety wire, quick disconnects, links, etc.), cannot snag on each other or surrounding structure or equipment. Turnbuckles shall be staggered to prevent crossrigging.

3.2.2.6 Bellcrank or structure-termination. Terminations into bellcranks or structure shall be aligned such that the cable does not misalign relative to the swaged terminal more than 2 degrees. Swivel arrangements may be used to circumvent misalignment.

3.2.3 Fasteners used in control cable systems.

3.2.3.1 Bolt and nut selection.

3.2.3.1.1 Structural requirement. Selection of bolts and nuts shall be in accordance with the structural requirements of the specific application and the requirements of this standard.

3.2.3.1.2 Approved bolts and nuts. Parts listed in MIL-STD-1515 are considered approved parts herein.

3.2.3.1.3 Retention requirement. Each removable bolt, screw, nut, pin, or other removable fastener, the loss of which would preclude or impair continued safe flight, shall incorporate two separate locking or retention devices either of which must be capable of preventing loss of the fastener by itself and retain it in its proper installation with the other locking or retention device missing, failed, or malfunctioning. Clevis pins shall not be used. Clevis bolts with shear castle nuts and cotter pins are considered satisfactory in shear applications as one of the two methods of retention. Bolts of less than 1/4 inch diameter shall not be used for critical applications as the single attachment. Where self-retaining bolts are used and which constitute one of the two retention methods, their selection and installation shall be within the limitations of MS33602, and only one type shall be used in any given system. Provisions for prevention of over-torquing bolts and thereby causing binding of other control system components shall be considered and appropriate precautions taken. Bolts mounted head down shall be self-retaining type bolts or have heads safety wired to structure or other components to prevent loss of bolt if nut is loose.

3.2.3.2 Cotter pins-and studs. Parts approved in MIL-STD-1515 may be used herein. Special pins for type III terminals shall be per requirement 601.

MIL-HDBK-1599A

REQUIREMENT 206

3.2.4 Pressure seals. Pressure seals shall be used with the following conditions:

a. Pressure differential. Pressure seals approved in requirement 605 shall be used if system pressure differential requirement can be met. If not, a seal shall be designed or selected by the contractor. If a vendor-identified seal is selected, it must be submitted for approval per requirement 101. If the seal is designed by the contractor, it is outside the scope of this document.

b. Alignment. Alignment of the cable through the seal shall be within 2 degrees of the center line of the seal during all operating positions of the cable travel.

3.3 Test requirements.

3.3.1 Control cable assemblies. Control cable assemblies shall be tested as follows:

a. All cable assemblies manufactured with swaged terminals shall be proof loaded to 60 percent of ultimate cable strength per MIL-C-5688.

b. Cable assemblies shall be loaded to ultimate strength as required by MIL-T-6117. Cable assemblies loaded to ultimate strength per this requirement shall not be Used on aircraft.

c. There shall be no broken wires in cable assemblies as required by MIL-W -83420.

4. QUALITY ASSURANCE PROVISIONS.

4.1 Control cable assemblies.

4.1.1 Lubricant removal. Cleaning processes used by airframe manufacturers shall not remove internal lubrication of cable applied by the cable manufacturer.

4.1.2 Turnbuckle clips. M321256 clips shall not be used more than once. When readjusting turnbuckles, removed clips shall be discarded and new clips used for safetying.

5. DESIGN, SELECTION AND APPROVED CALLOUT. (see requirements section 600 for approved parts).

6. TOOLING. There are no special tooling requirements.

7. INTENDED USE AND CRITERIA.

7.1 The purpose of this requirement is to establish required criteria. Where there are no requirements in a specific area and guidance information may be included, the lack of requirements is so noted.

MIL-HDBK-1599A

REQUIREMENT 206

8. NOTES.

8.1 Equipment. Actuators, tension regulators, servos, bellcranks, and other control system equipment are not in the scope of MIL-HDBK-1599. Interfaces of this equipment with cable or push-pull controls; however, must comply with the requirements herein as applicable.

8.2 Swaged fittings other than termination. Fittings such as plugs or no-shank balls which are swaged onto cable as an additional fitting to the two terminals may be used for triggering limit switches, or other applications of this nature, but shall not be used to transmit loads to or from the cable system.

8.3 Specially designed fittings. Swaged fittings designed specifically for use as cutters or for other functions must be approved per the procedure in requirement 101.

MIL-HDBK-1599A

REQUIREMENT 207

CONTROL ROD SYSTEM

1. Scope. This requirement establishes engineering criteria and requirements and application of rigid rods or tubes used for transferring linear motion in the controls and other functional systems and requirements for associated hardware. This requirement is not seeped to determine load requirements for systems, sizing and material selection for rods, or rigid rods used as structural components. Approved rod components are listed in requirement 602 and the various bearing requirements specified herein.

2. Applicable Documents.

FED-STD-245	Tolerances for Aluminum Alloy and Magnesium Alloy Wrought Products
MMM-A-1754	Adhesive and Sealing Compound, Epoxy, Metal Filled
WW-T-700/3	Tube, Aluminum Alloy, Drawn, Seamless, 2024
MIL-S-8879	Screw Threads, Controlled Radius Root With Increased Minor Diameter; General Specification for
MIL-T-6845	Tubing, Steel, Corrosion-Resistant (304), Aerospace Vehicle Hydraulic System, 1/8 Hard Condition
MIL-R-6088	Heat Treatment of Aluminum Alloy
MIL-H-6875	Heat Treatment of Steels, Process for
MIL-F-7179	Finishes and Coatings; Protection of Aerospace Weapons Systems, Structures, and Parts
NAS 513	Washer, Rod End Looking
NAS 1193	Looking Device, Positive Index

3. Design requirements.

3.1 Rod material and construction

3.1.1 Material selection. The material shall be selected based on the loading requirements of the system. Magnesium is hereby prohibited because of its corrosion characteristics. Otherwise there are no restrictions on material selections. (See paragraph 7.1).

3.1.2 Finish. Exterior of rods shall be plated, passivated, painted or coated in accordance with the modes specification of the airframe under contract for the rod material and area of the airframe as applicable. Interior finish of rods shall comply with MIL-F-7179 or contractually approved company specifications.

3.1.3 Configuration. Tubes shall be symmetrical in cross section with material, wall thickness, and outside dimensions commensurate with the static, environmental and dynamic requirements of the system. This requirement is not to preclude formed clevis ends or local deformation as clearance requirements dictate. The tolerances for the dimensions specified on rod drawings shall be as defined in the applicable tubing specification. Local repair of minor defects is acceptable provided the repaired area is not less than the minimum wall defined in the specification, and provided there shall be no material removal from the swaged sections after swaging. Dimensional increase in wall thickness as required for integral formed clevis ended tubes may have more than one tube diameter and wall required in one part. These may be specified by outer diameter (O.D.) and wall, and will require the appropriate tube specification tolerance to apply, unless specific application dictates other tolerances. Transition from one wall thickness to another will be as detailed by drawing.

MIL-HDBK-1599A

REQUIREMENT 207

3.1.4 Loads, tube and rod assembly strength. Assemblies shall be capable of withstanding limit loads without permanent deformation. Limit loads are maximum or jam loads, the extreme loading the rod assembly can receive prior to failure of components of the functional system other than the rod assembly. Ultimate loads are 1.5 times limit loads. Rod end or tube deformation at ultimate load is acceptable including loss of balls or rollers in antifriction bearings provided the assembly supports the ultimate load. This requirement does not apply to controlled shearout or force limiter assemblies. Mounting adjustable rod assemblies for tension and/or compression fatigue allowable or static testing shall require the adjustable rod end to be engaged only sufficiently to cover the inspection hole. Control rod assemblies designed as torque tubes are not within the scope of this Requirement. Control rod assemblies functioning in push-pull mode shall not be subjected to torsional loads.

3.1.4.1 Assembly static strength and fatigue determination. Tubing cross section size and material, end fitting configuration and material and method of configuring or attaching end fittings shall be such that ultimate tension and compression loads and fatigue life can be achieved without destruction of any component of the assembly. The contractor shall be able to demonstrate that all rods used in critical systems are capable of static loads and fatigue requirements of the system if required by the procuring agency. Determination of criticality of a control system relative to this requirement is the responsibility of the contractor with procuring agency concurrence.

3.1.5 End construction. Aluminum and steel tubes may be swaged directly over an end fitting. Because of the difficulty in effecting a swags engagement between nipple inner diameter (I.D.) and convoluted or knurled end fitting, the swaged material must have adequate ductility and a differential in hardness between mating surfaces. Integrity is further affected by nipple wall thickness. Substantiating data for minimum engagement as well as conformance with static and fatigue strength requirements shall be available for all swage installed attachments as required by the procuring agency. Flashwelding as a means of attaching end fittings to rods shall be used only with steel rods and steel end fittings.

3.2 Design usage of control rods.

3.2.1 End configurations.

3.2.1.1 Fixed ends. All rod assemblies used in primary and secondary controls systems shall have at least one fixed end except vernier coupling as defined in paragraph 3.2.1.2. The term "fixed end" as used herein is defined as attachment of the end fitting in such a manner that rotation or dimensional change will cause failure. The strength of the fixed end relative to preventing rotation shall be considered that of the weakest member of the end assembly relative to forces tending to rotate the rod. In auxiliary controls or in vernier coupler systems where both ends are adjustable, threads on both ends of the rod shall be either right or left hand, not one of each. Rods shall not be used as "turnbuckles" for adjustment of length. Examples of fixed ends are shown in figure 207-1.

3.2.1.2 Vernier coupling effect. Vernier coupling may be required in some systems to precisely position a hydraulic servo relative to cockpit control for example. An NAS 1193 indexable, positive locking device alone will not effect this close adjustment because the fixed end requires the opposite end to be oriented as defined by drawing, making possible adjustment only to the closest 180 degree position. Procuring agency approval is required if both ends of a rod are vernier couplings in primary and secondary controls systems.

MIL-HDBK-1599A

REQUIREMENT 207

Examples of vernier coupler rod assemblies are shown in figure 207-2. Vernier coupling is accomplished with nominal gage length covering the inspection hole or holes and shall be shown to maintain 1.2 thread diameters minimum engagement of both threaded attachments after maximum vernier rotation in either direction.

3.2.1.3 Adjustable ends. Adjustable ends may be threaded directly into tube nipples or may be threaded into an insert which may be affixed by swaging or otherwise, provided the insert can be shown to be attached to the tube as defined for fixed ends per paragraph 3.2.1.1. All adjustable ends shall be threaded per MIL-S-8879 unless otherwise permitted in the contract with the procuring agency. Inspection holes or other means shall be provided for assurance of sufficient thread engagement. Hole location is illustrated in figure 207-3.

3.2.1.4 Bearings. Bearings used with control rods which are integral rod end bearings or mounted in an eye end arrangement shall be capable of misalignment. The exception of these requirements are rods which terminate in an eye or clevis which is attached to a misaligning type bearing. In these cases, the bearing in the rod may be a journal bearing or bushing per requirement 309 or 310, or may be eliminated altogether. Figure 207-4 illustrates these applications.

3.2.2 Rod attachment to equipment.

3.2.2.1 Fixed end. Fixed ends shall be terminated in a hollow or solid shank rod end bearing per requirement 308 or an eye or clevis arrangement with bearings installed in the eye or one or both sides of the clevis per requirement 202. Figure 207-4 illustrates methods of attachment to equipment.

3.2.2.2 Adjustable end. Externally threaded rod end bearings shall be slotted and ends of rods notched for safetied with NAS513 or NA31193. Internally threaded rod end bearings may be notched and external threads of ends of rods slotted for safetied with NAS513 or NAS1193. These conditions are required in primary and secondary control applications. Alternately, control applications may be non-slotted and non-notched and installed with a check nut in auxiliary controls applications.

3.2.2.3 Safetied.

3.2-2-3.1 Fixed end. Safetied of the rod is not applicable.

3.2.2.3.2 Adjustable end. Rod end bearing installation into the rods in primary and secondary controls systems may be safetied by the use of an NAS513 or NA81193 locking device. For cost reasons, NAS1193 should only be used where adjustment requirements exceed the capabilities of NAS513. The nut shall be safety wired to the locking device as shown in figure 207-5.

3.2.2.4 Washer use in cantilever mounting. As illustrated in figure 207-4, when rods are attached to structure, a washer of outside diameter larger than the bearing outside diameters shall be used to prevent loss of the rod by loss of bearing retention.

3.2.2.5 Straightness and requirements. All control rods shall be straight as opposed to angular or "dog-leg" designs. Straightness and angularity requirements of the control rods shall be specified on engineering drawings of the rods.

MIL-HDBK-1599A

REQUIREMENT 207

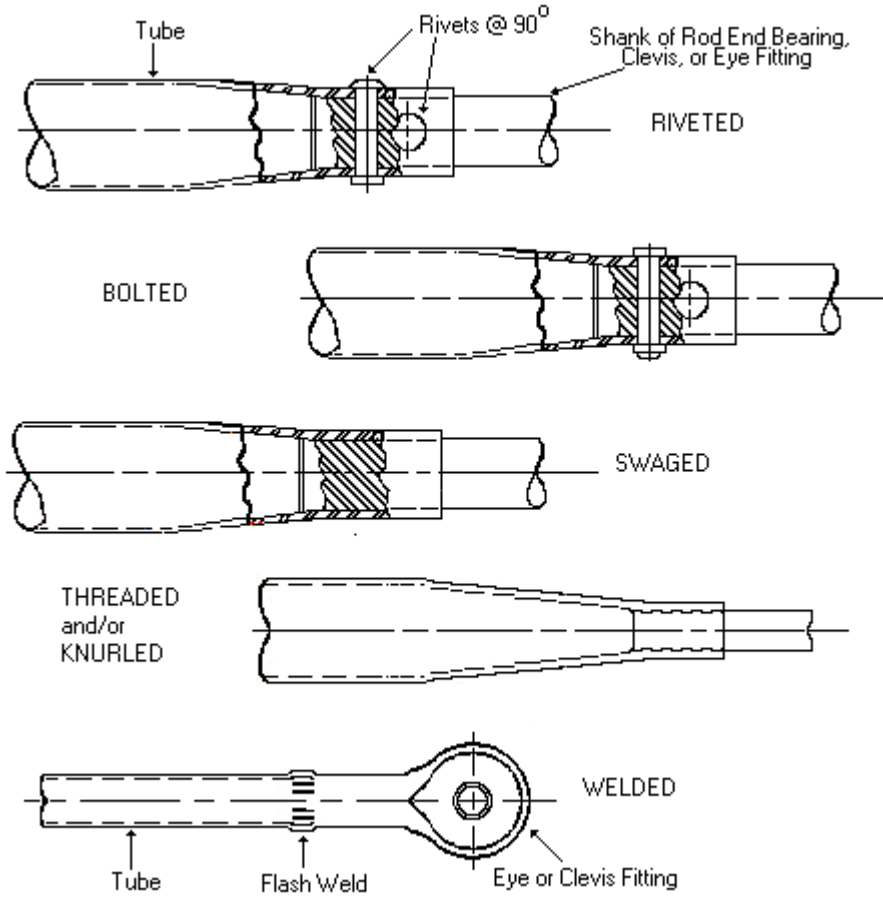


FIGURE 207-1. Fixed ends.

MIL-HDBK-1599A

REQUIREMENT 207

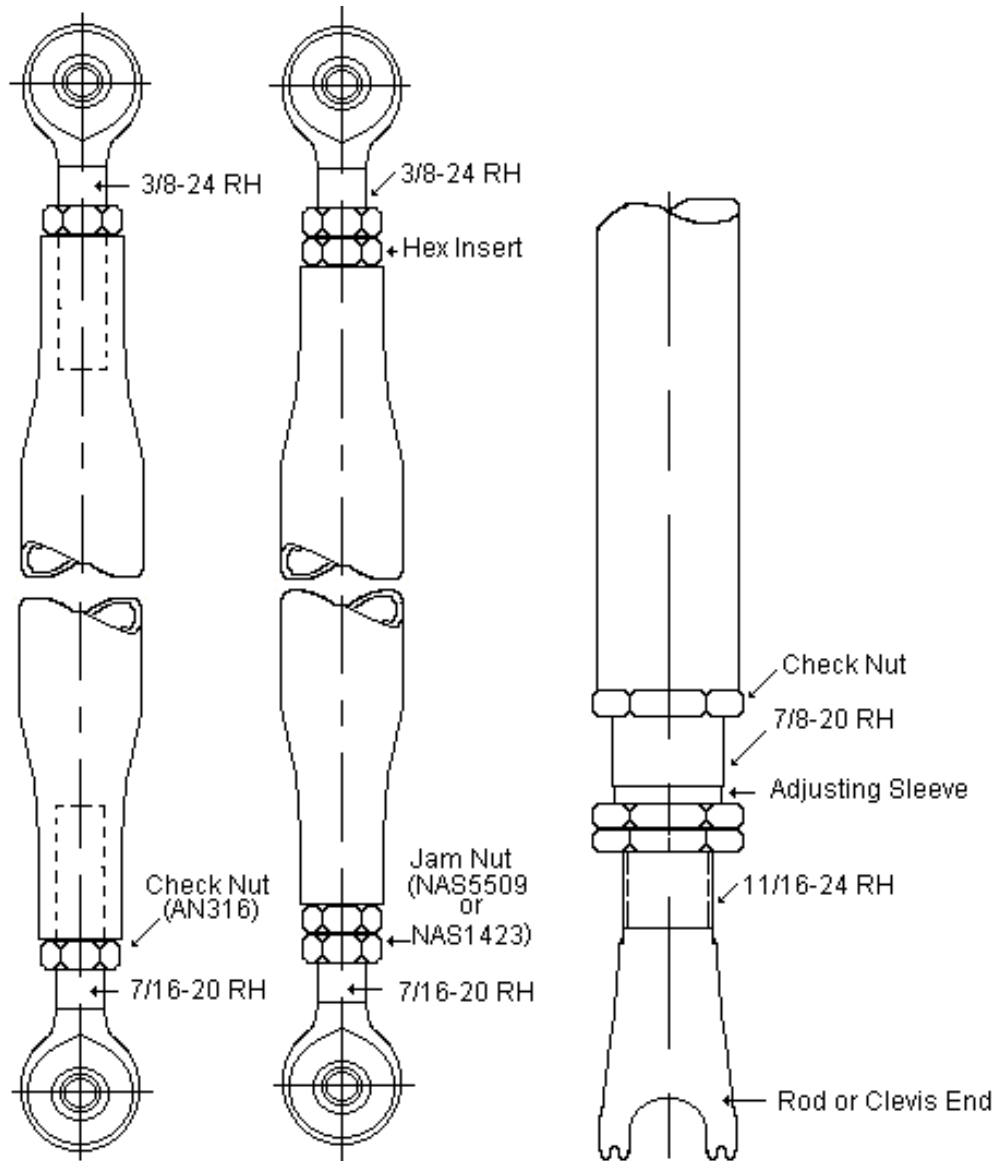


FIGURE 207-2. Vernier couplers, examples.

MIL-HDBK-1599A

REQUIREMENT 207

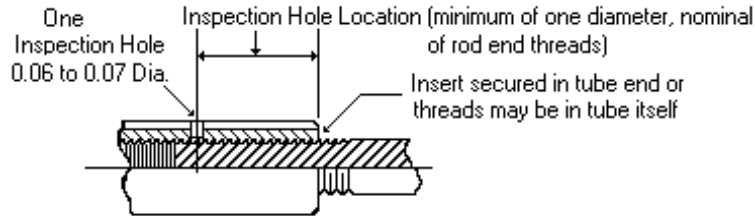


FIGURE 207-3. Inspection hole.

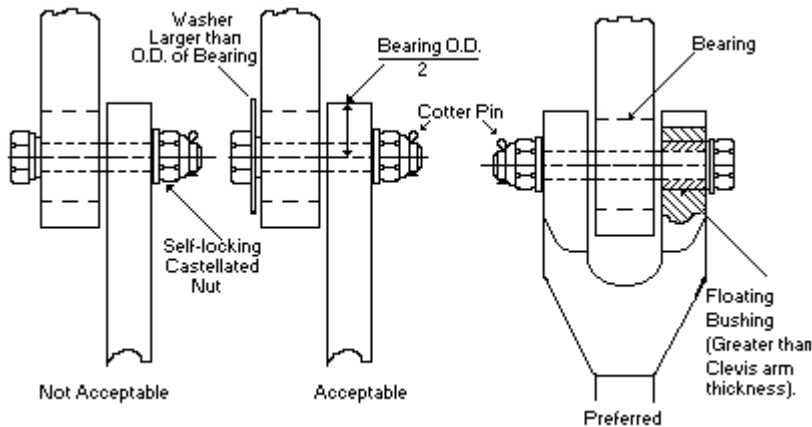


FIGURE 207-4. Methods of attachment.

3.2.2.6 Drain, ventilation requirement. Moisture accumulation may occur tending to partially fill the tubes of rod assemblies not intentionally drained or alternately sealed. Aluminum tubes may be hermetically sealed with a thorough application of a metal filled epoxy sealing/adhesive compound per MMM-A-1754 to the mating threads or surfaces. Drain holes are effective in protecting tubes from bursting and from freezing water, but may reduce fatigue capability by 90 percent. Blind inserts installed with an epoxy sealing compound per MMM-A-1754 may be used to seal the tube end mounting an adjustable rod end as illustrated in figure 207-6. An effective seal requires application of epoxy to the full engagement of both female and male mating parts. Members to be bonded shall be cleaned and free of any trace of oil or grease. Curing of hermetically sealed tubes using an MMM-A-1754 sealing compound shall be at room temperature. Inserts or rod ends so installed may, at prime manufacturer's option, and/or where acceptance testing requires, each be torque tested to verify the bond. Steel tubes other than CRES are difficult to protect from corrosion on I.D. and are difficult to seal. CRES tubes are difficult to seal, but require no corrosion protection. All steel tubes shall have drain holes to protect against collecting water, except that steel tubes that can be demonstrated to be hermetically sealed may be used at discretion of prime contractor.

MIL-HDBK-1599A

REQUIREMENT 207

3.3 Rod and component inspection. Rod assemblies used in primary control systems or other applications considered critical to safety of flight shall be inspected for material and process integrity on a 100 percent basis.

4. Quality assurance provisions.

4.1 Initial testing. Testing shall be accomplished at the contractor's discretion or as required in specific contracts. The contractor is responsible for the integrity of rods for defined system requirements.

5. Design selection, and approved callout. See requirements sections 300 and 600 for approved parts.

6. Tooling. There are no special tooling requirements.

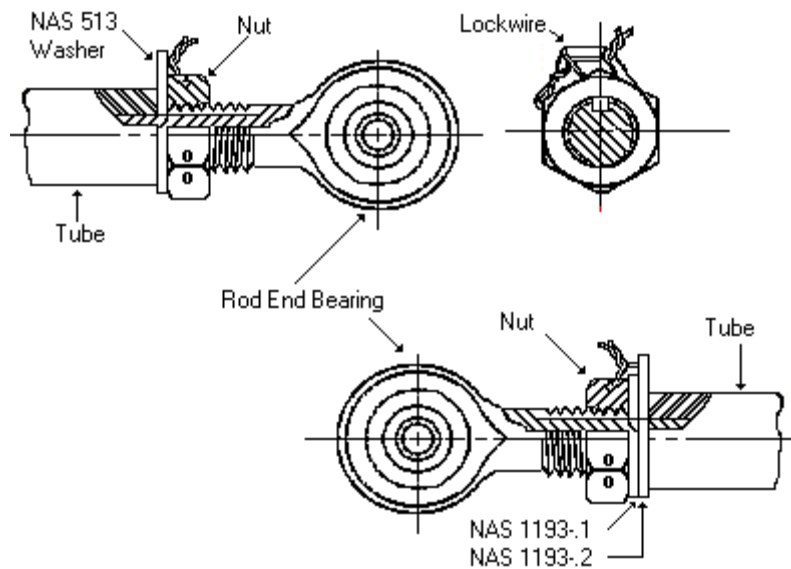


FIGURE 207-5. Adjustable end safetying.

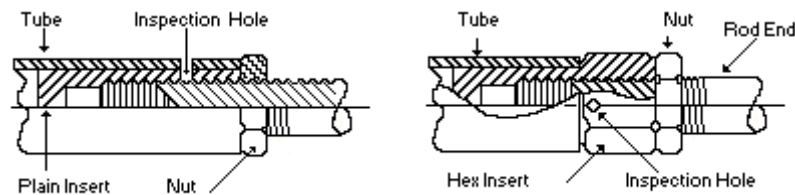


FIGURE 207-6. Blind inserts

MIL-HDBK-1599A

REQUIREMENT 207

7. Intended use or guidance criteria.

7.1 Materials.

7.1.1 Aluminum, steel or titanium tubing may be swaged to an appropriate nipple diameter and tapped to receive a threaded rod end. Titanium tubing work hardens badly with rotary swaging and is more responsive to vail swaging. This process loses greater area in reduction and is therefore a poor candidate for control rod manufacture. The wall increase occurring in the taper is least for titanium, somewhat greater for steel and greatest for aluminum. However, all swagings elongate during swaging, universally having less cross sectional area at the nipple than the body. The further section loss from tapping the nipple requires accuracy in forecasting the appropriate nipple diameter and in the case of aluminum tubes, adds to the desirability of forming threads on the nipple I.D. as compared with cutting threads. Forming threads in steel or titanium tubing is not practical in that these swaged nipples lack ductility for the required thread imprinting. To obtain appropriate section for threading steel or titanium tubes, the unswaged blank may be precontoured or the center section after swaging may be turned off providing the appropriate wall tolerance is maintained.

7.1.2 Steel or titanium tubes for control rod assemblies may be required to support loads in excess of aluminum tubing capability. Abrupt sectional change as well as cut threads are sensitive to fatigue loading. Fatigue capability of these assemblies shall be established and shall be in excess of system requirements.

7.1.3 2024 aluminum tubing is most commonly utilized in manufacturing of control rod assemblies. Some swags reduction is possible in T3 temper, most swaging will require "O" (or annealed) material for swaging with subsequent heat treat to -T42 or -T62 in accordance with MIL-H-6088. The practical limit for reduction in 13 or 0 temper depends on equipment and technique. Reduction in T3 requires subsequent heat treat to T81. Drawing requirement should define acceptable micro-structure or fold depth in the critical area rather than prescribe manufacturing steps.

7.1.4 Many high strength alloys having desirable characteristics in a finished part are undesirable for swage fabrication. The physical characteristic most necessary to the swaging process is ductility. Materials having less than 10 percent elongation may be a poor candidate for swaging. CRES tube manufactured to MIL-T-6845 has excellent ductility, may be specially drawn to 100 KSI tensile strength and is inexpensive. Where loads or environmental considerations preclude aluminum tube, this CRES tube should be evaluated first.

7.1.5 Heat treatment of rods or rod components of alloy steel or heat treatable CRES shall be heat treated in accordance with MIL-H-6875.

7.2 Loading.

7.2.1 An airframe requirement for a control rod assembly presumes assembly column loading in compression as well as tension. Where practicable the load in tension shall be the greatest. Tubes selected to support compression loads in a system are lightest if selected with large diameter and light wall. The limiting factors may be accomodation in the airframe or the largest diameter tubing economically reducible to effect an attachment to the desired rod end, i.e., an aluminum tube 1.37511 O.D. x .03511 wall to be threaded to receive a 3/8-24 rod end will require swaging to a nipple diameter approximately .525 inch.

MIL-HDBK-1599A

REQUIREMENT 207

This reduction of slightly more than 60 percent (1.525/1.375) approaches the practical limit. Reduction in excess of 50 percent will increase costs disproportionately.

7.3 Drawings/Terminology/Practice.

7.3.1 Common terminology applicable to swaged tubes is recommended per figure 207-7.

7.3.2 Swags angle should be limited to close tolerance only if structure or installation dictates.

7.3.3 Effective definition of a swaged tube should define nipple diameter, length, minimum wall allowable swags angle, and concentricity relative to tube body.

7.3.4 Tube cross section area reduction is inherent in the swaging process. The wall increase occurring in the taper coincides with an increase in length. The approximate wall thickness (W<sub>2</sub>) remaining in the nipple and available for attachment may be calculated as follows:

$$W_2 = \left( \frac{D_1}{D_2} \right) (W_1) (.9)$$

Where D<sub>1</sub> = original tube diameter, D<sub>2</sub> = nipple diameter and W<sub>1</sub> = original wall thickness.

7.3.5 Where an integral clevis or threaded nipple is required to have greater material thickness or cross section than the tube body, manufacture should be allowed from larger diameter and heavier wall tubs at supplier option. As illustrated in figure 207-8, the integral formed clevis tube is traced turned to the dimensions shown from 1.375 O.D. x .188 wall stock size. The clevis end is then formed from the original material size to meet the .178/.183 clevis ear thickness requirement. The threaded nipple can be either mandrel swaged, turned and swaged, or swaged and turned to obtain the material thickness at the threaded end(s). When the detail drawing indicates "Tube Body" as shown, tolerances per FED-STD-245 will be maintained.

MIL-HDBK-1599A

REQUIREMENT 207

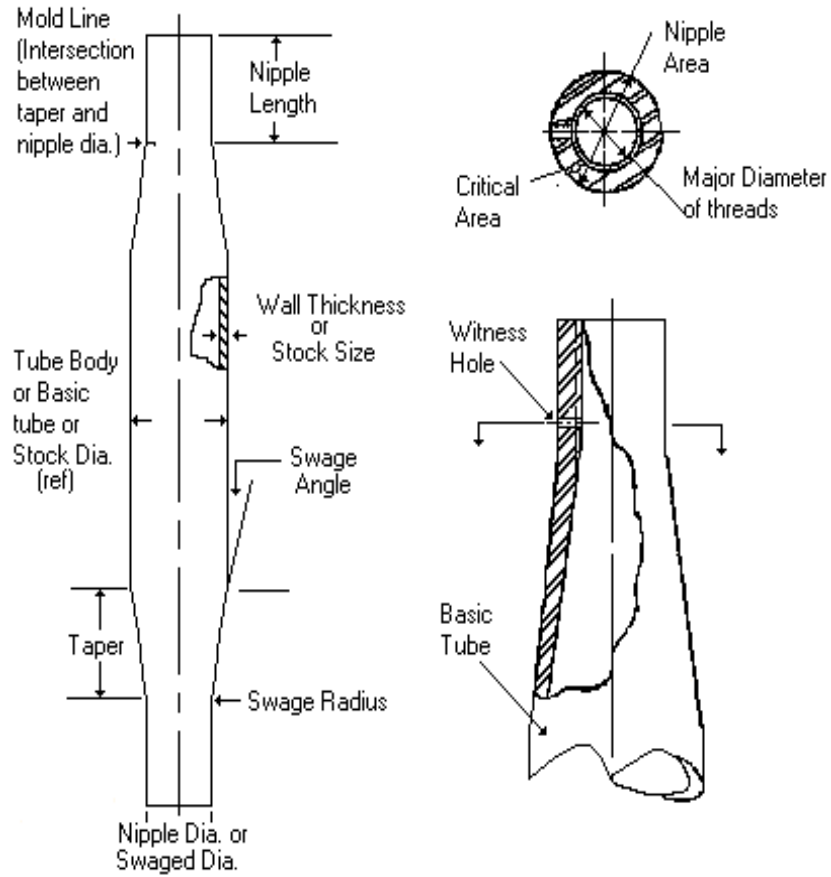


FIGURE 207-7. Common terminology

MIL-HDBK-1599A

REQUIREMENT 207

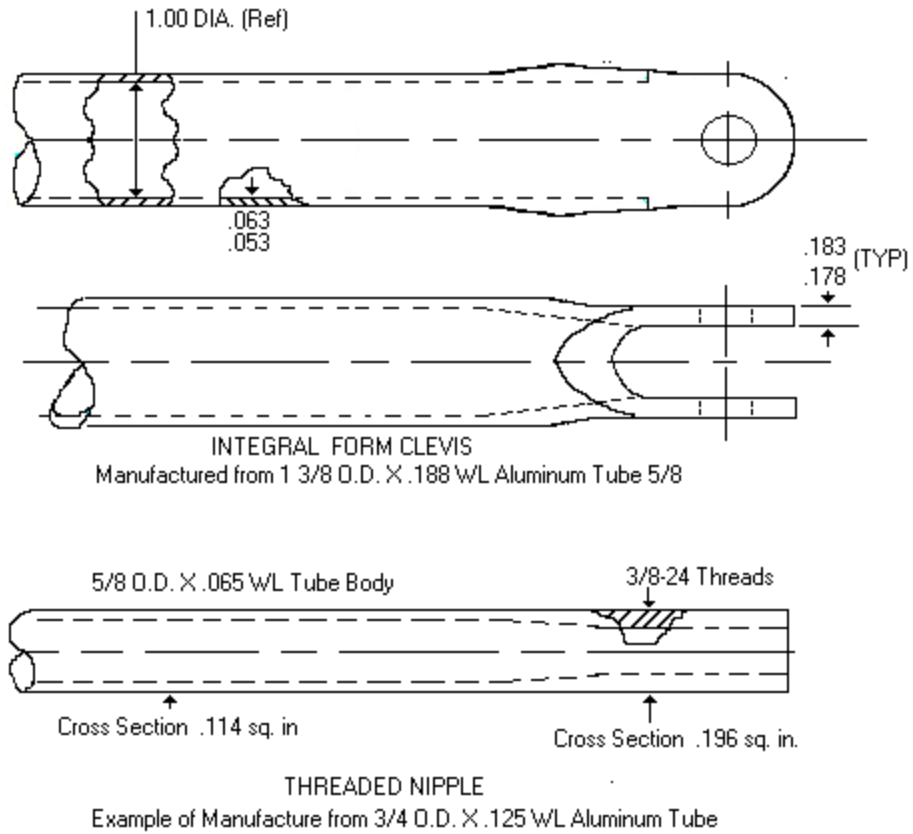


FIGURE 207-8. integral formed clevis and threaded nipple.

MIL-HDBK-1599A

REQUIREMENT 208

PUSH-PULL CONTROLS SYSTEMS DESIGN -REQUIREMENT

1.1 Scope. This requirement establishes engineering criteria and requirements for the selection and application of push-pull controls systems of the flexible inner member types and of the special case of control cables used through rigid or flexible conduits for pull operation only. Approved components, where applicable, are listed in Requirement 601 and 606.

1.2 Classification. Push-pull controls covered by this requirement are of the following types:

- a. Type I, rolling element type
- b. Type II, compound: helical wrapped inner member
- c. Type III, compound: flat wrapped inner member
- d. Type IV, compound: beaded inner member
- e. Type V, single or multiple wire under member
- f. Type VI, pull cable type

2. Applicable Documents.

QQ-C-320	Chromium Plating (Electrodeposited)
QQ-P-416	Plating, Cadmium (Electrodeposited)
MIL-F-7179	Finishes and Coating: Protection of Aerospace Weapons for Systems, Structures, and Parts, General Specification for
MIL-C-7958	Controls, Push-Pull, Flexible and Rigid
MIL-G-23827	Grease, Aircraft and Instrument, Gear and Actuator Screw Grease, Aircraft, General Purpose Wide Temperature Range
MIL-G-81322	Grease, Aircraft, General Purpose Wide Temperature Range
MIL-W-83420	Wire Rope, Flexible, for Aircraft Control
MIL-STD-810	Environmental Test Methods
MIL-STD-1515	Fastener Systems for Aerospace Applications
ASTM-B633	Zinc on Iron and Steel, Electrodeposited Coatings of

3. Construction, design and Usage requirements.

3.1 Construction. The term push-pull control as used herein refers to an assembly generally consisting of a flexible, moving inner member which may consist of, but not be limited to, a solid, stranded, wrapped strand, of beaded construction, enclosed in a rigid or flexible metallic outer member of solid, stranded, or interlocked construction. The control assembly is positioned in the desired configuration and the outer member fastened to the structure. The outer member usually does not move. The inner member is connected to an input and output fitting or device at its ends in such manner that a tension or compression load applied to the inner member will effect a linear motion and force transmission through the control assembly to the attached mechanism at the opposite end.

MIL-HDBK-1599A

REQUIREMENT 208

3.1.1 Types. There are six basic constructions of push-pull controls which may be used for various tasks. For ease of reference, these have been assigned "types" and these designations are intended only for reference and clarity in this document, and are not intended for use in industry catalogs or other similar literature. Combinations of features from the various types may be used in a single control system to compensate for application peculiarities.

3.1.1.1 Type I, rolling element type. The rolling element type basically consists of a flexible inner member and a flexible or rigid outer member, and uses balls or rollers regularly spaced throughout its length, supporting the inner member from line contact with the outer member; thereby providing for rolling friction when the inner member is moved or stroked to do its work (figure 208-1).

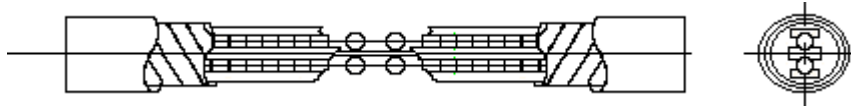


FIGURE 208-1. Typical type I rolling element type.

3.1.1.2 Type II, compound: helical wrapped inner member. The compound, helical wrapped type basically consists of an inner member fabricated of one or more metallic members, usually wrapped with a round metallic strand in a helical form resulting-in a "worm gear" configuration. This is then enclosed in a flexible or rigid outer member. The inner surface of the outer member may or may not be coated with a self-lubricating liner such as Teflon or dry film lubricant (figure 208-2).

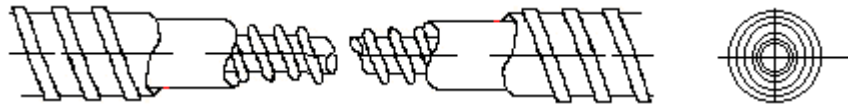


FIGURE 208-2 Typical type II helical wrapped inner member type.

3.1.1.3 Type III, compound: flat wrapped inner member. The compound, flat wrapped helical type, basically consists of an inner member fabricated of one or more metallic members wrapped with a flat metallic band in a helical fashion throughout its length. This element is enclosed in a flexible or rigid outer member. A liner consisting of a material with natural lubricate may or may not be used to improve friction characteristics (figure 208-3).

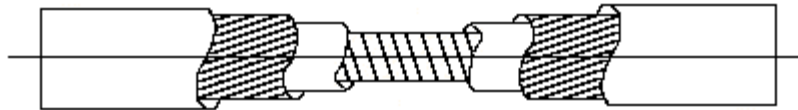


FIGURE 208-3. Typical type III flat wrapped inner member.

3.1.1.4 Type IV, compound: beaded inner member. The compound, beaded inner member type basically consists of a solid or stranded inner member on which are strung beads or shells which may be round, ovalar, or "dog Bone" in shape. The beads or shells are permanently fixed to the inner cable. The beads or shells may be all the same size or alternately sized throughout its length. This element is then enclosed in a flexible or rigid conduit which may be lined with an anti-fruition material or other permanent type of solid lubricant, to aid friction characteristics (figure 208-4).

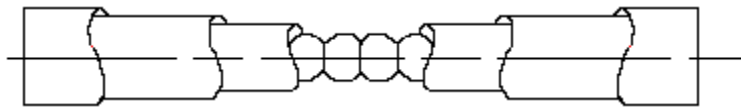


FIGURE 208-4. Typical type IV compound: beaded inner member

3.1.1.5 Type V, single or multiple twisted metal. The single or multiple wire inner member type consists of single or multiple twisted metal wire, or wires, as the inner member. The outer member can be flexible or rigid of metallic, metallic and synthetic, or-synthetic material construction. The inner or outer member may or may not be lubricated (figure 208-5).

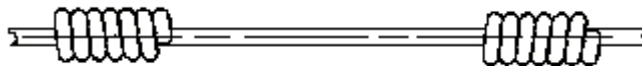


FIGURE 208-5. Typical type V single wire inner member or multiple wire inner member type.

MIL-HDBK-1599A

REQUIREMENT 208

3.1.1.6 Type VI, pull cable type. The pull cable type consists of a standard-wire rope inner member per MIL-W-83420, which may or may not be sheathed with a synthetic material. The outer, member may be rigid or flexible metallic or non-metallic casing. This type is to be used only in pull or tension applications, the return stroke usually being provided by a spring or other device at the output end. Fabrication from standard AN components is preferable but not mandatory (figure 208-6).

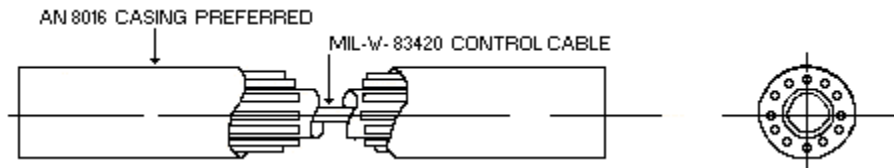


FIGURE 208-6. Typical type VI pull cable type.

3.1.2 Construction options. At the option of the designer, combinations of features of the various types may be used in a single control-system to compensate for peculiarities of design or installation.

3.2 Design and Usage.

3.2.1 Push-Pull controls design requirements.

3.2.1.1 Materials and environmental factors.

3.2.1.1.1 Materials. Push-pull controls shall be fabricated or materials consistent with the requirements of the specific acquisition document. Generally, the assemblies shall be manufactured from steel, aluminum, or steel and aluminum, as determined by the design requirements. Non-metallic materials used for casing, encasing the conduit, seals or other components shall be compatible with the environment and other requirements of the specific acquisition document. These materials shall be of such composition as to not require age control. The contracting agency shall specifically define the environment to which the push-pull controls will be subjected including salt fog exposure, high and low temperature extremes, altitude, vibration, sand and dust, shock and acceleration as defined in MIL-STD-810.

3.2.1.1.2 Finishes and corrosion protection. Finishes, platings and coatings shall be in agreement with the specific aircraft model specification or equivalent as defined in MIL-F-7179. Steel components which are exposed to the environment shall be corrosion resistant steel, chrome, or cadmium plated alloy steel. Cadmium plating shall be in accordance with QQ-P-416, type !I, class 2. Zinc plating shall be in accordance with ASTM B633. Chrome plating shall be in accordance with QQ-C-320. Protective finishes applied to aluminum components shall be in accordance with the specific acquisition documents.

3.2.1.1.3 Lubrication and sealing. Whenever possible, push-pull controls shall be designed in such a manner as to not require lubrication or be lubricated for life. These controls may utilize the lubricant and method of lubrication selected by the control manufacturer unless otherwise specified by the acquisition agency or contractor. Control assemblies which, with the approval of the acquisition agency or contractor, require lubrication in service

MIL-HDBK-1599A

REQUIREMENT 208

shall utilize MIL-G-23827, MIL-G-81322, or equivalent grease. Lubricated controls shall provide the means to entrap lubricant and prevent entry of contaminants commensurate with design requirements.

3.2.1.1.4 Encasement of Outer Member. Outer member may be encased with nonmetallic material as desired by the contractor or acquisition agency for the purpose of aesthetics, isolation from electrical equipment, protection from moisture or foreign material entry, or abrasion resistance.

3.2.1.2 End fittings.

3.2.1.2.1 Fittings. Types I, II, III, and IV control assemblies shall be furnished with telescopic type fittings attached to each end of the assembly. These fittings may be threaded, clevis, eyes, knobs, handles or other configurations applicable to the specific needs of the control installation. Wherever possible, end fittings should conform to industry standards. End fittings for types I, II, III, and IV push-pull controls shall be capable of sustaining loads as specified by the design documents or the acquisition agency. Telescoping units on types II, III, and IV units shall be capable of conical misalignment of 4 degrees minimum from theoretical center throughout full design travel. Type I controls shall be applied to the application in such a manner that misalignment of end fittings to the connecting devices is suitably accommodated. The cable assembly portion of type VI controls shall conform to Requirement 206 for control cable assemblies. Type V controls may be connected to equipment by a clip which slides onto the wire. The clip shall be capable of the maximum load which will be applied to operate the system without sliding off the wire.

3.2.1.2.2 Outer member mounting provisions. The area of the control which will be attached to bracketry or a bulkhead shall be suitably threaded to accept jam nuts and lock washers on both sides of the bracket or bulkhead. The length of mounting thread shall be sufficient to provide adjustment of the end fitting position to the extent required by the acquisition agency. Push-pull controls may be mounted in flanged devices which will attach to brackets or bulkheads by means of screws, nuts and lock washers or bolts and lock washers. Clamp type fittings which engage into an undercut area of the mounting sleeve are permissible provided the mount is capable of sustaining the maximum load which will be applied to the system.

3.2.1.2.3 Knobs and handles. Knobs and handles which are used in conjunction with push-pull controls shall be of sufficient size, shape, and strength to allow manual operation of the control at maximum load. Knobs and handles shall be removable and replaceable without distortion or destruction of any element for purposes of replacement installation and maintenance.

3.2.2 Usage.

3.2.2.1 System restrictions. The application of push-pull controls in primary controls, secondary controls, or auxiliary systems shall be at the discretion of the acquisition agency based upon qualification by test or similarity to other qualified or certified applications. Type V controls are limited to auxiliary, noncritical application.

3.2.2.2 Usage factors

3.2.2.2.1 Attachment to equipment. End fittings may be attached by rod end bearing or clevis and eye with bolts or screws and nuts per the requirements of MIL-STD-1515. Ends shall be threaded through a bell crank or similar component and secured with a nut per MIL-STD-1515 and a locking device per MIL-STD-1515 or MIL-HDBK-1599.

MIL-HDBK-1599A

REQUIREMENT 208

3.2.2.2.2 Friction. Resistance to motion caused by friction is a significant concern when designing a push-pull control into a system. System efficiency, output versus input, is affected by the number of bends, bend radii and overall length of the various types of push-pull controls. The anti-friction characteristics of the various types of push-pull controls should be considered when designing for a particular system. Utilization of a specific type control shall be determined by the functional requirements of the acquisition agency's specifications.

3.2.2.2.3 Backlash. Backlash in a particular control assembly is an accumulation of various assembly construction factors. These lost motion factors include mechanical clearance, necessary to minimize friction effect, manufacturing tolerances and elastic properties of the materials used in the control. Backlash is the total accumulation of these factors and this condition must be considered when designing a system. Backlash varies with the various types in generally increasing order from type I through type VI.

3.2.2.2.4 Loading. Push-pull controls vary in load transmission capability, a consideration which must be reviewed when designing a system. Various factors affect the input force required to accomplish a given load transmission through a push-pull control stroke. These include overall length, bend radii, number of bends, friction, and output load. Review of these factors during the design stage will allow the design activity to choose the type control best suited to a given system. Where possible, push-pull controls should be utilized with the predominant load transmission being accomplished while the control is in tension. Mounting brackets or other structure to which the controls will be attached must be of sufficient rigidity and strength to react to all the forces transmitted by the control.

3.2.2.2.5 Travel. The travel of a push-pull control is the linear motion transmitted from the input to the output. Control travel or stroke must include the actual output stroke required plus the lost motion of the control assembly. Control travel should not significantly exceed the system requirement because of major effects on end fittings and control performance.

3.2.2.2.6 Overall length. There is no restriction on overall length of push-pull controls. Generally, friction buildup will limit the lengths of types II through VI. Type I controls are recommended for long runs.

3.2.2.2.7 Safetying. Where practical, push-pull control assemblies shall be so constructed that external safety wiring or clips are not required to maintain integrity. Safetying of nuts, bolts, etc., at attaching points to structure or functioning equipment shall be as required by the overall control system and Requirement 204.

3.2.2.3 Mounting. Both ends of the conduit of types I, II, III and IV push-pull controls shall be mounted to structure of sufficient strength and rigidity to prevent deflection of the conduit axially or radially when the control is operated at maximum load. The control assembly shall be clamped to a structure of sufficient strength and rigidity within 6 inches of each tangency point of curves and shall be further clamped to structure at least each two feet of straight length. Clamps shall be so located that deflection of the control during operation will not cause the assembly to contact the structure of functional equipment or move into the envelope of motion of moving equipment. Clamps shall be sized such that they do not squeeze or distort the control conduit. Clamps shall be of the same type used for electrical conduits or plumbing tubing on the airframe design. Type V shall be connected to the structure at the handle end and may or may not be connected at the other end. Type VI shall be clamped as necessary. Note that type I controls require special considerations relative to bend planes and installation sequence

MIL-HDBK-1599A

REQUIREMENT 208

3.2.2.4 Routing. In addition to the avoidance of equipment and structure noted in 3.2.2.3, routing shall be such that radii of bends are at least as large as recommended by the control manufacturers, but not less than 12 times the outer member diameter and in no case less than 3 inches. Even these minimum radii should be avoided-near the ends of the system to minimize friction buildup. Bends in type I controls may require large radii.

3.2.2.5 Type selection data. The application requirements of load, friction, backlash, type of attachments, routing, weight, cost, etc., determine the type of push-pull control necessary for proper and reliable functioning of the system. Trade off between types may be necessary for optimization of the system. Table 208-I has been provided herein as a guide to initial consideration for design selection. Table 208-I presents several guidelines as to controls applicability. It is not intended to limit application.

4. Quality Assurance.

4.1 Control testing. Testing shall be accomplished at the contractor's discretion or as required in the specific acquisition document. The contractor is responsible for the integrity of the push-pull controls for defined system requirements. MIL-C-7958 shall be considered in developing test requirements.

TABLE 208-1. Design selection data.

SUITABLE USAGE														
	Efficiency	Backlash	Friction	Load Capability	Weight	Cost	Ruggedness	Precision	Bend Capability	Comments	Primary	Secondary	Auxiliary	Ground Equipment
TYPE I	H	L	L	M	M	M/H	M	H	M	Good for long runs	P	P	A	A
TYPE II	M	L	M	M	M	M/H	M	M/H	M		A	P	A	A
TYPE III	M	M/L	M	H	M/H	M	H	M	M		A	A	P	A
TYPE IV	M	M/L	M	M	M/H	M	M/H	M	M	Good compressive capability	A	P	A	A
TYPE V	L	L	M/L	L	L	L	M	L	H		N	P	A	A
TYPE VI	L	L	H	L	L	L	L	L	H	Tension Applications Only	A	A	A	A

H = High	P = Preferred
M = Moderate	A = Acceptable
L = Low	N = Not Acceptable (should not be used)

MIL-HDBK-1599A

REQUIREMENT 210

## UNIVERSAL JOINTS AND COUPLINGS

1. Scope. This requirement establishes criteria and guidance information relative to the selection and use of universal Joints and couplings for torsional control driveshafts in aerospace vehicle applications. Criteria includes type descriptions and typical applications, and performance.

2. Applicable Documents.

MIL-U-3963	Universal Joint, Anti-Friction Bearings
MIL-J-6193	Joints, Universal, Plain, Light and Heavy Duty
MS 20270	Joint-Universal, Plain, Light Duty
MS 20271	Joint-Universal, Plain, Heavy Duty
MS 24312	Joint-Universal, Anti-Friction Bearing, Round Hub

3. Application. Universal joints and couplings may be used in primary and secondary flight controls and other control systems.

3.1 Universal joint usage.

3.1.1 Classifications of universal Joints. Two general classifications of universal joints are:

- a. Cardan (Hooke's) Joint)
- b. Constant velocity joint

3.1.1.1 Cardan (Hooke's Joint). The Cardan (Hooke's Joint) is available in two types:

- a. Plain bearing
- b. Anti-Friction bearing

3.2 Coupling usage. Couplings are used for the transmitting of torque between shafts or associated equipment.

3.2.1 Rigid couplings. Rigid couplings are used when no angular axial misalignment occurs.

3.2.2 Flexible couplings. Flexible couplings are used for small angular misalignment of less than three degrees, although for intermittent low speed applications, the misalignment may be increased.

MIL-HDBK-1599A

REQUIREMENT 210

4. Design requirements.

4.1 Design and construction. It is the intention of this requirement to define universal Joints and couplings of such a design that will operate a long period of years with a minimum of servicing. The design and construction shall be the lightest and most compact consistent with the following requirements in their order of importance.

- a. Reliability
- b. Maintainability
- c. Efficiency

4.2 Materials. Materials shall be selected in accordance with Requirement 104.

4.3 Corrosion protection. Corrosion protection shall be provided in accordance with Requirement 105.

5. Performance. Universal Joints and coupling performance is dependent upon the subjected application or usage.

5.1 Universal Joint Performance.

5.1.1 Plain bearing universal joints. Plain bearing universal Joints are Used where limiting speeds up to 2000 rpm are attained.

5.1.2 Anti-friction bearing universal-joints. Anti-friction bearing universal Joints are more expensive and weigh more than plain bearing types. These Joints shall only be used where high torques or speeds must be transmitted.




5.1.3 Constant velocity joints. Constant velocity joints are larger, High more, and cost more than Cardan (Hooke's Joints) type Joints; therefore their use shall be limited.


5.1.4 Vibration. The use of a single universal joint is not preferred where the operating speed is high or where a large amount of power is to be transmitted due to non-uniform angular velocity causing undesirable vibrations. A double universal Joint assembly or to joints connected by a short shaft shall be used to eliminate the vibration.

5.1.5 Misalignment. The universal joint shall be used if the misalignment exceeds two degrees and does not exceed 30 degrees.

5.1.6 Angle and shaft speed. The suggested maximum universal joint angle for corresponding shaft speeds is listed in table 210-1.

Table 210-1. Angle and shaft speed.

Shaft Speed (RPM)	MAXIMUM OPERATING ANGLE (Degrees)		
	Plain Bearing Type	Plain Bearing Type (Oil Bath)	Antifriction Bearing Type
Less than 175	30 	----	-----
175-1000	15 	15	15
1000-2000	15 	15	15
2000-3000			12.5
3000-4000			8.5
4000-5000			6.5
Over 5000			5

 For Intermittent Power Operation or Hand Drive

5.1.7 Torque limitation

5.1.7.1 Plain bearing universal Joint. Typical torque limitation for plain bearing universal joints are listed in table 210-II.

5.1.7.2 Anti-friction-universal-Joint. Typical torque limitation for anti-friction universal joints are listed in table 210-III.

5.2 Coupling-performance.

5.2.1 Rigid couplings. Typical rigid couplings used for torque transmission are listed in table 210-IV.

5.2.2 Flexible couplings. Typical flexible couplings recommended for used in aircraft applications are described in table 210-V.

MIL-HDBK-1599A

REQUIREMENT 210

Table 210-II. Typical torque limitation, plain bearing U-Joint.

Type	Joint Size	Ultimate Static Torque (In-Lbs)	Hand Driven Low RPM (Max. In-Lbs)	Torque Load (Max.)	Horse Power Transmitted (Max.)
Plain Bearing (Light Duty) MS 20270	0.7500	175	-	26	0.07
	0.5000	250	130	28	0.11
	0.6250	500	250	75	0.21
	0.7500	1000	500	150	0.42
	0.8750	1750	875	262	0.73
	1.0000	2500	1250	375	1.05
	1.2500	5000	2500	750	2.08
	1.5000	7500	3750	7725	3.15

Plain Bearing (Heavy Duty) MS 20271	0.3750	200	-	30	0.08
	0.5000	600	300	90	0.25
	0.6250	1080	540	162	0.45
	0.7500	1900	1100	285	0.8
	0.8750	3000	1750	450	1.26
	1.0000	4700	2500	705	1.99
	1.2500	9500	5000	1425	4
	1.5000	14500	7500	2175	6.04

Table 210-III. Typical torque limitations, anti-friction bearing U-joint.

Type	Joint Size	Ultimate Static Torque (In-Lbs.)	500 RPM 100,000 Rev. (In.-Lbs)	1500 RPM 100,000 Rev. (In.-Lbs)
Ball Bearing Joints (MS 24312)	¾	1500	500	167
	1	3000	1000	333
	1/1/04	7500	1500	500
	1/1/02	11000	2000	667
	1/3/04	15000	2500	833
	2	20000	3000	1000

MIL-HDBK-1599A

REQUIREMENT 210

Table 210-IV. Rigid couplings.

METHODS FOR TORQUE TRANSMISSION

TYPES	APPLICATIONS
A. Rigid couplings, bolted sleeves, flanges, or keyed bolts	Transfer of rotational, low torque no angular or linear displacement
B. Splines	Transfer of rotational, low torque small linear displacement, no angular displacement.
C. Serrations	Transfer of rotational, high torque; with no angular displacement with or without small linear displacement.

Table 210-V. Flexible couplings.

Type	Shaft Diameter (in)	Power Transmission Capabilities	Continuous RPM (Max)	Deflection	Remarks
A. Flexible Member Element	1/2 and larger	Approximately equal to shaft capacity	30,000	+/- 1 degree per flexible element	Available in wide range of types and sizes for most applications
B. Miniature Flexible Element	up to 5/8	60 in-lbs	30,000	+/- 1 degree maximum	for use in servo-mechanism and other small devices
C. Bellows type	3/4 and larger	140 HP	10,000	+/- 1 degree maximum	-----
D. Gear type	1/2 and larger	Approximately equal to shaft	20,000	+/- 2 degree maximum	Not suitable for heavy shock loads

MIL-HDBK-1599A

REQUIREMENT 301

AIRFRAME BEARINGS, BALL, ANTI-FRICTION

1. Scope

1.1 This requirement establishes engineering criteria and requirements for the selection and application of rolling element anti-friction ball bearings for aerospace systems.

1.2 Classification. Anti-friction ball bearings covered by this requirement are of the following classes:

- a. Extra light duty
- b. Intermediate duty
- c. Heavy duty
- d. Double row
- e. Double row, self-aligning
- f. Extra wide
- g. Single row
- h. Single row, self-aligning

2. Applicable Documents.

MIL-B-7949	Bearing, Ball, Airframe, Anti-Friction
MS21428	Bearing, Ball, Airframe, Anti-Friction, Extra Light Duty Precision
MS27640	Bearing, Ball, Airframe, Anti-Friction, Heavy Duty
MS27641	Bearing, Ball, Airframe, Anti-Friction, Heavy Duty, Intermediate Duty
MS27642	Bearing, Ball, Airframe, Extra Light Duty
MS27643	Bearing, Ball, Airframe, Anti-Friction, Self-Aligning, Double Row, Heavy Duty
MS27644	Bearing, Ball, Airframe, Anti-Friction, Double Row, Heavy Duty
MS27645	Bearing, Ball, Airframe, Anti-Friction, Self-Aligning, Light and Heavy Duty
MS27646	Bearing, Ball, Airframe, Anti-Friction, Extra Light Duty
MS27647	Bearing, Ball, Airframe, Anti-Friction, Extra Wide, Double Row, Intermediate Duty
MS27648	Bearing, Ball, Airframe, Anti-Friction, Externally Self-Aligning, Extra Light Duty
MS27649	Bearing, Ball, Airframe, Anti-Friction, Intermediate Duty

3. General. Anti-friction ball bearings are used throughout airframe systems in many different types of applications and environmental conditions. For selection and usage guidelines, see requirement 201. For shaft, housing, and installation, see requirement 202.

4. Requirement.

4.1 Qualification. Anti-friction ball bearings defined under this requirement shall be products which are qualified for listing on the applicable qualified products list of MIL-B-7949.

MIL-HDBK-1599A

REQUIREMENT 301

4.2 Design and construction. These bearings conform to the requirements of MIL-B-7949, MS21428, MS27640, MS27641, MS27642, MS27643, MS27644, MS27645, MS27646, MS27647, MS27648, and MS27649.

4.3 Performance.

4.3.1 Radial limit load rating. These bearings have a minimum limit load rating as specified on the applicable MS.

4.3.2 Radial fracture load. The minimum static fracture load is not less than 1 1/2 times the radial limit load value specified on the applicable MS.

4.3.3 Axial limit load rating. These bearings have a minimum limit load rating as specified on the applicable MS.

4.3.4 Axial fracture load. The minimum axial fracture load is not less than 1 1/2 times the axial limit load values specified on the applicable MS.

4.3.5 Radial dynamic load rating.

4.3.5.1 These bearings have a radial dynamic load rating, at 250°F, as specified on the applicable MS for an average life of 10,000 cycles when oscillated through an arc of 90°F.

4.3.5.2 These bearings have a radial dynamic load rating, at 350°F, of not less than 80 percent of the value specified on the applicable MS for an average life of 10,000 cycles when oscillated through an arc of 90°F.

MIL-HDBK-1599A

REQUIREMENT 302

AIRFRAME BEARINGS, ANTI-FRICTION ROLLER

1. Scope. This requirement establishes engineering criteria and requirements for the selection and application of self-aligning, anti-friction sealed, airframe roller bearings for aerospace systems.

2. Applicable Documents.

MIL-B-8914	Bearings, Roller, Self-Aligning Airframe, Anti-Friction
MS28912	Bearings, Roller, Self-Aligning, Single Row, Airframe, Double Row, Airframe, Anti-Friction, Sealed, Type I
MS28913	Bearings, Roller, Self-Aligning, Anti-Friction, Sealed, Type II
MS28914	Bearings, Roller, Self-Aligning, Double Row, Wide Inner Ring, Type III Airframe, Anti-Friction, Sealed,
MS28915	Bearings, Roller, Self-Aligning, Double Row, Torque Tube, Type IV Airframe, Anti-Friction, Sealed,
MS21431	Bearings, Roller, Self-Aligning, Single Row, Anti-Friction, Sealed, -65°F - 350°F, Type I

3. General. Typical airframe roller bearings utilize a compliment of rollers separating an outer ring and an inner ring. The outer ring is usually mounted in the housing and the inner ring on the shaft. Other elements of these bearings may be rolling element separators, shields or seals, and seal retainers.

3.1 Usage. Guidelines on selection are contained in requirement 201.

4. Design requirements. Design and construction of these bearings shall conform to the requirements of MIL-B-8914, MS28912, MS28913, MS28914, MS28915, and MS21431.

5. Performance requirements. Engineering criteria on friction, torque, temperature capabilities, and rotational and alignment capabilities are contained in requirement 201.

6. Installation and retention. Guidelines on installation and retention are contained in requirement 201 and requirement 202.

MIL-HDBK-1599A

REQUIREMENT 303

ANTI-FRICTION BEARINGS, NEEDLES, INCLUDING TRACK ROLLERS

1. Scope. This requirement establishes engineering criteria and requirements for the selection and application of needle bearings and track rollers for aerospace systems.

2. Applicable Documents.

MS17131	Bearing, Roller, Needle, Thin Outer Race, Without Inner Race, Open End and Closed End
MS17136	Race, Bearing, Inner, Carbon Steel, Needle Roller Bearings
MS21432	Bearing, Roller, Needle, Track Roller, Integral Stud, Type 7, Anti-Friction, Inch
MS24461	Bearing, Roller, Needle, Single Row, Heavy Duty, Type 1, Anti-Friction, inch
MS24462	Bearing, Roller, Needle, Single Row, Thin Shell, Type 2, Anti-Friction
MS24463	Bearing, Roller, Needle, Single Row, Heavy Duty, Self Aligning, Type 3, Anti-Friction, Inch
MS24464	Bearing, Roller, Needle, Double Row, Heavy Duty, Self Aligning, Type 4, Anti-Friction, Inch
MS24465	Bearing, Roller, Needle, Single Row, Heavy Duty, Track Roller, Type 5, Anti-Friction, Inch
MS24466	Bearing, Roller, Needle, Double Row, Heavy Duty, Track Roller, Type 6, Anti-Friction, Inch
MS51961	Bearing, Roller, Needle: Thick Outer Ring with Rollers and Cage
MS51962	Ring, Bearing Inner: For Needle Roller Bearings with Thick Outer Ring

3. Requirements.

3.1 General. Needle bearings and track rollers are used throughout airframe applications in a variety of different modes of operation. Their application and mounting is somewhat more critical than other anti-friction bearings. For detailed instructions on the application and mounting of needle bearings and track rollers, refer to requirement 201, MIL-HDBK-1599, covering bearing usage.

MIL-HDBK-1599A

REQUIREMENT 304

### MINIATURE ANTI-FRICTION BEARINGS

Miniature anti-friction bearings are not ordinarily used as airframe bearings. Consequently, no parts are listed for use in this requirement. Unless specifically prohibited by Requirement 201, the usage of this type of bearing as an airframe bearing shall be governed by the application of the procedures described in Requirements 101 and 102.

A miniature ball bearing is defined as one having an outside diameter less than 0.375 inch or 9 mm, but in recent years they have been treated as instrument bearings rather than as a separate category (see Requirement 201). Uses of this type bearing as an airframe bearing in an aerospace vehicle is limited.

For further information regarding instrument/miniature ball bearings, see MIL-B-81793, Bearings, Ball, Precision, For Instruments and Rotating Components.

MIL-HDBK-1599A

REQUIREMENT 305

#### FLUID FILM BEARING

Fluid film bearings are not ordinarily used as airframe bearings. Consequently, no parts are listed for use in this requirement. Unless specifically prohibited by Requirement 201, the usage of this type bearing as an airframe bearing shall be governed by the application of the procedures described in Requirements 101 and 102.

MIL-HDBK-1599A

REQUIREMENT 306

AIRFRAME BEARINGS, SPHERICAL, ALL-METAL

1. Scope

1.1 This requirement defines the characteristics and application of metal-to-metal plain spherical bearings and lists the approved bearings in this category.

1.2 Application. All-metal plain spherical bearings are used in applications where the ratio of static load to dynamic load is high. That is, bearing loads are relatively low during movement between the ball and the outer ring and relatively high when there is no motion between the ball and the outer ring. They are also used in areas where the service imposes impact loading and in areas where the bearings is lightly loaded. All-metal plain spherical bearings are used in applications where environmental conditions and/or application requirements exceed the capabilities of lined spherical bearings, (see requirement 307). Where all-metal plain spherical bearings are used, provisions for lubrication are normally required to prevent, or minimize, fretting and galling.

1.3 Classification. All-metal plain spherical bearings are classed according to the materials used, the lubrication features, and the retention features.

1.3.1 Materials. The available all-metal plain spherical bearing material combinations are defined in the referenced military standards and include bearings with a steel ball and steel outer ring, with a steel ball and aluminum bronze outer ring, and with a beryllium copper ball and stainless steel outer ring.

1.3.2 Lubrication features. All-metal plain spherical bearings are available with two types of lubrication features. The standard type (no type code included in part number) incorporates a lubrication groove in the ball bore with three lubrication channels from the ball bore to the ball OD. This type also includes lubrication grooves in the outer ring OD and ID, with three lubrication channels from the outer ring ID to the outer ring OD. The standard lubrication feature is available for all material combinations. The beryllium copper ball and stainless steel outer ring combination has an optional lubrications feature. When the letter "R" is included in the part number, the lubrication groove and channels are eliminated from the ball component and are present in the outer ring only. ("R" means "outer ring only.")

1.3.3 Retention-features. Two styles of all-metal plain spherical bearings are available as defined on the referenced military standards. These standards include a style which incorporates a retention groove machined into the outer ring faces for staking of the bearings into a chamfered housing and a style with a chamfered outer ring OD to be used where the retention device is included in, or is a part of the housing. Requirement 202 of this military standard describes specific bearing retention techniques in detail.

MIL-HDBK-1599A

REQUIREMENT 306

2. Applicable Documents.

MIL-B-8976	Bearings, Plain, Self-Aligning, All-Metal
MIL-G-81322	Grease, Aircraft, General Purpose, Wide Temperature Range (paragraph 4.6.2)
MIL-B-81936/1	Bearings, Plain, Self-Aligning, -65°F to +350°F
MIL-B-81936/2	Bearings, Plain, Self-Aligning, BeCu Ball, Cres Race, -65°F to +350°F
MS21154	Bearings, Plain, Self-Aligning, Grooved Outer Ring, -65°F to +350°F
MS21155	Bearings, Plain, Self-Aligning, -65°F to +350°F
ANSI B46.1	Surface Texture, Surface Roughness, Waviness and Lay

3. General. An all-metal plain spherical bearing is a machine element allowing a load to be transmitted from one structural member into another. At the same time, the bearing permits relative movement between the two structural members while preventing separation and minimizing mechanical damage or wear. A plain spherical bearing permits rotational movement about its bore axis and misalignment rotation about the two remaining axes. Where the ball ID and OD are lubricated, and the ball is not positively locked to the pin, rotational motion (oscillation) will occur between the pin OD and the ball ID and misaligning motion will occur between the ball OD and outer ring ID.

4. Design requirements.

4.1 Qualification. Bearings specified in paragraph 2.2 shall be used in design and shall be procured from qualified manufacturers as required by procurement specifications.

4.2 Materials. The materials are listed on the applicable standard,

4.3 Design. Bearing design conforms to that specified on the applicable military standard or drawing.

4.4 Dimensions and tolerances. Dimensions and tolerances are specified on the applicable military standard or drawing. Dimensions not shown shall be at the option of the manufacturer.

4.5 Surface texture. Surface texture is in accordance with the applicable military standard or drawing. Surface texture shall be measured in accordance with ANSI B46.1.

4.6 Lubrication and temperature.

4.6.1 All plain spherical bearings require some form of lubrication to reduce friction within the bearing and to minimize metallurgical bonding (welding) between the bearing components. The bearings described by the referenced military standards are designed to facilitate grease lubrication and, as such, will be suitable for operation within the temperature range from -65°F (-54°C) to +350°F (+177°C).

4.6.2 For preservation purposes, the bearings are shipped lubricated in accordance with the applicable military standard or drawing. Where no lubrication is specified, the bearing will be shipped packed in MIL-G-81322. The date (month, year) of lubrication shall be marked on each bearing package.

4.7 Hardness. The component hardness is as specified on the applicable military standard or drawing.

5. Performance.

MIL-HDBK-1599A

REQUIREMENT 306

5.1 Static load ratings. Static loads are loads which are imposed on plain spherical bearing while there is no relative motion between the bearing components

5.1.1 Static radial limit load. The static radial limit load is the maximum load which can be applied to the bearing and housing in direction A, (see figure 1) with a limited amount of permanent set as defined in the applicable specification.

5.1.2 Static radial ultimate load. The static radial ultimate load is 1.5 times the static radial limit load. After application of the static radial ultimate load, there may be significant permanent deformation of the bearing components. There shall not, however, be any cracked or broken components.

5.1.3 Static axial limit load. The static axial limit load is the maximum load that can be applied to the bearing and housing in direction B or C (see figure 1) with a limited amount of permanent set as defined in the applicable specification.

5.1.4 Static axial ultimate load. The static axial ultimate load is 1.5 times the static axial limit load. After application of the static axial ultimate load, there may be significant permanent deformation of the bearing components. There shall not, however, be any cracked or broken components.

5.2 Dynamic (oscillating) load ratings. Dynamic loads are loads which are imposed on a plain, spherical bearing while there is relative motion between the bearing components. Dynamic load ratings as specified on the military standards are qualification loads used to develop comparative data for bearing performance, These bearings can be operated dynamically at loads up to the specified limit loads; however, the amount of wear developed will be affected by the magnitude of the load and the oscillation angle. When operated dynamically, all-metal bearings should periodically experience reverse loading so that the lubricant is redistributed to the load zone to minimize wear.

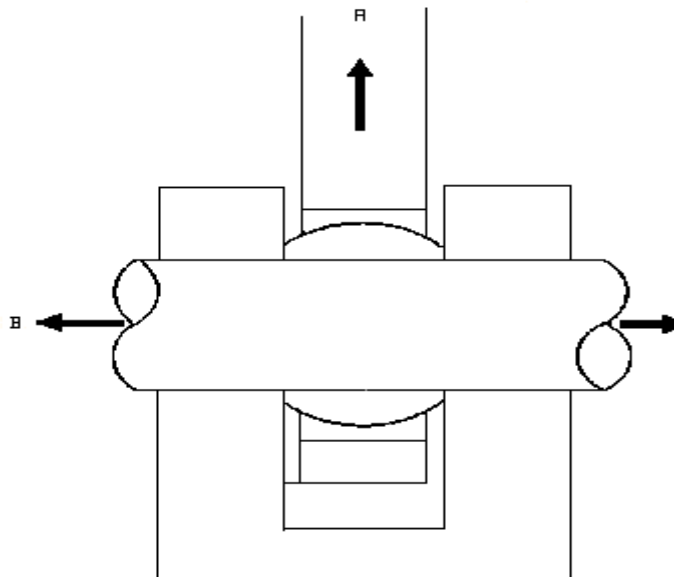


FIGURE 306-1. Static load ratings.

MIL-HDBK-1599A

REQUIREMENT 307

AIRFRAME BEARINGS, SPHERICAL, LINED

1. Scope

1.1 This requirement defines the characteristics and application of lined, plain, spherical bearings and lists the approved bearings in this category.

1.2 Application. Lined, plain, spherical bearings are used in applications where it is necessary for the bearing to function without requiring relubrication. The liner in the bearing provides a permanent source of low friction lubricant and the bearings do not require relubrication throughout their service life. The application of lined, plain, spherical bearings shall be limited to areas where the ambient temperature does not exceed the range from -65°F to +325°F. In addition, lined, plain, spherical bearings are not recommended in applications where the service imposes severe impact loading or continuous long-term high speed full rotation.

1.3 Classification. Lined, plain, spherical bearings are classed according to the race width. MS14101 and MS14104 define narrow series lined, plain, spherical bearings MS14102 and MS14103 define wide series lined, plain, spherical bearings.

1.3.1 Materials. Lined, plain, spherical bearings as defined by the applicable MS Standards are supplied with an outer ring fabricated from 17-4 PH stainless steel per AMS 5643. The standard (no identifier in part number) lined, plain, spherical bearings as defined by the MS Standards include a ball fabricated from 440C stainless steel. Where improved corrosion resistance is required, the MS bearings can be supplied with a PH 13-8Mo stainless steel ball. This option is obtained by including the code letter "C" in the part number. These bearings include self-lubricating liners to reduce friction within the bearing and do not require relubrication through their service life. As this self-lubricating liner is expended, an increase in radial play will be noticed.

1.3.2 Type. Two types of lined, plain, spherical bearings are available. Type I lined, plain, spherical bearings include a fabric or filament-wound liner of uniform thickness which is bonded to the ID of the outer ring. Type II lined, plain, spherical bearings incorporate a molded composition liner.

1.3.3 Retention features. Two styles of lined, plain, spherical bearings are available as defined on the applicable military standards. These standards include a style which incorporates a retention groove machined into the outer ring faces for staking of the bearing into a chamfered housing, and a style with a chamfered outer ring OD to be used where the retention device is included in, or is part of the housing. Requirement 202 of this military standard describes specific bearing retention techniques in detail.

2. Applicable Documents.

MIL-B-81819	Bearings, Plain, Self-Lubricating, Self-Lubricating, High-Speed Oscillation
MIL-B-81820	Bearings, Plain, Self-Aligning, Self-Aligning, Low-Speed Oscillation
MS14101	Bearing, Plain, Self-Lubricating, Self-Aligning, Low-Speed, Narrow, Grooved Outer Ring, -65°F to +325°F

MIL-HDBK-1599A

REQUIREMENT 307

MS14102	Bearing, Plain, Self-Lubricating, Self-Aligning, Low-Speed, Wide, Chamfered Outer Ring, - 65°F to +325°F
MS14103	Bearing, Plain, Self-Lubricating, Self-Aligning, Low-Speed, Wide, Grooved Outer Ring, - 65°F to +325°F
MS14104	Bearing, Plain, Self-Lubricating, Self-Aligning, Low-Speed, Narrow, Chamfered Outer Ring, - 65°F to +325°F
AMS 5643	Steel Bearings, Forging, Tubing and Rings, Corrosion Resistant 16Cr-4.ONi-0.30 (Cb-Ta) - 4.0Cu (paragraph 1.3.1)
ANSI B46.1	Surface Texture, Surface Roughness, Waviness and Lay

3. **General.** A plain, spherical bearing is a machine element allowing a load to be transmitted from one structural member into another. At the same time, the bearing permits relative movement between the two structural members while preventing separation and minimizing mechanical damage or wear. A plain, spherical bearing permits rotational movement about its bore axis and misalignment rotation about the two remaining axes.

4. **Design requirements.**

4.1 **Qualifications.** MS14101 through MS14104 bearings shall be used in design and shall be procured from qualified manufacturers as required by procurement specifications.

4.2 **Materials.** The material is as listed on the applicable standard.

4.3 **Design.** Bearing design conforms to that specified on the applicable military standard or drawing.

4.4 **Dimensions and tolerances.** Dimensions and tolerances are as specified on the applicable military standard or drawing. Dimensions not shown shall be at the option of the manufacturer.

4.5 **Surface texture.** Surface texture is in accordance with the applicable military standards or drawing. Surface texture shall be measured in accordance with ANSI B46-1.

4.6 **Lubrication and temperatures.** Lined, plain, spherical bearings are permanently lubricated by a low-friction liner included between the outer race and ball. These bearings do not require relubrication. They are suitable for operation in the temperature range from -65°F to +325°F.

4.7 **Hardness.** The component hardness is as specified on the applicable military standard or drawing.

5. **Performance.**

5.1 **Static load ratings.** Static loads are loads which are imposed on a plain, spherical bearing while there is no relative motion between the bearing components.

5.1.1 **Static radial limit load.** The static radial limit load is the maximum load which can be applied to the bearing and housing in direction A (see requirement 306, figure 306-1) with a limited amount of permanent set as defined in the applicable specification.

MIL-HDBK-1599A

REQUIREMENT 307

5.1.2 Static radial ultimate load. The static radial ultimate load is 1.5 times the static radial limit load. After application of the static radial ultimate load, there may be significant, permanent deformation of the bearing components. There shall not, however, be any cracked or broken components.

5.1.3 Static axial limit load. The static axial limit load is the maximum load that can be applied to the bearing and housing in direction B or C (see requirement 306, figure 306-1), with a limited amount of permanent set as defined in the applicable specification.

5.1.4 Static axial ultimate load. The static axial ultimate load is 1.5 times the static axial limit load. After application of this load, there may be significant permanent deformation of the bearing components. There shall not, however, be any cracked or broken components.

5.2 Dynamic (oscillating) load ratings. The dynamic load is a load applied to the bearing (generally a radial load) while the bearing is functioning. During dynamic loading, the self-lubricating liner in the bearing will sustain wear as it provides lubrication.

5.2.1 MIL-B-81820 and MS14101, MS14102, MS14103, and MS14104 define oscillating loads (or dynamic loads) for those airframe bearings shown on the MS sheets. These dynamic loads are defined for test purposes only. Standard dynamic wear tests are included in MIL-B-81820 which define the test conditions for these qualification tests. The bearings can, however, be operated at other loads than those defined as "oscillating load" and up to the "radial limit load". Under the standard test conditions in MIL-B-81820, with no contamination, the bearing must not develop more than .0045 liner wear after 25,000 cycles. Higher loads will result in more wear as will the presence of contamination.

5.2.2 MIL-B-81819 includes four (4) sets of wear test conditions for typical helicopter rotor head applications. These test requirements are not for qualification purposes, but are to be used to compare the performance of potential liner systems.

5.2.2.1 Because of the wide variety of operating conditions, it has not been possible to standardize helicopter rotor head bearings. The four (4) sets of test conditions in MIL-B-81819 have been selected to blanket the total range of expected applications and one (1) of those conditions should closely approximate the actual requirements for any helicopter. Ideally, when a designer begins defining his rotor head applications, he can select that test condition which most closely approximates his bearing size and operational requirements. Data for that test condition from several bearing manufacturers will be available at the Naval Air Development Center. Upon request, he will receive and can select the best candidate liners for his requirements. Additional qualification testing may be required to his specific conditions.

5.2.2.2 As with the airframe bearings, increased loads and the presence of contaminating environments will reduce the wear life of helicopter rotor head bearings.

MIL-HDBK-1599A

REQUIREMENT 308

ROD ENDS

1. Scope

1.1 This requirement defines plain, spherical, self-lubricating rod ends, roller bearing rod ends, and ball bearing rod ends for aerospace systems.

1.2 Classifications. Rod ends shall be classified as follows:

- a. Type I - Plain spherical self-lubricating rod ends
- b. Type II - Roller bearing rod ends
- c. Type III - Ball bearing rod ends
- d. Class I - Externally threaded
- e. Class 2 - Internally threaded
- f. Class 3 - Solid shank
- g. Class 4 - Hollow shank
- h. Composition A - Fabric bearing liner of uniform thickness which is bonded to the inside diameter of the outer race
- i. Composition B - Molded composition liner system

2. Applicable Documents.

MIL-B-6039	Bearing, Double Row, Ball, Sealed Rod End, Anti-Friction, Self-Aligning
MIL-B-8952	Bearing, Roller, Rod End, Anti-Friction, Self-Aligning
MIL-B-81935	Bearing, Plain, Rod End, Self-Aligning, Self-Lubricating
M81935/1	Bearing, Plain, Rod End, Self-Aligning, Self-Lubricating, Externally Threaded, -65°F to +325°F
M81935/2	Bearing, Plain, Rod End, Self-Aligning, Self-Lubricating, Internally Threaded, -65°F to +325°F
MS14103	Bearings, Plain, Self-Lubricating, Self-Aligning, Low Speed, Wide, Grooved Outer Ring, -65°F to +325°F
MS21150	Bearing, Double Row, Ball, Rod End, Precision, Solid Shank, Self-Aligning, Anti-Friction, Airframe, Type I, -65°F to +350°F
MS21151	Bearing, Double Row, Ball, Rod End, Precision, External Thread, Self-Aligning, Anti-Friction, Airframe, -65°F to +350°F
MS21152	Bearing, Double Row, Ball, Rod End, Precision, Hollow Shank, Self-Aligning, Anti-Friction, Airframe, Type III, -65°F to +350°F
MS21153	Bearing, Ball, Rod End, Precision, Internal Thread, Self-Aligning, Anti-Friction, Airframe, - Type IV, -65°F to +350°F
MS21220	Bearing, Roller, Rod End, Internal Thread, Self-Aligning, Anti-Friction, Airframe, Heavy Duty, Type II, -67°F to +350°F, Sealed
MS21221	Bearing, Roller, Rod End, External Thread, Self-Aligning, Anti-Friction, Airframe, Heavy Duty, Type 1, -67°F to +350°F, Sealed
MS21223	Bearing, Roller, Rod End, External Thread, Self-Aligning, Anti-Friction, Airframe, Heavy Duty, Type II, -67°F to +350°F, Sealed
MS21429	Bearing, Roller, Rod End, External Thread, Self-Aligning, Anti-Friction, Airframe, Heavy Duty, Type I, -67°F to +350°F, Sealed

MIL-HDBK-1599A

REQUIREMENT 308

3. Intended use. Types I, II, and III rod ends are for use in aerospace systems in many difference applications and environments.

4. Requirements.

4.1 Qualifications.

4.1.1 Type I, class 1 and class 2, composition A and composition B rod ends are products that conform to the requirements of MIL-B-81935.

4.1.2 Type II, class 1 and class 2 rod ends are products that conform to the requirements of MIL-B-8952.

4.1.3 Type III, class 1, class 2, class 3, and class 4 rod ends are products that conform to the requirements of MIL-B-6039.

4.2 Design and construction.

4.2.1 Type I, class 1 and class 2, composition A and composition B rod ends are products that conform to the requirements of MIL-B-81935, M81935/1, M81935/2, and MS14103.

4.2.2 Type II, class 1 and class 2 rod ends are products that conform to the requirements of MIL-B-8952, MS21220, MS21221, MS21223, and MS21429.

4.2.3 Type III, class 1, class 2, class 3, and class 4 rod ends are products that conform to the requirements of MIL-B-6039, MS21150, MS21151, MS21152, and MS21153.

4.3 Performance.

4.3.1 Load ratings for type I, class 1 and class 2, composition A and composition B rod ends

4.3.1.1 Static radial ultimate load. Static radial ultimate load is defined in MIL-B-81935. After application of this load, there may be significant permanent deformation of the rod end and bearing cartridge components. However, application of the ultimate loads specified on M81935/1 and M81935/2 shall not result in cracked or broken components.

4.3.1.2 Axial static proof load. There shall be no push out of the bearing cartridge when the axial proof loads specified on M81935/1 and M81935/2 are applied.

4.3.1.3 Fatigue load. Rod ends covered by MIL-B-81935 are capable of withstanding a minimum of 50,000 cycles of the fatigue loads specified on M81935/1 and M81935/2 when applied at a rate not exceeding 2800 cycles per minute.

4.3.2 Load ratings for type II, class 1 and class 2 rod ends

4.3.2.1 Limit load rating. Limit load rating is defined as the maximum static load that can be applied to the bearing without seriously affecting the predicted life. These loads are specified on MS21220, MS21221, MS21223, and MS21429.

MIL-HDBK-1599A

REQUIREMENT 308

4.3.2.2 Ultimate load retaining. This is defined as the load which can be applied and held for 3 minutes without structural failure of the bearing. The ultimate load rating is calculated as the limit load rating, as specified on MS21220, MS21221, MS21223, and MS21429, multiplied by a factor of 1.5. In application, **brinelling** will occur on the race surface if subjected to a load equal to the ultimate load rating. The bearing will still be operative even though the races may be brinelled, but the bearing should be replaced.

4.3.2.3 Dynamic load rating. The dynamic load rating is defined on the basis of a unidirectional load that will result in an average bearing life ( $L_{50}$ ) of 10,000 cycles at 90° oscillation before evidence of contact fatigue occurs. The angle of oscillation is defined as 180° of angular travel within an included arc of 90°. These loads are specified on MS21220, MS21221, MS21223, and MS21429.

4.3.3 Load ratings for type III, class 1, class 2, class 1, and class 4

4.3.3.1 Radial limit load ratings. The bearings have a minimum radial limit load rating as specified on MS21150, MS21151, MS21152, and MS21153.

4.3.3.2 Radial static fracture load. The minimum radial static fracture load is not less than 1 1/2 times the radial limit load specified on MS21150, MS21151, MS21152, and MS21153.

4.3.3.3 Axial limit load rating. The bearings have a minimum axial limit load rating as specified on MS21150, MS21151, MS21152, and MS21153.

4.3.3.4 Axial fracture load. The minimum axial fracture load is not less than 1 1/2 times the axial limit load specified on MS21150, MS21151, MS21152, and MS21153.

4.3.3.5 Radial dynamic load rating at 250°F. The bearings have a radial dynamic load rating at 250°F as specified on MS21150, MS21151, MS21152, and MS21153 for an average life of 15,000 cycles when oscillated through an arc of 90°.

4.3.3.6 Radial dynamic load rating at 350°F. The bearings have a radial dynamic load at 350°F of not less than 80 percent of the value specified on MS21150, MS21151, MS21152, and MS21153 for an average life of 10,000 cycles when oscillated through an arc of 90°.

MIL-HDBK-1599A

REQUIREMENT 309

BUSHINGS

1. SCOPE

1.1 Scope. This requirement establishes engineering criteria and requirements for the selection and application of bushings for aerospace systems. These design requirements are peculiar to these bushings and are to be used as a supplement to requirements specified in Requirement 201. This requirement also identifies the presently approved bushings for aerospace applications.

1.2 Classification. Bushings covered by this requirement are of the following classes:

- Class A - Plain, ream type
- Class B - Flanged, ream type
- Class C - Plain, non-ream type
- Class D - Flanged, non-ream type

2. APPLICABLE DOCUMENTS

2.1 Government documents.

2.1.1 Specifications, standards, and handbooks. The following specifications, standards, and handbooks form a part of this document to the extent specified herein. Unless otherwise specified, the issue of these documents are those listed in the issue of the Department of Defense Index of Specifications and standards (DODISS) and supplement thereto, cited in the solicitation (see 3.2)

STANDARDS

MILITARY

MS 14237 Bushing, Sleeve, Plain, Press Fit, Ream Type

MS 14238 Bushing, Sleeve, Flanged, Press Fit, Ream Type

(Unless otherwise indicated, copies of federal and military specifications, standards, and handbooks are available from the Naval Publications and Forms Center, (ATTN: NPODS), 5801 Tabor Avenue, Philadelphia, PA 19120-5099.)

2.1.2 Other Government documents, drawings, and publications. The following other Government documents, drawings, and publications form a part of this documents to the extent specified herein.

MIL-HDBK-1599A

REQUIREMENT 309

Unless otherwise specified, the issues are those cited in the solicitation.

DODISS - Department of Defense Index of Specifications and Standards.

(Copies of the DODISS are available on a yearly subscription basis either from the Government Printing Office hard copy, or microfiche copies are available from the director, Navy publications and Printing Service Office, 700 Robbins Avenue, Philadelphia, PA 19111-5093.)

2.2 Non-Government publications. The following documents form a part of this document to the extent specified herein. Unless otherwise specified, the issues of the documents which are DoD adopted are those listed in the issue of the DODISS cited in the solicitation. Unless otherwise specified, the issues of documents not listed in the DODISS are the issues of the documents cited in the solicitation (see 6.2).

AMERICAN NATIONAL STANDARDS INSTITUTE (ANSI)

ANSI B46.1 Surface Texture (surface Roughness, Waviness and lay.)

(Copies of the above publication may be obtained from the American National Standards Institute, ATTN: Sales Dept., 1430 Broadway, New York, NY 10018-3363.)

## STANDARDS

### INDUSTRY

NAS 75 Bushing-Plain, Press Fit, Steel

NAS 76 Bushing-Plain, Press Fit, Copper & Bronze

NAS 77 Bushing-Flanged, Press Fit, Steel, Bronze & Copper

(Copies of the above publication may be obtained from the American National Standards Institute, ATTN: Sales Dept., 1430 Broadway, New York, NY 10018-3363.)

2.3 Order of precedence. In the event of a conflict between the text of this document and the references cited herein, (except for related associated detail specifications, specification sheets, or MS standards), the text of this document takes precedence. Nothing in this document, however, supersedes applicable laws and regulations unless a specific exemption has been obtained.

## 3. DEFINITIONS

3.1 Bushings (general). Bushings have a simple cylindrical construction that may or may not be flanged. They may be used without lubrication provisions in static joints or low speed dynamic joints to protect structure and provide an economical, easily replaced element. Similar to plain spherical bearings, bushings allow a load to be transmitted from one structural member into and permit rotational movement along the axis of the bushing between the two parts. They also provide bolt clamp-up shoulders, reduce wear, and make friction and wear more predictable. Bushings, however, do not have misalignment capability.

MIL-HDBK-1599A

REQUIREMENT 309

3.1.1 Ream type bushings. MS 14237 and MS 14238 bushings have a reduced inside diameter that requires reaming after assembly. This is necessary because of reduction and possible distortion of the inside diameter when the bushing is installed with an interference fit to the housing or to accommodate line reaming of multiple bushings. Depending on the application, reaming may be accomplished after installation to obtain close tolerance of bushing I.D.

3.1.2 Non-ream type bushings. NAS 75, NAS 76, and NAS 77 are intended for installed on with a lighter press fit (push fit). They have an inside diameter that is satisfactory for use with standard close tolerance bolts where ream tolerances are desired but without subsequent machining. Non-ferrous NAS 76 and NAS 77 bushings may be reamed if required, however, to accommodate line reaming of multiple bushings.

#### 4. GENERAL REQUIREMENTS

4.1 Approved parts. Bushings specified in section 2 shall be used in design from qualified manufacturers as required by procurement specifications. Bushings other than those listed above must be approved by the acquisition activity for each application.

4.2 Materials and finish. The materials and finish of the bushings shall be in accordance with the applicable military standard or drawing.

4.3 Design. Pushing design conforms to that specified on the applicable military standard or drawing.

4.4 Dimensions and tolerances. Dimensions and tolerances are as specified on the applicable military standard or drawing and shall apply to the after plating condition. Other dimensions not shown shall be at the option of the manufacturer.

4.5 Surface texture. Surface texture shall be in accordance with the applicable military standard or drawing and shall be measured according to ANSI B46.1 requirements.

4.6 Lubrication. The bushings covered by this requirement are intended to be used without lubrication provisions. Other special metallic bushings, however, may be solid film lubricated or grease lubricated (when lube grooves and holes are provided in the design).

#### 5. DETAIL REQUIREMENTS

5.1 Installation and retention. Bushings are designed to be installed and retained using a press/interference fit. Adhesive can be used to aid in the retention, but care shall be taken to avoid installations which rely on adhesive as the sole means of retaining the bearing in an oversized hole. Adhesive brittle failure may occur in such cases. Housing fits and resulting clearance shall be in accordance with the installation drawing.

MIL-HDBK-1599A

REQUIREMENT 309

6. NOTES

6.1 Intended use. This requirement is intended to establish engineering criteria and requirements for the selection and application of bushings for aerospace systems. These design requirements are peculiar to these bushings and are to be used as a supplement to requirements specified in Requirement 201. This requirement also identifies the presently approved bushings for aerospace applications.

6.2 Issue of DODISS. When this requirement is used in acquisition, that issue of the DODISS to be applicable to this solicitation must be cited in this solicitation (see 2.1.1 and 2.2).

MIL-HDBK-1599A

REQUIREMENT 310

BEARINGS, SLEEVE, METALLIC, SELF-LUBRICATING

1. SCOPE

1.1 Scope. This requirement establishes engineering criteria and requirements for the selection of self-lubricating metallic sleeve bearings for aerospace systems. These design requirements are peculiar to these types of bearings and are to be used as a supplement to design requirements specified in Requirement 201. This requirement also identifies the presently approved lined sleeve bearings for aerospace applications.

2. APPLICABLE DOCUMENTS

2.1 Government documents

2.1.1 Specifications, standards, and handbooks. The following specifications, standards, and handbooks form a part of this document to the extent specified herein. Unless otherwise specified, the issue of these documents are those listed in the issue of the Department of Defense Index of Specifications and standards (DODISS) and supplement thereto, cited in the solicitation (see 6.2)

SPECIFICATIONS

MILITARY

MIL-B-81934	Bearings, Sleeve, Plain and Flanged, Self-Lubricating
MIL-B-81934/1	Bearing, Sleeve, Flanged, Self-Lubricating, -65° to +325°F
MIL-B-81934/2	Bearing, Sleeve, Flanged, Self-Lubricating, -65° to +325°F

(Unless otherwise indicated, copies of federal and military specifications, standards, and handbooks are available from the Naval Publications and Forms Center, (ATTN: NPODS), 5801 Tabor Avenue, Philadelphia, PA 19120-5099.)

2.1.2 Other Government documents, drawings, and publications. The following other Government documents, drawings, and publications form a part of this document to the extent specified herein. Unless otherwise specified, the issues are those cited in the solicitation.

DODISS - Department of Defense Index of Specifications and Standards.

(Copies of the DODISS are available on a yearly subscription basis either from the Government Printing office hard copy, or microfiche copies are available from the director, Navy publications and Printing Service Office, 700 Robins Avenue, Philadelphia, PA 19111-5093.)

MIL-HDBK-1599A

REQUIREMENT 310

2.2 Non-Government publications. The following documents form a part of this document to the extent specified herein. Unless otherwise specified, the issues of the documents which are DoD adopted are those listed in the issue of the DODISS cited in the solicitation. Unless otherwise specified, the issues of documents not listed in the DODISS are the issues of the documents cited in the solicitation (see 6.2)

AMERICAN NATIONAL STANDARDS INSTITUTE (ANSI)

ANSI B46.1 Surface Texture (surface Roughness, waviness and lay.)

(Copies of the above publication may be obtained from the American National Standards Institute, ATTN: Sales Dept., 1430 Broadway, New York, NY 10018-3363.)

2.3 Order of precedence. In the event of a conflict between the text of this document and the references cited herein, (except for related associated detail specifications, specification sheets, or MS standards), the text of this document takes precedence. Nothing in this document, however, supersedes applicable laws and regulations unless a specific exemption has been obtained.

3. DEFINITIONS

3.1 Sleeve bearings (general). Sleeve bearings have a simple cylindrical construction that may or may not be flanged. The self-lubricating lining is bonded to the inside diameter of the bearing and the external surface of the flange (when used). Similar to plain spherical bearings, sleeve bearings allow a load to be transmitted from one structural member into another and permit rotational movement along the axis of the bearing between the two parts. These bearings, however, do not have misalignment capability.

4. GENERAL REQUIREMENTS

4.1 Approved parts. MIL-B-81934/1 and MIL-B-81934/2 bearings shall be used in design and procured from qualified manufacturers as listed on the applicable qualified products list for MIL-B-81934. These bearings are approved for use in new design, modification, or repair of aerospace vehicles or ground support equipment. Sleeve bearings other than those listed above must be approved by the acquisition activity for each application.

4.2 Materials and finish. The materials and finish of the bearings shall be in accordance with the applicable military standard or drawing.

4.3 Design. Bearing design conforms to that specified on the applicable military standard or drawing. Special design applications shall not exceed a length to bore ratio of 5:1.

4.4 Dimensions and tolerances. Dimensions and tolerances are as specified on the applicable military standard or drawing. Dimensions not shown shall be at the option of the manufacturer.

4.5 Surface texture. Surface texture shall be in accordance with the applicable military standard or drawing and shall be measured according to ANSI B46.1 requirements.

4.6 Lubrication. Lined sleeve bearings are not permitted to be initial grease or oil lubricated by the manufacturer since the liner is self-lubricating. They should also be kept free of any relubrication. The liners are sacrificial and the normal wear ratio can be accelerated by liquid contaminants such as oils and greases.

MIL-HDBK-1599A

REQUIREMENT 310

4.7 Temperature range. These sleeve bearings shall not be used in applications which exceed the temperature limits of -65°F and +325°F as listed in the military standard or drawing.

5. DETAIL REQUIREMENTS

5.1 Performance.

5.1.1 Static radial limit load. The static radial limit load is the maximum radial load applied to the bearing and housing which may result in a maximum permanent set as defined in the applicable military standard or drawing. For static limit load capacity calculations, see the calculations for lined sleeve bearings in Requirement 201.

5.1.2 Dynamic (oscillating) radial load rating. The dynamic radial load is the load which is applied to the bearing while there is oscillatory motion occurring between the bearing and mating pin. The oscillation angle, number of cycles and corresponding maximum wear allowed is defined in the applicable military specification. For dynamic load capacity calculations, see the lined sleeve bearing calculations in Requirement 201.

6. NOTES

6.1 Intended use. This requirement is intended to establish engineering criteria and requirements for the selection of self-lubricating metallic sleeve bearings for aerospace systems. These design requirements are peculiar to these types of bearings and are to be used as a supplement to design requirements specified in Requirement 201. This requirement also identifies the presently approved lined sleeve bearings for aerospace applications.

6.1.1 Installation and retention. Sleeve bearings are designed to be installed and retained using a press/interference fit. Recommended housing and shaft fits for installation of the bearings shall be as specified in Requirement 202. Adhesive can be used to aid in the retention, but care shall be taken to avoid installations which rely on adhesive as the sole means of retaining the bearing in an oversized hole. Adhesive brittle failure may occur in such cases.

6.2 Issue of DODISS. When this requirement is used in acquisition, the issue of the DODISS to be applicable to this solicitation must be cited in this solicitation (see 2.1.1 and 2.2).

MIL-HDBK-1599A

REQUIREMENT 311

### LINEAR MOTION ANTI-FRICTION BEARINGS

Linear motion anti-friction bearings are not ordinarily used as airframe bearings. Consequently, no parts are listed for use in this requirement. Unless specifically prohibited by Requirement 201, the usage of this type of bearings as an airframe bearing shall be governed by the application of the procedure described in Requirements 101 and 102.

A linear ball bearing is described as a cylindrically configured bearing containing three or more oblong ball circuits (see Figure 201-1). The ball circuits are arranged so that the balls may roll longitudinally between the inner surface of the bearing sleeve and the surface of the shaft. The load and motion are sustained by the balls in the contact portion of each circuit while the balls in the return portion of each circuit circulate freely and "refill" the contact zone. This design permits unlimited linear travel along the axis of the supporting shaft.

To date, there has been no known use of a linear ball bearings as an airframe bearing in an aerospace vehicle. There are no standards for these bearings at this time.

MIL-HDBK-1599A

REQUIREMENT 312

SPECIAL PURPOSE BEARING DESIGNS

1. Scope. This requirement defines “special purpose bearing design”, the applicability of this term and the procedures for approval and use of such a bearing when MIL-HDBK-1599 is contractual. Bearings which comply with the definition of special purpose bearing design are considered outside of the scope of standard parts as defined in MIL-HDBK-1599.

1.1 Applicability. A bearing is a special purpose design when it meets the criteria of 3.1. Examples of special purpose bearing design are wing pivot bearings, horizontal tail bearings, or helicopter pitch link bearings.

2. Applicable documents.

DOD-D-1000	Drawings, Engineering and Associated Lists
DOD-STD-100	Engineering Drawing Practices

3. Usage and approval of special purpose bearing designs.

3.1 Definition. A special purpose bearing design is one to which both of the following apply:

- a. Testing is required per criteria applicable to a specific or peculiar design usage;
- b. A specification control drawing in accordance with DOD-D-1000, level 3, DOD-STD-100, or equivalent, is prepared and the part is identified in accordance with the procedures therein.

**NOTE:** The term “special purpose bearing design” does not apply when the part is a modified part as defined in Requirement 107, or when the part is identified in accordance with DOD-D-1000, level 3, DOD-STD-100, or equivalent, for contractor or procuring agency convenience or for source or inspection control only.

3.2 Technical requirements. Special purpose bearing designs are designed and qualified for specific applications having special design criteria and performance requirements. Selection guidance in Sections 100 and 200 of MIL-HDBK-1599 does not dictate technical requirements for special purpose bearing designs.

3.3. Engineering approval of special purpose bearing designs. Engineering approval of special purpose design bearings is accomplished by conducting tests on the bearing which simulate the actual conditions of the application. In the following circumstances, approval by similarity is an acceptable alternative:

- a. The bearing is a logical size extensive or a variation of an existing standard series of bearings, but not more than 50% larger in an dimension than the largest standard bearing; or
- b. The bearing is an application of proven bearing technology in a unique bearing configuration or a special application and the performance of the bearing can be accurately predicted based on similarity to other applications.

3.4 Approval. Special purpose bearing designs are considered unapproved parts shall be submitted for approval in accordance with Requirement 101.

MIL-HDBK-1599A

REQUIREMENT 313

BEARINGS, SLEEVE, NON-METALLIC, SELF-LUBRICATION

1. Scope. This requirement establishes engineering criteria for self-lubricating, non-metallic sleeve bearings for aerospace systems. These design requirements are peculiar to these types of bearings and are to be used as a supplement to design requirements specified in Requirement 201. This requirement also identifies the presently approved lined sleeve bearings for aerospace applications.

2. Documents applicable to requirement 313.

MIL-B-85560  
MIL-B-85560/1  
MIL-B-85560/2

3. General. Sleeve bearings have a simple cylindrical construction that may or may not be flanged. The self-lubricating lining can be either bonded to the inside diameter of the bearing and the external surface of the flange (when used) or be an integral part of the composite substrate. Similar to plain spherical bearings, sleeve bearings allow a load to be transmitted from one structural member into another and permit rotational movement along the axis of the bearing between the two parts. These bearings, however, do not have misalignment capability.

4. Design requirements.

4.1 Approved parts. M85560/1 and M85560/2 bearings shall be used in design and procured from qualified manufacturers as listed on the applicable qualified products list for MIL-B-85560. These bearings are approved for use in new design, modification, or repair of aerospace vehicles or ground support equipment. Sleeve bearings other than those listed above must be approved by the acquisition activity for each application.

4.2 Materials and finish. The materials and finish of the bearings shall be in accordance with the applicable military standard or drawing.

4.3 Design. Bearing design conforms to that specified on the applicable military standard or drawing. Special design applications shall not exceed a length to bore ratio of 5:1

4.4 Dimensions and tolerances. Dimensions and tolerances are as specified on the applicable military standard or drawing. Dimensions not shown shall be at the option of the manufacturer.

4.5 Surface texture. Surface texture shall be in accordance with the applicable military standard or drawing.

4.6 Lubrication. Lined sleeve bearings do not require initial or relubrication since the liner is self-lubricating. The liners are sacrificial. The wear rate can be accelerated by liquid contaminants and even oils or greases especially in dirty conditions.

4.7 Temperature range. These sleeve bearings shall not be used in applications which exceed the temperature limits of -65 °F and +250 °F as listed in the military standard or drawing.

MIL-HDBK-1599A

REQUIREMENT 313

5. Performance.

5.1 Static radial limit load. The static radial limit load is the maximum radial load applied to the bearing and housing which may result in a maximum permanent set as defined in the applicable military standard or drawing. For static limit load capacity calculations, see the calculations for lined sleeve bearings in Requirement 201.

5.2 Dynamic (oscillating) radial load rating. The dynamic radial load is the load which is applied to the bearing and mating pin. The oscillation angle, number of cycles, and corresponding maximum wear allowed is defined in the applicable military standard and drawing. For dynamic load capacity calculations, see the lined sleeved bearing calculations in Requirement 201.

6. Installation and retention. Composite sleeve bearings are usually retained with either a press fit or adhesive bonding depending on the material of the support structure. Adhesive bonding requires a clearance fit for proper adhesive film thickness. Mechanical fastening devices can also be used for retention.

MIL-HDBK-1599A

REQUIREMENT 401

RETAINING RINGS

1. Scope. This requirement establishes the approved retaining rings for use in bearing and seal retention other than seals integral within a bearing assembly.

2. Applicable Documents

GGG-P-840	Pliers, Retaining Ring, Hog Ring Staple (Upholsterer S), Brake Repair Brake Spring and Hose Clamp (Wire)
MIL-R-21248	Rings, Retaining, (Tapered and Reduced Section)
MIL-R-27426	Ring, Retaining, Spiral (Uniform Cross Section)
MS3215	Ring, Retaining, External, E Reinforced (Reduced Section Type)
MS3216	Ring, Retaining, External, Prong Look (Reduced Section Type)
MS3217	Ring, Retaining, External, Heavy Duty (Tapered Section Type)
MS16624	Ring, Retaining, External, Basic (Tapered Section Type)
MS16625	Ring, Retaining, Internal, Basic (Tapered Section Type)
MS16626	Ring, Retaining, External, Inverted (Tapered Section Type)
MS16627	Ring, Retaining, Internal, Inverted (Tapered Section Type)
MS16628	Ring, Retaining, External, Bowed (Tapered Section Type)
MS16629	Ring, Retaining, Internal, Bowed (Tapered Section Type)
MS16630	Ring, Retaining, External, Beveled (Tapered Section Tape)
MS16631	Ring, Retaining, Internal, Beveled (Tapered Section Tape)
MS16632	Ring, Retaining, External, Crescent (Reduced Section Tape)
MS16633	Ring, Retaining, External, E (Reduced Section Type)
MS16634	Ring, Retaining, External, Bowed E (Reduced Section Type)
MS90707	Ring, Retaining, External, Grip
MS90708	Ring, Retaining, External, Interlocking

3. Design usage of retaining rings.

3.1 Approval retaining rings. All retaining rings listed in Section 2 of this requirement are approved for use in appropriate applications for bearing and seal retention in aerospace vehicle or ground support equipment. Retaining rings which are an integral component of a bearing assembly or other part supplied as a non-repairable part are not intended to be controlled by this requirement. All retaining rings used for component retention which are of the reduced (tapered) or spiral (uniform) section type shall conform to the requirements of MIL-R-21248 or MIL-R-27426 as specified on the applicable military standard listed in Section 2.

3.2 Retaining ring usage. Usage requirements for bearing retention in a housing or on a shaft are specified in Requirement 202. The following are supplemental requirements relative to retaining ring usage.

3.2.1 Shaft and housing design. Design of shafts or housings and grooves for retaining rings shall be in accordance with conditions specified in the applicable military standards.

3.2.2 Bearing. Retaining rings which bear against the inner or outer race of bearings shall be of such width  $(O.D. - I.D.) / 2$  that at least 50 percent of this width is in contact with the bearing after the groove and bearing chamfer or radius is considered.

MIL-HDBK-1599A

REQUIREMENT 401

3.2.3 Sealing. When retaining rings are used for seal retention, the seal not being an integral part of the bearing, the assembly shall not be designed so that deflection of the retaining ring under load will reduce the extent to which the seal is compressed or squeezed.

3.2.4 Loading.

3.2.4.1 Allowable axial load. Retaining rings shall not be subjected to loads exceeding either the recommended allowable thrust load capability for the retainer per the military standard or 50 percent of the shear capacity of the retainer, whichever is lower.

3.2.4.2 Shock loads. Retaining rings shall not be used in applications that subject them to shock loads unless the installation has been tested for these shock loads and fatigue life is proven satisfactory.

3.2.4.3 Allowable bending load. Retaining rings shall not be subjected to bending loads during installation sufficient to yield the ring. Yielding by bending is indicated by play between the groove diameter and the inside ring diameter after installation.

3.3 Relative rotation. Retaining rings shall not be used in bearing retention applications where relative rotation between the ring and the portion of the bearing contacted by the ring is a requirement of the functional system as designed. Incidental relative rotation should be kept minimal or avoided where possible.

3.4 Checking of ring assembly. Adherence to requirements for checking proper ring assembly (dimension K) on the applicable military standard is required.

3.5 Temperature limits.

3.5.1 Cadmium plated steel rings. Cadmium plated steel rings shall not be used at temperatures which exceed 450°F.

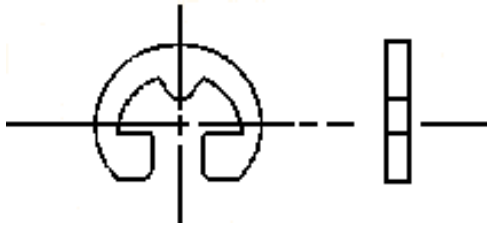
3.5.2 Corrosion-resistant steel rings. Corrosion-resistant steel rings shall not be used at temperature which exceed 700°F.

4. Retaining ring selection. Retaining rings shall be selected, and specified by part number, from the standards or specifications listed in table 401-I. The intended use is briefly specified for use in selection considerations. MS16624, MS16625, MIL-R-27426, type A, class 2, and MIL-R-27426, type B, class 2, are the preferred series and should be used whenever they meet design requirements.

5. Tools. Retaining pliers and other specifically designed installation tooling shall be used for installation and removal of retaining rings in accordance with GGG-P-480.

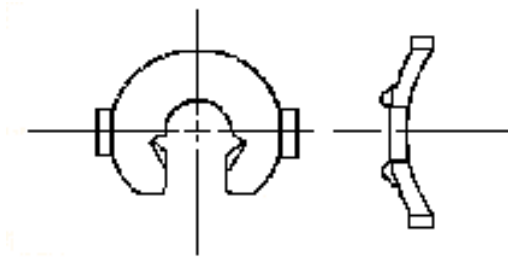
TABLE 401-I. Retaining ring selection

MS3215 - Ring, Retaining, External, E Reinforced (Reduced Section Type)



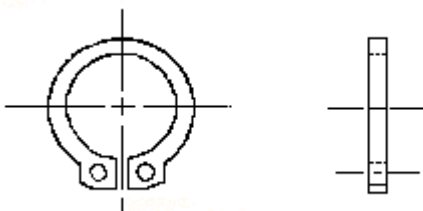
Intended use: To provide unusually large shoulders for positioning and maintaining machine components on shafts. They are applied radially and withstand strong pushout forces resulting from heavy vibrations and shook loads, high rotational speeds, or relative rotation between the retained parts. They are of further advantage where axial assembly of a retaining ring is not possible and where fast assembly for mass production lines is essential.

MS3216 - Ring, Retaining, External, Prong-Look (Reduced Section Type)



Intended use: To provide large shoulders for positioning and maintaining machine parts. They are applied radially and are looked positively in their grooves by means of two prongs extending from the inner circumference to the open end. They withstand high thrust loads and relative rotation between the retained parts. Their bowed construction provides resilient end-play take up in axial direction; however, they are not intended to take axial loads.

MS3217 - Ring, Retaining, External, Heavy Duty (Tapered Section Type)



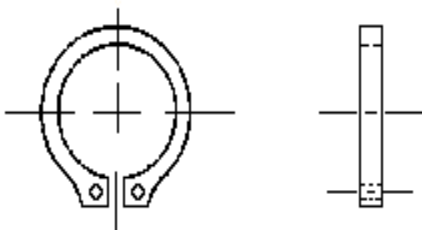
Intended use: To provide large shoulders for positioning and retaining machine components under heavy loading conditions on shafts, even if components to be secured have large corner radii or chamfers abutting the rings. They withstand comparatively heavy load loads and high rotational speeds. They eliminate the need for separate thrust washers.

MIL-HDBK-1599A

REQUIREMENT 401

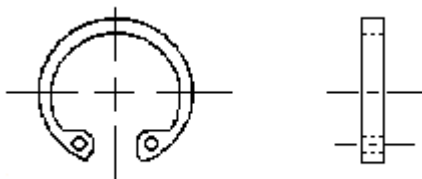
TABLE 401-I. Retaining ring selection. - Continued

MS16624 - Ring, Retaining, External, Basic (Tapered Section Type)



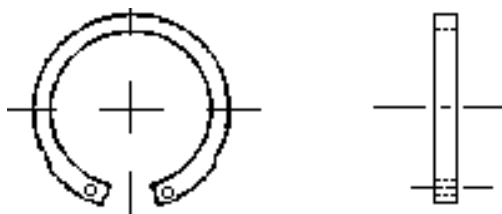
Intended use: To provide shoulders for positioning and retaining machine components on shafts. Tapered design principle permits rings to maintain practically constant circularity and pressure against bottom of groove, counteracting considerable centrifugal force. Rings for shaft diameters over 4 inches are specially dimensioned to maintain balance in rotation.

MS16625 - Ring, Retaining, Internal, Basic (Tapered Section Type)



Intended Use To provide shoulders for positioning and retaining machine components in housings (bores). Tapered design principle permits rings to maintain constant circularity and pressure against bottom of groove.

MS16626 - Ring, Retaining, External, Inverted (Tapered Section Type)



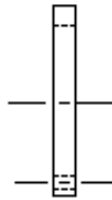
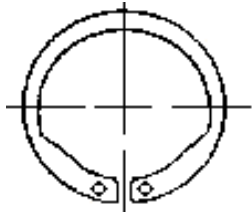
Intended use: To provide uniform protruding shoulders for positioning and retaining machine components on shafts. Tapered design principle permits rings to maintain practically constant circularity and fit securely against bottom of groove, counteracting considerable centrifugal force. Especially suited for locating and retaining machine parts having curved abutting surface.

MIL-HDBK-1599A

REQUIREMENT 401

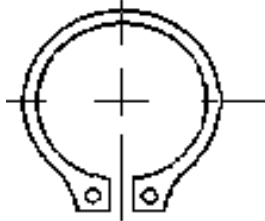
TABLE 401-I. Retaining ring selection. - Continued

MS16627 - Ring, Retaining, Internal, Inverted (Tapered Section Type)



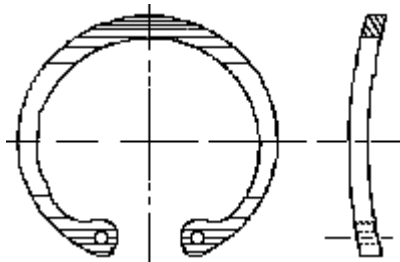
Intended use: To provide uniform protruding shoulders for positioning and retaining machine components in housings (bores). Tapered design principle permits rings to maintain practically constant circularity and fit securely against bottom of the groove. Especially suited for locating and retaining machine parts having curved abutting surfaces.

MS16628 - Ring, Retaining, External, Bowed (Tapered Section Type)



Intended Use: To provide shoulders for positioning and retaining machine components on shafts. The rings are bent like a bow out of plane. Free ends and opposite edge abut machine part, mid-section of rings abuts outer groove wall. The ring will counteract considerable centrifugal forces. Ring will take up end play resiliently.

MS16629 - Ring, Retaining, Internal, Bowed (Tapered Section Tape)



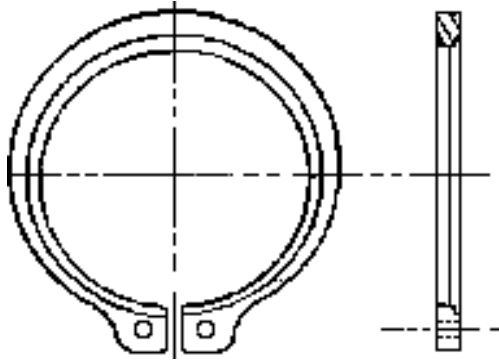
Intended use: To provide shoulders for positioning and retaining machine components in housings (bores). The rings are bent like a bow out of plane. Free ends and opposite edge abut outer groove wall. Mid-section of ring abuts machine part. Ring will take up end lay resiliently.

MIL-HDBK-1599A

REQUIREMENT 401

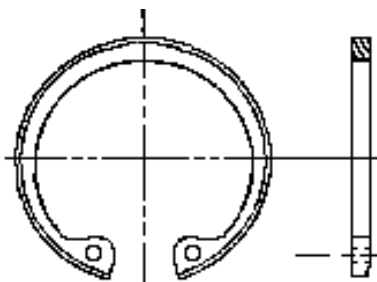
TABLE 401-I. Retaining ring selection. - Continued

MS16630 - Ring, Retaining, External, Beveled (Tapered Section Type)



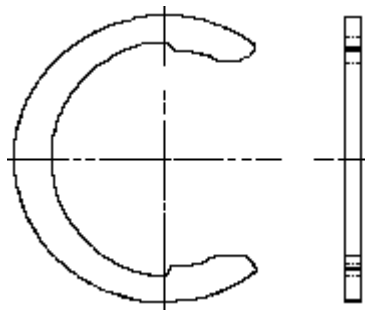
Intended use: To provide shoulders for positioning and retaining machine 40 components on shafts. Tapered design principle permits a rings to maintain practically constant circularity within the limits of expansion in normal use. The rings with bevel in inner circumference and when spring into groove with tapered outer wall corresponding to ring bevel, will self adjust and provide secure pressure fit axially to take up end play. The ring will counteract considerable centrifugal forces and will be secure against high rpms.

M316631 - Ring, Retaining, Internal, Beveled (Tapered Section Tape)



Intended use: To provide shoulders for positioning and retaining machine components in housings. Tapered design principle permits ring to maintain practically constant circularity. The rings with bevel on outer circumference and when sprung into groove with tapered outer wall corresponding to ring bevel will self adjust and provide secure pressure fit axially to take up end play.

MS16632 - Ring, Retaining, External, Crescent (Reduced Section Type)



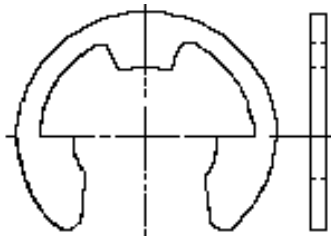
Intended use: To provide shoulders for positioning and maintaining machine parts on shaft which are axially inaccessible in assembly. They are applied radially and, because of deep grooves, have high thrust capacity. They are of advantage where fast assembly for mass production linen is essential and-where-comparatively small clearance diameters are desirable.

MIL-HDBK-1599A

REQUIREMENT 401

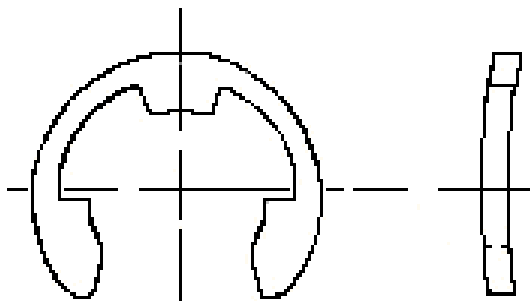
TABLE 401-I. Retaining ring selection. - Continued

MS16633 - Ring, Retaining, External, E (Reduced Section Type)



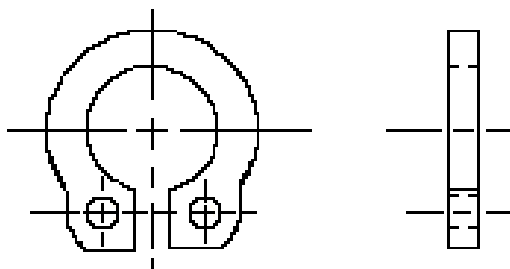
Intended use: To provide unusually large shoulders for positioning and maintaining machine components on shafts. They are applied radially and withstand considerable thrust load. They are advantageous where axial assembly of a retaining ring is not possible and where fast assembly for mass production lines is essential.

MS16634 - Ring, Retaining, External, Bowed E (Reduced Section Type)



Intended use: To provide usually large shoulders for positioning and maintaining machine components on shafts. They are applied radially and withstand considerable thrust load. The rings are bent like a bow out of plane. Free ends and opposite ends about the machine part, midsection of ring abuts outer groove wall. Ring will take up end play resiliency. They are of advantage where axial assembly of a bowed retaining ring is not possible.

MS90707 - Ring, Retaining, External, Grip



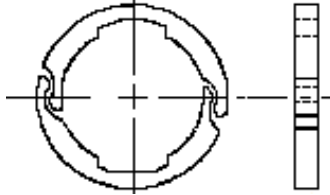
Intended use: To provide shoulders for positioning and retaining machine components on ungrooved shafts, tubes, bosses, studs, etcetera. Friction force caused by heavy spring pressure of ring on shaft makes a fastener secure against axial displacement from either direction under moderate thrust or vibration. The rings are adjustable on the shaft and are reusable following disassembly. The rings will withstand high rotational speeds.

MIL-HDBK-1599A

REQUIREMENT 401

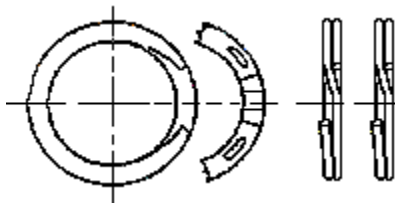
TABLE 401-I. Retaining ring selection. - Continued

MS90708 - Ring, Retaining, External, Interlocking



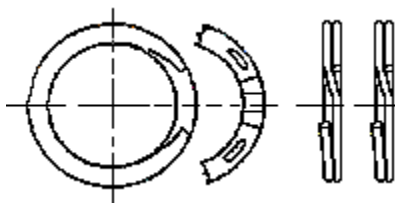
Intended use: To provide high circular shoulders for positioning and retaining machine components on shafts. The identical semicircular halves held together by the interlocking prongs form a balanced ring concentric with the shaft which will withstand high rotational speeds.

MIL-R-27426, type A, class 1 - Ring, Retaining, Spiral, External, Light Series (Uniform Cross Section)



Intended use: To provide shoulders for positioning and retaining components on shafts. Provides a continuous uniform retaining shoulder. No special tools required to install or remove rings. Moderate thrust capacity.

MIL-R-27426, type A, class 2 Ring, Retaining, Spiral, External, Heavy Series (Uniform Cross Section)



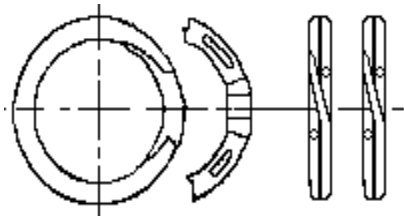
Intended use: To provide shoulders for positioning and retaining components on shafts. Provides a continuous uniform retaining shoulder. No special tools required to install or remove rings. High thrust capacity.

MIL-HDBK-1599A

REQUIREMENT 401

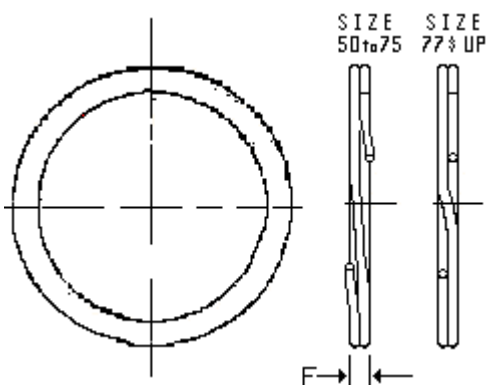
TABLE 401-I. Retaining ring selection. - Continued

MIL-R-27426, type B, class 1 - Ring, Retaining, Spiral, Internal Light Series (Uniform Cross Section)



Intended use: To provide shoulder for positioning and retaining components in housing or bores. Provides a continuous uniform retaining shoulder. No special tools required to install or remove rings. Moderate thrust capacity.

MIL-R-27426, type B, class 2 Ring, Retaining, Spiral, Internal, Heavy Series (Uniform Section Type)



Intended use. To provide shoulder for positioning and retaining components in housing or bores. Provides a continuous uniform retaining shoulder. No special tools required to install or remove rings. High thrust capacity.

MIL-HDBK-1599A

REQUIREMENT 402

NUTS AND LOCKING DEVICES

1. SCOPE

1.1 Scope. This requirement establishes the nuts and locking devices for use in assembly of rod end bearings, control rods, and associated hardware.

2. APPLICABLE DOCUMENTS

2.1 Government documents

2.1.1 Specifications, standards, and handbooks. The following specifications, standards, and handbooks form a part of this document to the extent specified herein. Unless otherwise specified, the issue of these documents are those listed in the issue of the Department of Defense Index of Specifications and standards (DODISS) and supplement thereto, cited in the solicitation (see 6.2)

SPECIFICATIONS

MILITARY

MIL-B-81935/3 Locking Device, Rod End

STANDARDS

MILITARY

MS 14198	Lock, Rod End, Extra Strength, High Profile Lug
MS 14227	Lock, Rod End, Improved Strength, NAS Lug
MS 20995	Wire-Safety or Lock
MS 24665	Pin-Cotter (split)

(Unless otherwise indicated, copies of federal and military specifications, standards, and handbooks are available from the Naval Publications and Forms Center, (ATTN: NPODS), 5801 Tabor Avenue, Philadelphia, PA 19120-5099.)

2.1.2 Other Government documents, drawings, and publications. The following other Government documents, drawings, and publications form a part of this document to the extent specified herein. Unless otherwise specified, the issues are those cited in the solicitation.

DODISS - Department of Defense Index of Specifications and Standards.

(Copies of the DODISS are available on a yearly subscription basis either from the Government Printing Office hard copy, or microfiche copies are available from the director, Navy publications and Printing Service Office, 700 Robins Avenue, Philadelphia, PA 19111-5093.)

MIL-HDBK-1599A

REQUIREMENT 402

2.2 Non-Government publications. The following documents form a part of this document to the extent specified herein. Unless otherwise specified, the issues of the documents which are DoD adopted are those listed in the issue of the DODISS cited in the solicitation. Unless otherwise specified, the issues of documents not listed in the DODISS are the issues of the documents cited in the solicitation (see 6.2)

STANDARDS

INDUSTRY

NAS 513 Washer Rod End Locking  
NAS 559 Lock - Rod End (Key Type)  
NAS 1193 Locking Device, Positive Index

(Copies of the above publication may be obtained from the American National Standards Institute, ATTN: Sales Dept., 1430 Broadway, New York, NY 10018-3363.)

2.3 Order of precedence. In the event of a conflict between the text of this document and the references cited herein, (except for related associated detail specifications, specification sheets, or MS standards), the text of this document takes precedence. Nothing in this document, however, supersedes applicable laws and regulations unless a specific exemption has been obtained.

3. DEFINITIONS

This section is not applicable to this requirement.

4. GENERAL REQUIREMENTS

4.1 Locking devices approved for new and existing design. The following locking devices are approved for use in new and existing design subject to the limitations discussed in 6.1.1.1 and 6.1.1.2. MS14227 is the preferred locking device for existing design.

MIL-B-81935/3	Locking Device, Rod End
MS 14198	Lock, Rod End, Extra Strength, High Profile Lug
MS 14227	Lock, Rod End, Improved Strength, NAS Lug
NAS 559	Lock - Rod End (Key Type)
NAS 1193	Locking Device, Positive Index

4.1.1 Locking devices. For new design, MS 14198 or NAS 1193 locks shall be used. MS 14198 locks are specified because of extra strength properties, and because the high profile lug creates an obvious mismatch if improperly installed making inspection for proper engagement easier. If close adjustment of threaded components is needed, NAS 1193 shall be used in lieu of MS 14198.

MIL-HDBK-1599A

REQUIREMENT 402

4.2 Unapproved locking devices. (see 6.1.1.2)

NAS 513 Washer - Rod End

4.3 Safety wire and cotter keys.

MS 20995 Wire Safety or Lock

MS 24665 Pin Cotter (split)

5. DETAIL REQUIREMENTS

This section is not applicable to this requirement.

6. NOTES

6.1 Intended use. This requirement is intended to establish the nuts and locking-devices for use in assembly of rod end bearings, control rods, and associated hardware.

6.1.1 Locks.

6.1.1.1 Suitable locks. MS 14227 was developed to provide a stronger rod end lock for use in existing design and which would be compatible with NAS 513 and NAS 559 lug slot dimensions in threaded sizes up to 1.125 inch diameter. For larger diameters, the MS 14198 locks are compatible with NAS 513 and NAS 559 lug slot dimensions and offer a retrofittable lock having greater strength.

6.1.1.2 Unsuitable locks. Use of NAS 559 Type A locks in sizes smaller than the 4 (9/16" thread size) should be discontinued because of poor strength. Mechanically formed locks, such as NAS 559 Type B, and stamped-out (not machined) NAS 513 locks should also be discontinued from service because of poor strength and susceptibility to installation damage which may go undetected.

6.2 Issue of DODISS. When this requirement is used in acquisition, the issue of the DODISS to be applicable to this solicitation must be cited in this solicitation (see 2.1.1 and 2.2).

MIL-HDBK-1599A

REQUIREMENT 501

LUBRICATION FITTINGS

1. SCOPE

1.1 Scope. This requirement establishes standard design practices for the use of fittings required to provide grease lubrication of bearings and bearing surfaces as described in Requirement 203.

2. APPLICABLE DOCUMENTS.

2.1 Government documents

2.1.1 Specifications, standards, and handbooks. The following specifications, standards, and handbooks form a part of this document to the extent specified herein. Unless otherwise specified, the issue of these documents are those listed in the issue of the Department of Defense Index of Specifications and standards (DODISS) and supplement thereto, cited in the solicitation (see 6.2)

STANDARDS

MILITARY

MS 15001	Fittings, Lubrication (Hydraulic) Surface Check, 1/4 -28 Taper Threads, Steel Type I
MS 15002	Fittings, Lubrication (Hydraulic) Surface Check, Straight Threads, Steel Type II
MS 15004	Fittings, Lubrication (Hydraulic) Surface Check, 1/4- 28 Threads. Nickel Cooper Alloy Type IV
MS 15720	Fittings, Lubrication (Hydraulic) Throat or Surface Check, 1/4-28 Taper Threads, Corrosion-Restraint Steel, Type VII

(Unless otherwise indicated, copies of federal and military specifications, standards, and handbooks are available from the Naval Publications and Forms Center, (ATTN: NPODS), 5801 Tabor Avenue, Philadelphia, PA 19120-5099.)

2.1.2 Other Government documents, drawings, and publications. The following other Government documents, drawings, and publications Form a part of this document to the extent specified herein. Unless otherwise specified, the issues are those cited in the solicitation.

DODISS - Department of Defense Index of Specifications and Standards.

(Copies of the DODISS are available on a yearly subscription basis either from the Government Printing Office hard copy, or microfiche copies are available from the director, Navy publications and Printing Service Office, 700 Robins Avenue, Philadelphia, PA 19111-5093.)

MIL-HDBK-1599A

REQUIREMENT 501

2.2 Non-Government publications. The following documents form a part of this document to the extent specified herein. Unless otherwise specified, the issues of the documents which are DoD adopted are those listed in the issue of the DODISS cited in the solicitation. Unless otherwise specified, the issues of documents not listed in the DODISS are the issues of the documents cited in the solicitation (see 6.2)

STANDARDS

INDUSTRY

NAS 516 Fittings, Lubrication 1/8' Drive, Flush Type

(Copies of the above publication may be obtained from the American National Standards Institute, ATTN: Sales Dept., 1430 Broadway, New York, NY 10018-3363.)

2.3 Order of precedence. In the event of a conflict between the text of this document and the references cited herein, (except for related associated detail specifications, specification sheets, or MS standards), the text of this document takes precedence, nothing in this document, however, supersedes applicable laws and regulations unless a specific exemption has been obtained.

3. DEFINITIONS

This section is not applicable to this requirement.

4. GENERAL REQUIREMENTS

4.1 Lubrication fitting usage. Lubrication fittings shall be in accordance with MS15001 (figure 1), MS 15002 (figure 2), MS15004 (figure 3), MS 15720 (figure 4), or NAS 516 (figure 5), and shall be used in accordance with Requirement 203. Of the two material options available for the NAS 516 fitting, only the NAS 516MI (Monel) is acceptable for use in Titanium. Straight fittings are the preferred installation as it is extremely difficult to install angled fittings with a particular design orientation. A straight thread fitting, as in MS 15002-1 (figure 2A) shall be used instead of a taper thread fitting, as in MS 15001-1 (figure IA), in installations where the additional stresses produced by the wedging action of the taper threads affect the performance of the part in which the fitting is installed.

5. DETAIL REQUIREMENTS

This section is not applicable to this requirement.

6. NOTES

6.1 Intended use. This requirement is intended to establish standard design practices for the use of fittings required to provide grease lubrication of bearings and bearing surfaces as described in Requirement 203.

6.2 Issue of DODISS. When this requirement is used in acquisition, the issue of the DODISS to be applicable to this solicitation must be cited in this solicitation (see 2.1.1 and 2.2).

MIL-HDBK-1599A

REQUIREMENT 501

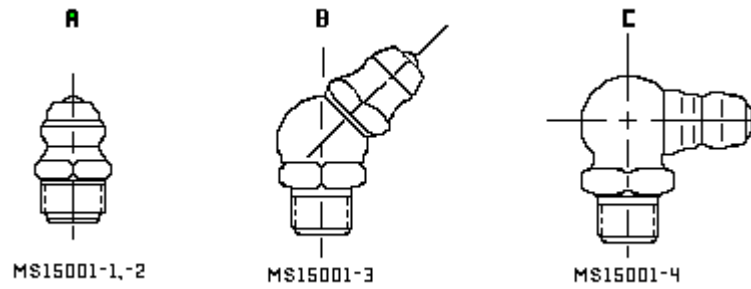


Figure 1. Lubrication Fittings (MS 15001)

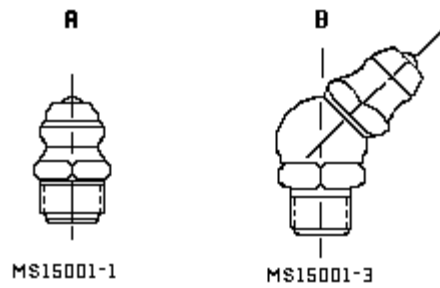


Figure 2. Lubrication Fittings (MS 15002)

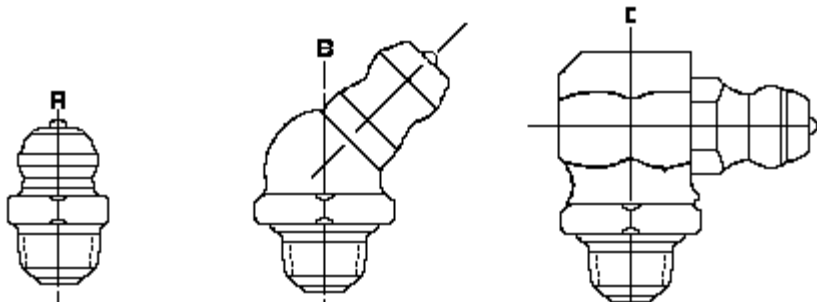


Figure 3. Lubrication Fittings (MS 15004)

MIL-HDBK-1599A

REQUIREMENT 501

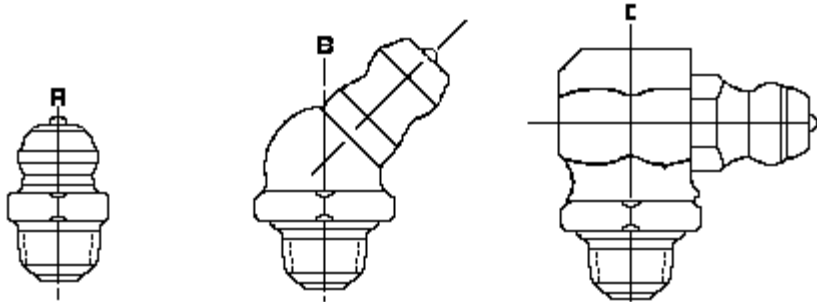


Figure 4. Lubrication Fittings (MS 15720)

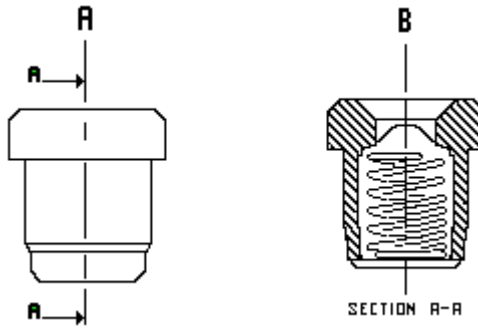


Figure 5. Lubrication Fittings (NAS 516)

MIL-HDBK-1599A

REQUIREMENT 601

CONTROL CABLE ASSEMBLY COMPONENTS

1. Scope. This requirement establishes the approved terminals (fittings), turnbuckles, turnbuckle fittings and other components used directly with mechanical control cables or attached to control cables.

2. Applicable Documents.

MIL-T-781	Terminal, Wire Rope, Swaging
MIL-C-5688	Cable Assemblies: Aircraft, Proof Testing and Restretching of
MIL-T-6117	Terminal-Cable Assemblies, Swaged Type
MIL-T-8878	Turnbuckles, Positive Locking
MIL-C-16173	Corrosion-preventive Compound Solvent Cutback, Cold Application
MIL-C-83420	Wire Rope, Flexible, For Aircraft Control
AN100	Thimble, Wire Cable
MIL-STD-143	Standards and Specifications, Order of Preference For the Selection of
MS20658	Terminal, Wire Rope, Swaging, Fork End
MS20663	Ball End, Wire Rope, Swaging, Double Shank
MS20664	Ball End, Wire Hope, Swaging, Single Shank
MS20667	Terminal, Wire Rope, Swaging, Fork End
MS20668	Terminal, Wire Rope, Swaging, Eye End
MS21251	Turnbuckle Body, Clip Locking
MS21252	Clevis End, Turnbuckle, Clip Locking
MS21253	Clevis End, Turnbuckle, Clip Locking (For Bearing)
MS21254	Eye End, Turnbuckle, Clip Locking (For Pin)
MS21255	Eye End, Turnbuckle, Clip Locking (For Wire Rope)
MS21256	Clip, Locking, Turnbuckle
MS21259	Terminal, Wire Rope, Stud
MS21260	Terminal, Wire Rope, Stud
MS51844	Sleeve, Swaging Wire Rope
NAS 287	Terminal, Chain-to-Cable (For Swaging)
NAS 1435	Terminal, Strap, Cable (Eye End and Fork End)

3. Control cable attachments and terminal connections.

3.1 Control cable. Control cable shall meet the requirements of MIL-W-83420 as noted in requirement 206.

3.2 General requirements.

3.2.1 Primary, secondary control systems, auxiliary cable system. These items are defined in paragraph 3 Definitions, of the basic MIL-HDBK-1599.

3.2.2 Terminal type. Terminal types, as used herein, are used to differentiate between swaged or crimped type terminals which may be used in primary, secondary controls and auxiliary cable systems. Types I and III are approved for all systems, type II is approved secondary controls systems and auxiliary cable systems, type IV is approved only auxiliary cable systems for items removed from aircraft before flight.

MIL-HDBK-1599A

REQUIREMENT 601

3.2.3 Terminal attachment to cable. All terminals (fittings) attached directly to cable shall be by the swaging method for all systems except the attachment of lanyards or similar systems removed from aircraft before flight. The latter may be crimped type.

3.2.4 Approved parts. All parts listed in paragraph 2 are approved within the usage criteria specified herein. Use of these parts does not require submittal of approval requests per requirement 101.

3.3 Terminal (fittings), swaged, not threaded.

3.3.1 Eye and fork type (type I).

3.3.1.1 Material and configuration. The material, configuration, and quality shall conform to MIL-T-781 and MS20658, MS20667, or MS20668.

3.3.1.2 Usage and attachment. Attachment to the cable shall be by swaging in accordance with MIL-T-6117. These fittings shall not be swaged over the cladding of Lockclad.

3.3.1.3 Strength. When gripped by a pin through the eye or fork bores, cable assemblies must withstand the ultimate tensile strength of the cable. All requirements of MIL-T-781, MIL-C-5688, and MIL-T-6117 must be met.

3.3.1.4 Safetying. With respect to the swaged terminal attachment to the cable, no further safetying is necessary or permitted.

3.3.2 Single and double shank ball ends (type I for ball, type II with NAS 1435 strap)

3.3.2.1 Material and configuration. The material, configuration, and quality shall conform to MIL-T-781 and MS20663 or MS20664.

3.3.2.2 Usage and attachment. Attachment to the cable shall be by swaging in accordance with MIL-T-6117. These fittings shall not be swaged over the cladding of Lockclad. These fittings may be used with NAS 1435 straps terminal on secondary control or auxiliary cable assemblies. These ball ends may be installed into a slot of a component and retained by the configuration of the slot or by a clevis pin and cotter pin or bolt and nut. The slot shall provide that sufficient contact between ball and housing is made to carry ultimate design load. The retaining pin shall carry no operating load. It is for the purpose of retention in the slot only.

3.3.2.3 Strength. Cable assemblies with MS20663 or MS20664, with or without the NAS 1435 strap, shall withstand the minimum breaking strength of the cable. All requirements of MIL-T-781, MIL-C-5688, and MIL-T-6117 shall be met.

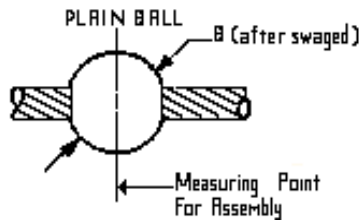
3.3.2.4 Safetying. With respect to the swaged ball end or NAS 1435 strap, no further safetying is necessary or permitted.

3.3.3 Swaged ball, no shank (type I except as noted in 3.3.3.2).

3.3.3.1 Dimensions and configuration. The dimensions and configuration shall conform to figure 601-1 and table 601-I. Balls meeting the dimensional and other requirements herein may be identified by airframe manufacturer or vendor part numbers and considered approved.

MIL-HDBK-1599A

REQUIREMENT 601



Cable Diameter, inch	B*
1/16	.19
3/32	.25
1/8	.31
5/32	.38
3/16	.44
7/32	.50
1/4	.57
9/32	.63
5/16	.69
3/8	.81

Material: Same as MIL-T-781 for swaged terminals  
 Figure 601-1. Configuration of swaged ball no  
 shank.

\*See figure 601-1.

TABLE 601-I. Dimensions of swaged ball no shank.

3.3.3.2 Usage and attachment. The swaged ball shall not be used as a terminal end on a cable used in the primary or secondary control system. It may be used on primary or secondary control cables if swaged at some point between the terminals for purposes of actuating a limit switch, signal device, or similar application. It shall not be permitted to carry structural loads. The ball is attached to the cable by the swaging method.

3.3.3.3 Strength. The ball shall hold no more than 60 percent (with the exception of the 3/64-inch size, or smaller, which is 46 percent) of the minimum breaking strength of the cable but shall not be used in a design requiring its retention to be more than 40 percent (30 percent for 3/64-inch size or smaller) of the cable strength under any condition of functioning. The ball shall be proof loaded to 40 percent (30 percent for 3/64-inch size or smaller) of the cable strength for 100 percent of assemblies. The ball shall not slip or deform at this load.

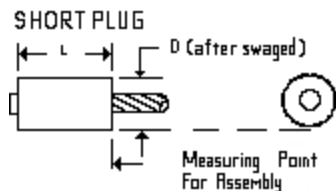
3.3.3.4 Safetying. With respect to the swaged ball attached to the cable, no further safetying is necessary or permitted.

3.3.4 Swaged plug (type II).

3.3.4.1 Dimensions and configuration. The dimensions and configuration shall conform to figure 601-2 and table 601-II. Plugs meeting the dimensional and other requirements herein may be identified by airframe manufacturer or vendor part numbers and considered approved.

MIL-HDBK-1599A

REQUIREMENT 601



Cable Diameter, inch	L*	D*
1/16	.38	.25
3/32	.50	.31
1/8	.63	.38
5/32	.69	.44
3/16	.75	.50
7/32	.88	.56
1/4	1.00	.63
9/32	1.13	.69
5/16	1.25	.75
3/8	1.56	.811

Material: Same as MIL-T-781 for swaged terminals

\*See figure 601-2.

Table 601-II. Dimensions of swaged plug.

FIGURE 601-2. Configuration of swaged plug.

3.3.4.2 Usage and attachment. The swaged cylinder may be used for the same applications as the swaged ball, no shank, and if thus used, must meet all the requirements of paragraph 3.3.3.2. It may also be used as an end terminal on cables in auxiliary systems only, such as paratroop static lines. It shall not be used as an end terminal on primary or secondary control cables. The plug is attached to the cable by swaging.

3.3.4.3 Strength. The swaged plug shall be capable of withstanding the minimum breaking strength of the cable and must meet the requirements of MIL-C-5688 and MIL-T-6117.

3.3.4.4 Safetying. With respect to the swaged plug attached to the cable, no further safetying is necessary or permitted.

3.3.5 Swaged terminal, cable to roller chain (type I)

3.3.5.1 Material and configuration. The material and configuration shall conform to NAS 287.

3.3.5.2 Attachment to cable. Attachment to, the cable shall be by Swaging in accordance with MIL-T-6117.

3.3.5.3 Strength. Cable assemblies with NAS 287 terminals must withstand the ultimate breaking strength of the cable. All requirements of MIL-T-781, MIL-C-5688, and MIL-T-6117 shall be met.

3.3.5.4 Safetying. With respect to the swaged terminal, no further safetying is necessary or permitted.

3.3.6 Swaged terminals for lockclad cable assemblies (type III).

3.3.6.1 Material and configuration. The terminal material shall be of corrosion-resistant ferrous base capable of being swaged per MIL-T-6117. The configuration may be to the requirements of the contractor identified by contractor or terminal manufacturer's part number. Detailed terminals shall be submitted for approval per requirement 101.

MIL-HDBK-1599A

REQUIREMENT 601

3.3.6.2 Attachment. These terminals shall be swaged over the cladding of the lockclad cable. Terminals swaged directly to the cable, even though the assembly includes lockclad, are not covered by this paragraph and shall meet the requirements in the section of this requirement applicable to the specific type terminal used. The end of the terminals covered by this paragraph which are not swaged shall meet the requirements of the applicable section of this requirement regarding connection and safetying. If the connection does not resemble standard connections, the contractor may use his method provided it meets the requirements of paragraph 3.3.6.

3.3.6.3 Strength. Swaged terminals swaged over the cladding shall meet the minimum breaking strength of the base cable over which the cladding is applied both in swaging and structural configuration of the terminal. Lockclad assemblies shall meet the requirements of MIL-C-5688 and MIL-T-6117.

3.3.6.4 Safetying. If the terminal mates with a turnbuckle, it shall be capable of the clip lock safetying method and therefore safetyed per the herein approved turnbuckle assembly safetying practice. If the terminal ends in an eye, fork, or stud, safetying shall comply with the requirements for other eyes, forks, or studs covered herein. If other configuration connections are used, the contractor shall furnish a company standard for the safetying procedure or define explicit requirements on the appropriate drawings for safetying requirements.

3.4 Terminals (fittings), swaged and threaded.

3.4.1 Swaged, thread for use with turnbuckles (type D).

3.4.1.1 Material and configuration. The material, configuration, and quality shall conform to MIL-T-6117 and MS21260.

3.4.1.2 Attachment. Attachment to the cable shall be by swaging in accordance with MIL-T-781. These fittings shall not be swaged over the cladding of clad cable.

3.4.1.3 Strength. When held by the terminal threads, cable assemblies shall withstand the minimum breaking strength of the cable. All requirements of MIL-T-781, MIL-C-5688, and MIL-T-6117 shall be met.

3.4.1.4 Safetying. With respect to the swaged terminal attached to the cable, no further safetying is necessary or permitted. See paragraph 3.8.1, "Turnbuckle assembly", for assembly and safetying of turnbuckle assemblies.

3.4.2 Swaged, threaded shank (type D).

3.4.2.1 Material and configuration. The material, configuration, and quality shall conform to MIL-T-6117 and MS21259.

3.4.2.2 Usage and attachment. Attachment to the cable shall be by swaging in accordance with MIL-T-781. These fitting shall not be swaged over the cladding of clad cable. MS21259 shall not be used with turnbuckles. It may be used for attachment to bell cranks or other components by running through a hole with an approved self-locking nut on the opposite end. MS21259 shall not be threaded into a closed-end tapped hole.

3.4.2.3 Strength. When held by the terminal threads, cable assemblies shall withstand the minimum breaking strength of the cable. All requirements of MIL-T-781, MIL-C-5688, and MIL-T-6117 shall be met.

MIL-HDBK-1599A

REQUIREMENT 601

3.4.2.4 Safetying. With respect to the swaged terminal attached to the cable, no further safetying is necessary or permitted. The self-locking nut shall be safety wired to the component through which the terminal passes in primary or secondary control systems. A cotter pin or any method requiring a hole through the terminal is not permitted. The self-locking nut may be safety wired in auxiliary cable systems at the option of the design activity.

3.5 Turnbuckle assembly components.

3.5.1 Turnbuckle barrel (type D).

3.5.1.1 Material and configuration. The material, configuration, and quality shall conform to MIL-T-8878 and MS21251. Steel turnbuckles are not approved for aircraft use.

3.5.1.2 Usage. The MS21251 aluminum and brass turnbuckles are approved for primary controls, secondary controls, and auxiliary cable assemblies. The appropriate size turnbuckle shall be used for the applicable size cable as noted on MS21251.

3.5.1.3 Strength. The MS21251 aluminum and brass turnbuckles shall withstand the minimum breaking strength of the appropriate size cable. Size selection shall be on this basis.

3.5.1.4 Safetying. MS21256 shall be used. See requirement 206.

3.5.2 Eye and fork fittings, threaded (type D).

3.5.2.1 Material and configuration. The material, configuration, and quality shall conform to MS21253, MS21254, MS21255, or MIL-T-8878 and MS21252.

3.5.2.2 Usage. The appropriate size eye or fork shall be used for the applicable size cable as noted on the MS drawings.

3.5.2.3 Strength. These fittings shall withstand the ultimate strength of the appropriate size cable. Size selection will be on this basis.

3.5.2.4 Safetying. See requirement 206.

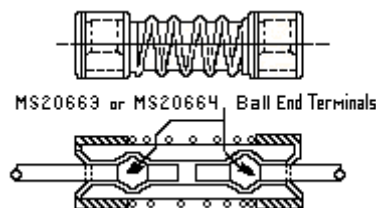


FIGURE 601-3. Ball-end terminal quick connect.

MIL-HDBK-1599A

REQUIREMENT 601

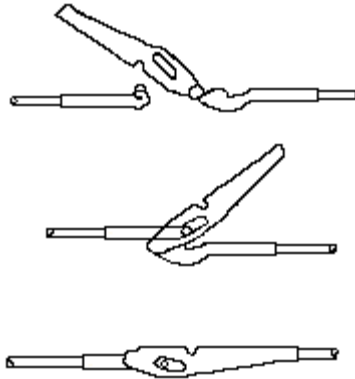


FIGURE 601-4. Turnbuckle type and swage type quick disconnects.

### 3.6 Quick disconnects.

3.6.1 Configuration. The configuration shall conform to figures 601-3 (type and 601-4 (type I) and shall conform to vendor products qualified by aerospace contractors to the requirements and to other applicable considerations.

3.6.2 Usage. See requirement 206, paragraph 3.1.4.5.

3.6.3 Strength. The quick disconnect must be capable of withstanding the minimum breaking strength of the cable.

3.6.4 Safetying. Safetying is not required for ball end disconnect. Use safety wire as shown for the turnbuckle-swaged terminal type in figure 601-4.

### 3.7 Cable take-up links (type I).

3.7.1 Material and configuration. Cable take-up links shall consist of two side plates of material and thickness in accordance with requirements of this standard with holes drilled in the side plates and shear bolts and self-locking nuts installed in two of the holes. Company standard or vendor part numbers may be used for the link assembly. Shear bolts and nuts shall comply with the requirements of this standard.

3.7.2 Usage and attachment. See requirement 206.

3.7.3 Strength. The thickness of material of side plates and shear strength of bolts shall be sufficient to withstand the minimum breaking strength of the size and material cable assemblies which shall be connected by the link assembly.

3.7.4 Safetying. Safetying, in addition to self-locking fasteners, is at the option of the contractor.

### 3.8 Connection and safetying of control cable assemblies.

MIL-HDBK-1599A

REQUIREMENT 601

3.8.1 Turnbuckle assembly.

3.8.1.1 Assembly procedure. See requirement 206.

3.8.1.2 Safetying. See requirement 206.

3.8.2 Eye-to-fork, eye- or fork-to-structure assembly.

3.8.2.1 Assembly procedure. Place eye in fork or clevis in structure or place fork over lug in structure and insert self-retaining bolt and install a castellated nut and cotter pin.

3.8.2.2 Safetying. No additional safetying is required for eye-to-eye-fork, eye- or fork-to-structure assembly.

3.8.3 Assembly of two complete lockclad assemblies.

3.8.3.1 Assembly procedure. See paragraph 3.3.6.2.

3.8.3.2 Safetying. See paragraph 3.3.6.4.

3.8.4 Quick disconnect. See paragraph 3.6.

3.8.5 Cable take-up links. See paragraph 3.7.

3.9 Auxiliary cable attachments and terminations.

3.9.1 Cable. See paragraphs 3.1 through 3.8.

3.9.2 General requirements.

3.9.2.1 Usage. All components, methods, and procedures in paragraphs 3.1 through 3.8 may be used for auxiliary cable systems.

3.10 Loop-type components and assembly (type IV).

3.10.1 General requirement. Loop-type connections shall not be used in primary controls, secondary controls, or auxiliary cable systems. They may be used for ball-lock, quick-release pins, streamers, and similar applications.

3.10.2 Crimped sleeve (type IV).

3.10.2.1 Material and configuration. Looping the cable around on AN100 thimble is recommended but not mandatory. The cable shall be looped as required and MS51844 sleeves installed by crimping with a crimping tool.

3.10.2.2 Usage and attachment. Crimped sleeves shall be used only in auxiliary applications, such as streamers for air intake scoops, where failure will not create a safety hazard and parts are removed before flight. Sleeve shall be crimped over double section of cable after looping, utilizing vendor supplied tools.

MIL-HDBK-1599A

REQUIREMENT 601

3.10.2.3 Strength. The loop sleeve shall be capable of withstanding 80 percent of the minimum breaking of the cable. Note that the AN100 will distort at this load. The requirement of MIL-C-5688 and MIL-T-6117 may be imposed at the option of the design activity. Note that ultimate tensile failure as specified in MIL-T-6117 would be 80 percent of cable strength.

3.10.2.4 Safetying. Safetying of the cable loop, sleeve, or thimble is not required. Safetying of the bolt is at the option of the design activity.

4. Design, selection and approved callout. Only the parts listed in paragraph 2 are approved, except those parts defined within this document which are designed per the details herein and are considered approved regardless of designation by contractor. All other parts required shall be selected in accordance with MIL-STD-143 prior to request for customer approval.

5. Tooling. There are not specific tooling controls required in addition to those necessary to meet the requirements of specifications and standards or delineated herein.

6. Intended use and guidance criteria. All suggestions are covered in applicable areas herein or in requirement 206.

MIL-HDBK-1599A

REQUIREMENT 602

CONTROL RODS

1. Scope. This requirement was established for the purpose of listing approved rod assemblies and components for use in primary, secondary and auxiliary controls systems. However, as of this issue of MIL-HDBK-1599, there are no standard rods or rod assemblies and a limited number of standards for components available for listing. Rod components listed are limited to safetizing devices and rod end bearings. other items shall be designed in accordance with the requirements specified in requirement 207.

2. Applicable Documents.

NAS 513           Washer, Rod End Locking  
NAS 1193         Looking Device, Positive Index

3. Control rod construction and components.

3.1 Approved control rods, assemblies and components.

3.1.2 Control rod assemblies. Control rod assemblies shall comply with requirement 207.

3.1.3 Control rod components.

3.1.3.1 Rod end bearings. Approved rod end bearings are those listed in requirement 308.

3.1.3.2 Rod safetizing devices. Rod end bearings shall be safetied by the use of NAS 513 or NAS 1193 locking devices.

3.1.3.3 All other rod components. All other rod components shall comply with requirement 207.

3.1.4 Rod construction. Rods shall be constructed in accordance with the requirements of requirement 207, insofar as those criteria apply.

3.1.5 Rod assemblies. Rod assemblies shall be configured in accordance with the requirements of requirement 207, insofar as those criteria apply.

MIL-HDBK-1599A

REQUIREMENT 603

PULLEYS, GROOVE, ANTIFRICTION BEARING,  
GREASE LUBRICATED, AIRCRAFT

1. Scope

1.1 This requirement establishes criteria and information covering metallic and nonmetallic pulleys intended for use in aircraft control systems, brake installations and such other places where pulleys of this type are covered. Pulleys identified herein are approved parts as covered by MIL-P-7034 and applicable standards and shall be given priority in design or modification programs.

1.2 Non-approved parts. When applications require pulleys not conforming to MIL-P-7034, refer to Requirements 101, 102, and 103.

2. Applicable Documents:

QQ-A-225/6	Aluminum Alloy Bar, Rod and Wire, Rolled, Drawn, or Cold Finished, 2024
TT-P-1757	Primer Coating, Zinc Chromate, Low Moisture, Sensitivity
MIL-P-7034	Pulleys, Groove, Antifriction Bearing, Grease Lubricated, Aircraft
MIL-B-7949	Bearing, Ball, Airframe, Anti-friction
MIL-A-8625	Anodic Coatings, for Aluminum and Aluminum Alloys
MIL-W-83420	Wire Rope, Flexible, for Aircraft Control
MS20219	Pulleys, Groove, Secondary Control, Aircraft
MS20220	Pulley, Groove, Flight Control, Aircraft
MS20221	Pulley, Groove, Heavy Duty Control, Aircraft
MS21443	Bearing, Ball, Airframe, Antifriction, Pulley Type
MS24566	Pulley, Control, Antifriction Bearing

3. Material requirements.

3.1 Nonmetallic sheave, type I. Nonmetallic pulley sheaves shall be manufactured from fabric or equivalent reinforcing material impregnated with a phenolic condensation product. The pulley shall be subjected to a suitable combination of temperature and pressure for producing a finished pulley with uniform strength. The material shall have non-afterglow properties and shall show no afterglow after ignition and flame extinction. The non-afterglow additive shall not bleed from the sheave material. The sheave material shall not corrode carbon steel wire rope coated with tin or zinc. The pulley shall not be adversely affected by fungus growth such as is encountered in tropical climates. Sheave material used shall be approved by the qualifying agency.

3.2 Metallic sheave, type II. Metallic sheaves shall be manufactured from aluminum alloy conforming to QQ-A-225/6, temper T351 Aluminum sheaves shall be anodized in accordance with MIL-A-8625, type II, before installing the bearing.

3.3 Bearings. Ball bearings shall conform to MIL-B-7949 and MS21443.

MIL-HDBK-1599A

REQUIREMENT 603

4. Workmanship.

4.1 Dimensions, weights, and tolerance. Dimensions, weights, and tolerance shall conform to MIL-P-7034.

4.2 Sheaves, types I and II. The sides of all pulleys shall have a smooth surface without spokes or holes. Aluminum bore surfaces shall be coated with zinc-chromate primer in accordance with TT-P-1757 before bearings are installed. The bearing shall be installed while primer is wet.

4.3 Identification of pulley. Metal stamping shall not be used for identification of pulley.

5. Performance.

5.1 Eccentricity and wobble clearance. Eccentricity and wobble clearance shall conform to MIL-P-7034.

5.2 Proof loads. Proof loads under static testing covering bearing bond, flange strength, sheave strength, and static friction torque shall conform to MIL-P-7034.

5.3 Endurance testing procedures. Endurance testing procedures shall conform to MIL-P-7034.

6. Design requirements.

6.1 Single groove pulleys. The pulleys furnished under MIL-P-7034 are intended for use with 1/16 inch through 1/4 inch flexible wire rope conforming to MIL-W-83420 as used in aircraft secondary control systems, flight control systems, and for heavy duty control applications. For recommended wire rope sizes and allowable limit loads of all pulleys, see MS20219, MS20220, MS20221 and MS24566. Both pulley and wire rope life shall be considered in designing the system.

6.2 New pulley design. For new design, the wire rope diameter, pulley groove diameter, groove configuration, and the radial limit load capacity of the bearing shall determine the maximum load of the pulley.

6.3 Quality assurance testing. Test pulleys shall be endurance tested a minimum of 50,000 revolutions using the largest diameter wire rope intended for the application, 90 degree wrap angle, 20 inch wire rope travel, and wire rope tension at 25 percent of the limit load. Test pulleys shall be sheave tested with wire rope or pressure plate equal to the diameter of the wire rope. Wrap angle shall be 120 degrees and the minimum test load shall be twice the limit load of the pulley. Flange proof loads shall be not less than 75 pounds for 3/32 inch wire rope, 175 pounds for 3/16 inch wire rope, and 250 pounds for 1/4 inch wire rope. Test procedures shall be in accordance with MIL-P-7034.

7. Notes.

7.1 Intended use. This requirement, MIL-P-7034, and the supporting documents are intended as an outline of the availability and requirements for control pulleys used in aircraft

7.2 Limitations. This requirement covers only grooved pulleys containing grease lubricated antifriction bearings. Several pulleys may be used as fairleads. Many fairlead pulleys and fairlead strips are of special design and are not covered by military specifications

MIL-HDBK-1599A

REQUIREMENT 604

BOLTS, DUAL SAFETYING

1. Scope. This requirement establishes criteria and information relative to the application of self-retaining bolts for dual safetying when used with bearings, control system components, and latch mechanisms as specified in 201, 202, 204, 206, 207, and 211. This requirement parallels Requirement 203 of MIL-STD-1515.

1.1 Classifications. Self-retaining bolts shall be of the following types.

Type I - Positive-locking bolts. Type I bolts are designed to be installed and removed after the retaining element release button is actuated to allow the locking elements to retract into the bolt body (Figure 604-1).

Type II Impedance-type bolts. Type II bolts are designed to be installed and removed by overcoming the frictional force of the retaining elements (figure 604-2).

2. Applicable Documents.

MIL-B-23964	Bolts, Self-Retaining, Positive-Locking
MIL-B-83050	Bolts, Self-Retaining, Impedance-Type
MIL-STD-1515	Fastener Systems For Aerospace Applications
MS 3369	Bolts, Self-Retaining, Positive-Locking, CRES 90 ksi $F_{su}$ , 63 ksi $F_{tu}$ , Hexagon Slotted Head, 450°F
MS 14146	Nut, Self-Locking, Castellated, Hexagon, Counterbored, Captive Washer, 450°F
MS 21125	Bolts, Self-Retaining, Positive-Locking, CRES 90 ksi $F_{su}$ 63 KSI $F_{su}$ , Pan Head, 450°F
MS 21126	Spacer, Grooved, Self-Retaining Bolt, Aluminum Alloy
MS 21128	Spacer, Grooved, Self-Retaining Bolt, CRES
MS 21130	Bolts, Self-Retaining, Positive-Locking, CRES 90 ksi $F_{su}$ ,
MS 21224	Nut, Self-Locking, Castellated, Hexagon, Counterbored, Captive Washer, 250°F, Non-Metallic Insert
MS 21244	Nut, Castellatd, Hexagon, Counterbored, Captive Washer, 450°F
MS 27576	Bolts, Self-Retaining, Impedance-Type, 95 ksi $F_{su}$ , Hex Head, 450°F
MS 27577	Bolts, Self-Retaining, Impedance-Type, 95 ksi $F_{su}$ , Flush Head, 450°F
MS 33540	Safety Wiring and Cotter Pinning, General Practices For
MS 33602	Bolts, Self-Retaining, Aircraft Reliability and Maintainability, Design and Usage Requirement For

3. Design and usage limitations. Fasteners in the category established by this requirement shall be subject to the following design and usage limitations.

- (a) Washer selected to take up excess bolt grip length and build up in clearance due to tolerances.
- (b) A bridging spacer or a castellated nut with a counterbore or recess for the retaining element may be used (3.2.5).

MIL-STD- 1599

REQUIREMENT 604

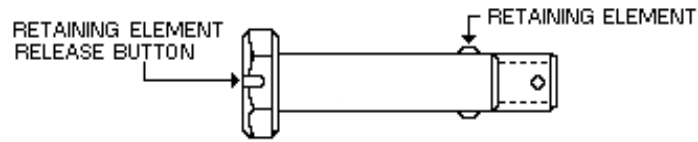


FIGURE 604-1. Positive-locking bolts.

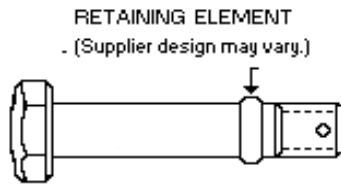


FIGURE 604-2. Impedance-type bolts.

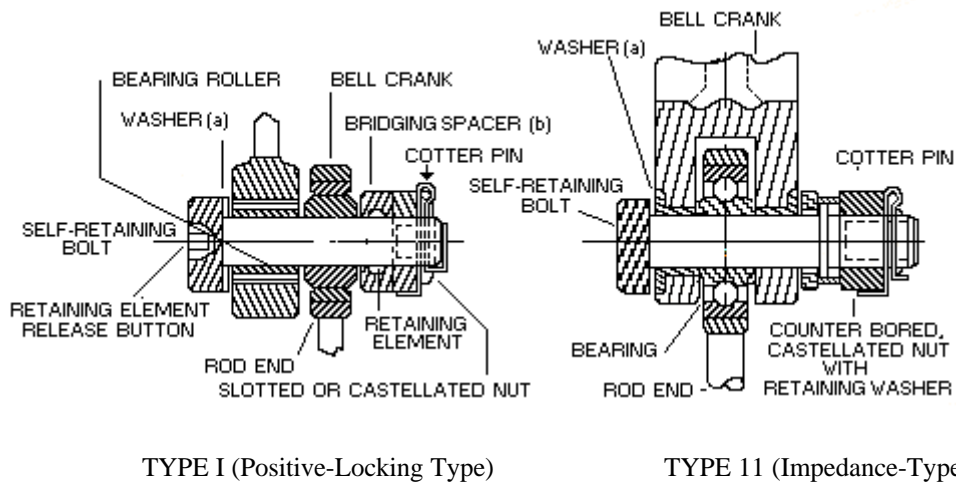


FIGURE 604-3. Example Joints.

3.1 Joint design. The joint shall be designed so that with a self-retaining bolt installed, the joint integrity is not dependent on washers or any other normally removable parts, other than bolts. Maximum of two washers may be used to adjust for tolerance variation and, when required, they shall be used under the head of the bolt, but not under the nut. Bridging spacers may be used on positive-locking bolts only. (Figure 604-3).

3.2 Usage. Self-retaining bolts shall be of any approved type and shall be used in accordance with the following design and usage requirements.

MIL-HDBK-1599A

REQUIREMENT 604

3.2.1 Self-retaining bolts shall be used in control system where the bolt serves as an axis of rotation and where separation of the linkage will affect safety of flight. These include controls for flight, fuel, engine air induction, and propeller system.

3.2.2 The bolts shall be additionally locked in position by nonself-locking or self-locking castellated nuts properly secured by cotter pins in accordance with MS 33540.

3.2.3 When self-retained bolts that are not identified by an MS part number are used, the retaining element and its locking device shall be a design used on bolts that have qualification approval to MIL-B-23964 for positive locking bolts or MIL-B-83050 for impedance-type bolts.

3.2.4 Self-retaining bolts that have had the retaining element or locking device reworked or reprocessed shall not be used.

3.2.5 Bridging spacers shall not be used with impedance-type bolts (Type II). Bridging spacers used with Type I positive-locking bolts shall be selected from MS 21126 or MS 21128.

3.2.6 Counterbored Castellated nuts with captive washers shall be selected from MS 14146, MS 21224, or MS 21244.

3.2.7 Impedance-type bolts (Type II) shall not be used in control systems of Navy aircraft.

3.3 Preferred parts. Corrosion-resistant steel parts are preferred over alloy steel parts.

4. Design selection and approved callout. Fasteners in the category established by this requirement shall be selected from and specified by standard part numbers in documents listed in section 2 of this requirement.

5. Intended use and guidance criteria. Table 604-I is presented as an aid in the selection of self-retaining bolts.

Table 604-I. Selection of self-retaining bolts.

Head Style	Drawing Number	Procurement Specifications	Material	Temperature Limit	Finish	Bolt Types
Hex	MS3369	MIL-B-23964	CRES	450°F	Passivated	Positive Locking
Pan	MS21125	MIL-B-23964	CRES	450°F	Passivated	Positive Locking
Flush	MS21130	MIL-B-23964	CRES	450°F	Passivated	Positive Locking
Hex	MS27476	MIL-B-83050	CRES, STEEL	450°F	Passivated Cadmium Plated	Impedance Type
Flush	MS27577	MIL-B-83050	CRES, STEEL	450°F	Passivated Cadmium Plated	Impedance Type

MIL-HDBK-1599A

REQUIREMENT 605

ENVIRONMENTAL PRESSURE SEALS

1. Scope. This requirement provides design guidance for the application of approved air pressure seals to be used with aircraft control cables that pass through barriers separating pressurized and nonpressurized areas. While not inclusive, this requirement presents baseline considerations from which designers can successfully develop flight control cable systems that result in minimal pressurization loss.

2. Applicable Documents.

MIL- G-23827	Grease, General Purpose
NASP 1350	Grommet, Nonmetallic
NASP 1351	Ring, Retaining

3. Construction.

3.1 Grommet. The grommet shall be a molded construction using the material and color specified in NASP1350.

3.2 Retaining Ring. The retaining ring shall be constructed using the material and finish specified in NASP 1351.

4. Usage.

4.1 Wire Rope Cables. Control cable sealing grommets and retaining rings are suitable for use on 3/32, 2/8, 5/32 and 3/16 diameter cables.

4.2 Lockclad Cables. Control cable sealing grommets and retaining rings are suitable for 0.169 and 0.201 diameter lockclad cables.

5. General Installation.

5.1 Grommet and cable section shall be lubricated with MIL-G-23827 grease.

5.2 Install from nonpressurized side of bulkhead.

5.3 with the small end of the grommet pointing toward the installation hole, insert cable into grommet slit.

5.4 Insert grommet into installation hole until fully seated.

5.5 Install two small and one large retaining clips as shown in NASP 1530.

6. Cable Alignment.

6.1 Angular. Angular misalignment of the cable axis, with respect to the centerline of the grommet, must not exceed 2.5 degrees.

6.2 Lateral. Lateral misalignment of the cable and the center of the bulkhead installation hole must not exceed 0.1 inch.

MIL-STD-1599A

REQUIREMENT 701

BEARING SHAFT BOLTS

1. Scope. This requirement establishes the criteria for the selection of bolts used as bearing shafts, other than dual safetying bolts (Requirement 604). It also establishes design guidance for special design bearing shaft bolts.

2. Applicable Documents.

MIL-STD-1515 Fastener Systems for Aerospace Applications

3. General.

3.1 Standard bolts. Standard bolts shall be selected in accordance with MIL-STD-1515.

3.2 Dual safetying bolts. Dual safetying bolts shall be selected in accordance with Requirement 604.

4. Design considerations. When bolts are used in conjunction with bearings, the following design criteria shall be considered.

4.1 Thread selections shall be in accordance with Requirement 108.

4.2 Bolts, studs, or screws shall extend through the self-locking nut for a length equivalent of 2 thread pitches. This length includes the chamfer.

4.3 Cadmium plated bolts shall not be used in contact with titanium or in applications where the operating temperatures exceed 450°F.

4.4 Silver plated bolts shall not be used in contact with titanium in applications where the operating temperatures exceed 600°F.

4.5 Silver plated bolts shall not be used with silver plated self-locking nuts.

4.6 Where possible and practicable, mating parts (except where flush head bolts are used) shall have similar external wrenching configurations.

4.7 Cadmium plated bolts shall not be used in space vehicle applications.

4.8 Wear life of TFE liners is highly dependent on the hardness and surface finish of the mating part. In applications where a bolt is used as the shaft in journal bearings or bore line spherical, optimum performance is obtained if the shank is honed, polished, or similarly finished after grinding. Recommended surface finish is RHR 18 maximum.

4.9 Wear life of TFE lined bearings is also dependent on the hardness and galling characteristics of the mating material. PH13-8Mo and chrome plated steel are suitable materials for use against TFE. Cadmium plated steel and bare titanium are not suitable materials for use against TFE. Contact the bearing suppliers concerning other materials and finishes.

MIL-STD-1599A

REQUIREMENT 701

4.10 Sharp edges or burrs on a part mating with TFE lined journal bearings may shave or cut the liner during installation, reducing its wear life. Special care shall be exercised to insure selected bolts have threads that are adequately truncated and lead in has smoothly blended or radiused corners.

4.11 Where nuts and bearing shaft bolts are used with anti-friction track rollers and needle bearings having retention end washers, the mounting faces of these components shall be held to a maximum of 0.001 inch flatness and 0.001 inch flatness with bolt shank or nut thread. Excessive concavity or out of squareness of these surfaces can cause bearing look up at assembly.

MIL-HDBK-1599A

REQUIREMENT 702

NUTS

1. Scope. This requirement establishes the approved nuts used with bearing shaft bolts other than safetying and jam nuts specified in Requirement 402. It also establishes design requirements for special design nuts used with bearing shaft bolts including materials, finishes, tolerances, threads, and radii.

2. Applicable Documents.

AN310	Nut, Plain, Castellated, Airframe
AN315	Nut, Plain, Airframe
AN316	Nut, Jam, Hexagon
AN320	Nut, Plain, Castellated, Shear
MS14144	Nut, Self-Locking, Lightweight, Castellated, 450°F
MS14145	Nut, Self-Locking, Lightweight, Thin Castellated, 450°F
MS14146	Nut, Self-Locking, Castellated, Hexagon, Counterbored, Captive Washer, 450°F
MS17825	Nut, Self-Locking, Castellated, Hexagon, 250°F Non-Metallic Insert
MS17826	Nut, Self-Locking, Castellated, Hexagon, 250°F, Thin Non-Metallic Insert
MS21224	Nut, Self-Locking, Castellated, Hexagon, Counterbored, Assembled washer, 250°F, Non-Metallic Insert (For Self-Retaining Bolts)
MS21244	Nut, Castellated, Hexagon, Counterbored

3. Design and usage limitations. Fasteners in the category established by this requirement shall be subject to the following design and usage limitations.

3.1 Thread selection shall be in accordance with Requirement 108.

3.2 Where nuts and bearing shaft bolts are used with anti-friction track rollers and needle bearings having retention end washers, the mounting faces of these components shall be held to a maximum of 0.001 inch flatness and 0.001 inch squareness with bolt shank or nut thread. Excessive concavity or out of squareness of these surfaces can cause bearing lock-up at assembly.

3.3 Bolts, studs, or screws shall extend through the self-locking nut for a length equivalent of 2 threaded pitches. This length includes the chamfer.

3.4 Self-locking nuts that have been reworked or reprocessed shall not be used.

3.5 Cadmium plated self-locking nuts shall not be used in contact with titanium and titanium alloy bolts, screws or studs or in applications where the operating temperatures exceed 450°F.

MIL-HDBK-1599A

REQUIREMENT 702

3.6 Silver plated self-locking nuts shall not be used in contact with titanium and titanium alloy bolts, screws or studs or in applications where the operating temperatures exceed 600°F.

3.7 Silver plated self-locking nuts shall not be used with silver plated bolts.

4. Design selection and approved callout. Fasteners in the category established by this requirement shall be selected from and specified by applicable documents listed in this requirement.

5. General criteria notes

5.1 Ultimate stress classification. The ultimate stress classification (ksi) of nuts listed in Table 702-I corresponds with the ultimate strength level of the mating externally threaded fastener. The ultimate stress classification of nuts listed is a guide, and generally obtained when tested with bolts having a minimum tensile strength greater than the rated tensile values and details.

5.2 Mating Parts. Where possible and practicable, mating parts (except where flush head bolts are used) shall have similar external wrenching configurations.

5.3 Space applications. Cadmium-plated nuts shall not be used in space vehicle components or systems. Nuts that are lubricated with dry film lubricants may be used in space applications provided the lubricant has been approved as meeting the outgassing requirements.

MIL-HDBK-1599A

REQUIREMENT 901

## UNIVERSAL JOINTS

1. Scope. This requirement establishes the approved universal joints for use in aerospace vehicle applications.

2. Applicable Documents.

MIL-U-3963	Universal Joint, Anti-Friction Bearings
MIL-J-6193	Joints, Universal, Plain, Light and Heavy Duty
MS 20270	Joint Universal, Plain, Light Duty
MS 20271	Joint Universal, Plain, Heavy Duty
MS 24312	Universal Joint, Anti-Friction Bearing, Round Hub

3. Design requirements. Universal joints shall conform to the requirement of MIL-U-3963, MIL-J-6193, MS 20270, MS 20271, and MS 24312.

## STANDARDIZATION DOCUMENT IMPROVEMENT PROPOSAL

### INSTRUCTIONS

1. The preparing activity must complete blocks 1, 2, 3, and 8. In block 1, both the document number and revision letter should be given.
2. The submitter of this form must complete blocks 4, 5, 6, and 7.
3. The preparing activity must provide a reply within 30 days from receipt of the form.  
 NOTE: This form may not be used to request copies of documents, nor to request waivers, or clarification of requirements on current contracts. Comments submitted on this form do not constitute or imply authorization to waive any portion of the referenced document(s) or to amend contractual requirements.

**I RECOMMEND A CHANGE:**

1. DOCUMENT NUMBER  
MIL-HDBK-1599A

2. DOCUMENT DATE (YYMMDD)  
97/10/02

3. DOCUMENT TITLE

BEARINGS, CONTROL SYSTEM COMPONENTS, AND ASSOCIATED HARDWARE USED IN THE DESIGN AND CONS

4. NATURE OF CHANGE *(Identify paragraph number and include proposed rewrite, if possible. Attach extra sheets as needed.)*

5. REASON FOR RECOMMENDATION

**6. SUBMITTER**

a. NAME *(Last, First, Middle Initial)*

b. ORGANIZATION

c. ADDRESS *(include Zip Code)*

d. TELEPHONE *(Include Area Code)*

e. DATE SUBMITTED  
(YYMMDD)

(1) Commercial

(2) AUTOVON  
*(If applicable)*

**8. PREPARING ACTIVITY**

a. NAME

WR-ALC/LKJE

b. TELEPHONE *(Include Area Code)*

(1) Commercial

(912) 926-2864

(2) AUTOVON

468-2864

c. ADDRESS *(Include Zip Code)*

460 SECOND STREET, STE 221  
ROBBINS AFB, GA 31098-1640

**IF YOU DO NOT RECEIVE A REPLY WITHIN 45 DAYS, CONTACT:**

Defense Quality and Standardization Office  
5203 Leesburg Pike, Suite 1403, Falls Church, VA 22041-3466  
Telephone (703) 756-2340 AUTOVON 289-2340