

NOT
MEASUREMENT
SENSITIVE

MIL-HDBK-1512 (USAF)
30 September 1997

NOTE: Mil-Std-1512 has been redesignated as a Handbook, and is to be used for guidance purposes only. For administrative expediency, the only physical change from Mil-Std-1512 is this cover page. However, this document is no longer to be cited as a requirement. If cited as a requirement, Contractors may disregard the requirement of this document and Interpret its contents only as guidance.

DEPARTMENT OF DEFENSE HANDBOOK

ELECTROEXPLOSIVE SUBSYSTEMS, ELECTRICALLY INITIATED, DESIGN REQUIREMENTS AND TEST METHODS



AMSC N/A

AREA EMCS

DISTRIBUTION STATEMENT A. Approved for public release; distribution is unlimited.

MIL-STD-1512 (USAF)
21 March 1972

DEPARTMENT OF THE AIR FORCE

Electroexplosive Subsystems, Electrically Initiated,
Design Requirements and Test Methods

MIL-STD-1512 (USAF)

1. This Military standard has been approved by the Department of the Air Force and is mandatory for use, effective on date of issue, by that activity.
2. Recommended changes, additions, or deletions should be addressed to the 4950th Test Wing (4950/TZSS), Wright-Patterson Air Force Base, Ohio 45433.

FOREWORD

This standard establishes the general requirements and test methods for the design and development of electroexplosive subsystems and associated items to preclude hazards from unintentional initiation. These requirements apply to all subsystems utilizing electrically initiated, explosive, or pyrotechnic components.

MIL-STD-1512 (USAF)
21 March 1972

CONTENTS

	<u>Page</u>
1. SCOPE	1
1.1 Purpose	1
1.2 Test methods	1
1.2.1 Revision of test methods	1
1.2.2 Tentative test methods	1
1.3 Application	1
1.3.1 Implementation	1
1.3.2 Extent of applicability	1
1.4 Minimum requirements	2
2. REFERENCED DOCUMENTS	2
3. DEFINITIONS	4
3.1 Terms used	4
3.1.1 Arm and disarm (A/D)	4
3.1.2 Bridgewire	4
3.1.3 Dudding	4
3.1.4 Electroexplosive device	4
3.1.5 Electroexplosive initiator	4
3.1.6 Electroexplosive subsystem (EES)	4
3.1.7 Electromagnetic environment	4
3.1.8 Electromagnetic susceptibility threshold	4
3.1.9 Exploding bridgewire (EBW) initiator	4
3.1.10 Maximum no-fire current	5
3.1.11 Minimum all-fire current	5
3.1.12 Safe and arm (S&A) device	5
3.1.13 Statistical test procedures	5
4. GENERAL REQUIREMENTS	5
4.1 General design	5
4.2 Safety criteria	6
4.2.1 Safety device	6
4.2.2 Safe and arm device	6
4.2.3 Arm-disarm devices	6
4.2.4 EBW safety	6
4.3 Human factors	6
4.4 Nonstandard parts	6
4.5 Bonding and grounding	6
4.6 Electroexplosive subsystems design criteria	7
4.6.1 Firing levels	7
4.6.2 Electromagnetic compatibility	7
4.6.3 Service life	7

CONTENTS (CONT)

	<u>Page</u>	
4.6.4	Lightning strike survivability	7
4.6.5	Dissimilar metals	7
4.6.6	Components	7
4.6.7	Reliability	7
4.6.8	Fungus inert materials	7
4.6.9	Nonreactive materials	8
4.6.9.1	Nonmetallic parts	8
4.6.9.1.1	Storage	8
4.6.9.1.2	Compatability	8
4.6.9.1.3	Outgassing	8
4.6.9.2	Metallic parts	8
4.6.9.2.1	Corrosion protection	8
4.6.9.2.2	Finishes	8
4.6.9.2.3	Electrical bonding	8
4.6.9.2.4	Chemical film treatments	8
4.6.10	Reactive materials	
5.	DETAIL DESIGN CRITERIA	9
5.1	Electrical requirements	9
5.2	Power supply	9
5.3	Wiring	9
5.4	Circuit categorization	9
5.5	Shields	9
5.6	Shielding caps	10
5.7	Cables	10
5.8	Insulation resistance	10
5.9	Post firing short circuit protection	10
5.10	Firing circuits	11
5.10.1	Wiring	11
5.10.2	Isolation	11
5.10.3	Mechanical isolation	11
5.10.4	Electrostatic protection and isolation	11
5.10.5	Simulator resistors	11
5.10.6	Current flow	11
5.10.7	Monitor circuits	12
5.11	Connectors	12
5.11.1	Type	12
5.11.2	Pin assignments	12
5.11.3	Locking	12
5.12	Switches	12
5.12.1	Electromechanical	12
5.12.2	Solid-state	13

MIL-STD-1512 (USAF)
 21 March 1972

CONTENTS (CONT)

	<u>Page</u>
5.13	Mechanical requirements 13
5.13.1	Structural 13
5.13.2	Mounting 13
5.13.3	Mechanical integrity 13
5.14	Electroexplosive initiators (EELs) electrical design requirements 13
5.14.1	No-fire sensitivity 13
5.14.2	Carbon bridgewires 13
5.14.3	Conductive mixes 13
5.14.4	EBW 13
5.15	S&A and A/D devices 14
5.15.1	Electrically actuated 14
5.15.1.1	Cyclic life 14
5.15.1.2	RF susceptibility 14
5.15.1.3	Stall-arming characteristics 14
5.15.1.4	Electrical arming and safing time 14
5.15.2	Mechanical actuation 14
5.15.2.1	Safety provisions 15
5.15.2.2	Safing pin 15
5.15.2.3	Streamer (Safing pins) 15
5.15.2.4	Safe indication 15
5.16	Environmental requirements 16
5.17	Transportation and handling 16
5.17.1	Elevated temperatures 16
5.17.2	Electromagnetic 16
5.18	Hermetic sealing 16
5.19	Data 16
6.	QUALITY ASSURANCE PROVISIONS 17
6.1	Applicable tests 17
6.2	Responsibility for inspection 17
6.3	Test sequences 17
6.4	Classification of inspections 17
6.5	Hazard classification tests 17
6.6	Safety reliability demonstrations 17
6.7	Qualification inspections and tests 17
6.7.1	Requalification testing 20
6.8	Lot acceptance sampling inspections and tests 20
6.8.1	Electroexplosive initiators 20
6.8.2	S&A and A/D devices 21
6.8.3	Electroexplosive subsystem 21
6.8.4	Lot acceptance sampling size 22

CONTENTS (CONT)

		<u>Page</u>
6.9	Induced energy monitors	22
6.10	Deliverable data	23
6.11	Publications	23
6.12	Tailoring of requirements and limits	23
6.13	Documentation	23
6.13.1	Management and design review documentation	23
6.13.1.1	Plan	23
6.13.1.2	Design documentation	24
6.13.1.3	Test/analysis documentation	24
6.13.1.4	Qualification plan	24
6.13.1.5	Qualification report	25
6.13.1.6	Acceptance documentation	26
6.13.1.7	Specialized documentation	26
6.13.1.8	Qualification requirements	26
6.13.1.9	Conditions for testing	26
6.13.1.9.1	Test equipment	26
6.13.1.9.2	Environment	27
7.	NOTES	27
8.	TEST METHODS	27

TABLES

I	Electroexplosive Initiators Qualification Tests - Test Sequence	18
II	Safe & Arming Device - Qualification Test	19
III	Electroexplosive Subsystems - Test Sequence	20

MIL-STD-1512 (USAF)
21 March 1972

CONTENTS (CONT)

		<u>Page</u>
METHODS		
101	Visual inspection	101-1
102	Dimensional	102-1
103	Radiographic	103-1
104	Temperature and humidity	104-1
105	Temperature - altitude	105-1
106	Thermal shock	106-1
107	Moisture resistance	107-1
108	Salt spray	108-1
109	Fungus	109-1
110	Space simulation	110-1
111	Seal effectiveness	111-1
112	Steady-state acceleration	112-1
113	Vibration	113-1
114	Shock	114-1
115	Acoustical noise	115-1
116	Terminal strength	116-1
117	Insulation resistance	117-1
118	Shelf life (environmental conditions)	118-1
119	Transportation vibration	119-1
201	Bridgewire resistance	201-1
202	Maximum energy dissipation	202-1
203	DC sensitivity characteristics	203-1
204	Radio frequency impedance	204-1
	Figure 204-1 Typical RF Impedance Measurement	204-1
205	Static discharge sensitivity	205-1
206	Thermal time constant	206-1
207	Radio frequency sensitivity	207-1
208	DC susceptibility	208-1
209	Dent test	209-1
301	Explosion	301-1
302	Lightning strike induced energy	302-1
303	Electromagnetic analyses of the electroexplosive subsystem	303-1

1. SCOPE

1.1 Purpose. The purpose of this document is to establish uniform design and qualification requirements and test methods for the design, development, and acceptance of all electroexplosive subsystems and component parts.

1.2 Test methods. The test methods described herein have been prepared to:

a. Specify conditions obtainable in the laboratory which give test results similar to actual effects due to conditions existing under operational environments and to obtain reproducibility of test results

b. Describe in a single military standard all test methods for electro-explosive subsystems and components to maximize the conservation of equipment, man-hours, and testing facilities and comparability of test results.

1.2.1 Revision of test methods. Revisions of each test method shall be indicated by a revision letter following the method number. For example, the first revision of test method 101 would be 101A, the second revision would be 101B, et cetera. When referencing test methods, do not indicate the revision letter.

1.2.2 Tentative test methods. Proposed new test methods will be used as tentative test methods prior to formal coordination. A tentative test method can be submitted to the procuring activity for evaluation by any organization using this standard. Tentative test methods shall be identified by a capital T preceding the method number. The use of tentative test methods provides a means of keeping all applicable methods in one standard, provides a ready reference for users without copying methods in specifications, and permits trial use of new or modified tests without affecting the status of standard methods.

1.3 Application. This standard will be used during the entire system life cycle.

1.3.1 Implementation. This standard shall be used to prepare requirements for inclusion in contract work statements, program plans, test plans, and other contractual documents. Such requirements will be prepared by the procuring activity and imposed on the contractor for implementation. The contractor shall similarly impose all requirements on his subcontractors, suppliers, and vendors to the extent of applicability.

1.3.2 Extent of applicability. Each provision of this standard shall be considered as applicable to each ordnance component, subsystem, and system

MIL-STD-1512 (USAF)
21 March 1972

Requests for deviation, waiver, or supplementary requirements shall be individually submitted to the procuring activity for approval. Where a requirement of this standard would necessitate duplication wholly or in part, of valid design, analysis, test, or other such valid activity already specified by the procuring activity those requirements, functions, and efforts shall be identified and utilized in demonstrating compliance with the respective requirements specified herein. Duplication is not required.

1.4 Minimum requirements. When the scope and magnitude of a program does not warrant imposition of all the requirements specified herein, the procuring activity will specify to the contractor the minimum acceptable program requirements.

2. REFERENCED DOCUMENTS

2.1 The issues of the following documents in effect on the date of invitation for bids form a part of this standard to the extent specified herein:

SPECIFICATIONS

Military

MIL-B-5087	Bonding, Electrical, and Lighting Protection, For Aerospace Systems
MIL-E-5400	Electronic Equipment, Airborne, General Specification for
MIL-E-6051	Electromagnetic Compatibility Requirements, Systems
MIL-E-8189	Electronic Equipment, Missiles, Boosters and Allied Vehicles
MIL-E-8983	Electronic Equipment, Aerospace, Extended Space Environment, General Specification for
MIL-I-23659	Initiator, Electric, Design and Evaluation of

STANDARDS

Federal

FED-STD-595	Colors
-------------	--------

Military

MIL-STD-171	Finishing of Metal and Wood Surfaces
MIL-STD-186	Protective Finishing Systems for Rockets, Guided Missiles, Support Equipment and Related Materials
MIL-STD-202	Test Methods for Electronic and Electrical Component Parts
MIL-STD-331	Fuze and Fuze Components, Environmental and Performance Tests for

MIL-STD-1512 (USAF)
21 March 1972

MIL-STD-453 Inspection, Radiographic
MIL-STD-454 Standard General Requirements for Electronic Equipment
MIL-STD-461 Electromagnetic Interference Characteristics Requirements
for Equipment
MIL-STD-681 Identification Coding and Application of Hookup and Lead Wire
MIL-STD-709 Ammunition Color Coding
MIL-STD-810 Environmental Test Methods
MIL-STD-863 Wiring Data, Preparation of
MIL-STD-882 System Safety Program for Systems and Associated Subsystems
and Equipment, Requirements for
MIL-STD-1472 Human Engineering Design Criteria for Military Systems,
Equipment and Facilities
MS51700 Streamer, Warning

PUBLICATIONS

Data List

TD-3 DOD Authorized Data List

Naval Ordnance Lab Technical Rpt

63-133 The Prediction of Very Low EED Firing Probabilities
(Sept A63, .
Lad 426 466)

AFSC Design Handbooks

DH 1-4 Electromagnetic Compatibility
DH 1-6 System Safety
DH 2-5 Armament

Inspection and Quality Control Handbook

H 106 Multi-level Continuous Sampling Procedures and Tables for
Inspection by Attributes

(Copies of specifications, standards, drawings, and publications required by
suppliers in connection with specific procurement functions should be obtained
from the procuring activity or as directed by the contracting officer.)

MIL-STD-1512 (USAF)
21 March 1972

3. DEFINITIONS

3.1 Terms used. The following are definitions of terms as used in this standard:

3.1.1 Arm and disarm (A/D). Arm and disarm (A/D) is defined as a mechanical or electromechanical device that provides a positive interruption of the firing circuit to prevent initiation of an explosive or pyrotechnic train prior to its commanded closure.

3.1.2 Bridgewire. Bridgewire is defined as a resistance element within the electroexplosive initiator which is the final electrical element at the electrical/explosive (or pyrotechnic) interface.

3.1.3 Dudding. Dudding means the process of permanently degrading an electroexplosive initiator to a state where it cannot perform its designed function.

3.1.4 Electroexplosive device. Electroexplosive device is defined as any electrically initiated explosive device within an electroexplosive subsystem having an explosive or pyrotechnic output, and actuated by an electroexplosive initiator.

3.1.5 Electroexplosive initiator. The electroexplosive initiator is the first device in a pyrotechnic or explosive train which is designed to transform an electrical, mechanical, or heat input into an explosive or pyrotechnic reaction. Detonators, electrical match, and squibs are examples of initiators.

3.1.6 Electroexplosive subsystem. The term electroexplosive subsystem is intended to include all components required to perform control, monitor, and initiation of an electrical initiated ordnance/pyrotechnic function.

3.1.7 Electromagnetic environment. Electromagnetic environment is defined as the totality of all electromagnetic energy (radiated and conducted) to which the electroexplosive subsystem will be subjected during its life cycle.

3.1.8 Electromagnetic susceptibility threshold. Electromagnetic susceptibility threshold is defined as the magnitude of the smallest electric field expressed in volts/meter or amperes/meter capable of producing a current 20 dB below the maximum DC or RF no-fire current.

3.1.9 Exploding bridgewire initiator. An exploding bridgewire initiator is defined as a type of electroexplosive initiator in which the bridgewire is designed to be exploded (disintegrated) by a high-energy electrical discharge, thus requiring no primary explosives.

3.1.10 Maximum no-fire current. Maximum no-fire current is defined as the maximum DC or RF current level at which an electroexplosive initiator will not fire or degrade with a reliability of .995 at a confidence level of 95 percent.

3.1.10.1 The definition specified in 3.1.10 makes it incumbent upon the procuring activity and the manufacturers to verify the reliability and confidence level by suitable statistical test methods (see MIL-I-23659). For example, a sample size of 650 devices is required to verify a reliability of .995 at a confidence level of 95 percent under ideal conditions where the maximum no-fire current level has been previously determined, and all samples as tried at this stimulus level with all no-fires. While the Brucceton test method gives a very good estimate of the mean (50 percent) firing current, it tends to give a poor estimate of the standard deviation; an essential parameter for extrapolation to determine no-fire- and all-fire currents. (See Naval Ordnance Laboratory Technical Report 63-133, The Prediction of Very Low EED Firing Probabilities, Sept A63 Lad 426 466, and MIL-I-23659.)

3.1.11 Minimum all-fire current. Minimum all-fire current is defined as the least DC or RF firing current which causes initiation with a reliability of .995 at a confidence level of 95 percent.

3.1.11.1 Similar precautions as recommended in 3.1.10.1 shall be followed.

3.1.12 Safe and arm (S&A) device. A safe and arm (S&A) device means a device which provides electrical interruption of the firing circuits and mechanical interruption between the initiator and the subsequent explosive or pyrotechnic train.

3.1.13 Statistical test methods. Brucceton, Probit, and Langley methods are statistical test methods often used and are described in MIL-I-23659.

4. GENERAL REQUIREMENTS

4.1 General design. Requirements peculiar to electroexplosive subsystems are covered in this standard. Those general requirements not peculiar to electroexplosive subsystems shall be in accordance with MIL-E-5400, MIL-E-8189, or MIL-E-8983 as specified by the procuring activity. An electroexplosive subsystem shall not be used when the functional requirement can be met by other equally cost effective means. Electroexplosive subsystems shall be designed to include safety features and proven operational reliability to preclude inadvertent firing or degradation of any explosive component in the explosive system, when subjected to the individual specification environmental requirements.

MIL-STD-1512 (USAF)
21 March 1972

4.2 Safety criteria. For all subsystems and components, the safety criteria for reduction of hazards through the system life cycle shall be in accordance with MIL-STD-882. The design of the subsystem shall be such that in the safed condition the intentional or accidental application of a single signal in any circuit will not of itself result in a system generating signals that will inadvertently initiate, arm, or activate any electroexplosive subsystem device. Sufficient fault isolation against an inadvertent signal shall be incorporated such that a minimum of two separate faults occurring in series will be required to cause inadvertent initiation of an electroexplosive device. Color coding of devices shall be in accordance with MIL-STD-709.

4.2.1 Safety device. An electromechanical safety device shall be utilized in each electroexplosive subsystem, except those utilizing exploding bridgewires, to provide electrical isolation between each initiator and the electrical source and to permit programmed checkout of the firing circuits.

4.2.2 Safe and arm device. A safe and arm device which provides mechanical and electrical isolation of the electrical initiator and primary explosive shall be used where inadvertent firing of an electroexplosive subsystem would result in a catastrophic event.

4.2.3 Arm-disarm devices. Arm-disarm devices shall be used on all electroexplosive subsystems other than those requiring safe and arm devices.

4.2.4 Exploding bridgewire safety. In exploding bridgewire subsystems, a safety device shall provide a positive interruption of the capacitor charging circuit and the trigger circuit. In addition, a provision capable of discharging the exploding bridgewire subsystem capacitor circuit shall be provided.

4.3 Human factors. The electroexplosive subsystem shall be designed to enhance functional performance and to minimize hazards to personnel involved in assembling, transporting, installing, removing, maintaining, and testing systems involving the use of electroexplosive initiators. MIL-STD-1472 shall be used for design criteria.

4.4 Nonstandard parts. The use of nonstandard parts shall be in accordance with requirement 22 of MIL-STD-454.

4.5 Bonding and grounding. Continuous vigilance shall be maintained to avoid inadvertent electrical grounds and other undesirable electrical paths between all electroexplosive subsystems and their associated grounds. Unless otherwise specified (see 7.1), all metallic parts of the electroexplosive subsystem shall be bonded in accordance with MIL-B-5087, class R.

4.6 Electroexplosive subsystems design criteria

4.6.1 Firing levels. Electroexplosive subsystem firing levels shall be designated by the procuring activity.

4.6.2 Electromagnetic compatibility. Subsystems using electroexplosive devices shall be designed, tested, packaged, handled, and stored to preclude spurious functioning of any system electroexplosive initiator or dudding of any electroexplosive initiator with respect to reliability or performance characteristics by environmental electromagnetic energy during the system life cycle. Unless otherwise specified in the contract or system EMC plan (see 7.1), safety margins less than 20 dB shall not be used. All electromagnetic interference control shall be in accordance with MIL-E-6051 and requirement 61 of MIL-STD-454. When this requirement is invoked at other than the subsystem level, the tailoring and analysis shall be included in the control plan (see 6.13.1.1).

4.6.3 Service life. Unless otherwise specified (see 7.1), the minimum service life shall be 10 years, including preinstallation storage. The materials selected and the design features shall be based on proven history of favorable storage and compatibility characteristics under environmental conditions similar to those to be experienced by the system. Where storage history is not available, laboratory material and component storage data, including accelerated storage, shall be extrapolated to demonstrate a minimum of 10 years storage life.

4.6.4 Lightning strike survivability. Since the system is required to survive lightning strikes, the electroexplosive subsystem shall be designed to be compatible with the induced energy.

4.6.5 Dissimilar metals. The use of dissimilar metals shall be in accordance with requirement 16 of MIL-STD-454.

4.6.6 Components. The quantity of individual components making up an electroexplosive subsystem shall be kept to an absolute minimum commensurate with sound engineering practices. Interconnectors, quick disconnects, electrical plugs, and all electrical connections shall be designed to preclude electrical malfunction. Wire, cable, and connector movement shall be restricted within design environmental requirements.

4.6.7 Reliability. The design reliability of the electroexplosive subsystem shall be .995 or the reliability figure apportioned from the next higher assembly, whichever is greater.

4.6.8 Fungus inert materials. Fungus inert materials shall be selected in accordance with requirement 4 of MIL-STD-454.

MIL-STD-1512 (USAF)

21 March 1972

4.6.9 Nonreactive materials

4.6.9.1 Nonmetallic parts. The selection and usage of nonmetallic parts shall be predicated on their ultimate functions, space limitation, weight, and environmental exposure. All such materials shall conform to the following:

4.6.9.1.1 Storage. Nonmetallic parts utilized in ordnance subsystems or components shall not degrade that subsystems or components ability to meet the storage requirement specified herein.

4.6.9.1.2 Compatibility. Nonmetallic parts in contact with each other or with reactive materials shall be compatible when subjected to the environmental conditions specified herein.

4.6.9.1.3 Outgassing. Materials that outgas when subjected to the environments specified herein shall not be used if the performance or safety of the system or any subsystem thereof is adversely affected.

4.6.9.2 Metallic parts

4.6.9.2.1 Corrosion protection. Metallic parts shall be protected from the deteriorating effects of climatic and electrolytic corrosion.

4.6.9.2.2 Finishes. The finishes for new and repaired parts, except for plating, shall be in accordance with MIL-STD-186. Plating finishes shall be in accordance with MIL-STD-171.

4.6.9.2.3 Electrical bonding. Where necessary to meet the requirements of low impedance bonding, bonding surfaces shall be free of all insulating finishes. Such surfaces shall be temporarily protected, and after bonding, the unprotected face shall be protected against corrosion prior to assembly.

4.6.9.2.4 Chemical film treatments. The design activity shall select the cleaning method and the treatment for each application and shall reference them on drawings and in item specifications by Military standard or specification number. Selected cleaning and treatment methods shall meet the requirements of MIL-STD-171.

4.6.10 Reactive materials. The selection and usage of all reactive materials including detonable, deflagratable, pyrogen, and propellant substances shall be predicated on ultimate function, space limitation, weight, and environmental exposure; and shall conform to the following requirements:

a. Reactive materials in contact within any electroexplosive initiator shall be compatible with each other and with the nonreactive components they contact

so that in continued exposure to the environmental conditions specified herein, there shall be no degradation in performance.

b. Reactive components, including electroexplosive initiators and sequential high-explosive components, shall be designed to permit determination of performance.

c. Identification of the chemical composition of all reactive materials shall be provided to the procuring activity.

5. DETAIL DESIGN CRITERIA

5.1 Electrical requirements. Electroexplosive subsystems and their components shall be designed to prevent inadvertent arming, actuation, or initiation due to operator error, short circuit, or other failure modes.

5.2 Power supply. A separate power supply shall be used for the electro-explosive subsystem which shall be isolated from all other electrically powered subsystems. Power supplies using radio frequency energy for initiation of explosives are prohibited.

5.3 Wiring. All electroexplosive subsystem circuits shall use twisted, shielded pair wires. The return side of the circuit shall be grounded only at the power supply. These shall be clearly and specifically discernible from other electrical circuits by color coding in accordance with MIL-STD-681 and identified in accordance with MIL-STD-863. In addition, all firing circuit wires contained within junction boxes shall be isolated from other circuits and shall be identified with a red stripe conforming to color No. 11105 of FED-STD-595. All firing circuit leads and junctions shall be shielded without discontinuities to provide a minimum of 40 dB attenuation. The source circuits shall terminate in a connector with female contacts.

5.4 Circuit categorization. All electroexplosive subsystem wiring and circuits shall be categorized in accordance with their functions and current levels. Current levels within a factor of 3 may be considered as one category.

5.5 Shields. Firing circuit shielding shall provide a minimum of 40 dB attenuation from 30 KHz to 40 GHz. There shall be no gaps or discontinuities in the shielding, including the termination at the back faces of the connectors. Individual circuit shields contained within an overall shielded cable may be terminated by means of pigtailed not exceeding 1 inch in length, with prior approval of the procuring activity. Electrical continuity and isolation of electroexplosive subsystem circuitry shields shall be maintained.

MIL-STD-1512 (USAF)
21 March 1972

If the electroexplosive initiator is enclosed in a metal container which provides attenuation equal to or greater than the shield, the shield may be terminated at the container connector when the connector can provide RF attenuation equal to or greater than the shield, and the shield is electrically bonded around the circumference of the connector. Shields shall not be used as intentional current-carrying conductors.

5.6 Shielding caps. All electroexplosive initiators, safe and arm devices, and arm and disarm devices shall have shielding caps attached during handling, transporting, maintaining, and installation. These shielding caps shall meet the following requirements:

- a. The outer shells shall be made of metallic material
- b. The outer shells shall make electrical contact with the case of the electroexplosive initiator
- c. There shall be no gaps between the shielding cap and the case of the electroexplosive initiator
- d. When removed, the cap shall leave the bridgewire pins unshorted.

5.7 Cables. Electrical cables may be fabricated such that several electroexplosive subsystem circuits are contained in a common shielded cable bundle. There shall be no splices within cable bundles nor shall splicing be used to join elements of ordnance circuitry where mating-demating may take place. Wherever mating or demating of a circuit is required, a connector shall be provided. All cable runs shall be routed as close to metal structure as feasible.

5.8 Insulation resistance. All current-carrying components and conductors shall be electrically insulated from each other and system ground. The insulation resistance between all insulated parts, at a potential of 500V, minimum, dc, shall be greater than 100 megohms after exposure to the environment specified herein.

5.9 Post firing short circuit protection. Electroexplosive subsystem circuitry shall include positive protection for line-to-line and line-to-ground shorts which may develop within a fired electroexplosive initiator. Two hundred milliseconds after firing, the leakage current shall not exceed 0.05 ampere when normal voltage is applied between the bridgewire circuit(s) or between each pin and the electroexplosive initiator case. Where current-limiting resistors are employed, burning out of the resistor(s) shall not be relied upon for protection.

5.10 Firing circuits

5.10.1 Wiring. A firing circuit shall have its return grounded only at the power source.

5.10.2 Isolation. Firing circuits shall be isolated by at least 50 dB from other circuits and each other by individual shields before, during, and after installation of the electroexplosive initiators and control mechanisms. If a circuit must be grounded, there shall be only one connection to ground.

5.10.3 Mechanical isolation. All firing circuits shall be physically isolated from any power, control checkout, monitor, continuity, and other nonsimultaneous firing circuits and shall use a separate and nonsimultaneous firing circuit and a separate and noninterchangeable electrical connector. If this is not practicable, firing circuits may be included in the same cable harness and same connector provided that the safety, reliability, and isolation criteria as specified herein are not compromised. Firing circuits shall be isolated from the electroexplosive initiator case and other parts of the structure.

5.10.4 Electrostatic protection and isolation. In the safe condition, no electrical continuity shall exist between the firing source either on its plus or common return lines and the firing output connector (A/D) or electrical initiators (S&A). In addition, in the safe condition, the output firing lines to the electroexplosive device(s) shall be shorted and the short grounded through a 10,000- to 500,000-ohm resistor. In the armed condition, the electroexplosive device firing circuit shall be completed, and the short removed; the resistor shall not be removed.

5.10.5 Simulator resistors. Safety devices may contain a simulator resistor across each of the firing line circuits to permit testing of the firing circuit without energizing the electrical initiators. The application of operational voltages to the resistor for a duration of 20 seconds, minimum, shall not cause degradation in performance of the device. Also, application of operational voltage for times in excess of 20 seconds shall not create a hazardous condition. However, an intentional failure mode may be incorporated in the device to satisfy the over-20-second requirement providing the failure does not compromise safety. Arming of the device shall remove the simulator resistor from the circuit. Proper current-limiting devices shall be incorporated within the device to limit the inductive voltage caused by collapsing fields.

5.10.6 Current flow. There shall be no current flow exceeding 2 milliamperes in the disarm or safe command circuit during the arming cycle nor in the arm command circuit during the disarm of safing.

MIL-STD-1512 (USAF)
21 March 1972

5.10.7 Monitor circuits. All circuits used to arm or disarm S&A or A/D devices shall contain a means to provide remote electrical indication of their armed or safe status. The electrical continuity of one status circuit shall completely break immediately prior to the time that the electrical continuity is established for the other status circuits. Continuity of the safe status circuit shall be established immediately after the firing circuits are opened and the output leads (A/D) or initiators leads (S&A) are shorted. During checkout, the safe or armed status circuits shall be capable of being monitored electrically by the AGE. The maximum current in any monitoring circuit shall be limited to one-tenth the no-fire current of the electro-explosive initiator. However, monitor circuits shall be designed such that application of operational voltage will not compromise the safety of the firing circuit nor cause the electroexplosive subsystem to be armed.

5.11 Connectors. Connectors used in the electroexplosive subsystem and on components such as S&A and A/D devices shall be compatible with the mating interface connectors. There shall be only one wire per connector pin.

5.11.1 Type. All electroexplosive subsystem connectors shall be stainless-steel shells. Anodized aluminum finishes shall not be used. Connectors shall be selected to eliminate the possibility of mismatching connectors.

5.11.2 Pin assignments. The circuit assignments and isolation of pins within a connector shall be such that any single short circuit occurring as a result of a bent pin will not result in more than 100 milliamperes current applied to any electroexplosive subsystem circuit. There shall be only one wire per pin, and in no case shall a connector pin be used as a terminal or tie-point for multiple connections.

5.11.3 Locking. Connectors shall be of the self-locking type. All connector shall be lockwired to prevent accidental or inadvertent demating.

5.12 Switches. The following requirements are applicable to switches used in firing circuits of the electroexplosive subsystems:

5.12.1 Electromechanical. The contacts of electromechanical switches shall satisfy the following:

a. Minimum continuous current rating equal to the amplitude of the firing current pulse, with no more than 100 millivolts drop between the contact terminals, after performing (c) and (d)

b. Maximum contact resistance, as measured by a 100-milliamper device, shall be less than 50 milliohms after performing (c) and (d)

c. With the contacts closed, apply one hundred applications of a current pulse of amplitude 10 times the rated current and duration of 250 milliseconds

d. Operate the switch through one hundred on-off cycles while breaking a current four times the rated current.

5.12.2 Solid-state. Solid-state switches shall be capable of delivering the maximum post-firing short circuit current for a time interval equal to ten times the duration of the firing pulse. These switches shall be capable of breaking the post-fire short circuit current without exceeding any steady-state or transient setups of the solid-state device used.

5.13 Mechanical requirements

5.13.1 Structural. All subsystem, component, and attachment fittings including connector shells shall be designed to meet the structural requirements and to withstand the applicable grounding and operational loads requirements.

5.13.2 Mounting. Unless otherwise specified (see 7.1), the electroexplosive initiator shall be capable of performing as specified when mounted in any position.

5.13.3 Mechanical integrity. Devices which are a part of a pressure vessel shall be designed to withstand the backpressure from the ignition of initiators and the subsequent ordnance trains, propellant, or explosives ignited by these initiators.

5.14 Electroexplosive initiators electrical design requirements

5.14.1 No-fire sensitivity. Unless otherwise specified (see 7.1), electroexplosive initiators shall be designed to withstand a firing pulse current of up to 1 ampere and 1 watt power (minimum) for a period of 5 minutes (minimum) duration without initiation or deterioration of performance (dudding).

5.14.2 Carbon bridgewires. Electroexplosive initiators using carbon bridgewires are prohibited.

5.14.3 Conductive mixes. Use of conductive mixes to meet the 1 amp/1 watt/5 minute requirement is not recommended and will be permitted only when the radio frequency susceptibility requirement is satisfied.

5.14.4 Exploding bridgewire. The exploding bridgewire is considerably less vulnerable in all situations (if its associated circuits are properly designed), and is recommended when a high degree of safety and reliability is required; when the necessary weight and space penalties are not overwhelming.

MIL-STD-1512 (USAF)
21 March 1972

5.15 S&A and A/D devices

5.15.1 Electrically actuated. These devices shall incorporate a means of remote electrical arming and disarming from any position. Remoted and manual disarming shall be accomplished without passing through the arm position. The devices shall not be capable of being manually armed, but shall be capable of being manually safed. The devices shall remain mechanically secured in the selected position under all operational environments without the application of any electrical signal.

5.15.1.1 Cyclic life. All electrically actuated electroexplosive subsystem devices shall withstand repeated cycling from the armed to the disarmed positions for at least 1000 cycles, with current flow as specified herein, without any malfunction, failure, or deterioration in performance. During this cyclic period, the devices shall be capable of being manually disarmed after any cycle.

5.15.1.2 RF susceptibility. The attenuation provided by the electro-explosive subsystem device(s) when in the safe position shall be 20 dB, minimum, between circuits, including switch contacts, over the 150 KHz to 40 GHz frequency spectrum.

5.15.1.3 Stall-arming characteristics. The devices shall be capable of meeting all performance requirements after the application of maximum operational arming voltages continuously for periods up to and including 1 hour with safing pin installed, after cooling to within the temperature tolerances specified in method 105 of this standard.

5.15.1.4 Electrical arming and safing time. The time required to arm or to safe a safe and arm device, electrically actuated arm and disarm device, or other approved safing and controlling device(s) shall not exceed 1 second after application of the actuation signal.

5.15.2 Mechanical actuation. Mechanically actuated devices shall withstand repeated cycling from the armed to the disarmed positions for at least 300 cycles without any malfunction, failure, or deterioration in performance. During this cyclic period, the devices shall be armed and disarmed by the same means. The devices shall be capable of being manually disarmed after any cycle. Mechanically actuated devices shall incorporate a mechanical means of safing. During system assembly, checkout and launch, electrically monitoring of the arm or disarm status of the devices shall be provided. In this mode, the devices shall not be capable of being manually armed, but they shall be capable of being manually disarmed. Disarming shall be accomplished without passing through the arm position. The device(s) shall remain mechanically secured in the selected position under all operational environments without the application of any electrical power.

MIL-STD-1512 (USAF)
21 March 1972

5.15.2.1 Safety provisions. The safe and arm device shall contain a mechanical safety barrier between the electrical initiators and the subsequent pyrotechnic or explosive train. In the armed position, the safe and arm safety barrier shall be aligned to permit ignition or detonation of the subsequent pyrotechnic and explosive train; in the safe (disarmed) position, inadvertent ignition of the electrical initiator shall not result in ignition or detonation of the subsequent pyrotechnic or explosive elements. Establishing and breaking circuit continuity, and shorting and unshorting of the electrical initiators shall be accomplished by actuation of the mechanical safety barrier.

5.15.2.2 Safing pin. All devices shall have a positive mechanical lock which will prevent inadvertent transfer from the unarmed or safe position to the armed position. The positive lock shall be capable of removal from the device and shall provide a means of attachment for the installation of warning streamers or other such indicators. It shall, through normal insertion, manually disarm the device (if armed). It shall provide a mechanical lock which will maintain the device in an unarmed or safe position. The positive lock shall be capable of installation into or removal from the device with the device installed. The device shall be retained, by the lock, in an unarmed condition during normal handling, storage, and transportation of the device, subsystem, or system. It shall not be possible to remove this mechanical lock from the device if the arming circuit is energized or, in the case of mechanically actuated devices, if the arming force is applied. The lock or pin and the mating features of the device shall be designed to withstand a torque of at least 375 inch-pounds applied to the pin in either direction without damage to either the pin or the device. Mechanical locking and retaining of the safing pin in the safe position shall be accomplished by rotating the safing pin 90 degrees in a clockwise direction.

5.15.2.3 Streamer (safing pins). All safing pins when installed shall be marked by a streamer in accordance with MS51700.

5.15.2.4 Safe indication. As an integral part of the design, all devices shall include a means for direct visual and remote monitoring of the arm or safe status. The visual indicator shall be clearly and readily discernible at a minimum angle of 15 degrees from the center of the operator's line-of-sight. The safe condition shall be indicated by a white (FED-STD-595 color No. 27875) letter S on a green (FED-STD-595 color No. 24108) background, and the armed condition shall be indicated by a black (FED-STD-595 color No. 27038) letter A on a red (FED-STD-595 color No. 21105) background. Letters shall be readable from 5 feet considering the illumination anticipated for worst case operation. The remote means shall be compatible with the monitor methods and shall not be electrically active.

MIL-STD-1512 (USAF)
21 March 1972

5.16 Environmental requirements. The electroexplosive subsystems shall meet the operational reliability and performance requirements during and after exposure to the following environments:

Method 104	Temperature and humidity
Method 105	Temperature-altitude
Method 106	Thermal shock
Method 107	Moisture resistance
Method 108	Salt spray
Method 109	Fungus
Method 110	Space simulation
Method 112	Steady-state acceleration
Method 113	Vibration
Method 114	Shock
Method 115	Acoustical noise
Method 118	Shelf life
Method 119	Transportation vibration
Method 209	Dent test
Method 301	Explosion
Method 302	Lightning strike induced energy
Method 303	Electromagnetic analysis of the electroexplosive subsystem

5.17 Transportation and handling. The electroexplosive subsystem and its elements shall be designed to withstand ground handling environments as specified herein.

5.17.1 Elevated temperatures. All electroexplosive initiators shall not autoignite nor degrade in performance when subjected to temperatures 50 percent above the maximum temperatures and exposure times specified in method 105 or 106.

5.17.2 Electromagnetic. All electroexplosive subsystems shall be capable of withstanding an RF environment as specified in MIL-STD-461.

5.18 Hermetic sealing. All initiators shall be hermetically sealed in such a manner that after being exposed to the environmental conditions in the sequences specified herein the leakage rate, as determined by a detector gas and measuring device, shall not exceed 10^{-6} cubic centimeters per second at a differential pressure of 0.5 atmosphere, minimum. Organic materials shall not be considered acceptable sealants. The closure(s) used to obtain hermetic sealing, and for other purposes, shall be designed to yield minimum debris as a result of firing; and the debris, if any, shall not have a detrimental effect on the item into which the initiator fires.

5.19 Data. Data in accordance with 6.8 shall be prepared to facilitate the analysis and management of the electroexplosive subsystem. (Also, see 6.6.)

6. QUALITY ASSURANCE PROVISIONS

6.1 Applicable tests. Unless otherwise specified by the procuring activity (see 7.1), all electroexplosive subsystems and components shall pass the applicable tests specified herein.

6.2 Responsibility for inspection. Unless otherwise specified in the contract or purchase order, the supplier is responsible for the performance of all inspection requirements as specified herein. Except as otherwise specified in the contract or order, the supplier may use his own or any other facilities suitable for the performance of the inspection requirements specified herein, unless disapproved by the Government. The Government reserves the right to perform any of the inspections set forth in the standard where such inspections are deemed necessary to assure supplies and services conform to prescribed requirements.

6.3 Test sequences. Unless otherwise specified by the procuring activity (see 7.1), the tests and test sequences in the applicable tables shall be accomplished.

6.4 Classification of inspections. The inspection requirements specified herein are classified as follows:

- a. Hazard classification tests See 6.5
- b. Safety reliability demonstrations See 6.6
- c. Qualification inspections and tests See 6.7
- d. Lot acceptance sampling inspections and tests See 6.8
- e. Quality conformance sampling inspections and tests. See 6.8.

6.5 Hazard classification tests. Tests performed shall determine the hazard classification of each ordnance element.

6.6 Safety reliability demonstrations. The safety reliability of the safe and arm mechanical isolation and other ordnance safety features shall be demonstrated in accordance with MIL-STD-882.

6.7 Qualification inspections and tests. Qualification inspection of ordnance subsystems and components shall be conducted in accordance with the following:

- a. Electroexplosive initiators. Perform the inspections specified in table I.
- b. S&A and A/D devices. Perform the inspections specified in table II.
- c. Electroexplosive subsystem. Perform the inspections specified in table III.

MIL-STD-1512(USAF)
 21 March 1972

TABLE I. Electroexplosive Initiators Qualification Tests - Test Sequence¹

test method	Number of Units Required ²											
	50	50	50	5	10	20	45	50	30	33	180	40
101. Visual inspection	2,16	2,16	2,16	2,9	2,10	2,20	2	2	2	2	2	2
102. Dimensional	1,15	1,15	1,15	1,8	1,9	1,19	1	1	1	1	1	1
103. Radiographic	6,19	6,19	6,19	6,13	6,14	6,23	6	6	6	6	6	6
104. Temperature and humidity	10	10	7			7						
105. Temperature-altitude	12	12	12									
106. Thermal shock						11						
107. Moisture resistance						9						
108. Salt spray						10						
109. Fungus						12						
110. Space simulation						13						
111. Seal effectiveness						14						
112. Steady-state acceleration	11	11	11			15						
113. Vibration	9,14	8,14	9,14			16						
114. Shock	7,13	9,13	10,13	7		17						
115. Acoustical noise						17						
116. Terminal strength	22	22	22									
117. Insulation resistance	3,17	3,17	3,17	3,10	3,11	3,21	3	3	3	3	3	3
118. Shelf life						18						
119. Transportation vibration	8	7	8									
201. Bridgewire resistance	4,18	4,18	4,18	4,11	4,12	4,22	4	4	4	4	4	4
202. Verification of 1 amp/1 watt characteristics	5,20	5,20	5,20	5,12	5,13	5	5	5	5	5	5	5
203. Direct current sensitivity							7					
204. Radio frequency impedance								7				
205. Static discharge sensitivity					8				7			
206. Thermal time constant				14			8	8		7		
207. Radio frequency sensitivity											7	
208. Direct current susceptibility												7
209. Dcnc test	21	21	21		15	24						

Note 1. Numbers indicate sequence of tests

Note 2. Dual bridgewires require 50 percent more electroexplosive initiators

TABLE II. Safe and Arming Device - Qualification Tests

<p><u>33 Units</u></p> <p>Visual inspection - Method 101 Dimensional - Method 102 Operating time - See 5.15.1.4 Manual arming - See 5.15.2 Contact character - Method 310 of MIL-STD-202 Contact resistance - MIL-STD-202 Insulation resistance - Method 117</p>		
<p><u>11 Units</u></p> <p>Transportation vibration - Method 119 Shock - Method 114 Temperature and humidity - Method 104</p>	<p><u>11 Units</u></p> <p>Transportation vibration - Method 119 Temperature and humidity - Method 104 Shock - Method 114</p>	<p><u>11 Units</u></p> <p>Shock - Method 114 Transportation vibration - Method 119 Temperature and humidity - Method 104</p>
<p><u>30 Units</u></p> <p>3. Operational environment - See 5.16 Steady-state acceleration - Method 112 Temperature-altitude - Method 105 Vibration - Method 113</p>	<p><u>3 Units - (One from each series above)</u></p> <p>3. Seal effectiveness - Method 111 Electromagnetic interference - See 4.6.2 Cycle life - See 5.15.1 Fungus - Method 109 Twenty-foot drop test (Shock) - Method 114</p> <p>4. Visual inspection - Method 101</p>	

MIL-STD-1512 (USAF)
 21 March 1972

TABLE III. Electroexplosive Subsystems Test Sequence¹

Test	Number of Units	
	5	1 Analysis
Method 301. Explosion	1	
Method 302. Lightning strike induced energy	2	
Method 303. Electromagnetic analyses of the electroexplosive subsystem		1

Note 1. Numbers indicate sequence of tests.

6.7.1 Regualification testing. A regualification program shall be conducted for any electroexplosive subsystem in accordance with the following, if after successful completion of the qualification test program defined in 6.7, any of the following occurs:

- a. One hundred and eighty calendar days have elapsed since a procurement source (contractor, subcontractor, or vendor) has produced a previously qualified critical component, critical material, or contract end item at a minimum continuous rate of five items per month
- b. Critical components and/or materials are to be obtained from a source not previously qualified
- c. Changes in methods, critical processes, or change in the production line (different line within the same facility or different facility) would invalidate previously conducted qualification tests.

6.8 Lot acceptance sampling inspections and tests. All ordnance systems delivered to the procuring activity or used in qualification inspection programs shall be acceptance tested in accordance with the following:

6.8.1 Electroexplosive initiators. Perform tests as follows:

- a. Dimensional - Method 102
- b. Visual inspection - Method 101

- c. Insulation resistance - Method 117
- d. Verification of 1 amp/1 watt characteristics - Method 202
- e. Radiographic - Method 103
- f. Lot acceptance sampling size - See 6.8.4.

6.8.2 S&A and A/D devices. Perform tests as follows:

- a. Visual inspection - Method 101,
- b. Dimensional - Method 102
- c. Electrical connector verification - See 5.11
- d. Seal effectiveness - Method 111
- e. Vibration - Method 113
- f. Electrical arming and disarming (18V dc and 30V dc) - See 5.15.1
- g. Operation time (18V dc and 30V dc) - See 5.15.1.4
- h. Manual safing - See 5.15.1
- i. Arm and safe indication (visual) - Method 101
- j. Insulation resistance - Method 117

6.8.3 Electroexplosive subsystem. Perform the following tests:

- a. Transportation vibration - Method 119
- b. Temperature and humidity - Method 105
- c. Vibration - Method 113
- d. Steady-state acceleration - Method 112
- e. Temperature-altitude - Method 105
- f. Bridgewire resistance - Method 201
- g. Dent test - Method 209.

MIL-STD-1512 (USAF)
21 March 1972

6.8.4 Lot acceptance sampling size. A lot acceptance sampling inspection shall be under the following procedure and sample sizes. Acceptable quality level (AQL) to be specified by the procuring activity. Sample size shall be determined as follows, and shall be randomly selected from a completed lot:

<u>Lot Size</u>	<u>Sample Size</u>
0 to 180	45
181 to 300	75
301 to 500	110
501 to 800	150
801 to 1,300	225
1,301 to 3,200	300

6.9 Induced energy monitors. Induced energy monitors or detectors used during systems testing shall meet the following requirements:

6.9.1 Monitors which replace electroexplosive devices shall:

- a. Have the same electrical characteristics as the electroexplosive devices they replace
- b. Measure only the parameter for which they were designed, and should have sufficient rejection so that crosstalk from other modes does not degrade the data
- c. Have the required sensitivity prescribed by the test conditions
- d. Have been tested to all electrical tests specified in this standard.

6.9.2 Monitors which are external to the electroexplosive subsystem under test shall:

- a. Not introduce into the electroexplosive subsystem or incident field any changes from conditions before the monitor was inserted
- b. Be sufficiently compact so that a recorder can be used, and so designed that the recorder does not change the characteristics of the monitor
- c. Use as short cable length as possible, when remote recording is used
- d. Be capable of triggering a warning device or indicator circuit
- e. Provide a continuous record of induced energy
- f. Identify the mode of pickup.

MIL-STD-1512 (USAF)
21 March 1972

6.10 Deliverable data. Data generated by this document, if deliverable, should become part of and be supplied as part of the system safety plan or the system EMI control plan. When neither of these plans exist, this plan shall be procured by use of a DD form 1423.

6.11 Publications. In the design of electroexplosive subsystems, consideration should be given to information contained in AFSC Design Handbooks DH 1-4, DH 1-6, and DH 2-5.

6.12 Tailoring of requirements and limits. Requirements and limits can be tailored to the extent specified in the applicable procurement documents.

6.13 Documentation. Documentation shall be provided to allow management and design review, to assure uniform test and/or analysis for design qualification and product acceptance, and to provide the necessary procedures and instructions for installation, checkout, performance, inspection, maintenance, disposal, and other functional operations necessary to the intended usage of the control, monitor, and initiation subsystems. Nondeliverable documentation and data shall be available for review and use by the procuring activity. The contract data requirements list (CDRL) for each specific contract shall specify deliverable data items, the schedules, the required contents and formats, and other similar instructions for delivery of the data items. This paragraph is not a requirement for procurement or delivery of data which is accomplished by contract (Contract Data Requirements List - DD form 1423).

6.13.1 Management and design review documentation. When practicable, the data required to allow management and design review of control, monitor, and initiation subsystems for electroexplosive subsystems shall be included in program and/or system documentation rather than as a separate data submittal. Documentation for this purpose shall not result in duplication of data submittals or submittal of duplicate data. This documentation shall include, but not be limited to the following:

6.13.1.1 Plan. A plan for managing and controlling the required activities shall be provided and maintained current. The plan shall include the following information as a minimum:

6.13.1.1.1 The plan shall identify the administration and management structure and clearly define: (a) responsibilities for the design of control, monitor, and initiation subsystems of electroexplosive subsystems; (b) organizational relationships between the program office, design groups, and other areas of responsibility; and (c) lines of authority and control. A similar definition related to subcontractor developed subsystems and/or components, Government-furnished equipment, and vendor off-the-shelf items shall be included.

MIL-STD-1512 (USAF)
21 March 1972

6.13.1.1.2 The plan shall describe the subsystem and/or component, its operation, and the interrelation with the remainder of the system.

6.13.1.1.3 The plan shall include subsystem/component development and test schedules and milestones, including hardware qualification and documentation delivery.

6.13.1.1.4 The plan shall contain the proposed tailoring of the design, test, and documentation requirements contained herein as applicable for a specific application with complete technical justification and evaluation of contractual, schedule, and cost impacts.

6.13.1.1.5 The plan shall delineate the technical controls, concepts, and techniques which will be applied during the design of the subsystem and/or components to assure compliance with the requirements.

6.13.1.2 Design documentation. Design drawings and other documentation which support the design shall be provided to allow design review and approval. This documentation shall describe the design and the implementation of the technical controls, concepts, and techniques delineated in the plan. This documentation shall include, but not be limited to:

- a. Functional diagrams
- b. Logic diagrams
- c. Circuit schematics
- d. Detailed electrical, mechanical, electrical referencing assembly, and other similar drawings
- e. Tradeoff study results, and
- f. Analyses and data which assure that compliance of the end item design with the contractual requirements will be accomplished.

6.13.1.3 Test/analysis documentation. When practicable, the documentation required to assure uniform test and/or analysis for design qualification and product acceptance shall be included in program and/or system documentation rather than as a separate data submittal. Documentation for this purpose shall not result in duplication of data submittals or submittal of duplicate data.

6.13.1.4 Qualification plan. A qualification plan shall be provided. This plan shall describe in detail the tests and/or analyses required to determine

the performance characteristics of the end item and to confirm that the contractual requirements have been satisfied by the end item design. For each test and/or analysis, the plan shall provide for cross correlation between the characteristic to be determined, the contractual requirement to be satisfied, and the details and controls to assure valid tests, analyses, data, and conclusions.

6.13.1.5 Qualification report. A qualification report shall be provided to document the tests/analyses performed, the results of the tests/analyses, compliance with the contractual requirements, and evaluation of the adequacy of the equipment to perform its intended function without degrading the total system performance or reliability. The report shall include, but need not be limited to, such specific details as:

- a. A cover page to include the security classification (if other than unclassified), title, report number, date of issue, and distribution limitations (if applicable)
- b. A narrative description of the effort performed with emphasis on and justification for any deviation from the procuring-activity-approved qualification plan
- c. Nomenclature, serial number, and complete identification of test equipment
- d. Dates of last calibration and next scheduled calibration of test equipment
- e. Description of the test site and test setup with photographs, diagrams, illustrations, etc, as required for clarity
- f. Methods of operating the test sample and equipment
- g. Control settings of the test sample and equipment
- h. Measured line voltages, currents, impedances, and frequencies
- i. Correction factors, sample calculations, and methods used to reduce data
- j. Explanation of special terms and abbreviations
- k. Comparison of the contractual requirements and the performance characteristics determined by test/analysis, and
- l. Evaluation of the adequacy of the equipment to perform its intended function without degrading the total system performance or reliability.

MIL-STD-1512 (USAF)
21 March 1972

6.13.1.6 Acceptance documentation. Acceptance tests are sometimes required to assure that individual items of equipment are the same as the item tested for design qualification. When such tests are required, the specific tests to be performed shall be documented and approved by the procuring activity prior to commencing the tests. Unless otherwise specified in the applicable acceptance requirements, the tests shall be identical to those performed to determine the same characteristic during design qualification. The results of the acceptance tests shall be documented in a report containing the same information as the qualification report and including the performance characteristics determined during both qualification and acceptance testing.

6.13.1.7 Specialized documentation. Documentation is required to provide the procedures and instructions necessary to the intended usage of equipment. This usually takes the form of technical orders and/or manuals or specific inputs from which these documents are prepared. In addition, explosive components such as electroexplosive devices often require specialized documentation including the following:

- a. Explosive Component Technical Data Sheet (DOD ADL TD-3, DI-L-3111) is used to acquire data for the preparation of military explosive hazard classification for explosive items/subassemblies.
- b. Explosive Ordnance Disposal Procedures (DOD ADL TD-3, DI-M-3403) provide a basis for a specialized technical order and are necessary prior to use of explosive items.
- c. Data Cards for Explosive Assemblies, Subassemblies, and Parts (DOD ADL TD-3, DI-L-3317) is required at the time the explosive-type items enter the Air Force inventory.

6.13.1.8 Qualification requirements. Performance qualification of the design of end items and subsystems which control, monitor, and initiate electroexplosive subsystems shall be accomplished prior to final design approval. Each explosive component lot shall be tested in sufficient quantity to demonstrate a reliability of 0 to .995 at a confidence level of 95 percent for each ordnance train interface. Such tests shall be successfully completed prior to release of the lot for manufacturing.

6.13.1.9 Conditions for testing. The conditions for qualification testing shall be detailed in the test plan and approved by the procuring activity prior to the start of testing. The following considerations are essential, but not necessarily sufficient to assure adequate test conditions:

6.13.1.9.1 Test equipment. Provisions shall be incorporated to assure that test instrumentation and equipment do not impact the accuracy of the test data.

6.13.1.9.2 Environment. The ambient environment which will exist during testing shall be evaluated with respect to test and/or data impact and, if necessary, shall be controlled to minimize such impacts and assure test repeatability.

7. NOTES

7.1 Consideration should be given the following when referencing this standard:

- a. When metallic parts are to be bonded other than as specified in 4.5
- b. When safety margins are to be other than as specified in 4.6.2
- c. If minimum service life is to be other than 10 years (see 4.6.3)
- d. Mounting of the electroexplosive initiator (see 5.13.2)
- e. If the electrical design requirements of the electroexplosive initiators are to be other than as specified in 5.14.1
- f. When applicable tests are to be other than as specified in 6.1
- g. Test and test sequence (see 6.3).

8. TEST METHODS

8.1 Individual methods for testing follow.

Custodian:
Air Force - 11

Preparing activity:
Air Force - 11

Reviewers:
Air Force - 10, 13, 15, 18, 19, 21,
22, 26, 70, 79, 80, 82, 84

Project No. MISC-0643

MIL-STD-1512 (USAF)

21 March 1972

METHOD 101

VISUAL INSPECTION

1. Purpose. The purpose of the test is to visually inspect the item before and after each manufacturing, handling, storage, and test operation.
2. Procedure. Visually inspect the item before and after test to insure that good workmanship has been employed and that the item is free of obvious physical defects. This inspection should in no way interfere with any subsequent performance or requirement.
3. Summary. Any know recurring defects shall be specified in the individual specification.

METHOD 102

DIMENSIONAL

1. Purpose. The purpose of this test is to establish the dimensional accuracy of the item to be tested.
2. Procedure. Each item to be tested shall be physically measured to insure that the accuracy of the configuration is within dimensional limits.
3. Summary. The following details shall be specified in the individual specification:
 - (a) All physical dimensions needed to adequately describe the configuration limits.

MIL-STD-1512 (USAF)
21 March 1972

METHOD 103

RADIOGRAPHIC

1. Purpose. The purpose of this inspection is to radiographically inspect the material for defects.
2. Procedure. The radiographic test shall be accomplished by the methods outlined in MIL-STD-453.
3. Summary. Radiographic quality levels if other than 2-2T of MIL-STD-453 shall be specified in the individual specification.

METHOD 104

TEMPERATURE AND HUMIDITY

1. Purpose. This test is performed to evaluate the characteristics of the item under test in a controlled temperature and humidity environment to insure reliability and safety.
2. Procedure. The item under test shall be subjected to one 14-day Jan temperature and humidity cycle in accordance with MIL-STD-331, test 105, except the temperature extremes shall be -35° and $+125^{\circ}\text{F}$.
3. Summary. The 14-day cycle was chosen as the basic unit because this period is considered the most applicable environment in which the item under test is operated. If other temperature values are required, they shall be specified in the individual specification.

MIL-STD-1512 (USAF)
21 March 1972

METHOD 105

TEMPERATURE - ALTITUDE

1. Purpose. The purpose of the test is to determine whether or not the electroexplosive subsystem, or its components, will operate without degradation of performance in the operational temperature altitude environment envelope of the system.
2. Procedure. The electroexplosive system, or its component parts, shall be tested in accordance with MIL-STD-810, method 504. Any evidence of arc-over, corona, or any other defect or degradation that would affect safety or reliability of the electroexplosive subsystem shall be considered a failure.
3. Summary. As a minimum, the following details shall be specified in the individual specification:
 - a. Test condition letter
 - b. Special mounting, if applicable
 - c. Environmental envelope
 - d. Initial measurement
 - e. Final measurement
 - f. Failure criteria.

METHOD 106

THERMAL SHOCK

1. Purpose. This test is conducted to determine if safety and reliability of electroexplosive subsystems are degraded under conditions of rapidly changing temperatures. Such thermal shocks can occur when changing altitudes, when moving equipment from warm buildings to outdoor arctic areas, and re-entry.
2. Procedure. The electroexplosive subsystem shall be tested in accordance with MIL-STD-202, method 107. Any evidence of degradation affecting safety or reliability shall be considered a failure.
3. Summary. The following details shall be specified in the individual specification:
 - a. Special mounting
 - b. Test condition letter
 - c. Initial and final measurements
 - d. Failure criteria.

MIL-STD-1512 (USAF)
21 March 1972

METHOD 107

MOISTURE RESISTANCE

1. Purpose. The moisture resistance test is performed to evaluate, in accelerated time, the characteristics of an electroexplosive subsystem that will ensure safety and reliability under high humidity and temperature conditions. Degradation can occur due to corrosion, decomposition of organic materials, changes in electrical properties, etc.
2. Procedure. The electroexplosive system, or its component parts, shall be tested in accordance with MIL-STD-202, method 106. Any evidence of degradation that prevents the electroexplosive subsystem from meeting the safety and reliability requirements shall be considered a failure.
3. Summary. The following details shall be specified in the individual specification:
 - a. Initial measurement
 - b. Final measurement
 - c. Failure criteria.

METHOD 108

SALT SPRAY

1. Purpose. The salt spray test is performed to determine whether or not the protective coatings, metallic and nonmetallic, on the component parts of the electroexplosive subsystem prevent degradation of safety and reliability. The test is also useful when evaluating different lots of components, once a standard level of performance is known.

2. Procedure. The electroexplosive subsystem, or its component parts, shall be tested in accordance with MIL-STD-202, method 101. Any evidence of degradation affecting safety or reliability shall be considered a failure.

3. Summary. The following details shall be specified in the individual specification:

- a. Applicable salt solution
- b. Special mountings and details
- c. Test condition letter
- d. Initial measurement
- e. Final measurement
- f. Failure criteria.

MIL-STD-1512 (USAF)
21 March 1972

METHOD 109

FUNGUS

1. Purpose. This test is conducted to evaluate the effects of fungi on safety and reliability. Fungi excrete enzymes that can destroy most organic materials and their derivatives.
2. Procedure. The test shall be conducted in accordance with MIL-STD-810, method 508. Any evidence of degradation affecting safety or reliability shall be considered a failure.
3. Summary. The following details shall be specified in the individual specification:
 - a. Special details of test
 - b. Initial and final measurements
 - c. Failure criteria.

METHOD 110

SPACE SIMULATION

1. Purpose. This test is conducted to evaluate the effects of solar energy upon safety and reliability of electroexplosive subsystems and components. This test simulates a space environment except for functions such as zero gravity, micrometeorite hits, high energy particles, etc.

2. Procedure. The test shall be based on MIL-STD-810, method 517. Any evidence of degradation affecting safety or reliability shall be considered a failure.

3. Summary. The following details shall be specified in the individual specification:

- a. Special details of test
- b. Initial and final measurements
- c. Failure criteria.

MIL-STD-1512 (USAF)
21 March 1972

METHOD 111

SEAL EFFECTIVENESS

1. Purpose. This test is performed to evaluate the integrity of hermetic seals, gasket seals, and degradation of safety and reliability.
2. Procedure. The test shall be in accordance with MIL-STD-202, method 112, except that measurements shall be performed on the test sample to determine degraded performance. This test normally shall be run after other required environmental tests that can aggravate incipient defects in hermetic seals or gaskets. Any malfunction or degradation of performance affecting safety or reliability shall be considered a failure.
3. Summary. The following details shall be specified in the individual specification:
 - a. Special details for test
 - b. Initial and final measurements
 - c. Failure criteria.

METHOD 112

STEADY-STATE ACCELERATION

1. Purpose. This test is performed to determine degradation of safety and reliability of electroexplosive subsystems and components under steady-state acceleration, other than gravity.

2. Procedure. The test shall be in accordance with MIL-STD-202, method 212, procedure II, except that factors affecting safety shall be given special emphasis. Any evidence of malfunction or degradation of performance shall be considered a failure.

3. Summary. The following information shall be specified in the individual specification:

a. Special test details to include conditions which will impose loads on terminals

b. Initial and final measurements

c. Failure criteria.

MIL-STD-1512 (USAF)
21 March 1972

METHOD 113

VIBRATION

1. Purpose. The purpose of this test is to evaluate the safety and reliability characteristics of electroexplosive subsystems and components under vibration conditions.
2. Procedure. The test shall be in accordance with MIL-STD-202, method 201. Any evidence of malfunction or degradation of performance affecting safety or reliability shall be considered a failure. Components shall be tested with cables and connectors attached.
3. Summary. The following information shall be specified in the individual specification:
 - a. Test curve
 - b. Special details for test including conditions which will impose normal loads on terminals
 - c. Initial and final measurements
 - d. Failure criteria
 - e. Procedure number.

METHOD 114

SHOCK

1. Purpose. This test is to determine degradation of safety or reliability of electroexplosive subsystems and components under conditions of shock.
2. Procedure. The test shall be in accordance with MIL-STD-202, method 213, except that method 516, procedure III, crash safety, of MIL-STD-810 shall be used to evaluate safety under crash conditions. Any evidence of malfunction or degradation of performance of safety or reliability shall be considered a failure. Components shall be tested with cables and connectors attached.
3. Summary. The following information shall be specified in the individual specification:
 - a. Special details for test
 - b. Initial and final measurements
 - c. Failure criteria
 - d. Procedure number.

MIL-STD-1512 (USAF)
21 March 1972

METHOD 115

ACOUSTICAL NOISE

1. Purpose. This test is performed to evaluate the effects of acoustic noise fields upon the safety and reliability characteristics of electro-explosive subsystems and components. This test is not a substitute for sinusoidal and random vibration. In general, subsystem and components so installed that they will not be exposed to acoustic noise levels greater than 130 dB over the life cycle of the system, subsystem, or component, shall not require testing.
2. Procedure. The test shall be in accordance with MIL-STD-810, method 515. Any malfunction or degradation of performance affecting safety or reliability shall be considered a failure.
3. Summary. The following details shall be specified in the individual specification:
 - a. Special details of test
 - b. Test grade
 - c. Initial and final measurements
 - d. Failure criteria.

METHOD 116

TERMINAL STRENGTH

1. Purpose. The purpose of this test is to determine that electrical terminals used in electroexplosive subsystems and components have adequate strength under the mechanical handling stresses encountered during the service environment of a system. The tests to be made on terminals are:

- a. Tension
- b. Torque
- c. Lead fatigue
- d. Bending stress.

2. Procedure. The test shall be performed in accordance with MIL-STD-202, method 211. Any evidence of degradation affecting safety or reliability shall be considered a failure.

MIL-STD-1512 (USAF)
21 March 1972

METHOD 117

INSULATION RESISTANCE

1. Purpose. The purpose of this test is to measure the insulation resistance of electroexplosive subsystems and components. This test is primarily useful in detecting leakage, and other effects degrading safety.
2. Procedure. The test shall be in accordance with MIL-STD-202, method 302. Any evidence of malfunction or degradation of performance affecting safety or reliability shall be considered a failure. This test shall be performed after the dielectric withstanding voltage test.
3. Summary. The following details shall be specified in the individual specification:
 - a. Special test details
 - b. Test condition letter
 - c. Initial and final measurements
 - d. Limits
 - e. Test voltage
 - f. Failure criteria.

METHOD 118

SHELF LIFE (ENVIRONMENTAL CONDITIONS)

1. Purpose. This shelf life test is conducted to determine whether or not the effects of exposure to elevated temperatures for specified time periods will degrade electrical and mechanical characteristics of electroexplosive subsystems components. In some cases, tests must be run to determine if degradation has occurred.
2. Procedure. The electroexplosive subsystem, or its components, shall be tested in accordance with MIL-STD-202, method 206. Any evidence of degradation affecting safety or reliability shall be considered a failure.
3. Summary. The following details shall be specified in the individual specification:
 - a. Distance from specimens where temperature measurements are to be made
 - b. Still air requirement (see test method)
 - c. Method of mounting, and distance between specimens
 - d. Test temperature and tolerances
 - e. Operating conditions
 - f. Test condition letter
 - g. Initial measurement
 - h. Final measurement
 - i. Failure criteria.

MIL-STD-1512 (USAF)
21 March 1972

METHOD 119

TRANSPORTATION VIBRATION

1. Purpose. The purpose of this test is to insure major consideration during design to provide protection against deterioration or damage during handling, shipment, and storage of electroexplosive subsystems and components.
2. Procedure. The test shall be conducted in accordance with MIL-STD-331, method 104. (References to fuses in method 104 shall be considered to refer to all electroexplosive subsystem components.)

METHOD 201

BRIDGEWIRE RESISTANCE

1. Purpose. The purpose of this test is to measure the resistance of the bridgewire.
2. Procedure. Bridgewire resistance shall be measured applying a maximum current of 10 percent of the maximum no-fire current in the test circuit. An accuracy of at least 2 percent is required.

MIL-STD-1512 (USAF)
21 March 1972

METHOD 202

VERIFICATION OF 1 AMPERE/1 WATT CHARACTERISTICS

1. Purpose. The purpose of this test is to demonstrate the ability of the electroexplosive device to withstand a maximum energy dissipation without dudding or firing.
2. Procedure. This test shall be performed by applying to each bridgewire or set of pins for a minimum of 5 minutes, a minimum of 1.0 amp and 1 watt dc, whichever results in the maximum energy dissipation.
3. Summary. Dudding or firing of the unit under test shall be cause for failure.

METHOD 203

DIRECT CURRENT SENSITIVITY

1. Purpose. The purpose of this test is to measure the direct current characteristics of electroexplosive initiators, no-fire sensitivity, all-fire sensitivity, and degradation of sensitivity.
2. Procedure:
 - a. Forty-five initiators are required
 - b. Environmental conditions shall be as specified in the individual specification. Environmental tests shall be run in the required sequence
 - c. A statistical analysis in accordance with MIL-I-23659 shall be conducted to determine the maximum no-fire and all-fire sensitivity to a reliability of 0.995 at a 95-percent confidence level.

MIL-STD-1512 (USAF)
21 March 1972

METHOD 204

RADIO FREQUENCY IMPEDANCE

1. Purpose. The purpose of this test is to measure the radio frequency impedance of electroexplosive devices so that sensitivity at radio frequency can be determined.
2. Apparatus. Impedance measuring equipment shall be capable of measurement at extremely low radio frequency levels so that the electroexplosive devices are not subjected to heating effects. Automatic equipment is preferred. See figure 204-1 for typical equipment. This setup and equipment will permit measurements with 10^{-12} watts of radio frequency power applied to the electroexplosive device; however, any equipment suitable for the frequency range can be used.
3. Procedure:
 - a. When specified, electroexplosive devices should be preconditioned by running them through the environmental conditions
 - b. Measure each electroexplosive device at a sufficient number of points to properly define the impedance curve
 - c. Keep the radio frequency power from the signal source at the lowest level that permits accurate measurements. If too high a level is used, the heating effect will cause a large change in impedance
 - d. Plot the results on a standard Smith chart and indicate the mean, maximum, and minimum values. Plot resistance, reactance, and vector impedance.
 - e. Unless otherwise specified, a frequency range of 1 MHz to 18 GHz shall be used.
4. Summary. The following information shall be specified in the individual specification:
 - a. Number of electroexplosive devices to be tested
 - b. Special details of test.

MIL-STD-1512 (USAF)
21 March 1972

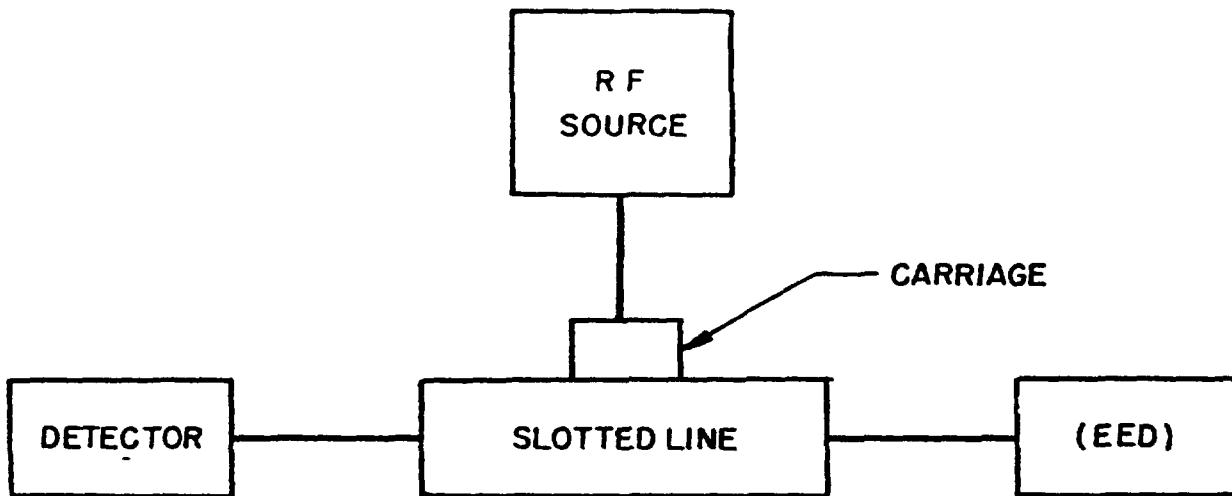

NOTES:

1. Signal source - Any laboratory quality generator that will operate at the required frequency and which will provide sufficient power to give a signal approximately 10 dB above detector noise levels at voltage minimum.
2. Slotted line - Should be of rigid mechanical construction with extremely low losses and of constant characteristic impedance. Preferably, it should have air dielectric and a narrow slot. To use the above connection, the crystal must be removed from the carriage and replaced by a conductor. Other measuring devices can be used when suitable slotted lines are not available.
3. EED mount - Mount EED to simulate configuration in actual installation.
4. Detectors - Receivers of about 1 microvolt sensitivity. Other detectors (crystal, bolometer, etc) can be used if they are sufficiently sensitive to avoid heating effects.

Figure 204-2 Typical RF Impedance Measurement

MIL-STD-1512 (USAF)
21 March 1972

METHOD 205

STATIC DISCHARGE SENSITIVITY

1. Purpose. The purpose of this test is to test the safety of an electro-explosive device under electrostatic discharge conditions.
2. Procedure:
 - a. Thirty electroexplosive devices are required
 - b. Precondition the test item by performing the necessary environmental tests
 - c. Establish the environmental conditions for this test and let stabilize for the required time
 - d. Discharge 25 kv from a 500-pfd capacitor applied through a 5k resistor at the test points. All possible modes, such as pin-to-case, pin-to-pin, etc, shall be tested. Figure 205-1 shows the static discharge test circuit
 - e. Perform the test statistically in accordance with Handbook 106.
3. Note. Since in general, human charges rarely exceed 25,000V, any functioning at lower voltage indicates a definite personnel hazard. Some flexibility can be obtained in performing these tests if nonfires from other tests are utilized for testing to determine the most hazardous mode. Then, all 30 electroexplosive devices can be tested in that mode. If no mode shows any specific evidence of sensitivity, equal numbers of electroexplosive devices can be tested for each mode or retested in two or more modes. This flexibility should permit maximum information to be obtained with minimum expense.

MIL-STD-1512 (USAF)
21 March 1972

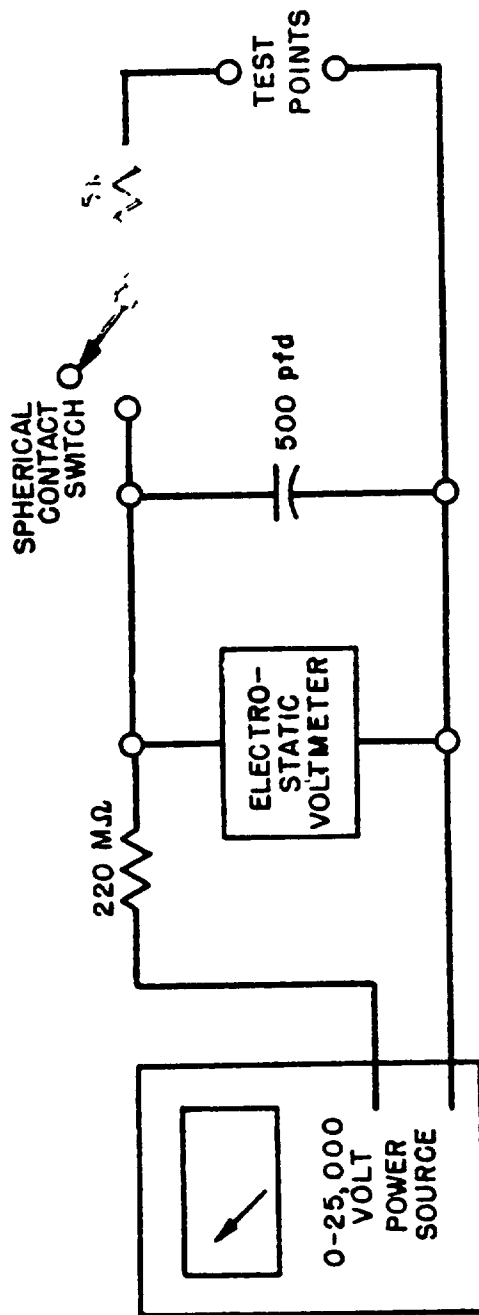

Figure 205-1. Static Discharge Test Circuit

MIL-STD-1512 (USAF)
21 March 1972

METHOD 206

THERMAL TIME CONSTANT

1. Purpose. The purpose of this test is to measure the thermal time constant of electroexplosive initiators.

2. Procedure:

a. Measure the temperature increase in the bridgewire when a constant current is passed through it for 10 milliseconds. The temperature rise is measured by using a constant current pulse and measuring the voltage drop across the bridgewire as a function of time.

b. A time of 10 milliseconds is recommended as in this time the effect of the material within about a 2 mil radius of the wire has already contributed to the conductivity and the major temperature rise of the wire has been achieved. From this time on, the temperature rises very slowly and only as a result of heat capacity effects and remote boundaries within the system.

c. It is customary to ignore the first millisecond, since omitting the first millisecond rise will not affect the usefulness of the measurement, but only the absolute size of the numbers measured.

d. Figure 1 shows a circuit designed for the measurement of the thermal time constant of bridgewires by measuring the increase in the bridgewire temperature from 1 to 10 milliseconds after the application of a 1-amp pulse, 10 milliseconds long. The voltage drop across the bridgewire under test is fed through an amplifier that increases the voltage to about 10V for convenience in measurement. The pulse is then fed to two peak follower units, one of which follows the pulse for only 1 millisecond and the other for the full pulse length. The outputs of these two units are then fed to a differential amplifier which subtracts the two values and sends the difference to a digital voltmeter which displays the voltage increase (or resistance change) that occurred between 1 and 10 milliseconds.

e. This gives a fast, reliable, direct reading measurement of the thermal time constant. Since the pulse is short and total energy low, the measurement may be repeated after a few seconds when temperature equilibrium has been reached again. A storage oscilloscope similar to the Tektronix 549 should be used to monitor the pulse so that one may observe the detailed pulse shape on any anomalous pulses without taking oscilloscope pictures.

MIL-STD-1512 (USAF)
21 March 1972

f. One-hundred-percent inspection of electroexplosive initiators is suggested. This technique modifies the performance distribution since the tails of the distribution have been severely limited. This has the affect of making the distribution much narrower than would be indicated by a standard Bruceton test which concentrates its measurements in the center of the distribution.

g. The thermal time constant measurement is an extremely valuable test from both cost and quality standpoints. As higher and higher reliability levels are imposed, the stray item which significantly modifies the standard deviation can have disasterous effects on the acceptability of a lot. This nondestructive test can locate and remove such item.

MIL-STD-1512 (USAF)
 21 March 1972

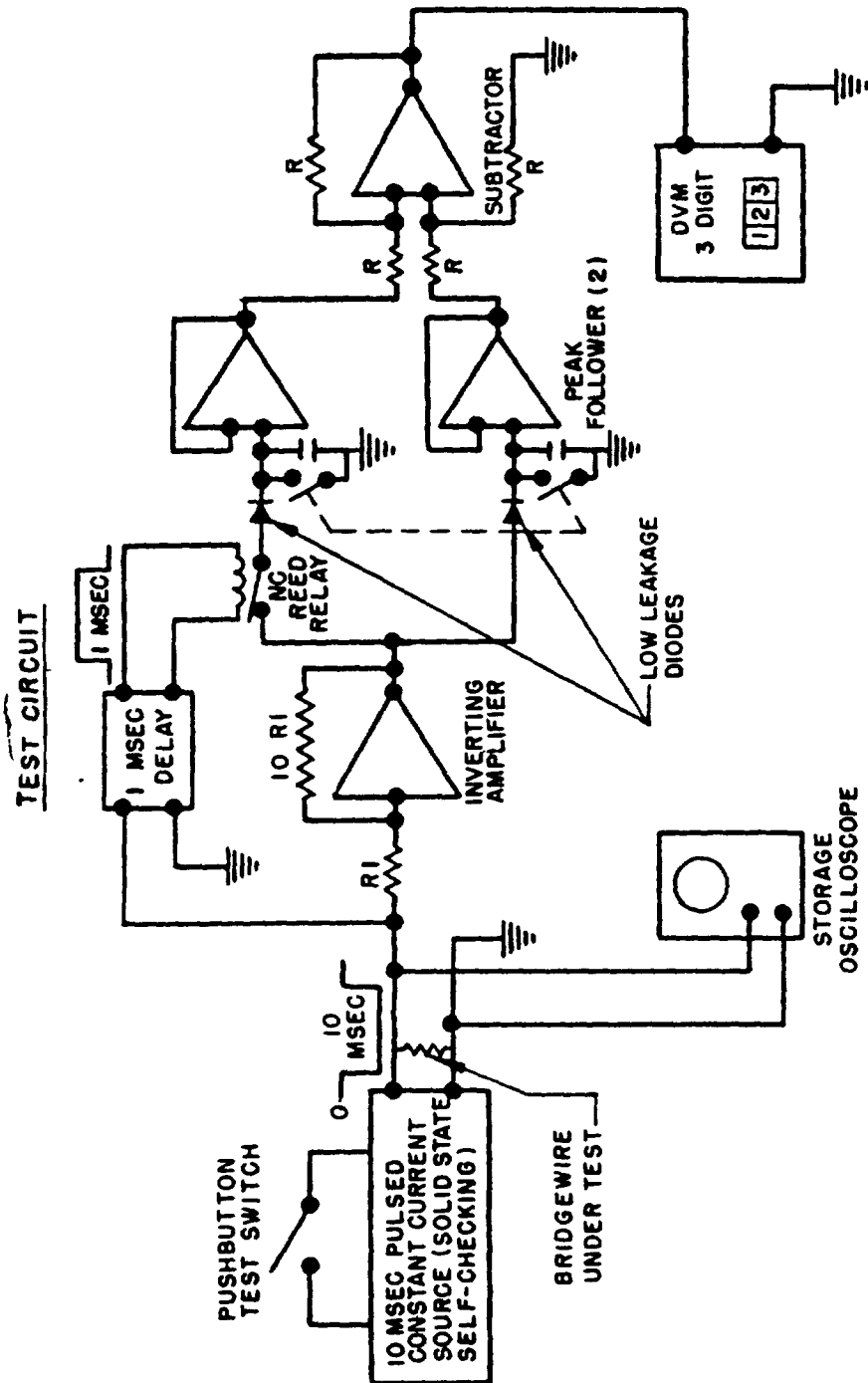

Figure 206-1. Thermal Time Constant Test Circuit

METHOD 207

RADIO FREQUENCY SENSITIVITY

1. Purpose. The purpose of this method is to measure the radio frequency sensitivity of electroexplosive devices.

2. Procedure:

a. Number of electroexplosive devices required:

(1) Single bridgewire type - 180

(2) Dual bridgewire type - 270

Note: Nonfires from this test can be used for other test methods.

b. Basic radio frequency test

(1) At each radio frequency to be used in the test, calculate the radio frequency power to be applied to the electroexplosive devices by using the mean dc firing current measured in method 203 and the radio frequency impedance measured in method 204. This calculated level will be applied to the devices in each mode (ie, pin-to-pin, pin-to-case, bridgewire-to-bridgewire). See figure 207-1 for a typical test setup.

(2) Ten electroexplosive devices will be tested for each mode with the radio frequency level calculated above applied for 10 seconds each. In general, if two or less fire, it can be stated with very small risk that the electroexplosive devices are less sensitive to the test condition than they are to direct current, and the direct current sensitivity level can be used for subsequent analysis. If from three to seven electroexplosive devices fire, they can be considered to be of the same order of sensitivity as the direct current susceptibility level, and the direct current level can be used in subsequent calculations with a risk of approximately 11 percent. If eight or more fire, there is little doubt that the electroexplosive device is more sensitive than the direct current level and more thorough testing is indicated.

(3) At least 10 radio frequencies will be used, selected from transmitters installed on the system or as designated by the procuring activity

MIL-STD-1512 (USAF)

21 March 1972

(4) At each test frequency, ten electroexplosive devices will be tested in the pin-to-pin mode and ten in the pin-to-case mode. If the electroexplosive device has dual bridgewires, test 10 more in this mode. Up to five electroexplosive devices that did not fire in the pin-to-pin test can be used in the pin-to-case test.

c. Statistical radio frequency tests:

(1) Eighty electroexplosive devices are required.

(2) From the data obtained in 2b, determine the two most sensitive conditions (frequency and firing mode). If no explicit conditions can be identified, the statistical tests can be performed at specific frequencies which may be of interest, such as onboard telemetry or communications.

3. A statistical analysis in accordance with MIL-I-23659 shall be conducted to determine the radio frequency firing sensitivities to a reliability of 0.95 at a 95 percent confidence level.

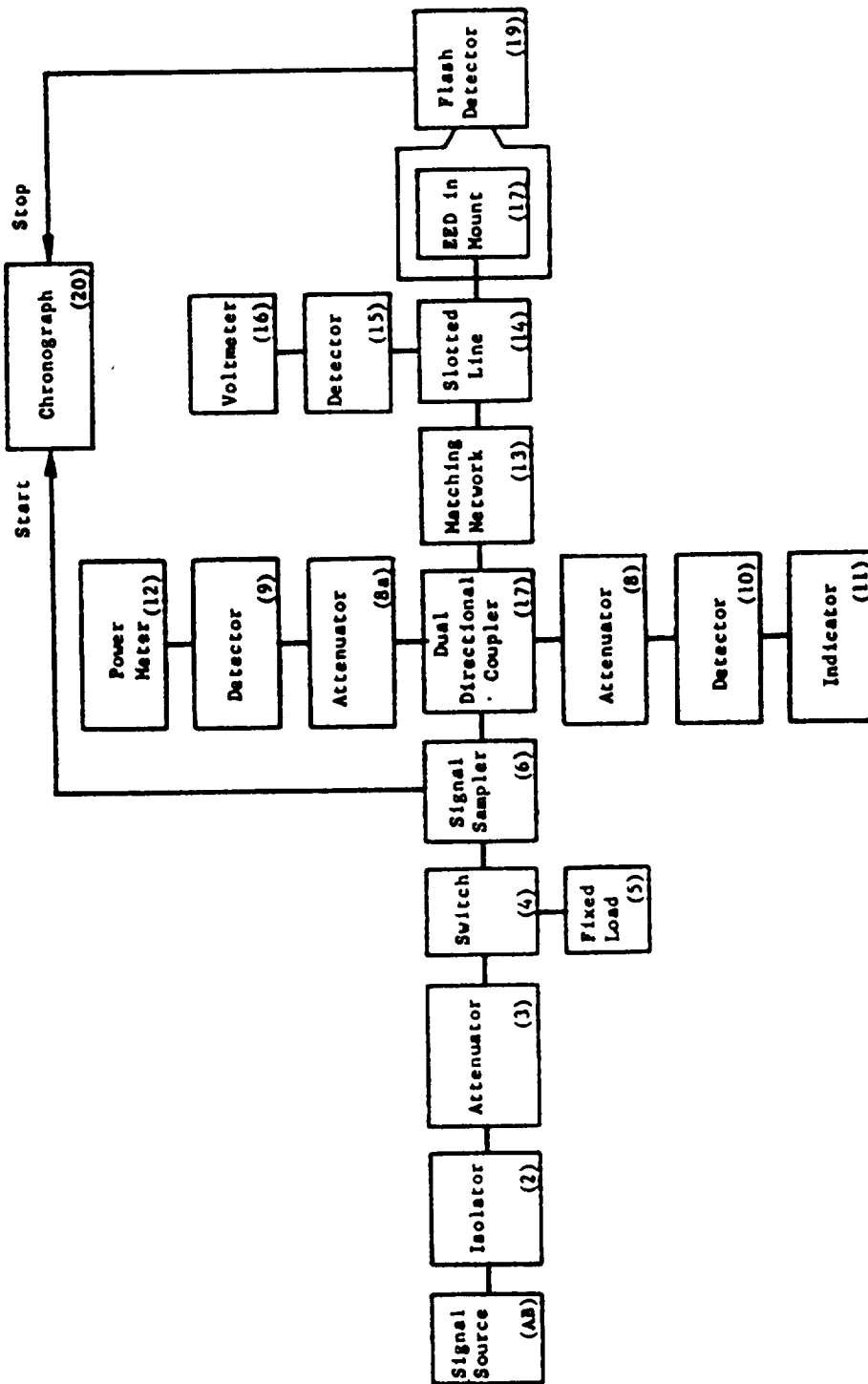

Figure 207-1. Typical Test Setup For Radio Frequency Sensitivity

MIL-STD-1512 (USAF)
21 March 1972

METHOD 208

DIRECT CURRENT SUSCEPTIBILITY

1. Purpose. The purpose of this test is measure the direct current susceptibility of electroexplosive devices under conditions of constant current and variable pulse widths.

2. Procedure:

a. Ten-second pulse

(1) Forty electroexplosive devices are required.

(2) From the data obtained from test method 207, determine the firing mode (pin-to-pin, pin-to-case, etc), and the radio frequency to which the electroexplosive devices are most sensitive. Using this frequency and mode, precondition the 40 electroexplosive devices by applying for 5 minutes, radio frequency energy at a level equal to 10 percent of the average at which the electroexplosive devices fired during the tests for method 207.

(3) After this radio frequency conditioning, if the electroexplosive devices have not fired, perform a statistical test using direct current constant current pulses of 10 seconds duration.

b. One-millisecond pulse

(1) Forty electroexplosive devices are required.

(2) Repeat the above procedures using constant current direct current pulses of 1 millisecond duration.

c. Ten-millisecond pulse

(1) Forty electroexplosive devices are required

(2) Repeat the above procedures using constant current direct current pulses of 10 milliseconds duration.

MIL-STD-1512 (USAF)
21 March 1972

d. One-hundred millisecond pulse

(1) Forty electroexplosive devices are required.

(2) Repeat the above procedures using constant current direct current pulses of one-hundred milliseconds duration.

3. Notes:

a. The data obtained from this test are used for (1) a constant current sensitivity curve and (2) estimation of radio frequency pulses necessary for firing.

b. The currents for the 50 percent probability of fire and the standard deviation will be compared with the corresponding values from the statistical sensitivity test of MIL-I-23659 of the unconditioned initiators to determine the extent to which the initiators are degraded.

MIL-STD-1512 (USAF)
21 March 1972

METHOD 209

DENT TEST

1. Purpose. This test is performed to determine if the electroexplosive initiators fire within the required pressure output and uniformity.
2. Procedure. This test shall be conducted in accordance with MIL-STD-331, method 303.
3. Summary. The following information shall be specified in the individual specification:
 - a. Criteria for passing test, ie, minimum depths, average depths with tolerances, etc.

METHOD 301

EXPLOSION

1. Purpose. The explosion test is conducted to determine whether or not an electroexplosive subsystem or its components, will operate in the presence of a combustible mixture without creating an explosion or fire. This test shall apply to only the nonexplosive components of the electroexplosive subsystem.
2. Procedure. The electroexplosive system, or its component parts, shall be tested in accordance with MIL-STD-810, method 511.
3. Summary. The following details shall be specified in the individual specification:
 - a. Initial measurement
 - b. Final measurement.

MIL-STD-1512 (USAF)
21 March 1972

METHOD 302

LIGHTNING STRIKE INDUCED ENERGY

1. Purpose. This test is performed to demonstrate the adequacy of design protection from hazards of induced electrical energy in the grounding system from lightning strikes.

2. Procedure:

a. Electroexplosive subsystem shall be subjected to a peak simulated lightning induced transients of $\pm 1,800V$, with the following wave shape:

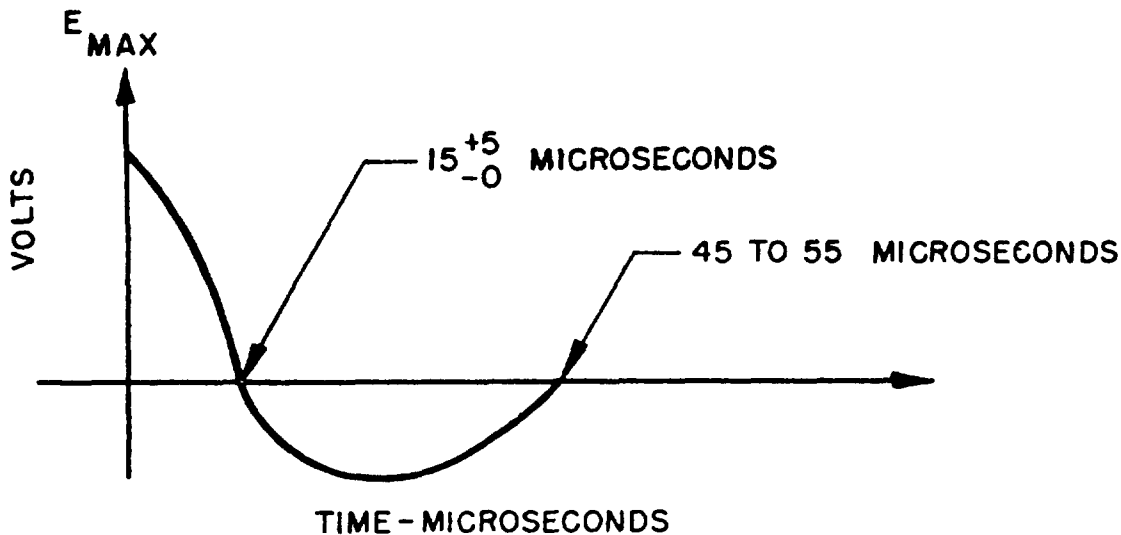

b. The method of applying the simulated lightning transient is shown in figure 302-1, and should be applied to the complete electroexplosive subsystem.

c. All terminals of the equipment to be tested shall be wired as used in the installation. In the test setup, the size of all interconnecting wires shall be as specified for the installation. The length of these wires shall be as short as possible, but shall not exceed 60 feet. The equipment shall be energized and operated.

d. Each equipment in the subsystem shall be individually tested by lifting the equipment grounding connection from case-to-structure and applying the transient between the subsystem ground and the equipment case.

MIL-STD-1512 (USAF)
21 March 1972

e. The values of C and R (figure 302-1) are adjusted to obtain the desired shape of the transient. The variable voltage supply is adjusted to a value such that the transient on the output terminals has the required amplitude.

f. Certain equipment may be protected by zener diodes, capacitive filters and other similar devices, which prevent the transient voltage from building up. For this reason and also to prevent the equipment from being subjected to undesirable transients, prior to applying the transient to the equipment, the transient shall be shaped on a 50-ohm noninductive resistor placed across terminals 1 and 2 of the transient source. When the desired amplitude and wave shape has been obtained, the 50-ohm resistor shall be removed and the transient source connected to the test setup as shown on figure and applied to the subsystem. Positive and negative transients are applied by interchanging the connections of terminals 1 and 2.

MIL-STD-1512 (USAF)
21 March 1972

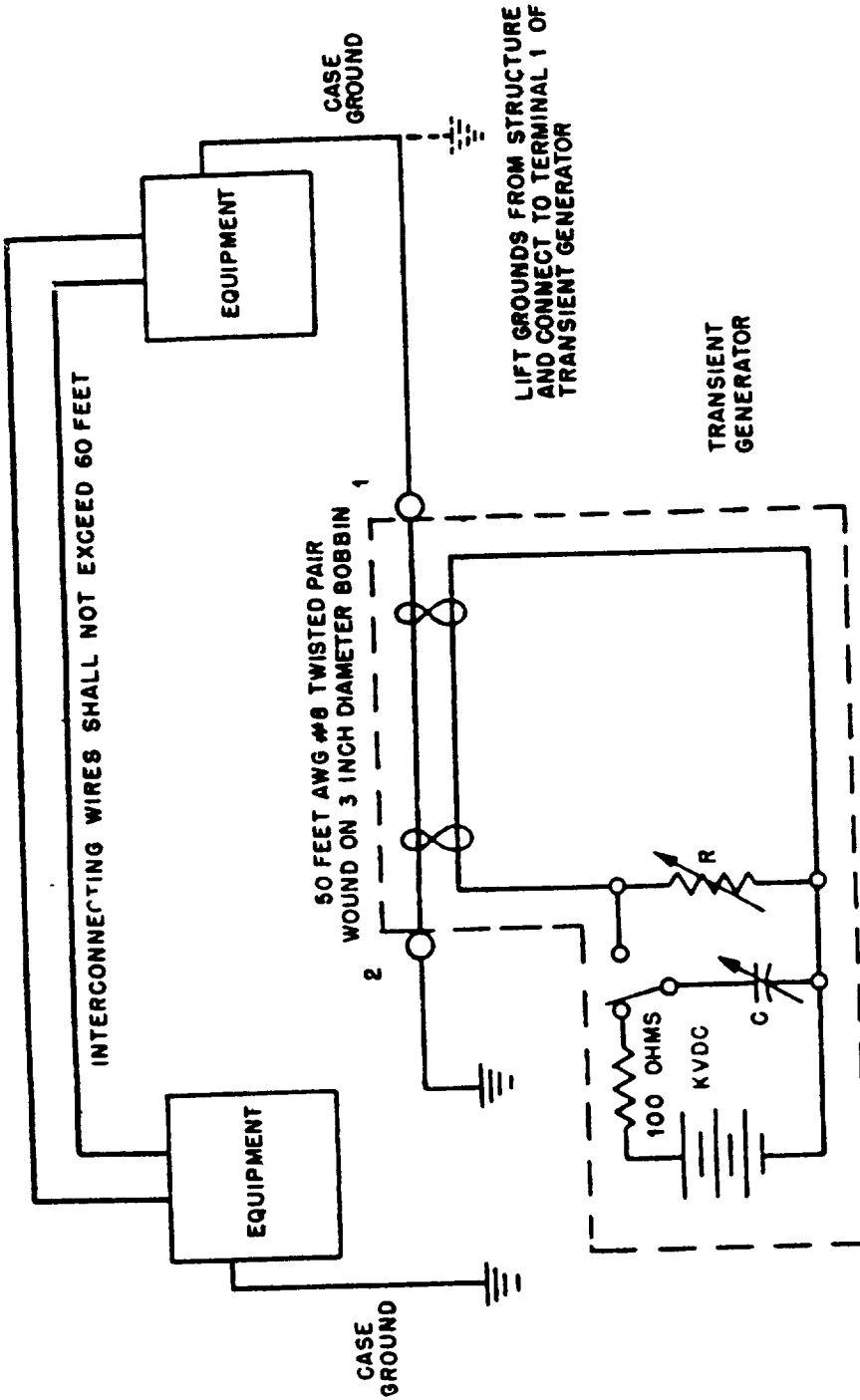

Figure 302-1. Method Of Applying Lightning Induced Transients

METHOD 303

ELECTROMAGNETIC ANALYSIS OF THE ELECTROEXPLOSIVE SUBSYSTEM

1. Purpose. The purpose of this method is to establish a uniform procedure for the analysis of the electromagnetic characteristics of the integrated electroexplosive subsystem.

2. Information required:

a. Electroexplosive devices:

- (1) Direct current sensitivity - method 203
- (2) Radio frequency impedance - method 204
- (3) Direct current susceptibility - method 208
- (4) Radio frequency sensitivity - method 207

b. Other electroexplosive subsystem components:

- (1) Shielding and radio frequency isolation data.

3. Procedure:

a. The maximum radio frequency sensitivity of the electroexplosive device to various modes of radio frequency coupling and the radio frequency protection provided by the other components and circuitry must be available.

b. Assume an ideal antenna(s) (based on design and safety data) and calculate the minimum radio frequency field intensity which could present a hazard to the electroexplosive subsystem involved. Compare this with the mission electromagnetic environment, if known. If the mission environment is not known, assume 195V per meter.

c. Examine possible receiving antennas associated with the electroexplosive subsystem. For instance, long unshielded leads might act as rhombic, loop, dipole or wire antennas, and be quite effective in absorbing radio frequency energy from the environment and transferring it to the electroexplosive device. Using design and safety data, and by examination of the electroexplosive device and connecting circuits used in the system, identify possible antenna configurations. Assume these to be ideal antennas

MIL-STD-1512 (USAF)
21 March 1972

having dimensions corresponding to the above configurations, and calculate their effective electrical length (effective height). Plot on semilogarithmic paper as a function of frequency, in decibels referenced to 1 meter.

d. Plot the mission electromagnetic environment, or the assumed 195V per meter, on semilogarithmic paper as a function of frequency, in decibels referenced to 1V per meter.

e. Determine the induced electromagnetic energy at each frequency by algebraically combining the plots from steps 3c and d. The results will be radio frequency voltage across the electroexplosive device in units of decibels referenced to 1V. Use the radio frequency impedance data from method 204 and calculate the induced radio frequency current through the electroexplosive device.

f. On suitable graph paper, plot the following data:

(1) The induced radio frequency current in the electroexplosive device calculated in step 3e

(2) The measured radio frequency susceptibility data from method 207.

g. Analyze the plot to determine the safety margin, or the additional radio frequency isolation required. If the calculated current is less than 0.1 percent (60 dB below), the measured radio frequency susceptibility current, then the electroexplosive subsystem is considered safe. (Since ideal and worst case conditions are assumed and the radio frequency losses in the electroexplosive subsystem cables and components are neglected, there will be an ample margin of safety.)

4. Note. This method is provided to obtain uniformity when such an analysis is used. It is preferred that emphasis be placed on actual system tests using stray energy detectors; however, when such tests are not feasible, this analysis is useful.

INSTRUCTIONS. In a continuing effort to make our standardization documents better, the DoD provides this form for use in submitting comments and suggestions for improvements. All users of military standardization documents are invited to provide suggestions. This form may be detached, folded along the lines indicated, taped along the loose edge (*DO NOT STAPLE*), and mailed. In block 5, be as specific as possible about particular problem areas such as wording which required interpretation, was too rigid, restrictive, loose, ambiguous, or was incompatible, and give proposed wording changes which would alleviate the problems. Enter in block 6 any remarks not related to a specific paragraph of the document. If block 7 is filled out, an acknowledgement will be mailed to you within 30 days to let you know that your comments were received and are being considered.

NOTE This form may not be used to request copies of documents, nor to request waivers, deviations, or clarification of specification requirements on current contracts. Comments submitted on this form do not constitute or imply authorization to waive any portion of the referenced document(s) or to amend contractual requirements.

(Fold along this line)

(Fold along this line)

DEPARTMENT OF THE AIR FORCE



NO POSTAGE
NECESSARY
IF MAILED
IN THE
UNITED STATES

OFFICIAL BUSINESS
PENALTY FOR PRIVATE USE \$300

BUSINESS REPLY MAIL
FIRST CLASS PERMIT NO 73236 WASHINGTON D C

POSTAGE WILL BE PAID BY THE DEPARTMENT OF THE AIR FORCE

ASD/ENESS
Wright-Patterson AFB, OH 45433

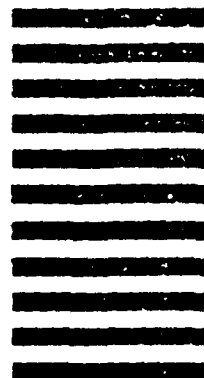

MILITARY STANDARD

ELECTROEXPLOSIVE SUBSYSTEMS, ELECTRICALLY INITIATED,
DESIGN REQUIREMENTS AND TEST METHODS

TO ALL HOLDERS OF MIL-STD-1512(USAF).

1. Add to Foreword: Explosive safety waivers. Certain requirements in this standard are mandatory to comply with provisions of AF Explosive Safety Directives, such as AFM 127-100. Requests for administrative waivers to change these directives must be forwarded to AF Inspection Safety Center, ATTN: SEOE, Norton AFB, Calif 92409 through Major Command explosive safety channels.
2. Add to paragraph 1.3.2 after second sentence: When the equipment is to be used at an Air Force launch or test facility, requests for deviation or waiver shall be coordinated with the appropriate launch or test facility.
3. Change paragraph 3.1.13 to read:
 - 3.1.13 Statistical test methods. Due to the one-shot nature of the electroexplosive initiator, verification of reliability and safety performance must be done on a sampling basis, using statistical test methods. The capabilities and limitations of several such statistical methods are discussed in DN 6A4 of AFSC DH 1-4. Further detailed information on the limitations of the Bruceton test method and the use of the log-logistic function in the Run Down test method is contained in NOLTR 63-133 (AD 426 466).
4. Change paragraph 5.11.1 to read:
 - 5.11.1 Type. All connectors used in the electroexplosive device shall be approved by the procuring activity and shall have a stainless steel shell or suitable conductive finish, complete the shield connection before the pins connect, and allow for continuous shield continuity.

MIL-STD-1512(USAF)

NOTICE 1

6 January 1976

5. The following pages of MIL-STD-1512 have been revised and supersede the pages listed:

<u>New Page</u>	<u>Date</u>	<u>Superseded Page</u>	<u>Date</u>
201-1	6 Jan 76	201-1	21 Mar 72
202-1	6 Jan 76	202-1	21 Mar 72

Custodian:
Air Force - 11

Preparing activity:
Air Force - 11

Reviewers:
Air Force - 10, 13, 15, 18, 19, 26, 70

Project No EMCS-F064

METHOD 201

BRIDGEWIRE RESISTANCE

1. Purpose. The purpose of this test is to measure the resistance of the bridgewire.

2. Procedure. Bridgewire resistance shall be measured applying a maximum current of 10 percent of the maximum no-fire current in the test circuit. An accuracy of at least 2 percent is required. In addition, pin-to-case resistances will be measured (on all electroexplosive devices where pin-to-case resistance differs from pin-to-pin resistance). The mean standard deviation, and 3 sigma deviation resistances shall be computed.

SUPERSEDES
METHOD 201
21 March 1972

201-1

METHOD 201
6 January 1976

MIL-STD-1512(USAF)
21 March 1972

METHOD 202

VERIFICATION OF 1 AMPERE/1 WATT CHARACTERISTICS

1. Purpose. The purpose of this test is to demonstrate the ability of the electroexplosive device to withstand a maximum energy dissipation without dudding or firing.
2. Procedure. This test shall be performed by applying to each bridgewire or set of pins for a minimum of 5 minutes, a dc voltage resulting in a dissipation of one watt or a current flow of 1 amp, whichever is greater.
 - a. The first 5 electroexplosive devices of the sample shall be tested. In the event that the no-fire current rating is less than 1 amp, apply the no-fire current for a minimum of five minutes. If the device fires, the no-fire level computed in method 203 is too high (a common shortcoming of extrapolating Bruceton data to extremes of the distribution) and a lower value should be tried. A 10 percent lower value should be selected and the process repeated until a satisfactory no-fire current level which can be endured for 5 minutes is selected. When the true no-fire 5 minute level is selected, the remainder of the first 5 units should be so exposed. These units should then be subjected to the all-fire current level (with firing anticipated) to ensure that the no-fire 5 minute test was not a cause for failure or dudding.
 - b. The objective of this test is to verify the 94.5 percent confidence level placed on the no-fire current initially estimated in method 203 and refined in 2a above. The true no-fire current level selected in 2a should be applied successively to 10 electroexplosive devices for 5 minutes each and none should fire, fail or dud. As in 2a, if a firing or failure occurs, the no-fire rating should be adjusted downward until 10 units can be successively tested without a failure. The no-fire level should be indicated on the function time plot generated in method 203.

METHOD 202
6 January 1976

202-1

SUPERSEDES
METHOD 202
21 March 1972