

MIL-F-18372(Aer)  
31 March 1955  
Superseding  
SR-169A  
1 July 1953

## MILITARY SPECIFICATION

### FLIGHT CONTROL SYSTEMS: DESIGN, INSTALLATION AND TEST OF, AIRCRAFT (GENERAL SPECIFICATION FOR)

This specification has been approved  
by the Bureau of Aeronautics, Department of the Navy

#### 1. SCOPE

1.1 Scope: This specification covers the general requirements for the design, installation, and test of flight control systems for all types of piloted aircraft contracted for by the U. S. Navy. (Power plant controls are excluded).

1.2 Classification: The flight control systems include:

PRIMARY FLIGHT CONTROLS - The controls for the actuation of, usually ailerons, rudders, elevators, rotor blades on helicopters, or other control surfaces performing similar functions.

SECONDARY FLIGHT CONTROLS -The controls for the actuation of trim tabs, adjustable stabilizers, and other surfaces or devices used for trimming the airplane.

FLIGHT PATH ANGLE AND SPEED CONTROLS -The controls for the actuation of high lift-drag surfaces.

1.2.1 Primary Controls: The controls for the actuation of the primary flight control systems may be of the following types: (Any type system not in these classification shall be discussed with the Bureau of Aeronautics during the preliminary design stages.)

Type I - Mechanical Flight Control System -A reversible control system wherein the pilot actuates the primary control surfaces of the aircraft through a set of mechanical linkages consisting of cable, pulleys, sectors and/or push-pull or torque tubes with horns, bellcranks, etc.

Type II - Power Boosted Flight Control System. - A reversible control system wherein the pilot effort, which is exerted through a set of mechanical linkages, is at some point in these linkages boosted by a power source.

Type III - Power Operated Flight Control System - An irreversible control system wherein the pilot, through a set of mechanical linkages, actuates a power control servo-mechanism, which mechanism actuates the main control surfaces of the aircraft.

1.2.2 Secondary Controls. - Controls for the actuation of the secondary flight control systems may, be of the following types:

MIL-F-18372(Aer)

Type I - Mechanical Control System - An irreversible control system wherein the pilot actuates the secondary control surfaces or devices of the aircraft through a set of mechanical linkages consisting of cables, pulleys, sectors and/or push-pull or torque tubes with horns, bellcranks, etc.

Type II - Power Operated Control System - An irreversible control system wherein the pilot actuates a switch which causes a power unit (electro-mechanical actuator or hydraulic control) to move the trim surfaces or devices.

1.2.3 Flight Path Angle and Speed Controls - Controls for the actuation of the flight path angle and speed controls systems may be of the following types:

Type I - Power Operated Control - A control system wherein the pilot actuates a switch or hydraulic control valve which causes a power unit (electro-mechanical or hydraulic) to move the flight path angle or speed control devices.

Type II - Automatic - A control system wherein the control surface is automatically actuated by the aerodynamic forces.

## 2. APPLICABLE DOCUMENTS

2.1 The following specifications, standards, drawings, and publications, of the issue in effect on the date of invitation for bids, forms a part of this specification.

### SPECIFICATIONS :

#### Military

MIL-B-7949 Bearing; Ball, Anti-Friction, Airframe  
MIL-B-6038 Bearing; Ball, Bellcrank, Anti-Friction, Airframe  
MIL-B-6039 Bearings; Ball, Rod End, Anti-Friction, Airframe  
MIL-B-5628 Bearings; Plain, Airframe  
MIL-B-5629 Bearings; Rod End, Plain, Airframe  
MIL-C-1511 Cable; Steel (Carbon), Flexible, Preformed  
MIL-C-5424 Cable; Steel (Corrosion Resistant), Flexible-Preformed (For Aeronautical Use)  
MIL-C-5688 Cable; Assemblies; Aircraft, Proof-Testing and Prestretching of  
MIL-C-5638 Casing; Control Cable Flexible, Aircraft  
MIL-F-8785(ASG) Flying Qualities of Piloted Airplanes  
MIL-A-8629(Aer) Airplane Strength and Rigidity  
MIL-H-8501 Helicopter Flying Qualities, Requirements for  
MIL-S-8698(ASG) Structural Design Requirements, Helicopters  
MIL-T-8679 Test Requirements-Ground, Helicopters  
MIL-H-5440 Hydraulic Systems; Design, Installation and Tests of Aircraft (General Specification For)  
MIL-J-6193 Joints; Universal, Plain, Light and Heavy Duty, Aircraft  
MIL-L-44380 Lubrication of Aircraft, General Specification For  
MIL-P-7034 Pulleys, Control, Anti-Friction Bearing, Grease-Lubricated Aircraft  
JAN-T-781 Terminal; Cable; Steel (For Swaging)  
MIL-T-6117 Terminal - Cable Assemblies; Swaged Type  
MIL-T-5685 Turnbuckles; Aircraft  
MIL-T-5522 Test Procedure For Aircraft Hydraulic System  
MIL-W-5013 Wheel and Brake Assemblies; Aircraft  
MIL-P-5518 Pneumatic Systems; Design, Installation and Tests in Aircraft

#### Bureau of Aeronautic

SD-24 General Specification for the Design and Construction of Airplanes for the United States Navy  
SR-6 Contract Design Data Requirements for Aircraft  
SR-38 Demonstration-of Piloted Airplanes  
SR-159 Stability and Control Calculations  
SR-189 Aerodynamic, Structural, and Power Plant Requirements for Helicopter.

STANDARDS:

MIL-STD-203 Cockpit Controls; Location and Actuation Of, For Aircraft

PUBLICATIONS .

Air Force - Navy Aeronautical Bulletins

ANA-275 Guide for Lubrication of Aircraft

(When requesting specifications, standards, drawings, and publications refer to both title and number. Copies of this specification and applicable specifications may be obtained upon application to the Commanding Officer, U. S. Naval Air Station, Johnsville, Pennsylvania, Attention Technical Records Division)

3. REQUIREMENTS

3.1 Desire and Installation Requirements for All Aircraft Types

3.1.1 Requirements That Apply to All Classes of Flight Controls

3.1.1.1 General - Flight control systems shall be as simple, direct and foolproof as possible with respect to design, operation, inspection and maintenance. Early and careful consideration shall be given the new designs to the arrangement of cables and other connecting elements that extend from the cockpit to the control surfaces so as to effect the most direct and simple routing possible. The number of bends or changes in direction shall be held to a minimum. All practicable compromises in the installation of equipment shall be the to favor the most direct control system possible. Workmanship shall be of sufficiently high grade throughout to insure proper operation and adequate service life. The strength of the flight control system shall be in accordance with Specification MIL-A-8629(Aer).

3.1.1.1.1 Power Operated Systems - Failure of any or all the engines in flight shall not result in the pilot being unable to operate those powered services which are essential to the making of a safe descent from altitude and an emergency landing.

3.1.1.1.2 Reserve Power for Emergency Use - An independent source of power shall be provided to operate those powered services vital to the safe descent and landing of the airplane, which would otherwise be put out of action by failure of any or all of the engines of the aircraft.

3.1.1.2 Pilot's Controls -

3.1.1.2.1 Location and actuation - The location and actuation of the pilot's controls shall be in accordance with MIL-STD-203.

3.1.1.2.2 Stops - Stops shall be provided to limit the controls in the cockpit to the desired motion ranges. The stops shall be located as near the control in the cockpit as possible. (See paragraph 3.1.1.21 for requirements regarding surface stops).

3.1.1.2.3 Removable Controls - Components provided with a disconnect feature for removal shall be so designed as to prevent incorrect installation.

3.1.1.3 Structural Deflection - Deflection of the aircraft structure in flight shall not result in excessive loss of cable rigging tension or in a change in position of any aerodynamic surface unless such change is determined to be necessary and/or desirable for the purpose of improving the stability and control characteristics of the aircraft.

3.1.1.4 Rigidity - The rigidity of the flight control systems shall be sufficient to provide satisfactory operation and to enable the aircraft to meet its stability, control and flutter requirements. Individual components shall be sufficiently rigid to withstand normal handling and servicing and shall not become adversely deformed under operating loads or airframe structural deflections.

3.1.1.5 Acceleration Effect - Acceleration forces acting upon the control system's components shall not result in forces at the pilot's control unless such forces are determined to be necessary and/or desirable for the purpose of improving the handling qualities of the aircraft.

3.1.1.5.1 Effect of Acceleration on Type II and Type III Systems - Acceleration forces acting upon hydraulic, pneumatic or electro-mechanical system components shall not affect the functioning of the normal or emergency systems. Consideration shall be given to the fluid column used in hydraulic systems.

3.1.1.6 Vulnerability - Consideration shall be given to the spacing and arrangement of the flight control systems to reduce the vulnerability of the systems to the minimum value practicable. Also, advantage shall be taken, wherever possible, of the shielding afforded by heavy structural members or existing armor plate installation for the protection of the control systems, particularly in places such as points of cable convergence, horns, bellcranks, main sheaves and walking beams.

3.1.1.7 Fouling Prevention - All elements of the control system, subject to fouling by loose gear, shall be suitably protected or covered. Consideration shall be given to the protection of control elements subject to fouling due to ice formation.

3.1.1.8 Clearances - All moving parts of a control system shall have sufficient clearance with each other and with other parts of the aircraft to prevent fouling under all operating conditions. Consideration shall be given to the effect of tolerances in manufacture, assembly, installation, rigging, normal wear and normal deflection.

3.1.1.9 Temperature - Flight control systems shall be designed for operation at temperatures between 160°F (+71°C) and -65°F (54°C). However, if it is anticipated that these temperature limits will be exceeded, components for the control system shall be selected or designed to operate at the anticipated temperature.

3.1.1.10 Accessibility - All parts of the flight control systems shall be readily accessible for inspection, repair, adjustment of linkages and components, and for lubrication. Inspection doors shall be provided at pulleys, quadrants, connections and components, not otherwise readily accessible. It shall be possible to inspect the entire length of cables and push-pull rods for corrosion and signs of wear periodically without disconnecting the systems.

3.1.1.11 Drainage - Adequate provisions shall be made to drain control system components subject to accumulation of moisture.

#### 3.1.1.12 Bearings

3.1.1.12.1 Anti-Friction - Approved type, AN airframe, ball bearings shall be used throughout the flight control system, except as indicated below. In the event design limitations do not permit the use of ball bearings, prelubricated shielded roller or needle bearings may be used. Where roller or needle bearings are used, consideration shall be given relubrication provisions. The inner race of the bearing shall be clamped to prevent rotation of the Inner race with respect to the pivot bolt. Bearing installations shall be arranged in such a manner that failure of the rollers or balls will not result in a complete separation of the control. Direct axial application of control forces to a bearing shall be avoided if possible. In the event such an arrangement is necessary, a fail safe feature shall be provided.

3.1.1.12.2 Spherical Bearings -Where design limitations preclude the use of anti-friction bearings, spherical type plain bearings approved by the Bureau of Aeronautics may be used. When used, spherical type bearings shall have adequate provisions for relubrication.

3.1.1.12.3 Journal - Plain type journal bearings shall be avoided. However, where substantiated, and where play and friction are not major considerations, journal or plain bearings, with adequate and accessible provisions for lubrication, may be used.

3.1.1.12.4 Sintered - Sintered type or oil impregnated bearings shall not be used in those part of the flight control systems which have slow moving or oscillating motions. Fast moving rotating application such as in qualified motors and actuators are considered satisfactory.

3.1.1.12.5 Self-Alignment - Self aligning bearings shall be used wherever necessary to eliminate the possibility of binding or excessive wear due to misalignment of connecting parts.

3.1.1.13 Horns and Brackets - All horns and brackets shall be designed and attached so that they can be readily replaced in service.

3.1.1.14 Shock Absorber Cords - Shock absorber cords shall not be used in flight control systems.

3.1.1.15 Chains - Chains shall not be used in flight control systems.

3.1.1.16 Fastenings - In general, fastenings shall be in accordance with SD-24 with the following amplifications: Clevis pins shall not be used. Clevis bolts with shear castle nuts and cotter pins are considered satisfactory in shear applications. Self locking type nuts shall not be used at single attachments or where loss of the bolt would affect safety of flight. Bolts mounted upside down in single attachments shall have the head lockwired to prevent loss of bolt in the event the nut is loose. Bolts less than  $\frac{1}{4}$  dia. shall not be used in any single attachment in the primary flight control systems or in any application on all flight controls or associated systems where loss of a bolt would affect the safety of the flight control systems. Provisions shall be made to prevent jamming, bending or failure of the components in the flight control systems due to possible excessive over-torque being applied to the attaching bolts and nuts. Written or printed warnings in the service handbooks, drawings, placards, etc., to prevent bolts from being over-torqued are not considered provisions to meet this requirement.

#### 3.1.1.17 Cable Systems

3.1.1.17.1 Cables - Control cables shall conform to the applicable specifications. Carbon steel cable shall be used except where corrosion factors preclude the use of the carbon steel cable in which case, corrosion-resistant steel cable shall be used.

3.1.1.17.2 Kinematics - The kinematics of the components in the cable systems shall be such as to prevent an objectionable amount of change in cable tension throughout their flight and ground operational range.

3.1.1.17.3 Tension of Cable Systems - Wherever necessary, provisions shall be made to prevent excessive variation of cable tensions due to temperature changes. Consideration shall be given to the effect of heat from local areas such as engine nacelles, cabins, heat deicers, etc., which may cause temperature rises in an adjacent portion of a control system while the aircraft structure proper remains at the ambient air temperature.

In the interest of reducing control system friction, initial tensions should be held to the lowest practicable values that provide safe and satisfactory operation considering probable application of limit loads to the system and the effect of temperature changes.

3.1.1.17.4 Attachments - Terminals, disconnect fittings, turnbuckles, etc., shall be provided as necessary to facilitate rigging and maintenance of the control system.

3.1.1.17.5 Location of Attachments - Cable attachments shall be located in such a manner that it is impossible to cross connect cables during installation. Cable attachments shall be located in such a manner that it is impossible for them to jam or hang up on adjoining structure or other fittings.

3.1.1.17.6 Terminals - Terminals shall be of the swaged type and shall conform to the applicable specifications. Ball type swaged terminals shall not be used in primary control systems except for attaching cables to quadrants where standard fork and eye fittings are not adaptable. Ball type swaged terminals shall not be used with strap fitting as a substitute for standard fork and eye fittings. All cable assemblies fabricated with swaged terminals, shall be proof-loaded, in accordance with the applicable specification.

3.1.1.17.7 Cable Turn Radius - The ratio of sheave (pulleys, drums, sectors, etc.,) diameter to cable diameter shall not be less than the following values: (where the cable load is the maximum load expected in the cable under normal operating conditions.)

<u>Cable Load in % Specified Cable Breaking Strength</u>	<u>Sheave Ratio</u>
1	10
10	20
20	28

Cables shall not be subjected to critical bends at the junction with cable terminals or other attaching points such as drums, horns, etc.

3.1.1.17.8 Cable Alignment - Cables shall not be misaligned with sheaves in excess of the following values: (The alignment of a cable with its pulley is defined as the angle between the center line of the cable and the plane of the pulley.)

(a) Primary flight controls - Not over 10, except where AN219, AN220, or AN221 pulleys are used, or where side travel of the cable exists, and then not over 20.

(b) All other controls - Not over 20, except where AN219, AN220, or AN221 pulleys are used, or where side travel of the cable exists, and then not over 3°.

3.1.1.17.9 Turnbuckles - Turnbuckle terminals shall not have more than three (3) threads exposed at either end. All turnbuckle assemblies shall be properly safetied.

3.1.1.17.10 Take-Up Links - Vernier links shall be provided, where necessary, to facilitate proper rigging of the cable systems.

3.1.1.17.11 Pulleys and Sheaves - Pulleys shall be of adequate capacity and diameter for the size of cables and loads. Anti-friction bearing pulleys shall be used in all flight controls.

3.1.1.17.12 Drums, Sectors, and Quadrants - All cables shall be positively attached to driven or driving drums, sectors, etc. Drum, sectors, or quadrants shall have at least 100 wrap of the the driving cable after the limits of its range of movement in both directions have been reached.

3.1.1.17.13 Guards - Guards shall be installed at all sheaves (pulleys, sectors, etc.,) to prevent the cable from jumping out of the groove of the sheave. Guards shall be installed at the approximate point of tangency of the cable to the sheave and where the cable wrap exceeds 90°, one or more intermediate guards shall be installed. To prevent binding of the of the sheave due to relative deflections in the airplane structure, all guards shall be supported by the supporting brackets of the parts which they guard. Additional guards shall be installed on sectors at the point of entry of the cable into the groove from its attachment. The design of the rubbing edges and selection of materials shall be such as to minimize cable wear and prevent jamming, even when the cable is slack.

3.1.1.17.14 Fairleads - Fairleads shall be used wherever necessary to keep cables from chafing and slapping against parts of the aircraft. Fairleads shall not cause any angular change in the cable. They shall be of non-hygroscopic, non-abrasive material. Fairleads shall be split to permit easy removal, unless the hole in the fairlead is of sufficient size to permit the cable with the swaged terminals attached to be threaded through. Where space permits the fairleads should clear the primary flight control cables by a minimum of ¼". The cables may rest against the lower edge of the hole in the fairleads on long straight runs where the cable would normally sag due to their own weight even when properly rigged.

3.1.1.17.15 Clearance - All control cables shall have a minimum of ½" inch clearance with all wiring, tubing, and removable equipment (exclusive of the basic airframe structure). Clearances of less than ½" are permitted between the cables and the basic airframe structure provided suitable fairleads are installed.

3.1.1.18 Push-Pull Systems

3.1.1.18.1 Adjustable Terminals - Adjustable terminals shall be arranged so that there will be no possibility of a terminal becoming inadvertently detached. Adjustment shall be possible at one end only for any single tube. Where one adjustable rod end is made fixed as a means of preventing the rod from becoming detached, rivets or bolts through the threaded shank shall not be used with threaded ends

less than 7/16 dia. Male shank type rod end bearings are preferred over female types.

3.1.1.18.2 Supports - All push-pull tubes shall be supported by suitable levers, bellcranks, or rollers. To prevent possible binding of the system due to misalignment or deflection, self-aligning anti-friction bearings shall be used in all terminals. Suitable precautions shall be taken to prevent jamming or undesirable wear of parts resulting from rotation of the tube about its axis.

3.1.1.18.3 Tubes - Tubes shall have a minimum wall thickness of .035 inch and shall be seamless except that steel tubes, seam-welded by the electrical resistance method, may be used. Consideration shall be given to the natural frequency of vibration of the tubes with respect to the vibrations set up in the aircraft.

3.1.1.18.4 Flexible Controls - Flexible push-pull type controls shall not be used.

#### 3.1.1.19 Torque Systems

3.1.1.19.1 Slip Joints - All torque control systems shall incorporate splined joints or equivalent, as necessary, to prevent binding of the system due to deflections of the aircraft structure.

3.1.1.19.2 Supports - All torque tubes shall be mounted on anti-friction (preferably self-aligning) bearings.

3.1.1.19.3 Tubes - Tubes shall have a minimum wall thickness of .035 inch and shall be seamless, except that steel tubes seam-welded by the electrical resistance method, may be used. Consideration shall be given to the natural frequency of vibration of the tubes with respect to vibrations set up in the aircraft.

3.1.1.19.4 Universals - All torque tube control systems shall incorporate universals as necessary to prevent binding of the systems due to misalignment of supports or deflection of the aircraft structure.

3.1.1.20 Differential Controls - A control system in which differential motion is obtained shall incorporate stops to prevent the cranks from reaching a locking or reversing position unless specifically required for the proper operation of the system.

3.1.1.21 Control Surface Stops - In aircraft, such as VP and VR types, employing large, heavy surfaces, stops shall be provided at each surface.

3.1.1.22 Adjustable Stops - All adjustable stops shall be positively locked or safety wired in the adjusted position. Jam nuts (plain or self locking type) are not considered adequate as locking devices for this application.

3.1.1.23 Stability Augmenting Devices - Devices installed for the purpose of augmenting stability shall be so designed that the failure of such a device will not cause discontinuity of the flight control system or any other flight hazard. The system shall be designed so that, under normal operating conditions, there is no adverse reflection on the pilot's primary controls.

3.1.1.24 Other Devices - Other devices such as spring bungees tension regulators, bob weights, dampers, etc., shall be so designed that their failure shall not cause discontinuity of the control system, or any other flight hazard. Positive locks or safety wire shall be provided at all attachment, where there is a possibility of the components in spring cartridge, dampers, etc., becoming detached as a result of inadvertent rotation of the components.

#### 3.1.2 Additional Requirements For Primary Flight Controls

3.1.2.1 Type I System - In the design of flight control systems the reliability, strength, and simplicity of the system shall be of paramount consideration. Whenever push-pull tube systems are used they shall be so arranged that all the tubes are in tension for the greater load for which the

system is designed. When the cable type control system is used, a single system cable may be used for lateral and directional controls. However, positive independent control of the lateral control surfaces on each side, in both directions, shall be provided to insure control in the event of failure of the controls on one side.

3.1.2.2 Type II Control Systems - The mechanical portions of the Type II control system shall meet the requirements set forth for the Type I control system. The power system for the Type II control system, if hydraulic, shall be completely independent and shall have no interconnection with any other hydraulic system, and if electrical, it shall, except for the power source, have no interconnection with any other electrical system.

3.1.2.2.1 Power System Failure - When a failure occurs in the power system of a Type II control system, regardless of the type of failure, it shall be possible to operate the flight controls directly through the mechanical system within the limitations set forth in the contract requirements. Where a mechanical advantage change device is incorporated, no hazardous lag shall exist during the change over.

3.1.2.3 Type III Control Systems - The mechanical portions of the Type III system shall meet the requirements set forth for the Type I control system. The power systems for the Type III control system, if hydraulic, shall be completely independent, and shall have no interconnection with any other hydraulic system, and if electrical, it shall, except for the power source, have no interconnection with any other electrical system. Consideration shall be given for the utilization of separate systems, that are completely independent of each other, for powering the controls about each axis, unless it can be proven that simultaneous loss of control about any two axes or all three axes is no more detrimental to the aircraft than loss of control about any one axis.

3.1.2.3.1 Single Power Control System - A single power system may be employed where an emergency manual system is available. When a failure occurs in a single power system it shall be possible to operate the flight controls through a direct set of mechanical linkages to obtain aircraft controllability within the limitations set forth in the contract requirements. Where a mechanical advantage change device is incorporated, no hazardous lag shall exist during the changeover. On rotary wing aircraft it is preferred that the power source be rotor driven.

3.1.2.3.2 Dual Power Control System - A dual power system shall consist of two completely independent single systems both operating simultaneously. Each system shall be an exact duplicate of the opposite system, as simple as practicable, and contain a minimum number of components. There shall be no interconnections between the two systems. When hydraulic, the power sources shall be from two (2) engine driven pumps on single engine aircraft. In multi-engine aircraft the power sources shall be from separate engines. For rotary winged aircraft, at least one power source shall be rotor driven regardless of whether the aircraft is single or multi-engined. Tandem or parallel cylinder in the same housing are conceded satisfactory for dual power control systems.

3.1.2.3.2.1 Dual System Failure - When one system of a dual system fails, the performance requirements of the aircraft, with a single system in operation, shall meet the contract requirements.

3.1.2.4 System Indicators -

3.1.2.4.1 Type II Systems - If applicable, an indicator shall be provided to warn the pilot of a power system failure, if practicable, prior to complete loss of the power boost system.

3.1.2.4.2 Type III Systems - In Type III systems an indicator shall be provided which will inform the pilot that both systems are functioning normally. In addition, the indicator shall be of such a design as to indicate to the pilot, if practicable, a failure of either or both systems prior to complete loss of the system.

3.1.2.5 Artificial Feel Devices - The artificial feel system shall provide a force gradient which will permit the aircraft to meet its contract requirements. Any failures in the system shall not result in control forces that are either so high or so low as to be hazardous.

3.1.2.6 Power Control Override Provisions - Provisions shall be made to permit direct pilot effort to be applied to a control valve in the event the valve becomes jammed or frozen. In other words any spring or load relieving device between the pilot and the valve, which is designed to prevent excessive loads being applied to the valve, shall become a solid link before full pilot control travel is reached.

### 3.1.5 Additional Requirements For Secondary Flight Control

3.1.3.1 Manually Operated Trim Control System - When manually operated trim control systems are used, it shall be possible to obtain the necessary control with a minimum amount of input motion consistent with acceptable operating forces.

3.1.3.2 Power Operated Trim Control Systems - Where power units are provided for operating the trim surfaces or devices, even where more than one speed is provided, the rate, or rates, of application shall be such that preciseness of control is obtained for landing, take-off and in-flight conditions without creating a hazard.

3.1.3.2.1 Emergency Systems - Where failure of a power operated trim control system would result in marginal or undesirable control characteristics, a completely separated emergency power system, or means to override the failed power system, shall be provided.

3.1.3.3 Irreversibility - The control system for each trimming surface or device shall be irreversible, and shall maintain a given setting until changed by the pilot. It is desired that the irreversible mechanism be as near to the trim tab, or trimming device, as is practicable, preferably in the linkage which connects to the tab horn, to minimize free play at the surface and maintain rigidity in the control.

3.1.3.4 Synchronization - Where two (2) controllable trim surfaces are used on the elevators, they shall be mechanically interconnected.

3.1.3.5 Pilot's Controls - The location and actuation of the pilot's controls shall be in accordance with MIL-STD-203. Controls shall be clearly marked to indicate their purpose and direction of motion.

3.1.3.5.1 Position Indicator - Suitable indicators shall be provided to indicate the neutral position and the range of travel of each trim device. Where movable surfaces are used for trimming, the sensing devices for the indicator shall be operated by the surface or a mechanical link directly connected to the surface. A position sensing device is not required on the surface if the system is entirely manual, unless an electrical instrument type indicator is used. On manual type systems a mechanical type indicator on or near the cockpit control is considered satisfactory.

### 3.2 Additional Design And Installation Requirements For Fixed Wing Aircraft

#### 3.2.1 Primary Flight Controls

3.2.1.1 Friction - The requirements relative to friction in the primary flight control systems, shall be in accordance with the contract requirements.

#### 3.2.1.2 Pilot's Controls

3.2.1.2.1 Longitudinal - Longitudinal controls shall be by means of a stick, or wheel. Forward movement of the stick or wheel shall cause the aircraft to nose down, and aft movement shall cause the aircraft to nose up. The range of movement of the longitudinal control shall be a maximum of 14". The extreme aft position shall be not more than 9" from the neutral position.

3.2.1.2.2 Lateral - The lateral control shall be by means of a stick or wheel. Movement of the stick to the right, or clock-wise rotation of the wheel, shall cause the aircraft to roll to the right; movement of the stick to the left, or counter-clockwise rotation of the wheel, shall cause the aircraft to roll to the left. The range of movement of the lateral control stick shall be a maximum of 7" to the right and 7" to the left of the neutral position. The rotation of the control wheel shall be a maximum of 110° clock-wise and 110° counter-clockwise.

### 3.2.1.2.3 Stick and Wheel Requirements

3.2.1.2.3.1 Control Stick - If a control stick is used, and is removable, it shall be positively latched in place when installed. It shall be possible to install the stick only in the correct manner, and suitable means shall be provided to prevent rotation of the stick.

3.2.1.2.3.2 Control Wheel - Control wheels shall be constructed of a material of adequate strength and durability, and shall be designed to have a minimum of sight interference with the instrument panel.

3.2.1.2.4 Directional Control - Directional control shall be by means of foot pedals. Pushing the right pedal shall cause the aircraft to turn to the right. Pushing the left pedal shall cause the aircraft to turn to the left. The range of movement of the foot pedals shall be a maximum of 4" forward and 4" aft of the neutral position. The foot pedals shall be interconnected to insure positive movement of each pedal in both directions.

3.2.1.2.4.1 Adjustment - The foot pedals shall be readily adjustable in flight to at least 3" forward and 3" aft of neutral, in increments not exceeding 1". Both pedals shall be adjusted simultaneously by means of a single control, and the control shall be located in accordance with MIL-STD-203.

3.2.2 Wheel Brakes Control - Rights and left brakes shall be separately actuated by toe force on brake pedals on the rudder controls except for bicycle gear or quadricycle gear, where other suitable brake controls may be used subject to approval of the Bureau of Aeronautics. Pedal locations in the cockpit shall be in accordance with MIL-STD-203. The brake pedal linkages shall be so designed that a comfortable angle of approximately 90° between the pilot's foot and his lower leg is maintained throughout the full range of movement of the rudder pedals and seat. The desired shape and travel of the brake pedals are shown in Figures 1 and 2 respectively. Linkages between the brake pedals and the brake control device shall be as free as possible of lost motion or yielding of parts. Means shall be provided to positively return the brake pedals to the "off" position when toe force is removed from the pedals.

3.2.2.1 Manual Braking Systems - The pedal linkages for manual braking systems shall be such that :

- a. A foot force of between 15 and 20 pounds at the tip of the pedal will be required to cause initial movement of the brake pedal.
- b. A foot force of between 75 and 125 pounds at the tip of the pedal will produce the braking deceleration specified in Specification MIL-W-5013 at the normal landing gross weight.
- c. The travel of the pedal for full brake application shall be as indicated in Figure 2. It shall not exceed 300 while meeting the requirements of subparagraph b above.
- d. In all positions of the rudder pedal or the rudder linkage, and the seat it shall be possible for the pilot to apply sufficient static brake torque to hold the wheels locked against a coefficient of friction of 0.55 between the tires and the ground at maximum alternate weight. It shall be possible to meet this requirement with the brakes at a temperature of 21°C (70°F).

3.2.2.2 Power Braking System - The pedal linkages for power braking systems shall be such that :

- a. A foot force of between 15 and 20 pounds at the tip of the pedal will be required to cause initial metering through the power brake valve.
- b. A foot force of between 65 and 85 pounds at the tip of the pedal will produce the braking deceleration specified in Specification MIL-W-5013 at the normal landing gross weight.

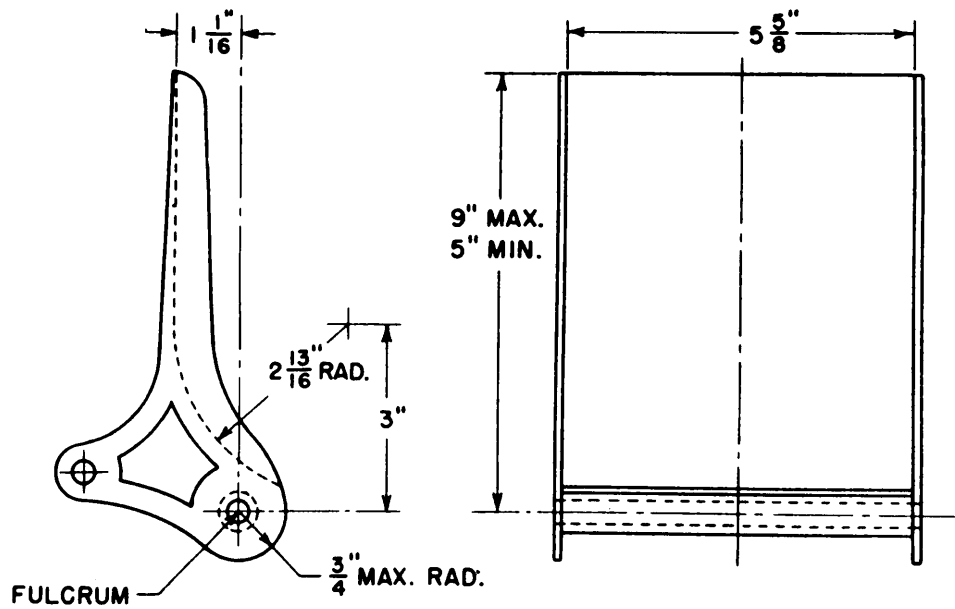

**NOTE:**

ADEQUATE PROVISION SHALL BE MADE TO PREVENT THE PILOT'S FOOT FROM SLIPPING OFF OR THROUGH THE PEDAL.

FIGURE 1 BRAKE PEDAL SHAPE

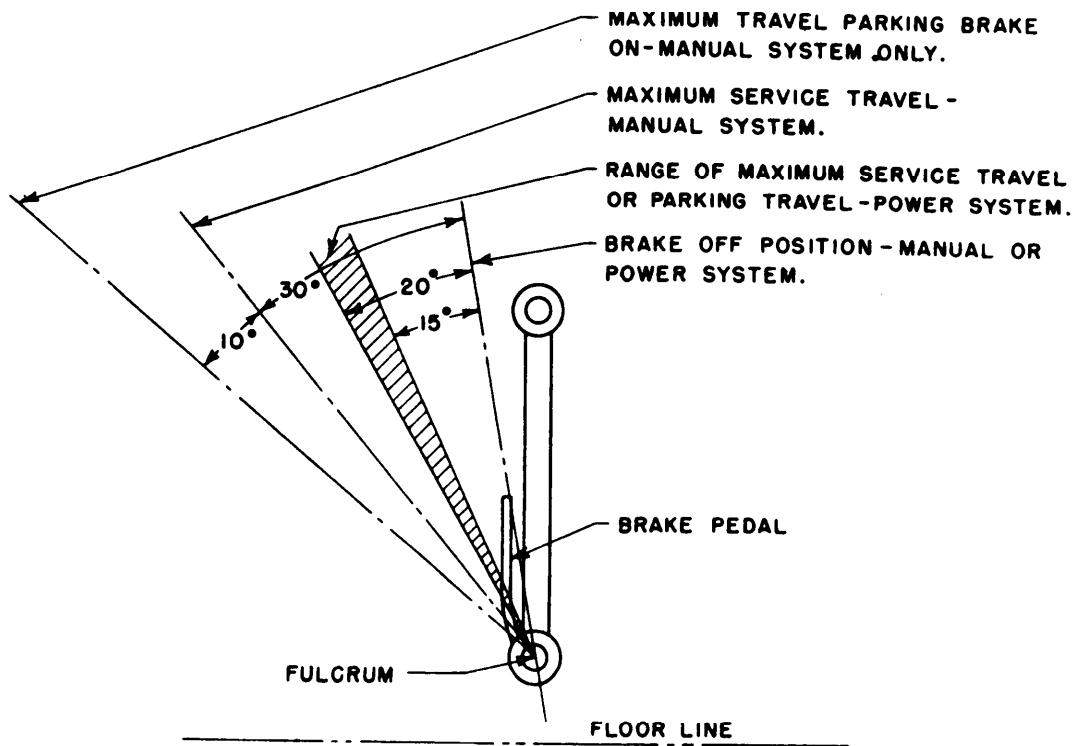

FIGURE 2 BRAKE PEDAL TRAVEL

- c. Brake pressure sufficient to hold the wheels locked shall be available at all positions of the rudder pedal or rudder linkage and the seat assuming a coefficient of friction of 0.55 between the tires and the ground at the maximum alternate weight. It shall be possible to meet this condition with the brakes at a temperature of 21°C (70°).
- d. The travel of the pedal shall be as indicated in Figure 2. It shall be between 15 and 20° to meet the requirements of subparagraph b above.

3.2.2.3 Emergency Brake Control - The location and actuation of the emergency brake control shall be as indicated in MIL-STD-203.

3.2.2.4 Parking Brake Control - The location and actuation of the parking brake control shall be as indicated in MIL-STD-203.

3.2.3 Control Surface Locks - Locks shall be provided for all primary control surfaces, other than those which are actuated by irreversible control systems, to lock the surfaces in neutral, when the airplane is parked. If built-in locks are incorporated, they shall either engage the surfaces directly, or lock the controls as near to each surface as practicable. These locks shall be so arranged that they cannot be engaged during flight for any reason, such as inadvertent operation of the cockpit control lever, relative deflections between the lock control system and the aircraft, component failure, combat damage, etc.

3.2.3.1 Pilot's Control - The pilot's control for the surface locks shall be so arranged as to make it impossible for the pilot to take off with the locks engaged. Means shall also be provided to lock the pilot's control in the unlock position.

3.2.3.1.1 Locking Range - The range of movement of the pilot's control and lock control system shall be sufficient to insure complete locking or unlocking of the control surface under the most adverse conditions of structural and system deflections. In unlocking the surface locks, a maximum of 50% of the range of motion of the pilot's control shall directly and positively unlock the control surfaces. This means the first 50% of the range.

#### 3.2.4 Flight Path Angle and Speed Controls

3.2.4.1 High Lift Controls - A suitable control system shall be provided for actuating the non-automatic high lift devices (flaps, slats, etc)

3.2.4.1.1 Emergency Operation - An emergency means for operating the high lift devices shall be provided on aircraft, where safe operational landings cannot be accomplished without use of the high lift device. The emergency system shall be completely independent of the primary system up to, but not necessarily including, the actuator.

3.2.4.1.2 Operating Time - At the maximum limiting aircraft speed for which the device may be operated, the time of operation for power operated landing flaps shall be as follows:

<u>TYPE OF AIRCRAFT</u>	<u>TIME TO COMPLETELY EXTEND</u>	<u>TIME TO COMPLETELY RETRACT</u>
VP, VR, vu	Not less than three (3) seconds Not more than twelve (12) seconds	Not less than five (5) seconds Not more than twelve (12) seconds
All Others	Not less than three (3) seconds Not more than eight (8) seconds	Not less than three (3) seconds Not more than eight (8) seconds

3.2.4.1.3 Synchroization - High lift devices shall be mechanically interconnected, unless it can be demonstrated that no hazardous flight attitude will result from unsynchronized operation. In the event of a failure of the high lift control system actuators, such as a screw jack, hydraulic cylinder, etc., the high lift device shall maintain synchronization, or remain synchronized without motion.

3.2.4.1.4 Indicator - An approved type indicator shall be provided in the cockpit to indicate flap positions.

3.2.4.2 Speed Brake Controls - A suitable control system shall be provided for actuating the speed brakes. The speed brake control system must be capable of withstanding frequent operation at all flight speeds up to the terminal velocity of the airplane.

3.2.4.2.1 Emergency Ststems - Emergency retraction is required on those speed brakes that will not automatically retract, as a result of air loads, when the control is moved to the retract position.

3.2.4.2.2 Positioning - The speed brake control system shall be of such design as to permit infinite variable positioning.

3.2.4.2.3 Operating Time - It shall be possible to completely extend the speed brakes in not less than two (2) seconds and not more than three (3) seconds. Time of operation specified shall apply at  $V_{at}$  sea level and at all ambient air temperatures between  $-20^{\circ}\text{F}$  ( $-29^{\circ}\text{C}$ ) and  $+120^{\circ}\text{F}$  ( $+49^{\circ}\text{C}$ ). Between  $-20^{\circ}\text{F}$  ( $-4^{\circ}\text{C}$ ) and  $-65^{\circ}\text{F}$  ( $-54^{\circ}\text{C}$ ), and between  $+120^{\circ}\text{F}$  ( $+49^{\circ}\text{C}$ ) and  $+160^{\circ}\text{F}$  ( $+72^{\circ}\text{C}$ ), the time of operation shall not exceed  $4\frac{1}{2}$  seconds. The above values shall be met with all components of the actuating mechanism stabilized at the extreme temperature, and without assuming time for warm-up of the components.

3.2.4.2.4 Location of Control - The pilot's control for the speed brake shall be located in accordance with MIL-STD-203.

3.2.4.2.5 Actuation - The pilot's actuating mechanism shall be a three-position device with a stop position in neutral, momentary aft position to extend, and a maintained forward position for retraction.

3.2.4.2.6 Indicator - An indicator shall be provided to indicate whether speed brakes are extended.

### 3.3 Additional Design and Installation Requirements for Rotary Wing Aircraft

#### 3.3.1 Primary Controls

3.3.1.1 Cyclic Pitch Controls - The cyclic pitch control shall be by means of a stick. Movement of the stick forward shall direct the resultant rotor thrust in the forward direction; movement of the stick aft shall direct the resultant rotor thrust in the aft direction; movement of the stick to the right shall direct the resultant rotor thrust to the right; and movement of the stick to the left shall direct the resultant rotor thrust to the left. The range of movement of the cyclic pitch control shall not be more than 14 inches in the fore and aft direction, with a maximum of 9 inches aft of the neutral position, and not more than 7 inches to the right, and 7 inches to the left, of the neutral position. If the control stick is removable it shall be positively latched in place when installed. It shall be possible to install the stick only in the correct manner, and suitable means shall be provided to prevent rotation of the stick.

3.3.1.2 Collective Pitch Control - The collective pitch control shall be by means of a lever. Movement of the lever in an upward direction shall increase the resultant rotor thrust, and movement of the lever in a downward direction shall decrease the rotor thrust.

3.3.1.2.1 Throttle Interconnection - The collective pitch control shall be interconnected with the throttle control, and synchronized to provide the proper throttle setting as collective pitch is increased or decreased. Means shall also be provided to permit throttle control independent of lever movement, by rotation of the grip on the lever.

3.3.1.2.2 Locks - An adjustable friction type lock, or equivalent, shall be provided to retain the collective pitch lever in any desired position. A lock shall also be provided to lock the collective pitch lever in the down position.

3.3.1.3 Directional Control - Directional control shall be by means of foot pedals. Pushing the right pedal shall cause the aircraft to rotate to the right. Pushing the left pedal shall cause the aircraft to rotate to the left. The range of movement of the foot pedals shall be a maximum of 4" forward and 4" aft of the neutral position. The foot pedals shall be interconnected to insure positive movement of each pedal in both directions.

3.3.1.3.1 Adjustment - The foot pedals shall be readily adjustable in flight to at least 3" forward and 3" aft of neutral, increments not exceeding 1". Both pedals shall be adjusted simultaneously by means of a single control, and the control shall be located in accordance with MIL-STD-203. The angle of the pedals shall be adjustable on the ground only.

3.3.1.4 Blade Coning Restrainers - Suitable provisions shall be made to restrain coning of the blades when starting or stopping the rotor. It shall be possible to start or stop the rotor in wind velocities up to 60 knots, from any horizontal direction, without physical contact of the rotor blades with any part of the airframe. Means shall also be provided to prevent contact of the blades and airframe during flight maneuvers and hard landings.

3.3.1.5 Wheel Brake Controls - See paragraphs 3.2.2 through 3.2.2.4 above.

### 3.4 Additional Design and Installation Requirements for Lighter-Than-Air Aircraft.

#### 3.4.1 Primary Flight Controls

3.4.1.1 Longitudinal Control - Longitudinal control shall be by means of a wheel and column (yoke type). Forward movement of the wheel and column shall cause the aircraft to nose down and aft movement shall cause the aircraft to nose up. The range of movement of the longitudinal control shall be a maximum of 14". The extreme aft position shall not be more than 9" from the neutral position.

3.4.1.2 Directional Controls - Directional control shall be by means of the wheel on the column. Rotation of the wheel clockwise shall cause the airship to turn to the right and rotation of the wheel counter-clockwise shall cause the airship to turn to the left. The rotation of the wheel shall be a maximum of 110° clockwise and 110° counter-clockwise.

3.4.1.3 Control Surface Locks - See paragraphs 3.2.3 through 3.2.3.1.1 above.

#### 3.5 Tests and Design Data Requirements

3.5.1 General - The contract will specify the tests and design data of this Section 3.5, that will be required; will amplify or modify the tests and design data of this Section 3.5; and may specify other tests and design data under the appropriate section of this specification. The submittal procedures for the design data shall be as indicated in Specification SR-6.

3.5.1.1 Addition of Test and Design Data - If the tests and design data required by the contract are inadequate to prove that the flight control system and the flight control system installation incorporates the specified requirements, the contractor shall propose amendments to the contract to include tests and design data which will prove adequately that the flight control system and the flight control system installation incorporates the specified characteristics.

3.5.1.2 Deletion of Test and Design Data - If applicable test and design data are available, the contractor shall in lieu of repeating tests and submitting design data, propose amendments to the contract to require the submittal of these data, supplemented by sufficient information to substantiate, their applicability.

3.5.1.3 Test Witnesses - Before conducting a required test the Bureau of Aeronautics Representative shall be notified in sufficient time so that he or his representative may witness the test and certify results and observation contained in the test report. When the Bureau of Aeronautics Representative is notified, he shall be informed if the test is such that interpretation of the behavior of the test article is likely to require engineering knowledge and experience, in which case he will provide a qualified engineer who will witness the test and certify the results and observations during the test.

3.5.2 Experimental Aircraft - The following data shall be submitted:

- a. Simplified Schematic arrangement of the flight control system. (See 3.5.2.1)
- b. Flight control system design report. (See 3.5.2.2)
- c. Flight control system failure analysis report. (See 3.5.2.3)
- d. Flight control system test. (See 3.5.2.4)
- e. Flight control system test reports. (See 3.5.2.5)

3.5.2.1 Schematic Arrangement - The simplified schematic drawing shall show the functions of all elements (mechanical, hydraulic, electrical, pneumatic, aerodynamic, etc.) which constitute the flight control system of the aircraft. A description explaining the functioning of the complete system, functions of the individual elements, and other necessary explanations of the flight control system shall accompany the schematic arrangement.

3.5.2.2 Design Report - The design report shall be submitted prior to or concurrently with the drawings of paragraph 3.5.2.1 and shall contain the following information:

For Type I Control Systems - Curves or data shall be provided illustrating the following:

- a. Hinge moments developed at the reface for a unit load input at the pilot's control for the full range of travel of the control.
- b. Hinge moments developed at the surface for a unit load input at the pilot's control but with the system assumed to be deflected at design limit load for the full range of travel of the control. The effects of force augmenting devices such as spring bungees, centering springs, etc., shall be taken into consideration for the above data.
- c. Surface position versus cockpit control position for unit load input.
- d. Surface position versus cockpit control Position for design limit load.

For Type II Control Systems

- a. Same data as above for Type I Systems.
- b. The results and a description of the methods of an analysis of the stability and performance characteristics of the installed power boost unit. The stability results shall be in the form of Nyquist, Bode, Root Locus or similar diagrams. Estimates of the effects of any significant non-linearities shall be included. The performance results shall show the maximum rate of surface travel as a function of the surface hinge moment and a graph of control surface deflection versus time under design hinge moment.

The analysis shall be conducted for "on the ground stability" and for the most critical flight condition. However, the submittal of the analysis for the former should not be held up pending the availability of the latter.

The description of the methods of analysis shall be sufficiently detailed to permit review. Derivation of equations, sources of parameter values, and sample calculations shall be included.

For Type III Control Systems - Data similar to that required under Type II Control Systems shall be submitted.

3.5.2.3 Failure Analysis Report - The failure analysis report shall include assumed failure of each critical component in the most adverse position and/or condition. In addition, the report shall consider failures of secondary flight control systems and flight path angle and drag control systems and their effect on the primary control system. For Type II and Type III systems wherein the power source is hydraulic, electric, etc., the report shall include a failure analysis of the hydraulic, electric, etc., system and components. For each assumed failure the following shall be discussed:

- a. The consequences
- b. The compensating provisions
- c. Evaluation of the reliability of the critical component

3.5.2.4 Tests - For Type II and Type III Systems a working mock-up or simulator of the flight control system shall be constructed. Tests shall be conducted to check out the operation and stability of the system under simulated flight conditions.

3.5.2.5 System Test Reports - Prior to the conduction of the tests of 3.5.2.4, a report shall be submitted, for the approval of the Bureau of Aeronautics, outlining the test procedure. At the conclusion of the tests, a complete report of the tests shall be submitted. This report shall include a comparison of the test results with those obtained from the analysis of 3.3.2.2. Upon completion of the contractors flight test program, a report covering the performance of the flight control system and a comparison of the flight test results with the results of the theoretical and simulated analysis shall also be submitted.

3.5.3 Production Aircraft - The following data shall be submitted:

- a. Schematic arrangement of the flight control system. (See 3.5.3.1)
- b. Flight control system design report. (See 3.5.3.2)
- c. Plan and profile or isometric of the complete flight control system installation. (See 3.5.3.3)
- c. Flight control system installation drawings. (See 3.5.3.4)
- e. Flight control system component cross-section assembly drawings where necessary for clarification and for approval of individual units such as actuators, synthetic feel devices, spring cartridges, etc. (See 3.5.3.5)
- f. Flight control system failure analysis report. (See 3.5.3.6)
- g. Flight control system test. (See 3.5.3.7)

3.5.3.1 Schematic Arrangement -SUBMIT SAME AS 3.5.2.1 - Except bring up to date for production model airplane.

3.5.3.2 Desing Report - SUBMIT SAME AS 3.5.2.2 - Except bring up to date with latest available information.

3.5.3.3 Plan and Profile or Perspective of the Complete Flight Control System - The drawing of the complete flight control system shall be a plan and profile projection or a perspective type illustration. It shall show the complete control system installation including component and mechanical arrangement and shall be on the backgroud of the aircraft outline. Where necessary, sufficient aircraft structure shall be shown (may be in phantom) so that the relative vulnerability of the systems may be ascertained.

3.5.3.4 Installation Drawings - The installation drawings shall show the complete flight control system including mechanical, hydraulic or other power system components in addition to the motion geometry (trends) of principal linkages from the pilot's control to the operating surface. All attaching points, brackets, adjustment provisions, stops and rigging points, shall be indicated. These drawings shall be in sufficient detail to show sizes of cables, typical terminals, end fittings, levers, etc. The parts shall be labeled as to name and part number.

3.5.3.5 Component Cross-Section Assembly Drawings - Component cross-section assembly drawings shall contain sufficient information so that an evaluation of the unit can be made.

3.5.3.6 Failure Analysis Report - SUBMIT SAME AS 3.5.2.3 - Except bring up to date with latest revisions to the flight control system.

3.5.3.7 Tests - SUBMIT SAME AS 3.5.2.4 - Except bring up to date.

3.5.3.8 Test Report - SUBMIT SAME AS 3.5.2.5 - Except bring up to date with results of latest tests.

4. QUALITY ASSURANCE PROVISIONS - Not Applicable.
5. PREPARATION FOR DELIVERY - Not Applicable.
6. NOTES - Not Applicable.

PATENT NOTICE - When Government drawings, specifications, or other data are used for any purpose other than in connection with a definitely related Government procurement operation, the United States Government thereby incurs no responsibility nor any obligation whatsoever; and the fact that the Government may have formulated, furnished, or in any way supplied the said drawings, specifications or other data is not to be regarded by implication or otherwise as in any manner licensing the holder or any other person or corporation, or conveying any rights or permission to manufacture, use or sell any patented invention that may in any way be related thereto.





FOLD

---

POSTAGE AND FEES PAID



**OFFICIAL BUSINESS**  
PENALTY FOR PRIVATE USE \$300

Commander, Naval Air Systems Command  
Engineering Division  
Standardization Section, Code: AIR-52021  
Department of the Navy  
Washington, DC 20361

---

FOLD