



# **Space product assurance**

---

## **Crimping of high-reliability electrical connections**

**ECSS Secretariat  
ESA-ESTEC  
Requirements & Standards Division  
Noordwijk, The Netherlands**

## Foreword

This Standard is one of the series of ECSS Standards intended to be applied together for the management, engineering and product assurance in space projects and applications. ECSS is a cooperative effort of the European Space Agency, national space agencies and European industry associations for the purpose of developing and maintaining common standards. Requirements in this Standard are defined in terms of what shall be accomplished, rather than in terms of how to organize and perform the necessary work. This allows existing organizational structures and methods to be applied where they are effective, and for the structures and methods to evolve as necessary without rewriting the standards.

This Standard has been prepared by the ECSS Executive Secretariat, endorsed by the Document and Discipline Focal points, and approved by the ECSS Technical Authority.

## Disclaimer

ECSS does not provide any warranty whatsoever, whether expressed, implied, or statutory, including, but not limited to, any warranty of merchantability or fitness for a particular purpose or any warranty that the contents of the item are error-free. In no respect shall ECSS incur any liability for any damages, including, but not limited to, direct, indirect, special, or consequential damages arising out of, resulting from, or in any way connected to the use of this Standard, whether or not based upon warranty, business agreement, tort, or otherwise; whether or not injury was sustained by persons or property or otherwise; and whether or not loss was sustained from, or arose out of, the results of, the item, or any services that may be provided by ECSS.

Published by: ESA Requirements and Standards Division  
ESTEC, P.O. Box 299,  
2200 AG Noordwijk  
The Netherlands

Copyright: 2008 © by the European Space Agency for the members of ECSS

## Change log

ECSS-Q-70-26A 13 February 2001	First issue Transforming ESA PSS-01-726 into an ECSS Standard
ECSS-Q-70-26B	Never issued
ECSS-Q-ST-70-26C 31 July 2008	Second issue Changes to ECSS-Q-70-26A are: <ul style="list-style-type: none"><li>• Redrafting of ECSS-Q-70-26A in conformance with ECSS drafting rules and new template.</li><li>• The requirements of the original clauses 4, 5, 6, 7, and 8 were moved to the clause 5.</li><li>• New clause 5.6 "Document requirements".</li><li>• Informative material moved to clause 4 and informative Annex A "Crimp configurations and tools".</li></ul>

---

## Table of contents

---

<b>Change log</b> .....	<b>3</b>
<b>1 Scope</b> .....	<b>7</b>
<b>2 Normative references</b> .....	<b>9</b>
<b>3 Terms, definitions and abbreviated terms</b> .....	<b>10</b>
3.1 Terms defined in other standards.....	10
3.2 Terms specific to the present standard .....	10
3.3 Abbreviated terms .....	11
<b>4 Principles</b> .....	<b>12</b>
<b>5 Requirements</b> .....	<b>13</b>
5.1 Preparatory conditions .....	13
5.1.1 Facilities.....	13
5.1.2 Tools and equipment.....	14
5.2 Crimping operations for specific interconnections.....	15
5.2.1 General.....	15
5.2.2 Material selection.....	16
5.2.3 Process review and documentation.....	16
5.2.4 Connector barrel and single wire crimping .....	17
5.2.5 Connector barrel and multiple wire crimping .....	17
5.2.6 Ferrule shield crimping .....	18
5.2.7 Lug and splice wire crimping .....	19
5.3 Requirements for new crimp configurations .....	20
5.3.1 General.....	20
5.3.2 Test procedure .....	20
5.3.3 Sealing and marking.....	21
5.4 Test methods.....	22
5.4.1 General.....	22
5.4.2 Voltage drop .....	22
5.4.3 Tensile strength.....	24



5.4.4	Metallography .....	27
5.5	Quality assurance.....	27
5.5.1	General.....	27
5.5.2	Personnel training and certification .....	28
5.5.3	Workmanship.....	30
5.5.4	Visual inspection.....	31
5.5.5	Shift performance inspection and test .....	32
5.5.6	Calibration of crimping tools .....	32
5.5.7	Records .....	33
5.5.8	Nonconformance .....	34
5.6	Document requirements .....	34
<b>Annex A (informative) Crimp configurations and tools .....</b>		<b>35</b>
<b>Bibliography.....</b>		<b>41</b>
<b>Figures</b>		
Figure 1-1: Specific interconnections in this Standard .....		8
Figure 5-1: Example of a typical connector barrel and single wire crimping .....		17
Figure 5-2: Example of a typical connector barrel and multi-wire crimping.....		18
Figure 5-3: Example of a typical ferrule shield crimping.....		19
Figure 5-4: Examples of typical lug and splice wire crimping.....		20
Figure 5-5: Typical plots showing variation in crimp termination characteristics with increasing indentation depth.....		22
Figure 5-6: Measurement of voltage drop across a crimped termination .....		23
Figure 5-7: Quality control during crimping operation .....		29
Figure 5-8: Visible workmanship standards .....		30
Figure 5-9: Workmanship examples and crimp micro-sections.....		30
Figure A-1 : Confined irregular-octagon crimp (compactive).....		36
Figure A-2 : Dimpled confined octagon crimp (compactive).....		36
Figure A-3 : Regular-hexagon crimp (compactive).....		36
Figure A-4 : Semicircular one- or two-indent crimp (dispersive) .....		36
Figure A-5 : Four-indent crimp (dispersive).....		36
Figure A-6 : Typical test fixture for testing lug and splice crimps .....		40
<b>Tables</b>		
Table 5-1: Equipment for verification process .....		15
Table 5-2: Voltage drop test requirements .....		24
Table 5-3: Required ultimate axial strength for compactive and dispersive crimped joints ....		26



---

Table A-1 : Guideline for selector setting - Four-indent crimp (dispersive) Single wire (Crimping tool 22520/2-01) .....	38
Table A-2 : Guideline for selector setting - Four-indent crimp (dispersive) -Two wires (Crimping tool 22520/2-01) .....	39
Table A-3 : Guideline for die selection (ferrule coaxial shield crimping).....	39

---

# 1 Scope

---

This Standard specifies:

- Requirements for the following crimping wire terminations intended for high reliability electrical connections for use on customer spacecraft and associated equipment operating under high vacuum, thermal cycling and launch vibration:

- removable contacts, single wires
- removable contacts, multiple wires
- coaxial connectors, ferrules
- lugs and splices.

NOTE These are the most common used crimping wire termination and are represented in Figure 1-1.

- The general conditions to be met for the approval of terminations other than the above mentioned ones.

NOTE Additional forms of crimps, not covered in this standard, are listed (not exhaustively) in the informative Annex A.

- Product assurance provisions for both the specific and the generic terminations mentioned above.
- Training and certification requirements for operators and inspectors (clause 5.5.2), additional to those specified in ECSS-Q-ST-20.

This standard may be tailored for the specific characteristics and constraints of a space project, in conformance with ECSS-S-ST-00.

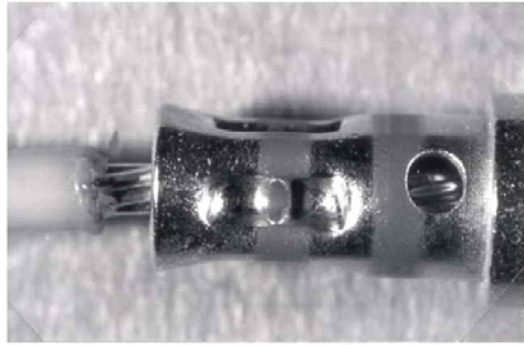

Removable co ntacts, single wires



Removable co ntacts, multiple wires

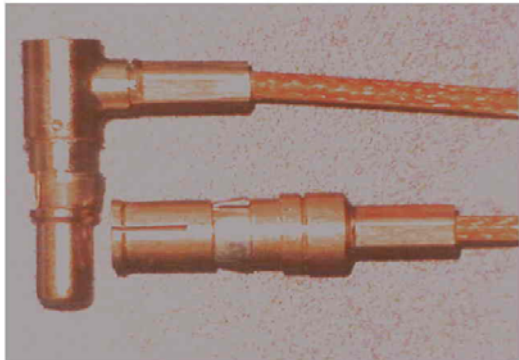

Coaxial connectors, ferrules

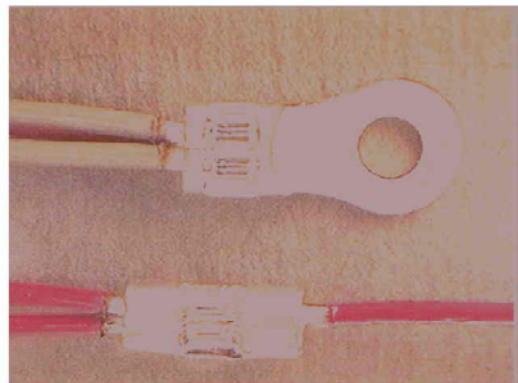

Lugs and splices

**Figure 1-1: Specific interconnections in this Standard**

## 2

# Normative references

The following normative documents contain provisions which, through reference in this text, constitute provisions of this ECSS Standard. For dated references, subsequent amendments to, or revisions of any of these publications do not apply. However, parties to agreements based on this ECSS Standard are encouraged to investigate the possibility of applying the most recent editions of the normative documents indicated below. For undated references the latest edition of the publication referred to applies.

ECSS-S-ST-00-01	ECSS system - Glossary of terms
ECSS-Q-ST-10-09	Space product assurance - Nonconformance control system
ECSS-Q-ST-20	Space product assurance - Quality assurance
ECSS-Q-ST-60	Space product assurance - Electrical, electronic and electromechanical (EEE) components
ECSS-Q-ST-70	Space product assurance - Materials, mechanical parts and processes
ECSS-Q-ST-70-08	Space product assurance - Manual soldering of high-reliability electrical connections
ECSS-Q-ST-70-38	Space product assurance - High-reliability soldering for surface-mount and mixed technology
ECSS-Q-ST-70-71	Space product assurance - Data for selection of space materials and processes
MIL-DTL-22520G	Crimping tools, terminal hard, wire termination, general specification for
NASA-STD-8739.4/CHG3 09/05/2006	Crimping, Interconnection cables, harnesses and wiring
SAE-AS-7928A 02/01/2008	Terminals, lugs, splices, conductor, crimp style, copper, general specification for
SAE-AS-81824 08/01/1998	Splices, electric, permanent, crimp style, copper, insulated, environment resistant

## 3

# Terms, definitions and abbreviated terms

---

## 3.1 Terms defined in other standards

For the purpose of this Standard, the terms and definitions from ECSS-S-ST-00-01 and ECSS-Q-ST-70-38 apply, in particular for the following terms:

**electrical connections**

**process identification document (PID)**

NOTE The DRD for the PID is given in ECSS-Q-ST-70-38.

## 3.2 Terms specific to the present standard

### 3.2.1 adjustable indenter tool

crimping tool which has an adjustable part (setting variable) that indents or compresses the conductor barrel or ferrule

### 3.2.2 crimping tool

mechanical tool used for permanently attaching a wire termination device to a conductor by pressure deformation or by reshaping the barrel around the conductor to establish good electrical and mechanical contact

### 3.2.3 ferrule

short metal tube used to make crimp connections to the outer conductor of shielded or coaxial cables

### 3.2.4 lug

metallic tube with drilled flange projection for fixing to threaded terminal

### 3.2.5 splice

device for joining two or more conductors to each other

### 3.2.6 terminal

metallic device that is used for making electrical connections

### 3.3 Abbreviated terms

For the purpose of this Standard, the abbreviated terms from ECSS-S-ST-00-01 and the following apply:

<b>Abbreviation</b>	<b>Meaning</b>
AWG	American wire gauge
QA	quality assurance
PID	process identification document
RFA	request for approval
RH	relative humidity

## 4 Principles

---

This Standard is structured such that the necessary level of quality is achieved and consistently maintained, and high reliability of the end product assured. The following principles are covered:

- Preparatory conditions determine the availability of facilities, tools and equipment, along with obligatory hazard and health precautions.
- Specific interconnections, as identified in the Scope above, are then covered in detail including
  - Material selection, and
  - Process identification and documentation.
- New crimp configurations beyond those identified above.
- Test methods and acceptance criteria for both specific and generic types of interconnections are specified.
- Quality assurance measures for both the operator and the inspector are prescribed
  - Training and certification of personnel,
  - Workmanship standards and acceptance criteria,
  - Inspection criteria and sequence,
  - Calibration of tools and equipment,
  - Records from material intake through delivery of the end product, including the handling of deviations by RFA or NCR.

It is important to perform the work taking into account health and safety regulations, and in particular the national standards on this subject.

# 5 Requirements

## 5.1 Preparatory conditions

### 5.1.1 Facilities

#### 5.1.1.1 Overview

The requirements in this clause can generally be met by using cleanrooms. It is not, however, mandatory to use a cleanroom.

#### 5.1.1.2 Facility cleanliness

- a. The supplier shall provide cleaning services for production facilities of high reliability crimping.
- b. The areas, in which crimping is carried out, shall be maintained in an orderly fashion.
- c. Loose material that can cause contamination of the crimped connection shall be removed.

NOTE For example: Dirt, dust, oils and clipped wires.

- d. Furniture shall be kept to a minimum in the work areas and be arranged to allow easy and thorough cleaning of the floor.
- e. Working surfaces shall be covered with an easily cleaned hard top or have a replaceable surface of clean, non-corrosive silicone-free paper.

#### 5.1.1.3 Environmental conditions

- a. The crimping area shall have a controlled environment, which limits entry of contamination.
- b. The area shall be continuously controlled as follows:
  1. room temperature:  $(22 \pm 3) ^\circ\text{C}$ ;
  2. relative humidity:  $(55 \pm 10) \%$ .
- c. The workstations shall not be exposed to draughts.
- d. Fresh air shall be supplied to the room through a filtering system with positive pressure difference with regard to adjacent rooms.
- e. The exhaust air shall be suitably restricted.

#### **5.1.1.4 Lighting requirements**

- a. The supplier shall ensure adequate illumination conditions of the crimp workstations.
- b. The light intensity shall be 1 080 lux on the work surface.
- c. 90 % of the work area shall be shadowless and without severe reflections.

### **5.1.2 Tools and equipment**

#### **5.1.2.1 Crimping tools**

- a. The supplier shall provide the tooling necessary for continued high quality crimping.
- b. Tools used shall employ an integral mechanism, which controls the crimping operation in conformance to MIL-DTL-22520G.

NOTE The mechanism ensures that, once the operation is started, the tool cannot be opened until the crimping cycle is complete.

- c. Tools shall be marked to show the size and type of termination for which it is calibrated.
- d. Tool calibration shall be verified once each shift in conformance with the clause 5.5.5 requirements.
- e. Proper operation of the integral ratcheting mechanism or the positive stops on pneumatic tools shall be verified as defined in clause 5.5.6.
- f. Before starting a crimping process on a new terminal size and wire type, tools used for crimping of the previous wire type shall be returned to the tool facility.
- g. If the tool settings seals are broken, the tool shall be returned immediately for recalibration.
- h. Tools used in the crimping operation shall be clean; excess lubricants shall be removed before crimping starts.

#### **5.1.2.2 Insulation strippers**

- a. The supplier shall provide the tooling necessary to avoid damage to the conductor.
- b. The selection of thermal or precision cutting devices, manual or automatic power-driven, shall provide protection of the conductor strands.
- c. Wire stretching by use of mechanical strippers shall be avoided.
- d. The conductor shall not be twisted, ringed, nicked, cut or scored by stripping operation.
- e. Both thermal and mechanical stripping tools shall be calibrated periodically on sample evaluation during a production run.

#### **5.1.2.3 Cutters and pliers**

- a. The supplier shall provide the tooling necessary for precision wire trimming and cutting.

- b. The cutter used for trimming conductor wire shall shear sharply and consistently produce a clean, flat, smooth-cut surface along the entire cutting edge.
- c. Twisting action during cutting operation shall be avoided.
- d. Smooth, long-nose pliers or tweezers shall be used for attaching or removing conductor wire.
- e. The cutting edges of pliers shall be regularly checked for damage and maintained in a sharp condition.

#### 5.1.2.4 Test and monitoring equipment

- a. The supplier shall provide the equipment specified in Table 5-1 necessary for verification activities specified in clauses 5.4.2 and 5.4.3.

**Table 5-1: Equipment for verification process**

Performance tests activity	Equipment characteristic
Voltage-drop (in conformance with clause 5.4.2 requirements)	0 A - 150 A current source and 0 mV - 10 mV voltmeter
Tensile strength (in conformance with clause 5.4.3 requirements)	Tensile testing machine 0 N - 4000 N, accurate to 1 % of full scale load, axial load applied at a rate of (25 – 50) mm/min $\pm$ 2 mm/min
Visual inspection	Microscope magnification $\times$ 7 to $\times$ 400
<b>Monitoring requirements of the process</b>	
Temperature	15 °C to 30 °C, accurate to $\pm$ 1 °C
Relative humidity (RH)	40 % to 70 %, accurate to $\pm$ 1 %

## 5.2 Crimping operations for specific interconnections

### 5.2.1 General

- a. The supplier shall visually examine wire, terminal and connector contacts for cleanliness, absence of oil films and freedom from tarnish or corrosion before assembly.
- b. The supplier shall perform cleaning of the work pieces in conformance with ECSS-Q-ST-70-08.
- c. Further cleaning or other treatment shall not be carried out.
- d. The supplier shall handle work pieces with clean lint free gloves or finger cots.
- e. Before a crimping activity, tools at the operator's station shall be verified to conform to those selected in accordance with the applicable PID.
- f. All conductor strands shall be inserted cleanly into the barrel without any buckling.
- g. Strands shall not be left outside or cut back to reduce the conductor diameter to fit an undersized barrel.

- h. The supplier shall use tools specified in MIL-DTL-22520.
  - NOTE Examples of crimping parameters are given in Table A-2 and Table A-3
- i. The supplier shall take provisions to avoid degradation of the silver plated wire caused by tarnish during storage.
- j. In cases when the same wire is joined later by soldering, the solder fluxes prescribed in ECSS-Q-ST-70-08 shall be used to avoid degradation.
  - NOTE For shift performance inspection requirements see clause 5.5.5.

### 5.2.2 Material selection

- a. The supplier shall use silver plated copper multi stranded wire and braided shield cable in crimp type connectors.
- b. Exceptional cases when nickel- or tin-plated wires are used shall be approved by the customer through a request for approval (RFA), in conformance with ECSS-Q-ST-70, clause 5.1.4.
- c. The supplier shall use high strength copper alloy wire for 24 AWG, 26 AWG and 28 AWG crimped joints.
  - NOTE Soft or annealed copper wire are not acceptable for crimped joints of 24 AWG, 26 AWG and 28 AWG size.
- d. The supplier shall use space-qualified components having gold plated terminals in conformance with ECSS-Q-ST-60.
- e. Specific terminals such as ferrules, splices and lugs shall be purchased to MIL or SAE-AS-7928 specifications.
- f. When gold plating is not available the finish shall be in conformance with ECSS-Q-ST-70-71.
- g. Cadmium, chromate-coated cadmium and non-fused tin-plating shall not be used.

### 5.2.3 Process review and documentation

- a. The supplier shall perform a review of all the materials, tools and techniques planned to be used to ensure conformance to requirements of this standard and as a means of identifying potential problems.
  - NOTE Type of wire includes number of strands, plating metal, type and thickness of insulation.
- b. Dies, setting of controls for the length of strip in automatic stripping machines and the selection of specific locators or positioners, shall be selected to meet process requirements.
  - NOTE The requirement is valid for power driven and manual crimping processes as well as for size and tolerance for crimping tools
- c. The results of the review shall be documented in a PID in conformance with DRD of ECSS-Q-ST-70-38.

### 5.2.4 Connector barrel and single wire crimping

- a. The supplier shall give preference to the selection of single wire interconnections.
- b. The supplier shall not use strands of wire doubled backed to increase the conductor diameter.
- c. The supplier shall use additional stranded wires to increase the cross-sectional area up to a selected barrel size;

NOTE The requirement is applied for cases where the insulation is prepared as normal and transparent “shrink-fit insulation” to cover the loose end of the wire to prevent any risk of a short circuit.

- d. For 28 AWG up to 16 AWG wire sizes, the maximum insulation clearance shall be equal to the outside diameter (over the insulation) of the wire being used.
- e. The gaps for larger size wires shall not exceed 2 mm.

NOTE No minimum gap is specified except that the conductor wire shall be visible to permit inspection.

- f. Where the terminal or contact is supplied with insulation support, the wire insulation shall enter the support to the extent that no bare wire is exposed.

NOTE An example of a typical connector barrel and single wire crimping is shown Figure 5-1.

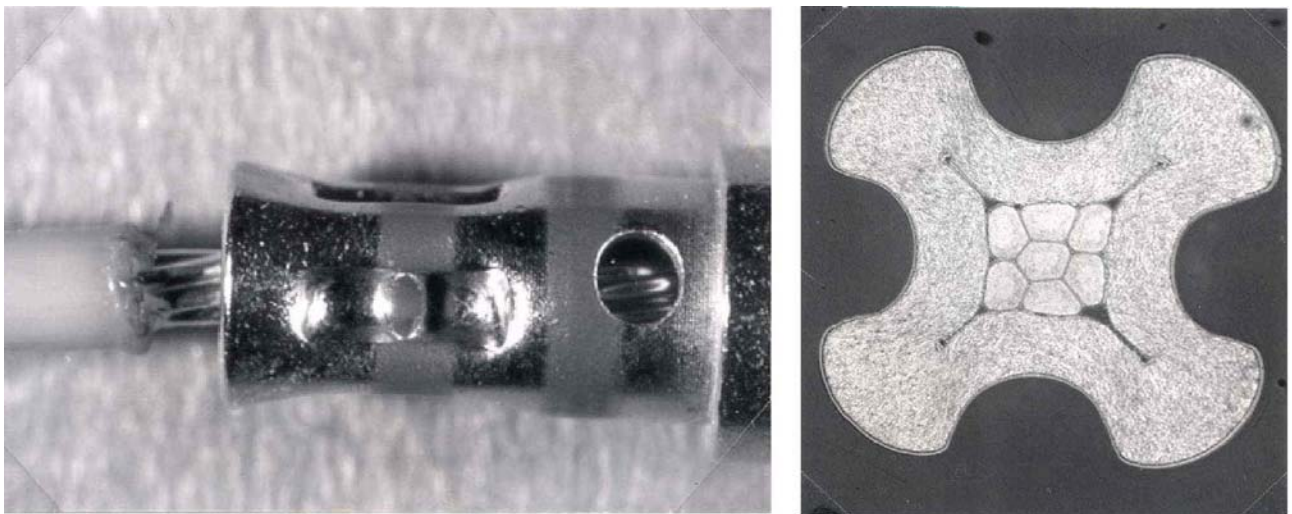

Figure 5-1: Example of a typical connector barrel and single wire crimping

### 5.2.5 Connector barrel and multiple wire crimping

- a. Requirements of this clause shall be applied when single wire crimping cannot be used.
- b. The maximum number of wires in one crimp barrel shall be two.
- c. The sum of the two nominal conductor sections shall be compatible with the crimp barrel used

NOTE  $2 \times 24$  AWG is approximately equal to  $1 \times 20$  AWG.

- d. Both conductors shall be of the same material and support the same plating finish.
- NOTE 1 For example: Both are silver and not a combination of silver and nickel
- NOTE 2 Before introduction into the barrel wires or conductors can be twisted to obtain a "single" conductor.
- e. Axial strength measurements shall be performed on the two associated wires and the axial strength shall be 75 % of the sum of the two wires axial strength requirements.
- f. For separate conductors introduced into the barrel the following shall apply:
1. the actual strength measurement is performed on one of the wires (the smaller, if two different sizes are used);
  2. the axial strength requirement is as quoted in Table 5-3 for the actual size of wire pulled, assuming a barrel size equal to that wire's gauge.
- NOTE Examples of crimping parameters are given in Table A-1 and an example of a typical connector barrel and multi-wire crimping is shown in Figure 5-2.

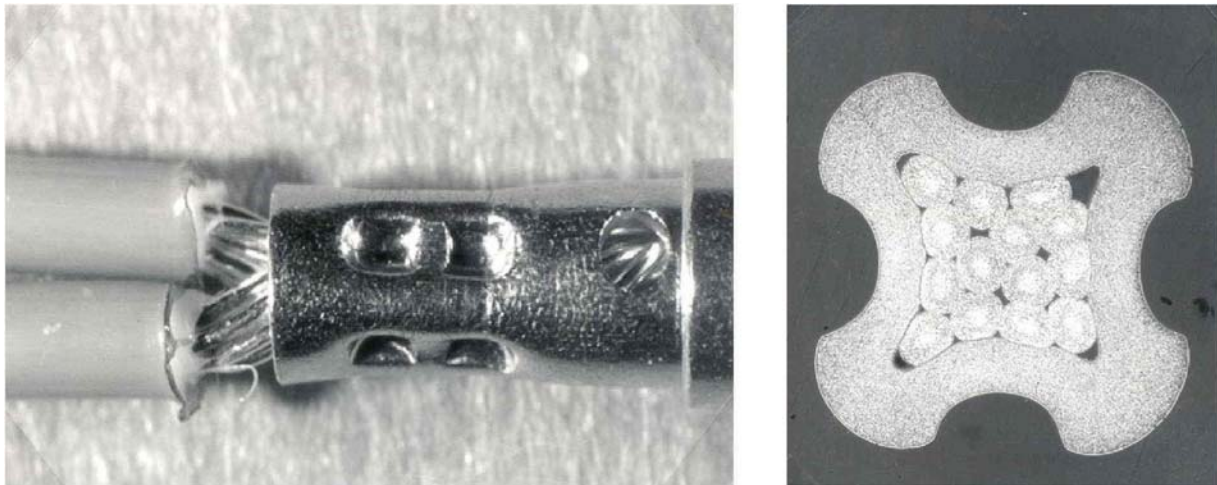

**Figure 5-2: Example of a typical connector barrel and multi-wire crimping**

### **5.2.6 Ferrule shield crimping**

- a. The shielded wires on coaxial cables shall be braided.
  - b. Axial strength measurements shall be performed only on the shield after removal of the core dielectric.
  - c. Following crimping, the assembly shall be protected by shrink tubing.
- NOTE Examples of crimping parameters are given in Table A-3 and an example of a typical ferrule shield crimping is shown in Figure 5-3.

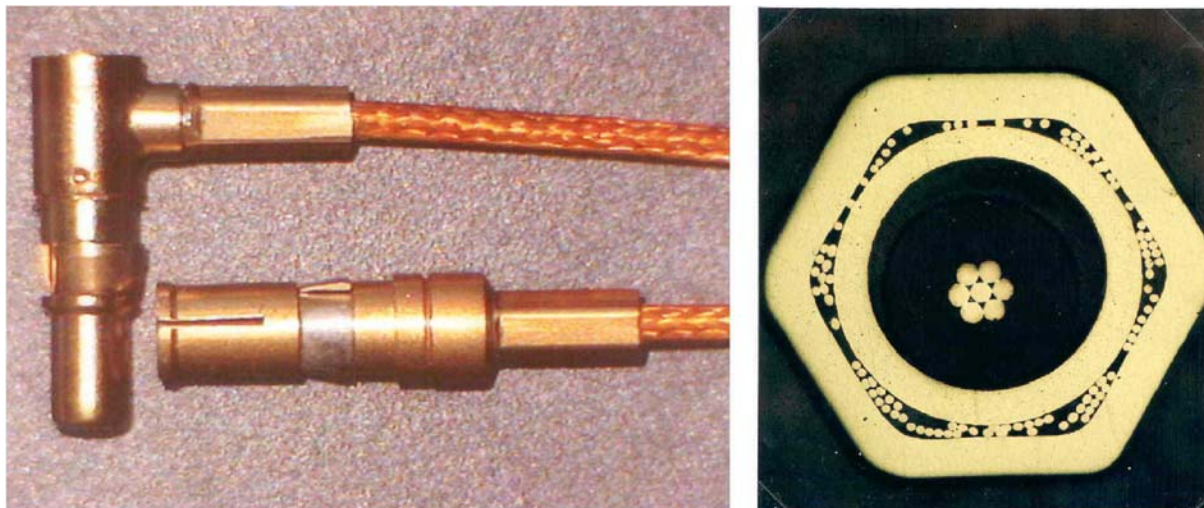

**Figure 5-3: Example of a typical ferrule shield crimping**

### **5.2.7 Lug and splice wire crimping**

- a. Tools specified by the manufacturer of the terminals shall be used.
- b. The maximum number of wires shall be ten.
- c. Seven wires maximum shall be on the same side.
- d. All conductors shall be of the same material and within a size range of 4 wire gauges on the same side.
- e. All conductors shall be positioned parallel in the terminal before crimping.
- f. Axial strength measurements shall be performed on
  1. all of the grouped wires for groups with equal wire sizes
  2. on the smallest wire for groups with different wire sizes.
- g. In the case where opposed wires are tested a specifically designed test fixture shall be used.

NOTE A typical test fixture is shown in Figure A-6.

- h. Following crimping, the assembly shall be protected by shrink tubing.

NOTE Examples of typical lug and splice wire crimping are shown in Figure 5-4.

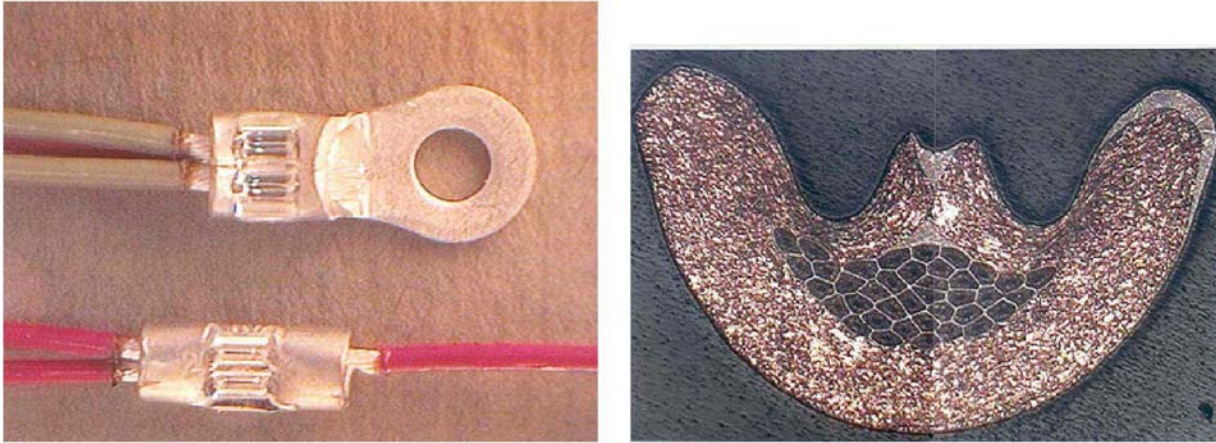

**Figure 5-4: Examples of typical lug and splice wire crimping**

## **5.3 Requirements for new crimp configurations**

### **5.3.1 General**

- a. Requirement of this clause shall be applied to crimp configurations that are not specified in clauses 5.2.4 to 5.2.7
- b. The supplier shall document the data of successful process qualification in the PID format to ensure continued high quality of production performance.
- c. An approved PID and additional relevant data from a previous project shall be presented to substantiate a RFA.

### **5.3.2 Test procedure**

- a. The supplier shall perform tensile strength and voltage drop tests on samples prepared at a number of tool settings, in conformance with the methods defined in clause 5.4 and in conformance with the following process:
  1. Ten samples prepared at the point specified by the crimping tool manufacturer as a starting point for calibrating tools and pulled (in conformance with Table A-1, Table A-2 and Table A-3).
  2. The tool indenter opening is then adjusted in convenient increments above and below this point, and ten samples pulled at each increment.
  3. Voltage drop tests are then performed on five samples for each tool setting.
  4. A plot is made with increments being close enough together to obtain a smooth curve.
  5. The minimum in voltage drop and maximum in tensile strength is then determined and evaluated as per Table 5-2 and Table 5-3.

6. The design value or operating point should lie approximately in the middle of the flat top portion of the tensile-strength plot, as per Figure 5-5
- b. The supplier shall validate satisfactory results achieved from the final tool setting at the operating point in conformance with the methods defined in clause 5.4 and according to the following process:
  1. Tensile strength tests are performed on five samples corresponding to the operating point.
  2. Voltage drop tests are performed on five samples corresponding to the operating point.
  3. Metallographic tests are performed on a minimum of three of these samples corresponding to the operating point.
  4. Not tested samples are retained for reference.

NOTE This approach is conducted from the variation of the main parameter involved to the relevant terminal crimping.

  - Connector barrel crimping: selector setting;
  - Ferrule crimping: die selection;
  - Lug and splice crimping: total cross-section of stranded wires.
- c. Test data shall be recorded for PID justification.

### 5.3.3 Sealing and marking

- a. The supplier shall seal and mark calibrated tools in conformance with clause 5.5.6.3 requirements.

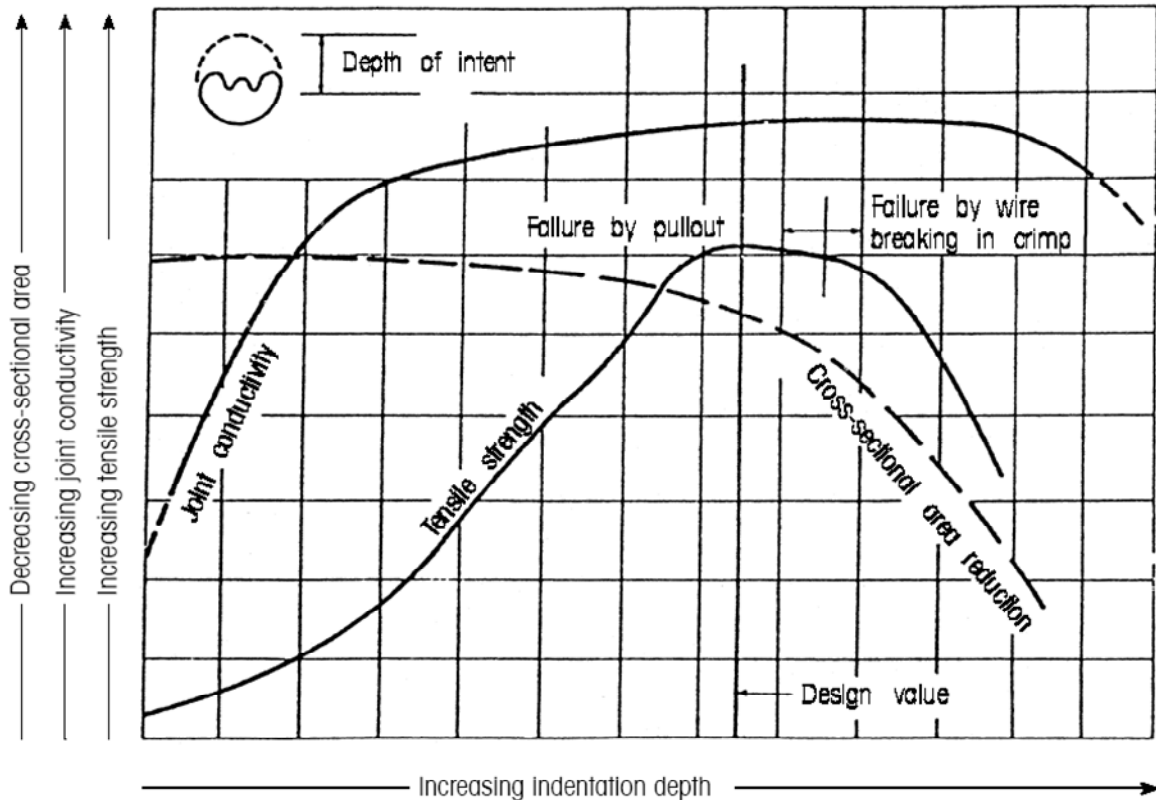

**Figure 5-5: Typical plots showing variation in crimp termination characteristics with increasing indentation depth**

## 5.4 Test methods

### 5.4.1 General

- a. The supplier shall submit samples to the tests detailed below.
 

NOTE The number of samples is dependent on the specific process requirement (in conformance with clauses 5.3.2 , 5.5.5 and 5.5.6.2 requirements).
- b. Test samples shall meet the requirements of clause 5.5.4.1.
- c. Records of all results shall be tabulated in conformance with 5.5.7.

### 5.4.2 Voltage drop

- a. The supplier shall measure the voltage drop from a point on the positioning shoulder of the contact to another point 14 mm distant on the attached wire (in conformance with the Table 5-2).
- b. In cases of two or more wires being crimped in the same contact, lug or splice, the voltage drop measurement shall be performed on each wire.
- c. The voltage drop of the contact crimp joint shall not exceed the value specified in Table 5-2 for each wire tested.

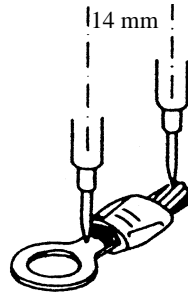

**Figure 5-6: Measurement of voltage drop across a crimped termination**

**Table 5-2: Voltage drop test requirements**

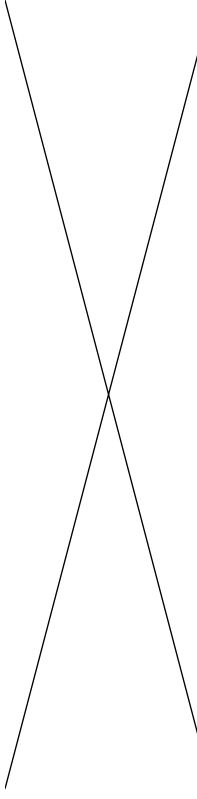
Wire barrel size	Wire size	Test current (A)	Maximum voltage-drop (mV)	
			Silver or tin-plated copper or copper alloy wire	Nickel-plated copper wire
0	0	150	3,0	4,5
4	4	80	4,0	4,0
6	6	60	4,5	-
8	8	45	3,0	3,5
10	10	33	4,0	-
12	12	23	3,0	
	14	17	3,5	
16	16	13	3,5	
	18	9,0	4,0	
	20	7,5	4,0	
20	20	7,5	4,0	
	22	5,0	4,0	
	24	3,0	4,0	
22	22	5,0	4,0	
	24	3,0	4,0	
	26	2,0	4,0	
24	24	3,0	4,0	
	26	2,0	4,0	
	28	1,5	5,0	
26	26	2,0	4,0	
	28	1,5	5,0	
28	28	1,5	5,0	

### 5.4.3 Tensile strength

#### 5.4.3.1 General

- a. The supplier shall use a tensile testing device with characteristics in conformance with Table 5-1.
- b. The connections shall be loaded until failure occurs.
- c. The value at failure shall be recorded, together with the information as to whether the failure was “pull-out”, “broke in crimp” or “break in wire”.
- d. The required ultimate axial strengths for compacted and dispersive crimped joints shall be as shown in Table 5-3 and in clauses 5.4.3.2 and 5.4.3.3.

- NOTE 1 The insulation may be stripped approximately 2 cm on test specimens to promote visual inspection of the mode of failure in the tensile test.
- NOTE 2 The required ultimate axial strength values for crimped copper alloy wire are calculated based on the requirement of a minimum wire strength of 343 N/mm<sup>2</sup>.
- NOTE 2 A typical test fixture for testing lug and splice crimps is shown in Figure A-6.

#### **5.4.3.2 Connector barrel wire crimping**

- a. The required axial strength shall be 75 % of the wire strength.
- b. Axial strength for copper and copper-alloy wires having either silver-, tin- or nickel-plated finishes shall be as specified in Table 5-3.

#### **5.4.3.3 Ferrule, lug and splice**

- a. The required axial strength shall be:
  1. 70 % of the shield strength,
  2. 70 % of one of the smallest gauge wires within the connection if pulled individually, or
  3. 70 % of the sum of all the wires axial strength requirements if all wires are pulled together.

**Table 5-3: Required ultimate axial strength for compactive and dispersive crimped joints**

Wire barrel	Wire size (AWG)	Axial strength (Newton)		
		Silver- or tin-plated copper wire	Nickel-plated copper wire	Silver plated Copper-alloy wire
0	0	3 120	2 800	-
	2	2 450	2 200	-
2	2	2 450	2 200	-
	4	1 780	1 600	-
4	4	1 780	1 600	-
	6	1 330	1 200	-
6	6	1 330	1 200	-
	8	980	890	-
8	8	1 250	1 150	-
10	10	710	-	-
	12	500	-	-
12	12	500	-	-
	14	320	-	-
16	16	230	-	-
	18	155	-	-
	20	90	-	-
20	20	90	-	185
	22	60	-	115
	24	-	-	60
22	22	60	-	115
	24	-	-	60
	26	-	-	45
24	24	-	-	60
	26	-	-	45
	28	-	-	30
26	26	-	-	45
	28	-	-	30
28	28	-	-	30

NOTE 1 Wire barrel size < 6 AWG tools are without adjustable setting.  
 NOTE 2 Wire barrel sizes ≥ 8 AWG tools are generally with adjustable settings which permit optimized crimped joints having higher axial strengths.

#### 5.4.4 Metallography

- a. The supplier shall employ a certified laboratory to perform the metallographic tests described below.
- b. The customer shall approve the certification status of the laboratory.
- c. The joint to be sectioned shall be mounted in a low exotherm resin capable of being moulded without the application of external pressure.
- d. The joint shall be oriented that the wire is perpendicular to the polishing surface.
- e. The specimen shall be ground with the aid of appropriate grades of silicon carbide papers, in order to expose the mid-section of the joint.
- f. This section shall then be polished with successively finer grades of diamond paste down to 1  $\mu\text{m}$ .
- g. To aid microscopic examination, the polished section shall be very lightly etched with an accepted chemical reagent specific to the composition of the materials being crimped.
- h. The section shall be examined in both as-polished and etched states using a metallographic microscope at a magnification up to  $\times 400$ .
- i. The following acceptance criteria shall be met:
  1. Each micro section is free from contamination;
  2. The crimp barrel is evenly deformed;
  3. Voids occupy less than 10 % of the cross sectioned area of the wire volume;
  4. The wires and barrel appear as a gas-tight joint and conform to the workmanship sample prepared during qualification;
  5. All wires are deformed from their circular cross section;
  6. There are no indentations or fracturing of the deformed receptacle barrel or its plated finish.

NOTE 1 For ferrule shield crimping the requirements of 5.4.4i.3. and 5. are not applicable.

NOTE 2 For wire barrel contact size 20 - 18 the requirement 5.4.4i.3. is not applicable due to localized voiding at the crimp corners.

## 5.5 Quality assurance

### 5.5.1 General

- a. The supplier shall install a Quality Assurance (QA) function in conformance with the requirements as defined in ECSS-Q-ST-20.
- b. The quality control process shall be as specified in Figure 5-7.

## 5.5.2 Personnel training and certification

### 5.5.2.1 Training program

- a. The supplier shall employ trained and competent personnel for all crimping operations.
- b. The supplier shall develop, maintain and implement a training programme, in conformance with ECSS-Q-ST-20.

NOTE The aim of the training programme is to provide for excellence of workmanship and personnel skills, careful and safe operations, and improvement of the quality of crimped joints.

### 5.5.2.2 Certification

- a. Trained personnel, performing crimping operations, shall be certified according to a customer approved process
- b. The certification of personnel shall be based upon objective evidence of crimp quality, resulting from test and inspection of the crimped joints.
- c. Operators or inspectors shall be re-certified in cases of repeatedly unacceptable quality levels and changes in crimping techniques, parameters or required skills.
- d. The supplier shall perform training and certification at a school authorized by the customer.

### 5.5.2.3 Documentation

- a. The supplier shall maintain records of the training and certification status of crimping operators and inspection personnel.

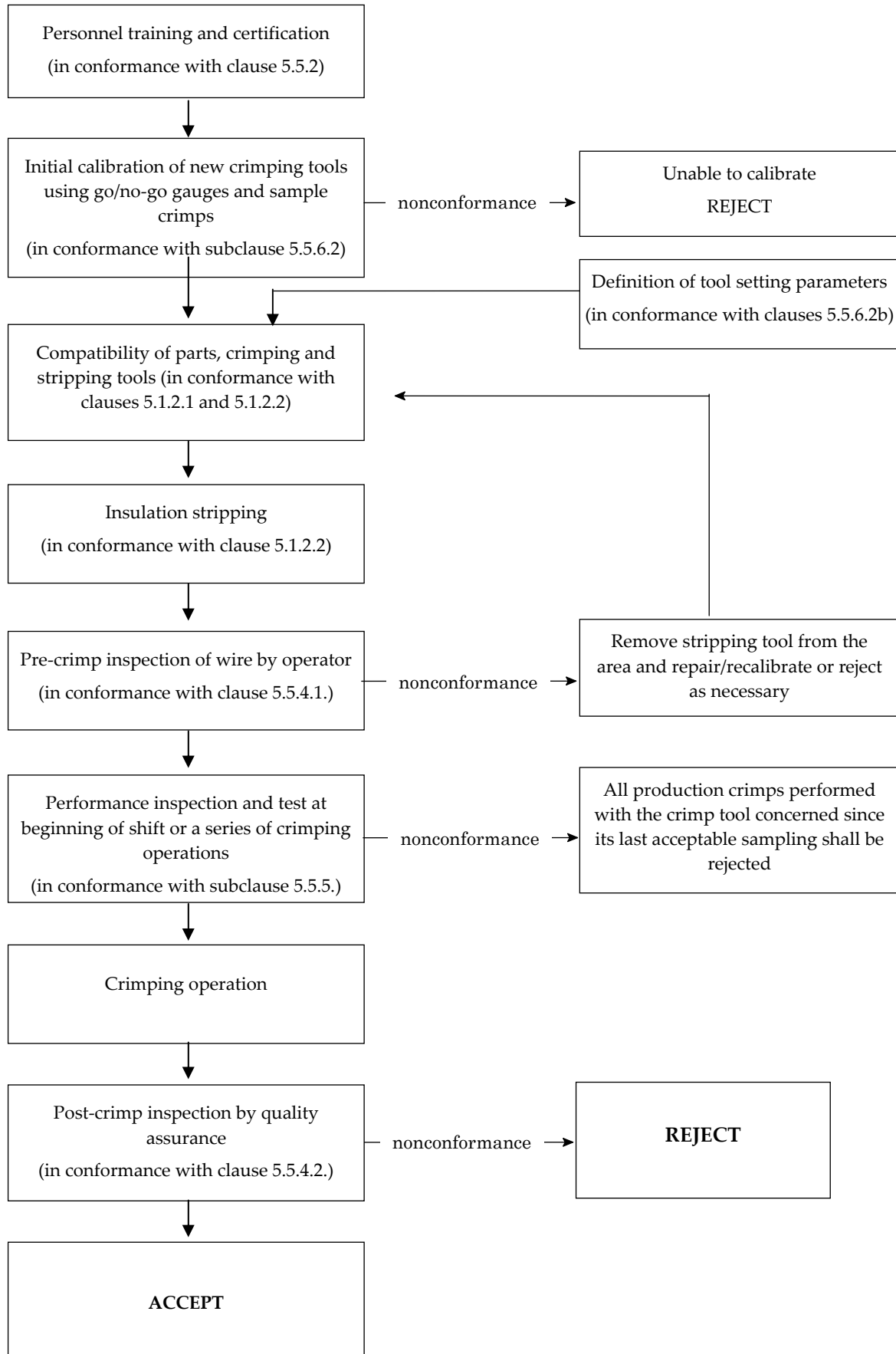

**Figure 5-7: Quality control during crimping operation**

### 5.5.3 Workmanship

- The supplier shall prepare standards consisting of satisfactory work samples (in conformance with the Figure 5-8 and Figure 5-9)
- The supplier shall have readily available visual aids, which clearly illustrate the quality characteristics of all crimped connections utilized.
- Defects such as those listed in clause 5.5.4.2 and shown in Figure 5-8 shall be included as examples.
- The operator shall discard production crimps which in his judgement are defective.
- Defective test samples shall not be discarded.

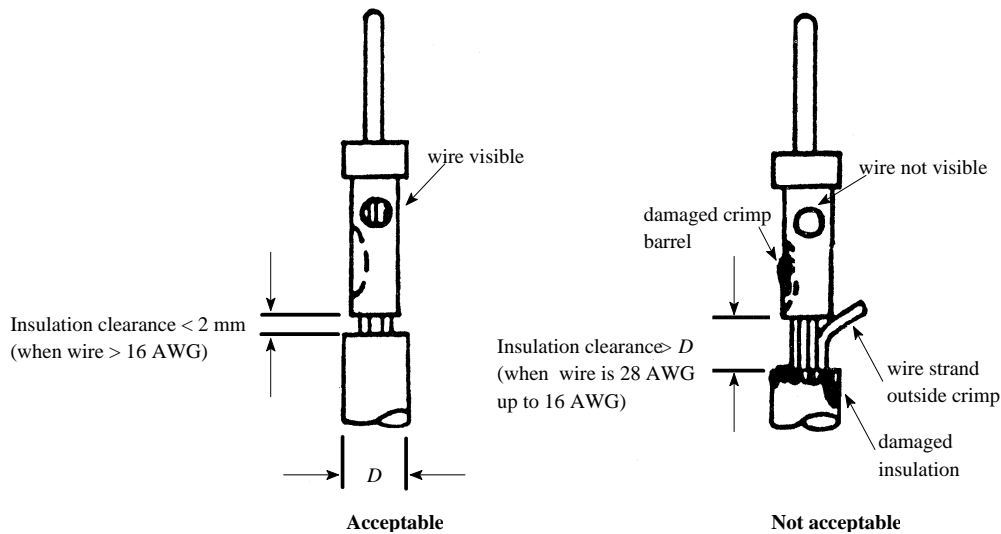

**Figure 5-8: Visible workmanship standards**

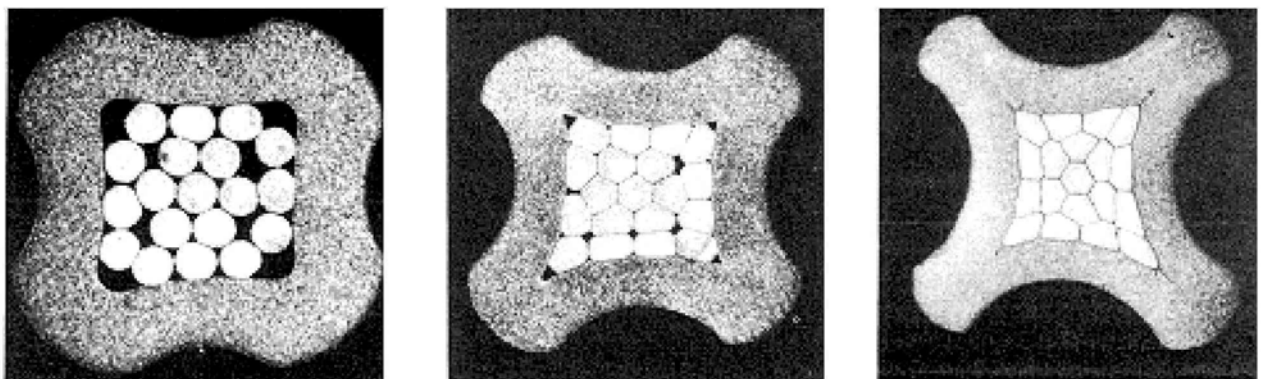

**Unacceptable \* undercrimp**  
 Voids greater than 10 %  
 Wire not deformed

**Acceptable**  
 All wire strands deformed  
 Voiding less than 10 %

**Preferred**

**Figure 5-9: Workmanship examples and crimp micro-sections**

## 5.5.4 Visual inspection

### 5.5.4.1 Pre-crimp inspection (performed by the operator)

- a. The operator shall examine the wire for nicks, rings, broken strands, untwisted lay or not-removed insulation in the area of the crimp before the stripped wire is inserted into the contact or terminal barrel.
- b. Damaged wires where the base material is exposed shall not be used.
- c. Contacts and terminal barrels that show evidence of the presence of tarnish, corrosion or physical damage, including bent contacts, shall not be used.
- d. Inspection shall verify that wire size and type, the contact and terminal are as specified in the drawing or control document.

### 5.5.4.2 Post-crimp inspection (performed by quality assurance)

- a. The QA inspector shall carry out inspection with the aid of a binocular microscope having an initial linear magnification of  $\times 7$ .

NOTE Further examination of surface characteristics can be performed at higher magnifications.

- b. The inspector shall not physically disturb parts and conductor leads to aid inspection.
- c. The following acceptance criteria shall be met;
  1. Insulation is not damaged by the crimping tool or the terminal;
  2. The conductor is visible in the inspection hole when an inspection hole is provided;
  3. The crimp barrel has no unintentional sharp edges, peeled metal, burrs, cracked platings or cuts after crimping;
  4. All functional parts, including all retention clips or locking devices, are operational after the crimp has been made;
  5. No tarnished or corroded contacts are present;
  6. No misplaced crimps, as determined by marks found on areas not designed to take crimping, are present;
  7. No undercrimps or overcrimps are present;

NOTE An undercrimp is detected by a loose conductor and an overcrimp by broken strands or deformed wire at end of terminal.

8. If undercrimps or overcrimps are detected this is cause to stop
  - o operations at that station,
  - o reject all production crimps made since the last verification or pull test,
  - o investigate tool, wire and terminals for the cause of failure.
9. No bent contacts are present.
- d. Failure to meet the acceptance criteria of 5.5.4.2c shall be cause for rejection.

## 5.5.5 Shift performance inspection and test

- a. Each operator shall prepare four samples at the beginning of a shift or before a series of crimping operations.
- b. At the end of the operation four further samples shall be crimped.
- c. Alternatively the supplier shall keep a logbook for each tool.
- d. The logbook shall show the quantity of parts crimped since each calibration and since each go/no-go operation.
- e. Four samples shall be crimped after each 100 crimping operations have been performed.
- f. A tool shall be changed whenever a wire size or contact size is changed.
- g. The operator shall prepare four samples at the start of the operation after such a change.

NOTE This can be omitted if samples have already been prepared by the tool during the shift.

- h. In each case, the operator shall submit three samples to the tensile strength test detailed in clause 5.4.3.
- i. The fourth sample shall be retained for reference and traceability purposes (in conformance with clause 5.5.6.2 requirements).
- j. The supplier shall perform an analysis of shift performance test results, in comparison with initial tool calibration results, to determine any drift in tool performance.

## 5.5.6 Calibration of crimping tools

### 5.5.6.1 General

- a. The QA organization of the supplier shall ensure that each crimping tool and piece of measuring equipment is calibrated as indicated in the subsequent sub clauses.
- b. The QA organization of the supplier shall record any suspected and actual equipment failure as a project nonconformance report

NOTE Based on past nonconformance reports previous results can be examined to ascertain whether or not re-inspection or retesting is required.

- c. The QA organization of the supplier shall notify the customer of the nonconformance details.
- d. The supplier's calibration procedure shall include the requirements specified in this clause for tool calibration.

### 5.5.6.2 Validation

- a. The QA organization of the supplier shall ensure that crimping tools, both manual and powered, are calibrated when initially set up for each specific wire size, connection size and type prior to first use.
- b. Calibration shall be verified in conformance with the following check-list:
  1. cleanliness control of the active part of the tool (e.g. indenters);

2. set up with the aid of the "go/no-go" gauge in conformance with specified conditions;
  3. tests in conformance with the clause 5.4 requirements on not less than four samples.
- c. After satisfactory calibration the tool status shall be documented in a "tool calibration sheet" to ensure tool traceability.
- d. This traceability shall be established by periodic analysis of the corresponding data from the shift performance inspection and tests (in conformance with clause 5.5.5 requirements),
- NOTE The frequency of analysis is defined in relation to production activity such as six months or 2 500 crimping operations.
- e. A significant drift in test results shall result in tool rejection.
- NOTE Such a tool is generally labelled "out-of-calibration tool" (in conformance with clause 5.5.6.4 requirements).

#### **5.5.6.3 Sealing and marking**

- a. The supplier shall provide sealing for calibrated crimping tools to ensure against unauthorized alteration of adjustment settings.
- b. A wire and lead seal method shall be used if the tool has provisions for it;
- c. Alternatively, the tool shall be sealed by a non-reusable decal seal, which, if the calibrated setting is altered, is visibly damaged.
- d. Seals shall be placed on all external adjustment points of the tool.

#### **5.5.6.4 Out-of-calibration tools**

- a. Tools that are out of calibration shall be returned to the tool facility for readjustment and calibration.
- b. Tools that are worn or damaged shall be identified as rejected and removed from the fabrication area.

#### **5.5.7 Records**

- a. The supplier shall maintain traceability throughout the process from incoming inspection to final test, including details of test equipment, tools and personnel employed in performing the task.
- b. Quality records and logbooks shall be retained for at least ten years
- c. Quality records and logbooks shall contain the following information:
  1. the as-built and test configuration list (waiver and deviation summary);
  2. non conformance reports and corrective actions;
  3. copy of the visual inspection and shift performance test results with reference to the relevant procedure, personnel and tools used;
  4. records of the training, testing and certification status of crimping operators (in conformance with clause 5.5.3 requirements) and ECSS-Q-ST-70-08.

### 5.5.8 Nonconformance

- a. The QA organization of the supplier shall disposition any nonconformance which is observed in respect of the process in conformance with the quality assurance requirements, in conformance with ECSS-Q-ST-20-09.
- b. Failure of a crimping tool to pass any requirement specified in clause 5.1.2.1 shall require rejection of all crimps made by that tool since it was last tested successfully for acceptance.

## 5.6 Document requirements

- a. The supplier shall produce documentation for:
  - 1. Process identification, PID and RFA,
  - 2. Inspection,
  - 3. Traceability,
  - 4. Testing, both procedures and records,
  - 5. Logbooks, and
  - 6. Calibration.
- b. The format of the documents shall be in accordance with the deliverables item list defined in the business agreement.

NOTE No specific DRD requirements emerge from this Standard.

## Annex A (informative)

# Crimp configurations and tools

---

### A.1 Overview of crimp configurations

Many crimp interconnection technologies are currently available for space applications. Confined or compactive crimps are made by a tool, which exerts an even pressure around the receptacle barrel circumference such that even deformation is applied on all sides; the only means of stress relief is by elongation of the barrel and wire (in conformance with Table A-1 to Table A-3 below).

Non-confined or dispersive crimps result from compression of the receptacle barrel with an indenter die having one or two indents or, alternatively, by two or four radially opposed indenter dies (in conformance with Figure A-4 and Figure A-5).

The achievement of a good crimped joint is controlled to a large extent by the tools and materials used, but workmanship - the manner in which they are employed - is also important. Items that constitute workmanship are those under the control of the operator. They include careful butting of the wire against the stop in the stripping operation to ensure correct insulation gap, loading of a connector pin in the positioner to the full distance, inserting the stripped wire into the connector pin barrel until it shows in the inspection hole and re-twisting the strands not more than the natural lay, if disturbed during the stripping operation.

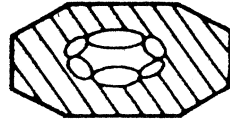

Figure A-1: Confined irregular-octagon crimp (compactive)

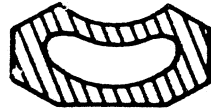

Figure A-2: Dimpled confined octagon crimp (compactive)

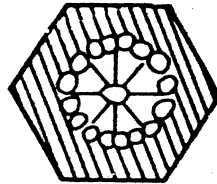

Figure A-3: Regular-hexagon crimp (compactive)



Figure A-4: Semicircular one- or two-indent crimp (dispersive)

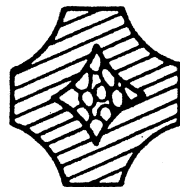

Figure A-5: Four-indent crimp (dispersive)

## A.2 Typical settings of crimping tools

For the type of crimping covered in this Standard typical tool selector settings are applicable. Those are, however, only indicative and require effective calibration or validation before use for production of high-reliability crimps, in conformance with clause 5.5.6

Tables for the different types of crimp configuration are shown below. They include reference to the tooling and selector settings by wire and barrel sizes.

For the specific case of lug and splice configurations where opposed wires are tested (in conformance with clause 5.4.3 requirements) a typical test fixture is shown in Figure A-6.

**Table A-1: Guideline for selector setting - Four-indent crimp (dispersive) Single wire (Crimping tool 22520/2-01)**

Connector	Wire gauge (AWG)	Wire barrel contact size	Selector setting
S U B * D	18	20 - 18	5
	20	20 - 18	5
	20	20 - 20	7
	22	20 - 20	6
	24	20 - 20	5
	26	20 - 26	6
	28	20 - 26	6
	22	22 - 22	4
	24	22 - 22	3
3 8 9 9 9	12	12 - 12	8 G
	16	16 - 16	7 G
	18	16 - 16	6 G
	20	16 - 16	5 G
	20	20 - 20	7
	22	20 - 20	6
	24	20 - 20	5
	22	22 - 22	5
	24	22 - 22	4
	26	22 - 22	3
D B A S	12	12 - 12	8 G
	20	12 - 16	6 G
	16	16 - 16	6 G
	18	16 - 16	5 G
	20	16 - 16	4 G
	20	20 - 20	6
	22	20 - 20	6
	24	20 - 20	5
	26	20 - 26	5
	28	20 - 26	5
H E 8 0 1	22	22 - 22	5
	24	22 - 22	4
	26	22 - 22	4

NOTE: G = Setting of crimping tool 22520/1-01

**Table A-2: Guideline for selector setting - Four-indent crimp (dispersive) -Two wires (Crimping tool 22520/2-01)**

Connector	Contact size	Combined wires (AWG)	Selector setting
S	20 - 18	20 + 22	6
U	20 - 18	22 + 22	5
B	20 - 20	24 + 24	6
*			
D	20 - 20	22 + 24	6

**Table A-3: Guideline for die selection (ferrule coaxial shield crimping)**

Coaxial connector ferrule	Coaxial cable	22520/5-01 tool die selection	22520/10-01 tool die selection
S	RG 178 BU	22520/5-03 B	22520/10-05 B
U	50 CIS	22520/5-03 A	22520/10-05 A
B	RG 180 BU	DANIELS Y 322 A	-
*			
D			
S	50 CIS	22520/5-03 A	22520/10-05 A
M			
A			

### A.3 Typical test fixture for pull tests

For the specific case of lug and splice configurations where opposed wires are tested, see clause 5.4.3, a typical test fixture is shown in Figure A-6.

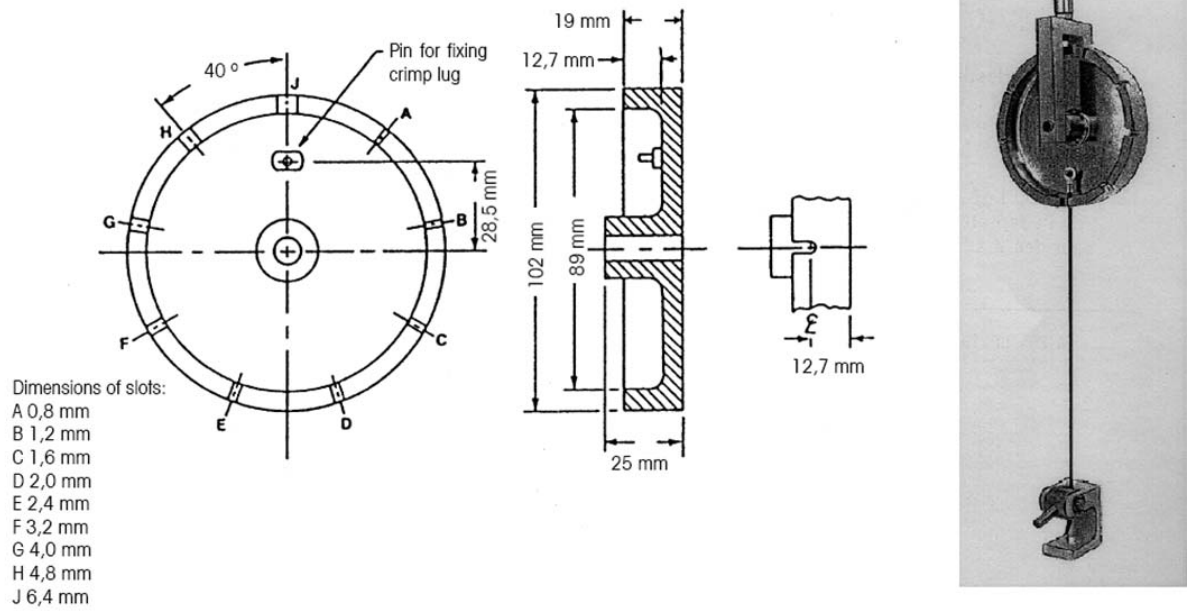

## Bibliography

---

ECSS-S-ST-00      ECSS system — Description and implementation  
and general requirements