



Space engineering

Insert design handbook

**ECSS Secretariat
ESA-ESTEC
Requirements & Standards Division
Noordwijk, The Netherlands**

Foreword

This Handbook is one document of the series of ECSS Documents intended to be used as supporting material for ECSS Standards in space projects and applications. ECSS is a cooperative effort of the European Space Agency, national space agencies and European industry associations for the purpose of developing and maintaining common standards.

This handbook has been prepared by the ECSS-E-HB-32-22 Working Group, reviewed by the ECSS Executive Secretariat and approved by the ECSS Technical Authority.

Disclaimer

ECSS does not provide any warranty whatsoever, whether expressed, implied, or statutory, including, but not limited to, any warranty of merchantability or fitness for a particular purpose or any warranty that the contents of the item are error-free. In no respect shall ECSS incur any liability for any damages, including, but not limited to, direct, indirect, special, or consequential damages arising out of, resulting from, or in any way connected to the use of this document, whether or not based upon warranty, business agreement, tort, or otherwise; whether or not injury was sustained by persons or property or otherwise; and whether or not loss was sustained from, or arose out of, the results of, the item, or any services that may be provided by ECSS.

Published by: ESA Requirements and Standards Division
ESTEC, P.O. Box 299,
2200 AG Noordwijk
The Netherlands

Copyright: 2011© by the European Space Agency for the members of ECSS



Change log

ECSS-E-HB-32-22A 20 March 2011	First issue.
-----------------------------------	--------------

Table of contents

Change log	3
1 Scope	27
2 References	28
3 Terms, definitions and abbreviated terms	29
4 Insert system	66
4.1 Insert systems and components.....	66
4.1.1 Inserts.....	66
4.1.2 Insert system components.....	68
4.1.3 Loading modes	69
5 Insert	70
5.1 General.....	70
5.2 Types.....	70
5.2.1 General.....	70
5.2.2 Group A	70
5.2.3 Group B	72
5.2.4 Group C	72
5.2.5 Potting methods.....	73
5.2.6 Injection	73
5.3 Sizes.....	74
5.3.1 General.....	74
5.3.2 Standards	74
5.3.3 Strength	75
5.3.4 Standardised diameters.....	76
5.3.5 Standardised heights.....	77
5.4 Materials.....	78
5.4.1 General.....	78
5.4.2 Aluminium alloys.....	79
5.4.3 Titanium alloys.....	79

5.4.4	Steels.....	80
5.4.5	Material selection.....	80
5.5	Surface protection	80
5.5.1	General.....	80
5.5.2	Aluminium alloy	81
5.6	References	82
5.6.1	General.....	82
5.6.2	ECSS standards.....	82
6	Sandwich panels	83
6.1	Sandwich properties.....	83
6.1.1	Insert load-bearing capability.....	83
6.1.2	Sandwich dimensions.....	84
6.2	Face sheet properties.....	84
6.2.1	Tensile and compressive loading	84
6.2.2	Shear loading	86
6.2.3	Other loads	88
6.3	Core properties.....	89
6.3.1	Types of cores	89
6.3.2	Hexagonal core	89
6.4	Core shear modulus	93
6.4.1	Data sources	93
6.5	Core shear strength.....	93
6.5.1	Data sources	94
6.6	Core tensile strength	94
6.6.1	Data sources	94
6.6.2	Aluminium core.....	94
6.6.3	Non-metallic cores.....	94
6.7	Core compressive strength	95
6.8	Core to face sheet bond	95
6.9	References	95
7	Embedding of inserts	96
7.1	Potting compounds.....	96
7.1.1	Commercial products.....	96
7.1.2	Modification of properties	98
7.2	Potting and equivalent dimensions.....	98
7.2.1	Insert load capability.....	98
7.2.2	Increasing insert tensile capability.....	100

7.3	Effective potting radius, or equivalent dimension	100
7.3.1	Minimum value	101
7.3.2	Average value.....	101
7.3.3	Relationship of minimum and average values.....	102
7.4	Real potting radius, or equivalent dimension.....	103
7.4.1	Minimum value	103
7.4.2	Average value.....	103
7.4.3	Relationship between minimum and average values	103
7.5	Potting height	104
7.5.1	Full potting.....	104
7.5.2	Partial potting.....	105
7.5.3	Minimum value	105
7.5.4	Average value.....	105
7.5.5	Relationship of minimum and average values.....	105
7.6	Potting mass.....	107
7.6.1	Effect of core and insert characteristics.....	107
7.6.2	Total mass of insert system.....	109
7.7	References	109
7.7.1	General.....	109
7.7.2	ECSS standards.....	109
8	Mechanics of sandwich structures	110
8.1	Structural sandwich concept	110
8.1.1	Properties of constituent materials	111
8.1.2	Fundamentals of classical ‘antiplane’ sandwich theory	112
8.2	Structural failure modes	116
8.2.1	Global failure modes.....	117
8.2.2	Local failure modes	117
8.3	Load introduction aspects and discontinuities.....	117
8.3.1	General.....	117
8.3.2	Local bending response	118
8.3.3	Antiplane-type theory.....	119
8.3.4	Finite element analysis.....	119
8.3.5	Elastic foundation model	119
8.3.6	Transverse flexibility	119
8.3.7	Higher-order sandwich beam theory	119
8.4	Sandwich plates with potted inserts	120
8.4.1	Classification of potted insert types.....	120

8.4.2	Load transfer	121
8.4.3	External load cases	121
8.4.4	Example.....	123
8.4.5	Purpose of the potting compound.....	128
8.4.6	Design guidelines	128
8.5	Remarks	129
8.5.1	General.....	129
8.5.2	Antiplane theories.....	129
8.5.3	Higher-order theories.....	130
8.5.4	ESAComp®	130
8.6	References	131
8.6.1	General.....	131
8.6.2	ECSS standards.....	133
9	Design aspects	134
9.1	Design parameters	134
9.1.1	Metal face sheets	136
9.1.2	Composite face sheets.....	136
9.2	Main load directions	137
9.2.1	Out-of-plane load.....	137
9.2.2	In-plane load.....	138
9.3	References	138
9.3.1	General.....	138
9.3.2	ECSS standards.....	138
10	Design considerations	139
10.1	Insert arrangement.....	139
10.1.1	Load capability.....	140
10.2	Load conditions	141
10.2.1	General.....	141
10.2.2	Design guide.....	143
10.3	Mounting modes.....	147
10.3.1	General.....	147
10.3.2	Flush-mounted insert.....	147
10.3.3	Recessed insert.....	147
10.3.4	Protruding insert	148
10.3.5	Bonded flange	149
10.4	Junction of components	149
10.4.1	General.....	149

10.4.2	Minimum value	150
10.5	Adequate insert design.....	151
10.5.1	Insert arrangement	151
10.5.2	Typical spacecraft design	151
10.5.3	Examples.....	152
10.6	Selection of inserts	152
10.6.1	General.....	152
10.6.2	Sufficient static strength	153
10.6.3	Safety factor	154
10.7	Minimum and average insert capability	154
10.7.1	Minimum	154
10.7.2	Average	155
10.8	Pre-design	155
10.8.1	Load path for in-plane forces.....	156
10.8.2	Load path for transverse forces.....	158
10.8.3	Transverse and in-plane load interaction	159
10.8.4	Proximity and edge effects	159
10.9	Failure modes.....	159
10.9.1	General.....	159
10.9.2	Failures under out-of-plane loads.....	160
10.9.3	Failures under in-plane loads	165
10.10	References	167
10.10.1	General.....	167
11	Design flow chart.....	168
11.1	Introduction.....	168
11.2	Flow chart: Predefined sandwich and loads.....	168
11.3	Flow chart: Variable main parameters.....	170
11.4	References	171
11.4.1	General.....	171
12	Tensile strength.....	172
12.1	Normal tensile load.....	172
12.1.1	General.....	172
12.1.2	Failure modes.....	172
12.1.3	Shear rupture: core surrounding the potting.....	173
12.1.4	Tensile rupture: core underneath the potting.....	174
12.1.5	Tensile rupture: potting underneath the insert.....	175
12.2	Basic parameters	175



12.2.1	Out-of-plane loads: Insert strength	178
12.3	Minimum and average design values	180
12.3.1	Overview.....	180
12.3.2	Minimum insert design values	180
12.3.3	Average insert values	181
12.4	Safety factors	182
12.4.1	Load capability.....	182
12.4.2	Failure modes.....	183
12.5	Permissible tensile loads	183
12.5.1	General.....	183
12.5.2	Insert capability graphs.....	183
12.5.3	Design values	183
12.6	Influence of insert height	184
12.6.1	Insert capability graphs.....	184
12.6.2	Different insert heights.....	184
12.7	Composite face sheet.....	186
12.7.1	Effect of anisotropy.....	186
12.7.2	Loading by moments	186
12.8	References	186
12.8.1	General.....	186
13	Compressive strength.....	187
13.1	Normal compressive load.....	187
13.1.1	General.....	187
13.1.2	Partially-potted inserts	187
13.1.3	Potting strength	187
13.1.4	Increased face sheet thickness	187
13.1.5	Insert capabilities.....	188
13.2	Permissible compressive loads	188
13.2.1	Graphs of permissible static insert loads.....	188
13.3	Composite face sheet.....	188
14	Shear strength	190
14.1	Shear (in-plane) load.....	190
14.1.1	Effect of in-plane load.....	190
14.1.2	Effect of face sheet material	191
14.1.3	Effect of partial clamping	191
14.2	Permissible shear load.....	191
14.3	Composite face sheet.....	192



14.3.1	Strength	192
14.3.2	Face sheets	195
14.3.3	CFRP face sheets	195
14.3.4	Effect of panel layout.....	200
14.3.5	Sensitivity of insert strength	201
14.3.6	Effect of thin CFRP face sheet	202
14.4	References	203
14.4.1	General.....	203
15	Bending strength.....	204
15.1	Bending load	204
15.2	Permissible bending load	205
15.3	Composite face sheet.....	206
15.4	References	207
15.4.1	General.....	207
16	Torsional strength	208
16.1	Torsional load.....	208
16.2	Permissible torsion load	208
16.2.1	General.....	208
16.2.2	Metallic core	208
16.2.3	Non-metallic core.....	209
16.3	Composite face sheets.....	209
16.4	References	210
16.4.1	General.....	210
17	Combined loads.....	211
17.1	Inclined load	211
17.2	General load combinations.....	212
18	Edge influence	214
18.1	Edge distance: Out-of-plane loading	214
18.2	Edge distance: Shear loaded	215
18.2.1	General.....	215
18.2.2	Metallic face sheets.....	216
18.2.3	Non-metallic face sheets	216
18.3	Composite face sheets.....	217
18.3.1	Out-of-plane loading.....	217
18.3.2	In-plane loaded inserts	217
18.4	References	217



18.4.1	General.....	217
19	Insert groups.....	218
19.1	Two inserts: Loaded in same direction.....	218
19.1.1	General.....	218
19.1.2	Close inserts.....	218
19.1.3	Distant inserts.....	219
19.1.4	Effect of load.....	219
19.2	Two inserts: Loaded in opposite directions.....	220
19.2.1	General.....	220
19.2.2	Close inserts.....	221
19.2.3	Distant inserts.....	221
19.3	Series of inserts: Loaded in same direction.....	221
19.3.1	Overview.....	221
19.3.2	First and last inserts.....	221
19.3.3	Intermediate inserts.....	222
19.3.4	Example.....	222
19.4	Series of inserts: Loaded in opposite directions.....	223
19.4.1	Overview.....	223
19.4.2	First and last insert.....	224
19.4.3	Intermediate inserts.....	224
19.5	Insert groups: Loaded in same direction.....	224
19.5.1	General.....	224
19.5.2	Equal and equidistant inserts.....	224
19.6	Composite face sheets.....	226
19.6.1	Out-of-plane loading.....	226
19.6.2	In-plane loaded inserts.....	226
19.7	References.....	226
19.7.1	General.....	226
20	Stiffness.....	228
20.1	Introduction.....	228
20.1.1	Overview.....	228
20.1.2	Rotational stiffness.....	228
20.1.3	In-plane stiffness.....	228
20.1.4	Out-of-plane stiffness.....	228
20.2	Analysis and test.....	229
20.2.1	General.....	229
20.2.2	Analysis.....	229



20.2.3	Testing.....	229
20.2.4	Comparison of analysis and test values.....	229
20.2.5	Composite face sheets.....	230
20.3	References.....	230
20.3.1	General.....	230
21	Fatigue.....	231
21.1	Insert fatigue life.....	231
21.1.1	General.....	231
21.1.2	Potting.....	231
21.1.3	Honeycomb core.....	231
21.2	Core local stress: Normal loads to plane.....	232
21.2.1	General.....	232
21.2.2	Core circular stress.....	232
21.2.3	Example.....	233
21.3	Load-stress sequence: Constant amplitude.....	236
21.3.1	General.....	236
21.3.2	Mean stress ratio.....	236
21.3.3	Maximum peak load.....	237
21.4	Load-stress sequence: Spectra of constant amplitude.....	237
21.4.1	General.....	237
21.4.2	Example.....	237
21.5	Fatigue life: Constant load amplitude.....	237
21.5.1	Fatigue damage.....	237
21.5.2	Fatigue life.....	238
21.5.3	Re-evaluation of core strength variation.....	239
21.5.4	Insert fatigue life: Metallic cores.....	240
21.5.5	Insert fatigue life: Non-metallic cores.....	251
21.6	Fatigue damage accumulation.....	252
21.7	Non-metallic core.....	252
21.8	Composite face sheets.....	254
21.9	References.....	254
21.9.1	General.....	254
21.9.2	ECSS standards.....	255
22	Environmental effects.....	256
22.1	Insert under thermal conditions.....	256
22.1.1	General.....	256
22.1.2	Mechanical loading in a thermal environment.....	256



22.1.3	Mechanical loading after exposure to a thermal environment	256
22.1.4	Mechanical loading after thermal cycling.....	256
22.2	Thermal: Reduction of permissible load	258
22.2.1	Effect on permissible loads.....	258
22.2.2	Coefficient of thermal degradation.....	258
22.3	Other conditions	259
22.4	Composite face sheets.....	260
22.4.1	In-plane load under thermal conditions	260
22.5	References	260
22.5.1	General.....	260
22.5.2	ECSS standards.....	260
23	Manufacturing procedures	262
23.1	Sequence	262
23.1.1	General.....	262
23.1.2	Sandwich panels	262
23.2	Fit inserts.....	263
23.2.1	General.....	263
23.2.2	Positioning.....	263
23.2.3	Perforated core.....	264
23.2.4	Non-perforated core	264
23.3	Inject potting compound	265
23.3.1	General.....	265
23.3.2	Process.....	266
23.3.3	Flow characteristics.....	266
23.4	Cure cycle	267
23.4.1	General.....	267
23.4.2	Resin system: Shur-Lok SLE 3010.....	267
23.4.3	Potting foam: Lekutherm X227+T3.....	267
23.4.4	Other resin systems.....	267
23.5	Corrective actions.....	268
23.5.1	General.....	268
23.5.2	Final machining	268
23.6	Reference sample	268
23.6.1	General.....	268
23.6.2	Materials	269
23.6.3	Manufacture.....	269
23.6.4	Number of samples	269

23.6.5	Pull-out strength test.....	269
23.7	Proof load	270
23.8	Inspection	270
23.9	Repair.....	271
23.9.1	General.....	271
23.9.2	Undamaged core or face-sheet	271
23.9.3	Damaged core and face sheet	272
23.9.4	Replace or reposition inserts	272
23.10	Defects	273
23.10.1	Poor storage of potting compound	273
23.10.2	Poor potting compound distribution	274
23.10.3	Poor positioning of insert	275
23.10.4	Oversized bore hole size	276
23.11	References	276
23.11.1	General.....	276
23.11.2	ECSS standards.....	277
24	Sandwich panel machining.....	278
24.1	Drilling bore holes.....	278
24.1.1	Bore hole geometry	278
24.2	Processing.....	279
24.2.1	Combined tool	279
24.2.2	Single tools.....	280
24.2.3	Drill face sheet then cut honeycomb core	280
24.2.4	Drill face sheet and honeycomb core	281
24.2.5	Coordinate drilling machines	281
24.3	Composite face sheets.....	282
24.4	Process control.....	282
24.4.1	Potential problems.....	282
24.5	References	283
24.5.1	General.....	283
24.5.2	ECSS standards.....	283
25	Potting	284
25.1	General.....	284
25.1.1	Environmental conditions	284
25.1.2	Face sheet protection.....	284
25.1.3	Degreasing of inserts.....	284
25.2	Manufacturing process	284



25.3	Potting compounds.....	285
25.3.1	Flow characteristics	285
25.3.2	Resin system: Shur-Lok SLE 3010.....	286
25.3.3	Potting foam: Lekutherm X227+T3.....	286
25.3.4	Other potting materials	286
25.4	References	287
25.4.1	General.....	287
25.4.2	ECSS standards.....	288
26	Incoming inspection.....	289
26.1	Tests.....	289
26.1.1	Material specifications	289
26.1.2	Additional tests	289
26.2	Honeycomb core	289
26.2.1	Core properties.....	289
26.2.2	Insert strength.....	290
26.3	Potting resin	290
26.3.1	Strength	290
26.3.2	Hardness	291
26.4	Composite face sheets.....	291
26.4.1	Material characteristics.....	291
26.4.2	Composite laminate properties.....	291
26.4.3	Consumables.....	292
26.5	References	292
26.5.1	General.....	292
26.5.2	ECSS standards.....	292
27	Manufacture control	293
27.1	Testing.....	293
27.1.1	General.....	293
27.1.2	Mechanical	293
27.1.3	Non-destructive	293
27.1.4	Development tests.....	293
27.2	Reference samples	294
27.3	Mechanical testing.....	294
27.3.1	Tensile pull-out test	295
27.3.2	Shear test	296
27.3.3	Torsion test.....	298
27.4	Non-destructive testing.....	299



27.4.1	Radiography	299
27.5	Composite face sheets	299
27.6	References	300
27.6.1	General	300
27.6.2	ECSS standards	300
28	Quality control	301
28.1	General	301
28.1.1	Materials and processes	301
28.1.2	Documentation and traceability	302
28.1.3	Personnel	302
28.1.4	Health and safety	302
28.2	Control of bore hole	302
28.2.1	Inspection criteria	302
28.3	Control of potting	303
28.4	Core incoming inspection	306
28.4.1	Minimum core strength values	306
28.4.2	Inspection sequence	306
28.4.3	Perforated cores	307
28.5	Core normalised density	307
28.5.1	Procedure	307
28.6	References	308
28.6.1	General	308
28.6.2	ECSS standards	309
29	Testing	310
29.1	General	310
29.2	Insert static strength tests	310
29.2.1	Out-of-plane tests	310
29.2.2	In-plane tests	311
29.2.3	Bending tests	314
29.2.4	Torsion tests	314
29.3	Geometric effects: Insert static strength tests	315
29.3.1	Edge distance	315
29.3.2	Insert proximity	315
29.4	Dynamic tests	317
29.4.1	Sinusoidal loads	317
29.4.2	Static residual strength test	317
29.5	References	318



29.5.1	General.....	318
Annex A Inserts		319
A.1	Introduction.....	319
A.2	Commercial products	319
A.3	Non-standard.....	321
A.4	References	327
Annex B Permissible loads.....		328
B.1	Introduction.....	328
B.2	Index to permissible-load graphs	329
B.3	References	330
Annex C Analytical determination		331
C.1	Introduction.....	331
C.2	Fully potted insert.....	332
C.3	Partial potting	335
C.4	Potting failure	338
C.5	Compressive loading.....	341
C.6	Reliability.....	342
C.7	References	343
Annex D Estimation of static load-carrying capability.....		344
D.1	Introduction.....	344
D.2	Out of plane loading	345
D.3	Fully potted inserts	348
D.4	Partially potted inserts	349
D.5	Potting failure	352
D.6	Compressive load: Additional criteria	355
D.7	Reliability considerations.....	356
D.8	Design graphs	358
D.9	Other external loads.....	359
D.10	References	360
Annex E IATP		362
E.1	Introduction.....	362
E.2	Materials.....	362
E.3	Testing.....	364
E.4	Test data	366
E.5	References	373

Annex F Case studies	374
F.1 Introduction.....	374
F.2 ARIANE 1 Equipment Bay.....	376
F.3 ARIANE 4 Equipment Bay.....	377
F.4 ASAP 4.....	383
F.5 ASAP 5.....	388
F.6 ROSETTA Lander	392
F.7 SPOT 5.....	398
F.8 UMS	401
F.9 SILEX	403
F.10 HRG	410
F.11 NILESAT	413
F.12 EXAMPLE: Insert verification	417
F.13 References	421
Annex G Formulae.....	422
G.1 Introduction.....	422
G.2 Nomenclature	422
G.3 List of mathematical formulae	425
Annex H Insert test fixtures	437
H.1 Introduction.....	437
H.2 Test fixture: Tension-Compression load.....	437
H.3 Test fixture: In-plane shear load.....	446
H.4 Test fixture: Bending	455
H.5 Test fixture: Torsion.....	469
H.6 References	488
Figures	
Figure 4-1: Insert system: Components	67
Figure 4-2: Insert system: Summary of loading modes.....	69
Figure 5-1: Typical insert.....	72
Figure 5-2: Standardised insert diameter	76
Figure 5-3: Standardised insert height	77
Figure 5-4 Preferred set of insert heights.....	78
Figure 6-1: Sandwich and core: designation	84
Figure 6-2: Face sheet properties: Isotropic, anisotropic and quasi-isotropic characteristics.....	85
Figure 6-3: Possible failures modes: Anisotropic face sheets under shear-loading.....	87

Figure 6-4: Core strength: Deviation (%) of actual strength from guaranteed values	90
Figure 7-1: Potting geometry	99
Figure 7-2: Effective potting radius as a function of insert diameter	102
Figure 7-3: Real potting radius as a function of insert diameter	104
Figure 7-4: Potting height as a function of the honeycomb core height	106
Figure 7-5: Mean weight of potting masses versus core height and insert diameter	107
Figure 7-6: Correction coefficient for weight of insert heights	108
Figure 8-1: Schematic of structural sandwich panel subjected to both in-plane and out-of-plane external loading	110
Figure 8-2: Sign conventions for sandwich beam element.....	112
Figure 8-3: Deformed sandwich beam element: deflection contributions from both bending and shearing	113
Figure 8-4 Shearing deformation of sandwich beam element.....	114
Figure 8-5: Failure modes: Honeycomb core sandwich panels	116
Figure 8-6: Schematic of 'local' bending effects in sandwich beam subjected to 3-point bending	118
Figure 8-7: Schematic of potted insert types for sandwich panels used for spacecraft applications.....	121
Figure 8-8: Model definition of sandwich plate with 'through-the-thickness' insert.....	122
Figure 8-9: Example: Lateral displacements of a symmetric sandwich plate with insert subjected to compressive out-of-plane load	124
Figure 8-10: Example: Core stress components of symmetric sandwich plate with insert subjected to out-of-plane compressive force	125
Figure 8-11: Example: Radial bending moment resultants in face sheets of symmetric sandwich plate with insert subjected to out-of-plane compressive force	127
Figure 9-1: Basic aspects of insert design, analysis and testing.....	136
Figure 9-2: Insert load cases.....	137
Figure 9-3: Insert out-of-plane load	137
Figure 9-4: Insert in-plane load	138
Figure 10-1: Typical insert arrangements.....	140
Figure 10-2: Insert load conditions	142
Figure 10-3: Sandwich panel with metallic face sheets: General design rules	144
Figure 10-4: Insert design under in-plane load.....	145
Figure 10-5: Insert design loaded by moments	145
Figure 10-6: CFRP face sheets: Effect of small chamfer on insert flange on load transfer to face sheet	146
Figure 10-7: Insert mounting modes	148
Figure 10-8: Connections	150
Figure 10-9: Selection of inserts: Partially potted.....	153
Figure 10-10: Selection of inserts: Through-the-thickness.....	153

Figure 10-11: Pre-design: Through-the-thickness insert under bending	157
Figure 10-12: Pre-design: Face sheet shear-out failure mode	158
Figure 10-13: Pre-design: Through-the-thickness insert under transverse force	159
Figure 10-14: Failure modes: Moment load	160
Figure 10-15: Failure modes: Load transfer in out-of-plane case	161
Figure 10-16: Failure modes: Insert as a function of core height	162
Figure 10-17: Failure modes: Non-correlation between number of the filled cells and number of the failing cell walls	163
Figure 10-18: Failure modes: Unsymmetrical potting and crossed cell	164
Figure 10-19: Failure modes: In-plane and torsion loads	165
Figure 10-20: Failure modes: CFRP face sheets	166
Figure 11-1: Flow chart: Predefined sandwich and loads	169
Figure 11-2: Flow chart: Variable main parameters	170
Figure 12-1: Failure modes in relation to the core height	173
Figure 12-2: Out-of-plane capability: Contributions of the main components on improved core shear	179
Figure 12-3: Out-of-plane capability: Contributions of the main components on improved core tension	180
Figure 12-4: Influence of insert height on insert capability	185
Figure 13-1: Compressive strength: Protruding insert	189
Figure 14-1: Shear-loaded inserts: Clamping conditions	190
Figure 14-2: Correlation between calculated and tested in-plane capabilities with fibre orientation	193
Figure 14-3: Correlation between calculated and tested in-plane capabilities with fibre strength	194
Figure 14-4: Nomenclature: Ultimate in-plane load against failure in tension	196
Figure 14-5: Shear strength: Stress concentration factor	197
Figure 14-6: Shear strength: Failure angle	198
Figure 14-7: Shear strength: Critical stresses for intracellular buckling (dimpling) under uniaxial compression	199
Figure 14-8: Shear strength: Influence of edge distance	201
Figure 14-9: In-plane capability: Contributions of the main components on improved core shear	202
Figure 15-1: Inserts loaded in bending: Clamping conditions	205
Figure 15-2: Bending load: Schematic of load-transfer	206
Figure 15-3: Bending load: Insert footprint on moment loading	207
Figure 16-1: Torsional load: Nomenclature	209
Figure 17-1: Insert submitted to an inclined load	211
Figure 18-1: Edge distance: Effect on insert static strength capability	215

Figure 19-1: Insert groups: Reduced insert capability - two adjacent inserts loaded in the same direction	220
Figure 19-2: Insert groups: Series of inserts loaded in same direction	222
Figure 19-3: Insert groups: series of inserts loaded in opposite directions	223
Figure 19-4: Insert groups: Interference coefficient for a group of equal and equidistant inserts	225
Figure 21-1: Static strength values with core height	233
Figure 21-2: Schematic: Design load spectrum	236
Figure 21-3: Insert fatigue life: Insert diameter 9 mm.....	243
Figure 21-4: Insert fatigue life: Insert diameter 11 mm.....	245
Figure 21-5: Insert fatigue life: Insert diameter 14 mm.....	247
Figure 21-6: Insert fatigue life: Insert diameter 17.5 mm.....	249
Figure 21-7: Insert fatigue life: Insert diameter 22.5 mm.....	251
Figure 21-8: Fatigue life: Non-metallic GFRP core	253
Figure 21-9: Fatigue life: Non-metallic Nomex [®] core	254
Figure 22-1: Thermal effects: Reduction of insert capability	257
Figure 22-2: Thermal effects: Reduction of potting resin strength	258
Figure 22-3: Thermal effects: Coefficient of thermal degradation	259
Figure 23-1: Basic manufacturing sequence.....	263
Figure 23-2: Inserts with connected potting mass.....	264
Figure 23-3: Venting of non-perforated core	265
Figure 23-4: Reference sample: Pull-out strength test specimen	270
Figure 23-5: Insert repair: Geometry	272
Figure 24-1: Sandwich panel machining: Combined drill and punch tool.....	279
Figure 24-2: Sandwich panel machining: Series of single tools and their uses	280
Figure 27-1: Manufacture control: Out-of-plane test fixture for tension (pull-out) tests	295
Figure 27-2: Manufacture control: Out-of-plane test fixture for compression or fatigue tests	296
Figure 27-3: Manufacture control: In-plane test fixture for shear Bending test	297
Figure 27-4: Manufacture control: Bending test fixture	298
Figure 27-5: Manufacture control: Torsion test fixture.....	298
Figure 28-1: QA: Poor potting causing strength degradation	304
Figure 28-2: QA: Honeycomb core - incoming inspection.....	307
Figure 28-3: QA: Core density correction factor for degree of expansion	308
Figure 29-1: Testing: Insert static out-of-plane strength fixture	311
Figure 29-2: Testing: Insert static in-plane strength fixture	312
Figure 29-3: Testing: ASTM insert static in-plane strength fixture	313
Figure 29-4: Testing: Bending fixture	314

Figure 29-5: Testing: Edge distance fixture.....	315
Figure 29-6: Testing: Insert proximity tensile fixture.....	316
Figure 29-7: Testing: Insert proximity tensile-compression fixture	316
Figure 29-8: Testing: Determination of points for residual strength test.....	318
Figure A-1 : Carbon fibre tube inserts: Comparison of design principles	323
Figure A-2 : Carbon fibre tube inserts: Fitting of spreadable CFRP tube	324
Figure A-3 : Carbon fibre tube insert: Type 1 cap	325
Figure A-4 : Carbon fibre tube insert: Type 2 cap	325
Figure A-5 : Carbon fibre tube insert: Type 2 insert cap and carbon fibre sleeve	326
Figure C-1 : Fully potted insert.....	333
Figure C-2 : Partially potted insert.....	336
Figure D-1 Out-of-plane loading: Circular sandwich plate with through-the-thickness insert.....	346
Figure D-2 : Partially potted insert: out-of-plane loading	349
Figure E-1 : Manufacture control: Insert tensile pull-out test fixture	364
Figure F-1 : Case study: ARIANE 1 equipment bay / ASAP 4 - tensile (pull-out) test method.....	376
Figure F-2 : Case study: ARIANE 4 Case 1	378
Figure F-3 : Case study: ARIANE 4 Case 2	379
Figure F-4 : Case study: ARIANE 4 - tensile (pull-out) test method.....	380
Figure F-5 : Case study: ARIANE 4 - shear test method	380
Figure F-6 : Case study: ASAP 4 (AR4) 1	384
Figure F-7 : Case study: ASAP 4 (AR4) 2.....	384
Figure F-8 : Case study: ASAP 4 (AR4) - tensile (pull-out) method A.....	385
Figure F-9 : Case study: ASAP 4 (AR4) - tensile (pull-out) method B.....	386
Figure F-10 : Case study: ASAP 5	389
Figure F-11 : ROSETTA Lander: Two structural components	392
Figure F-12 : ROSETTA Lander: Tension-compression, shear, bending and torsion tests	393
Figure F-13 : Carbon fibre tube insert (type 2): With cap for unilateral fixing.....	396
Figure F-14 : Carbon fibre tube inserts: Definition of the critical insert failure load, F_c	397
Figure F-15 : Case study: SPOT 5 - Case	399
Figure F-16 : Case study: SPOT 5 - Structure I/F platform	400
Figure F-17 : Case study: UMS - SST 1.....	402
Figure F-18 : Case study: UMS - SST 2.....	402
Figure F-19 : Case study: SILEX - insert.....	404
Figure F-20 : Case study: SILEX GEO MPCS – insert	405

Figure F-21 : Case study: HRG - Insert.....	411
Figure F-22 : Case study: HRG - Test method.....	413
Figure F-23 : Case study: NILESAT battery 1	415
Figure F-24 : Case study: NILESAT battery 2.....	416
Figure F-25 : Example: Insert verification – dimensions	417
Figure H-1 : Test fixture: Tension-compression load – master drawing.....	438
Figure H-2 : Test fixture: Tension-compression load – part 1	439
Figure H-3 : Test fixture: Tension-compression load – part 2	440
Figure H-4 : Test fixture: Tension-compression load – part 3	441
Figure H-5 : Test fixture: Tension-compression load – part 4	442
Figure H-6 : Test fixture: Tension-compression load – part 5	443
Figure H-7 : Test fixture: Tension-compression load – part 6	444
Figure H-8 : Test fixture: Tension-compression load – part 7	445
Figure H-9 : Test fixture: In-plane shear load – master drawing	446
Figure H-10 : Test fixture: In-plane shear load – part 1.....	447
Figure H-11 : Test fixture: In-plane shear load – part 2.....	448
Figure H-12 : Test fixture: In-plane shear load – part 3.....	449
Figure H-13 : Test fixture: In-plane shear load – part 4.....	450
Figure H-14 : Test fixture: In-plane shear load – part 5.....	451
Figure H-15 : Test fixture: In-plane shear load – part 6.....	452
Figure H-16 : Test fixture: In-plane shear load – part 7.....	453
Figure H-17 : Test fixture: In-plane shear load – part 8.....	454
Figure H-18 : Test fixture: Bending – master drawing.....	456
Figure H-19 : Test fixture: Bending – part 1	457
Figure H-20 : Test fixture: Bending – part 2	458
Figure H-21 : Test fixture: Bending – part 3	459
Figure H-22 : Test fixture: Bending – part 4	460
Figure H-23 : Test fixture: Bending – part 5	461
Figure H-24 : Test fixture: Bending – part 6	462
Figure H-25 : Test fixture: Bending – part 7	463
Figure H-26 : Test fixture: Bending – part 8	464
Figure H-27 : Test fixture: Bending – part 9	465
Figure H-28 : Test fixture: Bending – part 10	466
Figure H-29 : Test fixture: Bending – parts 11, 12 and 13	467
Figure H-30 : Test fixture: Bending – part 14	468
Figure H-31 : Test fixture: Torsion – master drawing.....	470
Figure H-32 : Test fixture: Torsion – part 1	471

Figure H-33 : Test fixture: Torsion – part 2	472
Figure H-34 : Test fixture: Torsion – part 3	473
Figure H-35 : Test fixture: Torsion – part 4	474
Figure H-36 : Test fixture: Torsion – part 5	475
Figure H-37 : Test fixture: Torsion – part 6	476
Figure H-38 : Test fixture: Torsion – part 7	477
Figure H-39 : Test fixture: Torsion – part 8	478
Figure H-40 : Test fixture: Torsion – part 9	479
Figure H-41 : Test fixture: Torsion – part 10	480
Figure H-42 : Test fixture: Torsion – part 11	481
Figure H-43 : Test fixture: Torsion – part 12	482
Figure H-44 : Test fixture: Torsion – part 13	483
Figure H-45 : Test fixture: Torsion – part 14	484
Figure H-46 : Test fixture: Torsion – part 15	485
Figure H-47 : Test fixture: Torsion – part 16	486
Figure H-48 : Test fixture: Torsion – part 17	487

Tables

Table 4-1: Insert system: General definition.....	68
Table 5-1: Types of inserts.....	71
Table 5-2: Potting methods	73
Table 5-3: List of insert standards	75
Table 5-4: Inserts: Aluminium alloy 'equivalents'.....	79
Table 5-5: Typical insert materials and surface protection.....	81
Table 6-1: Effect of sandwich components on insert load-bearing capability.....	83
Table 6-2: Failure mode and shear-load capability of tested CFRP face sheets	88
Table 6-3: Mechanical properties of common aluminium alloy hexagonal-type cores	91
Table 6-4: Mechanical properties of common non-metallic hexagonal-type cores	92
Table 7-1: Example: Insert potting compounds for space applications	97
Table 7-2: Example: Effect of increased potting radius on insert tensile capability.....	100
Table 9-1: Summary of the basic insert design parameters.....	135
Table 10-1: Failure modes of insert joint	160
Table 12-1: Properties for determining potted insert capability: Tensile load.....	176
Table 12-2: Perforated cores: Effective and real potting radius versus insert diameter.....	177
Table 12-3: Non-perforated cores: Effective and real potting radius versus insert diameter.....	177
Table 12-4: Out-of-plane capability: Effect of components on core shear	179



Table 12-5: Out-of-plane capability: Effect of components on core tension	179
Table 14-1: In-plane capability: Effect of components on core shear	201
Table 20-1: Insert stiffness: SILEX test configuration	229
Table 20-2: Insert stiffness: Comparison of analysis and test.....	230
Table 21-1: Fatigue: Stress concentration factors for local stress	235
Table 21-2: Fatigue: Coefficients to determine peak load.....	240
Table 21-3: Links to fatigue life data	241
Table 21-4: Insert diameter 9 mm: Fatigue correction factors.....	242
Table 21-5: Insert diameter 11 mm: Fatigue correction factors.....	244
Table 21-6: Insert diameter 14 mm: Fatigue correction factors.....	246
Table 21-7: Insert diameter 17.5 mm: Fatigue correction factors.....	248
Table 21-8: Insert diameter 22.5 mm: Fatigue correction factors.....	250
Table 23-1: Insert capability: Effect of poor storage of potting compound	273
Table 23-2: Insert capability: Effect of poor distribution of potting compound.....	275
Table 23-3: Insert capability: Effect of poor positioning of insert.....	275
Table 23-4: Insert capability: Effect of oversized bore hole.....	276
Table 26-1: Incoming inspection: Potting resin strength tests.....	291
Table 28-1: QA: Potting failure and detectability	304
Table 29-1: Testing: Dynamic test load levels and number of cycles	317
Table A-1 : Commercially available inserts used in space	320
Table A-2 : Non standard inserts used in space applications	322
Table B-1 : Core height: Permissible tensile loads - transition points	329
Table B-2 : Core height: Example - permissible tensile loads.....	329
Table B-3 : Design graphs: Index to permissible static loads.....	330
Table C-1 : Correlation coefficients	342
Table C-2 : Reliability coefficients	343
Table D-1 : Correlation coefficients	357
Table D-2 : Reliability coefficients	357
Table E-1 : IATP: Materials	363
Table E-2 : IATP: Shear test panel configurations	365
Table E-3 : IATP: Pull-out test panel configurations.....	366
Table E-4 : IATP: Shear test data	367
Table E-5 : IATP: Pull-out test data.....	369
Table E-6 : IATP: Shear test results versus design allowables.....	371
Table E-7 : IATP : Pull-out test results versus design allowables	372
Table F-1 : Case study: ARIANE 1 equipment bay/ASAP 4 – Allowable tensile load.....	376



Table F-2 : Case study: ARIANE 4 – materials and configuration	377
Table F-3 : Case study: ARIANE 4 equipment bay - Allowable tensile load	381
Table F-4 : Case study: ARIANE 4 equipment bay - Allowable shear load.....	382
Table F-5 : Case study: ASAP 4 – materials and configuration	383
Table F-6 : Case study: ASAP 4 - interference and edge effects.....	387
Table F-7 : Case study: ASAP 5 – materials and configuration	388
Table F-8 : Case study: ASAP 5 - Allowable tensile load.....	390
Table F-9 : Case study: ASAP 5 - interference and edge effects.....	391
Table F-10 : Carbon fibre tube inserts: Out-of-plane tension	395
Table F-11 : Carbon fibre tube inserts: Out-of-plane compression	395
Table F-12 : Carbon fibre tube inserts: In-plane shear load.....	396
Table F-13 : Carbon fibre inserts: Weibull analysis criteria	397
Table F-14 : Case study: SPOT 5 – materials and configuration	398
Table F-15 : No details given, [29-29]. Case study: UMS – Materials and configuration	401
Table F-16 : Case study: SILEX – Materials and configuration.....	403
Table F-17 :Case study: SILEX - Allowable tensile load	406
Table F-18 : Case study: SILEX - Allowable shear load	407
Table F-19 : Case study: SILEX - Allowable bending moment	408
Table F-20 : Case study: SILEX - Allowable torsion moment	409
Table F-21 : Case study: HRG – Materials and configuration.....	410
Table F-22 : Case study: HRG - Tensile load	412
Table F-23 : Case study: NILESAT – materials and configuration.....	414

1 Scope

The ECSS-HB-32-22A recommends engineering inserts and practices for European programs and projects. It may be cited in contracts and program documents as a reference for guidance to meet specific program/project needs.

The target users of this handbook are engineers involved in the design, analysis and verification of launchers and spacecraft in relation to insert usage. The current know-how is documented in this handbook in order to make expertise to all European developers of space systems.

It is a guidelines document, therefore it includes advisory information rather than requirements.

2 References

Due to the structure of the document, each clause at its end contains the list of reference called upon.

3

Terms, definitions and abbreviated terms

The following provides an explanation of the terms, acronyms and abbreviations used in this ECSS handbook; they are not definitions. Terms are listed in alphabetical order and interposed with explanations of the acronyms and abbreviations used in the handbook.

A

AA

Aluminium Association, USA

A-BASIS DESIGN ALLOWABLE (A-value)

mechanical property value above which at least 99 % of the population of values is expected to fall, with a confidence level of 95 %

[ECSS-E-ST-32]

ADHEREND

Plate adhesively bonded to another plate

[ECSS-Q-70-71]

ADHESION

The state in which two surfaces are held together at an interface by forces or the interlocking action of an adhesive or both

ADHESIVE

A substance capable of holding two surfaces together

NOTE: Used to retain carbon-fibre tube inserts in sandwich panels instead of the conventional potting compounds used for standard-types of inserts

ADHESIVE (FILM)

A synthetic resin adhesive, usually of the thermosetting type in the form of a thin film of resin with or without a fibrous carrier or support; used for bonding the face sheets of sandwich panels to the core

NOTE: Film adhesives usually have some tack to enable their placement during assembly.

ADHESIVE (FOAMING)

A synthetic resin adhesive, usually of the thermosetting type which when cured produces a foam-like material. [See: ADHESIVE (SYNTACTIC)]

ADHESIVE (SYNTACTIC)

A synthetic resin adhesive, usually of the thermosetting type that contains a hollow filler material, often in the form of small glass microballoons, which when cured produces a foam-like material

NOTE: These types of materials are widely used as a potting compound for retaining inserts in sandwich panels.

AECMA

Association Européen des Constructeurs Matériel Aérospatiale; European Association of Aerospace Industries

AFNOR

Association Français de Normalisation; French national standards organisation

AIR

French standards organisation

AISI

American Iron and Steel Institute, USA

ALLOWABLE LOAD

maximum load that can be permitted in a structural part for a given operating environment to prevent rupture, collapse, detrimental deformation or unacceptable crack growth [ECSS-P-001]]

ALLOWABLE STRESS

The maximum stress that can be permitted in a structural part for a given operating environment to prevent rupture, collapse, detrimental deformation or unacceptable crack growth [ECSS-P-001]

ALLOWABLES

Material values that are determined from test data at the laminate or lamina level on a probability basis (e.g. 'A' or 'B' values), following ASTM or other test standards accepted by the final customer. [See also: A-BASIS DESIGN ALLOWABLE; B-BASIS DESIGN ALLOWABLE; 'A' VALUE, 'B' VALUE]

ALLOY

Mixture of a base metallic element with one or more other metallic or non-metallic elements

ALODINE®

A proprietary chemical oxidising process, i.e. a non-electrolytic process, for surface treatment which results in an electrically conductive, chromated (mixed-metal, chromium-oxide) film, typically less than 1µm thick

ALUMINIUM (Al)

Metallic element, melting point 660°C, density 2700 kg m⁻³. Uses: ubiquitous aerospace alloy base, important component in oxidation resistant alloys and coatings and as part of basic strengthening mechanism for nickel-based superalloys

AMBIENT

- 1 The surrounding environmental conditions, e.g. pressure, temperature or relative humidity
- 2 usual work place temperature and humidity environmental conditions, e.g. room temperature

ANISOTROPIC

Having mechanical or physical properties which vary in direction relative to natural reference axes in the material

ARALDITE™

A range of epoxy-based structural adhesives; developed by Ciba Geigy, now Vantico

ARAMID

A type of highly oriented aromatic polymer material. Used primarily as a high-strength reinforcing fibre, of which Kevlar™ 49 and Twaron™ HM are most commonly used in aerospace applications

AREAL WEIGHT

A measurement of the weight per unit area of a fabric or fabric prepreg; expressed as g/m²

ARIANE

Family of European launch vehicles

ASTM

American Society for Testing and Materials; USA standards organisation

B

B-BASIS DESIGN ALLOWABLE (B-value)

mechanical property value above which at least 90 % of the population of values is expected to fall, with a confidence level of 95 %

[ECSS-E-ST-32]

BALANCED LAMINATE

Where plies with positive angles are balanced by equal plies with negative angles. While angle-ply laminates have only one pair of matched angles, balanced laminates can have many pairs, plus 0 and 90 degrees. A balanced laminate is orthotropic in in-plane behaviour, but anisotropic in flexural behaviour

BATCH

Materials produced during a unique sequence:

1. Fibre: The amount which is produced by the conversion of a number of precursor tows under standard, controlled, processing-plant conditions in one continuous operation, including any surface treatment and sizing of the fibre
2. Prepreg: A quantity, irrespective of width, that is produced under 'no-change conditions' in one continuous operation of the impregnating plant from one batch of resin mix and one batch of fibre. A batch is expected to conform to a fixed manufacturing process and to have homogeneous properties within prescribed tolerances over its whole width and length. A maximum allowable length for a prepreg batch is sometimes specified
3. Resin: A quantity of resin in either film or liquid form produced from one mix of resins, resin modifiers and curing agents

BIDIRECTIONAL LAMINATE

A reinforced plastic laminate with the fibres oriented in two directions in the plane of the laminate; a cross laminate. [See also: UNIDIRECTIONAL LAMINATE]

BLIND

Fasteners: Installed from one side of a component only

BOND LINE

The area between two materials that have been adhesively bonded; includes the layer of adhesive between the adherends

BORE HOLE

A hole machined in a sandwich panel of a suitable size to accept an insert

BS

British standard, controlled by the British Standards Institute (BSI)

BSI

British Standards Institute, UK

BUCKLING

1 Unstable displacement of a structural part, such as a panel, caused by excessive compression or shear. Micro-buckling of fibres in a composite material can also occur under axial compression

2 Fibre: a failure mechanism which occurs under compressive loads where the reinforcing fibres in a composite are displaced transversely; fibre buckling modes are known as 'extension mode' and 'shear mode'.

C

CADMIUM (Cd)

Metallic element, melting point 321 °C, density 8650 kg m⁻³, Uses: alloying additions, protective coatings: NOT FOR SPACE USE

CARBON/EPOXY

A composite material comprising of a carbon fibre reinforcement in an epoxy polymer matrix

CARBON FIBRE

Fibre produced by the pyrolysis of organic precursor fibres, such as rayon, polyacrylonitrile (PAN) and pitch, in an inert environment. The term is often used interchangeably with the term graphite; carbon fibres and graphite fibres do, however, differ. The basic differences lie in the temperature at which the fibres are made and heat-treated, and in the amount of elemental carbon produced. Carbon fibres typically are carbonised in the region of 1315°C and assayed at 93 to 95% carbon, while graphite fibres are graphitised at 1900°C to 2480°C and assayed at more than 99% elemental carbon

CARBON-FIBRE TUBE INSERT

A non-standard type of insert developed by DLR for the Rosetta Lander project, [See also: A.03; F.06]

CASA

Construcciones Aeronauticas SA, (E); now EADS CASA

CATALYST

A substance that changes the rate of a chemical reaction without itself undergoing permanent change in its composition; a substance that markedly speeds up the cure of a compound when added in a quantity small compared with the amounts of primary reactants

CEN

Comité Européen de Normalisation (European Committee for Standardization)

CFRP

Carbon fibre-reinforced plastic. Letter G in this handbook stands for Glass, whereas in American publications it is used for graphite. [See also: GFRP]

CIS

standards organisation, Russia

CO-CURE

Simultaneous curing and bonding of a composite laminate to another material or parts, such as honeycomb core or stiffeners, either by using the adhesive properties of the composite resin or by incorporating an adhesive into the composite lay-up

COLLECTED VOLATILE CONDENSABLE MATERIAL (CVCM)

quantity of outgassed matter from a test specimen that condenses on a collector maintained at a specific temperature for a specific time

NOTE: CVCM is expressed as a percentage of the initial specimen mass and is calculated from the condensate mass determined from the difference in mass of the collector plate before and after the test.

[ECSS-Q-ST-70-02]

COMPOSITE SANDWICH CONSTRUCTION

panels composed of a lightweight core material, such as honeycomb, foamed plastic, and so forth, to which two relatively thin, dense, high-strength or high-stiffness faces or skins are adhered

[ECSS-E-ST-32-08]

CORE

1 A lightweight material in between the face sheets of a sandwich panel, e.g. honeycomb core, foam. Metallic or composite sheet materials are bonded to the core to form a sandwich panel

2 Cores are often classed as either metallic or non-metallic and are commercially-available in a wide range of materials and configurations, e.g. honeycomb with a range of cell sizes and foil thicknesses, with or without perforations

CORE (HEXAGONAL)

A core material in which the shape of the individual cells is hexagonal

CORE (METALLIC)

Any core that is made of metal, e.g. often made of an aluminium alloy

CORE (NON-METALLIC)

Any core that is made of a material other than metal; usually made of glass-reinforced plastic (GFRP) or Nomex® for space applications

CORE (NON-PERFORATED)

A core material in which each of the cells is not connected to its neighbours; air trapped with the cells of a sandwich panel cannot be vented easily when placed in vacuum

CORE (PERFORATED)

A core material in which each of the cells is connected to its neighbours by one or more small holes in the cell walls; enables the removal of air trapped with the cells of a sandwich panel when placed in vacuum

CORE SPLICE

A joint or the process of joining one type of core to another; usually achieved by adhesive bonding using an adhesive with gap-filling properties

CROSS-LINKING

1 Applied to polymer molecules, the setting-up of chemical links between the molecular chains. When extensive, as in most thermosetting resins, cross-linking makes one infusible super-molecule of all the chains

2 The chemical reaction that occurs in thermosetting polymers due to the heat applied during the cure

CROSS-PLY

Composites containing plies of material, normally prepreg, at angles of 0° and 90°

CROSS-PLY LAMINATE

Special laminate that contains only 0° and 90° plies. This bidirectional laminate is orthotropic and has nearly zero Poisson's ratio. The other simple bidirectional laminate is the angle-ply, which possesses one pair of balanced off-axis plies

CTE

See: COEFFICIENT OF THERMAL EXPANSION

CTE MISMATCH

- 1 difference in coefficient of thermal expansion between two or more materials within a specified temperature change, e.g. polymers and metals. [ECSS-Q-70-71]
- 2 The difference in coefficient of thermal expansion between a reinforcement and the matrix or a coating and substrate within a specified temperature rise, e.g. carbon fibre (low/zero CTE) and Al alloy (large +ve CTE)

CURE

- 1 changing the properties of a polymer-based material by chemical reaction accomplished by heat or catalyst (or both) and with or without pressure, e.g. resin, adhesive, coating. [ECSS-Q-70-71]
- 2 chemical reaction during which a liquid resin is transformed to a solid material by the process of cross-linking

CURE CYCLE

- 1 period with a distinctive time, temperature and pressure profile to obtain specific properties of a polymer-based material, e.g. resin, adhesive, or coating. [ECSS-Q-70-71]
- 2 the cure cycle can include defined heat-up and cool-down rates, isothermal holds for specified periods and application and removal of negative or positive pressures at defined times or temperatures
- 3 potting compounds: Depends on the chemical formulation of the resin used for potting and if the resin or assembly can be cured at elevated temperature without causing damage; a typical cure cycle for potted inserts, using a two-part epoxy-based resin system, is several hours at room temperature

CURING TEMPERATURE

Temperature at which a cast, moulded or extruded product, a resin-impregnated reinforcement or an adhesive is subjected to curing

CURING TIME

The length of time a part is subjected to heat or pressure, or both, to cure the resin; interval of time between the instant relative movement between the moving parts of a mould ceases and the instant pressure is released

NOTE: Further cure can take place after removal of the assembly from the conditions of heat or pressure.[See: POST CURE]

CVCM

Collected Volatile Condensable Matter

CYCLIC LOADING

fluctuating load (or pressure) characterized by relative degrees of loading and unloading of a structure

NOTE For example, loads due to transient responses, vibro-acoustic excitation, flutter, pressure cycling and oscillating or reciprocating mechanical equipment.
[ECSS-E-ST-32-01]

D

DAMAGE

A structural degradation or anomaly caused by service conditions or by abnormal operation, e.g. impact damage caused by dropped tools or other foreign objects

DAMAGE TOLERANCE

The ability of a material, component or structure to retain an acceptable level of structural or environmental resistance properties under the effects of operational conditions, without risk of failing in a catastrophic manner, [See: DAMAGE TOLERANT]

DAMAGE TOLERANCE CONTROL

The application of design methodology, material and processing control, manufacturing technology, and quality assurance procedures to prevent premature structural failure due to the initiation or propagation of flaw or damage during fabrication, testing and service life

DAMAGE TOLERANT

characteristic of a structure for which the amount of general degradation or the size and distribution of local defects expected during operation, or both, do not lead to structural degradation below specified performance

ECSS-E-ST-32-01]

DAN

Deutsche Airbus-Norm; German Airbus standard

DEBOND

General: a defective area of an adhesive bond where the adherends are no longer held together. An area of separation within or between plies in a laminate, or within a bonded joint, caused by contamination, improper adhesion during processing, or damaging interlaminar stresses [See also: DELAMINATION]:

- 1 Adhesive bond: a delamination between the adherends
- 2 Sandwich panel: a delamination that occurs between the core and the face sheet; caused by contamination or damage to either the film adhesive used to join the face sheet laminate to the core, face sheet laminate itself, bond area of the core or mechanical damage to core cell walls, by crushing or more local damage

DEFECT

A manufacturing anomaly (crack, void, delamination) created by processing, fabrication or assembly procedures. [See also: FLAW]

DEGRADATION

reduction of material properties (e.g. mechanical, thermal or optical) that can result from deviations in manufacturing or from repeated loading or environmental exposure. [ECSS-Q-70-71]

DELAMINATION

Physical separation or loss of bond of the layers of material in a laminate; locally or over a wide area

DESIGN ALLOWABLE

Material values that are determined from test data at the laminate or lamina level on a probability basis (e.g. 'A' or 'B' values), following ASTM or other test standards accepted by the final customer. [See also: A-BASIS DESIGN ALLOWABLE; B-BASIS DESIGN ALLOWABLE; 'A' VALUE, 'B' VALUE]

DESIGN VALUES/ PROPERTIES

Material, structural-element and structural detail properties that have been determined from test data and chosen to assure a high degree of confidence in the integrity of the completed structure

DIELECTRIC

A material in which the electrical conductivity is zero or near zero

DIMPLING

Sandwich panels: the displacement under load of the face skins between the cellular structure of a honeycomb core

DIN

Deutsches Institut für Normung; German national standards organisation

DLR

Deutsches Zentrum für Luft- und Raumfahrt. German aerospace organisation

E

E-GLASS

Electrical glass; a grade of glass fibre. A borosilicate glass containing less than 1% alkali (combined sodium and potassium oxides); the type most used for glass fibres for reinforced plastics; suitable for electrical laminates because of its high resistivity

ECSS

European Cooperation for Space Standardization. A cooperative effort of the European Space Agency, National Space Agencies and European industry associations for the purpose of developing and maintaining common standards, [See: ECSS website: www.ecss.nl]

EDGE CLOSE-OUT

[See: EDGE CLOSURE]

EDGE CLOSURE

Sandwich panels: Protects the core from accidental damage, serves as a moisture seal and provides edge reinforcement to enable transfer and distribution of edge attachment loads; also known as 'edge close-out' and 'edge member'

EDGE MEMBER

[See: EDGE CLOSURE]

EDGE DISTANCE

The distance between an insert, or more precisely the centre line of the potting, and the edge of a sandwich panel

ELASTIC MODULUS

Stiffness

ELASTIC RELATION

Fully reversible, single-value, stress-strain relation. Loading and unloading follow the same path; there is no hysteresis, or residual strain. Although non-linear relation is admissible, the relation for composite materials is essentially linear

ELEMENT

- 1 A part of a more complex structural member, e.g. skin, stringers, shear panels, sandwich panels, joints or splices, Glossary Ref.[Ref-1]
- 2 A composite of subsystems, capable of performing an operational role only in conjunction with other elements, e.g. Space Vehicle, Ground Segment, Space Station Pressurised Module, Glossary Ref.[Ref-1]

ELONGATION

Deformation caused by stretching; the fractional increase in length of a material stressed in tension. (When expressed as percentage of the original gauge length, it is called percentage elongation)

EM ATV Cargo Carrier

Engineering model, Automated transfer vehicle integrated cargo carrier for ISS; International Space Station

EN

Euro Norme (European standard), [See: CEN]

ENN

ERNO-Norm; standard developed by MBB-ERNO (Bremen), now Astrium GmbH

ENVIRONMENT

External, non-accidental conditions (excluding mechanical loading), separately or in combination, that can be expected in service life and that can affect the structure, e.g. temperature, moisture, UV radiation and fuel

ENVISAT

Polar Platform ESA Polar Platform satellite to carry the Envisat-1 Earth-observation instruments. Designed to launch on Ariane-5 and use ESA's Data Relay Satellite system for the transmission of data to Earth.

EOS

Earth observation satellite

EPOXY

- 1 General: A family of thermosetting resins made by polymerisation of epoxides or oxiranes with other materials such as amines, alcohols, phenols, carboxylic acids, acid anhydrides, and unsaturated compounds; used for the matrix phase of composites and structural adhesives
- 2 Potting compounds: usually two-part epoxy resin systems combined with a suitable filler that, when cured, produces a foam-like material, [See also: ADHESIVE (SYNTACTIC)]

ESACOMP®

A software package for the analysis and design of composite laminates and laminated structural elements; developed for ESA/ESTEC by Helsinki University and distributed by Compoengineering Inc

ESTEC

European Space Research and Technology Centre, Noordwijk, NL

EXOTHERMIC

A type of chemical reaction that produces heat, e.g. can occur during the cross-linking, or curing, of polymer-based resins, such as epoxy

F

FABRIC

Any material of woven construction

FACE

- 1 Outer ply of a laminate.
- 2 Covering sheets of a sandwich panel

FACE SHEET

A composite laminate or metal sheet that forms the external surfaces of a sandwich panel

FACING

A sheet material, usually thin and made of composite or metal, that is attached to a core material to form a sandwich panel; also known as 'face sheet'

FACTOR OF SAFETY

The ratio of the design or ultimate loads to the limit or applied loads. [See: LOADS]

FAILURE (STRUCTURAL)

The rupture, collapse, seizure, excessive wear or any other phenomenon resulting in an inability to sustain limit loads, pressures and environments

[ECSS-E-ST-32]

FASTENER

item that joins other structural items and transfers loads from one to the other across a joint

[ECSS-E-ST-32-01]

FATIGUE

- 1 cumulative irreversible damage incurred by cyclic application of loads to materials and structures

NOTE 1 Fatigue can initiate and extend cracks, which degrade the strength of materials and structures.

NOTE 2 Examples of factors influencing fatigue behaviour of the material are the environment, surface condition and part dimensions.

[ECSS-E-ST-32-01]

- 2 Progressive cracking mechanism caused by alternating stress

FATIGUE LIFE

The number of cycles of deformation required to bring about failure of the test specimen under a given set of oscillating conditions

FATIGUE STRENGTH

- 1 The maximum cyclic stress a material can withstand for a given number of cycles before failure occurs
- 2 The residual strength of a material that has been subjected to fatigue

FATIGUE STRESS RATIO

The ratio of the minimum to the maximum fatigue stress, usually denoted by R

FAULT

Manufacturing: an error or departure from the intended specified process which results in a defective material or structure

FE

Finite element

FEA

Finite element analysis

FEM

Finite element model or modelling

FEDERAL

An American specification

FIBRE CONTENT

Percent volume of fibre in a composite material. Most common composites in use today have a fibre content between 45 volume % and 70 volume %. Percent weight of mass of fibre is also used

FIBRE-CONTROLLED

A laminate lay-up where the properties are largely determined by those of the fibre, e.g. $0^\circ/\pm 45^\circ/0^\circ/\pm 45^\circ/0^\circ$

FIBRE REINFORCED PLASTIC (FRP)

A fibre-reinforced thermosetting or thermoplastic polymer matrix composite material

FILLER

1 Fabric: Yarn oriented at right angles to the warp in a woven fabric; also known as fill, [See also: WEFT]

2 A material incorporated into a synthetic resin to modify the inherent viscosity and flow characteristics, e.g. usually in the form of glass microballoons for potting compounds used to embed inserts in sandwich panels

FILM ADHESIVE

A synthetic resin adhesive, usually of the thermosetting type in the form of a thin film of resin with or without a fibrous carrier or support.

NOTE: Film adhesives usually have some tack to enable their placement during assembly

FINISHING

Final manufacturing processes which result in a component ready for assembly. Often used to describe minor machining or cleaning operations

FLAW

A local discontinuity in a composite structure such as; a scratch, notch, crack, void, delamination, or debonding.

NOTE: Some fracture models also define a notch as a flaw, e.g. WEK [See also: DEFECT]

FLOW

1 The movement of resin under pressure, enabling all parts of a mould or cavity to be filled, e.g. flow of potting compound around an insert when injected into a bore hole.

2 Flow or creep is the gradual but continuous distortion of a material under continued load, often at elevated temperatures.

FLUSH (MOUNTED) INSERT

The positioning of an insert such that the upper surface of the insert is level, or flush, with the surface of the upper face sheet

FOAMING ADHESIVE

A synthetic resin adhesive, usually of the thermosetting type which when cured produces a foam-like material. [See: ADHESIVE (SYNTACTIC)]

FOOTPRINT

The area of the nut, collar or tail of an installed mechanical fastener that is in contact with the substrate material; bearing surface

FRP

Fibre-reinforced plastic

FULL POTTING

The maximum possible potting height is identical to the core height, c ; also known as blind or 'borne'

FULLY POTTED INSERT

An insert in which the potting material is in contact with the inside of the bottom face sheet,

G

GAUGE LENGTH

Part of a test specimen in which the characteristics of the material are determined; often instrumented with strain gauges, extensometers

GEL POINT

The stage at which a liquid begins to exhibit pseudo-elastic properties, also conveniently observed from the inflection point on a viscosity versus time plot

NOTE: Also called GEL TIME

GEL TIME

The exposure period required at a prescribed temperature to convert the resin from a fluid to a defined partial-cure stage

NOTE: Resin flow during cure can only occur substantially before gelling

GENERALISED HOOKE'S LAW

The most general linear elastic stress-strain relation for an anisotropic material from which materials with various types of symmetries can be derived

GFRP

Glass-fibre reinforced plastic

NOTE: In this handbook G = glass, but in US publications G = graphite. [See also: CFRP]

GLASS FIBRE

Reinforcement fibres of which E-, R- and S- grades are normally used in composites for aerospace applications

NOTE: E-glass: electrical grade; R and S: high-strength grades

GLASS TRANSITION TEMPERATURE (T_g)

The temperature at which increased molecular mobility results in significant changes in the properties of a cured resin system

GRP

Glass reinforced plastic; an industrial composite not a high-performance structural composite for aerospace applications, [See: GFRP]. Sometimes used for tabs on the ends of some composite test specimens

H

HARDENER

1 A substance or mixture added to a plastic composition to promote or control the curing action by taking part in it

2 A substance added to control the degree of hardness of the cured film [See also: CATALYST]

HEXAGONAL CORE

A core material in which the shape of the individual cells is hexagonal, e.g. aluminium honeycomb core

HIGH MODULUS CARBON FIBRES (HM)

A range of carbon fibres which have a tensile moduli greater than 310 GPa, typically

HIGH STRENGTH CARBON FIBRES (HS)

A range of carbon fibres which have tensile strengths up to 3500 MPa and tensile moduli in the range of 200 GPa to 255 GPa, typically

HIGH TENACITY CARBON FIBRES (HT)

A range of carbon fibres which includes HS high strength fibres and VHS very high strength fibres

HM

High modulus; a range of carbon fibres that also includes UHM ultra high modulus fibres

HONEYCOMB

Manufactured product of resin-impregnated sheet material (paper, glass or aramid-based fabric) or sheet metal formed into hexagonal-shaped cells; used as a core material in sandwich construction; also known as NIDA in Europe

HONEYCOMB SANDWICH

A sandwich construction in which the core material between the face sheets has a hexagonal cellular form that resembles honeycomb

HRG

'Haute Résolution Géométrique', the main payload of the SPOT 5 earth observation satellite

NOTE: The structure is similar to HRV and HRV-IR on SPOT 3 and SPOT 4, respectively.

HS

High strength; a range of carbon fibres

HT

High tenacity (high strength/high strain); a range of carbon fibres which includes HS high strength fibres and VHS very high strength fibres; also known as 'high tension'

HYGROSCOPIC

Tending to absorb moisture from the air

HYGROTHERMAL

The combination of moisture and temperature

I

IATP

Insert allowable test programme, conducted in two stages IATP-1 and IATP-2; an ESA-funded study

IDH

Insert design handbook

ILSS

Interlaminar shear strength

IM

- 1 Intermediate modulus; a range of carbon fibres that have tensile moduli in the range of 255 GPa to 310 GPa, typically
- 2 Integration Model

IN-HOUSE

A process or test standard created and used within a particular organisation; often considered as confidential and so not disclosed to other parties

INSERT

- 1 An integral part of a plastic moulding, consisting of metal or other material which can be moulded into position or pressed into the moulding after the moulding is complete
- 2 A fixing device or type of fastener system, commonly used in sandwich panels

INSERT (FLUSH)

An insert positioned such that its surface is level with that of the face sheet

INSERT (FLUSH-MOUNTED)

An insert positioned in a sandwich panel such that the upper surface of the insert is level, or flush, with the surface of the upper face sheet

INSERT (OVER-FLUSH)

An insert positioned above the surface of the face sheet; also known as 'protruding' insert

INSERT (PROTRUDING)

An insert positioned such that the end of the insert extends beyond the surface of the sandwich panel; also known as 'proud' or 'over-flush'

INSERT (SUB-FLUSH)

An insert positioned such that the end of the insert is below the surface of the face sheet; also known as 'recessed' insert

INSERT (THROUGH-THE-THICKNESS)

An insert which passes through the entire sandwich panel thickness also known as transverse, double-sided or spool.

INSERT (TYPE)

The various types of inserts can be grouped by the means that they are embedded into a sandwich panel:

- (A) for simultaneous bonding during sandwich production, also known as 'co-cure';
- (B) for an existing sandwich using either a thermosetting resin (usual potting process of standard inserts) or for non-standards inserts by an equivalent bonding process, e.g. carbon fibre tube inserts;

(C) for mechanical clamping or screwing into an existing sandwich.

INSPECTION

A verification method for physical characteristics that determines compliance with requirement without the use of special laboratory equipment, procedures, items or services. Inspection makes use of standard methods to verify requirements for construction features, document and drawing compliance, workmanship, physical conditions, Glossary Ref.[Ref-1]

INSPECTION PROCEDURE

This document lists all the requirements to be verified by Inspection, grouping them in categories detailing the Verification Plan activity sheets, with planning of the execution and a definition of the associated procedures, Glossary Ref.[Ref-1]

INSPECTION REPORT

This document describes each verification activity performed when inspecting hardware during manufacturing/integration and contains proper evidence that the relevant requirements are satisfied and the indication of any deviation, Glossary Ref.[Ref-1]

INTERLAMINAR SHEAR STRENGTH (ILSS)

The shear strength existing between layers of a laminated material

INTERMEDIATE MODULUS CARBON FIBRES (IM)

A range of carbon fibres with tensile moduli in the range of 255 GPa to 310 GPa, typically

IR

Infra Red

ISO

International standards organization

ISOTROPIC

Property that is not directionally dependent. [Having the same physical or mechanical properties in all material directions]. Metals are often assumed to be isotropic. This is normally not the case, but they do generally show considerably less anisotropy than fibre-reinforced composites

ISOTROP

[See: ISOTROPIC]

J

JIG

A fixture or tool that retains a material, sample or structure, e.g. for testing or during processing; also known as 'rig' or 'fixture'

JIS

Japanese Institute of Standards

K

K49

Kevlar™ 49

KEVLAR®

A grade of aramid fibre from E.I. Du Pont de Nemours [See also: ARAMID]

KFRP

Kevlar-fibre reinforced plastic

L

LAMINA

[See: PLY]

LAMINATE

Plate consisting of layers of uni- or multidirectional plies of one or more composite materials

LAY-UP

- 1 Hand- or machine-operated process of ply-by-ply laying of a multidirectional laminate
- 2 Ply-stacking sequence or ply orientations of a laminate

LIGHT ALLOY

General term for metal alloys of low density, e.g. aluminium, magnesium, which usually have high specific strengths (ratio of strength to density)

LIMITED SHELF LIFE

A period of time, usually stated by the manufacturer or supplier, that when elapsed means that a material can no longer be processed to produce consistently stable final properties, [See also: SHELF LIFE]

LIMIT LOAD

[See: LOADS]

LIMIT LOAD (LL)

maximum load(s), which a structure is expected to experience with a given probability, during the performance of specified missions in specified environments.

[ECSS-E-ST-32]

[See also: LOADS]

LIMIT STRESS

[See: LIMIT LOAD]

LINEAR ELASTIC FRACTURE MECHANICS (LEFM)

Engineering principle to describe the propagation of a single crack through a material, usually a metal alloy, in which it is assumed that all the material is behaving elastically

LN

Luft-Norm; a German standard

LOADS

Strength requirements are specified in terms of:

- 1 Limit Loads: The maximum external loads to be expected during operational use
- 2 Ultimate Loads: Limit loads multiplied by prescribed FACTORS OF SAFETY, e.g. the ultimate loads are often established by applying a factor of safety of 1,5 on limit loads

LOAD-DEFLECTION CURVE

A graphical representation of the extension of a material under an applied load; often recorded during the mechanical testing of a sample

LOAD-STRAIN CURVE

A graphical representation of the extension of a material under an applied load

M

MACHINING

removal of material in a controlled manner by one or more mechanical, electrical or chemical methods, e.g. turning, milling, drilling, electro-chemical discharge, and ultrasonic. [ECSS-Q-70-71]

MAN-MT

Part of the German MAN Technologie company

MARGIN OF SAFETY

Ratio of excess strength to the required (calculated) strength

MASS (of insert system)

Calculated by (potting mass + mass of insert components) – (mass of face sheet removed + mass of core removed)

MASS (of potting)

Describes the volume of cured potting compound used to retain a potted insert within a sandwich panel; also known as 'potting mass'

MATERIAL

raw, semi-finished or finished purchased item (gaseous, liquid, solid) of given characteristics from which processing into a functional element of the product is undertaken

[ECSS-P-001]

MATERIAL DESIGN ALLOWABLE

material property that has been determined from test data on a probability basis and has been chosen to assure a high degree of confidence in the integrity of the completed structure

[ECSS-E-ST-32-08]

MATHEMATICAL MODELLING

Analytical verification based on mathematical modelling of the system. Modelling is performed on the basis of known mathematical techniques, providing a representation of the system features under investigation, Glossary Ref.[Ref-1]

MBB ERNO

Part of the German MBB aerospace organisation located in Bremen. Original authors of the insert design handbook; now part of Astrium GmbH

MD

Multidirectional

MECHANICAL LOAD

Mechanically applied load, distinguished from cure or environment-induced load

MECHANICAL PART

piece of hardware which is not electrical, electronic or electromechanical, and which performs a simple elementary function or part of a function in such away that it can be evaluated as a whole against expected requirements of performance and cannot be disassembled without destroying this capability

[ECSS-P-001]

METALLIC CORE

Any core that is made of metal, e.g. often made of an aluminium alloy

MICROBALLOONS

A filler material made of very small, hollow glass spheres that is mixed into synthetic resins to modify the flow and viscosity characteristics of the resulting potting compounds; also known as 'microspheres'

MIL-A-81596

Aluminum foil for sandwich construction; USA specification

MIL-A-8625

Anodic coatings for aluminium and aluminium alloys; describes anodising processes for inserts; USA specification

MIL-C-5541

Chemical conversion processes on aluminium alloys; describes chromating processes for inserts; USA specification

MIL-C-7438

Core material - aluminum, for sandwich construction; USA specification

MIL-C-81986

Core Material - plastic honeycomb: nylon paper base for aircraft structural applications; USA specification

MIL-HDBK-17

Composite Materials Handbook; USA specification

MIL-HDBK-23

Structural Sandwich Composites; USA specification.

NOTE: MIL-HDBK 23 is under review for partial incorporation as Volume 6 of MIL-HDBK-17

MIL-HDBK-5

Metallic Materials and Elements for Aerospace Vehicle Structures; USA specification

MIL-standards and specifications

Information regarding current MIL-designation specifications (<http://store.mil-standards.com/>)

MODULUS

An elastic constant defined as the ratio between the applied stress and the related deformation, such as Young's modulus, shear modulus, or stiffness moduli in general

MOISTURE ABSORPTION

Moisture absorption causes the properties of epoxy to change; it can be detrimental in causing the glassy temperature of the epoxy to be suppressed, and beneficial by counteracting swelling during stresses

MOISTURE CONTENT

The amount of moisture in a material determined under prescribed conditions and usually expressed as a percentage of the mass of the moist specimen, i.e. the mass of the dry substance plus the moisture present

MOULD RELEASE AGENT

Lubricant applied to mould surfaces to facilitate release of the moulded part

M.S

Margin of safety

MULTIDIRECTIONAL

1 Having multiple ply orientations in a laminate

2 Composite laminates in which the properties are controlled by the orientation of the reinforcement fibres, i.e. fibre-controlled

N

NAS

National Aerospace standard

NDI

Non-destructive inspection, [See: NON DESTRUCTIVE]

NDT

Non-destructive testing, [See: NON DESTRUCTIVE]

NF

Norme Française; French national standard

NIDA

European term for 'honeycomb'; a type of core used in sandwich panels

NOMEX®

An aramid fibre blend from E.I. Dupont de Nemours. Used as the reinforcement material in non-metallic honeycomb cores for sandwich constructions

NON-ASSESSED PROCESS

A process that has no history of previous use in the space environment, and for which no or insufficient data are available relevant to the required project application

NON-METALLIC (CORE)

Any core material that is not made of metal. Core materials of sandwich panels used for space applications are normally made of Nomex® or glass-fibre reinforced plastic

NON DESTRUCTIVE

Techniques used to qualitatively evaluate or quantitatively measure properties or detect defects in materials, structural components or whole structures which do not cause a permanent change to the item under test, e.g. ultrasound, holography, eddy current. The terms NDI (inspection), NDT (testing), NDC (characterisation) and NDE (evaluation) tend to be interchangeable. Non-destructive inspection systems can be manually interpreted or automated to some extent. All require calibration, and the detection limit for each technique varies.

NOTE: No one technique is capable of detecting all types of defects.

NSA

Normalisation Sud Aviation; French standard

O

OFF-AXIS

Not coincident with the axis of symmetry

NOTE: Also called off-angle

OFFGASSING PRODUCT

organic or inorganic compound evolved from a material or assembled article or experiment or rack

[ECSS-Q-ST-70-29]

OFFGASSING

1 General: Depending on the application, there are restrictions on the gaseous products released from materials or finished articles in operational vacuum conditions that can:

- contaminate other equipment, [See also: OUTGASSING];
- contaminate the air during preparatory or operational conditions for manned spacecraft.

2 evolution of gaseous products for an assembled article subjected to slight radiant heat in the specified test atmosphere

[ECSS-Q-ST-70-29]

NOTE: It applies to materials and assembled articles to be used in a manned space vehicle crew compartment.

ON-AXIS

Coincident with the axis of symmetry; also known as 'on-angle', [See: ORTHOTROPIC]

ORTHOTROPIC

A description of material symmetry where the x-axis and y-axis of a laminate coincide with the longitudinal and transverse directions of the material; also known as 'on-axis'

ORTHOTROPY

Having three mutually perpendicular planes of symmetry. Unidirectional plies, fabric, cross-ply and angle-ply laminates are all orthotropic

ORTHOGONAL WEAVE

A fabric in which the warp and weft directions are 90° to each other

OUTGASSING

1 General: Depending on the application, there are restrictions on the gaseous products released from materials or finished articles in operational vacuum conditions that can:

- contaminate other equipment (outgassing)
- contaminate the air during preparatory or operational conditions for manned spacecraft,

[See also: OFFGASSING]

2 Release of gaseous species from a specimen under high vacuum conditions [ECSS-Q-ST-70-02]

P

PA

Product Assurance

PAN

Panavia standard

PART

hardware item that cannot be disassembled without destroying the capability to perform its required function

[ECSS-P-001]

PARTIAL POTTING

The potting height is generally smaller than the core height, c; also known as blind, 'borne' or single-sided

PARTIALLY POTTED INSERT

An insert in a sandwich panel in which there is some core remaining under the potted insert,

PASTE

Adhesive: a single- or two-component adhesive that often includes a thickening agent, such as microballoons, that behaves as a viscous liquid

PATRIA FINAVICOMP

Finnish aerospace and defence company

PEEL PLY

Sacrificial sheets of material, usually a fabric, applied to the external surfaces of composites; after processing peel plies are removed to provide a clean, contaminant-free surface

PERMISSIBLE LOAD

A load, proven by analysis and testing, with a known statistical confidence, that can be supported by a material or assembly without resulting in unacceptable damage or degradation throughout the intended period; also known as 'allowable' load

PLASTIC

A material that contains as an essential ingredient an organic substance of high molecular weight, is solid in its finished state, and at some stage in its manufacture or processing into finished articles can be shaped by flow; made of plastic

PLY

A single layer of a laminated stack of composite material (or a single pass for a filament-wound configuration)

PLY DROP

The position inside a laminate where a ply is terminated, e.g. to create a tapered thickness

PLY GROUP

Group formed by contiguous plies with the same angle

POISSON'S RATIO

The ratio between the extension (Strain) of an elastic material in the axial direction and the accompanying contractions in the transverse directions when uniaxial stress is applied.

NOTE: The transverse strain is a constant fraction of the strain in the longitudinal direction, e.g. for perfectly isotropic elastic materials, Poisson's ratio (x-axis) is 0,25, whereas most alloys have a value of about 0,33, Glossary Ref. [Ref-2]

POLYMER

high molecular weight organic compound, natural or synthetic, with a structure that can be represented by a repeated small unit, the mer

NOTE: E.g. polyethylene, rubber and cellulose

[ECSS-E-ST-32-08].

NOTE: Synthetic polymers are formed by addition or condensation polymerisation of monomers. Some polymers are elastomers, some plastics

POLYMERISATION

A chemical reaction in which the molecules of a monomer are linked together to form large molecules whose molecular weight is a multiple of that of the original substance

POSTCURE

An additional elevated-temperature cure, usually without pressure, to improve final properties or complete the cure. Complete cure and ultimate mechanical properties of certain resins are attained only by exposure of the cured resin to higher temperatures than those of curing

POT LIFE

length of time a catalysed resin system retains a viscosity low enough to be used in processing

NOTE: Also called 'Working Life'.

[ECSS-Q-70-71]

POTTED INSERT

An insert that is retained in a sandwich panel by a volume of cured potting compound

POTTED INSERT (CLASSICAL)

The usual means of incorporating a standard-type of insert into a sandwich panel using a potting process; also known as 'conventional potted insert'

POTTING

The process of embedding inserts into a sandwich panel using a potting compound

POTTING (FULL)

The maximum possible potting height is identical to the core height, c ; also known as blind or 'borne'

POTTING (MASS OF)

The volume of cured potting compound used to retain a potted insert within a sandwich panel

POTTING (PARTIAL)

The potting height is generally smaller than the core height, c ; also known as blind, 'borne' or single-sided

POTTING COMPOUND

A polymer resin system (base, hardener, catalyst) usually epoxy-based, that often contains a filler or thickening agent to modify the viscosity and flow characteristics; used for retaining inserts in sandwich panels

POTTING MASS

A calculated quantity determined from the core properties (height and cell size) and insert diameter and whether the insert is partially or fully potted

POTTING PROCESS

The sequence of operations by which inserts are embedded into sandwich panels, e.g. positioning of the insert in a machined hole, mixing of resin and adding the filler, injection into the sandwich panel, curing (usually several hours at room temperature)

POTTING RESIN

A polymer-based resin system (base, hardener and catalyst) that is combined with a suitable filler (to modify the viscosity and flow characteristics) to form a potting compound suitable for potting of inserts into sandwich panels; usually an epoxy-based resin system

PREPREG

woven or unidirectional ply impregnated with a resin, usually advanced to B-stage, ready for lay-up or winding

NOTE: Short for "pre-impregnated".

[ECSS-Q-70-71]

prEN

Provisional or draft EN standard

PRIMER

A coating applied to a surface before the application of an adhesive, lacquer, paint, enamel or the like to improve the performance of the bond

PROCESS

set of interrelated or interacting activities which transform inputs into outputs

NOTE 1 Inputs to a process are generally outputs of other processes.

NOTE 2 Processes in an organization are generally planned and carried out under controlled conditions to add value.

NOTE 3 A process where the conformity of the resulting product cannot be readily or economically verified is frequently referred to as a "special process".

[ECSS-P-001]

PROOF TEST

test of flight hardware under the proof load or pressure, to give evidence of satisfactory workmanship and material quality or to establish the initial crack sizes in the hardware

[ECSS-E-ST-32]

PROTRUDING INSERT

An insert positioned such that the flange(s) of the insert protrudes beyond the sandwich panel surface; also known as 'proud' or 'over flush'

psi

Pounds per square inch

PSS-IDH

Refers to ESA-PSS-03-1202 Issue 1 Revision 1 (September 1990); a previous version of the insert design handbook

PVC

Polyvinylchloride

Q

QA

Quality assurance

QC

Quality control

QUALIFICATION

Verification phase with the objective to demonstrate that the design meets the applicable requirements including proper margins, Glossary Ref.[Ref-1]

QUASI-ISOTROPIC LAMINATE

A laminate approximating isotropy by orientation of plies in several or more directions

R

R-ratio

ratio of the minimum stress to maximum stress

[ECSS-E-ST-32-01]

RECESSED INSERT

An insert positioned below the surface of the face sheet; also known as 'sub-flush' insert

RECOVERED MASS LOSS (RML)

total mass loss of the specimen itself without the absorbed water

NOTE 1 The following equation holds:

$$\text{RML} = \text{TML} - \text{WVR}.$$

NOTE 2 The RML is introduced because water is not always seen as a critical contaminant in spacecraft materials.

[ECSS-Q-ST-70-02]

REFERENCE SAMPLE

Used to assess the potting process. A reference sample is produced using identical materials to the assembly (insert, face sheets, core, adhesive) at the same time as the manufactured assembly and undergoes all the same processes, e.g. machining, potting, curing; also known as 'witness sample'

REINFORCED PLASTIC

A plastic with strength properties greatly superior to those of the base resin, resulting from the presence of reinforcements embedded in the composition

REINFORCEMENT

A strong inert material bonded into a plastic, metal or ceramic to improve its strength, stiffness and impact resistance. Reinforcements are usually long fibres of glass, boron, graphite or aramid, in woven or non woven form. To be effective, the reinforcing material must form a strong adhesive bond with the matrix

NOTE: 'Reinforcement' is not synonymous with 'filler'.

RELATIVE HUMIDITY (RH)

A measure of the moisture content of an atmosphere with respect to the fully saturated atmosphere at the same temperature and pressure; expressed as a percentage

RELEASE AGENT

A material which is applied in a thin film to the surface of a mould to keep the resin from bonding to it

RELEASE FILM

A thin sheet of material applied to a composite surface to enable its removal from a mould; used in autoclave processing

REPAIR

Operations performed on a non-conforming item to place it in usable and acceptable condition according to an authorised repair procedure/standard. Repair is distinguished from rework

NOTE: Repair can consist of a component change with all its associated connections including the fixing down of a lifted pad or track.

RESIDUAL FATIGUE STRENGTH

The retention of static strength by a laminate that has been subjected to a certain fatigue-load history

RESIDUAL STRENGTH

The retention of static strength by a material or assembly that has been subjected to a load history or environment, e.g. cyclic mechanical loading (fatigue test); thermal cycling; thermal soak

RESIDUAL STRESS

- 1 A stress that remains in the material or structure, owing to processing, fabrication or prior loading
- 2 Composites: Resulting from cool-down after cure and change in moisture content. On the micromechanical level, stress is tensile in the resin and compressive in the fibre. On the macro-mechanical level, it is tensile in the transverse direction to the unidirectional fibres, and compressive in the longitudinal direction, resulting in a lowered first-ply-failure load. Moisture absorption offsets this detrimental thermal effect at both micro and macro levels
- 3 Metals: Usually arises from heat treatment or mechanical working

RESIN

A solid, semi-solid, or pseudo-solid organic material which has an indefinite (often high) molecular weight, exhibits a tendency to flow when subjected to stress, usually has a softening or melting range, and usually fractures conchoidally. Most resins are polymers. In reinforced plastics, the material used to bind together the reinforcement material, the matrix. [See also: POLYMER]

RESIN CONTENT

The amount of resin in a laminate expressed as a percent of total weight or total volume

RF

Radio frequency

R.F.

Reserve factor

R-GLASS

A high-strength grade of glass fibre, [See also: GLASS FIBRE]

RH

Relative humidity

RIG

A fixture or tool that retains a material, sample or structure, e.g. for testing and processing; also known as 'jig' or 'fixture'

RML

Recovered mass loss

RMS

Root mean square

ROSETTA

ESA comet rendezvous mission. Launched in March 2004, Rosetta will be the first mission ever to orbit and land on a comet. Following the decision not to launch Europe's comet chaser, Rosetta, in January 2003, scientists and engineers in the programme examined several alternative mission scenarios. Each was judged on the basis of the expected scientific return, the technical risks related to using the Rosetta design in the new mission. In May 2003, Rosetta was provided with a new target (<http://www.esa.int/science/rosetta>)

RT

Room temperature

RULE OF MIXTURES

Linear volume fraction relation between the composite and the corresponding constituent properties; also known as 'Law of Mixtures' e.g. For modulus of a composite E_c , the rule of mixtures equation is:

$$E_c = E_f V_f + E_m V_m$$

where:

E_f = modulus of the fibre

V_f = volume fraction of fibre in the composite

E_m = modulus of the matrix

V_m = volume fraction of the matrix

S

SANDWICH

1 Construction: An assembly composed of a lightweight core material, such as honeycomb, foamed plastic, and so forth, to which two relatively thin, dense, high-strength or high-stiffness faces or skins are adhered, [See also: FACE SHEET]

2 Panel: A sandwich construction of a specified dimensions

NOTE: The honeycomb and face skins can be made of composite material or metal alloy.

SATELLITE

An unmanned spacecraft generally oriented to scientific, telecommunication, earth observation missions, Glossary Ref.[Ref-1]

SCOTCHLITE™

A proprietary brand of glass microballoons, manufactured and supplied by 3M

SD

Standard deviation; a statistically-derived quantity

SECONDARY BONDING

A process whereby manufactured component parts are joined by an adhesive; can be applied to composite parts that have already been cured or metal parts or combinations thereof

NOTE: This is different from co-curing, [See also: CO-CURING].

SERVICE CONDITIONS

The combination of mechanical loading and environmental effects experienced by a material, component or structure in operation over its intended life

SERVICE LIFE

interval beginning with the last item inspection or flaw screening proof test after manufacturing, and ending with completion of its specified life

[ECSS-E-ST-32]

S-GLASS

A magnesia-alumina-silicate glass, especially designed to provide filaments with very high tensile strength

SHEAR MODULUS RATIO

Ratio of the shear modulus of the core material to that of the face sheet in a sandwich construction

SHELF LIFE

- 1 stated time period in which the manufacturer guarantees the properties or characteristics of a product for the stated storage conditions, [ECSS-Q-70-71]
- 2 Period of time during which a material can be processed to produce final properties with consistently stable parameters, [ECSS-Q-ST-70-22]

SHELF LIFE (LIMITED)

A period of time, usually stated by the manufacturer or supplier, that when elapsed means that a material can no longer be processed to produce consistently stable final properties, [See also: SHELF LIFE]

SHOP LIFE

The shop life of a prepreg is that period following removal from the specified storage conditions and attaining shop-floor temperature for which the prepreg remains workable in terms of tack, and flow and cure characteristics

SHUR-LOK®

Manufacturer and supplier of standard types of inserts and a commonly-used potting resin

SI

The international system of units, published by the International Standards Organisation (ISO)

SILEX

'Semiconductor laser inter-satellite link experiment'. The ESA-developed SILEX terminal on board the Artemis satellite has enabled it to receive picture data from the French Spot-4 satellite via laser

SKIN

A sheet of material applied to outside surface of a core in order to make a sandwich panel; also known as 'face sheet' and 'face skin'

SMH

Structural materials handbook; ECSS-E-HB-32-20

S-N CURVE

Stress per number of cycles to failure; a graph used to display fatigue testing results

SPACECRAFT

A space system which could be either manned or unmanned and could have any type of mission objectives, i.e. telecommunications, transportation, earth observation, interplanetary exploration, Glossary Ref.[Ref-1]

SPACE-PROVEN MATERIAL OR MECHANICAL PART

One whose properties are well understood and that is produced by means of a stable process, usually confirmed by a history of continuous or frequent production runs. It must be compliant with a recognised set of specifications. It will have been used in space applications, or will have successfully completed an appropriate evaluation process

SPECIFIC GRAVITY (SG)

A dimensionless quantity also known as Relative Density. Ratio between the density of a material and that of water under standard conditions

SPECIFIC STIFFNESS

The measure of the stiffness of a material with respect to its density

SPECIFIC STRENGTH

The measure of the strength of a material with respect to its density

SPOOL INSERT

Through-the-thickness insert

SPOT

A series of Earth observation satellites providing data for mapping, disaster management and controlling the environment

SPOT 5

The CNES SPOT 5 satellite was successfully placed into Sun-synchronous orbit in May 2002 by an Ariane 4 launcher. This, the fifth SPOT satellite to be launched, ensures the continuity of SPOT Earth observation data and provides even better high-resolution images

STACKING ORDER or SEQUENCE

Ply ordering in a laminate. Stacking sequence does not affect the in-plane properties of a symmetric laminate. Only the ply number and angles are important. But stacking sequence becomes critical for the flexural properties, and the interlaminar stresses for any laminate, symmetric or not; also known as 'lay-up'

STANDARD OR ESTABLISHED PROCESS

One that is well documented, has a previous history of use, is well understood and for which standard inspection procedures exist. Such a process would generally be covered by ECSS specifications or other international or national documents

STATIC FATIGUE

Failure of a part under continued static load; analogous to creep-rupture failure in metal testing, but often the result of ageing accelerated by stress

STIFFNESS

Ratio between the applied stress and the resulting strain. Young's modulus is the stiffness of a material subjected to uniaxial stress; shear modulus to shear stress. For composite materials, stiffness and other properties are dependent on the orientation of the material. [See: MODULUS]

STORAGE LIFE

The length of time that a material can be kept under predetermined conditions and not degrade, e.g. Prepreg: usually -18 °C for thermosetting resin systems, with subsequent factory floor operations at room temperature, [See also: SHELF LIFE]

STRAIN GAUGE

Widely used device for point measurement of strain. Usually thin film metals which, when strained, change in electrical resistance

NOTE: Require calibration and temperature compensation.

STRENGTH RATIO or STRENGTH/STRESS RATIO

Measure related to MARGIN OF SAFETY. Failure occurs when the ratio is unity; safety is assured for example by a factor of 2 if the ratio is 2. The ratio is particularly easy to obtain if the quadratic failure criterion is used

STRENGTH

Maximum stress that a material can sustain. Like the stiffness of a composite material, this is highly dependent on the direction as well as the sign of the applied stress; e.g. axial tensile, transverse compressive, and others

STRESS AMPLITUDE (R)

Fatigue test: the range of stresses induced in a laminate when a cyclic load is applied, [See also: R]

STRESS

Intensity of forces within a body. The normal components induce length or volume change; the shear component, shape change. The numerical value of each component changes as the reference co-ordinate system rotates. For every stress state there exists a principal direction, a unique direction when the normal components reach maximum and minimum, and the shear component vanishes

STRESS-STRAIN CURVE

A graphical representation of a material's response to increasing load. Often used to depict relationships between stress(load) and strain (elongation), e.g. stiffness, strength(s)and strain to failure

STRESS-STRAIN RELATION

A linear relation is usually assumed for calculating stress from strain, or strain from stress. For multidirectional laminates, it can be generalised to include in-plane stress-strain, and flexural stress-strain relations. All anisotropic relations are simple extensions of the isotropic relation

STRUCTURAL COMPONENT

A major section of the structure (e.g. wing, body, fin, horizontal stabiliser) that can be tested as a complete unit to qualify the structure

STRUCTURAL FAILURE

[See: FAILURE (STRUCTURAL)]

STRUCTURAL SUBCOMPONENT

A major three-dimensional structure that can provide complete structural representation of a section of the full structure (e.g. stub-box, section of spar, wing panel, wing rib, body panel or frames)

STRUCTURE

All items and assemblies designed to sustain loads or pressures, provide stiffness and stability, or provide support or containment

STYCAST®

A proprietary type of potting resin, produced by Emerson and Cumin

SUBASSEMBLY

A subdivision of an assembly consisting of two or more items

NOTE: Verification level typical of US standard, Glossary Ref.[Ref-1].

SUBSYSTEM

1 A functional subdivision of a payload consisting of two or more items

2 A set of functionally related equipment, connected to each other, that performs a single category of functions, e.g. structure, power, attitude control, thermal control, Glossary Ref.[Ref-1]

SWARF

Waste material, usually metallic, produced during machining processes

SYMMETRIC LAMINATE

Possessing mid-plane symmetry. This is the most common construction, because the curing stresses are also symmetric. The laminate does not twist when the temperature and moisture content change. An unsymmetrical laminate on the other hand twists on cooling down and untwists after absorbing moisture

SYNTACTIC

1 General: Highly-ordered

2 A potting compound containing a filler made of hollow glass microspheres that, when cured, has a foam-like structure, [See also: ADHESIVE (SYNTACTIC)]

SYSTEM

The composite of elements, skills and techniques capable of performing the operational roles. A system includes all operational equipment, related facilities, materials, software, services and personnel required for its operation, e.g. launch system, on-orbit system, Glossary Ref.[Ref-1]

T

T

Toxic hazard index

TAB

A material, usually fixed to each end of a test specimen, which enables load to be transferred to the test specimen without causing damage to the test specimen; composite test specimens often have light-alloy or glass-fibre based composite tabs adhesively bonded to the test specimen

TACK

Stickiness of a prepreg or film adhesive; an important handling characteristic

TAN

Transall-Norm; a specification

TEST

A verification method wherein requirements are verified by measurement of performance relative to functional, electrical, mechanical and thermal parameters. These measurements can require the use of special equipment, instrumentation and simulation techniques, Glossary Ref.[Ref-1]

TEST PROCEDURE

A document which provides detailed step-by-step instructions to the Test teams for conducting the test activities in agreement with the Test Specification requirements, Glossary Ref.[Ref-1]

TEST SPECIFICATION

A document prepared for each major test activity described in the Verification Plan task sheets with the objective to detail the test requirements, Ref.[Ref-1]

T_g

Glass transition temperature; the temperature at which a material changes from a glassy to ductile state, giving a steep increase in free volume

THERMAL CONDUCTIVITY

Ability of material to conduct heat; the physical constant for quantity of heat that passes through a unit cube of a substance in unit time when the difference in temperature of two faces is 1 degree

THERMAL CYCLING

The repeated change of temperature experienced by a material, component or structure; the maximum and minimum temperatures are normally those associated with orbiting the Earth

THERMAL EXPANSION

[See: COEFFICIENT OF THERMAL EXPANSION]

THERMAL LOAD (STRESS)

The structural load (or stress) arising from temperature gradients and differential thermal expansion between structural elements, assemblies, subassemblies or items

THERMAL SHOCK

Sudden and rapid change in temperature, usually over a large temperature range

THERMAL SOAK

A period of time that a material, component or structure is exposed to an elevated temperature, e.g. structures underneath thermal protection systems

THERMOCOUPLE

Device for measuring temperature consisting of two dissimilar conductors joined at their ends which, when heated, develop a characteristic EMF. The temperature is indicative of that of the junction of the pair in the thermocouple, i.e. a point measurement device.

NOTE: Calibration and compensation are required.

THERMOPLASTIC

Organic material, the stiffness of which can be reversibly changed by temperature change. One unique property of this material is its large strain capability, e.g. PEEK. On the other hand, processing requires higher temperatures and pressures than those for thermosetting plastics

THERMOSETTING

Organic material that can be converted to a solid body by cross-linking, accelerated by heat, catalyst, ultraviolet light, and others. This is the most popular type of material for the matrix phase of composite materials, adhesives and potting resins, [See also: EPOXY]

THROUGH-THE-THICKNESS INSERT

An insert which passes through the entire sandwich panel thickness, also known as 'transverse', 'double-sided', 'spool' or 'thru'-spool'

TITANIUM (Ti)

Metallic element, melting point 1670 °C, density 4540 kg m⁻³. Uses: alloying additions, class of aluminide. Matrix alloy for composites, structural materials for aerospace uses generally where operational temperatures exceed those possible with aluminium. Manufacture of structural shapes with superplastic forming/diffusion bonding technique, [See also: SPF/DB]. Extremely difficult to cast. Sensitive to presence of hydrogen and oxygen

T_m

Melting temperature at which the material changes from the solid state to the molten state, in °C

TML

Total mass loss. [See also: OFFGASSING, OUTGASSING]

TOTAL MASS LOSS (TML)

total mass loss of material outgassed from a specimen that is maintained at a specific constant temperature and operating pressure for a specified time

NOTE: TML is calculated from the mass of the specimen as measured before and after the test and is expressed as a percentage of the initial specimen mass.

[ECSS-Q-ST-70-02]

TOUGHNESS

The energy required to break a material, equal to the area under the stress-strain curve

TOXIC

Substances causing serious, acute or chronic effects, even death, when inhaled, swallowed or absorbed through the skin

[ECSS-Q-70-71]

TOXIC HAZARD INDEX (T)

ratio of the projected concentration of each offgassed product to its SMAC value and summing the ratios for all offgassed products without separation into toxicological categories

NOTE Further details on the calculation of this T-value can also be obtained in NASA-STD-6001.

[ECSS-Q-ST-70-29]

TOXICITY

[See: TOXIC]

TRACEABILITY

The ability to trace the history, application, use and location of an item through the use of recorded identification numbers

TRANSITION TEMPERATURE

The temperature at which the properties of a material change. [See also: GLASS TRANSITION TEMPERATURE]

TRANSVERSE ISOTROPY

Material symmetry that possesses an isotropic plane; e.g. a unidirectional composite

TYPE (INSERT)

The various types of inserts can be grouped by the means that they are embedded into a sandwich panel:

(A) for simultaneous bonding during sandwich production, also known as 'co-cure';

(B) for an existing sandwich using either a thermosetting resin (usual potting process of standard inserts) or for non-standards inserts by an equivalent bonding process, e.g. carbon fibre tube inserts;

(C) for mechanical clamping or screwing into an existing sandwich.

TYPE A (INSERT)

Used for simultaneous bonding during sandwich structure production

TYPE B (INSERT)

Used for an existing sandwich structure; embedded with a thermosetting potting compound (potting of standard inserts), or by an equivalent bonding procedure (non-standards inserts)

TYPE C (INSERT)

Used for mechanical clamping or screwing into an existing sandwich structure

U

UD

Unidirectional

UHM

Ultra-high modulus; a range of carbon fibres

ULTIMATE LOAD

[See: LOADS]

ULTIMATE STRENGTH

the maximum load or stress that a structure or material can withstand without incurring rupture or collapse

NOTE It is implied that the condition of stress represents uniaxial tension, uniaxial compression, or pure shear.

[ECSS-E-ST-32]

ULTIMATE TENSILE STRENGTH (UTS)

Highest stress sustained by a material before catastrophic failure. The ultimate or final stress sustained by a specimen in a tension test; the stress at moment of rupture

NOTE: UTS sometimes denotes ultimate tensile stress.

ULTRA HIGH MODULUS CARBON FIBRES (UHM)

A range of carbon fibres in which the tensile modulus exceeds 395 GPa, typically

ULTRAVIOLET (UV)

Zone of invisible radiation beyond the violet end of the spectrum of visible radiation. Since ultraviolet wavelengths are shorter than the visible, their photons have more energy, enough to initiate some chemical reactions and to degrade most plastics

UNAVIA

Italian standards organisation (new system)

UNDERCURING

An incorrect process in which there is insufficient time or temperature to enable full and proper curing of an adhesive or resin

UNI

Italian standards organisation (old system)

UNIDIRECTIONAL COMPOSITE

A composite having only parallel fibres

UNSYMMETRIC LAMINATE

A laminate without mid-plane symmetry

USA

United States of America; also denoted as US

UTS

Ultimate Tensile Strength or Stress; [See: ULTIMATE TENSILE STRENGTH]

UV

[See: ULTRAVIOLET]

V

VANTICO

Formerly Ciba-Geigy, UK. Manufacturer and supplier of Araldite™ range of epoxy-based adhesives and potting resins

VCM

Volatile Condensable Material

VERIFICATION

The verification is a process oriented to demonstrate that the system design meets the applicable requirements and is capable of sustaining its operational role along the project life cycle, Ref.[Ref-1]

VERY HIGH STRENGTH CARBON FIBRES (VHS)

A range of carbon fibres in which the tensile strength exceeds 3500 MPa, typically

V_f

Volume fraction of reinforcement fibres within a composite material, expressed as a percentage

VHS

Very high strength carbon fibres

VISCOSITY

1 measure of the fluidity of a liquid, in comparison with that of a standard oil, based on the time of outflow through a certain orifice under specified conditions, [ECSS-Q-70-71]

2 The property of resistance to flow exhibited within the body of a material, expressed in terms of relationship between applied shearing stress and resulting rate of strain in shear

VOID

Air or gas trapped in a material during cure, e.g. air or gas bubbles present in the mass of potting after cure

NOTE: Indicates the need for proper venting during the potting process.

VOID CONTENT

Volume percentage of voids, e.g. calculated from the measured density of a cured material and the 'theoretical' density of the starting material

NOTE: Implies that voids are uniformly distributed throughout the body, which is not always the case.

VOLATILE CONTENT

A measure of the mass loss from a sample subjected to prescribed test conditions. The volatile loss is an indication of the solvent content of the material, which can result in high-levels of voids remaining after cure. Occurs due to the vaporisation of the usually low-boiling-point solvent within the resin constituent during cure.

VOLATILES

Materials in a sizing or a resin formulation capable of being driven off as a vapour at room temperature or slightly above

VOLUME FRACTION

Fraction of a constituent material based on its volume; a measure of the quantity of one phase in a composite material, usually the reinforcement fibre content, e.g. denoted as V_f and expressed as a percentage

W

WAISTED

A type of test specimen or coupon where the gauge length is not parallel for the entire length

WARP

1 The yarn running lengthwise in a woven fabric; a group of yarns in long lengths and approximately parallel, put on beams or warp reels for further textile processing, including weaving

2 A change in shape or dimension of a cured laminate from its original moulded shape

WATER ABSORPTION

Ratio of the weight of water absorbed by a material upon immersion to the weight of the dry material. [See also: MOISTURE ABSORPTION]

WATER VAPOUR REGAINED (WVR)

Mass of the water vapour regained by the specimen after the optional reconditioning step.

NOTE: WVR is calculated from the differences in the specimen mass determined after the test for TML and CVCM and again after exposure to atmospheric conditions and 65 % relative humidity at room temperature (22 ± 3) °C.

[ECSS-Q-ST-70-02]

WEAVE

The particular manner in which a fabric is formed by interlacing yarns and usually assigned a style number

WEFT

The transverse threads or fibres in a woven fabric; fibres running perpendicular to the warp.

NOTE: Also called fill, filler, filler yarn, woof

WERKSTOFF-LEISTUNGSBLATT

German standards organisation

WETTING

Flow and adhesion of a liquid to a solid surface, characterised by smooth, even edges and low contact angle

WITNESS SAMPLE

A sample made of identical materials to that used in a composite laminate that undergoes exactly the same processing as the laminate. The objective is to ensure that all the manufacturing processes applied, e.g. lay-up and cure, are correct. Testing and inspection of witness samples provide confidence that the properties of the assembly meet those stipulated in the design; also known as REFERENCE SAMPLE for inserts

WOVEN FABRICS

Fabrics produced by interlacing strands more or less at right angles

WRINKLE

1 A surface imperfection in laminated plastics that has the appearance of a crease in one or more outer sheets of the paper, fabric, or other base which has been pressed in

2 Sandwich panels: deformation of the face skins; a potential failure mode

WROUGHT METAL PRODUCT

Metallic stock material, e.g. in the form of sheet and strip, plate, bar, which is produced by methods involving large amounts of plastic deformation (such as forging, rolling, extrusion) that results in a material with a wrought microstructure, often with some level of anisotropy

Wt%

Weight percent

WVR

Water Vapour Regained

X

XMM

X-ray multi-mirror telescope

Y

YIELD STRENGTH

maximum load or stress that a structure or material can withstand without incurring a specified permanent deformation or yield

NOTE The yield is usually determined by measuring the departure of the actual stress-strain diagram from an extension of the initial straight proportion. The specified value is often taken as a unit strain of 0,002.

[ECSS-E-ST-32]

YIELD STRESS (YS)

Stress at which permanent deformation commences in a material. The limit of reversible elastic behaviour, [See also: PROOF STRESS]

YOUNG'S MODULUS

The ratio of a material's simple tensile stress, within elastic limits, to the resulting strain parallel to the direction of the tensile stress

Z

- no terms or abbreviations -

References called in this clause

[Ref-1]	Alenia Spazio, Italy 'Review and Improvements of ESA AIV Guidelines: TF/DM/9352 (Aug. 1984)' ESA/ESTEC Contract No. AOP/OL/RB/324147. ESA PSS-01-80 Issue 1 - Draft (Sept. 1994)
[Ref-2]	G.F. Dieter 'Mechanical Metallurgy'. McGraw Hill. ISBN 0-07-016891, 1976
[Ref-3]	D.R. Lide, Editor in chief 'Handbook of Chemistry and Physics' 72nd Edition, CRC Press Inc (1992). ISBN-0-8493-0565-9
[Ref-4]	M.H. Weik 'Fibre Optics Standard Dictionary' Chapman & Hall. 3rd Edition (1997). ISBN 0-412-12241-3
	ECSS-P-001, ECSS – Glossary of terms
	ECSS-E-ST-32, Space engineering - Structural general requirements
	ECSS-E-ST-32-01, Space engineering - Fracture control
	ECSS-E-ST-32-08, Space engineering - Materials
	ECSS-Q-ST-70-02, Space product assurance – Thermal vacuum outgassing test for the screening of space materials;
	ECSS-Q-ST-70-22, Space product assurance – Control of limited shelf-life materials
	ECSS-Q-ST-70-29, Space product assurance – Determination of offgassing products from materials and assembled articles to be used in a manned space vehicle crew compartment
	ECSS-Q-70-71, Space product assurance – Data for the selection of space materials and processes

4

Insert system

4.1 Insert systems and components

4.1.1 Inserts

An insert is part of a detachable fixation device, which enables the interconnection of honeycomb-sandwich structures; connection between such structures and other structural parts, e.g. frames, profiles, brackets; mounting of equipment, e.g. boxes, feed lines, cable ducts.

The system consists of a removable and a fixed structural element. The removable part is either a screw or other threaded element adapted to a nut-like part, the insert. This is connected to the honeycomb-structure by using a potting compound; normally a two-part epoxy resin system, [See also: 7.1 "Potting compound"].

Figure 4-1 shows the components of a standard type of insert system, [See also: 5.2].

NOTE Non-standard types of inserts are described in A.3 and carbon fibre-reinforced plastic tube inserts in F.6.

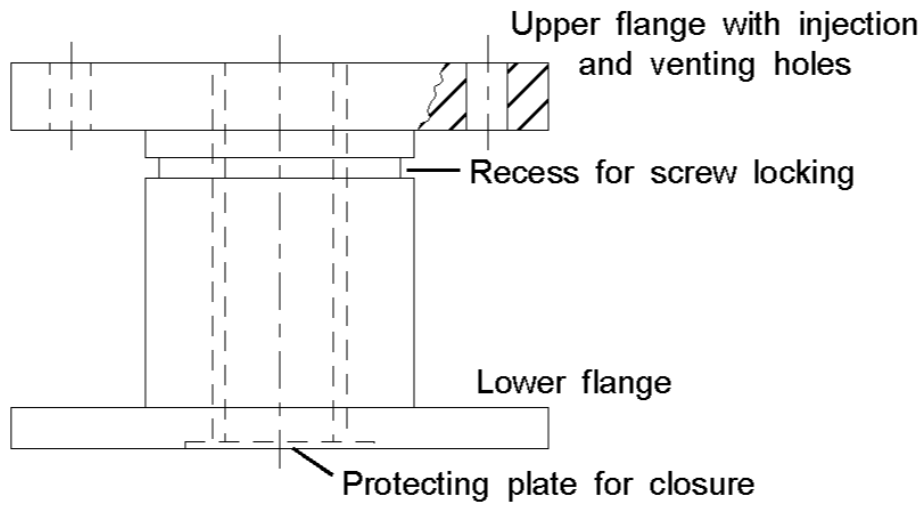

A – Typical standard-type insert

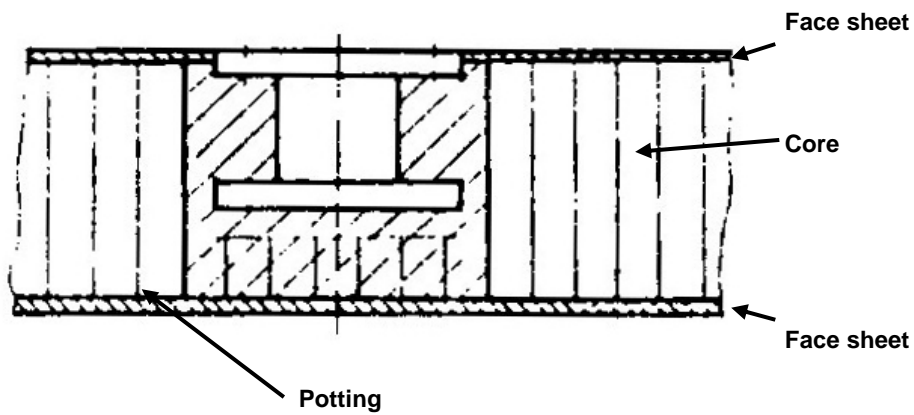

Honeycomb panel

[See also: 8.1] “Structural sandwich concept”

B – Typical standard-type insert embedded in honeycomb panel

Figure 4-1: Insert system: Components

4.1.2 Insert system components

The insert system consists of three main components:

- Insert;
- Sandwich structure;
- Potting material.

The items that form an insert system are given in Table 4-1.

Table 4-1: Insert system: General definition

INSERT SYSTEM	Insert	Male threaded element	[See: Table 5-1]
		Female threaded element (either fixed or replaceable)	
	Joining method	Mechanical clamping or screwing	Not advised
		Bonding with resin: simultaneously during sandwich production, or integration into an existing sandwich (by potting or an equivalent method).	[See: Table 5-1]
	Sandwich	Face sheet	[See also: 6.1]
		Bonding component	
Core			

NOTE The terms used to describe the different types of inserts vary across the industry, e.g.:

- Partially potted, also known as: blind, 'borne', single-sided.
- Fully potted, also known as: through-the-thickness, double-sided, transverse.

[See also: Figure 8-7]

4.1.3 Loading modes

The basic types of insert loading are summarised in Figure 4-2, [See also: Clause 10]

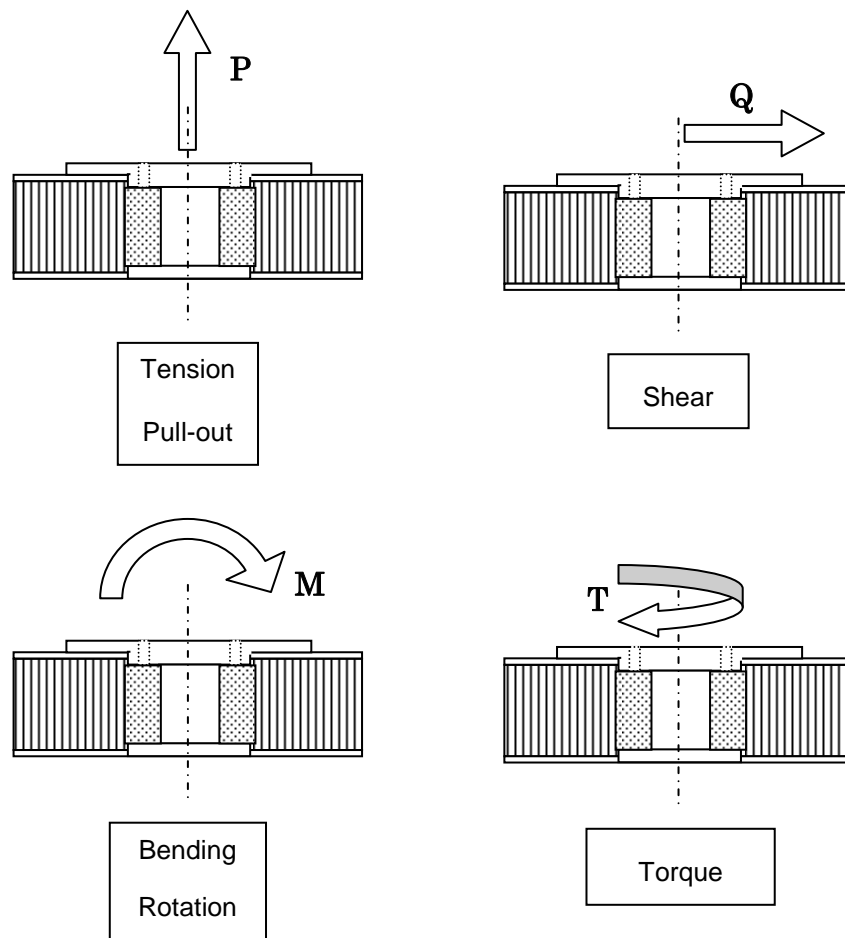

NOTE Insert with flanges illustrated, but loading modes apply to all types of inserts, [See: 5.1].

[See Figure 8-8 for the notation for forces acting on an insert]

Figure 4-2: Insert system: Summary of loading modes

5 Insert

5.1 General

Inserts are usually described by their:

- Type, e.g. grouped by the means in which they are embedded into a sandwich structure, [See: 5.2].
- Size, [See: 5.3].
- Material, [See: 5.4].
- Surface protection, [See: 5.5].

5.2 Types

5.2.1 General

There are three types of insert which are distinguished by the method of integration into the honeycomb sandwich structure; as shown in Table 5-1. These are:

- Group A for simultaneous bonding during sandwich production;
- Group B for an existing sandwich using a thermosetting resin, e.g.:
 - usual potting process of standard inserts.
 - an equivalent bonding procedure for non-standards inserts.
- Group C for mechanical clamping or screwing into an existing sandwich.

5.2.2 Group A

These inserts are used only in rather thin sandwich structures, i.e. low core height, and can be applied only in cases where no particular locking demands exist. Moreover, it is rather difficult to position the insert exactly at the point at which it is needed for connection purposes. For this reason, the insert has a large diameter to enable the drilling of a bore hole and thread cutting to provide a margin of between 3 mm and 6 mm for misalignment.

Table 5-1: Types of inserts

Type	Shape	Diameter (mm)	Material	Potting Considerations	Torque Locking	Thread Locking	Floating Nut Exchange Capability	Standards	Comments
Type A: Bonding during sandwich manufacture									
1		17 to 30	Al	Full bonded with core filler	None or square shape	e.g. Locktite	No	-	The bore hole is drilled after sandwich bonding. Only for small core height.
Type B: Potting (or equivalent non-standard procedure)									
2		11 to 22	Al (St) (Ti)	Partially or fully potted	Planes or ruffles	Deformation of tread	No	NAS 1832 NSA 5135 PA 3825 ENN 3GG/386	Al insert can be used with St or Ti screws. Most common type.
3		11 to 22	Al (St) (Ti)	Partially or fully potted	Planes or ruffles	Deformation of tread	No	-	Rarely used
4		11 to 14	Al	Fully potted only	Planes or ruffles	e.g. Locktite	No	NAS 1832 TAN 16489 PAN 3827 NSA 5071	Available with and without thread.
5		6 to 14	St Ti	Partially or fully potted	Planes or ruffles	e.g. Locktite	No	ERNO No. R 000/095.000	Rarely used.
6		3 to 6	St Ti	Partially or fully potted	Planes or ruffles	e.g. Locktite	No	-	Only for very low loads. Rarely used.
7		19 to 70	Al	Partially or fully potted	Planes or ruffles	e.g. Locktite	No	-	For high loads
8		19 to 25	Al: Insert Ti: Nut	Partially or fully potted	Planes or ruffles	Deformation of thread	Yes	NAS 1835 PAN 3829 ENN 379 NSA 5072	Extended and heavy type for applying floating nuts and exchanging capacity.
9		7 to 20	CFRP / Al	Carbon fibre tube bonded into core	N/A	e.g. Locktite, helicoils.	No	No	Carbon fibre tube inserts, [See also: A.3 and F.6]
10		-	-	-	-	-	-	-	[See also 10.3] [Ref. [5-2]]
Type C: Mechanically clamped or screwed									
11		14 to 22	Al (St) (Ti)	-	Adhesive bonding	Deformation of thread	No	TAN 16485	Low pull-out strength, if no connection with core.
-		14 to 22	Al (St) (Ti)	-	Adhesive bonding	-	No	-	-

Key: St: steel; Ti: titanium; CFRP: carbon fibre-reinforced plastic

5.2.3 Group B

Inserts potted by means of curing epoxy resin are the most important group. The main part of this handbook is concerned exclusively with inserts of this type.

Non-standard alternatives, in which the normal potting is replaced by an equivalent bonding procedure, are described in Annex A and Annex F, [See: A.3 and F.6].

A normal potted insert, incorporated in honeycomb-sandwich structures by potting, has the basic shape shown in Figure 5-1.

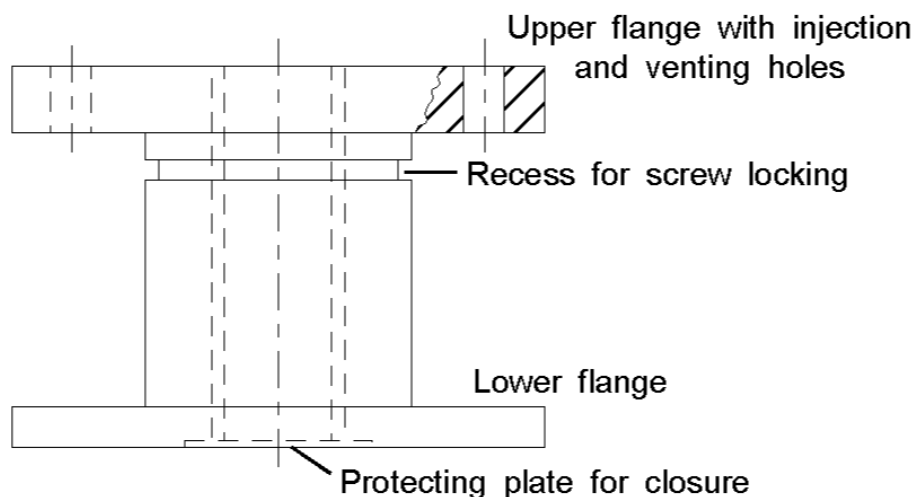

Figure 5-1: Typical insert

A hollow cylindrical body with flanged ends is the standard configuration. Both the discs and flanges provide a form-locking connection with the resin and prevent applied loads from being transferred only by adhesion shear forces between resin and insert.

The upper flange is pierced by two holes, one for the injection of the potting resin and one for venting purposes.

The cylindrical section and the lower flange have a rifled surface, or the lower flange has flats on opposite sides. Both provisions increase the shear-load capability when the insert is subjected to torsion.

A thin circular sheet in the lower flange protects the thread from resin contamination during potting. A recess in the upper part of the cylindrical body permits thread deformation by compression. This is to ensure self-locking of the mated screw.

[See also: 10.3 for flanged inserts]

5.2.4 Group C

The mechanically fastened inserts have significant disadvantages:

- No direct connection with the sandwich core which causes low load-carrying capability;
- An individual adapted size for each core height;
- Torque can be transferred by adhesive bonding only.

5.2.5 Potting methods

The four different methods of potting inserts in general use are described in Table 5-2.

NOTE The potting dimensions should be justified if other techniques are used.

Table 5-2: Potting methods

Potting method	Device	Potting level ⁽¹⁾	Expected filling	Comments
Casting	Resin funnel apparatus	full	very good	Feasible but impracticable method. A resin reservoir is needed above each insert to complete filling due to resin shrinkage.
		partial	bad	No longer in use. Sandwich plate has to be turned over before curing.
Injection	Compressed air cartridges (Semco cartridges)	full partial	good ⁽²⁾ good	Very economical method when a large number of inserts are fitted.
	Manual injection (by small medical squirter)	full partial	good ⁽²⁾ good	Usual for a small number of inserts, e.g. repair. Injection methods enable handling of sandwich plate immediately after potting.
Foaming	no	full	good	Usual when inserts are potted during sandwich manufacture process.
Paste application	spatula	full partial	bad	Not advisable for standard potting, i.e. filling of honeycomb cells. Preferred method for CFRP tube inserts, [See also: A.3; F.6].
NOTE (1)	See also: Figure 8-7 for schematic of 'full' and 'partial' potting.			
NOTE (2)	100 % filling is not possible because a small amount of air always remains trapped at the top of core cells.			

5.2.6 Injection

The injection method is the most frequently used because of its advantages when a large number of inserts are fitted.

NOTE Except for data in Annexes, the data given in this handbook for standard inserts are based upon test results from specimens prepared by the injection method in accordance with the stated manufacturing procedure, [See: 23.3].

5.3 Sizes

5.3.1 General

There are a wide variety of sizes, shapes and dimensions available because inserts were developed separately in various countries by different companies.

The products can be grouped as:

- Commercially available, which are standard specified items, [See also: A.2];
- Non-standard, which are designed and manufactured “in-house” for a particular project application, [See also: A.3]:
 - based on ‘conventional’ insert designs, where dimensions or materials used are different, [See also: F.1 for case studies];
 - novel insert designs, e.g. carbon fibre tube inserts, [See also: A.3; F.6 for an example of their use within the Rosetta Lander project].

5.3.2 Standards

Many inserts have been qualified to meet company standards, project-related standards or, after approval by national airworthiness authorities, national standards.

A list of some standards is given in Table 5-3.

Table 5-3: List of insert standards

National Aerospace Standard	NAS	1832
		1833
		1835
		1836
		1837
Deutsches Institut für Normung	DIN	65187
		65188
		65189
		65190
		65191
		65192
		65193
Transall-Norm	TAN	16487
		16488
		16489
		16490
Panavia-Standard	PAN	3825
		3826
		3827
		3828
		3829
Deutsche Airbus-Norm	DAN	214
Normalisation Sud Aviation	NSA	5345
		5074
ERNO-Norm	ENN	366
		377
		379
		386
		398

5.3.3 Strength

The most important parameters related to strength are:

- Insert overall diameter d_i ;
- Insert overall height h_i

Consequently, within this handbook, the insert load-carrying capabilities are based on these two parameters.

5.3.4 Standardised diameters

The standardised diameters are given in Figure 5-2, which shows that certain diameters are preferred. It indicates that:

- Diameters that follow a geometrical progression of the type $(a.q^n)$ where the constants are $a = 8,96$ and $q = 1,25$;
- Advisable standard set of diameters, which best fits the presently standardised diameters.

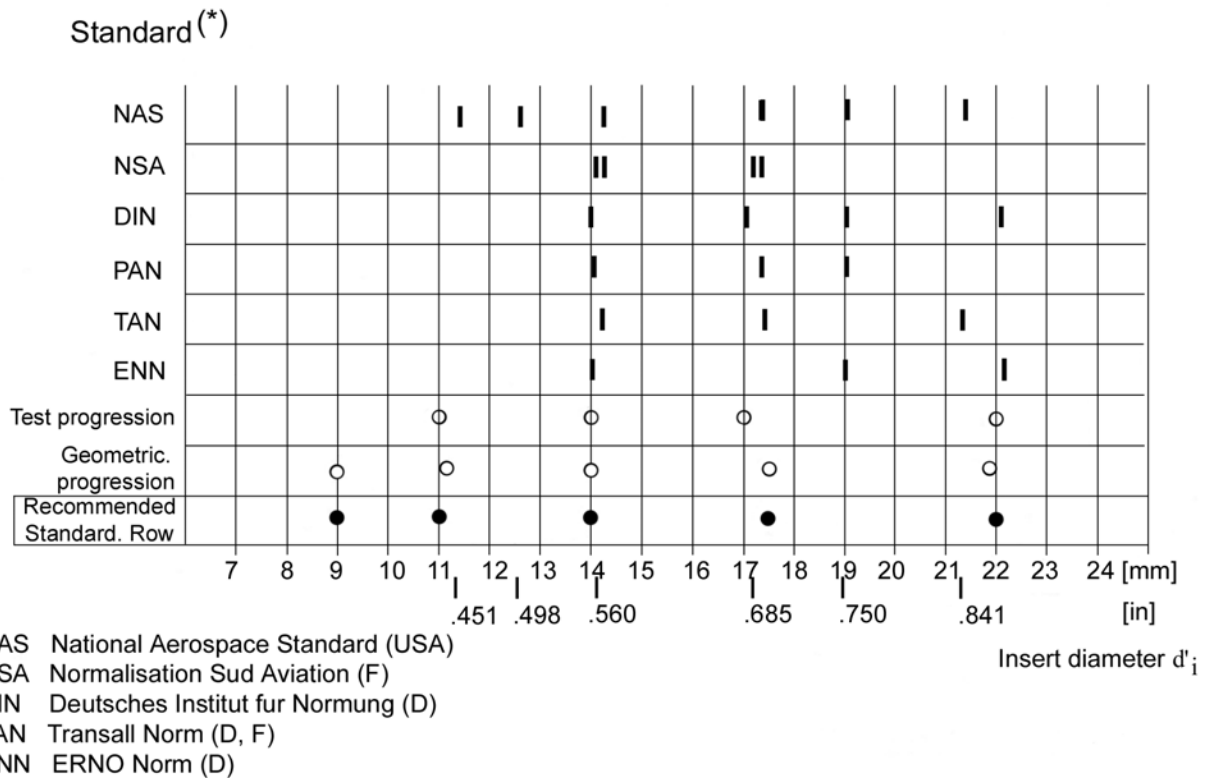

NOTE "Test progr." denotes diameters investigated in [Ref. [5-1]].

Key: (*) See also Table 5-1

Figure 5-2: Standardised insert diameter

5.3.5 Standardised heights

The standardised insert heights in Figure 5-3 show considerable scatter and no preferred heights can be identified.

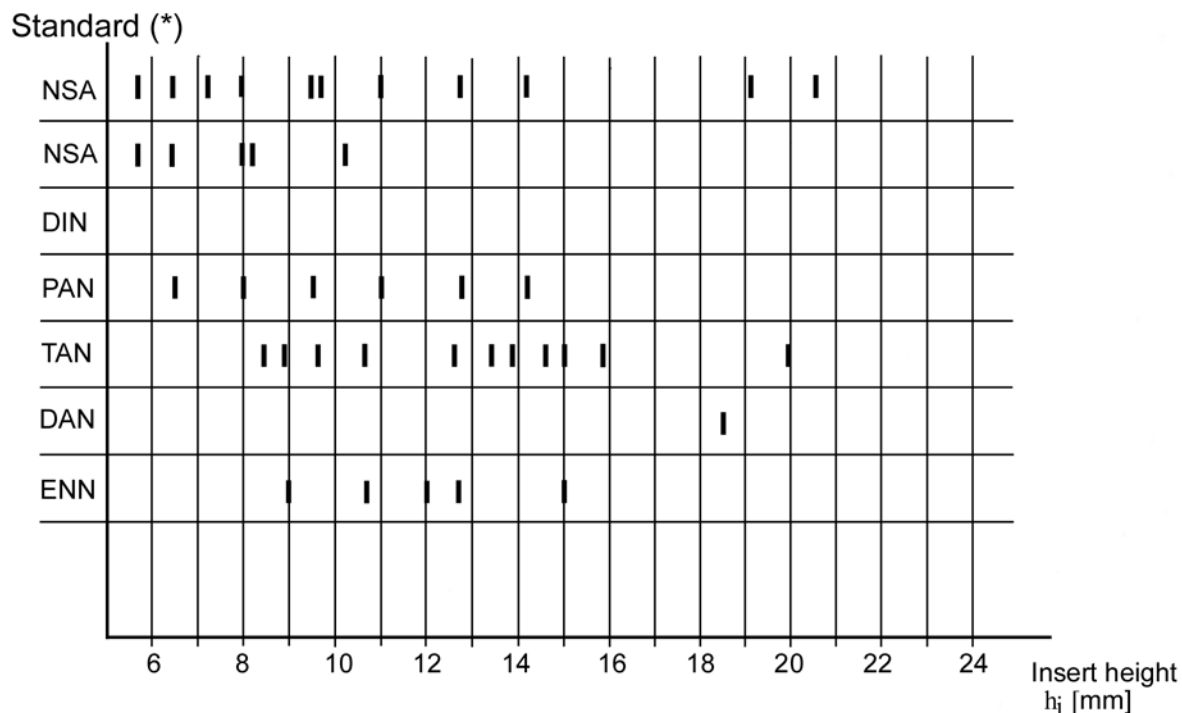

Key: (*) See also Table 5-1

Figure 5-3: Standardised insert height

When standardised insert heights are plotted as a function of standardised insert diameters, as shown in Figure 5-4, the dashed lines denote examples of linear dependencies.

An advised set of insert heights was derived on the basis of the straight line that connects the crossing of preferred diameters with heights in whole millimetres.

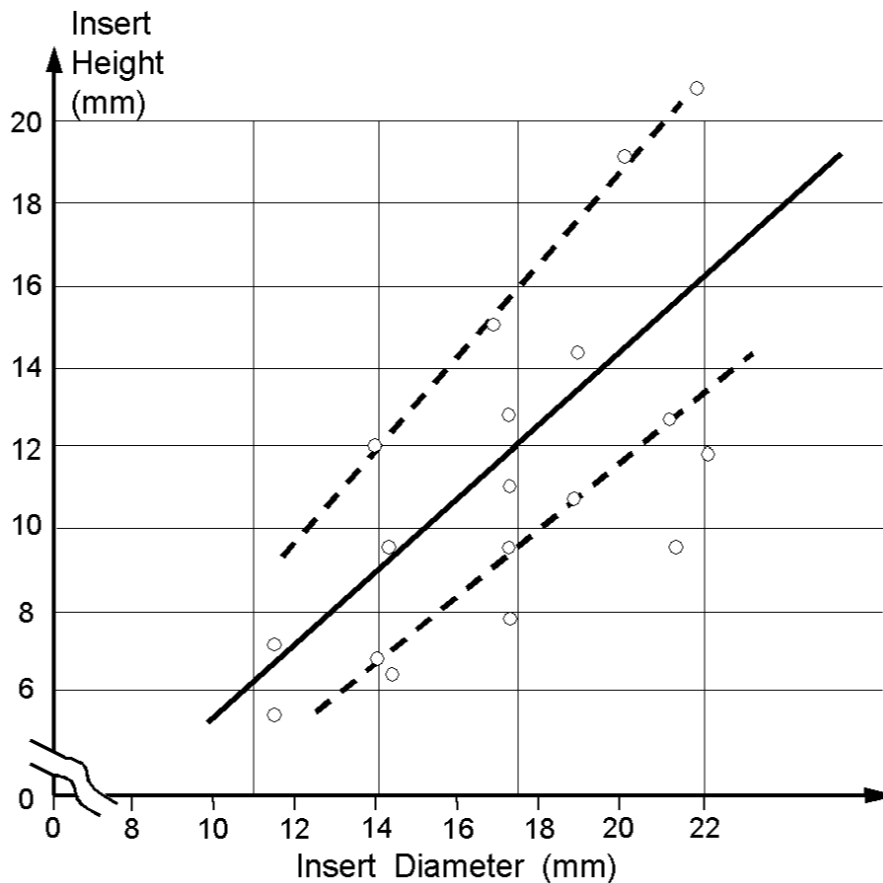

Figure 5-4 Preferred set of insert heights

5.4 Materials

5.4.1 General

The majority of standard commercially-available inserts are made from certain grades of metals or combinations thereof, these being:

- **Aluminium Alloys**
- **Titanium Alloys**
- **Steels, both carbon steel and stainless alloys.**

[See also: ECSS-Q-70-71]

Non-standard inserts can be made from the same or different grades of metals or, more recently, from carbon fibre-reinforced plastics, [See also: A.3].

A summary of inserts used in space applications is given in Annex A for:

- commercial products, [See: Table A-1]
- non-standard items, [See: Table A-2].

[See also: Annex F for case studies]

5.4.2 Aluminium alloys

Usually inserts are made of aluminium alloy AA 2024 (DIN AlCuMg2), solution heat treated and naturally or artificially aged, thus having the condition T85.

Some comparable material designations are given in Table 5-4, Ref. [5-1].

NOTE Chemical compositions of 'equivalent alloys are not always identical.

[See also: Table 5-5 for surface protection]

Table 5-4: Inserts: Aluminium alloy 'equivalents'

Country	Equivalent Grade ⁽¹⁾	Standards Organisation
Europe	AW-2024	CEN
Germany	3.1354-T851	Werkstoff-Leistungsblatt
	AlCuMg2	DIN
U.K.	3L65	BS../Common Files/Glossary-B.pdf
	2024	
France	A-U4G1	AIR 9050/C
	2024	AFNOR
Italy	PAC 4,5 GM	UNAVIA 811-02
	9002/4 (3583)	UNI (old system)
U.S.A.	QQ-A-225/6-T8511	Federal specification
	2024-T8511	MIL-HDBK-5
	2024	ASTM
Japan	2024	JIS
Russia	1160	CIS

Key: (1) Chemical compositions of 'equivalent' alloys are not always identical.

5.4.3 Titanium alloys

Titanium alloy TiAl6V4 (solution treated and aged) is used for applications where improved strength or special locking properties are needed, [See also: Table 5-5 for surface protection].

5.4.4 Steels

5.4.4.1 Carbon steels

Steel is sometimes used, e.g. carbon steel AISI 1137 (as referred in Fed. Std. 66) in heat-treated and water-quenched conditions, inserts made from carbon steels are always cadmium plated, [See also: Table 5-5 for surface protection].

NOTE According to ECSS-Q-70-71, the use of cadmium-plating in spacecraft structures is not allowed, due to sublimation problems that can arise in thermal vacuum.

5.4.4.2 Stainless steels

Carbon steels are replaced by stainless steels of the austenitic type, e.g. AISI 303 or 1.4305 to DIN 17007.

[See also: Table 5-5 for surface protection]

5.4.5 Material selection

The materials that the inserts are made from, the materials and processes used to embed them and the sandwich panels themselves conform to the ECSS standards, [See: ECSS-E-ST-32-08; ECSS-Q-70-71].

If the insert is potted with an epoxy resin, there is no advantage in using a material that has a higher temperature resistance than aluminium, i.e. the resin fails at a lower temperature than the onset of damage to the insert.

It is also unreasonable to select an insert material stronger than aluminium, because the strength of the system is limited by the strength of the epoxy.

Inserts with changeable floating nuts make it possible to use a higher-strength material for the nut within the aluminium housing.

The thread within the bore can be closed on the bottom side of the lower flange by a thin, flat shim or cup made of aluminium alloy AlMgSiCu, i.e. AA 6061 in a soft annealed temper.

[See also: Annex F for case studies]

5.5 Surface protection

5.5.1 General

All inserts need protection to prevent corrosion. Some typical insert materials and their surface protection are given in Table 5-5.

A summary of inserts used in space applications is given in Annex A for both commercial products, [See: Table A-1], and non-standard items, [See: Table A-2].

[See also: Annex F for case studies]

5.5.2 Aluminium alloy

The housings made from aluminium alloy 2024 (AlCuMg₂) are treated by a specified anodising process, e.g. LN 9368, Code No. 2100 or MIL-A-8625 C.

Galvanic treatment in a sulphuric-acid bath results in a 10µm to 15µm thick aluminium oxide layer, which is hard and electrically nonconductive. This preserves the insert from corrosive attack and gives a suitable bonding surface. For insert systems with floating and removable nuts, the housing, plug and nut are treated in the same manner.

Covers closing the bore hole are chromated in accordance with MIL-C-5541, Class IA. When a cup is applied as a closure, the inner and outer surfaces are chromated.

NOTE According to ECSS-Q-70-71, the use of cadmium-plating in spacecraft structures is not allowed, due to sublimation problems that can arise in thermal vacuum.

Table 5-5: Typical insert materials and surface protection

	Material designation	Some applicable specifications	Applied surface protection
Aluminium alloys	2024 (AlCuMg ₂) heat-treated and aged (naturally or artificially): Condition T85	3.1354 - T8511 Werkstoff- Leistungsblatt 2024 - T8511 QQ-A-225/6 811-02 UNAVIA A-U4GI AIR 9050	Anodised, e.g. LN 9368 Code 2102 MIL-A-8625C.
	AlMgSiCu soft annealed temper	AA 606 3.3214 LN 811-05 UNAVIA	Chromated
Titanium alloy	TiAl6V4 solution treated and aged	3.7164.7 Werkstoff-Leistungsblatt Ti-6Al-4V MIL-HDBK-5 COMP.T-A6V AIR 9183	Normally not necessary. Anodised for special cases.
Steels	Carbon steel	AISI 1137	Cadmium plated (1)
	Stainless steel	AISI 303 ASTM A 582 1.4305 DIN 303 BS	Passivated LN 9368

5.5.2.1 Stainless steel

Inserts of stainless steel are passivated to a specified standard, e.g. LN 9368, Code No. 1200.

5.5.2.2 Titanium alloys

Titanium parts, if any, are used without any treatment because they automatically develop a protective oxide layer after machining.

In order to increase protection against corrosion, an additional coating can be created using a specified anodising treatment, e.g. LN 9368, Code No. 2500.

5.6 References

5.6.1 General

- [5-1] R. Hussey & J. Wilson - RJ Technical Consultants
'Light Alloys Directory and Databook',
Chapman & Hall, ISBN 0 412 80410 7 (1998)
- [5-2] N. Laval - Sonaca SA, Belgium
'Inserts with flanges'
Working Group contribution (2004)
- [5-3] J. Block - DLR, Germany
Working Group contribution (2004)
- [5-4] MIL-HDBK-5
Metallic Materials and Elements for Aerospace Vehicle Structures

5.6.2 ECSS standards

[See: ECSS website: www.ecss.nl]

ECSS-E-ST-32-08, Space engineering - Materials

ECSS-Q-ST-70, Space product assurance - Materials, mechanical parts and processes

ECSS-Q-70-71, Space product assurance - Data for the selection of space materials and processes

6

Sandwich panels

6.1 Sandwich properties

A sandwich consists of, [See also: 8.1]:

- Face Sheets (top and bottom);
- Core;
- Adhesive film (for bonding).

6.1.1 Insert load-bearing capability

The contribution of the sandwich parts to the load-bearing capability of an insert is shown in Table 6-1.

Table 6-1: Effect of sandwich components on insert load-bearing capability

Load type	Contribution of sandwich component to insert load-bearing capability		
	Core	Face sheet	Core/face bond
Tension	High	Medium	Very low ⁽¹⁾
Compression	High	Medium	Low
Shear	Low	High	Very low ⁽¹⁾
Bending	High	Medium	Low
Torsion	High	Low	Low

NOTE (1) Contribution in case of non-metallic face sheets can need reconsideration.

6.1.2 Sandwich dimensions

The principal dimensions of a sandwich are shown in Figure 6-1

Where:

f_1, f_2 = thickness of facing sheets, f if $f_1 = f_2$

c = core height

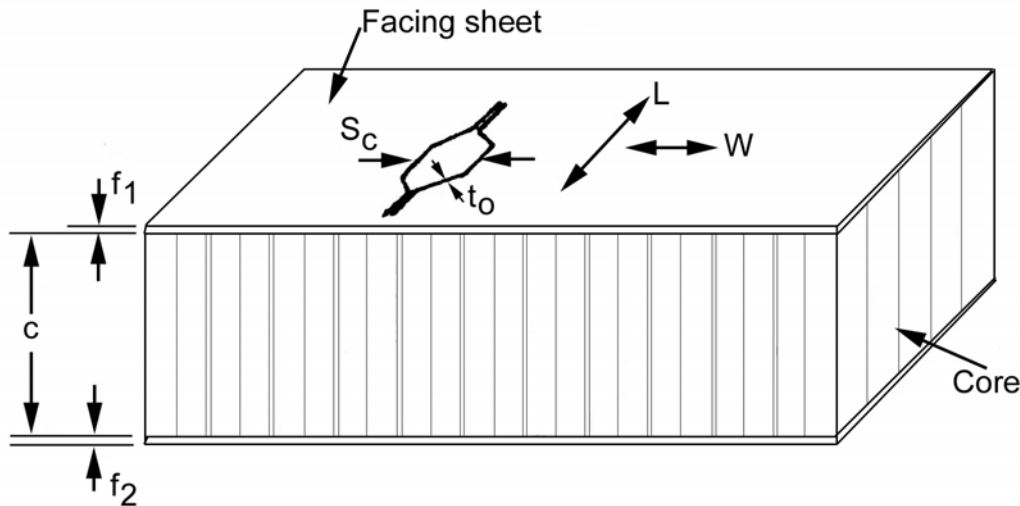

Figure 6-1: Sandwich and core: designation

6.2 Face sheet properties

The characteristics of face sheets are dictated by the properties of the materials used, e.g. metal or composite.

For composite face sheets, the laminate construction determines the directional properties; as shown in Figure 6-2.

6.2.1 Tensile and compressive loading

6.2.1.1 Strength

The strength values of the face sheets do not usually influence the tensile or compressive load-carrying capability of an insert.

6.2.1.2 Stiffness

The capability of an insert under tensile and compressive loading is influenced by the bending stiffness, B , of the face sheets.

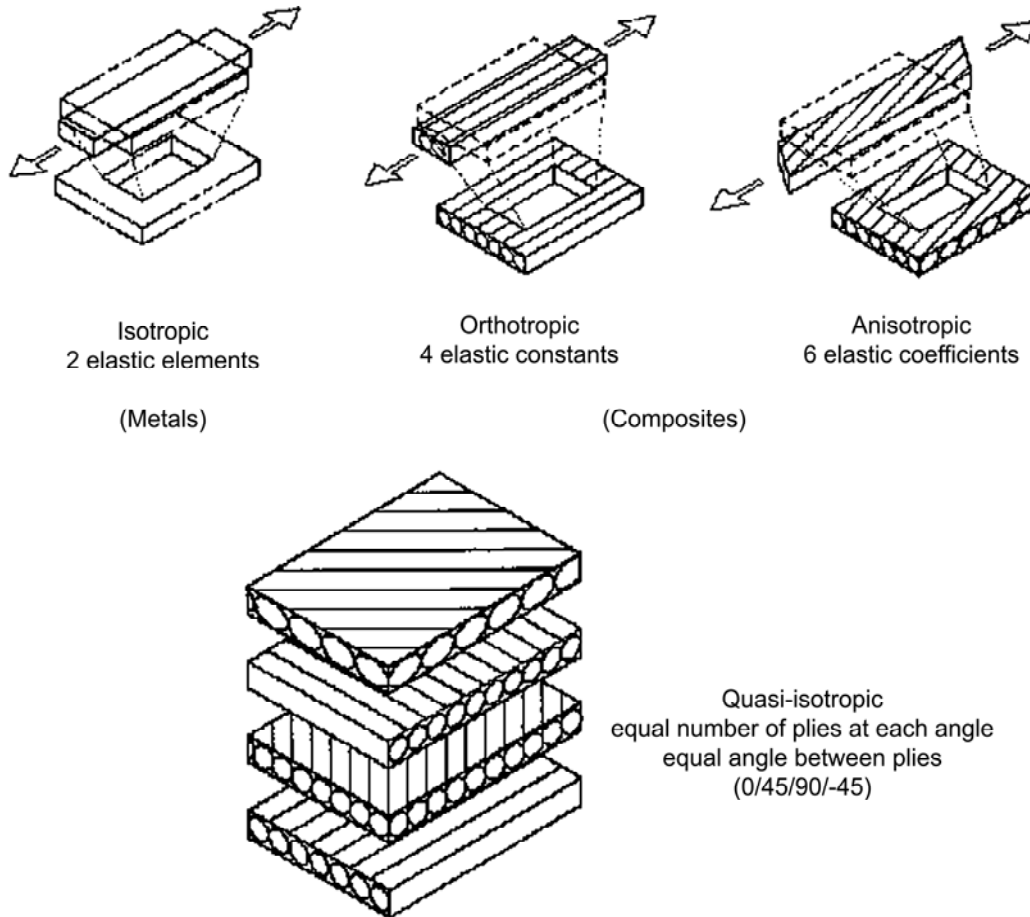

Figure 6-2: Face sheet properties: Isotropic, anisotropic and quasi-isotropic characteristics

6.2.1.3 Isotropic face sheets

The higher the bending stiffness, B , of the face sheets compared with the shear stiffness of core, the higher the load contribution of the face sheets.

For isotropic face sheets:

$$B = \frac{E_f f^3}{12(1-\nu_f^2)} \quad [6.2-1]$$

Thus the relevant properties of the face sheets are:

- f face sheet thickness
- E_f Young's modulus of face sheets
- ν_f Poisson's ratio of face sheets
- σ_{fy} yield strength of face sheets

For an analytical determination of the insert load-capability, these values should be applied in the equations developed in Annex C.

6.2.1.4 Anisotropic face sheets

The coupling and flexural stiffness is used in the calculation of the load contribution for anisotropic face sheets.

A close approximation can be made regarding the slight influence of the face sheet (about 10% to 20%) at typical face sheet to core combinations.

E_f and ν^2 in Eqn. [6.2-1] are replaced by $(\sqrt{E_x \times E_y})$ and $(\nu_x \times \nu_y)$ respectively, where these values are the results of the in-plane laminate theory.

The conversion, shown in Eqn. [6.2-1], enables the insert capability diagrams to be used.

These diagrams were generated for sandwich structures with different aluminium face sheets, but also applied to sandwich structures with anisotropic face sheets.

$$f_{Al} = f_{an} \sqrt[4]{\frac{\sqrt{E_x \times E_y} (1 - \nu_{Al}^2)}{E_{Al} (1 - \nu_x \times \nu_y)}} \quad [6.2-2]$$

where:

- f_{Al} face sheet thickness aluminium
- f_{an} face sheet thickness anisotropic material
- E_x E-modulus x-direction
- E_y E-modulus y-direction
- ν_{Al} Poisson's ratio aluminium
- ν_x Poisson's ratio x-direction anisotropic
- ν_y Poisson's ratio y-direction anisotropic

6.2.2 Shear loading

6.2.2.1 Isotropic face sheets

For in-plane shear loads on isotropic face sheets, the yield strength of the upper face sheet is relevant to the insert load capability, [See: 6.6].

The failure mode is a compressive buckling of the isotropic face sheet, [See also: 6.6 for core tensile strength].

6.2.2.2 Anisotropic face sheets

An in-plane shear loaded anisotropic face sheet, e.g. CFRP, can fail by different modes, as shown in Figure 6-3.

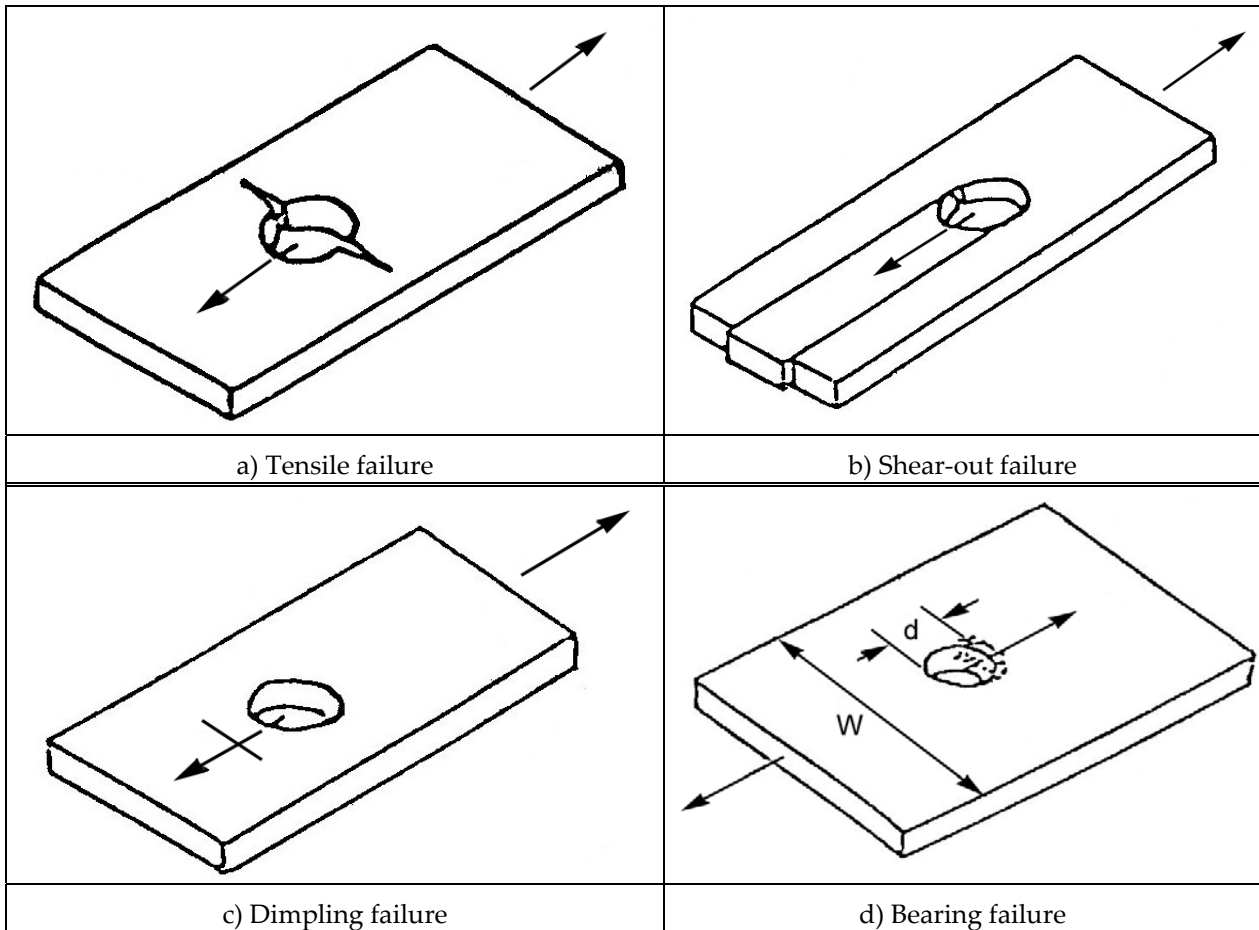

Figure 6-3: Possible failures modes: Anisotropic face sheets under shear-loading

Table 6-2 shows the shear-load capabilities of tested CFRP face sheets, manufactured from two materials often used in spacecraft.

Where the material or stacking sequences of the composite face sheets deviate, the shear-load capabilities can only be a gross indication for the design. In this case, a detailed investigation of the pin-loaded shear capability of the selected composite has to be performed.

Table 6-2: Failure mode and shear-load capability of tested CFRP face sheets

	Fibre orientation (°) outer / inner	$E^{\theta\theta}$ basis test	$\sigma^{\theta\theta}_{max.}$ basis test	$P_{max.}$ test (N)	Failure modes	Tension Compression	$d_{ins}/w^{(2)}$	
		$E^{\theta\theta}$ theory ⁽¹⁾	$\sigma^{\theta\theta}$ theory ⁽¹⁾					
		(N/mm ²)	(N/mm ²)					
Laminate	914 C - T300	0/90	75.047	812 790	2653 2760	dimpling dimpling	T C	0.25
		90/0	75.047	812 790	2253 2160	dimpling dimpling	T C	
		45/-45	13.086	151 228	2660 2381	bearing dimpling	T C	
		45/0/-45	57.714	645 602	4653 4163	bearing bearing	T C	
		22.5/-22.5/-67.5	37.610	319 380	4531 4315	bearing bearing	T C	
		60/0/ 60	52.631	568 589	3870 3813	bearing bearing	T C	
		30/-30/-90	27.344	216 293	3605 3858	bearing bearing	T C	
	914 C - HM	0/90	95.542	545 410	1825 2128	tensile dimpling	T C	0.25
		45/-45	12.518	80 118	1931 2069	tensile	T C	
	914 C - T300	45/-45	13.086	151 228	2234 1849	bearing/ tensile bearing/ tensile	T C	0.16

NOTE (1) Properties shown with grey background were determined by laminate theory.

NOTE (2) Insert diameter / Specimen width.

6.2.3 Other loads

The face sheet properties are unlikely to have a significant effect under other loading conditions.

6.3 Core properties

6.3.1 Types of cores

This handbook is primarily concerned with hexagonal honeycomb cores, although the analytical determination of the insert load capability, as described in Annex C, is also valid for other types of core, i.e. tubular, corrugated and foam cores.

6.3.2 Hexagonal core

The relevant dimensions of the hexagonal core are:

- Cell size, S_c
- Foil thickness, t_o

[See also: Figure 6-1]

6.3.2.1 Core anisotropy

Two principal directions characterise any hexagonal core:

- L -direction, coinciding with the direction of the doubled foils;
- W -direction, perpendicular to the L -direction.

As a result of the core anisotropy, the shear strength and the shear modulus in the L -direction are approximately twice that of the W -direction.

6.3.2.2 Effect on insert strength

The anisotropic behaviour has only a small influence on the insert strength capability, owing to:

- Deviations in the nominal core density ($\pm 10\%$) caused by:
 - deviation in the nominal foil thickness;
 - deviation in the geometrically-exact hexagonal cell forms, caused by the expansion process.
- pre-buckling properties of the cell walls caused by the hole piercing process on perforated cores.

6.3.2.3 Mechanical properties

The mechanical properties of cores vary very widely, as shown in Figure 6-4. Consequently, a distinction is made between:

- Guaranteed core strength related to minimum insert load-carrying capabilities combined with minimum potting size;
- Typical core strength related to typical insert load-carrying capabilities combined with typical potting size.

[See also: 6.6]

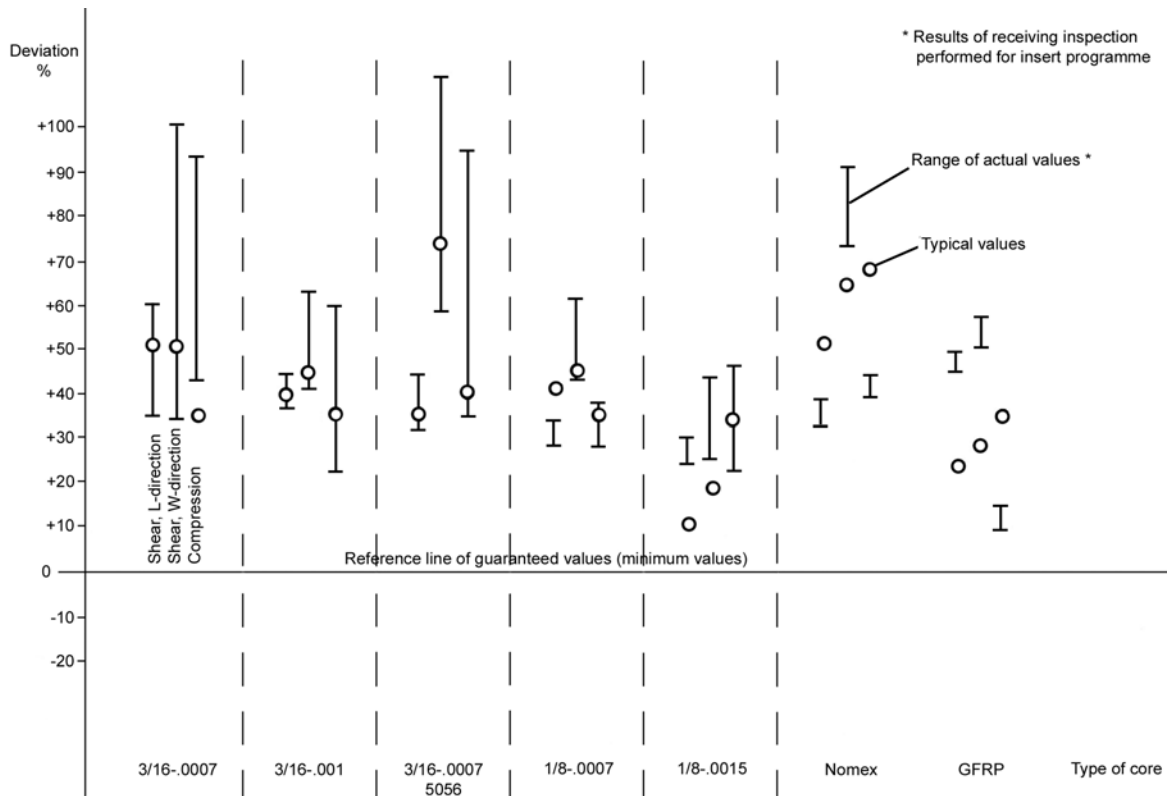

Figure 6-4: Core strength: Deviation (%) of actual strength from guaranteed values

The core properties are more important for inserts subjected to normally-acting tensile or compression loads. These properties are the:

- Shear modulus, [See: 6.4];
- Shear strength, [See: 6.5];
- Tensile strength, perpendicular to the sandwich plane, [See: 6.6];
- Compressive strength, perpendicular to the sandwich plane, [See: 6.7].

Table 6-3 gives the mechanical properties of common types of aluminium cores. Mechanical properties for some common types of non-metallic cores are shown in Table 6-4.



Table 6-3: Mechanical properties of common aluminium alloy hexagonal-type cores

Designation (1)		Properties (4)		Density	Cell size	Foil thickness	Shear modulus			Shear strength			Perpendicular strength (3)		
		supplier	test				γ_c	S_C	t_o	G_L	G_W	G_C	τ_{Lcrit}	τ_{Wcrit}	τ_{Ccrit}
				kg/m ³	mm	mm	N/mm ²	N/mm ²	N/mm ²	N/mm ²	N/mm ²	N/mm ²	N/mm ²	N/mm ²	N/mm ²
Aluminium alloy	5052	3/16-5052-.0007p	guar. typ.		28.8 32.0	4.8	0.02	186	98	32.6	0.55 0.83	0.32 0.48	0.44 0.65	2.77 3.08	0.69 0.93
				min. av.										0.57 0.73	
		3/16-5052-.001p	guar. typ.		44.7 49.7	4.8	0.03	310	152	50.6	1.07 1.45	0.62 0.90	0.84 1.22	4.31 4.79	1.48 2.00
				min. av.									1.08 1.28		1.69 2.00
		1/8-5052-.0007p	guar. typ.		44.7 49.7	3.2	0.02	310	152	50.6	1.07 1.45	0.62 0.90	0.84 1.22	4.31 4.79	1.48 2.00
				min. av.									1.08 1.27		1.69 2.00
	1/8-5052-.001p	guar. typ.		64.0 71.1	3.2	0.03	483	214	71.3	1.97 2.34	1.16 1.52	1.58 2.06	6.16 6.85	2.79 3.75	
			min. av.									1.88 2.07		3.17 3.75	
	5056	3/16-5056-.0007p	guar. typ.		28.8 32.0	4.8	0.02	186	90.0	30.0	0.72 0.97	0.34 0.69	0.46 0.80	3.36 3.77	0.82 1.10
				min. av.									0.68 0.87		0.95 1.10
			guar. typ.		44.7 49.7	4.8	0.03	310	138	46.0	1.38 1.76	0.76 1.07	1.03 1.45	5.26 5.85	1.79 2.48
		3/16-5056-.001p		min. av.									1.30 1.46		2.13 2.48
guar. typ.				44.7 49.7	3.2	0.02	310	138	46.0	1.38 1.76	0.76 1.07	1.03 1.45	5.26 5.85	1.79 2.48	
1/8-5056-.0007p			min. av.									1.30 1.46		2.13 2.48	
		guar. typ.		64.0 71.1	3.2	0.03	483	193	64.3	2.41 2.93	1.41 1.76	1.92 2.39	7.60 8.45	3.44 4.62	
1/8-5056-.001p			min. av.									2.22 2.39		4.03 4.62	

NOTE (1) Designation: cell size - core alloy - foil thickness

NOTE (2) Basis of insert capability plots, [See: Annex B] ; P=90% values; Not-tested values from suppliers' datasheets

NOTE (3) T - Tensile; C - Compressive

NOTE (4) guar. - guaranteed; typ. - typical; min. - minimum; av. - average



Table 6-4: Mechanical properties of common non-metallic hexagonal-type cores

Designation (1)		Properties (4)		Density	Cell size	Foil thickness (5)	Shear modulus			Shear strength			Perpendicular strength (3)		
		supplier	test				γ_c	S_c	t_o	G_L	G_W	G_C	τ_{Lcrit}	τ_{Wcrit}	τ_{Ccrit}
				kg/m ³	mm	mm	N/mm ²	N/mm ²	N/mm ²	N/mm ²	N/mm ²	N/mm ²	N/mm ²	N/mm ²	N/mm ²
Non-metallic cores	Nomex (6)	HRH 10 - 1/8 - 1.8	guar. typ.		25.9 28.8	3.2		25.5	13.8	4.6	0.45 0.62	0.25 0.34	0.34 0.48	2.71 3.00	0.59 0.90
				min. av.											
		HRH 10 - 1/8 - 3.0	guar. typ.		43.2 48.0	3.2		48.3	24.1	8.0	1.12 1.24	0.59 0.66	0.63 0.90	4.59 5.10	1.86 2.28
				min. av.											
		HRH 10 - 1/8 - 4.0	guar. typ.		57.6 64.0	3.2		63.5	32.4	10.8	1.55 1.69	0.77 0.97	1.05 1.32	6.63 7.36	3.24 3.86
				min. av.											
	HRH 10 - 3/16 - 2.0	guar. typ.		28.8 32.0	4.8		29.0	15.2	5.1	0.50 0.76	0.28 0.38	0.38 0.52	3.08 3.42	0.72 1.03	
			min. av.												
	HRH 10 - 3/16 - 3.0	guar. typ.		43.2 48.0	4.8		48.3	24.1	8.0	0.93 1.24	0.46 0.66	0.63 0.90	4.59 5.10	1.86 2.28	
			min. av.												
	HRH 10 - 3/16 - 4.0	guar. typ.		57.6 64.0	4.8		63.5	32.4	10.8	1.55 1.69	0.77 0.97	1.05 1.32	6.63 7.36	3.24 3.86	
			min. av.												
GFRP	HRP - 3/16 - 4.0	guar. typ.		28.8 32.0	4.8		79.0	34.0	11.3	1.45 1.79	0.76 0.96	1.03 1.31	7.11 7.90	3.31 4.14	
			min. av.												
	HRP - 3/16 - 5.5	guar. typ.		75.6 64.0	4.8		134	59	19.7	2.55 2.93	1.31 1.52	1.78 2.08	10.44 11.60	5.17 6.48	
			min. av.												

NOTE (1) Designation: material - cell size – density

NOTE (2) Basis of insert capability plots, [See: Annex B]

NOTE (3) T - Tensile; C - Compressive

NOTE (4) guar. - guaranteed; typ. - typical; min. - minimum; av. - average

NOTE (5) Not available

NOTE (6) Nylon fibre/phenol resin

6.4 Core shear modulus

The shear modulus of the core influences the way in which the load transmitted through the insert is distributed between face sheets and core.

The greater the core stiffness is, the lower the load contribution of the face sheets.

6.4.1 Data sources

Values of core shear modulus are not specified in standards, such as MIL-C-7438 F. Values are quoted only in datasheets prepared by core suppliers, taking into account both core directions *W* and *L*. These figures are too high in comparison with insert test results and for this reason they cannot be applied for the analytical determination of the static strength of the insert.

From measurements, the shear modulus varies with the loading and tends to decrease as a result of non-linearity, i.e. shear buckling of single foils occurs at half the expected value.

Consequently, an effective core shear modulus, G_c , that reflects the real situation is:

$$G_c = G_W / 3 \quad [6.4-1]$$

Where:

G_W shear modulus in *W*-direction.

[See: Table 6-3 for G_c values for common types of aluminium cores; Table 6-4 for G_c values for common types of non-metallic cores].

6.5 Core shear strength

When inserts are subjected to tensile or compressive loads, the load-carrying capability is determined by the ability of the core to take the axially-induced load transmitted from the insert via the potting compound. This can only be performed by shear forces.

When loaded in tension or compression, the insert system fails by a shear rupture of the core foils surrounding the insert.

The circular strength is applied because both foil directions participate in the transmission of the shear force.

Since the number of single foils in the *L*-direction is 72% greater than in the *W*-direction, the effective core shear strength, which is relevant for the insert load-capability is given by:

$$\tau_{c\,crit} = 1.36 \tau_{w\,crit} \quad [6.5-1]$$

This applies for 'guaranteed' as well as for 'typical' shear-strength values.

6.5.1 Data sources

Usually the guaranteed minimum shear strength values, $\tau_{crit.min}$ should be used. The values listed in Table 6-3 and Table 6-4 are taken from MIL-C-7438 F and suppliers' datasheets.

The typical values in Table 6-3 and Table 6-4 are from datasheets previously published by the core suppliers.

A typical value is the expected average value stated by the supplier.

6.6 Core tensile strength

The core underneath partially potted inserts loaded in tension can fail by tensile rupture, [See also: 10.1].

6.6.1 Data sources

The tensile strength of the core perpendicular to the sandwich plane is not specified in the standards or in the suppliers' data sheets.

6.6.2 Aluminium core

The tensile strength of the aluminium core is therefore defined by:

$$\sigma_{0\,crit\,t} = \sigma_{0\,crit\,t} \frac{\gamma_c}{\gamma_0} \quad [6.6-1]$$

Where:

$\sigma_{0\,crit\,t}$	tensile strength of core material: 270 N/mm ² for AA 5052 H38 (from MIL-HDBK-5), or 330 N/mm ² for AA 5056 H38.
γ_c	core density, e.g. 32 kg/m ³ for 3/16-5052-.0007 core.
γ_0	density of core material, e.g. 2800 kg/m ³ for aluminium.

The typical values $\sigma_{c\,crit\,t\,typ}$ listed in Table 6-3 are based on the typical core density $\gamma_{c\,typ}$.

The minimum values $\sigma_{c\,crit\,t\,min}$ take into account the maximum allowable scatter of core density values of $\pm 10\%$.

$$\sigma_{c\,crit\,t\,min} = 0.9 \sigma_{0\,crit\,t} \frac{\gamma_c}{\gamma_0} \quad [6.6-2]$$

6.6.3 Non-metallic cores

Where typical tensile strengths of non-metallic core materials were not available, $\sigma_{c\,crit\,t\,typ}$ was assumed to be equal to $\sigma_{c\,crit\,c\,typ}$.

The minimum values $\sigma_{c\,crit\,t\,min}$ was calculated by:

$$\sigma_{c\,crit\,t\,min} = 0.9 \sigma_{0\,crit\,c\,typ} \quad [6.6-3]$$

Table 6-4 includes tensile strengths of Nomex® and GFRP determined by this method.

NOTE These tensile strength values are considered to be very conservative.

6.7 Core compressive strength

The core underneath partially potted inserts loaded in compression can fail by compressive rupture, [See: 7.5].

The compressive strength $\sigma_{c\ crit\ c}$ of the core perpendicular to the sandwich plane is given as:

$\sigma_{c\ crit\ c\ min}$ minimum compression strength:

- metallic cores: MIL-C-7438 F
- non-metallic cores: suppliers' data.

$\sigma_{c\ crit\ c\ typ}$ typical compression strength of core, taken from core suppliers' data.

6.8 Core to face sheet bond

Failure of the bond between the core and face sheet is not experienced in insert tests.

The load transferred from the insert to the face sheets, which are usually thin in spacecraft applications, is so low that it is easily transmitted by the bond.

NOTE The foot of a bracket connection needs a minimum diameter at least equivalent to the potting diameter $2b_p$.

[See: 10.4] References

- [6-1] MIL-HDBK-5 Metallic Materials and Elements for Aerospace Vehicle Structures
- [6-2] MIL-C-7438 F Core Material, Aluminum, For Sandwich Construction

7

Embedding of inserts

7.1 Potting compounds

7.1.1 Commercial products

Commercially available insert potting materials are usually 2-part epoxy resin systems, [See: ECSS-Q-70-71]. Their inherent characteristics are usually modified by additions of microballoons, e.g. for mass-reduction; viscosity control; to aid processing.

Table 7-1 summarises some potting compounds used in space applications, Ref. [[7-1], [7-3], [7-4]].

NOTE The component parts of potting compounds (resin, hardener, accelerators) are limited shelf-life materials so their usable life, storage and working conditions are controlled, e.g. workshop environment and pot-life, [See: ECSS-Q-ST-70-22]

Other types of adhesives are sometimes used during the integration of inserts into sandwich panels, including:

- Film adhesives for bonding insert flanges onto sandwich panel external surfaces, e.g. BSL 312 UL, [See: F.5]; Loctite-Hysol 9321, [See: F.7];
- Foaming adhesives for co-cured sandwich panels with inserts, e.g. Cytec/Cyanamid: FM 410-1 (150 °C); FM 37 (120 °C), Ref. [7-1].

Table 7-1: Example: Insert potting compounds for space applications

Supplier:	Cure temp.	Density	Tensile strength	Compressive strength	Shear strength	Tensile modulus	Temp. use	Source[]	
Product code	°C	γ_R kg/m ³	$\sigma_{R\ crit}$ N/mm ²	σ_R N/mm ²	$\tau_{R\ crit}$ N/mm ²	E_R N/mm ²	°C		
Emerson & Cuming: Lekutherm X227		0.6 to 0.7	14	36	10	2300	<100	MBB-ERNO [3] [See: 25.1; 25.3]	
Altropol: Neukadur EP 270 + 3M Scotchlite H20/1000 micro- ballons	RT/24h + 60/2h	0.64	14	36	10	2300	<100	CASA [1]; Patria [4] [7]; Astrium UK [7] with T3 hardener	
Vantico: Araldite 2011 (AW 106/HV953U)								[2]; Sonaca [7]; Case study: F.2; F.3	
Vantico: Araldite 2004 (Araldite AV138M/ HV 998)	RT							Daimler-Benz Aero. [1]; Sonaca [7] [See: ECSS-Q-70-71]	
3M – Scotchweld EC2216								[2]; Sonaca [7]; Case study: F.3; F.10	
Emerson & Cuming: Stycast 1090/9	RT			73 (average)				CASA [1]; Patria [4]; Kongsberg [6]; Astrium UK [7]; See also: IATP E.2	
	180							Alcatel Espace [1]	
Emerson & Cuming: Stycast 1090 SI:	RT							CASA [1]; Alenia- Spazio [1]; Astrium UK [7]	
Shur-lok: SLE 3010 LVC	RT							CASA [1]; [2]; Contraves [1, 2, 5]; Case study:F.4; F.5; F.7; F.9; F.10; F.11	
Scheufler: L160 / H163 + glass micro-ballons + Aerosil	RT/18h 90/12h	0.58	17	43	13 to 15	2000	<90	DLR [7]; [8]; Case study F.6; A.3	
Cytec/Cyanamid: FM 410-1	150	(foam adhesive)							Contraves [1]; Sonaca [7] for co-cured inserts
Others:	[See: Supplier's websites for product information]							[1]	
Altropol: Neukadur EPX227/ Durosehl3 + 3M microballons	RT	-	-	-	-	-	-	DASA-RI [1]	
Emerson & Cuming (Possehl): Lekutherm + microballons		-	-	-	-	-	-	Alenia-Spazio [1]	
Silmid: AY103; AV121; HY951; BJO 0930	RT/18h 60/1h	-	-	-	-	-	-	Westlands [1]	
3M	RT	-	-	-	-	-	-	BAe Airbus [1]	
Loctite-Hysol	RT	-	-	-	-	-	-	BAe Airbus [1]	
Vantico	RT	-	-	-	-	-	-	BAe Airbus [1]	
Source					[6] 'IATP 2 - Insert Allowable Test Program No.2' Kongsberg Gruppen AS, Test Report No. 02TR68040906 (Oct. 1997)				
[1] Insert Technology Industry Survey (1995)					[7] ECSS insert design handbook working group survey (2004)				
[2] 'Matra Marconi Space Contribution to ESA Insert Design Handbook'; MMS Ref. NT/102/BG/355013.96 (Dec. 1996)					[8] 'Study on Carbon Fibre Tube Inserts' J. Block, R. Schütze, T. Brander, K. Marjoniemi, L. Syvänen, M. Lambert: DLR Braunschweig/ Helsinki University. Technology/Patria; ESTEC Contract No. 16822/02/NL/PA, (2004)				
[3] From ESA 'Insert Design Handbook' (1987)									
[4] Private communication (Feb. 2002)									
[5] Private communication (Feb. 2002)									

7.1.2 Modification of properties

Most resin systems are adapted for potting of inserts by the addition of other materials that modify the properties. Such modifications can affect the overall mechanical and thermal performance but also the processing characteristics.

The viscosity is usually monitored to ensure compatibility with the process method used to apply the potting compound, e.g. injection, [See also: 23.3; 25.3].

7.1.2.1 Lekutherm X227

The potting material, applied in the manufacturing procedure [See: 23.3] is a liquid two-component epoxy resin of reduced weight and simultaneously improved viscosity. This is achieved by the addition of glass microballoons.

A characteristic property of this resin is that it can only be applied by injection with an air-pressurised gun. Provided that the correct viscosity is maintained, it does not flow after injection.

[See Table 7-1]: for basic RT properties of Lekutherm X227; 25.3 for mixing and cure conditions]

NOTE Neukadur EP 270, which is widely used for insert potting, is a more recent variant of the Lekutherm X227 epoxy system. Some variation within properties can therefore be expected between the two resin systems.

7.2 Potting and equivalent dimensions

7.2.1 Insert load capability

Unlike the insert dimensions, the potting dimensions have a decisive influence on the load capability of the insert.

The relevant dimensions, shown in Figure 7-1, are the:

- potting radius, [See also: 7.2.2 Increasing insert tensile capability]:
 - effective potting radius, b_p , [See: 7.3].
 - real potting radius, b_R , [See: 7.4].
- potting height, h_p , [See: 7.5].

NOTE Equivalent' potting dimensions relate to carbon-fibre tube inserts, [See: 7.2.1.2 Type B insert].

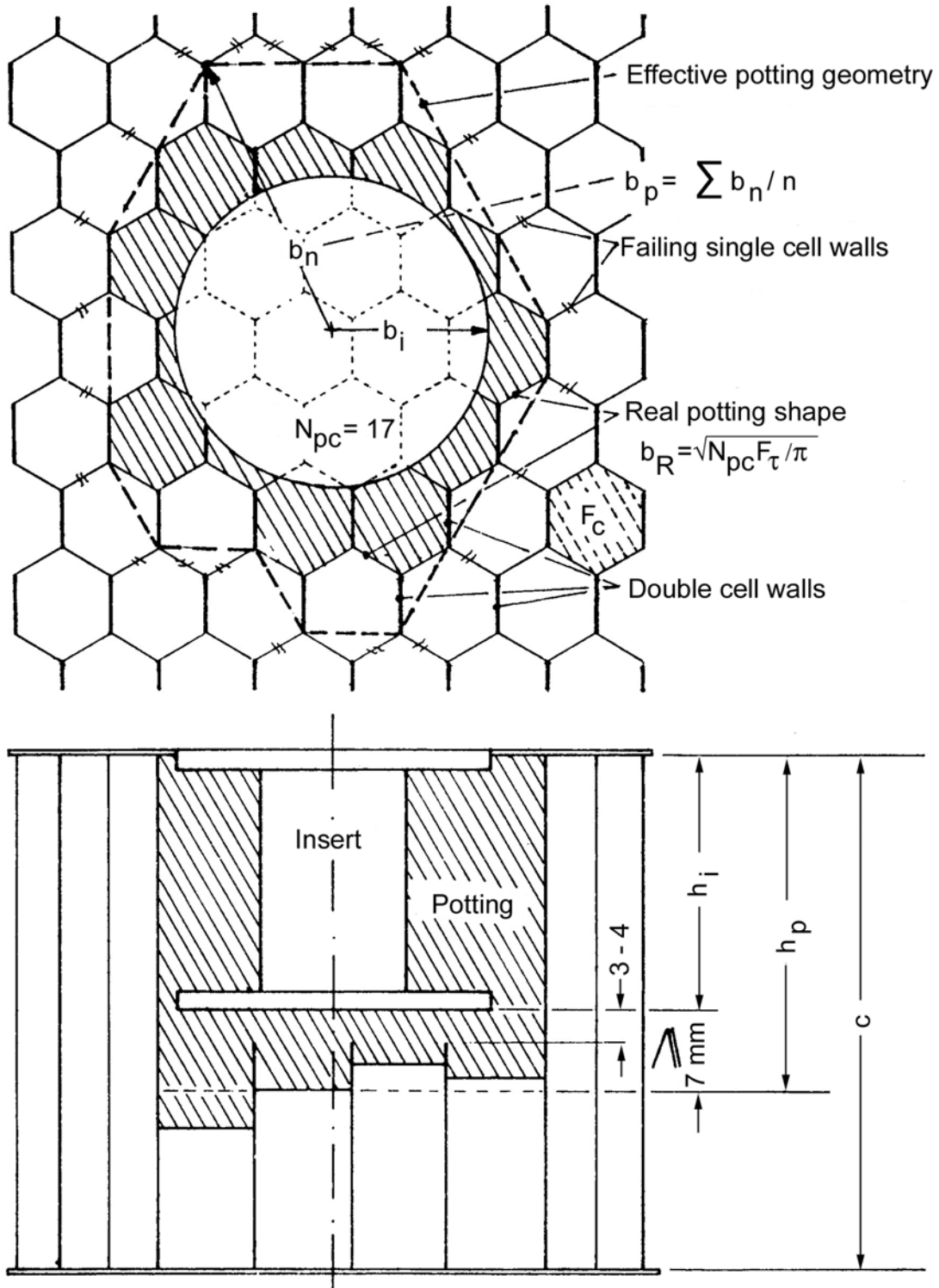

Figure 7-1: Potting geometry

7.2.1.1 Type A insert

The potting dimensions of the, seldom used, insert implemented during sandwich manufacturing (Type A) should be established individually, [See: Table 5-1].

7.2.1.2 Type B insert

These dimensions are valid for the Type B insert, [See: Table 5-1].

For carbon-fibre tube inserts, [See: Table 5-1, Type B 9], the potting dimensions, as depicted in Figure 7-1, are replaced by equivalent parameters, [See: A.3 and F.6 for details].

7.2.2 Increasing insert tensile capability

7.2.2.1 General

The capability of an insert can be improved by increasing the potting radius, [Ref. [7-3]]. In practice, this can be achieved by opening each cell within the bore hole.

7.2.2.2 Example

Table 7-2 shows the effect of increasing the potting radius for a partially potted insert, [Ref. [7-3]].

- Insert (single):
 - Shur-lok SL601 M6-15.9S;
 - diameter 17.4 mm, height 15 mm.
- Sandwich panel:
 - face sheets: aluminium AZ5GU-T6 (7075-T6), 1 mm thick.
 - core: nida 4-40 AG5, height $c = 40$ mm.
- Potting: SLE 3010; RT cure.

Table 7-2: Example: Effect of increased potting radius on insert tensile capability

Bore hole	Average value (N)	Minimum value (N)	No. of samples
Normal	7895	6240	4
Improved ⁽¹⁾	8850	7180	5

NOTE (1) Additional cells opened compared with 'Normal' bore hole, [Ref. [7-3]].

7.3 Effective potting radius, or equivalent dimension

The effective potting radius b_p is an analytical dimension describing the radial influence zone of the potting, [See: Figure 7-1].

b_p is relevant for the load participation of the core around and underneath the potting, [See also: 12.1; Annex C].

- b_p takes into account that the double cell walls adjacent to the potting, which are much stiffer and stronger than the single cell walls and which generally do not fail, can be considered as an integral part of the potting.
- b_p is defined as the average distance of the nearest single cell walls surrounding the potting from the centre of the insert.

$$b_p = \frac{1}{n} \sum b_n \quad [7.3-1]$$

The effective potting radius, b_p depends on:

- Insert radius, b_i ;
- Size of core cell, S_c ;
- Location of insert centre within the hexagonal cell.

NOTE 1 The equations provided here assume classical insert potting.

NOTE 2 For carbon-fibre tube inserts and other non-standard insert designs, the equations remain valid when an equivalent definition for b_p is used, [See: A.3 and F.6 for details].

7.3.1 Minimum value

For each combination of insert radius and cell size, the effective potting radius b_p attains a minimum value for a certain position of the insert centre within the hexagonal cell. This minimum is given by the formulas, [Ref. [7-2]]:

- Perforated core:

$$b_{p\min} = 0.93192 b_i + 0.874 S_c - 0.66151 \quad [7.3-2]$$

- Non-perforated core:

$$b_{p\min} = 0.9 b_i + 0.7 S_c \quad [7.3-3]$$

7.3.2 Average value

The average or typical value of b_p is given by:

- Perforated core:

$$b_{p\text{typ}} = 1.002064 b_i + 0.940375 S_c - 0.7113 \quad [7.3-4]$$

- Non-perforated core:

$$b_{p\text{typ}} = b_i + 0.8 S_c \quad [7.3-5]$$

7.3.3 Relationship of minimum and average values

Non-perforated core Figure 7-2 shows the effective potting radius for non-perforated core (Eqn. [7.3-3]) and (Eqn. [7.3-5]) plotted as a function of the insert diameter.

[See also: Table 12-2 for perforated, aluminium core; Table 12-3 for non-perforated, non-metallic core]

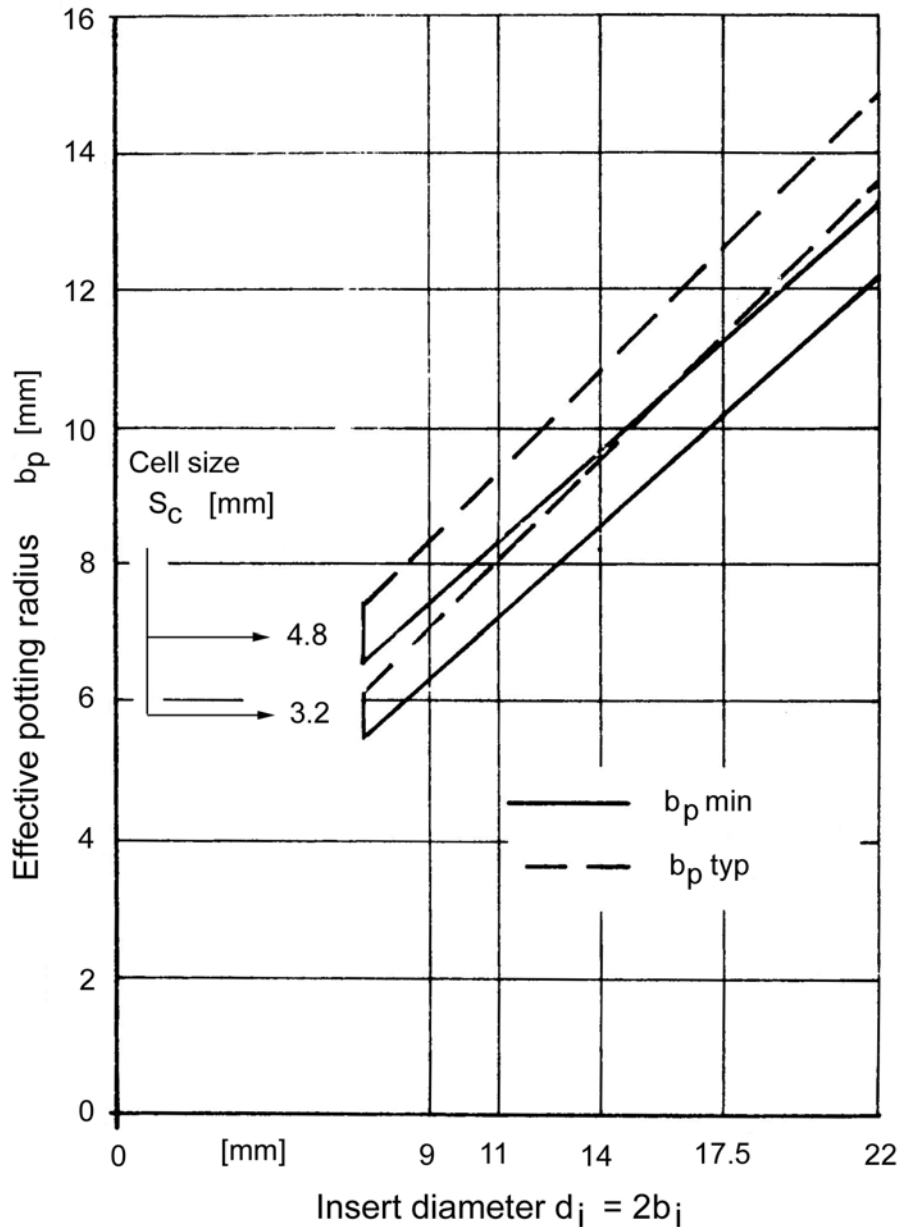

Figure 7-2: Effective potting radius as a function of insert diameter

NOTE Improved data using (Eqn. [7.3-4]) and (Eqn. [7.3-5])
 [See also: Table 12-2 for perforated aluminium core, Table 12-3 for non-perforated, non-metallic core].

7.4 Real potting radius, or equivalent dimension

The real potting radius b_R is the radius of the circle the area of which is identical to the real cross-sectional area F_R of the potting:

$$b_R = \sqrt{\frac{F_R}{\pi}} = \sqrt{\frac{N_{PC} F_C}{\pi}} \quad [7.4-1]$$

Where:

N_{PC} number of core cells filled in with potting resin

F_C cross-sectional area of one core cell:

$$F_C = 0.95 \times 0.75 \times S_C^2 \cos \alpha \quad [7.4-2]$$

Where:

0.95 reduction for imperfect hexagonal shape of cell;

S_C nominal size of core cell;

α 30° for hexagonal honeycomb;

F_C 8.4 mm² if $S_C = 3.2$ mm;

F_C 19.0 mm² if $S_C = 4.8$ mm.

Like the effective potting radius b_p [See: 7.3], the real potting radius b_R depends on b_i , S_C and the position of the insert centre with respect to the hexagonal cell. b_R is relevant to the tensile failure of the potting.

7.4.1 Minimum value

The minimum real potting radius b_R can be described by, [Ref. [7-2]]:

$$b_R = b_i + 0.35 S_C \quad [7.4-3]$$

7.4.2 Average value

The average or typical value of b_R is given by:

$$b_{R\text{typ}} = b_i + 0.5 S_C \quad [7.4-4]$$

NOTE 1 The equations provided here assume normal insert potting.

NOTE 2 For carbon-fibre tube inserts and other non-standard insert designs, the equations remain valid when an equivalent definition for the minimum real potting radius, b_R , is used, (See: A.3 and F.6 for details).

7.4.3 Relationship between minimum and average values

Figure 7-3 shows minimum and average values of real potting radius b_R for the two most frequently used cell sizes of 3.2 mm (1/8") and 4.8 mm (3/16").

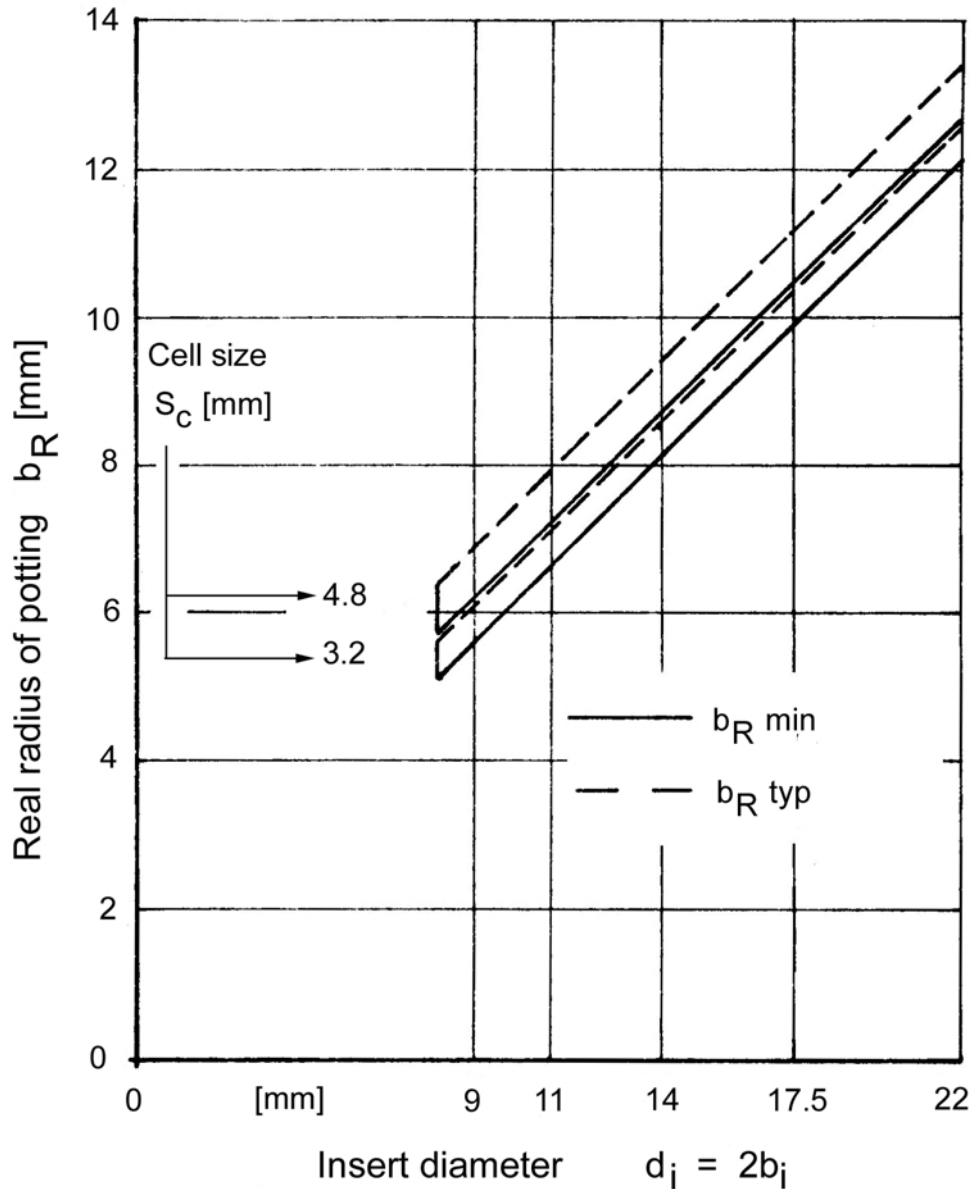

Figure 7-3: Real potting radius as a function of insert diameter

7.5 Potting height

The potting height h_p is the average depth down to which the core cells concerned are filled with potting resin, [See: Figure 7-4]

7.5.1 Full potting

The maximum possible potting height is identical to the core height, c . This is fundamentally the case if the insert height is in the range between core height c , and $(c - 7 \text{ mm})$:

$$h_p = c \quad \text{for} \quad c \geq h_i \geq c - 7 \text{ mm} \quad [7.5-1]$$

This case is called 'full potting'.

7.5.2 Partial potting

For greater core height ($c > h_i + 7$ mm), the potting height is generally smaller than the core height. This case is called 'partial potting'.

7.5.3 Minimum value

The minimum potting height necessary for partial potting depends on the insert height, h_i :

$$h_{p \min} = h_i + 7 \text{ mm} \quad [7.5-2]$$

The value of 7 mm results from the:

- Bore hole should be 3 mm to 4 mm deeper than the insert height;
- Core, underneath the insert, has at least to be connected by the potting resin over a depth of 3 mm.

$h_{p \min}$, which is independent of core height, should be used for the derivation of permitted design minima.

7.5.4 Average value

The average potting height, used for the derivation of typical permissible design values, depends on the core height c and the size of the core cells S_c :

$$h_{p \text{ typ}} = h_{p \min} + A \tanh\left(\frac{c - h_{p \min}}{h_{p \min}}\right) \quad [7.5-3]$$

With: $A = 2.5$ mm for $S_c = 3.2$ mm, and: $A = 5.0$ mm for $S_c = 4.8$ mm.

Where: $\tanh()$ is the hyperbolic tangent.

7.5.5 Relationship of minimum and average values

The relationship between potting height (h_p , $h_{p \min}$, $h_{p \text{ typ}}$) and core height c for the frequently used insert height, i.e. $h_i = 9$ mm, is shown in Figure 7-4.

7.5.5.1 Full potting

As long as the core height is less than or equal to the minimum necessary potting height, i.e. $h_c \leq h_i + 7$ mm, the potting is considered as 'full potting' where the potting height is equal to core height.

7.5.5.2 Partial potting

For partial potting, i.e. in this case ($h_c > h_i + 7 = 16$ mm), the minimum and typical values diverge; as shown in Figure 7-4.

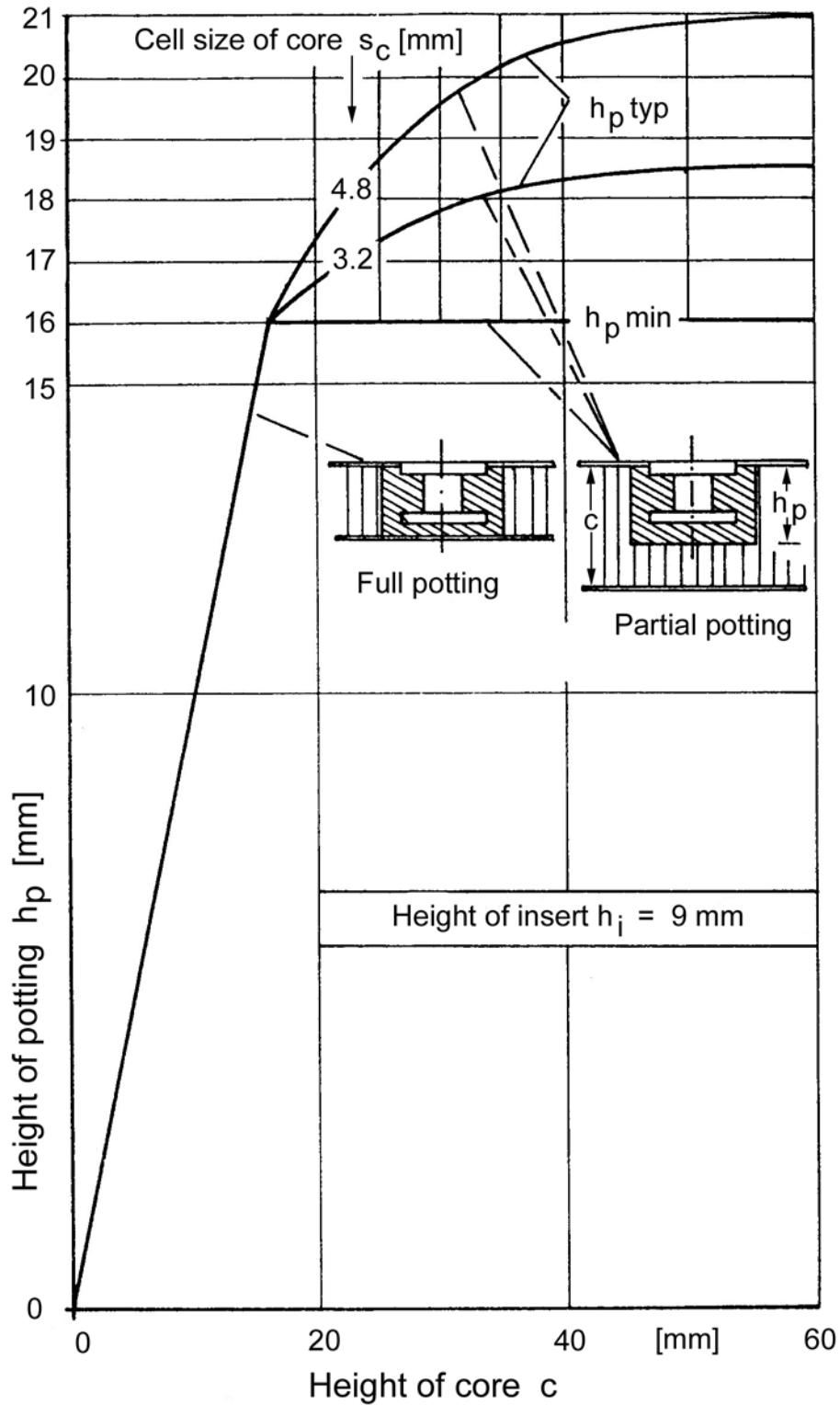

Figure 7-4: Potting height as a function of the honeycomb core height

7.6 Potting mass

An estimation of the potting mass is used to determine the overall structural mass.

7.6.1 Effect of core and insert characteristics

Figure 7-5 shows that the weight of potting depends on the:

- Core height:
- Cell size;
- Insert diameter.

The values are based on an insert height of 9 mm and a diameter of 14 mm, fully potted up to a core height of 16 mm, and partially potted at greater core heights.

7.6.1.1 Other insert heights

The values in Figure 7-5 were not corrected by the weight coefficients from Figure 7-6 for insert heights other than 9 mm.

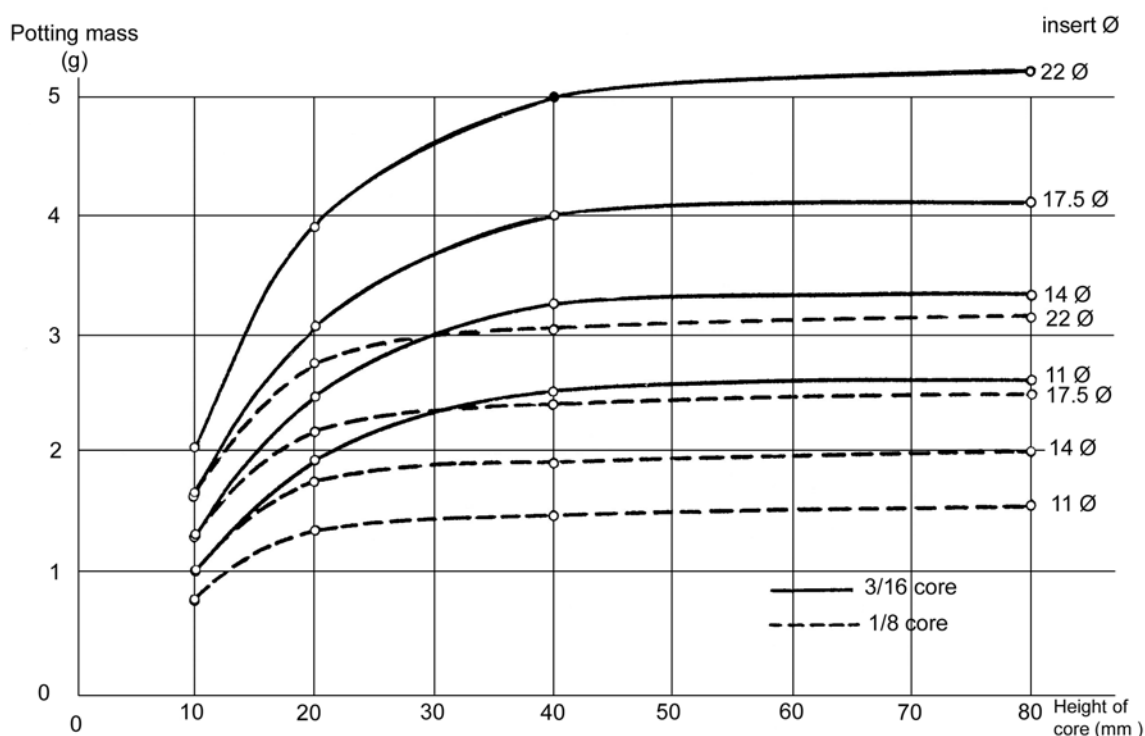

Figure 7-5: Mean weight of potting masses versus core height and insert diameter

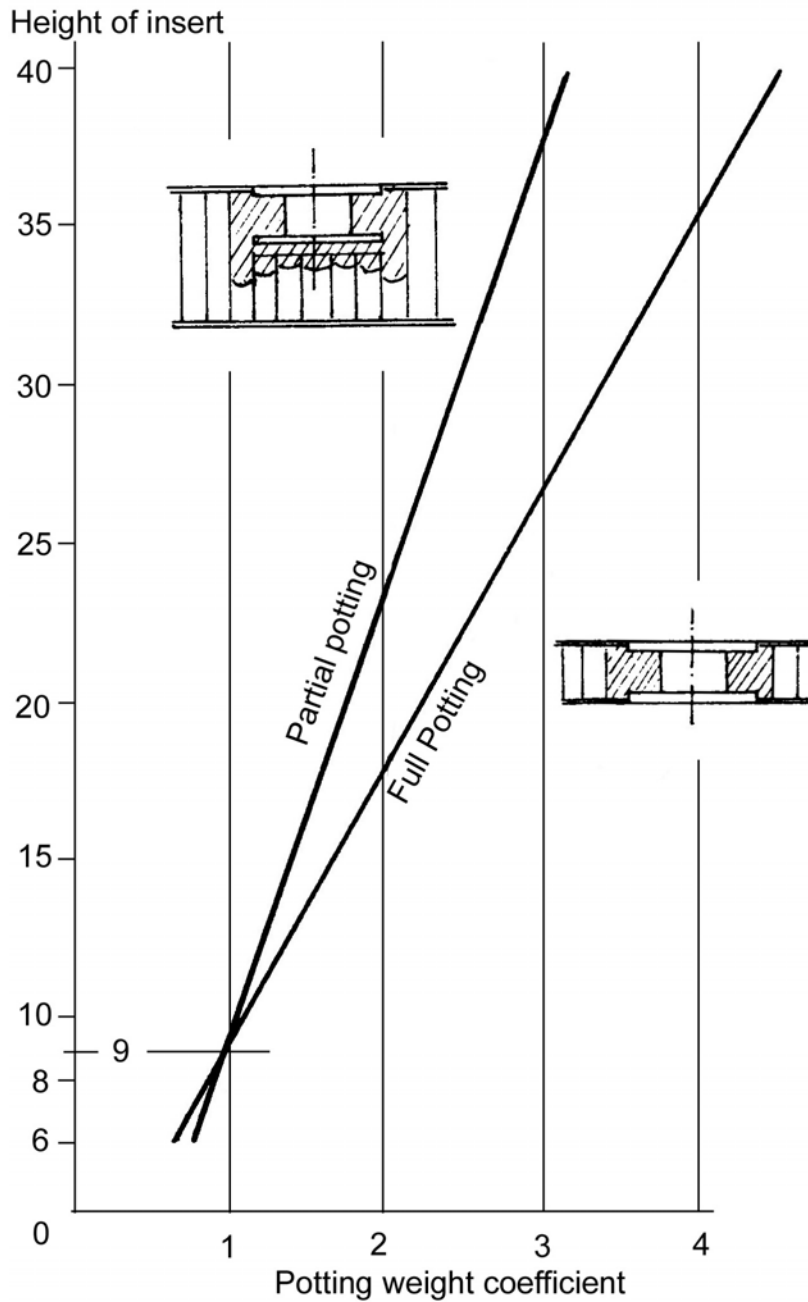

Figure 7-6: Correction coefficient for weight of insert heights

7.6.1.2 Partial and full potting

Two cases can be distinguished in Figure 7-6:

- Partial potting, and
- Full potting, i.e. the insert height is the same as the core height.

The weight data contains the mass of resin only.

NOTE Insert mass is determined from standards.[See also: Annex A].

7.6.2 Total mass of insert system

The total mass of an insert system is determined by:

- Potting mass, [See: Figure 7-5 and Figure 7-6];
- Mass of insert elements;

NOTE Insert mass is determined from standards.

- Reduced by:

- mass of face-sheet hole, given by:

$$f b_i^2 \pi \rho \quad [7.6-1]$$

- mass of removed core (negligible).

7.7 References

7.7.1 General

- [7-1] ERA Technology Ltd. / RJ Technical Consultants
 'Insert Technology for Space Applications'
 European Industrial Survey 1995
- [7-2] 'Standardisation of Design Analysis and Testing of Inserts in Structural Elements'.
 Final report. ESTEC Contract No. 3442/77/NL/PP - Rider 1
- [7-3] 'Matra Marconi Space Contribution to ESA Insert Design Handbook';
 MMS Ref. NT/102/BG/355013.96 (Dec. 1996)
- [7-4] J. Block, R. Schütze, T. Brander, K. Marjoniemi, L. Syvänen, M. Lambert :
 DLR Braunschweig / Helsinki Univ. Technology/ Patria
 'Study on Carbon Fibre Tube Inserts',
 ESTEC Contract No. 16822/02/NL/PA, (2004)

7.7.2 ECSS standards

[See: ECSS website: www.ecss.nl]

- ECSS-Q-70-series Space product assurance
- ECSS-Q-70-71 Space product assurance - Data for the selection of space materials and processes
- ECSS-Q-ST-70-22 Space product assurance - Control of limited shelf-life materials

8

Mechanics of sandwich structures

8.1 Structural sandwich concept

The American Society for Testing and Materials (ASTM) defines a sandwich structure as:

‘A structural sandwich is a special form of a laminated composite comprising of a combination of different materials that are bonded together so as to utilise the properties of each separate component to the structural advantage of the whole assembly’.

Although this definition is not very specific, it covers the type of structural sandwich panels most often appearing in modern structural applications. Such sandwich panels, as shown in Figure 8-1, can be in the form of beams, plates or shells all of which have three main constituents:

- An upper face sheet;
- A lower face sheet;
- A core material.

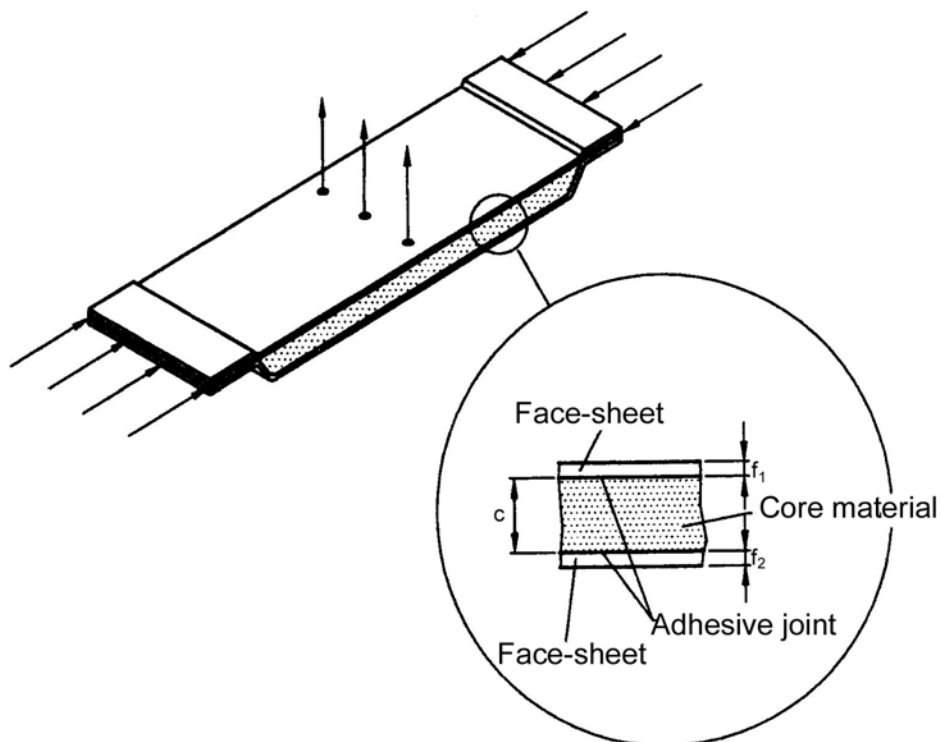

Figure 8-1: Schematic of structural sandwich panel subjected to both in-plane and out-of-plane external loading

A sandwich assembly consists of two thin, stiff and strong face sheets separated by a thick, light, compliant and weaker core material, [See: Figure 8-1]. The face sheets are adhesively bonded to the core to enable load transfer between the components.

In a structural sandwich, the face sheets act together to form an efficient stress couple counteracting the external bending load, whereas the core resists shear and stabilises the face sheets against buckling.

The advantages given by such a design concept are numerous, including:

- High stiffness to weight ratio;
- High strength to weight ratio;
- Integration of functions, such as thermal and acoustic insulation;
- High energy absorption capability;
- Few design details.

However, given the list of advantages, currently the most important drawbacks are:

- Complicated quality control;
- Loading and joining difficulties, including the use of inserts;
- Lack of knowledge concerning the effect of damage.

8.1.1 Properties of constituent materials

8.1.1.1 General

The design of a structural sandwich panel is an integrated process of sizing and materials selection, and it is the task of the designer to utilise each material component to its limit.

8.1.1.2 Face sheets

The properties of primary interest for the face sheets, also known as skins, are:

- High stiffness;
- High tensile and compressive strengths;
- Impact resistance;
- Environmental resistance, e.g. thermal, chemical UV;
- Surface finish.

Commonly used face sheet materials for spacecraft applications are aluminium alloys and CFRP.

8.1.1.3 Core

The core material is just as important as the face sheet material, even though it does not appear so at first. Usually it is the material component that the design engineer has the least knowledge of.

The properties of primary interest for the core can be summarised as:

- Low density;
- High stiffness and strength perpendicular to face sheets;
- High shear stiffness and shear strength;

- Thermal conductivity (low or high dependent on the actual application);
- Dielectric properties, e.g. for antenna applications.

Commonly used core materials for spacecraft applications are aluminium, Nomex® and GFRP honeycombs, and more rarely polymeric cellular foams, such as PVC or polyurethane foams.

8.1.2 Fundamentals of classical ‘antiplane’ sandwich theory

The fundamentals of sandwich theory, i.e. the mathematical description of the mechanical behaviour of sandwich structures, can be found in textbooks; such as [Ref. [8-1], [8-2], [8-3], [8-4]]. However, a brief review of the simplest possible sandwich theory is presented.

The simplest theories of sandwich beams, plates and shells are in many respects similar to the classical engineering theories of beams, plates and shells with the exception that the transverse shear deformations should be accounted for. Furthermore, sandwich theories account for the fact that different load types are carried by different parts of the structures. For simplicity, only sandwich beams are treated here, but all the basics also extend to sandwich plates and shells. The sign conventions for the beam displacements w and u , the bending moment M and the transverse shear force Q are shown in Figure 8-2.

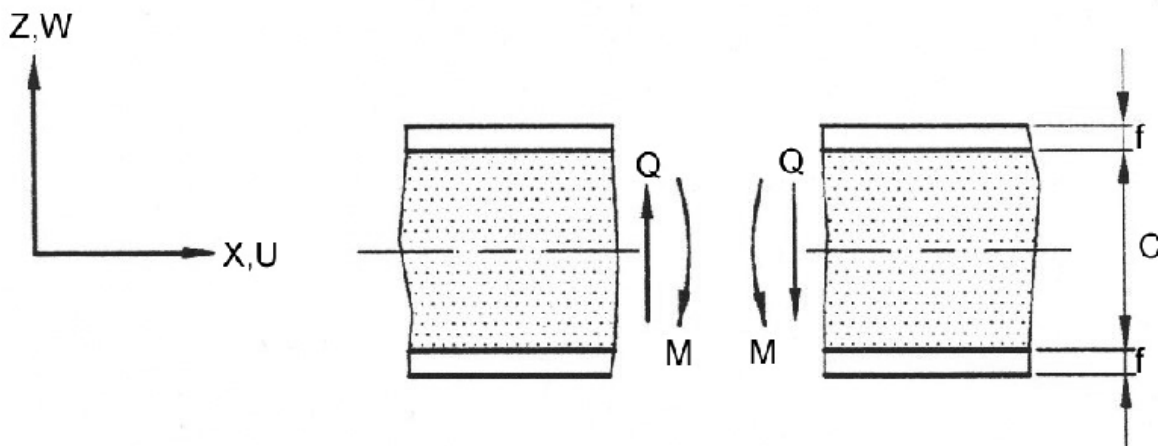

Figure 8-2: Sign conventions for sandwich beam element

Consider a sandwich beam subjected to arbitrary external support and loading conditions, and assume that the face sheets are identical, i.e. $f_1 = f_2 = f$.

For such a sandwich beam, it is recognised that two deflection parts contribute to the overall deflection pattern; as shown in Figure 8-3:

- Deflections due to bending moments: bending - w_b
- Deflections due to transverse forces: shearing - w_s

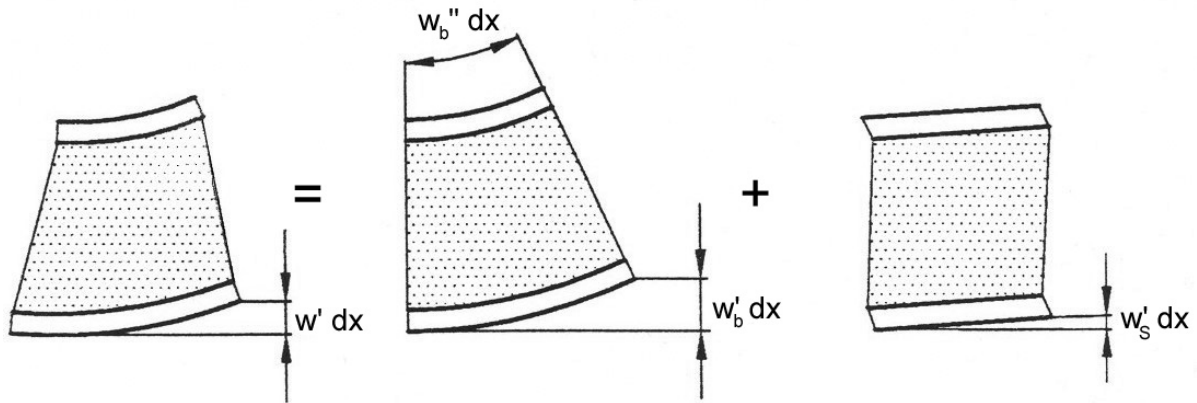

Figure 8-3: Deformed sandwich beam element: deflection contributions from both bending and shearing

For a sandwich beam with thin face sheets (compared with the core thickness), the two deflection parts may be superimposed as (partial deflections approach):

$$w = w_b + w_s \quad [8.1-1]$$

The bending displacement w_b is calculated according to classical beam theory:

$$\frac{d^2 w}{dx^2} = -\frac{M}{D} \Rightarrow \quad [8.1-2]$$

$$w_b = -\iint \frac{M}{D} dx dx + C_1 x + C_2$$

Where:

C_1 and C_2 are integration constants to be determined from the boundary conditions of the problem;

D is the flexural rigidity of the sandwich beam.

For sandwich beams with identical face sheets the flexural rigidity D can be expressed as:

$$D = b \left[E_f \left\{ \frac{f^3}{6} + \frac{f(c+f)^2}{2} \right\} + E_c \frac{c^3}{12} \right] \quad [8.1-3]$$

Where:

b width of the sandwich beam

E_f elastic moduli of the face material.

E_c elastic moduli of the core material.

For sandwich beams with thin face sheets and low stiffness core material Eqn. [8.1-3] can be approximated by:

$$D \approx E_f \frac{bf(c+f)^2}{2} \quad \text{For } f \ll c \text{ and } E_f \gg E_c$$

The expression given for D in Eqn. [8.1-4] corresponds to $E_c \approx 0$, which in [Ref. [8-2]] is referred to as an 'antiplane' core (the in-plane stiffness of the core material is negligible).

The shearing deflection w_s corresponding to overall shearing of the sandwich beam is shown in Figure 8-4, where it is assumed that the shearing deformation only occurs in the core, i.e. $G_f = \infty$, and that this deformation is linear (assuming constant core shearing strain and stress over the core thickness).

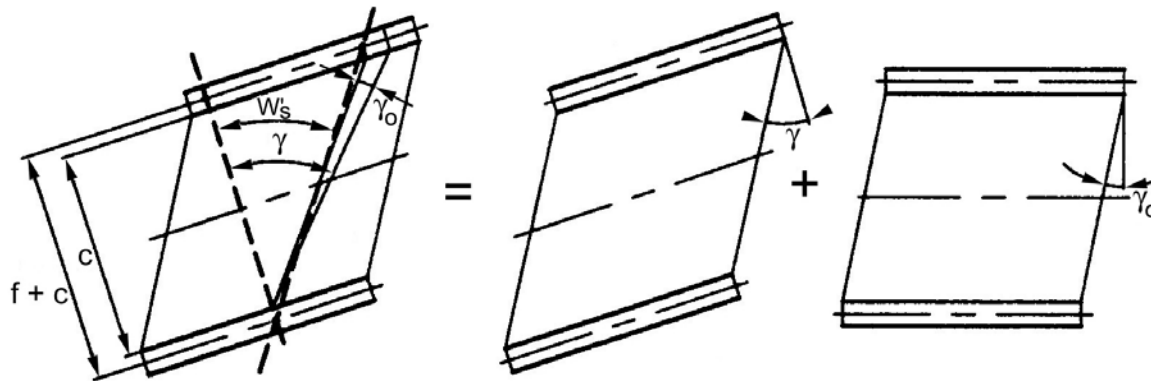

NOTE Shearing deformation of sandwich beam element ($w'_s \equiv dw_s/dx$).

Figure 8-4 Shearing deformation of sandwich beam element

As shown in Figure 8-4, the shearing angle can be divided into a transverse, γ and an in-plane part, γ_0 . The in-plane shearing angle γ_0 can be expressed as:

$$\gamma_0 = \frac{u_{upper} - u_{lower}}{c} \quad [8.1-5]$$

Where:

u_{upper} *in-plane displacements of the upper face sheet.*

u_{lower} *in-plane displacements of the lower face sheet.*

From Figure 8-4, the geometrical relation found is:

$$\frac{dw_s}{dx} = (\gamma - \gamma_0) \frac{c}{(c+f)} \quad [8.1-6]$$

The shearing strain in the core material is constant, and is associated with a shearing stress τ_c that is also constant through the depth of the core.

The transverse shearing strain is defined as:

$$\gamma = \frac{\tau_c}{G_c} = \frac{Q}{G_c(c+f)} \quad [8.1-7]$$

Inserting Eqn. [8.1-7] into Eqn. [8.1-6] gives:

$$\frac{dw_s}{dx} = \frac{Q}{S} - \frac{\gamma_0 c}{(c+f)} \Rightarrow$$

$$w_s = \frac{M}{S} - \frac{\gamma_0 cx}{(c+f)} + C_3 \quad [8.1-8]$$

Where:

- C_3 an integration constant.
- S the sandwich beam shearing stiffness, which is defined by:

$$S = G_c \frac{(c+f)^2}{c} \quad [8.1-9]$$

Eqn. [8.1-9] together with Eqn. [8.1-2], constitutes the complete displacement solution to the sandwich beam problem.

Consequently there are four constants (C_1, C_2, C_3, γ_0), which are determined from the statement of the boundary conditions.

The stresses in the sandwich beam, i.e. the normal stresses in the face sheets (the face sheet shearing stresses are usually ignored) and the normal and shearing stresses in core material can be approximated in the form (valid for $E_c \ll E_f$ and $f \ll c$):

$$\sigma_{xf} = \frac{Mz}{D} E_f \text{ where } \begin{cases} \frac{c}{2} + f \geq z \geq \frac{c}{2} \\ -\frac{c}{2} \geq z \geq -(\frac{c}{2} + f) \end{cases} \quad [8.1-10]$$

$$\sigma_{xc} = \frac{Mz}{D} E_c \text{ where } \frac{c}{2} \geq z \geq -\frac{c}{2}$$

$$\tau_c = \frac{Q}{b(c+f)}$$

Usually the in-plane core normal stress σ_{xc} is of insignificant magnitude and is therefore ignored, i.e.:

$$E_c = 0 \Rightarrow \sigma_{xc} \equiv 0 \text{ for 'antiplane' core.}$$

8.1.2.1 Application

The principles applied in the derivations presented provide a very simple theory, which nevertheless includes the main features of the mechanics of sandwich beams. Thus the theory accounts for:

- The face sheets carry the bending moment loading and the core carries the transverse shear loading.
- Both bending and shearing contributes significantly to the deformations.

The derived theory is valid for sandwich beams, but the same principles also apply for a sandwich plate and shell theories.

In the derivations it was assumed that the thickness of the face sheets was thin compared with the core thickness, but the theory can be extended to sandwich panels with thick face sheets.

This complicates the theory as the bending stiffness of the face sheets themselves cannot be ignored in the case of thick face sheets.

However, sandwich panels for spacecraft applications are usually characterised by having very thin face sheets compared with the core thickness, and the simple sandwich theory presented herein provides accurate results with respect to prediction of 'global' load response characteristics.

8.2 Structural failure modes

Sandwich panels fail when they are subjected to some type of overloading conditions. Sandwich panels can fail in many different ways, where each failure mode gives a constraint on the load-bearing capacity of the considered sandwich.

Which failure mode becomes active in a given situation depends on the geometry, material data and external load conditions. Hence the geometry, material data and external load conditions also determines the performance limits of a sandwich structure.

A summary of the most important failure modes for sandwich panels is shown in Figure 8-5

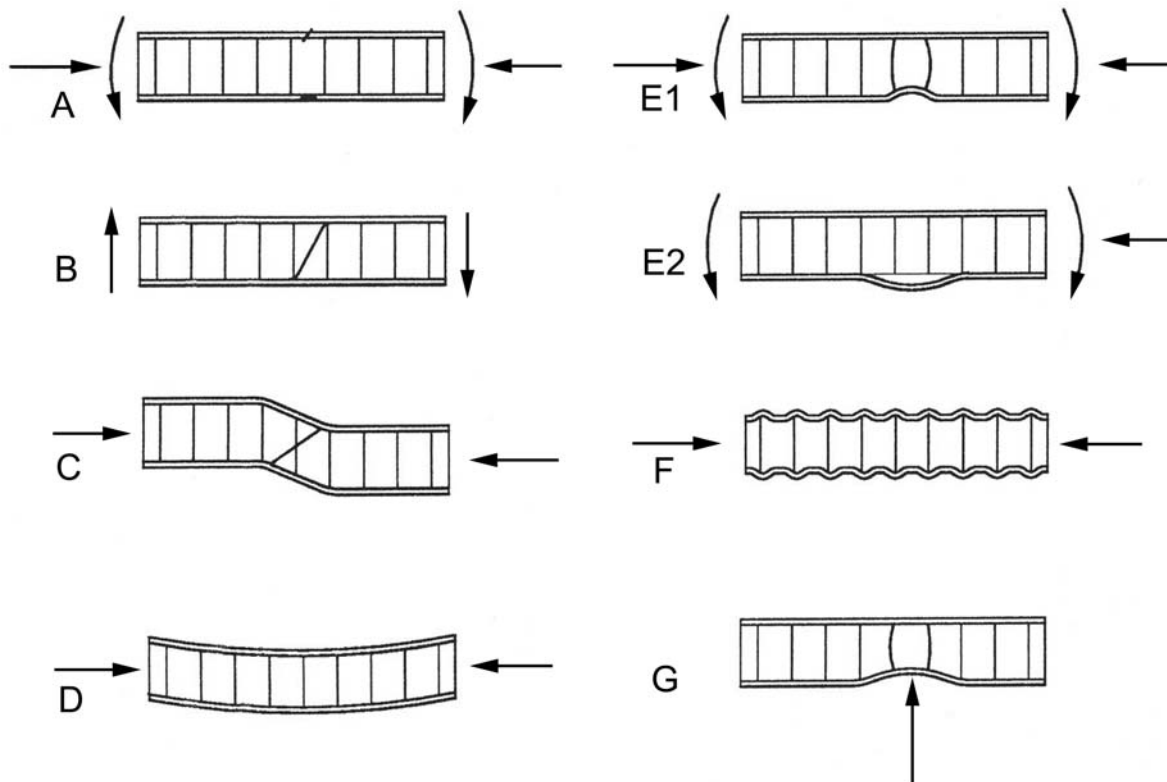

- (A) Face yielding/fracture.
- (B) Core shear.
- (C) Shear crimping.
- (D) General buckling.
- (E1) and (E2) Face wrinkling (local buckling).
- (F) Face dimpling (intercell buckling)
- (G) Local indentation ('local' bending of face sheet).

Figure 8-5: Failure modes: Honeycomb core sandwich panels The failure modes can be grouped as, [See: Figure 8-5]:

- Global: (A) to (D) are associated with the 'global' load response characteristics of the sandwich panel.
- Local: (E) to (G) are associated with 'local' load response characteristics, or just 'local' effects.

NOTE The concept of 'local' effects in this context refers to scenarios where the face sheets tend to bend about their own mid-surfaces rather than about the mid-surface of the sandwich panel.

8.2.1 **Global failure modes**

Global failure modes can, in principle, be accounted for using the simple classical 'antiplane' type of sandwich theory; [See: 8.1].

NOTE Details are given in [Ref. [8-1], [8-2], [8-3], [8-4]].

8.2.2 **Local failure modes**

Local failure mode types, however, cannot be accounted for using a classical 'antiplane' type of sandwich theory, as these failure modes are associated with local bending effects.

Where load introduction through 'hard points', such as inserts, in sandwich structures is of real interest, the 'local' bending phenomena, as shown by failure mode (G) play an important role; [See: Figure 8-5].

NOTE A summary and discussion of 'global' and 'local' failure modes of structural sandwich panels is given in ECSS-E-HB- 32-20.

8.3 **Load introduction aspects and discontinuities**

8.3.1 **General**

A simple sandwich theory which includes the most important aspects of the mechanics of sandwich panels (at least with respect to prediction of 'global' load response characteristics) is outlined in 8.1. The possible or likely failure modes are discussed in 8.2.

The causes of 'local' bending effects are described further here.

The simple classical 'antiplane' type of theory, [See: 8.1], is based on the assumption that the distance $c + f$ between the middle surfaces of the face sheets remains unchanged during deformation, [See: Figure 8-2]. Thus, it is implicitly assumed, that the transverse stiffness of the core material (E_c in the thickness direction) is infinitely large. Obviously, this is not true, and in regions of load introduction as well as in regions where material and geometric discontinuities are present, the assumption of constant sandwich panel thickness does not hold.

In such regions the face sheets tend to act as beams or plates bending about their own middle surface, and significant transverse normal and shear stress concentrations are present in the interfaces between the face sheets and the core material.

The simplest possible case of local bending in a sandwich beam is given in Figure 8-6, [Ref. [8-4]], which shows a sandwich beam under 3-point bending.

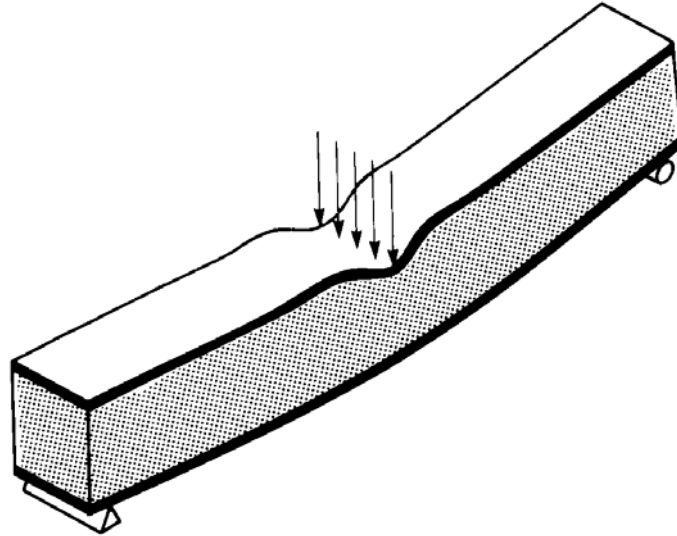

Figure 8-6: Schematic of 'local' bending effects in sandwich beam subjected to 3-point bending

It shows that the sandwich beam responds to the load in two ways:

- Global load response, which can be accounted for using the simple classical 'antiplane' sandwich beam theory, and a
- Local bending response, which cannot be accounted for using simple classical 'antiplane' sandwich beam theory.

8.3.2 Local bending response

The 'local' bending response is characterised by a 'wavy harmonic' nature and a very steep decay away from the point or area of load application, e.g. supports, geometry change, material change or other discontinuous phenomena.

The 'local' bending causes the inducement of severe stress concentrations, and failure modes can be the cause of structural failure are:

- Shear failure of the core;
- Crushing of the core (indentation failure);
- Delamination in interfaces between core and face sheets;
- Tensile or compressive failure of the face sheets;
- Delamination of the loaded face sheet for sandwich panels with laminated FRP faces.

The type of 'local' bending effects, as shown in Figure 8-6, is characteristic for the 'local' effects generally seen in structural sandwich panels. Thus, the same 'local' effects are active in one way or the other in cases where:

- Sandwich panels subjected to localised external loading;
- Sandwich panels with localised support conditions;
- Sandwich panels with face sheets with thickness 'drop-offs', e.g. tapered FRP faces; debonds, discontinuous change of core properties;

- Joints between adjoining structural sandwich panels or sandwich panels and monolithic structural components, e.g. T-joints, corner joints;
- Sandwich panels with inserts and mechanical fasteners.

8.3.3 Antiplane-type theory

The design formulas derived from the classical ‘antiplane’ type of sandwich theory cannot provide any meaningful answers in areas of load introduction, or material and geometric discontinuities. Thus, it is usual practice to adopt other methods of analysis, if such localised phenomena are present. Which kind of theory is necessary, in order to include such localised phenomena in the analysis, depends on the actual problem addressed.

8.3.4 Finite element analysis

Obviously, detailed finite element analysis, based on the use of several layers of solid elements for the core material and the use of plate or shell elements (or several layers of solid elements) for the face sheets, are able to provide accurate predictions (except for problems with stress singularities) of the local response characteristics in areas where ‘local’ bending phenomena cannot be ignored. This, however, is a very costly solution, and the required modelling efforts alone make this option unattractive for most purposes.

8.3.5 Elastic foundation model

Localised load introduction problems, [See: Figure 8-5], can be analysed satisfactorily in simple cases by considering the loaded face sheets as beams or plates on an ‘elastic foundation’ (the core material).

The elastic foundation model can provide a good estimate of the stresses induced by ‘local’ bending.

Superposition of the local bending stresses with the ‘global’ stresses, predicted by classical ‘antiplane’ theory, provide an accurate prediction of the stress state in the highly-stressed regions.

NOTE The implementation of this approximate method can be found in [Ref. [8-4]].

8.3.6 Transverse flexibility

For the more general cases of ‘local’ bending, i.e. cases where ‘local’ bending effects influence the elastic response of the face sheets as well as the core, more sophisticated mechanical models are needed.

The key point is for the theory to include the ‘transverse flexibility’ of the core material, i.e. to account for the fact that the thickness of the sandwich panel does not remain constant during deformation, and that the two face sheets can deflect differently.

8.3.7 Higher-order sandwich beam theory

Including the ‘transverse flexibility’ of the core is important when addressing load-introduction problems, support problems, and problems involving material and geometric discontinuities in sandwich beams, [Ref. [8-6], [8-7], [8-8]].

This was done by formulating a ‘higher-order’ sandwich beam theory, which includes separate descriptions of each face sheet and separate description of the core material. The core material is

modelled as a special type of transversely isotropic solid where only the out-of-plane stiffness is accounted for. The principles behind this higher-order sandwich beam theory has been adapted and extended, [Ref. [8-9], [8-10]], with the purpose of analysing sandwich plates with inserts (potted inserts of the 'through-the-thickness' and 'fully potted' types).

Unfortunately, the 'higher-order' theories are much more complex than the simple classical 'antiplane' theories in a mathematical sense. It is not possible to derive simple design formulae from the higher-order theories because they cannot be solved in closed form. Their solutions can only be achieved using a numerical approach.

The higher-order theories can, however, account for the 'local' bending effects leading to structural failure of sandwich panels in quantitative terms.

[See: 8.5 for a discussion of these design theories]

8.4 Sandwich plates with potted inserts

The handbook focuses on inserts potted by means of a curing epoxy resin, the most important group of inserts [See: Figure 8-7].

Information on non-standard designs, where classical potting is replaced by an alternative procedure, are also discussed, [See: A.3 and F.6].

8.4.1 Classification of potted insert types

Figure 8-7 shows the three different types of potted inserts. Their static load-carrying capability can be ranked as:

- Through-the-thickness highest
- Fully potted ↓
- Partially potted lowest

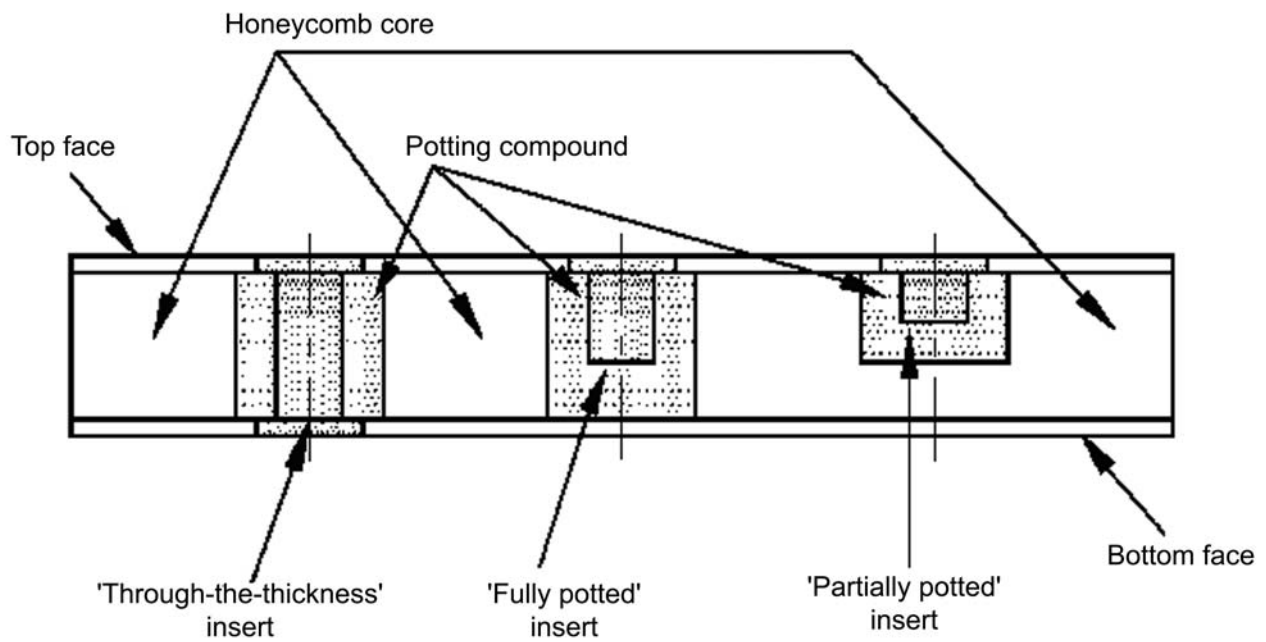

Figure 8-7: Schematic of potted insert types for sandwich panels used for spacecraft applications

8.4.2 Load transfer

Of the three different types of potted inserts, the load-transfer mechanisms associated with 'through-the-thickness' inserts are the simplest, even though the word 'simple' in this context is misleading.

The basics of the load transfer in sandwich panels 'through-the-thickness' inserts are considered and a few important features summarised.

NOTE A complete description of the mechanical response of sandwich plates with 'through-the-thickness' inserts is beyond the scope of this handbook.

8.4.3 External load cases

Details about the mathematical modelling using a higher-order sandwich plate theory, as well as detailed results obtained for the various axisymmetric and non-axisymmetric load cases, as shown in Figure 8-8, are given in [Ref. [8-9], [8-10]].

[See also: 8.5 for a summary of using 'higher-order' theory versus classical 'antiplane' theory]

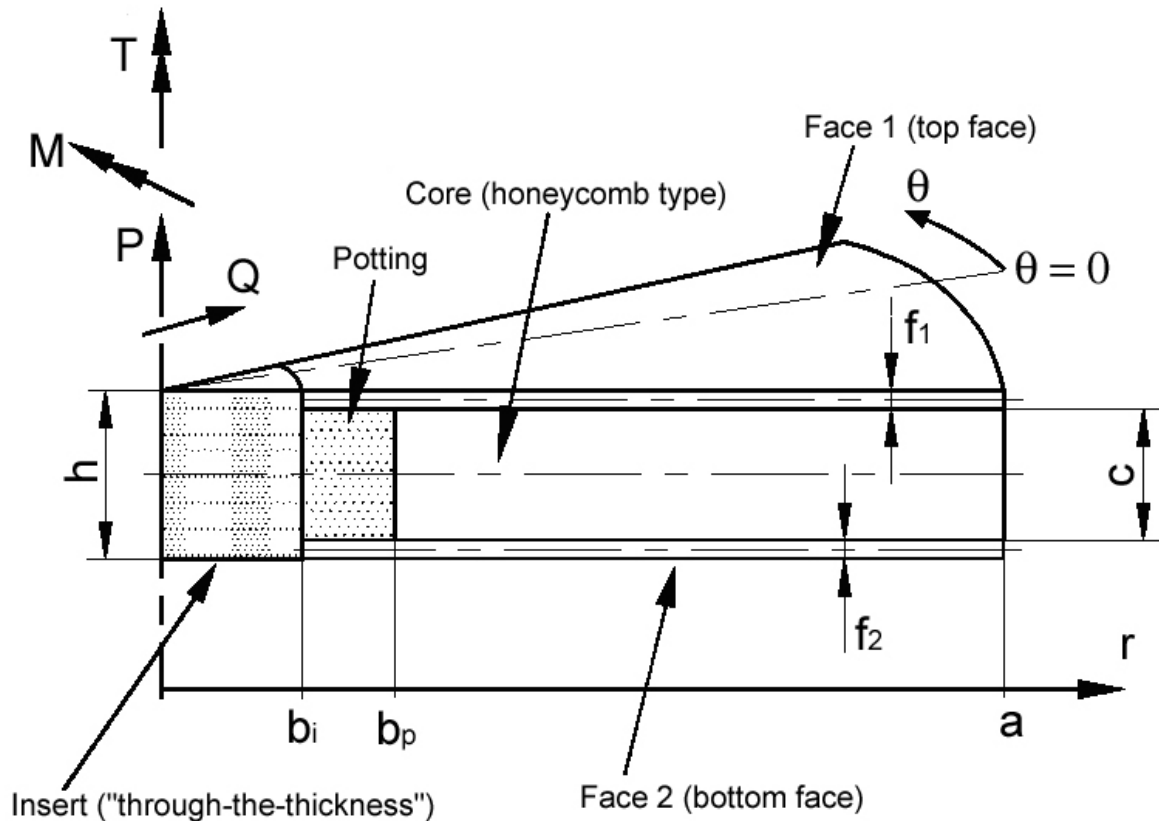

Figure 8-8: Model definition of sandwich plate with 'through-the-thickness' insert

In the modelling of a sandwich plate with an insert, it is assumed that the interaction between adjacent inserts, as well as the interaction between the considered insert and the plate boundaries or other sources of local disturbances, can be ignored.

Figure 8-8 defines the constituent parts, the geometry as well as the possible external load cases. The sharp separation between the potting and the honeycomb core, [See: Figure 8-8] is a strong idealisation, as the potting-to-honeycomb intersection is not defined precisely in a geometrical sense, [See also: Figure D-1].

The boundary conditions imposed in the analysis are:

- $r = b_i$: the 'through-the thickness' insert is considered as an infinitely rigid body to which the face sheets and the potting material are rigidly connected (clamping conditions);
- $r = b_p$: continuity of solution across potting-to-honeycomb intersection;
- $r = a$: it is assumed that the face sheets as well as the honeycomb midsurface are simply supported, enabling shear stress transfer in both face sheets and core.

8.4.4 Example

8.4.4.1 Symmetric sandwich plate with insert subjected to out-of-plane load

This applies to an insert subjected to out-of-plane load investigated with higher-order theory. Some results are presented for the case of a circular sandwich plate with a ‘through-the-thickness’ insert, [See also: 8.5; Annex D; Figure D-1].

It is assumed, that the insert is subjected to an out-of-plane load P (axisymmetric load case), and that the two face sheets of the sandwich are identical.

NOTE A numerical solution is used because the boundary value problem constituted by the governing equations, defined by the adopted ‘high-order’ sandwich plate theory [See also: 8.5] that can be classified as a third order shear deformation plate theory, and the prescribed boundary conditions, cannot be solved in ‘closed-form’ for the case of a circular plate with an insert subjected to various external loadings, [Ref. [8-15], [8-16], [8-17]].

The geometry, material and external load data are:

- Geometry: $b_i = 10\text{mm}$; $b_p = 30\text{mm}$; $a = 150\text{mm}$; $c = 10\text{mm}$; and $f_1 = f_2 = 1\text{mm}$.
- Top face sheet: quasi-isotropic FRP-laminate, $E_{f1} = 40\text{ GPa}$, $\nu_{f1} = 0.3$.
- Bottom face sheet, same as top face sheet, i.e. $E_{f2} = E_{f1}$; $\nu_{f2} = \nu_{f1}$.
- Potting compound: bulk epoxy, $E_p = 2.5\text{GPa}$; $G_p = 0.93\text{GPa}$.
- Honeycomb core: honeycomb 3/16"-5056-0.0007"; Properties: $E_h = 310\text{MPa}$; $G_h \approx (G_W + G_L)/2 = 138\text{MPa}$.
- Insert: through-the-thickness; $h_i = f_1 + c + f_2 = 12\text{mm}$.
- External load: compressive out-of-plane load; $P = -1\text{kN}$

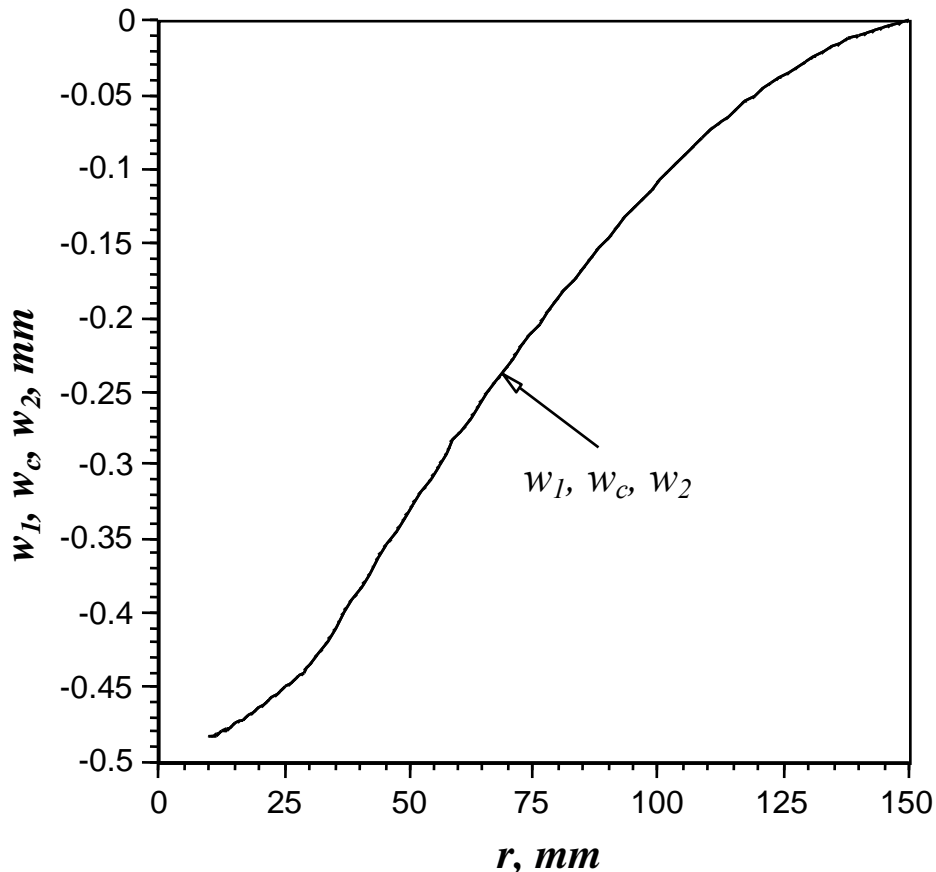

NOTE Out-of-plane displacements (core midsurface): w_1, w_2, w_c .
 Load: Compressive (out-of-plane) $P = -1\text{kN}$
 Theory: Numerical higher order

Figure 8-9: Example: Lateral displacements of a symmetric sandwich plate with insert subjected to compressive out-of-plane load

Figure 8-9 shows the out-of-plane (lateral) deflections of the face sheets (w_1, w_2), and the core midsurface, w_c . In Figure 8-9, Figure 8-10 and Figure 8-11, $r \leq b_p = 30\text{mm}$ corresponds to the potting region, whereas $r > 30\text{mm}$ corresponds to the honeycomb region.

From the results, [See: Figure 8-9], the out-of-plane (lateral) deflections of the two face sheets and the core material midsurfaces are almost identical.

As expected due to the symmetry of the sandwich plate considered, the out-of-plane (lateral) displacements of the two face sheets w_1, w_2 are identical.

The mid-surface, out-of-plane (lateral) displacement of the core material w_c (potting and honeycomb), however, is slightly different from w_1, w_2 close to the insert-to-potting and potting-to-honeycomb interfaces (difficult to see on the figure), where the core changes abruptly. The difference between the out-of-plane (lateral) face sheet and core displacements, encountered at these locations, causes the inducement of transverse normal stresses (σ_c) in the potting and the honeycomb core.

Figure 8-10 shows the stress distribution in the core material. The values of the transverse normal stress σ_c are given at the interface between the top face sheet and the core ($\sigma_{c\ top}$) and at the interface between the bottom face and the core ($\sigma_{c\ bottom}$).

According to the higher-order sandwich plate theory, σ_c varies linearly over the core thickness.

Figure 8-10 also shows the distribution of the transverse core shear stress component τ_c , which is assumed to be constant over the height of the core material.

Considering the σ_c -distribution, the presence of transverse normal stresses is a local phenomenon, as significant σ_c contributions are only present close to $r = b_i = 10$ mm (i.e. close to the insert) and close to $r = b_p = 30$ mm (i.e. close to the potting-to-honeycomb intersection). Also, $\sigma_{c\ top}$ and $\sigma_{c\ bottom}$ are of opposite signs, i.e. when one is compressive the other is tensile and vice versa.

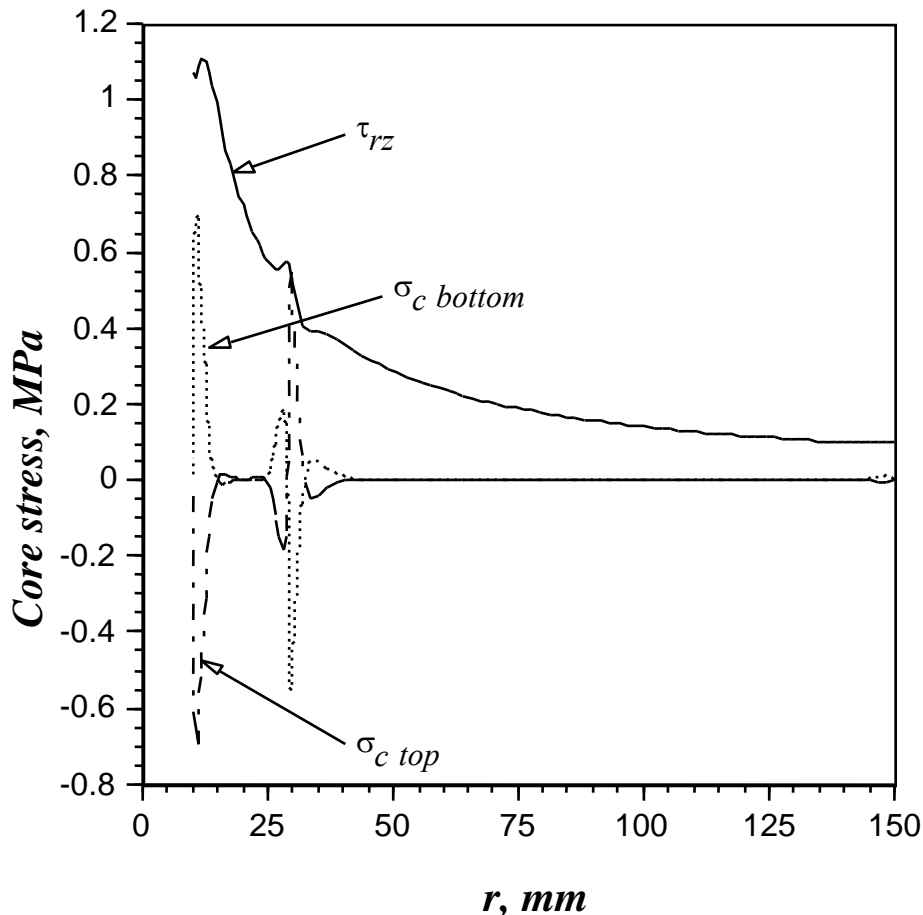

NOTE Core stress components: $\tau_{rz} = \tau_c$, $\sigma_{c\ top}$, $\sigma_{c\ bottom}$
 Load: Compressive (out-of-plane) $P = -1$ kN
 Theory: Numerical higher order

Figure 8-10: Example: Core stress components of symmetric sandwich plate with insert subjected to out-of-plane compressive force

Considering the shear stress distribution in the core material, the overall tendency is that τ_c decreases with increasing r -values. The overall tendency of decreasing τ_c -values with increasing r is a consequence of the fact that the total transverse shear stress resultant $P_{r\ total} = P_{r1} + P_{r2} + c\tau_c$ is inversely proportional to r (vertical equilibrium, $P = 2\pi r P_{r\ total}$), and that the main part of P is carried by the core material, i.e. by τ_c .

Figure 8-10 also shows that the abrupt change of core stiffness at the potting-to honeycomb intersection only causes minor fluctuations of the τ_c -distribution.

Pertaining to the combined influence of the transverse normal and the shear stress components on the potting and honeycomb materials, the mechanical properties of the two materials are very different. Thus, the stiffness and strength properties of the honeycomb material are usually an order of magnitude lower than those of the potting.

From Figure 8-10, the magnitude of the peak stresses in the potting and honeycomb regions are of about the same magnitude, so a 'weak spot' is located at the position of the potting-to-honeycomb intersection (at $r=b_p$) as well as a short distance into the honeycomb material.

It is concluded that the stress concentrations in the potting region (closest to the insert) are not likely to cause a failure, except for the possibility of failure due to weak bonds between the insert and the potting as well as between the face sheets and the potting. However, the stress concentrations encountered at the potting-to-honeycomb intersection and immediately after that, can provoke a premature failure.

The active failure mechanisms are likely to be one out of three:

- Honeycomb top-surface: Tensile $\sigma_{c_{top}}$ -stresses can cause a failure in the (weak) bond between the top face sheet and the honeycomb.
- Potting-to-honeycomb intersection: Shear τ_c -stresses can cause a shear rupture of the core surrounding the potting material.
- Honeycomb bottom-surface: Compressive $\sigma_{c_{bottom}}$ -stresses can cause a compression failure (buckling) of the honeycomb cells.

In practice, core shear rupture is the cause of structural failure in most cases, i.e. failure at the potting-to-honeycomb intersection, Ref. [[8-11], [8-12]].

Figure 8-11 shows the distribution of the radial bending moment resultants M_{r1} , M_{r2} ; where M_{r1} and M_{r2} are identical (due to the symmetry) and that they attain their peak values at the insert-to-potting intersection ($r=b_i=10\text{mm}$). The location of the peak bending moment resultants is due to the restrictive boundary conditions imposed by the insert (clamping). Another local peak is seen around the potting-to-honeycomb intersection at $r=b_p$ but the decay of M_{r1} , M_{r2} is seen to be complete a short distance away from $r=b_p$.

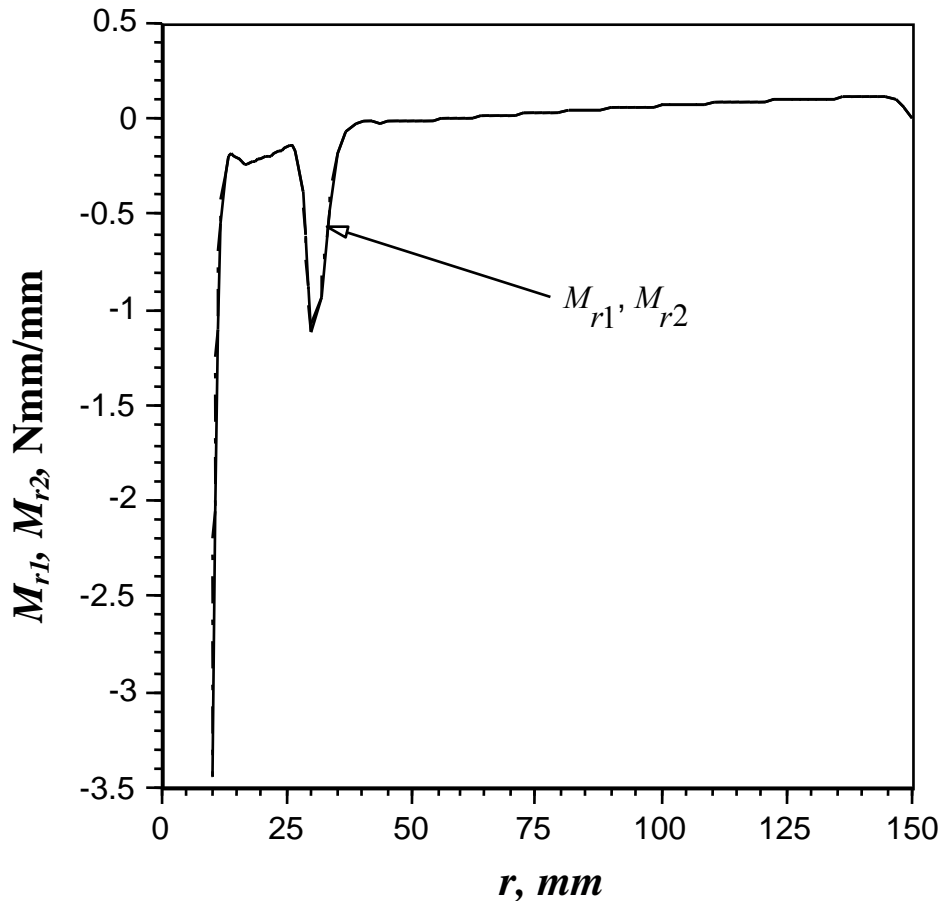

NOTE Radial bending moment resultants: M_{r1}, M_{r2}
 Load: Compressive (out-of-plane) $P = -1$ kN
 Theory: Numerical higher order

Figure 8-11: Example: Radial bending moment resultants in face sheets of symmetric sandwich plate with insert subjected to out-of-plane compressive force

These results demonstrate that complicated load-transfer mechanisms are active in sandwich plates with inserts. This is especially pronounced in the regions close to the insert and close to the potting-to-honeycomb interface, i.e. in regions where significant changes of geometry and stiffness properties take place.

Away from the locations of discontinuous change of geometry or material properties, the core material carries the load in pure shear and no local stress concentrations are present. In these regions classical 'antiplane' sandwich plate theory is capable of describing the stress state accurately, [See also: 8.5 for a brief summary of using 'higher-order' theory versus classical 'antiplane' theory].

8.4.5 Purpose of the potting compound

8.4.5.1 General

The actual purpose or function of the potting compound in the insert-to-sandwich plate system has two roles.

8.4.5.2 Primary function

The potting material provides the connection between the insert and the honeycomb material to ensure that a proper shear load-transfer can be accomplished between the insert and the honeycomb material. This connecting function is obtained when the potting compound is injected and flows into those of the honeycomb cells that have been left open during machining (in preparation of the hole for the insert).

8.4.5.3 Secondary function

The potting material participates in the overall load-transfer, and is less obviously recognised than the 'simple' connecting primary function mentioned. Thus, the potting compound plays a significant role in the load-transfer in insert-sandwich plate systems subjected to especially 'transverse' load types, i.e. P and M load cases, [See: Figure 8-8]. This is because the presence of a potting compound, which is usually 5 to 10 times stiffer than the honeycomb core material, causes a considerable relief of the peak bending and shear stresses in the face sheets (located adjacent to the insert). This stress-relieving function is achieved because the relatively stiff potting compound acts as an 'attractor' on the transverse shear stresses in the sandwich plate.

8.4.6 Design guidelines

A number of simple guidelines for the design of sandwich plates with potted insert are given, based on the results of extensive parametric studies, Ref. [[8-9], [8-10]].

8.4.6.1 Structural

Make the radial extension of the potting compound denoted by b_p-b_i , [See: Figure 8-8] as large as possible. b_p-b_i is of course very difficult to control in practice, as the potting radius b_p is determined by the flow of potting material into those of the honeycomb cells that have been left open during machining, i.e. b_p-b_i is determined by the manufacturing process. However, from a purely structural point of view, b_p-b_i of at least $0.5b_i$, ensures a maximum relief of the face sheet bending and shear stress concentrations, while, at the same time, the full shear stress transfer capability of the potting compound is utilised.

8.4.6.2 Stiffness

If possible, the ratio of the potting stiffness to the honeycomb stiffness, E_p/E_h , is chosen so that $E_p/E_h \approx 3$ to 4. This ensures a good compromise between the peak stress level in the face sheets and in the potting and honeycomb materials. Where $E_p/E_h < 3$ to 4, the peak bending and shear stresses in the face sheets are raised, while the transverse normal and shear stresses in the potting and honeycomb materials are decreased. The opposite is seen for $E_p/E_h > 3$ to 4.

The choice of potting stiffness properties invariably ends up being a trade-off between having the most severe stress concentrations in the face sheets or in the potting and honeycomb materials.

8.4.6.3 Bending and shear

The capability of the face sheets to resist the peak bending and shear stresses adjacent to the insert, can be improved considerably by reinforcing the face sheets in the zones where inserts are mounted. Such reinforcements, which are usually used for laminated FRP face sheets, can be made by adding extra plies (such as UD or multi-directional prepregs) on the outer surfaces of the face sheets. This has the effect of increasing the bending stiffness of the face sheets locally, thus causing a raise of the total shear load transfer through the face sheets. This causes a decrease of the peak stresses in the potting and honeycomb materials.

8.4.6.4 Bending moment

Load application through groups of inserts can avoid external bending moment loading, i.e. the M load case, [See: Figure 8-8]. This 'converts' the bending moment loading to transverse shear loads (out-of-plane loads).

8.4.6.5 Elongation

Potting and adhesive materials with long elongation to failure properties are needed to counter unavoidable significant stress concentrations in the potting material and in the bond lines between the honeycomb core and face sheets.

8.4.6.6 Severe loads

If severe external loads are introduced into sandwich panels, use 'through-the-thickness' rather than 'fully' or 'partially potted' inserts.

8.5 Remarks

8.5.1 General

The introduction to the mechanics of sandwich structures, [Ref. [8-14]] has provided an overall impression of the structural behaviour of sandwich structures, [See: 8.1], [See also: 8.4 for potted inserts].

8.5.2 Antiplane theories

Classical 'antiplane' sandwich theories are very useful for predicting 'global' load response characteristics, but that they are inadequate for explaining the complicated load-transfer mechanisms present around points or areas of load application, support, geometric and material discontinuities as well as inserts.

To obtain an accurate description of the structural response associated with such 'localised' effects, it is necessary to include the 'transverse flexibility' of the core material in the modelling. This can be done by refined finite element modelling or by adopting a 'higher-order' sandwich theory.

The obvious conclusion is that classical 'antiplane' sandwich theory cannot be used for predicting the load-bearing capability of sandwich plates with inserts subjected to arbitrary external loads. There is, however, one very important exception from this.

In the case of sandwich plates with inserts subjected to out-of-plane tensile or compressive loading, [See: Figure 8-8] the active failure mechanism is nearly always shear rupture of the honeycomb core at

the intersection between the potting and the honeycomb. The peak shear stress in the honeycomb material is located exactly at the potting-to-honeycomb intersection, and this stress component is predicted accurately by classical 'antiplane' sandwich theory.

In other words, for the out-of-plane load case classical 'antiplane' and 'higher-order' theories yield almost exactly the same results with respect to the predicted shear stress distribution in the potting and honeycomb materials, [See: Figure 8-10 for shear stress distribution]. Thus, it is possible to predict the load-bearing capability of sandwich plates with inserts subjected to out-of-plane loading using simple design formulas derived from classical 'antiplane' sandwich theory.

[See also: Annex D for design formulae; Annex B for design graphs (derived on the basis of these simple expressions)]

8.5.3 Higher-order theories

For the more complicated load cases, i.e. cases of sandwich panels with inserts subjected to non-axisymmetric or twisting loads, [See: Figure 8-8] classical 'antiplane' sandwich theory cannot be used for predicting the:

- Load response, or
- Load-bearing capability.

In these cases, a more refined modelling method should be used. This can be done with the 'higher-order' sandwich plate theory developed and adapted for the purposes of analysing sandwich plates with 'hard points' in the form of inserts, [Ref. [8-9], [8-10], [8-15] to [8-22]].

NOTE 1 When the mathematical 'high-order' sandwich plate theory, classified as a third order shear deformation theory, cannot be applied directly, a numerical solution can be considered instead, [See: 8.4.4 Example]. A general numerical solver, based on a technique known as 'multi segment method of integration' or 'multiple point shooting method' can be applied to the problem of inserts in sandwich panels in cases where the boundary conditions prevent a closed-form approach, [Ref. [8-15] to [8-23], inc].

NOTE 2 The results in Figure 8-9, Figure 8-10 and Figure 8-11 were derived using this approach, [See also: 8.4].

8.5.4 ESAComp[®]

ESAComp[®] is a software package for the design and analysis of composite laminates and structural elements for design engineers and stress analysts, available from Componeering Inc., Finland, [Ref. [8-13], [8-24]].

Addition of modules for the analysis of sandwich plates with 'through-the-thickness', 'fully potted' and 'partially potted' inserts under general load conditions, based on the higher-order sandwich plate theory are feasible.

8.6 References

8.6.1 General

- [8-1] Plantema, F. J.
'Sandwich Construction'
John Wiley & Sons, New York, USA, 1966.
- [8-2] Allen, H. G.
'Analysis and Design of Structural Sandwich Panels', Pergamon Press,
Oxford, UK, 1969.
- [8-3] Stamm, K. and Witte, H.
'Sandwichkonstruktionen' (in German), Springer-Verlag, Wien, Austria,
1974.
- [8-4] Zenkert, D.
'An Introduction to Sandwich Construction: Clause 12: Localised Loads'.
EMAS Publishing, West Midlands, UK, 1995.
- [8-5] 'Structural Materials Handbook', Vol. 1, ESA PSS-03-203, (1994): Clause
26 – Sandwich structures; [See also: ECSS standards]
- [8-6] Frostig, Y. and Baruch, M.
'Bending of Sandwich Beams with Transversely Flexible Core', AIAA
Journal 28, pp. 523-531, 1990.
- [8-7] Frostig, Y.
'On Stress Concentration in the Bending of Sandwich Beams with
Transversely Flexible Core', Composite Structures 24, pp. 161-169,
1993.
- [8-8] Frostig, Y. and Shenhar, Y.
'High-Order Bending of Sandwich Beams with a Transversely Flexible
Core & Unsymmetrical Laminated Composite Skins', Composites
Engineering 5, pp. 405-414, 1995.
- [8-9] Thomsen, O. T.
'Analysis of Sandwich Plates with Through-the-Thickness Inserts Using a
Higher-Order Sandwich Plate Theory', ESA/ESTEC Report EWP-1807,
1994.
- [8-10] Thomsen, O. T.
'Analysis of Sandwich Plates with Fully Potted Inserts Using a Higher-
Order Sandwich Plate Theory', ESA/ESTEC Report EWP-1827, 1995.
- [8-11] W. Hertel, W. Paul and D. Wagner - ERNO Raumfahrttechnik GmbH,
Structures Dept., Bremen, D.
'Standardisation Programme for Design and Testing of Inserts', ESA CR
(P) 1498, ESA Contract No. 3442/77/NL/PP, 1981.

- [8-12] W. Paul and D. Wagner ERNO Raumfahrttechnik GmbH,
Structures Dept., Bremen, D.
'Standardisation Programme for Design and Testing of Inserts, Rider II',
ESA CR (P) 1665, ESA Contract No. 3442/77/NL/PP, 1981.
- [8-13] Saarela, O; Palanterä, M; Häberle, J; Klein, M.
'ESACOMP: A Powerful Tool for the Analysis and Design of Composite
Materials', Proceedings of the International Symposium on Advanced
Materials for Lightweight Structures, ESTEC, Noordwijk, March 1994,
ESA-WPP-070, pp. 161-169.
- [8-14] O.T. Thomsen - CompConsult
Work Order No. 6 - ESTEC Contract No. 10.983/94/NL/PP (1996)
- [8-15] O.T. Thomsen – Aalborg University, DK
Private communication (July 2004)
- [8-16] O.T. Thomsen
'Sandwich Plates with Through-the-Thickness and Fully Potted Inserts:
Evaluation of Differences in Structural Behaviour'
Composite Structures, Vol. 40, No. 2, pp. 159-174. (1998)
- [8-17] O. T. Thomsen & W. Rits
'Analysis and Design of Sandwich Plates with Inserts: A High-Order
Sandwich Plate Theory Approach'
Composites Part B, Vol. 29B, pp. 795-807 (1998)
- [8-18] O.T. Thomsen & W. Rits
'Analysis of Sandwich Panels with Inserts Using a Higher-Order
Sandwich Plate Theory'.
Proceedings of the 10th International Conference on Composite Materials
(ICCM-10, Eds. K. Street and A. Poursartip), Vancouver, Canada, Vol. 5,
pp. 35-42. (1995)
- [8-19] O.T. Thomsen
'Sandwich Plates with Inserts - Modelling, Analysis and Design'
Proceedings of the ESA Conference on Spacecraft Structures, Materials
and Mechanical Testing
ESTEC, Noordwijk, The Netherlands, pp. 619-626 (1996)
- [8-20] O.T. Thomsen
'Load Introduction Aspects in Sandwich Panels with Hard Points'.
Proceedings of the First International Conference on Composite Science
and Technology - ICCST/1 (Eds. A. Adali and V.E. Verijenko), Durban,
South Africa, pp. 539-544 (1996)
- [8-21] O.T. Thomsen
'Higher-Order Effects in Sandwich Plates with Inserts'.

Proceedings of the XIX'th International Congress on Theoretical and Applied Mechanics, Kyoto, Japan (1996)

[8-22] O.T. Thomsen

'Sandwich Plates with Through-the-Thickness or Fully Potted Inserts: Differences in Structural Behaviour and Properties.

European Mechanics Colloquium (EuroMech 360): Mechanics of Sandwich Structures, Saint-Étienne, France, pp. 407-414. (1997)

[8-23] J.Stoer, R. Bulirsh

'An Introduction to Numerical Analysis',

Springer Verlag, New York, 1980.

[8-24] M. Palanterä: Componeering Inc, Finland:

Private communication (June 2004)

8.6.2 ECSS standards

[See: ECSS website: www.ecss.nl]

ECSS-E-HB- 32-20 Structural materials handbook

9

Design aspects

9.1 Design parameters

An insert is part of detachable fixation device. It enables the junction of honeycomb structures, the connection with other structural parts, such as frames, profiles and brackets, as well as the mounting of equipment, e.g. boxes, feed lines and cable ducts.

An insert system consists of a removable and a fixed structural element. The removable part being either a screw or another threaded element. This is attached to the fixed part, the insert and usually connected to the honeycomb by potting compound. A standard insert system is composed of three components, [See also: Clause 5; A.3; F.6 for non-standard insert systems]:

- Insert,
- Sandwich structure,
- Potting compound, or equivalent.

Designers deciding to use inserts face a large number of options and non-standardised parameters to consider that relate to:

- Geometry;
- Material;
- Loads;
- Failure modes;
- Special conditions.
- Table 9-1 summarises the basic insert design parameters.



Table 9-1: Summary of the basic insert design parameters

GEOMETRY	MATERIAL	LOADS	FAILURE MODE	SPECIAL CONDITIONS
Face sheet thickness	Face sheet	Mechanical loads	Strength and stability	Reliability
	<ul style="list-style-type: none"> ▪ aluminium ▪ GFRP ▪ CFRP 	<ul style="list-style-type: none"> ▪ Short term and long term 		<ul style="list-style-type: none"> ▪ design ▪ manufacture ▪ control ▪ testing
Core	Core	Static loads	Life and residual strength	
<ul style="list-style-type: none"> ▪ height ▪ cell size ▪ foil thickness ▪ perforated 	<ul style="list-style-type: none"> ▪ foam ▪ honeycomb: Al 5052 Al 5056 GFRP Nomex® 	<ul style="list-style-type: none"> ▪ tensile ▪ shear: + symmetric + antisymmetric ▪ torsion ▪ bending moment ▪ magnitude of load ▪ direction of load 		
Insert	Insert	Dynamic loads	Failure of core	
<ul style="list-style-type: none"> ▪ diameter ▪ height 	<ul style="list-style-type: none"> ▪ aluminium ▪ steel ▪ titanium 	<ul style="list-style-type: none"> ▪ shock ▪ vibration ▪ quasistatic ▪ cyclic 	<ul style="list-style-type: none"> ▪ shear ▪ normal ▪ buckling 	
Potting	Potting	Conditions	Failure of face sheets	
<ul style="list-style-type: none"> ▪ diameter ▪ height ▪ configuration 	<ul style="list-style-type: none"> ▪ Classical: glass bubble + epoxy ▪ Other, [See: A.3; F.6 	<ul style="list-style-type: none"> ▪ amplitude ▪ exceedances ▪ sequence ▪ direction 	<ul style="list-style-type: none"> ▪ tensile ▪ shear out ▪ dimpling ▪ bearing 	
Insert-to-edge distance		Preload	Failure of insert	
		<ul style="list-style-type: none"> ▪ thermal environment ▪ mounting stress 	<ul style="list-style-type: none"> ▪ fracture on insert flange ▪ fracture on thread or screw 	
Insert-to-insert distance		Thermal	Failure of potting	
<ul style="list-style-type: none"> ▪ same normal load ▪ opposite normal load 		<ul style="list-style-type: none"> ▪ quasistatic ▪ dynamic 	<ul style="list-style-type: none"> ▪ resin fracture on basic plane ▪ shear fracture on cylinder 	
		Physical load		
		<ul style="list-style-type: none"> ▪ radiation ▪ vacuum ▪ humidity 		

There is no standardised method to handle joints realised by inserts. In general, some of the parameters are already available, e.g. global stiffness, thermal- or moisture stability or functionality aspects.

An insert joint is designed for the existing structure. However, a designer has a possibility to make local changes to the global structure to obtain a better joint using an insert.

Figure 9-1 illustrates the various design alternatives and parameters.

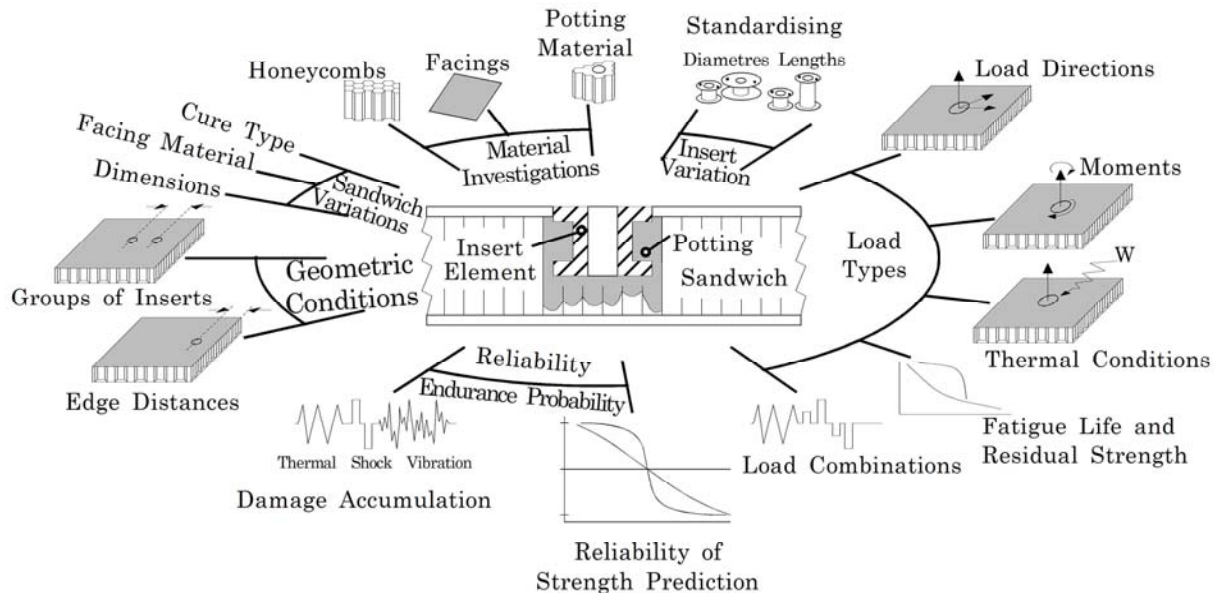

Figure 9-1: Basic aspects of insert design, analysis and testing

9.1.1 Metal face sheets

Inserts in honeycomb sandwich panels with metallic face sheets are commonly designed taking into account two independent aspects:

- The panel parameters are selected based on the global requirements, e.g. global load carrying capability, a minimum stiffness, thermal stability, mass optimisation, human factors (in manned modules/spacecraft for example, the face sheet should be thick enough to avoid damage coming from on-board human activities).
- The insert design is then performed quite independently by selecting the number of inserts and their dimensions able to carry the required loads following the design guidelines and data within this handbook.

[See also: 11.1]

9.1.2 Composite face sheets

For CFRP-face sheets it needs to be recognised that the number of parameters is far higher than for the common metal face sheet, e.g. aluminium alloy, where the face sheet thickness is the only parameter.

There are many options of fibre-types, ply thickness, fibre orientation, number of plies and different laminate stacking sequences to be considered for composite face sheets. By definition, the selection of an insert design for CFRP sandwich panels cannot be as simple as for panels having far less anisotropic metal face sheets, [See also: ECSS-E-HB-32-20].

A further consequence of sandwich panel with CFRP face sheets relates to the design procedure. It is not possible to select inserts independently of the panel design. The panel global capability is significantly influenced by the hole cut to incorporate the insert. In parallel are the insert load-carrying capabilities under in-plane loading which are reduced by the global membrane stress applied to the panel face sheet.

Consequently the designer is confronted with the interaction of global and local requirements.

9.2 Main load directions

An insert can carry out-of-plane, in-plane, moment and torsion loads both in static and dynamic cases, as shown in Figure 9-2.

In addition, the geometrical dimensions and environment conditions, e.g. thermal, moisture, radiation and vacuum, should all be considered

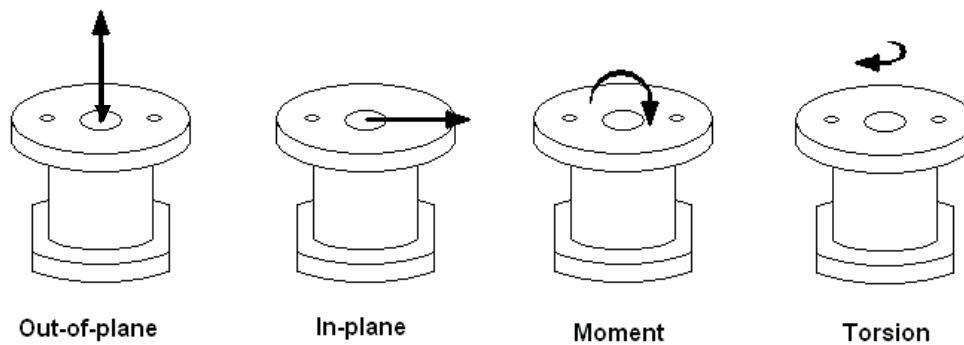

Figure 9-2: Insert load cases

9.2.1 Out-of-plane load

An out-of-plane load can be either tension or compression. It is good design practise to carry the bending moments by the out-of-plane force on pairs of inserts, as shown in Figure 9-3.

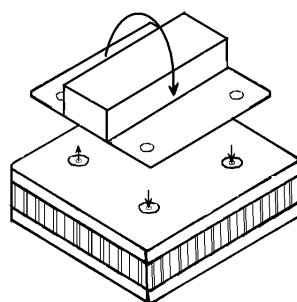

Figure 9-3: Insert out-of-plane load

9.2.2 In-plane load

An in-plane load can be either tension or compression. A good design practise is that torsional loads are carried by in-plane loads on several inserts; as shown in Figure 9-4.

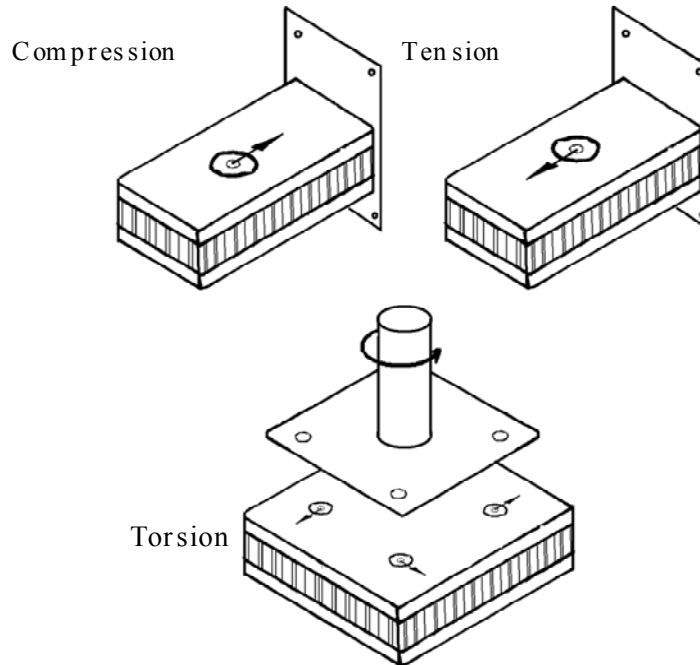

Figure 9-4: Insert in-plane load

9.3 References

9.3.1 General

- [9-1] L. Sylvänen et al : Patria Finaviacomp Oy, Finland
 ‘Analysis models for insert design rules in sandwich panels with CFRP facings’
 Patria report: GS1-PFC-RP-0002 (January 2003)
 ESTEC Contract No. 14076/99

9.3.2 ECSS standards

- [See: ECSS website: www.ecss.nl]
 ECSS-Q-70-series Space product assurance
 ECSS-E-30-series Space engineering - Mechanical
 ECSS-E-HB-32-20 Structural materials handbook
 ECSS-E-HB-32-21 Adhesive bonding handbook

10

Design considerations

10.1 Insert arrangement

Design constraints govern the way in which inserts are incorporated into a sandwich structure.

Figure 10-1 shows several of examples of insert arrangements.

NOTE Inserts with a lateral axis have very low load-carrying capabilities, so are avoided, [See: Figure 10-1 – C].

A		Single insert without edge influence [See: 12.1]
B		Single insert near edges [See: 18.1; 18.2]
C		Insert axis parallel to facings
D		Adjacent inserts axially loaded in the same direction [See: 19.1]
E		Adjacent inserts axially loaded in opposite directions [See: 19.2]
F		Adjacent inserts in line (profile junction arrangement) [See: 19.3]
G		Adjacent inserts in group (bracket junction arrangement) [See: 19.5]

Figure 10-1: Typical insert arrangements Load capability

Various insert arrangements are described in more detail:

- Case A: Single insert without edge influences, [See: 12.1].

- Case B: Single insert near edge, [See: 17.1; 17.2]
- Case C: Insert axis parallel to face sheets.
NOTE To be avoided due to the very low load-carrying capability.
- Case D: Adjacent inserts axial-loading (same direction), [See: 19.1].
- Case E: Adjacent inserts axial-loading (opposite direction), [See: 19.2].
- Case F: Adjacent inserts in line (profile junction), [See: 19.1].
- Case G: Adjacent inserts in group (bracket junction), [See: 19.1].

10.2 Load conditions

10.2.1 General

An insert transfers five basic types of load, which can act singly or combined. These are:

- Tensile, where the load is normal to the plane of the sandwich away from the surface, [See: 12.1];
NOTE Also known as 'pull-out'.
- Compressive, where the load is normal to the plane of the sandwich towards the surface, [See: 13.1];
- Shear, where the load is in the plane of the face sheet, [See: 14.1];
- Bending, [See: 15.1];
NOTE Also known as 'rotation'.
- Torsion, [See: 16.1].
NOTE Also known as 'torque-out'.

The load conditions are summarised in Figure 10-2.

Load capability

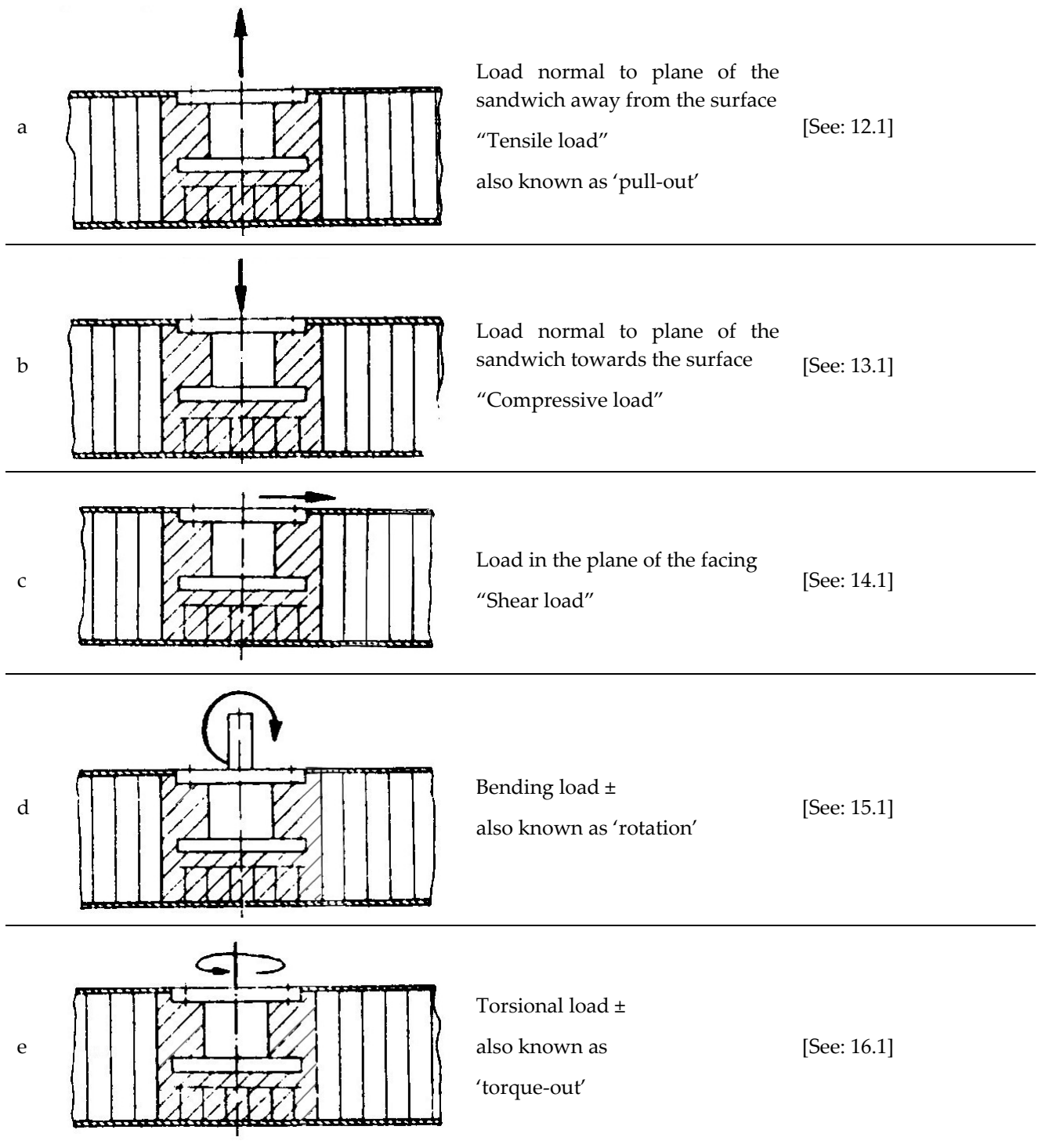

Figure 10-2: Insert load conditions

10.2.1.1 Tensile, compression and shear

A design gives preference to loadings in the insert axis or transverse to it, i.e. tensile, compressive or shear-loading; [See: Figure 10-2 - a, b and c].

When a load acts in a direction that forms an acute angle with the insert axis, this load can be resolved into two rectangularly-acting components, thus producing tension and shear or compression and shear.

10.2.1.2 Bending

Bending loads should be avoided because of the low bending strength and stiffness of an insert system.

10.2.1.3 Torsion

Torsional loads on single inserts are restricted to screwing and locking torques only.

[See also: 10.6 for general guidance on insert selection]

10.2.2 Design guide

10.2.2.1 Metallic face sheets

For sandwich panels with metal face sheets, an insert is usually loaded via a cleat, bracket or a washer having a footprint size larger than the potting dimension. The pre-load of the screw connecting the bracket to the insert is selected to be sufficiently high in order to prevent gapping, [10-1].

Figure 10-3 shows some examples that are in line with the general design rules.

a		<p>Contact area greater than potted area</p>
b		<p>Contact area smaller than the insert flange area</p> <p>incorrect design</p>
c		<p>Shimming plate smaller than the potted area</p> <p>incorrect design</p>

Figure 10-3: Sandwich panel with metallic face sheets: General design rules

The general design rules ensure that, [10-1]:

- Compressive loads are transmitted via the face sheet in the area of the potting. The bracket or foot needs to have at least the maximum extension of the potting; [See: Figure 10-3 – a].
- The insert flange remains parallel to the face sheet such that under in-plane loads it cannot move below the face sheet; shown in Figure 10-4 – b.
- Loads in plane of the face sheet are usually transmitted by bearing pressure between the outer insert flange and the face sheet; shown in Figure 10-4 – a.
- The border of the face sheet around the insert is well supported to accommodate a high bearing stress, created inside by the potting and outside by the bracket or foot.
- Under a sufficient pre-load of the insert bolt minor or secondary bending moments are correctly reacted; as shown in Figure 10-5 – a.
- Major moments in plane of face sheets are introduced by a couple of inserts. Moment introduction to an insert, as shown in Figure 10-4 – b, should be avoided.

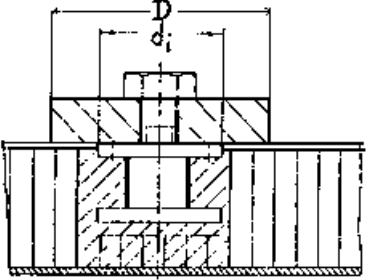
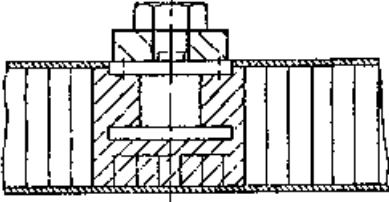
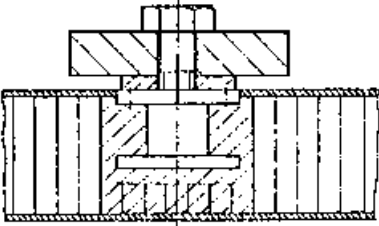
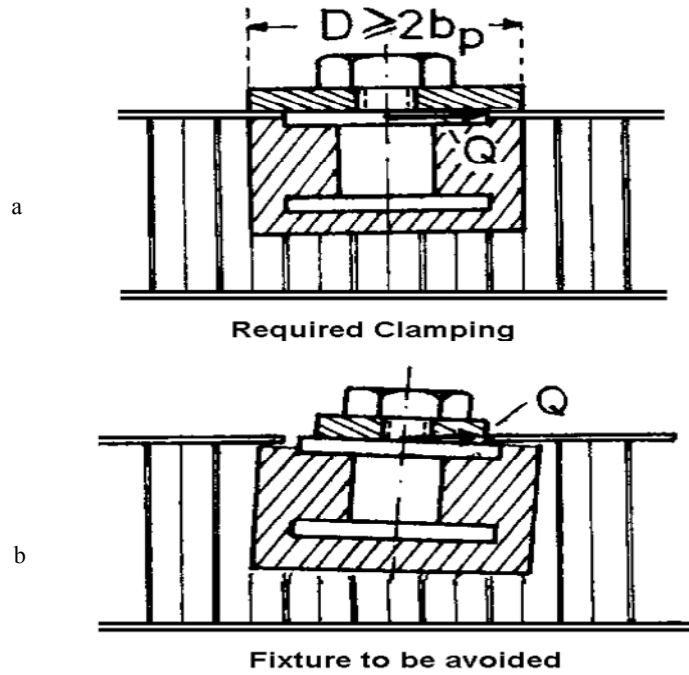

Figure 10-4: Insert design under in-plane load

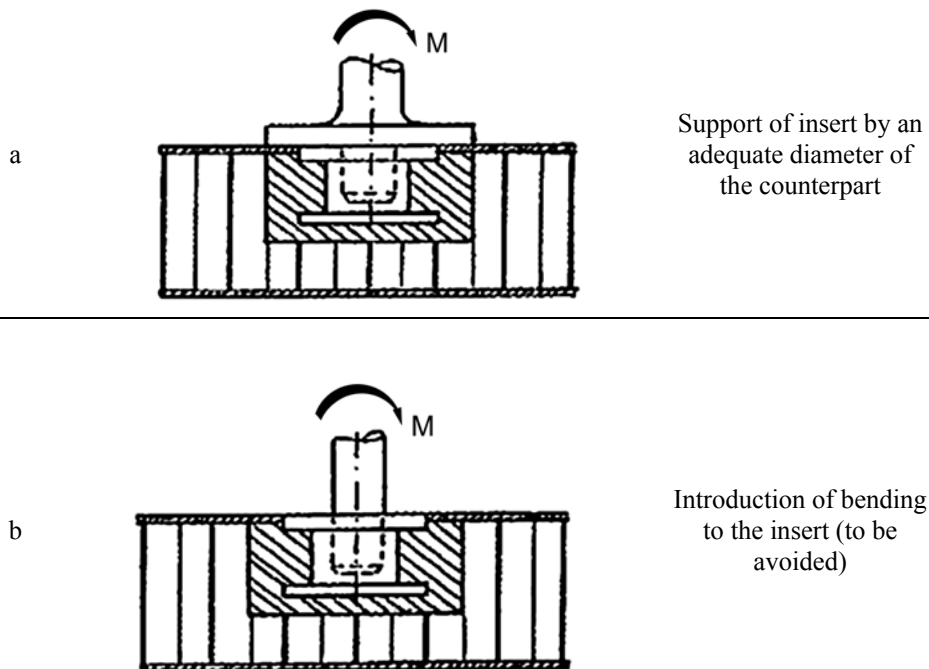

Figure 10-5: Insert design loaded by moments

For metallic face sheets, the inserts are installed such that their flanges are flush, i.e. in plane with the outer plane of the face sheet in order to maintain the advantages summarised by the design; [See: 10.2.2 Design guide for metallic face sheets]. The tolerance of installation is such that the flange can be below the outer plane of face sheet by 0.03 mm but never exceeding the face sheet, i.e. protruding inserts should be avoided, [10-1].

An insert potted in accordance with this tolerance does not lose a significant part of its pre-load when it is exposed to elevated temperature.

If an insert flange is protruding slightly out of the face sheet due to inadequate manufacturing tolerances, it can be machined so that it becomes flush. This practice is sometimes applied successfully with aluminium face sheet.

10.2.2.2 CFRP face sheets

For a sandwich panel with thin CFRP face sheets, machining can be seen as problematical, although a thorough finishing of the protruding parts of the inserts is considered necessary in order to avoid damaging the surface ply. The machining process needs to be carefully investigated and reflected in the definition of the manufacturing procedure, [10-1].

For thin face sheets made of CFRP with a flush mounted insert, another problem needs to be avoided under loads in-plane in the face sheet. If the outer insert flange has even a small chamfer, possibly non-intentional, the load transfer is reduced by bearing stress. The insert tends to undercut the face sheet; as shown in Figure 10-6, [10-1].

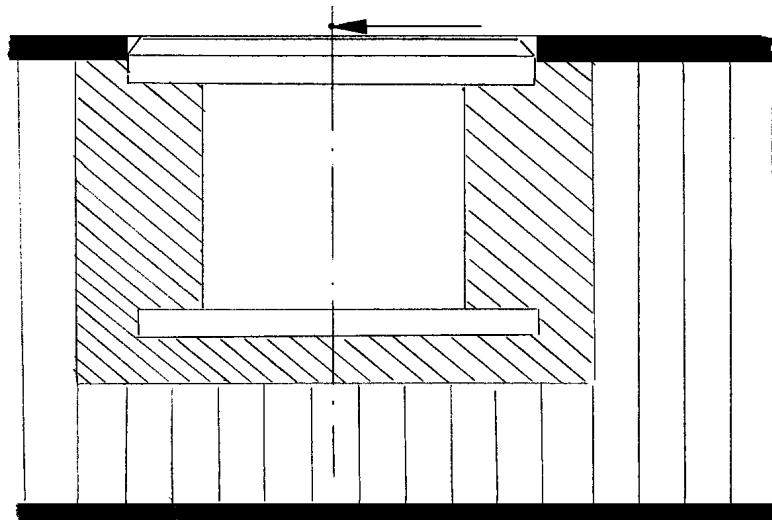

Figure 10-6: CFRP face sheets: Effect of small chamfer on insert flange on load transfer to face sheet

10.3 Mounting modes

10.3.1 General

Positioning of inserts with respect to the surface of the sandwich panel depends upon mounting needs, [See also: 10.6 for selection of inserts; 10.2 for load conditions].

10.3.2 Flush-mounted insert

Generally, a flush-mounted insert is necessary, i.e. the upper surface of the insert is level, or flush, with the face-sheet surface; as shown in Figure 10-7 – A.

10.3.3 Recessed insert

It is practically impossible to set an insert accurately in the flush-mounted position, i.e. $x = 0$, so a small negative tolerance of up to 0.03 mm is acceptable, [See: Figure 10-7 – B]. This is the normal mode of mounting and it also ensures:

- Good heat transfer from mounted electronic boxes (or other heat-developing equipment) into the face sheet, and
- Minimises secondary bending effects.

In cases where the foot of the equipment is larger than the insert diameter, when the tightening torque is applied to the bolt, the insert tends to be extracted from the panel by a 'corkscrew' effect. Additional stresses are also created at the panel-to-insert interface, [See also: Protruding insert].

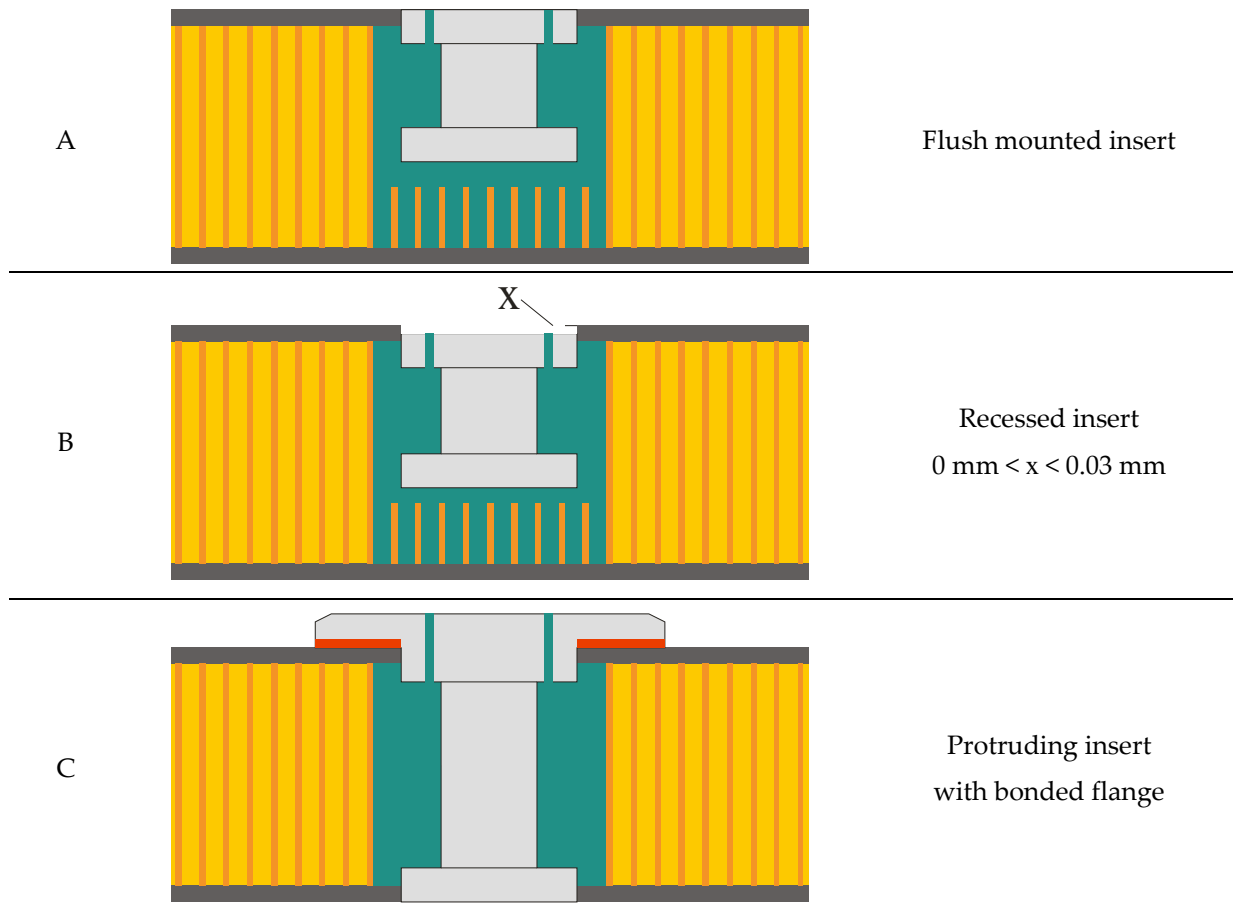

Figure 10-7: Insert mounting modes

10.3.4 Protruding insert

An insert can be positioned such that the flange(s) protrudes beyond the sandwich panel surface. This is also known as 'proud' or 'over flush'. This positioning is used to, [10-1]:

- guarantee a well-defined contact area between the assembled parts, so controlling the load-transfer path;
- limit the contact between mounted equipment and the sandwich panel, e.g. for thermal reasons;
- enables flatness over a group of inserts.
- avoids additional stresses and 'corkscrew' effect seen with recessed inserts when the equipment foot is larger than the insert diameter, [See: Recessed insert].

The limited thermal contact area can be a problem when the foot of the equipment is larger than the insert diameter. If a full thermal contact area is needed, a filler with a hole the same diameter as the insert flange can be placed between the foot and the panel.

10.3.5 Bonded flange

A protruding insert can have a circular flange end that is adhesively bonded to the external surface of the sandwich face sheet, [See: Figure 10-7 – C]. The flange enables [10-2]:

- Improved in-plane shear capability;
- Increased contact area and inertia, so improved stress distribution between two assembled structures;
- Improved mechanical performance, e.g. shear, pull-out, torque and bending (rotation).

NOTE Sandwich panels with metal face sheets exhibit higher properties, where failure occurs in the bonding, than those with composite face sheets, where the failure occurs in the first CFRP ply.

- Machining of the flange surface to improve the stress distribution with the equipment foot, e.g. individual flatness and between groups, friction.
- Close tolerances on drilling.

This type of insert is increasingly used for structural load-introduction points in metallic and composite sandwich panels in space, e.g. SPOT 5, [See also: F.7].

The main disadvantages of inserts with bonded flanges are the increased mass and manufacturing costs, along with difficulties in repairing any which are misplaced or poorly installed, [10-2].

10.4 Junction of components

10.4.1 General

To achieve a satisfactory junction of components, the brackets should exhibit a sufficiently large contact area at the connecting point.

10.4.2 Minimum value

The minimum dimension D , shown in Figure 10-8 – Mode a, is equal to the potting diameter, which is approximately the insert diameter, d_i , plus 8 mm, [See: Figure 7-2]

NOTE In Figure 10-8, Modes b and c should be avoided.

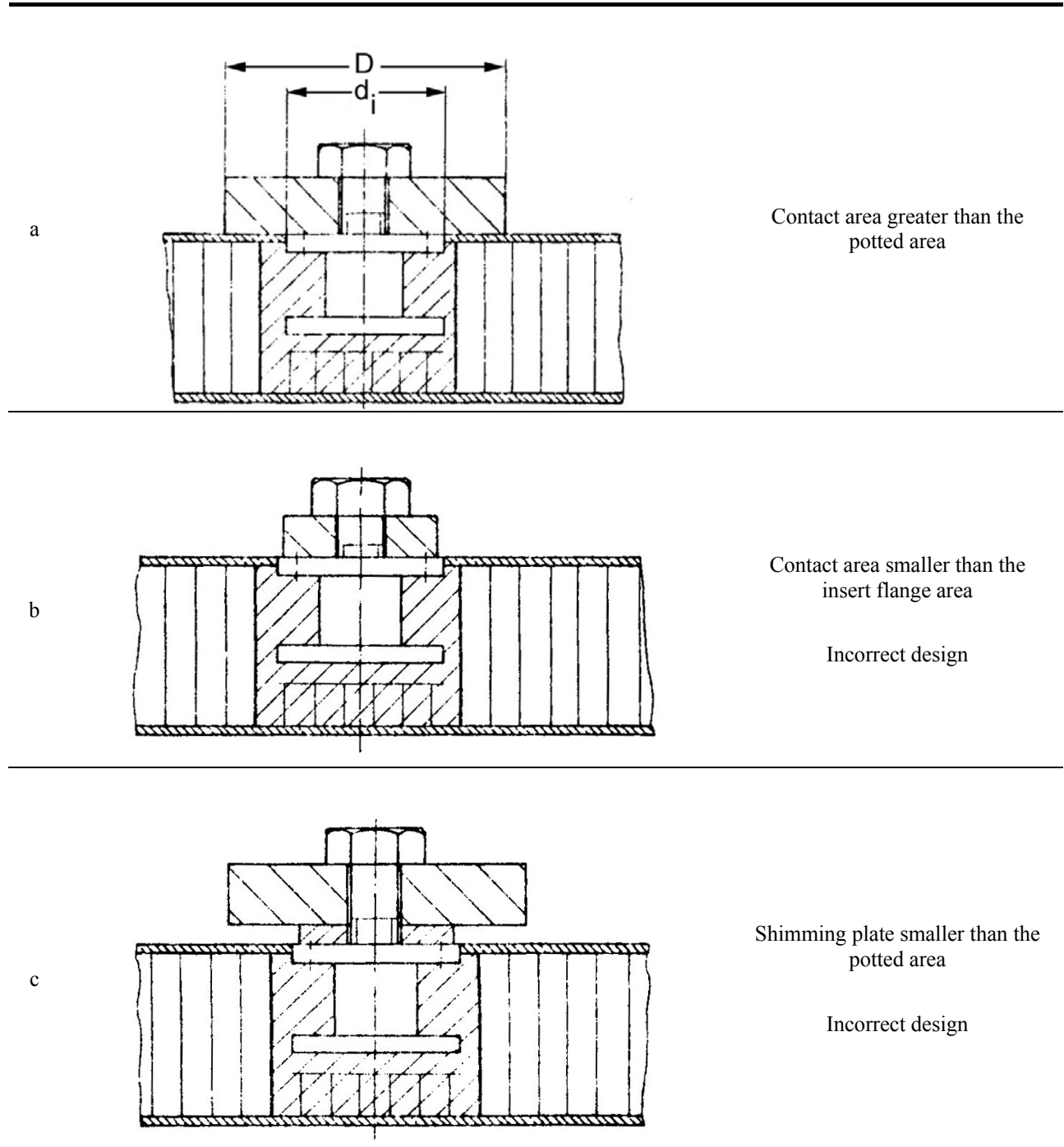

Figure 10-8: Connections

10.5 Adequate insert design

10.5.1 Insert arrangement

A selection procedure for the most appropriate insert arrangement is not presented in this handbook. This remains the province of creative designers whose aim includes optimising the:

- Inserts with respect to sandwich configuration;
- Number of inserts;
- Their pattern;
- Added mass;
- Related manufacturing problems;
- Quality assurance provisions.

Within the constraints provided here, designers select the insert configuration that meets a set of prioritised demands.

[See also: Clause 11]

10.5.2 Typical spacecraft design

Within this handbook detailed information is provided on all aspects of typical spacecraft design, especially the:

- Standardisation of insert geometries and materials, [See: 4.1];
- Sandwich panel characterisation, [See: 6.1; 8.1];
- Potting geometry, [See: 7.1];
- Potting process, [See: 23.3; 25.1];
- Static strength of inserts:
 - tensile, [See: 12.1];
 - compressive, [See: 13.1];
 - shear, [See: 14.1];
 - bending, [See: 15.1];
 - torsion, [See: 16.1];
 - stiffness, [See: 20.1]
- Fatigue life of inserts, [See: 21.1];
- Manufacturing procedures, [See: 23.1];
- Test procedures, [See: 27.1; 29.1; H.1 for test fixtures];
- Quality assurance, [26.1; 27.1; 28.1].

NOTE The information is presented in a format that is easily accessible to designers, without the need for extensive analytical work.

10.5.3 Examples

Some examples of the use of inserts in space applications are provided from:

- IATP 'insert allowable test programme', [See: E.1];
- Case studies of some European projects, [See: F.1];
- Jigs and fixtures appropriate for testing inserts, [See: H.1].

10.6 Selection of inserts

10.6.1 General

The terms used to describe the standard forms of inserts varies across the industry, [See also: Table 5-1; Figure 8-7]. e.g.:

- Partially potted, also known as blind, 'borne' or single-sided.
- Fully potted, also known as blind or 'borne'.
- Through-the-thickness, also known as transverse or double-sided.

Non-standard forms of inserts can be variations or combinations of the standard types, [See: A.3].

10.6.1.1 Partially potted

These are used where the loads to be transferred, per fixing point, are limited to in-plane and transverse forces. This is often the case where the item to be attached to the sandwich panel has a number of fixing points joined by a stiff structural part, e.g. the majority of electronic equipment; feet of ASAP4 struts.

A global bending moment is resolved to 'pure' forces at each fixing point; as shown in Figure 10-9.

Partially potted inserts also provide mass-saving compared with fully potted inserts, [10-1].

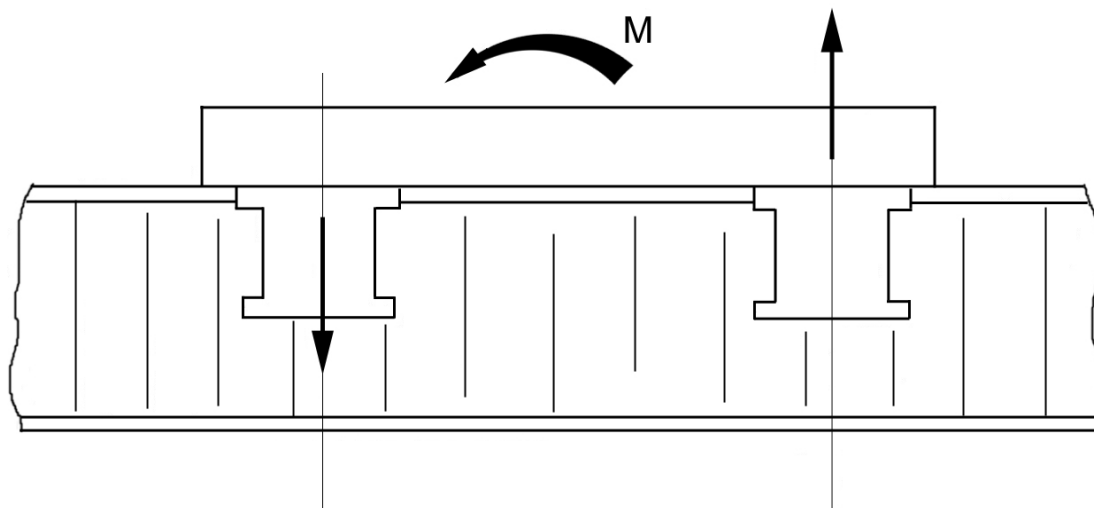

Fig

re 10-9: Selection of inserts: Partially potted

10.6.1.2 Fully potted

Some types of partially potted inserts can be fully potted, [See: Table 5-1]. In general, their static load-bearing capability is better than partially potted inserts, but inferior to through-the-thickness types, [See also: 8.4].

10.6.1.3 Through-the-thickness

These are used when local bending moments are applied to single inserts. This enables the bending to be transferred directly to the sandwich panel face sheets, as shown in Figure 10-10. These forces are then countered by the in-plane forces in each face sheet.

Through-the-thickness inserts are also used where a bolted connection to each side of the sandwich panel is necessary, e.g. ASAP5, [10-1]

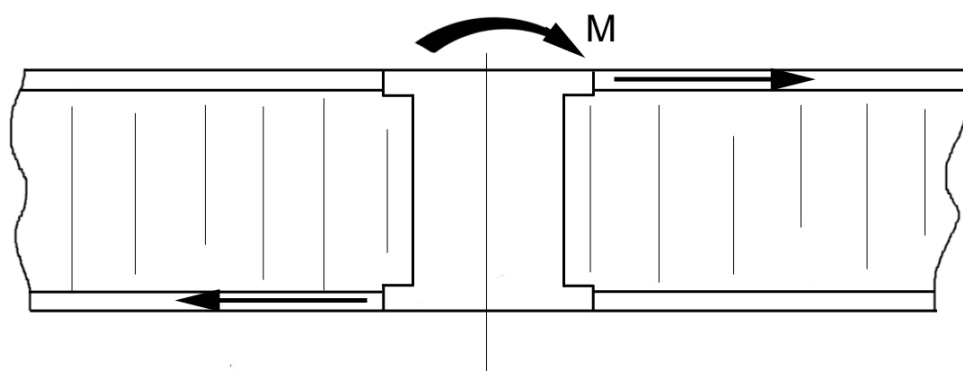

Figure 10-10: Selection of inserts: Through-the-thickness

10.6.2 Sufficient static strength

The static strength of an insert is considered successfully verified if its load-carrying capability is greater than the design loads, i.e. limit loads, multiplied by a safety factor, j :

$$P_{\text{allowable}} \geq P_{\text{ult}} = P_{\text{limit}} \times J_n \quad [10.6-1]$$

10.6.3 Safety factor

If not defined in a program specification, a safety factor, j of 1.5 is applied to avoid failure, [See also: 12.4].

10.6.3.1 Example

The mechanical parts of the EM ATV Cargo Carrier considered additional safety factors (SF_{add}), which were applied to, [10-2]:

- Bonding, structural inserts (axial): Ultimate:
 - Tested: 1.0
 - Not tested: 1.2
- Equipment inserts in honeycomb: Ultimate:
 - Tested: 1.1
 - Not tested: 3.0

Where:

$$F_y = F_{\text{lim}} \times SF_{add} \times J_E \quad [10.6-2]$$

$$F_u = F_{\text{lim}} \times SF_{add} \times J_R \quad [10.6-3]$$

10.7 Minimum and average insert capability

10.7.1 Minimum

The minimum insert capabilities $P_{SS \text{ min}}$, [See also: 12.5] are related to the minimum values of:

- potting geometry: $b_p \text{ min}$, $h_p \text{ min}$
- core strength of metallic cores:

$\tau_{c \text{ crit min}}$; $\sigma_{c \text{ crit t min}}$; $\sigma_{c \text{ crit c min}}$

- core strength of non-metallic cores:

$\tau_{c \text{ crit guar}}$; $\sigma_{c \text{ crit t guar}}$; $\sigma_{c \text{ crit c guar}}$

10.7.1.1 Permissible minimum values

The $P_{SS \text{ min}}$ values are applicable without further investigations, provided that the:

- core properties are in accordance with:
 - MIL-C-7438;
 - national procurement specifications.
- manufacturing is in accordance with:

- manufacturing specification, [See: 23.1; 24.1; 25.1];
- quality assurance specification, [See: 26.1; 27.1; 28.1].

If the minimum material data and potting dimension apply, the probability of exceeding the given minimum load capability is 99% with a confidence level of 95%.

10.7.2 Average

The average insert capabilities $P_{SS\ av}$ [See: 12.7; Annex B], are related to the average or typical values, respectively, of:

- Potting geometry: $b_{p\ typ}, h_{p\ typ}$
- Aluminium core strength:
- $\tau_{c\ crit\ av}, \sigma_{c\ crit\ t\ av}, \sigma_{c\ crit\ c\ av}$
- Non-metallic core strength:

$\tau_{c\ crit\ typ}, \sigma_{c\ crit\ t\ typ}, \sigma_{c\ crit\ c\ typ}$

10.7.2.1 Permissible average values

Seventy percent of the average capability values are applicable without further investigation provided that the:

- Core properties meet, at least, the typical or average values given in Table 6-3;
- Manufacturing meets the:
 - manufacturing specification, [See: 23.1; 24.1; 25.1]
 - quality assurance specification, [See: 26.1; 27.1; 28.1]
- Load-transfer is maintained by:
 - a set of inserts close together with different loads;
 - the potential of redistribution.

NOTE Under these circumstances, a reduced factor of safety can be justified, [See also: 9.04].

10.8 Pre-design

The design methods detailed within this handbook have been successfully applied to numerous applications. Some different or simplified hypotheses that have been suggested for pre-design are summarised here. All information presented is taken from [10-1].

NOTE 1 Whatever the analysis method used to determine insert capability, validation tests are necessary for critical cases, i.e. where safety margins obtained by analysis are too low.

NOTE 2 Guaranteed load-capability values are:

- highly dependant on manufacturing processes and their control;
- reliant upon adequate quality assurance procedures.

10.8.1 Load path for in-plane forces

10.8.1.1 General

It has been considered, and confirmed by examination of the rupture mode, that this type of load is transferred by bearing in the face sheet. The allowable force is then given by:

$$F_{\text{all}} = \sigma_{\text{bearingall}} \times t \times \phi \quad [10.8-1]$$

Where:

$\sigma_{\text{bearing all}}$	allowable bearing stress of face sheet material;
t	thickness of contact area between insert and face sheet;
ϕ	diameter of contact area between insert and face sheet.

10.8.1.2 Through-the-thickness insert

For a through-the-thickness insert subjected to a bending moment, it can be assumed that the moment is taken by bearing of both face sheets. The insert is then considered as a simply-supported beam, as shown in Figure 10-11.

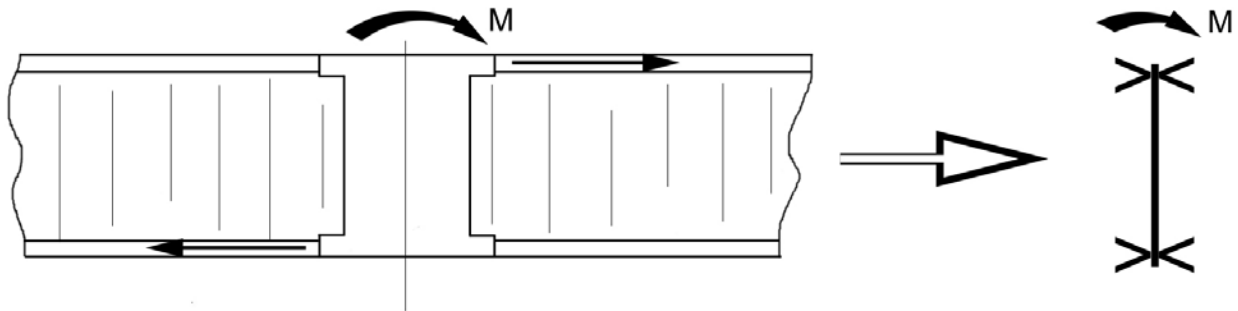

Figure 10-11: Pre-design: Through-the-thickness insert under bending

This analysis approach correlates well with test results, but it assumes that the insert and bore hole are of the correct dimensions, i.e. the bore hole is machined precisely for the insert used. If the bore hole is too large, then the allowable force is severely reduced.

[See also: 23.10 for defects]

10.8.1.3 Inserts with an upper flange

Bonding of the flange to the sandwich panel skin increases the shear load capability, by:

$$F_{\text{add}} = \tau_{\text{all}} \times S_{\text{bonding}} \quad [10.8-2]$$

where:

- τ_{all} allowable shear stress of bonding, e.g. 10 MPa, typically;
- S_{bonding} area of bonding.

10.8.1.4 Inserts near an edge

A face sheet 'shear-out' failure mode can occur where inserts (flanged or not) are positioned close to the edge of a panel, as shown in Figure 10-12.

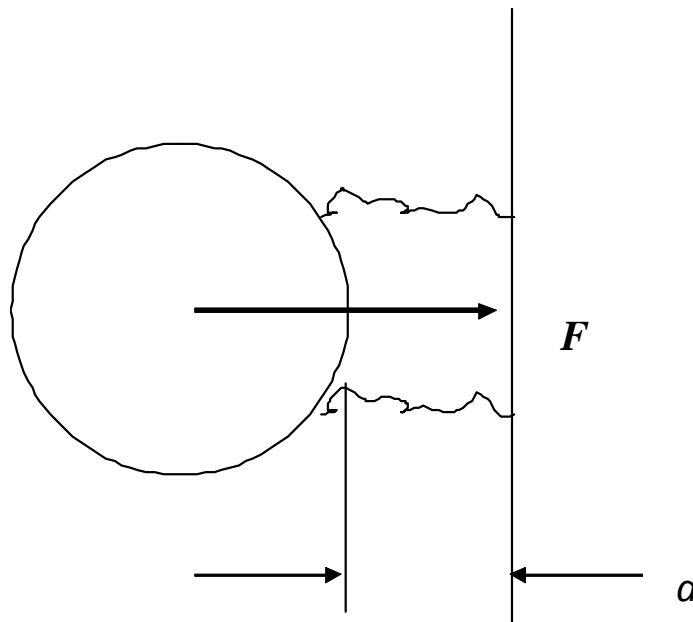

Figure 10-12: Pre-design: Face sheet shear-out failure mode

The load capacity can be determined by:

$$F_{all} = 2 \times d \times t \times \tau_{all} \quad [10.8-3]$$

where:

- d distance from the panel edge;
- t face sheet thickness;
- τ_{all} allowable shear stress of face sheet material.

10.8.2 Load path for transverse forces

The strength when submitted to transverse force can be assumed to be limited to the shear buckling of the honeycomb core at the core-to-potting interface. This applies to:

- through-the-thickness inserts;
- partially potted inserts, where the insert height is large compared with the core height.

The allowable tension or compression force is given by:

$$F_{all} = \tau_{all} \times h \times \pi D \quad [10.8-4]$$

- where:
- D diameter of potting, [See: Figure 10-13].
 - h core height;
 - τ_{all} allowable shear strength of honeycomb.

NOTE 1 For partially potted inserts with a low height compared with the core height, the calculation is not valid.

NOTE 2 A pessimistic assessment can be obtained by substituting the height of the insert for the core height (h) in Eqn. [10.8-4].

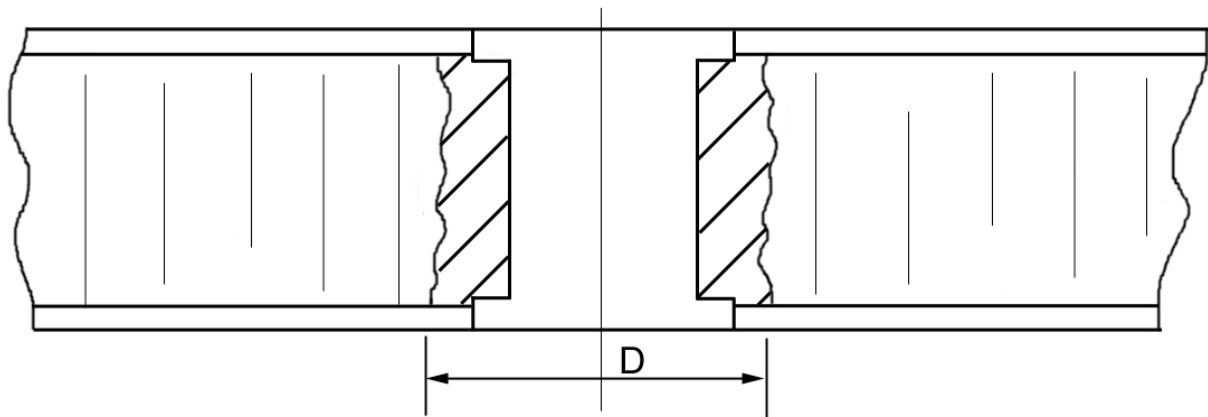

Figure 10-13: Pre-design: Through-the-thickness insert under transverse force

10.8.3 Transverse and in-plane load interaction

Given the assumptions made for each load case, loads are transmitted to different load-bearing components, i.e.:

- In-plane loads are transmitted to face sheets;
- Transverse loads are transmitted to the honeycomb core.

Therefore, any interaction can be considered negligible for pre-design calculations.

10.8.4 Proximity and edge effects

Using the design method detailed in this handbook produces reduction factors that are known to be very conservative compared with test results.

10.9 Failure modes

10.9.1 General

Failure can occur in the sandwich structure with inserts in many different ways and depends on, e.g.:

- Design parameters;
- Load cases;
- Conditions;
- Manufacturing.

Generally, the failure occurs in the core by shear stresses under out-of-plane loads and in the face sheet under in-plane loads, [10-1].

Failure modes are listed in Table 10-1. Failure occurring in the insert, fasteners and other attachable devices is not considered.

Table 10-1: Failure modes of insert joint

Failure component	Failure type	Load case ⁽¹⁾
Core	Shear failure	Out-of-plane (T, C)
	Tension failure underneath potting	Out-of-plane (T)
	Compression failure underneath potting	Out-of-plane (C)
Potting	Tensile failure underneath insert	Out-of-plane (T)
	Insert tear out	Out-of-plane (T)
Adhesion	Adhesion failure between insert and potting	Out-of-plane (T)
	Adhesion failure between core and face sheet	Out-of-plane (T)
Face sheet	Tension failure	In-plane
	Bearing failure	In-plane
	Dimpling failure	In-plane
	Wrinkling failure	In-plane
	Shear-out failure	In-plane
Insert	Lower flange, thread, fastener, screw...	Not considered

Key: T = Tension; C = Compression

10.9.2 Failures under out-of-plane loads

10.9.2.1 General

An out-of-plane load can be either tension or compression. It is good design practise to carry the bending moments by the out-of-plane force on pairs of inserts, as shown in Figure 10-14, [10-1].

The load is transferred through the insert-sandwich system as shown in Figure 10-15.

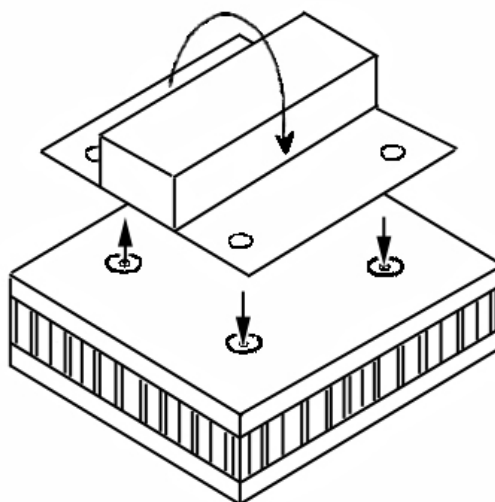

Figure 10-14: Failure modes: Moment load

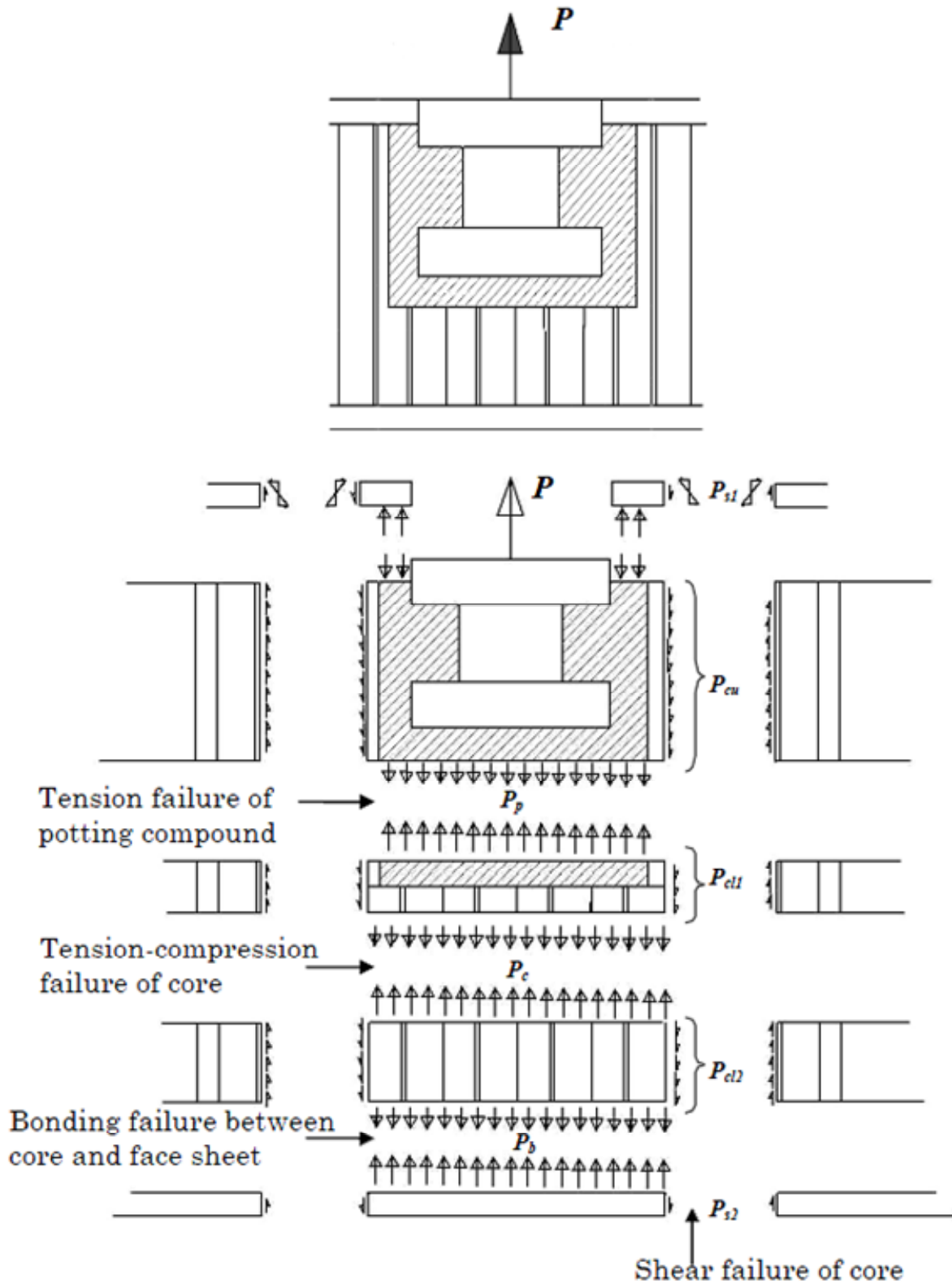

Figure 10-15: Failure modes: Load transfer in out-of-plane case

10.9.2.2 Study of several cases

10.9.2.2.1 Overview

The several cases are shown in Figure 10-16 and explained in the clauses 10.9.2.2.2 to 10.9.2.2.5.

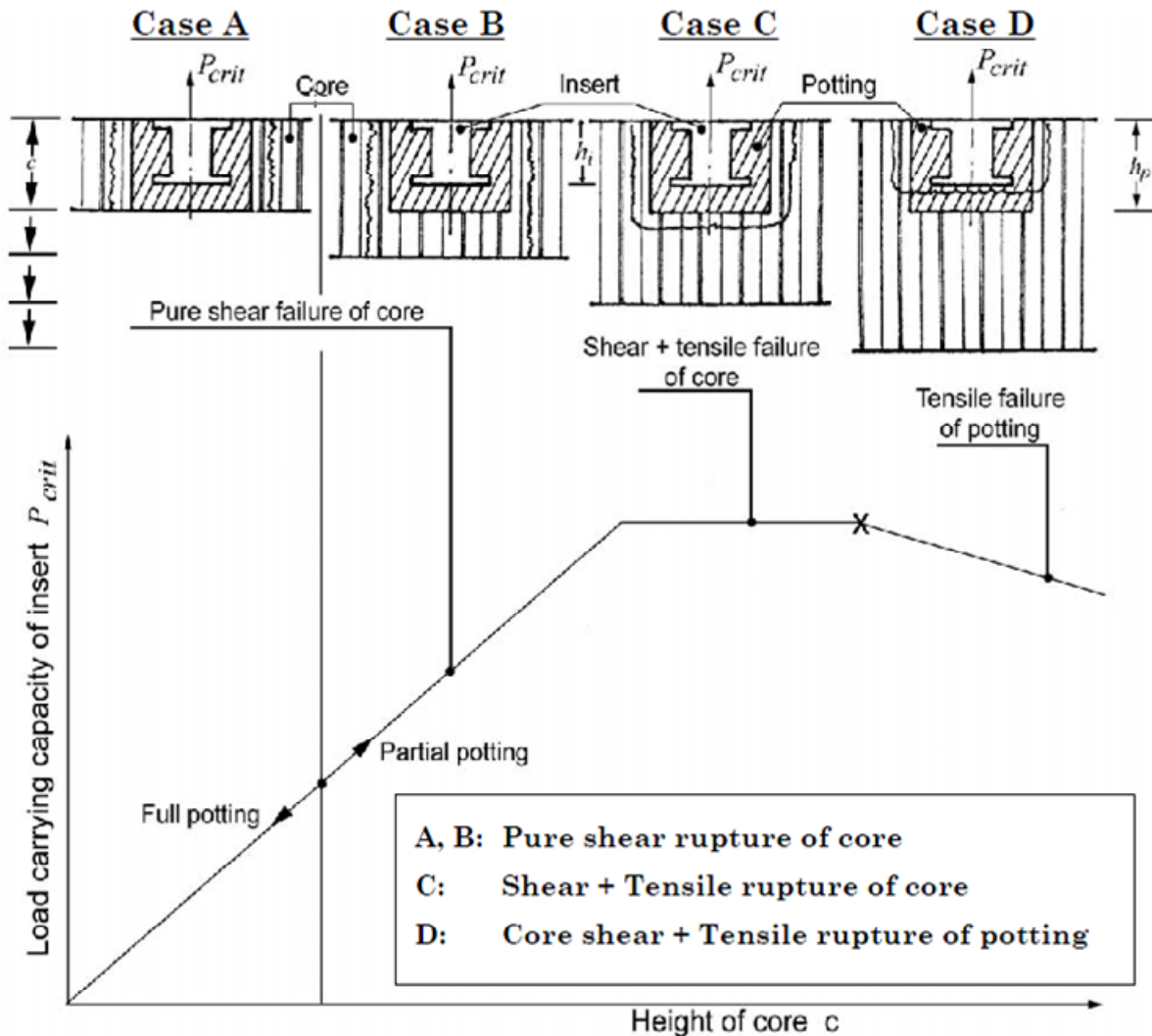

Figure 10-16: Failure modes: Insert as a function of core height

10.9.2.2.2 Case A - fully potted or through-the-thickness

Under out-of-plane tension load rupture occurs, in general, in the core by shear (tension load is carried by core shear).

10.9.2.2.3 Case B - partially potted, thin core

In the case of low core heights, a partially potted insert acts like a fully potted insert (Case A). The load carrying capability of the core in shear is weaker than the load carrying capability of the core or the potting in tension.

10.9.2.2.4 Case C - partially potted

The cross-section area of the single cell foils under shear stress depends on the core height. When the cross-section area is large enough, the load carrying capability of the core in shear exceeds the load carrying capability of the core in tension and the rupture occurs in the core underneath the potting.

10.9.2.2.5 Case D - partially potted

The situation is similar to that of case C, but the load-carrying capability of the potting compound in tension is weaker than the core. Depending on the combination of the core, insert and potting compound, this failure can occur before core tension failure. Usually this kind of failure occurs in a combination of heavy and thick cores with a small insert.

10.9.2.3 Adhesion failure

Adhesion failures between the insert and the potting, between the core and the face sheet or tear out failures (potting rupture around the insert) are rare in space application. Failures are usually due to deviation in the manufacturing process.

10.9.2.4 Potting diameter

Failure mode is also very strongly dependent on the potting diameter. The larger the potting diameter, the more foils under shear and the better load-carrying capability.

Potting diameter is a very complicated quantity. The size of a real potting shape can be different for pottings with the same amount of filled cells due to the position of the insert centre relative to the hexagonal cell.

The best correlation of insert out-of-plane load-carrying capability and potting diameter can be by examining the damaged cell walls, which are naturally single foils cell walls. It cannot be concluded that a great number of filled core cells gives better load-carrying capability. The critical parameter is the number of failing single cell walls. The clarification descriptions and different potting shape comparison to failed cell walls are shown in Figure 10-17 and Figure 10-18 (based on test data).

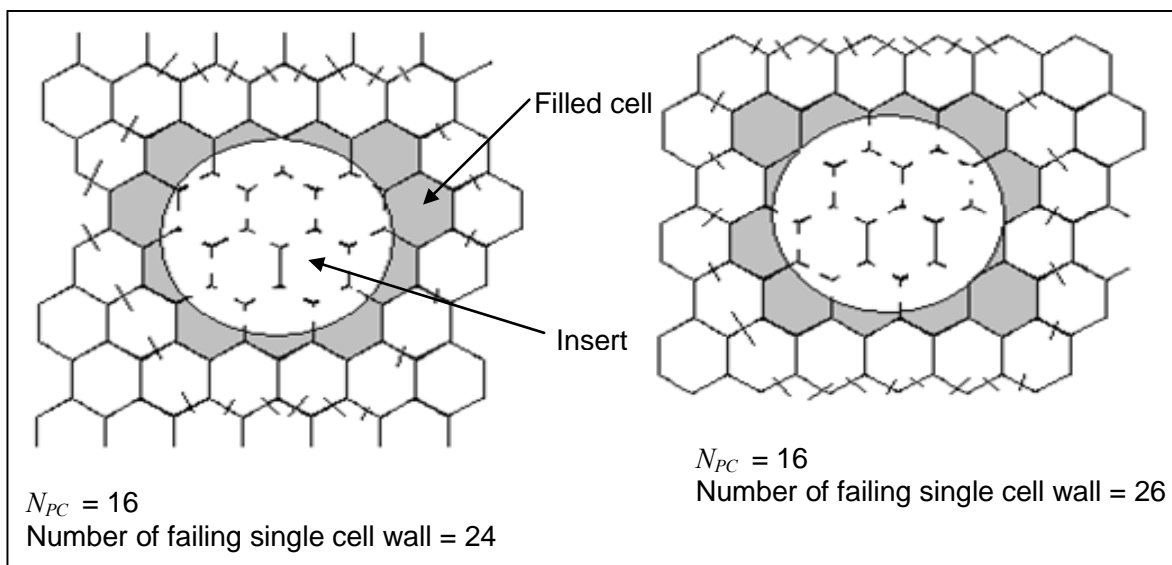

Figure 10-17: Failure modes: Non-correlation between number of the filled cells and number of the failing cell walls

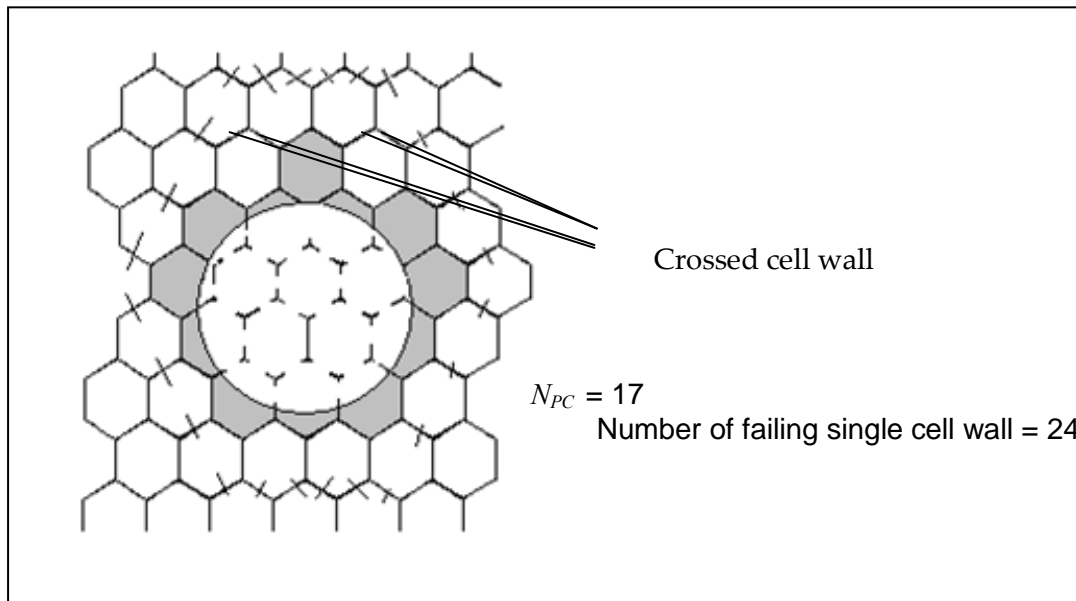

Figure 10-18: Failure modes: Unsymmetrical potting and crossed cell

It can be concluded that it is impossible to consider in advance how much bigger the real potting shape is and semi-empirical formulae for potting radius are used in the analysis of the insert load-carrying capability, [10-1].

10.9.2.5 Failures in potting compound

The three types of failures in the potting compound are:

- Insert tear-out;
- Adhesion between insert and potting compound;
- Tension failure of the potting compound.

The potting compound should have sufficient strength, so that it is not the weakest link. Stresses in the potting body are usually so low that it is not the weakest link in insert design.

Consequently, failures in the potting compound are avoided providing that the potting process is well defined and monitored. The most critical parameters in the potting process are:

- Perforation of the core material for venting during the potting process,

NOTE A different type of potting process is used for non-perforated cores.

- Suitable potting compound viscosity interval;
- Distance $h_i = (\text{bore hole depth} - \text{insert height})$;
- Ambient temperature;
- Bending of cell walls in the bore.

10.9.3 Failures under in-plane loads

10.9.3.1 General

An in-plane load can be either tension or compression. A good design practise is that torsion loads are carried by in-plane loads on several inserts. The loads are shown in Figure 10-19, [10-1].

10.9.3.2 Metallic face sheets

In the case of a metallic material under in-plane load, the face sheet fails by compressive buckling around the insert. Therefore, the capability of the insert is limited by the yield strength σ_{sy} of the face sheet material. The values of yield strength for metallic materials are usually given in supplier's data sheets. Although other failure modes are possible, it is this situation that applies to the most common cases having aluminium face sheets.

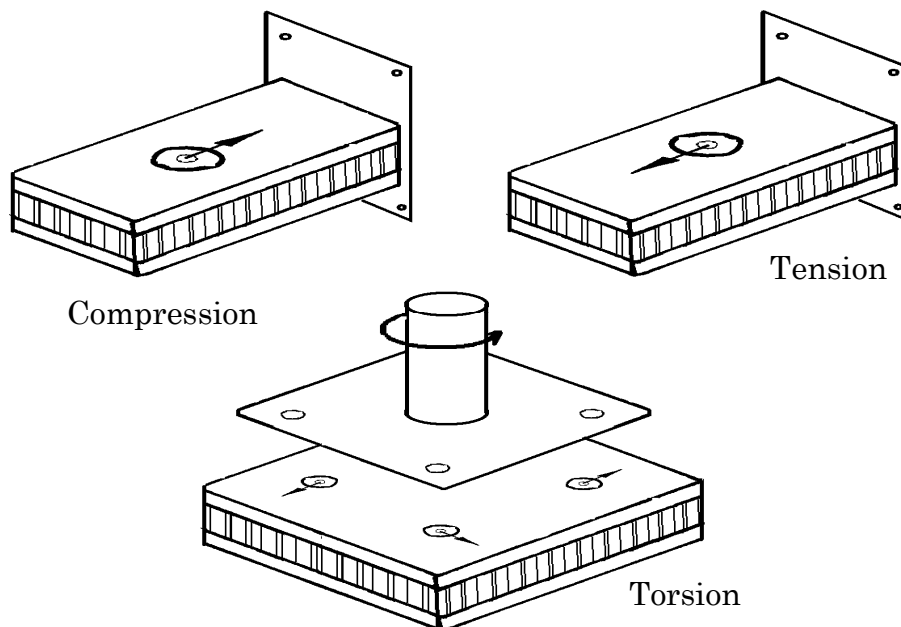

Figure 10-19: Failure modes: In-plane and torsion loads

10.9.3.3 Composite face sheets

CFRP-laminates exhibit a fairly linear relationship of loading and stress up to their failure. Their excellent performance is accompanied by a brittle failure mode. A failure can be initiated from very local, highly stressed areas. The failure mechanism has no primary or secondary stress; they all have the same relevance. The verification of the element is seen as one process, [10-1].

For CFRP-face sheets under in-plane loads, the failure modes to be considered are illustrated in Figure 10-20:

- Tensile failure (tension);
- Shear out failure (tension);
- Dimpling failure (compression);
- Bearing failure (tension or compression);
- Wrinkling.

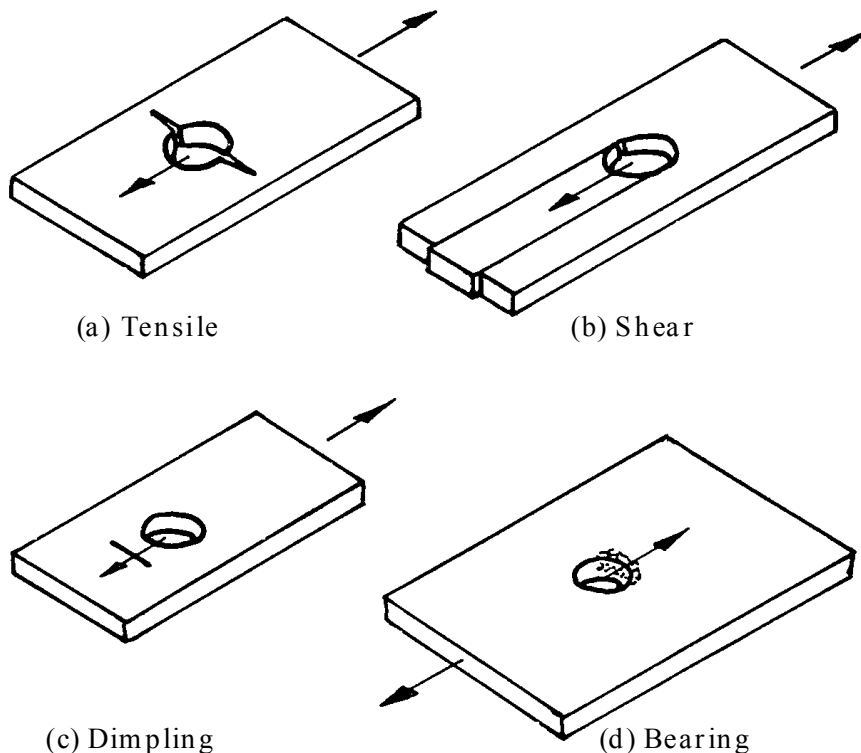

Figure 10-20: Failure modes: CFRP face sheets

A tensile failure occurs in a large panel with a sufficiently large edge distance. A local failure starts from the edge of the hole; as shown in Figure 10-20 – (a).

A shear-out failure occurs when the edge distance from the hole is small. The failure line can be at any angle depending on the lay-up of the face sheet laminate.

Under compression loading, a face sheet can buckle or dimple into the spaces between the honeycomb core walls. Thus the edge and front are clamped. Dimpling of the face sheets does not lead to failure unless the amplitude of the dimples becomes large and causes the dimples or buckles to grow across the cell walls, which results in a global failure known as wrinkling, [See also: 8.2].

A bearing failure occurs in cases in which both the edge distance and the panel width are large in comparison with the insert diameter. Such damage is localised. The failure is usually not associated with a catastrophic failure of a composite structure. The initiation of such a failure can be caused by compressive bearing at the base of the insert hole. Assuming a sinusoidal stress distribution, the most susceptible area is located in front of the central point of the hole, [10-1].

10.10 References

10.10.1 General

- [10-1] L. Sylvänen et al : Patria Finaviacomp Oy, Finland
'Analysis models for insert design rules in sandwich panels with CFRP facings'
Patria report: GS1-PFC-RP-0002 (January 2003)
ESTEC Contract No. 14076/99
- [10-2] N. Laval: Sonaca S.A., Belgium
'Inserts with flanges'
Working Group contribution (September 2003)

11

Design flow chart

11.1 Introduction

In order to achieve an appropriate design using the guidelines provided in this handbook, it is also helpful to have the steps in the form of a flow chart. Owing to different design constraints, it is quite often the case that no straight forward procedure or guide can be given for every day use. The main constraints can be defined as:

- The sandwich design and the geometry of the joint are frozen, then the appropriate insert geometry is defined.
- The sandwich parameters are given and the corresponding number of inserts and their size are selected.

For an optimum design, the sandwich can be designed at the same time as an adequate number of inserts and the insert geometry are defined.

In the case where the sandwich is predefined and the loads are given, [See: 11.2]. Where two main parameters, e.g. geometry and number of inserts, can vary, [See: 11.3].

11.2 Flow chart: Predefined sandwich and loads

Figure 11-1 summarises the steps taken during the selection of the insert configuration, when the sandwich and loads are predefined, [11-1].

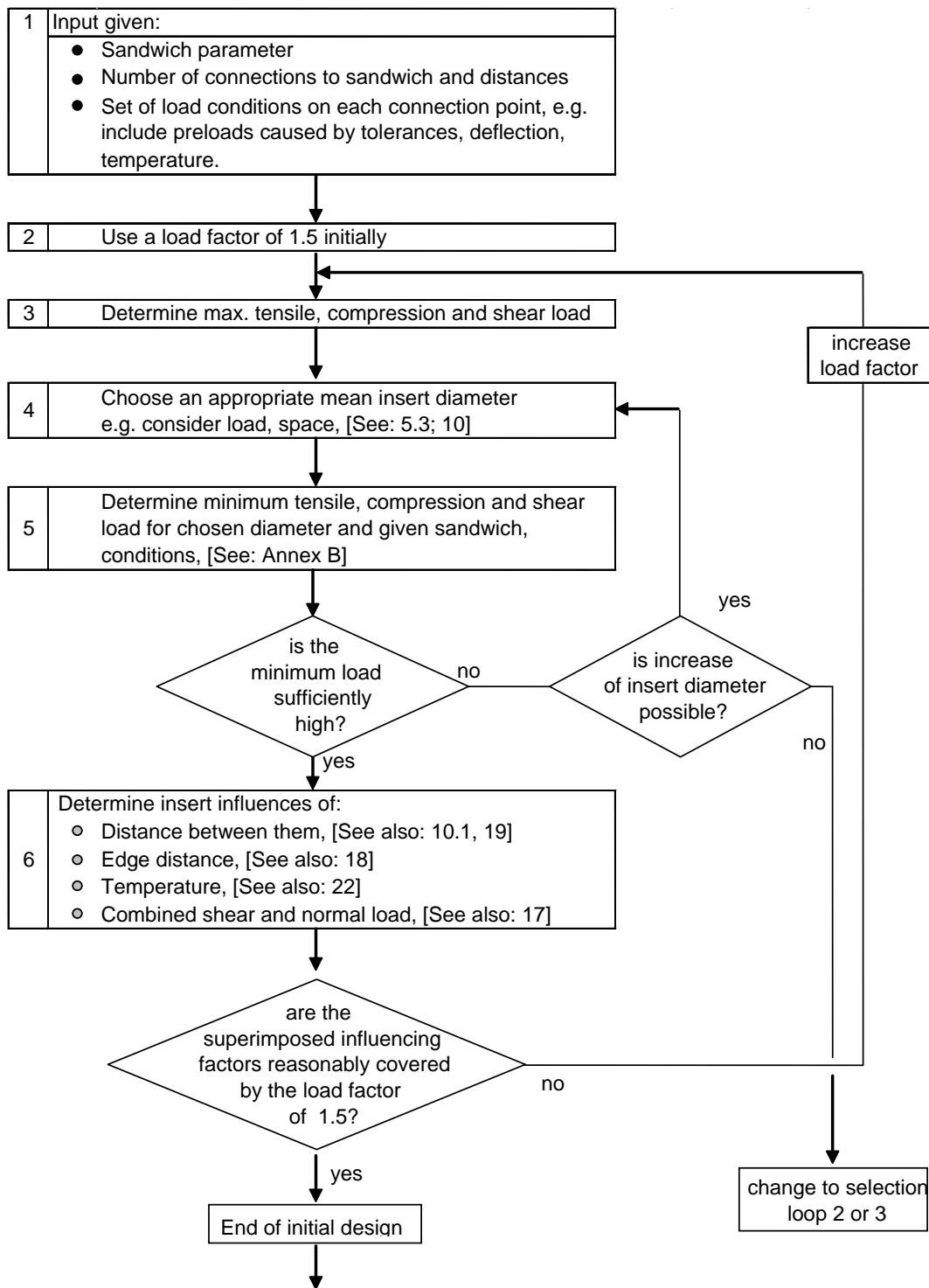

NOTE The next step would be to perform a detailed analysis if high reliability or life is stipulated.

Figure 11-1: Flow chart: Predefined sandwich and loads

11.3 Flow chart: Variable main parameters

Figure 11-2 summarises the steps taken during the selection of the insert configuration, when two main parameters, e.g. geometry and the number of inserts, can vary, [11-1].

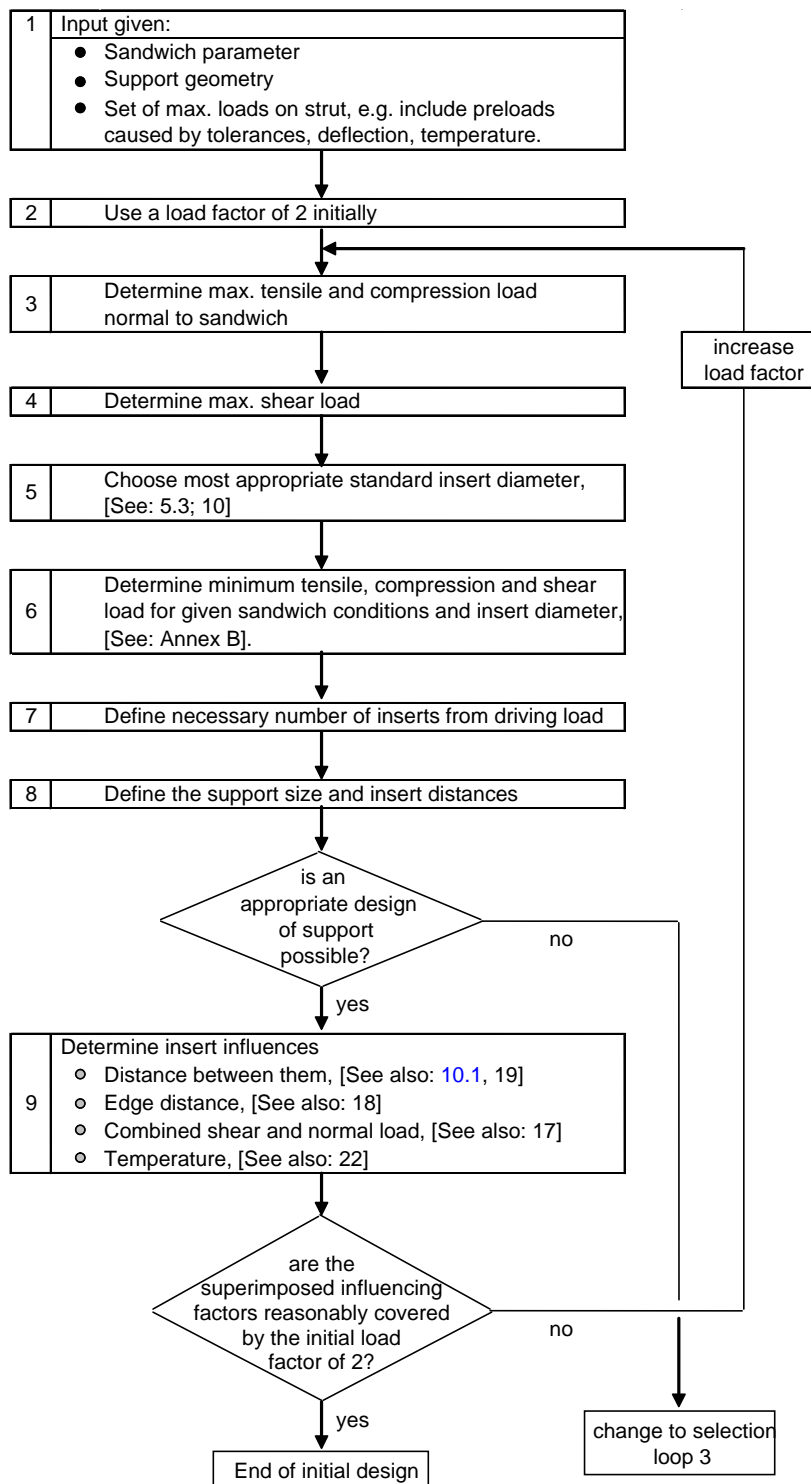

NOTE It can be necessary to repeat the loop. An additional consideration of the damage tolerance aspects is essential.

Figure 11-2: Flow chart: Variable main parameters

11.4 References

11.4.1 General

- [11-1] Jesus Gómez Garcia: EADS- Astrium (Bremen), D
'Design Guideline'
Working Group contribution (2004)

12

Tensile strength

12.1 Normal tensile load

12.1.1 General

The static strength capabilities of a standard, single potted insert without edge influences, or without interference from surrounding inserts, under out-of-plane tensile load are described.

The design guidelines presented here cover partially- and fully-potted inserts. For through-the-thickness inserts the same procedures can be used if the non-applicable failure modes are ignored. Through-the-thickness (spool) inserts cannot fail by core or potting tension beneath the insert.

For the strength capability of non-standard insert designs, [See: A.3; F.6].

12.1.2 Failure modes

The decisive failure modes affecting the static strength capability P_{SS} of an insert under tensile load in a sandwich panel are shown in Figure 12-1.

These failure modes are mainly influenced by the height of core c in combination with the height of potting h_p .

[See also: 10.9]

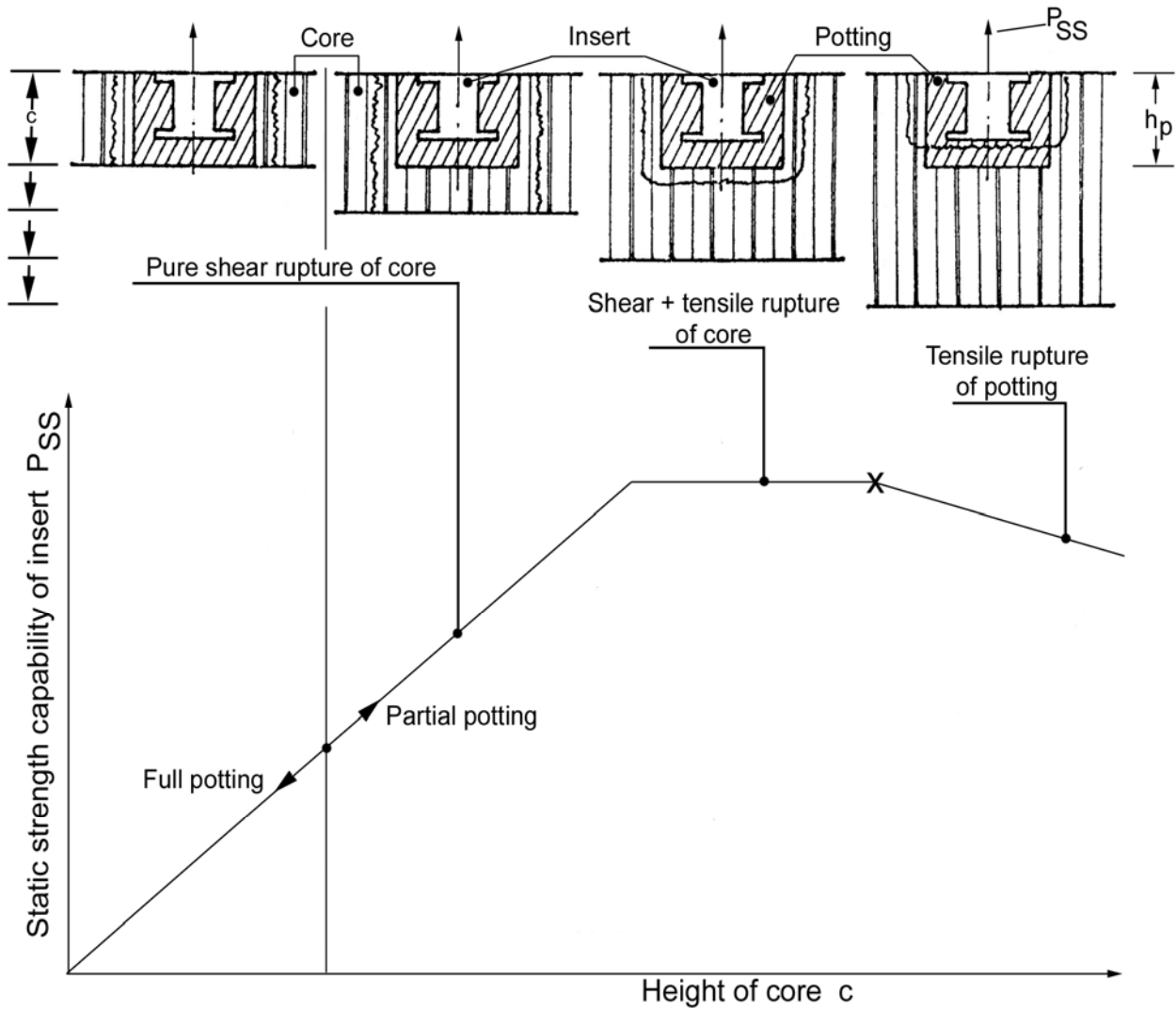

Figure 12-1: Failure modes in relation to the core height

12.1.3 Shear rupture: core surrounding the potting

12.1.3.1 Fully potted insert

For fully potted inserts, i.e. $h_p = c$, the insert fails by shear rupture of the core surrounding the potting, especially by shear rupture of the undoubled core foils. Therefore, the limiting capability property is the core shear strength $\tau_{c\ crit}$.

[See: 6.5; Table 6-3; Table 6-4]

The insert capability P_{crit} increases quasi-linearly with the core height c .

12.1.4 Tensile rupture: core underneath the potting

12.1.4.1 Partially potted insert: Metal core

For partially potted inserts ($c > h_p$), the core underneath the potting is subjected to a tensile stress. In an aluminium core, this tensile stress increases for constant h_p with increasing core height. However, up to a certain height of core, the insert still fails by shear rupture of core around the potting, and the insert capability P_{crit} still increases quasi-linearly with core height c . This quasi-linear behaviour results from the early shear-buckling of the single core foils, which maintains an approximately constant shear stress over the total core height.

NOTE Although partially potted, the insert exhibits the same behaviour as that of a fully potted insert.

If $(c - h_p)$ reaches a certain limit, the tensile stress underneath the potting reaches the tensile strength $\sigma_{c\ crit\ t}$ of the core.

[See: 6.6; Table 6-3]

For greater core heights, the shear rupture of the core around the potting and tensile rupture of the core underneath the insert occur together: the insert capability is then simultaneously limited by $\tau_{c\ crit}$ and $\sigma_{c\ crit\ t}$ and is practically independent of further increases in core height.

[See also: B.1]

12.1.4.2 Partially potted insert: Non-metallic core

In non-metallic cores, e.g. Nomex[®], GFRP, the insert capability for constant h_p increases only slightly with increasing core height c . The reason why this behaviour differs from that of aluminium cores is that the rigid non-metallic cores cannot adequately distribute stress concentrations by means of local deformation.

The stress concentration at the lower flange of the partially-potted insert is considered to be conservatively accounted for by a stress-concentration factor for partial potting, K_{pp} .

[See: C.3]

12.1.4.3 Notes on insert capabilities in non-metallic cores

The capabilities of inserts in non-metallic cores are determined by using measured core properties in combination with an analytical model verified primarily with metallic cores. They can be used for preliminary design but need to be substantiated by testing of the actual configuration.

Where a thin, flexible, non-metallic core has stiff, relatively thick, metallic face sheets, the load applied normal to the panel can be carried primarily by the face sheets. The strength of the face sheet needs to be checked, in order to ensure that the load-distribution, defined by the analytical model, is still valid.

The load in one face sheet can be approximated by:

$$P_f = \frac{P_{ss}}{2-b_p c} \quad [12.1-1]$$

The criterion that this load can be transmitted by both face sheets has not been taken into account in the design graphs provided in Annex B, [See: B.2].

NOTE This type of check is not necessary for inserts in metallic cores because the model has been verified by many tests that implicitly covered this point.

12.1.5 Tensile rupture: potting underneath the insert

Like the core underneath the potting, the potting underneath the insert is subjected to a tensile stress that increases with increasing core height.

For a certain core height, this stress can exceed the tensile strength $\sigma_{R\ crit}$ of the potting compound before the tensile strength $\sigma_{c\ crit\ t}$ of the core underneath the potting is reached. This is the case for heavy cores and can also occur for fully potted inserts.

A further increase in the core height results in a slight decrease in the insert capability because P_{crit} is then only limited by $\sigma_{c\ crit\ t}$.

Owing to the rigidity of the potting, no advantage can be taken from the shear strength of the core. The shear stresses in the core around the potting decrease with a further increase of the core height c .

12.1.5.1 Effective stress concentration

For the usual types of potting compound, i.e. a syntactic foam, tensile strength values that include the effective stress concentration K_t (derived from insert test results), are:

- $\sigma_{R\ crit\ min} = 9\text{ N/mm}^2$
- $\sigma_{R\ crit\ typ} = 12\text{ N/mm}^2$

These values are lower than the potting material strength given in Table 7-1. In this case, a value for K_t less than 1.8 is advisable.

NOTE K_t values for different potting compounds are determined by testing.

12.2 Basic parameters

The basic parameters for the determination of the capability of potted inserts under tensile load are summarised in Table 12-1 and are related to the:

- Face sheets:
 - thickness, f
 - material:
 - E_f Young's modulus, and
 - ν_f Poisson's ratio.
- Insert, [See: Table 12-2; Table 12-3]
 - diameter of insert d_i influencing the potting radius b_p
 - flange radius of insert b_i
 - height of insert h_i influencing the potting height h_p
- Core:
 - core height, c
 - cell size, S_c ; shear modulus G_c
 - foil thickness, t_0 influencing shear strength $\tau_{c\ crit}$
 - core material tensile strength $\sigma_{c\ crit\ t}$

[See also: 12.1 for comments on insert types; Annex A]

Table 12-1: Properties for determining potted insert capability: Tensile load

Properties of components		Minimum values $P_{SS\ t\ min}$ according to:		Average or Typical values $P_{SS\ t\ av}$ according to:	
Sheet	Thickness	f		f	
	Young's modulus	E_f		E_f	
	Poisson's ratio	ν_f		ν_f	
Potting	Effective radius	$b_{p\ min}$	Figure 6-4 Table 12-2 Table 12-3	$b_{p\ typ}$	Figure 6-4 Table 12-2 Table 12-3
	Real radius	$b_{R\ min}$	Figure 7-1 Table 12-2 Table 12-3	$b_{R\ typ}$	Figure 7-1 Table 12-2 Table 12-3
	Height	$h_{p\ min}$	Figure 7-2	$h_{p\ typ}$	Figure 7-2
	Tensile strength	$\sigma_{R\ crit\ min}$	= 9 N/mm ²	$\sigma_{R\ crit\ typ}$	= 12 N/mm ²
Core	Height	c		c	
	Shear modulus	G_c	Table 6-3 Table 6-4	G_c	Table 6-3 Table 6-4
	Shear strength	$\tau_{c\ crit\ min}$	Table 6-3 Table 6-4	$\tau_{c\ crit\ typ}$	Table 6-3 Table 6-4
	Tensile strength	$\sigma_{c\ crit\ min}$	Table 6-3 Table 6-4	$\sigma_{c\ crit\ typ}$	Table 6-3 Table 6-4
RC (1)	Perforated core	RC	= $(1.72 - 0.0063\ c - 0.2641f)$	RC	= $(1.207 - 0.00544\ c - 0.2088f)$
	Unperforated core	RC	= 0.91	RC	= 1
<p>NOTE (1) Model correlation coefficient, [See: 12.3]. c = core height, formerly shown as h_c in PSS-IDH. NOTE (2) [See also: Annex G for listing of equations]</p>					

Table 12-2: Perforated cores: Effective and real potting radius versus insert diameter

Core cell size, $S_c = 4.8$ mm							3/16"
Insert diameter, d_i		9	11	14	17.5	22	mm
Potting radius, b_p	min	7.70	8.63	10.03	11.66	13.75	mm
	typ	8.28	9.28	10.78	12.54	14.79	mm
Real potting radius, b_R	min	6.18	7.18	8.64	10.43	12.68	mm
	typ	6.9	7.9	9.4	11.15	13.4	mm
Core cell size, $S_c = 3.2$ mm							1/8"
Insert diameter, d_i		9	11	14	17.5	22	mm
Potting radius, b_p	min	6.33	7.26	8.66	10.29	12.39	mm
	typ	6.81	7.81	9.31	11.07	13.32	mm
Real potting radius, b_R	min	5.62	6.62	8.12	9.87	11.12	mm
	typ	6.1	7.1	8.6	10.35	12.6	mm
NOTE Perforated cores, e.g. aluminium. $b_{p \min} = 0.93192 b_i + 0.874 S_c - 0.66151$ $b_{p \text{ typ}} = 1.002064 b_i + 0.94035 S_c - 0.7113$ $b_i = 0.5 d_i$							$b_{R \min} = b_i + 0.35 S_c$ $b_{R \text{ typ}} = b_i + 0.5 S_c$

Table 12-3: Non-perforated cores: Effective and real potting radius versus insert diameter

Core cell size, $S_c = 4.8$ mm							3/16"
Insert diameter, d_i		9	11	14	17.5	22	mm
Potting radius, b_p	min	7.41	8.31	9.66	11.24	13.26	mm
	typ	8.34	9.34	10.84	12.59	14.84	mm
Real potting radius, b_R	min	6.18	7.18	8.64	10.43	12.68	mm
	typ	6.9	7.9	9.4	11.15	13.4	mm
Core cell size, $S_c = 3.2$ mm							1/8"
Insert diameter, d_i		9	11	14	17.5	22	mm
Potting radius, b_p	min	6.29	7.19	8.54	10.12	12.14	mm
	typ	7.06	8.06	9.56	11.31	13.56	mm
Real potting radius, b_R	min	5.62	6.62	8.12	9.87	12.12	mm
	typ	6.1	7.1	8.6	10.35	12.6	mm
NOTE Non-perforated cores, e.g. Nomex®, GFRP. $b_{p \min} = 0.9 b_i + 0.7 S_c$ $b_{p \text{ typ}} = b_i + 0.8 S_c$ $b_i = 0.5 d_i$							$b_{R \min} = b_i + 0.35 S_c$ $b_{R \text{ typ}} = b_i + 0.5 S_c$

12.2.1 Out-of-plane loads: Insert strength

12.2.1.1 Sensitivity to parameters

The sensitivity of each component in out-of-plane cases are calculated using the expression, [12-1]:

$$\tau(r) = \frac{P I_p}{\pi(h+c)I} \times \left(\frac{1}{r} - \frac{I_1(\alpha r)}{a b_p} \frac{b_p K(\alpha b_p) - a K_1(\alpha a)}{I_1(\alpha a) \times K_1(\alpha b_p) - I_1(\alpha b_p) \times K_1(\alpha a)} - \frac{K_1(\alpha r)}{a b_p} \frac{a I_1(\alpha a) - b_p I_1(\alpha b_p)}{I_1(\alpha a) \times K_1(\alpha b_p) - I_1(\alpha b_p) \times K_1(\alpha a)} \right) \quad [12.2-1]$$

where:

- P applied out-of-plane load
- τ core shear stress
- f face sheet thickness; assuming face sheets are similar
- f_1, f_2 individual face sheet thicknesses
- h total sandwich thickness = $c + f_1 + f_2$
- α outer radius of panel
- b_p effective potting radius
- b_R real potting radius
- I_p moment of inertia of the panel

$$= \frac{f_1 f_2 (h+c)^2}{4(h-c)} \quad [12.2-2]$$

- I_s moment of inertia of the face sheets

$$= \frac{f_1^3 + f_2^3}{12} \quad [12.2-3]$$

- $I = I_p + I_s$

- α ratio of stiffness between core and face sheets

$$= \sqrt{\frac{G_c (h-c) I}{E c f_1 f_2 I_s}} \quad [12.2-4]$$

- G_c shear modulus of the core

$$E = \frac{E_s}{1 - \nu_s^2} \quad [12.2-5]$$

- $I_1(x), K_1(x)$ Bessel functions, where $x = \alpha r, \alpha a, \alpha b$

The values are shown for, [12-1]:

- core shear failure in Table 12-4.
- core tension failure in Table 12-5.

NOTE The sensitivity is calculated given 5% deviation for each component.

Table 12-4: Out-of-plane capability: Effect of components on core shear

	Original values		+5% values		Increase (N)	Influence (%)
	(N)		(N)			
b_p	11.42 mm	3784	11.99 mm	3974	190	5.02
c	30.00 mm	3784	31.50 mm	3959	175	4.62
$\tau_{c\ crit}$	1.46 MPa	3784	1.53 MPa	3973	189	4.99
f	0.30 mm	3784	0.32 mm	3825	41	1.08

NOTE Example case: Partially potted; D17, 3/16-0.001P; $c = 30$ mm, $f = 0.3$ mm. Failure mode: Core shear.

Table 12-5: Out-of-plane capability: Effect of components on core tension

	Original values		+5% values		Increase (N)	Influence (%)
	(N)		(N)			
b_p	8.64 mm	6258	9.07 mm	6660	402	6.42
c	40.00 mm	6258	42.00 mm	6270	12	0.19
$\sigma_{c\ crit\ t}$	8.45 MPa	6258	8.87 MPa	6389	131	2.09
$\tau_{c\ crit}$	1.46 MPa	6258	1.53 MPa	6439	181	2.89
f	0.30 mm	6258	0.32 mm	6329	71	1.13

NOTE Example case: Partially potted; D14, 1/8-0.001P; $c = 30$ mm, $f = 0.3$ mm. Failure mode: Core tension.

The contributions of the different components for, [12-1]:

- Core shear in Figure 12-2
- Core tension in Figure 12-3

**Sensitivity of Out-of-plane
 Core shear**

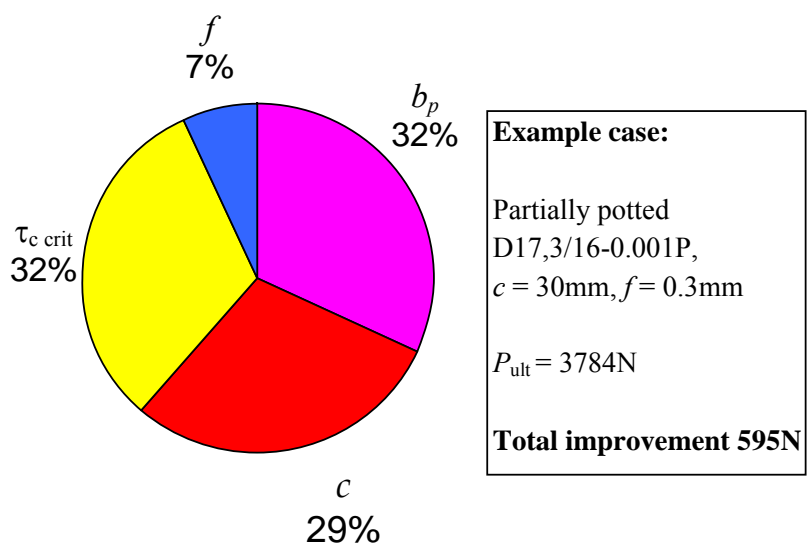

Figure 12-2: Out-of-plane capability: Contributions of the main components on improved core shear

Sensitivity of Out-of-plane Core tension

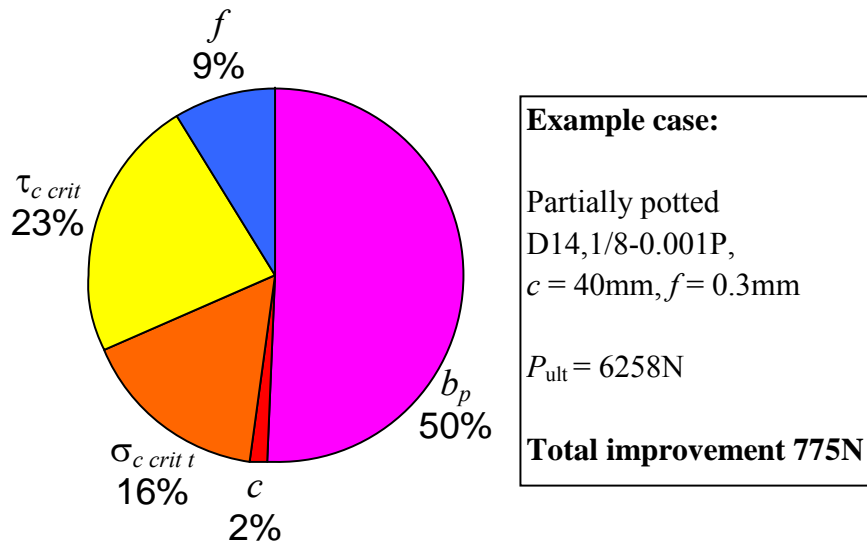

Figure 12-3: Out-of-plane capability: Contributions of the main components on improved core tension

Based on the results in Figure 12-2 and Figure 12-3, it can be concluded that the face sheet thickness, f , has very limited influence on out-of-plane capacity when the failure mode is core shear or core tension, [12-1].

12.3 Minimum and average design values

12.3.1 Overview

Two levels of insert capabilities have been determined and plotted as a function of core height:

- Minimum insert capabilities $P_{SS\ min}$
- Average insert capabilities $P_{SS\ av}$

[See also: 13.2; Annex B]

12.3.2 Minimum insert design values

12.3.2.1 General

The minimum insert design values are based upon:

- Minimum strength properties;
- Minimum potting dimensions;
- Model correlation coefficient, RC

12.3.2.2 Minimum strength properties

Minimum strength properties of core shear strength with a probability greater of 90%.

Where those data were unavailable, minimum guaranteed values, provided by the supplier, are used and indicated on the strength design plots.

12.3.2.3 Minimum potting dimensions

Minimum potting dimensions with a probability greater than 90%:

- Perforated cores, e.g. aluminium: Where statistical data are available Eqn. [7.3-4] is used, [See: 7.3].
- Unperforated cores, e.g. Nomex[®], GFRP: Eqn. [7.3-5] is used to determine the minimum potting dimensions, [See: 7.3]

12.3.2.4 Model correlation coefficient

Model correlation coefficient *RC*, with a probability greater of 90% of the tested or analysed inserts:

- Perforated aluminium core:

$$RC = 1.172 - 0.0063 \times c - 0.2641 \times f \quad [12.3-1]$$

- Other types of core:

$$RC = 0.91$$

NOTE c = core height, formerly shown as h_c in PSS-IDH.

12.3.2.5 Design values

The possibility that the three minima with an individual probability of 90% apply together is so unlikely that the resulting values are regarded as design "A" values ($P = 99\%$; $CL = 95\%$).

NOTE The analytically determined values of partially potted inserts in non-metallic core have not been confirmed by as many tests as those within a metallic core. Therefore, these values can be used for preliminary design only.

If the minimum core strength from incoming inspection just meets the "guaranteed minimum value", this is considered to be covered by the safety factor of 1.5 (a conservative value).

[See: 12.4]

12.3.3 Average insert values

12.3.3.1 General

The average insert values are based upon:

- Average strength properties;
- Average potting dimensions;
- Model correlation coefficient, *RC*.

12.3.3.2 Average strength properties

Average strength properties of core shear strength with a probability greater than 50%.

Where those data were unavailable, the typical values provided by the supplier are used and indicated on the strength design plots.

12.3.3.3 Average potting dimensions

Average potting dimensions with a probability greater than 50%:

- Perforated aluminium core: where statistical data are available, Eqn. [7.3-4] is used, [See: 7.3].
- Non-perforated (Nomex[®], GFRP) cores: Eqn. [7.3-5] is used to determine the average potting dimensions, [See: 7.3].

12.3.3.4 Model correlation coefficient

Model correlation coefficient *RC* with a probability greater than 50 % of the tested or analysed inserts:

- Perforated aluminium core:

$$RC = 1.207 - 0.00544 \times c - 0.2088 \times f \quad [12.3-2]$$

- Other types of core:

$$RC = 1$$

NOTE 1 *c* = core height, formerly shown as *h_c* in PSS-IDH.

NOTE 2 Verification of 'reliability coefficients' applies to the sandwich panel dimensions in this handbook. Panel dimensions exceeding 80 mm by 0.8 mm need a different method.

12.4 Safety factors

12.4.1 Load capability

The load-carrying capabilities provided are determined for perforated aluminium cores in use by statistical analysis on groups of several hundred samples.

Based upon the variability identified, the given capabilities are considered as in agreement with design "A" values (*P*=99%; *CL*=95%).

Therefore there is no need for an increased safety factor to account for the high variability generally experienced if the installation of the insert is performed properly, i.e. in accordance with the manufacturing process.

A safety factor of 1.5 against the minimum "A" ultimate capabilities provided is therefore possible provided that there are no other requirements within the program.

NOTE Within the industry, a safety factor of 2 is often stipulated, probably arising from similarity with other structures. This can be reduced to 1.5 provided that all the conditions meet those stated.

12.4.2 Failure modes

The insert capability is limited to loads resulting in large permanent deformations.

As initiation of significant deformation begins close to ultimate load, there is (with a safety factor of 1.5 on ultimate capabilities) no reason for a separate verification of a "no permanent deformation" requirement with respect to failure of the insert due to core failure.

NOTE A separate verification can be necessary for environmental factors or other unusual failure modes, e.g. at elevated temperatures.

12.5 Permissible tensile loads

12.5.1 General

Standard type partially- and fully-potted inserts are covered by the design rules provided here. For through-the-thickness inserts the same procedures can be used if the non-applicable failure modes are ignored. Through-the-thickness (spool) inserts cannot fail by core or potting tension beneath the insert.

[See also: A.3; F.6 for non-standard inserts]

12.5.2 Insert capability graphs

The permissible tensile or compressive load graphs in Annex B show the capability of inserts to withstand tensile loading plotted as a function of the core height c with face sheet thickness f . The different graphs relate to different insert diameter d_i and to different core types.

[See also: B.2]

The occasional crosses (x) in some load-capability curves denote a tensile rupture of the potting which should be avoided, e.g. by increasing the insert height h_i , [See: 12.6].

12.5.3 Design values

12.5.3.1 Minimum values

$P_{SS \text{ } t \text{ } min}$ values are regarded as design "A" values ($P = 99\%$; $CL = 95\%$) for all cases where the usual incoming inspection is performed and where the inserts are installed in accordance with the manufacturing and quality assurance procedures, [See: 23.1; 24.1 and 25.1 for manufacturing; 26.1; 27.1 and 28.1 for QA].

12.5.3.2 Average values

The $P_{SS\tau_{av}}$ values are achieved in quality control testing, [See: 28.1].

In addition, 70% of the average capability values are applicable to design without further investigation provided that the:

- Core properties meet at least the typical or average values listed in Table 6-3 (metallic) and Table 6-4 (non-metallic).
- Manufacturing conforms with manufacturing and quality assurance procedures, [See: 23.1; 24.1 and 25.1 for manufacturing; 26.1; 27.1 and 28.1 for QA].
- Load transfer is maintained by a set of inserts close together with different loads. By potential load redistribution, a reduced factor of safety can be considered.

12.6 Influence of insert height

NOTE The information given here applies only to potted inserts.

12.6.1 Insert capability graphs

Although the capability graphs, [See: Annex B] are established for an insert height, $h_i = 9$ mm, they are also applicable for other h_i values.

12.6.2 Different insert heights

A modification of insert height, h_i only shifts the break of the curves towards lower or higher c -values, according to the relationship:

$$C^{I*} = C^I + h_i^* - h_i \quad [12.6-1]$$

Where:

- h_i basic insert height = 9 mm
- h_i^* new insert height
- c^I c-value at curve break for basic insert height h_i
- c^{I*} new c-value at curve break for new insert height h_i^*

The shift is shown schematically in Figure 12-4.

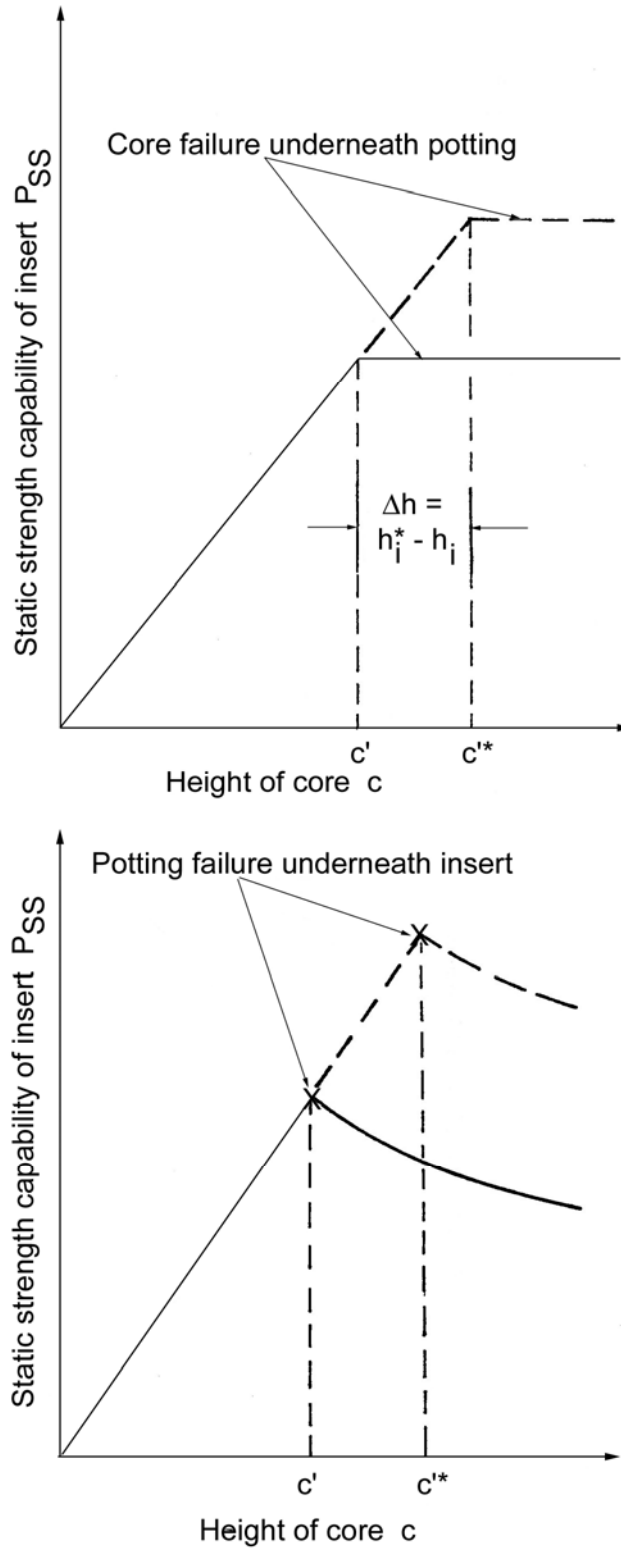

Figure 12-4: Influence of insert height on insert capability

The increase in h_i increases the insert capability only for those cases where the failure occurs in the:

- Core underneath the potting, or
- Potting underneath the insert.

An increase in h_i is advised especially if rupture of the potting underneath the insert is anticipated.

12.7 Composite face sheet

12.7.1 Effect of anisotropy

The out-of-plane load carrying capability of insert-sandwich panel geometry is nearly totally dependant on the core properties; based on test data, [12-1].

The calculation procedure which is derived to define the out-of-plane capability of the insert-sandwich systems with metal face sheets is also valid for insert-sandwich systems with face sheets made from CFRP or GFRP.

The expressions used for the composite face sheets are:

- Young's modulus:

$$E = \sqrt{E_x E_y} \quad [12.7-1]$$

- Poisson's ratio:

$$\nu = \sqrt{\nu_{xy} \nu_{yx}} \quad [12.7-2]$$

12.7.2 Loading by moments

Although CFRP face sheets are complex, the situation is generally somewhat similar to metallic face sheets, whereby torsion and bending moments are carried by a couple of inserts.

[See: 15.3, 16.3]

[See also: 10.2]

12.8 References

12.8.1 General

- [12-1] Lassi Syvänen, Kari Marjoniemi, Ari Ripatti, Markku Pykäläinen: Patria Finaviacomp Oy, Finland
- 'Analysis models for insert design rules in sandwich panels with CFRP facings'
- Patria report: GS1-PFC-RP-0002 (January 2003)
- ESTEC Contract No. 14076/99

13

Compressive strength

13.1 Normal compressive load

13.1.1 General

The general statements made in 12.1 for normal tensile load acting on potted inserts are also valid for compressive out-of-plane load with some exceptions, described here.

Partially- and fully-potted inserts are covered by the design rules presented here. For through-the-thickness inserts the same procedures can be used if the failure modes which cannot occur are ignored. Through-the-thickness (spool) inserts cannot fail by core compression beneath the insert.

For the strength capability of non-standard insert designs, [See: A.3; F.6].

13.1.2 Partially-potted inserts

The tensile strength $\sigma_{c\ crit\ t}$ of the core underneath the potting is replaced by the compressive strength $\sigma_{c\ crit\ c}$ listed in Table 6-3 (metallic) and Table 6-4 (non-metallic).

13.1.3 Potting strength

This does not have a limiting influence on the insert capability, because the compressive strength of the potting:

- Far exceeds its tensile strength;
- Even higher than the compressive strength of the core.

13.1.4 Increased face sheet thickness

When $f > 0.6$ mm, the insert capability is reduced because a failure of the bond between the upper face sheet and core can occur near the insert. This is taken into account by neglecting the load contribution of the upper face sheet.

13.1.5 Insert capabilities

13.1.5.1 Minimum

The minimum insert capability is given by:

$$P_{SS\ c\ min} = RC \times P_{crit\ min} \quad [13.1-1]$$

where: $RC = 0.89$

13.1.5.2 Average

The average insert capability is given by:

$$P_{SS\ c\ av} = RC \times P_{crit\ av} \quad [13.1-2]$$

where: $RC = 1$

13.2 Permissible compressive loads

The statements made in 12.5 for permissible tensile loads also apply with respect to permissible compressive loads.

Standard partially- and fully-potted inserts are covered by the design rules presented here. For through-the-thickness inserts the same procedures can be used if the non-applicable failure modes are ignored. Through-the-thickness (spool) inserts cannot fail by core compression beneath the insert.

13.2.1 Graphs of permissible static insert loads

In Annex B, the two determined levels of insert capabilities are plotted as function of the core height.

[See: B.2 for key to insert design graphs]

13.3 Composite face sheet

In general, the guidelines that apply for metallic face sheets are also valid for CFRP face sheets, [See: 12.7].

As discussed in 10.2, loading of an insert is generally performed via a bracket, box or washer having a footprint size larger than the potting dimension (taking into account any non-regularity of the potting area). The pre-load of the bolts connecting the bracket with the insert is to be sufficiently high in order to prevent any gapping.

[See Figure 10-3, Figure 10-4]

These provisions ensure that all compressive loads are transmitted via the facing in the area of the potting.

[See also 10.2]

Support of the CFRP laminate can be compromised by slight variations in tolerance of the components, i.e.:

- finishing operations performed on protruding inserts after potting can damage thin CFRP laminates,
- slippage between the brackets and facing, e.g. under vibration loads, can cause damage on the surfaces of the CFRP facings,
- Misalignment or poor fabrication can result in gapping in the contact area, such that the intended support around the insert hole is not achieved.

One option is to use a protruding insert, as shown in Figure 13-1. In this case the border of the insert hole is bonded with resin during potting [See also: 10.2, 10.3].

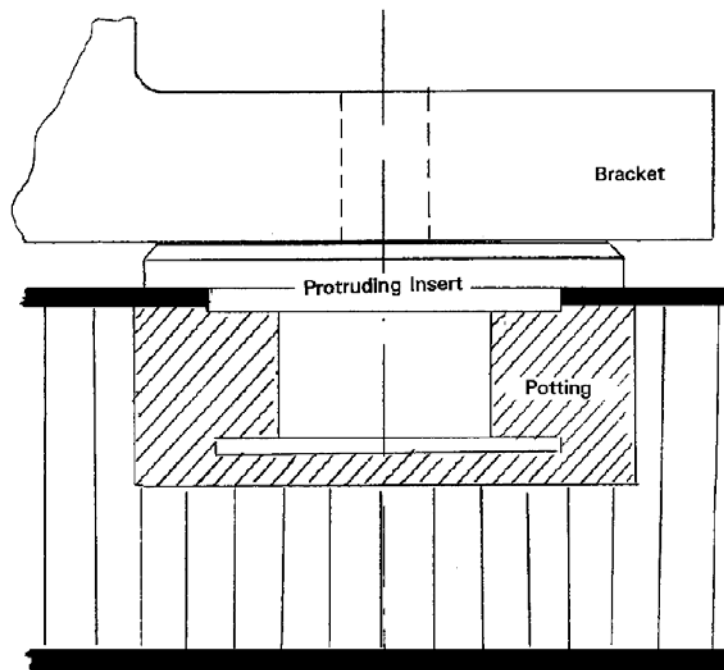

Figure 13-1: Compressive strength: Protruding insert

14

Shear strength

14.1 Shear (in-plane) load

14.1.1 Effect of in-plane load

The shear or in-plane load Q , applied to the insert is considered to act in the midplane of the upper face sheet, as shown in Figure 14-1.

The diameter D of the foot of the attached part needs to be at least as large as the typical potting diameter, i.e.:

$$D \geq 2b_p \approx 2(b_t + 4 \text{ mm}) \quad [14.1-1]$$

where:

b_p potting radius.

This is necessary to provide sufficient clamping of the insert and prevent the insert from being pushed under the upper face sheet; as shown in Figure 14-1.

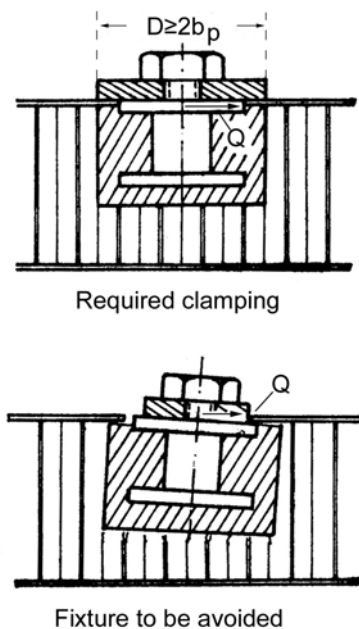

Figure 14-1: Shear-loaded inserts: Clamping conditions

14.1.2 Effect of face sheet material

14.1.2.1 Metallic face sheet

The insert-sandwich combination fails by compressive buckling of the upper face sheet around the socket of the attached part.

Therefore, the capability of the shear-loaded insert is limited by the yield strength σ_{fy} of the face sheet material.

[See also: 6.2; 14.3]

14.1.2.2 Non-metallic face sheet

The failure mode of in-plane, shear-loaded insert-sandwich combinations with composite face sheets, e.g. CFRP, can differ from that of metallic face sheets, [See also: 14.3].

The failure mode, as well as the off-axis yield strength, depends on the:

- Material used;
- Number of layers;
- Stacking sequence.

[See also: 6.2]

14.1.3 Effect of partial clamping

A small portion of the load is carried by the core due to the partial clamping of the core in the vicinity of the upper face sheet. This part of the load, Q_c , depends on the stiffness of the core with respect to the load direction.

Conservatively, only the core stiffness in the weaker W -direction is considered, [See also: 6.3; 6.5].

This part of the load can be given by the semi-empirical formula:

$$Q_c = 8b_p^2 \tau_{W\text{ crit}} \quad [14.1-2]$$

where:

$\tau_{W\text{ crit}}$ shear strength of core in W -direction.

NOTE The critical shear load is quasi-independent of the core height, c .

14.2 Permissible shear load

Standard partially- and fully-potted inserts are covered by the design rules presented. For through-the-thickness inserts the same procedures can be used for each face sheet or skin.

The total capacity also depends upon whether each face sheet is loaded equally, i.e. zero moment on panel; or just one, i.e. moment on the panel equals the applied shear load, times the offset to the neutral axis of the panel. The latter is the normal case for a partially-potted insert.

In cases where both face sheets are used, the core component can be used in addition to the face sheet component but, as the derivation of the core component is semi-empirical, test verification is needed if it is used on both face sheets.

The permissible shear load, Q_{SS} , which can be applied to the insert is given by the semi-empirical formula:

$$Q_{SS} = 8b_p^2 \tau_{W \text{ crit}} + 2fb_p \sigma_{fy} \quad \text{for } b_p \leq 11 \text{ mm} \quad [14.2-1]$$

Where:

- b_p potting radius, [See: 7.3; Table 12-2; Table 12-3]
- $\tau_{W \text{ crit}}$ shear strength of core in W-direction, [See: Table 6-3; Table 6-4].
- σ_{fy} yield strength of face sheets, according to standards, [See: 6.6].
- f thickness of upper face sheet.

[See also: 14.3 for composite face sheets]

This expression is limited to values of b_p less than 11 mm due to the difficulty of clamping greater potting radii, [See: Figure 14-1].

NOTE $b_p = 11$ mm is used in Eqn. [14.2-1] for $b_p > 11$ mm.

14.3 Composite face sheet

14.3.1 Strength

These comments apply to inserts remote from edges or other disturbances. The analysis method for in-plane load is based on test data. However, the results of these analyses do not correlate very well with the tests, [14-1].

The best correlation is with metallic face sheets and face sheets with 0°/90° fibre orientations.

The worst correlation is with face sheets with ±45° fibres orientations and HT high tenacity or HM high modulus fibres.

The correlation is shown in Figure 14-2 and Figure 14-3, [14-2].

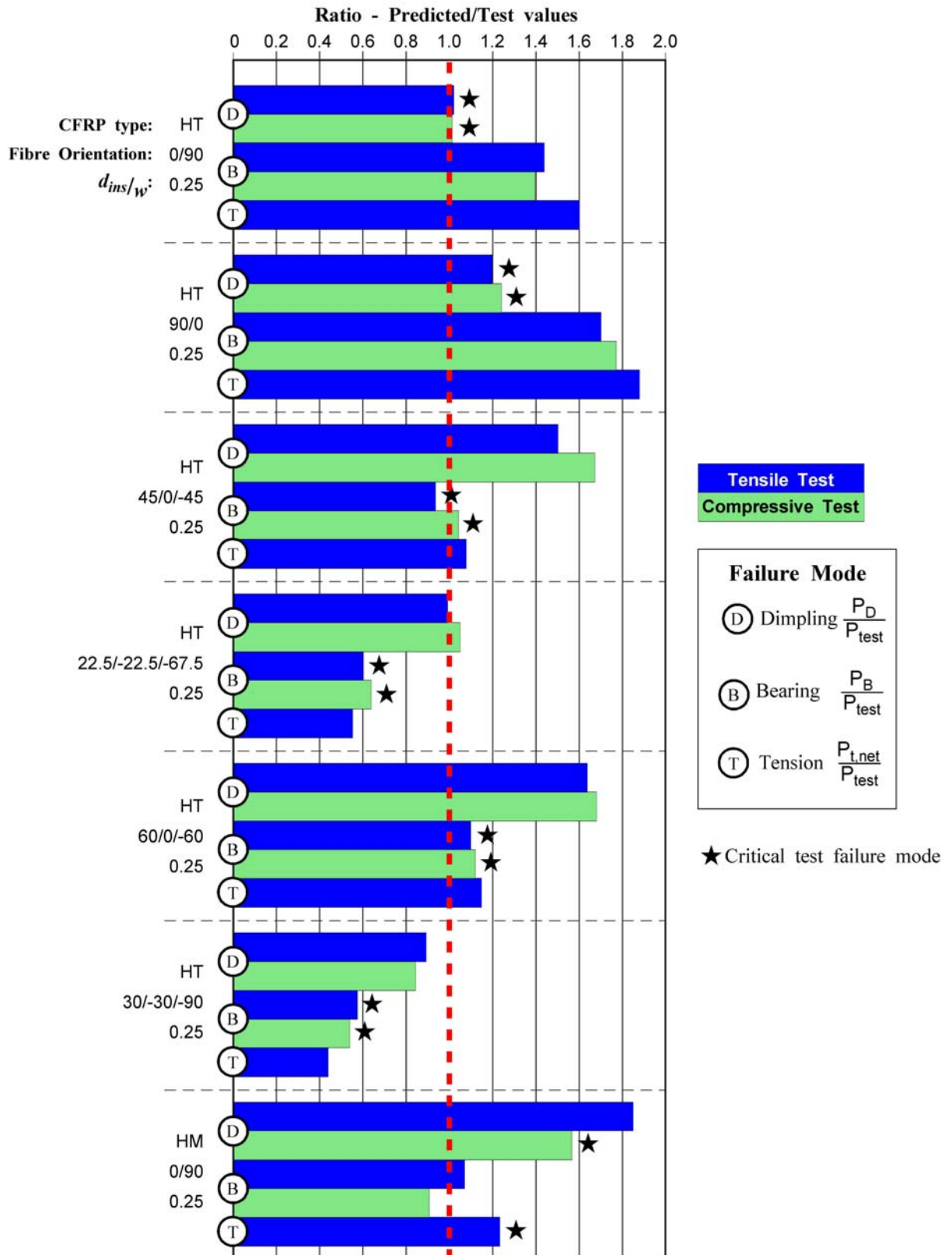

Figure 14-2: Correlation between calculated and tested in-plane capabilities with fibre orientation

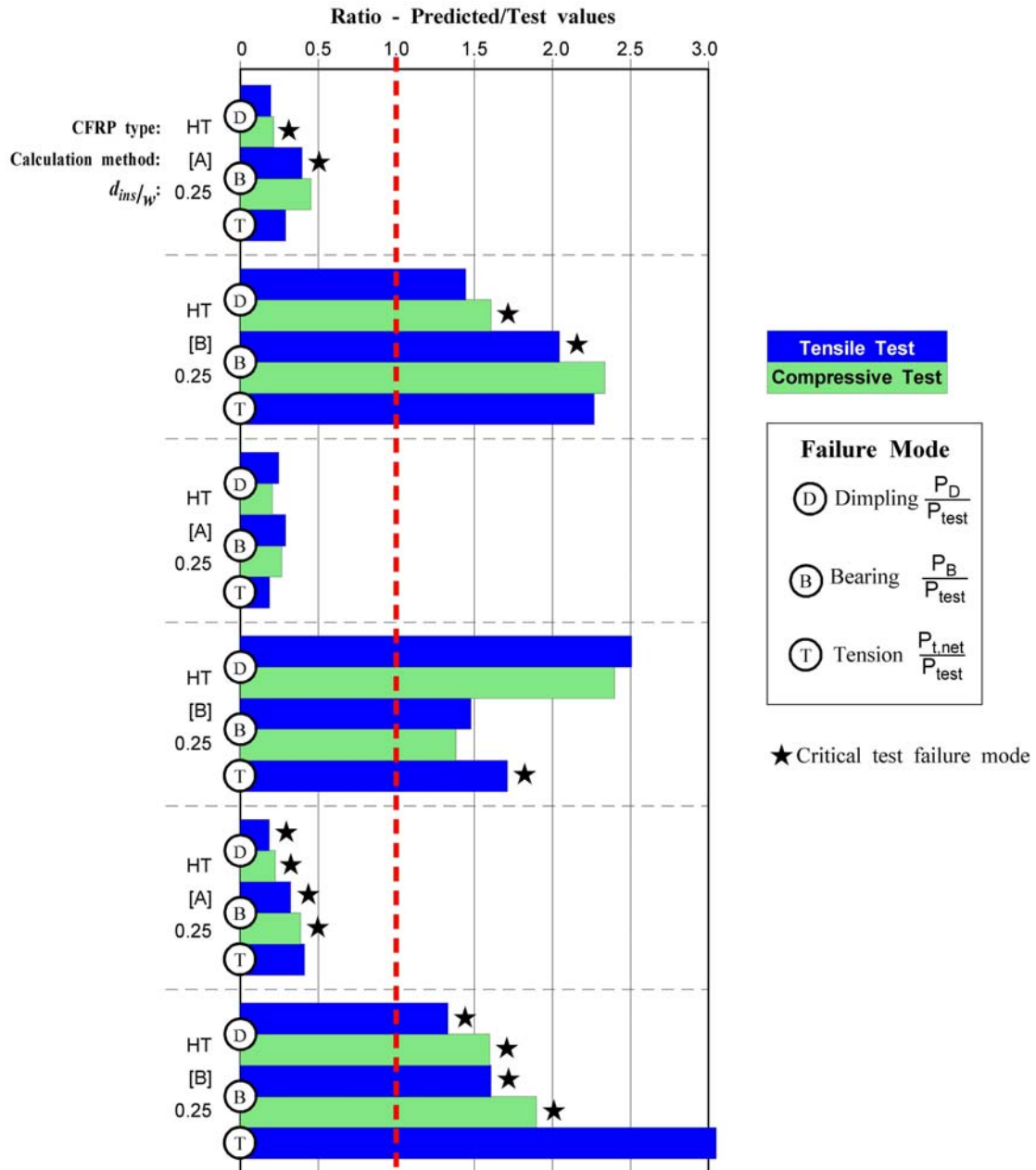

Figure 14-3: Correlation between calculated and tested in-plane capabilities with fibre strength

The in-plane load Q , applied to the insert is considered to act in the mid-plane of the upper face sheet. The diameter of the foot of the attached part should be at least as large as the typical potting diameter. A general design approach consists of four primary elements, where the capability of the sandwich-insert system is investigated with respect to the:

- Global stress acting as a remote stress in the area of the insert;
- Stress concentration imposed by the insert hole in the panel;
- In-plane loads loading the hole by bearing pressure, then
- Radial and circumferential stresses imposed by the load normal to the face sheet.

In addition, the effect of several inserts close to each other, their relative direction of loads as well as the effect of their distance from free boundaries taken into account in an approximate manner.

14.3.2 Face sheets

With a through-the-thickness insert, with symmetrical loads both face sheets, capabilities can be determined using the expression:

$$Q_{Stt_symm.} = 2(t_s b_p \sigma_{sy}) \quad [14.3-1]$$

where:

- t_s face sheet thickness,
- b_p potting radius,
- σ_{sy} yield strength of the face sheet.

For an unsymmetrical load case:

$$Q_{Stt_unsymm.} = 2t_s b_p \sigma_{sy} \quad [14.3-2]$$

In the partially potted case the core contribution should be taken into consideration by the semi-empirical expression:

$$Q_c = 8b_p^2 \tau_{Wcrit} \quad [14.3-3]$$

where:

- Q_c core contribution of in-plane load carrying capability.
- τ_{Wcrit} shear strength of core in W-direction.

The permissible shear load-carrying capability for a partially potted insert is given by:

$$Q_S = 8b_p^2 \tau_{Wcrit} + 2t_s b_p \sigma_{sy} \quad [14.3-4]$$

14.3.3 CFRP face sheets

14.3.3.1 Overview

At least four different failure modes of CFRP face sheets are possible under in-plane loads, [See also: Figure 6-3]:

- Tension;
- Shear-out;
- Dimpling;
- Bearing.

NOTE The analysis given applies to face sheets with 0°/90° fibre directions only.

14.3.3.2 Tension (net section)

The basic equation to establish the maximum in-plane load, Q_t against failure in tension is:

$$Q_t \leq \frac{1}{K_e'} (w - b_i) t_s \sigma_{t,ult} \quad [14.3-5]$$

where, [See: Figure 14-4 for nomenclature]:

- K_e' stress concentration factor depending upon b_i/w and e/w , [See: Figure 14-5];
- w panel width;
- b_i insert diameter;
- t_s face sheet thickness;
- $\sigma_{t,ult}$ ultimate tensile strength of face sheet;
- E edge distance.

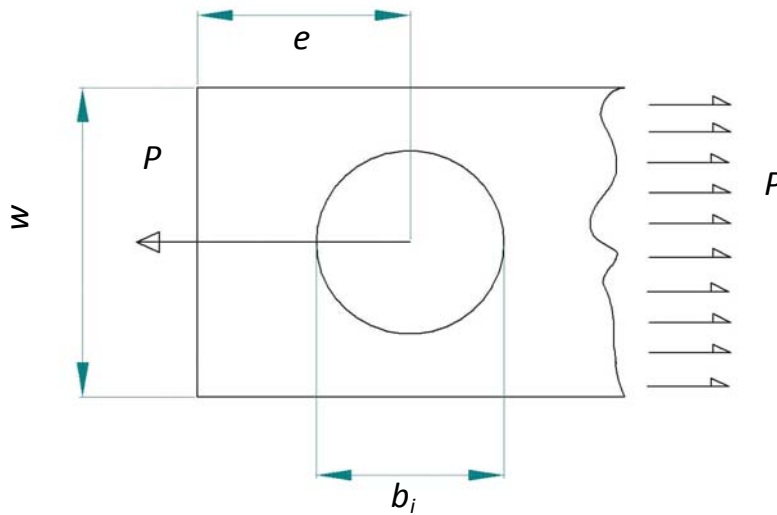

Figure 14-4: Nomenclature: Ultimate in-plane load against failure in tension

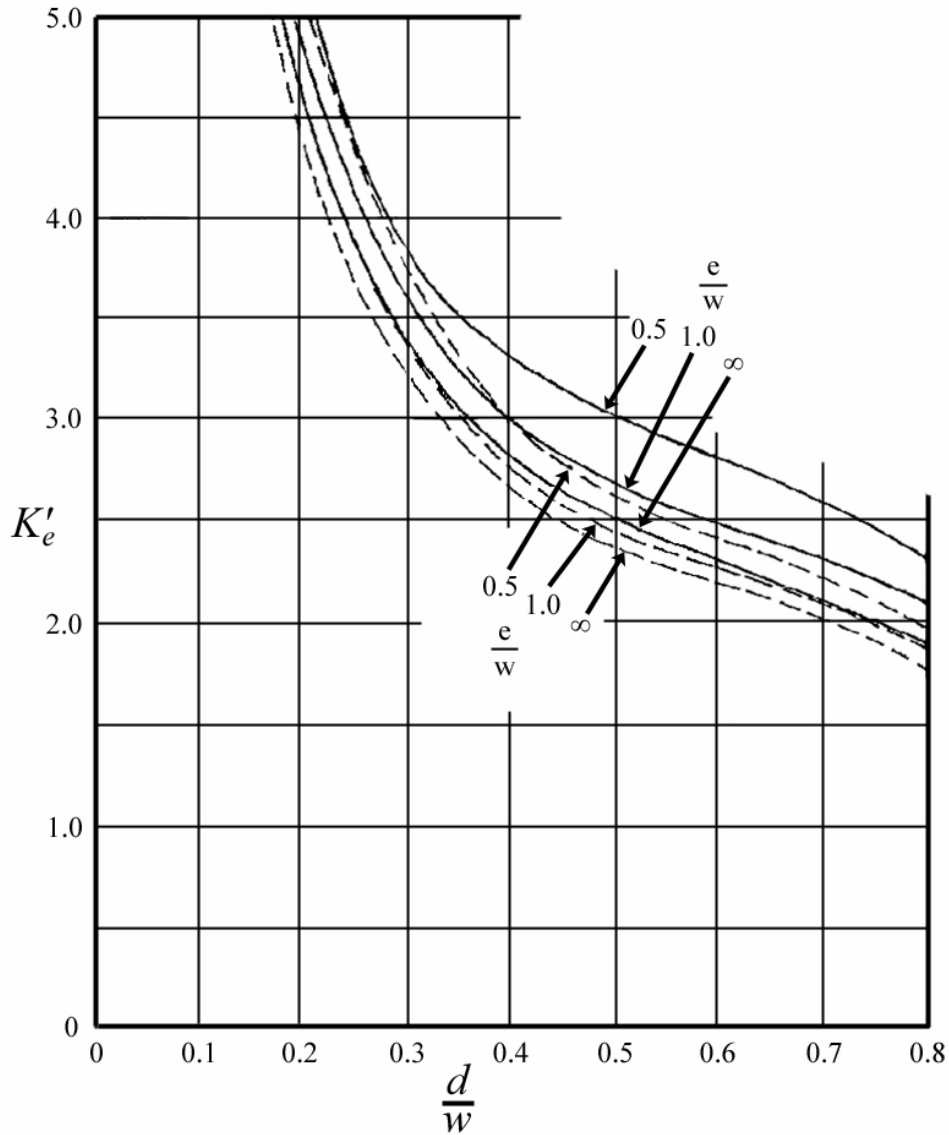

Figure 14-5: Shear strength: Stress concentration factor

14.3.3.3 Shear-out

The basic equation for the maximum in-plane load Q_t against shear out failure is:

$$Q_s \leq 2t_s \left(e - \frac{b_t}{2} \right) \frac{1}{\cos \alpha} \tau_s \quad [14.3-6]$$

Where, [See: Figure 14-6 for nomenclature].

- $\alpha \hat{=}$ angle of failure direction;
- $\tau_s \hat{=}$ in-plane shear strength of face sheet.

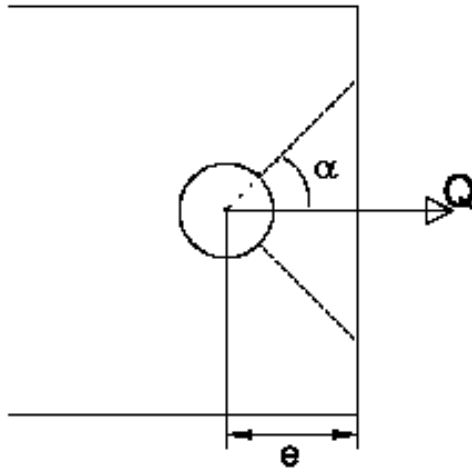

Figure 14-6: Shear strength: Failure angle

14.3.3.4 Dimpling

The maximum in-plane load at which dimpling of the sandwich face sheet occurs, shown in Figure 14-7, is given in the empirical expression:

$$Q_d \leq \frac{2}{\pi} b_p t_s K_D \frac{E_s}{1 - \nu_s^2} \left(\frac{t_s}{S_c} \right)^2 \quad [14.3-7]$$

where:

- b_p typical potting radius;
- t_s face sheet thickness;
- E_s Young's modulus of face sheet;
- ν_s Poisson's ratio of face sheet;
- S_c core cell size.
- K_D dimpling coefficient; which depends on the plate geometry, boundary conditions and type of loading.

The analysis of test data gave a value of K_D of 2.0. Whereas from Figure 14-7, it can be concluded that a constant value of $K_D = 2.0$ is not supported by test results in the whole range of t_s/S_c .

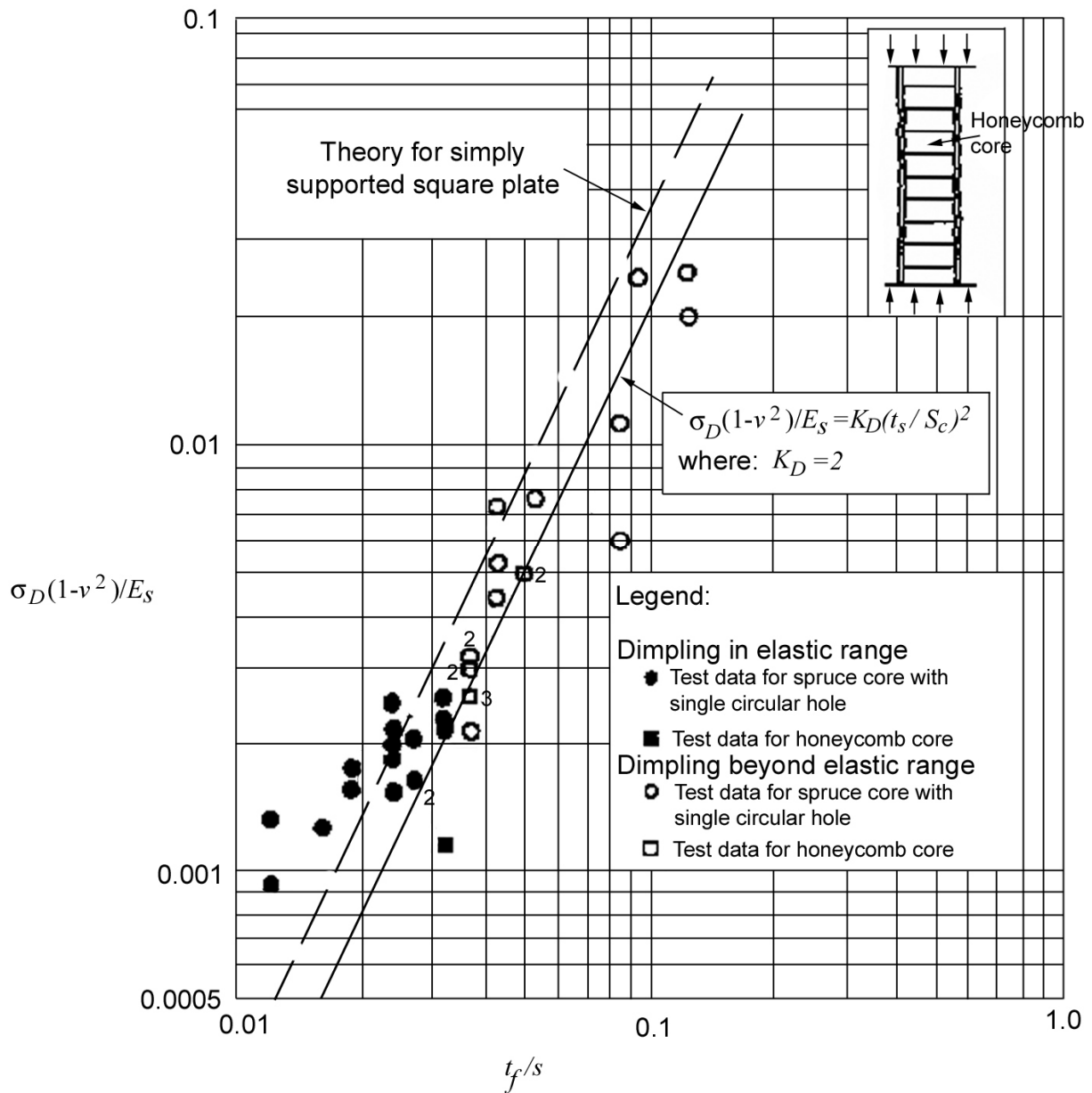

Figure 14-7: Shear strength: Critical stresses for intracellular buckling (dimpling) under uniaxial compression

14.3.3.5 Bearing

The basic equation for the maximum in-plane load Q_i against bearing failure is:

$$Q_b \leq K_b \frac{2}{\pi} b_i t_s \sigma_{comp} \quad [14.3-8]$$

where:

K_b	coefficient which depends on: panel geometry and stress introduction; Based on previous tests the K_b value of 2.2 was chosen.
B_i	insert diameter;
t_s	face sheet thickness;
σ_{comp}	ultimate compression strength of the face sheet.

14.3.4 Effect of panel layout

14.3.4.1 Edge influence

The reduced load-carrying capability of inserts under in-plane loading that are located at a free panel edge can be expressed by:

$$Q_{crit}^* = Q_{crit} \eta_{EQ} \quad [14.3-9]$$

where:

Q_{crit}^*	insert capability under shear load, reduced by edge influence;
Q_{crit}	initial shear capability of insert;
η_{EQ}	edge coefficient for shear loaded insert.

For metallic face sheets:

$$\eta_{EN} = 0.66 \sqrt{\frac{e}{b_p}} - 0.06 \frac{e}{b_p} \quad \text{for } e \leq 3b_p \quad [14.3-10]$$

$$\text{and: } \eta_{EN} = 1 \text{ for } e > 3b_p$$

where:

e	distance between insert centre and panel edge;
b_p	potting radius of insert.

The edge coefficient η_{EQ} is plotted against the relative edge distance, e/b_p in Figure 14-8.

Owing to the complicated nature of fibre-reinforced composites, it can be concluded that tests are necessary to obtain reliable data for edge coefficients.

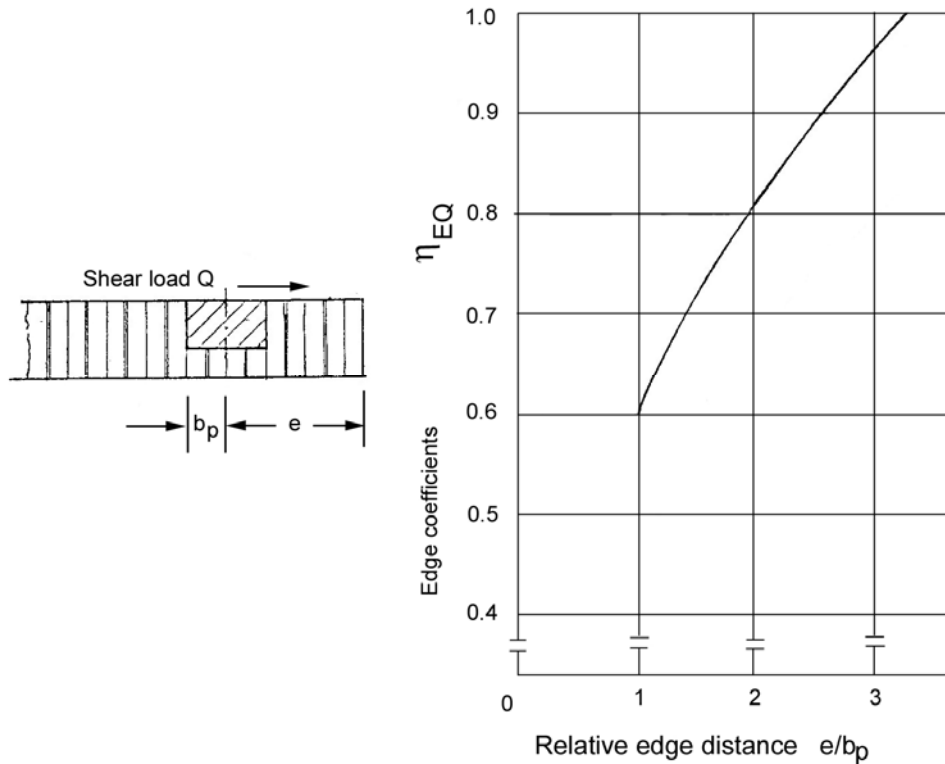

Figure 14-8: Shear strength: Influence of edge distance

14.3.5 Sensitivity of insert strength in face sheets

Table 14-1 gives the sensitivity of each component in in-plane cases, according to (Eqn. [14.3-4]), i.e.:

$$Q_S = 8b_p^2 \tau_{w\text{crit}} + 2t_s b_p \sigma_{sy} \quad [14.3-11]$$

The sensitivity is calculated for a 5% deviation of each component. The contributions of the different components are shown in Figure 14-9.

Table 14-1: In-plane capability: Effect of components on core shear

	Original values		+5% values		Increase	Influence
	(N)	(N)	(N)	(N)		
b_p	11.42 mm	3097	11.99 mm	3311	214	6.91
σ_{sy}	289.00 mm	3097	303.45 mm	3196	99	3.20
τ_w	1,07 MPa	3097	1.12 MPa	3153	56	1.81
t_s	0.3 mm	3097	0.32 mm	3196	99	3.20

NOTE Example case: D17, 3/16-0.001P, $c = 30$ mm, $t_s = 0.3$ mm. Partially potted. Failure mode: Core shear.

Sensitivity of In-plane

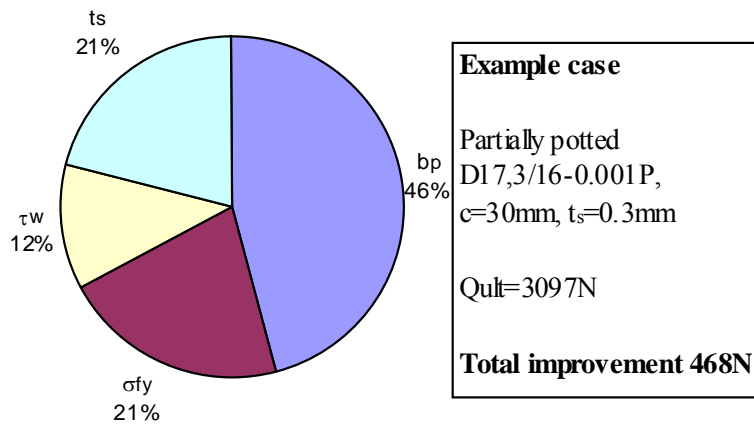

Figure 14-9: In-plane capability: Contributions of the main components on improved core shear

14.3.6 Effect of thin CFRP face sheet

The advantages related to the design can be affected when applied to inserts in sandwich panels with thin CFRP face sheets, [See also: Clause 9; 10.2; 10.9].

When in-plane load is applied on an insert, the load is by bearing pressure in the face sheet. The support of the CFRP face sheet by the clamping force, created between the potting and bracket by the pre-load on insert bolt, can be affected by one or the combination of several slight tolerances between the elements involved, i.e.:

- The insert can be potted slightly too low, such that the area enabling the transfer of bearing pressure is reduced or is insufficient
- The capability to transfer in-plane loads by bearing can become dependent on the sharpness of the insert flange.
- The finishing of protruding inserts after potting can be deleterious with respect to damage of thin CFRP laminates.
- Slippage between the brackets and face sheet, e.g. under vibration loads, can damage the surfaces of the CFRP face sheets.
- Non-perfect parallel planes in the contact area can result in local gaps such that the intended support around the insert hole is not achieved.

Under such conditions it is not clear if the advantages of the design can be maintained with very thin CFRP face sheets.

14.4 References

14.4.1 General

- [14-1] Lassi Syvänen, Kari Marjoniemi, Ari Ripatti, Markku Pykäläinen: Patria Finaviacomp Oy, Finland

'Analysis models for insert design rules in sandwich panels with CFRP facings'

Patria report: GS1-PFC-RP-0002 (January 2003)

ESTEC Contract No. 14076/99
- [14-2] W. Hertel, W. Paul & D. Wagner

'Standardisation program on design, analysis and testing of inserts'

Final report ESA CR(P)-1498, February 1981

15 Bending strength

15.1 Bending load

In general, subjecting inserts to bending loads is not advisable; as shown in Figure 15-1.

Where it cannot be avoided, e.g. by using coupled inserts that convert the load to tension or compression, the diameter D of the foot of the attached part should be at least as large as the potting diameter $2b_p$, i.e. as for shear-loaded inserts.

[See also: 14.1] For inserts in non-metallic cores, the bending capability determined by this method is considered as an estimate possibly for preliminary design purposes.

Standard partially- and fully-potted inserts are covered by the design rules given here. For through-the-thickness inserts, an alternative load path exists which normally makes such inserts significantly stronger for this loading application, [See: 15.2].

[See also: A.3 and F.6 for non-standard inserts]

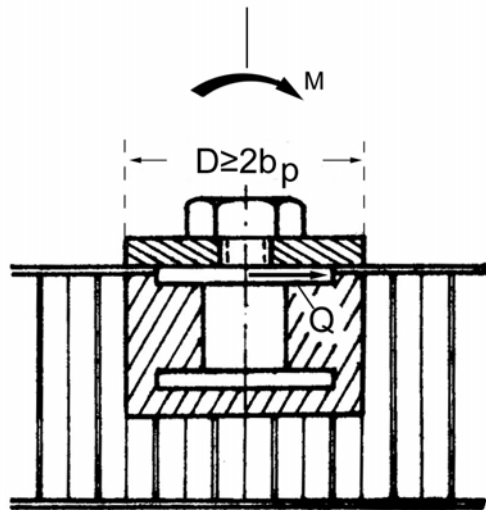

Required clamping

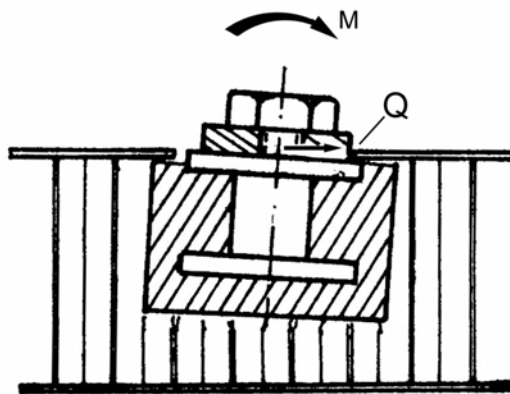

Fixture to be avoided

Figure 15-1: Inserts loaded in bending: Clamping conditions

15.2 Permissible bending load

The design rules discussed here cover standard partially- and fully-potted inserts. Through-the-thickness inserts have an alternative load path that normally makes such inserts significantly stronger, [See also: 15.1].

The design should preclude the head of an insert from 'submarining' under the panel face sheets.

The insert body, and any fasteners used, should be capable of transferring the loads into the two face sheets, i.e. the bending allowable = min. ($D_1 \times$ shear allowable face sheet 2, $D_1 \times$ shear allowable face sheet 1); as shown schematically in Figure 15-2.

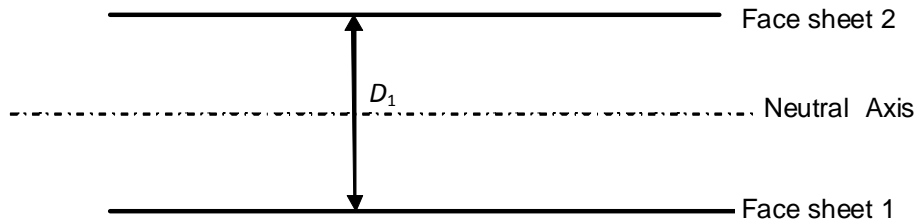

Figure 15-2: Bending load: Schematic of load-transfer

It is based upon the premise that the sum of the load in face sheet 1 plus face sheet 2 is zero for a pure moment. The allowable is therefore dependent upon the weakest face sheet, [See: 14.2].

In the case of a moment plus a shear load, the moment adds to the shear on one side and subtract from the shear on the other face. Depending upon the relative strengths of the two face sheets and the loading conditions, the added shear load can increase or decrease the permitted moment.

Under the conditions given in 15.1, the permissible bending load, M_{ss} to which the insert can be subjected is given by:

$$M_{ss} = P_{SSc} b_i \quad [15.2-1]$$

were:

P_{SSc} permissible compressive loads, [See: 13.2].

b_i radius of insert.

15.3 Composite face sheet

Inserts are considered to be very sensitive to bending, so every attempt is made to avoid such conditions in a design, i.e. moments are reacted by groups of inserts, [15-1].

An expression used to assess the effect of secondary bending, is:

$$M_{crit} = P_{crit} b_i \quad [15.3-1]$$

Where:

P_{crit} critical out-of-plane load;

b_i insert (hole) diameter.

This expression does not take into account coupling of the potting on the lower face sheet and becomes more conservative for a fully potted insert.

It is also possible to obtain a higher critical bending moment, M_{crit} by using a larger footprint insert, as shown in Figure 15-3.

Owing to the complexity of CFRP face sheets, bending moments should be carried by a couple of inserts.

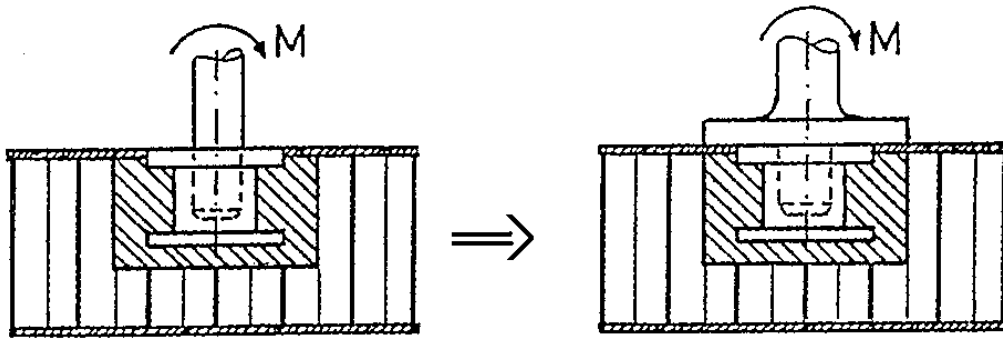

Figure 15-3: Bending load: Insert footprint on moment loading

Although CFRP face sheets are complex, the situation is generally somewhat similar to metallic face sheets, whereby torsion and bending moments are carried by a couple of inserts.

[See also: 10.2]

15.4 References

15.4.1 General

- [15-1] Lassi Syvänen, Kari Marjoniemi, Ari Ripatti, Markku Pykäläinen: Patria Finaviacomp Oy, Finland
 'Analysis models for insert design rules in sandwich panels with CFRP facings'
 Patria report: GS1-PFC-RP-0002 (January 2003)
 ESTEC Contract No. 14076/99

16

Torsional strength

16.1 Torsional load

Like bending loads, torsional loads on single inserts are avoided by using coupled inserts, [See: 15.1]. If this is not possible, the diameter D of the foot of the attached part should be at least as large as the potting diameter, i.e. $D \geq 2(b_i + 4 \text{ mm})$.

[See also: Figure 14-1][See also: 16.3 for composite face sheets]

16.2 Permissible torsion load

16.2.1 General

The most unfavourable case is a shear rupture of the cell walls enclosing the potting, without any load participation by other parts of the sandwich-insert combination, [See also: 16.3].

16.2.2 Metallic core

The shear strength of the cell walls is that of the foil material, e.g.:

- For 5052 H38: $\tau_{0 \text{ crit}} = 180 \text{ N/mm}^2$
- For 5056 H38: $\tau_{0 \text{ crit}} = 220 \text{ N/mm}^2$

The maximum torsion load, T_{SS} , which a single insert in a metallic core can support is given by:

$$T_{SS} = 4\pi b_R^2 t_0 \tau_{0 \text{ crit}} \quad [16.2-1]$$

were:

b_R real potting radius, [See: Table 12-2]. t_0 core foil thickness, [See: Table 6-3].

NOTE Although minimum, average and typical values are stated, minimum values are applied.

16.2.3 Non-metallic core

It is advised to determine the permissible torsion load of inserts in non-metallic cores by test.

16.3 Composite face sheets

Torsion loads on inserts is usually minimised by placing groups of them in the panel.

Owing to the deformation or installation of the connecting bolt, torsional loads cannot always be totally avoided. Under these circumstances, an expression that can be used is:

$$T_{crit} = 4\pi b_R^2 t_0 \tau_{0_{crit}} \quad [16.3-1]$$

where:

- b_R real potting radius,
- t_0 foil thickness of core,
- τ_{crit} shear strength of core material.

[See also: Figure 16-1 for nomenclature]

Owing to the complexity of CFRP face sheets, torsional moments are carried collectively by several inserts.

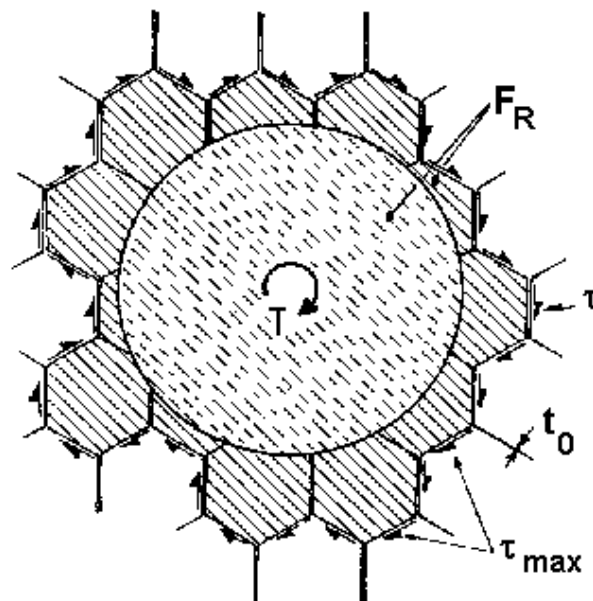

Figure 16-1: Torsional load: Nomenclature

Although CFRP face sheets are complex, the situation is generally somewhat similar to metallic face sheets, whereby torsion and bending moments are carried by a couple of inserts.

[See also: 10.2]

16.4 References

16.4.1 General

- [16-1] Lassi Syvänen, Kari Marjoniemi, Ari Ripatti, Markku Pykäläinen: Patria Finaviacomp Oy, Finland
- ‘Analysis models for insert design rules in sandwich panels with CFRP facings’
- Patria report: GS1-PFC-RP-0002 (January 2003)
- ESTEC Contract No. 14076/99

17

Combined loads

17.1 Inclined load

The most common load combination is the inclined load F which is a combination of a normal load P (tensile or compressive) and a shear load Q , as shown in Figure 17-1.

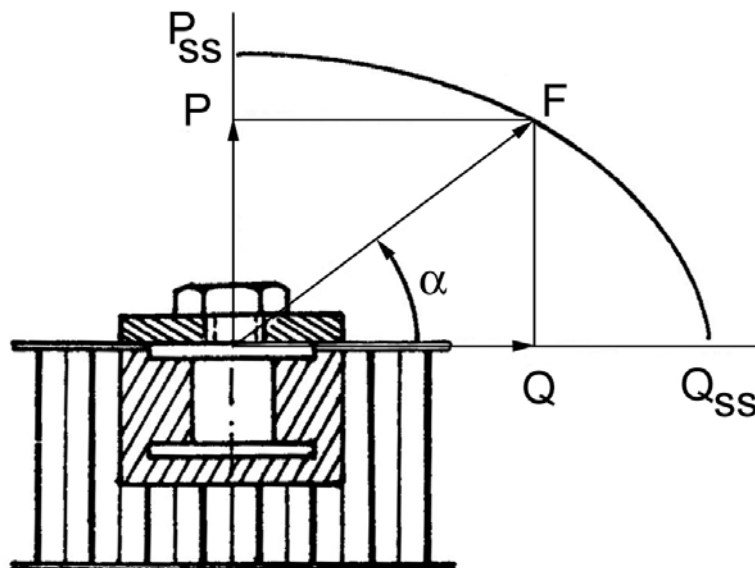

Figure 17-1: Insert submitted to an inclined load

where:

- $P = F \sin \alpha$ component in normal (out-of-plane) direction;
- $Q = F \cos \alpha$ component in shear (in-plane) direction;
- F applied inclined or angle load;
- α angle between applied load F and sandwich plane.

With known components Q and P , it is shown that:

$$\left(\frac{P}{P_{SS}}\right)^2 + \left(\frac{Q}{Q_{SS}}\right)^2 \leq 1 \quad [17.1-1]$$

With given angle of resultant, the allowable F_{SS} becomes:

$$|F_{SS}| = \frac{P_{SS}Q_{SS}}{\sqrt{P_{SS}^2 \cos^2 \alpha + Q_{SS}^2 \sin^2 \alpha}} \quad [17.1-2]$$

where:

- P_{SS} permissible tensile or compressive load, [See: 12.5 tensile; 13.2 – compression]
- Q_{SS} permissible shear load, [See: 14.2; Eqn. [14.2-1].

17.2 General load combinations

The load conditions describe an insert submitted simultaneously to:

- Normal (tensile or compressive) load, P ;
- Shear (in-plane) load, Q ;
- Bending moment, M ;
- Torsional moment, T .

Partially- and fully-potted inserts are covered by these design guidelines. For through-the-thickness inserts, the shear and moment components should be resolved into one shear component prior to calculation, i.e. the single shear component, $Q =$ shear component in the face sheet from applied shear + shear component resulting from reacting the applied moment.

Thereby Q_{SS} becomes the shear permissible load for the calculated face sheet. Both face sheets are calculated and the sheet with the lowest value of Q_{SS}/Q is then used in Eqn. [17.2-1].

- Shear (in-plane) load, Q ;
- Bending moment, M ;
- Torsional moment, T .

Partially- and fully-potted inserts are covered by these design guidelines. For through-the-thickness inserts, the shear and moment components should be resolved into one shear component prior to calculation, i.e. the single shear component, $Q =$ shear component in the face sheet from applied shear + shear component resulting from reacting the applied moment.

[17.2-1]

Thereby Q_{SS} becomes the shear permissible load for the calculated face sheet. Both face sheets are calculated and the sheet with the lowest value of Q_{SS}/Q is then used in Eqn. [17.2-1].

$$\left(\frac{P}{P_{SS}}\right)^2 + \left(\frac{Q}{Q_{SS}}\right)^2 + \left(\frac{M}{M_{SS}}\right)^2 + \left(\frac{T}{T_{SS}}\right)^2 \leq 1$$

where:

- P_{SS} permissible tensile or compressive load, [See: 12.5 tensile; 13.2 – compression]
- Q_{SS} permissible (in-plane) shear load, [See: 14.2; Eqn. [14.2-1]. For through-the thickness inserts, the value of Q_{SS} is the lowest value determined for each face sheet.
- M_{SS} bending permissible load, [See: 15.2; Eqn. [15.2-1].
- T_{SS} torsion permissible load, [See: 16.2; Eqn. [16.2-1]. Bending and torsion loads need to be covered by adequate design, e.g. by large footprints, groups of inserts, [See also: 15.1; 16.1]



An adequate 'margin of safety' should be fully considered and applied to variables.

18

Edge influence

18.1 Edge distance: Out-of-plane loading

The distance between the centre line of an insert and the edge of the sandwich panel is known as the edge distance, e . The edge distance effect for out-of-plane loading is largely core dependent.

The edge of a sandwich panel can be either free, i.e. without any form of closure, or closed, i.e. with some form of close-out or edge member. The effect on the load-bearing capacity of the insert, presented here, applies to free edges only. For sandwich panels with an edge close-out, the edge coefficient is 1.

If two inserts are placed close to each other that their effective potting radii are almost together, then the two inserts behave as one.

The reduced load-carrying capacity of inserts located close to a free panel edge, can be expressed by:

$$P_{SS}^* = P_{SS} \eta_{EN} \quad [18.1-1]$$

Where:

P_{SS}^* insert capability under normal load, reduced by edge influence.

P_{SS} initial capability of insert, [See: 19.1; 19.2].

η_{EN} edge coefficient, for normally loaded inserts.

The edge coefficient, η_{EN} is determined by:

$$\begin{aligned} \eta_{EN} &= 0.55 \sqrt{\frac{e}{b_p}} - 0.05 \quad \text{for } e \leq 5b_p \\ \eta_{EN} &= 1 \quad \text{for } e > 5b_p \end{aligned} \quad [18.1-2]$$

NOTE For sandwich panels with close-outs, $\eta_{EN} = 1$.

Provided that the close-out material, has some minimal degree of stiffness.

where:

e distance between insert centre and panel edge.

b_p potting radius of insert.

NOTE An edge distance cannot be smaller than b_p ($e < b_p$).

The edge coefficient for normally loaded inserts, η_{EN} , is plotted as a function of the relative edge distance e/b_p in Figure 18-1.

[See also: 18.2 for edge coefficients, η_{EQ} for shear-loaded inserts; 18.3 for composite face sheets

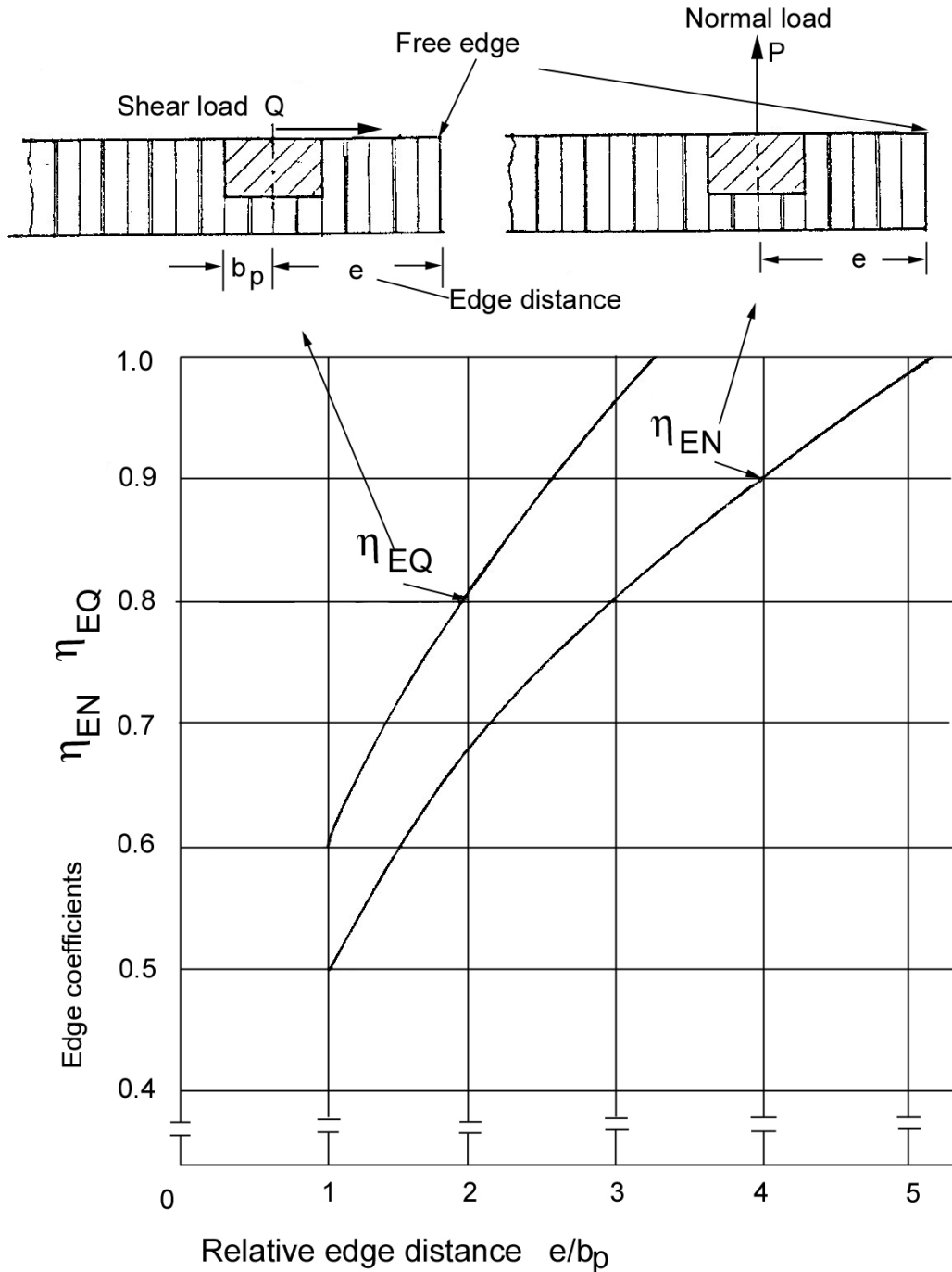

Figure 18-1: Edge distance: Effect on insert static strength capability

18.2 Edge distance: Shear loaded

18.2.1 General

The edge of a sandwich panel can be either free, i.e. without any form of closure, or closed, i.e. with some form of close-out or edge member. The effect on the load-bearing capacity of the insert,

presented here, applies to free edges only. For sandwich panels with a close-out on the edge, the edge coefficient is 1, [See also: 18.1 for normally-loaded inserts, η_{EN} values].

Investigation of stress concentrations of shear (in-plane) loaded metallic structures has shown that severe interactions between two or more holes exist. This is especially true when the holes considered are:

- 'Pin loaded holes' located close to a sandwich panels edge. or
- Several adjacent holes are loaded in different load directions.

This results in a combined stress distribution, i.e. combined panel stress, hole stress and pin-loading.

The reduced load-carrying capacity of inserts under shear loading located close to a free panel edge, can be expressed by:

$$Q_{SS}^* = Q_{SS} \eta_{EQ} \quad [18.2-1]$$

where:

Q_{SS}^* shear-load capability of the insert, reduced due to the proximity of the panel edge.

Q_{SS} initial shear load capability of insert, [See: 14.1]

η_{EQ} edge coefficient for shear-loaded inserts.

[See: Figure 18-1 for edge coefficients (η_{EQ}) of shear-loaded inserts]

18.2.2 Metallic face sheets

$$\eta_{EQ} = 0.66 \sqrt{\frac{e}{b_p}} - 0.06 \frac{e}{b_p} \quad \text{for } e \leq 3b_p$$

$$\eta_{EQ} = 1 \quad \text{for } e > 3b_p \quad [18.2-2]$$

NOTE For sandwich panels with close-outs, $\eta_{EQ} = 1$.

where:

e distance between insert centre and panel edge.

b_p potting radius of insert.

NOTE An edge distance cannot be smaller than b_p ($e < b_p$).

18.2.3 Non-metallic face sheets

[See: 18.3]

18.3 Composite face sheets

18.3.1 Out-of-plane loading

[See also: 18.1]

Two inserts can be placed close to each other so that their effective potting radii are almost together. If both inserts are loaded by out-of-plane loads, shear forces cannot be created in the adjacent cell walls. In this case, these two inserts act as one. The edge distance effect for an out-of-plane loaded insert is primarily related to the core used.

Therefore, the edge distance effect can be considered relevant for sandwich panels with CFRP face sheets, [18-1]

18.3.2 In-plane loaded inserts

[See also: 18.2]

Based on the investigation of stress concentrations for the case of in-plane loaded metallic structures, it is known that severe interactions between two or more holes exist, [18-1]. This is especially true when the holes considered are:

- 'pin loaded holes' located close to a sandwich panels edge, or
- several adjacent holes are loaded in different load directions.

The global stress of the panel, the stress concentration effect of the insert hole and the local stresses induced by the insert (pin-) load are combined. In the case of several adjacent inserts, the situation is more complex.

CFRP face sheets have a brittle failure behaviour, sometimes with a damage tolerance of an equivalent hole of between 3 mm and 5 mm. This is not always serious with respect to the in-plane load capability of an insert, but implementation of an insert can result in a total failure of the panel itself.

A CFRP panel can not be adequately designed without reflecting such effects. They are highly relevant with respect to the correct superposition of local stress failure criteria which are valid for CFRP.

Owing to the complicated nature of CFRP composites, it can be concluded that tests are necessary to obtain reliable data for edge coefficients.

18.4 References

18.4.1 General

- [18-1] Lassi Syvänen, Kari Marjoniemi, Ari Ripatti, Markku Pykäläinen: Patria Finaviacomp Oy, Finland
 'Analysis models for insert design rules in sandwich panels with CFRP facings'
 Patria report: GS1-PFC-RP-0002 (January 2003)
 ESTEC Contract No. 14076/99

19

Insert groups

19.1 Two inserts: Loaded in same direction

19.1.1 General

If two adjacent inserts are simultaneously loaded in the same direction, the static strength capability of each insert is reduced by the stress field of the other insert, according to:

$$P_{SS1}^* = \eta_{IS1} P_{SS1} \quad [19.1-1]$$

Where:

P_{SS1}^* reduced capability of insert 1, due to insert 2.

P_{SS1} initial capability of insert 1, without influence of insert 2.

Depending on their distance apart, the interference effect of one insert on the other can be considered as either:

- Close, or
- Distant.

[See also: 19.2; 19.3]

19.1.2 Close inserts

If the distance between the inserts, a , does not exceed:

$$a \leq 5(b_{p1} + b_{p2}) \quad [19.1-2]$$

η_{IS1} interference coefficient of insert 1, when simultaneously loaded in the same direction as insert 2:

$$\eta_{IS1} = \frac{b_{p1}/b_{p2}}{1 + b_{p1}/b_{p2}} \left(1 + \frac{a}{5b_{p1}} \frac{1}{1 + b_{p1}/b_{p2}} \right) \quad [19.1-3]$$

where:

b_{p1} potting for insert 1.

b_{p2} potting radius for insert 2.

a centre-to-centre distance between inserts.

[See also: Figure 19-1]

19.1.3 Distant inserts

If the distance between the inserts, a , exceeds:

$$a > 5(b_{p1} + b_{p2})$$

Then, the mutual influence of both inserts is negligible, i.e.:

$$\eta_{IS1} = \eta_{IS2} = 1 \quad \text{for } a > 5(b_{p1} + b_{p2}) \quad [19.1-4]$$

Where:

η_{IS2} interference coefficient of insert 2, when simultaneously loaded in the same direction as insert 1:

$$= \frac{\left(\frac{b_{p1}}{b_{p2}}\right)^{-1}}{1 + \left(\frac{b_{p1}}{b_{p2}}\right)^{-1}} \left[1 + \frac{a}{5b_{p1}} \left[\frac{b_{p1}}{b_{p2}} \right]^{-1} \right] \quad [19.1-5]$$

Insert 2's reduction of the capability of insert 1, given by η_{IS1} , is only fully effective if insert 2 is itself loaded up to its own capability:

$$P_{SS2}^* = \eta_{IS2} P_{SS2} \quad [19.1-6]$$

where:

P_{SS2}^* reduced capability of insert 2, due to insert 1.

19.1.4 Effect of load

If insert 2 is submitted to an actual load P_2 that is lower than the reduced load capability P_{SS2}^* of this insert, the reducing influence on insert 1 is smaller.

The load capability reduction of insert 1 is then given by:

$$\eta_{IS1}^I = 1 - \left(1 - \eta_{IS1}\right) \frac{P_2}{P_{SS2}^*} \quad [19.1-7]$$

This case can be relevant if both inserts are not simultaneously loaded up to their respective, reduced capabilities P_{SS1}^* and P_{SS2}^* .

In Figure 19-1, η_{IS1} and η_{IS2} are plotted as a function of the relative insert distance a/b_{pi} ; where the parameter is the ratio of potting radii b_{p1}/b_{p2} .

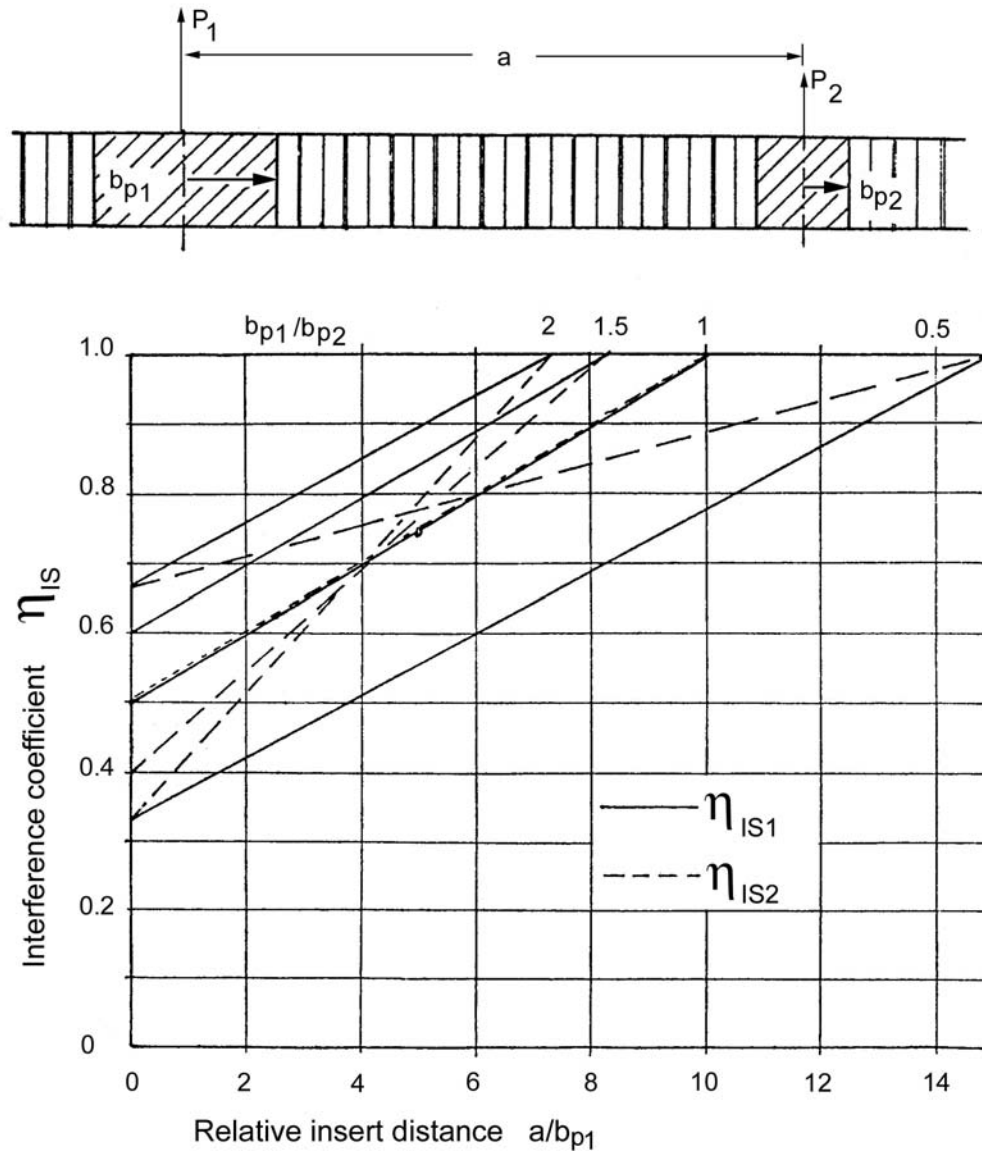

Figure 19-1: Insert groups: Reduced insert capability - two adjacent inserts loaded in the same direction

19.2 Two inserts: Loaded in opposite directions

19.2.1 General

If two adjacent inserts are simultaneously loaded in opposite directions, i.e. $P_1 = -P_2$, the static strength capability of each insert is only slightly reduced by the stress field of the other insert.

Depending on their distance apart, the interference effect of one insert on the other can be considered as either:

- close, or
- distant.

For design purposes, the reduced capability of two inserts loaded in opposite directions is given by:

$$P_{SS}^* = P_{SS} \eta_{IC} \quad [19.2-1]$$

where:

P_{SS}^* capability of insert 1 reduced by the insert 2.

P_{SS} initial capability of a single insert

η_{IC} interference coefficient for opposite loading.

[See also: 19.1; 19.3]

19.2.2 Close inserts

In Eqn. [19.2-1]:

$$\eta_{IC} = 0.9 \quad \text{for} \quad a \leq 5(b_{p1} + b_{p2})$$

[See also: Figure 19-1 for geometric configuration]

19.2.3 Distant inserts

In Eqn. . [19.2-1]:

$$\eta_{IC} = 1.0 \quad \text{for} \quad a > 5(b_{p1} + b_{p2})$$

[See also: Figure 19-1 for geometric configuration]

19.3 Series of inserts: Loaded in same direction

19.3.1 Overview

The effect on capability for a series of inserts is considered for:

- First and last inserts, and
- Intermediate inserts.

This is illustrated by an example.

19.3.2 First and last inserts

The first and last inserts in a series are primarily influenced by only one adjacent insert; as shown in Figure 19-2.

The reduced capability is determined by Eqn. [19.1-1], [See: 19.1], i.e.:

$$P_{SS1}^* = P_{SS1} \eta_{IS1}$$

where:

P_{SS1}^* capability of first or last insert reduced by second or last but one insert

P_{SS1} initial capability of first or last insert

η_{ISl} interference coefficient of first or last insert related to the second or last but one insert, [See: 19.1; Eqn. [19.1-2]].

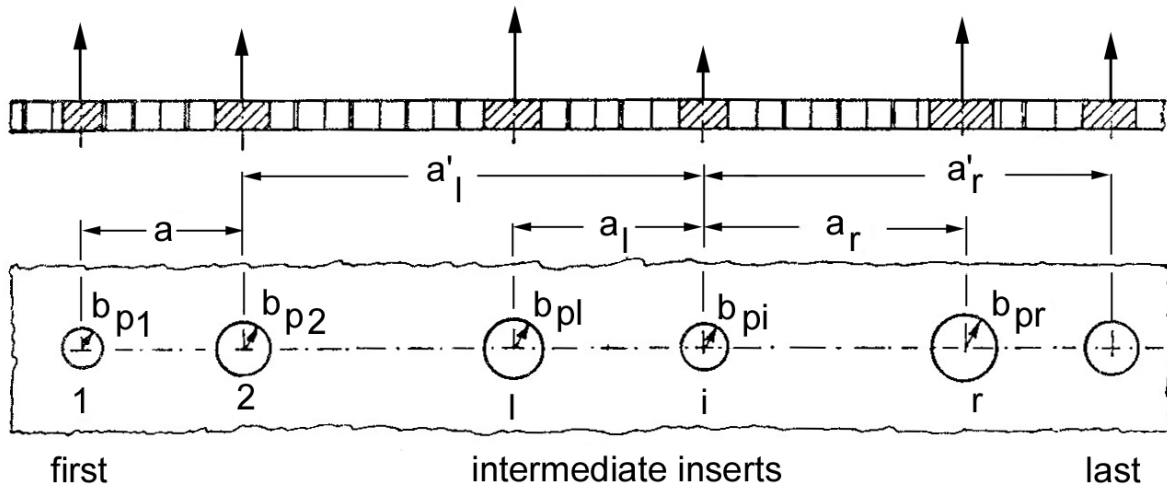

Figure 19-2: Insert groups: Series of inserts loaded in same direction

19.3.3 Intermediate inserts

The intermediate inserts, i are primarily influenced by the insert immediately to their left, l and right, r . Their reduced capability is:

$$P_{SSi}^* = P_{SSi} (\eta_{ISl} + \eta_{ISr} - 1) \quad [19.3-1]$$

where:

- P_{SSi}^* capability of intermediate insert influenced by both adjacent inserts.
- P_{SSi} initial capability of intermediate insert.
- η_{ISl} interference coefficient of intermediate insert related to left insert; [See: Eqn. 19.1; [19.1-2]], with:
 - b_{p1} = potting radius of intermediate insert,
 - b_{p2} = potting radius of left insert, and
 - $a = a_l$ = distance between the centres of intermediate and left insert.
- η_{ISr} interference coefficient of intermediate insert related to the right insert; [See: 19.1; [19.1-2]], with:
 - b_{p1} = potting radius of intermediate insert,
 - b_{p2} = potting radius of right insert, and
 - $a = a_r$ = distance between the centres of intermediate and right insert.

19.3.4 Example

Determination of the insert capability for a configuration where:

- Series of 5 equal inserts;
- Equal potting radius b_p for all inserts;
- Equal insert distance $a = 6b_p$.

19.3.4.1 Interference coefficient

From Figure 19-1, the interference coefficient corresponding to $b_{p1}/b_{p2} = 1$ and $a/b_{p1} = 6$ is identical for all inserts, i.e.:

$$\eta_{IS1} = \eta_{ISl} = \eta_{ISr} = 0.8$$

19.3.4.2 Static strength

The static strength capabilities are then:

$$P^*_{SS1} = 0.8 P_{SS} \quad \text{for inserts 1 and 5.}$$

$$P^*_{SSi} = P_{SS}(0.8 + 0.8 - 1) = 0.6 P_{SS} \quad \text{for inserts 2, 3 and 4.}$$

where:

$$P_{SS} \quad \text{initial static strength capability of the used insert.}$$

19.3.4.3 Validation

These formulae are considered valid if the distance a' between the insert and its neighbour is large enough, i.e.

$$a' \geq 5(b_{pi} + b_{pi\pm 2}) \quad [19.3-2]$$

Otherwise, the next-but-one insert also influences the insert considered.

In this case, the total capability of the series $\sum P^*_{SS}$ (as determined by the formulae cited) remains valid, whereas the distribution of the load over the inserts is incorrect.

19.4 Series of inserts: Loaded in opposite directions

19.4.1 Overview

Figure 19-3 shows the loading configuration.

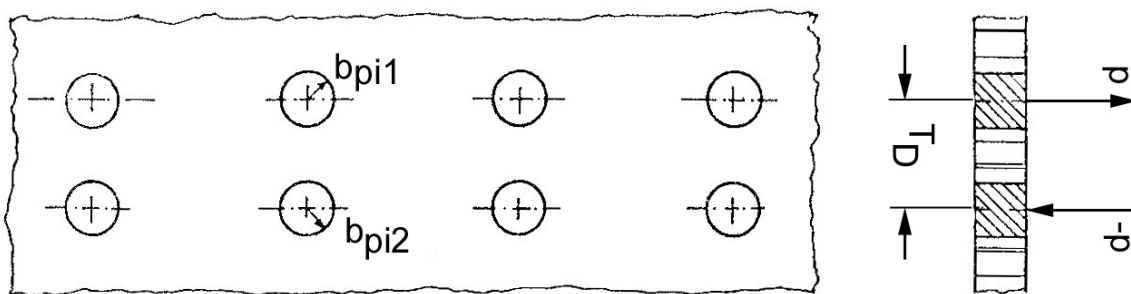

Figure 19-3 Insert groups: series of inserts loaded in opposite directions

The reduced load capability of each insert can be estimated for the:

- First and last insert, and
- Intermediate inserts.

19.4.2 First and last insert

Using Eqn. [19.1-1] and Eqn. [19.2-1] gives:

$$P_{SS1}^* = P_{SS1} \eta_{IS1} \eta_{IC} \quad [19.4-1]$$

19.4.3 Intermediate inserts

Using Eqn. 16.03.1 and Eqn. 16.02.1 gives:

$$P_{SSi}^* = P_{SSi} (\eta_{ISi} + \eta_{ISr} - 1) \eta_{IC} \quad [19.4-2]$$

where:

$$\eta_{IC} = \begin{cases} 0.9 & \text{for } a \leq 5(b_{pi1} + b_{pi2}) \\ 1.0 & \text{for } a > 5(b_{pi1} + b_{pi2}) \end{cases} \quad [19.4-3]$$

a distance between insert series.

b_{pi1} potting radius for insert No. i of first series.

b_{pi2} potting radius for insert No. i of second series.

[See also: Figure 19-3]

19.5 Insert groups: Loaded in same direction

19.5.1 General

Higher loads can be applied to a number of inserts using brackets, e.g. a group of 3, 4, 5 or 6 inserts, as shown in Figure 19-4.

19.5.2 Equal and equidistant inserts

For equal and equidistant inserts, the load-capability of each insert of the group is:

$$P_{SS}^* = \eta_G P_{SS} \quad [19.5-1]$$

where:

P_{SS}^* reduced capability of insert.

P_{SS} initial capability of single insert.

η_G interference coefficient for a group of equidistant inserts, depending on the number of inserts:

$$\eta_G = 2 \left(\frac{n-1}{n} \eta_{IS} + \frac{1}{n} - 0.5 \right) \quad [19.5-2]$$

where:

n number of inserts in the group;

η_{IS} interference coefficient for 2 inserts loaded in the same direction, [See: 19.1; Eqn. [19.1-1]] with $b_{pi} = b_{p1} = b_p$: i.e. $b_{p1} / b_{p2} = 1$, gives:

$$\eta_{IS} = 1/2 (1 + a/10b_p) \quad [19.5-3]$$

19.5.2.1 Boundary values

Eqn. [19.5-2] satisfies the boundary values:

$$\eta_G = 1 \quad \text{for } a/b_p = 10 \text{ or } \eta_{IS} = 1$$

(no further mutual interference)

$$\eta_G = 1/n \quad \text{for } a/b_p = 0 \text{ or } \eta_{IS} = 0.5$$

(n inserts concentrated in 1 insert)

19.5.2.2 Validity

Eqn. [19.5-2] and Eqn. [19.5-3] are only valid for $a \leq 10b_p$.

For a greater insert distance:

$$\eta_G = \eta_{IS} = 1 \quad \text{for } a > 10b_p \quad [19.5-4]$$

Figure 19-4 shows a plot of Eqn. [19.5-2] and Eqn. [19.5-3].

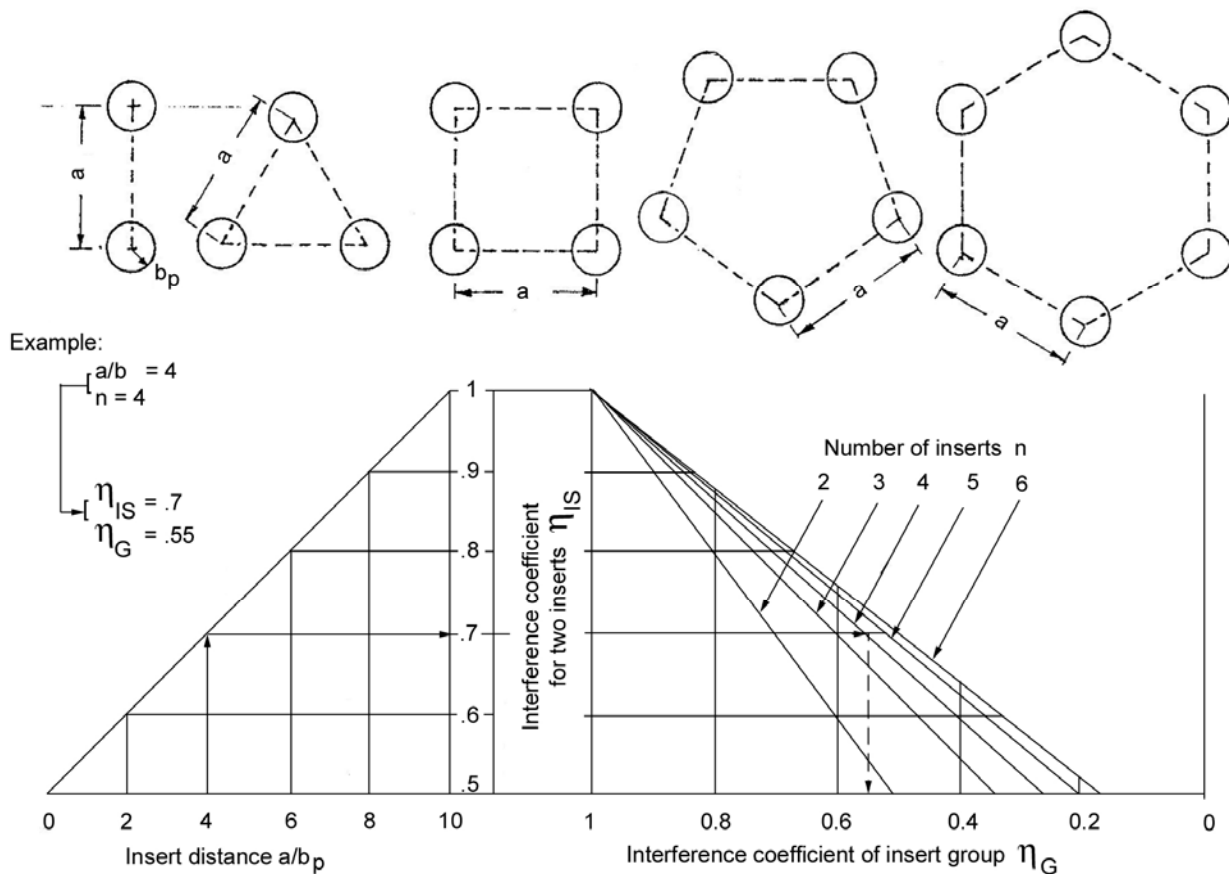

Figure 19-4: Insert groups: Interference coefficient for a group of equal and equidistant inserts

19.6 Composite face sheets

19.6.1 Out-of-plane loading

Two inserts can be placed close to each other so that their effective potting radii are nearly together. If both inserts are loaded by out-of-plane loads, shear forces cannot be created in the adjacent cell walls. In this case, these two inserts act as one insert, [19-1].

The group effect of out-of-plane loaded inserts is primarily related to the core used.

Therefore, the group effect can be considered relevant for sandwich panels with CFRP face sheets.

19.6.2 In-plane loaded inserts

Based on the investigation of stress concentrations in metallic structures it is known that severe interactions between two or more holes exist. This is especially true when the holes are considered as 'pin loaded' and located close to a sandwich panels edge or if several adjacent holes are loaded in different load directions, [19-1].

The global stress of the panel, the stress concentration effect of the insert hole and the local stresses induced by the insert (pin) load act in combination. In the case of several adjacent inserts, the situation is more complex.

CFRP face sheets have brittle failure behaviour, sometimes with a damage tolerance of an equivalent hole of between 3 mm and 5 mm.

This is not always critical with respect to the in-plane load capability of an insert, but implementation of an insert can result in a total failure of the panel itself.

A CFRP sandwich panel cannot be adequately designed without reflecting such effects. They are highly relevant with respect to the correct superposition of local stress failure criteria, which are valid for CFRP.

Owing to the complicated nature of the CFRP composites, it can be concluded that tests are necessary to obtain reliable data for group effects.

19.7 References

19.7.1 General

- [19-1] Lassi Syvänen, Kari Marjoniemi, Ari Ripatti, Markku Pykäläinen: Patria Finaviacomp Oy, Finland
 'Analysis models for insert design rules in sandwich panels with CFRP facings'
 Patria report: GS1-PFC-RP-0002 (January 2003)
 ESTEC Contract No. 14076/99
- [19-2] W. Hertel, W. Paul and D. Wagner - ERNO Raumfahrttechnik GmbH, Structures Dept., Bremen, D.
 'Standardisation Programme for Design and Testing of Inserts', ESA CR (P) 1498, ESA Contract No. 3442/77/NL/PP, 1981.

-
- [19-3] W. Paul and D. Wagner ERNO Raumfahrttechnik GmbH,
Structures Dept., Bremen, D.
'Standardisation Programme for Design and Testing of Inserts, Rider II',
ESA CR (P) 1665, ESA Contract No. 3442/77/NL/PP, 1981.
- [19-4] 'Reevaluation of Potting Procedure - Final Report', July 1990. MBB-ERNO
(Bremen). ESTEC Contract No. 7830/88/NL/PH(SC)
- [19-5] 'Standardisation of design analysis and testing of inserts in structural
sandwich elements- Final Report'. MBB-ERNO (3442/77/NL/PP)
- [19-6] 'Standardisation of design analysis and testing of inserts in structural
sandwich elements- Final Report'. MBB-ERNO (3442/77/NL/PP- Rider 1)

20 Stiffness

20.1 Introduction

20.1.1 Overview

The insert stiffness can be an important factor for the evaluation of loads at fixing points. Two particular cases are highlighted, [20-1]:

- Rotational stiffness
- In-plane stiffness

20.1.2 Rotational stiffness

If the rotational stiffness, K_{θ} is too high, then unrealistic bending moments can be calculated by finite element models. This results in local oversizing of the structure and fixing elements, e.g. bolts or washers, [See: 20.2].

20.1.3 In-plane stiffness

If the in-plane stiffness, $K_{in-plane}$ is too high, unrealistic in-plane loads can be calculated and also result in oversizing, [See: 20.2].

NOTE Example: In-plane stiffness has a significant effect on the in-plane interface forces between an aluminium alloy equipment box and a sandwich panel with CFRP face sheets in a thermal environment.

20.1.4 Out-of-plane stiffness

Similarly if the out-of-plane stiffness, $K_{out-of-plane}$ is too high, calculation and oversizing effects are possible, [See: 20.2].

NOTE Example: Axial stiffness is an important parameter in some design cases, e.g. struts or point fixings of solar arrays to sandwich panels. Usually the fixing bracket has a specified stiffness that can influence the insert-sandwich system stiffness.

[See also: 20.2 for analysis and test of an example from SILEX]

20.2 Analysis and test

20.2.1 General

The different values of insert stiffness determined by analysis and testing are described, using an example from the SILEX project, [20-1].

General comments regarding the determination insert stiffness for sandwich panels having composite face sheets are also given.

20.2.2 Analysis

Hand calculations or FE, indicate stiffness values of, [20-1]:

- Rotational stiffness: $K_{\theta} = 1 \times 10^4$ mN/rad;
- In-plane stiffness: $K_{in-plane} = 1 \times 10^8$ N/m.

20.2.3 Testing

20.2.3.1 Configuration

In the SILEX project, tests on insert configurations determined the stiffness values. Table 20-1 lists the sandwich construction and inserts, [20-1].

Table 20-1: Insert stiffness: SILEX test configuration

Face sheets	CFRP M55J / 914; Quasi-isotropic lay-up. Thickness = 0.8 mm
Core	5056 3-20; height = 16.5 mm
Inserts	Standard: 14 mm dia.; h = 15 mm
	Special through: 14 mm dia.; h = 18.1 mm

20.2.3.2 Stiffness values

The values determined by testing were:

- Rotational: $2 \times 10^3 < K_{\theta} < 4 \times 10^3$ mN/rad
- In-plane: $1 \times 10^7 < K_{in-plane} < 5 \times 10^7$ N/m
- Out-of-plane: $5 \times 10^6 < K_{out-of-plane} < 1.2 \times 10^7$ N/m

20.2.4 Comparison of analysis and test values

Table 20-2 compares stiffness values obtained by analysis with those obtained by testing, [20-1].

The results are not very accurate because many assumptions were made to obtain a stiffness of the insert alone, i.e. excluding the other parts of the assembly; test-jig. However, they give a good order-of-magnitude result and indicate that the values obtained by 'analysis' are high.

Table 20-2: Insert stiffness: Comparison of analysis and test

Insert stiffness	Analysis	Test
Rotational (mN/rad)	1×10^4	$2 \times 10^3 < K_{\theta} < 4 \times 10^3$
In-plane (N/m)	1×10^8	$1 \times 10^7 < K_{in-plane} < 5 \times 10^7$
Out-of-plane (N/m)	-	$5 \times 10^6 < K_{out-of-plane} < 1.2 \times 10^7$

20.2.5 Composite face sheets

20.2.5.1 Out-of-plane stiffness

Out-of-plane stiffness is determined by out-of-plane tests using proper instrumentation to measure displacement and force.

Although an estimation of the out-of-plane stiffness can be made by FE analysis, reliable results are obtained only by test.

20.3 References

20.3.1 General

- [20-1] 'MMS Contribution to ESA Insert Design Handbook'
 Matra Marconi Space Report No. NT/102/BG/355013.96 (December 1996).

21 Fatigue

21.1 Insert fatigue life

21.1.1 General

The load-carrying capability of all the component parts of a potted insert system, i.e. core, potting, face sheet, insert and bolt, can be degraded by repeated loading as the service life increases.

The failure of the insert element itself is not experienced provided that there is an adequate fillet radius of the lower flange connection, which is defined in most standards.

Failures of the face sheets have never been experienced in spacecraft insert panel design.

NOTE The dimensions of the bracket foot can be relevant, [See: 21.4].

Bolts in inserts are not covered here, and are specified in accordance with appropriate standards, [See: ECSS-Q-ST-70-46].

The remaining components relevant to degradation under operational loads are the:

- Potting,
- Honeycomb core.

21.1.2 Potting

A correctly potted body is not subject to fatigue degradation if the surface treatment of the inner flange provides a good adhesive bond with the resin, [21-1]. [See also: 5.5]. The strength of the potting body under operational condition is influenced by elevated temperatures, [See also: 22.1].

21.1.3 Honeycomb core

The honeycomb core is significantly stressed by loads normal to the plane of the face sheet.

Cycling bending or torsion of inserts needs to be excluded in design, e.g. by using a sufficiently long bracket foot; insert groups.

The accumulated fatigue damage in the core under repeated loads normal to plane is dependent upon three major variables:

- Local shear stresses: potting dimensions, height of core, stress concentrations, [See: 21.2]
- Applied load sequence: mean stress, alternating stress, number of cycles, [See: 21.3; 21.4]
- Material fatigue resistance, [See: 21.5]

21.2 Core local stress: Normal loads to plane

21.2.1 General

The core shear stress around a potted insert is determined using the mathematical model in Annex C. The ultimate tensile capabilities P_{SS} are based on the core $\tau_{c \text{ crit min}}$ values.

NOTE For guidance, Annex B contains examples of plots for individual insert configurations. These implicitly contain the load-core stress τ_c data.

21.2.2 Core circular stress

According to the model in Annex C, the circular shear stress in the core becomes, [See also: Figure 16-1]:

$$\tau_c = \frac{C^* K r_{\max}}{2\pi b_p c} F \quad [21.2-1]$$

with:

$$\tau_c = \tau_{c \text{ crit min}} \quad \text{and} \quad F = P_{SS},$$

The first term is known:

$$\frac{\tau_{c \text{ crit min}}}{P_{SS \text{ min}}} = \frac{C^* K r_{\max}}{2\pi b_p c} \quad [21.2-2]$$

Therefore the circular stress τ_c under a load P is:

$$\tau_c = F \frac{\tau_{c \text{ crit min}}}{P_{SS \text{ min}}} \quad [21.2-3]$$

[See also: Table 6-3 and Table 6-4 for core properties]

P_{SS} values are shown in Figure 21-1, [See also: Annex B].

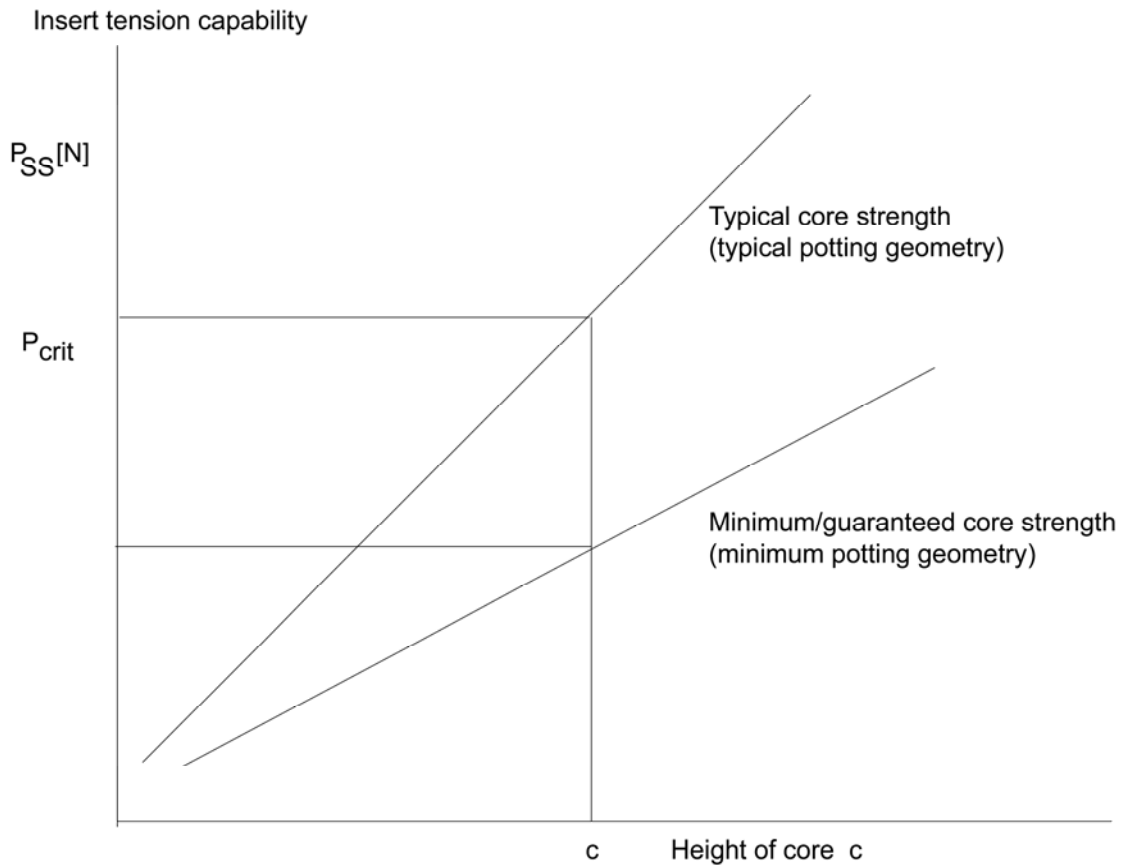

[See: Table 6-3 and Table 6-4]

Figure 21-1: Static strength values with core height

21.2.3 Example

Given the sandwich-insert configuration:

- Aluminium core: 3/16-5052-.0007P;
- Core height, $c = 30$ mm;
- Aluminium face sheets: 0.4 mm thick;
- Insert diameter = 14 mm.

21.2.3.1 Core stress

From capability plots, [See: Annex B; Table 6-3 and Table 6-4].

$$\begin{aligned} \tau_{cmin} &= \frac{0.57}{1290} p \\ &= 4.4 \times 10^{-4} \left[\frac{1}{\text{mm}^2} \right] p \end{aligned} \quad [21.2-4]$$

This core stress, τ_c is seen as the maximum (axially symmetrical) gross value occurring in the vicinity of the fully potted body in an infinite sandwich plate. Consequently it does not contain:

- Shear stress variation versus height induced by partial potting;

- Influences from the edges close to the insert;
- Influences from other inserts adjacent to the considered insert;

$$\tau_{c \text{ local}} = \tau_c K_t \quad [21.2-5]$$

with:

$$K_t = \varepsilon \prod_{j=1}^s K_{tj} \quad [21.2-6]$$

where:

s = number of effects applicable (to be superimposed).

21.2.3.2 Stress concentration factors

Table 21-1 summarises different reasons for locally increased stresses (with links to relevant information) and means of determining K_t with respect to ultimate strength, [See: 12.1]

NOTE 1 Cyclic torsion or bending of inserts is avoided by using appropriate insert groups.

NOTE 2 If significant cyclic torsion or bending cannot be avoided, verification is based on detailed tests.

Table 21-1: Fatigue: Stress concentration factors for local stress

Effect	Stress concentration factor (K_i)	Comment / Link
Partial potting	$K_{tpp} = \left(\frac{c}{h_p} \right)^n$	$n = 0.8$ for aluminium core
Influence of free border ⁽¹⁾	$K_{tFB} = \frac{1}{\eta_{FB}^2}$	η_{FB} [See: 18.1]
Inserts close to each other ⁽¹⁾	$K_{tAJ} = \frac{1}{\eta_{AJ}^2}$	η_{AJ} [See:19.1]
Elevated temperature ⁽¹⁾	$K_{TN} = \frac{1}{\eta_{TH}}$	[See: 22.1]
Long-term influences ⁽¹⁾	$K_{tLT} = \frac{1}{\eta_{LT}}$	[See: 22.1]
Combination of: <ul style="list-style-type: none"> • Normal loads, F and • Shear loads, Q. 	$K_{tQ} = 1$	Provided that the load Q acts in-plane of face sheet, [See: 17.1].
NOTE (1) These values are for preliminary design and need to be supported by testing.		
$\tau_{local} = \tau \cdot \prod_{i=1}^s K_{ti}$		
NOTE (2) Local stress:		

In this example case, assuming that the insert load is related linearly to acceleration, each set $i, i+1$ of cyclic load with constant amplitude is represented by:

- Mean load: $P_{mean\ i,i+1}$
- Load amplitude: $P_{Ai,i+1}$
- Number of cycles: $N_{i,j+1} = \bar{N}_{i+1} - \bar{N}_i$

Figure 21-2 shows a schematic of a design load spectrum, [See also: 21.4].

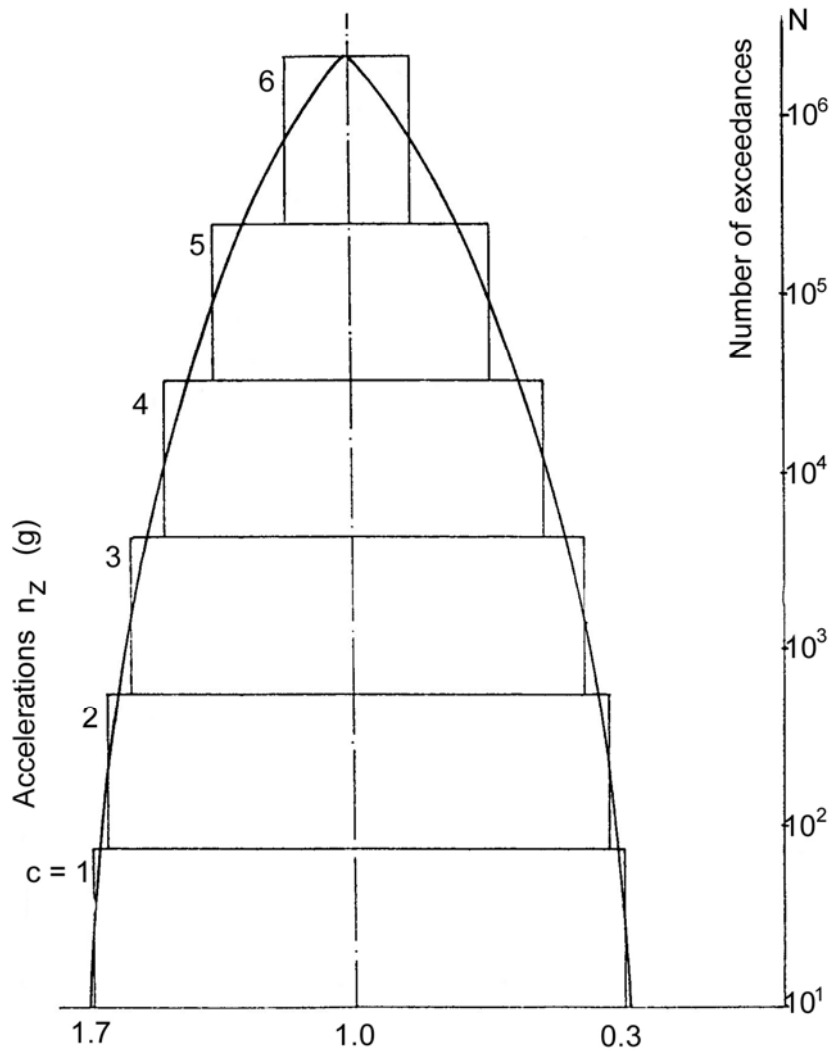

Figure 21-2: Schematic: Design load spectrum

21.3 Load-stress sequence: Constant amplitude

21.3.1 General

The load or local stress sequence can be sinusoidal with an amplitude of local stress τ_a , and a mean value of τ_{mean} :

$$\tau = \tau_{mean} + \tau_a \sin(\omega t) \quad [21.3-1]$$

21.3.2 Mean stress ratio

The maximum core stress $\hat{\tau} = |\tau_{mean}| + \tau_a$ can be expressed by a mean stress ratio.

As the shear-loaded core webs under tensile load react in much the same way as under compressive load, the relevant R ratio becomes:

$$R = \frac{|\tau_{mean}| - \tau_A}{|\tau_{mean}| + \tau_A} \quad [21.3-2]$$

21.3.3 Maximum peak load

Sometimes it is preferable to use the maximum peak load \hat{F} or $\hat{\tau}$:

$$\hat{F} = \frac{2P_a}{1-R} \quad [21.3-3]$$

$$\hat{\tau} = \frac{2\tau_a}{1-R} \quad [21.3-4]$$

21.4 Load-stress sequence: Spectra of constant amplitude

21.4.1 General

Within a design, different sets of load amplitude (R ratios) and number of occurrences can be needed. These spectra are also presented as a distribution.

21.4.2 Example

Figure 21-2 shows the number of times a certain acceleration level is exceeded with constant mean acceleration, which can also be approximated by certain steps, i . \bar{N} is the accumulated number of times a certain load level is exceeded.

As the amplitude ($F_{A i, i+1}$) is different for each step, the mean stress ratio R is also different for each individual step.

Special attention is necessary if the total sequence of load history is formed by different spectra with significantly different mean loads. Sometimes these variations form the major part of the load history with respect to fatigue damage, e.g. the ground-to-air-to-ground cycle. Such variations of mean loads should be considered as additional cycles.

21.5 Fatigue life: Constant load amplitude

21.5.1 Fatigue damage

Fatigue damage is an irreversible response of the insert system (especially the core) to repeated cyclic loading.

After a certain damage accumulation, the item fails under the applied peak load.

[See also: 21.6 for fatigue damage accumulation]

21.5.2 Fatigue life

The results of a cyclic loading test to failure are shown in the classical S/N plots which, in the case of insert application, can be approximated by:

$$\tau_a = C N^{-1/k} \quad \text{for } \tau_{mean} + \tau_A < \tau_{crit} \quad [21.5-1]$$

The coefficient C depends on the mean stress τ_{mean} , which can be considered as equal to the alternating stress τ_A .

As the mean stress ratio R , [See: 21.3; Eqn. [21.3-2]] is usually not constant, then Eqn. [21.5-2] is more suitable for the analysis:

$$\tau_a = \left(\frac{2}{1-R} \right)^m C_A N^{-1/k} \quad \text{for } \frac{\hat{\tau}}{K_t} < \tau_{crit} \quad [21.5-2]$$

Often, stresses are available for the maximum peak load F resulting in a maximum local peak stress $\hat{\tau}$.

With:

$$\hat{\tau} = \left(\frac{2}{1-R} \right) \tau_a \quad [21.5-3]$$

Eqn. [21.5-2] becomes:

$$\hat{\tau} = \left(\frac{2}{1-R} \right)^{m+1} C_A N^{-1/k} \quad [21.5-4]$$

Together with:

$$F = \frac{2\pi b_p^c}{C^* K_{rmax}} \tau_c \quad [21.5-5]$$

And:

$$\hat{\tau}_c = \frac{\hat{\tau}}{K_t} \quad [21.5-6]$$

[See: 21.2]

$$\hat{F} = \frac{2\pi b_p^c}{C^* K_{rmax} K_t} \left(\frac{2}{1-R} \right)^{m+1} C_A N^{-1/k} \quad [21.5-7]$$

or with:

$$\tau_c = \frac{P_{SS}}{\tau_{crit}} \quad [21.5-8]$$

[See: 21.2]

$$\hat{F} = \left(\frac{P_{SS}}{\tau_{critmin}} \right) \frac{1}{K_t} \left(\frac{2}{1-R} \right)^{m+1} C_A N^{-1/k} \quad [21.5-9]$$

Coefficients for Eqn. 18.05.9 for different honeycomb types are given in Table 21-2

In accordance with static strength capabilities:

- minimum values are based on:
 - Minimum static core strength,
 - Minimum but proper potting size, and
 - Lower boundary variation of the mathematical model.
- typical values are based on:
 - Average typical strength of core,
 - Typical potting geometry, and
 - Typical values of the mathematical model.

NOTE It is advisable to use 'minimum data' only to ensure safety and reliability where the failure of one single insert should be avoided.

21.5.3 Re-evaluation of core strength variation

The variation of the core static strength, τ_W can also influence the fatigue life behaviour of an actual batch of core material. This was found to be true for low-cycle fatigue areas only.

For a life of 200 000 cycles, the tolerable stress $\hat{\tau}$ was not affected at all.

Where $N = 1$, the tolerable stress becomes $\alpha \times \hat{\tau}_{\min(N=1)}$, if τ_W is actually $\tau_W \alpha$.

Based on these findings, the linear reduction of C_A by the ratio $\tau_{Wmin}/\tau_{Wactual}$ and $\tau_{Wtyp}/\tau_{Wactual}$ used previously was found rather crude and too conservative for $N < 200\ 000$.

A re-evaluation of the values C_A and $1/\kappa$, [21-1] is shown in brackets in Table 21-2.

Table 21-2: Fatigue: Coefficients to determine peak load

Core type (metallic)	$C_A^{(1)(3)}$	$1/\kappa^{(1)(3)}$
3/16 - 5052 - .0007 p	1.1968	0.1129
3/16 - 5052 - .0010 p	(1.86)	(0.113)
3/16 - 5056 - .0007 p	1.4040	0.126
3/16 - 5056 - .0010 p	(2.19)	(0.126)
1/8 - 5052 - .0007 p	(1.86)	(0.113)
1/8 - 5052 - .0010 p	(2.83)	(0.113)
1/8 - 5052 - .0015 p	4.30	0.103
1/8 - 5056 - .0007 p	(2.19)	(0.126)
1/8 - 5056 - .0010 p	(3.32)	(0.126)
NOTE (1) Values in brackets taken from test results from a re-evaluation of core density.		
NOTE (2) $\hat{F} = \frac{P_{SS}}{\tau_c} \left(\frac{h_p}{c}\right)^{0.8} \left(\frac{2}{1-R}\right)^{m+1} C_A N^{-1/\kappa} \quad [21.5-10]$ <p style="margin-left: 40px;">where:</p> <p style="margin-left: 80px;">$m+1 = 0.3556$; $P_{SS} =$ static strength; $c =$ core height; $\tau_c =$ min. circular core shear strength; $h_p =$ potting height</p>		
NOTE (3) Using minimum core properties and typical potting diameter ($h_{p \text{ typ}}$). A scatter factor of 4 should be used.		

21.5.4 Insert fatigue life: Metallic cores

21.5.4.1 Core type: 3/16-5052-.0007p

The fatigue life behaviour of inserts used in the most frequently-aluminium core types, are presented graphically.

These graphs were derived for:

- Core height: 20 mm;
- 2024 aluminium face sheet thickness: 0.1mm.

Corrective coefficients are tabulated for:

- Face sheet thickness;
- Core height (F_{cf});
- Partial potting (F_{pp});
- Product of correction factors ($F_{cf} \times F_{pp}$).

21.5.4.2 Links to fatigue life data

Table 21-3: Links to fatigue life data

Insert diameter. (mm)	Correction factors	Fatigue graph
9	Table 21-4	Figure 21-3
11	Table 21-5	Figure 21-4
14	Table 21-6	Figure 21-5
17.5	Table 21-7	Figure 21-6
22	Table 21-8	Figure 21-7
NOTE	All graphs based on: Core type: 3/16-5052-.0007p; Core height 20 mm; Face sheet: 2024 aluminium, 0.1 mm thick; Insert height 9 mm.	

Table 21-4: Insert diameter 9 mm: Fatigue correction factors

Multiply the given correction factors (F_{cf}) and (F_{pp}) with the load values from Figure 21-3.

Core height (mm)	Face sheet thickness (mm)	Correction factor, F_{cf}	Partial potting factor, F_{pp}	($F_{cf} \times F_{pp}$)
10	0.1	0.8980	0.6473	0.5812
20	0.1	1.0000	1.0000	1.0000
30	0.1	1.0692	1.1052	1.1817
40	0.1	1.1228	1.1506	1.2918
50	0.1	1.1670	1.1655	1.3601
10	0.2	1.0359	0.6473	0.6705
20	0.2	1.1153	1.0000	1.1153
30	0.2	1.1738	1.1052	1.2973
40	0.2	1.2206	1.1506	1.4044
50	0.2	1.2600	1.1655	1.4685
10	0.3	1.1994	0.6473	0.7763
20	0.3	1.2497	1.0000	1.2497
30	0.3	1.1944	1.1052	1.4306
40	0.3	1.3326	1.1506	1.5333
50	0.3	1.3660	1.1655	1.5921
10	0.4	1.3870	0.6473	0.8977
20	0.4	1.4020	1.0000	1.4020
30	0.4	1.4302	1.1052	1.5807
40	0.4	1.4581	1.1506	1.6777
50	0.4	1.4842	1.1655	1.7299
10	0.5	1.5986	0.6473	1.0347
20	0.5	1.5715	1.0000	1.5715
30	0.5	1.5804	1.1052	1.7467
40	0.5	1.5964	1.1506	1.8368
50	0.5	1.6141	1.1655	1.8813
10	0.6	1.8357	0.6473	1.1881
20	0.6	1.7584	1.0000	1.7584
30	0.6	1.7448	1.1052	1.9285
40	0.6	1.7472	1.1506	2.0103
50	0.6	1.7553	1.1655	2.0458
10	0.7	2.1007	0.6473	1.3597
20	0.7	1.9635	1.0000	1.9635
30	0.7	1.9238	1.1052	2.1262
40	0.7	1.9104	1.1506	2.1981
50	0.7	1.9077	1.1655	2.2234
10	0.8	2.3972	0.6473	1.5516
20	0.8	2.1882	1.0000	2.1882
30	0.8	2.1180	1.1052	2.3408
40	0.8	2.0866	1.1506	2.4008
50	0.8	2.0715	1.1655	2.4144

NOTE Core type - 3/16-5052-.0007p; Core height = 20 mm;
 Face sheet: 2024 aluminium, 0.1mm thick;
 Insert height, $h_i = 9$ mm.

Cyclic loading 3/16-5052-.0007 Core Insert Diameter = 9 mm
 Insert height $h_i = 9$ mm; Face sheet material Al 2024; Parameter R

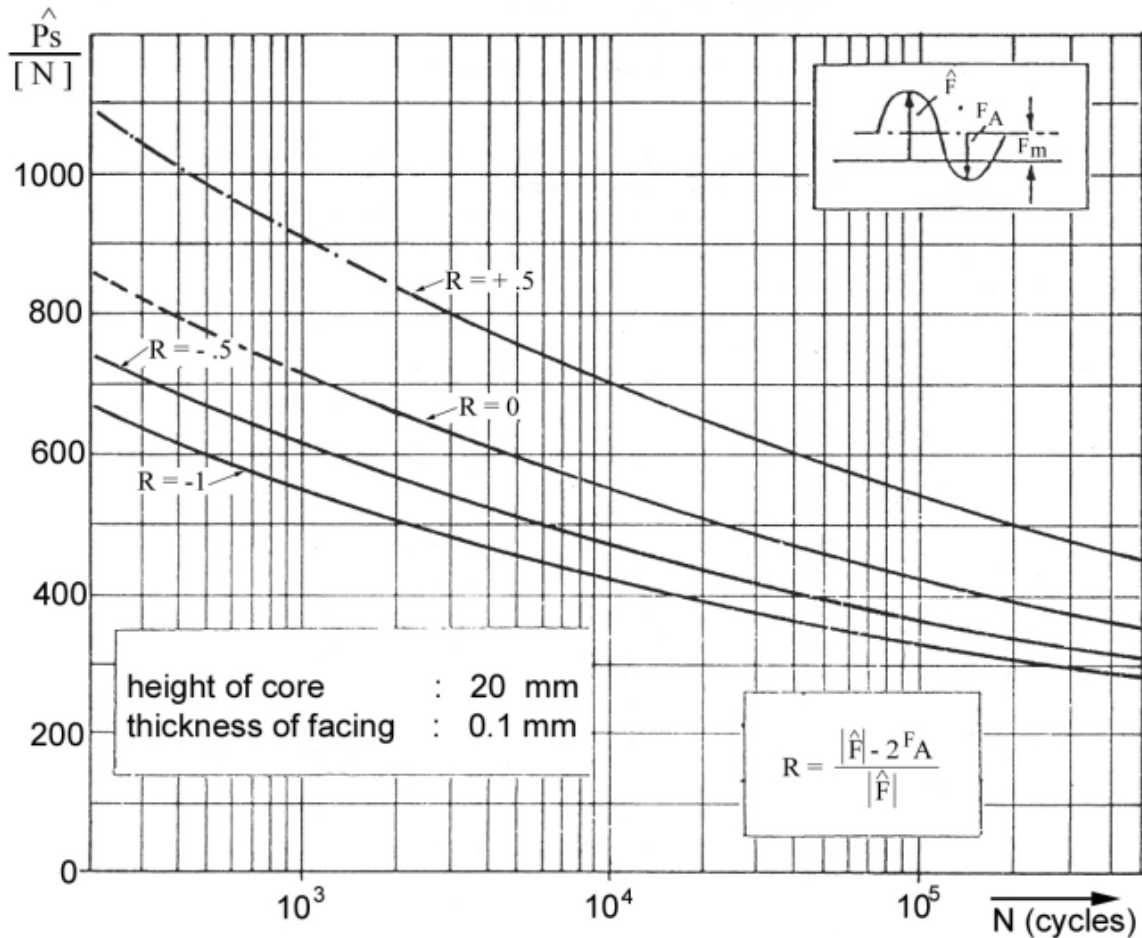

For standard geometries ($f = 0.1$ mm, $c = 20$ mm) as above:

$$\hat{P}_S = 1208.2 \times \left(\frac{2}{1-R} \right)^{0.3556} \times N^{-0.1129} \quad \hat{P}_S < P_{SS}$$

For other geometries:

$$\hat{P} = \hat{P}_S \times F_{C-F} \times F_{PP}$$

[See Table 21-4]

Figure 21-3: Insert fatigue life: Insert diameter 9 mm



Table 21-5: Insert diameter 11 mm: Fatigue correction factors

Multiply the given correction factors (F_{cf}) and (F_{pp}) with the load values from Figure 21-4.

Core height (mm)	Face sheet thickness (mm)	Correction factor, F_{cf}	Partial potting factor, F_{pp}	($F_{cf} \times F_{pp}$)
10	0.1	0.8961	0.6473	0.5800
20	0.1	1.0000	1.0000	1.0000
30	0.1	1.0703	1.1052	1.1829
40	0.1	1.1247	1.1506	1.2940
50	0.1	1.1695	1.1655	1.3631
10	0.2	1.0227	0.6473	0.6620
20	0.2	1.1059	1.0000	1.1059
30	0.2	1.1664	1.1052	1.2892
40	0.2	1.2146	1.1506	1.3975
50	0.2	1.2550	1.1655	1.4627
10	0.3	1.1718	0.6473	0.7584
20	0.3	1.2286	1.0000	1.2286
30	0.3	1.2766	1.1052	1.4110
40	0.3	1.3170	1.1506	1.5154
50	0.3	1.3520	1.1655	1.5757
10	0.4	1.3418	0.6473	0.8685
20	0.4	1.3669	1.0000	1.3669
30	0.4	1.4001	1.1052	1.5474
40	0.4	1.4313	1.1506	1.6468
50	0.4	1.4596	1.1655	1.7012
10	0.5	1.5325	0.6473	0.9919
20	0.5	1.5203	1.0000	1.5203
30	0.5	1.5362	1.1052	1.6979
40	0.5	1.5567	1.1506	1.7911
50	0.5	1.5775	1.1655	1.8386
10	0.6	1.7446	0.6473	1.1292
20	0.6	1.6885	1.0000	1.6885
30	0.6	1.6846	1.1052	1.8619
40	0.6	1.6929	1.1506	1.9479
50	0.6	1.7053	1.1655	1.9875
10	0.7	1.9798	0.6473	1.2815
20	0.7	1.8721	1.0000	1.8721
30	0.7	1.8454	1.1052	2.0396
40	0.7	1.8399	1.1506	2.1170
50	0.7	1.8427	1.1655	2.1477
10	0.8	2.2405	0.6473	1.4502
20	0.8	2.0719	1.0000	2.0719
30	0.8	2.0190	1.1052	2.2314
40	0.8	1.9979	1.1506	2.2987
50	0.8	1.9899	1.1655	2.3193

NOTE Core type - 3/16-5052-.0007p; Core height = 20 mm;
 Face sheet: 2024 aluminium, 0.1mm thick;
 Insert height, $h_i = 9$ mm.

Cyclic loading 3/16-5052-.0007 Core Insert Diameter = 11 mm
 Insert height $h_i = 9$ mm; Face sheet material Al 2024; Parameter R

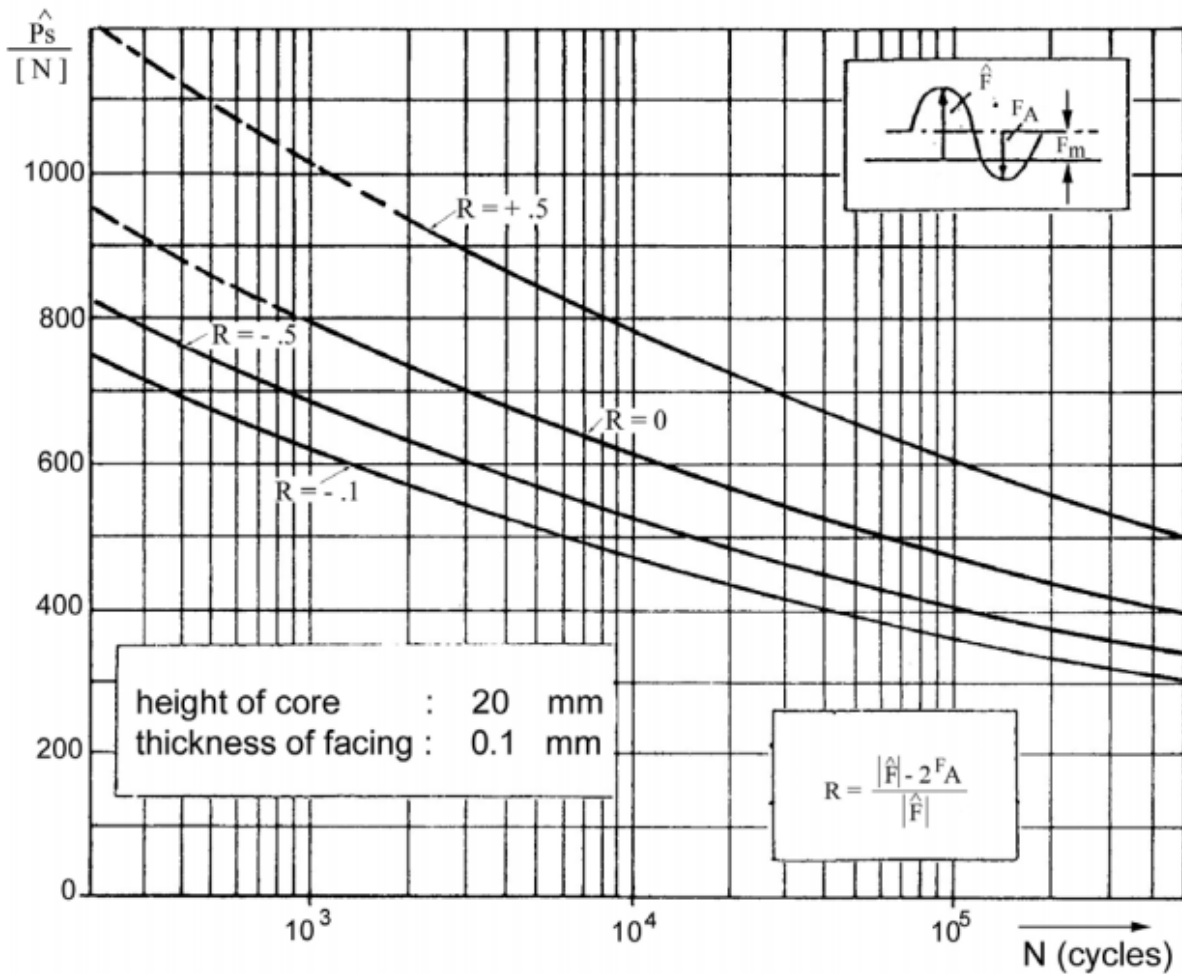

For standard geometries ($f = 0.1$ mm, $c = 20$ mm) as above:

$$\hat{P}_S = 1344.6 \times \left(\frac{2}{1-R} \right)^{0.3556} \times N^{-0.1129} \quad \hat{P}_S < P_{SS}$$

For other geometries:

$$\hat{P} = \hat{P}_S \times F_{C-F} \times F_{PP}$$

[See Table 21-5]

Figure 21-4: Insert fatigue life: Insert diameter 11 mm



Table 21-6: Insert diameter 14 mm: Fatigue correction factors

Multiply the given correction factors (F_{cf}) and (F_{pp}) with the load values from Figure 21-5.

Core height (mm)	Face sheet thickness (mm)	Correction factor, F_{cf}	Partial potting factor, F_{pp}	($F_{cf} \times F_{pp}$)
10	0.1	0.8938	0.6473	0.5785
20	0.1	1.0000	1.0000	1.0000
30	0.1	1.0716	1.1052	1.1844
40	0.1	1.1270	1.1506	1.2967
50	0.1	1.1726	1.1655	1.3667
10	0.2	1.0072	0.6473	0.6519
20	0.2	1.0949	1.0000	1.0949
30	0.2	1.1577	1.1052	1.2796
40	0.2	1.2075	1.1506	1.3893
50	0.2	1.2491	1.1655	1.4558
10	0.3	1.1393	0.6473	0.7374
20	0.3	1.2038	1.0000	1.2038
30	0.3	1.2557	1.1052	1.3878
40	0.3	1.2986	1.1506	1.4942
50	0.3	1.3354	1.1655	1.5565
10	0.4	1.2891	0.6473	0.8344
20	0.4	1.3258	1.0000	1.3258
30	0.4	1.3648	1.1052	1.5084
40	0.4	1.3996	1.1506	1.6104
50	0.4	1.4307	1.1655	1.6675
10	0.5	1.4559	0.6473	0.9424
20	0.5	1.4604	1.0000	1.4604
30	0.5	1.4844	1.1052	1.6407
40	0.5	1.5101	1.1506	1.7375
50	0.5	1.5346	1.1655	1.7886
10	0.6	1.6400	0.6473	1.0615
20	0.6	1.6073	1.0000	1.6073
30	0.6	1.6144	1.1052	1.7843
40	0.6	1.6295	1.1506	1.8749
50	0.6	1.6468	1.1655	1.9193
10	0.7	1.8423	0.6473	1.1924
20	0.7	1.7666	1.0000	1.7666
30	0.7	1.7544	1.1052	1.9391
40	0.7	1.7579	1.1506	2.0226
50	0.7	1.7670	1.1655	2.0594
10	0.8	2.0641	0.6473	1.3360
20	0.8	1.9388	1.0000	1.9388
30	0.8	1.9048	1.1052	2.1053
40	0.8	1.8952	1.1506	2.1806
50	0.8	1.8952	1.1655	2.2088

NOTE Core type - 3/16-5052-.0007p; Core height = 20 mm;
 Face sheet: 2024 aluminium, 0.1mm thick;
 Insert height, $h_i = 9$ mm.

Cyclic loading 3/16-5052-.0007 Core Insert Diameter = 14 mm

Insert height $h_i = 9$ mm; Face sheet material Al 2024; Parameter R

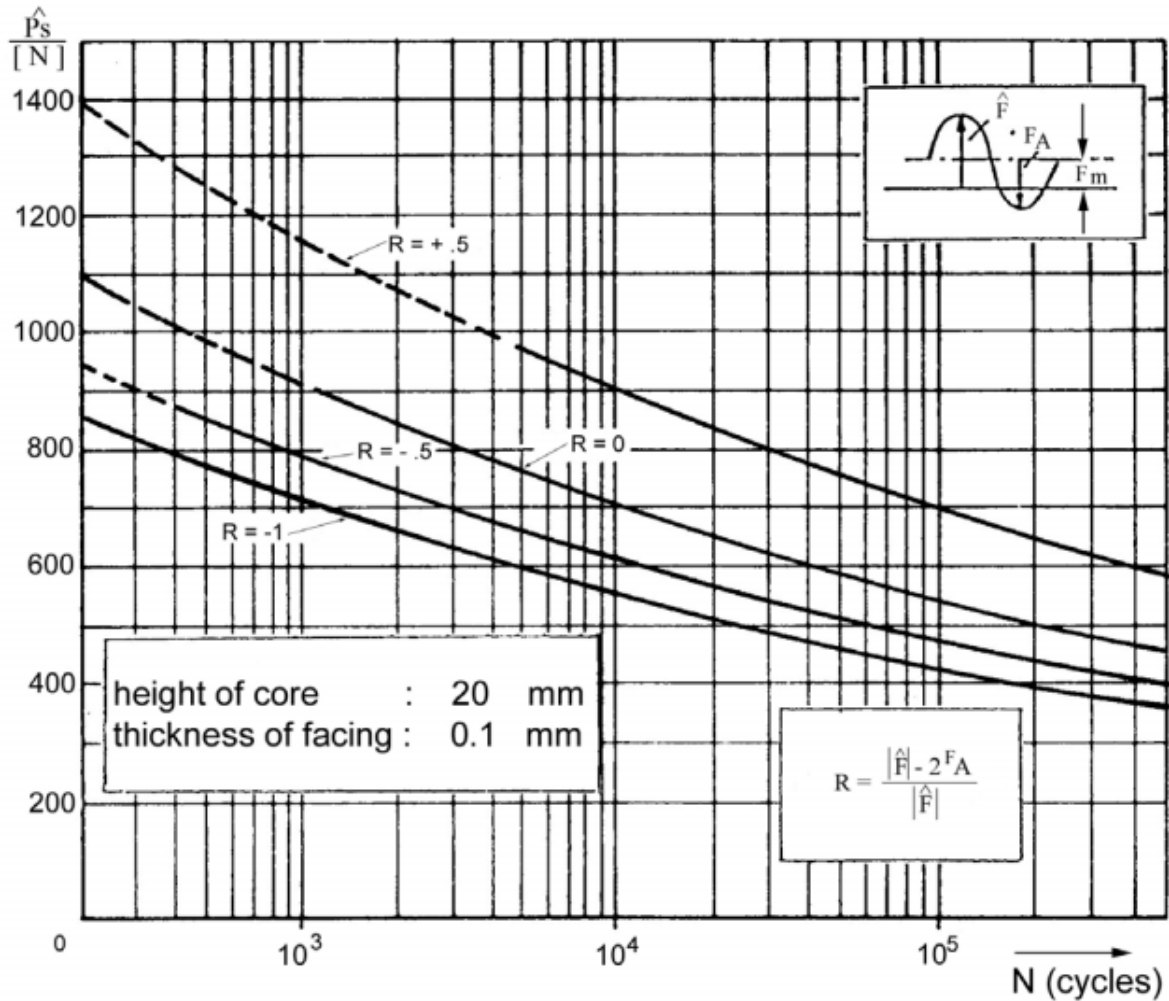

For standard geometries ($f = 0.1$ mm, $c = 20$ mm) as above:

$$\hat{P}_S = 1548.8 \times \left(\frac{2}{1-R} \right)^{0.3556} \times N^{-0.1129} \quad \hat{P}_S < P_{SS}$$

For other geometries:

$$\hat{P} = \hat{P}_S \times F_{C-F} \times F_{PP}$$

[See Table 21-6]

Figure 21-5: Insert fatigue life: Insert diameter 14 mm



Table 21-7: Insert diameter 17.5 mm: Fatigue correction factors

Multiply the given correction factors (F_{cf}) and (F_{pp}) with the load values from Figure 21-6.

Core height (mm)	Face sheet thickness (mm)	Correction factor, F_{cf}	Partial potting factor, F_{pp}	$(F_{cf} \times F_{pp})$
10	0.1	0.8918	0.6473	0.5772
20	0.1	1.0000	1.0000	1.0000
30	0.1	1.0729	1.1052	1.1858
40	0.1	1.1291	1.1506	1.2291
50	0.1	1.1754	1.1655	1.3700
10	0.2	0.9933	0.6473	0.6430
20	0.2	1.0850	1.0000	1.0850
30	0.2	1.1499	1.1052	1.2710
40	0.2	1.2011	1.1506	1.3820
50	0.2	1.2438	1.1655	1.4496
10	0.3	1.1107	0.6473	0.7189
20	0.3	1.1817	1.0000	1.1817
30	0.3	1.2371	1.1052	1.3673
40	0.3	1.2823	1.1506	1.4754
50	0.3	1.3207	1.1655	1.5393
10	0.4	1.2428	0.6473	0.8044
20	0.4	1.2896	1.0000	1.2896
30	0.4	1.3335	1.1052	1.4738
40	0.4	1.3716	1.1506	1.5782
50	0.4	1.4051	1.1655	1.6377
10	0.5	1.3891	0.6473	0.8991
20	0.5	1.4079	1.0000	1.4079
30	0.5	1.4389	1.1052	1.5903
40	0.5	1.4689	1.1506	1.6901
50	0.5	1.4967	1.1655	1.7444
10	0.6	1.5495	0.6473	1.0029
20	0.6	1.5364	1.0000	1.5364
30	0.6	1.5528	1.1052	1.7162
40	0.6	1.5738	1.1506	1.8108
50	0.6	1.5952	1.1655	1.8593
10	0.7	1.7243	0.6473	1.1161
20	0.7	1.6751	1.0000	1.6751
30	0.7	1.6751	1.1052	1.8513
40	0.7	1.6861	1.1506	1.9400
50	0.7	1.7005	1.1655	1.9820
10	0.8	1.9144	0.6473	1.2391
20	0.8	1.8241	1.0000	1.8241
30	0.8	1.8057	1.1052	1.9958
40	0.8	1.8057	1.1506	2.0776
50	0.8	1.8124	1.1655	2.1123

NOTE Core type - 3/16-5052-.0007p; Core height = 20 mm;
 Face sheet: 2024 aluminium, 0.1mm thick;
 Insert height, $h_i = 9$ mm.

Cyclic loading 3/16-5052-.0007 Core Insert Diameter = 17.5 mm
 Insert height $h_i = 9$ mm; Face sheet material Al 2024; Parameter R

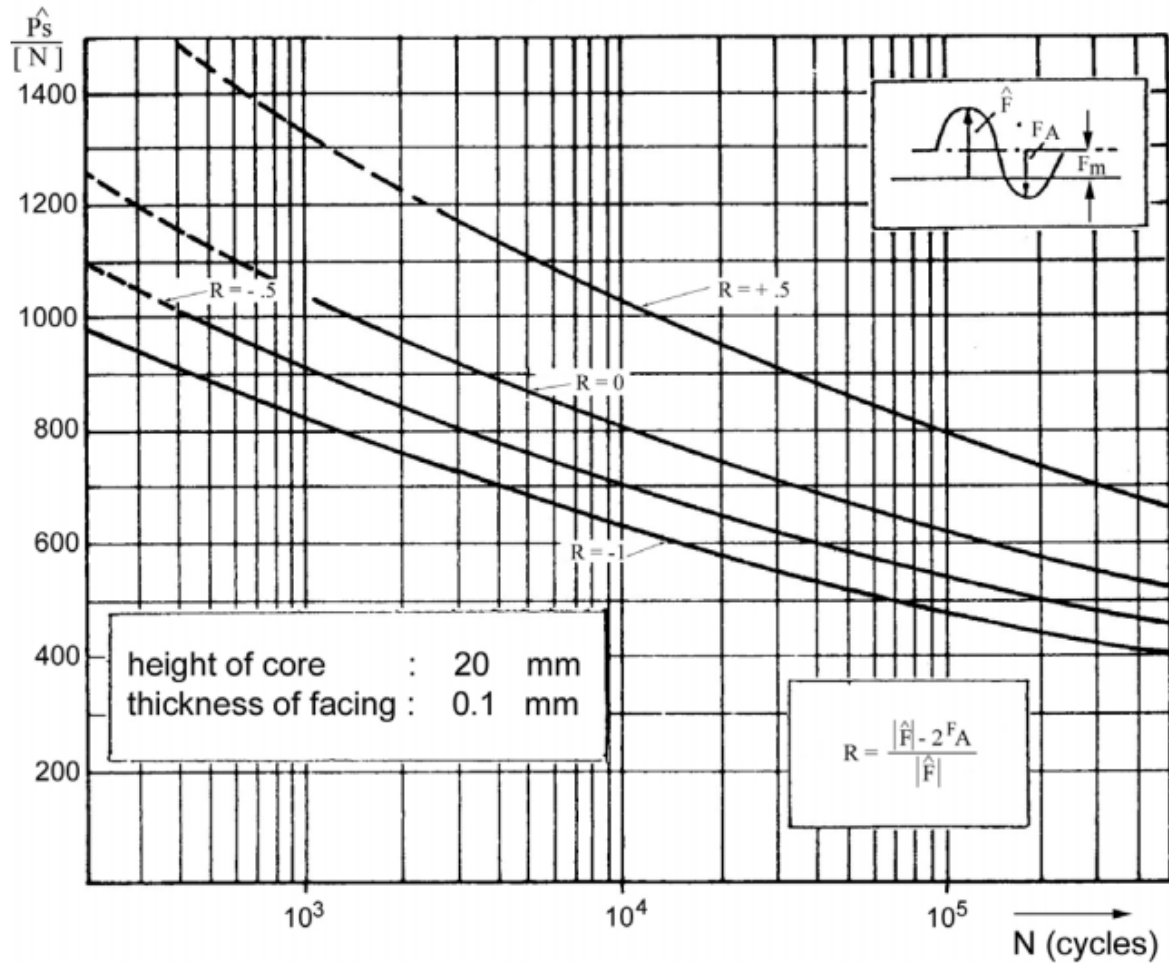

For standard geometries ($f = 0.1$ mm, $c = 20$ mm) as above:

$$\hat{P}_S = 1784.9 \times \left(\frac{2}{1-R} \right)^{0.3556} \times N^{-0.1129} \quad \hat{P}_S < P_{SS}$$

For other geometries:

$$\hat{P} = \hat{P}_S \times F_{C-F} \times F_{PP}$$

[See Table 21-7]

Figure 21-6: Insert fatigue life: Insert diameter 17.5 mm



Table 21-8: Insert diameter 22.5 mm: Fatigue correction factors

Multiply the given correction factors (F_{cf}) and (F_{pp}) with the load values from Figure 21-7.

Core height (mm)	Face sheet thickness (mm)	Correction factor, F_{cf}	Partial potting factor, F_{pp}	$(F_{cf} \times F_{pp})$
10	0.1	0.8897	0.6473	0.5759
20	0.1	1.0000	1.0000	1.0000
30	0.1	1.0741	1.1052	1.1871
40	0.1	1.1312	1.1506	1.3016
50	0.1	1.1783	1.1655	1.3733
10	0.2	0.9800	0.6473	0.6343
20	0.2	1.0754	1.0000	1.0754
30	0.2	1.1423	1.1052	1.2626
40	0.2	1.1949	1.1506	1.3748
50	0.2	1.2385	1.1655	1.4435
10	0.3	1.0832	0.6473	0.7011
20	0.3	1.1605	1.0000	1.1605
30	0.3	1.2191	1.1052	1.3474
40	0.3	1.2664	1.1506	1.4571
50	0.3	1.3064	1.1655	1.5226
10	0.4	1.1986	0.6473	0.7758
20	0.4	1.2548	1.0000	1.2548
30	0.4	1.3035	1.1052	1.4406
40	0.4	1.3447	1.1506	1.5472
50	0.4	1.3804	1.1655	1.6088
10	0.5	1.3256	0.6473	0.8580
20	0.5	1.3577	1.0000	1.3577
30	0.5	1.3952	1.1052	1.5420
40	0.5	1.4295	1.1506	1.6447
50	0.5	1.4603	1.1655	1.7020
10	0.6	1.4640	0.6473	0.9476
20	0.6	1.4690	1.0000	1.4690
30	0.6	1.4940	1.1052	1.6512
40	0.6	1.5205	1.1506	1.7495
50	0.6	1.5459	1.1655	1.8018
10	0.7	1.6138	0.6473	1.0446
20	0.7	1.5885	1.0000	1.5885
30	0.7	1.5996	1.1052	1.7680
40	0.7	1.6176	1.1506	1.8612
50	0.7	1.6370	1.1655	1.9080
10	0.8	1.7755	0.6473	1.1492
20	0.8	1.7161	1.0000	1.7161
30	0.8	1.7120	1.1052	1.8922
40	0.8	1.7207	1.1506	1.9798
50	0.8	1.7336	1.1655	2.0205

NOTE Core type - 3/16-5052-.0007p; Core height = 20 mm;
 Face sheet: 2024 aluminium, 0.1mm thick;
 Insert height, $h_i = 9$ mm.

Cyclic loading 3/16"-5052-.0007 Core Insert Diameter = 22.5 mm
 Insert height $h_i = 9$ mm; Face sheet material Al 2024; Parameter R

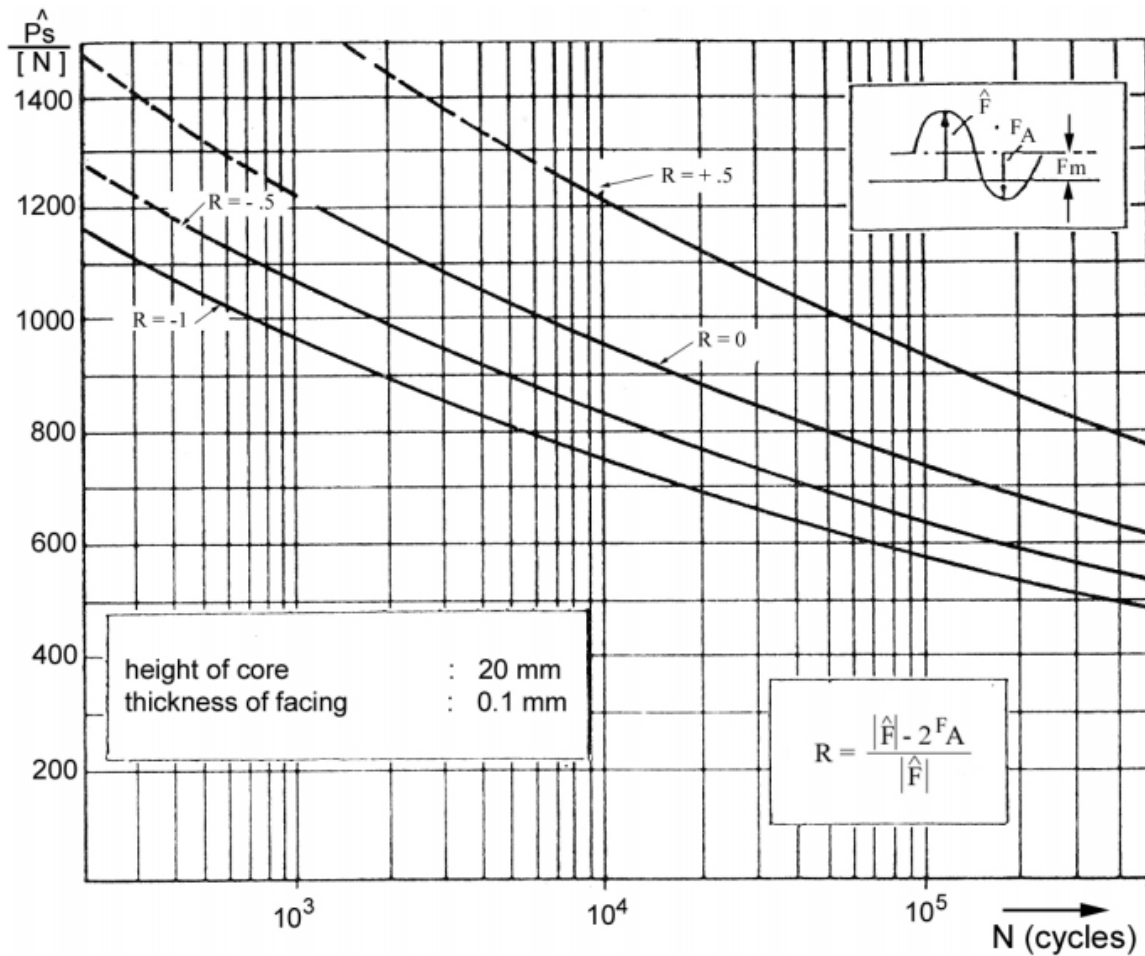

For standard geometries ($f = 0.1$ mm, $c = 20$ mm) as above:

$$\hat{P}_S = 2092.0 \times \left(\frac{2}{1-R} \right)^{0.3556} \times N^{-0.1129} \quad \hat{P}_S < P_{SS}$$

For other geometries:

$$\hat{P} = \hat{P}_S \times F_{C-F} \times F_{PP}$$

[See Table 21-8]

Figure 21-7: Insert fatigue life: Insert diameter 22.5 mm

21.5.5 Insert fatigue life: Non-metallic cores

[See: 21.7]

21.6 Fatigue damage accumulation

According to Palmgreen and Miner, a linear accumulation of damage can be used to assess the fatigue behaviour of inserts under cyclic loads.

$$D_i = \sum \frac{n_i}{N_i} \leq k \quad [21.6-1]$$

Where:

n_i number of cycles applied;

N_i number of cycles applicable up to failure, under load amplitude.

Under constant-amplitude load, an accumulated sum of damage is acceptable provided that the degree of confidence in the fatigue data and the probability of having no failure meet the specification.

A value of $k = 0.25$ is commonly used for initial assessments.

21.7 Non-metallic core

Fatigue data for inserts in sandwich panels using a non-metallic core, e.g. Nomex[®], GFRP; are insufficient to enable a model to be generated that covers sufficient insert and panel configurations.

Figure 21-8 and Figure 21-9 show S/N curves of the worst R -ratio ($R = -1$). These enable a first estimate of the fatigue life in an early design phase, but need supporting tests.

NOTE Nomex[®] and GFRP non-metallic cores are known to be sensitive to severe partial potting, i.e. where $c \gg h_p$.

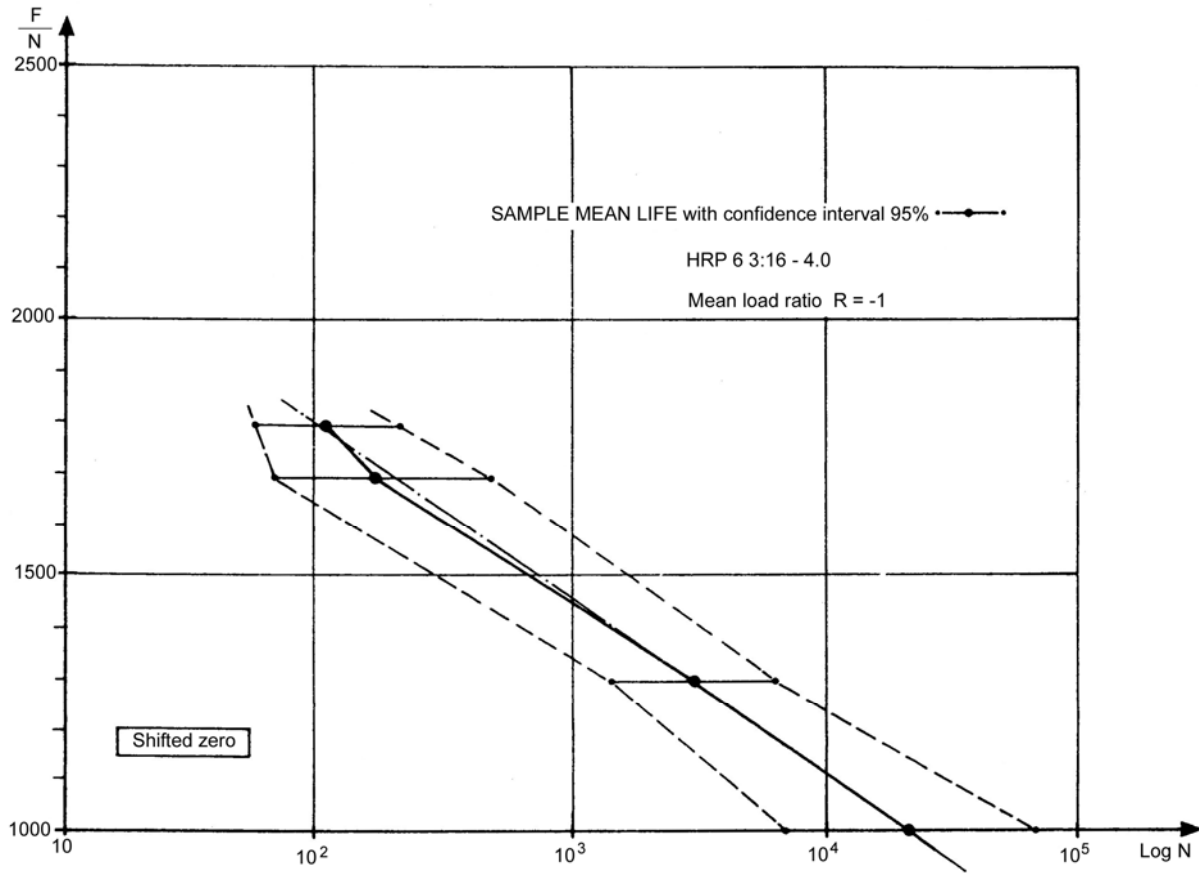

Figure 21-8: Fatigue life: Non-metallic GFRP core

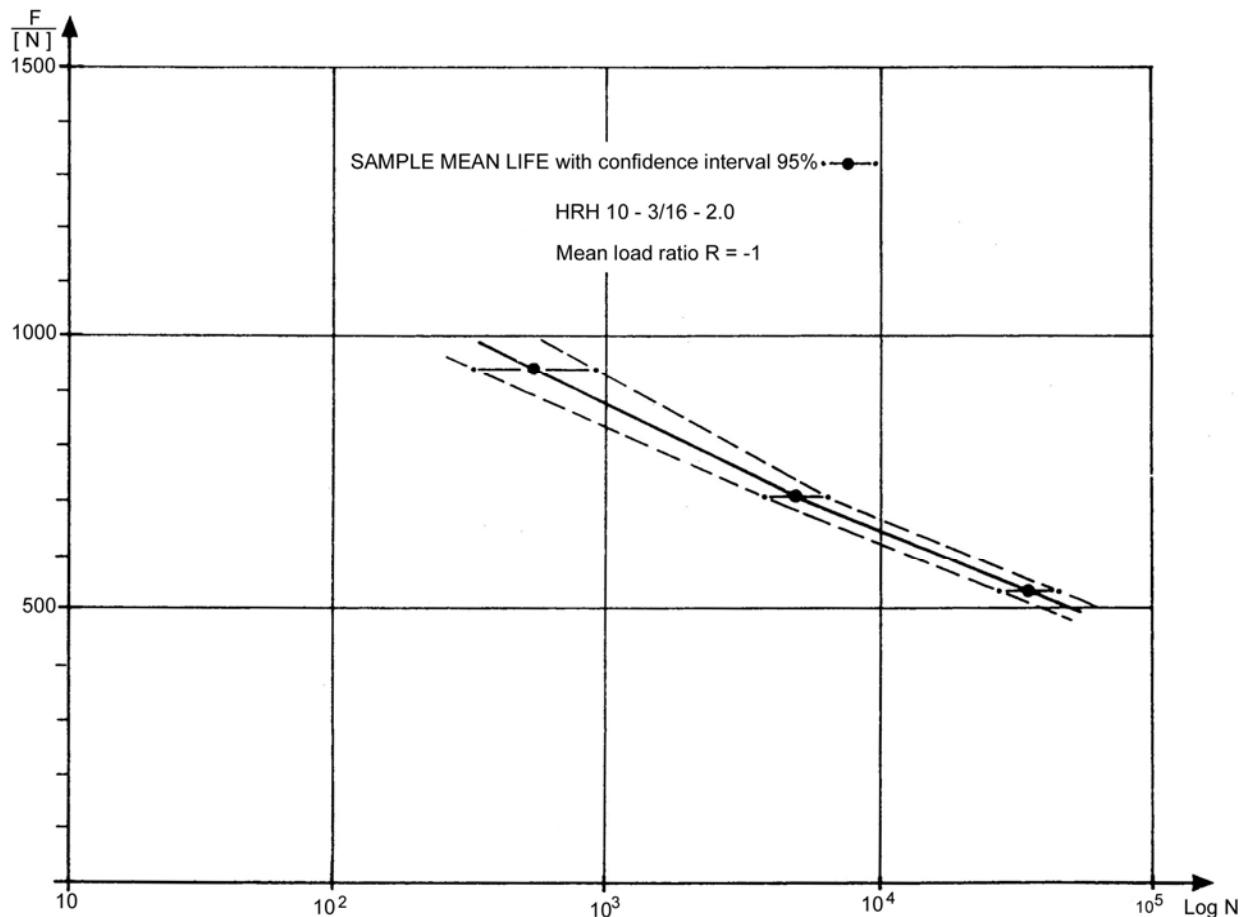

Figure 21-9: Fatigue life: Non-metallic Nomex[®] core

21.8 Composite face sheets

The failure of face sheets on sandwich panels is extremely rare. In general, the failure of composites under cyclic loading is a progressive accumulation of damage rather than a single crack growing to a critical dimension; as seen in fatigue failures of metals, [See: ECSS-E-HB -32-20].

An area that needs consideration is the interface between the composite face sheet and the adhesive bond to the core. Depending on the particular composite used and the lay-up, the resin in the composite can fail before the adhesive bond and lead to first-ply delamination. This effect has been observed in structural adhesive bonds made with some high-performance fibre prepreps, [See: ECSS-E-HB-32-21].

21.9 References

21.9.1 General

[21-1] Standardization of Design Analysis and Testing of Inserts in Non-metallic Structural Sandwich Elements.

Phase I Report, ESTEC Contract No. 440/80/NL/AK(SC).

21.9.2 ECSS standards

[See: ECSS website: www.ecss.nl]

ECSS-E-30 series	Space engineering
ECSS-E-HB-32-20	Structural materials handbook
ECSS-E-HB-32-21	Adhesive bonding handbook
ECSS-Q-ST-70-46	Requirements for manufacturing and procurement of threaded fasteners

22 Environmental effects

22.1 Insert under thermal conditions

22.1.1 General

Thermal conditions can reduce insert capabilities, [22-1].

Figure 22-1 shows the reduction resulting from three different types of thermal conditions, i.e.

- Mechanical loading in a thermal environment;
- Mechanical loading after exposure to a thermal environment;
- Mechanical loading after thermal cycling.

[See also: 22.2 for effects on permissible loads]

22.1.2 Mechanical loading in a thermal environment

The effects can be grouped by temperature, i.e.

- Between -160°C and 40°C , the insert capability is not affected. Tests have shown that the insert capability even increases with decreasing temperature.
- Above 40°C , the insert capability decreases.
- Above 100°C , the tensile strength of potting materials decreases dramatically, as shown in Figure 22-2. This should be avoided when coupled with simultaneous mechanical loading of the insert.

22.1.3 Mechanical loading after exposure to a thermal environment

The effects can be grouped by temperature, i.e.

- Below 100°C , the insert capability is not affected.
- Above 100°C , the insert capability is slightly decreased.

22.1.4 Mechanical loading after thermal cycling

Thermal cycling between $+120^{\circ}\text{C}$ and -160°C can reduce insert capability by 90% of that of an unexposed insert-sandwich system.

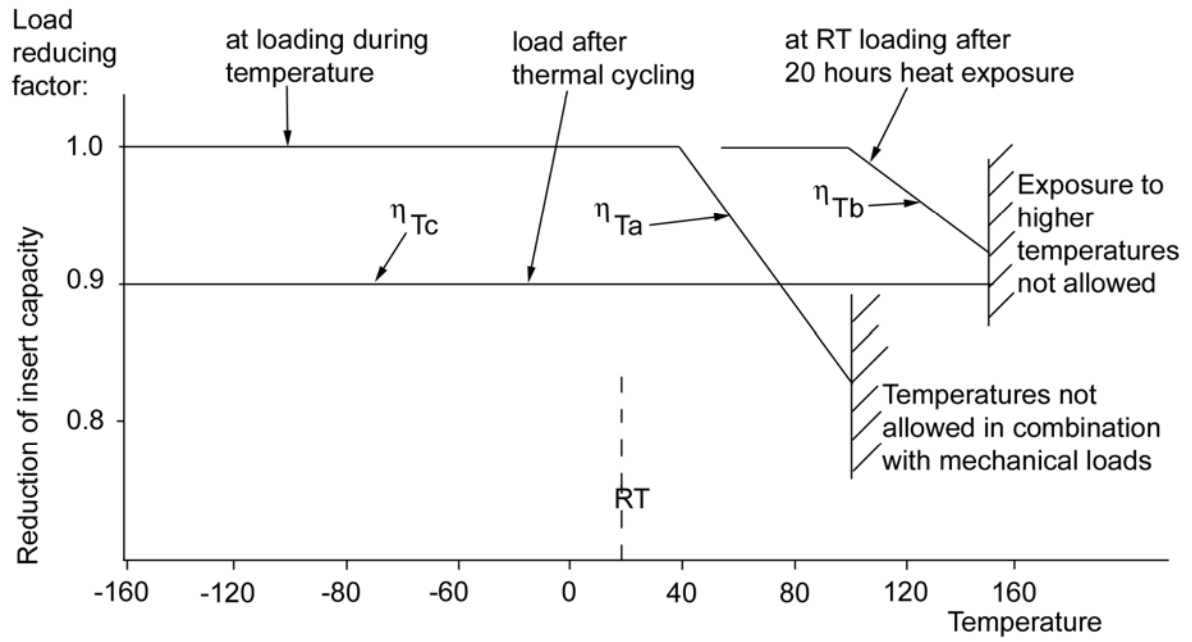

Figure 22-1: Thermal effects: Reduction of insert capability

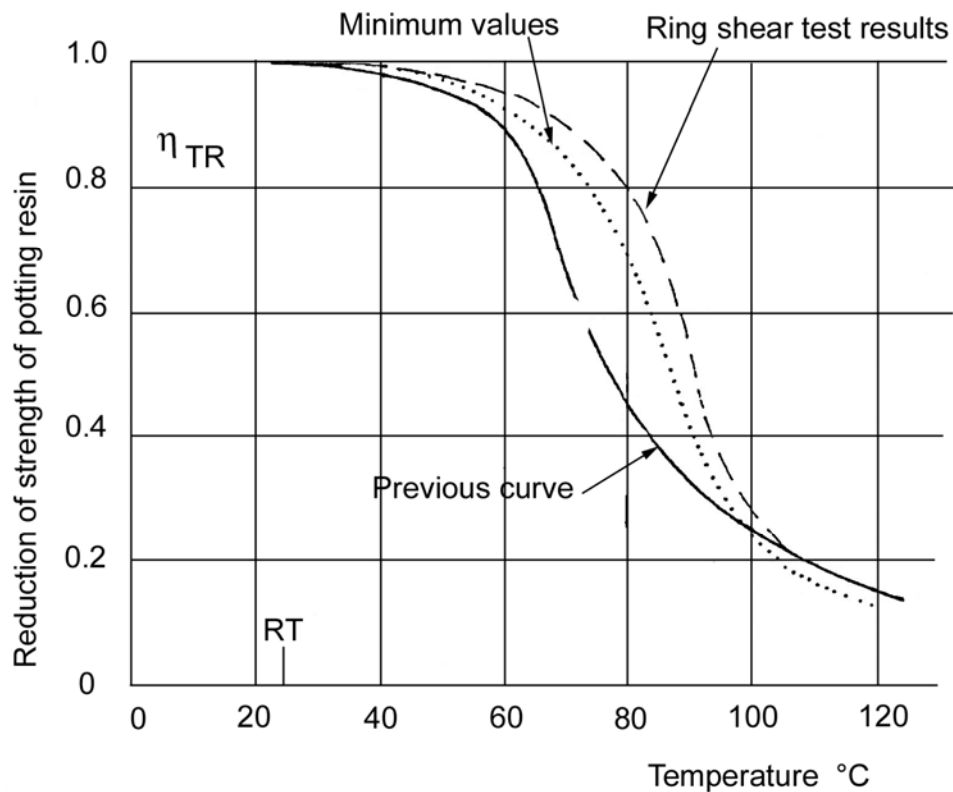

Figure 22-2:

Thermal effects: Reduction of potting resin strength

22.2 Thermal: Reduction of permissible load

22.2.1 Effect on permissible loads

The thermal environment affects primarily the:

- Permissible tensile load, [See: 12.5];
- Permissible compressive load, [See: 13.2];
- Permissible bending load, [See: 15.2].

NOTE The permissible shear and torsional loads are not affected by the thermal environment.

22.2.2 Coefficient of thermal degradation

The reduction of the permissible loads is accounted for by means of a coefficient of the thermal degradation, according to the expression, [22-1]:

$$P_{\eta_{Ti}} = P \times \eta_{Ti} \quad [22.2-1]$$

where:

- $P_{\eta_{Ti}} \hat{=}$ permissible load reduced by thermal environment;
- $P \hat{=}$ permissible load without thermal influence,

[See: 12.5; 13.2; 15.2 12.2]

$\eta_{Ti} \hat{=}$ coefficient of thermal degradation,

Where: $i = c, a, b$ or R

[See: Figure 22-1; Figure 22-2]:

Figure 22-3 summarises the thermal degradation coefficient by the thermal conditions, [See also: 22.1]:

- Mechanical loading in a thermal environment, where:
 - η_{Ta} , the permissible loads are limited by the core properties;
 - η_{TR} , the permissible loads are limited by the properties of the potting compound.
- Mechanical loading after submission to a thermal environment, i.e. η_{Tb}
- Mechanical loading after thermal cycling, where η_{Tc} is valid for 100 cycles in the range -160°C to $+150^{\circ}\text{C}$.

[See also: Figure 22-1; Figure 22-2]

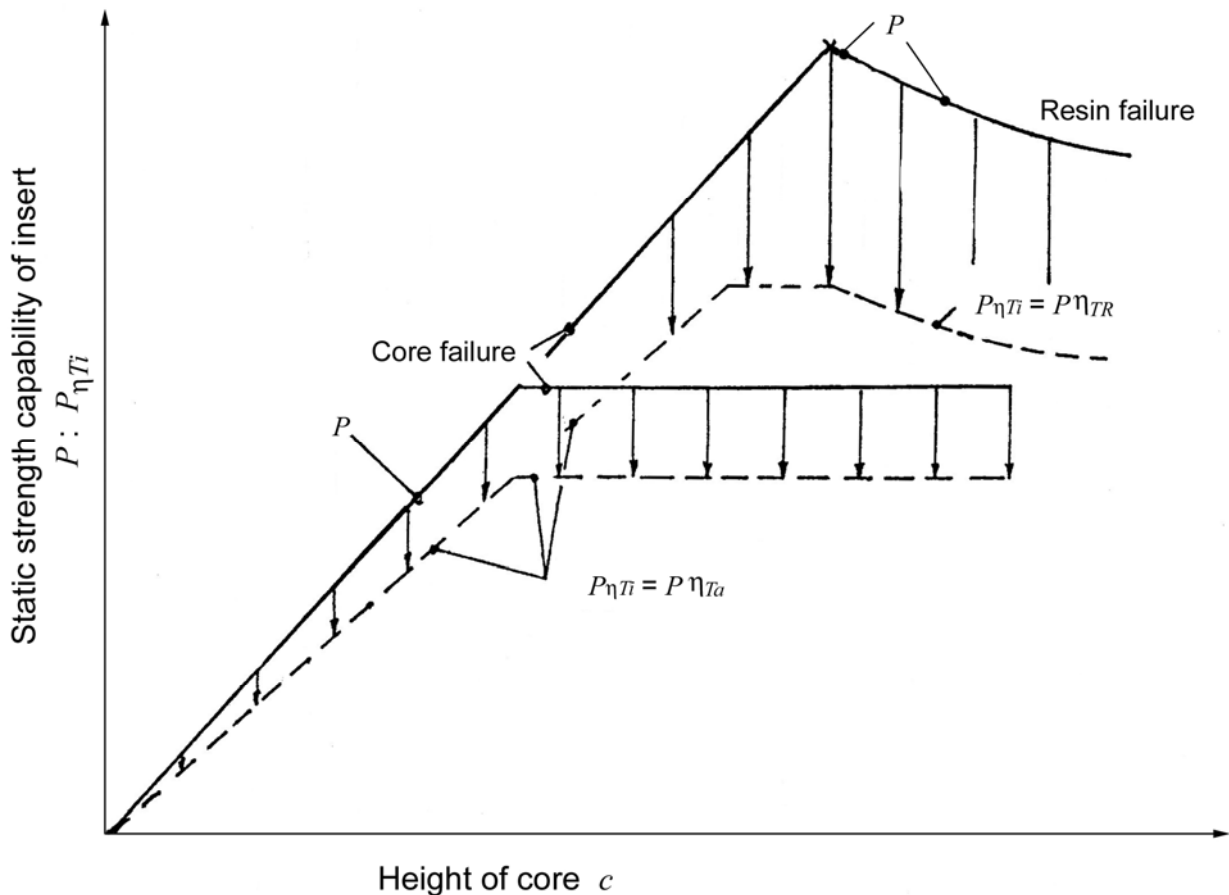

Figure 22-3: Thermal effects: Coefficient of thermal degradation

22.3 Other conditions

Influences of a secondary nature are:

- Humidity, under atmospheric environmental conditions;
- Vacuum, under space environmental conditions;
- Radiation.

[See also: ECSS-Q-ST-70; ECSS-Q-70-71]

Each of these conditions can degrade the potting mass and consequently decrease the insert capability to a certain extent.

The potting mass is usually well-protected by the surrounding structure, often made of aluminium, which means that a deterioration of the potting mass only occurs under extreme conditions.

Particular attention is needed in the selection of a potting mass that is highly-resistant when extreme conditions are expected.

22.4 Composite face sheets

22.4.1 In-plane load under thermal conditions

The reduction in strength of CFRP face sheets under elevated temperature is distinguished with respect to its effect on out-of-plane and in-plane loading, [22-1].

In-plane loads are primarily reacted by the face sheets. Losses are considered directly related to the in-plane load-carrying capability of inserts.

The influence needs careful investigation if the effect of elevated temperatures is covered by standard procedures.

Owing to the different influences on the fibre and matrix, the failure mechanism seems to become non-linear and therefore rather complex.

An extensive investigation using test and analysis is considered necessary in order to provide a simplified, approximate procedure able to handle elevated temperatures.

22.5 References

22.5.1 General

- [22-1] Lassi Syvänen, Kari Marjoniemi, Ari Ripatti, Markku Pykäläinen: Patria Finaviacomp Oy, Finland
 'Analysis models for insert design rules in sandwich panels with CFRP facings'
 Patria report: GS1-PFC-RP-0002 (January 2003)
 ESTEC Contract No. 14076/99

22.5.2 ECSS standards

[See: ECSS website: www.ecss.nl]

ECSS-Q-ST-70 Materials, mechanical parts and processes



ECSS-Q-70-71 Data for the selection of space materials and
processes

23

Manufacturing procedures

23.1 Sequence

23.1.1 General

Figure 23-1 summarises a basic manufacturing sequence for potting standard-types of inserts into existing sandwich panels. It also includes links to appropriate information.

NOTE The manufacturing procedure for non-standard inserts, in particular carbon-fibre tube inserts, is described in Annex A, [See: A.3] and by example in Annex F, [See F.6].

23.1.2 Sandwich panels

Most inserts are potted into existing sandwich panels comprising of metal or composite face sheets and a metal or composite core:

- Metal face sheets are adhesively bonded to the core.
- Composite face sheets can be:
 - adhesively bonded as laminates to the core, or
 - Co-cured with the adhesive layer between the face sheet and the core.

NOTE 1 For the design and manufacturing of sandwich panels, [See: ECSS-E-HB-32-20].

NOTE 2 See also: ECSS website: www.ecss.nl.

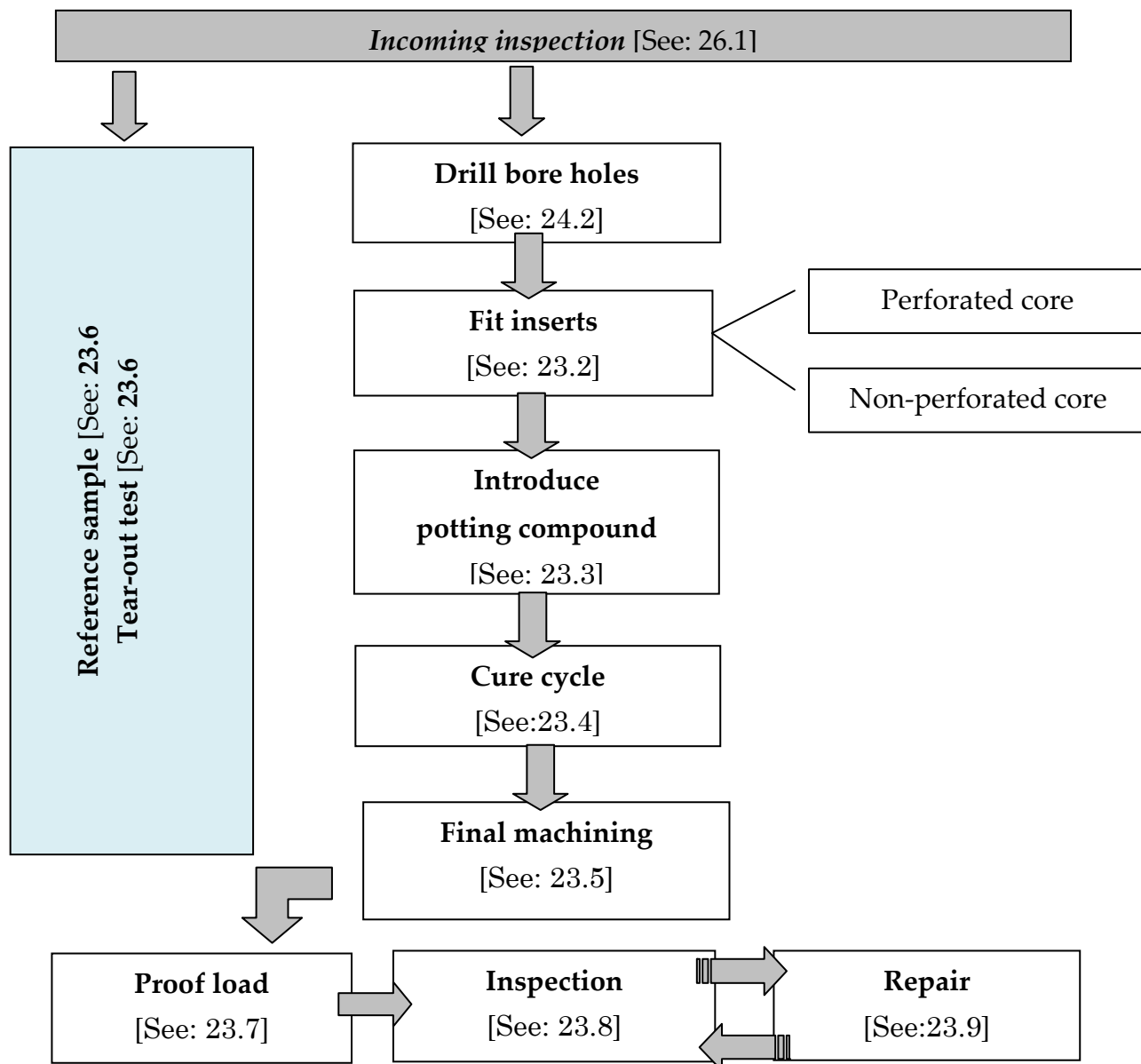

Figure 23-1: Basic manufacturing sequence Fit inserts

23.2.1 General

Inserts are only fitted after the bore holes have been machined, [See: 24.2], inspected and any corrective actions taken to prevent bent or dislocated cell walls impeding the:

- Displacement of trapped air;
- Flow of potting compound.

23.2.2 Positioning

Standard, commercially-available inserts are normally supplied with a positioning tool which aids their placement, i.e. 'flush' or recessed 'sub-flush', [23-16].

Special, non-standard inserts and those positioned 'overflush' or protruding often need a special tool to ensure acceptable flatness of an insert or a group of inserts, [23-16].

[See also: F.6 for carbon-fibre tube inserts]

23.2.3 Perforated core

The protective layer covering the face sheets near the bore hole is removed to the extent needed by the bonding tabs, [23-5].

Inserts need bonding tabs, [23-5], placed such that the injection holes are congruent.

The inserts are then fitted into their respective bore holes by the bonding tabs, so that they are the same with respect to the face sheet.

If the distance between the fitted insert and the face sheet at the bottom of the hole is less than 3 mm, an appropriate amount of insert potting compound is applied to the bottom of the insert prior to its insertion. This enables the loose face sheet to be supported after the insert is fitted.

NOTE 1 Potting compounds are classed as limited shelf-life materials, [See: ECSS-Q-ST-70-22].

NOTE 2 The stated pot life of potting compounds cannot be exceeded, [See: 25.2; 23.3]

If two or more inserts are located at the same position e.g. as shown in Figure 23-2, then particular care is needed to ensure that the opposing insert does not lift during the potting procedure.

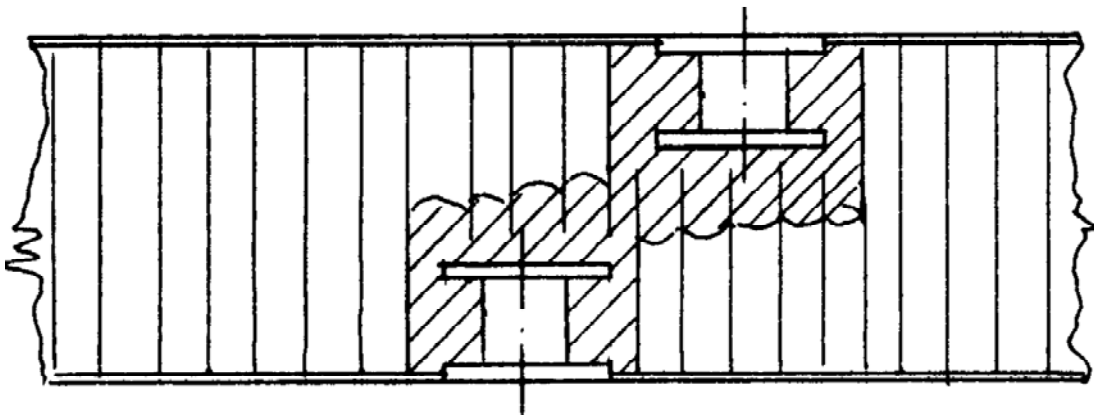

Figure 23-2: Inserts with connected potting mass

23.2.4 Non-perforated core

Non-perforated cores need venting in order to enable the air in the sandwich bore hole to be displaced by the potting compound. Otherwise cells underneath the insert do not fill properly.

Studies of potting compound flow in non-perforated cores have shown that the insert vent hole is 'sealed' by potting compound prior to complete insert potting. Therefore adequate venting of trapped air is essential for successful potting, [23-14].

A venting tube is inserted into one of the insert holes so that it reaches the opposite face sheet, as shown in Figure 23-3

Sizes of venting tube are, typically:

- Inner diameter exceeds 0.3 mm
- Outer diameter, of the order of 1.5 mm

The ends are cut diagonally at an angle of about 45°.

The vent tube can remain in the potting or be removed before curing.

NOTE If the vent tube remains in the potting, it should be made from an acceptable material for space use.

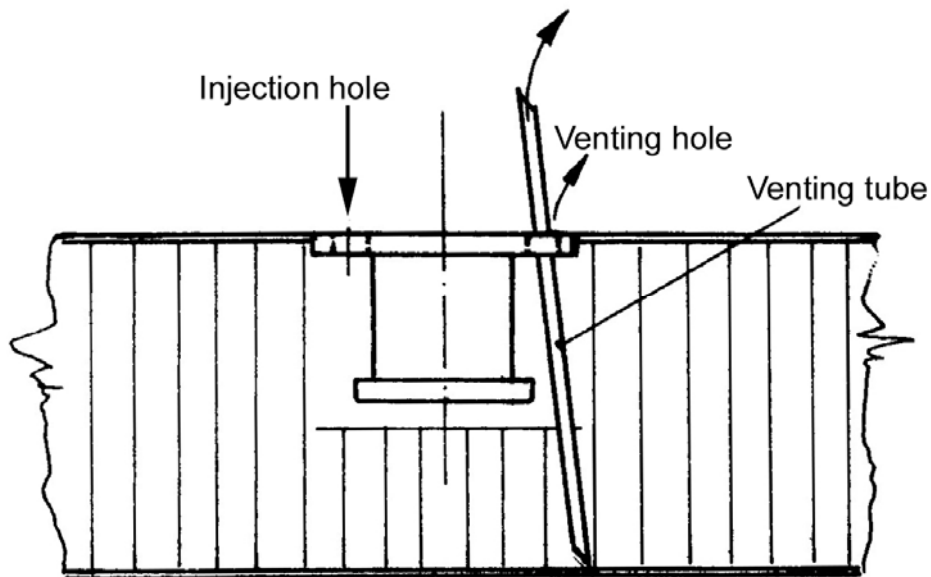

Figure 23-3: Venting of non-perforated core

23.3 Inject potting compound

23.3.1 General

Injection of the insert potting compound is carried out when all the preparation stages are complete and shown to meet with quality control procedures, [See also: 28.1].

For standard types of potted inserts, the applicable steps are:

- Bore holes:
 - drilling, [See: 24.1];
 - inspection, [See: 28.2].
- Insert pretreatment, [See: 25.1].
- Fitting inserts, [See: 23.2].
 - Perforated cores;
 - Non-perforated cores, with additional venting.
- Mixing potting compound, [See: 25.2].

[See also: F.6 for non-standard carbon-fibre tube inserts]

23.3.2 Process

23.3.2.1 Single-sided injection

The potting compound is injected under pressure into one of the two holes in the bonding tabs until it is seen to leave the opposite (vent) hole.

A strand of potting compound about 6 mm long appearing from the vent hole indicates that the bore cavity and the surrounding honeycomb cells are well filled.

NOTE Pot life cannot be exceeded, [See: 25.2].

Potting resin can first be injected through small holes in the face sheet prior to injecting through the insert flanges, [23-16].

23.3.2.2 Double-sided injection

Where it has proven difficult to ensure full and proper potting from one side by single-sided injection, potting compound can be injected from both sides of the panel (double-sided injection).

Such a technique was used successfully in the ASAP 5 project for special through-the-thickness inserts installed in thick cores, i.e. exceeding 60 mm height, [23-16].

23.3.3 Flow characteristics

23.3.3.1 General

Factors affecting the flow of potting compound around inserts in sandwich panels include:

- Material characteristics, e.g. viscosity, [See: 7.1; 25.3]
- Bore hole geometry, [See: 23.2; 28.2].

23.3.3.2 Fully potted inserts

The flow characteristics of potting compound around 'through-the -thickness' or fully potted inserts, i.e. where insert height is the same as the core height ($h_i=c$), indicate that the cavity is filled from the bottom upwards. This normally provides correct coupling between the panel structure and the insert, [23-14].

23.3.3.3 Partially potted inserts

Where the insert height is less than the core height ($h_i < c$), i.e. partially potted, the flow characteristics of the potting compound around and under the insert are balanced to ensure adequate potting.

The volume under the insert does not fill fully if the flow around the insert is faster than the flow under the insert.

The volume between the insert flange and the panel structure does not fill fully if flow is faster under the insert than around it.

A balanced flow (around and under the insert) is largely dictated by the bore hole depth to insert height, [23-14].

23.3.3.4 Perforated core

During the filling process, the perforations enable venting of air trapped within the bore hole during potting, [23-14].

23.3.3.5 Non-perforated core

A difference in the flow of potting compound around and under inserts can lead to the vent hole (at top of insert) becoming blocked before potting is complete. Any air remaining in the bore hole cannot be displaced and this causes voids, [23-14]. Hence, additional venting is necessary, [See: 23.2].

23.4 Cure cycle

23.4.1 General

When all the inserts have been correctly potted in the sandwich panel, the potting compound is then cured.

The cure cycle used largely depends on the chemical formulation of the resin used for potting and whether the resin or assembly can be cured at elevated temperature without causing damage, e.g. thermally-induced damage to composite face sheets; adhesive bond between core and face sheets; cores. In cases where the inserts are co-cured, the potting resin is subjected to the same cure cycle as the rest of the assembly.

23.4.2 Resin system: Shur-Lok SLE 3010

[See: 25.2]

23.4.3 Potting foam: Lekutherm X227+T3

[See: 25.2]

23.4.4 Other resin systems

[See: 7.1]

23.5 Corrective actions

23.5.1 General

Once an insert is potted into a sandwich panel, there are limited opportunities to correct any errors. This is why proper manufacturing processes, and their control, are essential.

23.5.2 Final machining

23.5.2.1 General

The processes described are used when a potted insert is found to deviate from the stated requirements during the manufacture. Final machining processes can be stipulated as part of the overall processing, rather than solely as corrective actions. For example, machining of flanged inserts to improve flatness, change friction co-efficient and prevent stress concentrations between attachment points and panels, [See also: Table 5-1; 10.3].

23.5.2.2 Protruding inserts

Protruding inserts can be machined back to the face sheet surface.

NOTE 1 Typical machining tolerance: -0.03 mm.

NOTE 2 The face sheet cannot be damaged during final machining.

23.5.2.3 Angled inserts

Inserts that are not normal to the panel surface can only be corrected by machining provided that the insert shaft is not damaged, [23-14].

23.5.2.4 Insert protective coating

Machined surfaces of fitted inserts need a protective coating, This is applied using a chemical oxidising process, e.g. a non-electrolytic process, such as Alodine® 1200 (identification number 1101), [23-6]. Using this surface treatment results in an electrically conductive, chromated (mixed-metal, chromium-oxide) film, typically less than $1\mu\text{m}$ thick.

[See also: ECSS-Q-70-71]

NOTE Any penetration of the oxidising chemical into the insert thread should be prevented.

23.6 Reference sample

23.6.1 General

Reference (or witness) samples assess the potting process. The reference sample is produced at the same time as the manufactured assembly and undergoes all the same processes, e.g. machining, potting, cure. The potting process is evaluated by a vertical insert pull-out strength test. This is a destructive mechanical test that tears the insert out of the reference sample, [See also: 27.3].

23.6.2 Materials

The reference sample is made from exactly the same materials used in the manufactured assembly, i.e. the same:

- Sandwich;
- Insert;
- Potting material.

23.6.3 Manufacture

Reference samples are:

- Potted at the same time as the production sandwich panel;
- Cured together with the production sandwich panel.

NOTE All reference samples are clearly identified, e.g. by drawing number; marking with adhesive tape.

23.6.4 Number of samples

The number of reference samples, n needed depends on their criticality, i.e.:

$$n_{\text{standard}} = 1 + \frac{N_{\text{ges}}}{100} \quad [23.6-1]$$

$$n_{\text{safetycrit}} = 2 + \frac{N_{\text{ges}}}{10} \quad [23.6-2]$$

where:

n rounded up to whole number of samples;

N_{ges} number of potted inserts produced per day, i.e. 'daily charge', from the same mix, [23-17].

23.6.5 Pull-out strength test

The vertical pull-out strength is determined not earlier than 2 days after potting.

The other conditions are:

- Test specimen, as shown in Figure 23-4.
- Load application rate 2 mm/min, typically, [See: 27.3].
- Test record, a force-deflection curve is used to determine the pull-out strength.

NOTE Pull-out of an insert 1 mm to 2 mm above the face sheet is considered adequate.

[See also: 27.3]

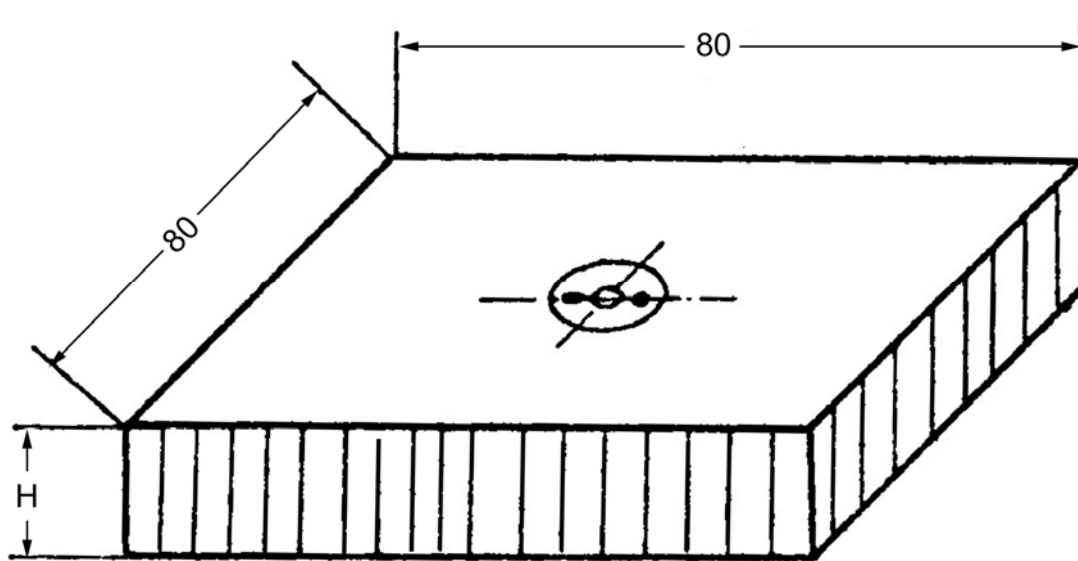

Figure 23-4: Reference sample: Pull-out strength test specimen Proof load

Proof loading of inserts in flight-destined items can be stipulated for high-reliability applications. The level of proof loading, i.e. how much higher than limit load, has been investigated, [23-13].

NOTE Proof loading and load-levels conform to those defined within the structural design documentation.

23.8 Inspection

The basic set of inspection criteria for standard, potted inserts are:

- Machined bore hole for insert:
 - actual diameter;
 - actual depth;
- Check for detachment of face sheets from the honeycomb core;
- Cleanliness of the bore hole prior to the potting;
- Insert position, with respect to sandwich face sheet:
 - flush: maximum tolerance -0.03 mm;
 - Perpendicular: maximum tolerance: $\pm 0.5^\circ$.
- Filling of the insert injection and venting holes with potting compound.

Other inspection criteria can be stipulated for non-standard inserts.

NOTE All inspection criteria are checked, documented and compared with the requirements to establish if potted inserts are acceptable or unacceptable.

23.9 Repair

23.9.1 General

The repair of inserts is occasionally necessary to:

- Replace a damaged insert;
- Reinforce a damaged core surrounding an insert;
- Replace an insert with another, e.g. increase strength;
- 'Reposition' an insert, e.g.
 - original slightly misplaced;
 - fixing point changed.

The repair process used depends on whether the core and face sheets are damaged or not. The processes described apply to standard-type inserts. Non-standard types can need different repair methods.

23.9.2 Undamaged core or face-sheet

If the surrounding sandwich core and face sheet are undamaged, a damaged insert can be replaced reliably by an insert of the same dimensions, i.e. $d_{i\ old} = d_{i\ new}$; $h_{i\ old} = h_{i\ new}$.

23.9.2.1 Process

- Drill out old insert;
 - NOTE Avoid overheating and high drilling forces; drill diameter: $d_i - 2\text{mm}$.
- Extend bore hole by milled undercut, as shown in Figure 23-5;
- Extend bore hole by puncturing cured potting compound and unfilled core cells, Figure 23-5
- Remove residual upper flange of old insert with tweezers;
- Ream bore hole: tolerance 0 to +0.03 mm;
- Apply appropriate amount of potting compound, i.e. to fill the hole and support the lower flange of the new insert;
- Fit new insert, [See: 23.2];
- Pot new insert, [See: 23.3].

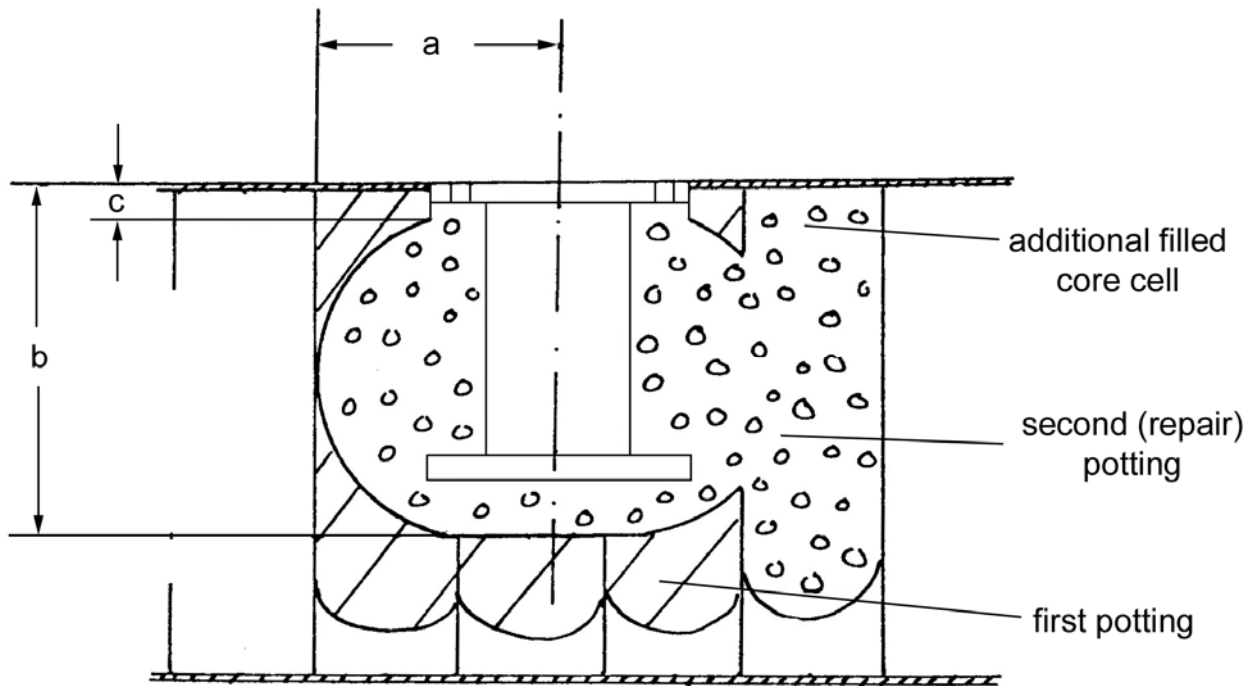

Repair dimensions:

$$a = r_i + \frac{2}{3} S_c^{+1.0}$$

$$b = h_i + 3.0^{+1.0}$$

$$c = 1.5^{+1.0}$$

Figure 23-5: Insert repair: Geometry

23.9.3 Damaged core and face sheet

Inserts with damage to the surrounding sandwich panel, need reinforcing in the damage zone.

A suitable method is the injection of liquid resin into each cell of the core through small holes drilled in the face sheets.

For inserts near the edge of a sandwich panel, the resin can be injected from the side of the panel.

23.9.4 Replace or reposition inserts

This applies to:

- Slightly misplaced inserts to be replaced by a larger diameter;
- Replacement with a stronger insert, i.e. with a larger diameter with or without increased height, [See: 12.6].

After drilling out the old insert, any remaining cured potting compound needs reworking to guarantee a positive connection, [See: Figure 23-5

23.10 Defects

The majority of defects can be avoided by the creation, strict adherence to, and control of all process procedures, covering:

- Incoming inspection:
 - Honeycomb, [See: 26.2];
 - Resin, [See: 26.3].
- Manufacture:
 - Processes, [See also: Figure 23-1];
 - Mechanical tests, [See: 27.1; 29.1; Annex H];
 - Non-Destructive test, [See: 27.1].
- Quality assurance:
 - Bore hole, [See: 28.2];
 - Potting, [See: 28.3];
 - Core, [See: 28.4].

The effects of some defects on insert capability are described, along with any corrective actions taken, [23-16].

[See also: 23.5]

23.10.1 Poor storage of potting compound

Inadequate storage of potting compound components, i.e. base resin, hardeners, catalysts, can degrade the properties of the cured material. This is reflected in lower than expected insert capabilities.

NOTE The component parts of potting compounds are classed as limited shelf-life materials and measures for their control are stipulated in ECSS-Q-ST-70-22.

Table 23-1 gives an indication of the insert tensile property loss associated with bad storage of a potting compound for, [23-16]:

- Core: honeycomb 4-40 AG5, height = 40 mm;
- Face sheets: 7075-T6 (AZ5GU), thickness = 1 mm;
- Potting compound: SLE3010, RT cure;
- Insert: Shur-lok® SL601 M6-15.9S: 17.4 mm dia.; 15 mm height.

Table 23-1: Insert capability: Effect of poor storage of potting compound

Storage	Tensile load ⁽¹⁾		No. of samples
	Average (N)	Minimum (N)	
Good	6830	6080	5
Poor	5575	4190	7
NOTE (1) Single insert test.			

23.10.1.1 Corrective action

The inserts and the potting compound were removed and replaced by new ones.

NOTE As more cells were opened in the removal and refitting process, the effective potting radius increased, and so did the load-bearing capability, [23-16].

23.10.2 Poor potting compound distribution

If the potting compound is not spread evenly or consistently around the insert, the tensile strength can be reduced severely, [See: 28.3]. It can occur if the control procedures for the bore hole are inadequate, and cells are not open to the flow of injected potting compound, [See also: 24.4; 23.1]

Table 23-2 indicates the loss of tensile strength that can occur due to poor potting for, [23-16]:

- Core: honeycomb 3-50 AG5, height = 12mm
- Face sheets: CFRP Brochier 108-42-G814-NT, 0.36 mm thick
- Potting compound: - not stated -, RT cure
- Insert: 'through-the-thickness' , [See also: Schematic in Table 23-2]

Table 23-2: Insert capability: Effect of poor distribution of potting compound

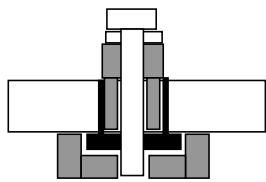
	Insert Potting	Pull-out tensile load Average (N)	No. of samples
	Fully potted	6040	10
	Poor ⁽¹⁾	624	7
NOTE (1) Bad injection of potting compound; adhesive only present between the flange and the face sheet, [23-16].			

23.10.3 Poor positioning of insert

23.10.3.1 Insert not flush

If the insert is not flush with the surface of the panel, the shear load capability can be affected, e.g. reduced or inconsistent.

Table 23-3 indicates the effect of poor insert positioning on the shear load, compared with the calculated value for, [23-16]:

- Core: honeycomb 4-40 AG5, height = 23 mm;
- Face sheets: AU2GN, thickness = 0.5 mm;
- Potting compound: SLE3010, RT cure;
- Insert: Shur-lok[®] SL607 M5-10S, 11.48 mm dia.; 13.07 mm height; partially potted.

Table 23-3: Insert capability: Effect of poor positioning of insert

Insert Position	Shear load (N)	No. of samples
Good	3670	calculated
Poor	2760 3788	2

23.10.3.2 Angled insert

If the insert is at an angle with respect to the panel surface or to the equipment (or structure) to be bolted to it, then the load-transfer across the interface is uneven. The insert can become over-loaded and can deform, [23-16].

NOTE This was noted in the ARIANE 4 Equipment Bay at one equipment fixing point.

23.10.4 Oversized bore hole size

Bore holes in sandwich panels are dimensioned for the particular insert to be used, with appropriate (low) dimensional tolerances. If the bore hole is too large, then the shear load capability decreases.

Table 23-4 indicates the reduction of shear load associated with an oversized bore hole for, [23-16]:

- Core: honeycomb 4-40 AG5, height = 23 mm;
- Face sheets: AU2GN, thickness = 0.5 mm;
- Potting compound: SLE3010, RT cure;
- Insert: Shur-lok® SL607 M5-10S, 11.48 mm dia.; 13.07 mm height; partially potted.

Table 23-4: Insert capability: Effect of oversized bore hole

Hole diameter (mm)	Shear load (N)	No. of samples
11.48	2760 3788	2
12.4	600 800	2

23.11 References

23.11.1 General

- [23-1] 'Inserts for sandwich structures, closed, self-locking with floating and removable nut, screw securing'
 ENN 366 (MBB-ERNO)
- [23-2] -Title not stated-
 ENN 379 (MBB/ERNO)
- [23-3] 'Inserts for sandwich structures closed, self-locking'
 ENN 386 (MBB/ERNO)
- [23-4] 'Inserts for sandwich constructions, closed, with screw locking helical coil insert'
 ENN 398 (MBB/ERNO)
- [23-5] 'Bonding tabs'
 ENN 34602 (MBB/ERNO)
- [23-6] 'Designation of the surface treatment'
 LN 9368 (Beuth-Verlag, Germany)
- [23-7] 'Standard climate conditions'
 DIN 50014 (Beuth-Verlag, Germany)

- [23-8] 'Instructions for the issuance of failure messages and failure elimination'
RL 0008021
- [23-9] SLE 3010 7-29-70: Product data
- [23-10] Lekutherm X227 + T3: Processing instructions
Bayer GmbH
- [23-11] 'Application of toxic, volatile, non-flammable solvents for cleaning
purposes'
UVV 11.2 (VBG 87)
- [23-12] 'Application of adhesive with easily volatile, flammable solvents'
VBG 81
- [23-13] 'Standardization of Design Analysis and Testing of Inserts in Non-
Metallic Structural Sandwich Elements, Phase I' Report No.
440/80/NL/AK(SC)
- [23-14] 'Reevaluation of Potting Procedure - Final Report', July 1990. MBB-ERNO
(Bremen).
- [23-15] ESTEC Contract No. 7830/88/NL/PH(SC)
- [23-16] 'MMS Contribution to ESA Insert Design Handbook'
Matra Marconi Space Report No. NT/102/BG/355013.96 (December 1996).
- [23-17] ESTEC/MMS-UK Private communication (April 1999).

23.11.2 ECSS standards

[See: ECSS website: www.ecss.nl]

ECSS-Q-ST-70-22 Control of limited shelf-life materials

ECSS-Q-70-71 Data for the selection of space materials and processes

24 Sandwich panel machining

24.1 Drilling bore holes

The two main steps in installing a standard insert element into a sandwich panel are:

- Bore hole drilling, [See: 24.2; 24.4].
- Potting of inserts, [See: 25.2].

NOTE For non-standard inserts, potting can be replaced by an equivalent procedure, [See: A.3; F.6].

Processes for drilling bore holes in honeycomb sandwich panels for potted inserts should avoid damage to the surrounding core, [24-1], [24-2].

NOTE 1 The manufacture of sandwich panel should meet the relevant standards, e.g. MIL HDBK 23, [See also: ECSS-E-ST-32-20].

NOTE 2 For additional effects of core strength on insert capabilities, [See also: 6.5 for core shear strength; 26.2 for core incoming inspection testing].

24.1.1 Bore hole geometry

Bore hole geometry has a strong influence on the flow of the potting compound around the insert. This in turn affects the insert strength capability.

Three important values related to geometry are the:

- Effective potting radius, [See: 7.3]
- Real potting radius, [See: 7.4]
- Potting height, [See: 7.5]

24.1.1.1 Diameter

The bore hole diameter is defined by the particular insert diameter to be used.

NOTE No large tolerances are acceptable.

24.1.1.2 Depth

The bore hole depth should be optimised because it defines the free-volume under an insert, which affects the flow of potting compound, [24-2].

24.2 Processing

Drilling of bore holes for inserts can be achieved by two different methods using 'single' or 'combined' tools, i.e.:

- Drill face sheet then cut honeycomb core.
- Drill face sheet and honeycomb core.

NOTE Lubricants or coolants cannot be used during any drilling or cutting processes.

All drilling processes should avoid damage to the surrounding core. Core damage can occur during the drilling process when the core is stressed in a direction other than its high-stiffness (normal) direction.

The increasing demands for placing (and easy replacement) of brackets and boxes on sandwich panels, using inserts, means that the precision provided by 'coordinate drilling' is replacing the previous 'sequence drilling' processes, [24-2].

24.2.1 Combined tool

Figure 24-1 shows a combined drill and punch tool and its operation principle.

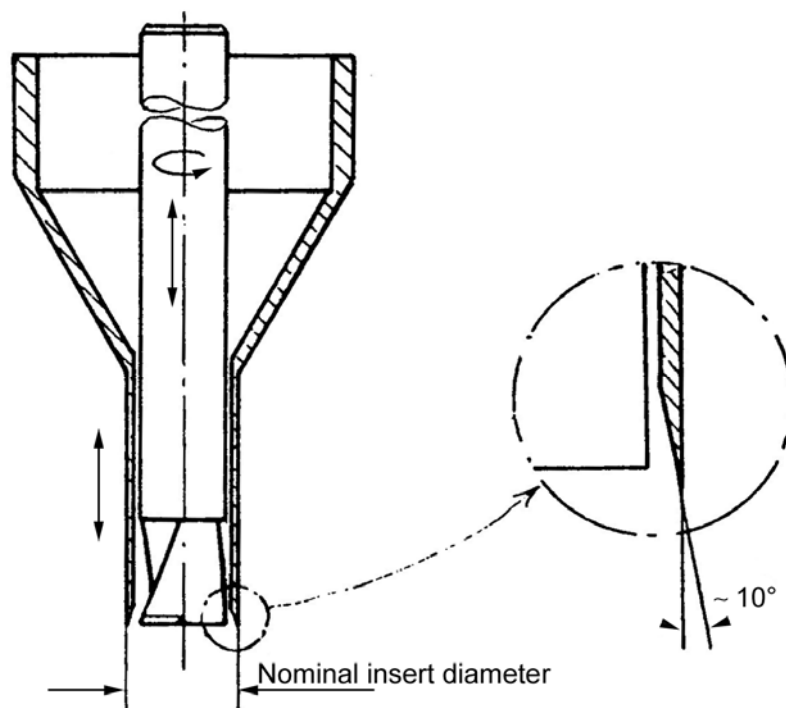

Figure 24-1: Sandwich panel machining: Combined drill and punch tool

24.2.2 Single tools

Figure 24-1 shows a series of individual tools involved in machining bore holes:

- Drill to produce a centre bore into the face sheet (1);
- Special drill for cutting the face sheet bore hole (2);
- Punching tube for non-rotating core cutting (3);
- Combination punching tube with inner core milling tool (4);
- Inner milling tool; shown separately (5).

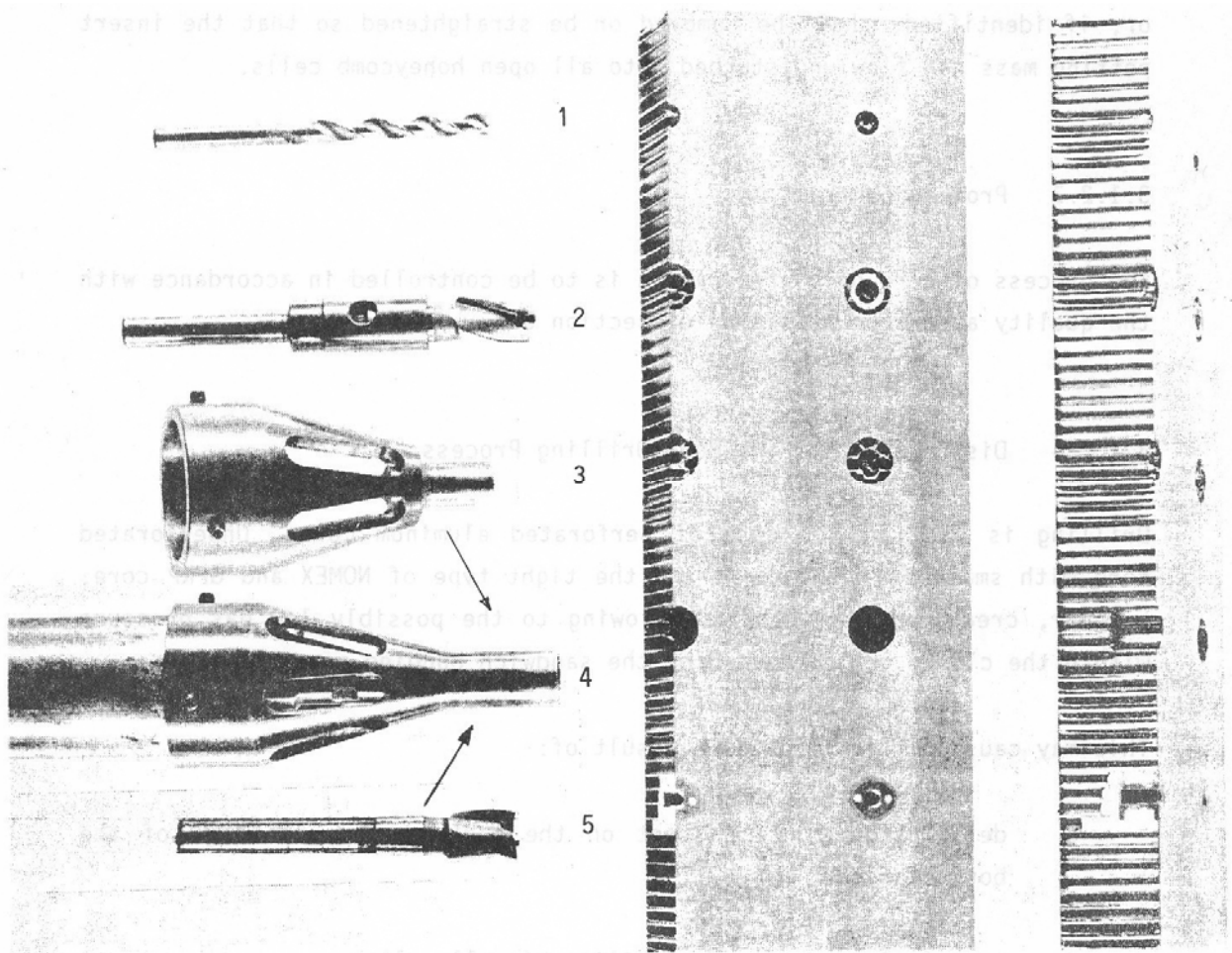

Figure 24-2 Sandwich panel machining: Series of single tools and their uses

24.2.3 Drill face sheet then cut honeycomb core

24.2.3.1 Drilling bore holes in face sheet

NOTE Lubricants or coolants cannot be used during any drilling or cutting processes.

The insert location is fixed by a centre bore of 6 mm or 8 mm diameter.

A special drill is used that only cuts the outer diameter of the bore. This produces a disc in the face sheet; as shown in Figure 24-2(No. 2).

NOTE When a 'coordinate drilling machine' is available, the special drill can be used without setting a centre bore.

The face sheet disc is then pulled off the core with a pair of tweezers.

NOTE The tolerances of the bore hole in the face sheet are within 0 to +0.03 mm of the nominal insert diameter.

24.2.3.2 Cutting of honeycomb core

A punching tube (maintained perpendicular to the sandwich plate) is used to cut a cylindrical part of the core to the necessary depth.

NOTE 1 The bore hole depth exceeds the insert height by 3 mm to 4 mm.

NOTE 2 The depth is largely determined by the potting height, [See: 7.5].

Simultaneously, a drill acting inside the tube removes the cut cylindrical core with the tube acting as a drill-jig.

NOTE This technique ensures that process control is met reliably, [See: 24.4].

After machining, any bent or dislocated core cells are removed or straightened so that the insert potting compound can flow undisturbed into all open honeycomb cells.

24.2.4 Drill face sheet and honeycomb core

NOTE Lubricants or coolants cannot be used during any drilling or cutting processes.

A drill (diameter: $d_i - 2\text{mm}$), maintained perpendicular to the sandwich plate, produces a hole of the necessary depth.

NOTE The depth is largely determined by the potting height, [See: 7.5].

Then, a reamer is used to extend the bore hole to the nominal insert diameter.

NOTE The tolerances of the bore hole in the face sheet are within 0 to +0.03 mm of the nominal insert diameter.

After machining, any bent or dislocated core cells are removed or straightened so that the insert potting compound can flow undisturbed into all open honeycomb cells.

24.2.5 Coordinate drilling machines

Processes using 'coordinate drilling' should avoid the two commonly found problems:

- Bending core foils during cutting;
- Tendency to produce conical holes (smaller diameter at the bottom) rather than the necessary parallel bore.

As for 'sequence drilling' processes, any bent or dislocated core cells are corrected after drilling.

Conical holes arise due to the reduced supporting effect of the bonded face sheet on the core at increasing hole depth.

24.3 Composite face sheets

The machining processes and tools used for composite materials are different from those used on metals. This is especially true when machining very thin high-performance composites, such as those used as face sheets on sandwich panels.

Different machining processes are applied to non-metallic cores, e.g. Nomex or GFRP honeycomb or foams, [See also: 24.4].

In addition to the precautions taken to avoid deformation and damage to the core, extreme care is exercised not to damage the face sheets, either locally around the machining site or globally, e.g. by excessive clamping forces, [See also: 24.4].

Relevant standards provide guidance on machining composites, [See: MIL-HDBK-17 and ECSS-E-ST-32-20].

24.4 Process control

Bore hole machining processes are included in the overall quality assurance plan and subsequently controlled, [See: 28.2].

24.4.1 Potential problems

24.4.1.1 Bore hole geometry

[See: 24.2 for comments on conical holes]

24.4.1.2 Cores

Perforated aluminium cores are easy to drill.

Un-perforated core with thin foils and the 'tight' type of Nomex[®] and GFRP core can create problems due to the possible low gas pressure within the closed cells; caused by the sandwich bonding process. This can result in:

- Deformation of the face sheet on the backface across the bore diameter;
- Core failure due to instability of cell walls.

Although it is difficult to avoid such distortions, e.g. by venting with the aid of a needle, it is useful to know that they are likely to occur.

24.4.1.3 Composite face-sheets

High-performance composites can delaminate if incorrect tools and machining processes are used. The usual approach for a laminate is to provide rigid support behind it during machining. This limits break-out and delamination at and around cut edges, [See: ECSS-E-ST-32-20].

Whilst the backface of sandwich panels with very thin CFRP face sheets can be easily supported, the front face sheet relies on the support offered by the core. Depending on the position, a small machined hole can fall intracell or at the position of a honeycomb cell wall. Larger holes, as needed for inserts, cross several cell walls and intracell spaces, consequently the support provided varies.

Relevant standards provide guidance on machining composites, [See: ECSS-E-ST-32-20 and MIL-HDBK-17].

24.5 References

24.5.1 General

[24-1] MIL-HDBK-17 – Composite Materials Handbook

[24-2] MIL-HDBK 23 – Structural Sandwich Composites

NOTE MIL-HDBK 23 is under review for partial incorporation as Volume 6
MIL-HDBK-17.

24.5.2 ECSS standards

[See: ECSS website: www.ecss.nl]

ECSS-E-ST-32-20 Structural materials handbook

ECSS-Q-70-71 Data for the selection of space materials and processes

25 Potting

25.1 General

The comments apply to the manufacturing process of potting inserts into sandwich panels or structures for space vehicles, [See: 25.2; 25.3; 23.1].

[See also: ECSS-E-30 series; ECSS-Q-ST-70 materials and process-related standards]

25.1.1 Environmental conditions

The environmental conditions for the mixing, potting, and curing of the inserts are stipulated as standard climatic conditions of relevant specifications, e.g. 23/50 of DIN 50014.

Normal laboratory conditions are applicable during manufacturing.

[See also: ECSS-Q-ST-70-22 for limited shelf-life materials]

25.1.2 Face sheet protection

The face sheets of sandwich panels are protected with a temporary layer, e.g. foil; self-adhesive paper.

NOTE Any protective layer should be removed easily and without leaving any residues that are difficult to clean, i.e. cannot cause contamination.

25.1.3 Degreasing of inserts

Before potting, inserts are degreased in a perchlorethylene steam bath. (Identification No. 0001.-LN 9368).

Alternatively, an acetone bath can be used, but frequent changing of the contaminated liquid is necessary.

NOTE 1 The time between degreasing and potting cannot exceed 8 hours.

NOTE 2 After degreasing, inserts are handled with clean lint-free gloves or with the aid of tongs.

25.2 Manufacturing process

The manufacturing process stipulates that the:

- Workpiece, i.e. the sandwich panel (or structure), conforms to the workshop drawing.
- Insert meets the appropriate standards or specifications, [25-1], [25-2], [25-3], [25-4]; [See also: Annex A].
- Potting resin meets the appropriate standards or specifications, [25-9], [25-10]; [See: 25.3].

25.3 Potting compounds

Suitable commercial potting resins, [See: 7.1] tend to be modified with a high content of glass microballoons to produce a light viscous paste. The specific gravity of the resin mixture is typically 0.6 to 0.7.

NOTE The component parts of potting compounds (resin, hardener, accelerators) are classed as limited shelf-life materials and need strict control of their storage, usable life and working conditions, e.g. workshop environment and pot life, [See: 25.1][See also: ECSS-Q-ST-70-22].

25.3.1 Flow characteristics

25.3.1.1 General

The flow characteristics of the potting compound have a strong influence on the success or failure of insert potting. Flow is affected by, [25-13]:

- Resin system viscosity;
- Type, shape, content and distribution of filler material, e.g. glass microballoons;
- Applied pressure;
- Temperature:
 - Mixed resin exothermic reaction;
 - Ambient.

The precise control of individual material-related variables (resin, hardener, filler) has proven to be extremely difficult, e.g. batch variations; dryness, settling and size distribution of filler. Therefore control of the mixed potting compound viscosity just before its use is necessary to aid potting reproducibility.

A typical viscosity range is between 45 Pa.s and 58 Pa.s, [25-13].

NOTE Low viscosity potting compounds (below 3Pa.s) produce severe potting defects, [25-13].

Viscosity is also the parameter which determines usable pot life, which is stipulated as part of process control activities.

25.3.1.2 Processing

Although made of an inert substance, glass microballons are usually dried before incorporation into the resin. This avoids any moisture present affecting the cure or resulting properties.

Potting compounds are processed with the aid of a compressed air cartridge, e.g. 'Semco'.

The injection pressure appears to have no effect on the distribution of the potting compound, although the size and shape of the injection tool needs to be optimised. An injection pressure of 1 bar has proven successful, [25-13].

The mixed resin undergoes an exothermic reaction during cure. This is accelerated by the presence of low thermal conductivity fillers, e.g. glass microballoons. As the ambient temperature also affects viscosity, it too needs control, [25-13].

25.3.2 Resin system: Shur-Lok SLE 3010

This resin system is especially suitable for inserts and is widely used. The resin and hardener components, which are contained separately in the cartridge cases, are mixed according to the instructions supplied and can then be processed in the original cartridge, [25-9].

- Processing time: 20 min. at RT
- Cure cycle time: 24 hrs. at RT
- Storage time: 12 months at RT maximum.
- Optimum characteristics: after 7 days at RT

NOTE This resin does not meet the outgassing limits of 1% TML and 0.1% VCM, [See: ECSS-Q-ST-70-02].

25.3.3 Potting foam: Lekutherm X227+T3

The mixing ratio is:

- Lekutherm X227 resin: 100 parts by weight
- T3 hardener: 30 parts by weight

After mixing, add

- Microballoons B23-500 (3M Corp.): 40 parts by weight

Through mixing results in a soft paste, which does not flow in small quantities, e.g. about 1 cm³ to 2 cm³ adheres to the mixing spatula.

Deviation from the viscosity needed can be corrected by further addition of microballoons or pure resin mixture.

The prepared insert potting foam is then to be placed in a 'Semco' cartridge without cavities. The orifice nozzle diameter is about 2 mm, [[25-10]: KL43022 handling procedure].

- Processing time: 70 min. at RT
- Cure cycle time:
 - 24 hrs at RT: for final machining, [See: 23.5]
 - 48 hrs at RT: for repair, [See: 23.9].
- Storage time: 12 months at RT maximum.
- Adjustment of air pressure: 2.5 bar to 3.5 bar.

NOTE Neukadur EP 270, which is widely used for insert potting, is a more recent variant of the Lekutherm X227 epoxy system. Some variation within properties can therefore be expected between the two resin systems, [See: 7.1].

25.3.4 Other potting materials

When other materials are used for potting, process-related methods and conditions need optimisation and adequate control to ensure good and repeatable insert potting.

[See also: 7.1; ECSS-Q-70-71]

25.4 References

25.4.1 General

- [25-1] 'Inserts for sandwich structures, closed, self-locking with floating and removable nut, screw securing'
ENN 366 (MBB-ERNO)
- [25-2] - Title not stated -
ENN 379 (MBB/ERNO)
- [25-3] 'Inserts for sandwich structures closed, self-locking'
ENN 386 (MBB/ERNO)
- [25-4] 'Inserts for sandwich constructions, closed, with screw locking helical coil insert'
ENN 398 (MBB/ERNO)
- [25-5] 'Bonding tabs'
ENN 34602 (MBB/ERNO)
- [25-6] 'Designation of the surface treatment'
LN 9368 (Beuth-Verlag, Germany)
- [25-7] 'Standard climate conditions '
DIN 50014 (Beuth-Verlag, Germany)
- [25-8] 'Instructions for the issuance of failure messages and failure elimination'.
RL 0008021
- [25-9] SLE 3010: Product data (7-29-70)
- [25-10] Lekutherm X227 + T3: Processing instructions
Bayer GmbH
- [25-11] 'Application of toxic, volatile, non-flammable solvents for cleaning purposes'. UVV 11.2 (VBG 87)
- [25-12] 'Application of adhesive with easily volatile, flammable solvents'. VBG 81
- [25-13] 'Re-evaluation of potting procedure - Final Report',
July 1990. MBB-ERNO (Bremen). ESTEC Contract No.
7830/88/NL/PH(SC)

25.4.2 ECSS standards

[See: ECSS website: www.ecss.nl]

ECSS-E-30 series	Space engineering series
ECSS-E-ST-32-20	Structural materials handbook
ECSS-E-HB-32-21	Adhesive bonding handbook
ECSS-Q-70 series	Space product assurance
ECSS-Q-ST-70	Materials, mechanical parts and processes
ECSS-Q-ST-70-02	Thermal vacuum outgassing test for the screening of space materials
ECSS-Q-ST-70-22	Control of limited shelf-life materials
ECSS-Q-70-71	Data for the selection of space materials and processes

26

Incoming inspection

26.1 Tests

26.1.1 Material specifications

Material incoming inspection tests are performed in accordance with the relevant material specification. These tests guarantee the minimum values that have a 99% probability of being exceeded.

26.1.2 Additional tests

Additional tests are necessary to guarantee or predict the insert strength with more reliability. These tests relate to the:

- Honeycomb core, [See: 26.2].
- Potting Resin, [See: 26.3].
- Composite face sheets, [26-1], [See: 26.4].

26.2 Honeycomb core

26.2.1 Core properties

Incoming inspection test methods for honeycomb cores determine the actual core properties, [26-2]. These cover:

- Density;
- Compressive strength⁽¹⁾;
- Shear strength;
- Foil thickness.

NOTE (1) Within the IATP insert allowable test programme, a minimum 'stabilised strength' was stipulated, [See: Annex E].

26.2.2 Insert strength

The relationship of insert strength to actual core strength is considered for two levels, [See: 12.3]:

- Average;
- Minimum.

[See also: Figure 6-4 for deviation of actual core strength from guaranteed values

NOTE The guaranteed values are low.

26.3 Potting resin

Insert potting resins are usually epoxy-based products, [See also: 7.1; 25.2]. Variations between batches of material are not uncommon.

Storage conditions can affect the final properties of cured resins, [See: 23.10; ECSS-Q-ST-70-22].

Incoming inspection is important for:

- Potting compounds for standard-types of inserts;
- Resins used for bonding non-standard inserts, where potting is replaced by an equivalent bonding process, [See: A.3; F.6].

NOTE It is increasingly common for all the constituent parts of resin-type materials to be subjected to quality assurance procedures, including fillers. This can also extend to consumables used in the processing.

26.3.1 Strength

26.3.1.1 General

Testing is necessary when a guaranteed value of potting resin strength is needed for, e.g.:

- Core densities exceeding 50 kg/m³
- Large core height with partial potting.

26.3.1.2 Test methods

Suitable test methods are given in Table 26-1 for determining:

- Bending;
- Tensile.

These can be applied as alternatives.

Table 26-1: Incoming inspection: Potting resin strength tests

Test method	Test standard	Sample dimensions (mm)	Acceptance strength ⁽¹⁾ (N/mm ²)
Bending	DIN 53452	3 × 15 × 80	110
Tensile	DIN 53455	3 × 20 × 150	60

(1) Proposed acceptance values apply to pure resins without filler additives, e.g. microballoons.

NOTE The IATP insert allowable test programme stipulated a compression test to ASTM D 695M to provide an 'average value' for potting compounds, [26-1], [See also: Annex E].

26.3.2 Hardness

A hardness test on each batch of mixed resin and hardener provides a cure check on the potting compound. This can form part of the manufacturing process control, [26-1].

[See also: 27.1]

26.4 Composite face sheets

Inspection and test procedures applied to composite face sheet materials can be grouped as, [See also: ECSS-E-ST-32-20, ASTM website]:

- Characteristics of the basic material, e.g. often as prepreg;
- Properties of the cured composite laminate.

NOTE Acceptable defect levels form part of the incoming inspection of composite materials.

26.4.1 Material characteristics

The requirements stated in materials specifications are checked. These are normally an 'average value' with a tolerance, e.g. fibre content 60% ± 2%.

Tests are conducted to recognised standards, e.g. ASTM or equivalents, and can include, [26-1]:

- Fibre content (%);
- Resin content (%);
- Areal weight, i.e. mass per unit area for:
 - prepreg.
 - dry fabric or cloth.
- Volatile content (%).

26.4.2 Composite laminate properties

The requirements for 'minimum' and 'average' values are checked. These include, [26-1]:

- Interlaminar shear strength, ILSS;

- 4-point flexural test, to provide values of:
 - Strength;
 - Stiffness.

These tests are conducted in accordance to recognised standards, e.g. ASTM or equivalents.

NOTE Test samples replicate exactly the sandwich face sheet, e.g. materials, lay-up, number of plies, cure cycle.

26.4.3 Consumables

It is increasingly common for consumables used in composite processing, e.g. release plies, peel plies and cleaning agents, to be subjected to incoming inspection procedures. This is especially true where structural adhesive bonding is used as an assembly process, e.g. bonding CFRP face sheets onto cores to produce sandwich panels, [See also: ECSS-E-HB-32-21].

26.5 References

26.5.1 General

- [26-1] 'Insert Allowable Test Programme - IATP 2'
Kongsberg Gruppen Report No. 02TR68040906 (October 1997).
- [26-2] MIL-C-7438
Core material - aluminum, for sandwich construction

26.5.2 ECSS standards

- [See: ECSS website: www.ecss.nl]
- ECSS-Q-ST-70-22 Control of limited shelf-life materials
- ECSS-E-ST-32-20 Structural materials handbook
- ECSS-E-HB-32-21 Adhesive bonding handbook

27

Manufacture control

27.1 Testing

27.1.1 General

The tests conducted as part of manufacture control are grouped as:

- Mechanical, [See: 27.3];
- Non-destructive, [See: 27.4].

[See also: Clause 29 for test methods for determining permissible loads and design allowables]

27.1.2 Mechanical

Destructive mechanical tests are conducted on reference samples, [See: 23.6].

[See: 27.3]

27.1.3 Non-destructive

Non-destructive testing (or inspection) is carried out on:

- Samples, and
- Manufactured flight article.

[See: 27.4]

27.1.4 Development tests

27.1.4.1 General

Tests to determine insert strength values (not covered by this handbook) can be necessary, e.g.:

- Special types of core;
- Non-standard inserts, [See also: Annex F for case studies];
- Novel insert arrangements.

Basic test programme information is given in [27-1], [27-2].

[See also: Clause 29]

27.1.4.2 Potting process

The factors tested and inspected in the development of a potting process, [27-3], include:

- Bore hole, e.g. drilling, dimensions, adjacent cell walls;
- Core, e.g. perforation;
- Potting compound, e.g. viscosity, temperature.

Other factors which can have an influence are:

- Features at the bottom of the bore hole, e.g. 'corner' at core-to-bottom face sheet, which can affect flow of potting compound;
- Injection pressure profile on flow of potting compound;
- Injection nozzle shape and size.

27.2 Reference samples

The purpose of testing reference samples is to confirm that the potting process used on flight articles meets those stipulated in the design.

[See also: 23.6 for reference sample manufacture; 27.3 for mechanical testing Acceptance loads

The acceptance values are defined in the design documentation.

Unless stated otherwise in the documentation, the criteria applied are:

- Pass: Strength values 80% or greater of $P_{SS\ ave}$.
- Reject: Strength values less than 80% of $P_{SS\ ave}$.

27.3 Mechanical testing

Mechanical tests used to evaluate insert capability are, [27-4], [27-5]:

- Tensile Pull-Out:
 - single insert.
 - groups of inserts.
- Shear;
- Bending;
- Torsion.

Destructive tests are applied to reference samples. The post-test samples are then sectioned to evaluate the quality of the potting.

Mechanical tests are also used on qualification and flight structures, but to lower (non-destructive) load levels, [27-4].

[See also: Clause 29 for test methods used to determine design allowables; Annex F for case studies including test methods used in some European projects]

27.3.1 Tensile pull-out test

27.3.1.1 Sample

Reference samples are manufactured at the same time as the flight structure from exactly the same materials, [See: 23.6; Figure 23-4].

NOTE The sandwich sample height, H in Figure 23-4 is the same as that of the flight structure. **Test fixture**

Figure 27-1 shows a simple test fixture for out-of-plane tensile loading tests on sandwich specimens of 80 mm × 80 mm size with a centrally located insert. A version for compression or fatigue out-of-plane testing is shown in Figure 27-2 for two different sandwich thicknesses, [27-5].

When load is acting on the insert, the sandwich plate is pressed against one (for pure tension) or two (for tension and compression) aluminium plates which both have a central hole, 70 mm in diameter, to ensure a sufficient free area around the insert.

The test fixture is suitable for sandwich thicknesses, $(c + 2f)$ of up to 60 mm and for insert diameters, d_i up to 22 mm. It can be used in either static or dynamic (servo-hydraulic) test machines.

[See also: H.1 for the engineering drawings of the test fixture. A photo is shown in Figure F-12]

Note that for insert/sandwich configurations with higher load-bearing capability, a size of 80 mm × 80 mm for the samples and the corresponding cover plates of the test fixture can be too small. Under high out-of-plane forces the remaining small support area of the cover plate outside the central hole of 70 mm diameter can then lead to such stress concentrations that strong crushing of the honeycomb core is observed [27-5]. In this case, an enlargement of the dimensions to 100 mm × 100 mm or even more is necessary.

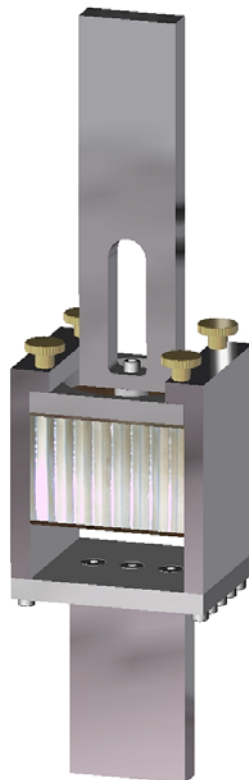

Figure 27-1: Manufacture control: Out-of-plane test fixture for tension (pull-out) tests

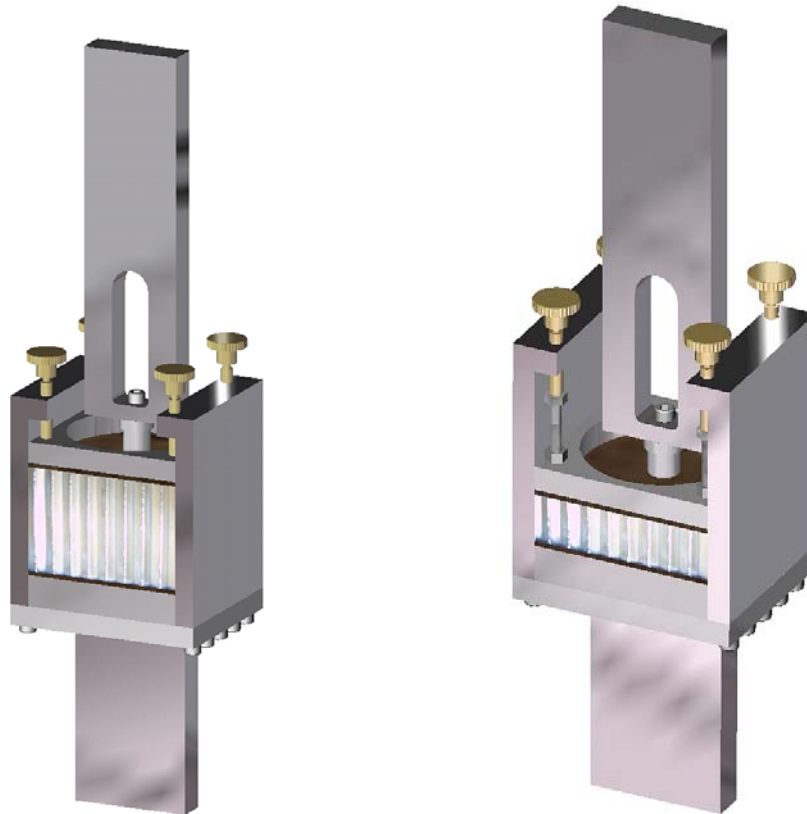

Figure 27-2: Manufacture control: Out-of-plane test fixture for compression or fatigue tests

27.3.1.3 Test

The test is performed in an electronically-controlled tensile testing machine that can record the load-deflection. A suitable loading rate is 1 mm/min. Loading is stopped after the maximum load has been reached, i.e. at about 2 mm constant deflection of the face sheet. This makes it easier to judge fracture conditions after samples have been taken, [27-5].

27.3.1.4 Evaluation: Pass and reject criteria

If the stated 'pass' value is attained then the acceptance conditions are met, [See: 27.2 – acceptance loads].

27.3.1.5 Sample examination

A sample of potting is removed from the tested sample to evaluate the quality of the potting. This enables a steady improvement in potting technology. It is important to investigate any correlation between potting failures and bore hole drilling, [See: Figure 28-1].

27.3.2 Shear test

Figure 27-3 shows the front and rear view of a test fixture for in-plane loading (shear) tests on inserts, [27-5].

In static tests, the bar acting on the insert screw is simply pulled out of the U-shaped groove in the base plate. The sandwich is then pressed against a cross-bar on the inner side of the base plate.

In dynamic (fatigue) tests the force is applied in both directions. Therefore there is a second cross-bar on the top side of the base plate. In order to avoid slipping of the sandwich specimen, the exact position of this second (upper) cross-bar can be adjusted by means of eccentric screws according to the actual specimen size.

The test fixture is suitable for sandwich specimens of 80 mm × 80 mm; as shown. The maximum sandwich thickness, $(c+2f)$ depends only on the screw length between the two plates. The insert diameter, d_i can be ≤ 20 mm for flush-mounted inserts, but slight modifications of the loading bar can be necessary for larger or protruding inserts.

[See also: H.3 for the engineering drawings of the test fixture. A photo is shown in Figure F-12]

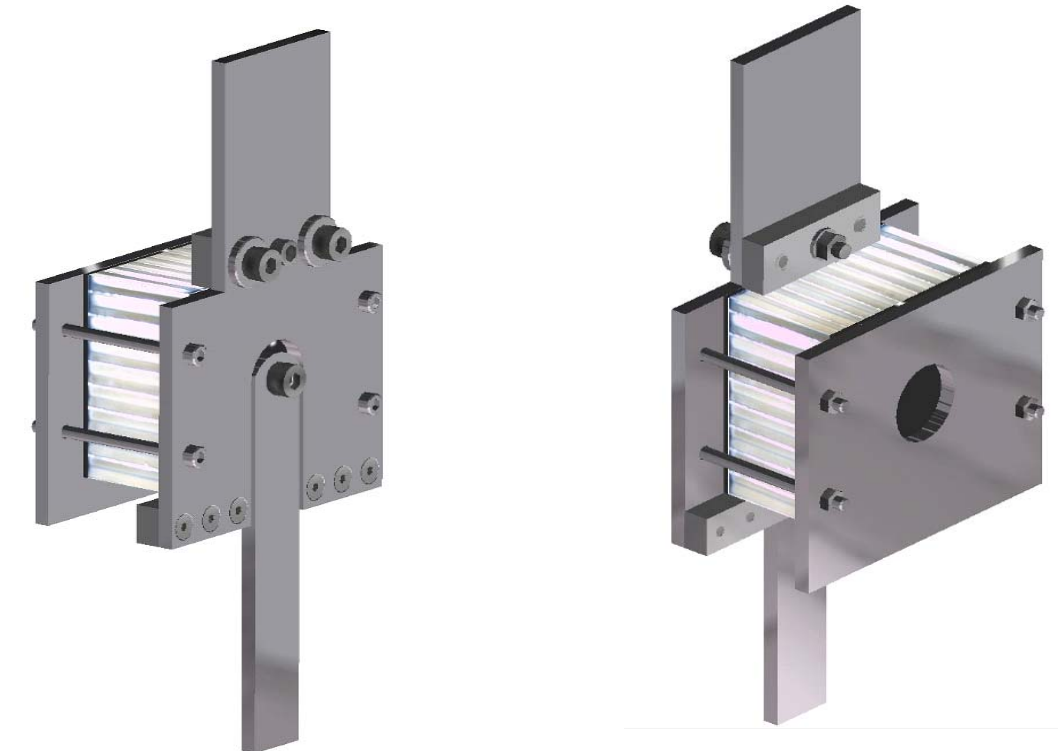

Figure 27-3: Manufacture control: In-plane test fixture for shear Bending test

Figure 27-4 shows a test fixture for static bending tests on inserts. The sandwich specimen of 80 mm × 80 mm size with a thickness of up to 60 mm is fastened in a cage of aluminium plates, which is mounted on a back side structure attached to the test machine. There is a free area of 70 mm in diameter around the insert, [27-5].

The bending moment is applied by means of a rigid cantilever beam, linking to the crosshead of the test machine. The distance at which the crosshead links to the cantilever beam is adjustable. The thread connection and the contact area between the beam and the insert are precisely aligned.

[See also: H.4 for the engineering drawings of the test fixture. A photo is shown in Figure F-12]

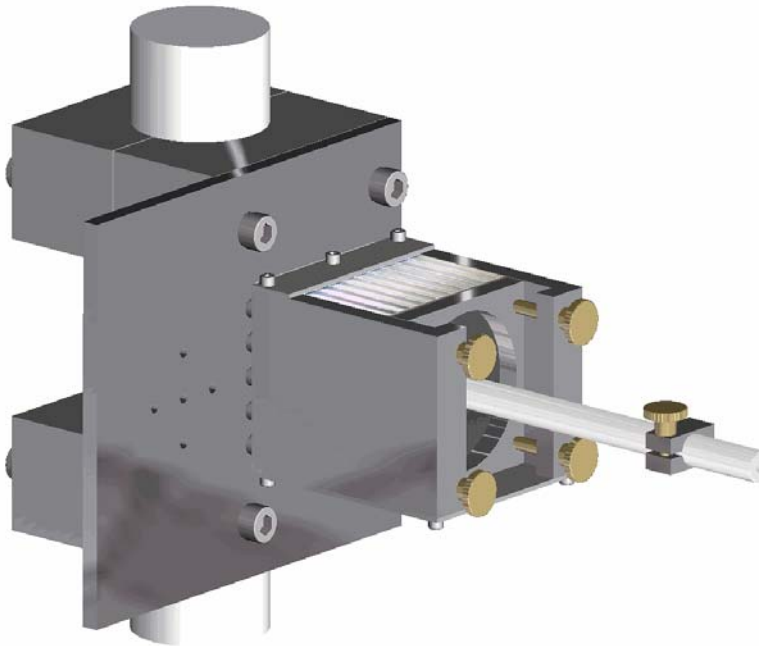

Figure 27-4: Manufacture control: Bending test fixture

27.3.3 Torsion test

Figure 27-5 shows a configuration for torsion tests on inserts. The fixture of the sandwich specimen (on the left-hand side) is identical to that for bending tests, [27-5].

On the right-hand side there is a wheel from which a steel ribbon is spooled off when the crosshead of the test machine pulls on the end piece. Thus a defined torque can be applied. The rotating axis has an end piece with half-inch square section so that a standard socket from an ordinary toolbox can be attached. This socket, and the corresponding insert screw, can be selected according to insert type, e.g. size, thread.

[See also: H.5 for the engineering drawings of the test fixture. A photo is shown in Figure F-12]

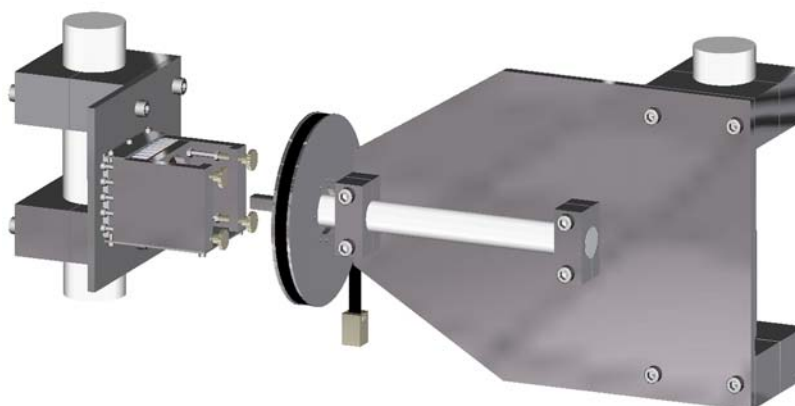

Figure 27-5: Manufacture control: Torsion test fixture

27.4 Non-destructive testing

27.4.1 Radiography

The actual condition of potting mass after manufacturing can only be judged by an X-ray view parallel to the axis of an insert. However, this only provides a 2-dimensional view of the potting.

The features to be examined are:

- Number of filled cells;
- Number of connected cell walls;
- Estimation of potting height: by comparing the X-ray with potted inserts of known potting height;
- Large air inclusions in the potting mass.

NOTE Knowing the number of connected cell walls is particularly important to:

- reduce variability of strength values, or
- calculate the actual load-carrying capability of an insert.

[See: 7.3]

27.5 Composite face sheets

Composite face sheets are essentially thin laminates. The manufacture control procedures applied to laminates are therefore appropriate to face sheets on sandwich panels.

In addition to incoming inspection and checks made during the lay-up, e.g. number of plies and their orientation, post-manufacture control measures include:

- Inspection for delamination, flaws and defects;
- Testing (on reference or witness samples) to confirm mechanical properties.

After the face sheets are bonded to the core, the sandwich panel is then subjected to further inspection, e.g.

- Debonds between the core and face sheet;
- Deformation or damage to the face sheets;
- Deformation or damage to the core.

[See also: ECSS-E-ST-32-20; ECSS-E-HB-32-21]

27.6 References

27.6.1 General

- [27-1] 'Standardization of Design Analysis and Testing of in Structural Sandwich Elements', Final report. ESTEC Contract No. 3442/77/NL/PP.
- [27-2] 'Standardisation of Design Analysis and Testing of Inserts in Structural Elements', Final report. ESTEC Contract No. 3442/77/NL/PP - Rider 1.
- [27-3] 'Reevaluation of Potting Procedure - Final Report',
July 1990. MBB-ERNO (Bremen). ESTEC Contract No.
7830/88/NL/PH(SC)
- [27-4] 'MMS Contribution to ESA Insert Design Handbook' Matra Marconi
Space Report No. NT/102/BG/355013.96 (December 1996).
- [27-5] J. Block, R. Schütze, T. Brander, K. Marjoniemi, L. Syvänen, M. Lambert:
DLR Braunschweig/Helsinki Univ. Technology/ Patria/ESTEC
'Study on Carbon Fibre Tube Inserts',
ESTEC Contract No. 16822/02/NL/PA (2004)

27.6.2 ECSS standards

[See: ECSS website: www.ecss.nl]

ECSS-Q-70-series	Space product assurance
ECSS-E-30-series	Space engineering
ECSS-E-HB-32-20	Structural materials handbook
ECSS-E-HB-32-21	Adhesive bonding handbook

28

Quality control

28.1 General

Quality control activities conducted at various stages of design, manufacturing and testing form part of the overall quality assurance plan associated with the project. The precise details are given in appropriate standards and specifications, [See: ECSS website: www.ecss.nl].

28.1.1 Materials and processes

28.1.1.1 Overview

All standard activities related to quality control of materials and processes are applied to sandwich panels and their component parts, including but not limited to, [See: ECSS-Q-ST-70; ECSS-Q-70-71]:

- Materials,
 - core;
 - face sheet;
 - adhesive;
 - coatings.
- Components:
 - inserts;
 - fasteners.
- Processes:
 - machining, [See: 28.2];
 - potting, [See: 28.3].

28.1.1.2 Potting

Control of the potting process is particularly important because it is a chemical process that is sensitive to inaccuracies that can result in failures, [See also: 23.10 for defects].

NOTE Permissible values cited within this handbook are based on a correctly performed potting process without significant failures.

28.1.2 Documentation and traceability

All aspects of materials and processes control meet the applicable ECSS standards or other approved specifications cited within the design documentation. Notification and control of non-conformances are also governed by the appropriate standards, [See: ECSS-Q-ST-70].

28.1.3 Personnel

All aspects relating to personnel using materials, processes and their control are applied and documented in accordance with the governing standards.

28.1.4 Health and safety

Safety procedures and practices conform to the appropriate occupational health and safety standards.

Safety equipment is maintained, is made available and used by personnel during the various manufacturing stages.

Any particular requirements stated in 'safety notices' supplied with materials are included in the overall safety plan, e.g. resins and hardener systems that can cause skin irritation and respiratory problems; skin protection during the use of oxidising chemicals; dust removal.

28.2 Control of bore hole

28.2.1 Inspection criteria

All bore holes are visually inspected prior to insert potting. The inspection criteria include:

- Diameter of a bore hole in the face sheet is within a tolerance of 0 to +0.03 mm of the nominal insert diameter;
- Bore holes are a constant diameter over their machined depth, i.e. parallel sides and definitely not conical, [28-1];
- Bore holes are normal to the panel, i.e. to avoid unacceptable bending loads, [See: Figure 15-1];
- Depth of bores in the honeycomb-sandwich structure exceed the overall height of the insert by 5 mm, [28-1];
- The bottom of the machined bore hole is flat, i.e. without bent or dislocated cell foils that can otherwise:
 - Impede flow of potting compound;
 - Positioning of insert (normal to the panel and at the correct depth).
- To enable free flow of potting compound into open cells, the area surrounding the bore in the honeycomb core are:
 - free From defects;
 - Without any bent cell walls, [28-1];
 - Dislocated layers of core foil.
- To enable free flow of potting compound under the insert, the core cells beneath the insert are open, i.e.:

- Free from any bent cell walls, [28-1];
- Dislocated layers of core foil.
- Undercutting or detachment of the core from the face sheet caused by mechanical damage or overheating cannot exceed the radius by more than 2 mm.
- Radius of core bore hole is never less than the nominal dimensions of the insert flanges. This leads to a strength reduction below the minimum permissible values, [See: 28.3; Figure 28-1, part 4].

NOTE 1 This can occur if a blunt or damaged punching tube is used or the bore hole drilling and reaming process is insufficient.

NOTE 2 To avoid contamination, lubricants or cooling fluid cannot be used.

28.3 Control of potting

The potting process should avoid the types of failures shown in Figure 28-1 and listed in Table 28-1.

The methods applied for failure detection are:

- Step-by-step process control;
- Strength test on reference samples, [See: 23.6; 27.3];
- Proof loading (100% or less) all inserts, [See: 23.7].

None of these methods alone guarantees detection of all failures, [See: Table 28-1

Consequently, a combination of control methods is strongly advised.

NOTE Process control is very important because it detects most failure types.

[See also: 25.1; 25.2; 25.3 for potting process]

1		<p>Incomplete filling</p>	<p>Too short duration of injection Unperforated core, too high viscosity</p>
2		<p>Air inclusion underneath insert bore holes</p>	<p>Too low viscosity of potting mass</p>
3		<p>Incomplete filling</p>	<p>Distance between insert bottom and core is less than 3 mm, or cell walls are dislocated</p>
4		<p>Potting radius smaller than insert radius $b_p < b_i$</p>	<p>A damaged or blunt punching tube makes a core bore hole smaller than the nominal insert diameter.</p>

Figure 28-1: QA: Poor potting causing strength degradation Table 28-1: QA: Potting failure and detectability

Item	Reason		Effect				Detectable by		
			Strength loss	Total loss ⁽¹⁾	Dynamic load loss	Outgassing	Process control	Reference sample	100% Load control
Resin, hardener, filler <small>(5), (6)</small>	1	mixing ratio	✓			✓	✓	✓	✗
	2	poor mixing	✓			✓	✓	✓	
	3	wrong component	✓	✓	✓	✓	✓	✓	✓
	4	storage ⁽²⁾	✓			✓	✓	✓	✗
Adhesion	5	poor cleaning	✓		✓		○	○	○
	6	contamination ⁽⁴⁾	✓		✓		○	○	○
Process	7	bore hole failure	✓				✓	✗	✗
	8	poor filling ^{(5), (6)}	✓	✓	✓		○ ⁽³⁾	✗	○
	9	air bubbles (small)	✓				✓	✗	○
	10	humidity	✓		✓		✓	✗	✗

KEY: ✓ - Yes; ✗ - No; ○ - Possible.

- (1) Tear-out at low load.
- (2) Incorrect storage or shelf-life expired.
- (3) Inspection of bore holes after filling.
- (4) Post-cleaning.
- (5) Viscosity control of mixed potting compound necessary, [28-1].
- (6) Temperature control of mixed potting compound and working environment necessary, [28-1].

28.4 Core incoming inspection

28.4.1 Minimum core strength values

The minimum core shear strength τ_{Wmin} and τ_{cmin} can be unacceptably low because of:

- Minimum foil thickness, i.e. density less than ρ_N ;
- Very high degree of expansion;
- Very low material strength of foils;
- Extensive distortion and buckling.

This can appear very conservative, as there is a tendency for:

- Density to be even higher than nominal;
- Under-expansion due to constraints from the outer border during panel manufacturing.

28.4.2 Inspection sequence

An inspection sequence, shown in Figure 28-2, is successful by:

- Simplifying incoming inspection, and
- Enabling a simple insert selection without extensive analysis.

NOTE Compliance with the standard means that minimum core strength values can be applied.

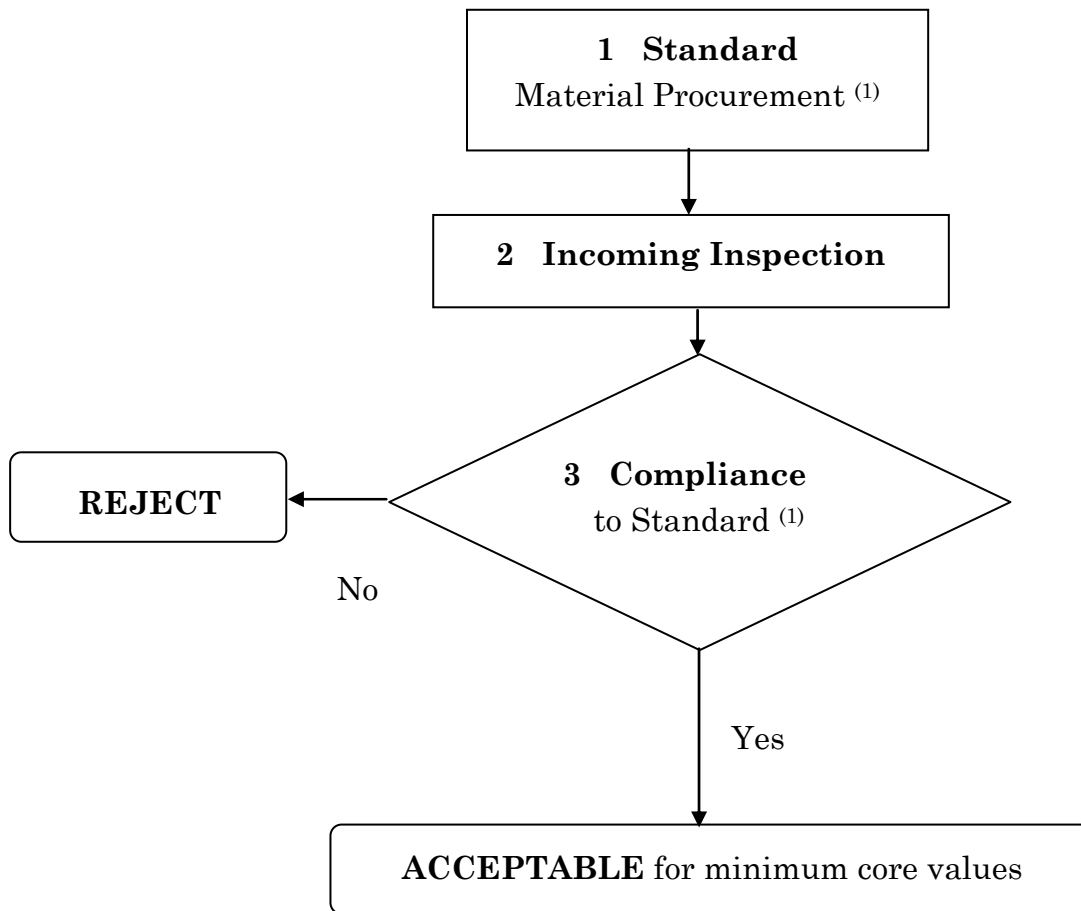

(1) Standard MIL-C-7438

Figure 28-2: QA: Honeycomb core - incoming inspection

28.4.3 Perforated cores

Perforations in cores have a profound effect on potting compound flow, hence the success of the potting process, [28-1].

Conformance of cores to material specifications includes checking for the presence of perforations by a visual inspection, [28-1].

28.5 Core normalised density

28.5.1 Procedure

To determine the density under nominal degree of expansion, the procedure used is:

- Cut test pieces from core material (MIL-C-7438);
- Weigh samples;
- Calculate actual density;

- Determination of actual cell size by counting 10 cells and measuring their overall length in *W*-direction;
- Calculate of actual degree of expansion, in %, by:

$$\frac{\text{actual cell size}}{\text{nominal cell size}} \times 100 [\%] \quad [28.5-1]$$

- Determine the correction factor, K_{ex} ; an example curve is shown in Figure 28-3;
- Correct actual density, ρ to obtain normalised density, ρ_N :

$$\rho_N = K_{ex} \rho_{act} \quad [28.5-2]$$

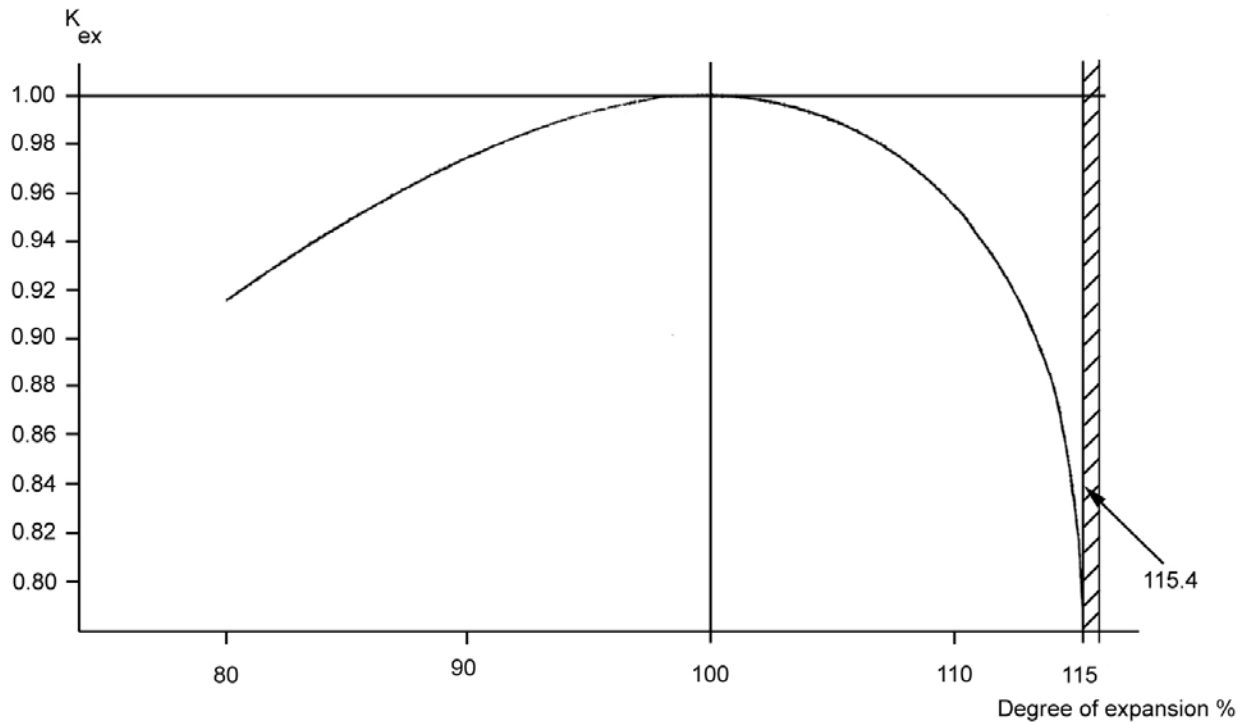

Figure 28-3: QA: Core density correction factor for degree of expansion

28.6 References

28.6.1 General

- [28-1] 'Reevaluation of Potting Procedure - Final Report',
 July 1990. MBB-ERNO (Bremen).
 ESTEC Contract No. 7830/88/NL/PH(SC)
- [28-2] MIL-C-7438

28.6.2 ECSS standards

[See: ECSS website: www.ecss.nl]

ECSS-Q-70-series Space product assurance

ECSS-Q-ST-70 Materials, mechanical parts and processes

ECSS-Q-70-71 Data for the selection of space materials and processes

ECSS-E-30-series Space engineering

ECSS-E-HB-32-20 Structural materials handbook

ECSS-E-HB-32-21 Adhesive bonding handbook

29 Testing

29.1 General

The Test procedures and techniques for determining permissible loads and design features are described. These cover:

- Insert static strength, [See: 29.2]:
 - Out-of-plane;
 - In-plane;
 - Bending;
 - Torsion.
- Geometric effects on insert static strength, [See: 29.3]:
 - Edge distance;
 - Insert proximity.
- Insert dynamic tests, [See: 29.4]:
 - Sinusoidal loading;
 - Static residual strength.

[See also: 27.1; 27.3; Annex H for other mechanical tests and associated test jigs used in manufacture control]

29.2 Insert static strength tests

29.2.1 Out-of-plane tests

The purpose of the test is to measure the ultimate out-of-plane insert load, i.e. tension or compression. The deflection is also measured and the deflection behaviour recorded as a curve. The general test arrangement is shown schematically in Figure 29-1. A real test fixture of this type is depicted in Figure 27-1 and Figure 27-2, [See also: Photo: Figure F-12, Technical drawings: H.2].

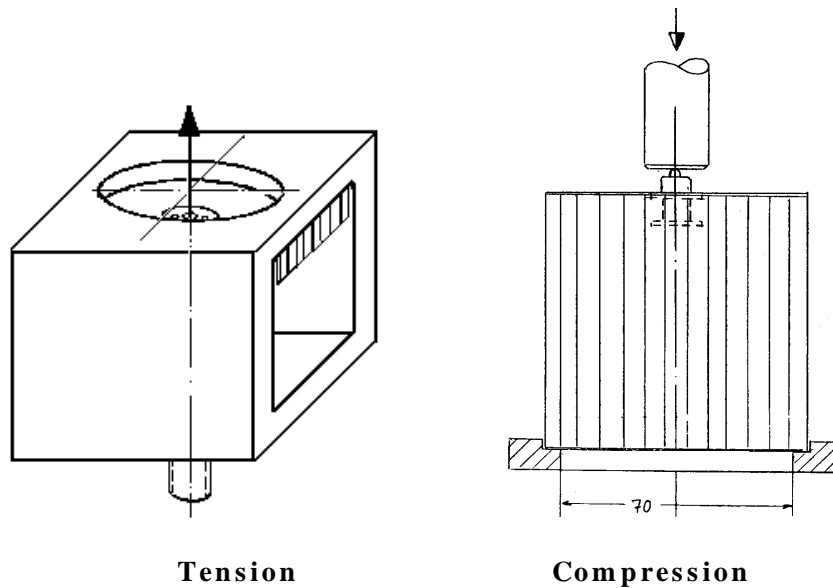

Figure 29-1: Testing: Insert static out-of-plane strength fixture

The test sample size is at least 80 mm × 80 mm, [29-1] stipulates 100 mm × 100 mm. Larger dimensions are necessary for insert/sandwich configurations with high load-bearing capability to ensure a sufficient support area around the central hole of 70 mm. Otherwise, at higher out-of-plane forces, honeycomb core crushing can occur.

The test is performed in a tensile testing machine, which enables the recording of load-displacement values.

A loading rate of 2 mm/min was chosen because a deflection of 2 mm includes the ultimate load for all sandwich conditions. One minute is a typical loading time and failures usually occur after about a minute.

Loading is stopped after the maximum load has been reached, when the deflection of the face-sheet is about 2 mm. This makes it easier to judge fracture conditions when samples are subsequently examined.

NOTE The test conditions stated are also valid for specimens that are pre-treated by dynamic or thermal loading.

A typical force-displacement curve has a linear region at first, then a non-linear region before the maximum load. The end of the linear region is measured from the curves and the value is known as the 'first peak value'.

29.2.2 In-plane tests

The purpose of the test is to measure the ultimate in-plane load of the insert. It is also possible to measure the ultimate load in other directions, e.g. 30° and 60°. The general test arrangement is shown schematically in Figure 29-2.

A real test fixture of this type, but only for 0° orientation, is depicted in Figure 27-3,

[See also: Photo: Figure F-12, Technical drawings: H.3].

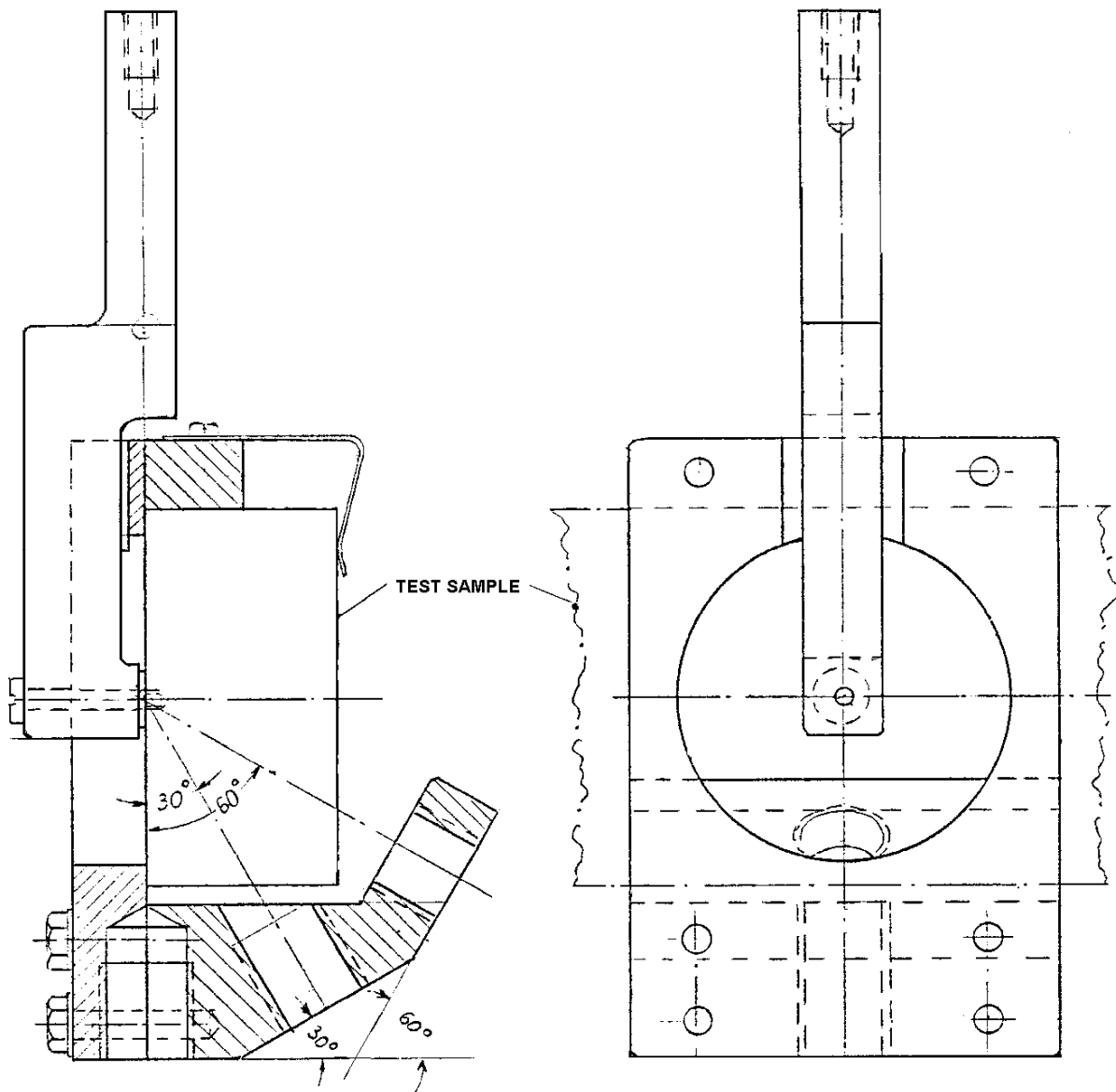

Figure 29-2: Testing: Insert static in-plane strength fixture

The test is performed in a tensile testing machine, which enables the recording of a load-displacement curve.

The loading rate is 2 mm/min.

29.2.2.1 ASTM method

Another in-plane test method is also used; ASTM F606-95b, [29-2]. This test fixture is shown in Figure 29-3.

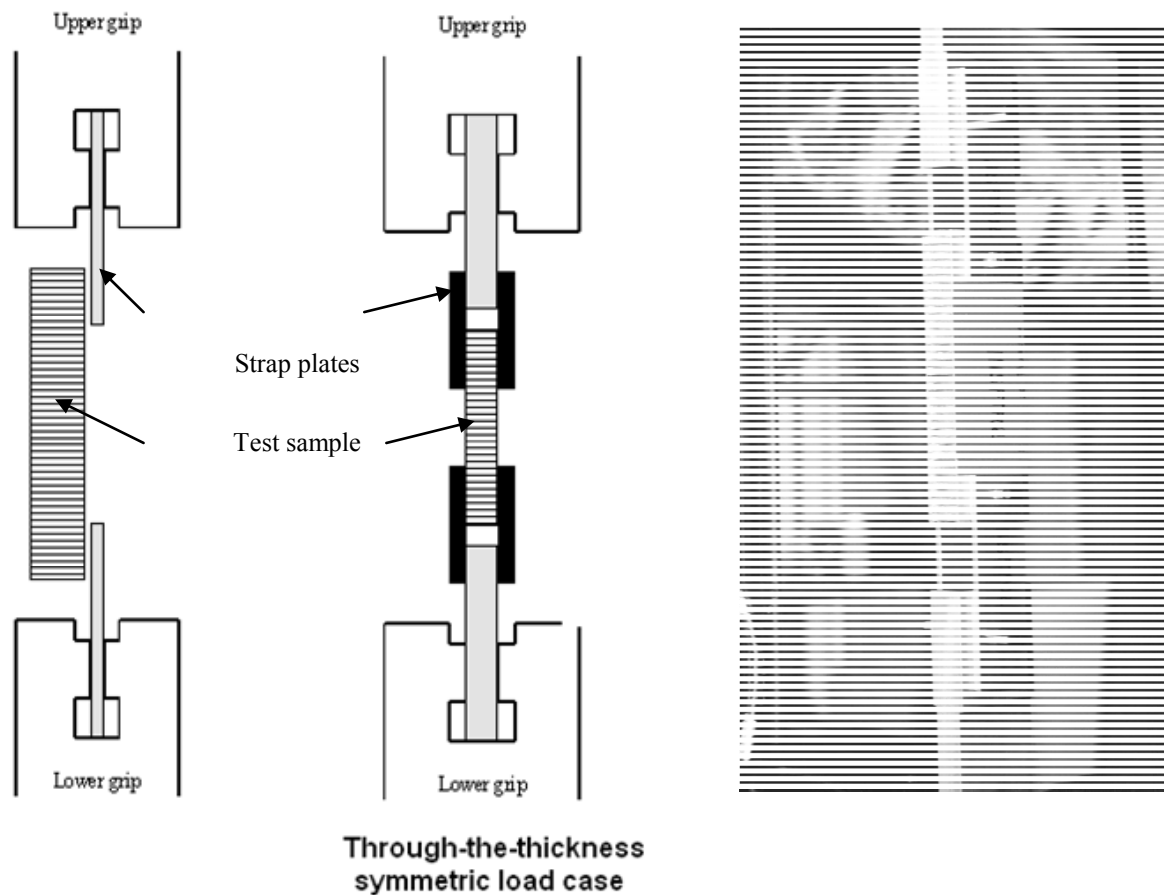

Figure 29-3: Testing: ASTM insert static in-plane strength fixture

The dimensions of the specimens are 180 mm × 60 mm. The strap plates are 130 mm × 40 mm × 5 mm for a through-the-thickness specimen in the symmetric load case. For other cases, the dimensions of the strap plates are 200 mm × 40 mm × 5 mm.

The test is performed in a series of sequential steps:

1. The temperature and humidity measurement system of the test room is activated. The measured temperature and humidity values are stored in a computer. The test is performed at room temperature.
2. Strap plates are clamped first to the lower grip and then to the upper grip of the testing machine. Through-the-thickness tests need special fixtures. One of the two through-the-thickness testing fixtures, connected to the specimens with the shear pin, is clamped to the upper grip of the testing machine. The other testing fixture is clamped to the lower grip of the testing machine. The lower grip is then raised to enable the connection between the strap plate and the lower testing fixture by means of another shear pin.
3. A visual inspection is performed to verify the alignment of the specimen with the testing machine.

4. The load is applied at a rate of 2 mm/min; stroke control is used.
5. At the beginning of the test, slippage occurs between the insert flange and the strap plates. Slippage is considered to occur when a constant or decreasing value of the load is registered while the stroke is still increasing. The load at which slippage occurs is noted.
6. A failure of the specimen is considered to occur when a load drop equal to 20% of the maximum load is registered. The failure load is recorded, i.e. the peak value.
7. The failure mode is determined and the specimen photographed from both sides.

29.2.3 Bending tests

The purpose of the test is to measure the ultimate bending load capability of an insert, to measure bending deflection and to examine the behaviour using a load deflection curve.

The loading rate is 2 mm/min. The general test arrangement is shown schematically in Figure 29-4.

A real test fixture of this type is depicted in Figure 27-4, [See also: Photo: Figure F-12, Technical drawings: H.4].

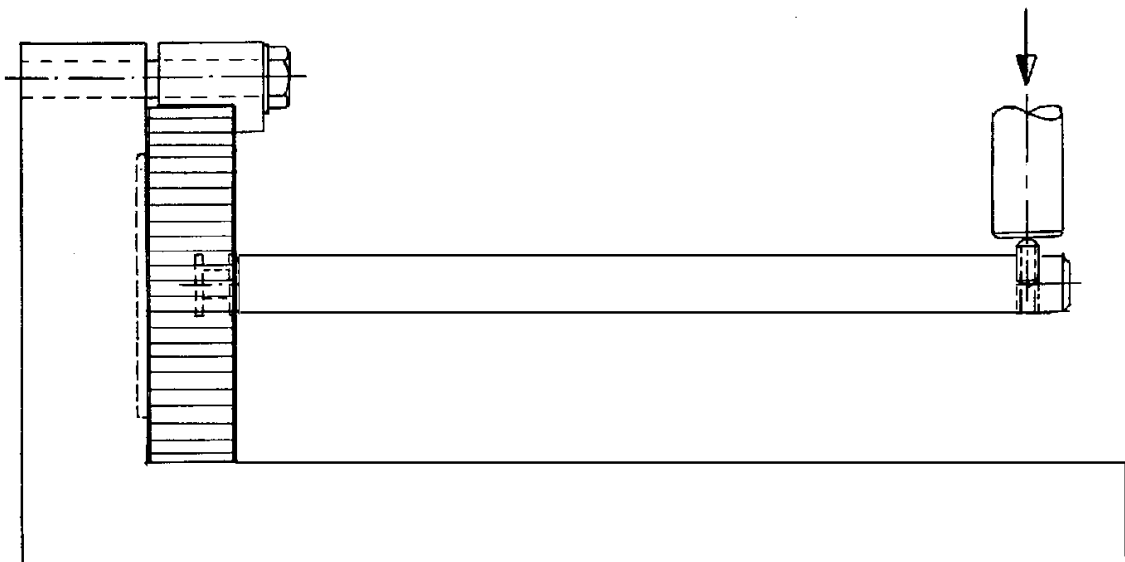

Figure 29-4: Testing: Bending fixture

29.2.4 Torsion tests

The purpose of the test is to measure the ultimate torsion load of one insert. The test is performed in a torsion testing machine.

A suitable torsion test device is depicted in Figure 27-5, [See also: Photo: Figure F-12, Technical drawings: H.5].

29.3 Geometric effects: Insert static strength tests

The position of inserts from the edge of a sandwich panel (edge distance), the distances between inserts (proximity) and the loading directions on adjacent inserts can all affect insert capability.

[See: Clause 18 for edge influence; Clause 19 for insert groups]

29.3.1 Edge distance

The purpose of the test is to measure the ultimate out-of-plane and in-plane load capability of the insert, which is dependent on the various distances to the edge of the sandwich plate.

The test is performed in a tension test machine, which enables the recording of a load-displacement curve. The test fixture and set-up are shown in Figure 29-5.

The loading rate is 2 mm/min.

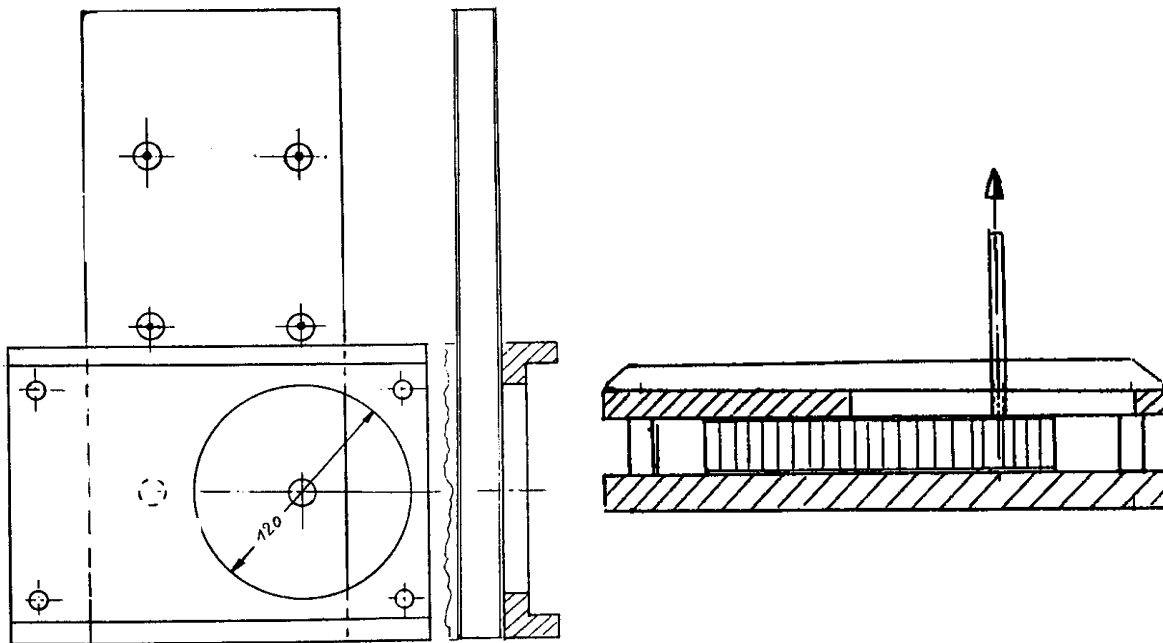

Figure 29-5: Testing: Edge distance fixture

29.3.2 Insert proximity

The distance between adjacent inserts, i.e. their proximity, and the loading directions (same or opposite) can affect insert capability.

The purpose of the test is to measure the ultimate out-of-plane tension (same) and the tension-compression (opposite) loads, which are dependent on the various distances between inserts.

The test is performed in a tensile testing machine, which enables the recording of a load-displacement value. The loading rate is 2mm/min.

Figure 29-6 shows the test fixture and set-up for tensile loading in the same direction; the load is the same on both inserts.

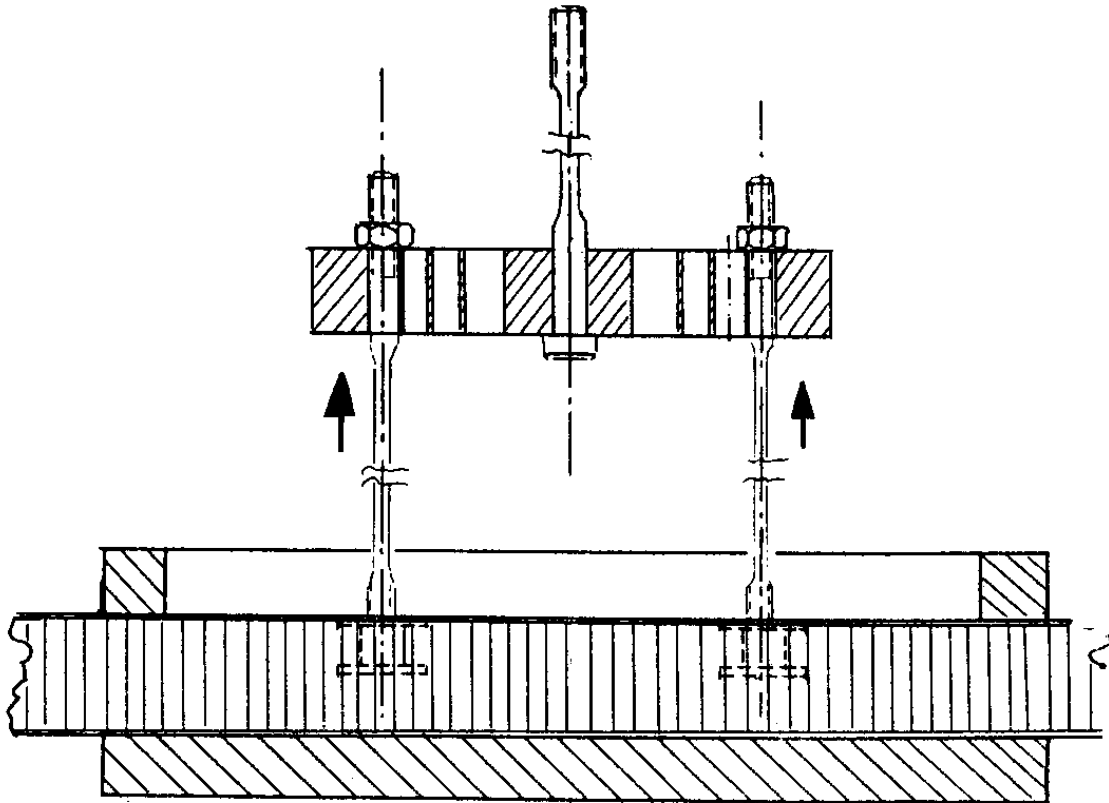

Figure 29-6: Testing: Insert proximity tensile fixture

The tension-compression proximity testing fixture for inserts, i.e. loaded in opposite directions, is shown in Figure 29-7.

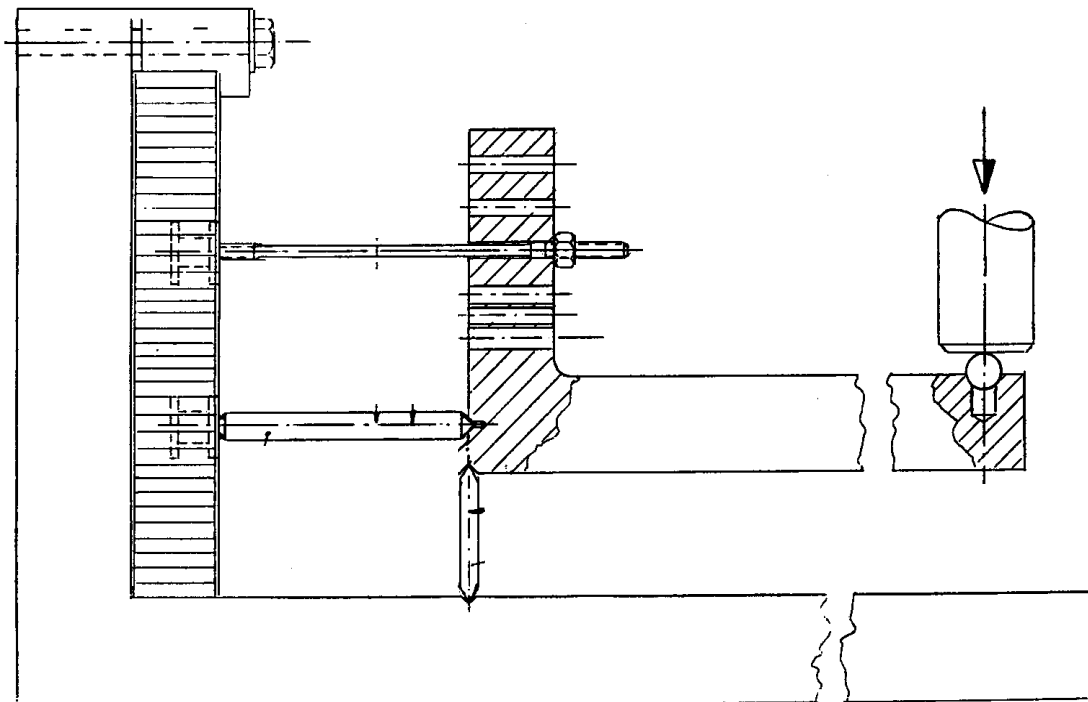

Figure 29-7: Testing: Insert proximity tensile-compression fixture

29.4 Dynamic tests

29.4.1 Sinusoidal loads

The purpose of the test is to determine the number of load cycles to failure at different load amplitudes. The results enable the generation of *S/N*-curves for the selected sandwich and load parameters.

Another task is the control and determination of the deflection behaviour during loading, to determine the point (load cycle number) at which core damage first occurs. This point is detectable by an increase of the deflection amplitude at constant load amplitude.

There are two different tests with different capabilities:

- Samples at low and medium load levels under a large number of load cycles.
- Samples at high load level under a small number of load cycles.

The load level and the number of cycles are given in Table 29-1.

For endurance tests, i.e. test of ultimate life, 10^6 load cycles are suggested with a test frequency of about 10Hz.

Table 29-1: Testing: Dynamic test load levels and number of cycles

Load level	% of Static ultimate load	Cycles	Frequency (Hz)
High, S1	80	~500	~50
Medium, S2	60	~5 000	~50
Low, S3	45	~50 000	~50

The load levels given are estimations that can be adjusted depending upon the real number of load cycles supported by the first sample to be tested.

The load and deflection amplitudes are recorded during the dynamic test. For high and medium numbers of load cycles, records are taken at chosen intervals. They show increased deflection caused by the damage growth during loading. The load amplitude is kept constant.

29.4.2 Static residual strength test

Residual strength tests are conducted at various points during the dynamic loading test. The purpose of the test is to determine the static residual strength of samples subjected to different numbers of dynamic load cycles.

The points at which dynamic loading is stopped in order to conduct a residual strength test are determined from the dynamic test records; as shown in Figure 29-8.

Points N_2 and N_5 are known from sinusoidal testing, whereas the other points are chosen depending on fixed values, [See also: Table 29-1].

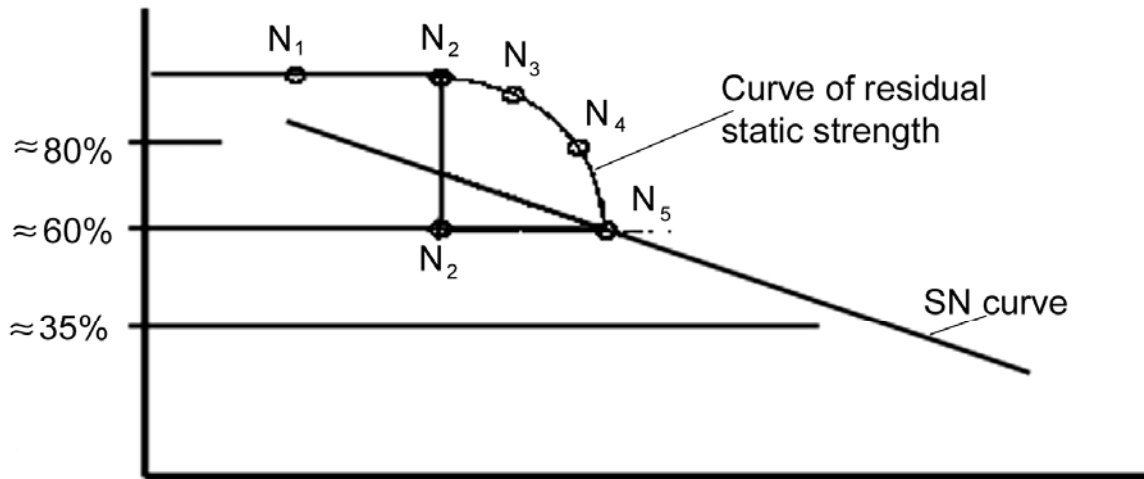

Definition of test points for residual strength

- N₂ - Load cycle number at first damaging
- N₅ - Ultimate load cycle number

Figure 29-8: Testing: Determination of points for residual strength test

29.5 References

29.5.1 General

- [29-1] L. Syvänen et al : Patria Finaviacomp Oy, Finland
 'Analysis models for insert design rules in sandwich panels with CFRP facings'
 Patria report: GS1-PFC-RP-0002 (January 2003)
 ESTEC Contract No. 14076/99
- [29-2] ASTM F606
 Standard test methods for determining the mechanical properties of externally and internally threaded fasteners, washers, and rivets

Annex A Inserts

A.1 Introduction

Inserts used in European space applications are summarised, [29-3], [29-4], [29-5]. These are grouped as:

- Commercially available, i.e. standard specified items, that are normally supplied by Shur-lok®, [See also: A.2];
- Non standard, i.e. designed and manufactured 'in-house' for particular project applications, [See: A.3] and covers those:
 - based on 'conventional' insert designs, where dimensions or the materials used are different;
 - novel insert designs, e.g. Carbon-fibre tube inserts, [See: A.3], which were originally developed for the ROSETTA Lander project, [See also: F.6 for case study].

[See also: Annex F - Case studies]

A.2 Commercial products

Table A.02.1 summarises an industry survey of insert technology, [29-3], and compilation of insert applications in European space projects, [29-4].

NOTE [29-4] covers axi-symmetrical inserts fitted in sandwich panels only.
Co-curing panels with inserts and edge inserts are excluded.

All commercially available products were supplied by Shur-lok®.

[See also: Annex F for case studies]

Table A-1: Commercially available inserts used in space

	Product Code	Comment/Project	Company/ [References]
Supplier: Shur-lok®	ENN 366	AA2024 (3.1354.T851); anodised to MIL-A-8625	DASA-RI [29-3]
	ENN 379	AA2024 (3.1354.T851); anodised to MIL-A-8625	DASA-RI [29-3]
	ENN 398	AA2024 (3.1354.T851); anodised to MIL-A-8625	DASA-RI [29-3] Alenia-Spazio [29-3]
	LN 9038	-	Alenia-Spazio [29-3]
	LN 9499	-	Alenia-Spazio [29-3]
	NAS 1834	-	BAe Airbus [29-3]
	NAS 1836	-	BAe Airbus [29-3]
	SL 100530	CASE SPOT 5: Equipment [See: F.7 - Case study]	SONACA [29-4]
	SL 10068	SILEX: Structure; Equipment [See: F.9 - Case study]	MAN Tech. [29-4]
	SL 10068	NILESAT (battery): Structure; panel assembly; satellite interface. [See: F.11 - Case study]	BTS [29-4]
	SL 10196-08	-	BAe Airbus [29-3]
	SL 10218 H3-9 4/Z	-	Contraves [29-3]
	SL 10218 M4-9 4/Z	-	Contraves [29-3]
	SL 10253	-	BAe Airbus [29-3]
	SL 10414	Steel; cadmium plated	Westlands [29-3]
	SL 10417	Steel; cadmium plated	Westlands [29-3]
	SL 10571	Steel; cadmium plated	Westlands [29-3]
	SL 10807	-	Alenia-Spazio [29-3]]
	SL 10807	-	CASA [29-3]
	SL 10968	-	CASA [29-3]
	SL 600	-	BAe Airbus [29-3]
	SL 601	-	Alenia-Spazio [29-3]
	SL 601 M4 9.5A	UMS-SST: Structure [See: F.8 - Case study]	Aerospatale [29-4]
	SL 601 M6 15.9S	ASAP 4 (AR4): Structure; equipment; I/F micro-satellite [See: 0 - Case study]	UTA Industrie [29-4]
	SL 604	-	BAe Airbus [29-3]
	SL 606	-	Alenia-Spazio [29-3]
	SL 607	Steel; cadmium plated	Westlands [29-3]
	SL 607	ARIANE 4: Equipment [See: F.3 - Case study]	CASA [29-4]
SL 607	ARIANE 5: Equipment [See: F.5- Case study]	MMS-UK [29-4]	

A.3 Non-standard

Table A-2 summarises an industry survey of insert technology, [29-3], and compilation of insert applications in European space projects, [29-4].

Non standard inserts can be grouped as:

- In-house, or
- Novel design

NOTE [29-4] covers axi-symmetrical inserts fitted in sandwich panels only.
Co-curing panels with inserts and edge inserts are excluded.

[See also: Annex F for case studies]

A.3.1 In-house

Inserts are designed and manufactured 'in-house' where commercially-available standard inserts are inadequate, e.g. through-the-thickness inserts in thick sandwich panels.

'In-house' inserts tend to follow the conventional insert design, e.g. metallic components potted into sandwich panels; with the use of nuts, bolts and helicoils as the mechanical connection method.

A.3.2 Novel design

Significant advantages with respect to mass saving, insert density per area, or assembly efforts can be achieved in cases where classically-potted all-metal inserts can be replaced by novel designs. This is demonstrated by the Carbon fibre tube inserts, originally developed for ROSETTA Lander, [See also: F.6].

Table A-2: Non standard inserts used in space applications

	Description	Project/Comment	Company/ [References]
Supplier: In-house	AA 2024-T351	HRG CL: Electronic equipment [See: F.10 - Case study]	MATRA Def. [29-4]
	AA 2024-T4	ARIANE 4: Structure handling [See: F.4 - Case study]	CASA [29-4]
	Aluminium	-	Urenco [29-3]
	Aluminium (AA7075; AA6061); Titanium (TA6V; T40); co-cured with panel	-	Alcatel Espace [29-3]
	Aluminium alloy, anodised. Through-thickness; high loads	-	Alenia-Spazio [29-3]
	Through-thickness	-	Contraves [29-3]
	Through-thickness; AA 2024-T6	ASAP 4 (AR4): Structure [See: F.4 - Case study]	UTA Industrie [29-4]
	Through-thickness; AA 7075-T73	SILEX GEO: Structure [See:F.9 - Case study]	MAN Tech. [29-4]
	Through-thickness; AA 7075-T7351 or AA7175-T7351	NILESAT (battery): Structure handling; radiator plate. [See:F.11 - Case study]	BTS [29-4]
	Through-thickness; AA 7175-T7351	SPOT 5: I/F platform structure [See:F.7 - Case study]	SONACA [29-4]
	Through-thickness; AA 7175-T7351	ASAP 5: Structure; separation system mini- and micro-satellites [See: F.5 - Case study]	MMS-UK [29-4]
	Through-thickness; Aluminium AU4G1-T351	UMS-SST: Structure [See:F.8 - Case study]	Aerospatiale [29-4]
	Through-thickness; spools	-	CASA [29-3]
	Aluminium	-	Raufoss [29-3]
	Carbon fibre tube inserts (with a spreadable CFRP tube bonded in the core and with metallic end-caps)	ROSETTA Lander, ESA study on carbon fibre tube inserts [See: F.6 - Case study]	DLR [29-5]

A.3.3 Carbon fibre tube inserts

Carbon fibre tube inserts were at first developed by DLR for use on the Lander of ESA's cornerstone mission ROSETTA, [See also: F.6]. In 2003/04 they were investigated more thoroughly in the course of an ESA-funded study, [29-5].

Figure A-1 shows the design principle in comparison with a classical potted insert, [29-5].

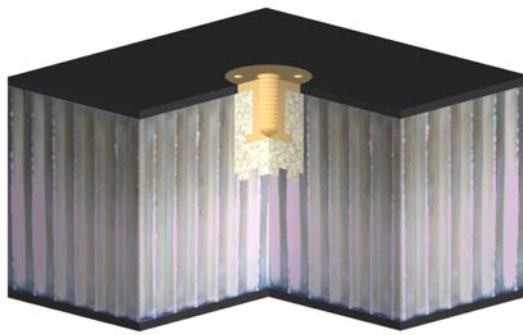

Classic potted insert

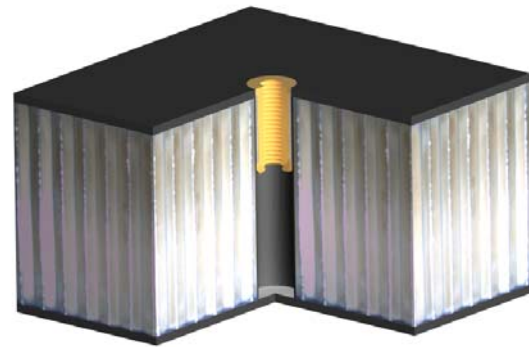

Carbon fibre tube insert

Figure A-1: Carbon fibre tube inserts: Comparison of design principles

The load introduction from the metallic insert part into the sandwich is not performed by conventional epoxy resin potting, but by means of an extremely stiff, thin-walled carbon fibre tube which fits exactly between the face sheets and is bonded to the honeycomb core by an epoxy adhesive layer. This adhesive layer can be relatively thin. Only a small amount of resin is needed to ensure good contact with the surrounding cell walls of the honeycomb core.

However, the full length of the (extremely stiff) carbon fibre tube actively contributes to the shear load transfer into the (much softer) honeycomb core, because the tube always goes through the whole sandwich thickness. The form-locking contact under both face sheets makes the sandwich in the vicinity of the insert practically incompressible.

The carbon fibre tube contains unidirectional high-modulus carbon fibres and is slit lengthways during manufacture. This allows folding or overlapping to reduce the diameter for feeding it through the borehole in the face sheet; shown in Figure A-2.



Figure A-2: Carbon fibre tube inserts: Fitting of spreadable CFRP tube

After placement, the carbon fibre tube is spread and aligned by means of a simple tool, so that the ends of the tube fit just underneath the face sheets. The inner radius of the tube is identical with the bore hole radius of the face sheets.

After curing of the adhesive, the carbon fibre tube is ready for fitting of one or two metallic insert caps. Two basic types have been developed. These are known as, [29-5]:

- Type 1, which replaces the conventional through-the-thickness insert; as shown in Figure A-3.
- Type 2, which replaces the conventional potted insert; as shown in Figure A-4.

A.3.3.2 Type 1

A thread element is inserted into the bottom sandwich face, i.e. opposite to the side from which the screw is fitted. The smaller metallic cap on the top side serves only as a guiding element for the screw. It can either be flush or protrude beyond the surface by any distance needed, [See: Figure A-3].

Type 1 tube inserts are particularly suited for high forces, where both face sheets contribute to the load-carrying capability.

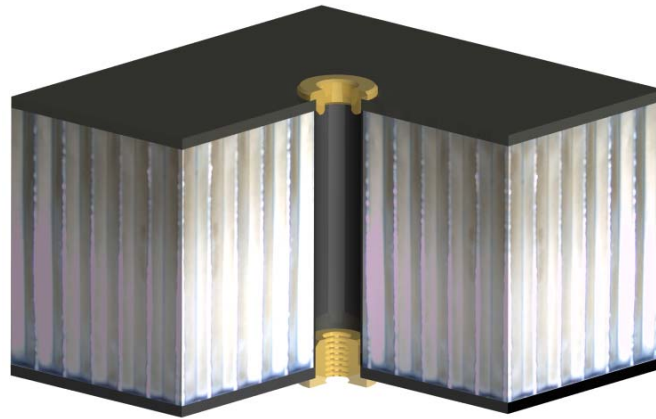

Figure A-3: Carbon fibre tube insert: Type 1 cap

A.3.3.3 Type 2

Figure A-4 shows Type 2, which needs only a single metallic cap; this replaces the conventional potted insert, e.g. used for unilateral fixation of payload units.

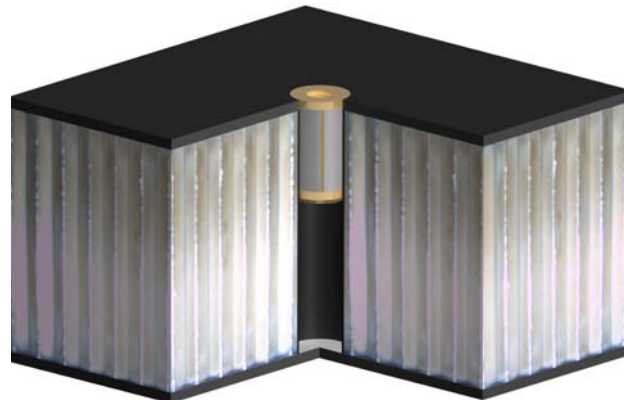

Figure A-4: Carbon fibre tube insert: Type 2 cap

The cylindrical metallic part has collars at the top and bottom; shown in Figure A-5. The standard diameter of these collars is 11mm, corresponding to the inner diameter of the carbon fibre tube insert.

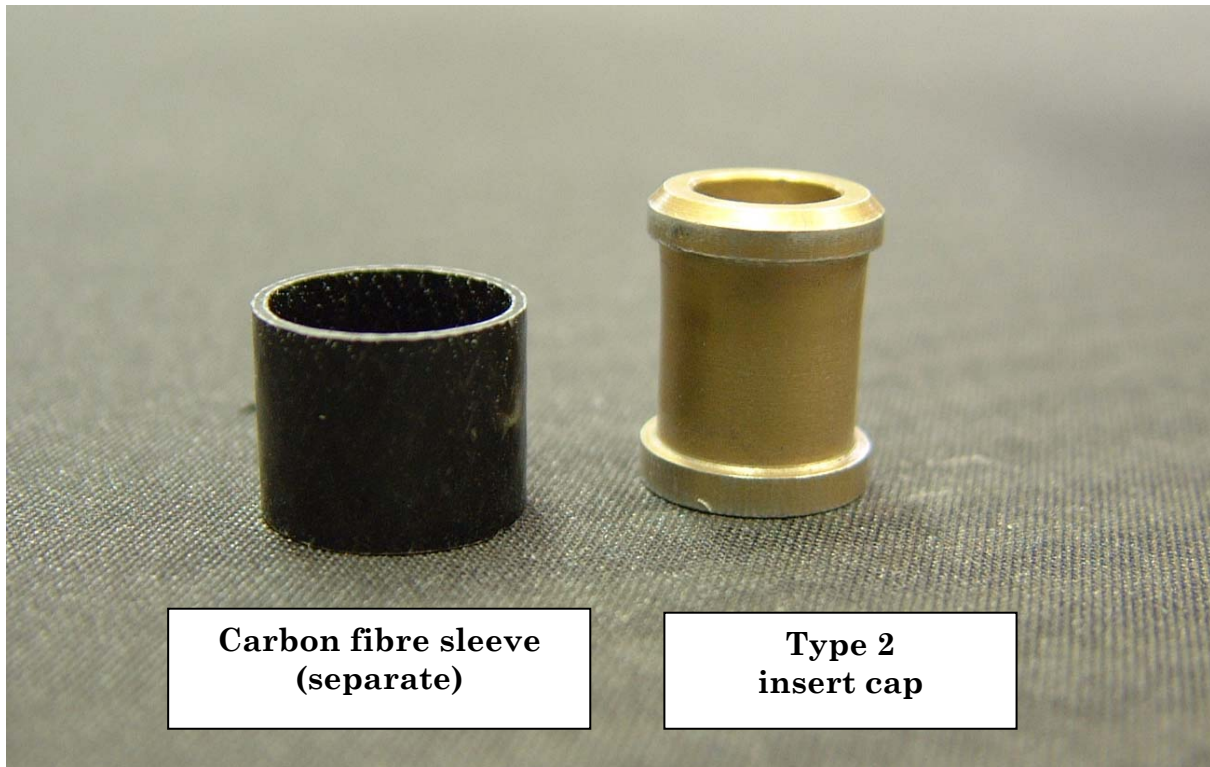

Figure A-5: Carbon fibre tube insert: Type 2 insert cap and carbon fibre sleeve

Between the two collars, the radius is reduced by 0.7 mm to enable a slit carbon fibre sleeve of 0.6 mm wall thickness to 'snap' around it. When the assembled cap is bonded into the carbon fibre tube insert, the 0.1 mm clearance is for the adhesive layer. The carbon fibre sleeve is cut precisely to length so that, once snapped around the metallic part, accurate form-locking contact between the two collars is achieved and any slipping is avoided.

The length of the Type 2 cap determines the size of the bonded area between the carbon fibre sleeve on the cap and the carbon fibre tube in the sandwich. The load-bearing capability can be chosen accordingly. Good adhesive bonding can be readily achieved between the two CFRP components.

[See also: F.6 for experimental and analytical results, [29-5]]

A.3.3.4 Advantages

Three significant advantages of carbon fibre tube inserts are:

- **Close mounting:** The radius of a carbon fibre tube insert, consisting of the radius of the tube itself plus a thin adhesive layer, is smaller than the radius of a conventional potted insert of equivalent load-bearing capability. Consequently the insert density per area of the sandwich can be higher.
- **Mass saving :** Due to the low weight of the carbon fibre tubes and the small amount of adhesive needed, the mass contribution is only ~0.05 grammes per millimetre of sandwich thickness plus the mass of the metallic insert cap (from 1.9 g for M3 up to 3.2 g for M6). This is significantly lighter than comparable potted inserts for sandwich thicknesses up to 50 mm. For very thick sandwiches, carbon fibre tube inserts may become slightly heavier (due to the long tube) but their out-of-plane load-bearing capability is far superior.

- Easy implementation: The implementation of carbon fibre tube inserts into bore holes in the sandwich is relatively easy. Special expertise and training regarding the proper injection of potting compound is not necessary. This can play a part in reducing costs.

A.3.4 Other novel designs

As carbon fibre tube inserts have successfully demonstrated, significant advantages regarding mass saving, a real insert density or assembly effort can be achieved in cases where conventionally-potted, all-metal inserts can be replaced by novel designs.

Similar developments, which are currently the subject of evaluation exercises, will be included in future handbook revisions.

A.4 References

A.4.1 General

- [29-3] Insert Technology Industry Survey (1995)
- [29-4] 'Matra Marconi Space Contribution to ESA Insert Design Handbook';
MMS Ref. NT/102/BG/355013.96 (Dec. 1996)
- [29-5] J. Block, R. Schütze, T. Brander, K. Marjoniemi, L. Syvänen, M. Lambert:
DLR Braunschweig/Helsinki Univ. Technology/Patria/ESA/ESTEC
'Study on Carbon Fibre Tube Inserts'
ESTEC Contract No. 16822/02/NL/PA, (2004)

Annex B

Permissible loads

B.1 Introduction

The set of design graphs, presented in B.2, are based on the analytical expressions for:

- Predicting static load-carrying capability of inserts subjected to out-of-plane loading, [See: D.1].
- Reliability coefficients RC , [See: D.7; Table D-2]

This Annex presents graphs of:

- Tensile permissible loads.
- Compressive permissible loads.

NOTE See: B.2 for index to design graphs
See also: D.8 for a description of the graphs.

B.1.1 Core types

The types of cores are grouped as:

- Metallic, [See also: Table 6-3].
- Non metallic, i.e. Nomex® or GFRP glass fibre-reinforced plastic, [See also: Table 6-4].

B.1.2 Core height

B.1.2.1 Permissible tensile loads

Although the graphs are plotted up to core heights of 60 mm, recent work has queried their accuracy for greater core heights, [29-6].

As core height increases from about 40 mm to 60 mm typically, there is a 'transition point' at which the insert behaviour changes from 'fully potted', i.e. small core heights; to a 'partially potted' response and 'potting rupture'.

Above the transition point, both the calculated minimum and average permissible tensile loads, [29-6] are lower than those shown on the design graphs. Table B-1 summarises transition points for four insert-sandwich configurations, [29-6].

The difference between values can be between 20% and 60%, depending on the particular insert-sandwich panel configuration. An example is shown in Table B-2.

When the core height approaches 40 mm, the permissible tensile load is determined for all three potting behaviours, i.e. fully potted, partially potted and potting rupture; and the lowest value obtained is applied; as shown in Table B-2.

NOTE This applies to tensile permissible loads only. Compression permissible loads do not show such a 'transition' effect.

Table B-1: Core height: Permissible tensile loads - transition points

Core	Insert (mm)		Face sheet (mm) thickness	Transition point ⁽¹⁾ Core height (mm)	
	dia.	height		Min.	Ave.
	3/16-5056-0.0007	14	9	0.2	42
3/16-5056-0.0007	14	9	0.4	43	46
3/16-5056-0.0007	14	9	0.6	42	45
3/16-5056-0.0007	14	9	0.8	38	44

NOTE ⁽¹⁾ Transition from 'fully potted' to 'partially potted' behaviour.

Table B-2: Core height: Example - permissible tensile loads

Method	Minimum tensile permissible load (N)		
	Fully potted	Partially potted	Potting failure
Calculated, [29-6]	2200	1748	1896
From IDH, [29-7]	2200	-	-
NOTE	Core: Type 3/16-5050-0.0007; height: 55 mm; Insert: diameter = 14 mm; height = 9 mm; Face sheet thickness = 0.4 mm		

B.2 Index to permissible-load graphs

Table B-3 lists some of the typical combinations of honeycomb cores used in sandwich panels in which inserts are potted.

The graphs are accessed by links in the 'core designation' column, which shows the available plots for standard inserts of various common sizes loaded in tension or compression. Links to each of the individual graphs can then be selected.

NOTE 1 Not all available core and insert combinations are plotted, so the graphs illustrate the behaviour of common insert and sandwich panel combinations.

NOTE 2 All the graphs are reproduced from the previous version of the insert design handbook, [29-7]. Any errors in either the original graphs, or resulting from redrawing, mean that the graphs cannot to be used for design purposes without further verification.

Table B-3: Design graphs: Index to permissible static loads

Core Type	Core Designation ⁽¹⁾
Aluminium alloy	3/16-5052-0.0007
	3/16-5052-0.001
	1/8-5052-0.0007
	1/8-5052-0.001
	3/16-5056-0.0007
	3/16-5056-0.001
	1/8-5056-0.0007
	1/8-5056-0.001
Nomex [®] (aramid-type fibre/phenol resin)	HRH 10-3/16-2.0
	HRH 10-3/16-3.0
	HRH 10-3/16-4.0
	HRH 10-1/8-1.8
	HRH 10-1/8-3.0
	HRH 10-1/8-4.0
GFRP (glass fibre reinforced plastic)	HRP-3/16-4.0
	HRP-3/16-5.5
NOTE ⁽¹⁾ Aluminium alloy: cell size - core alloy - foil thickness. Nonmetallic: material - cell size - density.	

B.3 References

B.3.1 General

- [29-6] M.-A Gyax: Contraves Space (CH):
 'ESA-PSS-03-1202 Issue 1 Rev.1 - Fax communication to ESTEC'; October 1997
- [29-7] ESA-PSS-03-1202 (Issue 1, Revision 1) September 1990: Insert design handbook

Annex C

Analytical determination

C.1 Introduction

The analysis presented in Annex C applies to the determination of the static capability of an insert in a large sandwich panel, with the load normal to the panel.

NOTE The principles discussed here relate to the MBB-ERNO-derived 'antiplane theory'. An 'extended antiplane theory' is presented in Annex D.

C.1.1 How to use the formula

C.1.1.1 Determine full or partial potting

The relationship between the insert height, potting height and the core height determine which analytical approach is used.

If the insert height h_i or the potting height h_p coincide with the core height c , then the insert is truly fully potted.

The insert capability P_{crit} is determined by using equations given in:

- C.2: (Eqn. [C.2-10]); (Eqn. [C.2-14]); (Eqn. [C.2-15]); (Eqn. [C.2-6]); (Eqn. [C.2-17]);
- C.5: (Eqn. [C.5-1]) for compression load and thick facing sheets. If the insert height h_i and, especially, the potting height h_p are smaller than the core height c , two insert capability values are determined:
 - P_{crit} of an identical insert system which is assumed to be fully potted;
 - $P_{p\ crit}$ of the partially potted insert, using:
 - C.3: (Eqn. [C.3-10]); (Eqn. [C.3-11]);
 - C.5: (Eqn. [C.5-2]) for compression load and thick face sheets

The lower value of insert capability is important:

- $P_{crit} < P_{p\ crit}$: the partially potted insert behaves like a fully potted insert.
- $P_{p\ crit} < P_{crit}$: the partially potted insert behaves like a partially potted insert.

[See also: Figure C-1 and Figure C-2]

C.1.2 Potting resin

The potting resin fails if, simultaneously:

- $P_{R \text{ crit}} < P_{\text{crit}}$, and
- $P_{R \text{ crit}} < P_{\text{pcrit}}$

Tensile rupture of the potting resin should be avoided. This is described in C.3 and C.4; using supplementary equations: (Eqn. [C.3-11]); (Eqn. [C.4-3]); (Eqn. [C.4-11]); (Eqn. [C.4-12]).

C.1.3 Validity of equations

The validity of the formulae presented in Annex C, based on those in [29-9] , [29-10], have been proven in [29-11], [29-12].

C.1.3.1 Boundary conditions

The equations cited, particularly the fundamental (Eqn. [C.2-1]), are valid independent of the outer boundary conditions of the panel, provided that the panel radius, a , is large enough.

If $a > 2b$, the critical area near the insert, where τ_{max} occurs, is determined with an acceptable accuracy.

C.1.3.2 Clamped inserts

The equations are valid only for a clamped insert, which is the usual case.

C.2 Fully potted insert

NOTE See: C.1 to determine full or partial potting.

The shear stress distribution in the core of a circular sandwich panel with a rigid, central and clamped insert subjected to normal load is given by, [See also: 12.2]:

$$\tau(r) = \frac{P I_p}{\pi(h+c)I} \times \left(\frac{1}{r} - \frac{I_1(\alpha r)}{a b_p} \frac{b_p K(\alpha b_p) - a K_1(\alpha a)}{I_1(\alpha a) \times K_1(\alpha b_p) - I_1(\alpha b_p) \times K_1(\alpha a)} - \frac{K_1(\alpha r)}{a b_p} \frac{a I_1(\alpha a) - b_p I_1(\alpha b_p)}{I_1(\alpha a) \times K_1(\alpha b_p) - I_1(\alpha b_p) \times K_1(\alpha a)} \right)$$

[C.2-1]

Where:

- $\tau(r)$ shear stress in the core at radius r ; as shown in Figure C-1.
- P applied out-of-plane load
- τ core shear stress
- t_s face sheet thickness; assumed that both face sheets are similar
- h total sandwich thickness = $c + t_{s1} + t_{s2}$
- α outer radius of panel
- b_p effective potting radius
- b_R real potting radius
- I_p moment of inertia of the panel

$$= \frac{t_{s1} t_{s2} (h+c)^2}{4(h-c)}$$

I_s moment of inertia of the face sheets

$$= \frac{t_{s1}^3 + t_{s2}^3}{12}$$

$I = I_p + I_s$

α ratio of stiffness between core and face sheets

$$= \sqrt{\frac{G_c(h-c)I}{E c t_{s1} t_{s2} I_s}}$$

G_c shear modulus of the core

$$E = \frac{E_s}{1-\nu_s^2}$$

$I_1(x), K_1(x)$ Bessel functions, where $x = \alpha r, \alpha a, \alpha b$

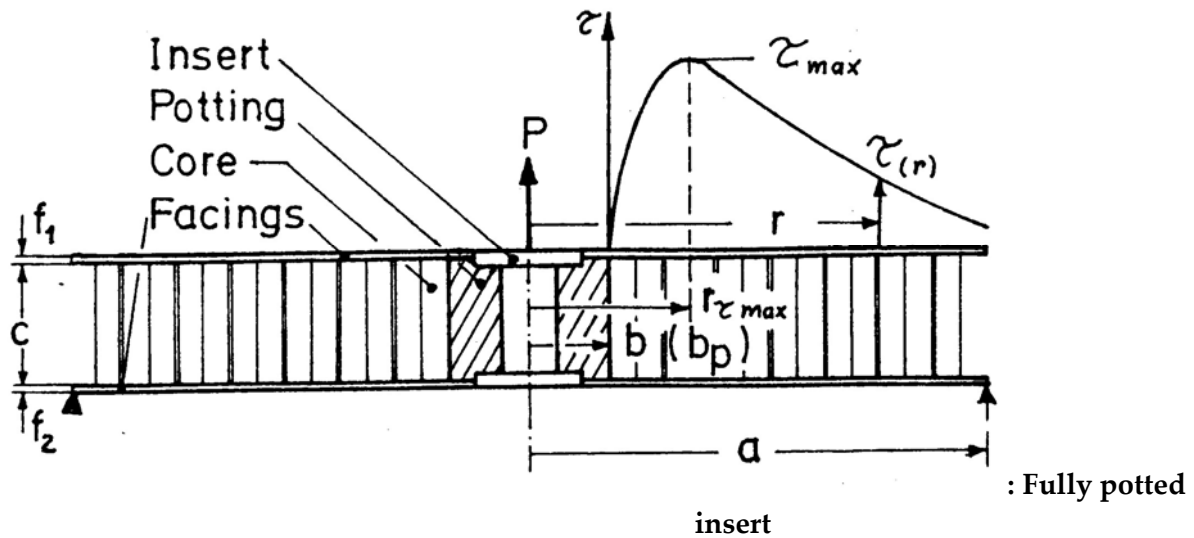

For $\alpha r, \alpha a$ and $\alpha b > 5$, the modified Bessel functions become the exponential functions:

$$I_1(x) = e^x (2\pi x)^{-1/2} \tag{C.2-2}$$

$$K_1(x) = -e^{-x} (\pi/2x)^{1/2}$$

Substitution of (Eqn. [C.2-2]) into (Eqn. [C.2-1]) gives:

$$\tau(r) = \frac{PI_m}{\pi b(h+c)I} K \tag{C.2-3}$$

With:

$$K = \frac{b}{r} \left[1 - \sqrt{r} \frac{\sqrt{b} (e^{\alpha(r-b)} - e^{-\alpha(r-b)}) + \sqrt{a} (e^{\alpha(a-r)} - e^{-\alpha(a-r)})}{\sqrt{ab} (e^{\alpha(a-b)} - e^{-\alpha(a-b)})} \right] \tag{C.2-4}$$

Or:

$$K = \frac{b}{r} \left[1 - \sqrt{r} \frac{\sqrt{b} \sinh \alpha(r-b) + \sqrt{a} \sinh \alpha(a-r)}{\sqrt{ab} \sinh \alpha(a-b)} \right] \quad [\text{C.2-5}]$$

For $r < a$, a good approximation for K is:

$$K = \frac{b}{r} \left[1 - \sqrt{\frac{r}{b}} e^{\alpha(b-r)} \right] \quad [\text{C.2-6}]$$

For $f' = f$, by rearrangement of the equations:

$$I_m = f(c + f)^2 / 2$$

$$I_f = f^3 / 6$$

$$I = f(c^2 / 2 + cf + 2f^2 / 3)$$

$$\alpha = \frac{1}{f} \sqrt{\frac{G_c}{E_f} 12(1 - \nu_f^2) \left(\frac{\beta}{2} + 1 + \frac{2}{3\beta} \right)} \quad [\text{C.2-7}]$$

$$\tau(r) = \frac{P}{2\pi bc} \frac{\beta(\beta+1)}{(\beta^2 + 2\beta + 4/3)} K \quad [\text{C.2-8}]$$

With:

$$\beta = c/f \quad [\text{C.2-9}]$$

For $\beta \geq 10$, i.e. $c \geq 10$ mm and $f \leq 1$ mm, (Eqn. [C.2-7]) and (Eqn. [C.2-8]) can be approximated by:

$$\alpha = \frac{1}{f} \sqrt{\frac{G_c}{E_f} 12(1 - \nu_f^2) \left(1 + \frac{\beta}{2} \right)} \quad [\text{C.2-10}]$$

$$\tau(r) = \frac{P}{2\pi bc} \frac{\beta}{\beta+1} K \quad [\text{C.2-11}]$$

With an error of less than 0.5%.

The core shear stress distribution can be expressed by:

$$\tau(r) = \tau_{\text{nom}} C^* K \quad [\text{C.2-12}]$$

With:

$$\tau_{nom} = p / 2\pi bc \quad [C.2-13]$$

$$C^* = \beta / (\beta + 1) \quad [C.2-14]$$

$$K = \frac{b}{r} \left[1 - \sqrt{\frac{r}{b}} e^{\alpha(b-r)} \right] \quad [C.2-6]$$

$$r_{\tau max} = \frac{b}{\left[1 - e^{c_2(\alpha b)^n} \right]} \quad [C.2-15]$$

With:

$$C_2 = -0.931714$$

$$n = 0.262866$$

The value of $r_{\tau max}$ is used in (Eqn. [C.2-6]) to obtain K_{max} that is used in (Eqn. [C.2-1]) to give:

$$\tau_{max} = \tau_{nom} C^* K_{max} \quad [C.2-16]$$

If τ_{max} reaches the core shear strength τ_{crit} , the insert capability is given by:

$$P_{crit} = \frac{(2\pi bc \tau_{crit})}{C^* K_{max}} \quad [C.2-17]$$

NOTE Eqn. [C.2-17] is valid for both tensile and compressive loads.

C.3 Partial potting

The evaluation covers partially potted inserts in:

- Metallic core;
- Non-metallic core, e.g. GFRP, Nomex®.

NOTE See: C.1 to determine full or partial potting.
 See: C.2 for fully potted insert.

C.3.1 Metallic core

For a partially potted insert in an aluminium core, the load P_p applied to the insert-sandwich system has three component parts, as shown in Figure C-2:

- P_F : load component carried by the upper face sheet;
- P_S : load component carried as shear stress in the core around the potting;
- P_N : load component carried by normal stress in the core under the potting.

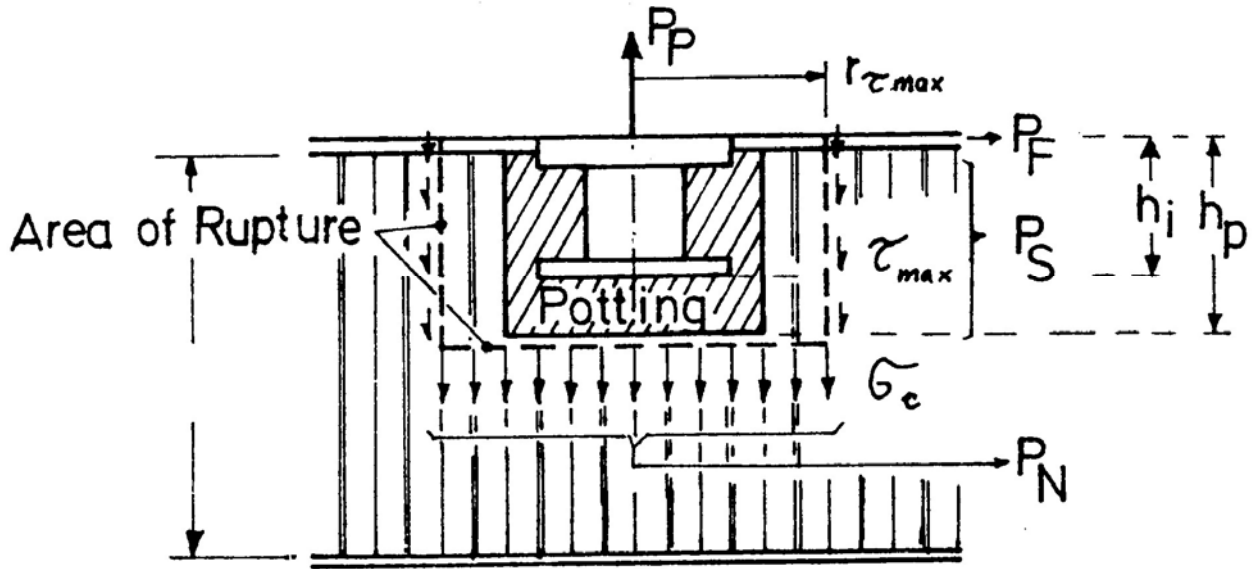

Figure C-2: Partially potted insert

These load components are given by:

$$P_F = \frac{(P_{\tau_{max}} - 2\pi r_{\tau_{max}} c \tau_{max})}{2} \quad [C.3-1]$$

$$P_S = 2\pi r_{\tau_{max}} h_p \tau_{max} \quad [C.3-2]$$

$$P_N = \pi r_{\tau_{max}}^2 \sigma_c \quad [C.3-3]$$

With:

$$P_{\tau_{max}} = \frac{2\pi b c \tau_{max}}{(C * K_{max})} \quad [C.3-4]$$

This is the load of a fully potted insert corresponding to τ_{max} , which becomes P_{crit} for $\tau_{max} = \tau_{c\ crit}$ from (Eqn. [C.2-17]).

where:

$r_{\tau_{max}}$ = distance of maximum core shear strength from insert centre, from (Eqn.[C.2-15])

σ_c = normal stress in the core beneath the potting;

which are:

σ_{ct} = tensile stress for tensile load;

σ_{cc} = compressive stress for compressive load.

h_p = potting height.

For an insert with a height of h_i , the minimum potting height necessary is:

$$h_{p\ min} = h_i + 7 \dots mm \quad [C.3-5]$$

NOTE 7 mm is used whatever the core height, C .

The typical value of h_p depends on the core height:

$$h_{p\text{ typ}} = h_{p\text{ min}} + A \tanh(c - h_{\text{min}}) / h_{p\text{ min}} \quad [\text{C.3-6}]$$

Where:

$A = 5$ for cell size $S_c = 4.8\text{mm}$ (1/8" core);
 $A = 2.5$ for cell size $S_c = 3.2\text{ mm}$ (3/16" core).
 \tanh is a hyperbolic tangent

NOTE Eqn. [C.3-6] is only valid for partial potting, i.e. $c > h_i + 7\text{ mm}$.

- P_S : is limited by the core shear strength $\tau_{c\text{ crit}}$.
- P_N : is limited by the core:
 - tensile strength $\sigma_{c\text{ crit t}}$;
 - compressive strength $\sigma_{c\text{ crit c}}$;

Theoretically, for a linear behaviour, the two failure modes do not occur together, i.e.:

- shear rupture;
- tensile (or compressive) rupture of core.

But in reality, owing to non-linearity effects, the shear strength and the tensile (or compressive) strength of the core are reached together.

Therefore the components of the critical load of partially potted inserts are:

$$P_{F\text{ crit}} = \frac{(P_{\text{crit}} - 2\pi r_{\text{max}} c \tau_{c\text{ crit}})}{2} \quad [\text{C.3-7}]$$

$$P_{S\text{ crit}} = 2\pi r_{\text{max}} h_p \tau_{c\text{ crit}} \quad [\text{C.3-8}]$$

$$P_{N\text{ crit}} = \pi r_{\text{max}}^2 \sigma_{c\text{ crit}} \quad [\text{C.3-9}]$$

Where:

$\sigma_{\text{crit}} = \sigma_{c\text{ crit t}}$ for tensile load;
 $\sigma_{\text{crit}} = \sigma_{c\text{ crit c}}$ for compressive load.

Thus, the capability of a partially potted insert is given by:

$$P_{p\text{ crit}} = \frac{1}{2} P_{\text{crit}} + \pi r_{\text{max}} (2h_p - c) \tau_{c\text{ crit}} + \pi r_{\text{max}}^2 \sigma_{c\text{ crit}} \quad [\text{C.3-10}]$$

C.3.2 Non-metallic core

Owing to the inability of rigid, non-metallic cores, e.g. GFRP and Nomex[®], to distribute stress concentrations by deforming locally, the insert capability only increases slightly for constant h_p with increasing core height, c .

The stress concentration for a partially potted insert is considered to be conservatively covered by:

$$P_{ss\text{ pp}} = P_{ss\text{ fp}} \frac{1}{K_{t\text{ pp}}} \quad [\text{C.3-11}]$$

Where:

$P_{ss\text{ pp}}$ = Permissible load of a partially potted insert ($h_p < c$).

From (Eqn. [C.2-17]):

$$P_{ss_{pf}} = \frac{2\pi b_p c \tau_{c_{crit}}}{C * K_{max}} \quad [C.3-12]$$

Where:

$P_{ss_{pf}}$ = Permissible load of a partially potted insert ($h_p = c$).

$$\frac{1}{K_{t_{pp}}} = \left(\frac{h_p}{c} \right)^{0.62} \quad [C.3-13]$$

Where:

$1/K_{t_{pp}}$ = Stress concentration factor.

For $c > 2.5 h_p$, the permissible load of a partially potted insert in a non-metallic core is considered quasi-linear.

C.4 Potting failure

The analysis covers failure of the potting resin underneath an insert, for:

- Partial potting;
- Heavy cores having high tensile strengths:
 - metallic (see C.4.1)- aluminium;
 - non-metallic (see C.4.1.2), e.g. GFRP, Nomex®.

NOTE This type of failure only occurs under tensile load.

C.4.1 Heavy metal core

The load P_R applied to an insert-sandwich system has three component parts, [See also: C.3; Figure C-2]:

- P_F : load component carried by the upper face sheet, given by:

$$P_F = \frac{1}{2} (P_{\tau_{max}} - 2\pi r_{\tau_{max}} c \tau_{max}) \quad [C.3-1]$$

- P_{SR} : load component carried as shear stress in the core around the potting, over the insert height, given by:

$$P_{SR} = 2\pi r_{\tau_{max}} h_i \tau_{max} \quad [C.4-1]$$

- P_{NR} : load component carried by normal stress in the potting resin under the insert:

$$P_{NR} = \pi b_R^2 \sigma_R \quad [C.4-2]$$

Where:

h_i = insert height;

b_R = real potting radius, [See: Note];

σ_R = tensile strength of the potting;

$$P_R = P_F + P_{SR} + P_{NR} \quad [C.4-3]$$

NOTE b_R is not identical to the 'equivalent potting radius', b in C.2, [See also: 7.4].

P_{NR} can also be expressed by:

$$P_{NR} = P_F + (P_R - 2P_F)(c - h_i) / c \quad [C.4-4]$$

$$= P_F(1 - 2\psi) + P_R\psi$$

Where:

$$\psi = (c - h_i) / c \quad [C.4-5]$$

$$P_F = P_{NR} / (1 - 2\psi) - P_R\psi / (1 - 2\psi) \quad [C.4-6]$$

C.4.1.2 Spreadsheet users

NOTE Eqn. [C.4-6] becomes singular when $c = 2 \times h_i$ and can produce a 'divide by zero' error when using a spread sheet.

Users of spread sheet-type applications are advised to use an alternative derivation for P_R , [29-8].

[See: Notes for spreadsheet users - Derivation of PR]

Using (Eqn. [C.2-17]) and (Eqn. [C.3-11]), P_{SR} can be expressed in terms of P_R by:

$$P_R = 2\pi b c \frac{\tau_{\max}}{C^* K_{\max}} \quad [C.4-7]$$

$$2\pi \tau_{\max} = P_R C^* K_{\max} \frac{1}{b \cdot c} \quad [C.4-8]$$

$$P_{SR} = 2\pi \tau_{\max} h_i \tau_{\max} \quad [C.4-9]$$

$$P_{SR} = P_R C^* K_{\max} r_{\max} \frac{h_i}{b \cdot c} \quad [C.4-10]$$

When (Eqn. [C.4-6]) and (Eqn. [C.4-10]) are substituted into (Eqn. [C.4-3]), the critical insert load under which the potting resin fails is given by:

$$P_{R \text{ crit}} = 2P_{NR \text{ crit}} \left[\frac{\left(\frac{1-\psi}{1-2\psi} \right)}{\frac{1-\psi}{1-2\psi} - \frac{C^* K_{\max} r_{\max} h_i}{bc}} \right] \quad [C.4-11]$$

Where:

$$P_{NR \text{ crit}} = \pi b_R^2 \sigma_{R \text{ crit}} \quad [C.4-12]$$

$\sigma_{R \text{ crit}}$ = tensile strength of potting resin.

C.4.2 Heavy non-metallic core

The permissible load P_{SS} applied to the insert-sandwich system is determined by, [See: C.3]:

$$P_{SS \text{ pp}} = P_{SS \text{ fp}} \frac{1}{K_{1 \text{ pp}}} \quad [C.3-11]$$

where:

P_{ssfp} = Permissible load of a partially potted insert ($h_p < c$).

$$P_{ssfp} = \frac{2\pi b_p c \tau_{crit}}{C * K_{max}} \quad [C.3-12]$$

$$\frac{1}{K_{t_{pp}}} = \left(\frac{h_p}{c} \right)^{0.62} \quad [C.3-13]$$

P_{SSpp} is quasi-constant for $c > 2.5 h_p$.

Potting failure of an insert in a non-metallic core is considered to occur when:

$$P_{sspp} = \pi b_R^2 \sigma_{Rcrit} \quad [C.4-13]$$

where:

b_R = real potting radius;

σ_{Rcrit} = tensile strength of potting resin.

C.4.3 Notes for spreadsheet users - Derivation of PR

In the analysis of potting failure, [See: C.4], (Eqn. [C.4-6]) becomes singular when $c = 2 \times h_i$

This can produce a 'divide by zero' error when using a spreadsheet. Users of spreadsheet-type applications are therefore advised to use this alternative derivation of P_R , [29-8].

From (Eqn. [C.2-17]):

$$P_R = \frac{2\pi b c}{C * K_{max}} \tau_{max}$$

Hence
$$\pi \tau_{max} = \frac{P_R C * K_{max}}{2bc}$$

From (Eqn. [C.3-1]):

$$P_F = \frac{2\pi b c}{2C * K_{max}} \tau_{max} - \frac{2\pi c}{2} \tau_{max} r_{\tau_{max}}$$

Hence
$$P_F = \pi \tau_{max} \left(\frac{bc}{C * K_{max}} - c r_{\tau_{max}} \right)$$

From (Eqn [C.4-1]):

$$P_{SR} = 2\pi h_i \tau_{max} r_{\tau_{max}}$$

Hence
$$P_{SR} = \frac{P_R C^* K_{\max}}{2bc} 2r_{\tau_{\max}} h_i$$

From (Eqn. [C.4-3]):

$$P_R = P_F + P_{SP} + P_{NR}$$

Hence
$$P_{NR} = P_R \left(\frac{1}{2} + \frac{C^* K_{\max}}{bc} r_{\tau_{\max}} \left(\frac{c}{2} - h_i \right) \right)$$

From (Eqn. [C.4-2]):

$$P_{NR} = \pi b_R^2 \sigma_R$$

Rearranging the above, gives:

$$P_R = \frac{\pi b_R^2 \sigma_R}{0.5 + \frac{C^* K_{\max}}{bc} r_{\tau_{\max}} \left(\frac{c}{2} - h_i \right)}$$

Thus at $c = 2 \times h_i$

$$P_R = \frac{\pi b_R^2 \sigma_R}{0.5}$$

C.5 Compressive loading

This analysis applies to compressively-loaded inserts in sandwich panels having thick face sheets, with:

- Metallic core;
- Non-metallic core.

C.5.1 Metallic core

Under compression, if the thickness of the aluminium face sheet is less than 0.6 mm, then it does not contribute to the insert capability. This is due to tensile rupture of the bond between the core and the upper face sheet near the insert.

Under these circumstances, the insert capability is reduced.

C.5.1.1 Fully potted inserts

$$P_{crit c} = \frac{P_{crit}}{2} + \pi r_{\tau_{\max}} c \tau_{c crit} \quad [C.5-1]$$

Where:

P_{crit} comes from (Eqn [C.2-17])

C.5.1.2 Partially potted inserts

$$P_{p\ crit\ c} = 2\pi r_{\tau_{max}} h_p \tau_{max} + \pi r_{\tau_{max}}^2 \sigma_{c\ crit\ c} \quad [C.5-2]$$

C.5.2 Non-metallic core

The insert capability is also reduced.

C.5.2.1 Fully potted inserts

$$P_{crit\ c} = \frac{P_{crit}}{2} + \pi r_{\tau_{max}} c \tau_{c\ crit} \quad [C.5-1]$$

Where:

P_{crit} comes from (Eqn. [C.2-17])

C.5.2.2 Partially potted inserts

$$P_{crit\ c} = \frac{P_{crit}}{2} + \pi r_{\tau_{max}} c \tau_{c\ crit} \frac{1}{K_{t_{pp}}} \quad [C.5-3]$$

Where:

$$\frac{1}{K_{t_{pp}}} = \left(\frac{h_p}{c} \right)^{0.62} \quad [C.3-13]$$

C.6 Reliability

C.6.1 Correlation coefficients

Comparison of the theoretical analysis with test results, [29-11], provided correlation coefficients, CC for the various cases considered in Annex C; as given in Table C-1, where: $CC = P_{crit\ test} / P_{crit\ theory}$

Table C-1: Correlation coefficients

Potting	Applied load	Correlation coefficient (CC) ⁽¹⁾	Standard deviation (G)
Fully potted insert, or behaving as fully potted ⁽²⁾	Tensile Compressive	0.993	0.059
Partially potted	Tensile	1.043	0.52
Partially potted	Compressive	0.998	0.072
NOTE (1) $CC = P_{crit\ test} / P_{crit\ theory}$			
NOTE (2) See also: C.1 to determine full or partial potting.			

C.6.2 Reliability coefficients

To ensure a reliability of 99%, the theoretical values are multiplied by the reliability coefficient, RC .

The minimum and averages values are given in Table C-2, [29-11].

Table C-2: Reliability coefficients

	Tensile	Tensile	Compressive
Core	Metallic perforated	Metallic un-perforated GFRP Nomex®	Metallic (all types)
Minimum value:			
RC	$= 1.172 - 0.0063 \cdot c - 0.2641 \cdot f$	0.91	0.89
Average value:			
RC	$= 1.207 - 0.00544 \cdot c - 0.2088 \cdot f$	1	1
NOTE c = core height, formerly shown as h_c , in PSS-IDH [29-13].			

C.7 References

C.7.1 General

- [29-8] S. Brown ESTEC-YME/SI IKOSS (Fax 1997)
- [29-9] Erickson, W.S. 'The bending of a circular sandwich plate under normal load', Forest Products Laboratory Report No. 1828 (1953)
- [29-10] Young, W.S. and Kuenzi, E.W. 'Stresses included in a sandwich panel by load applied at an insert', Forest Products Laboratory Report No. 1845 (1955)
- [29-11] 'Standardisation of design analysis and testing of inserts in structural sandwich elements- Final Report'. MBB-ERNO (3442/77/NL/PP)
- [29-12] 'Standardisation of design analysis and testing of inserts in structural sandwich elements- Final Report'. MBB-ERNO (3442/77/NL/PP- Rider 1)
- [29-13] ESA-PSS-03-1201 (Issue 1, Revision 1) September 1990: Insert design handbook

Annex D

Estimation of static load-carrying capability

D.1 Introduction

The approximation, presented in Annex D, applies to the determination of the static load-carrying capability of an insert in a large sandwich panel, [29-14].

NOTE As far as loads normal to the sandwich panel are concerned, the principles discussed here relate to 'extended antiplane theory'.
 [See also: Annex C for analysis by MBB-ERNO-derived 'antiplane' theory]

D.1.1 Background

The general problem of analysing a sandwich panel loaded through an insert is difficult, [See: section 8]. The constituent parts of the sandwich panel interact in complex ways in the regions close to the insert; hence in the active load-transfer mechanisms appear to be very complicated. Much of this results from local changes in the sandwich panel. The individual face sheets of the sandwich panel tend to bend about their own neutral planes rather than about the neutral plane of the sandwich panel.

From the point of view of practical design, the evident conclusion is that classical 'antiplane' sandwich theory, which is very simple, generally cannot be used for predicting the load-bearing capability of sandwich plates with inserts subjected to arbitrary external loads.

There is, however, one very important exception to this. In the case of sandwich panels with inserts loaded normal to the plane of the sandwich panel (tensile or compressive loading), the active failure mechanism is nearly always shear rupture of the honeycomb core at the interface between the potting and the honeycomb; especially by shear rupture of the undoubled core foils.

The peak shear stress in the honeycomb material is located exactly at the potting-to-honeycomb interface, and this stress component is predicted with sufficient accuracy by classical 'antiplane' sandwich theory, [[29-15] to [29-18], [29-25]; provided that the correct location is assumed for peak shear stress, $r = b_p$.

D.1.2 How to use the formulae

D.1.2.1 Determine full or partial potting

If the insert height h_i or the potting height h_p coincide with the core height c , the insert is 'through-the-thickness' or fully potted. Then, the static load carrying capability P_{crit} can be determined by:

- Tension, [See: D.3; Eqn. [D.3-2]];
- Compression loading and ‘thick’ face sheets, [See: D.6; Eqn. 0].

If the insert height h_i and, especially, the potting height h_p are smaller than the core height c , two quantities have to be determined:

- The static load-carrying capability, P_{crit} of an identical insert system, which is assumed to be fully potted (‘through-the-thickness’) using expressions:
 - tension: (Eqn. [D.3-2]), or
 - compression: (Eqn. 0).
- The static load carrying capability, $P_{p\ crit}$ of the partially potted insert using expressions for:
 - tension, [See: D.4]: aluminium core: (Eqn. [D.4-10]); non-metallic core: (Eqn. [D.4-11]).
 - compression and ‘thick’ face sheets, [See: D.6]: aluminium core: (Eqn. [D.6-1]); non-metallic core: (Eqn. [D.6-2]).

NOTE The lower of the two insert strength predictions is used.

If $P_{crit} < P_{p\ crit}$ a partially potted insert behaves like a fully potted (‘through-the-thickness’) insert.

If $P_{crit} > P_{p\ crit}$ then the partially potted insert behaves like a true partially potted insert.

In addition to the above design calculations, it is necessary to ensure that tensile rupture does not occur in the potting resin underneath the insert or underneath the potting.

This can be determined using the expressions:

- aluminium core, [See: D.5; Eqn. [D.5-9]];
- non-metallic core, [See: D.5; Eqn. [D.5-11]].

D.2 Out of plane loading

Only the shear stresses in the sandwich plate are needed, [See: D.1]. To determine the shear stresses in a large sandwich plate with an insert subjected to out-of-plane loading, it is necessary to extend the results of the simple ‘antiplane’ sandwich beam theory, [See section: 8].

The necessary extension of the classical ‘antiplane’ sandwich beam theory is easily achieved for the case of circular sandwich plate subjected to axisymmetric loading; from theory in [29-18].

In the modelling, it is assumed that the insert of radius b_i is an infinitely rigid body, but that both the potting compound and the honeycomb core are deformable in shear. This assumption is very important because an infinitely rigid potting compound (which is sometimes suggested and applied) leads to the incorrect prediction of zero shear stresses at the potting-to-honeycomb interface.

NOTE The peak honeycomb core shear stress occurs exactly at the potting-to-honeycomb interface.

Figure D-1 shows a circular sandwich plate with dissimilar face sheets with thicknesses f_1 (top face) and f_2 (bottom face), and with elastic moduli E_{f1} (top face) and E_{f2} (bottom face), subjected to an axisymmetric loading P applied through a central through-the-thickness insert.

For this case, the radial transverse shear stress resultant $Q_r(r)$, which maintains the equilibrium with the externally applied load P , can be expressed in the simple form:

$$Q_r(r) = \frac{P}{2\pi r}, \quad r \geq b_i \quad \text{[D.2-1]}$$

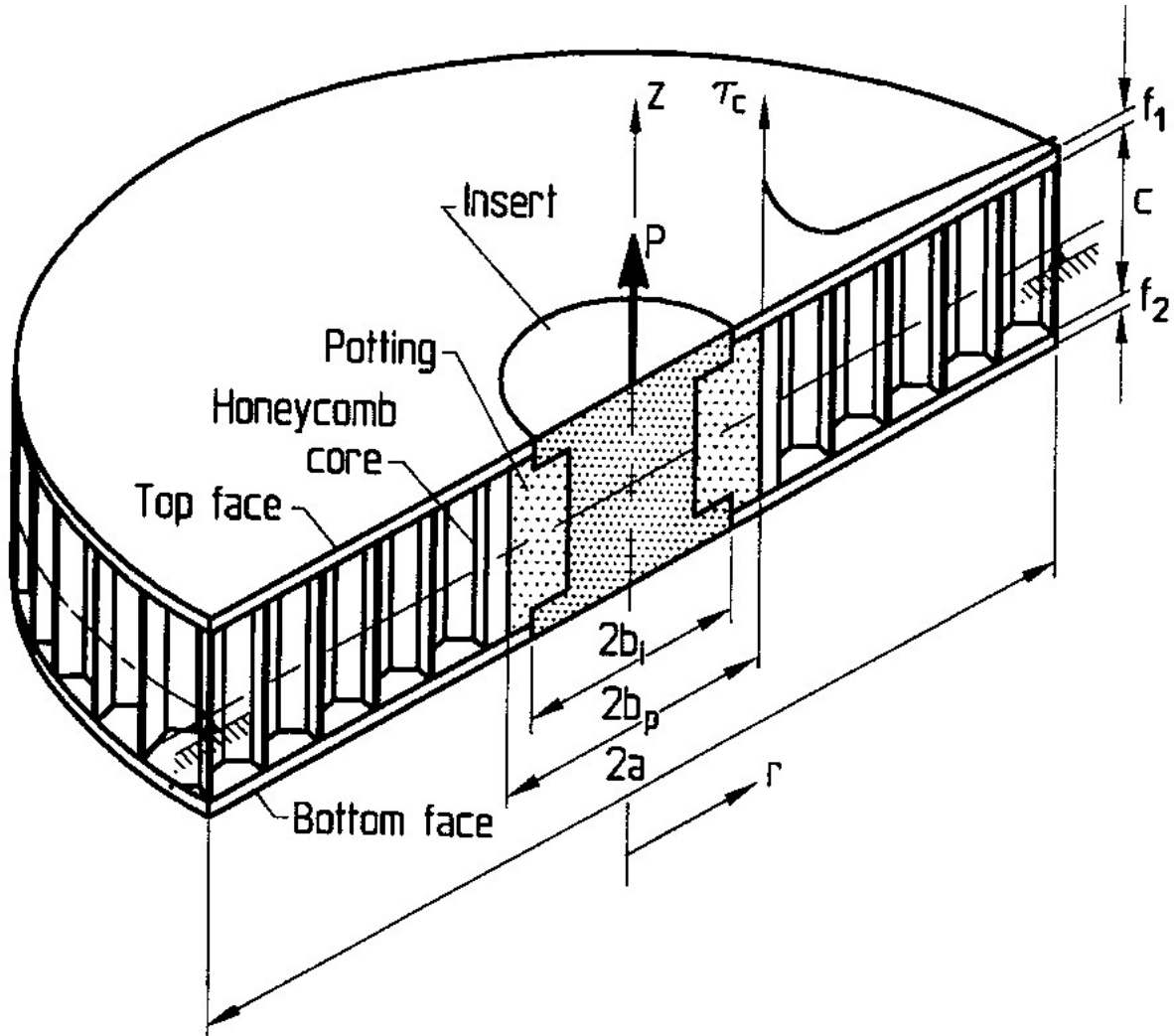

Figure D-1 Out-of-plane loading: Circular sandwich plate with through-the-thickness insert

Assuming that the elastic modulus of the core, i.e. potting and honeycomb, is much smaller than the elastic moduli of the face sheets, i.e. $E_c \ll E_{f1}, E_{f2}$ (effectively assuming the in-plane stiffness of the core to be $E_c \approx 0$, i.e. 'antiplane' core), the core shear stress is nearly constant over the height of the core, and the face sheet shear stresses vary parabolically over the face sheet thicknesses.

The shear stresses in the core and in the face sheets can be calculated using the approximate expressions, where $r \geq b_i$, [See: Figure D-1].

$$\tau_c(r) = \frac{Q_r(r)}{D} \frac{E_{f1}f_1 E_{f2}f_2 d}{(E_{f1}f_1 + E_{f2}f_2)}$$

$$= \frac{P}{2\pi D} \frac{E_{f1}f_1 E_{f2}f_2 d}{(E_{f1}f_1 + E_{f2}f_2)}$$

$$\tau_{f1}(r, z) = \frac{Q_r(r)}{D} \frac{E_{f1}}{2} \left[\left((d-e) + \frac{f_1}{2} \right)^2 - z^2 \right]$$

[D.2-2]

$$= \frac{P}{2\pi D} \frac{E_{f1}}{2} \left[\left((d-e) + \frac{f_1}{2} \right)^2 - z^2 \right]$$

$$(d-e) - \frac{f_1}{2} \leq z \leq (d-e) + \frac{f_1}{2}$$

$$\tau_{f2}(r, z) = \frac{Q_r(r)}{D} \frac{E_{f2}}{2} \left[\left(e + \frac{f_2}{2} \right)^2 - z^2 \right]$$

$$= \frac{P}{2\pi D} \frac{E_{f2}}{2} \left[\left(e + \frac{f_2}{2} \right)^2 - z^2 \right]$$

$$-e - \frac{f_2}{2} \leq z \leq -e + \frac{f_2}{2}$$

where:

- $\tau_c(r)$ = core (potting compound and honeycomb core) shear stress.
- $\tau_1(r, z)$ = shear stress in top face sheet.
- $\tau_2(r, z)$ = shear stress in bottom face sheet.
- z = thickness coordinate measured from the 'neutral surface' of the core.
- c = core thickness.
- d = $d = f_1/2 + c + f_2/2$; distance between the face sheet middle surfaces.
- e = $e = E_{f1}f_1 d / (E_{f1}f_1 + E_{f2}f_2)$; distance from 'neutral surface' of the core to the middle surface of the bottom face sheet.
- f_1 = thicknesses of top face sheet.
- f_2 = thicknesses of bottom face sheet.
- E_{f1} = elastic moduli of top face sheet.
- E_{f2} = elastic moduli of bottom face sheet.

For $E_c \ll E_{f1}, E_{f2}$, the sandwich plate stiffness D (Eqn. [D.2-2]) can be approximated by:

$$D \approx \frac{E_{f1} f_1^3}{12(1-\nu_{f1}^2)} + \frac{E_{f2} f_2^3}{12(1-\nu_{f2}^2)} + \frac{E_{f1} f_1 E_{f2} f_2 d^2}{E_{f1} f_1 + E_{f2} f_2} \quad [\text{D.2-3}]$$

where:

$$\nu_{f1}, \nu_{f2} = \text{Poisson's ratios of the face sheet materials.}$$

Assuming further that the thickness of the core is much larger than the thickness of the face sheets, i.e. $c \gg f_1, f_2$, the two first terms in the expression for D in (Eqn. [D.2-3]) vanish, and the approximate expressions for the core and face sheet shear stresses are found (again where $r \geq b_i$) by:

$$\tau_c(r) = \frac{Q_r(r)}{d} = \frac{P}{2\pi r d}$$

$$\tau_{f1}(r, z) = \frac{P}{2\pi r D} \frac{1}{f_1} \left[\left((d-e) + \frac{f_1}{2} \right) - z \right]$$

$$(d-e) - \frac{f_1}{2} \leq z \leq (d-e) + \frac{f_1}{2}$$

$$\tau_{f2}(r, z) = \frac{P}{2\pi r D} \frac{1}{f_2} \left[\left(e + \frac{f_2}{2} \right) + z \right]$$

$$-e - \frac{f_2}{2} \leq z \leq -e + \frac{f_2}{2} \quad [\text{D.2-4}]$$

From (Eqn. [D.2-4]), it is seen that:

- τ_c is constant over the height of the core, and
- τ_{f1}, τ_{f2} approximately varies linearly over the thickness of the face sheets.
- external load, P is carried primarily by the core material, and
- τ_c is proportional to $1/r$, i.e.:
 - τ_c displays a hyperbolic dependency of the radial coordinate r , [See: Figure D-1].

The approximations imposed in the derivation of (Eqn. [D.2-4]), i.e. that $E_c \ll E_f$ and $c \gg f_1, f_2$, are nearly always fulfilled for sandwich panels for space applications.

The results obtained using (Eqn. [D.2-4]) are therefore sufficiently accurate for design purposes.

D.3 Fully potted inserts

For sandwich plates with inserts of the fully potted or through-the-thickness types, [See: Figure D-1], failure usually occurs in the honeycomb core next to the potting-to-honeycomb interface ($r=b_p$), where the core shear stress in the honeycomb reach a maximum $\tau_{c,max}$ [[29-19], [29-20]].

[See also: Clause 8 for basic mechanics of sandwich structures]

NOTE Shear stresses in the potting compound are larger than in the honeycomb core, [See: D.2; Eqn. [D.2-4]], but as the potting compound displays much higher shear strength than the honeycomb, failure usually occurs in the honeycomb core.

At this location, the core shear stress can be calculated using the first part of (Eqn. [D.2-4]). The result obtained is:

$$\tau_{c\max} = \tau_c(r = b_p) = \frac{P}{2\pi b_p d} = \frac{P}{2\pi b_p d} \quad [D.3-1]$$

Failure occurs when $\tau_{c\max}$ reaches the core shear strength $\tau_{c\text{crit}}$ and the static load-carrying capability P_{crit} can be estimated by:

$$P_{\text{crit}} = 2\pi b_p d \tau_{\text{crit}} \quad [D.3-2]$$

NOTE (Eqn. [D.3-2]) is valid for both tensile and compressive out-of-plane loading, P .

D.4 Partially potted inserts

A partially potted insert, i.e. $c > h_p$ subjected to an out-of-plane load P_p is shown in Figure D-2.

For this case, the core underneath the potting is subjected to tensile or compressive stresses.

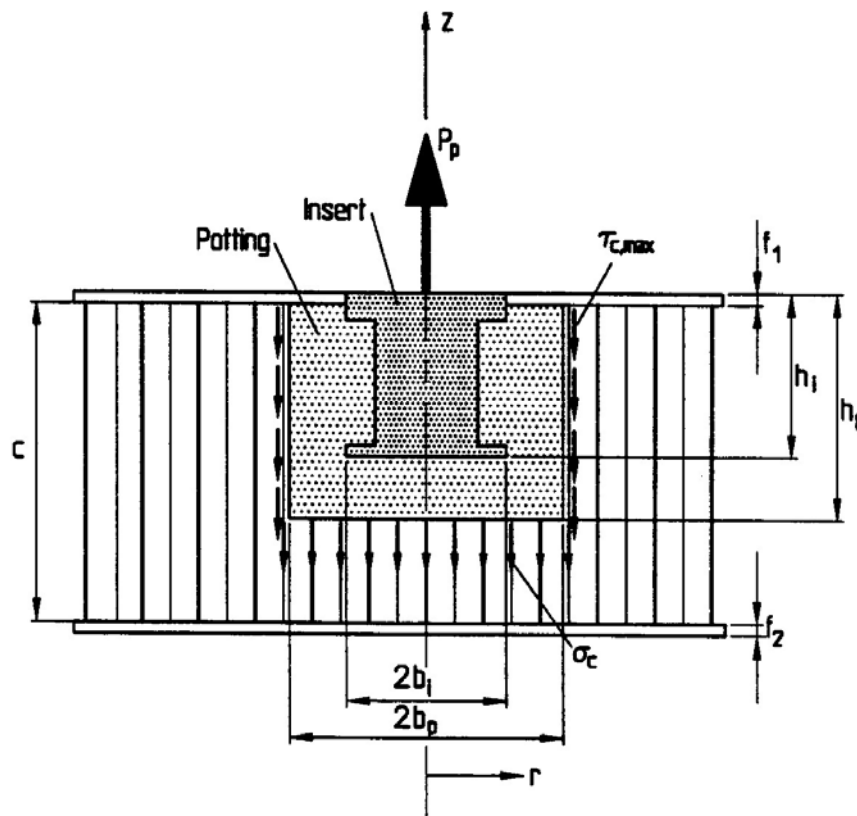

NOTE Load P , where subscript 'p' refers to a partially potted insert.

Figure D-2: Partially potted insert: out-of-plane loading

D.4.2 Aluminium honeycomb core

For aluminium cores, the tensile stresses underneath the potting increase for constant h_p with increasing core height c , or rather with increasing d ($d=f_1/2+c+f_2/2$ increases with increasing core height, c).

However, up to a certain value of d , failure still occurs due to shear rupture of the core next to the potting, and the static load carrying capability P_{crit} still increases linearly with d ; as predicted in by (Eqn. [D.3-2]), [See: D.3].

Although partially potted, the insert exhibits the same behaviour as that of a fully potted or 'through-the-thickness' insert, [29-19]; [29-20].

If $(c-h_p)$ attains a certain limit, [See: Figure D.04.1], the tensile or compressive stress underneath the potting reaches the tensile or compressive strength of the core, $\sigma_{c\ crit\ t}/\sigma_{c\ crit\ cr}$; [See: 6.6 and 6.7].

For larger core heights, shear rupture of the honeycomb around the potting and tensile or compressive failure of the core underneath the insert occur simultaneously, [29-19]; [29-20].

Thus, the static load-carrying capability is simultaneously limited by $\tau_{c\ crit}$ and $\sigma_{c\ crit\ t}$ or $\sigma_{c\ crit\ cr}$ and is practically independent of further increase in core height.

The out-of-plane load P_p applied to the insert-sandwich plate system can be divided into three contributing parts, [See: Figure D-2]:

$$P_p = P_f + P_s + P_n \quad [D.4-1]$$

where:

P_f Load part carried by the upper face sheet.

NOTE It is assumed that the upper and lower face sheets, despite the possible differences in material properties and thicknesses, carry loads of equal magnitude.

P_s Load part carried by shear stresses in the core around the potting.

P_n Load part carried by normal stresses in the honeycomb core underneath the potting material.

NOTE P_f is usually quite small, compared with P_s , for $f_1, f_2 \ll c$, as predicted by (Eqn. [D.2-4]); [See: D.2]

The contributing load parts P_f , P_s and P_n can be estimated by the expressions:

$$P_f = \frac{(P_{\tau_{c\ max}} - 2\pi b_p c \tau_{c\ max})}{2} \quad [D.4-2]$$

$$P_s = 2\pi b_p h_p \tau_{c\ max} \quad [D.4-3]$$

$$P_n = \pi b_p^2 \sigma_c \quad [D.4-4]$$

where:

$$P_{\tau_{c\ max}} = 2\pi b_p d \tau_{c\ max}$$

Load carried by fully potted insert, corresponding to $\tau_{c\ max}$.

$P_{\tau_{c \max}}$ becomes P_{crit} for $\tau_{c \max} = \tau_{c \text{crit}}$ according to (Eqn. [D.3-2]).

σ_c Normal stress in the honeycomb core underneath the potting, which is assumed to be uniform over the area of the potting compound (πb_p^2).

NOTE σ_{ct} for tensile normal stresses.
 σ_{cc} for compressive normal stresses.

h_p Potting height.

For an insert with height h_i [See: Figure D-2], the minimum potting height $h_{p \min}$ needed can be specified by the empirical result [29-19]; [29-20]:

$$h_{p \min} = h_i + 7 \text{ mm (whatever the core height } c) \quad [\text{D.4-5}]$$

Empirically, it has been found that the typical value of h_p depends on the core height c , according to, [29-19]; [29-20]:

$$h_{p \text{typ}} = h_{p \min} + A \tanh \left(\frac{c - h_{p \min}}{h_{p \min}} \right) \quad [\text{D.4-6}]$$

where:

$A = 5$ for honeycomb cell size $S_c = 4.8 \text{ mm (3/16" core)}$

$A = 2.5$ for honeycomb cell size $S_c = 3.2 \text{ mm (1/8" core)}$

NOTE (Eqn. [D.4-6]) is valid for partial potting only, i.e. for $c > h_i + 7 \text{ mm}$, [29-19]; [29-20].

Furthermore:

NOTE P_s is limited by the core shear strength $\tau_{c \text{crit}}$.

P_n is limited by either:

- core tensile strength $\sigma_{c \text{crit } t}$, or
- core compressive strength $\sigma_{c \text{crit } c}$.

Theoretically, the two failure modes do not occur simultaneously, i.e.

- Shear rupture, and
- Tensile or compressive core rupture.

In reality, the shear strength and the tensile or compressive strength of the core are reached (almost) simultaneously due to non-linear effects, [29-19]; [29-20].

Thus, the load components of the critical load, $P_{p \text{crit}}$ for a partially potted insert in a sandwich plate can be expressed as:

$$P_{f \text{crit}} = \frac{(P_{crit} - 2\pi b_p c \tau_{c \text{crit}})}{2} \quad [\text{D.4-7}]$$

$$P_{s \text{crit}} = 2\pi b_p h_p \tau_{c \text{crit}} \quad [\text{D.4-8}]$$

$$P_{n \text{crit}} = \pi b_p^2 \sigma_{c \text{crit}} \quad [\text{D.4-9}]$$

where:

$$\sigma_{crit} = \begin{cases} \sigma_{ccritt} & \text{for tensile loading} \\ \sigma_{ccritc} & \text{for compressive loading} \end{cases} \quad [D.4-10]$$

Using (Eqns. [D.4-7] to [D.4-9]), the static load-carrying capability P_{pcrit} for a partially potted insert in a large sandwich plate can be written as:

$$P_{pcrit} = \frac{P_{crit}}{2} + \pi b_p (2h_p - c) \tau_{ccrit} + \pi b_p^2 \sigma_{ccrit} \quad [D.4-11]$$

P_{crit} which represents the static load-carrying capability of a fully potted (through-the-thickness) insert in a large sandwich plate, is given by (Eqn. [D.3-2]).

D.4.3 Non-metallic honeycomb cores

For a non-metallic core, e.g. Nomex[®] or GFRP, the static load-carrying capability for constant h_p [See: Figure D-2], increases only slightly with increasing core height c (or rather with increasing $d=f_1/2+c+f_2/2$).

The reason for this is that rigid non-metallic cores cannot adequately redistribute stress concentrations by means of local deformations, [29-19]; [29-20].

An approximate relation can be used to estimate the permissible load on a partially potted insert in a sandwich plate with non-metallic core, using, [29-19]; [29-20]:

$$P_{pnon-metallic} = \frac{P_{crit}}{K_{tpp}} \quad [D.4-12]$$

where:

P_{crit} Static load-carrying capability of a fully potted (through-the-thickness) insert, where P_{crit} is given by (Eqn.[D.3-2]).

K_{tpp} Empirical stress concentration factor for partial potting, [29-19]; [29-20], where:

$$K_{tpp} = \left(\frac{h_p}{c} \right)^{0.62} \quad [D.4-13]$$

(Eqn. D.04.12) provides a conservative estimate of the static load-carrying capability of a partially potted insert in a sandwich plate with non-metallic core, [29-19]; [29-20].

For $c > 2.5h_p$, the permissible load, i.e. the static load-carrying capability, of a partially potted insert in a sandwich plate with non-metallic core does not increase any further with increasing core thickness, [29-19]; [29-20].

D.5 Potting failure

The potting underneath a partially potted insert loaded in out-of-plane tension is subjected to tensile stresses.

For a given insert height h_i and a given potting height h_p [See: Figure D-2], these tensile potting stresses increase with increasing core thickness, c .

For a certain core thickness, the tensile potting stresses, which are assumed to be uniformly distributed underneath the insert, can exceed the tensile strength $\sigma_{R\text{ crit}}$ of the potting resin before the tensile strength of the honeycomb $\sigma_{c\text{ crit}}$ underneath the potting is reached. This is the case for high-density honeycomb cores, and may also occur for fully potted inserts, [29-19]; [29-20].

A further increase of core thickness c results in a slight decrease of the insert load-bearing capability P_{crit} because P_{crit} for this specific failure mode is determined by $\sigma_{R\text{ crit}}$.

Owing to the relatively high rigidity of the potting compared with the honeycomb (the potting material is usually 5 to 10 times stiffer than the honeycomb), no advantage can be taken from the core shear strength, because the core shear stresses around the potting decrease with increasing core thickness c , [29-19]; [29-20].

D.5.1 Partially potted inserts

D.5.1.1 High-density aluminium core

As described in D.4, the external load applied to the insert-sandwich plate system can be divided into three parts:

NOTE Here the load is referred to as P_R , where 'R' denotes 'resin'.

$$P_R = P_f + P_{sR} + P_{nR} \quad [D.5-1]$$

where:

P_f Load part carried by the upper face-sheet.

P_{sR} Load part carried by shear stresses in the core around the potting over the height of the insert.

P_{nR} Load part carried by normal stresses in the potting resin underneath the insert.

NOTE P_f is usually quite small compared with P_{sR} [See: D.4].

The three contributing load parts P_f , P_{sR} and P_{nR} can be estimated by:

$$P_f = \frac{(P_{\tau_{c\text{max}}} - 2\pi b_p c \tau_{c\text{max}})}{2} \quad [D.4-2]$$

$$P_{sR} = 2\pi b_p h_i \tau_{c\text{max}} \quad [D.5-2]$$

$$P_{nR} = \pi b_R^2 \sigma_R \quad [D.5-3]$$

where:

σ_R Tensile stress in the potting resin, which is assumed to be uniform over the area of the potting compound (πb_R^2).

b_R Real potting radius, [See: 7.4].

h_i Insert height.

NOTE *b_R* is the radius of a circle with area equal to the real cross-sectional area of the potting.

b_p is the effective potting radius (analytical quantity that describes the radial influence zone of the potting resin).

[See also: 7.2 for potting dimensions]

P_{nR} can be rewritten in the form:

$$\begin{aligned} P_{nR} &= P_f + (P_R - 2P_f) \frac{c - h_i}{c} \\ &= P_f(1 - 2\psi) + P_R\psi \Rightarrow \end{aligned} \quad [D.5-4]$$

$$P_f = \frac{P_{nR}}{(1 - 2\psi)} - P_R \frac{\psi}{(1 - 2\psi)} \quad [D.5-5]$$

where:

$$\psi = \frac{c - h_i}{c} \quad [D.5-6]$$

P_{sR} can be expressed in terms of *P_R* using (Eqn. [D.3-1]):

$$P_R = 2\pi b_p d \tau_{c\max} \Rightarrow 2\pi \tau_{c\max} = \frac{P_R}{b_p d} \quad [D.5-7]$$

Inserting (Eqn. [D.5-7]) into (Eqn. [D.5-2]) gives an expression for *P_{sR}* in terms of *P_R*:

$$P_{sR} = 2\pi b_p h_i \tau_{c\max} \Rightarrow P_{sR} = P_R \frac{h_i}{d} \quad [D.5-8]$$

Introducing (Eqn. [D.5-5]) and (Eqn. [D.5-8]) into (Eqn. [D.5-1]) gives the critical tensile load *P_{R crit}* under which the potting resin underneath the insert fails (expressed in terms of *P_{nR crit}*):

$$P_{Rcrit} = 2P_{nRcrit} \frac{\left(\frac{1 - \psi}{1 - 2\psi} \right)}{\left(\frac{1 - \psi}{1 - 2\psi} - \frac{h_i}{d} \right)} \quad [D.5-9]$$

where:

$$P_{nRcrit} = \pi b_R^2 \sigma_{Rcrit} \quad [D.5-10]$$

and:

σ_{R crit} = Tensile strength of potting resin.

D.5.1.2 High-density non-metallic core

In D.4, a partially potted insert in a non-metallic honeycomb core is described, e.g. Nomex® or GFRP. A conservative estimate of the static load-carrying capability $P_{p \text{ non-metallic}}$ of such an insert is given in (Eqn. [D.4-12]) and (Eqn. [D.4-13]), [29-19]; [29-20].

Potting failure underneath the insert in a non-metallic core is considered to occur when:

$$P_{R \text{ non-metallic}} = \pi b_R^2 \sigma_{R \text{ crit}} \quad [\text{D.5-11}]$$

Where:

- b_R = Real potting radius, [See: 7.4].
- $\sigma_{R \text{ crit}}$ = Tensile strength of potting resin.

D.6 Compressive load: Additional criteria

D.6.1 Introduction

The upper face sheet does not contribute to the load-carrying capability under compressive out-of-plane load, if the thickness of the (aluminium) face sheet exceeds 0.6 mm, [29-19]; [29-20].

The reason for this is that tensile rupture of the bond between the core and the upper face sheet adjacent to the insert is induced.

Thus, in estimating the static load-carrying capability it is necessary to neglect the load-carrying contribution of the upper face sheet, [29-19]; [29-20].

NOTE This applies to inserts in sandwich plates with thick face sheets subjected to compressive out-of-plane loading.

D.6.2 Aluminium core

D.6.2.1 Fully potted insert

In view of the comment in D.6.1 for a fully potted insert in an aluminium core, the static load-carrying capability is 'reduced' to:

$$P_{crit} = P_{f \text{ crit}} + P_{s \text{ crit}}$$

$$= \frac{(P_{crit} - 2\pi b_p c \tau_{ccrit})}{2} + 2\pi b_p c \tau_{ccrit} \Rightarrow$$

$$P_{crit} = \frac{P_{crit}}{2} + \pi b_p c \tau_{ccrit} \quad [\text{D.6-1}]$$

where:

$P_{f \text{ crit}}$ and $P_{s \text{ crit}}$ (with 'full' core height) are introduced according to (Eqn. [D.4-7]) and (Eqn. [D.4-8]).

P_{crit} is given by (Eqn. [D.3-2]).

D.6.2.2 Partially potted insert

In a similar manner, the static load-carrying capability for a partially potted insert is 'reduced' to:

$$\begin{aligned}
 P_{p\text{critc}} &= P_{s\text{crit}} + P_{n\text{crit}} \Rightarrow \\
 P_{p\text{critc}} &= 2\pi b_p h_p \tau_{c\text{crit}} + \pi b_p^2 \sigma_{c\text{crit}}
 \end{aligned}
 \tag{D.6-2}$$

where:

$P_{s\text{crit}}$ and $P_{n\text{crit}}$ are from (Eqn.[D.4-8]) and (Eqn. [D.4-9]).

D.6.3 Non-metallic core

D.6.3.1 Fully potted insert

The static load-carrying capability can be estimated according to (Eqn. [D.6-1]), [29-19]; [29-20].

D.6.3.2 Partially potted insert

The static load-carrying capability is reduced to, [29-19]; [29-20]:

$$P_{\text{critc}} = \left(\frac{P_{\text{crit}}}{2} + \pi b_p c \tau_{c\text{crit}} \right) \frac{1}{K_{tpp}}
 \tag{D.6-3}$$

Where:

K_{tpp} Stress concentration factor for partial potting; as given by (Eqn. [D.4-13]).

D.7 Reliability considerations

D.7.1 Correlation coefficient

Comparison of the theoretical with test results, [29-19]; [29-20], gives the correlation coefficient, CC :

$$CC = \frac{P_{\text{crit test}}}{P_{\text{crit theory}}}
 \tag{D.7-1}$$

Table D-1 gives CC values for the various insert configurations. The correlation between test results and theory is very good for:

- Fully potted inserts under tensile and compressive loading;
- Partially potted inserts under compressive loading.

However, the correlation with respect partially potted inserts under tensile loading is considerably less favourable, as seen by the standard deviation on the comparative results, [See: Table D-1].

Table D-1: Correlation coefficients

Insert	Load	Correlation coefficient (CC)	Standard deviation (G)
Fully potted ⁽¹⁾	Tensile	0.993	0.059
	Compressive		
Partially potted	Tensile	1.043	0.52
	Compressive	0.998	0.072

NOTE (1) Including 'through-the-thickness' and inserts behaving like fully potted inserts, [See also: D.1 for determining potting].

D.7.2 Reliability coefficient

To ensure a reliability of 99%, the theoretically-predicted static load-carrying capabilities are multiplied by the reliability coefficient *RC*, as given in Table D-2, [29-19]; [29-20].

Table D-2: Reliability coefficients

Out-of-plane loading	Core		Reliability coefficient (RC)	
			Minimum value ⁽²⁾	Average value ⁽³⁾
	Tensile ⁽¹⁾	Aluminium, perforated	$RC = 1.172 - 0.0063 c - 0.2641 f$ [D.7-2]	$RC = 1.207 - 0.00544 c - 0.2088 f$ [D.7-3]
Others ⁽⁴⁾		$RC = 0.91$ [D.7-4]	$RC = 1.00$ [D.7-5]	
Compressive	Aluminium, perforated	$RC = 0.89$ [D.7-6]	$RC = 1.00$ [D.7-7]	
	Others ⁽⁴⁾			

NOTE (1) Assuming face sheets of identical thickness, i.e. $f_1=f_2=f$.
 NOTE (2) Exceeded by a probability of 90%
 NOTE (3) Exceeded by a probability of 50%
 NOTE (4) e.g. unperforated aluminium, Nomex[®] and GFRP.

D.7.2.2 Non-metallic cores

The analytically-predicted, static load-carrying capabilities of partially potted inserts in non-metallic cores have been subject to far less testing than those in metallic cores, [29-19]; [29-20].

Therefore, the predicted strengths of partially potted inserts in non-metallic cores are only to be used with caution, and preferably for preliminary design purposes only.

[See also: 12.3 for minimum and average values; 12.4 for safety factors]

D.8 Design graphs

The set of design graphs, presented in B.2, are based on the analytical expressions for, [See also: B.1]:

- Predicting static load-carrying capability of inserts subjected to out-of-plane loading, [See: D.1].
- Reliability coefficients RC , [See: D.7; Table D-2]

D.8.1 Static load-carrying capability

The design graphs provide the static load-carrying capability P_{ss} of inserts in large sandwich plates subjected to tensile or compressive out-of-plane loading, where the static load-carrying capability P_{ss} is:

$$P_{ss} = RC \quad \left\{ \begin{array}{l} P_{crit} \text{ for through-the thickness and fully potted inserts} \\ P_{pcrit} \text{ for partially potted inserts} \end{array} \right. \quad [\text{D.8-1}]$$

Where:

P_{crit} and $P_{p crit}$ are determined according to D.1.

D.8.1.2 Core types

For different core types, P_{ss} is plotted as a function of the:

- Core thickness, c ;
- Face sheet thickness, f ;
- Insert diameter, $d_i = 2b_i$.

NOTE Only sandwich configurations with face sheets of identical thickness are included, i.e. ($f_1=f_2=f$).

D.8.1.3 Insert height

The insert capability design graphs have been established for a fixed insert height $h_i = 9$ mm. Although, they are also applicable for other h_i -values.

A modification of h_i shifts the 'break' in the curves towards lower or higher c -values according to, [29-19]; [29-20]:

$$C'^* = C' + h_i^* - h_i \quad [\text{D.8-2}]$$

where:

- h_i 'Basic' insert height, i.e. $h_i = 9$ mm.
- h_i^* 'New' insert height.
- C' Core height at 'curve break' for basic insert height h_i .
- C'^* 'New' c -value at 'curve break' corresponding to the 'new' insert height h_i^* .

NOTE The 'curve break' in the design graph signifies a change of failure mode from either:

- core shear to core failure underneath the potting, or
- core shear to potting failure underneath the insert.

[See also: D.4; D.5 and 12.6 for more information on this failure mode change]

An increase in h_i (from $h_i = 9$ mm in the design graphs) increases the static load-carrying capability P_{ss} for those cases where failure occurs in the:

- Core underneath the potting, or
- Potting underneath the insert.

NOTE An increase in h_i is especially advised if a potting failure underneath the insert is expected.

D.8.1.4 Average and minimum values

P_{ss} average and minimum values are given on design graphs, where:

- Average values: P_{ss} and $P_{ss\ av}$ are based on average properties (exceeded by a probability of 50%) of the:
 - core shear strength;
 - potting dimensions;
 - model correlation coefficient, RC .
- Minimum ('lower bound') values: P_{ss} and $P_{ss\ min}$ can be regarded as design A-values ($P = 99\%$; $CL = 95\%$) for all cases where:
 - incoming inspection is performed, [See: 26.1];
 - mounting of the inserts: in accordance with manufacturing, [See: 23.1] and QA procedures, [See: 28.1].

NOTE See also: 12.3 for further details on average and minimum values of P_{ss} .

D.9 Other external loads

The theoretical treatment of sandwich plates with inserts in Annex D is based on classical 'antiplane' sandwich theory, [[29-15], [29-16], [29-17], [29-18]], i.e. the simplest possible sandwich plate theory, extended with the assumption that the correct location for the peak shear stress is at the potting-to-honeycomb interface, i.e. $r = b_p$.

[See also: Section 8 for the mechanics of sandwich structures]

The derived equations give a sensible approximation for the case of sandwich plates with inserts subjected to out-of-plane loading.

NOTE The validity of the equations is independent of the boundary conditions specified along the outer radius of the considered sandwich plate, provided that the sandwich plate radius is large enough.

Usually, the results obtained are of sufficient accuracy if the radius of the analysed sandwich plate is twice the potting radius, i.e. if $a > 2b_p$, [29-19]; [29-20].

D.9.1 Non-axisymmetric and twisting loads

Classical 'antiplane' sandwich theory cannot be used for predicting either the load response or the static load-carrying capability for more complicated loading cases, i.e. cases of sandwich panels with inserts subjected to:

- Non-axisymmetric loads, such as in-plane or bending moments;
- Twisting loads.

For such cases it is necessary to adopt more refined modelling. This can be done by elaborate finite element modelling, which is very costly, or alternatively by use of a 'higher-order' sandwich plate theory.

D.9.1.1 'Higher-order' theory

'Higher-order' sandwich plate theory has been specially developed and adapted for analysing sandwich plates with 'hard points' in the form of inserts, [29-21][29-22][29-24].

Unfortunately, the application of the 'higher-order' sandwich plate theory is rather complicated due to the mathematical complexity of the theory, [See also: 8.5].

To provide design engineers and stress analysts with access to the analysis model, modules for the analysis of sandwich plates with 'through-the-thickness', 'fully potted' and 'partially potted' inserts under general load conditions, could be added to the software package ESAComp[®].

NOTE ESAComp[®] is a software package for the analysis and design of composite laminates and structural elements, developed for the European Space Agency and available from Compoengineering Inc., [29-23]; [29-25].

D.10 References

D.10.1 General

- [29-14] O. T. Thomsen - CompConsult; 'Estimation of the load-carrying capability of an insert in a large sandwich panel'; ESTEC Contract No. 10.983/94/NL/PP Work Order No. 6 (March 1996)
- [29-15] Plantema, F. J. 'Sandwich Construction' John Wiley & Sons, New York, USA, 1966
- [29-16] Allen, H. G. 'Analysis and Design of Structural Sandwich Panels' Pergamon Press, Oxford, UK, 1969
- [29-17] Stamm, K. and Witte, H. 'Sandwichkonstruktionen' (in German); Springer-Verlag, Wien, Austria, 1974
- [29-18] Zenkert, D. 'An Introduction to Sandwich Construction' EMAS Publishing, West Midlands, UK, 1995
- [29-19] W. Hertel, W. Paul and D. Wagner- ERNO Raumfahrttechnik GmbH, Structures Department, Bremen, Germany. 'Standardisation Programme for Design and Testing of Inserts'; ESA CR (P) 1498. ESA Contract No. 3442/77/NL/PP (1981)

- [29-20] W. Paul and D. Wagner - ERNO Raumfahrttechnik GmbH, Structures Department, Bremen, Germany. 'Standardisation Programme for Design and Testing of Inserts, Rider II'; ESA CR (P) 1665. ESA Contract No. 3442/77/NL/PP) (1981)
- [29-21] Thomsen, O. T. 'Analysis of Sandwich Plates with Through-the-Thickness Inserts Using a Higher-Order Sandwich Plate Theory' ESA/ESTEC Report EWP-1807 (1994)
- [29-22] Thomsen, O. T. 'Analysis of Sandwich Plates with Fully Potted Inserts Using a Higher-Order Sandwich Plate Theory'; ESA/ESTEC Report EWP-1827 (1995)
- [29-23] Saarela, O., Palanterä M., Häberle, J. and Klein, M. 'ESACOMP: A Powerful Tool for the Analysis and Design of Composite Materials'; Proceedings of the International Symposium on Advanced Materials for Lightweight Structures (ESA-WPP-070), ESTEC, Noordwijk, (March 1994), p. 161-169
- [29-24] Section 8- References for more recent work on sandwich plate mechanics by O.T. Thomsen, Aalborg University, DK.
- [29-25] M. Palanterä: Componeering Inc, Finland
ESAComp® - private communication (2004)

Annex E

IATP

E.1 Introduction

A summary is presented of test data generated under the ESTEC-funded IATP insert allowable test programme, conducted between 1995 and 1997.

The aim of the programme was to provide input for an ESTEC evaluation of the reliability coefficient, *RC* for selected CFRP sandwich panel constructions and insert configurations, [29-26]; [29-27].

The summary describes:

- Materials, [See: E.2];
- Testing, [See: E.3];
- Data, [See: E.4].

NOTE No analysis of the reliability coefficient, *RC* is given.

E.2 Materials

Table E-1 lists the various materials used in IATP-2, [29-27].

NOTE IATP-2 used fully qualified materials for the ENVISAT Polar Platform Program.

Table E-1: IATP: Materials

Item	Type	Specification
Fabric	VICOTEX FIBREDUX 914/34%/G829 NOTE: Contains M40 and T300 carbon fibres.	Fibre: 60% \pm 2% Resin: 69% \pm 3% Voids: <2% Areal weight (g/m ²): pregreg: 295 \pm 15% dry fabric: 195 \pm 8% Volatile: \leq 2% (weight) ILSS: 40 N/mm ² (min) 45 N/mm ² (average) 4-POINT FLEXURAL Strength: 480 MPa (min) 600 MPa (average) Stiffness: 155 GPa (min) 160 GPa (average)
Honeycomb	HEXCEL CR III 5056-3/16-.0015 Perf. Thickness 45 mm Perf. Thickness 80 mm	Compressive strength: Stabilised: 3.38 MN/m ² (min) [490 psi] Density: 70.48 kg/m ³ [4.4 lb/ft ³]
Film adhesive	REDUX 319L	-
Primer	REDUX 109	-
Potting compound	STYCAST 1090/Catalyst 9	Compressive strength (average): 73 MPa
Inserts ⁽¹⁾	Standard Equipment Unit Insert: Type E M6	Single side insert. Dia.: 17.5 mm; Length: 15 mm
	Type F F6	Through spool Dia.: 21.3 mm; Length = panel thickness
NOTE ⁽¹⁾ As defined in PPF MMS.		

E.3 Testing

IATP used 'in-house' test methods. Figure E-1 shows the test jig for:

- shear testing, [29-26];
- pull-out testing: test speed 1.5 mm/min, [29-26]; [29-27].

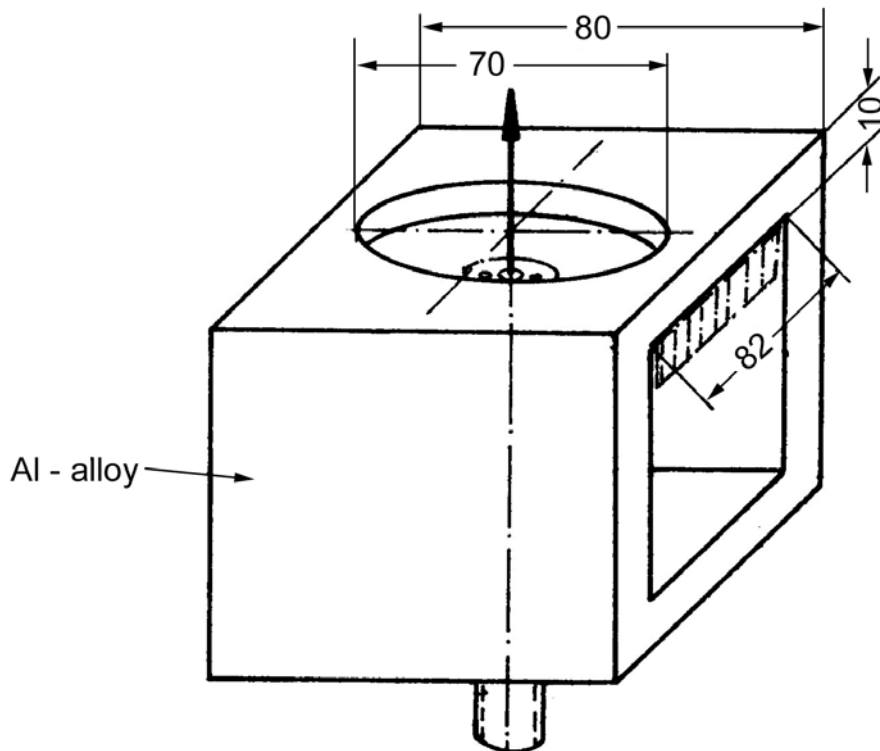

Figure E-1: Manufacture control: Insert tensile pull-out test fixture

[See also: 27.3 for text fixtures and sample sizes]

E.3.2 Shear test configurations

Table E-2 shows the various insert-sandwich panel configurations covered in IATP-1.

[See also: E.2 for materials; E.4; Table E-4 for test data]



Table E-2: IATP: Shear test panel configurations

IATP/Case	Core Height (mm) ⁽¹⁾	Skin		Insert	
		Thickness (mm)	Lay-up	Type	Dia. (mm)
1/7	20	1.08	(0, +60, -60)s	Type F2 thru'spool	21.3
1/8	20	1.08	(0, +60, -60)s	Type E M6	17.5
1/9	20	1.08	(0, +60, -60)s	Type F3 thru'spool	21.3
1/13	20 (2)	2.47	not stated	Type F4 thru'spool	25 / 17.5
1/11	20 (2)	4.32	not stated	Type F3 thru'spool	21.3
1/15	20 (2)	4.94	not stated	Type F5 thru'spool	25 / 17.5
1/3	45	1.08	(0, +60, -60)s	Type E M6	17.5
1/1	45	2.16	(0, +60, -60)s × 2	Type 30 mm counterbore	17.5
1/16	45	3.24	Fabric only: (0, +60, -60)s × 3	Type E M6	17.5
1/17	45	3.24	Fabric only: (0, +60, -60)s × 3	Type F3 thru'spool	21.3
1/4	45	4.86	Fabric only: (0, +60, -60)s × 4, (0,+60,-60)	Type E M6	17.5
1/5	45	4.86	Fabric only: (0, +60, -60)s × 4, (0,+60,-60)	Type F1 thru'spool	21.3
NOTE (1)	Aluminium 5056 P Type 3/16-0.0015				
NOTE (2)	Aluminium 5056 P Type 1/8-0.002				

E.3.3 Pull-out test configurations

Table E-3 shows the various insert-sandwich panel configurations covered in IATP-1 and -2.

[See: E.2 for materials; E.4; Table E-5 for test data]



Table E-3: IATP: Pull-out test panel configurations

IATP/Case	Core Height (mm) ⁽¹⁾	Skin		Insert	
		Thickness (mm)	Lay-up	Type	Dia. (mm)
1/6	20	1.08	(0, +60, -60)s	Type F2 thru'spool	21.3
1/12	20 ⁽²⁾	2.47	not stated	Type F4 thru'spool	25 / 17.5
1/10	20 ⁽²⁾	4.32	not stated	Type F3 thru'spool	21.3
1/14	20 ⁽²⁾	4.94	not stated	Type F4 thru'spool	25 / 17.5
1/2	45	1.08	(0, +60, -60)s	Type E M6	17.5
1/Envi ⁽³⁾	45	1.08	(0, +60, -60)s	Type F1 thru'spool	21.3
1/Envi ⁽³⁾	45	2.16	(0, +60, -60)s × 2	Type E M6	17.5
1/Envi ⁽³⁾	45	2.16	(0, +60, -60)s × 2	Type F2 thru'spool	21.3
2/5	45	4.86	Fabric only: (0, +60, -60)s × 4, (0,+60,-60)	Type E M6	17.5
2/6	45	4.86	Fabric only: (0, +60, -60)s × 4, (0,+60,-60)	Type F6 thru'spool	21.3
2/3	80	1.08	(0, +60, -60)s	Type E M6	17.5
2/4	80	1.08	(0, +60, -60)s	Type F6 thru'spool	21.3
2/1	80	4.86	Fabric only: (0, +60, -60)s × 4, (0,+60,-60)	Type E M6	17.5
2/2	80	4.86	Fabric only: (0, +60, -60)s × 4, (0,+60,-60)	Type F6 thru'spool	21.3
NOTE (1)	Aluminium 5056 P Type 3/16-0.0015				
NOTE (2)	Aluminium 5056 P Type 1/8-0.002				
NOTE (3)	From Kongsberg's ENVISAT validation. No data given in Table E-5.				

E.4 Test data

E.4.1 Shear test data

Table E-4 summarises shear test data, [29-26].

- 'In-house' test methods;
- Test speed: 0.5 mm/min, [29-26].



Table E-4: IATP: Shear test data

IATP/ Case	Core Height (mm) ⁽¹⁾	Skin		Insert		Shear Load Test Data (N) ⁽⁴⁾		
		Thickness (mm)	Lay-up	Type	Dia. (mm)	R _m	Mean R _m	SD
1/7	20	1.08	(0, +60, -60)s	Type F2 thru'spool	21.3	12250 15875 16000 15400 17750	15455	2000
1/8	20	1.08	(0, +60, -60)s	Type E M6	17.5	8625 6575 6600 8250 8175	7645	980
1/9 ⁽⁵⁾	20	1.08	(0, +60, -60)s	Type F3 thru'spool	21.3	Def. load: 25200 22400 35200 28000 24000 Peak load: 46600 n/a 45200 49400 49100	Def. load: 26960 Peak load: 47575	Def. load: 5040 Peak load: 2021
1/13	20 ⁽²⁾	2.47	not stated	Type F4 thru'spool	25 / 17.5	36100 33900 32600 34000 34300	34180	1256
1/11 ⁽⁵⁾	20 ⁽²⁾	4.32	not stated	Type F3 thru'spool	21.3	Def. load: 27000 26000 25000 25400 24000 Peak load: 48200 49400 48600 49200 49000	Def. load: 25480 Peak load: 48880	Def. load: 1119 Peak load: 482
1/15 ⁽⁵⁾	20 ⁽²⁾	4.94	not stated	Type F5 thru'spool	25 / 17.5	Def. load: 29250 27400 30000 28000 31000 Peak load: 46500 42700 48700 46900 52200	Def. load: 29130 Peak load: 47400	Def. load: 1461 Peak load: 3460
1/3	45	1.08	(0, +60, -60)s	Type E M6	17.5	8250	8588	640



IATP/ Case	Core Height (mm) ⁽¹⁾	Skin		Insert		Shear Load Test Data (N) ⁽⁴⁾		
		Thickness (mm)	Lay-up	Type	Dia. (mm)	<i>R_m</i>	Mean <i>R_m</i>	SD
						9613 8425 7725 8925		
1/1	45	2.16	(0, +60, -60)s × 2	Type 30 mm counterbore M4 std.	17.5	13900 13125 13550 12300 14200 12725	13300	657
1/16	45	3.24	Fabric only: (0, +60, -60)s × 3	Type E M6	17.5	14250 13150 13750 15500 15850	14500	1148
1/17	45	3.24	Fabric only: (0, +60, -60)s × 3	Type F3 thru'spool	21.3	48800 51600 47900 47700 44600	48120	2244
1/4	45	4.86	Fabric only: (0, +60, -60)s × 4, (0,+60,-60)	Type E M6	17.5	14000 16550 14725 14250 14255	14750	1040
1/5 ⁽⁵⁾	45	4.86	Fabric only: (0, +60, -60)s × 4, (0,+60,-60)	Type F1 thru'spool	21.3	Def. load: n/a 44000 41750 38800 40000 Peak load: 80375 77750 61500 78125 76500	Def. load: 41138 Peak load: 74850	Def. load: 2260 Peak load: 7593

NOTE (1) Aluminium 5056 P Type 3/16-0.0015

NOTE (2) Aluminium 5056 P Type 1/8-0.002

NOTE (3) From Kongsberg's ENVISAT validation

NOTE (4) Deflection load: point where load deflection curve is no longer linear (*R_p*).

Peak load: Max. load + clipping of bolts.

NOTE (5) Greyed configurations **did not** meet calculated allowable, [29-26]



E.4.2 Pull-out test data

Table E-5 summarises pull-out test data, [29-26]; [29-27].

- 'In-house' test methods;
- Test speed 1.0 mm/min, [29-26].

Table E-5: IATP: Pull-out test data

IATP/ Case	Core Height (mm) ⁽¹⁾	Skin		Insert		Pull-out Test Data (N) ⁽⁴⁾		
		Thickness (mm)	Lay-up	Type	Dia. (mm)	Rm	Mean Rm	SD
1/6	20	1.08	(0, +60, -60)s	Type F2 thru'spool	21.3	6400 6375 6575 7025 6750	6625	270
1/12	20 ⁽²⁾	2.47	not stated	Type F4 thru'spool	25 / 17.5	16600 16925 17075 16900 16800	16860	176
1/10 ⁽⁵⁾	20 ⁽²⁾	4.32	not stated	Type F3 thru'spool	21.3	1st peak: 16000 n/a 18600 14300 17500 Peak: 17300 20800 21250 16900 19400	1st peak: 16600 Peak: 19130	1st peak: 1867 Peak: 1980
1/14	20 ⁽²⁾	4.94	not stated	Type F4 thru'spool	25 / 17.5	22250 ⁽⁴⁾ 30200 28600 29400 29400	29400	655
1/2	45	1.08	(0, +60, -60)s	Type E M6 Single sided	17.5	6580 5560 5970 5950 6390	6090	359
1/Envi ⁽³⁾	45	1.08	(0, +60, -60)s	Type F1 thru'spool	21.3	not stated		
1/Envi ⁽³⁾	45	2.16	(0, +60, -60)s × 2	Type E M6 Single sided	17.5	not stated		
1/Envi ⁽³⁾	45	2.16	(0, +60, -60)s × 2	Type F2 thru'spool	21.3	not stated		
2/5	45	4.86	Fabric only: (0, +60, -60)s × 4, (0,+60,-60)	Type E M6 Single sided	17.5	5650 6275 6450 5800 6100	6055	330
2/6	45	4.86	Fabric only: (0, +60, -60)s × 4, (0,+60,-60)	Type F6 thru'spool	21.3	16425 16350 16225 16125 16350	16295	330



IATP/ Case	Core Height (mm) ⁽¹⁾	Skin		Insert		Pull-out Test Data (N) ⁽⁴⁾		
		Thickness (mm)	Lay-up	Type	Dia. (mm)	<i>Rm</i>	Mean <i>Rm</i>	SD
2/3	80	1.08	(0, +60, -60)s	Type E M6 Single sided	17.5	7275 5850 6925 7050 4450	6310	1176
2/4	80	1.08	(0, +60, -60)s	Type F6 thru'spool	21.3	15550 11450 15100 11300 14950	13670	2107
2/1	80	4.86	Fabric only: (0, +60, -60)s × 4, (0,+60,-60)	Type E M6	17.5	6675 6575 8550 6300 6600	6940	911
2/2	80	4.86	Fabric only: (0, +60, -60)s × 4, (0,+60,-60)	Type F6 thru'spool	21.3	16800 16350 15625 16750 16200	16345	477

NOTE (1) Aluminium 5056 P Type 3/16-0.0015
 NOTE (2) Aluminium 5056 P Type 1/8-0.002
 NOTE (3) From Kongsberg's ENVISAT validation
 NOTE (4) Aluminium test-rig deformed during first test; early fracture of test sample. New steel test-rig used for remaining samples.
 NOTE (5) Greyed configurations **did not** meet calculated allowable, [29-26]



E.4.3 Design allowables

E.4.3.1 Shear test

Table E-6 compares IATP-1 shear test data with design allowables, [29-26], [29-28].

Table E-6: IATP: Shear test results versus design allowables

IATP/ Case	Core Height (mm) ⁽¹⁾	Skin		Insert		Shear Load Test Data (N) ⁽³⁾		
		Thickness (mm)	Lay-up	Type	Dia. (mm)	Mean <i>R_m</i>	SD	Design Allowable
1/7	20	1.08	(0, +60, -60)s	Type F2 thru'spool	21.3	15455	2000	10560
1/8	20	1.08	(0, +60, -60)s	Type E M6	17.5	7645	980	3816
1/9 ⁽⁴⁾	20	1.08	(0, +60, -60)s	Type F3 thru'spool	21.3	Def. load: 26960 Peak load: 47575	Def. load: 5040 Peak load: 2021	42224
1/13	20 ⁽²⁾	2.47	not stated	Type F4 thru'spool	25 / 17.5	34180	1256	25000
1/11 ⁽⁴⁾	20 ⁽²⁾	4.32	not stated	Type F3 thru'spool	21.3	Def. load: 25480 Peak load: 48880	Def. load: 1119 Peak load: 482	42224
1/15 ⁽⁴⁾	20 ⁽²⁾	4.94	not stated	Type F5 thru'spool	25 / 17.5	Def. load: 29130 Peak load: 47400	Def. load: 1461 Peak load: 3460	50000
1/3	45	1.08	(0, +60, -60)s	Type E M6	17.5	8588	640	3818
1/1	45	2.16	(0, +60, -60)s × 2	Type 30mm counter-bore M4 std.	17.5	13300	657	6311
1/16	45	3.24	Fabric only: (0, +60, -60)s × 3	Type E M6	17.5	14500	1148	8810
1/17	45	3.24	Fabric only: (0, +60, -60)s × 3	Type F3 thru'spool	21.3	48120	2244	31668
1/4	45	4.86	Fabric only: (0, +60, -60)s × 4, (0,+60,-60)	Type E M6	17.5	14750	1040	12553
1/5 ⁽⁴⁾	45	4.86	Fabric only: (0, +60, -60)s × 4, (0,+60,-60)	Type F1 thru'spool	21.3	Def. load: 41138 Peak load: 74850	Def. load: 2260 Peak load: 7593	48283
NOTE (1)	Aluminium 5056 P Type 3/16-0.0015							
NOTE (2)	Aluminium 5056 P Type 1/8-0.002							
NOTE (3)	Deflection load: point where load deflection curve is no longer linear (<i>R_p</i>). Peak load: Max. load + clipping of bolts.							
NOTE (4)	Greyed configurations did not meet calculated allowable, [29-26]							



E.4.3.2 Pull-out test

Table E-7 compares IATP-1 pull-out test data with design allowables, [29-26], [29-28].

Table E-7: IATP : Pull-out test results versus design allowables

IATP/ Case	Core Height (mm) ⁽¹⁾	Skin		Insert		Shear Load Test Data (N) ⁽³⁾		
		Thickness (mm)	Lay-up	Type	Dia. (mm)	Mean <i>R_m</i>	SD	Design Allowable
1/6	20	1.08	(0, +60, -60)s	Type F2 thru'spool	21.3	6625	270	3408
1/12	20 ⁽²⁾	2.47	not stated	Type F4 thru'spool	25 / 17.5	16860	176	6270
1/10 ⁽⁵⁾	20 ⁽²⁾	4.32	not stated	Type F3 thru'spool	21.3	1st peak: 16600 Peak: 19130	1st peak: 1867 Peak: 1980	20000
1/14	20 ⁽²⁾	4.94	not stated	Type F4 thru'spool	25 / 17.5	29400 ⁽⁴⁾	655	15100
1/2	45	1.08	(0, +60, -60)s	Type E M6 Single sided	17.5	6090	359	4770
2/5	45	4.86	Fabric only: (0, +60, -60)s × 4, (0,+60,-60)	Type E M6 Single sided	17.5	6055	330	not stated
2/6	45	4.86	Fabric only: (0, +60, -60)s × 4, (0,+60,-60)	Type F6 thru'spool	21.3	16295	330	not stated
2/3	80	1.08	(0, +60, -60)s	Type E M6 Single sided	17.5	6310	1176	not stated
2/4	80	1.08	(0, +60, -60)s	Type F6 thru'spool	21.3	13670	2107	not stated
2/1	80	4.86	Fabric only: (0, +60, -60)s × 4, (0,+60,-60)	Type E M6	17.5	6940	911	not stated
2/2	80	4.86	Fabric only: (0, +60, -60)s × 4, (0,+60,-60)	Type F6 thru'spool	21.3	16345	477	not stated
1/5	45	4.86	Fabric only: (0, +60, -60)s × 4, (0,+60,-60)	Type F1 thru'spool	21.3	Def. load: 41138 Peak load: 74850	Def. load: 2260 Peak load: 7593	48283
NOTE (1)	Aluminium 5056 P Type 3/16-0.0015							
NOTE (2)	Aluminium 5056 P Type 1/8-0.002							
NOTE (3)	No data from Kongsberg's ENVISAT validation stated, [29-27].							
NOTE (4)	Aluminium test-rig deformed during first test; early fracture of test sample. New steel test-rig used for remaining samples.							
NOTE (5)	Greyed configurations did not meet calculated allowable, [29-26]							

E.4.4 General comments on IATP-2 pull-out test data

Although no detailed analysis of test data was made in IATP-2, a number of general comments were provided, [29-27].

Load-deflection curves show that face sheet bending corresponds with the 70 mm opening in the pull-out test-rig.

E.4.4.1 Standard equipment unit inserts

The general comments provided were, [29-27]:

- Load-deflection curves show a linear relationship.
- Tensile failure occurs in the (Stycast®) potting compound before a certain level of face sheet bending.
- Higher stiffness prepreg may improve the face sheet stiffness contribution to the overall insert capability.
- Face sheet thickness has an effect, although the SD values make it difficult to quantify:
 - 80 mm core thickness, showed a strength increase of ~10% max. Between a face sheet thickness of 1.08 mm and 4.86 mm.
 - 45 mm core thickness, showed no apparent strength increase between a face sheet thickness of 1.08 mm and 4.86 mm.
- Effect of core thickness: A thicker core, i.e. 80 mm compared with 45 mm provided only a small strength increase; a few %.

E.4.4.2 Through spool inserts

The general comments provided were, [29-27]:

- Load-deflection curves are more non-linear, due to face sheet bending.
- Face sheet bending occurs due to compressive loads in the potting compound.
- Face sheet thickness has an effect, although the SD values make it difficult to quantify.

E.5 References

E.5.1 General

- [29-26] 'Insert Allowable Test Programme - IATP 1'
 Kongsberg Gruppen Report No. 01TR68040906
 (May 1995)
- [29-27] 'Insert Allowable Test Programme - IATP 2'
 Kongsberg Gruppen Report No. 02TR68040906
 (October 1997)
- [29-28] Communication from MMS to Kongsberg
 'PPF-MMB-TFX-509' (13th October, 1994)

Annex F

Case studies

F.1 Introduction

This clause provides a summary of insert applications that have been applied in some European space projects, is presented, [29-29], [29-33]. The case studies give information about:

- Materials and configuration:
 - insert(s);
 - sandwich panel (face sheets, core);
 - potting.
- Testing:
 - method and sample;
 - data.

NOTE Only axi-symmetrical inserts subsequently installed in honeycomb sandwich panels are covered, i.e. co-curing of panels is excluded.
Edge inserts and metallic fittings integrated within sandwich panels are not included.

The case study concerning ROSETTA Lander also includes more general aspects of the novel design carbon fibre tube inserts from more recent evaluation studies, [29-33].

[See also: A.3]

F.1.1 European projects

The European projects, with their contractor, described are:

- ARIANE 1 equipment bay (CASA): Sandwich panels, with aluminium alloy face sheets and an aluminium honeycomb core, with standard potted Shur-lok® inserts, [See: F.2];
- ARIANE 4 equipment bay (CASA): Sandwich panels, with aluminium alloy face sheets and an aluminium honeycomb core, with standard Shur-lok® steel or special aluminium alloy potted inserts, [See: F.3];
- ASAP 4 (UTA Industrie): Sandwich panels, with aluminium alloy face sheets and an aluminium honeycomb core, with standard Shur-lok® steel or special aluminium alloy potted inserts, [See: F.4];
- ASAP 5 (MMS-UK): Sandwich panels, with aluminium alloy face sheets and an aluminium honeycomb core, with special aluminium alloy potted inserts, [See: F.5];

- ROSETTA Lander (DLR Braunschweig): Sandwich panels, with CFRP composite face sheets and aluminium honeycomb core with adhesively bonded, novel carbon fibre tube inserts, [See: F.6; A.3].
- SPOT 5 equipment bay (SONACA): Sandwich panels, with CFRP composite face sheets and a thick aluminium honeycomb core with standard Shur-lok® aluminium alloy or special aluminium alloy potted inserts, [See: F.7];
- UMS (Aérospatiale): Sandwich panels, with CFRP composite face sheets and an aluminium honeycomb core, with standard Shur-lok® aluminium alloy or special aluminium alloy potted inserts, [See: F.8];
- SILEX structure (MAN Technologie): Both standard, Shur-lok® and special aluminium alloy potted inserts were used in composite CFRP sandwich panels with aluminium alloy honeycomb cores, [See: F.9];
- HRG (MATRA Defense): Special aluminium alloy inserts were potted into sandwich panels having CFRP composite face skins and an aluminium alloy honeycomb core, [See: F.10];
- NILESAT battery (BTS): Standard Shur-lok® and special aluminium alloy inserts potted into sandwich panels with aluminium alloy face sheets and honeycomb core, [See: F.11].

A worked example of the insert verification process is given for a box mounted on a sandwich panel using potted inserts at the four corners, [See: F.12].

F.1.2 Information sources

The information presented in Annex F originates from:

- Matra Marconi Space, (MMS-Toulouse - 'Unité mécanique thermique et matériaux'): Limited to structures that MMS had charge of the definition file, associated justification data package and follow-up of manufacturers, [29-29].

NOTE Engineering drawings reproduced courtesy of MMS, [29-29]. Some of the originals supplied are of a poor quality.

- DLR Braunschweig led consortium, including Daimler-Benz Aerospace (RST Rostock), Helsinki University of Technology, Patria Finavicom for ROSETTA Lander and subsequent ESA-funded studies on carbon fibre tube inserts, [[29-30], [29-31], [29-32], [29-33]].
- The worked example is taken from the previous edition of this handbook, [29-34].

F.2 ARIANE 1 Equipment Bay

Design consists of sandwich panels, with aluminium alloy face sheets and an aluminium honeycomb core, with standard potted Shur-lok® inserts and tested under axial load.

NOTE Also applies to ASAP 4, [See also: F.4].

F.2.1 Materials and configuration

[See: Table F-1]

Table F-1: Case study: ARIANE 1 equipment bay/ASAP 4 – Allowable tensile load

Insert		Face sheets				Core		Potting	Tensile Test data				
dia (mm)	height (mm)	material	thickness (mm)	material	thickness (mm)	material	height (mm)		Temp. (°C)	Average value (N)	No. of samples	Failure mode	Note
11.48	15	Aluminium: AU4SG	0.5	Aluminium: AU4SG	0.5	6-25 (AG5)	38	AW106	RT	3136.8 2158 min 586.7 SD	24	not stated	-
17.4	15	Aluminium: AZ5GU	1.0	Aluminium: AZ5GU	1.0	4-40 (AG5)	40	SLE 3010	RT	6830 6490 min 220 SD	5	not stated	-
17.4	15	Aluminium: AZ5GU	1.0	Aluminium: AZ5GU	1.0	4-40 (AG5)	40	SLE 3010	RT	7895 7540 min 418 SD	4	not stated	-
14.22	12.7	Aluminium: AZ5GU	1.0	Aluminium: AZ5GU	1.0	4-40 (AG5)	40	SLE 3010	RT	5158 4780 min 570 SD	5	not stated	-

F.2.2 Testing

F.2.2.1 Methods

A schematic of the tensile test (insert pull-out) is shown in Figure F-1.

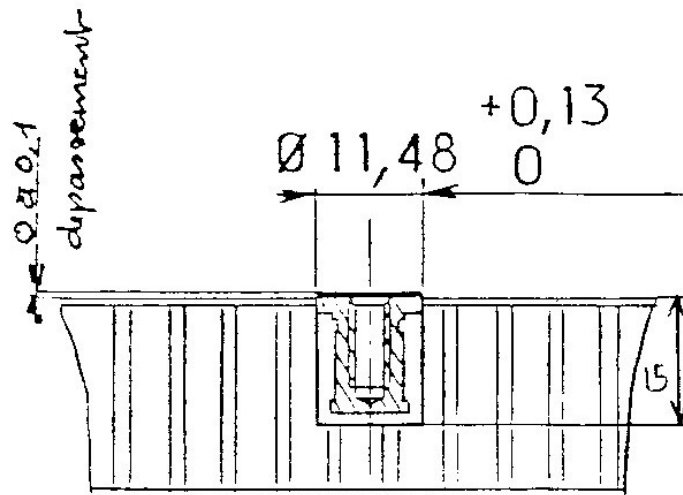

Figure F-1: Case study: ARIANE 1 equipment bay / ASAP 4 - tensile (pull-out) test method

F.2.2.2 Allowable tensile load

Figure F-1 summarises the test results.

F.3 ARIANE 4 Equipment Bay

The Design consists of sandwich panels, with aluminium alloy face sheets and an aluminium honeycomb core, and using standard Shur-lok® steel or special aluminium alloy potted inserts.

Inserts were specially designed to withstand the loads. Axial loads are often the more critical. Inserts, in particular fully potted types, are used to transmit shear loads.

F.3.1 Materials and configuration

Table F-2 lists materials and configuration examples.

F.3.2 Testing

Test samples correspond to the structure.

F.3.2.1 Methods

Testing included:

- Tensile test (insert pull-out), as shown in Figure F-4.
- Shear test, as shown in Figure F-5.

Table F-2: Case study: ARIANE 4 – materials and configuration

Project	ARIANE 4 Case 1	ARIANE 4 Case 2
Application	Equipment	Structure; handling
Insert:	[See: Figure F-2]	[See: Figure F-3]
Type	Standard Partially potted	Special Partially potted with collar
Ref.	Shur-lok® SL 607	-
Position (1)	+0.1 /0	+0.1 /0
Material	Steel	Aluminium 2024-T4
Surface treatment	Cadmium plated	Chromic anodised, not sealed
Thread	Locking	Stainless, locking
Lubrication	Molicote (titanium fixings)	Molicote (titanium fixings)
Potting:	SLE 3010 LVC	SLE 3010 LVC
Sandwich panel:		
Face sheets	Aluminium 2014-T6 Thickness: 0.5mm	Aluminium 2014-T6 Thickness: 0.5mm
Core	5056 4-40 perforated Height: 23mm	5056 4-40 perforated Height: not stated
NOTE (1)With respect to surface.		

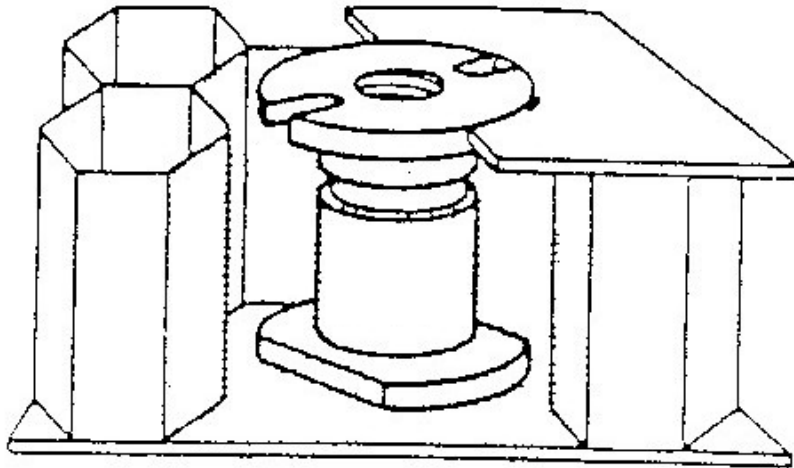

Figure F-2: Case study: ARIANE 4 Case 1

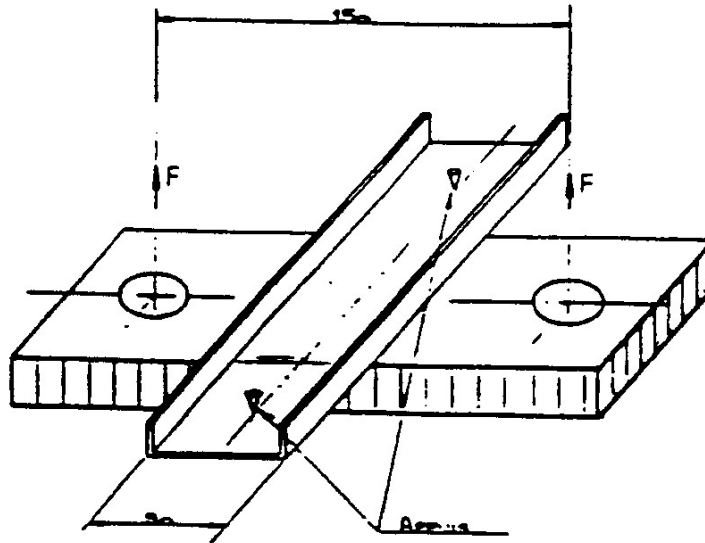

Figure F-4: Case study: ARIANE 4 - tensile (pull-out) test method

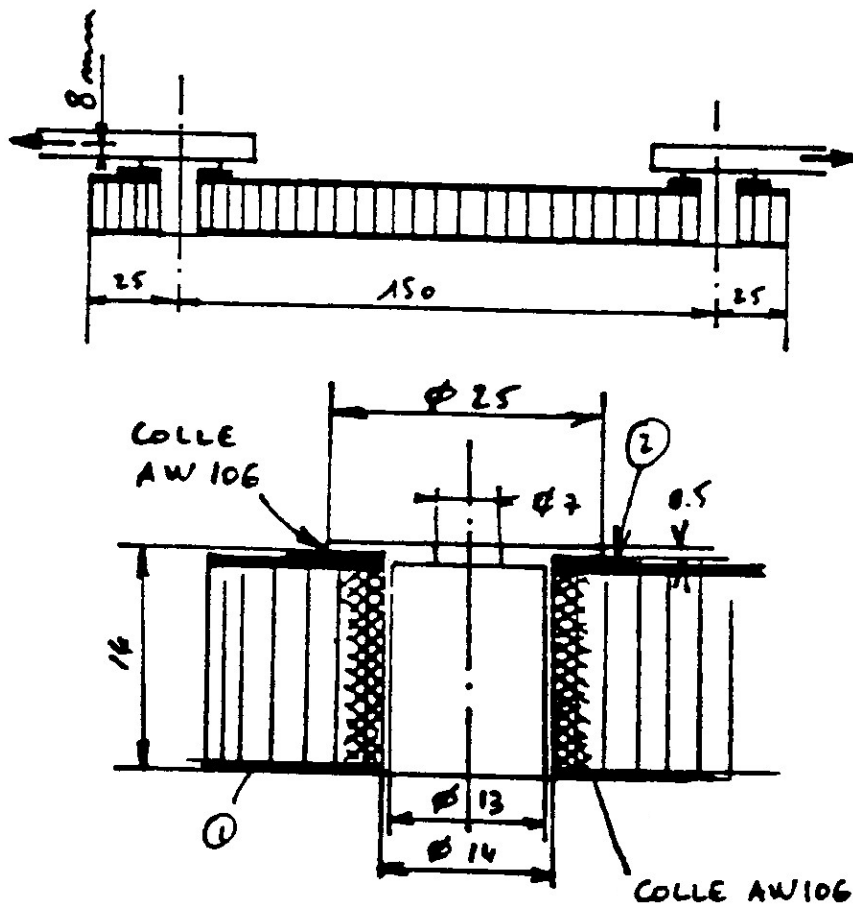

Figure F-5: Case study: ARIANE 4 - shear test method

F.3.2.2 Allowable tensile load

Table F-3 summarises tensile (insert pull-out) test results.

Table F-3: Case study: ARIANE 4 equipment bay - Allowable tensile load

Insert		Face sheets				Core		Potting	TENSILE Test data				
		Upper		Lower					Temp. (°C)	Average (N) /S.D	No. of samples	Failure mode	Note
dia. (mm)	height (mm)	material	thickness (mm)	material	thickness (mm)	material	height (mm)						
25/14	14	CFRP 108/42/G814NT	1.08	CFRP 108/42/G814NT	1.08	4-40 (AG5)	12	AW 106	20	1684 S.D. 74	4	core shear	(1)
See: diag A	65								302 S.D. 108	4	insert debonding	(1)	
	20								1256 S.D. 53	4	core shear	(2)	
30	20	Aluminium: AU4GS	1.5	Aluminium: AU4GS	1.5	4-20 (AG5)	23	EC2216	20	3144 S.D. 271	4	core shear	(3)
22/14	23	Aluminium: AU4GS	0.5	Aluminium: AU4GS	0.5	4-20 (AG5)	23	EC2216	20	2797 S.D. 103	4	core shear	(3)
									See: diag B	60	2738 S.D. 61	4	core shear
20	2240									1	core shear	(4)	
60	2210									1	core shear	(4)	

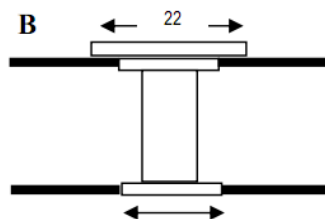
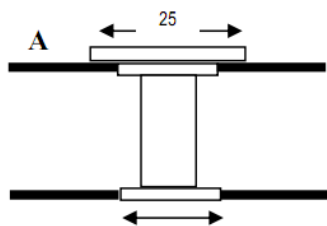

- NOTE (1) 0° CFRP = L orientation of core.
- NOTE (2) 0° CFRP = W orientation of core.
- NOTE (3) L orientation of core = length of sample.
- NOTE (4) W orientation of core = length of sample.

F.3.2.3 Allowable shear load

Table F-4 summarises shear test data.

Table F-4: Case study: ARIANE 4 equipment bay - Allowable shear load

Insert		Face sheets				Core		Potting	SHEAR Test data				
		Upper		Lower					Temp (°C)	Average value (N)	No. of samples	Failure mode	Note
dia. (mm)	height (mm)	material	thickness (mm)	material	thickness (mm)	material	height (mm)						
25/14	14	CFRP: G814NT (fabric)	1.08	CFRP:	0.38	4-20 (AG5)	12	AW 106	20	6385	2	face shear between insert and edge	(1)
See: diag A									65	5540	3	gapping and face bearing	(1)
									20	5102	4	face shear between insert and edge	(2)
									65	3892	4	gapping and face bearing	(2)
30/20	23	Aluminium: AU4SG	1.5	Aluminium: AU4SG	1.5	4-20 (AG5)	23	EC2216	20	20880	3	face shear between insert and edge	(4)
- not shown -													
22/14	23	Aluminium: AU4SG	0.5	Aluminium: AU4SG	0.5	4-20 (AG5)	23	EC2216	20	7970	5	face shear between insert and edge	(3)
See: diag B									65	7676	5	face shear between insert and edge	(3)

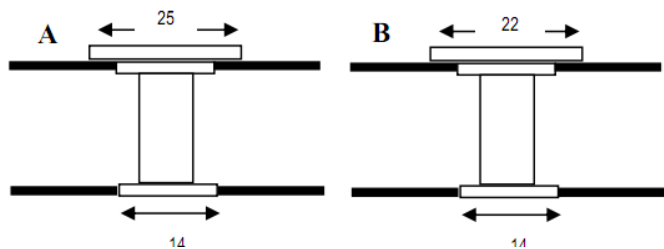

- NOTE (1) Offset between load axis and top of insert = 8mm.
- NOTE (2) Offset between load axis and top of insert = 1mm.
- NOTE (3) Load axis in mid-plane of the face.
- NOTE (4) Offset between load axis and top of insert = 6mm.

F.4 ASAP 4

The design consists of sandwich panels, with aluminium alloy face sheets and an aluminium honeycomb core, and using standard Shur-lok® steel or special aluminium alloy potted inserts.

F.4.1 Materials and configuration

Table F-5 lists materials and configuration examples.

F.4.2 Testing

F.4.2.1 Methods

Tensile tests (insert pull-out) were conducted on:

- Single insert; as shown in Figure F-1;
- Group; as shown in Figure F-8 and Figure F-9.

Table F-5: Case study: ASAP 4 – materials and configuration

Project	ASAP 4 (Ariane 4) 1	ASAP 4 (Ariane 4) 2
Application	Structure; Equipment; I/F Micro-satellite.	Structure
Insert:	[See: Figure F-6]	[See: Figure F-7]
Type	Standard Partially potted	Special Fully potted
Ref.	Shur-lok® SL601 M6 15.9S	-
Position (1)	+0.1 / 0	-
Material	Steel	Aluminium 2024-T6
Surface treatment	Cadmium plated	Chromic anodised, not sealed.
Thread	Locking	-
Lubrication	-	-
Potting:	SLE 3010 LVC	SLE 3010 LVC + primer
Sandwich panel:		
Face sheets	Aluminium 7075-T6 Thickness: 1mm	Aluminium 7075-T6 Thickness: 1mm
Core	AG5 4-40 perforated Height: 40mm	AG5 4-40 perforated Height: 40mm
NOTE (1) With respect to surface.		

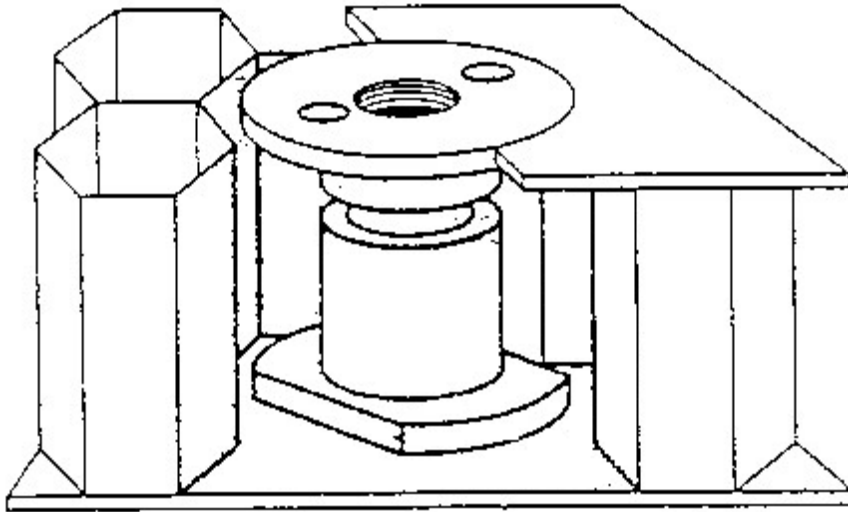

: Case study: ASAP 4

(AR4) 1

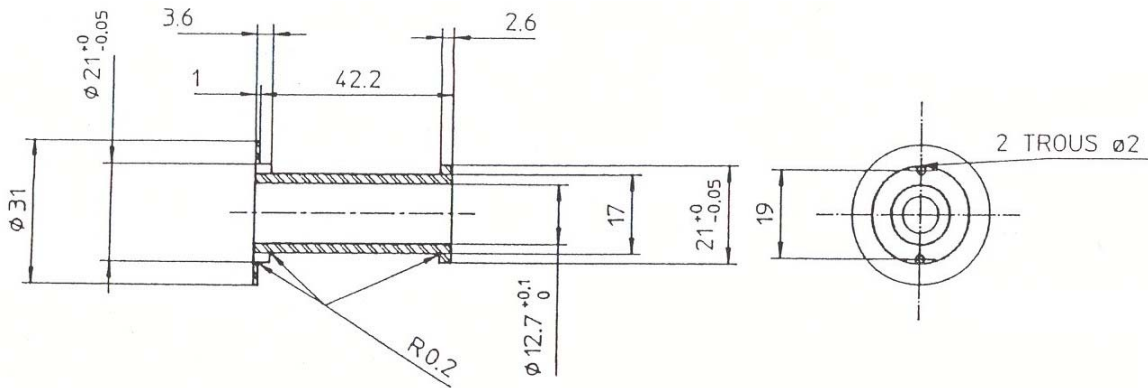

Figure F-7: Case study: ASAP 4 (AR4) 2

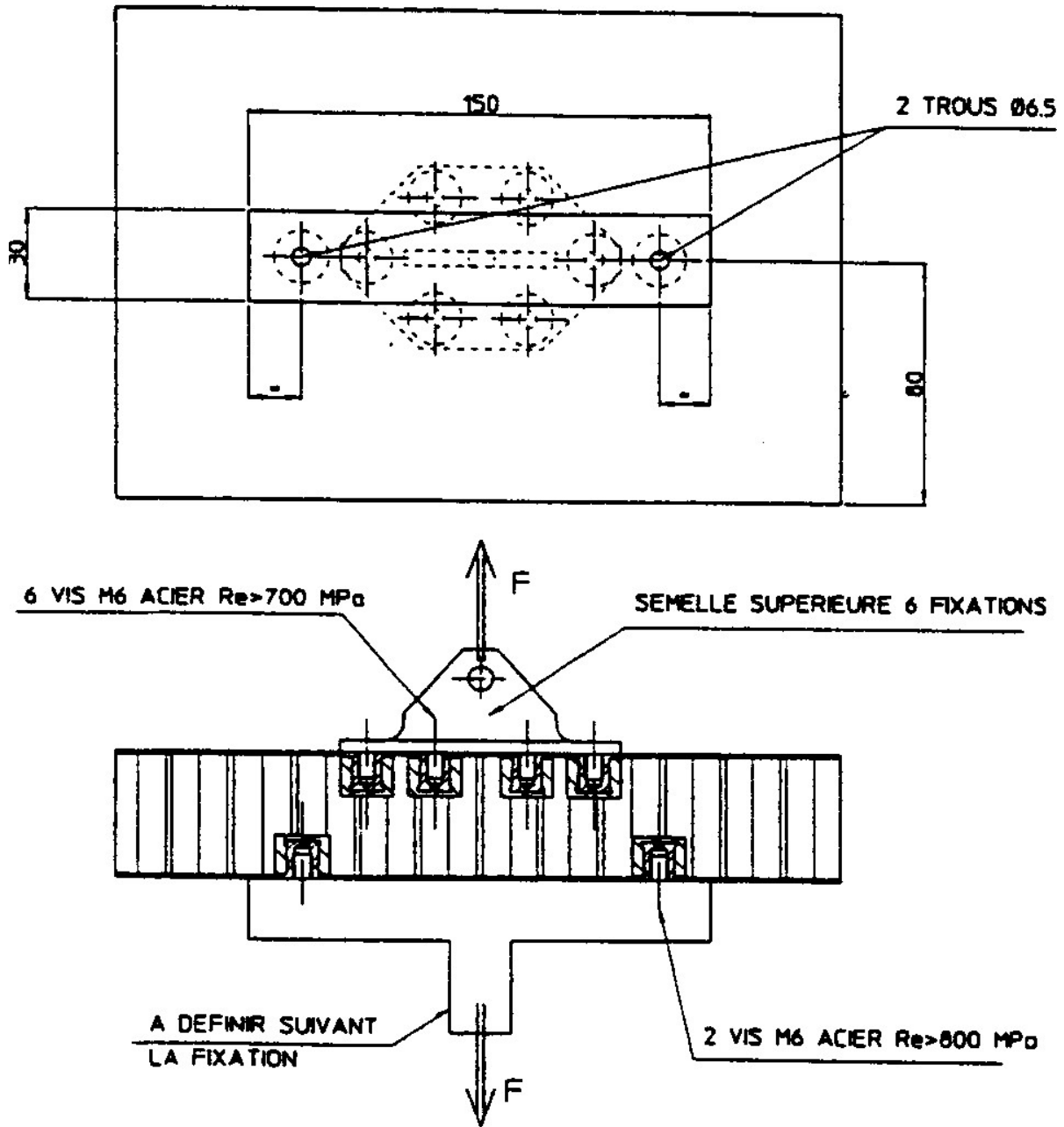

Figure F-8: Case study: ASAP 4 (AR4) - tensile (pull-out) method A

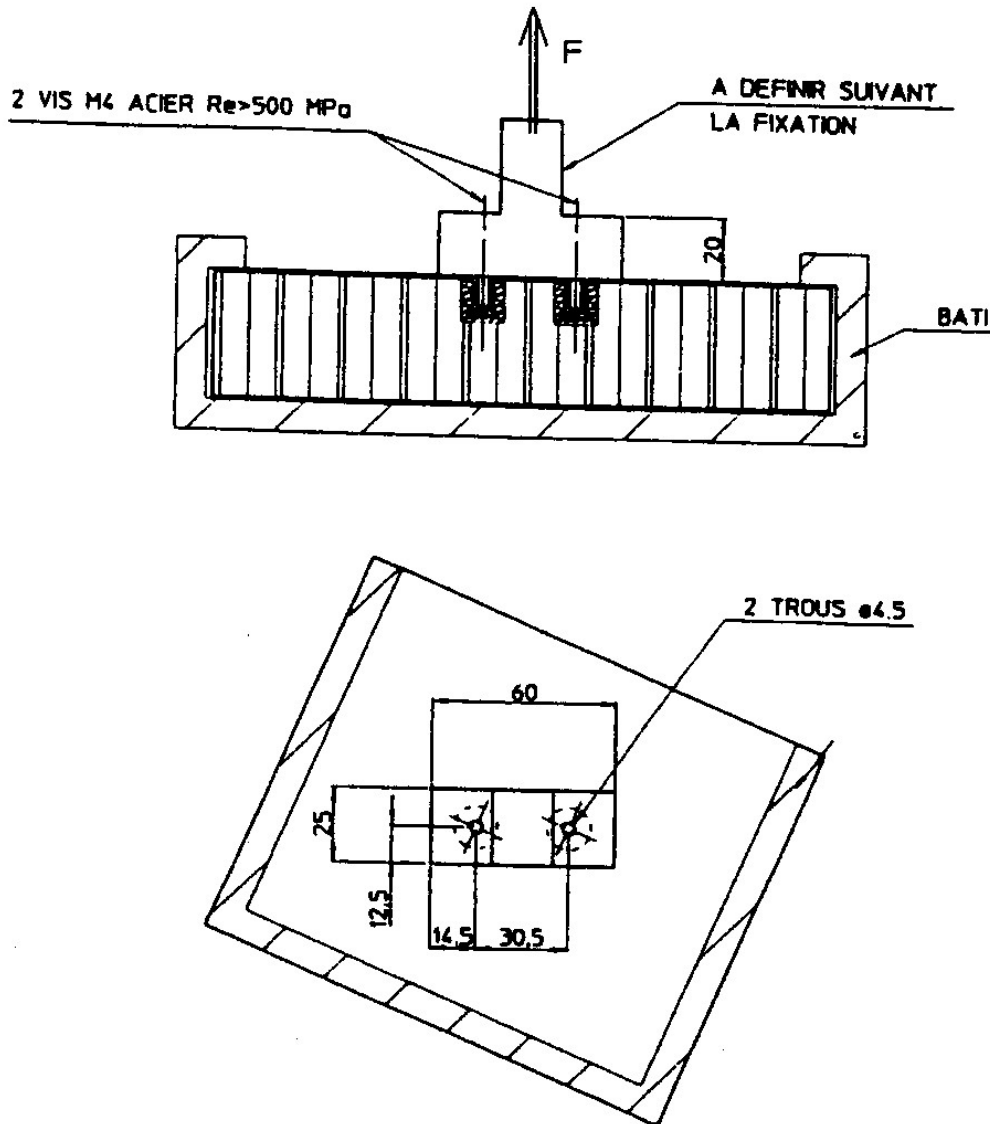

Figure F-9: Case study: ASAP 4 (AR4) - tensile (pull-out) method B

F.4.2.2 Allowable tensile load

[See: F.2; Table F-1]

F.4.2.3 Insert groups and edge effects

Hand calculation of interference and edge effects are often very difficult and can reduce insert capabilities significantly such that safety factors become negative.

During the ASAP 4 structure optimisation, margins of safety were evaluated by measurement of interference and edge coefficients.

NOTE The calculated reduction factor, using the design procedures in this handbook, is pessimistic compared with the test results; as shown in Table F-6.



Table F-6: Case study: ASAP 4 - interference and edge effects

Insert		Face sheets				Core		Potting	Test data			Interference coefficient	
		Upper		Lower					Temp. (°C)	Values (2) (N)	No. of samples	Measured	IDH (1)
dia. (mm)	height (mm)	material	thick. (mm)	material	thick. (mm)	material	height (mm)						
17.4	15	AZ5GU-T6 (7075-T6)	1.0	AZ5GU-T6 (7075-T6)	1.0	4-40 (AG5)	40	SLE 3010	RT	Av: 7875	4	-	-
Shurlok SL601 Single										Min: 6240			
17.4	15	AZ5GU-T6 (7075-T6)	1.0	AZ5GU-T6 (7075-T6)	1.0	4-40 (AG5)	40	SLE 3010	RT	Av: -	1	0.72	0.39
Shurlok SL601 Group (A)										Min: 27120			
17.4	15	AZ5GU-T6 (7075-T6)	1.0	AZ5GU-T6 (7075-T6)	1.0	4-40 (AG5)	40	SLE 3010	RT	Av: 14350	3	0.83	0.59
Shurlok SL601 Group (A)										Min: 13770			
14.22	12.7	AZ5GU-T6 (7075-T6)	1.0	AZ5GU-T6 (7075-T6)	1.0	4-40 (AG5)	40	SLE 3010	RT	Av: 5158	5	-	-
Shurlok SL601 Single										Min: 3220			
14.22	12.7	AZ5GU-T6 (7075-T6)	1.0	AZ5GU-T6 (7075-T6)	1.0	4-40 (AG5)	40	SLE 3010	RT	Av: 10550	3	0.78	0.65
Shurlok SL601 Group (B)										Min: 8250			

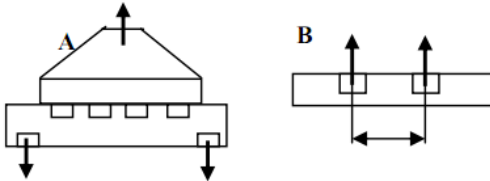

NOTE (1) IDH = calculated using design methods given in this Handbook.
 NOTE (2) Av = Average; Min = minimum; SD = standard deviation.

F.5 ASAP 5

Design consisting of sandwich panels, with aluminium alloy face sheets and an aluminium honeycomb core, using special aluminium alloy potted inserts.

Special through-the-thickness (fully potted) inserts were used in thick sandwich structures, i.e. core height = 60 mm.

F.5.1 Materials and configuration

Table F-7 lists materials and a configuration example.

F.5.2 Testing

Special through-the-thickness (fully potted) inserts were used in thick sandwich structures, i.e. core height = 60mm.

- The effect of potting from one or both sides of the sandwich was examined.
- Test results, when compared with analysis methods in this handbook, show that the minimum value exceeds the calculated typical value.
- Insert proximity effects were investigated.

F.5.2.1 Method

No details given, [29-29].

Table F-7: Case study: ASAP 5 – materials and configuration

Project	ASAP 5
Application	Structure: Separation system mini- and micro-satellites
Insert:	[See: Table F-10]
Type	Special through-the-thickness (Fully potted)
Ref.	-
Position (1)	-
Material	7175-T7351
Surface treatment	Chromic anodised, not sealed. Alodine® 1200 (contact surface).
Thread	Non-locking, phosphor bronze Cd-free.
Lubrication	Molicote 106
Potting:	SLE 3010 LVC + primer
Sandwich panel:	
Face sheets	Aluminium 2024-T81 Thickness: 0.8 mm
Core	5056 4-40 perforated Height: 60 mm
NOTE (1) With respect to surface.	

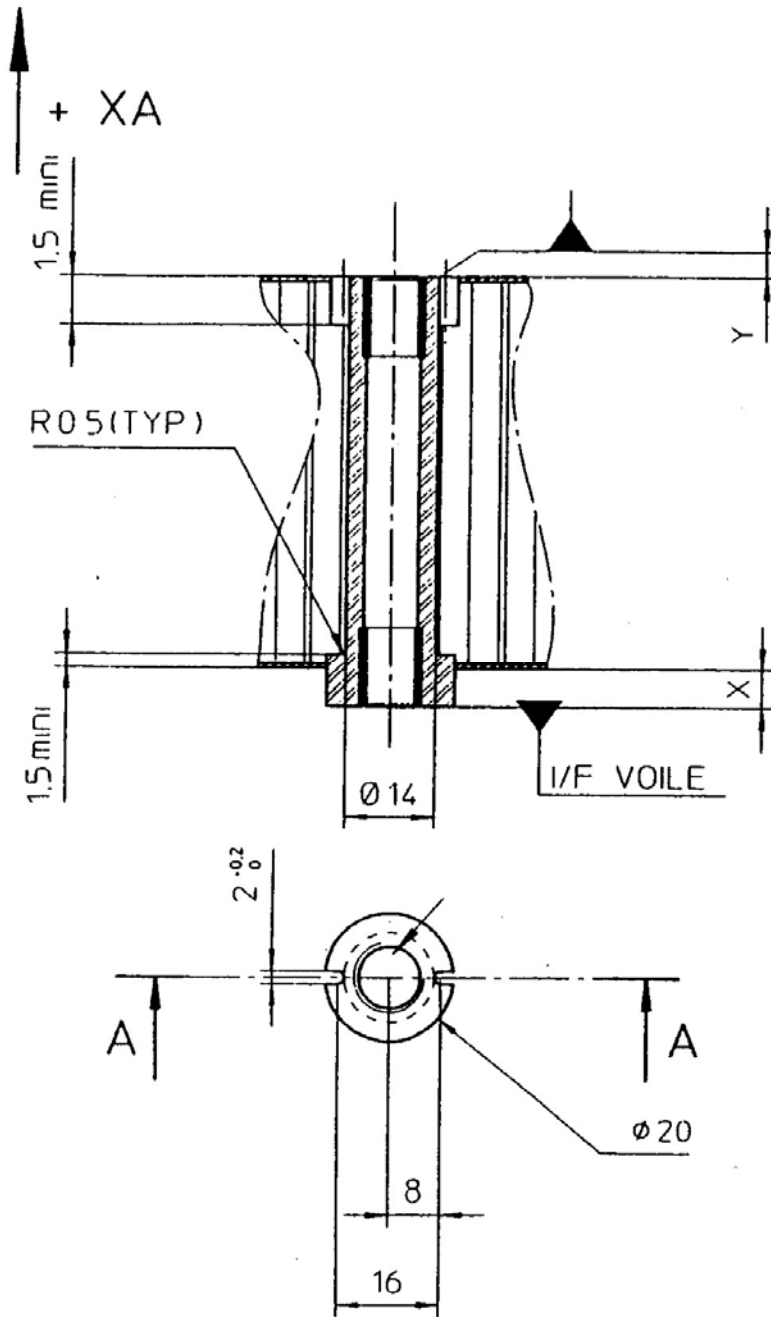

Figure F-10: Case study: ASAP 5



F.5.2.2 Allowable tensile load

Table F-8 summarises the test results.

Table F-8: Case study: ASAP 5 - Allowable tensile load

Insert		Face sheets				Core		Potting (2)	Test data				
		Upper		Lower					Temp. (°C)	Average Value (N)	No. of samples	Failure mode	Note
dia. (mm)	height (mm)	material	thickness (mm)	material	thickness (mm)	material	height (mm)						
25	>62	Aluminium: AU4G1-T81 (2024-T81)	0.8	Aluminium: AU4G1-T81 (2024-T81)	0.8	4-45 (AG5) (5056)	60	BSL 312UL 1-side	RT	18340	5	not stated	(1)
										17500 min. IDH typ. 14885			
25	>62	Aluminium: AU4G1-T81 (2024-T81)	0.8	Aluminium: AU4G1-T81 (2024-T81)	0.8	4-45 (AG5) (5056)	60	BSL 312UL 2-sides	RT	20180	5	not stated	(1)
										18500 min. IDH typ. 14885			
20	>62	Aluminium: AU4G1-T81 (2024-T81)	0.8	Aluminium: AU4G1-T81 (2024-T81)	0.8	4-45 (AG5) (5056)	60	BSL 312UL 1-side	RT	15360	5	not stated	(1)
										15000 min. IDH typ. 13031			
20	>62	Aluminium: AU4G1-T81 (2024-T81)	0.8	Aluminium: AU4G1-T81 (2024-T81)	0.8	4-45 (AG5) (5056)	60	BSL 312UL 2-sides	RT	15440	5	not stated	(1)
										14900 min. IDH typ. 10031			
20	>62	Aluminium: AU4G1-T81 (2024-T81)	0.8	Aluminium: AU4G1-T81 (2024-T81)	0.8	4-45 (AG5) (5056)	60	BSL 312UL 1-side	RT	16320	5	not stated	(1)
Type ACU										14900 min. IDH typ. 10031			

NOTE (1) IDH typ. = predicted 'typical value' calculated using design methods given in this handbook.

NOTE (2) Potting from one-side or from both (2-sides) of sandwich panel.



F.5.2.3 Insert groups and edge effects

Some inserts, tested individually [See: Table F-8], were also tested in a group, as given in Table F-9.

The distance between inserts, $d = 33.8$ mm.

NOTE The calculated reduction factor, using the design procedures in this handbook, are pessimistic compared with the test results; as shown in Table F-9.

Table F-9: Case study: ASAP 5 - interference and edge effects

Insert		Face sheets				Core		Potting (3)	Test data			Interference coefficient	
		Upper		Lower					Temp. (°C)	Values (2) (N)	No. of samples	Measured	IDH (1)
dia. (mm)	height (mm)	material	thick (mm)	material	thick (mm)	material	height (mm)						
25	>62	AU4GA-T81 (2024-T81)	0.8	AU4GA-T81 (2024-T81)	0.8	4-45 (AG5)	60	BSL 312UL	-	Av: 20180	5	-	-
Single										Min: 18500			
25	>62	AU4GA-T81 (2024-T81)	0.8	AU4GA-T81 (2024-T81)	0.8	4-45 (AG5)	60	BSL 312UL	-	Av: >43220	1	>0.43	0.23
Group										Min: -			
20	>62	AU4GA-T81 (2024-T81)	0.8	AU4GA-T81 (2024-T81)	0.8	4-40 (AG5)	60	BSL 312UL	-	Av: 16320	5	-	-
Single										Min: 14900			
20	>62	AU4GA-T81 (2024-T81)	0.8	AU4GA-T81 (2024-T81)	0.8	4-40 (AG5)	60	BSL 312UL	-	Av: 49000	3	>0.54	0.27
Group										Min: 44400			

NOTE (1) IDH = calculated using design methods given in this handbook.

NOTE (2) Av = Average; Min = Minimum.

NOTE (3) Potting from one side of the panel only.

F.6 ROSETTA Lander

F.6.1 Carbon fibre tube inserts

Design consisting of sandwich panels, with CFRP composite face sheets and aluminium honeycomb core, using adhesively bonded, novel, carbon-fibre-tube inserts, [See also: A.3].

F.6.2 Development history

The development of the comet Lander 'Philae' for the ESA cornerstone mission ROSETTA was performed by a European consortium led by DLR. In this DLR Braunschweig developed and built a complex lightweight structure based on carbon fibre sandwich plates with several hundreds of inserts. Many of these inserts were needed for through-the-thickness fasteners.

Figure F-11 shows two of the Lander's structural components.

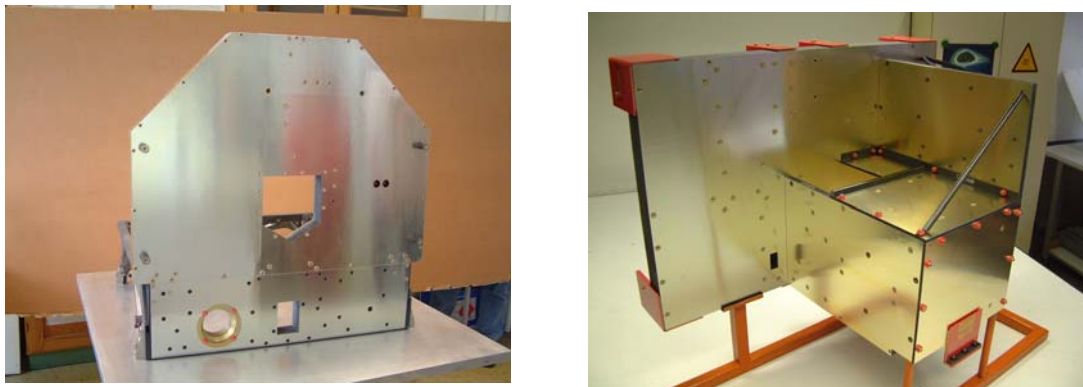

Figure F-11: ROSETTA Lander: Two structural components

The tight constraints of the mass budget, the given thickness of the sandwich plates, and the number of inserts per unit area made it inevitable that conventional potted insert design had to be replaced by a novel design, [29-30]; known as a carbon-fibre tube insert, [See also: A.3 for details].

The concept is based on an extremely stiff, thin-walled carbon fibre tube which fits exactly between the face sheets and is bonded to the honeycomb core only by a thin layer of epoxy adhesive. The 'potting radius' is therefore not much larger than the insert radius itself.

The full length of the extremely stiff carbon fibre tube actively contributes to the shear load transfer into the much softer honeycomb core, because the tube always passes through the whole sandwich thickness. The form-locking contact under both face sheets makes the sandwich in the vicinity of the insert practically incompressible.

In the course of the verification process of the ROSETTA Lander, the qualification of the new insert design was performed with regard to the specific mission requirements and the specific structural configuration.

A preliminary test campaign was performed, [[29-31], [29-32]], and the final flight readiness was proven by successful mechanical tests at Lander level (spacecraft level). However, a qualification of the insert design under more general conditions remained to be done.

F.6.3 Qualification

Based on the experience from the ROSETTA Lander project, the potential of carbon fibre tube inserts was investigated more thoroughly by DLR and two Finnish partners, PATRIA Finavicom Oy and Helsinki University of Technology, during an ESA-funded study, [29-33].

The influence of the sandwich parameters on the static and dynamic strength of the inserts under different load cases was systematically investigated. The influence of thermal conditioning before testing, edge effects and the effect of the insert size were also considered. All tests were made on both types of metallic insert caps; as described in A.3.

The experimental investigations were performed with the test fixtures; shown in Figure F-12, [See also: Annex H].

Parallel, analytical investigations and numerical calculations based on a detailed FE model were carried out.



Bending and tension-compression tests (top row)

Torsion and shear tests (bottom row)

Figure F-12: ROSETTA Lander: Tension-compression, shear, bending and torsion tests

F.6.4 Preliminary results

As of July 2004, the evaluation stage of the study is not yet complete, [29-33].

In parallel to the tests, insert strength values were determined:

- analytically, using the formulae given in this handbook;
- numerically, using FEM calculations.

The results are in the same order of magnitude as the test results, but the congruity between analysis and testing still needs further evaluation. Likewise, special effects, e.g. edge effects, size effects, thermal influences and the fatigue behaviour need further consideration. More results can be incorporated into this handbook when the data are available.

The preliminary results are summarised in Table F-10 to Table F-12, inclusive. These are restricted to the basic static load cases and the influence of fundamental sandwich parameters on the insert strength.

The results given are for a sandwich panel construction comprising of:

- face sheets (top and bottom) made of orthotropic carbon fibre fabric plies, fabric style 887 (manufactured by C. Cramer & Co), based on TORAYCA M40 JB-6000-50-B carbon fibres, with an epoxy matrix (Scheufler Resin L 160 / Hardener H 163) and a fibre volume fraction of $\approx 50\%$, in two different thicknesses (0.5 mm and 1.5 mm).
- honeycomb core, made from aluminium alloy by HEXCEL in 2 core thicknesses (20 mm and 50 mm) and in 3 material specifications, namely:
 - Aeroweb CR III-1/4-5052-0007 P
 - Aeroweb CR III-1/4-5052-0015 P
 - Aeroweb CR III-1/8-5052-0007 P

This enables 2 different cell sizes (1/4 inch ≈ 6 mm and 1/8 inch ≈ 3 mm) and 2 different cell wall thicknesses (0.0015 inch and 0.0007 inch) to be compared.

NOTE 1 The face sheets each consisted of six orthotropic layers ($0^\circ/90^\circ$), in order to investigate the influence of face sheet thickness. In realistic applications, however, a six layer face sheet would certainly contain 45° fibres in addition to the $0^\circ/90^\circ$. This leads to a much higher bearing strength, and thus to higher critical insert shear loads than those listed in Table F-12.

NOTE 2 Large out-of-plane forces (tension / compression) tend to crush the honeycomb core parallel to one of the face sheets. Usually this is the face sheet pressed against the test fixture. This tension-compression test fixture for 80 mm \times 80 mm sandwich specimens had a central hole of 70 mm diameter [See: Figure F-12]. The support area was clearly too small to avoid this. Otherwise the measured critical out-of-plane loads would be even higher than those listed in Table F-10 and Table F-11.

Only the test results obtained with insert caps for unilateral fixing, shown in Figure F-13, are listed, but the results obtained with the alternative insert cap type for through-thickness fasteners are similar.

Table F-10: Carbon fibre tube inserts: Out-of-plane tension

Tension Test out-of-plane 1 mm / min insert Ø 12 mm	honeycomb core thickness	face sheet thickness	honeycomb core density	honeycomb core cell size	critical insert load on A-, B-, C-level (95% confidence)			critical insert load mean value (of 8) [kN]
	<i>c</i> [mm]	<i>f</i> [mm]	ρ [kg/m ³]	<i>s</i> [mm]	A 99%	B 95%	C 90%	
	<i>c</i> [mm]	<i>f</i> [mm]	ρ [kg/m ³]	<i>s</i> [mm]	[kN]	[kN]	[kN]	
standard case	50	1.5	50	6	4.22	5.22	5.73	7.60
small cell size	50	1.5	50	3	3.00	3.53	3.82	4.82
thin face sheet	50	0.5	50	6	4.66	5.32	5.63	6.74
lightweight core	50	0.5	25	6	1.21	1.37	1.46	1.76
small thickness	20	0.5	50	6	1.10	1.34	1.45	1.90
small and light	20	0.5	25	6	0.83	0.88	0.91	0.98

Table F-11: Carbon fibre tube inserts: Out-of-plane compression

Compression Test out-of-plane 1 mm / min insert Ø 12 mm	honeycomb core thickness	face sheet thickness	honeycomb core density	honeycomb core cell size	critical insert load on A-, B-, C-level (95% confidence)			critical insert load mean value (of 8) [kN]
	<i>c</i> [mm]	<i>f</i> [mm]	ρ [kg/m ³]	<i>s</i> [mm]	A 99%	B 95%	C 90%	
	<i>c</i> [mm]	<i>f</i> [mm]	ρ [kg/m ³]	<i>s</i> [mm]	[kN]	[kN]	[kN]	
standard case	50	1.5	50	6	6.41	7.08	7.37	8.38
small cell size	50	1.5	50	3	3.44	4.12	4.45	5.68
thin face sheet	50	0.5	50	6	5.01	5.58	5.84	6.74
lightweight core	50	0.5	25	6	1.23	1.40	1.49	1.78
small thickness	20	0.5	50	6	1.00	1.27	1.40	1.93
small and light	20	0.5	25	6	0.75	0.83	0.86	0.98

Table F-12: Carbon fibre tube inserts: In-plane shear load

Shear Test in-plane 1 mm / min insert Ø 12 mm	honeycomb core thickness	face sheet thickness	honeycomb core density	honeycomb core cell size	critical insert load on A-, B-, C-level (95% confidence)			critical insert load mean value (of 8)
					A 99%	B 95%	C 90%	
	<i>c</i> [mm]	<i>f</i> [mm]	ρ [kg/m ³]	<i>s</i> [mm]	[kN]	[kN]	[kN]	[kN]
standard case	50	1.5	50	6	2.74	3.96	4.61	7.40
small cell size	50	1.5	50	3	4.12	4.98	5.41	6.98
thin face sheet	50	0.5	50	6	1.32	1.88	2.19	3.56
lightweight core	50	0.5	25	6	1.08	1.47	1.69	2.63
small thickness	20	0.5	50	6	1.41	1.81	2.03	2.83
small and light	20	0.5	25	6	0.53	0.96	1.22	2.62

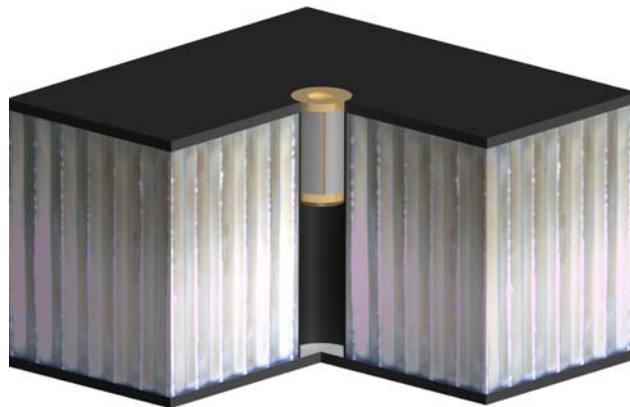

Figure F-13: Carbon fibre tube insert (type 2): With cap for unilateral fixing

The critical insert failure load F_c was determined from each individual load curve; where F_c is a general term for the critical static strength in the different load cases, e.g. P_{ss} for tension-compression; Q_{ss} for in-plane shear; T_{ss} for torsion; M_{ss} for bending.

In all cases, F_c was defined as the load upon which the first failure or plastic deformation occurs. It is observable as the first maximum of the curve or as the obvious end of the linear elastic range; as shown in Figure F-14. In many cases the load increased even beyond F_c up to a maximum value F_{max} . However, F_c was regarded as the only relevant parameter; in line with a conservative design philosophy.

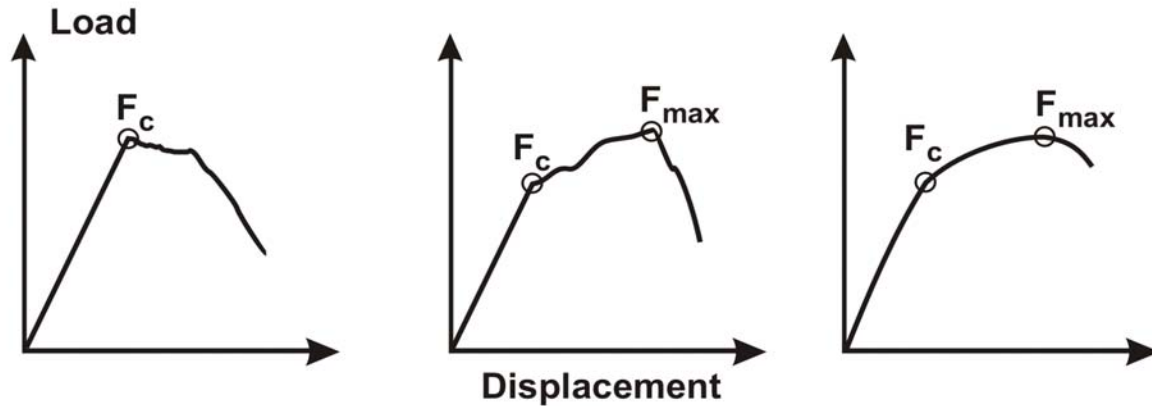

Figure F-14: Carbon fibre tube inserts: Definition of the critical insert failure load, F_c

Normally there were 8 experimentally determined critical load values per test scenario, i.e. per combination of sandwich type, insert cap type, and load case.

NOTE Mean values are listed in the right-hand column of Table F-10 to Table F-12, inclusive.

The data were processed by the 'Weibull ++5.0' computer program from 'Relia Soft'. For each test scenario a Weibull distribution was generated, which indicates 'survivable' critical load levels without any insert failures or plastic deformation. These criteria are summarised in Table F-13.

Table F-13: Carbon fibre inserts: Weibull analysis criteria

99% probability of survival	1% probability of failure	so-called A-level
95% probability of survival	5% probability of failure	so-called B-level
90% probability of survival	10% probability of failure	so called C-level

All three levels were determined on a statistical confidence level of 95%. They are, of course, lower than the mean value; the difference depends on the scatter within the distribution.

F.7 SPOT 5

Design consisting of sandwich panels, with CFRP composite face sheets and a thick aluminium honeycomb core (height of 80 mm), and using standard Shur-lok® aluminium alloy or special aluminium alloy potted inserts.

F.7.1 Materials and configuration

Table F-14 lists materials and configuration examples.

F.7.2 Testing

No details given in [29-29].

Table F-14: Case study: SPOT 5 – materials and configuration

Project	SPOT 5 CASE	SPOT 5
Application	Equipment	Structure I/F platform
Insert:	[See: Figure F-15]	[See: Figure F-16]
Type	Standard	Special
Ref.	Shur-lok® SL100530 M4 Partially potted	Fully potted
Position (1)	+0.1 / 0	-
Material	Aluminium 2024-T4	Aluminium 7175-T7351
Surface treatment	Chromic anodise, not sealed. Alodine 1200 contact face.	Chromic anodise, not sealed. Alodine® 1200 remachined face.
Thread	M4	M12, non-locking. Phosphor bronze, Cd-free.
Lubrication	Molicote 106	Molicote 106
Potting:	SLE 3010 LVC + primer	SLE 3010 LVC + primer
Sandwich panel:		
Face sheets	CFRP Thickness: 1 mm	CFRP Thickness: 1 mm
Core	5056 3-16 perforated Height: 80 mm	5056 3-16 perforated Height: 80 mm
NOTE (1) With respect to surface.		

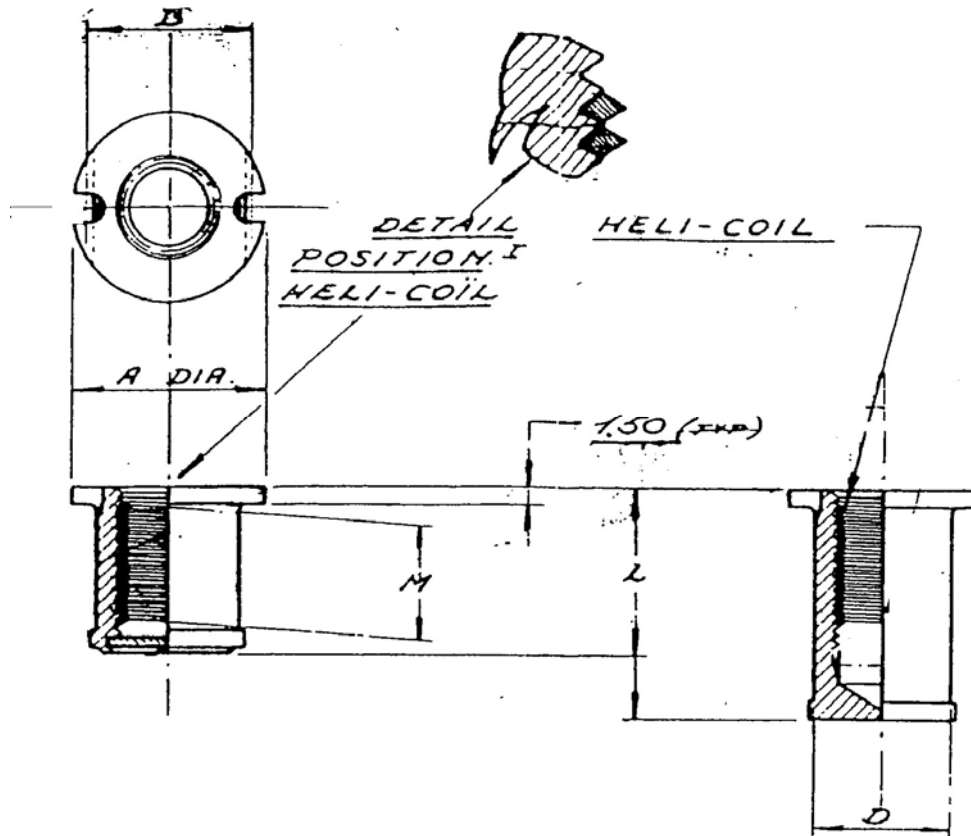

SPOT 5 - Case

: Case study:

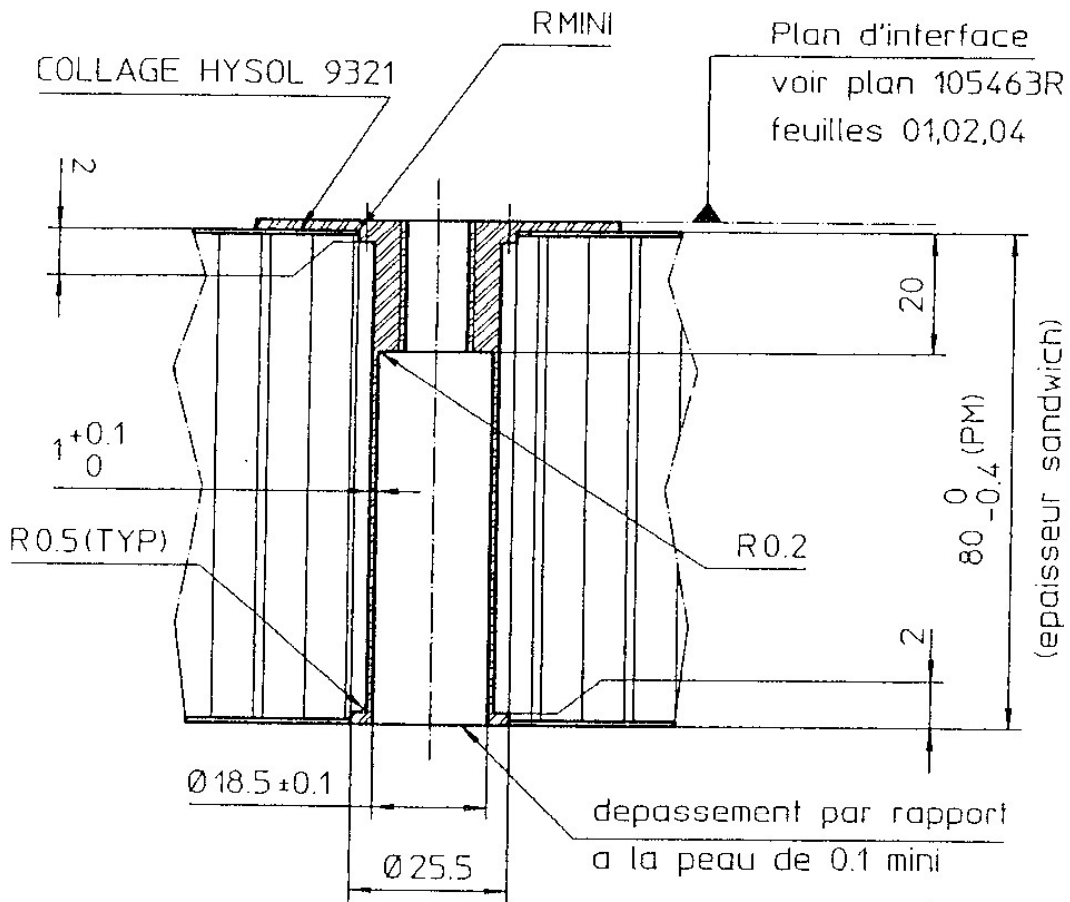

FILET RAPPORTE; M12x1.5, NON FREINE
 BRONZE PHOSPHOREUX NON CADMIE,
 PROFONDEUR 18 MINI (1.5 D),
 ENTRAINEUR ROMPU.

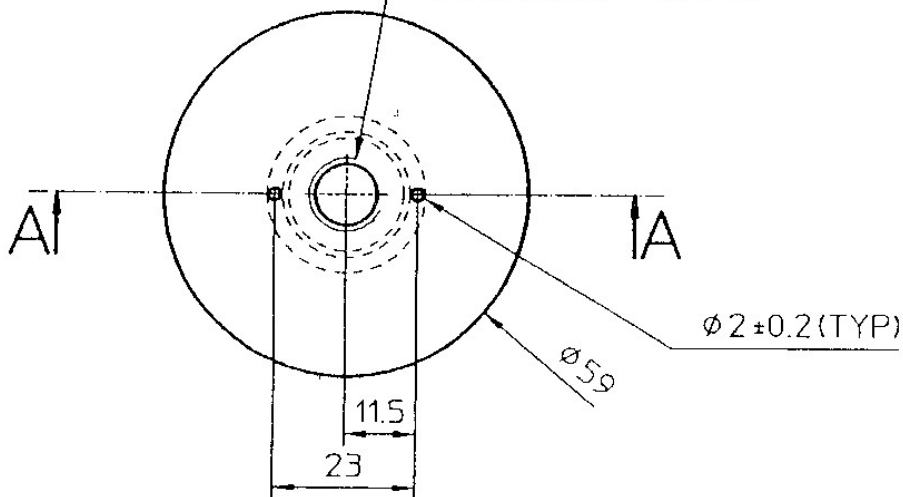

Figure F-16: Case study: SPOT 5 - Structure I/F platform



F.8 UMS

Design consisting of sandwich panels, with CFRP composite face sheets and an aluminium honeycomb core, and using standard Shur-lok® aluminium alloy or special aluminium alloy potted inserts.

F.8.1 Materials and configuration

Table F-15 lists materials and configuration examples.

F.8.2 Testing

Table F-15: No details given, [29-29]. Case study: UMS – Materials and configuration

Project	UMS-SST	UMS-SST
Application	Structure (radiator)	Structure (platform/case)
Insert:	[See: Figure F-17]	[See: Figure F-18]
Type	Standard	Special
Ref.	Shur-lok SL601 M4-9.5A Partially potted	Fully potted
Position (1)	-	-
Material	Aluminium 2024-T4	Aluminium AU4G1-T351
Surface treatment	Anodised.	Chromic anodise, not sealed.
Thread	M4, locking.	Stainless, non-locking.
Lubrication	Molicote 106 (titanium fixings)	Molicote 106 (titanium fixings)
Potting:	-	-
Sandwich panel:		
Face sheets	CFRP Thickness: 0.8 mm	CFRP Thickness: 0.8 mm
Core	AG5 4-20 4-40 3-58 Height: not stated.	AG5 4-20 4-40 3-58 Height: not stated.

NOTE (1) With respect to surface.

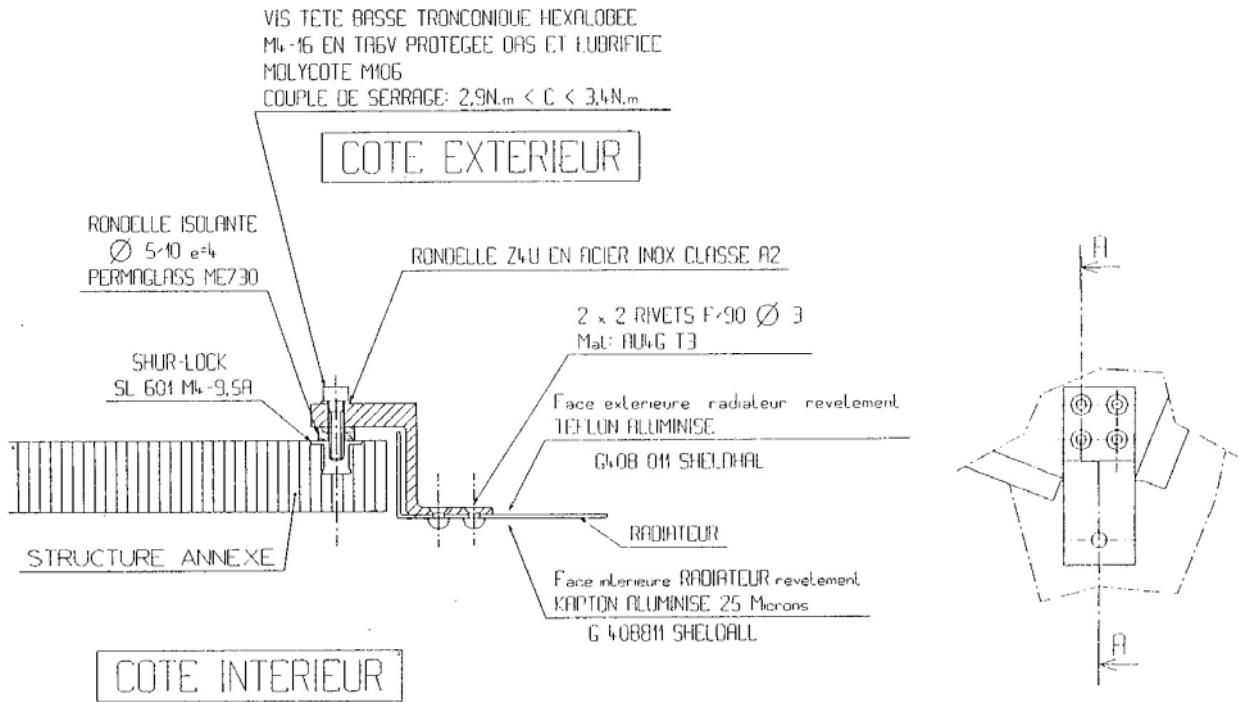
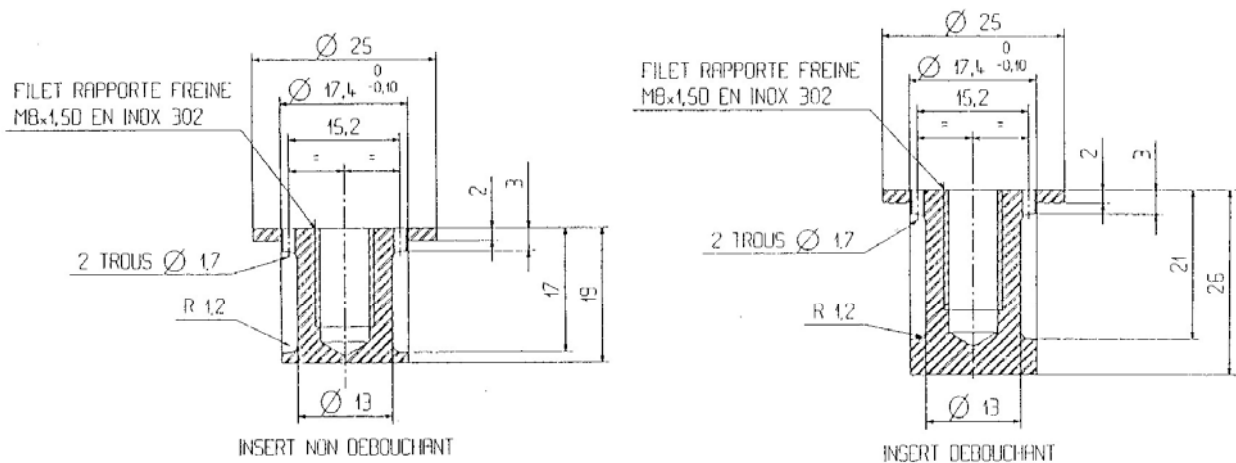

Figure F-17: Case study: UMS - SST 1



Tolerances generales: $\pm 0,1$
 Matiere: AU4G1 T351.
 Protection: DAC non colmatee.

Figure F-18: Case study: UMS - SST 2

F.9 SILEX

Both standard, Shur-lok® and special aluminium alloy potted inserts were used in composite CFRP sandwich panels with aluminium alloy honeycomb cores.

F.9.1 Materials and configuration

Table F-16 shows materials and configuration examples.

F.9.2 Testing

NOTE No details of test methods given in [29-29].

Table F-16: Case study: SILEX – Materials and configuration

Project	SILEX	SILEX GEO MPCS
Application	Structure Equipment	Structure
Insert:	[See: Figure F-19]	[See: Figure F-20]
Type	Standard Partially potted	Special Fully potted
Ref.	Shur-lok SL10068	-
Position (1)	0 -0.05	-
Material	Aluminium 2024-T4	Aluminium 7075-T73
Surface treatment	Anodised MIL-A-8625	Chromic anodised, not sealed
Thread	Non-locking	Stainless, non-locking
Lubrication	Nuflon (on bolt)	Nuflon
Potting:	Shur-lok SLE3010 LVC	Shur-lok SLE3010 LVC
Sandwich panel:		
Face sheets	CFRP: Thickness: 0.8 mm - 1.6 mm	CFRP: Thickness: 0.8 mm - 1.6 mm
Core	5056: 4-20 3-20 3-28 3-45	5056: 4-20 3-20 3-28 3-45
NOTE (1) With respect to surface.		

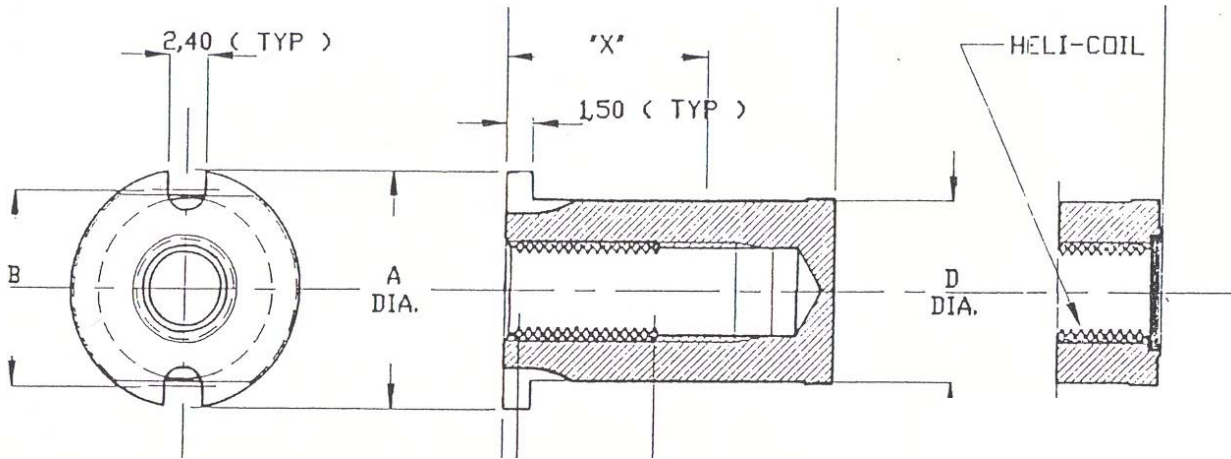

Figure F-19: Case study: SILEX - insert

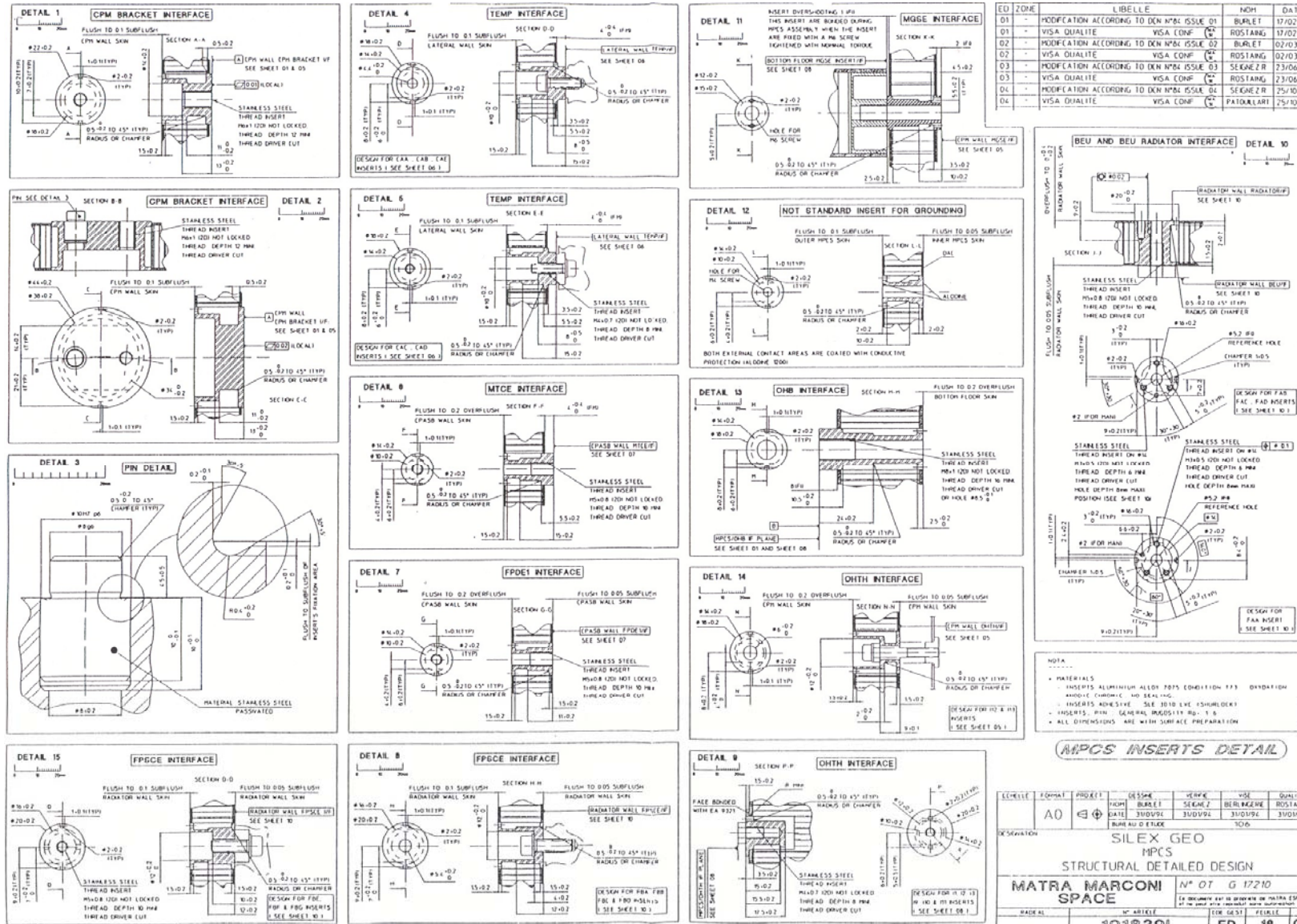

Figure F-20: Case study: SILEX GEO MPCS – insert

F.9.2.2 Allowable tensile load

Test results are for transverse tensile loading are summarised in Table F-17.

Table F-17:Case study: SILEX - Allowable tensile load

Insert		Face sheets				Core		Potting	TENSILE Test data				
		Upper		Lower					Temp (°C)	Average value (N)	No. of samples	Failure mode	Note
dia. (mm)	height (mm)	material	thickness (mm)	material	thickness (mm)	material	height (mm)						
14	15	CFRP: M55J isotropic lay-up	1.6	CFRP: M55J isotropic lay-up	1.6	4-20 5056	55.7	SLE 3010 LVC	RT	2490 2320 min	5	honeycomb shear	-
Shurlok - not stated -													
50 TBC	20	CFRP: M55J isotropic lay-up	0.8	CFRP: M55J isotropic lay-up	0.8	4-40 5056	18.6	SLE 3010 LVC	RT	6950	1	honeycomb shear	-
SK-8065- E//SN004													
18	35	CFRP: M55J isotropic lay-up	1.6	CFRP: M55J isotropic lay-up	1.6	3-58 5056	28	SLE 3010 LVC	RT	9950	1	-	(1)
MPCS/OA SK-8155- E//SN011													
14	15	CFRP: M55J isotropic lay-up	0.8	CFRP: M55J isotropic lay-up	0.8	3-20 5056	16.5	SLE 3010 LVC	RT	2524 2475 min	3	-	(2)
Shurlok SL10068 M5-3-S													
14	18.1	CFRP: M55J isotropic lay-up	0.8	CFRP: M55J isotropic lay-up	0.8	3-20 5056	16.5	SLE 3010 LVC	RT	2282 2187 min	3	not stated	
FPDE1 SK-8552-F													
25/12	25	CFRP: GY70 isotropic lay-up	0.4	CFRP: GY70 isotropic lay-up	0.4	9-48 (AG5)	43	SLE 3010	RT	4936.1 3050 min	28	not stated	
See: diag A													

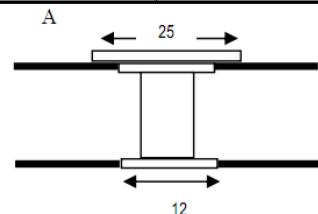

NOTE (1) Cracking noise, no visible damage.
NOTE (2) First cracking noise heard at 2100N.



F.9.2.3 Allowable shear load

The results of in-plane shear testing are summarised in Table F-18.

Table F-18: Case study: SILEX - Allowable shear load

Insert		Face sheets				Core		Potting	SHEAR Test data				
		Upper		Lower					Temp (°C)	Average value (N)	No. of samples	Failure mode	Note
dia. (mm)	height (mm)	material	thickness (mm)	material	thickness (mm)	material	height (mm)						
-	-	CFRP: M55J isotropic lay-up	1.6	CFRP: M55J isotropic lay-up	1.6	4-20 5056	55.7	SLE 3010 LVC	RT	7350 7250 min	2	face skin bearing	-
Shurlok SL10068 M5-3-S													
14	15	CFRP: M55J isotropic lay-up	0.8	CFRP: M55J isotropic lay-up	0.8	3-20 5056	16.5	SLE 3010 LVC	RT	4426 4140 min	3	face skin bearing	-
Shurlok SL10068 M5-3-S													
14	18.1	CFRP: M55J isotropic lay-up	0.8	CFRP: M55J isotropic lay-up	0.8	3-20 5056	16.5	SLE 3010 LVC	RT	4151 3829 min	3	face skin bearing	-
FPDE1 SK-8552-F													

F.9.2.4 Allowable bending moment

The results for bending tests are summarised in Table F-19.

Table F-19: Case study: SILEX - Allowable bending moment

Insert		Face sheets				Core		Potting	BENDING Test data				
		Upper		Lower					Temp (°C)	Average value (Nm)	No. of samples	Failure mode	Note
dia. (mm)	height (mm)	material	thickness (mm)	material	thickness (mm)	material	height (mm)						
14	15	CFRP: M55J isotropic lay-up	0.8	CFRP: M55J isotropic lay-up	0.8	3-20 5056	16.5	SLE 3010 LVC	RT	39 26 min	3	face skin bearing	-
Shurlok SL10068 M5-3-S													
14	18.1	CFRP: M55J isotropic lay-up	0.8	CFRP: M55J isotropic lay-up	0.8	3-20 5056	16.5	SLE 3010 LVC	RT	44 39 min	3	face skin bearing	-
Sub-flush through insert (See: diag)													
14	18.1	CFRP: M55J isotropic lay-up	0.8	CFRP: M55J isotropic lay-up	0.8	3-20 5056	16.5	SLE 3010 LVC	RT	45 44 min	2	face skin bearing	-
Over-flush through insert (See: diag)													

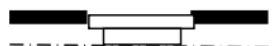

Sub-flush

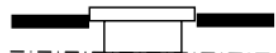

Over-flush



F.9.2.5 Allowable torsion moment

The results for torsion tests on a standard insert are summarised in Table F-20. Torque is applied to the insert with a screw.

NOTE Only a minimum value is given.

Table F-20: Case study: SILEX - Allowable torsion moment

Insert		Face sheets				Core		Potting	TORSION Test data				
dia. (mm)	height (mm)	Upper		Lower		material	height (mm)		Temp (°C)	Average value (Nm)	No. of samples	Failure mode	Note
14	15	material	thickness (mm)	material	thickness (mm)	material	height (mm)						
Shurlok SL10068 M5-3-S		CFRP: M55J isotropic lay-up	1.6	CFRP: M55J isotropic lay-up	1.6	4-20 5056	55.7	SLE 3010 LVC	RT	not stated 20.3 min	3	screw failure (class 12-9)	-

F.10 HRG

HRG '*Haute Résolution Géométrique*' is the main payload of SPOT 5. The structure is similar to HRV and HRV-IR on SPOT 3 and SPOT 4, respectively.

Special aluminium alloy inserts were potted into sandwich panels having CFRP composite face skins and an aluminium alloy honeycomb core.

F.10.1 Materials and configuration

Table F-21 lists materials and a configuration example.

F.10.2 Testing

F.10.2.1 Tensile load

Table F-22 summarises results of insert pull-out tests using the test method shown in Figure F-22.

NOTE Test data is from the HRV project (1983).

Table F-21: Case study: HRG – Materials and configuration

Project	HRG CL
Application	Electronic equipment
Insert:	[See: Figure F-21]
Type	Special Partially potted, with collar
Ref.	-
Position (1)	+0.1 –0
Material	Aluminium 2024-T351
Surface treatment	Alodine® 1200
Thread	Stainless, non-locking
Lubrication	Nuflon (titanium fixings)
Potting:	SLE 3010 LVC
Bonding: (2)	EC 2216
Sandwich panel:	
Face sheets	CFRP Thickness: 2 mm or 3 mm
Core	5056 4-40 perforated. Height: 43 mm
NOTE (1) With respect to surface.	
NOTE (2) Collar adhesively bonded to sandwich panel face sheet.	

VUE DE DESSOUS SANS CAPSULE

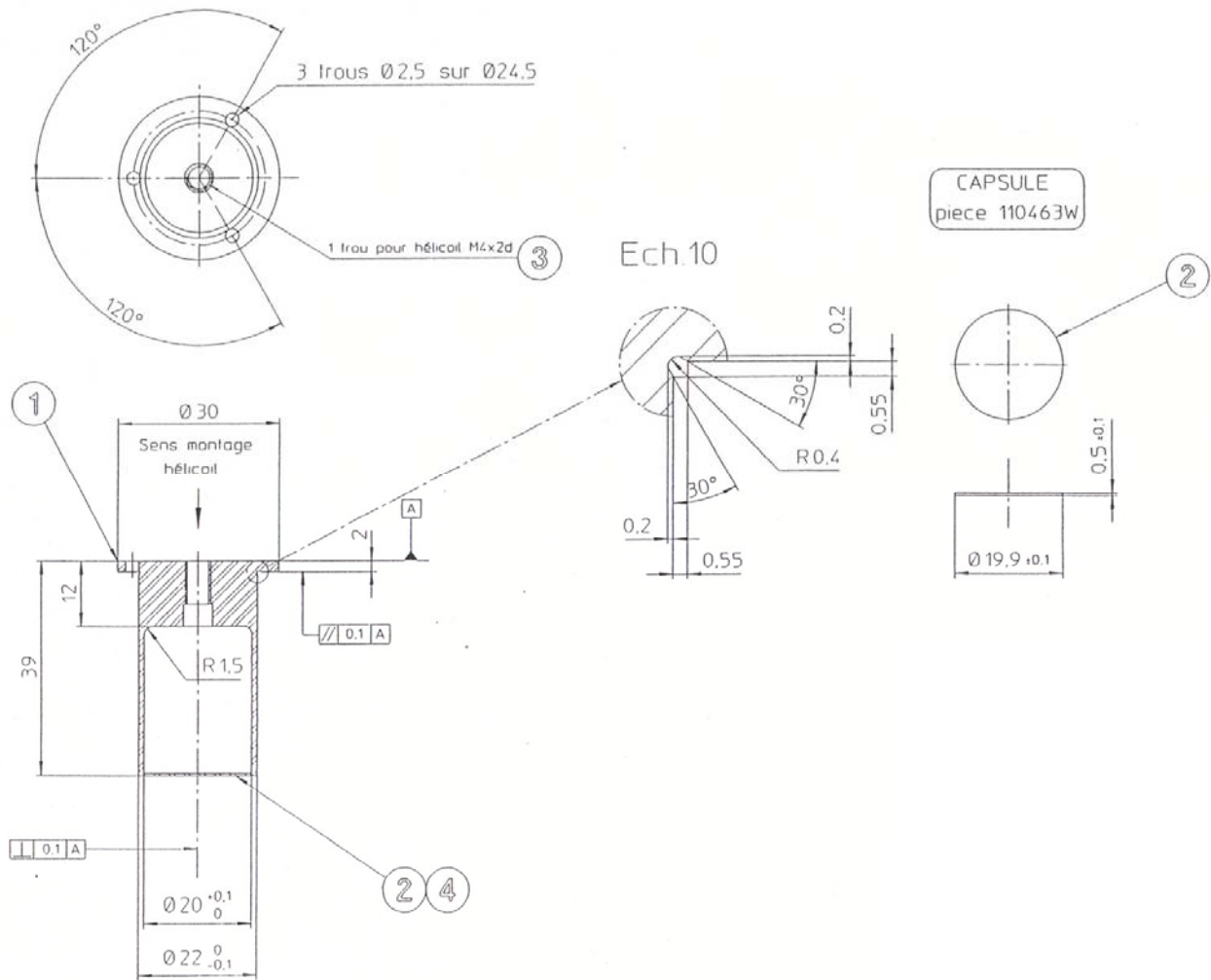
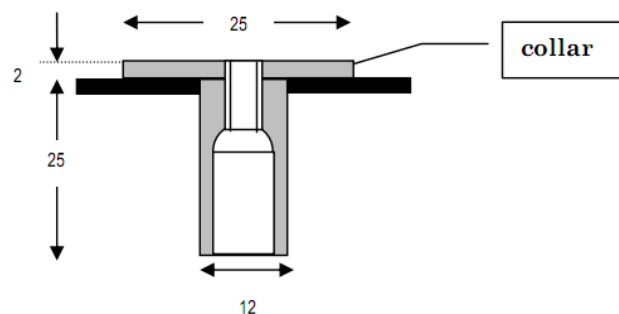

Figure F-21: Case study: HRG - Insert

Table F-22: Case study: HRG - Tensile load

Insert		Face sheets				Core		Potting	TENSILE Test data (4)				
		Upper		Lower					Temp (°C)	Average value (N)	No. of samples	Failure mode	Note
dia. (mm)	height (mm)	material	thickness (mm)	material	thickness (mm)	material	height (mm)						
-	-												
Special (1): Partially potted, collar.		CFRP: GY70/934 4 ply (0/+45/-45/0)	-	CFRP: GY70/934 4 ply (0/+45/-45/0)	-	9-48 AG5	43	SLE 3010 EC2216	-	4936 3050 min 1051 SD	28	not stated	(1) (2) (3)



- NOTE (1) Matra Marconi Space MMS Insert Ref: A-30A11-621 344 G.
- NOTE (2) Collar bonded to face sheet with EC2216.
- NOTE (3) Face sheet-to-core bonded with BSL 312L.
- NOTE (4) min: minimum; SD: standard deviation.

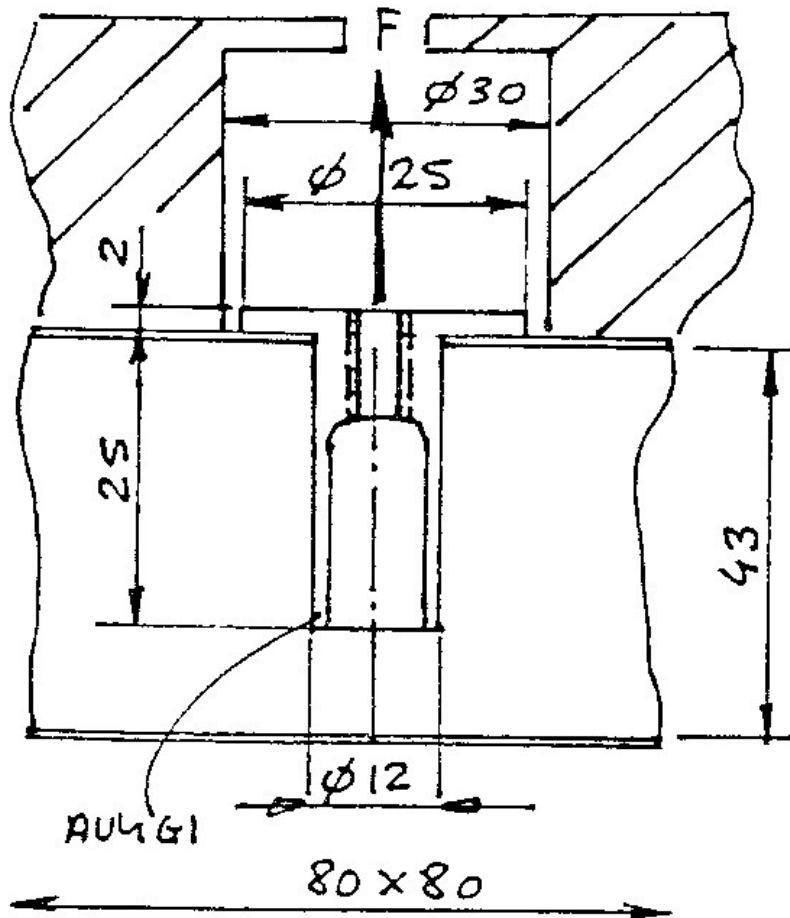

Figure F-22: Case study: HRG - Test method

F.11 NILESAT

Standard Shur-lok® and special aluminium alloy inserts potted into sandwich panels with aluminium alloy face sheets and honeycomb core.

F.11.1 Materials and configuration

Table F-23 lists materials and configuration examples.

F.11.2 Testing

No details given, [29-29].

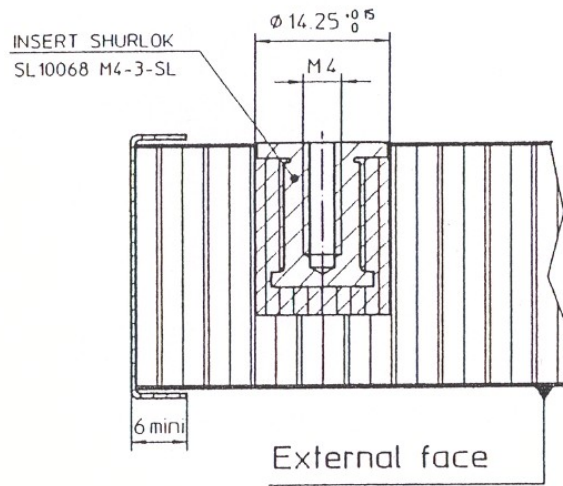

Table F-23: Case study: NILESAT – materials and configuration

Project	NILESAT Battery 1	NILESAT Battery 2
Application	Structure; panel assembly; satellite I/F.	Structure; handling.
Insert:	[See: Figure F-23]	[See: Figure F-24]
Type	Standard Partially potted	Special ⁽²⁾ Fully potted
Ref.	Shur-lok SL 10068	-
Position (1)	+0.1 / 0	-
Material	Aluminium 2024-T4	Aluminium 7075-T7351 Aluminium 7175-T7351
Surface treatment	Anodised MIL-A-8625	Alodine® 1200
Thread	Stainless, locking	Non-locking
Lubrication	Molicote (titanium fixings)	None (titanium fixings)
Potting:	SLE 3010 LVC	SLE 3010 LVC
Sandwich panel:		
Face sheets	Aluminium 6061 Thickness: 0.3 mm	Aluminium 6061 Thickness: 0.3 mm
Core	5056 4-28 perforated Height: not stated	5056 4-28 perforated Height: 25 mm
NOTE (1) With respect to surface.		
NOTE (2) From TELECOM 2		

Section C-C

Scale: 2/1



Section D-D

Scale: 2/1

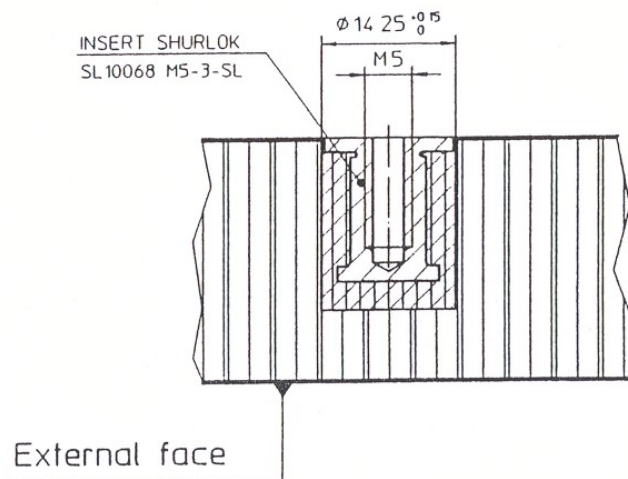

Figure F-23: Case study: NILESAT battery 1

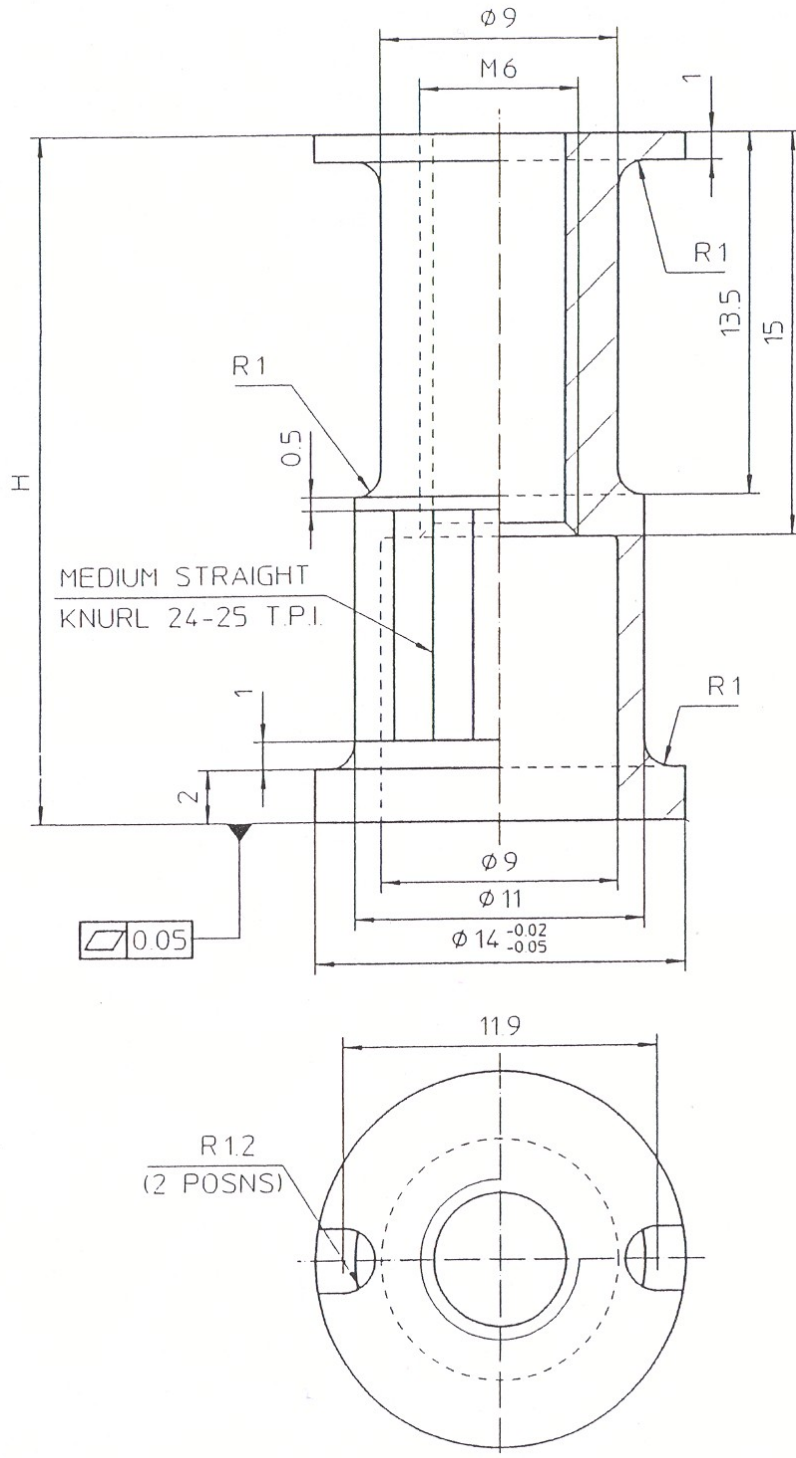

Figure F-24: Case study: NILESAT battery 2

F.12 EXAMPLE: Insert verification

F.12.1 Mounting

A box is mounted on a sandwich panel using inserts at the four corners, as shown in Figure F-25.

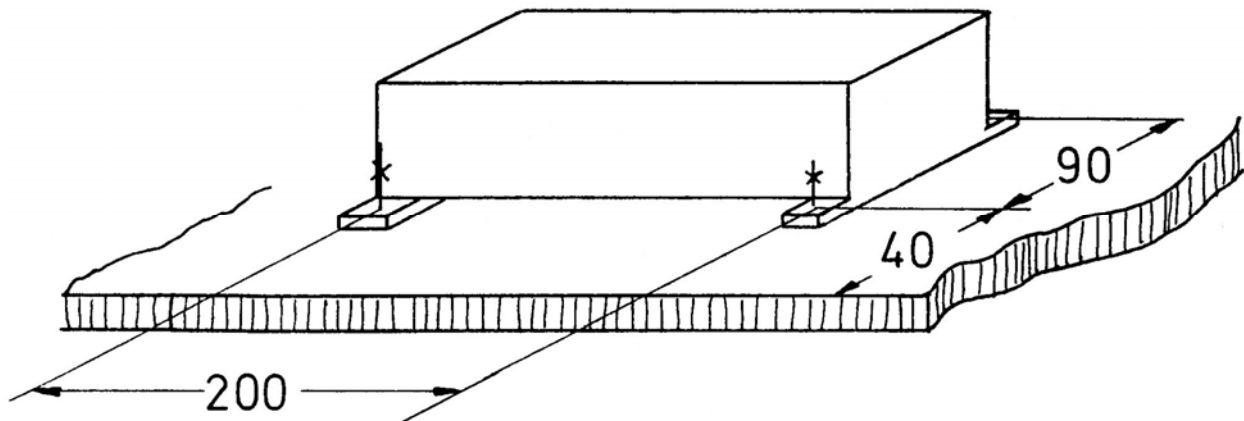

Figure F-25: Example: Insert verification – dimensions

F.12.2 Materials and configuration

The type of sandwich panel, box mass and loading conditions are:

- Sandwich panel:
 - core: aluminium alloy type 3/16-5052-.0007;
 - core height, c : 30 mm;
 - face sheet: 0.3 mm aluminium alloy.
- Mass of the box: 11 kg
- Acceleration⁽¹⁾: 20 g in all axes
- Temperature: ambient

NOTE (1) For simplification, the acceleration is assumed to act in the centre of plane of the face sheet.

F.12.3 Loads

F.12.3.1 Total load

$$F_r = m \times 20 \times 9.81 = 2200 \text{ N}$$

F.12.3.2 Ultimate load on each box corner

$$P_{ult} = \frac{F_i \times 1.5}{4} \quad 4 \text{ bolts} \quad [\text{See: 12.4}]$$

$$P_{ult} = \frac{2200 \times 1.5}{4} = 825 \text{ N}$$

F.12.4 Insert selection

NOTE See also: Annex B.

F.12.4.1 Tension

$$P_{SS} (b_i = 11) = 1090 \text{ N} \quad [\text{See: 12.5; B.1}]$$

$$P_{SS} (b_i = 14) = 1220 \text{ N} \quad [\text{See: 12.5; B.1}]$$

F.12.4.2 Compression

$$P_{SS} (d_i = 11) = 900 \text{ N} \quad [\text{See: 13.2; B.1}]$$

$$P_{SS} (d_i = 14) = 1050 \text{ N} \quad [\text{See: 13.2; B.1}]$$

NOTE Where the compressive strength is insufficient, increasing the foot diameter to exceed the potting element $2b_p$ can avoid using a larger insert.

F.12.5 In-plane loads

$$Q_{SS} = 8b_p^2 \tau_{wcrit} + 2b_p f \sigma_{fy} \quad \text{Eqn. [14.2-1]}$$

With:

$$b_{pmin} = 0.93192 b_i + 0.874 S_C - 0.66151 \quad \text{Eqn. [7.3-1]}$$

$$b_{pmin} (d_i = 11) = 8.63 \text{ mm} \quad [\text{See: Table 12-2}]$$

$$b_{pmin} (d_i = 14) = 10.03 \text{ mm}$$

And:

$$\tau_w = 0.32 \text{ N/mm}^2 \quad [\text{See: Table 6-3}]$$

$$f = 0.3 \text{ mm}$$

$$\sigma_{fy} = 270 \text{ N/mm}^2 \quad [\text{See: 6.6}]$$

$$\text{For } (d_i = 11): \quad Q_{SS} = 8 \times 8.63^2 \times 0.32 + 2 \times 0.3 \times 8.63 \times 270$$

$$= 1589 \text{ N}$$

$$\text{For } (d_i = 14): \quad Q_{SS} = 8 \times 10.03^2 \times 0.32 + 2 \times 0.3 \times 10.03 \times 270$$

$$= 1882 \text{ N}$$

NOTE The allowables exceed by far the requirements.

F.12.6 Grouping effects

See also: Clause 19.

F.12.6.1 Potting radius

The potting radius b_{pmin} was identified as:

- For ($d_i = 11\text{mm}$): 8.63 mm
- For ($d_i = 14\text{mm}$): 10.03 mm

with: $b_{p1} = b_{p2} \rightarrow \frac{b_{p1}}{b_{p2}} = 1$

F.12.6.2 Interference coefficient

The interference coefficient η_{is} becomes:

For ($d_i = 11$):

$$\eta_{is} = \eta_{is \frac{a}{b_{p1}}} = 1; \frac{b_{p1}}{b_{p2}} = 1 = 10.4$$

For ($d_i = 14$):

$$\eta_{is} = \eta_{is \frac{a}{b_{p1}}} = 0.9; \frac{b_{p1}}{b_{p2}} = 1 = 0.95$$

where:

$a = 90$ mm (in accordance with Figure 19-1)

NOTE The distance in the longitudinal direction exceeds $10b_{p1}$, so there is no interference effect here.

F.12.7 Edge influence

NOTE See also: Clause 18. The smallest distance of the outer insert to the free edge is:

$$l = 40 \text{ mm.}$$

This results in a ratio, [See: Clause 18]:

$$\text{For } (d_i = 11): \quad \frac{l}{b_p} = \frac{40}{8.63} \cong 4.6$$

$$\text{For } (d_i = 14): \quad \frac{l}{b_p} = \frac{40}{10.03} \cong 4.0$$

and:

$$\text{For } (d_i = 11): \quad \eta_{EN} = 0.95$$

$$\text{For } (d_i = 14): \quad \eta_{EN} = 0.90$$

F.12.7.1 Total tensile load capability

Total load capability under tension:

$$\text{For } (d_i = 11): \quad P_{max} (11\varnothing) = 1090 \times 1 \times 0.95 \approx 1035 \text{ N}$$

$$\text{For } (d_i = 14): \quad P_{max} (14\varnothing) = 1220 \times 0.85 \times 0.9 \approx 1043 \text{ N}$$

NOTE Both are acceptable.

F.12.8 Life of inserts

NOTE $d_i = 11$ mm, [See: 21.1] The maximum load during operation is:

$$F_{worst} = \frac{2200}{4} = 550 \text{ N (amplitude)}$$

The mean ratio, with $F_A = |\hat{F}|$:

$$R = \frac{|\hat{F}|^{-2F_A}}{|\hat{F}|} = \frac{|\hat{F}|^{-2}|\hat{F}|}{|\hat{F}|} = -1$$

The corrections for the actual geometry are:

- $h_c = 30$ mm,
- $f = 0.3$.

$$\left. \begin{array}{l} F_{EF} = 1.2766 \\ F_{pp} = 1.1052 \end{array} \right\} F_{c-f} \times F_{pp} = 1.411$$

F.12.8.1 Peak load

Assuming the sinusoidal vibration test at qualification as having a safety factor of 1.33, this can result in a peak load:

$$\hat{F} = F_{cc} \times 1.33 = \frac{2200}{4} \times 1.33 = 722 \text{ N}$$

The tolerable loads are 1.411 times higher than that shown in 21.5 (here $b_i = 11$ mm), which gives:

F_{plot} [N]	$F_{tol} = (F_{plot} \times 1.411)$	N [Cycle]
600	846	1200
500	705	6500
400	565	50000

Considering the sweep rate, the number of cycles occurring during sweep through the eigenfrequency is determined by:

$$N_0 = f_e \times \Delta t$$

Where:

$$\Delta t = \text{time to pass through the bandwidth, BW.}$$

With a scatter factor of 4, it has to be shown that:

$$N \geq 4 - N_0$$

NOTE Based upon the test conditions, the options are to either:

- accept an insert diameter of $2b_i = 11$ mm;
- repeat the fatigue check using an insert diameter of 14 mm.

F.13 References

F.13.1 General

- [29-29] 'Matra Marconi Space Contribution to ESA Insert Design Handbook'; MMS Ref. NT/102/BG/355013.96 (Dec. 1996)
- [29-30] ROSETTA Lander Subsystem Specification - Structure
RO-LST-SP-3601, Issue 4/0, para. 2.2.4 (2001)
- [29-31] Test Procedure – Insert Qualification Tests for the ROSETTA Lander.
DASA document QTIN-RST-TPR-0001 (1998)
- [29-32] Test Report – Insert Qualification Tests for the ROSETTA Lander. DASA
document QTIN-RST-TR-0001 (1998)
- [29-33] J. Block, R. Schütze, T. Brander, K. Marjoniemi, L. Syvänen, M. Lambert:
DLR Braunschweig / Helsinki Univ. Technology / Patria / ESTEC
'Study on Carbon Fibre Tube Inserts'
ESTEC Contract No. 16822/02/NL/PA, 2004
- [29-34] ESA-PSS-03-1202 (Issue 1, Revision 1) September 1990: 'Insert design
handbook'

Annex G Formulae

G.1 Introduction

Excluding those in Annexes, a list of all the mathematical formulae and expressions stated throughout the handbook are given here. These are provided without explanation and are intended for handbook users creating their own calculation software. [See also: G.2 for nomenclature].

Each equation is referenced by the equation number used in the handbook and hyperlinked to the relevant section, e.g.:

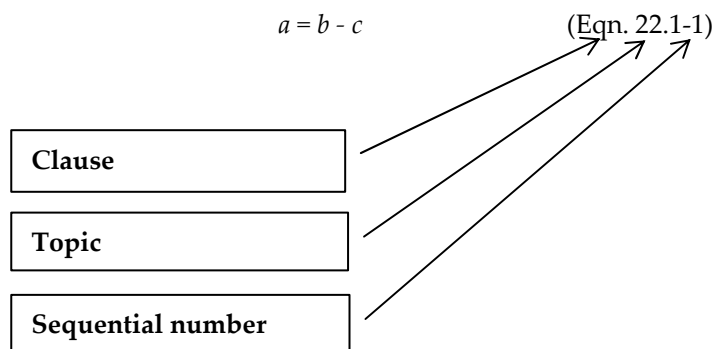

G.2 Nomenclature

a	<i>centre-to-centre distance between inserts</i>
A	<i>one sixth of hexagonal cell circumference</i>
AA	<i>American Aluminium Association</i>
av	<i>average value</i>
B	<i>bending stiffness</i>
b_i	<i>insert radius</i>
b_p	<i>potting radius</i>
b_{pmin}	<i>minimum potting radius</i>
b_{ptyp}	<i>average or typical potting radius</i>
b_R	<i>real potting radius</i>
b_{Rtyp}	<i>average or typical real potting radius</i>
c	<i>core height</i>

C'	<i>correction factor for strength capabilities with heights of core, $c > 9\text{mm}$</i>
D	<i>foot diameter of an attached structural part</i>
d_i	<i>insert diameter (also = $2b_i$)</i>
d_p	<i>potting diameter</i>
e	<i>distance of insert from the sandwich panel edge</i>
E	<i>Young's modulus</i>
E_f	<i>Young's modulus of isotropic face sheet material</i>
E_R	<i>tensile modulus of potting compound</i>
E_{xy}	<i>Young's modulus of anisotropic face sheet material</i>
F	<i>applied inclined load</i>
f	<i>face sheet thickness when $f_1 = f_2$</i>
f_1	<i>thickness of upper facing sheet</i>
f_2	<i>thickness of lower facing sheet</i>
F_{ss}	<i>static strength capability under loads inclined to plane of facing</i>
G_C	<i>effective core shear modulus</i>
G_L	<i>shear modulus of core in L-direction</i>
<i>guar</i>	<i>guaranteed value</i>
G_W	<i>shear modulus of core in W-direction</i>
h_i	<i>insert height</i>
h_p	<i>potting height</i>
h_{pmin}	<i>minimum allowable potting height</i>
h_{ptyp}	<i>typical potting height</i>
K_t	<i>magnification factor due to fatigue</i>
K_{tpp}	<i>stress concentration factor due to partially potted inserts in non-metallic cores</i>
L	<i>longitudinal direction of a honeycomb core</i>
LN	<i>Luftfahrt-Norm (aeronautical standard)</i>
M_{ss}	<i>allowable bending moment related to static insert strength</i>
M	<i>bending moment</i>
<i>min</i>	<i>minimum value</i>
N	<i>newton</i>
n	<i>number of inserts in an insert group</i>
N_{PC}	<i>number of core cells filled with potting resin</i>
p	<i>load normal to plane of facing</i>
P^*_{ss}	<i>reduced static strength capability of an insert due to edge effects</i>

$p_{crit\ min}$	<i>insert load capability due to minimum properties of the components (core, facing, resin)</i>
$p_{crit\ typ}$	<i>insert load capability due to the typical properties of the components</i>
P_{SS}	<i>static strength capability of an insert under loads normal to plane</i>
$P_{ssc\ min}$	<i>minimum insert load carrying capability in compression</i>
$P_{sst\ av}$	<i>average insert load carrying capability in tension</i>
$P_{sst\ min}$	<i>minimum insert load carrying capability in tension</i>
Q	<i>resulting shear load</i>
Q^{*ss}	<i>reduced shear load for inserts near panel edges</i>
Q_C	<i>portion of Q taken by the core</i>
Q_{SS}	<i>allowable shear load</i>
R	<i>rear stress rate</i>
RC	<i>reliability coefficient</i>
RT	<i>room temperature</i>
S_c	<i>core cell size</i>
t_o	<i>core foil thickness</i>
T_{ss}	<i>allowable torsional load</i>
typ	<i>typical value</i>
W	<i>transverse direction of a honeycomb core</i>
x	<i>distance between facing sheet upper surface and insert upper flange surface</i>
α	<i>angle between insert load direction and facing plane</i>
γ_e	<i>density of the expanded core</i>
γ_o	<i>density of the material</i>
γ_R	<i>density of the potting resin</i>
η_{EN}	<i>edge coefficient of inserts loaded in tension or compression</i>
η_{EQ}	<i>edge coefficient of shear loaded inserts</i>
η_{IG}	<i>interference coefficient of a group of equidistant inserts</i>
η_{IC}	<i>interference coefficient of inserts loaded in opposite directions</i>
η_{IS}	<i>interference coefficient of two neighbouring inserts load capability reduction coefficient of two neighbouring inserts</i>
η_T	<i>coefficient of thermal degradation</i>
η_{TA}	<i>load capability reduction coefficient of insert exposed to elevated temperature</i>
η_{TC}	<i>load capability reduction coefficient of inserts exposed to thermal cycling</i>
η_{Tb}	<i>load capability reduction coefficient of insert at RT after 20 hours exposure to elevated temperature</i>
η_{TR}	<i>reduction coefficient of potting resin strength at elevated temperatures</i>
ν_f	<i>Poisson's ratio of isotropic facing sheet material</i>

$\nu_{x,y}$	<i>Poisson's ratio of anisotropic facing sheet material</i>
$\sigma_{c \text{ crit } c}$	<i>core strength in compression</i>
$\sigma_{c \text{ crit } t}$	<i>core strength in tension</i>
$\sigma_{c \text{ crit } c \text{ min}}$	<i>minimum compression strength of core</i>
$\sigma_{c \text{ crit } c \text{ typ}}$	<i>typical compression strength of core</i>
σ_{fy}	<i>yield strength of facing sheet material</i>
σ_{Rcrit}	<i>tensile strength of potting resin</i>
τ_c	<i>core shear strength</i>
$\tau_{c \text{ crit}}$	<i>core shear strength effective to insert strength (circular)</i>
$\tau_{c \text{ crit } \text{ min}}$	<i>minimum allowable core shear strength</i>
$\tau_{c \text{ crit } \text{ typ}}$	<i>typical or average core shear strength</i>
τ_{Lcrit}	<i>critical shear strength of core in L-direction</i>
τ_{Rcrit}	<i>shear strength of potting resin</i>
τ_{Wcrit}	<i>critical shear strength of core in W-direction</i>

G.3 List of mathematical formulae

[See: G.1 for links; G.2 for nomenclature]

G.3.1 Clause 6 Sandwich panels

$$B = \frac{E_f f^3}{12(1-\nu_f^2)} \quad [6.2-1]$$

$$f_{Al} = f_{an} \sqrt[4]{\frac{\sqrt{E_x E_y} (1-\nu_{Al}^2)}{E_{Al} (1-\nu_x \nu_y)}} \quad [6.2-2]$$

$$G_C = G_W / 3 \quad [6.4-1]$$

$$\tau_{c \text{ crit}} = 1.36 \tau_{w \text{ crit}} \quad [6.5-1]$$

$$\sigma_{c \text{ crit } t} = \sigma_{0 \text{ crit } t} \gamma_c / \gamma_0 \quad [6.6-1]$$

$$\sigma_{c \text{ crit } t \text{ min}} = 0.9 \sigma_{0 \text{ crit } t} \gamma_c / \gamma_0 \quad [6.6-2]$$

$$\sigma_{c\text{critt min}} = 0.9 \sigma_{0\text{crit c typ}} \quad [6.6-3]$$

G.3.2 Clause 7 Embedding of inserts

$$b_p = \frac{1}{n} \sum b_n \quad [7.3-1]$$

$$b_{p\text{min}} = 0.93192 b_i + 0.874 S_c - 0.66151 \quad [7.3-2]$$

$$b_{p\text{min}} = 0.9 b_i + 0.7 S_c \quad [7.3-3]$$

$$b_{p\text{typ}} = 1.002064 b_i + 0.940375 S_c - 0.7113 \quad [7.3-4]$$

$$b_{p\text{typ}} = b_i + 0.8 S_c \quad [7.3-5]$$

$$b_R = \sqrt{\frac{F_R}{\pi}} = \sqrt{\frac{N_{PC} F_C}{\pi}} \quad [7.4-1]$$

$$F_c = 0.95 \times 0.75 \times S_c^2 \cos \alpha \quad [7.4-2]$$

$$b_R = b_i + 0.35 S_C \quad [7.4-3]$$

$$b_{R\text{typ}} = b_i + 0.5 S_C \quad [7.4-4]$$

$$h_p = c \text{ for } c \geq h_i \geq c - 7 \text{ mm} \quad [7.5-1]$$

$$h_{p\text{min}} = h_i + 7 \text{ mm} \quad [7.5-2]$$

$$h_{p\text{typ}} = h_{p\text{min}} + A \operatorname{tgh} \left(\frac{c - h_{p\text{min}}}{h_{p\text{min}}} \right) \quad [7.5-3]$$

$$\text{Mass of face-sheet hole} = f b_i^2 \pi p \quad [7.6-1]$$

G.3.3 Clause 8 Mechanics of sandwich structures

$$w = w_b + w_s \quad [8.1-1]$$

$$\frac{d^2 w}{dx^2} = -\frac{M}{D} \Rightarrow \quad [8.1-2]$$

$$w_b = -\iint \frac{M}{D} dx dx + C_1 x + C_2$$

$$D = b \left[E_f \left\{ \frac{f^3}{6} + \frac{f(c+f)^2}{2} \right\} + E_c \frac{c^3}{12} \right] \quad [8.1-3]$$

$$D \approx E_f \frac{bf(c+f)^2}{2} \quad \text{For } f \ll c \text{ and } E_f \gg E_c \quad [8.1-4]$$

$$\gamma_0 = \frac{u_{upper} - u_{lower}}{c} \quad [8.1-5]$$

$$\frac{dw_s}{dx} = (\gamma - \gamma_0) \frac{c}{(c+f)} \quad [8.1-6]$$

$$\gamma = \frac{\tau_c}{G_c} = \frac{Q}{G_c(c+f)} \quad [8.1-7]$$

$$\frac{dw_s}{dx} = \frac{Q}{S} - \frac{\gamma_0 c}{(c+f)} \Rightarrow \quad [8.1-8]$$

$$w_s = \frac{M}{S} - \frac{\gamma_0 cx}{(c+f)} + C_3$$

$$S = G_c \frac{(c+f)^2}{c} \quad [8.1-9]$$

$$\sigma_{xf} = \frac{Mz}{D} E_f \text{ where } \begin{cases} \frac{c}{2} + f \geq z \geq \frac{c}{2} \\ -\frac{c}{2} \geq z \geq -(\frac{c}{2} + f) \end{cases} \quad [8.1-10]$$

$$\sigma_{xc} = \frac{Mz}{D} E_c \text{ where } \frac{c}{2} \geq z \geq -\frac{c}{2}$$

$$\tau_c = \frac{Q}{b(c+f)}$$

G.3.4 Clause 10 Design considerations

$$P_{\text{allowable}} \geq P_{\text{ult}} = P_{\text{limit}} J_n \quad [10.6-1]$$

$$F_y = F_{\text{lim}} \times SF_{\text{add}} \times J_E \quad [10.6-2]$$

$$F_u = F_{\text{lim}} \times SF_{\text{add}} \times J_R \quad [10.6-3]$$

$$F_{\text{all}} = \sigma_{\text{bearingall}} \times t \times \phi \quad [10.8-1]$$

$$F_{\text{add}} = \tau_{\text{all}} \times S_{\text{bonding}} \quad [10.8-2]$$

$$F_{\text{all}} = 2 \times d \times t \times \tau_{\text{all}} \quad [10.8-3]$$

$$F_{\text{all}} = \tau_{\text{all}} \times h \times \pi D \quad [10.8-4]$$

G.3.5 Clause 12 Tensile strength

$$P_f = \frac{P_{sy}}{2-b_p c} \quad [12.1-1]$$

$$\tau(r) = \frac{P I_p}{\pi(h+c)I} \times \left(\frac{1}{r} - \frac{I_1(\alpha r)}{a b_p} \frac{b_p K(\alpha b_p) - a K_1(\alpha a)}{I_1(\alpha a) \times K_1(\alpha b_p) - I_1(\alpha b_p) \times K_1(\alpha a)} - \frac{K_1(\alpha r)}{a b_p} \frac{a I_1(\alpha a) - b_p I_1(\alpha b_p)}{I_1(\alpha a) \times K_1(\alpha b_p) - I_1(\alpha b_p) \times K_1(\alpha a)} \right) \quad [12.2-1]$$

$$I_p = \frac{t_{s1} t_{s2} (h+c)^2}{4(h-c)} \quad [12.2-2]$$

$$I_s = \frac{t_{s1}^3 + t_{s2}^3}{12} \quad [12.2-3]$$

$$\alpha = \sqrt{\frac{G_c (h-c) I}{E c t_{s1} t_{s2} I_s}} \quad [12.2-4]$$

$$E = \frac{E_s}{1 - \nu_s^2} \quad [12.2-5]$$

$$RC = 1.172 - 0.0063 \times c - 0.2641 \times f \quad [12.3-1]$$

$$RC = 1.207 - 0.00544 \times c - 0.2088 \times f \quad [12.3-2]$$

$$C^{I*} = C^I + h_i^* - h_i \quad [12.6-1]$$

$$E = \sqrt{E_x E_y} \quad [12.7-1]$$

$$\nu = \sqrt{\nu_{xy} \nu_{yx}} \quad [12.7-2]$$

G.3.6 Clause 13 Compressive strength

$$P_{SS c min} = RC P_{crit min} \quad [13.1-1]$$

$$P_{SS\ c\ av} = RC P_{crit\ av} \quad [13.1-2]$$

G.3.7 Clause 14 Shear strength

$$D \geq 2b_p \approx 2(b_t + 4\text{ mm}) \quad [14.1-1]$$

$$Q_c = 8b_p^2 \tau_{W\ crit} \quad [14.1-2]$$

$$Q_{SS} = 8b_p^2 \tau_{W\ crit} + 2fb_p \sigma_{fy} \quad \text{for } b_p \leq 11\text{ mm} \quad [14.2-1]$$

$$Q_{Stt_symm.} = 2(2t_s b_p \sigma_{sy}) \quad [14.3-1]$$

$$Q_{Stt_unsymm.} = 2t_s b_p \sigma_{sy} \quad [14.3-2]$$

$$Q_c = 8b_p^2 \tau_{Wcrit} \quad [14.3-3]$$

$$Q_S = 8b_p^2 \tau_{Wcrit} + 2t_s b_p \sigma_{sy} \quad [14.3-4]$$

$$Q_t \leq \frac{1}{K_e} (w - b_t) t_s \sigma_{t,ult} \quad [14.3-5]$$

$$Q_s \leq 2t_s \left(e - \frac{b_t}{2} \right) \frac{1}{\cos \alpha} \tau_s \quad [14.3-6]$$

$$Q_d \leq \frac{2}{\pi} b_p t_s K_D \frac{E_s}{1 - \nu_s^2} \left(\frac{t_s}{S_c} \right)^2 \quad [14.3-7]$$

$$Q_b \leq K_b \frac{2}{\pi} b_t t_s \sigma_{comp} \quad [14.3-8]$$

$$Q_{crit}^* = Q_{crit} \eta_{EQ} \quad [14.3-9]$$

$$\eta_{EN} = 0.66 \sqrt{\frac{e}{b_p}} - 0.06 \frac{e}{b_p} \quad \text{for } e \leq 3b_p \quad [14.3-10]$$

$$\text{and: } \eta_{EN} = 1 \text{ for } e > 3b_p$$

$$Q_S = 8b_p^2 \tau_{Wcrit} + 2t_s b_p \sigma_{sy} \quad [14.3-11]$$

G.3.8 Clause 15 Bending strength

$$M_{ss} = P_{SSc} b_i \quad [15.2-1]$$

$$M_{crit} = P_{crit} b_i \quad [15.3-1]$$

G.3.9 Clause 16 Torsional strength

$$T_{SS} = 4\pi b_R^2 t_0 \tau_{0crit} \quad [16.2-1]$$

$$T_{crit} = 4\pi b_R^2 t_0 \tau_{0crit} \quad [16.3-1]$$

G.3.10 Clause 17 Combined loads

$$\left(\frac{P}{P_{SS}}\right)^2 + \left(\frac{Q}{Q_{SS}}\right)^2 \leq 1 \quad [17.1-1]$$

$$|F_{SS}| = \frac{P_{SS} Q_{SS}}{\sqrt{P_{SS}^2 \cos^2 \alpha + Q_{SS}^2 \sin^2 \alpha}} \quad [17.1-2]$$

$$\left(\frac{P}{P_{SS}}\right)^2 + \left(\frac{Q}{Q_{SS}}\right)^2 + \left(\frac{M}{M_{SS}}\right)^2 + \left(\frac{T}{T_{SS}}\right)^2 \leq 1 \quad [17.2-1]$$

G.3.11 Clause 18 Edge influence

$$P_{SS}^* = P_{SS} \eta_{EN} \quad [18.1-1]$$

$$\begin{aligned} \eta_{EN} &= 0.55 \sqrt{\frac{e}{b_p}} - 0.05 \frac{e}{b_p} && \text{for } e \leq 5b_p \\ \eta_{EN} &= 1 && \text{for } e > 5b_p \end{aligned} \quad [18.1-2]$$

$$Q_{SS}^* = Q_{SS} \eta_{EQ} \quad [18.2-1]$$

$$\begin{aligned} \eta_{EQ} &= 0.66 \sqrt{\frac{e}{b_p}} - 0.06 \frac{e}{b_p} && \text{for } e \leq 3b_p \\ \eta_{EQ} &= 1 && \text{for } e > 3b_p \end{aligned} \quad [18.2-2]$$

G.3.12 Clause 19 Insert groups

$$P_{SS1}^* = \eta_{IS1} P_{SS1} \quad [19.1-1]$$

$$a \leq 5(b_{p1} + b_{p2}) \quad [19.1-2]$$

$$\eta_{IS1} = \frac{\frac{b_{p1}}{b_{p2}}}{1 + \frac{b_{p1}}{b_{p2}}} \left(1 + \frac{a}{5b_{p1}} \frac{1}{1 + \frac{b_{p1}}{b_{p2}}} \right) \quad [19.1-3]$$

$$\eta_{IS1} = \eta_{IS2} = 1 \quad \text{for } a > 5(b_{p1} + b_{p2}) \quad [19.1-4]$$

$$\eta_{IS2} = \frac{\left(\frac{b_{p1}}{b_{p2}}\right)^{-1}}{1 + \left(\frac{b_{p1}}{b_{p2}}\right)^{-1}} \left(1 + \frac{a}{5b_{p1}} \left[\frac{b_{p1}/b_{p2}}{1 + \left(\frac{b_{p1}}{b_{p2}}\right)^{-1}} \right] \right) \quad [19.1-5]$$

$$P_{SS2}^* = \eta_{IS2} P_{SS2} \quad [19.1-6]$$

$$\eta_{IS1}^1 = 1 - \left(1 - \eta_{IS1}\right) \frac{P_2}{P_{SS2}^*} \quad [19.1-7]$$

$$P_{SS}^* = P_{SS} \eta_{IC} \quad [19.2-1]$$

$$P_{SSi}^* = P_{SSi} (\eta_{ISl} + \eta_{ISr} - 1) \quad [19.3-1]$$

$$a' \geq 5(b_{pi} + b_{pi\pm 2}) \quad [19.3-2]$$

$$P_{SS1}^* = P_{SS1} \eta_{IS1} \eta_{IC} \quad [19.4-1]$$

$$P_{SSi}^* = P_{SSi} (\eta_{ISl} + \eta_{ISr} - 1) \eta_{IC} \quad [19.4-2]$$

$$\eta_{IC} = \begin{cases} = 0.9 & \text{for } a \leq 5(b_{pi1} + b_{pi2}) \\ = 1.0 & \text{for } a > 5(b_{pi1} + b_{pi2}) \end{cases} \quad [19.4-3]$$

$$P_{SS}^* = \eta_G P_{SS} \quad [19.5-1]$$

$$\eta_G = 2 \left(\frac{n-1}{n} \eta_{IS} + \frac{1}{n} - 0.5 \right) \quad [19.5-2]$$

$$\eta_{IS} = 1/2 (1 + a/10b_p) \quad [19.5-3]$$

$$\eta_G = \eta_{IS} = 1 \quad \text{for } a > 10b_p \quad [19.5-4]$$

G.3.13 Clause 21 Fatigue

$$\tau_c = \frac{C^* K r_{\max}}{2\pi b_p c} F \quad [21.2-1]$$

$$\frac{\tau_{ccritmin}}{P_{SSmin}} = \frac{C^* K r_{\max}}{2\pi b_p c} \quad [21.2-2]$$

$$\tau_c = F \frac{\tau_{ccritmin}}{P_{SSmin}} \quad [21.2-3]$$

$$\begin{aligned} \tau_{cmin} &= \frac{0.57}{1290} p \\ &= 4.4 \times 10^{-4} \left[\frac{1}{\text{mm}^2} \right] p \end{aligned} \quad [21.2-4]$$

$$\tau_{c \text{ local}} = \tau_c K_t \quad [21.2-5]$$

$$K_t = \varepsilon \prod_{j=1}^s K_{tj} \quad [21.2-6]$$

Determining K_t fatigue stress concentration factors for various local stress effects, [See: Table 21-1]

$$\tau = \tau_{mean} + \tau_{1a} \sin(\omega t) \quad [21.3-1]$$

$$R = \frac{|\tau_{mean}| - \tau_A}{|\tau_{mean}| + \tau_A} \quad [21.3-2]$$

$$\hat{F} = \frac{2P_a}{1-R} \quad [21.3-3]$$

$$\hat{\tau} = \frac{2\tau_a}{1-R} \quad [21.3-4]$$

$$\tau_a = C N^{-\frac{1}{\kappa}} \text{ for } \tau_{mean} + \tau_A < \tau_{crit} \quad [21.5-1]$$

$$\tau_a = \left(\frac{2}{1-R} \right)^m C_A N^{-\frac{1}{\kappa}} \text{ for } \frac{\hat{\tau}}{K_t} < \tau_{crit} \quad [21.5-2]$$

$$\hat{\tau} = \left(\frac{2}{1-R} \right) \tau_a \quad [21.5-3]$$

$$\hat{\tau} = \left(\frac{2}{1-R} \right)^{m+1} C_A N^{-\frac{1}{\kappa}} \quad [21.5-4]$$

$$F = \frac{2\pi b_p^c}{C^* K_{rmax}} \tau_c \quad [21.5-5]$$

$$\hat{\tau}_c = \frac{\hat{\tau}}{K_t} \quad [21.5-6]$$

$$\hat{F} = \frac{2\pi b_p^c}{C^* K_{rmax} K_t} \left(\frac{2}{1-R} \right)^{m+1} C_A N^{-\frac{1}{\kappa}} \quad [21.5-7]$$

$$\tau_c = \frac{P_{ss}}{\tau_{crit}} \quad [21.5-8]$$

$$\hat{F} = \left(\frac{P_{SS}}{\tau_{ccritmin}} \right) \frac{1}{K_t} \left(\frac{2}{1-R} \right)^{m+1} C_A N^{-1/k} \quad [21.5-9]$$

$$\hat{F} = \frac{P_{SS}}{\tau_c} \left(\frac{h_p}{c} \right)^{0.8} \left(\frac{2}{1-R} \right)^{m+1} C_A N^{-1/k} \quad [21.5-10]$$

$$D_i = \sum \frac{n_i}{N_i} \leq k \quad [21.6-1]$$

G.3.14 Clause 22 Environmental effects

$$P_{\eta Ti} = P \times \eta_{Ti} \quad [22.2-1]$$

G.3.15 Clause 23 Manufacturing procedures

$$n_{\text{standard}} = 1 + \frac{N_{ges}}{100} \quad [23.6-1]$$

$$n_{\text{safetycrit}} = 2 + \frac{N_{ges}}{10} \quad [23.6-2]$$

G.3.16 Clause 28 Quality control

$$\text{Actual degree of (core) expansion} = \frac{\text{actual cell size}}{\text{nominal cell size}} \times 100 [\%] \quad [28.5-1]$$

$$\rho_N = K_{ex} \rho_{act} \quad [28.5-2]$$

Annex H

Insert test fixtures

H.1 Introduction

This annex contains the technical drawings of the four insert test fixtures for the standardised testing of 80 mm × 80 mm sandwich panel specimens with a central insert; as described in 27.3.

The four different test fixtures enable the application of:

- Out-of-plane loads (in tension or compression), [See: H.2];
- In-plane shear loads, [See: H.3];
- Bending moments, [See: H.4];
- Torsional moments, [See: H.5].

The fixtures are suitable for static test machines as well as for servo-hydraulic test machines, e.g. for fatigue loading.

The test fixtures were originally developed by DLR for the qualification of carbon fibre tube inserts, [29-35], but are also suitable for any other type of insert.

NOTE These DLR technical drawings are also provided in standard .DXF (drawing exchange file) format on the Insert design handbook CDROM, and can be imported into most commercially available CAD software.

[See: CDROM directory "Test Fixture DXFs"]

For insert/sandwich configurations with higher load-bearing capabilities a size of 80 mm × 80 mm for the samples and corresponding cover plates can be too small.

Under high out-of-plane forces, the remaining small support area of the cover plate outside the central 70 mm diameter hole can produce stress concentrations high enough to crush the honeycomb core. In this case, it is necessary to increase the sample and cover plate sizes to 100 mm × 100 mm or more. All other design features can remain unchanged.

H.2 Test fixture: Tension-Compression load

The tension-compression test fixture is described in 27.3, [See also: Figure 27-1 and Figure 27-2].

The set of engineering drawings for the test fixture are shown divided into several parts:

- Master drawing, in Figure H-1
- Part 1, in Figure H-2
- Part 2, in Figure H-3

H.2.1.2 Part 1

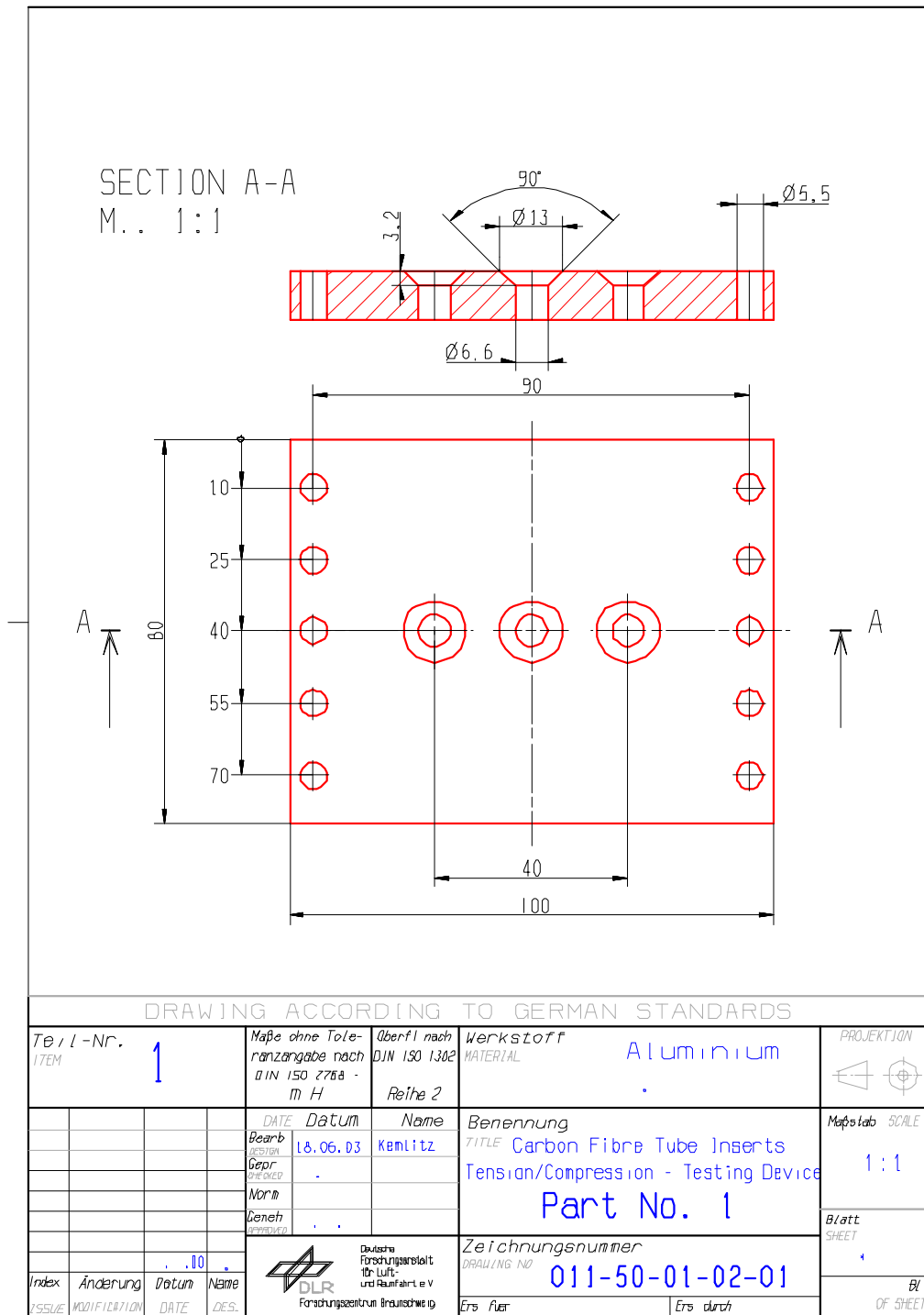

Figure H-2: Test fixture: Tension-compression load – part 1

H.2.1.3 Part 2

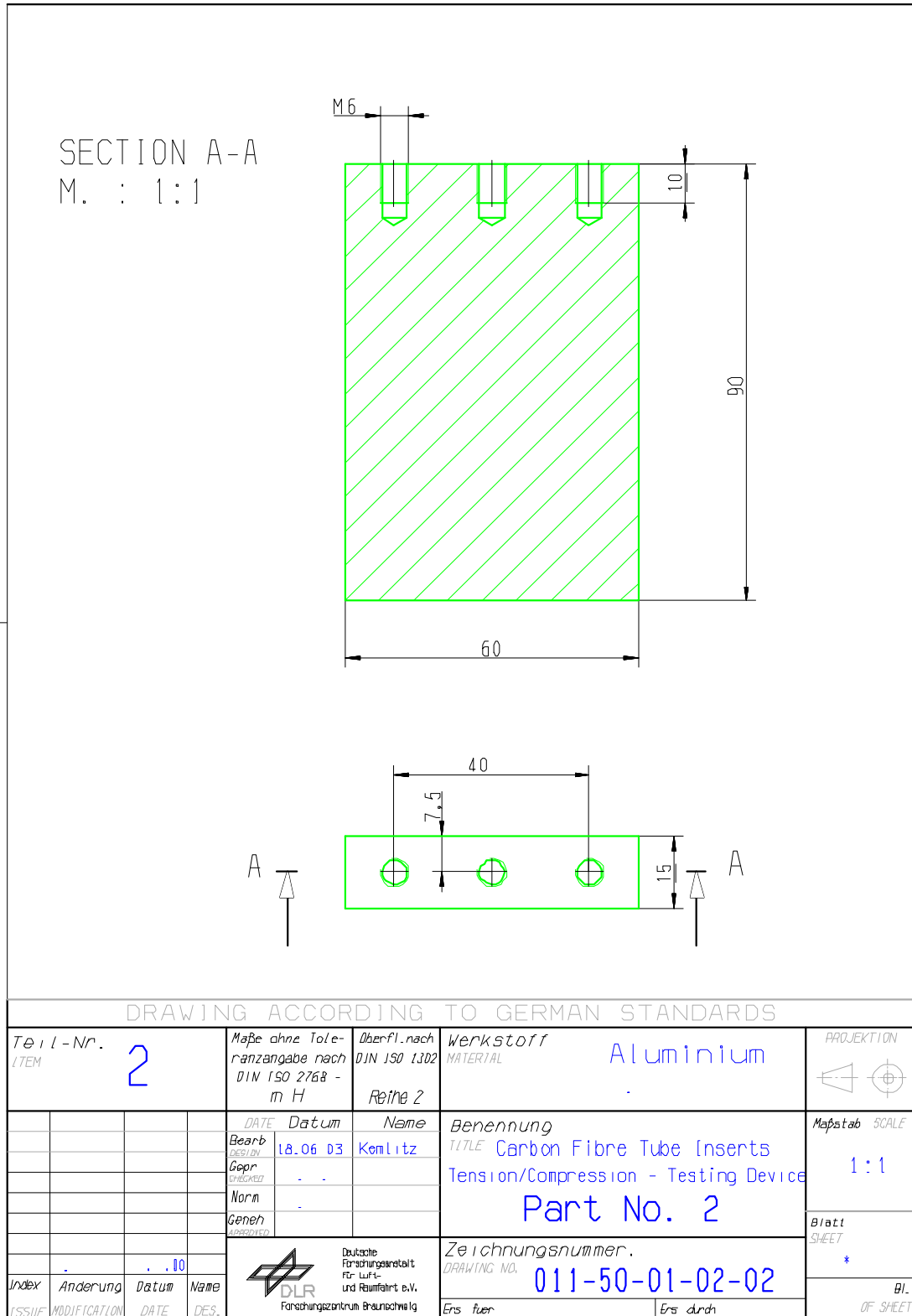

Figure H-3: Test fixture: Tension-compression load – part 2

H.2.1.4 Part 3

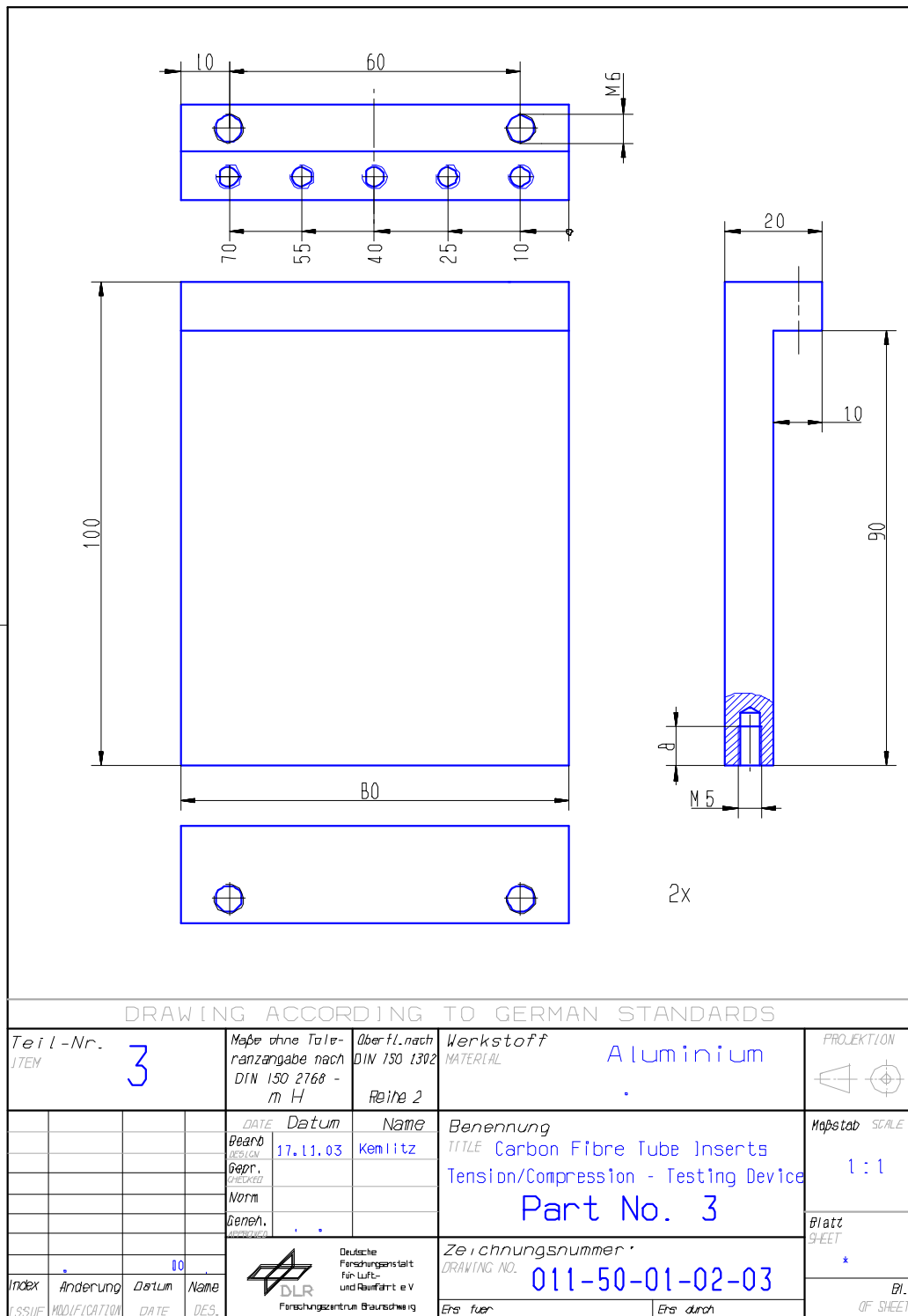

Figure H-4: Test fixture: Tension-compression load – part 3

H.2.1.5 Part 4

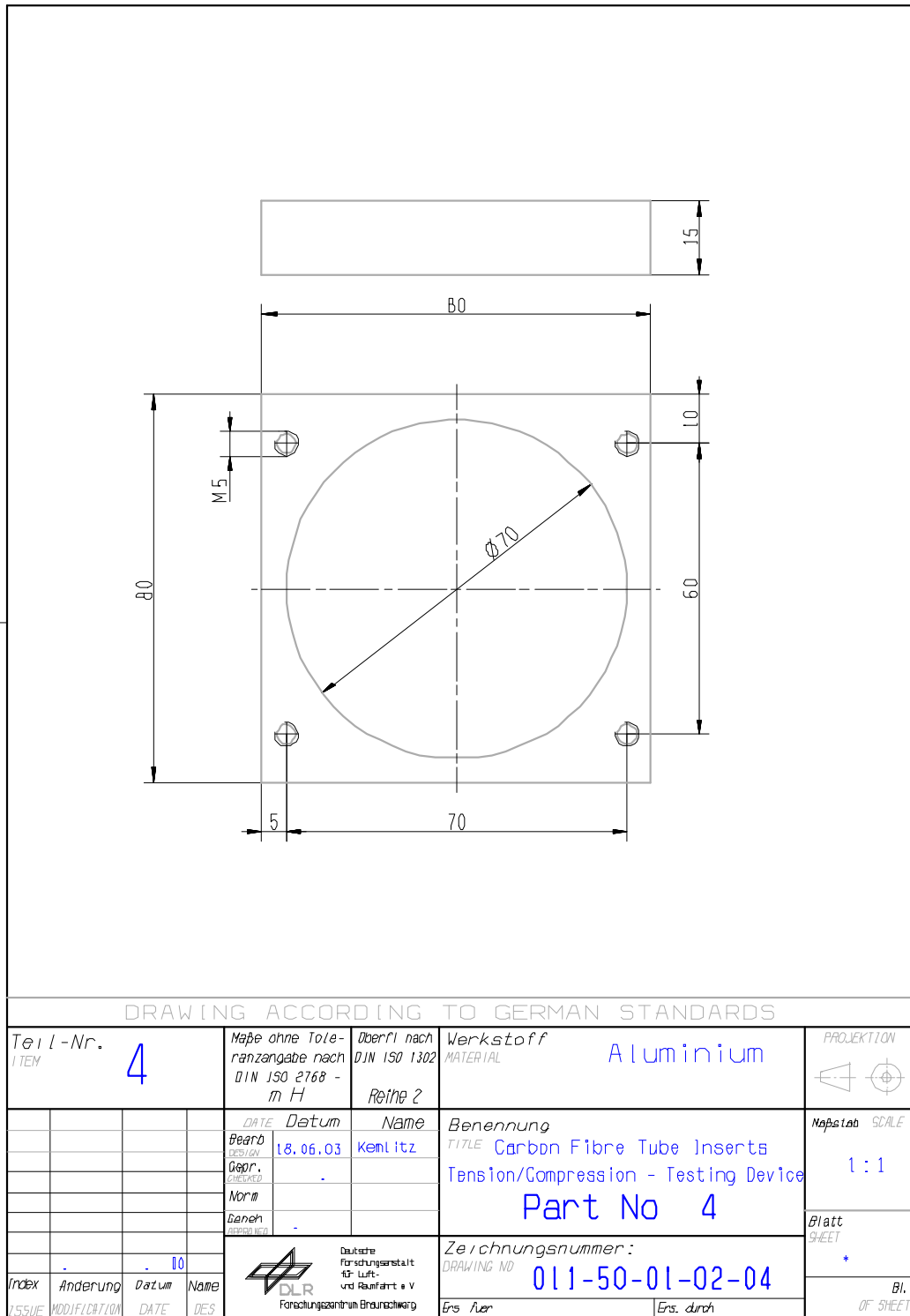

Figure H-5: Test fixture: Tension-compression load – part 4

H.2.1.6 Part 5

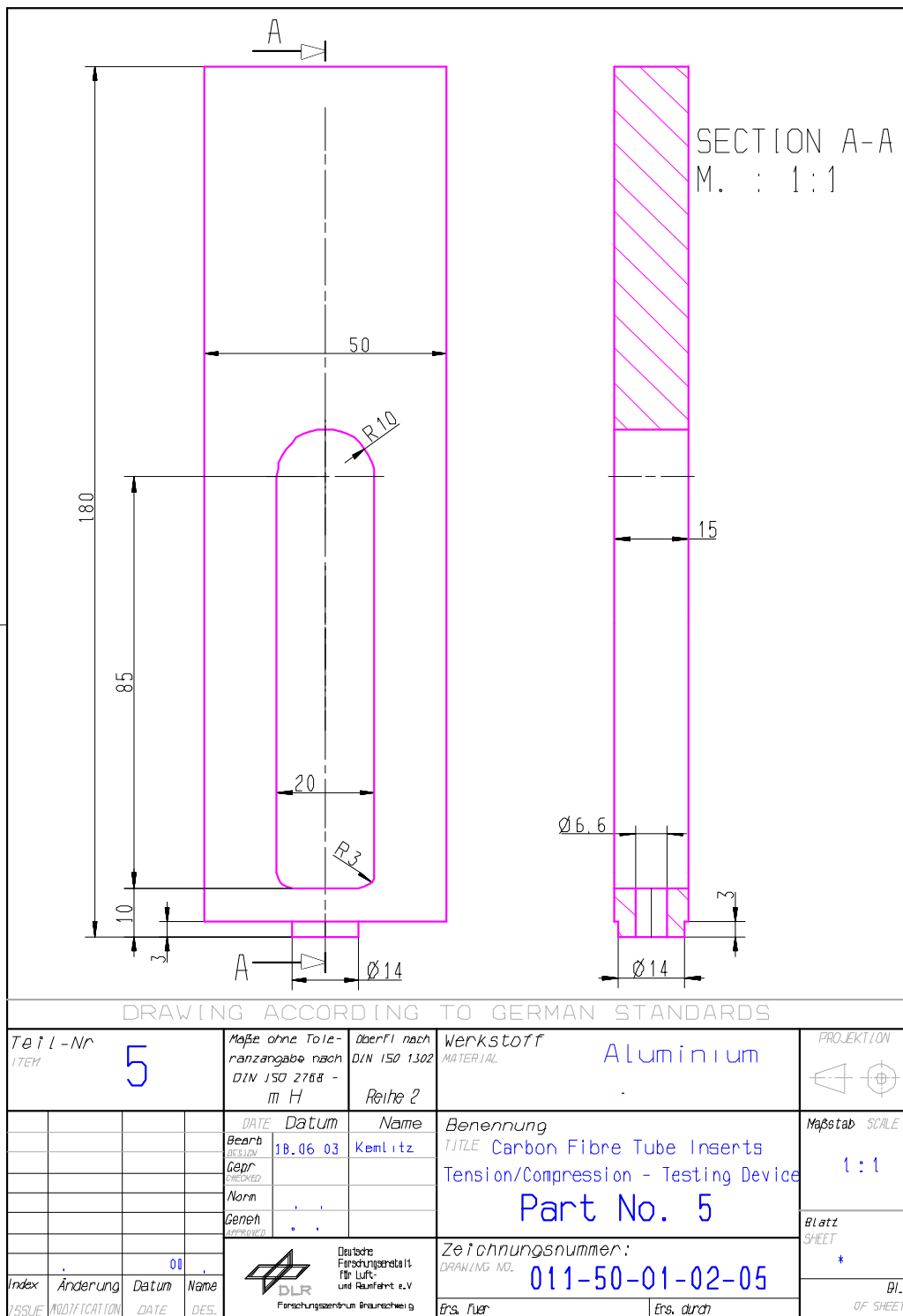

Figure H-6: Test fixture: Tension-compression load – part 5

H.2.1.7 Part 6

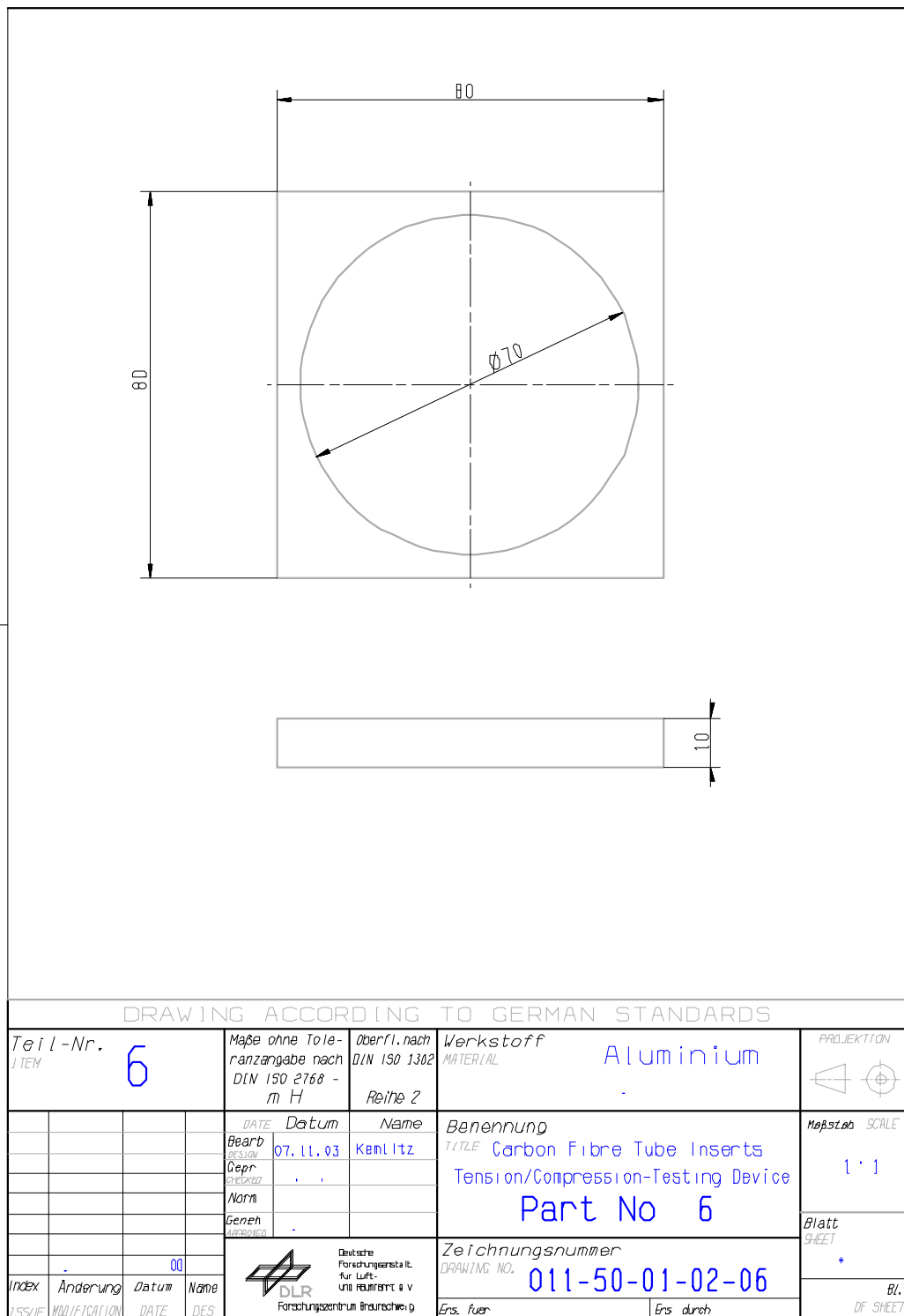

Figure H-7: Test fixture: Tension-compression load – part 6

H.2.1.8 Part 7

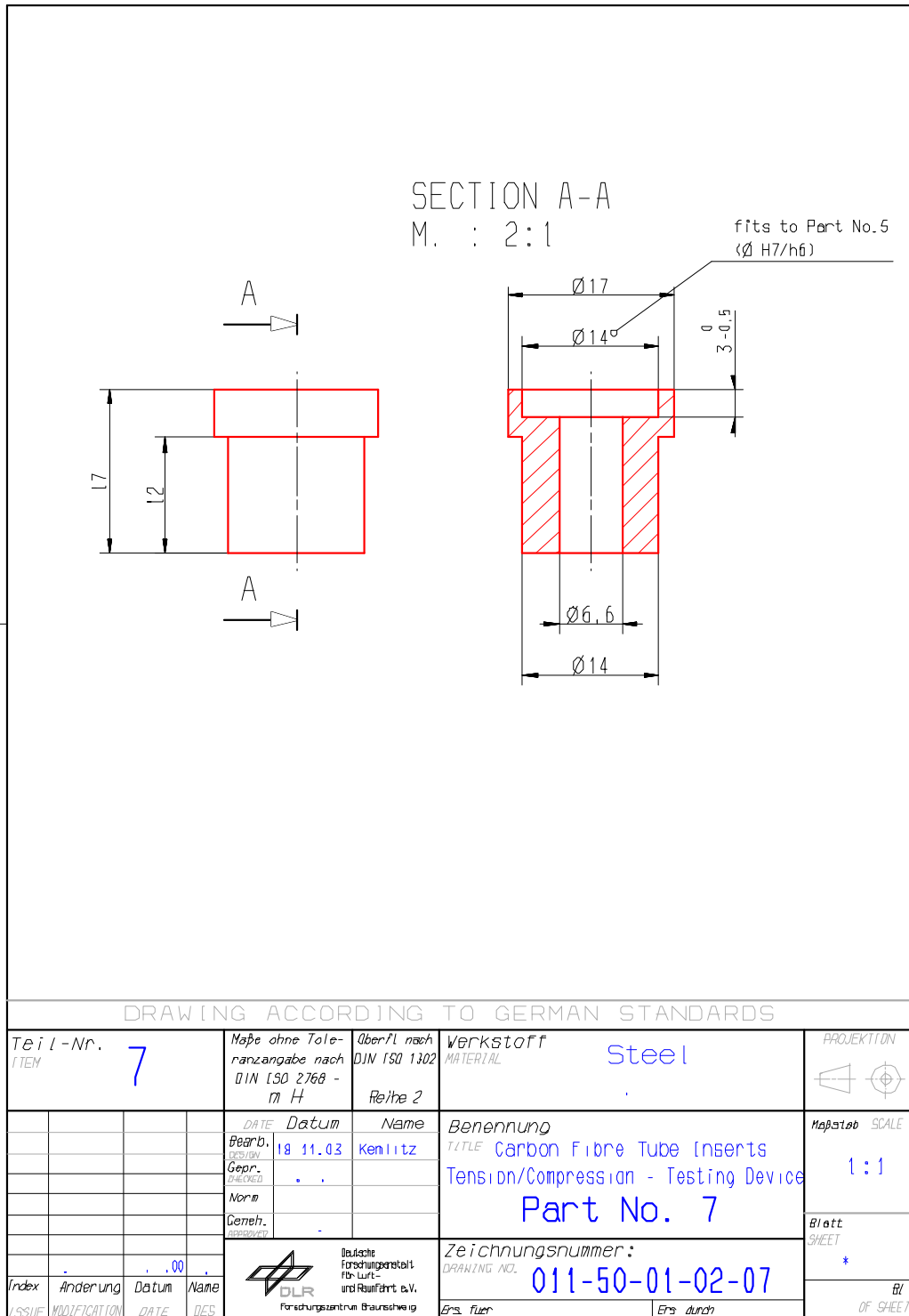

Figure H-8: Test fixture: Tension-compression load – part 7

H.3 Test fixture: In-plane shear load

The in-plane shear test fixture is described in 27.3, [See also: Figure 27-3].

The set of engineering drawings for the test fixture are shown divided into several parts:

- Master drawing, in Figure H-9
- Part 1, in Figure H-10
- Part 2, in Figure H-11
- Part 3, in Figure H-12
- Part 4, in Figure H-13
- Part 5, in Figure H-14
- Part 6, in Figure H-15
- Part 7, in Figure H-16
- Part 8, in Figure H-17

NOTE All engineering drawings reproduced courtesy of DLR

H.3.1 Master drawing

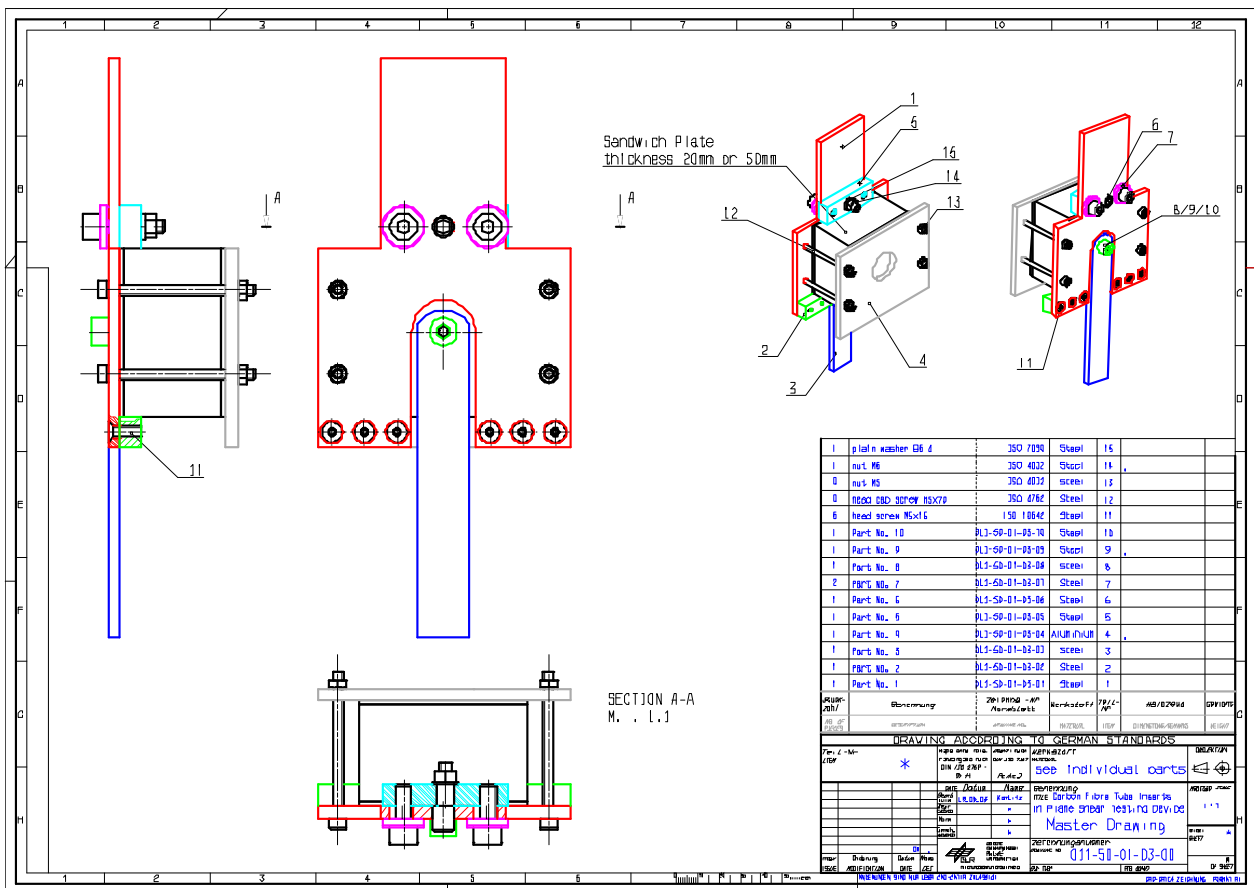

Figure H-9: Test fixture: In-plane shear load – master drawing

H.3.1.2 Part 1

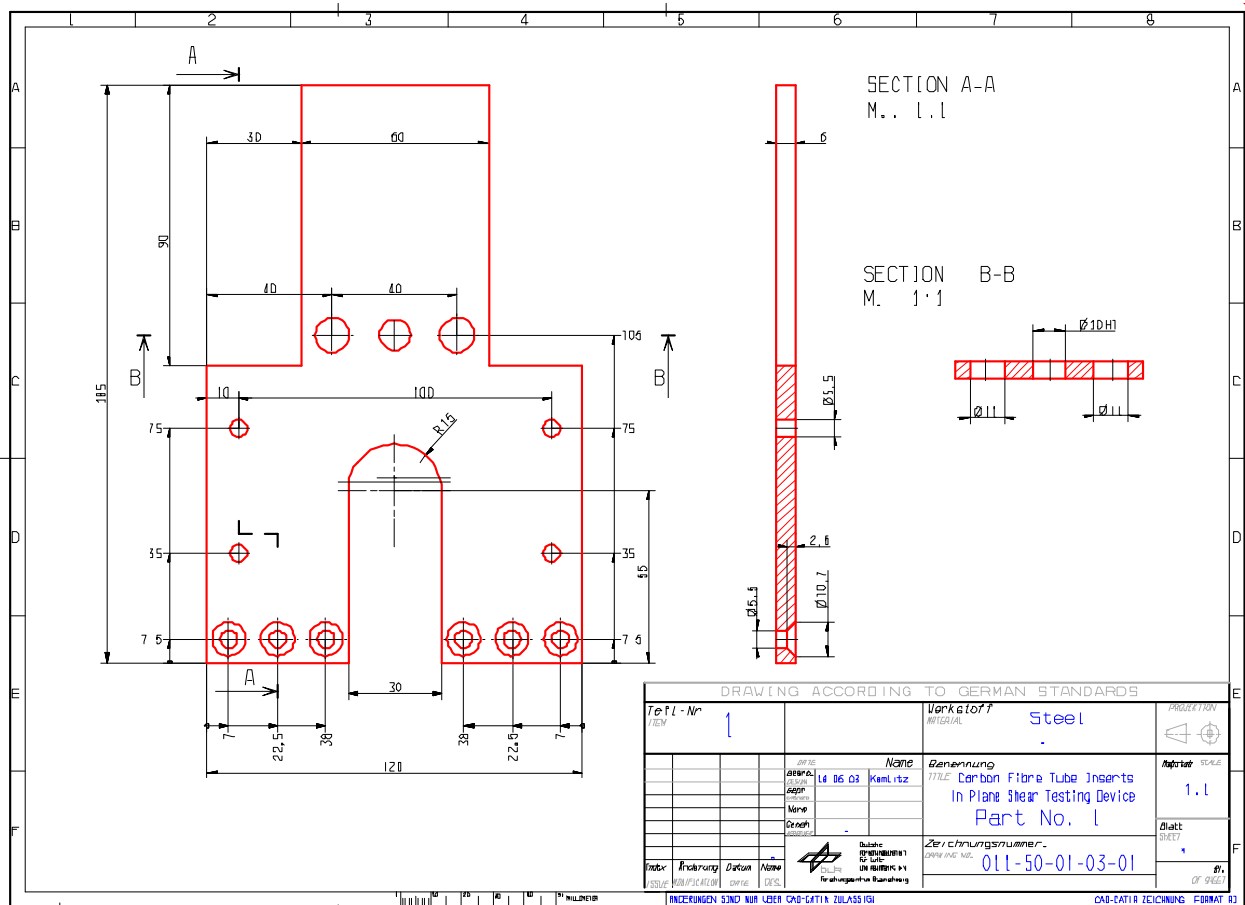

Figure H-10: Test fixture: In-plane shear load – part 1

H.3.1.3 Part 2

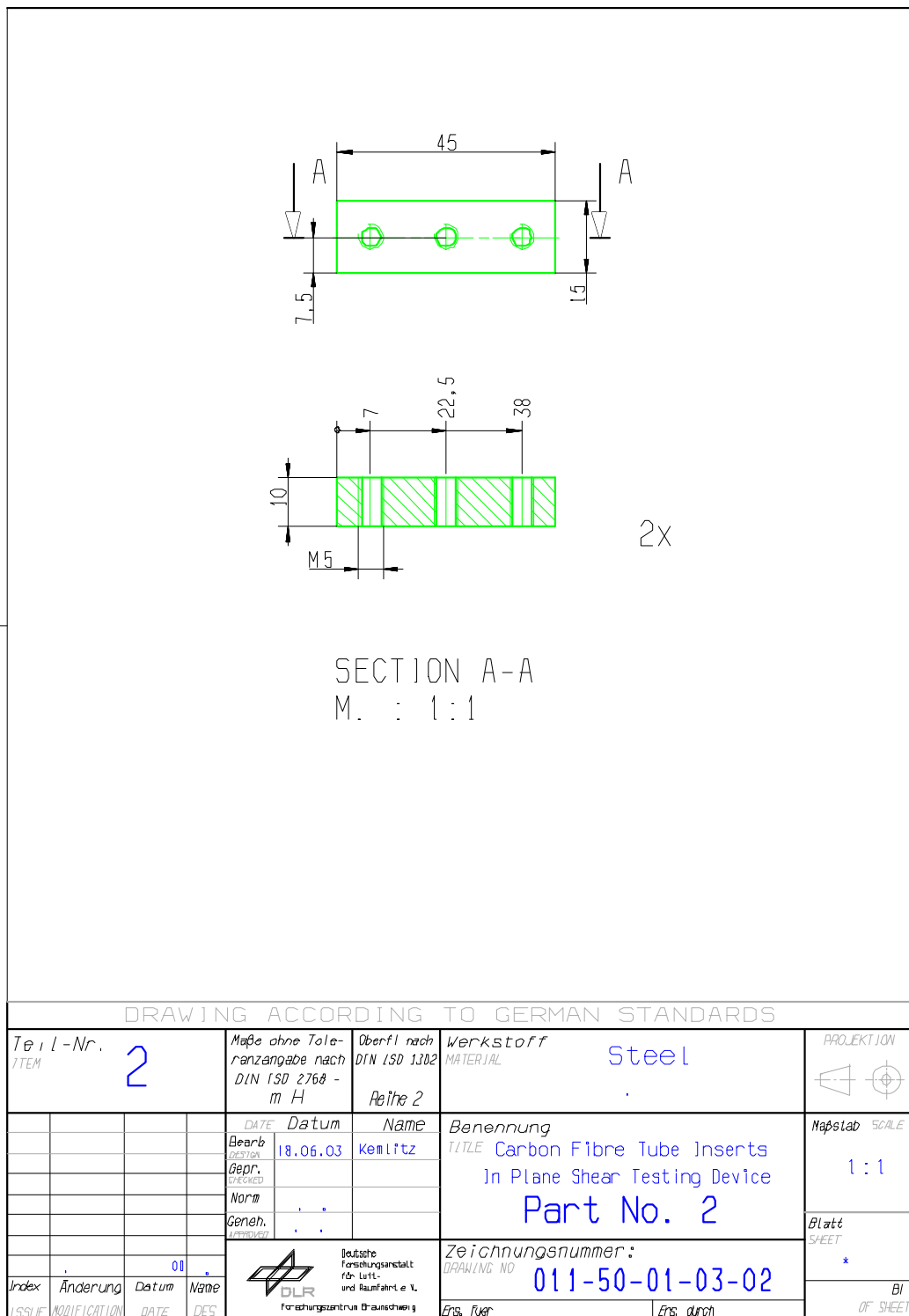
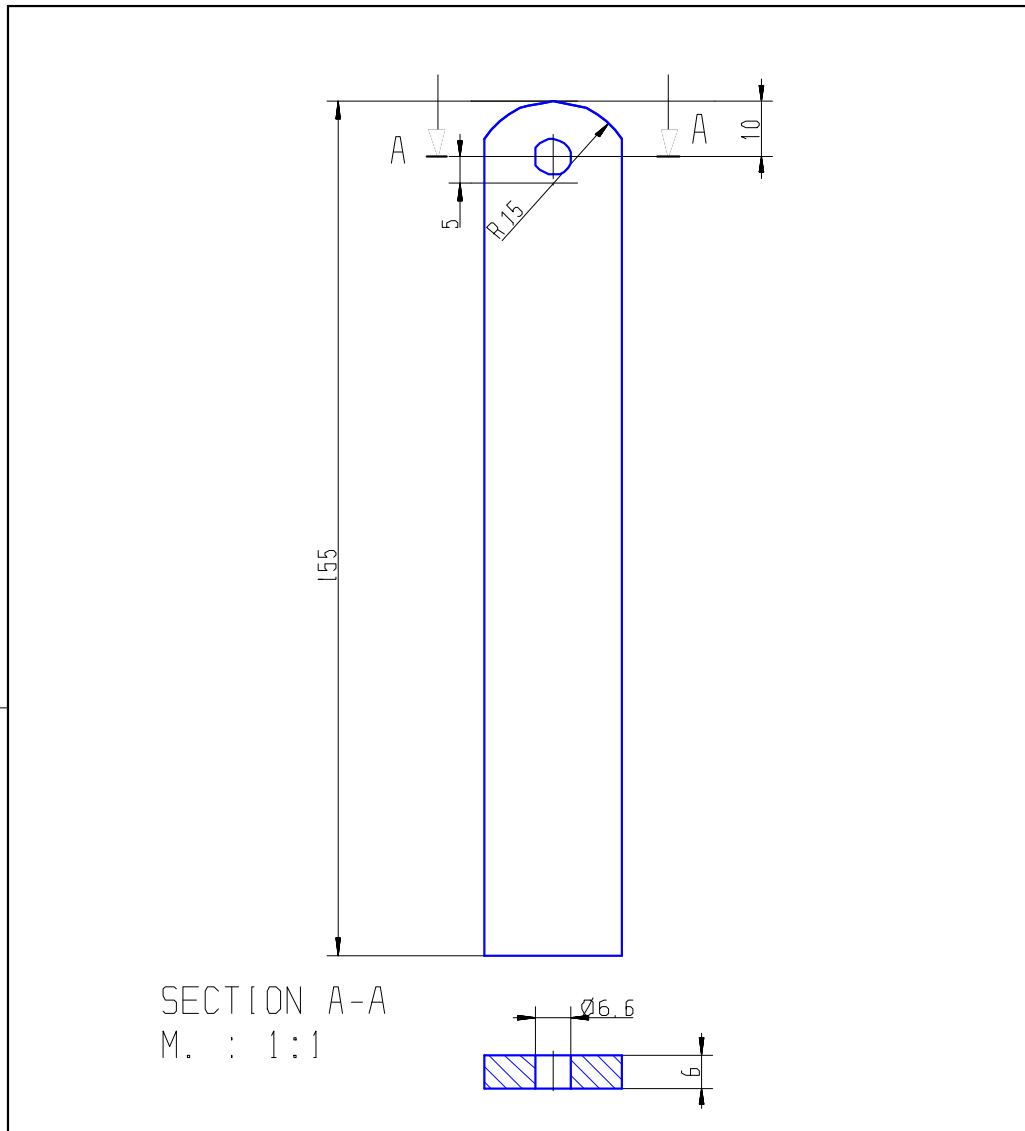
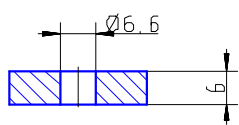

Figure H-11: Test fixture: In-plane shear load – part 2

H.3.1.4 Part 3



SECTION A-A
 M. : 1:1



DRAWING ACCORDING TO GERMAN STANDARDS

Teil-Nr. ITEM		Maße ohne Toleranzangabe nach DIN 150 2768 - m H		Oberfl.nach DIN 150 1302		Werkstoff MATERIAL		PROJEKTION	
3				Reihe 2		Steel			
		DATE Datum		Name		Benennung TITLE		Maßstab SCALE	
		18 06 03		Kernlitz		Carbon Fibre Tube Inserts In Plane Shear Testing Device Part No. 3		1 : 1	
		Norm						Blatt SHEET	
								*	
Index Änderung		Datum		Name		Zeichnungsnummer DRAWING NO.		Bl. OF SHEET	
ISSUE MODIFICATION		DATE		DES		011-50-01-03-03			
				Deutsche Forschungsanstalt für Luft- und Raumfahrt e.V. Forschungszentrum Braunschweig		Ers. über		Ers. durch	

Figure H-12: Test fixture: In-plane shear load – part 3

H.3.1.5 Part 4

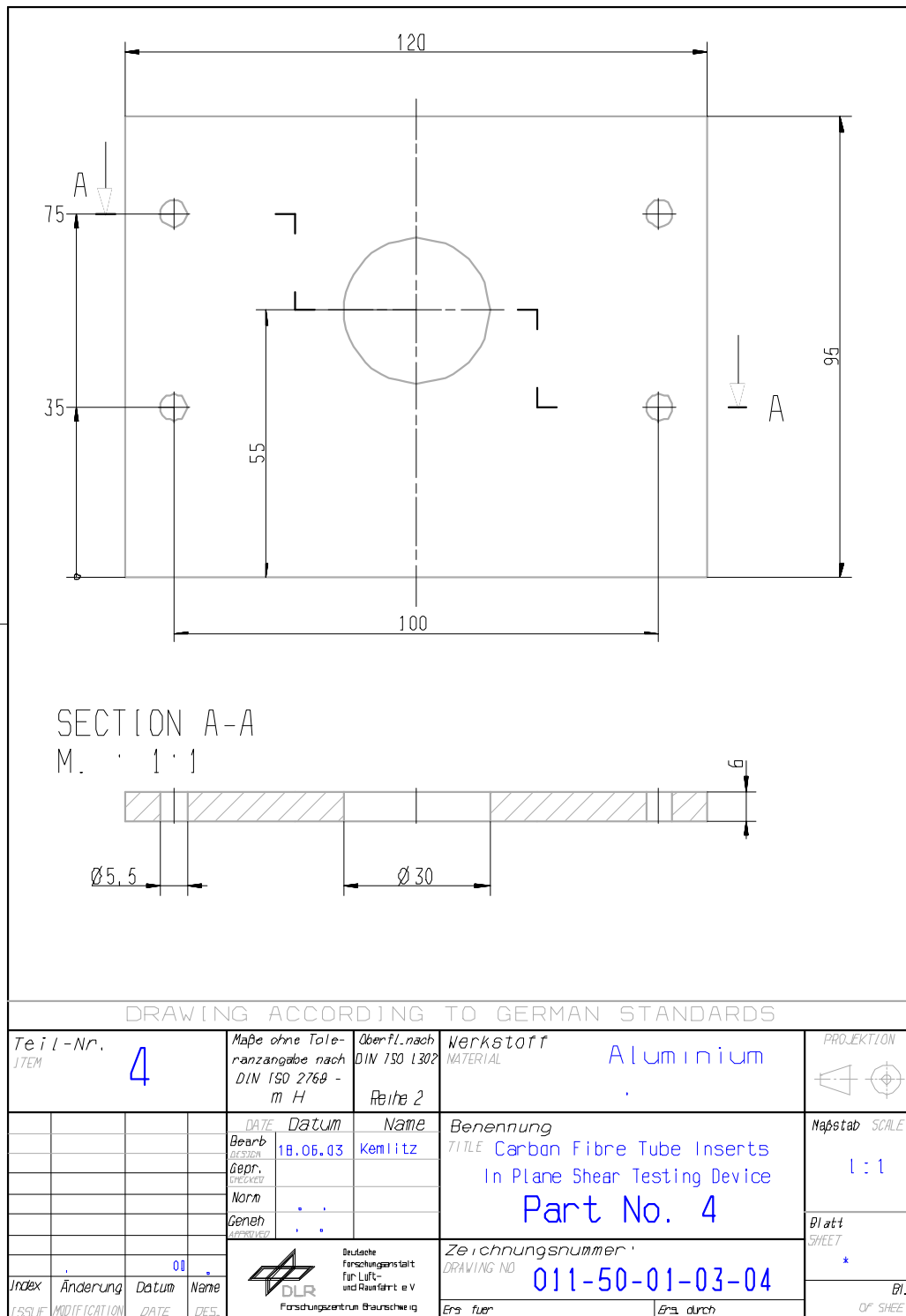

Figure H-13: Test fixture: In-plane shear load – part 4

H.3.1.6 Part 5

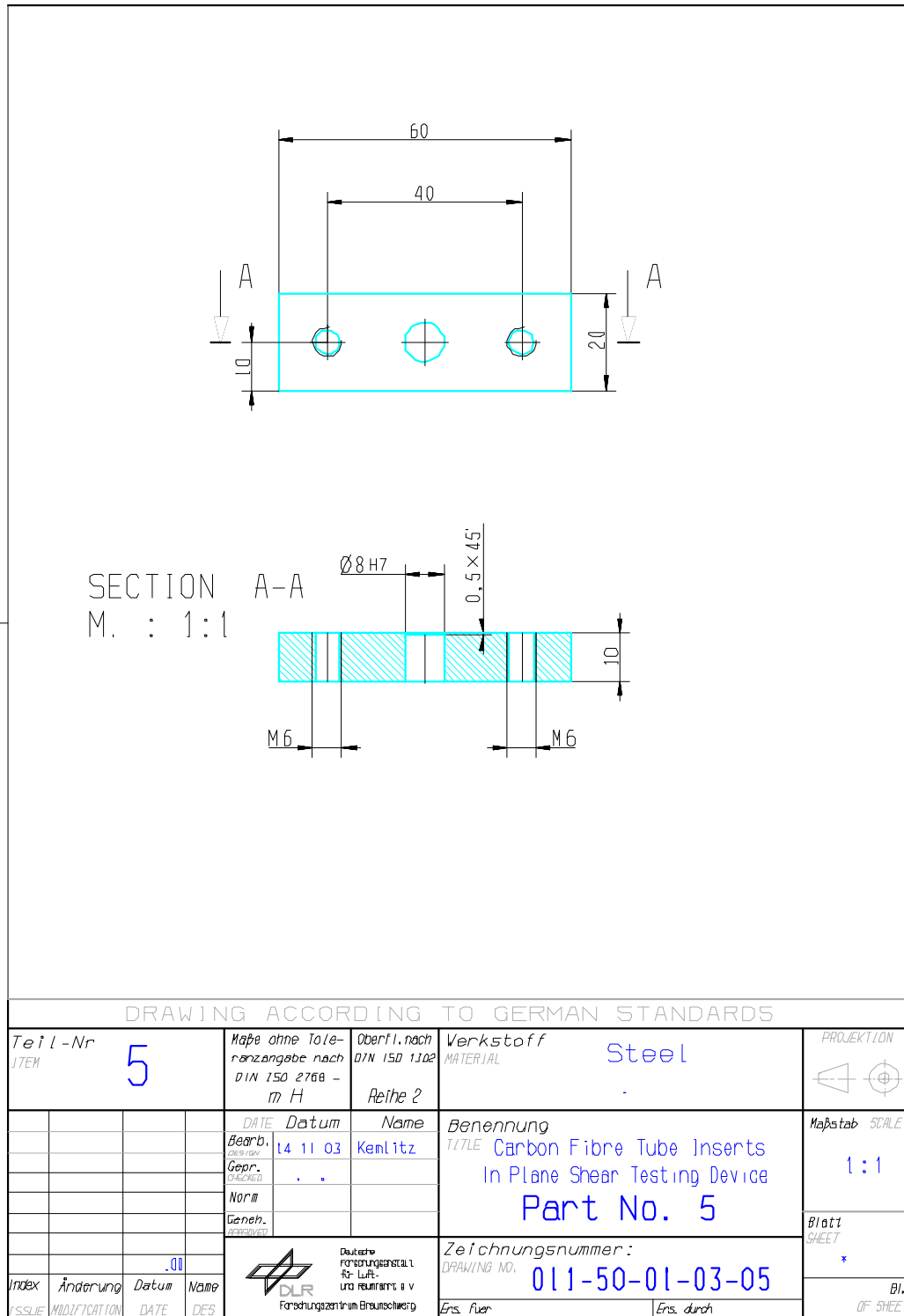

Figure H-14: Test fixture: In-plane shear load – part 5

H.3.1.8 Part 7

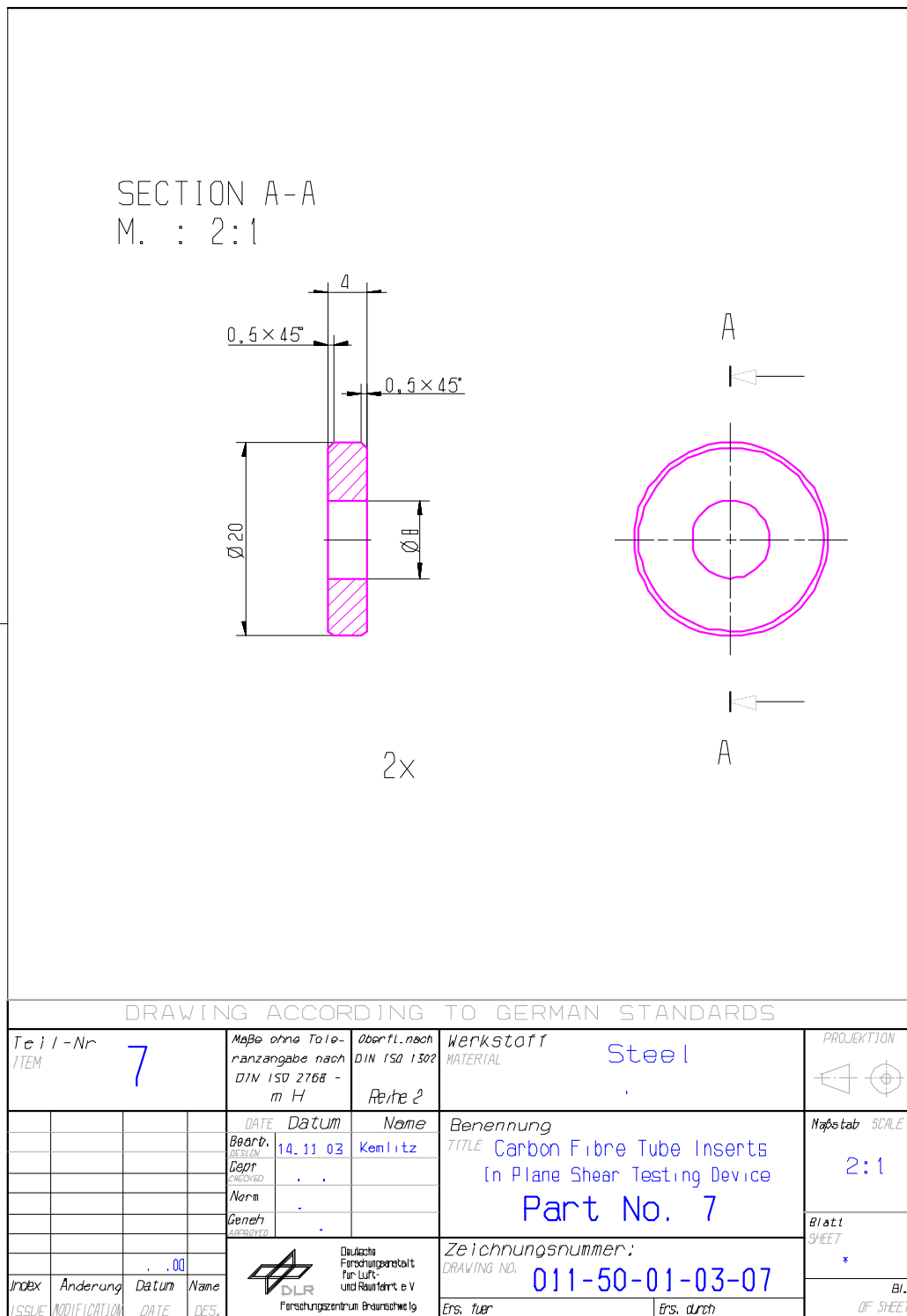

Figure H-16: Test fixture: In-plane shear load – part 7

H.3.1.9 Part 8

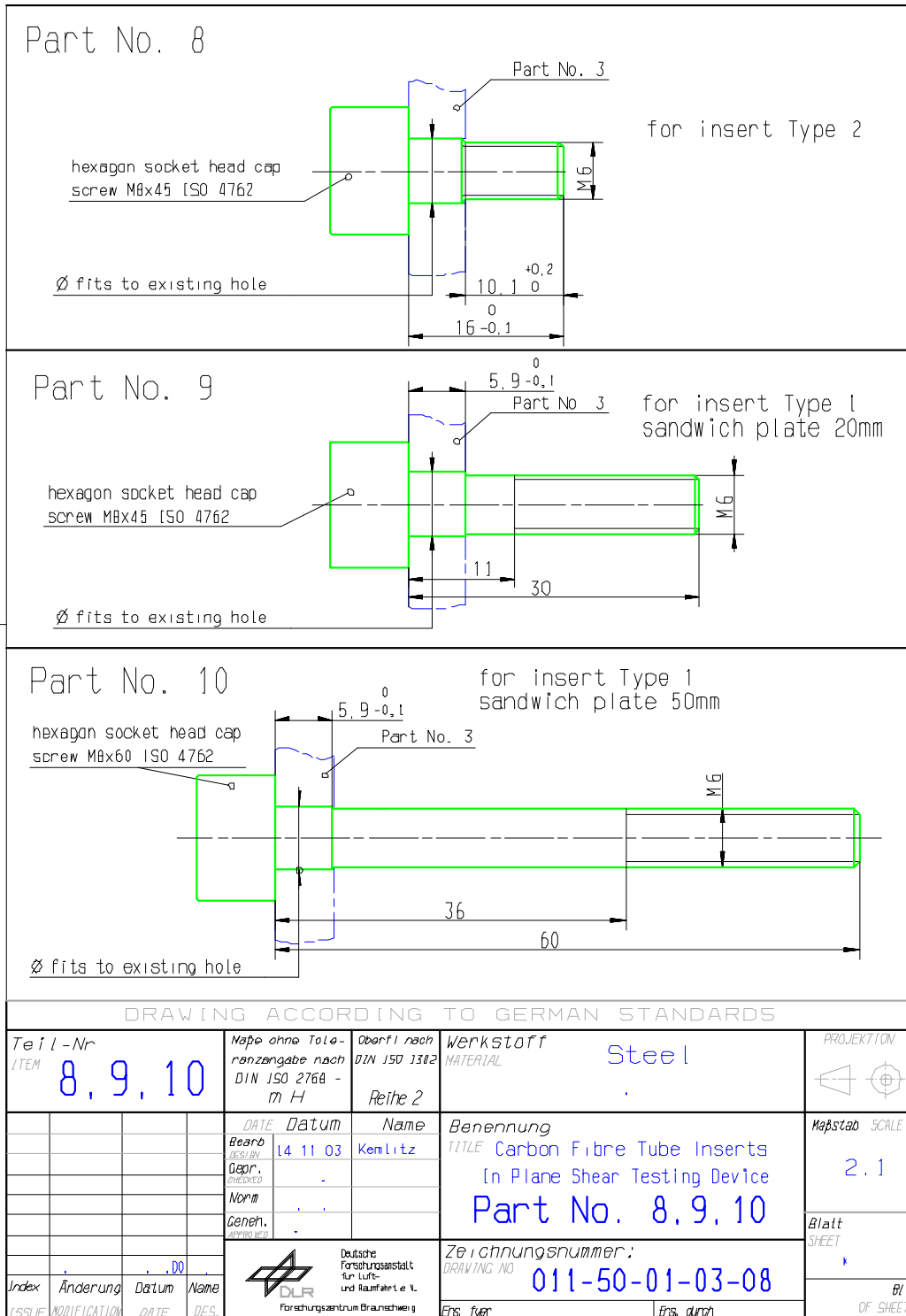

Figure H-17: Test fixture: In-plane shear load – part 8

H.4 Test fixture: Bending

The bending test fixture is described in 27.3, [See also: Figure 27-4].

The set of engineering drawings for the test fixture are shown divided into several parts:

- Master drawing, in Figure H-18
- Part 1, in Figure H-19
- Part 2, in Figure H-20
- Part 3, in Figure H-21
- Part 4, in Figure H-22
- Part 5, in Figure H-23
- Part 6, in Figure H-24
- Part 7, in Figure H-25
- Part 8, in Figure H-26
- Part 9, in Figure H-27
- Part 10, in Figure H-28
- Part 11. 12 and 13, in Figure H-29
- Part 14, in Figure H-30

H.4.1 Master drawing

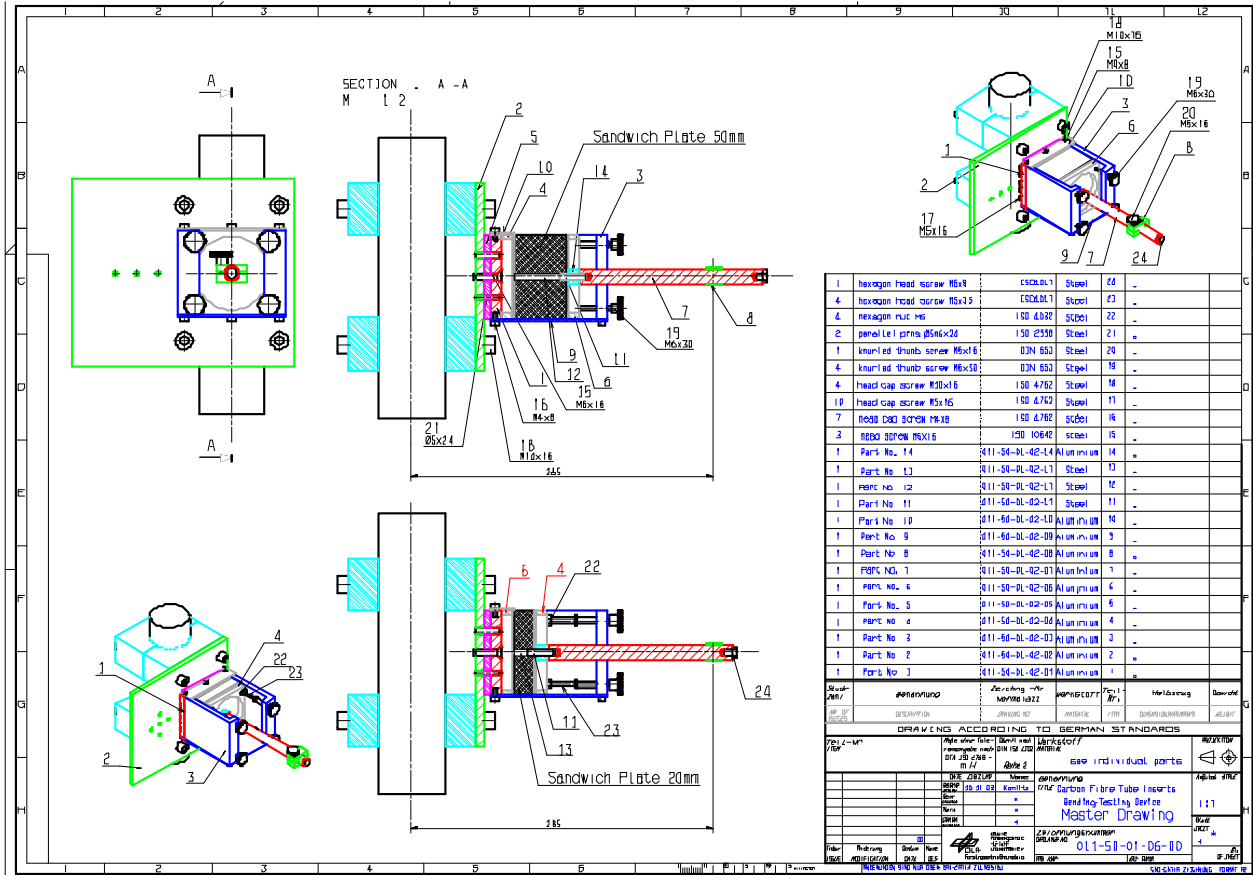

Figure H-18: Test fixture: Bending – master drawing

H.4.1.2 Part 1

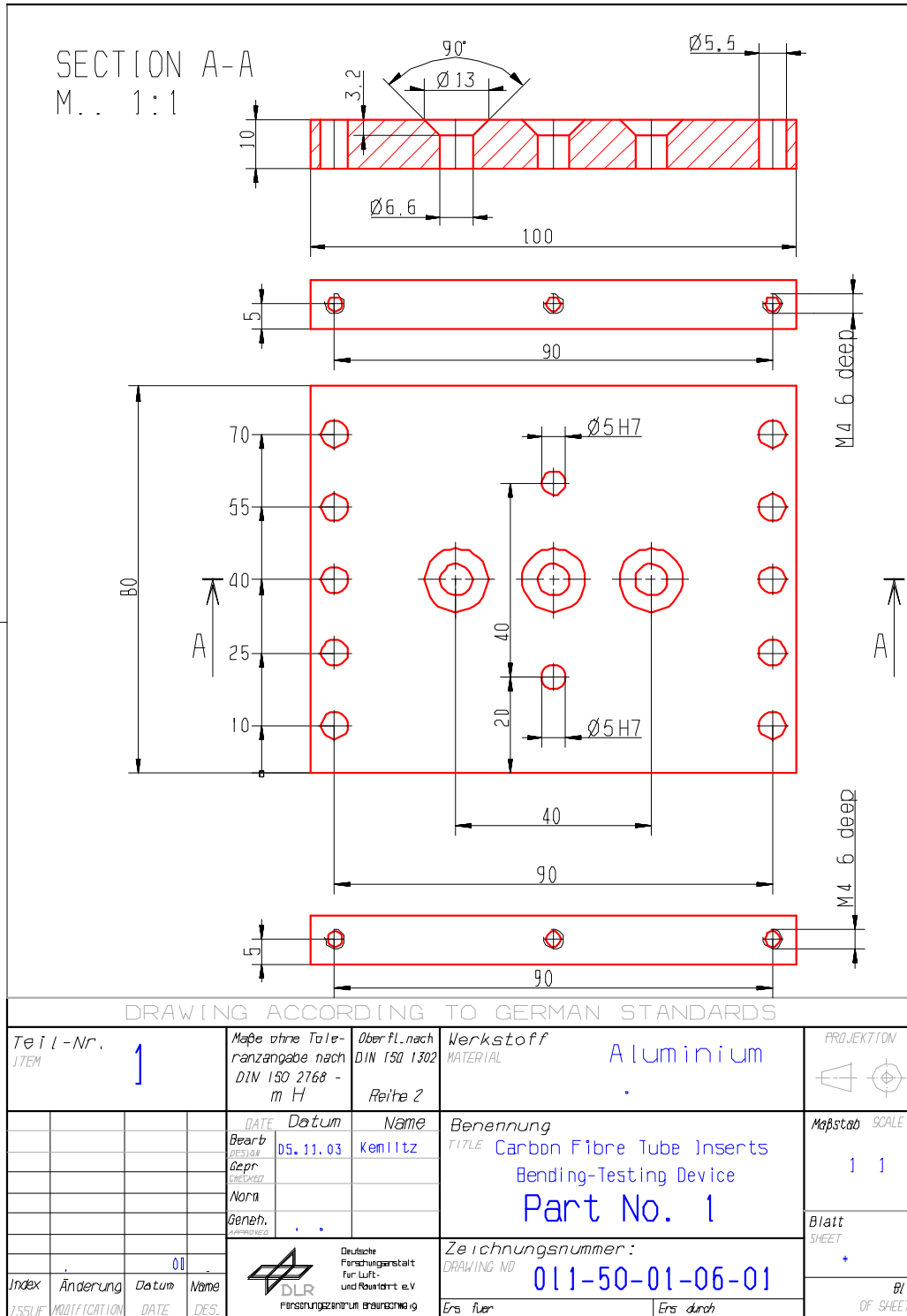
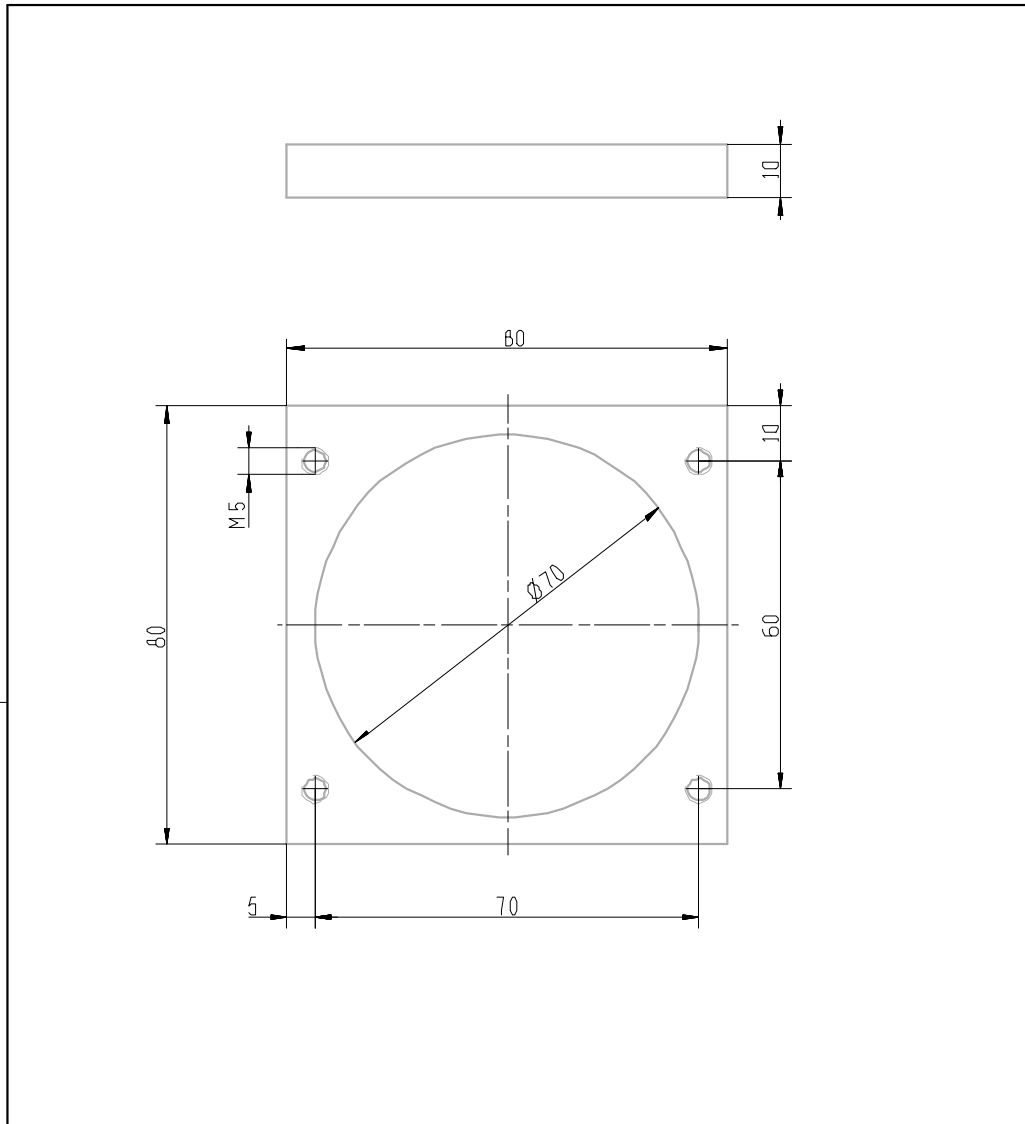

Figure H-19: Test fixture: Bending – part 1

H.4.1.5 Part 4



DRAWING ACCORDING TO GERMAN STANDARDS

Teil-Nr. ITEM		4		Maße ohne Toleranzangabe nach DIN ISO 2768 - m H	Oberfl. nach DIN ISO 1302 Reihe 2	Werkstoff MATERIAL	Aluminium	PROJEKTION	
	DATE	Datum	Name	Benennung	Mapstab	SCALE			
	Bearb. DESIGN	10.11.03	Kemnitz	TITLE Carbon Fibre Tube Inserts Bending-Testing Device Part No 4	1	1			
	Gepr. CHECKED								
	Norm								
	Geneh. APPROVED								
		01		Zeichnungsnummer DRAWING NO.					
Index	Änderung	Datum	Name	011-50-01-06-04					
ISSUE	MODIFICATION	DATE	DES	DLR Deutsches Forschungs- und Technologielabor Für Luft- und Raumfahrt e.V. Forschungszentrum Braunschweig	Ers. für	Ers. durch			Bl. OF SHEET

Figure H-22: Test fixture: Bending – part 4

H.4.1.6 Part 5

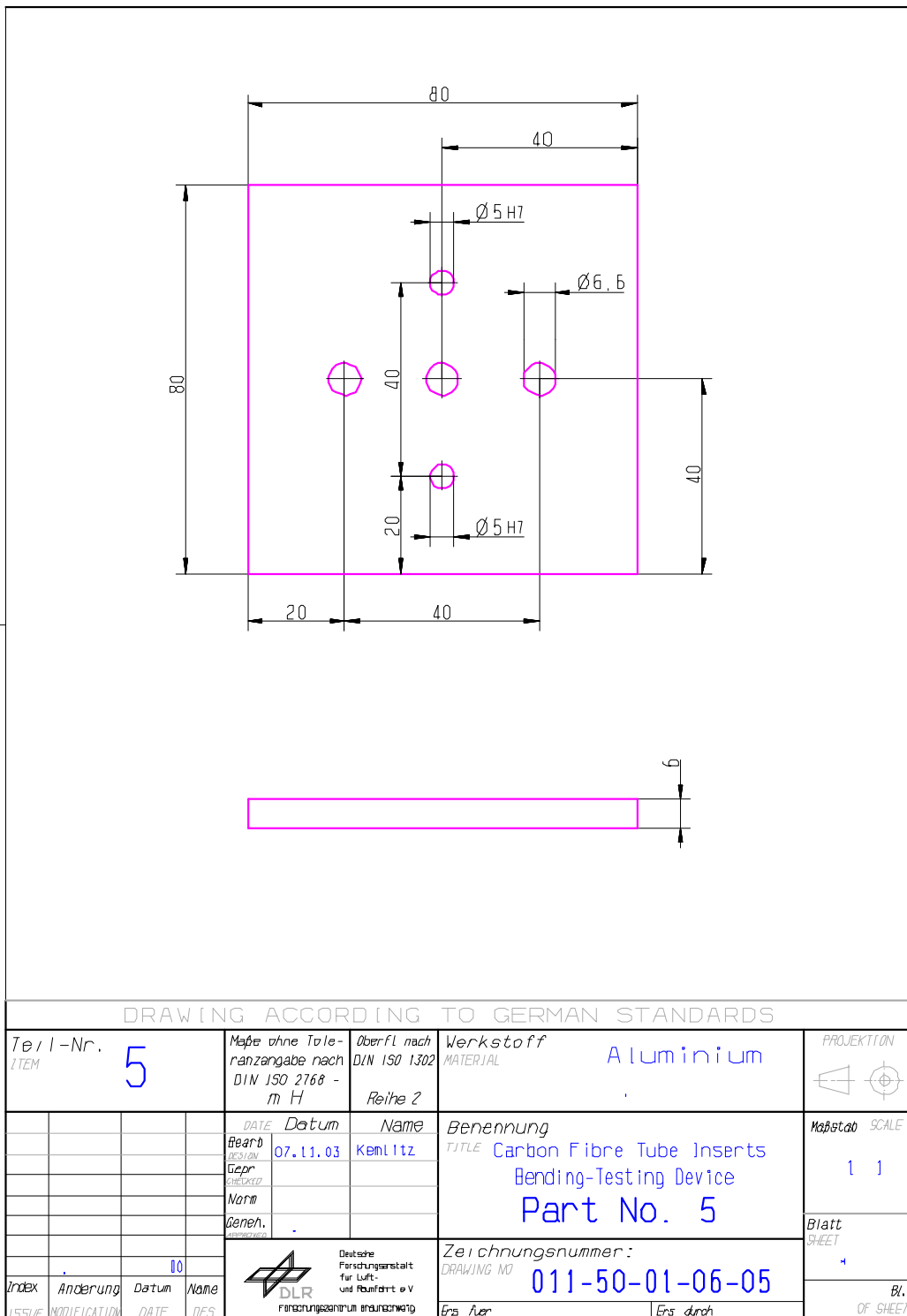

Figure H-23: Test fixture: Bending – part 5

H.4.1.7 Part 6

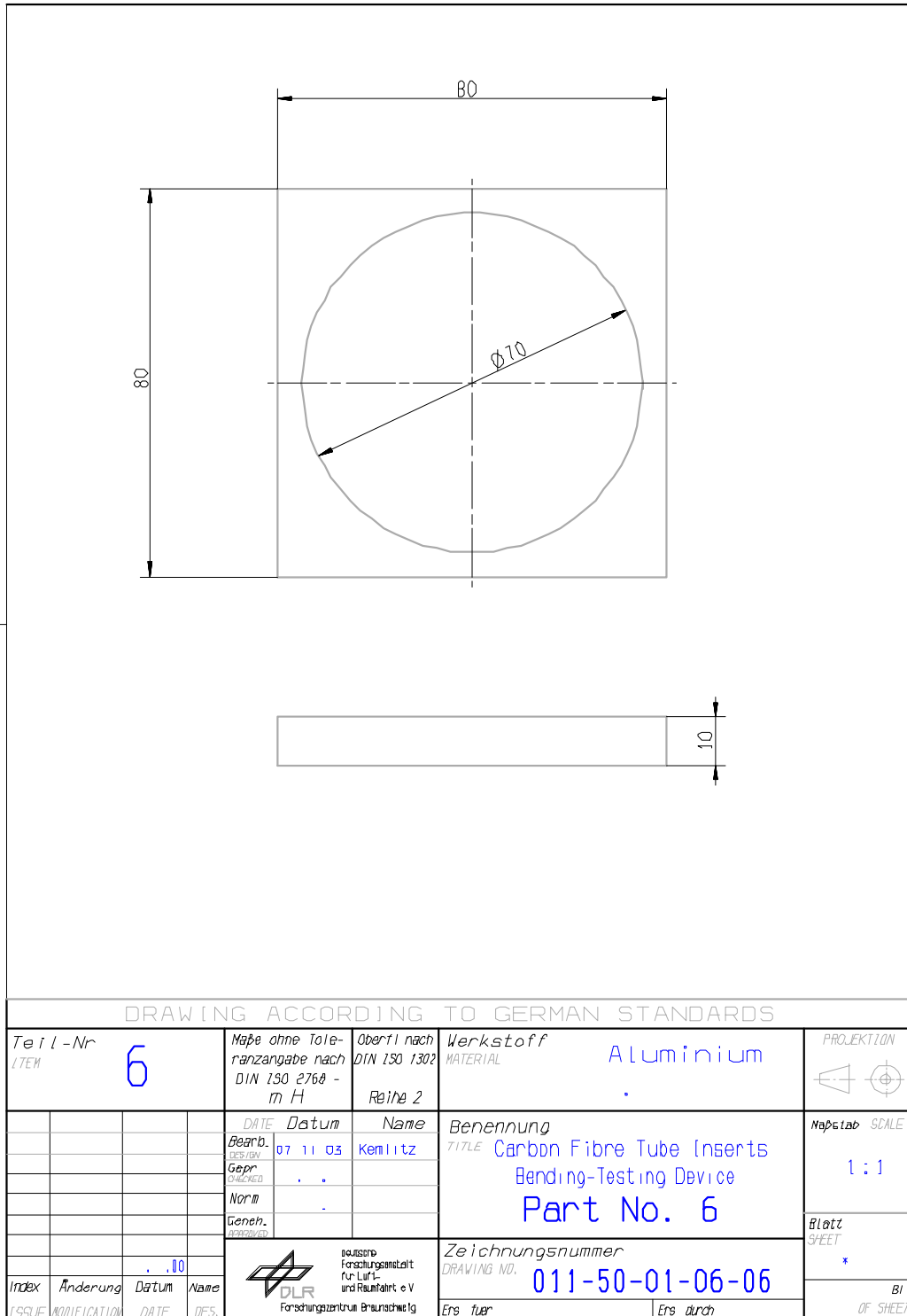

Figure H-24: Test fixture: Bending – part 6

H.4.1.8 Part 7

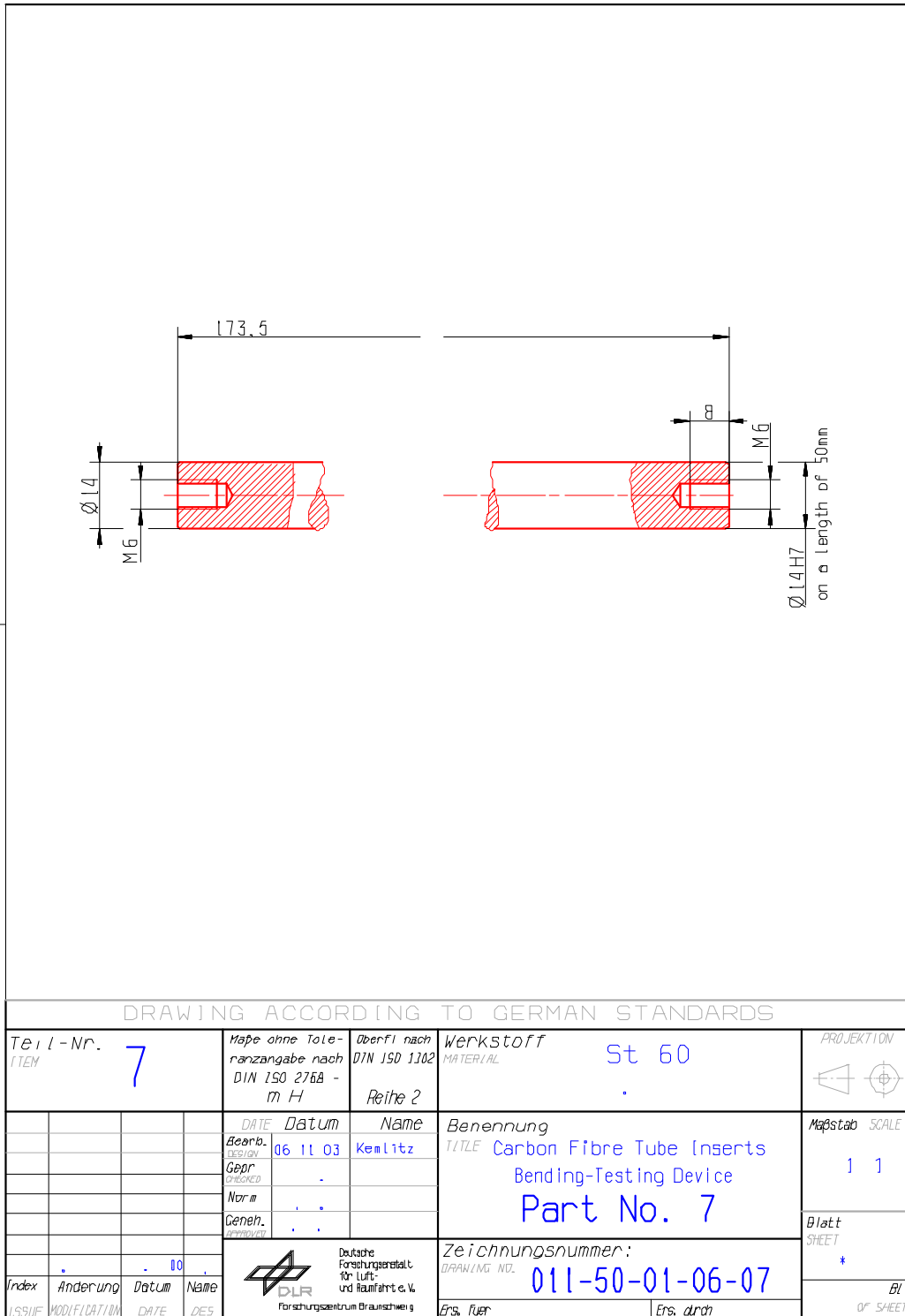

Figure H-25: Test fixture: Bending – part 7

H.4.1.10 Part 9

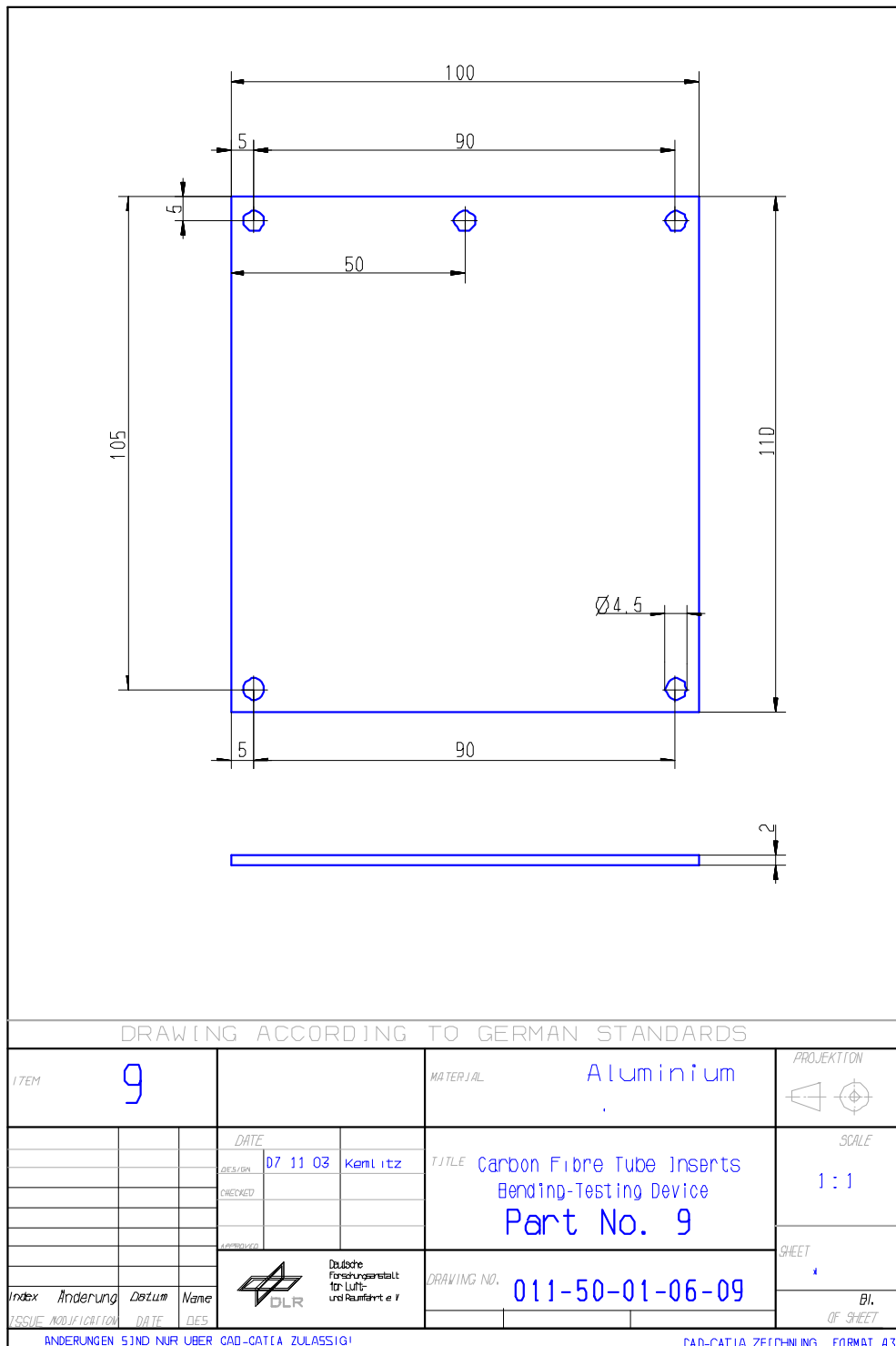

Figure H-27: Test fixture: Bending – part 9

H.4.1.11 Part 10

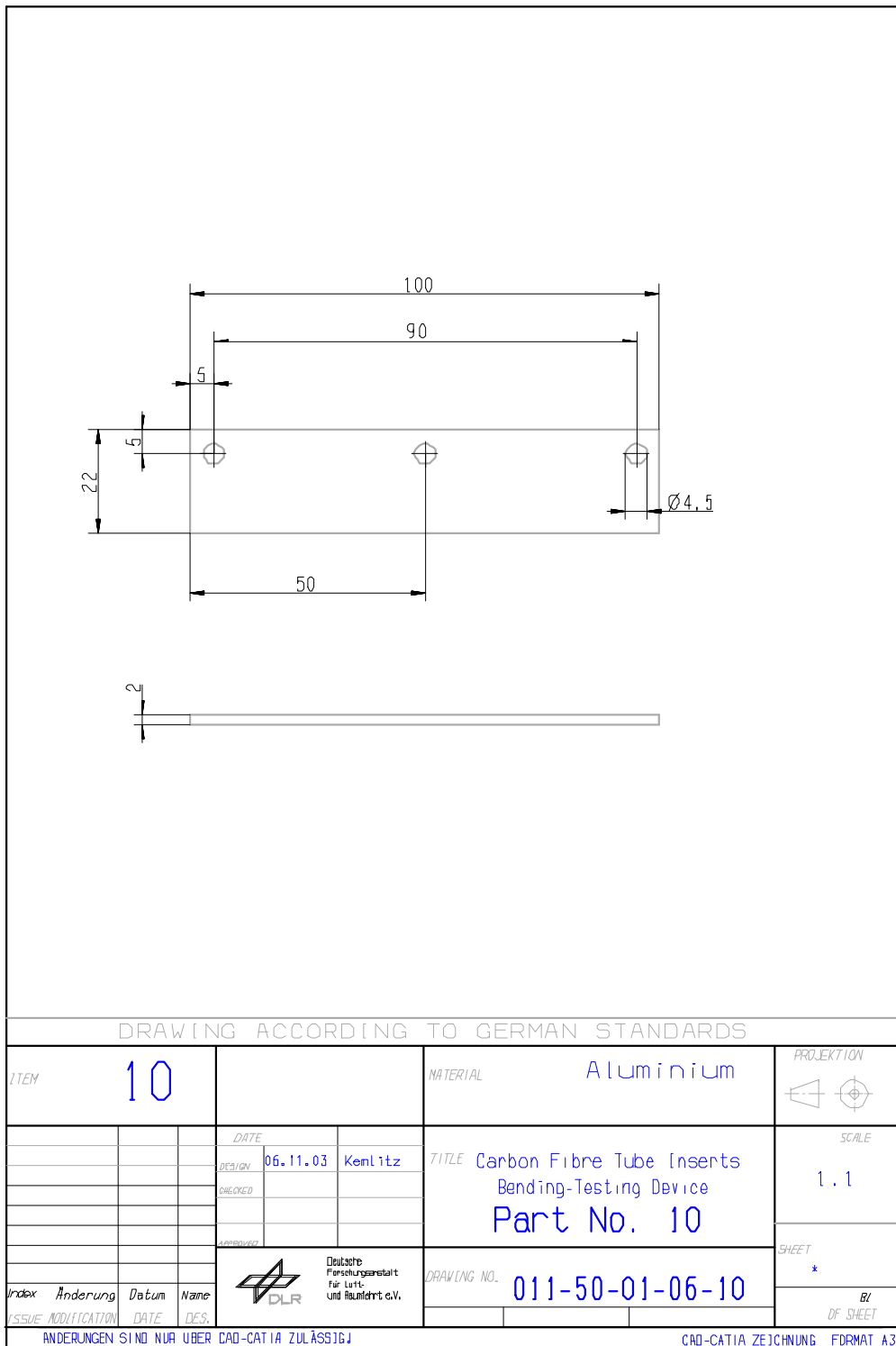

Figure H-28: Test fixture: Bending – part 10

H.4.1.12 Part 11, 12 and 13

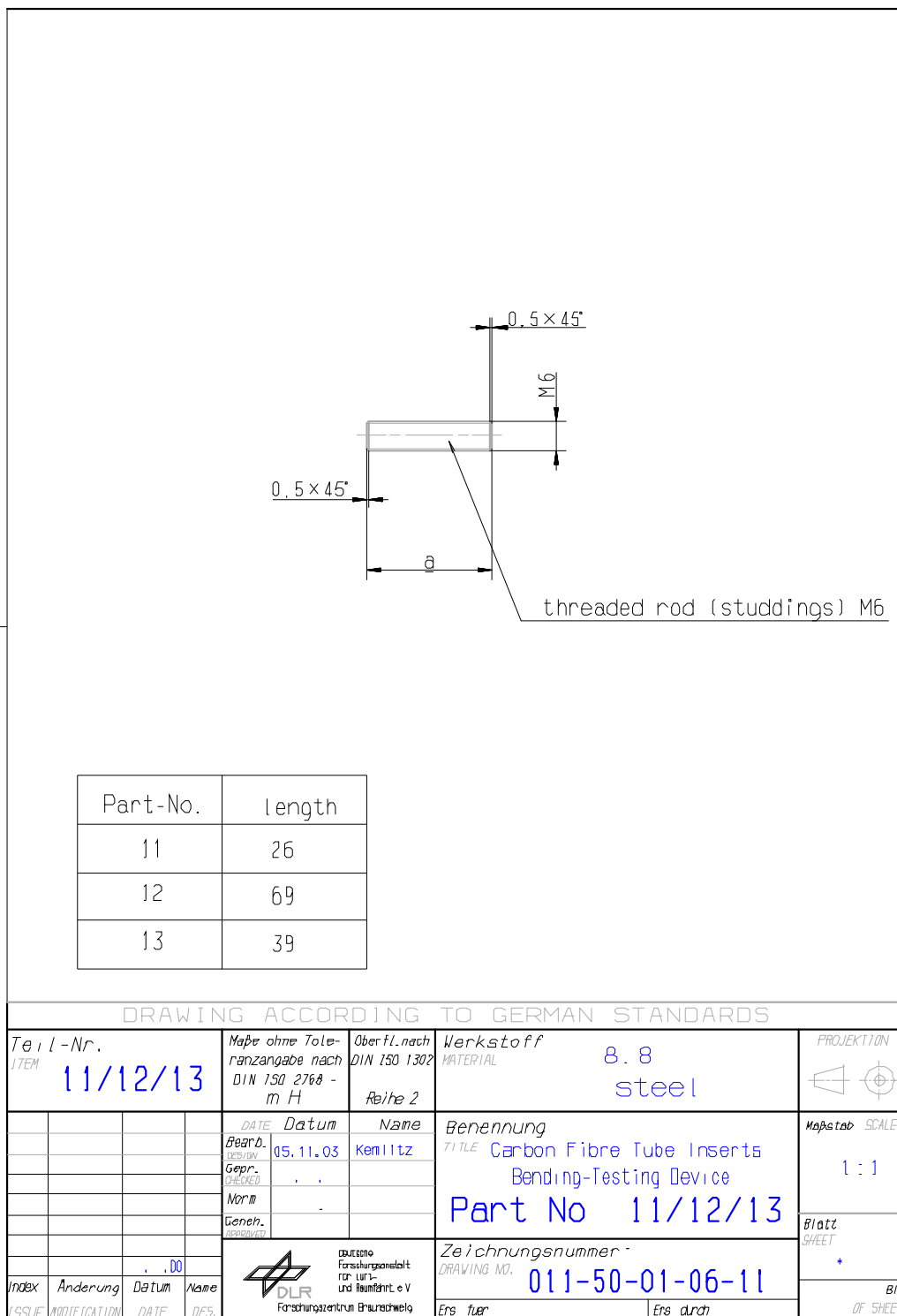
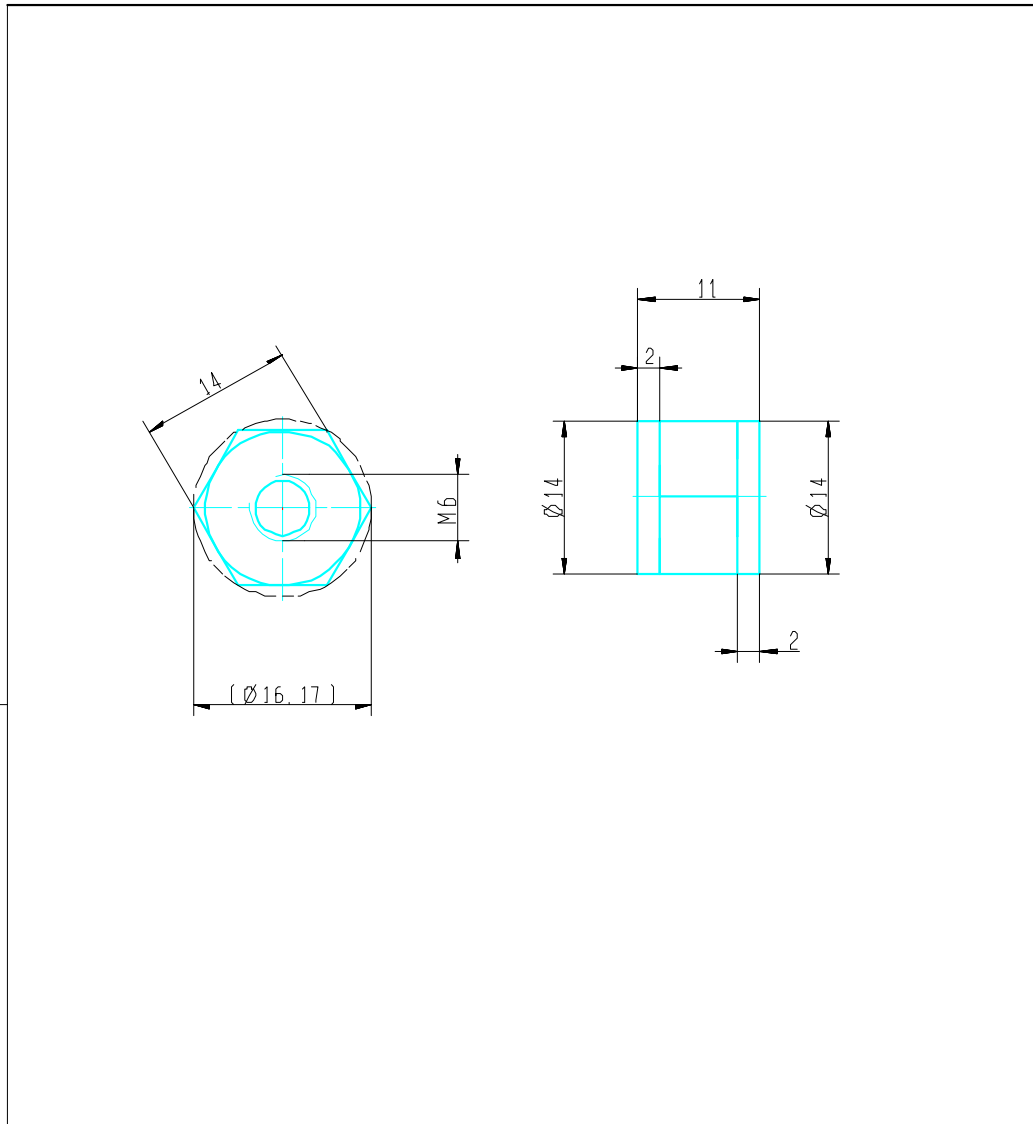

Figure H-29: Test fixture: Bending – parts 11, 12 and 13

H.4.1.13 Part 14



DRAWING ACCORDING TO GERMAN STANDARDS											
Teil-Nr ITEM		14		Maße ohne Toleranzangabe nach DIN 150 276B - m H		Oberfl. nach DIN ISO 1302 Reihe 2		Werkstoff MATERIAL		St 60	PROJEKTION
				DATE Datum		Name		Benennung TITLE		Maßstab SCALE	
				07 11 03		Kornitz		Carbon Fibre Tube Inserts Bending-Testing Device Part No. 14		2:1	
				Gepr. CHECKED		.				Blatt SHEET	
				Norm		.				*	
				Geneh. APPROVED				Zeichnungsnummer: DRAWING NO.		Bl OF SHEET	
				. . 01		DLR Deutscher Forschungsanstalt für Luft- und Raumfahrt e. V. Forschungszentrum Braunschweig		011-50-01-06-14			
Index ISSUE		Änderung MODIFICATION		Datum DATE		Name DES.		Ers. für		Ers. durch	

Figure H-30: Test fixture: Bending – part 14

H.5 Test fixture: Torsion

The torsion test fixture is described in 27.3, [See also: Figure 27-5].

The set of engineering drawings for the test fixture are shown divided into several parts:

- Master drawing, in Figure H-31
- Part 1, in Figure H-32
- Part 2, in Figure H-33
- Part 3, in Figure H-34
- Part 4, in Figure H-35
- Part 5, in Figure H-36
- Part 6, in Figure H-37
- Part 7, in Figure H-38
- Part 8, in Figure H-39
- Part 9, in Figure H-40
- Part 10, in Figure H-41
- Part 11, in Figure H-42
- Part 12, in Figure H-43
- Part 13, in Figure H-44
- Part 14, in Figure H-45
- Part 15, in Figure H-46
- Part 16, in Figure H-47
- Part 17, in Figure H-48

NOTE All engineering drawings reproduced courtesy of DLR.

H.5.1 Master drawing

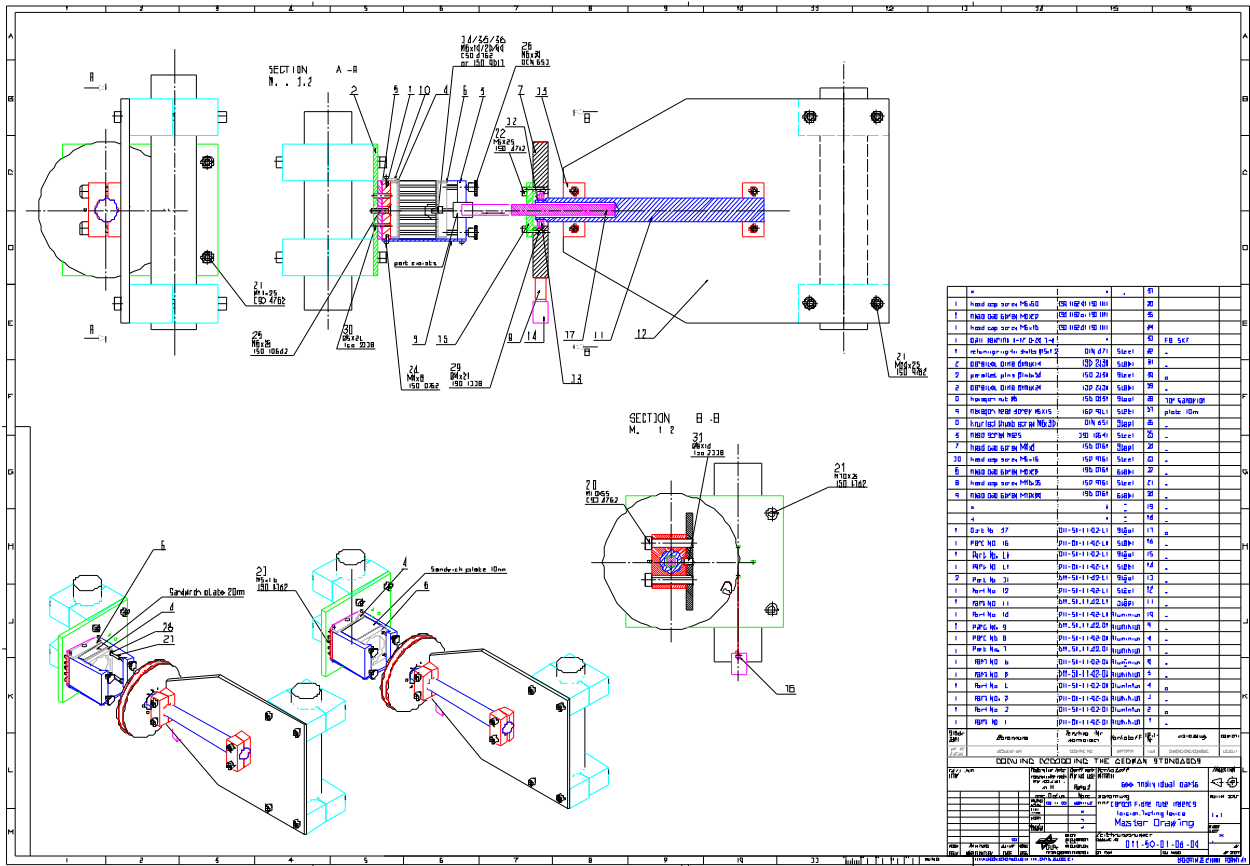

Figure H-31: Test fixture: Torsion – master drawing

H.5.1.2 Part 1

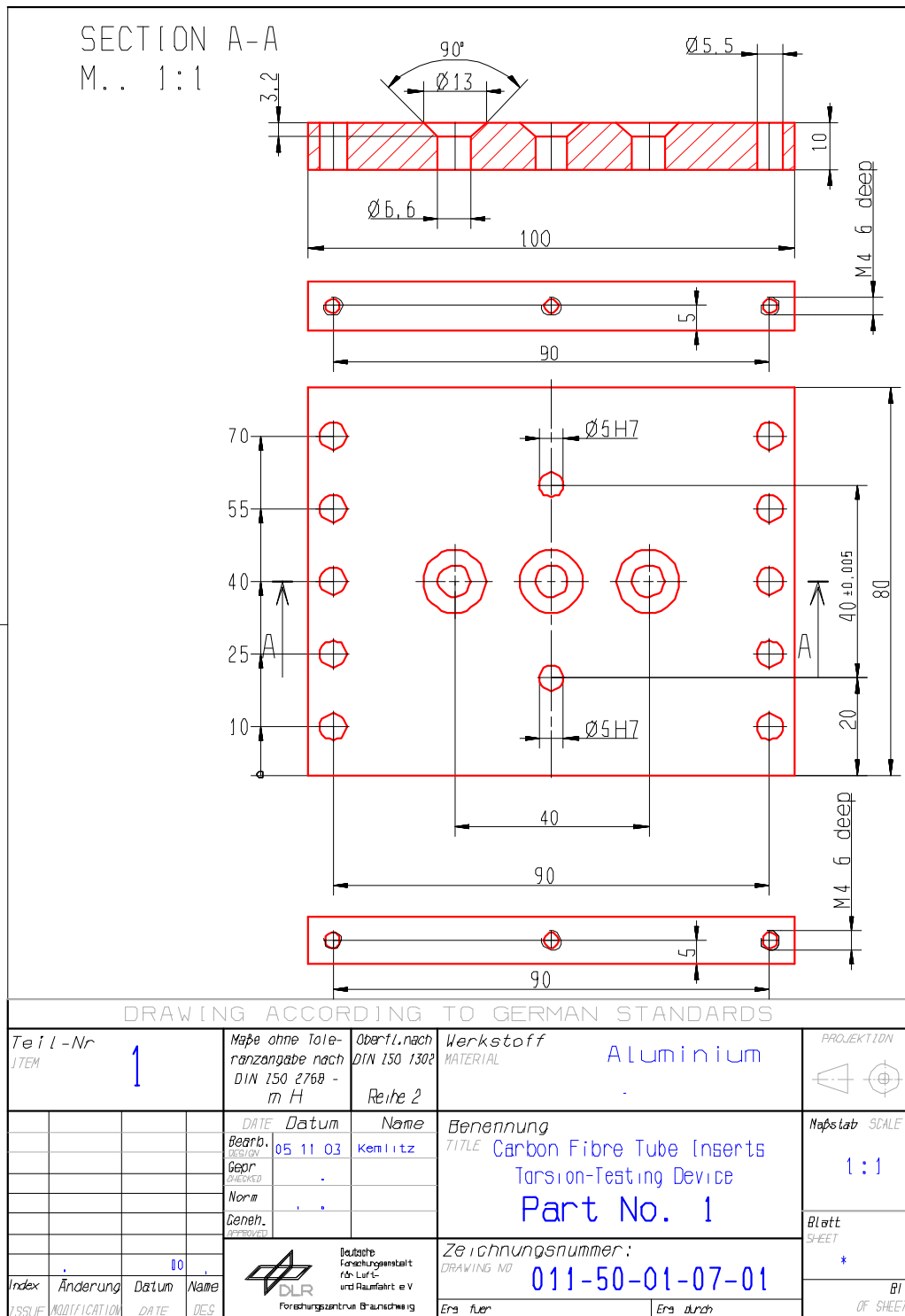

Figure H-32: Test fixture: Torsion – part 1

H.5.1.4 Part 3

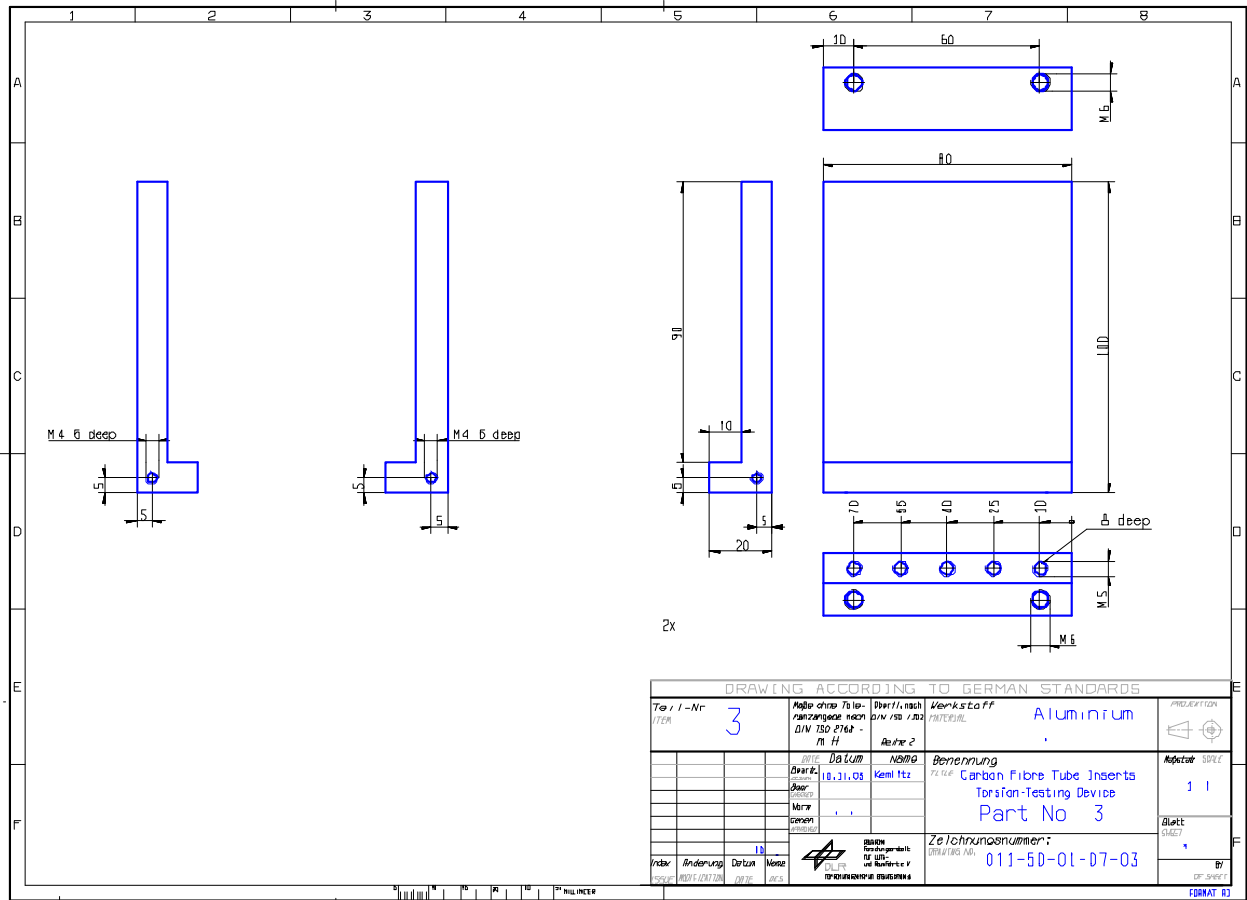

Figure H-34: Test fixture: Torsion – part 3

H.5.1.5 Part 4

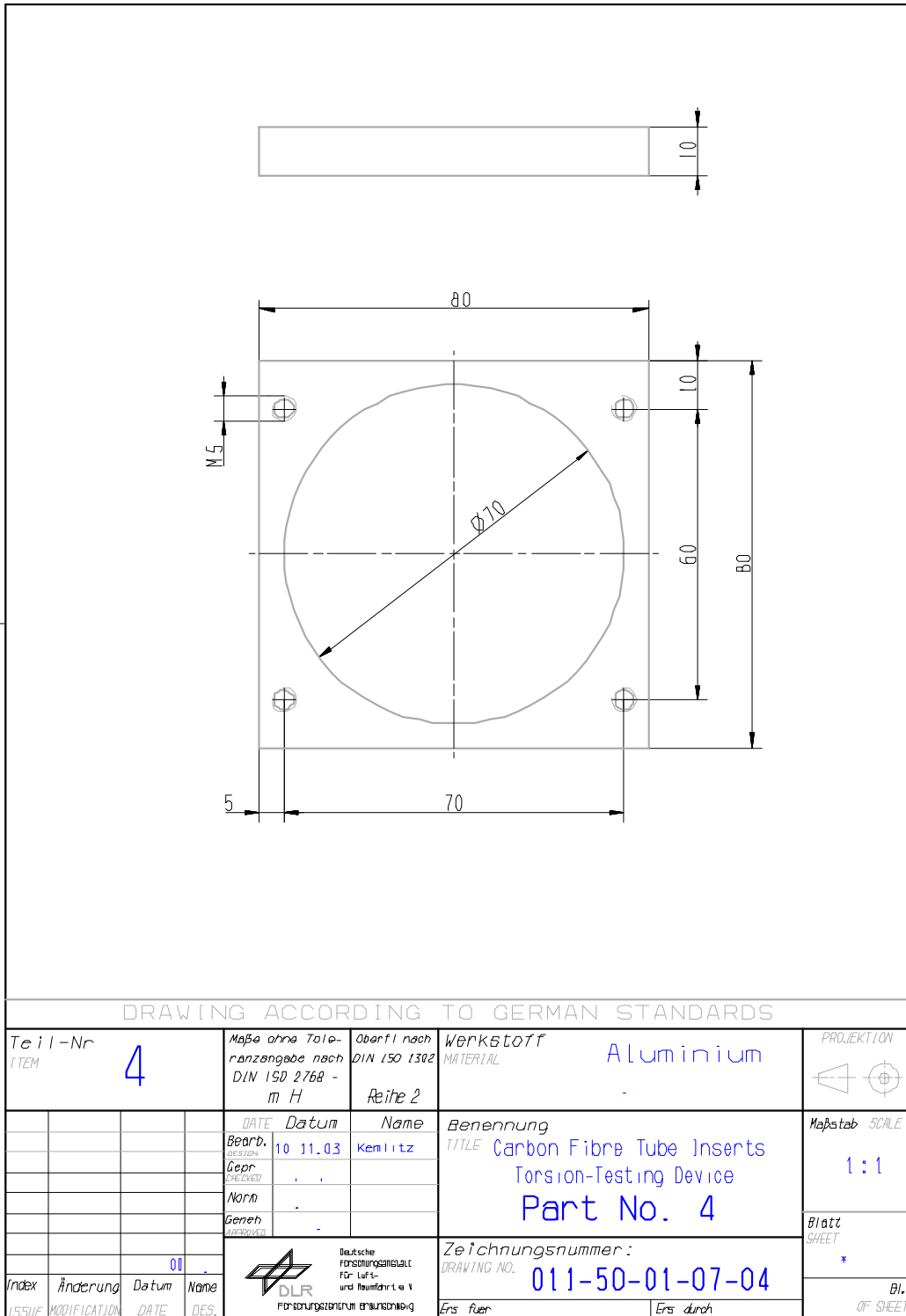

Figure H-35: Test fixture: Torsion – part 4

H.5.1.6 Part 5

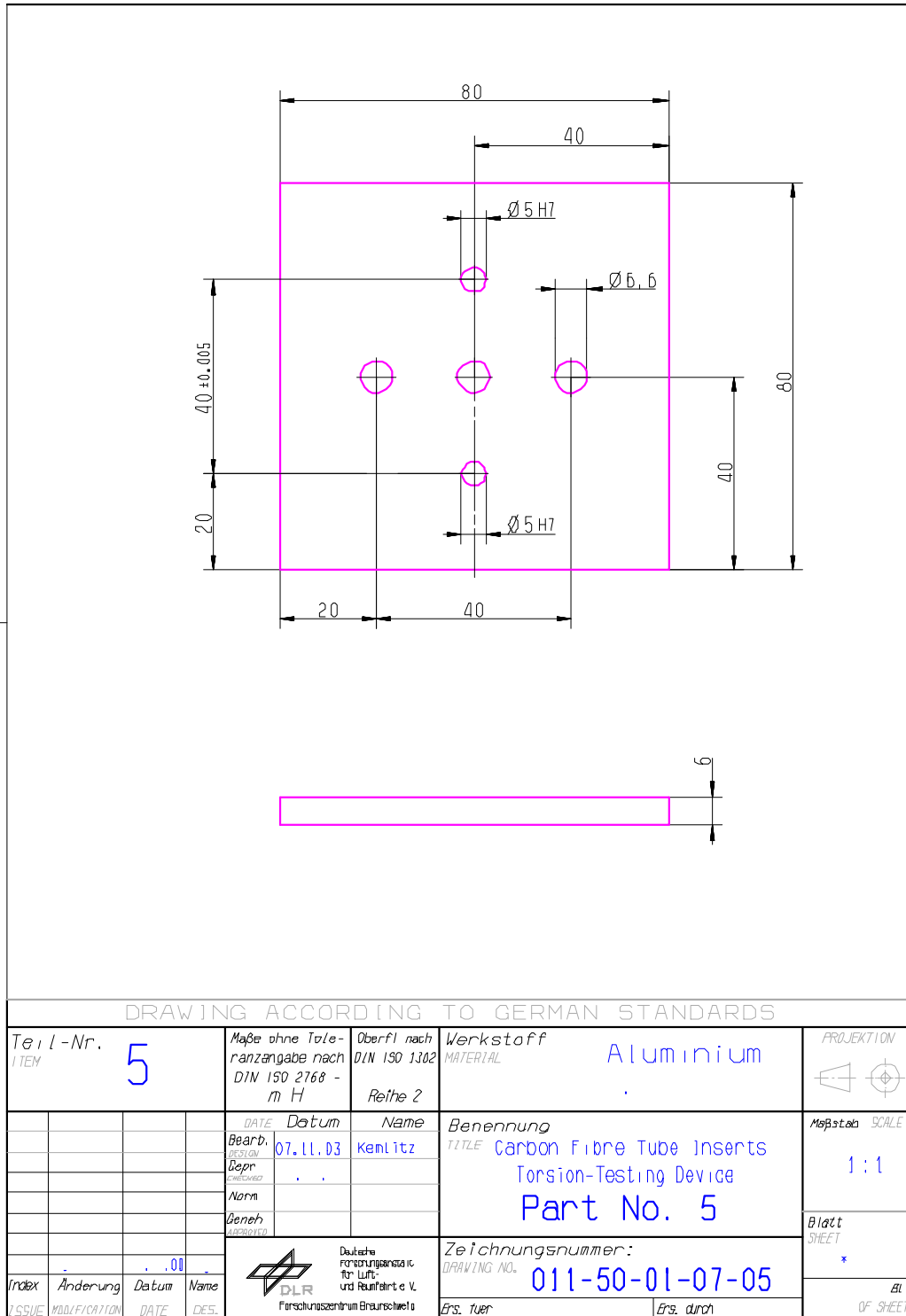
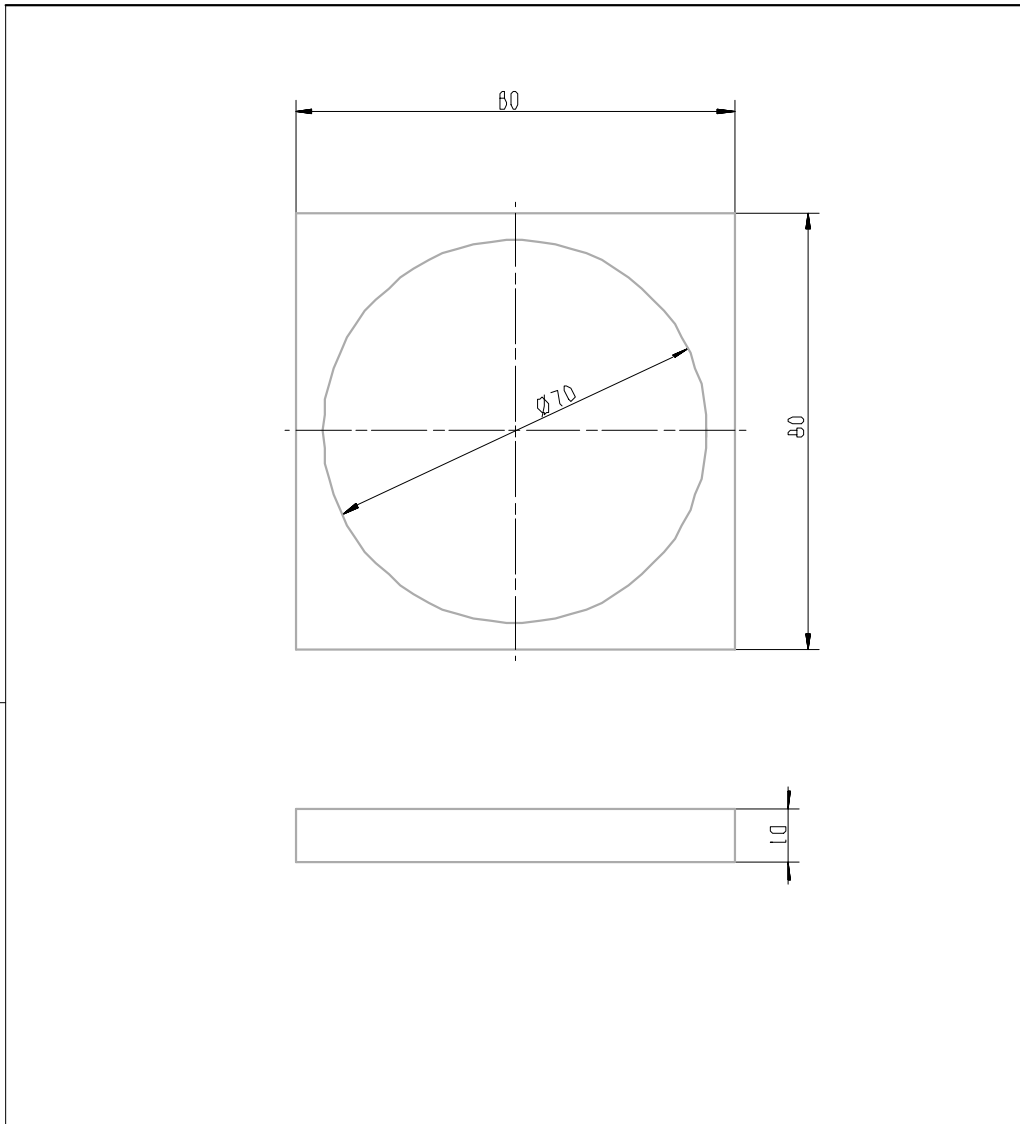

Figure H-36: Test fixture: Torsion – part 5

H.5.1.7 Part 6



DRAWING ACCORDING TO GERMAN STANDARDS											
Teil-Nr. ITEM		6		Maße ohne Toleranzangabe nach DIN ISO 2768 - m H		Oberfl. nach DIN ISO 1302 Reihe 2		Verkstoff MATERIAL		Aluminium	PROJEKTION
				DATE Datum		Name		Benennung TITLE		Maßstab SCALE	
				07.11.03		Kemnitz		Carbon Fibre Tube Inserts Torsion-Testing Device Part No. 6		1:1	
				Gepr. CHECKED						Blatt SHEET	
				Norm						*	
				Geneh. APPROVED				Zeichnungsnummer: DRAWING NO.		Bl. OF SHEET	
				.00				011-50-01-07-06			
Index ISSUE	Anderung MODIFICATION	Datum DATE	Name DES	Deutsche Forschungsanstalt für Luft- und Raumfahrt e.V. Forschungszentrum Braunschweig				Ers. fuer		Ers. durch	

Figure H-37: Test fixture: Torsion – part 6

H.5.1.8 Part 7

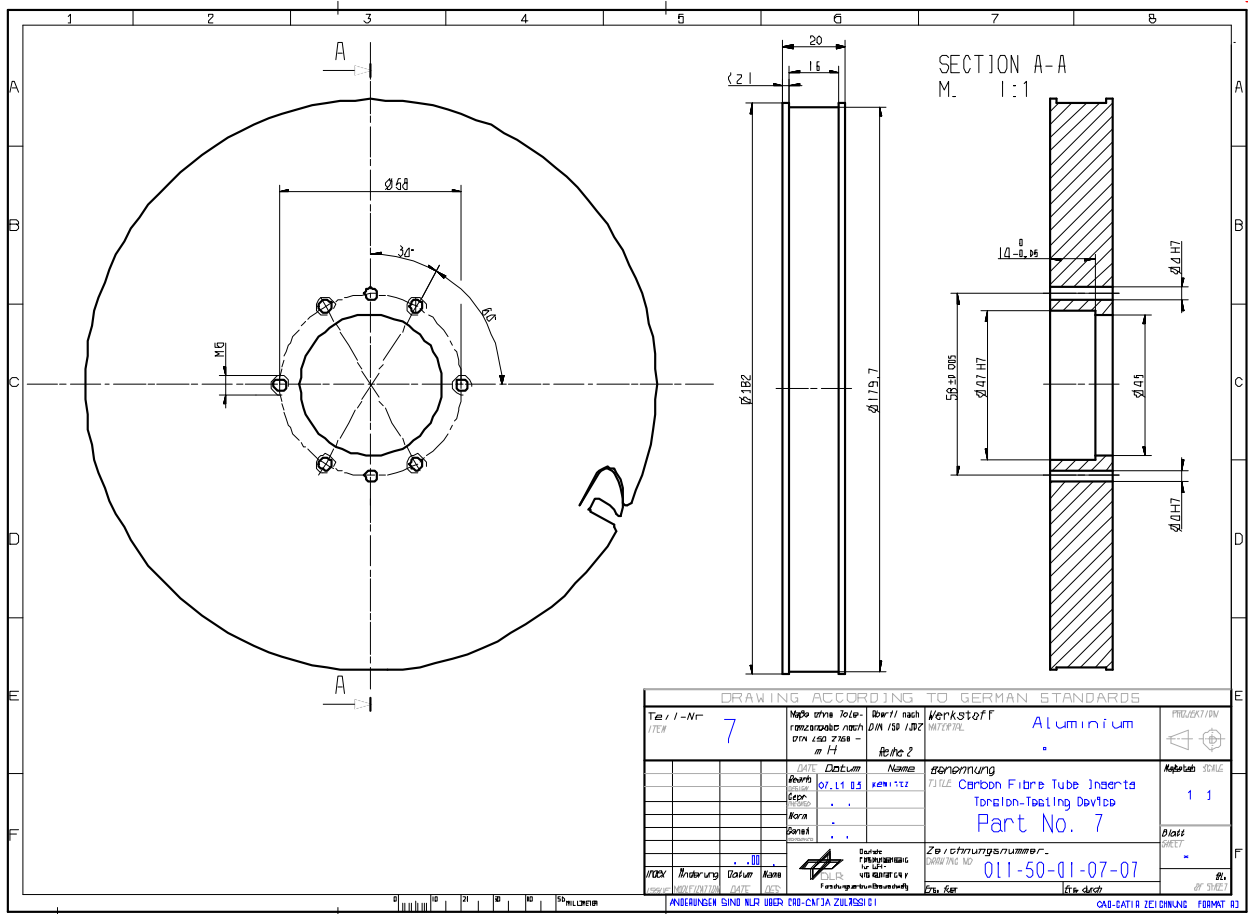
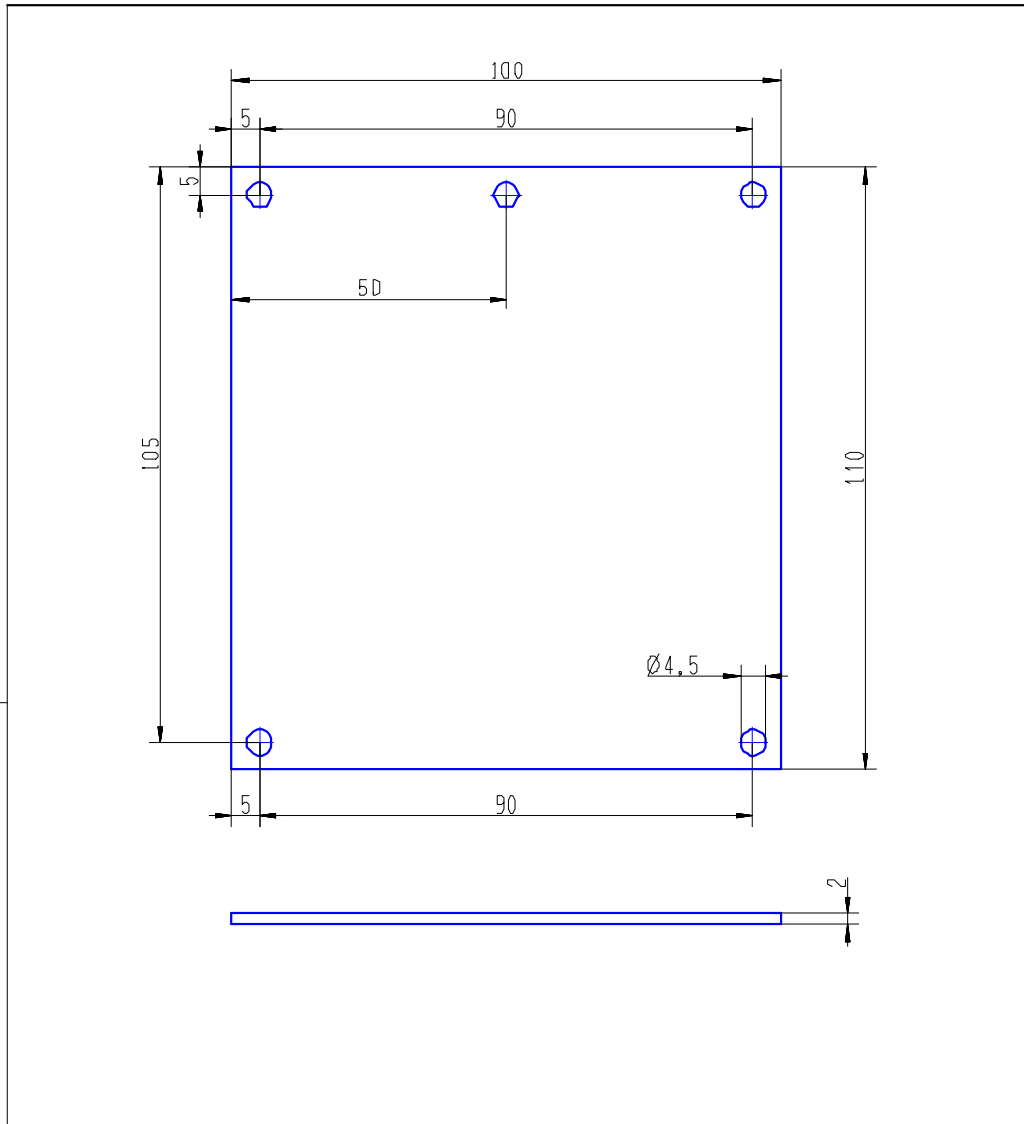

Figure H-38: Test fixture: Torsion – part 7

H.5.1.10 Part 9



DRAWING ACCORDING TO GERMAN STANDARDS							
Teil-Nr. ITEM	9		Maße ohne Toleranzangabe nach DIN ISO 2168 - m H	Überfl nach DIN ISO 1302 Reihe 2	Werkstoff MATERIAL	Aluminium	PROJEKTION
			DATE Datum	Name	Benennung TITLE	Maßstab SCALE	
			Bearb. 07 11 03	Kemnitz	Carbon Fibre Tube Inserts Torsion-Testing Device Part No. 9	1 1	
			Gepr. -				Blatt SHEET
			Norm ..				*
			Geneh. ..				Bl OF SHEET
Index ISSUE	Anderung MODIFICATION	Datum DATE	Name DES	Deutsche Forschungsanstalt für Luft- und Raumfahrt e.V. Forschungszentrum Braunschweig		Zeichnungsnummer. DRAWING NO	011-50-01-07-09
				Ers. über	Ers. durch		

Figure H-40: Test fixture: Torsion – part 9

H.5.1.11 Part 10

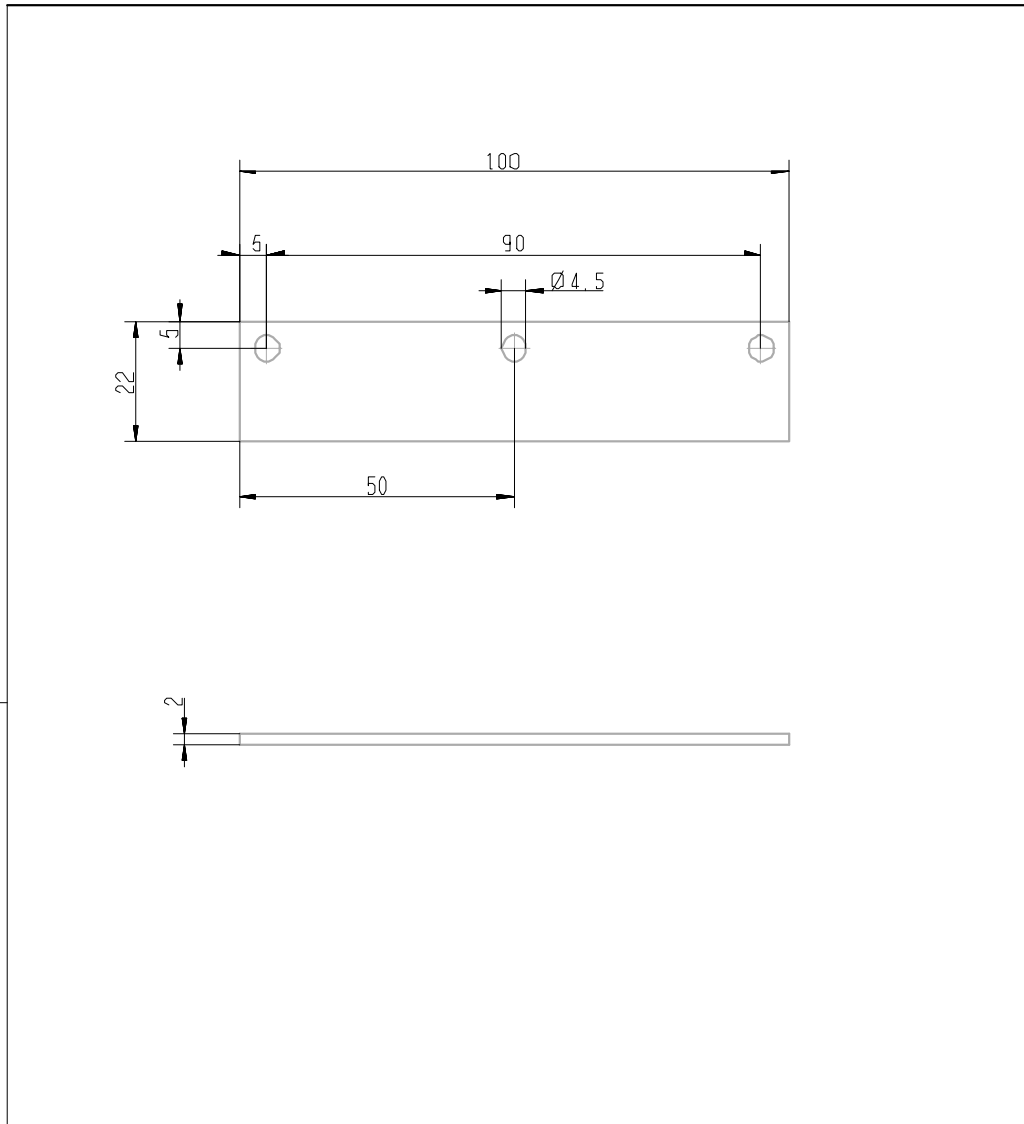

DRAWING ACCORDING TO GERMAN STANDARDS							
Teil-Nr ITEM	10		Maße ohne Toleranzangabe nach DIN 150 2768 - m H	Oberfl.nach DIN 150 1302 Reihe 2	Werkstoff MATERIAL	Aluminium	PROJEKTION
			DATE Datum	Name	Benennung TITLE	Maßstab SCALE	
			Bearb. DESIGNED	07.11.03	Kemnitz	Carbon Fibre Tube Inserts Torsion-Testing Device Part No. 10	1:1
			Gepr. CHECKED	.	.		
			Norm	.			
			Gemeinh. APPROVED	.			Blatt SHEET
							*
Index	Änderung	Datum	Name	Deutsche Forschungsanstalt für Luft- und Raumfahrt e.V. Forschungszentrum Braunschweig		Zeichnungsnummer: DRAWING NO	Bl.
ISSUE	MODIFICATION	DATE	DES			Ers. für	Ers. durch
						011-50-01-07-10	

Figure H-41: Test fixture: Torsion – part 10

H.5.1.12 Part 11

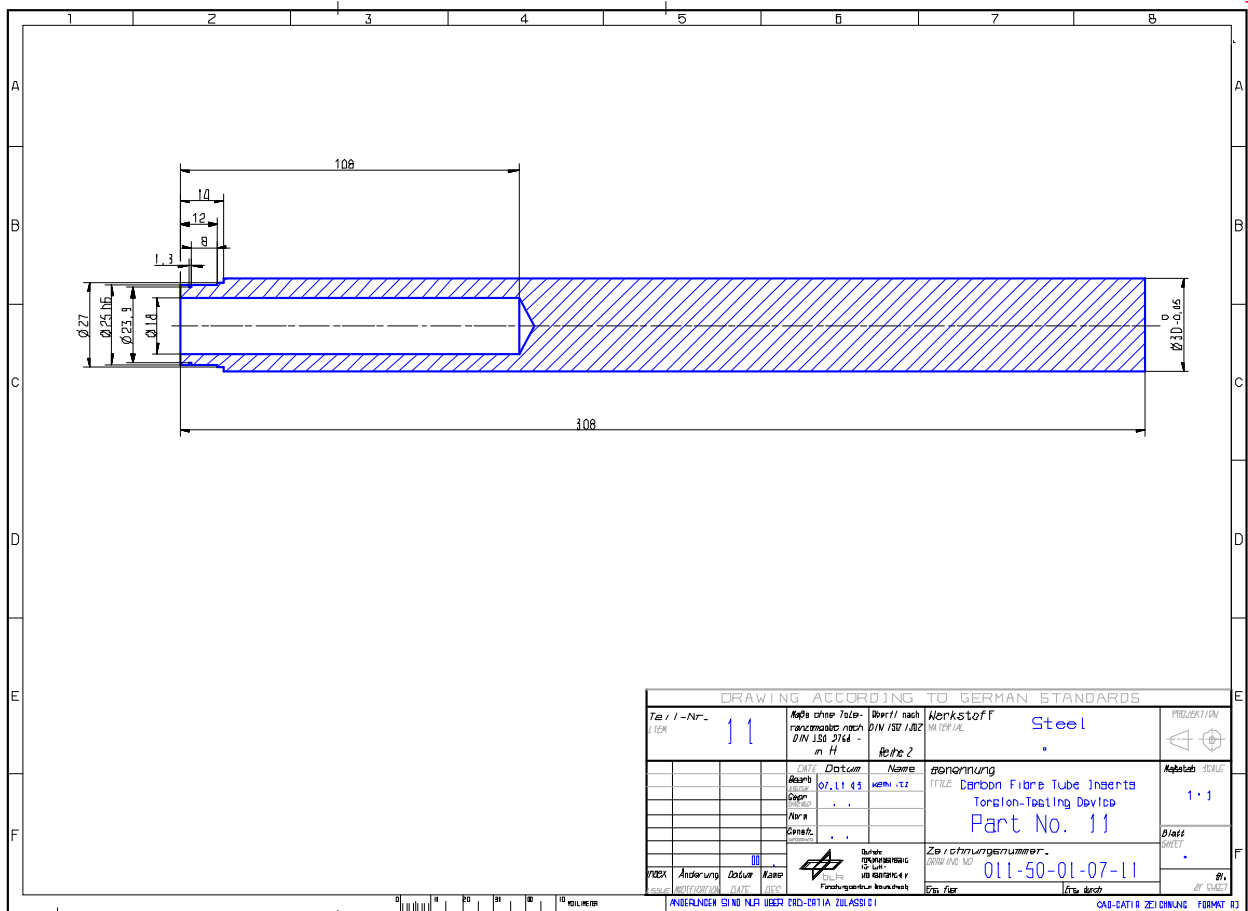

Figure H-42: Test fixture: Torsion – part 11

H.5.1.13 Part 12

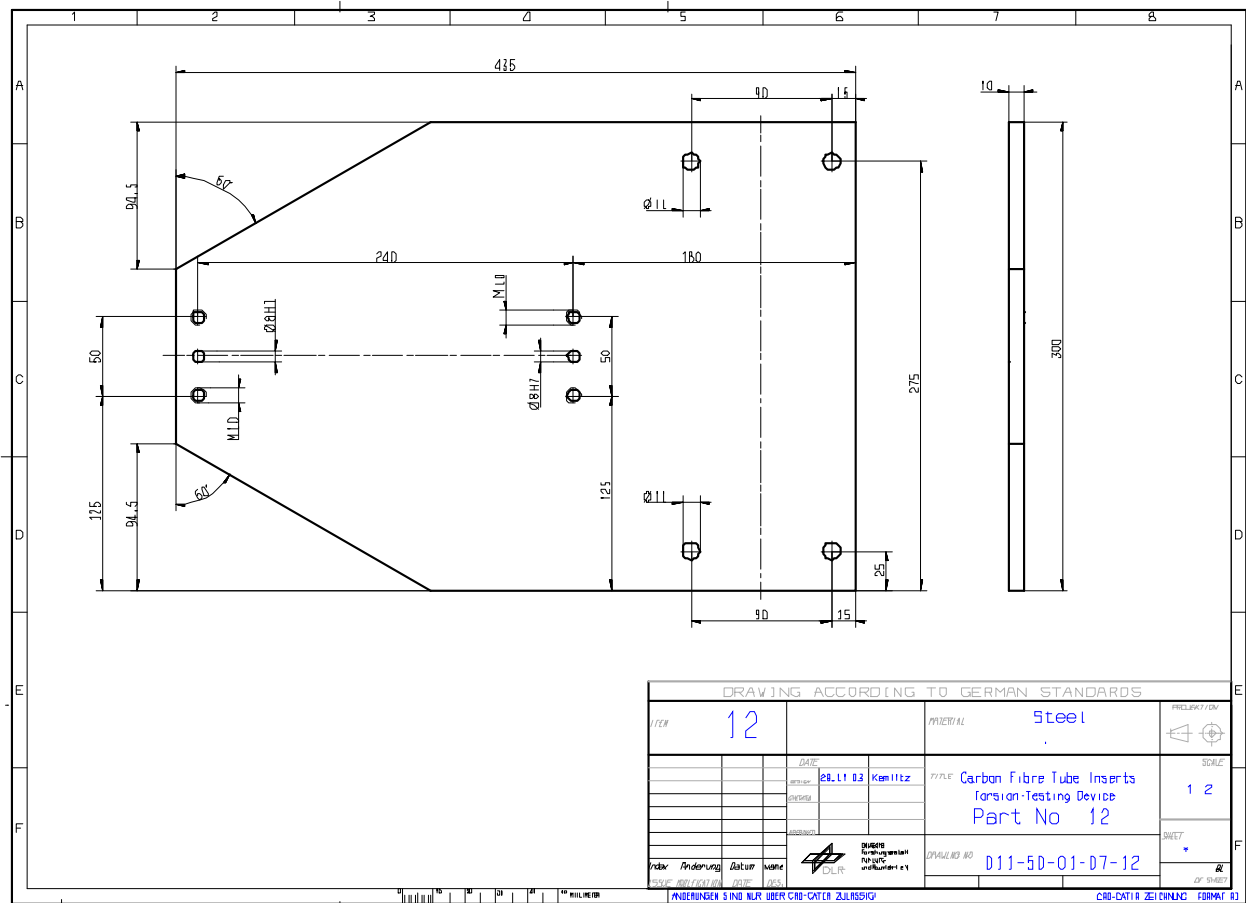

Figure H-43: Test fixture: Torsion – part 12

H.5.1.14 Part 13

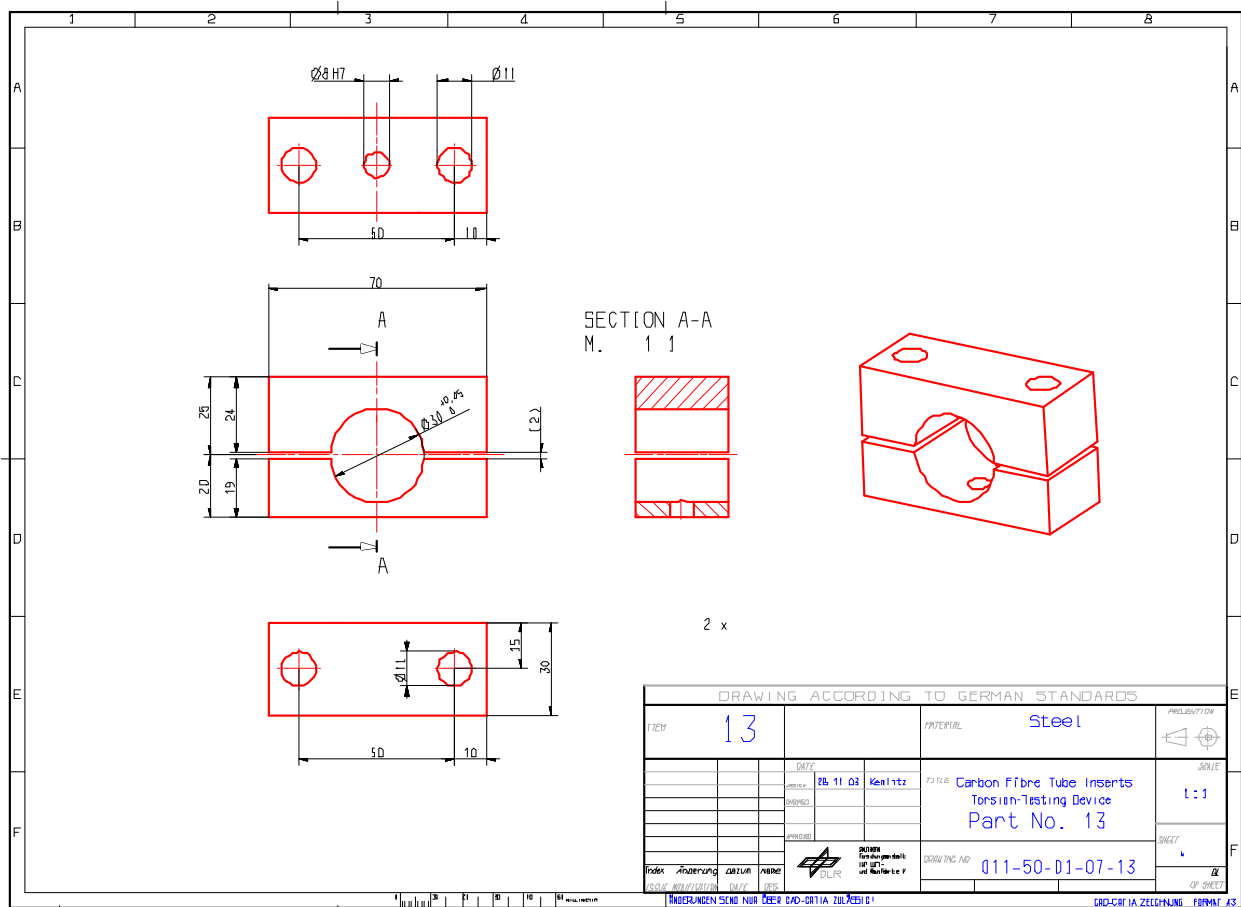

Figure H-44: Test fixture: Torsion – part 13

H.5.1.15 Part 14

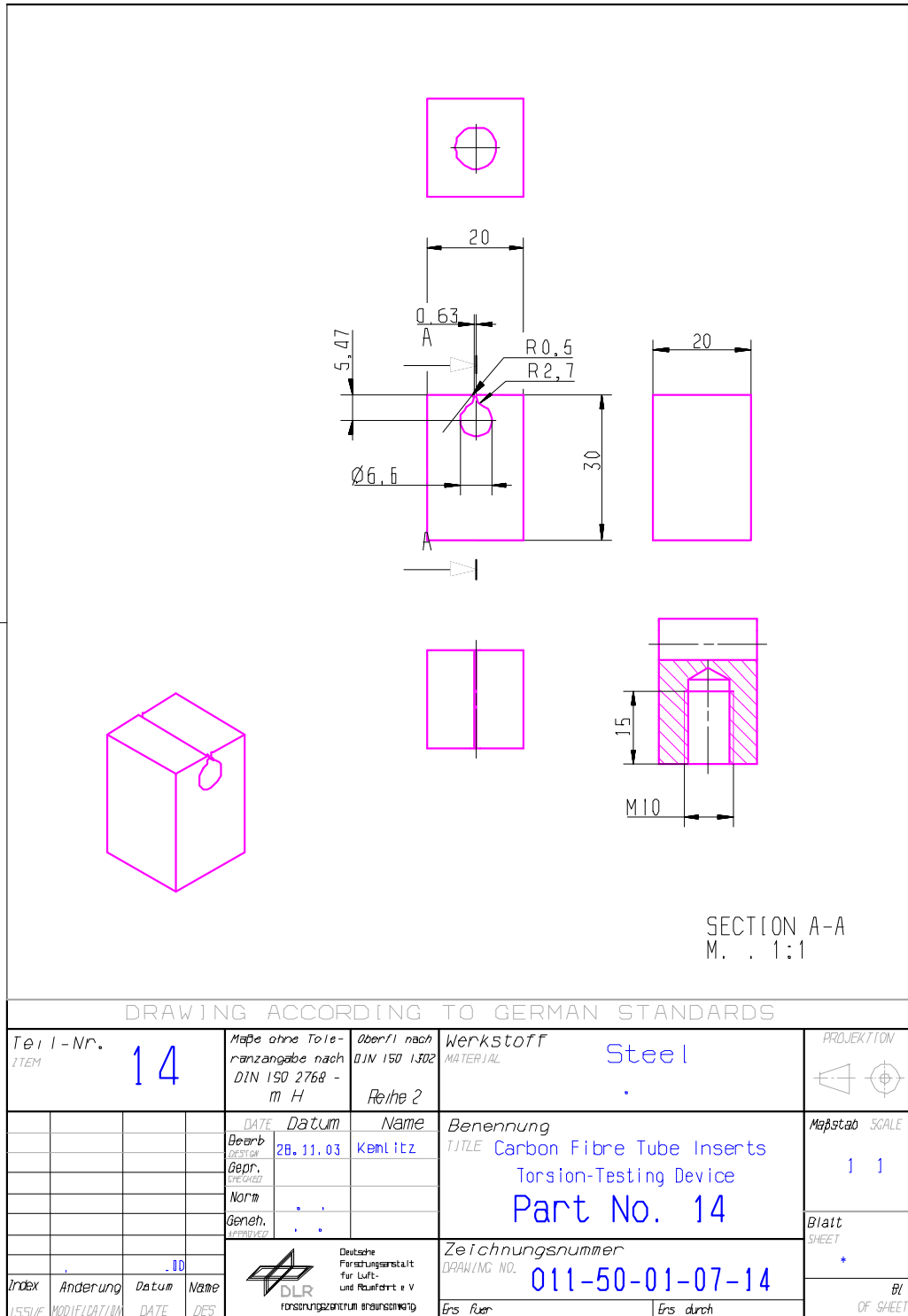

Figure H-45: Test fixture: Torsion – part 14

H.5.1.16 Part 15

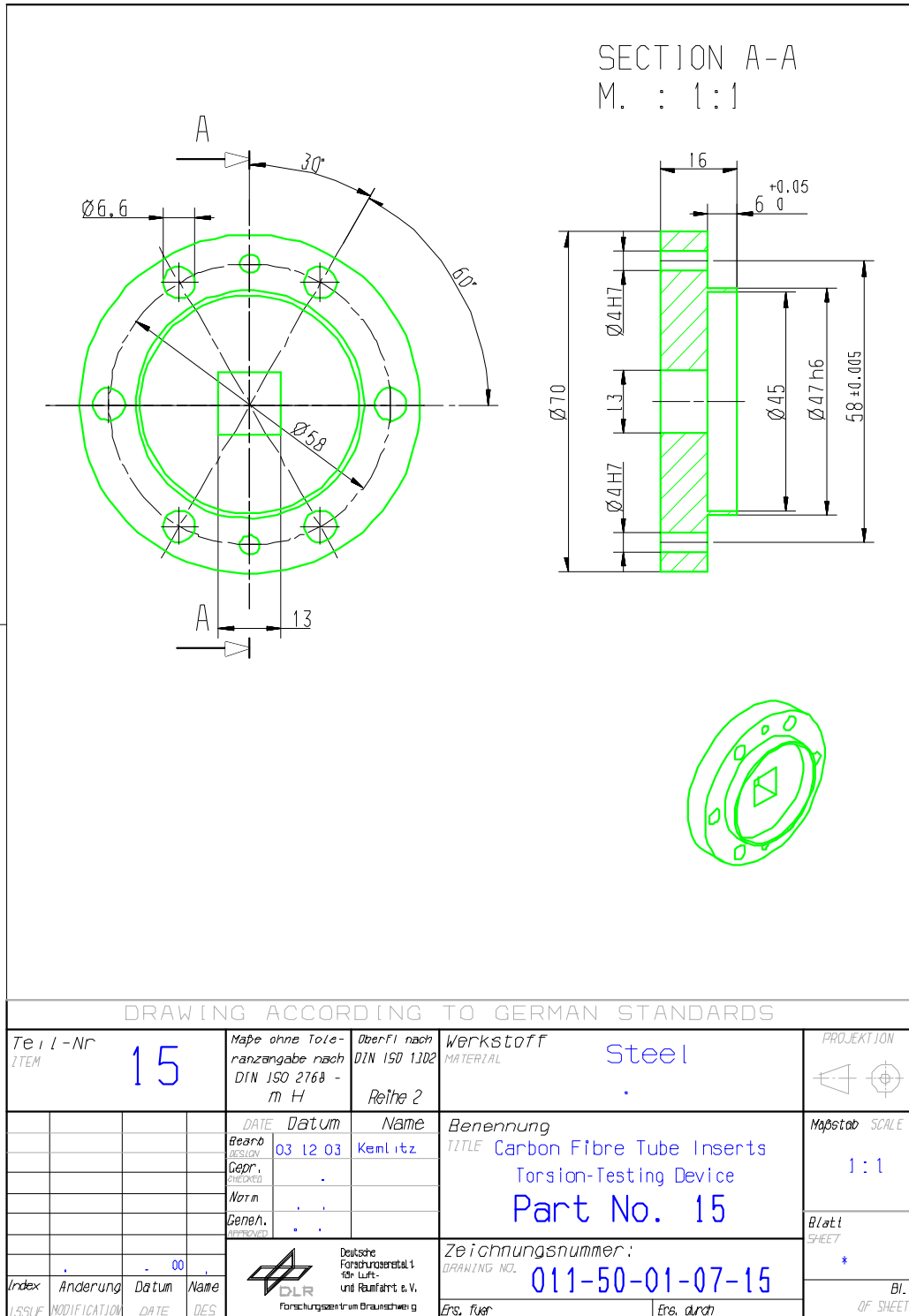

Figure H-46: Test fixture: Torsion – part 15

H.5.1.17 Part 16

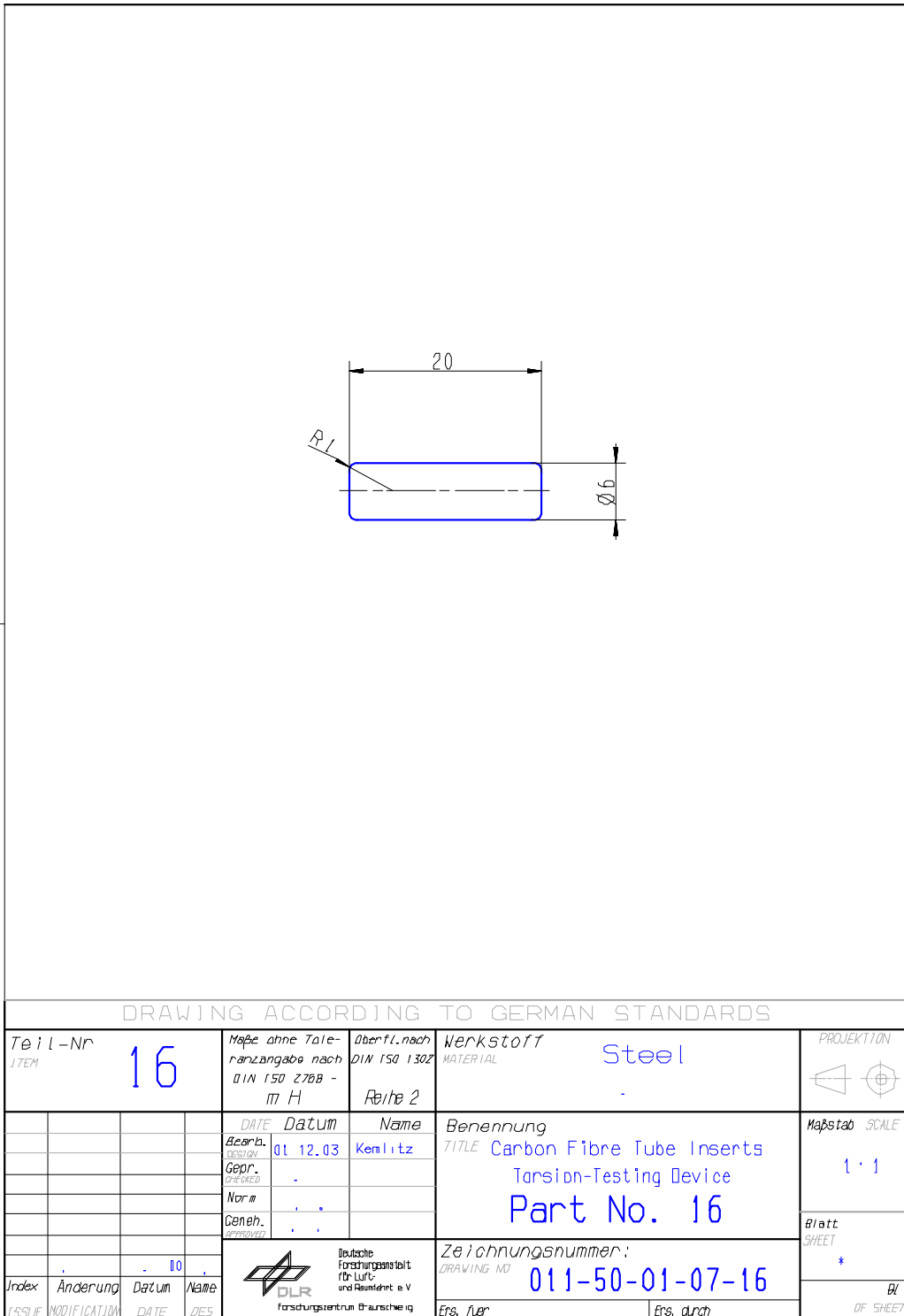

Figure H-47: Test fixture: Torsion – part 16

H.5.1.18 Part 17

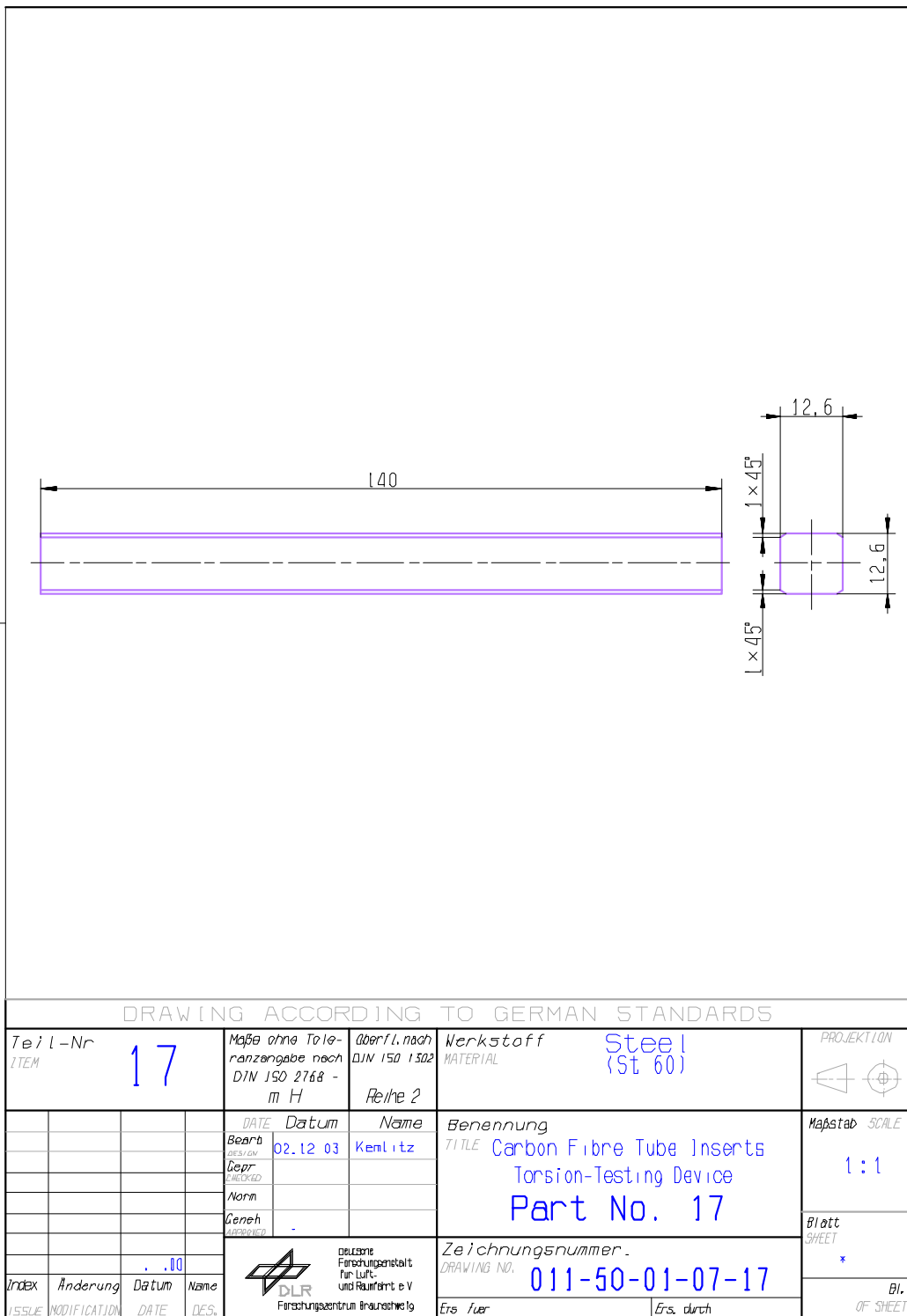

Figure H-48: Test fixture: Torsion – part 17

H.6 References

H.6.1 General

- [29-35] J. Block, R. Schütze, T. Brander, K. Marjoniemi, L. Syvänen, M. Lambert:
DLR Braunschweig/Helsinki Univ. Technology/ Patria/ESTEC
'Study on Carbon Fibre Tube Inserts',
ESTEC Contract No. 16822/02/NL/PA (2004)