

DOT/FAA/AR-00/12

Office of Aviation Research
Washington, D.C. 20591

Aircraft Materials Fire Test Handbook

April 2000

Final Report

This document is available to the U.S. public
through the National Technical Information
Service (NTIS), Springfield, Virginia 22161.



U.S. Department of Transportation
Federal Aviation Administration

NOTICE

This document is disseminated under the sponsorship of the U.S. Department of Transportation in the interest of information exchange. The United States Government assumes no liability for the contents or use thereof. The United States Government does not endorse products or manufacturers. Trade or manufacturer's names appear herein solely because they are considered essential to the objective of this report. This document does not constitute FAA certification policy. Consult your local FAA aircraft certification office as to its use.

This report is available at the Federal Aviation Administration William J. Hughes Technical Center's Full-Text Technical Reports page: www.actlibrary.tc.faa.gov in Adobe Acrobat portable document format (PDF).

1. Report No. DOT/FAA/AR-00/12	2. Government Accession No.	3. Recipient's Catalog No.	
4. Title and Subtitle AIRCRAFT MATERIALS FIRE TEST HANDBOOK	5. Report Date April 2000		6. Performing Organization Code
	8. Performing Organization Report No.		
7. Author(s) Compiled by April Horner	10. Work Unit No. (TRAIS)		
9. Performing Organization Name and Address Federal Aviation Administration Fire Safety Section, AAR-422 William J. Hughes Technical Center Atlantic City International Airport New Jersey 08405	11. Contract or Grant No.		
	13. Type of Report and Period Covered Final Report		
12. Sponsoring Agency Name and Address U.S. Department of Transportation Federal Aviation Administration Office of Aviation Research Washington, DC 20591	14. Sponsoring Agency Code ANM-100		
15. Supplementary Notes This handbook provides information supplemental to any presently available applicable Advisory Circulars. The FAA William J. Hughes Technical Center Monitor was Richard Hill.			
16. Abstract The purpose of the Aircraft Materials Fire Test Handbook is to describe all FAA-required fire test methods for aircraft materials in a consistent and detailed format. The handbook provides information to enable the user to assemble and properly use the test methods. Moreover, to broaden the utility of the handbook, the appendices contain the following information: FAA fire safety regulations, FAA approval process, aircraft materials, regulatory methodology used by other countries, aircraft industry internal test methods and guidelines, laboratories actively using fire test methods, and commercial manufacturers of fire test equipment.			
17. Key Words Fire Safety, Aircraft interior materials, Flammability		18. Distribution Statement This document is available to the public through the National Technical Information Service (NTIS) Springfield, Virginia 22161.	
19. Security Classif. (of this report) Unclassified	20. Security Classif. (of this page) Unclassified	21. No. of Pages 234	22. Price

CONTENTS

	Page
EXECUTIVE SUMMARY	xv
1.0 VERTICAL BUNSEN BURNER TEST FOR CABIN AND CARGO COMPARTMENT MATERIALS	1-1
1.1 Scope	1-1
1.2 Definitions	1-1
1.3 Test Apparatus	1-1
1.4 Test Specimens	1-4
1.5 Conditioning	1-4
1.6 Procedure	1-5
1.7 Report	1-6
1.8 Requirements	1-6
CHAPTER 1 SUPPLEMENT	1-7
2.0 45-DEGREE BUNSEN BURNER TEST FOR CARGO COMPARTMENT LINERS AND WASTE STOWAGE COMPARTMENT MATERIALS	2-1
2.1 Scope	2-1
2.2 Definitions	2-1
2.3 Test Apparatus	2-1
2.4 Test Specimens	2-4
2.5 Conditioning	2-5
2.6 Procedure	2-5
2.7 Report	2-6
2.8 Requirements	2-7
CHAPTER 2 SUPPLEMENT	2-8
3.0 HORIZONTAL BUNSEN BURNER TEST FOR CABIN, CARGO COMPARTMENT, AND MISCELLANEOUS MATERIALS	3-1
3.1 Scope	3-1
3.2 Definitions	3-1
3.3 Apparatus	3-1
3.4 Test Specimens	3-4
3.5 Conditioning	3-5
3.6 Procedure	3-5
3.7 Report	3-6
3.8 Requirements	3-6
CHAPTER 3 SUPPLEMENT	3-7
4.0 60-DEGREE BUNSEN BURNER TEST FOR ELECTRIC WIRE	4-1
4.1 Scope	4-1
4.2 Definitions	4-1
4.3 Apparatus	4-1
4.4 Test Specimens	4-3
4.5 Conditioning	4-3
4.6 Procedure	4-4
4.7 Report	4-4
4.8 Requirements	4-5
CHAPTER 4 SUPPLEMENT	4-6
5.0 HEAT RELEASE RATE TEST FOR CABIN MATERIALS	5-1
5.1 Scope	5-1
5.2 Definitions	5-1

	5.3	Test Apparatus	5-1
	5.4	Test Specimens	5-8
	5.5	Conditioning	5-8
	5.6	Calibration	5-9
	5.7	Test Procedure	5-10
	5.8	Report	5-11
	5.9	Requirements	5-11
		CHAPTER 5 SUPPLEMENT	5-12
6.0		SMOKE TEST FOR CABIN MATERIALS	6-1
	6.1	Scope	6-1
	6.2	Definitions	6-1
	6.3	Test Apparatus	6-1
	6.4	Test Specimen Selection and Preparation	6-10
	6.5	Specimen Conditioning	6-11
	6.6	Test Chamber Calibration	6-11
	6.7	Test Procedure	6-12
	6.8	Report	6-13
	6.9	Requirements	6-13
		CHAPTER 6 SUPPLEMENT	6-14
7.0		OIL BURNER TEST FOR SEAT CUSHIONS	7-1
	7.1	Scope	7-1
	7.2	Definitions	7-1
	7.3	Apparatus	7-1
	7.4	Test Specimens	7-6
	7.5	Specimen Conditioning	7-8
	7.6	Preparation of Apparatus	7-8
	7.7	Calibration	7-9
	7.8	Test Procedure	7-9
	7.9	Report	7-10
	7.10	Requirements	7-10
		CHAPTER 7 SUPPLEMENT	7-11
8.0		OIL BURNER TEST FOR CARGO LINERS	8-1
	8.1	Scope	8-1
	8.2	Definitions	8-1
	8.3	Apparatus	8-1
	8.4	Test Specimen(s)	8-6
	8.5	Specimen Conditioning	8-6
	8.6	Preparation of Apparatus	8-6
	8.7	Calibration	8-7
	8.8	Procedure	8-7
	8.9	Report	8-8
	8.10	Requirements	8-8
		CHAPTER 8 SUPPLEMENT	8-9
9.0		RADIANT HEAT TESTING OF EVACUATION SLIDES, RAMPS, AND RAFTS	9-1
	9.1	Scope	9-1
	9.2	Definition	9-1
	9.3	Test Apparatus	9-1
	9.4	Test Specimens	9-3
	9.5	Conditioning	9-3
	9.6	Calibration	9-3
	9.7	Procedure	9-4

	9.8 Report	9-4
	9.9 Requirement	9-4
	CHAPTER 9 SUPPLEMENT	9-5
10.0	FIRE CONTAINMENT TEST OF WASTE STOWAGE COMPARTMENTS	10-1
	10.1 Scope	10-1
	10.2 Definitions	10-1
	10.3 Test Apparatus/Equipment	10-2
	10.4 Test Unit	10-3
	10.5 Test Arrangements	10-3
	10.6 Procedure	10-4
	10.7 Report	10-6
	10.8 Requirements	10-7
	CHAPTER 10 SUPPLEMENT	10-8
11.0	POWERPLANT HOSE ASSEMBLIES TEST	11-1
	11.1 Scope	11-1
	11.2 Definitions	11-1
	11.3 Apparatus	11-1
	11.4 Test Specimens	11-10
	11.5 Calibration	11-10
	11.6 Procedure	11-11
	11.7 Report	11-12
	11.8 Requirements	11-12
	CHAPTER 11 SUPPLEMENT	11-13
12.0	POWERPLANT FIRE PENETRATION TEST	12-1
	12.1 Scope	12-1
	12.2 Definitions	12-1
	12.3 Apparatus	12-1
	12.4 Test Specimens	12-3
	12.5 Conditioning	12-3
	12.6 Calibration	12-3
	12.7 Procedure	12-4
	12.8 Report	12-4
	12.9 Requirements	12-5
	CHAPTER 12 SUPPLEMENT	12-6
13.0	TEST FOR ELECTRICAL CONNECTORS USED IN FIREWALLS	13-1
	13.1 Scope	13-1
	13.2 Definitions	13-1
	13.3 Apparatus	13-1
	13.4 Test Specimens	13-2
	13.5 Procedure	13-5
	13.6 Report	13-7
	13.7 Requirements	13-7
	CHAPTER 13 SUPPLEMENT	13-8
14.0	TEST FOR ELECTRICAL WIRE USED IN DESIGNATED FIRE ZONES	14-1
	14.1 Scope	14-1
	14.2 Definitions	14-1
	14.3 Apparatus	14-1
	14.4 Test Specimens	14-4
	14.5 Conditioning/Preparation of Test Specimens	14-4
	14.6 Calibration	14-5

14.7	Procedure	14-5
14.8	Report	14-6
14.9	Requirements	14-7
	CHAPTER 14 SUPPLEMENT	14-8
15.0	TWO GALLON PER HOUR OIL BURNER CERTIFICATION TESTING FOR REPAIRED CARGO COMPARTMENT LINERS	15-1
15.1	Scope	15-1
15.2	Test Specimens	15-1
15.3	Specimen Conditioning	15-3
15.4	Procedure	15-3
15.5	Report	15-4
15.6	Requirements	15-5
16.0	RESERVED	16-1
17.0	RESERVED	17-1
18.0	RECOMMENDED PROCEDURE FOR THE 4-PLY HORIZONTAL FLAMMABILITY TEST FOR AIRCRAFT BLANKETS	18-1
18.1	Scope	18-1
18.2	Definitions	18-1
18.3	Test Apparatus	18-1
18.4	Test Specimens	18-4
18.5	Conditioning	18-4
18.6	Procedure	18-4
18.7	Report	18-5
18.8	Requirements	18-6
	CHAPTER 18 SUPPLEMENT	18-7
19.0	SMOKE TEST FOR INSULATED AIRCRAFT WIRE	19-1
19.1	Scope	19-1
19.2	Definitions	19-1
19.3	Test Apparatus	19-1
19.4	Test Specimen Selection and Preparation	19-10
19.5	Test Chamber Calibration	19-12
19.6	Procedure	19-13
19.7	Report	19-14
	CHAPTER 19 SUPPLEMENT	19-15
20.0	DRY ARC TRACKING TEST PROCEDURE	20-1
20.1	Purpose	20-1
20.2	Test Specimens	20-1
20.3	Procedure	20-2
20.4	Report	20-2
21.0	DRY ARC-PROPAGATION RESISTANCE	21-1
21.1	Purpose	21-1
21.2	Test Equipment	21-1
21.3	Test Samples	21-2
21.4	Procedure	21-2
21.5	Results	21-5
21.6	Information Required in the Individual Specification	21-6
22.0	COTTON SWAB TEST FOR THERMAL ACOUSTIC INSULATION BLANKETS	22-1
22.1	Scope	22-1
22.2	Definitions	22-1

22.3	Test Apparatus	22-1
22.4	Test Specimens	22-1
22.5	Test Procedure	22-2
22.6	Report	22-2
22.7	Requirements	22-2
APPENDIX A: FAA REGULATIONS		A-1
A.1	A Brief History of Federal Agencies Regulating Aviation	A-1
A.2	Organization of the FAA	A-2
A.3	Enabling Legislation and Procedures for the FAA	A-4
A.4.	Documentary Sources for Flammability Requirements	A-8
APPENDIX B: THE APPROVAL PROCESS		B-1
B.1	Introduction	B-1
B.2	Approval Steps Manufacturers	B-1
B.3	Approval Steps—Operators	B-10
APPENDIX C: MATERIALS USED IN AIRCRAFT		C-1
C.1	Introduction	C-1
C.2	Aircraft Seats	C-1
C.3	Insulating Materials	C-2
C.4	Interior Panel Structures	C-3
C.5	Floor Coverings	C-5
C.6	Draperies	C-6
C.7	Nonmetallic Air Ducting	C-6
C.8	Linings (Nonpanel)	C-6
C.9	Electrical Components	C-7
C.10	Firewalls	C-7
C.11	Windows	C-7
C.12	Small Parts	C-8
APPENDIX D: REGULATORY METHODOLOGY USED BY OTHER COUNTRIES		D-1
D.1	Introduction	D-1
D.2	Foreign Airworthiness Authorities and Regulations	D-1
D.3	Regulations Covering Foreign Air Carriers	D-1
D.4	Certification of Foreign-Manufactured Aircraft	D-1
APPENDIX E: AIRCRAFT INDUSTRIES INTERNAL TEST METHODS AND GUIDELINES		E-1
APPENDIX F: LABORATORIES ACTIVELY USING FIRE TEST PROCEDURES		F-1
APPENDIX G: COMMERCIAL MANUFACTURERS OF FIRE TEST EQUIPMENT		G-1

LIST OF ILLUSTRATIONS

Figure		Page
1-1	Sketch of Vertical Bunsen Burner Test Cabinet	1-2
1-2	Front and Top View of Vertical Bunsen Burner Test Cabinet	1-2
1-3	Vertical Bunsen Burner Test Specimen Holder	1-3
1-4	Burner Plumbing and Burner Flame Height Indicator	1-3
1-5	Flame Position on Vertical Specimens	1-5
2-1	Sketch of 30-Second, 45-Degree Bunsen Burner Test Cabinet	2-2
2-2	Front and Top View of 30-Second, 45-Degree Bunsen Burner Test Cabinet	2-2
2-3	Side Views of 30-Second, 45-Degree Bunsen Burner Test Cabinet	2-3
2-4	30-Second, 45-Degree Bunsen Burner Test Specimen Frame and Stand	2-3
2-5	Burner Plumbing and Burner Flame Height Indicator	2-4
2-6	Flame Position on 30-Second, 45-Degree Bunsen Burner Test Specimen	2-6
3-1	Sketch of Horizontal Bunsen Burner Test Cabinet	3-1
3-2	Front and Top View of Horizontal Bunsen Burner Test Cabinet	3-2
3-3	Side View of Horizontal Bunsen Burner Test Cabinet	3-2
3-4	Horizontal Bunsen Burner Test Specimen Holder	3-3
3-5	Burner Plumbing and Burner Flame Height Indicator	3-4
3-6	Typical Burner and Specimen Location	3-5
4-1	60-Degree Electrical Wire Bunsen Burner Test Setup	4-2
4-2	Burner Plumbing and Burner Flame Height Indicator	4-3
4-3	Alternative Setup for 60-Degree Electrical Wire Bunsen Burner Test	4-7
5-1a	Rate of Heat Release Apparatus	5-2
5-1b	Rate of Heat Release Apparatus	5-3
5-2	Thermopile	5-4
5-3	Side View—Global Radiant Heat Panel	5-5
5-4	Heat Release Specimen Holder, Mounting Bracket, and Drip Pan	5-6
5-5	Lower Pilot Burner Igniter Schematic	5-7
5-6	Upper Pilot Burner - 15 Hole Burner	5-7
5-7	Typical Calibration Burner	5-9
6-1	Typical Smoke Density Chamber	6-1
6-2	Furnace Section	6-3
6-3	Heater Orientation	6-3
6-4	Alignment of Holder and Burner	6-4
6-5	Flame Size	6-5
6-6	Details of Specimen Holder	6-6
6-7	Typical Furnace Support	6-7
6-8	Photometer Detail	6-8
6-9	Photometer Location	6-9
6-10	Burner Position (Optional)	6-14

7-1	Front, Side, and Top Views of Seat Oil Burner Specimen Frame	7-2
7-2	Top and Side View of Specimen Setup in Test Frame	7-2
7-3a	Burner Cone Layout and Bending Pattern	7-3
7-3b	Burner and Cone Details	7-3
7-4	Illustration for the Location of the Air Velocity Sensor	7-4
7-5	Top and Side Views of Calorimeter Bracket	7-5
7-6	Top and Side Views of Thermocouple Rack Bracket	7-5
7-7	Example of Production Seat Configuration and Test Specimen Set to Substantiate Production Seat Bottom Cushion	7-7
7-8	Specimen Set to Substantiate Production Seat Bottom and Specimen Set to Substantiate Production Seat Back	7-7
7-9	Example of Production Seat Configuration Using Two Dress Cover Materials and Test Specimen Set to Substantiate Dress Cover Combination	7-8
7-10	Static Disk Illustration	7-13
8-1	Test Apparatus for Horizontal and Vertical Mounting for Cargo Liner Oil Burner Testing	8-1
8-2	Cargo Liner Test Specimen Frame	8-2
8-3	Cargo Liner Test Specimen Retaining Frame	8-2
8-4a	Burner Cone Layout and Bending Pattern	8-3
8-4b	Burner Cone Details	8-3
8-5	Top and Side Views of Calorimeter Bracket	8-4
8-6	Top and Side View of Thermocouple Rake Bracket	8-5
8-7	Illustration for the Location of the Air Velocity Sensor	8-6
8-8	Static Disk Illustration	8-10
9-1	Evacuation Slide Material Test Apparatus – Front View	9-1
9-2	Evacuation Slide Material Test Apparatus – Side View	9-2
9-3	Evacuation Slide Material Test Apparatus – Top View	9-2
9-4	Furnace Details	9-2
10-1	Sample Fire Containment Temperature versus Time Plot	10-6
11-1	Burner Extension Funnel	11-5
11-2	Air Tube Reducing Cone	11-5
11-3	Hose Assemblies Test Setup	11-6
11-4	Burner Calibration Standardization Apparatus	11-7
11-5	Btu Heat Transfer Device	11-7
11-6	Btu Heat Transfer Device—Reducer	11-7
11-7	Btu Heat Transfer Device—Inlet Tube	11-8
11-8	Btu Heat Transfer Device—Outlet Tube	11-8
11-9	Btu Heat Transfer Device—Thermometer Mounting	11-8
11-10	Btu Heat Transfer Device—Test Specimen	11-9
12-1	Firewall Penetration Test Setup—Top View	12-2
13-1	Firewall Connector Test Setup	13-3
13-2	Firewall Connector Fixture Assembly	13-4
13-3	Firewall Connector Fixture Details	13-5

13-4	Connector Electrical Integrity Connection Diagram	13-6
14-1	Firezone Electrical Wire Test Setup	14-2
14-2	Burner Details	14-3
14-3	Thermocouple Details	14-3
14-4	Fire Zone Electrical Wire Test Setup—Top View	14-5
14-5	Electrical Connections	14-6
15-1	Cargo Liner Test Specimen Frame	15-2
15-2	Eight- by Eight-Inch Patch Over Standard Damage	15-2
15-3	Overlapped Patches for Shingling Test	15-3
18-1	Sketch of Bunsen Burner Test Cabinet	18-1
18-2	Front and Top View of Bunsen Burner Test Cabinet	18-2
18-3	Side Views of Bunsen Burner Test Cabinet	18-2
18-4	Horizontal Test Fixture	18-3
18-5	Burner Plumbing and Burner Flame Height Indicator	18-3
18-6	Horizontal Test Fixture with Four-Ply Blanket Sample	18-5
19-1	Typical Smoke Density Chamber	19-1
19-2	Furnace Section	19-3
19-3	Heater Orientation	19-3
19-4	Straight Tip Burner	19-4
19-5	Alignment of Holder and Burner	19-5
19-6	Flame Size	19-5
19-7	Details of Specimen Holder	19-6
19-8	Typical Furnace Support	19-7
19-9	Photometer Detail	19-8
19-10	Optical System Location Plan View	19-9
19-11	Wire Holding Frame	19-11
19-12	Larger Gauge Wire Mounted in Specimen Holder	19-11
20-1	Wire Bundle Configuration	20-1
20-2	Electrical Connections	20-2
21-1	Typical Abrader Blade	21-1
21-2	Aluminum Blade Sharpening Fixture	21-2
21-3	Bundle Configuration	21-3
21-4	Test Fixture	21-3
21-5	Electrical Connection	21-4
21-6	Ball-Slide Blade Fixture	21-5
22-1	Cotton Swab Test Configuration	22-2

LIST OF TABLES

Tables	Page
1-1	1-8
4-1	4-2
10-1	10-1
11-1	11-2
11-2	11-11
13-1	13-6
14-1	14-4
21-1	21-4
21-2	21-4

LIST OF ACRONYMS

A	Ampere(s)
AC	Advisory Circular
AC	Alternating Current
ACD	Aircraft Certification Directorate/Division
ACO	Aircraft Certification Office
AD	Airworthiness Directive
ANSI	American National Standards Institute
ASTM	American Society for Testing and Materials
ATC	Air Traffic Control
AWG	American Wire Gauge
BAA	Bilateral Airworthiness Agreement
BCAR	British Civil Airworthiness Requirement
Btu	British Thermal Unit
C	Centigrade
CAA	Civil Aeronautics Administration
CAB	Civil Aeronautics Board
CAMI	Civil Aeromedical Institute
CAR	Civil Air Regulation
CC	Constant Capacity
CFR	Code of Federal Regulations
CL	Center Line
cm	Centimeter(s)
DC	Direct Current
DER	Designated Engineering Representative
DMIR	Designated Manufacturing Inspection Representative
DOT	Department of Transportation
D_s	Specific Optical Density
F	Fahrenheit
FAA	Federal Aviation Administration
FAR	Federal Aviation Regulation
Fe(CO) ₅	Iron pentacarbonyl

FPM	Feet per Minute
FR	Fire-Retarded
FR	Flame Retardant
FSS	Flight Standards Service
FSSR	Flight Standards Service Release
g	Gram(s)
GENOT	General Notice
H ₂ O	Water
Hg	Mercury
HP	Horsepower
Hz	Hertz
ICAO	International Civil Aviation Organization
ID	Inside Diameter
JAR	Joint Airworthiness Regulation
K	Kelvin
kPa	Kilo Pascal(s)
Kv	Kilovolt(s)
kVA	Kilovolt Ampere(s)
kW	Kilowatt(s)
L	Liter
m	Meter
MIDO	Manufacturing Inspection District Office
mil	Milliliter
mm	Millimeter(s)
MPa	Mega Pascal(s)
MPS	Meters per Second
mV	Millivolt(s)
NBS	National Bureau of Standards
NF	National Fine
NIST	National Institute of Standards and Technology
NPRM	Notice of Proposed Rulemaking
NPT	Normal Pressure and Temperature
OD	Outside Diameter
OEM	Original Equipment Manufacturer
PATCO	Professional Air Traffic Controllers Organization
PI	Principal Investigator
PMA	Part Manufacturer Approval
psi	Pounds per Square Inch
psig	Pounds per Square Inch—Gauge
PTFE	Polyethylenetetrafluoroethylene
PVF	Polyvinyl Fluoride
S	Second
SAE	Society of Automotive Engineers
SRR	Safety Regulation Release

STC	Supplemental Type Certificate
STP	Standard Temperature and Pressure
TC	Type Certificate
THD	Thread
TSO	Technical Standard Order
UV	Ultraviolet
V	Volt
W	Watt(s)

EXECUTIVE SUMMARY

In order to assure prescribed levels of fire safety in civil aircraft, the Federal Aviation Administration (FAA) requires that a variety of fire test methods be used to demonstrate that aircraft materials meet specified performance criteria when exposed to heat or flame. In principle, the specific test method required serves as a surrogate for the fire environment to which a given material could potentially be exposed, and the test criteria relate to the performance of the material in this fire environment. This handbook provides information supplemental to any presently available applicable Advisory Circulars.

While a number of fire test requirements are of recent vintage, others have origins in research and development efforts completed many years ago. Because of a span of time during which the various fire test requirements were developed, there is an inevitable wide variation in the accessibility of primary technical documents, in currency of test equipment details, and in style and clarity of technical content.

The purpose of the *Aircraft Materials Fire Test Handbook* is to describe all FAA-required fire test methods for aircraft materials in a consistent and detailed format. The handbook provides information to enable the user to assemble and properly use the test methods. Moreover, to broaden the utility of the handbook, the appendices contain the following information: FAA fire safety regulations, FAA approval process, aircraft materials, regulatory methodology used by other countries, aircraft industry internal test methods and guidelines, laboratories actively using fire test methods, and commercial manufacturers of fire test equipment.

Chapter 1

Vertical Bunsen Burner Test for Cabin and Cargo Compartment Materials

1.1 Scope

This test method is intended for use in determining the resistance of materials to flame when tested according to the 60-second and 12-second Vertical Bunsen Burner Tests specified in Federal Aviation Regulation (FAR) 25.853 and FAR 25.855.

1.2 Definitions

1.2.1 Ignition Time

Ignition time is the length of time the burner flame is applied to the specimen. It can be either 60 seconds or 12 seconds for this test.

1.2.2 Flame Time

Flame time is the time in seconds that the specimen continues to flame after the burner flame is removed from beneath the specimen. Surface burning that results in a glow but not in a flame is not included.

1.2.3 Drip Flame Time

Drip flame time is the time in seconds that any flaming material continues to flame after falling from the specimen to the floor of the chamber. If no material falls from the specimen, the drip flame time is reported to be 0 seconds, and the notation "No Drip" is also reported. If there is more than one drip, the drip flame time reported is that of the longest flaming drip. If succeeding flaming drips reignite earlier drips that flamed, the drip flame time reported is the total of all flaming drips.

1.2.4 Burn Length

Burn length is the distance from the original specimen edge to the farthest evidence of damage to the test specimen due to that area's combustion including areas of partial consumption, charring, or embrittlement but not including areas sooted, stained, warped, or discolored nor areas where material has shrunk or melted away from the heat.

1.3 Test Apparatus

1.3.1 Test Cabinet

Tests will be conducted in a draft-free cabinet fabricated in accordance with figures 1-1 to 1-3 or other equivalent enclosures acceptable to the Federal Aviation Administration (FAA). It is suggested that the cabinet be located inside an exhaust hood to facilitate clearing the cabinet of smoke after each test. Stainless steel or other corrosion-resistant metal 0.04 inch (1 mm) thick will be used for the bottom surface of the chamber.

1.3.2 Specimen Holder

The specimen holder will be fabricated of corrosion-resistant metal in accordance with figure 1-3 or the equivalent. The holder will be able to accommodate specimens up to 1 inch (25 mm) thick.

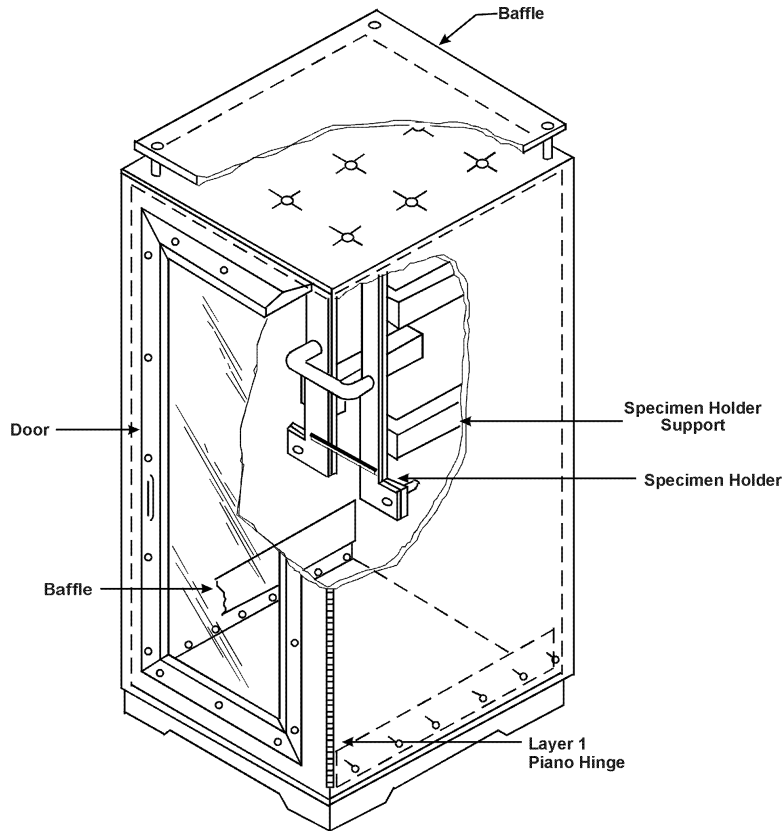

Figure 1-1. Sketch of Vertical Bunsen Burner Test Cabinet

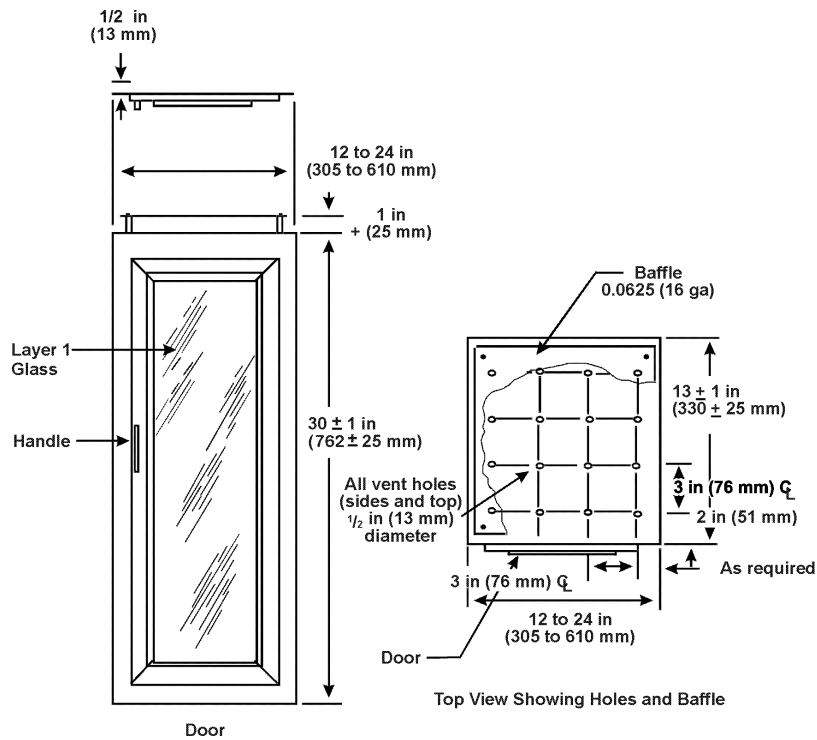

Figure 1-2. Front and Top View of Vertical Bunsen Burner Test Cabinet

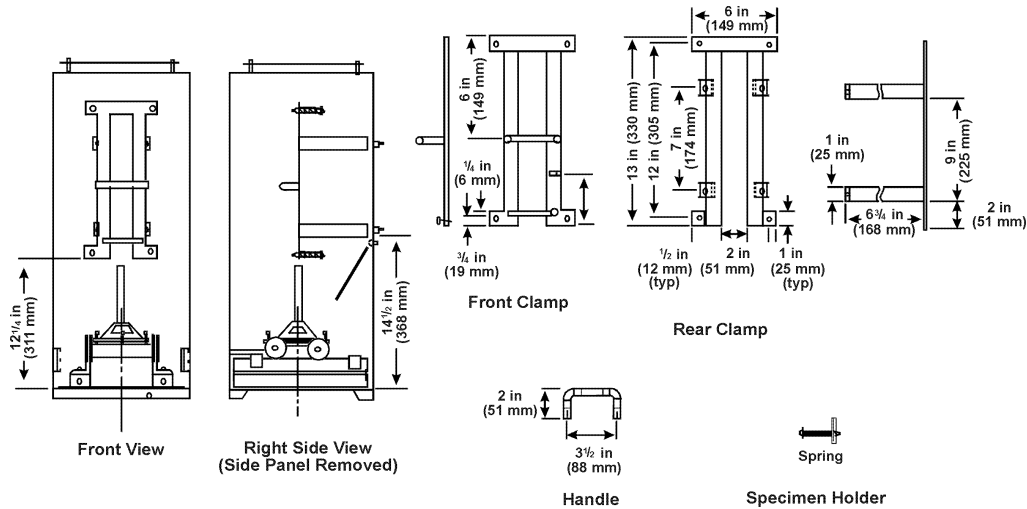

Figure 1-3. Vertical Bunsen Burner Test Specimen Holder

1.3.3 Burner

The burner will be a Bunsen or Tirrill type, have a 3/8-inch (10-mm) inside diameter barrel, and be equipped with a needle valve located at the bottom of the burner barrel to adjust the gas flow rate and, thereby, adjust the flame height. There will be a means provided to move the burner into and out of test position when the cabinet door is closed.

1.3.3.1 Burner Fuel

Methane gas (99 percent minimum purity) or other burner fuel acceptable to the FAA will be used. Methane is the preferred fuel. It can be used without adding air through the aspirating holes at the bottom of the burner barrel; e.g., a pure diffusion flame may be used.

1.3.3.2 Plumbing for Gas Supply

The necessary gas connections and the applicable plumbing will be essentially as shown in figure 1-4. A control valve system with a delivery rate designed to furnish gas to the burner under a pressure of $2 \frac{1}{2} \pm \frac{1}{4}$ psi (17 ± 2 kPa) at the burner inlet will be installed between the gas supply and the burner.

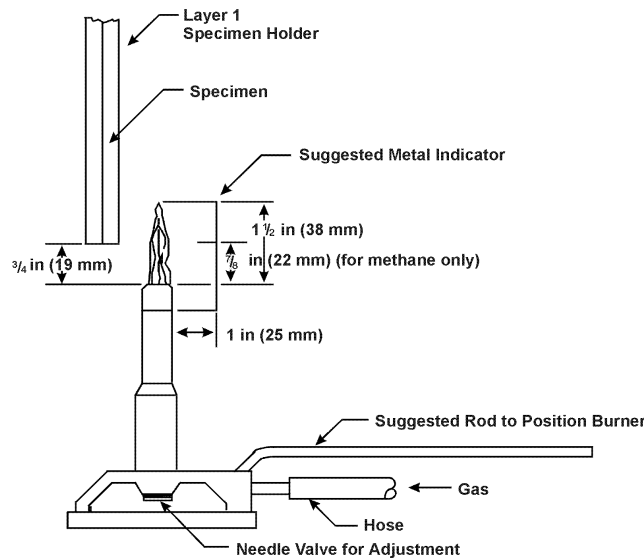

Figure 1-4. Burner Plumbing and Burner Flame Height Indicator

1.3.3.3 Flame Height Indicator

A flame height indicator may be used to aid in setting the height of the flame. A suitable indicator has a prong extending 1.5 inches (38 mm) above the top of the burner barrel, is attached to the burner barrel, and spaced 1 inch (25 mm) from the burner barrel, as shown in figure 1-4. If using methane as the burner fuel, it is desirable to have two prongs for measuring the flame height, one prong to indicate the height of the inner cone of the flame and one prong to indicate the height of the tip of the flame. For methane, it has been determined that when the height of the inner cone is 7/8 inch (22 mm) and the tip of the flame is 1.5 inches (38 mm) long, the proper flame profile is achieved.

1.3.4 Timer

A stopwatch or other device, calibrated to the nearest 0.1 second, will be used to measure the time of application of the burner flame, the flame time, and the drip flame time.

1.3.5 Ruler

A ruler or scale graduated to the nearest 0.1 inch (2.5 mm) will be provided to measure the burn length.

1.4 Test Specimens

1.4.1 Specimen Selection

Specimens tested will be either cut from a fabricated part as installed in the aircraft or cut from a section simulating a fabricated part, e.g., cut from a flat sheet of material or from a model of the fabricated part. The specimen may be cut from any location in the fabricated part. However, the edge to which the burner is applied must not consist of the finished or protected edge of the specimen. Fabricated units, such as sandwich panels, will not be separated into individual component layers for testing.

1.4.1.1 For parts that may have different flammability characteristics in different directions (e.g., textiles), separate sets of specimens, cut from each direction showing the greatest difference (e.g., warp and fill), will be provided and tested.

1.4.2 Specimen Number

Each separate set of specimens prepared for testing will consist of at least three specimens (multiple places).

1.4.3 Specimen Size

The specimen will be a rectangle at least 3 by 12 inches (75 by 305 mm), unless the actual size used in the aircraft is smaller.

1.4.4 Specimen Thickness

The specimen thickness will be the same as that of the part qualified for use in the airplane, with the following exceptions:

1.4.4.1 If the part construction is used in several thicknesses, the minimum thickness will be tested.

1.4.4.2 Foam parts that are thicker than 1/2 inch (13 mm), such as seat cushions, will be tested in 1/2-inch (13-mm) thicknesses.

1.4.4.3 Parts that are smaller than the size of a specimen and cannot have specimens cut from them may be tested using a flat sheet of the material used to fabricate the part in the actual thickness used in the aircraft.

1.5 Conditioning

Specimens will be conditioned at $70^{\circ} \pm 5^{\circ}\text{F}$ ($21^{\circ} \pm 3^{\circ}\text{C}$) and $50\% \pm 5\%$ relative humidity for 24 hours minimum. Remove only one specimen at a time from the conditioning environment immediately before testing.

1.6 Procedure

1.6.1 Burner Adjustment

- 1.6.1.1 If using methane as the burner fuel, ensure that the air supply to the burner is shut off.
- 1.6.1.2 Open the stopcock in the gas line fully and light the burner.
- 1.6.1.3 Adjust the needle valve on the burner to achieve the proper 1.5-inch (38-mm) flame height, in accordance with section 1.3.3.3.

1.6.2 Test Procedure

- 1.6.2.1 Place the burner at least 3 inches (76 mm) from where the specimen will be located during the test.
- 1.6.2.2 Insert the specimen with its lower edge 3/4 inch (19 mm) above the level of the top of the burner.
- 1.6.2.3 Close the cabinet door, and keep it closed during the test.
- 1.6.2.4 Start the timer immediately upon positioning the burner. Position the burner so that the flame impinges on the midpoint of the lower edge of the front face of the test specimen. This flame position should be used for all specimen thicknesses (see figure 1-5).

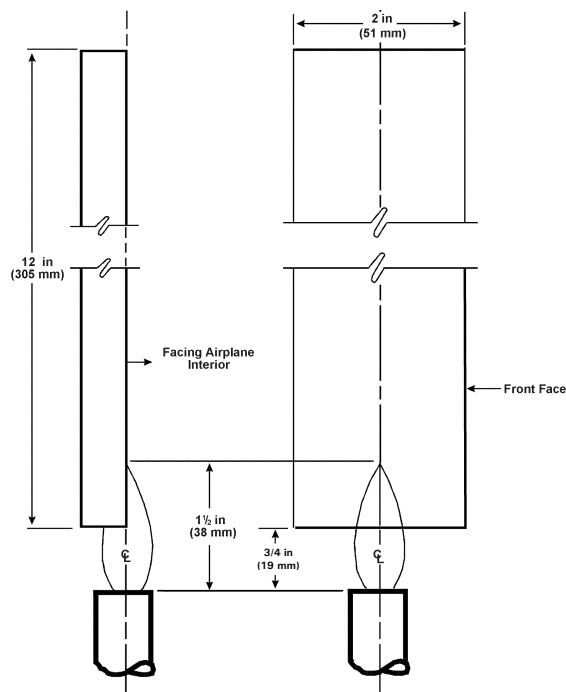

Figure 1-5. Flame Position on Vertical Specimens

- 1.6.2.5 Apply the flame for 12 seconds or 60 seconds, as appropriate, and then withdraw it by moving the burner at least 3 inches (76 mm) from the specimen or by turning the gas off.
- 1.6.2.6 If flaming material falls from the test specimen, determine the drip flame time for the specimen.
- 1.6.2.7 Determine the flame time for the specimen.

- 1.6.2.8 After all flaming ceases, open the cabinet door slowly to clear the test cabinet of fumes and smoke. The exhaust fan may be turned on to facilitate clearing smoke and fumes.
- 1.6.2.9 Remove the specimen and determine the burn length. To aid in determining the burn length, a dry soft cloth or tissue, or a soft cloth or tissue dampened with a moderate solvent, such as methyl, ethyl, or isopropyl alcohol (which does not dissolve or attack the specimen material), may be used to remove soot and stain particles from tested specimens.
- 1.6.2.10 Remove any material from the bottom of the cabinet that fell from the specimen. If necessary, clean the test cabinet window and/or back face mirror prior to testing the next specimen.

1.7 Report

1.7.1 Material Identification

Fully identify the material tested, including thickness. Also, include the specimen length if a 12-inch specimen is not available.

1.7.2 Test Results

1.7.2.1 Ignition Time

Report whether the ignition time was 12 seconds or 60 seconds.

1.7.2.2 Flame Time

Report the flame time for each specimen tested. Determine and record the average value for flame time (see section 1.2.2).

1.7.2.3 Drip Flame Time

Report the drip flame time for each specimen tested. Determine and record the average value for the drip flame time (see section 1.2.3). For specimens that have no drips, record "0" for the drip flame time and also record "No Drips."

1.7.2.4 Burn Length

Report the burn length to the nearest 0.1 inch for each specimen tested. Determine and record the average value for burn length.

1.8 Requirements

1.8.1 Flame Time

The average flame time for all of the specimens tested will not exceed 15 seconds for either the 12-second or the 60-second vertical test.

1.8.2 Drip Flame Time

The average drip extinguishing time for all of the specimens tested will not exceed 3 seconds for the 60-second vertical test or 5 seconds for the 12-second vertical test.

1.8.3 Burn Length

The average burn length for all of the specimens tested will not exceed 6 inches (152 mm) for the 60-second vertical test or 8 inches (203 mm) for the 12-second vertical test.

Chapter 1 Supplement

This supplement contains advisory material pertinent to referenced paragraphs.

1.2.1 Ignition time should start only after the flame has stabilized and is properly positioned under the test specimen.

1.2.4 This definition of burn length is a clarification of that used in FAR 25, Appendix F, Part I, viz.: “Burn length is the distance from the original edge to the farthest evidence of damage to the test specimen due to flame impingement including areas of partial or complete consumption, charring, or embrittlement, but not including areas sooted, stained, warped, or discolored nor areas where material has shrunk or melted away from the heat source.” The main point is that “damage to the test specimen due to flame impingement” is clarified by “damage to the test specimen due to that area’s combustion” because it is a better description of the intent of the rule and is consistent with current test practices.

The burn length definition specified in FAR 25, Appendix F, applies to all materials listed in Part 25.853 and FAR 25.855. Since such a wide variety of materials require vertical Bunsen burner testing, areas that might obviously be included as burn length in some materials may not always be as well defined in others.

While burn lengths of materials used in modern aircraft interiors generally fall well below the 6-inch (60-second) or 8-inch (12-second) maximum limit, it is beneficial to develop criteria for those materials that occasionally approach the pass/fail limit.

For the most part, these materials may be divided into four general categories; they are polymeric materials (such as panels, partitions, transparencies, etc., which may be hybrid or single plastic material), textiles, carpeting, and foams.

The following methods have been suggested for determining burn length:

- a. **Polymeric Materials.** In order to fix the boundary where the flame front was impinging on the specimen surface and damaging the specimen due to that area’s combustion, i.e., below which combustion of the specimen occurred and above which it did not, it is necessary to observe the specimen continuously during the test. Flame impingement on the specimen may lead to outgassing due to thermal decomposition. As these gases burn, radiating heat may cause discoloration, sooting, staining, melting, etc., to areas above the flame front. This type of damage is not a result of thermal decomposition due to flaming and, therefore, would not be included in the burn length.

- b. **Textiles.** Burn length may be determined by using weights as specified in Test Method 5903.1, “Flame Resistance of Cloth, Vertical” (12/28/87) as follows:

After removing the specimen from the test cabinet, allow the specimen to cool and then measure the burn length. The burn length is the distance from the end of the specimen, which was exposed to the flame, to the top of the lengthwise tear made through the center of the charred area. Fold the specimen lengthwise and crease it by hand along a line through the highest peak of the charred area. Insert the hook into the specimen (or insert it into a hole, 1/4 inch (6 mm) in diameter or less) at one side of the charred area 1/4 inch (6 mm) in from the lower end. Attach a weight to the hook of sufficient size (that the weight and hook together equal the total tearing load required shown in table 1).

Gently apply a tearing force to the specimen by grasping the corner of the cloth at the opposite edge of the char from the load and raising the specimen and weight clear of the supporting surface. Raise the specimen in one smooth continuous motion; do not jerk or pull the specimen forcefully upward. Mark the end of the tear on the edge of the specimen and take the char length measurement along the undamaged edge.

- c. **Carpeting.** Tear the specimen with your hands. Use only enough force to tear the charred material. Stop when the fabric does not give way freely.

- d. Polyurethane Foams. Polyurethane foams are cellular in nature and, therefore, have low thermal conductivity. Since high surface temperatures are generated on exposure to the burner flame, an almost instantaneous conversion to flammable gases results. This, in turn, produces rapid surface flame spread with complete consumption of the foam immediately above the ignition source. By definition, complete consumption of an area is part of the burn length and should be included.

Table 1-1. Loads for Determining Char Length

The specific load applicable to the weight of the test cloth should be as follows:			
Specified weight per square yard of cloth before any fire retardant treatment or coating		The tearing weight for determining the charred length	
Ounces per square yard	g/m²	Pounds	kg
2.0 to 6.0	68 to 203	0.25	0.1
Over 6.0 to 15.0	Over 203 to 508	0.5	0.2
Over 15.0 to 23.0	Over 508 to 780	0.75	0.3
Over 23.0	Over 780	1.0	0.45

1.3.1 Suitable test cabinets of the type described are manufactured by the U.S. Testing Co., 1415 Park Ave., Hoboken, New Jersey 07030; Atlas Electric Devices Co., 4114 N. Ravenswood Ave., Chicago, Illinois 60613; and The Govmark Organization, Inc., P.O. Box 807, Bellmore, New York 11710.

Draft free implies a condition of no air currents in a closed in space. One way of determining whether the cabinet is draft free is to place a smoldering and smoking material, such as a lighted cigarette, in the test cabinet, then closing the door and observing the behavior of the smoke for signs of drafts. A test cabinet other than one fabricated in accordance with figures 1-1 to 1-3 may be found to be acceptable after review by the FAA.

The entire inside back wall of the chamber may be painted flat black to facilitate viewing of the test specimen, and a mirror may be located on the inside back surface to facilitate observation of the hidden surfaces.

1.3.3 A suitable burner is available from Rascher & Betzold Inc., 5410 N. Damen Ave., Chicago, Illinois 60625, Catalog No. R3726A.

1.3.3.1 Gases such as natural gas and propane can be used as burner fuel. However, it should be required to show compliance with the 1550°F minimum flame temperature using a 24 American Wire Gauge (AWG) thermocouple.

B-gas, which is the burner fuel specified in Federal Test Method Standard 5903, meets minimum temperature requirements and is still used in some laboratories. However, its use has resulted in problems and is not recommended. See note below for more details.

NOTE: B-gas, a mixture of 55 percent hydrogen, 18 percent carbon monoxide, 24 percent methane, and 3 percent ethane, has shown inconsistent burning characteristics in steel cylinders. A “spike” of varying intensity is produced. It has been postulated that the carbon monoxide in the gas may react with the iron in the steel cylinders to produce iron pentacarbonyl (Fe(CO)₅), which is volatile and may cause interference with the normal flame characteristics and may be the cause of the erratic behavior. Because of the inconsistent flame characteristics, B-gas, at least if supplied in steel cylinders, is not recommended. No data are presently available about the suitability of B-gas supplied in cylinders of other materials, such as aluminum.

A phenomenon that some labs have experienced is a sharp decrease in flame temperature after about three-fourths of the gas originally in the cylinder has been used. This has occurred primarily in labs that have single-stage regulators on their gas cylinders. Single-stage regulators differ from two-stage regulators in that control of the discharge pressure is not as accurate. Few designs should maintain constant or near constant discharge pressures over the full range of cylinder pressures. Therefore, it is necessary to make adjustments periodically to allow for decreasing inlet pressures. Even the slightest drop in pressure should affect the flow rate of gas through the burner orifice. This, in

turn, should cause temperature variation. By using a two-stage regulator or adjusting pressure on a single-stage regulator, as the cylinder gets low, this problem can essentially be eliminated.

1.3.3.3 The tip of the methane flame is blue, transparent, and difficult to see. It is more easily seen if there is no light on the flame, as in a darkened room. The inner cone of the flame is, however, more visible and easily seen and can be used to monitor flame height. When the flame height (blue transparent tip) is set to 1.5 inches, the height of the inner cone has been found to vary slightly from burner to burner, but is generally about 7/8 inch. Therefore, if the inner cone height is used to monitor flame height, the inner cone height needs to be established for that burner.

1.4.1 Currently, the most commonly used specimens are thermal/acoustic insulation blankets consisting of fiberglass insulation with scrimmed film cover. Appendix F to FAR Part 25 states that materials must be tested either as a section cut from a fabricated part as installed in the airplane or as a specimen simulating a cut section. Therefore, it is by regulation mandated that the insulation blanket be tested as a finished product (insulation and film cover together). Appendix F also states that the edge to which the burner flame is applied must not consist of the finished or protected edge of the specimen, but must be representative of the actual cross-section of the material or part installed in the airplane. Therefore, a 3- by 12-inch section of the blanket for vertical testing should be cut from the interior and must not include an enclosed edge.

1.4.3 By regulation, there must be at least 2 inches of the specimen exposed; however, the text specifies a specimen cut 3 inches in width. This allows enough material to ensure that the specimen is securely held in the holder. From experience, it has been found that materials such as textiles and films are difficult to secure in the holder and, therefore, may be cut even greater than 3 inches in width. This allows the operator adequate material to pull or adjust so that the specimen does not buckle or fall out of the holder.

1.4.4 According to the FAR 25.853, the specimen thickness must be no thicker than the minimum thickness to be qualified for use in the airplane. If the test facility has found from experience or has questions concerning the flammability of a thicker specimen, then vertical testing may be conducted and test data recorded for further review.

1.5 As stated in the FAR 25.853, only one specimen may be removed at a time from the conditioning chamber prior to being subjected to the flame. Some facilities, however, have conditioning chambers located in areas remote from the testing area. In this case, it is permissible to remove more than one specimen at a time only if each specimen is placed in a closed container (a plastic stowage bag is acceptable) and protected from contamination such as dirty lab tops, soot in the air, etc., until the specimen is subjected to the flame.

1.6.2.2 Inserting the standard sized 3-inch (76-mm) -thick thermal/acoustic insulation test specimen into the Bunsen burner holder results in extreme compression of the blanket on the sides and an elliptical section on the bottom center. This configuration may compromise test results. The recommended method is to mount the specimen on the front face of the holder and use safety wire to secure it in place. It has been found that two pieces of safety wire, one wrapped around the 10-inch point and one wrapped around the 6-inch point, keep the sample flat and in place.

1.6.2.3 It is important to note that the test should be watched carefully while it is being conducted. This applies to all samples.

1.6.2.4 More information is available in DOT/FAA/CT-86/22, "An Investigation of the FAA Vertical Bunsen Burner Flammability Test Method." Appendix F, FAR 25.853, Part I describes this test and specifies that the flame be placed "along the centerline of the lower edge." The "centerline of the lower edge" is the line from the front face to the back face of the specimen. For thicker specimens, this is ambiguous since exactly "where" along the "centerline of the lower edge" is not specified.

Historically, test practices regarding burner flame placement have not been uniform or consistent within either the FAA or aircraft manufacturers. The most common placement used in the past was specified in the original issue of this handbook, viz.:

For specimens that are 3/4 inch (19 mm) thick or less, place the burner barrel centerline under the center of the bottom surface of the specimen.

For specimens thicker than 3/4 inch (19 mm), center the burner barrel under the bottom surface of the specimen 3/8 inch (10 mm) in from the surface exposed to the airplane interior, test each surface separately unless the surfaces are of the same materials and construction.

Another placement that has been less commonly used is that specified here, viz., directly under the middle of the lower edge of the face of the specimen that is exposed to the airplane interior. For specimens thinner than the burner barrel thickness (3/8 inch; 10 mm), test results are relatively insensitive to exactly where “along the centerline of the lower edge” the burner flame is placed. For samples of greater thickness, however, burn lengths are typically an inch or so longer if the burner barrel centerline is placed under or near the specimen face, and flame times are sometimes a little longer than if the flame is placed per the original handbook, Report DOT/FAA/CT-89/15, September 1990.

Materials used in contemporary (especially postheat release) designs produce burn lengths and flame times that are considerably less than the acceptance criteria for certification (6 inches and 15 seconds), regardless of where the flame is placed. Although where the burner flame is applied is not of important pass/fail significance in this test, placing it directly under the specimen face generally represents a worst-case situation.

The FAA should accept data for certification using the flame placement described in the original portion of this handbook, or using the flame placed under the exposed face of the test specimen. However, the FAA and aircraft manufacturers have agreed that in the future, the preferred placement of the burner flame is under the middle of the lower edge of the face of the specimen.

1.6.2.5 If the burner extinguishes during the ignition time for any reason, rerun the test. From experience, it has been found that this is a necessary requirement when running a 12-second test. However, experience has also shown that if the flame extinguishes during a 60-second test, the test is not compromised by relighting the flame up to three times and adding up the ignition times. If the flame does extinguish, the flame must be relighted immediately. Failure to do so could result in the specimen cooling and compromising test results. The opposite end of the same specimen can be used for the retest if the burn length for the aborted test is less than 3 inches (76 mm). If the burn length for the aborted test is greater than 3 inches (76 mm), a new specimen must be used.

1.6.2.8 The operator should refer to the facility’s safety manual for further information on dealing with smoke and flammability by-products.

Chapter 2

45-Degree Bunsen Burner Test for Cargo Compartment Liners and Waste Stowage Compartment Materials

2.1 Scope

This test method is intended for use in determining the resistance of materials to flame penetration and to flame and glow propagation when tested according to the 30-second, 45-degree Bunsen burner test specified in FAR 25.

2.2 Definitions

2.2.1 Ignition Time

Ignition time is the length of time the burner flame is applied to the specimen. For this test, the ignition time is 30 seconds.

2.2.2 Flame Time

Flame time is the time in seconds that the specimen continues to flame after the burner flame is removed from under the specimen.

2.2.3 Glow Time

Glow time is the length of time in seconds that the specimen continues to glow after any flaming combustion ceases following the removal of the ignition flame.

2.2.4 Flame Penetration

Flame penetration occurs if the Bunsen burner flame penetrates (passes through) the test specimen through a hole or crack in the specimen that forms during the test ignition time. Flaming combustion on the top of the specimen that results from auto ignition is not considered flame penetration in this test.

2.3 Test Apparatus

2.3.1 Test Cabinet

Tests will be conducted in a draft-free cabinet as shown in figures 2-1 to 2-3 or other equivalent enclosures acceptable to the FAA. It is suggested that the cabinet be located inside an exhaust hood to facilitate clearing the cabinet of smoke after each test. Stainless steel or other corrosion resistant metal, 0.04 inch (1 mm) thick, will be used for the bottom surface of the chamber.

2.3.2 Specimen Holder

The specimen holder will be fabricated of corrosion-resistant metal and will be capable of securely positioning the specimen at a 45-degree angle, with the vertical as shown in figure 2-4. The holder will be able to accommodate specimens up to 1 inch (25 mm) thick.

2.3.3 Burner

The burner will be a Bunsen or Tirrill type, have a 3/8-inch (10-mm) inside diameter barrel, and will be equipped with a needle valve located at the bottom of the burner barrel to adjust the gas flow rate and, thereby, adjust the flame height (see figure 2-5). There will be a means provided to move the burner into and out of test position when the cabinet door is closed.

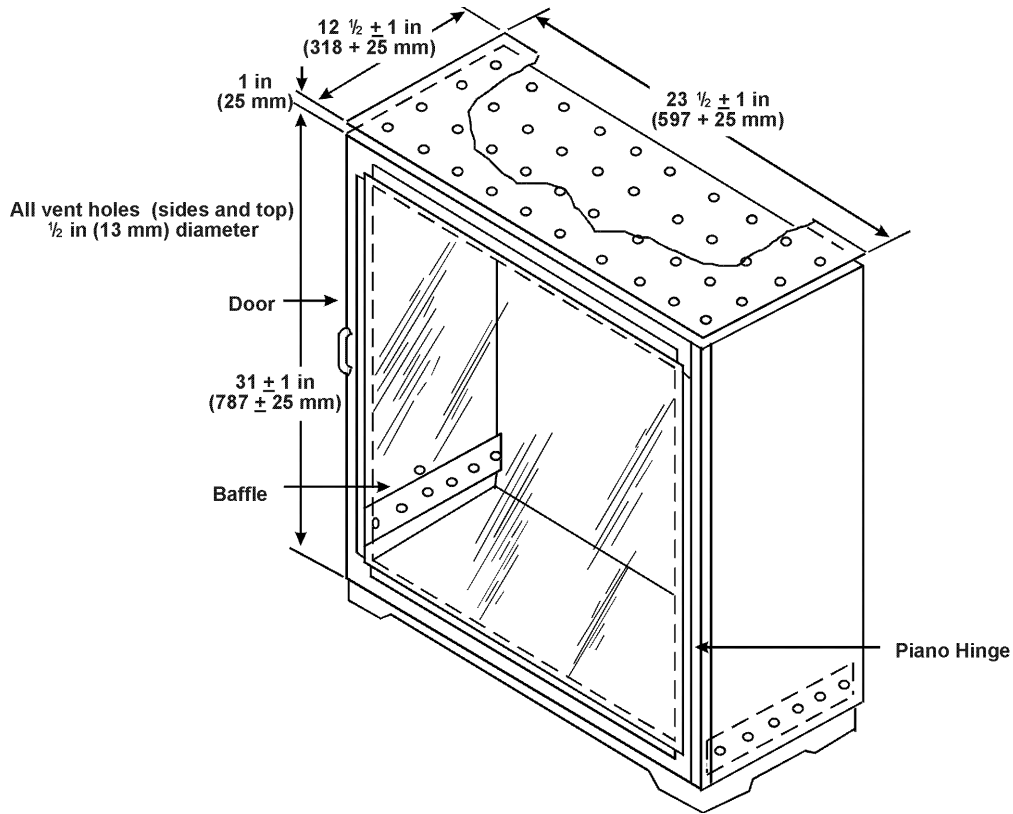

Figure 2-1. Sketch of 30-Second, 45-Degree Bunsen Burner Test Cabinet

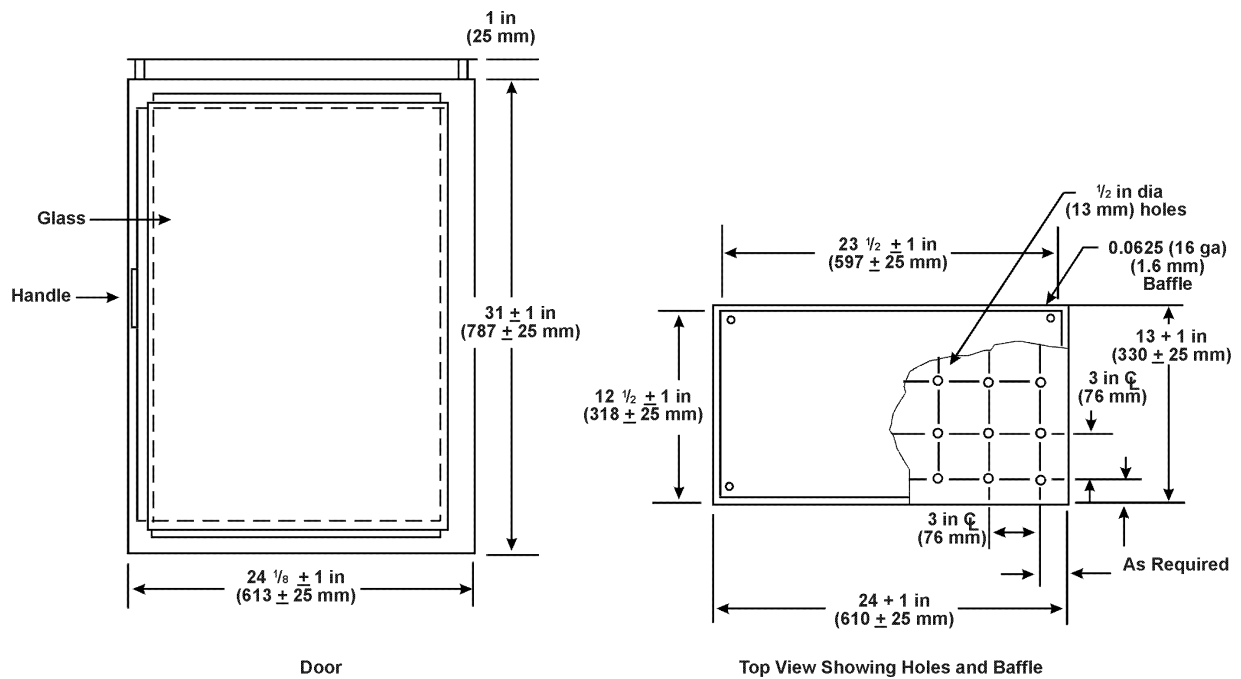

Figure 2-2. Front and Top View of 30-Second, 45-Degree Bunsen Burner Test Cabinet

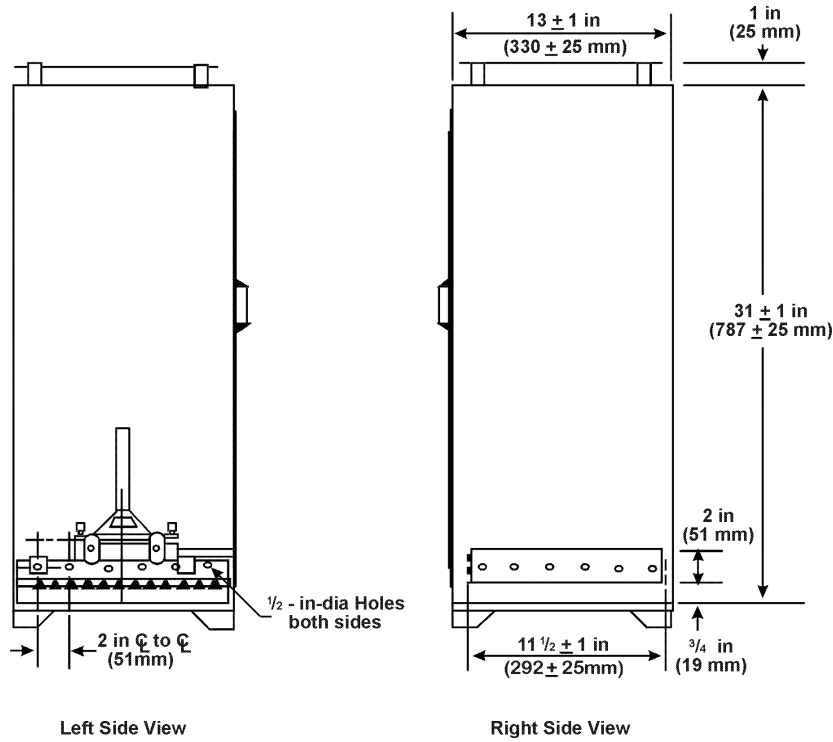

Figure 2-3. Side Views of 30-Second, 45-Degree Bunsen Burner Test Cabinet

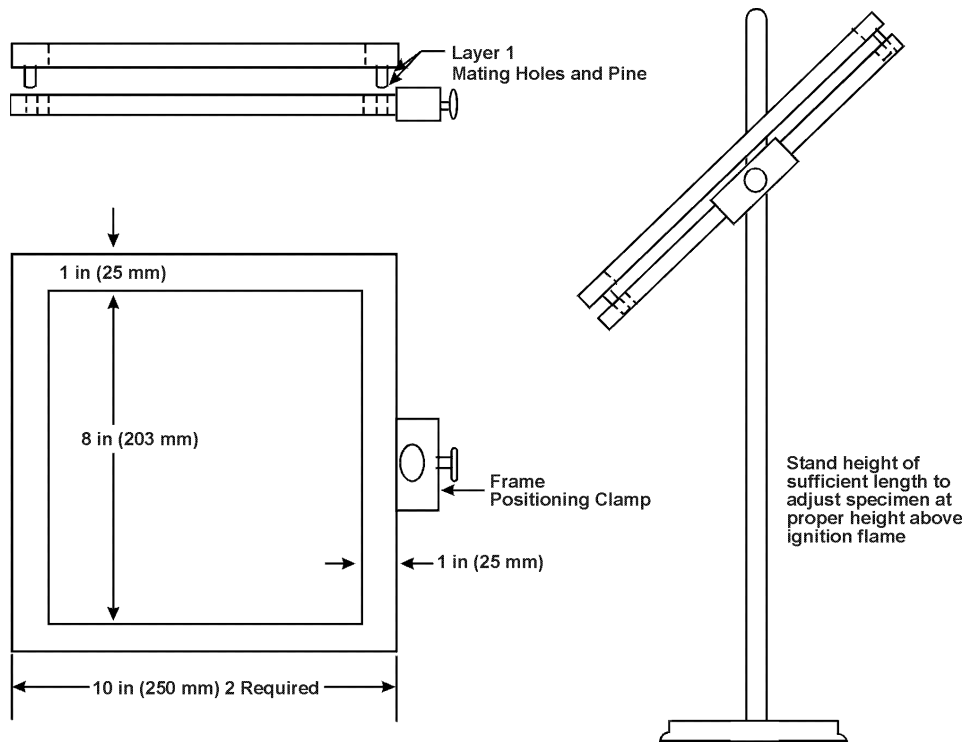

Figure 2-4. 30-Second, 45-Degree Bunsen Burner Test Specimen Frame and Stand

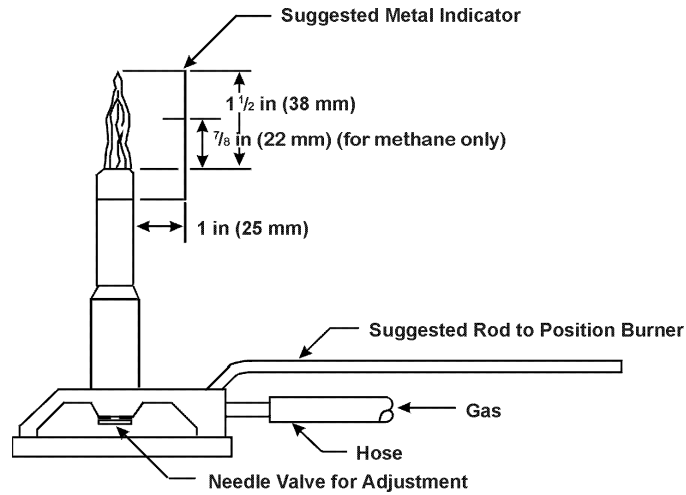

Figure 2-5. Burner Plumbing and Burner Flame Height Indicator

2.3.3.1 Burner Fuel

Methane gas (99 percent minimum purity) or other burner fuel acceptable to the FAA will be used. Methane is the preferred fuel. It can be used without adding air through the aspirating holes at the bottom of the burner barrel, i.e., a pure diffusion flame may be used.

2.3.3.2 Plumbing for Gas Supply

The necessary gas connections and the applicable plumbing will be essentially as shown in figure 2-5. A control valve system with a delivery rate designed to furnish gas to the burner inlet under a pressure of $2 \frac{1}{2} \pm \frac{1}{4}$ psi (17 ± 2 kPa) at the burner inlet will be installed between the gas supply and the burner.

2.3.3.3 Flame Height Indicator

A flame height indicator may be used to aid in setting the height of the flame. A suitable indicator has a prong extending 1.5 inches (38 mm) above the top of the burner barrel, is attached to the burner barrel, and spaced 1 inch (25 mm) away from the burner barrel, as shown in figure 1-4. If using methane as the burner fuel, it is desirable to have two prongs for measuring the flame height, one prong to indicate the height of the inner cone of the flame and one prong to indicate the height of the tip of the flame. For methane, it has been determined that when the height of the inner cone is $\frac{7}{8}$ inch (22 mm) and the tip of the flame is 1.5 inches (38 mm) long the proper flame profile is achieved.

2.3.3.4 Burner Positioning

There will be means provided to position the burner directly below the center of the specimen and also to move it at least 3 inches (76 mm) from the specimen.

2.3.4 Timer

A stopwatch or other device, calibrated to the nearest 0.1 second, will be used to measure the time of application of the burner flame, the flame time, and the glow time.

2.4 Test Specimens

2.4.1 Specimen Selection

Specimens tested will be either cut from a fabricated part as installed in the aircraft or cut from a section simulating a fabricated part, e.g., cut from a flat sheet of material or from a model of the fabricated part.

The specimen may be cut from any location in the fabricated part. Fabricated units, such as sandwich panels, will not be separated into individual component layers for testing.

2.4.2 Specimen Number

Each separate set of specimens prepared for testing will consist of at least three specimens (multiple places).

2.4.3 Specimen Size

The specimen will be a square large enough to allow an exposed area of 8 inches (203 mm) by 8 inches (203 mm). A nominal specimen size of 10 inches (254 mm) by 10 inches (254 mm) has been found satisfactory; however, actual specimen size is dependent upon the details of the specimen holder selected for the test equipment.

2.4.4 Specimen Thickness

The specimen thickness will be the same as that of the part to be qualified for use in the aircraft, with the following exceptions:

2.4.4.1 If the part construction is used in several thicknesses, the minimum thickness will be tested.

2.4.4.2 Parts that are smaller than the size of a specimen and cannot have specimens cut from them will be tested using a flat sheet of the material used to fabricate the part in the actual thickness used in the airplane.

2.5 Conditioning

Condition specimens at $70 \pm 5^\circ\text{F}$ ($21 \pm 3^\circ\text{C}$) and $50\% \pm 5\%$ relative humidity for 24 hours minimum. Remove only one specimen at a time from the conditioning environment immediately before testing.

2.6 Procedure

2.6.1 Burner Adjustment

2.6.1.1 If using methane as the burner fuel, ensure that the air supply to the burner is shut off.

2.6.1.2 Open the stopcock in the gas line fully and light the burner.

2.6.1.3 Adjust the needle valve on the burner to achieve the proper 1.5-inch (38-mm) flame height in accordance with section 2.3.3.3.

2.6.2 Test Procedure

2.6.2.1 Place the burner at least 3 inches (76 mm) from where the edge of the specimen will be located during the test.

2.6.2.2 Place the specimen in the holder with the surface to be exposed when installed in the aircraft toward the flame. The specimen will be positioned so that one-third of the height of the flame is in contact with the material when the test is in progress.

2.6.2.3 Close the cabinet door, and keep it closed during the test.

2.6.2.4 The timer must be started immediately upon positioning the burner. Position the burner so that the center of the burner barrel is under the center of the bottom surface of the specimen, as shown in figure 2-6.

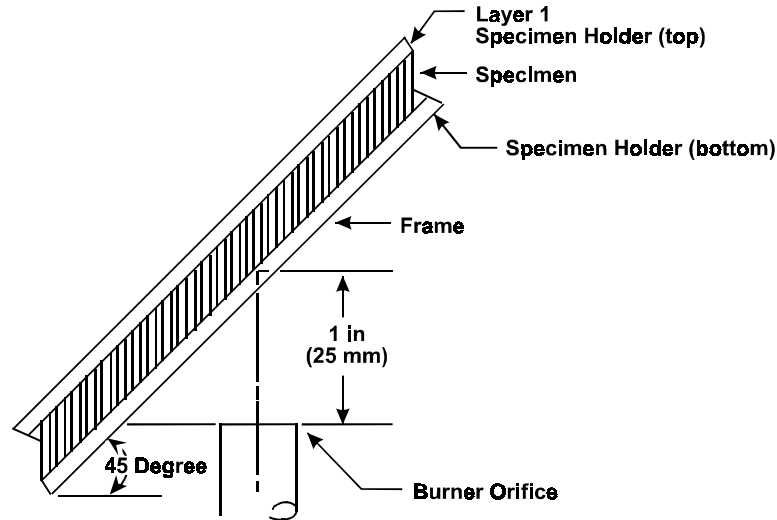

Figure 2-6. Flame Position on 30-Second, 45-Degree Bunsen Burner Test Specimen

- 2.6.2.5 Apply the flame for 30 seconds and then withdraw it by moving the burner at least 3 inches away from the specimen or by turning the gas off.
- 2.6.2.6 Determine the flame time for the specimen.
- 2.6.2.7 Determine the glow time for the specimen.
- 2.6.2.8 Determine if flame penetration occurs.
- 2.6.2.9 After all flaming ceases, open the cabinet door slowly to clear the test cabinet of fumes and smoke. The exhaust fan may be turned on to facilitate clearing of smoke and fumes. Remove any material from the bottom of the cabinet that fell from the specimen.
- 2.6.2.10 If necessary, clean the test cabinet window prior to testing the next specimen.

2.7 Report

2.7.1 Material Identification

Fully identify the material tested, including thickness.

2.7.2 Flame Time

Report the flame time for each specimen to the nearest 0.2 second. Determine and record the average flame time for all specimens tested.

2.7.3 Glow Time

Report the glow time for each specimen tested to the nearest second. Determine and record the average glow time for all specimens tested.

2.7.4 Flame Penetration

Report whether the Bunsen burner flame penetrated the specimen for each specimen tested.

2.8 Requirements

2.8.1 Flame Time

The average flame time for all specimens tested will not exceed 15 seconds.

2.8.2 Flame Penetration

The Bunsen burner flame will not penetrate any of the specimens tested.

2.8.3 Glow Time

The average glow time for all specimens tested will not exceed 10 seconds.

Chapter 2 Supplement

This supplement contains advisory material pertinent to referenced paragraphs.

2.2.1 Ignition time should start only after the flame has stabilized and is properly positioned under the test specimen.

2.3.1 Suitable test cabinets of the type described are manufactured by the U.S. Testing Co., 1415 Park Ave., Hoboken, New Jersey 07030; Atlas Electric Devices Co., 4114 N. Ravenswood Ave., Chicago, Illinois 60613; and The Govmark Organization Inc., P.O. Box 807, Bellmore, New York 11710.

Draft free means a condition of no air currents in a closed in space for this test cabinet. One way of determining whether the cabinet is draft free is to place a smoldering and smoking material, such as a lighted cigarette, in the test cabinet, then closing the door and observing the behavior of the smoke for signs of drafts. A test cabinet other than one fabricated in accordance with figures 2-1 to 2-3 may be found to be acceptable after review by the FAA.

The entire inside back wall of the chamber may be painted flat black to facilitate viewing of the test specimen, and a mirror may be located on the inside back surface to facilitate observation of the hidden surfaces of the specimen.

2.3.3 A burner available as catalog number R3726A from Rascher & Betzold, Inc., 5410 N. Damen Ave., Chicago, Illinois 60625, has been found suitable.

2.3.3.1 Gases such as natural gas and propane can be used as burner fuel. However, it should be required to show compliance with the 1550°F minimum flame temperature using a 24 AWG thermocouple.

B-gas, which is the burner fuel specified in Federal Test Method 5903, meets minimum temperature requirements and is still used in some laboratories. However, its use has resulted in problems and is not recommended. See note below for more details.

NOTE: B-gas, a mixture of 55 percent hydrogen, 18 percent carbon monoxide, 24 percent methane, and 3 percent ethane, has shown inconsistent burning characteristics in steel cylinders. A “spike” of varying intensity is produced. It has been postulated that the carbon monoxide in the gas may react with the iron in the steel cylinders to produce iron pentacarbonyl ($\text{Fe}(\text{CO})_5$), which is volatile and may cause interference with the normal flame characteristics and may be the cause of the erratic behavior. Because of the inconsistent flame characteristics, B-gas, at least if supplied in steel cylinders, is not recommended. No data are presently available about the suitability of B-gas supplied in cylinders of other materials, such as aluminum.

One noteworthy point that should be mentioned is the phenomenon that some labs have experienced sharp decreases in flame temperature after the gas cylinders are approximately three-fourths empty. This has occurred primarily in labs that have single-stage regulators on their gas cylinders. Single-stage regulators differ from two-stage regulators in that control of the discharge pressure is not as accurate. Few designs maintain constant or near constant discharge pressures over the full range of cylinder pressures. Therefore, it is necessary to make adjustments periodically to allow for decreasing inlet pressures. Even the slightest drop in pressure should affect the flow rate of gas through the burner orifice. This, in turn, should cause temperature variation. By using a two-stage regulator or adjusting pressure on a single-stage regulator, as the cylinder gets low, this problem can be eliminated.

2.3.3.3 The tip of the methane flame is blue, transparent, and difficult to see. It is more easily seen if there is no light on the flame, as in a darkened room. The inner cone of the flame is, however, more visible and easily seen.

2.4.4 According to the FAR 25.853, the specimen thickness must be no thicker than the minimum thickness to be qualified for use in the airplane. If the test facility has found from experience or has questions concerning the flammability of a thicker specimen, then vertical testing may be conducted and test data recorded for further review.

2.5 As stated in the FAR 25.853, only one specimen may be removed at a time from the conditioning chamber prior to being subjected to the flame. Some facilities, however, have conditioning chambers located in areas remote

from the testing area. In this case, it is permissible to remove more than one specimen at a time only if each specimen is placed in a closed container (a plastic stowage bag is acceptable) and protected from contamination such as dirty lab tops, soot in the air, etc., until the specimen is subjected to the flame.

2.6.2.3 It is important to note that the test should be watched carefully while it is being conducted. This applies to all samples.

2.6.2.5 Some laboratories turn the gas off upon completion of the test; however, the majority of test facilities, including the Original Equipment Manufacturers (OEMs), withdraw the flame by moving the burner away from the specimen.

2.6.2.9 The operator should refer to the facility's safety manual for further information dealing with smoke and flammability by-products.

Chapter 3

Horizontal Bunsen Burner Test for Cabin, Cargo Compartment, and Miscellaneous Materials

3.1 Scope

This test method is intended for use in determining the resistance of materials to flame when tested according to the 15-second horizontal Bunsen burner tests specified in FAR 25.853.

3.2 Definitions

3.2.1 Ignition Time

Ignition time is the length of time the burner flame is applied to the specimen. For this test, the ignition time is 15 seconds.

3.2.2 Burn Rate

Burn rate is the rate at which a flame front moves over a specified distance on a test specimen, under specified test conditions. In this test, it is the rate with which a flame front moves across a test specimen mounted horizontally.

3.3 Apparatus

3.3.1 Test Cabinet

Tests will be conducted in a draft-free cabinet fabricated in accordance with figures 3-1 to 3-3 or other equivalent enclosures acceptable to the FAA. It is suggested that the cabinet be located inside an exhaust hood to facilitate clearing the cabinet of smoke after each test. Stainless steel or other corrosion resistant metal, 0.04 inch (1 mm) thick will be used for the bottom surface of the chamber.

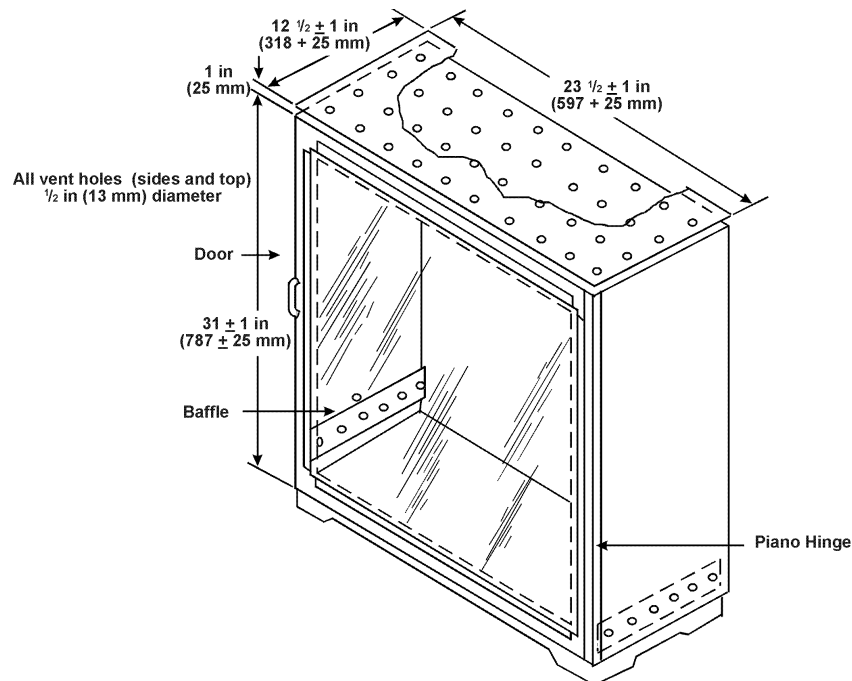

Figure 3-1. Sketch of Horizontal Bunsen Burner Test Cabinet

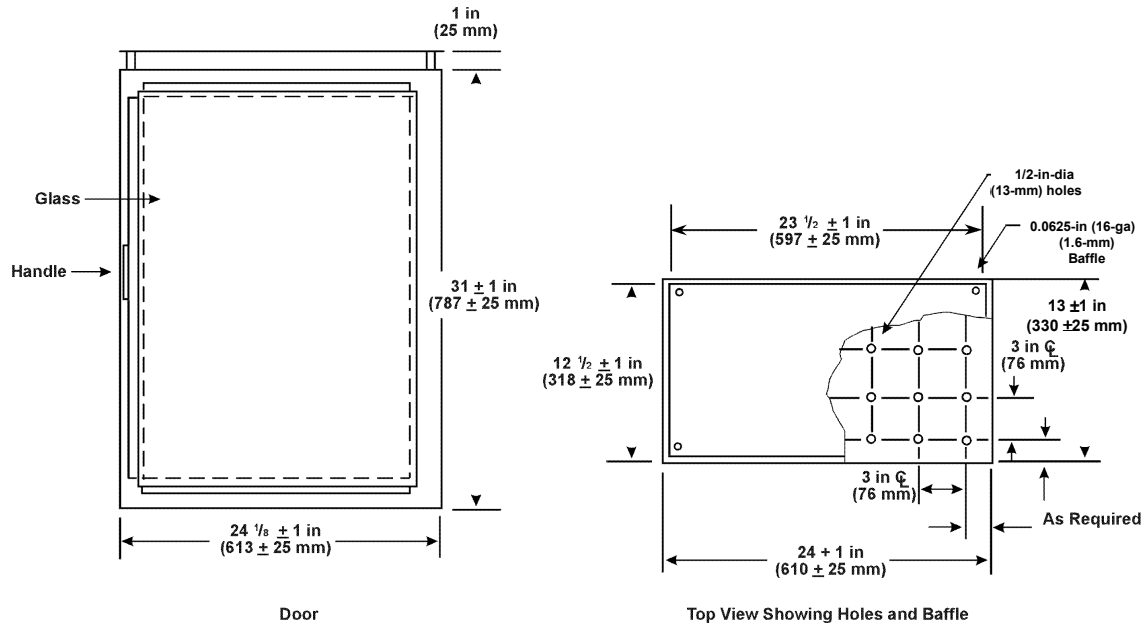

Figure 3-2. Front and Top View of Horizontal Bunsen Burner Test Cabinet

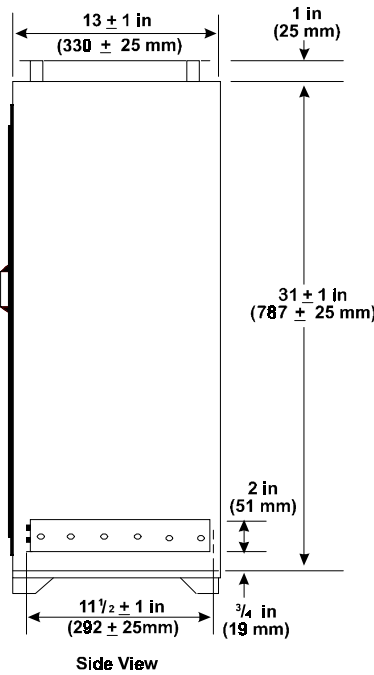

Figure 3-3. Side View of Horizontal Bunsen Burner Test Cabinet

3.3.2 Specimen Holder

A specimen holder fabricated of corrosion-resistant metal in accordance with figure 3-4 will be used. When performing the tests, the specimen will be mounted in the frame so that the two long edges are held securely. The exposed area of the specimen will be 2 inches (51 mm) in width and 12 inches (305 mm) in length.

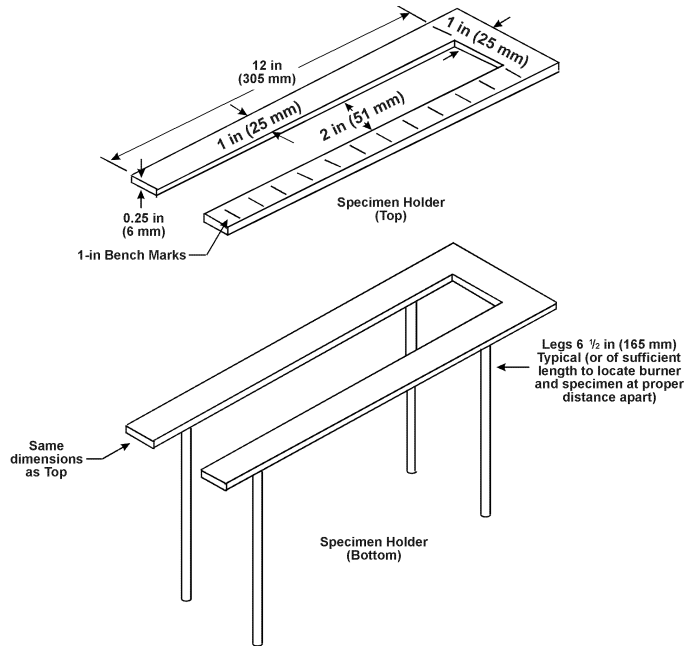

Figure 3-4. Horizontal Bunsen Burner Test Specimen Holder

3.3.3 Burner

The burner will be a Bunsen or Tirrill type, have a 3/8-inch (10-mm) inside diameter barrel, and will be equipped with a needle valve located at the bottom of the burner barrel to adjust the gas flow rate and, thereby, adjust the flame height. There will be a means provided to move the burner into and out of test position when the cabinet door is closed.

3.3.3.1 Burner Fuel

Methane gas (99 percent minimum purity) or other burner fuel acceptable to the FAA will be used. Methane is the preferred fuel. It can be used without adding air through the aspirating holes at the bottom of the burner barrel, i.e., a pure diffusion flame may be used.

3.3.3.2 Plumbing for Gas Supply

The necessary gas connections and the applicable plumbing will be essentially as shown in figure 3-5. A control valve system with a delivery rate designed to furnish gas to the burner under a pressure of $2 \frac{1}{2} \pm \frac{1}{4}$ psi (17 ± 2 kPa) at the burner inlet will be installed between the gas supply and the burner.

3.3.3.3 Flame Height Indicator

A flame height indicator may be used to aid in setting the height of the flame. A suitable indicator has a prong extending 1.5 inches (38 mm) above the top of the burner barrel, is attached to the burner barrel, and spaced 1 inch (25 mm) from the burner barrel, as shown in figure 3-5. If using methane as the burner fuel, it is desirable to have two prongs for measuring the flame height, one prong to indicate the height of the inner cone of the flame and one prong to indicate the height of the tip of the flame. For methane, it has been determined that when the height of the inner cone is 7/8 inch (22 mm) and the tip of the flame is 1.5 inches (38 mm) long, the proper flame profile is achieved.

3.3.4 Timer

A stopwatch or other device, calibrated to the nearest 0.1 second, will be used to measure the time of application of the burner flame, the flame time, and the drip flame time.

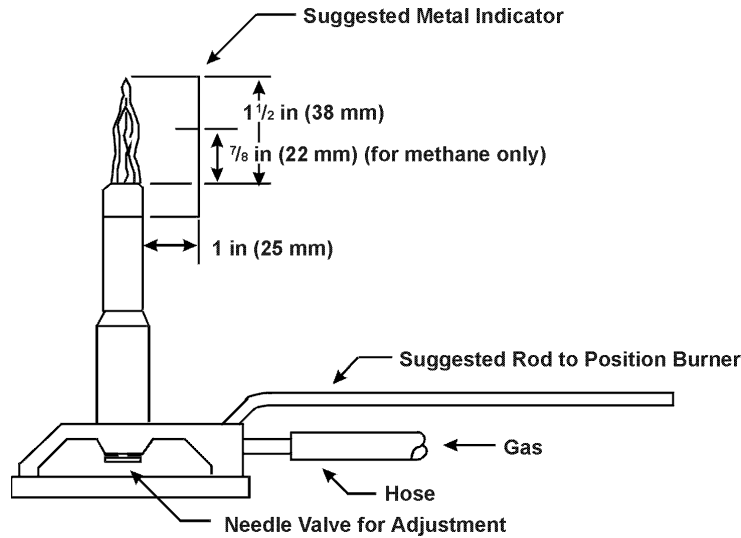

Figure 3-5. Burner Plumbing and Burner Flame Height Indicator

3.3.5 Ruler

A ruler or scale graduated to the nearest 0.1 inch (2.5 mm) will be provided to measure gage marks and flame front position.

3.4 Test Specimens

3.4.1 Specimen Selection

Specimens tested will be either cut from a fabricated part as installed in the aircraft or cut from a section simulating a fabricated part, e.g., cut from a flat sheet of material or from a model of the fabricated part. The specimen may be cut from any location in the fabricated part. Fabricated units, such as sandwich panels, will not be separated into individual component layers for testing.

3.4.2 Specimen Number

Each separate set of specimens prepared for testing will consist of at least three specimens (multiple places).

3.4.3 Specimen Size

The specimen will be a rectangle at least 3 by 12 inches (76 by 305 mm), unless the actual size used in the aircraft is smaller.

3.4.4 Specimen Thickness

The specimen thickness will be the same as that of the part qualified for use in the aircraft, with the following exceptions:

- 3.4.4.1 The specimen thickness must be no thicker than the minimum thickness to be qualified for use in the aircraft. The specimen thickness will not exceed 1/8 inch (3 mm).
- 3.4.4.2 Parts that are smaller than the size of a specimen and cannot have specimens cut from them may be tested using a flat sheet of the material used to fabricate the part in the actual thickness used in the aircraft. The sheet thickness will not exceed 1/8 inch (3 mm) if the test being run is the 4 inches per minute horizontal burn rate test.

3.4.5 Specimen Preparation

Mark gauge lines on the back surface (opposite the surface to be exposed to the flame) of the specimen 1.5 inches (38 mm) and 11.5 inches (292 mm) from the end of the specimen that will be subjected to the flame.

- 3.4.5.1 A fine-gauge wire mesh with large openings can be used to support test specimens that sag severely during testing so that the flame propagation may be determined accurately.

3.5 Conditioning

Condition specimens at $70 \pm 5^\circ\text{F}$ ($21 \pm 3^\circ\text{C}$) and $50\% \pm 5\%$ relative humidity for 24 hours minimum. Remove only one specimen at a time from the conditioning environment immediately before being tested.

3.6 Procedure

3.6.1 Burner Adjustment

- 3.6.1.1 If using methane as the burner fuel, ensure that the air supply to the burner is shut off.
- 3.6.1.2 Open the stopcock in the gas line fully and light the burner.
- 3.6.1.3 Adjust the needle valve on the burner to achieve the proper 1.5-inch (38-mm) flame height in accordance with section 3.3.3.3.

3.6.2 Test Procedure

- 3.6.2.1 Place the burner at least 3 inches (76 mm) from where the specimen will be located during the test.
- 3.6.2.2 Insert the specimen face down (the exposed surface when installed in the aircraft) into the specimen holder so that the end of the specimen from which the 1.5-inch (38-mm) gauge mark was measured is flush with the open end of the specimen holder (see figure 3-6).

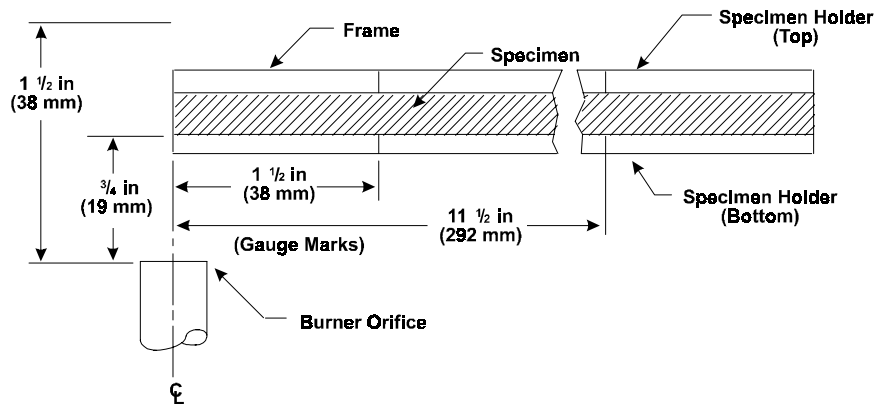

Figure 3-6. Typical Burner and Specimen Location

- 3.6.2.3 Close the cabinet door, and keep it closed during the test.
- 3.6.2.4 Start the timer immediately upon positioning the burner. Position the burner so that the centerline of the burner orifice is in line with the edge of the specimen holder and the centerline of the width of the specimen (see figure 3-6).
- 3.6.2.5 Apply the flame for 15 seconds and then withdraw it by moving the burner at least 3 inches (76 mm) from the specimen or by turning the gas off.

- 3.6.2.6 Note the times and/or locations on the specimen at which the following events occur:
- 3.6.2.6.1 If the flame front crosses the 1.5-inch (38-mm) gauge line, note the elapsed time in seconds, $t_e(1\ 1/2)$, at which the crossing occurs.
 - 3.6.2.6.2 If the flame front crosses the 11.5-inch (292-mm) gauge line, note the elapsed time in seconds, $t_e(11\ 1/2)$, at which the crossing occurs.
 - 3.6.2.6.3 If the specimen burns very slowly so that the flame front does not reach the 11.5-inch (292-mm) gauge line within 4 minutes after it passes the 1.5-inch (38-mm) gauge line, note the position in inches, d_f , of the flame front from the ignited end of the specimen and the elapsed time in seconds, $t_e(f)$, and terminate the test.
- 3.6.2.7 After all flaming ceases, open the cabinet door slowly to clear the test cabinet of fumes and smoke. The exhaust fan may be turned on to facilitate clearing of smoke and fumes. Remove any material from the bottom of the cabinet that fell from the specimen.
- 3.6.2.8 If necessary, clean the test cabinet window prior to testing the next specimen.

3.6.3 Test Results—Burn Rate

Determine the burn rate as follows:

- 3.6.3.1 If the flame front self-extinguished before crossing the 11.5-inch (292-mm) gauge line, record the burn rate as zero.
- 3.6.3.2 If the flame crosses the 11.5-inch (292-mm) gauge line, determine and record the burn rate as:
 Burn rate (in/min) = $600 / t_e(10)$, where $t_e(10) = t_e(11\ 1/2) - t_e(1\ 1/2)$ = time in seconds for the flame front to burn from the 1.5-inch (38-mm) gauge line to the 11.5-inch (292-mm) gauge line.
- 3.6.3.3 If the specimen burned very slowly (see section 3.6.2.6.3), the burn rate may be estimated and recorded as:

$$\text{Burn rate (in/min)} = 60 \times \frac{(d_f - 1.5)}{(t_e(f) - t_e(1\ 1/2))}$$

3.7 Report

3.7.1 Material Identification

Fully identify the material tested, including thickness.

3.7.2 Test Results

Report the burn rate from section 3.6.3 for each specimen tested. Determine and record the average value for burn rate.

3.8 Requirements

3.8.1 Burn rate

The average burn rate for all the specimens tested will not exceed 2.5 inches/minute for FAR 25.853(b-2) or 4 inches/minute for FAR 25.853(b-3), per Code of Federal Regulations (CFR), Title 14, January 1, 1990.

Chapter 3 Supplement

This supplement contains advisory material pertinent to referenced paragraphs.

3.2.1 Ignition time should start only after the flame has stabilized and is properly positioned under the test specimen.

3.3.1 Suitable test cabinets of the type described are manufactured by the U.S. Testing Co., 1415 Park Ave., Hoboken, New Jersey 07030; Atlas Electric Devices Co., 4114 N. Ravenswood Ave., Chicago, Illinois 60613; and The Govmark Organization, Inc., P.O. Box 807, Bellmore, New York 11710.

Draft free implies a condition of no air currents in a closed in space. One way of determining whether the cabinet is draft free is to place a smoldering and smoking material, such as a lighted cigarette, in the test cabinet, then closing the door and observing the behavior of the smoke for signs of drafts. A test cabinet other than one fabricated in accordance with figures 3-1 to 3-3 may be found to be acceptable after review by the FAA.

The entire inside back wall of the chamber may be painted flat black to facilitate viewing of the test specimen, and a mirror may be located on the inside back surface to facilitate observation of the hidden surfaces.

3.3.3 A suitable burner is available from Rascher & Betzold, Inc., 5410 N. Damen Ave., Chicago, Illinois 60625, Catalog No. R3726A.

3.3.3.1 Gases such as natural gas and propane can be used as burner fuel. However, it should be required to show compliance with the 1550°F minimum flame temperature using a 24 AWG thermocouple.

B-gas, which is the burner fuel specified in Federal Test Method 5903, meets minimum temperature requirements and is still used in some laboratories. However, its use has resulted in problems, and is not recommended. See note below for more details.

NOTE: B-gas, a mixture of 55 percent hydrogen, 18 percent carbon monoxide, 24 percent methane, and 3 percent ethane, has shown inconsistent burning characteristics in steel cylinders. A “spike” of varying intensity is produced. It has been postulated that the carbon monoxide in the gas may react with the iron in the steel cylinders to produce iron pentacarbonyl ($\text{Fe}(\text{CO})_5$), which is volatile and may cause interference with the normal flame characteristics and may be the cause of the erratic behavior. Because of the inconsistent flame characteristics, B-gas, at least if supplied in steel cylinders, is not recommended. No data are presently available about the suitability of B-gas supplied in cylinders of other materials, such as aluminum.

One noteworthy point that should be mentioned is the phenomenon that some labs have experienced with sharp decreases in flame temperature after the gas cylinders are approximately three-fourths empty. This has occurred primarily in labs that have single-stage regulators on their gas cylinders. Single-stage regulators differ from two-stage regulators in that control of the discharge pressure is not as accurate. Few designs maintain constant or near constant discharge pressures over the full range of cylinder pressures. Therefore, it is necessary to make adjustments periodically to allow for decreasing inlet pressures. Even the slightest drop in pressure should affect the flow rate of gas through the burner orifice. This, in turn, should cause temperature variation. By using a two-stage regulator or adjusting pressure on a single-stage regulator, as the cylinder gets low, this problem can be eliminated.

3.3.3.3 The tip of the methane flame is blue, transparent, and difficult to see. It is more easily seen if there is no light on the flame, as in a darkened room. The inner cone of the flame is, however, more visible and easily seen.

3.4.3 A 3-inch by 13-inch (76- by 330-mm) specimen can be used to secure the specimen at the end of the specimen holder.

3.4.4.1 According to the FAR 25.853, the specimen thickness must be no thicker than the minimum thickness to be qualified for use in the aircraft. If the test facility has found from experience or has questions concerning the flammability of a thicker specimen, then vertical testing may be conducted and test data recorded for further review.

3.5 As stated in the FAR 25.853, only one specimen may be removed at a time from the conditioning chamber prior to being subjected to the flame. Some facilities, however, have conditioning chambers located in areas remote from the testing area. In this case, it is permissible to remove more than one specimen at a time only if each specimen is placed in a closed container (a plastic stowage bag is acceptable) and protected from contamination such as dirty lab tops, soot in the air, etc., until the specimen is subjected to the flame.

3.6.2.3 It is important to note that the test should be watched carefully while it is being conducted. This applies to all samples.

3.6.2.5 Some laboratories turn the gas off upon completion of the test; however, the majority of test facilities, including the OEMs, withdraw the flame by moving the burner away from the specimen.

3.6.2.7 The operator should refer to the facility's safety manual for further information dealing with smoke and flammability by-products.

Chapter 4

60-Degree Bunsen Burner Test for Electric Wire

4.1 Scope

This test method is intended for use in determining the resistance of electric wire insulation to flame when tested according to the 30-second, 60-degree Bunsen burner test specified in FAR 25.869.

4.2 Definitions

4.2.1 Ignition Time

Ignition time is the length of time the burner flame is applied to the specimen. The ignition time for this test is 30 seconds.

4.2.2 Flame Time

Flame time is the time in seconds that the specimen continues to flame after the burner flame is removed from beneath the specimen. Surface burning that results in a glow but not in a flame is not included.

4.2.3 Drip Flame Time

Drip flame time is the time in seconds that any flaming material continues to flame after falling from the specimen to the floor of the chamber. If there is more than one drip, the drip flame time reported is that of the longest flaming drip. If succeeding flaming drips reignite earlier drips that flamed, the drip flame time reported is the total of all flaming drips.

4.2.4 Burn Length

Burn length is the length of damage along the wire above and below the point of burner flame impingement and due to that area's combustion, including areas of partial consumption, charring, or embrittlement, but not including areas sooted, stained, warped, or discolored nor areas where material has shrunk or melted away from the heat.

4.3 Apparatus

4.3.1 Test Enclosure and Setup

Tests will be conducted in a cabinet fabricated of sheet metal, approximately 24 inches (610 mm) high by 12 inches (305 mm) wide by 12 inches (305 mm) deep and open at the front and top. External conditions around the cabinet will be such that the cabinet is free of drafts during a test, but sufficient airflow will be available for complete combustion. Other cabinets may be used if they are draft free and have enough air to allow complete combustion. It is suggested that the cabinet be located inside an exhaust hood to facilitate removal of smoke and fumes after each test.

4.3.2 Specimen Holder

A specimen holder fabricated of corrosion-resistant metal in accordance with figure 4-1 will be used. The specimen holder will be placed so that the specimen is maintained at an angle of 60 degrees with the horizontal and is positioned parallel to and 6 inches (152 mm) back from the front of the enclosure.

4.3.2.1 Clamp and Pulley

The specimen will be attached to the specimen holder by a clamp at the lower end and a pulley or rod at the upper end. The span between the clamp and the rod or pulley will be 24 inches (610 mm).

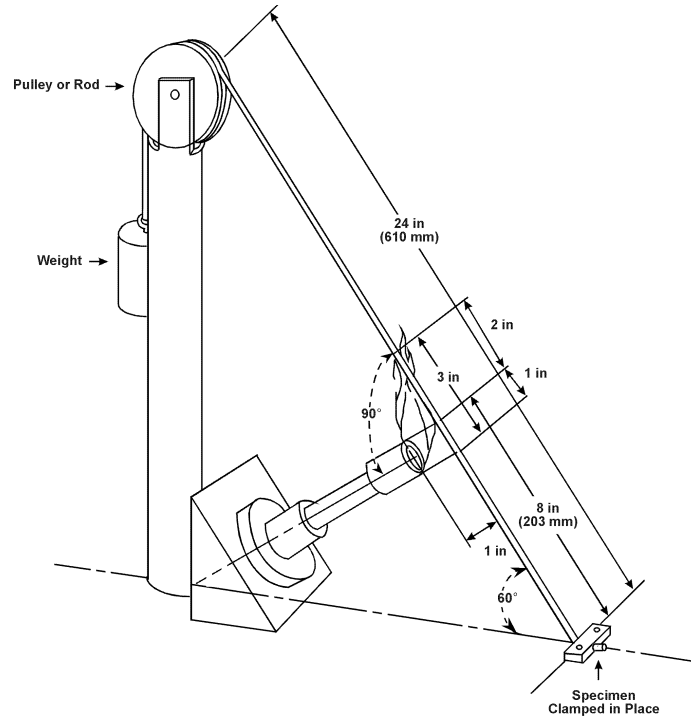

Figure 4-1. 60-Degree Electrical Wire Bunsen Burner Test Setup

4.3.2.2 Weight

A weight will be attached to the free end of the specimen to keep the specimen taut during the test (see figure 4-1). Suggested weights for various wire sizes are shown in table 4-1.

Table 4-1. Wire Size and Weight Suggestions

AWG	Pounds	Kg
20	0.8	0.4
14	2.0	0.9
8	3.0	1.4
1/0	11.0	5.0

4.3.3 Burner

The burner will be a Bunsen or Tirrill type, have a 3/8-inch (10-mm) inside diameter barrel and be equipped with a needle valve at the bottom of the burner barrel to adjust the gas flow rate (see figure 4-2). A means will be provided to move the burner into and out of the test position. Mounting the burner on a fixture that allows it to be rotated in the horizontal plane is suggested.

4.3.3.1 Burner Fuel

Methane gas (99 percent minimum purity) or other burner fuel acceptable to the FAA will be used. Methane is the preferred fuel. It can be used without adding air through the aspirating holes at the bottom of the burner barrel, i.e., a pure diffusion flame may be used.

4.3.3.2 Plumbing for Gas Supply

The necessary gas connections and the applicable plumbing will be essentially as shown in figure 4-2. A control valve system with a delivery rate designed to furnish gas to the burner under a pressure of $2 \frac{1}{2} \pm \frac{1}{4}$ lb/ft² (17 ± 2 kPa) at the burner inlet will be installed in between the gas supply and the burner.

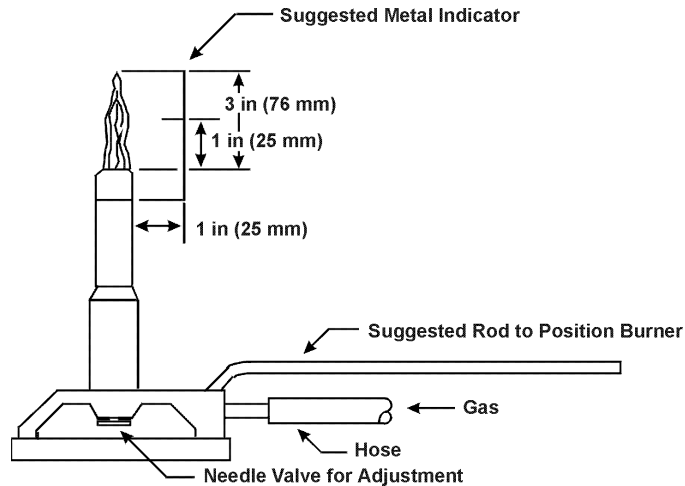

Figure 4-2. Burner Plumbing and Burner Flame Height Indicator

4.3.3.3 Flame Height Indicator

A flame height indicator may be used to aid in setting the height of the flame. A suitable indicator has a prong 3 inches (76 mm) above the top of the barrel, is attached to the burner barrel, spaced 1 inch (25 mm) from the burner barrel, and extends above the burner, as shown in figure 4-2. It is desirable to have two prongs to measure flame height, one prong to indicate the height of the inner cone of the flame and one prong to indicate the height of the tip of the flame. For this test, it has been determined that when the height of the inner cone is 1 inch (25 mm) and the tip of the flame is 3 inches (76 mm), the proper flame profile is achieved.

4.3.4 Timer

A stopwatch or other device graduated to the nearest 0.1 second will be used to measure the time of application of the burner flame, the flame time, and the drip flame time.

4.3.5 Ruler

A ruler or scale graduated to the nearest 0.1 inch (2.5 mm) will be provided to measure the burn length.

4.4 Test Specimens

4.4.1 Specimen Number

Each separate set of specimens prepared for testing will consist of at least three specimens (multiple places).

4.4.2 Specimen Length

The specimens will be cut to a length of 30 inches (762 mm). The specimen span between the lower clamp and upper pulley or rod will be 24 inches (610 mm).

4.4.3 Specimen Preparation

Make a gauge mark 8 inches (203 mm) from one end of each specimen.

4.5 Conditioning

Condition specimens at $70 \pm 5^\circ\text{F}$ ($21 \pm 3^\circ\text{C}$) and $50\% \pm 5\%$ relative humidity for 24 hours minimum unless otherwise specified. Remove only one specimen at a time from the conditioning environment immediately before being tested.

4.6 Procedure

4.6.1 Burner Adjustment

- 4.6.1.1 If using methane as the burner fuel, ensure that the air supply to the burner is shut off.
- 4.6.1.2 Open the stopcock in the gas line fully and light the burner.
- 4.6.1.3 Adjust the burner flame to obtain a flame profile so that the outer cone of the flame is 3 inches (76 mm) in length and the inner cone is approximately 1 inch (25 mm) in length. The proper flame length will be obtained by adjusting the needle valve on the burner controlling the gas flow rate.

4.6.1.4 Burner Placement

For the test, place the burner into position so that the top end of the burner barrel is 1 inch from the mark on the specimen, and the centerline of the burner barrel is perpendicular to the specimen and intersects the specimen at the mark (see figure 4-1).

4.6.2 Test Procedure

- 4.6.2.1 Place the burner at least 3 inches (76 mm) from where the specimen will be located during the test.
- 4.6.2.2 The timer must be started immediately upon positioning the burner. Position the burner as described in section 4.6.1.4 so that the tip of the inner cone of the burner flame contacts the gauge mark on the wire.
- 4.6.2.3 Apply the flame for 30 seconds, and then withdraw it.
- 4.6.2.4 If flaming material falls from the test specimen, note the drip flame time for the specimen (see section 4.2.3).
- 4.6.2.5 Determine the flame time for the specimen (see section 4.2.2).
- 4.6.2.6 After all flaming ceases, remove the specimen and determine the burn length (see section 4.2.4). To facilitate determining the burn length, a dry soft cloth or tissue or a soft cloth or tissue dampened with a moderate solvent that does not dissolve or attack the specimen material, such as alcohol, may be used to remove soot and stain particles from tested specimens.
- 4.6.2.7 Remove any material from the bottom of the cabinet that fell from the specimen.

4.7 Report

4.7.1 Material Identification

Fully identify the wire tested.

4.7.2 Test Results

- 4.7.2.1 Report the flame time for each specimen tested. Determine and record the average value for flame time.
- 4.7.2.2 Report the drip flame time for each specimen tested. Determine and record the average value for drip flame time. For specimens that have no drips, record "0" for the drip flame time and also record "No Drips."
- 4.7.2.3 Report the burn length for each specimen tested. Determine and record the average value for burn length.

4.8 Requirements

4.8.1 Extinguishing Time

The average extinguishing time for all the specimens tested will not exceed 30 seconds.

4.8.2 Drip Extinguishing Time

The average drip extinguishing time for all the specimens tested will not exceed 3 seconds.

4.8.3 Burn length

The average burn length for all the specimens tested will not exceed 3 inches (76 mm).

4.8.4 Wire Breakage

It will not be considered a failure if the wire breaks during the test.

Chapter 4 Supplement

This supplement contains advisory material pertinent to referenced paragraphs.

4.2.1 Ignition time should start only after the flame has stabilized and is properly positioned under the test specimen.

4.3.1 Draft free implies a condition of no air currents in a closed in space. One way of determining whether the cabinet is draft free is to place a smoldering and smoking material, such as a lighted cigarette, in the test cabinet, then closing the door and observing the behavior of the smoke for signs of drafts. A test cabinet other than one described in section 4.3.1 may be found to be acceptable after review by the FAA.

The entire inside back wall of the chamber may be painted flat black to facilitate viewing of the test specimen, and a mirror may be located on the inside back surface to facilitate observation of the hidden surfaces.

4.3.3 A suitable burner is available from Rascher & Betzold, Inc., 5410 N. Damen Ave., Chicago, Illinois 60625, Catalog No. R3726A.

4.3.3.1 Gases such as natural gas and propane can be used as burner fuel. However, it should be required to show compliance with the 1750°F minimum flame temperature using a 24 AWG thermocouple.

B-gas, which is the burner fuel specified in Federal Test Method Standard 5903, meets minimum temperature requirements and is still used in some laboratories. However, its use has resulted in problems and is not recommended. See note below for more details.

NOTE: B-gas, a mixture of 55 percent hydrogen, 18 percent carbon monoxide, 24 percent methane, and 3 percent ethane, has shown inconsistent burning characteristics in steel cylinders. A “spike” of varying intensity is produced. It has been postulated that the carbon monoxide in the gas may react with the iron in the steel cylinders to produce iron pentacarbonyl ($\text{Fe}(\text{CO})_5$), which is volatile and may cause interference with the normal flame characteristics and may be the cause of the erratic behavior. Because of the inconsistent flame characteristics, B-gas, at least if supplied in steel cylinders, is not recommended. No data are presently available about the suitability of B-gas supplied in cylinders of other materials, such as aluminum.

A phenomenon that some labs have experienced is a sharp decrease in flame temperature after about three-fourths of the gas originally in the cylinder has been used. This has occurred primarily in labs that have single-stage regulators on their gas cylinders. Single-stage regulators differ from two-stage regulators in that control of the discharge pressure is not as accurate. Few designs should maintain constant or near constant discharge pressures over the full range of cylinder pressures. Therefore, it is necessary to make adjustments periodically to allow for decreasing inlet pressures. Even the slightest drop in pressure should affect the flow rate of gas through the burner orifice. This, in turn, should cause temperature variation. By using a two-stage regulator or adjusting pressure on a single-stage regulator, as the cylinder gets low, this problem can essentially be eliminated.

4.5 As stated in FAR 25.853, only one specimen may be removed at a time from the conditioning chamber prior to being subjected to the flame. Some facilities, however, have conditioning chambers located in areas remote from the testing area. In this case, it is permissible to remove more than one specimen at a time only if each specimen is placed in a closed container (a plastic stowage bag is acceptable) and protected from contamination such as dirty lab tops, soot in the air, etc., until the specimen is subjected to the flame.

4.6.1.4 Alternative Burner Placement

Place the burner into position so that the top end of the burner barrel is 1 inch from the mark on the specimen. Make sure the centerline of the burner barrel is perpendicular to the underside of the mark on the specimen, that the centerline of the burner barrel forms an angle of 30 degrees with the line that is in the vertical plane containing both ends of the specimen, is perpendicular to the specimen, and passes through the mark on the specimen. It has been

found convenient to fabricate a fixture to position and hold the location of the burner quickly and repeatably (see figure 4-3).

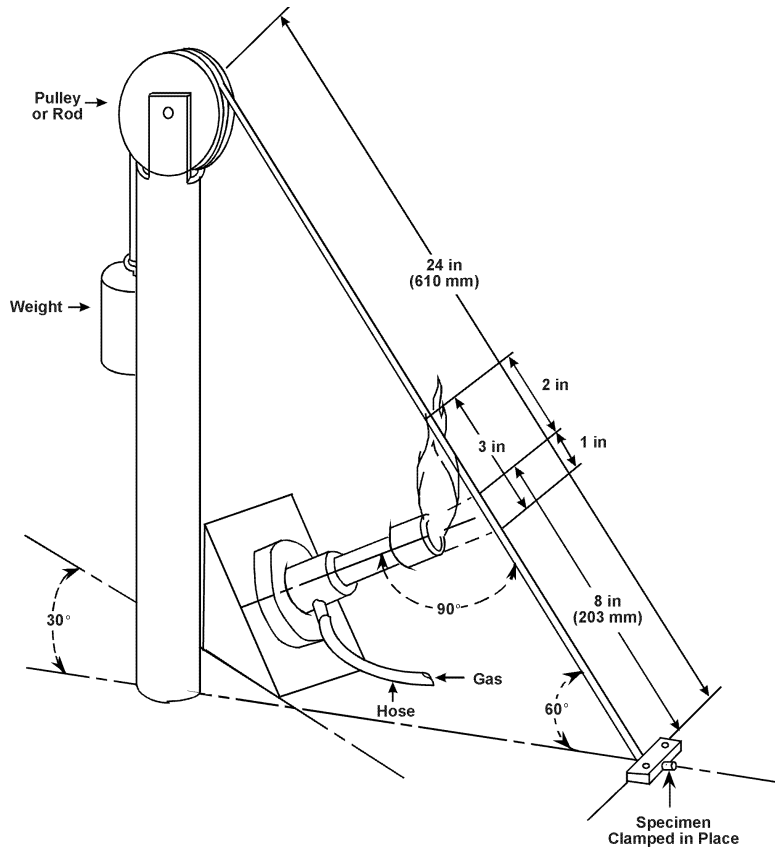

Figure 4-3. Alternative Setup for 60-Degree Electrical Wire Bunsen Burner Test

4.6.2.3 It is important to note that the test should be watched carefully while it is being conducted. This applies to all samples.

4.6.2.6 The operator should refer to the facility's safety manual for further information dealing with smoke and flammability by-products.

NOTE: The Alternative Burner Placement conforms to the 30-second, 60-degree Bunsen burner test described in FAR 25, Appendix F, Part I through Amendment 25-72. The FAA William J. Hughes Technical Center has determined that the Burner Placement in section 4.6.1.4 produces equivalent test results.

Chapter 5 Heat Release Rate Test for Cabin Materials

5.1 Scope

- 5.1.1 This test is intended for use in determining heat release rates to show compliance with the requirements of FAR 25.853.
- 5.1.2 Heat release rate is measured for the duration of the test from the moment the specimen is injected into the controlled exposure chamber and encompasses the period of ignition and progressive flame involvement of the surface.

5.2 Definitions

5.2.1 Heat Release

Heat release is a measure of the amount of heat energy evolved by a material when burned. It is expressed in terms of energy per unit area (kilowatt minutes per square meter—kW min/m²).

5.2.2 Heat Release Rate

Heat release rate is a measure of the rate at which heat energy is evolved by a material when burned. It is expressed in terms of power per unit area (kilowatts per square meter—kW/m²). The maximum heat release rate occurs when the material is burning most intensely.

5.2.3 Heat Flux

Heat flux density is the intensity of the thermal environment to which a sample is exposed when burned. In this test, the heat flux density used is 3.5 W/cm².

5.3 Test Apparatus

5.3.1 Release Rate Apparatus

The apparatus shown in figures 5-1a and 5-1b will be used to determine heat release rates. All exterior surfaces of the apparatus, except the holding chamber, will be insulated with 1-inch (25-mm) thick, low-density, high-temperature, fiberglass board insulation. A gasketed door through which the sample injection rod slides will be provided to form an airtight closure on the specimen holding chamber.

5.3.2 Thermopile

The temperature difference between the air entering and leaving the environmental chamber will be monitored by a thermopile having five hot and five cold 24-gauge chromel-alumel junctions (see figure 5-2). The bead to be formed by the thermocouple junction will be 0.050 ± 0.010 inch (1.3 ± 0.3 mm) in diameter. Each junction will be free of insulation for a minimum of 0.75 inch (19 mm). The cold junctions will be located in the pan below the air distribution plate (see section 5.3.4). The hot junctions will be located 0.38 inch (10 mm) below the top of the chimney. One of the hot junctions will be placed at the center of the chimney's cross section, and the other four will be placed on the chimney diagonals, 1.18 inches (30 mm) from the center thermocouple.

5.3.3 Radiant Heat Source

A radiant heat source for generating a flux up to 10 W/cm², using four silicon carbide elements Type LL, 20 inches (508 mm) by 0.63 inch (16 mm), nominal resistance 1.4 ohms, as shown in figures 5-1a, 5-1b, and 5-3, will be used. The silicon carbide elements will be mounted in the stainless steel panel box by inserting them through 0.63 inch (16-mm) holes in ceramic insulating devices or calcium-silicate millboard. Locations of the holes in the pads and stainless steel covered plates will be as shown in figure 5-3. A truncated, diamond-shaped mask, constructed of 0.042 ± 0.002 inch (1.07 ± 0.05 mm) stainless steel, will be added to provide uniform heat flux density over the area occupied by the 5.94- by

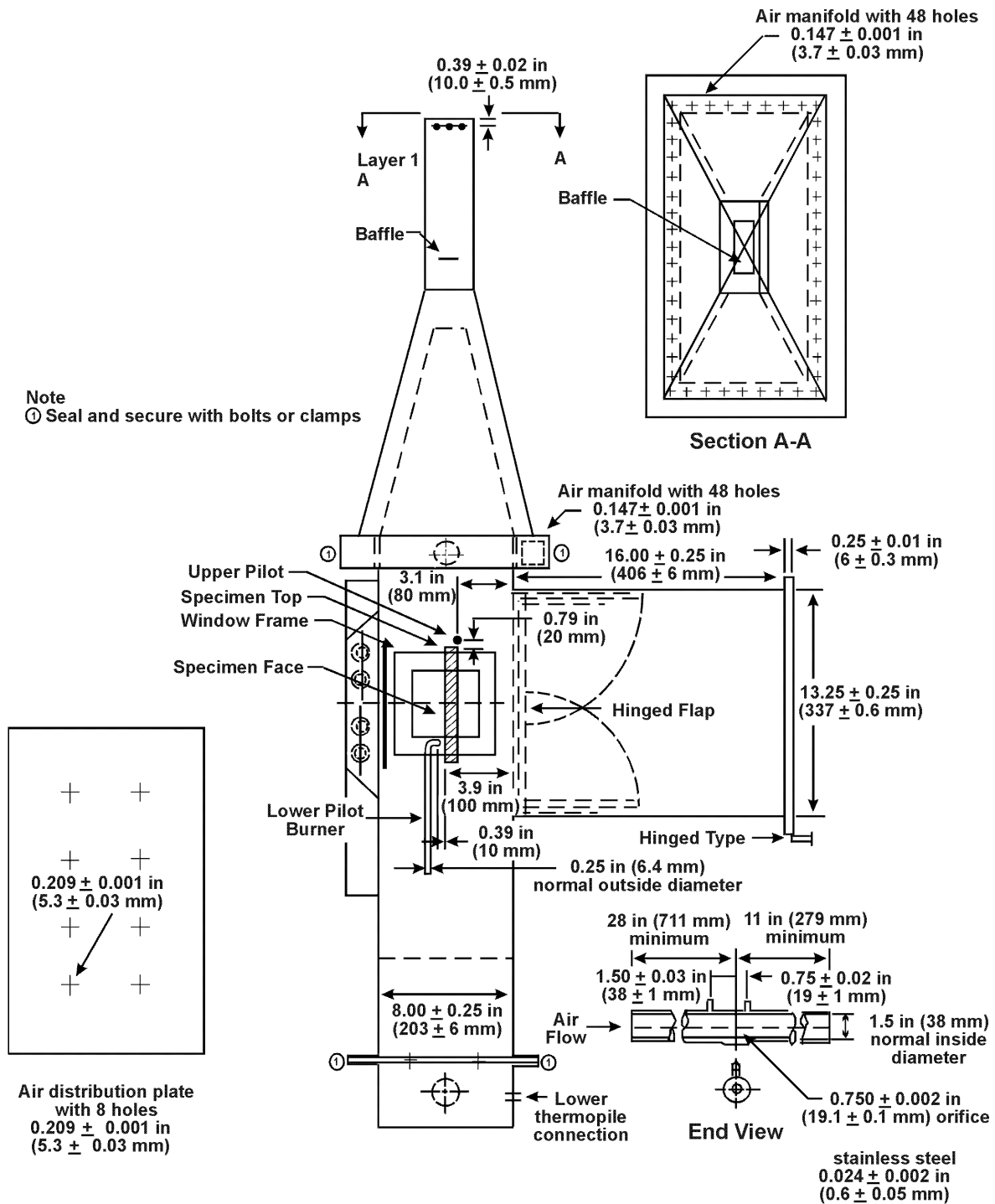

Figure 5-1a. Rate of Heat Release Apparatus

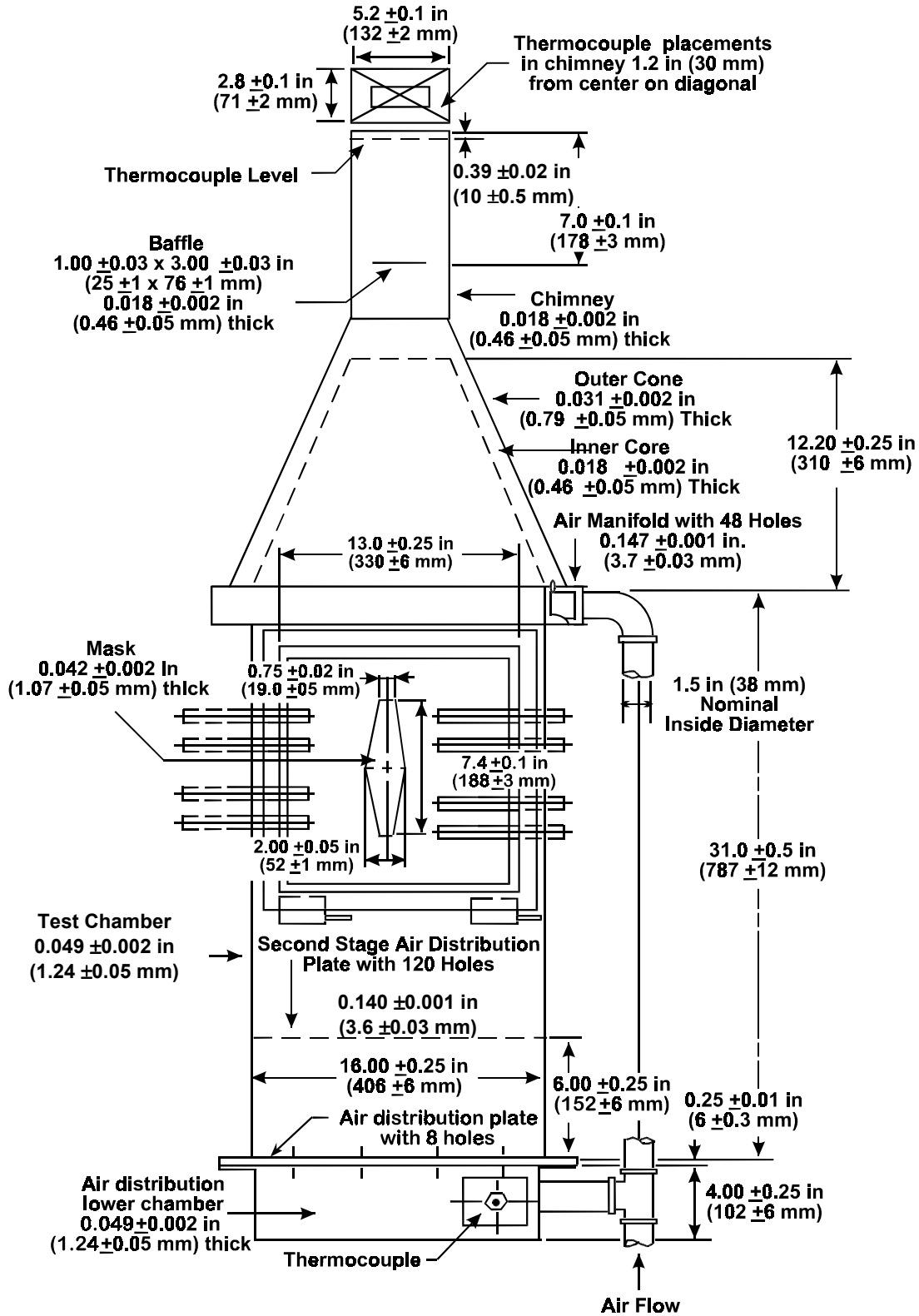

Figure 5-1b. Rate of Heat Release Apparatus

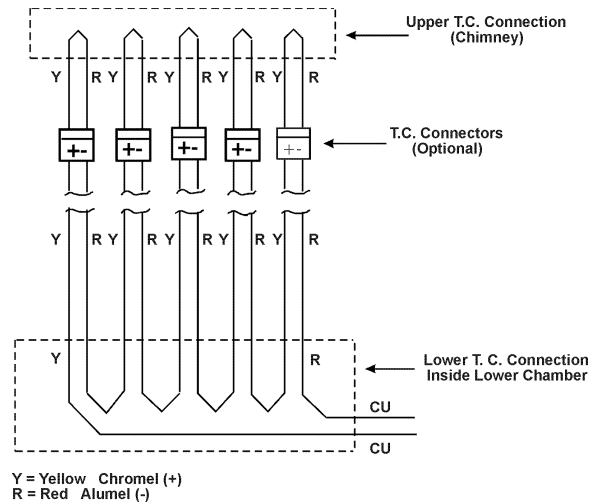

Figure 5-2. Thermopile

5.94-inch (151- by 151-mm) vertical sample. An adjustable power supply capable of producing 12.5 kVA will be provided. The heat flux over the specimen surface when set at 3.5 W/cm^2 will be uniform within 5 percent and will be checked periodically and after each heating element change. Uniformity of heat flux density will be determined by heat flux sensor measurements at the center and at the four corners of the specimen surface.

5.3.4 Air Distribution System

The air entering the apparatus will be 70 to 75°F (21 to 24°C) and set at approximately 85 ft³/min (0.04 m³/s) using an orifice meter. The orifice meter will be comprised of a squared-edged, circular plate orifice, 0.024 inch (0.5 mm) thick, located in a circular pipe with a nominal diameter of 1.5 inches (38 mm), with two pressure measuring points located 1.5 inches (38 mm) upstream (above) and 0.75 inch (19 mm) downstream (below) the orifice and connected to a mercury manometer. The inlet pipe will remain a nominal diameter of 1.5 inches (38 mm) (see figure 5-1a).

5.3.4.1 The air entering the environmental chamber will be distributed by a 0.25-inch (6.3-mm) -thick aluminum plate having eight 0.209- ± 0.001-inch (5.3- ± 0.03-mm) -diameter holes, 2 inches (51 mm) from the sides on 4-inch (102-mm) centers, mounted at the base of the environmental chamber. A second plate having 120 evenly spaced, 0.140- ± 0.001-inch (3.6- ± 0.03-mm) -diameter holes, will be mounted 6 inches (152 mm) above the aluminum plate (see figure 5-1b).

5.3.4.2 The air supply manifold at the base of the pyramidal section will have 48 evenly spaced, 0.147- ± 0.001-inch (3.7- ± 0.03-mm) -diameter holes 0.38 inch (10 mm) from the inner edge of the manifold, resulting in an airflow split of approximately three to one within the apparatus (see figure 5-1a).

5.3.5 Exhaust Stack

An exhaust stack, 5.25 by 2.75 inches (133 by 70 mm) in cross section and 10 inches (254 mm) long, fabricated from stainless steel, 0.018 ± 0.002 inch (0.46 ± 0.05 mm), will be mounted on the outlet of the pyramidal section (see figures 5-1a and 5-1b). A 1- by 3-inch (25- by 76-mm) plate of 0.018- ± 0.002-inch (0.46- ± 0.05-mm) -thick stainless steel will be centered inside the stack, perpendicular to the airflow, 3 inches (76 mm) above the base of the stack.

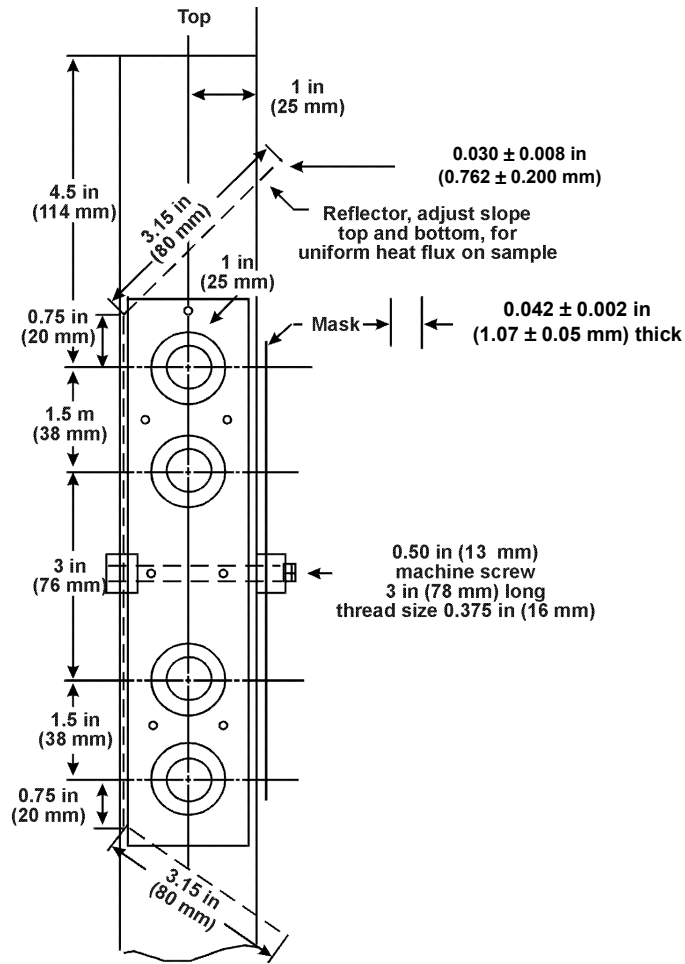

Figure 5-3. Side View—Global Radiant Heat Panel

5.3.6 Specimen Holders

Specimen holders will be fabricated from a stainless steel sheet, 0.018 ± 0.002 inch (0.46 ± 0.05 mm) thick, as shown in figure 5-4. Specimen holders will be attached to the injection rod using the mounting bracket shown in figure 5-4. Each holder will be provided with a V-shaped spring pressure plate. The position of the spring pressure plate can be changed to accommodate different specimen thicknesses by inserting the retaining rod in different holes of the specimen holder frame. Each holder will also have two wires attached vertically to the front of the holder to secure the face of the specimen in the holder.

5.3.6.1 Drip Pan

A drip pan will be fabricated from a stainless steel sheet, 0.018 ± 0.002 inch (0.46 ± 0.05 mm) thick, as shown in figure 5-4, and be attached to the specimen holder using the flanges shown in figure 5-4. Drip pans may be needed to prevent melting specimens from dripping into the lower test section. Foil can be used to line the drip pan to facilitate cleaning after use.

5.3.7 Heat Flux Sensor

A water-cooled, foil-type Gardon Gauge heat flux sensor will be used to measure the heat flux density at a point where the center of the specimen surface is located at the start of the test. When positioned to measure heat flux density, the sensor surface will be flush with the supporting device surface so that air heated by such a support does not contact the sensor surface.

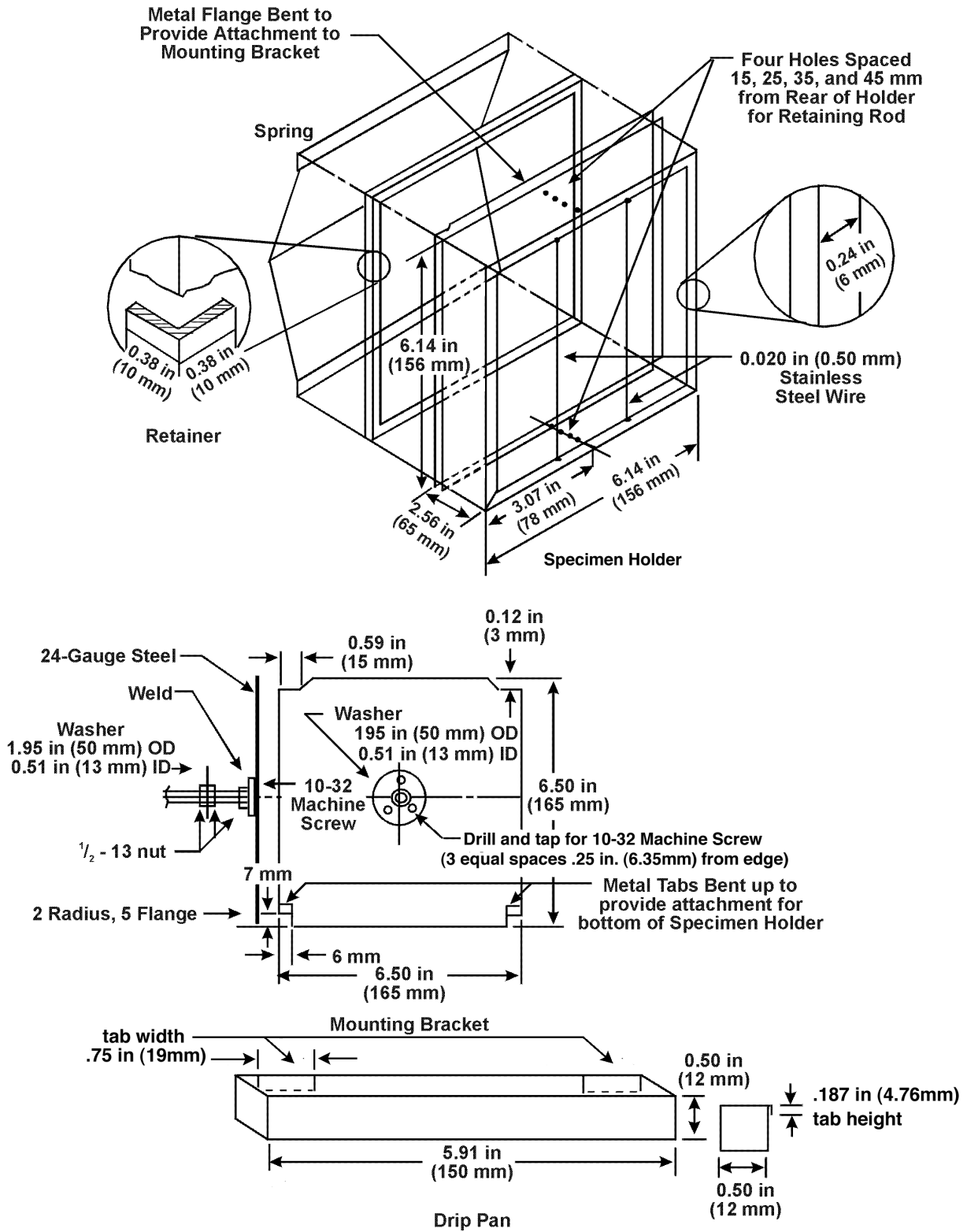

Figure 5-4. Heat Release Specimen Holder, Mounting Bracket, and Drip Pan

5.3.8 Pilot Burners

Pilot burners will be placed at locations near the bottom and top of the specimens (see figure 5-1a). The burners will be constructed of stainless steel tubing with a 0.25-inch (6.4-mm) outside diameter and 0.03-inch (0.8-mm) wall thickness.

5.3.8.1 Lower Pilot Burner

The lower pilot burner will be located as shown in figure 5-1a. The lower pilot burner will have its centerline perpendicular to the surface of the specimen and 0.19 inch (5 mm) above the specimen's lower exposed edge and will have its end 0.38 inch (10 mm) from the specimen surface. A methane-air mixture will be used, consisting of 0.004 ft³/min (120 cm³/min) (at standard temperature and pressure) methane (99 percent minimum purity) and an air supply adjusted to produce a flame such that the inner cone is approximately the same length as the diameter of the burner tube. (See figure 5.5.)

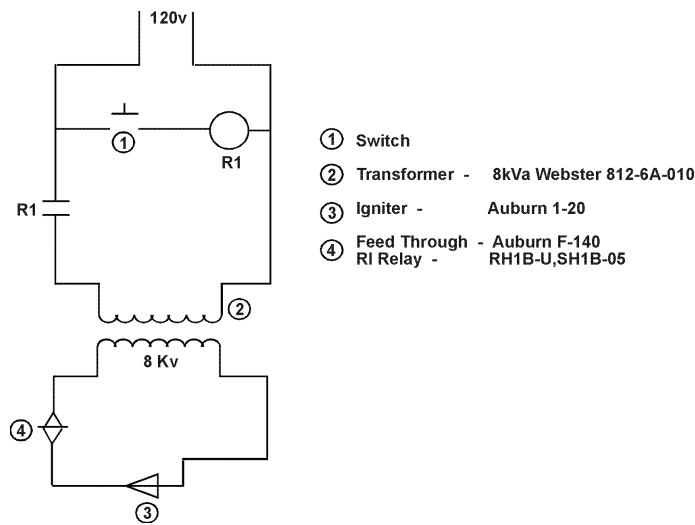

Figure 5-5. Lower Pilot Burner Igniter Schematic

5.3.8.2 Upper Pilot Burner

An upper pilot burner will be provided to produce 15 flamelets above the test specimen to ignite flammable gases (see figure 5-6). During the test, if there is any period of time longer than 3 seconds when any three or more of the flamelets on the upper pilot burner are not burning, the test is invalidated.

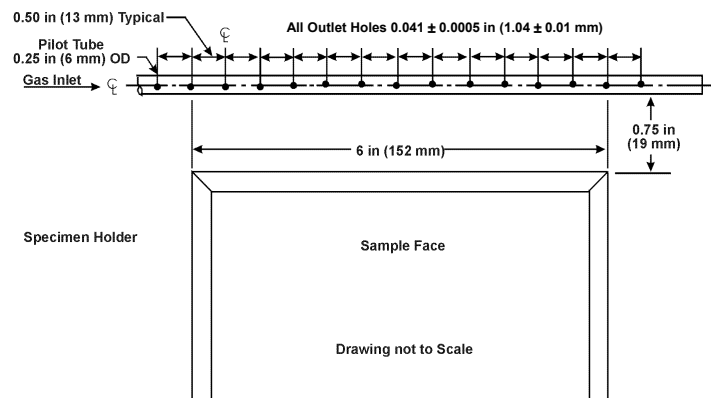

Figure 5-6. Upper Pilot Burner - 15 Hole Burner

- 5.3.8.2.1 The upper pilot burner will be constructed from a piece of stainless steel tubing with an outside diameter (OD) of 0.25 inch (6.3 mm) and a wall thickness of 0.03 inch (0.8 mm). Fifteen 0.041 ± 0.0005 -inch (1.04 ± 0.01 -mm) -diameter holes, each radiating in the same direction, will be drilled into a 15-inch (381-mm) length of tubing. The holes will be spaced 0.5 inch (13 mm) apart with the first hole located 0.5 inch (13 mm) from the closed end, as shown in figure 5-6. The tubing will be inserted into the environmental chamber through a 0.25-inch (6.3-mm) hole drilled to locate the tubing 0.79 inch (20 mm) above and 0.79 inch (20 mm) behind the upper front edge of the specimen holder and installed so that the holes are directed horizontally toward the radiant heat source. One end of the tubing will be closed with a silver solder plug or equivalent.
- 5.3.8.2.2 The burner will be positioned above the specimen holder so that the holes are placed above the specimen holder facing the heat source, as shown in figure 5-1a.
- 5.3.8.2.3 The fuel fed to this burner will be methane of 99 percent minimum purity mixed with air in a ratio of approximately 50/50 by volume. The total fuel flow will be adjusted to provide flamelets approximately 1 inch (25 mm) long. When the gas/air ratio and its fuel flow rate are properly adjusted, approximately 0.25 inch (6 mm) of the flame length appears yellow in color.

5.4 Test Specimens

5.4.1 Specimen Size

The standard size for specimens is $5.94 + 0, -0.06$ by $5.94 + 0, -0.06$ inches ($150 + 0, -2$ by $150 + 0, -2$ mm) in lateral dimensions. Specimen thickness is as used in the relevant application up to 1.75 inches (45 mm); applications requiring thicknesses greater than 1.75 inches (45 mm) will be tested in 1.75-inch (45-mm) thicknesses.

5.4.2 Specimen Number

A minimum of three specimens will be prepared and tested for each material/part.

5.4.3 Specimen Mounting

Only one surface of a specimen will be exposed during a test. A single layer of 0.0012 ± 0.0005 -inch (0.03 ± 0.01 -mm) -thick aluminum foil will be wrapped tightly on all unexposed sides with the dull side of the foil facing the specimen surface. The foil must be continuous and not torn. The retaining frame will be placed behind the specimen between the back of the specimen and the pressure plate.

5.4.4 Specimen Orientation

For materials that may have anisotropic properties (i.e., different properties in different directions, such as machine and cross-machine directions for extrusions, warp and fill directions of woven fabrics, etc.), the specimens will be tested in the orientation thought to give the highest results. If the average maximum heat release rate exceeds 58 kW/m^2 or the average total heat released during the first 2 minutes exceeds 58 kW min/m^2 , a second set of specimens will be prepared and tested in the orientation that is perpendicular to the orientation used for the first set of specimens. The higher value for the average maximum heat release rate and the higher value for the average total heat released during the first 2 minutes will be reported.

5.5 Conditioning

- 5.5.1 Specimens will be conditioned at $70 \pm 5^\circ\text{F}$ ($21 \pm 3^\circ\text{C}$) and $50\% \pm 5\%$ relative humidity for a minimum of 24 hours prior to test.

5.6 Calibration

5.6.1 Calibration Burner

A calibration burner, as shown in figure 5-7, will be provided that fits over the end of the pilot flame tubing with a gas-tight connection. T-bar outlets will be approximately the same height as the lower pilot outlet.

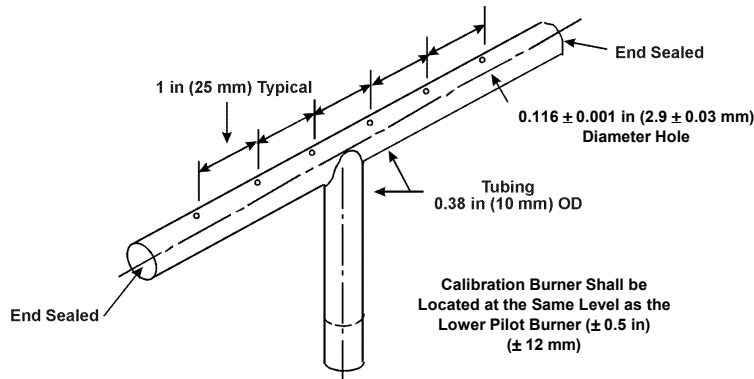

Figure 5-7. Typical Calibration Burner

5.6.2 Calibration Gas

Methane of at least 99 percent purity will be used for calibration purposes.

5.6.3 Wet Test Meter

A wet test meter accurate to 0.007 ft³/min (0.2 L/min) will be provided to measure the gas flow rate to the calibration burner. Prior to usage, the wet test meter will be leveled and filled with distilled water to the tip of the internal pointer, according to manufacturer instructions.

5.6.4 Calibration Gas Manifold

5.6.4.1 A means will be provided upstream of the wet test meter to control calibration gas flow. The means will have flow orifices preset to provide calibration gas at approximate (uncorrected for the presence of water vapor) flow rates of 0.035, 0.14, 0.21, and 0.28 ft³/min (1, 4, 6, and 8 L/min), as indicated by revolution rate (measured by a stop watch accurate to 1 second) of the wet test meter. Output from each of the flow orifices will be controlled by an on/off means and be plumbed into a single-flow line so that the calibration gas flow rate to the calibration burner can be set at 0.035, 0.14, 0.21, or 0.28 ft³/min (1, 4, 6, and 8 L/min).

5.6.4.2 The actual, corrected value, F, of each of the flow rates will be determined to an accuracy of 0.007 ft³/min (0.2 L/min), and these corrected values are used for calibration calculations in section 5.6.6.

5.6.5 Calibration Procedure

5.6.5.1 Replace the lower pilot burner with the calibration burner shown in figure 5-7.

5.6.5.2 Install the wet test meter. Ensure that it is leveled and filled with distilled water. Ambient temperature and water pressure are based on the internal wet test meter temperature.

5.6.5.3 Turn on the air distribution system.

5.6.5.4 Turn on the radiant heat source and ensure that the heat flux is 3.5 ± 0.05 W/cm².

5.6.5.5 Using the calibration gas manifold, set the baseline flow rate of 1 L/min of methane to the calibration burner and light the burner. Measure the thermopile baseline voltage.

- 5.6.5.6 Immediately prior to recording the thermopile outputs, as discussed in section 5.6.5.7, precondition the chamber at a methane flow rate of 8 L/min for 2 minutes. Do not record the thermopile output for this step as part of the calibration.
- 5.6.5.7 The gas flow to the burner is increased to a higher flow rate and then decreased to the baseline flow rate. After 2 minutes of burning at each rate, monitor the thermopile output (millivolts) for a 10-second period, record the average reading, and decrease the flow rate to the baseline flow of 1 L/min. This sequence of increasing and decreasing the methane flow rate is as follows: 0.035 - 0.14 - 0.035 - 0.21 - 0.035 - 0.28 - 0.035 - 0.21 - 0.035 - 0.14 ft³/min (1 - 4 - 1 - 6 - 1 - 8 - 1 - 6 - 1 - 4 L/min).
- 5.6.6 Compute the calibration factor for each upward rate step (i.e., 1 - 4, 1 - 6, 1 - 8, 1 - 6, 1 - 4 L/min) according to the following formula:

$$k_h = 23.55 \times \frac{273}{T_a} \times \frac{(P_a - P_v)}{760} \times \frac{(F_1 - F_0)}{(V_1 - V_0)} kW / m^2 - mv$$

where:

- F_1 = Actual upper flow rate of calibration gas, in L/min (either 4, 6, or 8)
- F_0 = Actual baseline flow rate of methane, in L/min (approximately 1 L/min)
- P_a = Ambient atmospheric pressure, in mm Hg
- P_v = Water vapor pressure of wet test meter water temperature, in mm Hg
- T_a = Ambient temperature, in °K
- V_1 = Thermopile voltage at upper flow rate, in *mv*
- V_0 = Thermopile voltage at baseline flow rate, in *mv*

- 5.6.7 Average the five results and compute the percent relative standard deviation. If the percent relative standard deviation is greater than 5 percent, repeat the determination. If it is less than 5 percent, use the average as the calibration factor.

5.7 Test Procedure

- 5.7.1 Set the airflow to the equipment by adjusting the pressure differential across the orifice plate to 7.87 inches (200 mm) of mercury.
- 5.7.2 Set the power supply to the Globars to produce a radiant flux density of 3.5 ± 0.05 W/cm² at the point that the center of the front surface of the specimen will occupy when positioned for test.
- 5.7.3 Light the pilot flames and check that their positions are as described in sections 5.3.8.1 and 5.3.8.2. Activate the spark igniter if a spark igniter is used.
- 5.7.4 If the test specimen consists of material that sags and/or drips to the extent that part of it may fall out of the holder during the test, attach the drip pan to the specimen holder, as described in section 5.3.6.1.
- 5.7.5 Place the specimen in the hold chamber with the radiation shield doors closed. Secure the airtight outer door and start the recording devices. Hold the specimen in the hold chamber for 60 ± 10 seconds.
- 5.7.6 Record, at least once a second, the thermopile millivolt output during the final 20 seconds of the hold time before the specimen is injected, and report the average as the baseline thermopile reading (millivolts).
- 5.7.7 After recording the baseline reading and within a timeframe not exceeding 3 seconds, open the radiation doors, inject the specimen into the burn chamber, and close the radiation doors. Record thermopile millivolt outputs at least once a second for the duration of the test.
- 5.7.8 After the test has run for 5 minutes, terminate the test and remove the sample.
- 5.7.9 Observe and note any extinguishment of pilot flames then discard data from any test during which the lower pilot burner was extinguished for any period of time exceeding 3 seconds or during which at least

three of the upper pilot flamelets were extinguished simultaneously for any period of time exceeding 3 seconds.

- 5.7.10 Calculate the heat release rate for any point of time from the reading of the thermopile output voltage, V at that time as heat release rate = $k_h \times (V_1 - V_0)$, where k_h and V_0 are the calibration factor and thermopile millivolt reading at the baseline, respectively.
- 5.7.11 Determine and record the maximum heat release rate during the 5-minute test.
- 5.7.12 Compute and record the total heat released during the first 2 minutes of testing by integrating the heat release rate versus time curve during the first 2 minutes.
- 5.7.13 Clean the thermopile hot junctions to remove soot after testing each set of specimens.

5.8 Report

- 5.8.1 Fully identify the material tested, including thickness.
- 5.8.2 Determine and record the average maximum heat release rate during the 5-minute test, and the average total heat released during the first 2 minutes for all specimens tested (in worst-case direction).
- 5.8.3 Report the radiant heat flux to the specimen in W/cm^2 and data giving release rates of heat (in kW/m^2) as a function of time, either graphically or tabulated at intervals no greater than 10 seconds, and the calibration factor k_h .
- 5.8.4 Report any melting, sagging, delamination, or other behavior that affected the exposed surface area or mode of burning that occurred and the time(s) at which such behavior occurred.

5.9 Requirements

- 5.9.1 The average maximum heat release rate during the 5-minute tests will not exceed $65 \text{ kW}/\text{m}^2$.
- 5.9.2 The average total heat released during the first 2 minutes will not exceed $65 \text{ kW min}/\text{m}^2$.

NOTE: The 65/65 acceptance criteria above are the definitive requirements in FAR 25, Amendment 25-61 (FAR 25.853[a-1]), covering affected new design airplanes whose Type Certificate is applied for after August 20, 1986. These definitive requirements are referenced in FAR 121, Amendment 121-189, and are required for all affected airplanes manufactured after August 20, 1990. All affected airplanes manufactured after August 20, 1988, but prior to August 20, 1990, must meet interim requirements of $100 \text{ kW}/\text{m}^2$ for the average heat release rate and $100 \text{ kW min}/\text{m}^2$ for the average total heat released during the first 2 minutes.

Chapter 5 Supplement

This supplement contains advisory material pertinent to referenced paragraphs.

5.3.2 The upper thermocouples in the thermopile must remain in the same position as when the last calibration was completed. A template may be necessary to maintain this position. Caution must be taken while cleaning the thermocouple junctions not to move them.

5.3.3 A device should be provided to monitor the current of the heating elements (globars) during testing; additionally, this may be used to adjust the globar current during initial warm up, before final adjustment.

5.3.4 The air distribution system circular plate orifice should be no thicker than 0.125 inch. The inner edges of the holes must be sharp. The holes in the lower plate are #4 drill size. The holes in the upper manifold are #26 drill size. The holes in the intermediate plate used for air flow disbursement are #28 drill size.

5.3.5 The exhaust stack and area above the upper manifold should be cleaned periodically of soot deposits.

5.3.7 A second calorimeter should be used periodically to check the active calorimeter and its calibration should be first generation from National Institute of Standards and Technology (NIST) or the calorimeter manufacturer.

5.3.8 A method to provide reignition of the lower pilot flame is recommended. A spark ignitor should be installed to ensure that the lower pilot burner remains burning. A test is invalidated if the lower pilot burner becomes extinguished for any period that exceeds 3 seconds. A circuit for a satisfactory device is sketched in figure 5-5.

If an electric sparking device is used, an appropriate method of suppression and equipment shielding must be applied to have no interference with the ability of the data acquisition equipment to accurately record data.

5.3.8.2 The upper pilot holes are #59 drill size.

5.4.1 *to be added: reducing thickness of sample*

5.4.2 For test purposes, specimens should be marked with an arrow by manufacturers or operators for a consistent direction.

5.4.4 If there is evidence that a material does not demonstrate isotropic flammability characteristics and its heat release numbers in any one direction average greater than 58, either 2 minute or peak, the material must be tested in both directions. Examples of those types of materials that may not exhibit isotropic flammability characteristics are rugs and textiles.

5.6.1 The calibration T-bar burner holes are #32 drill size.

5.6.3 The tubing from the wet test meter to the calibration T-bar must be as short as possible and direct in routing. Also, the wet test meter must be last in line to the calibration T-bar.

5.7.6 Extreme caution must be used to ensure that the baseline reading is completed prior to opening inner doors for sample injection.

5.7.9 The use of an externally positioned mirror may assist in viewing upper pilot flames during testing.

5.7.13 A small, soft-bristled brush has been found satisfactory. Do not disturb the position of the thermocouples. Ensure that the thermocouples are in their proper position before proceeding with the next specimen; a template may be used to facilitate this step.

Chapter 6 Smoke Test for Cabin Materials

6.1 Scope

- 6.1.1 This test method is used to determine the smoke generating characteristics of airplane passenger cabin interior materials to demonstrate compliance with the requirements of FAR 25.853.

6.2 Definitions

- 6.2.1 Specific Optical Density (D_s)-Specific Optical Density

Specific optical density (D_s)-specific optical density is a dimensionless measure of the amount of smoke produced per unit area by a material when it is burned. In this test, the maximum value of D_s that occurs during the first 4 minutes of a test, 4D_m , is reported.

6.3 Test Apparatus

- 6.3.1 Required Equipment

The test chamber and related equipment (e.g., radiant heat furnace, heat flux density gauge, specimen holders, photometric system, multidirectional pilot burner, etc.) are defined as follows.

- 6.3.1.1 Test Chamber

The test chamber will be a square-cornered box with inside dimensions of 36 ± 0.13 inches (914 ± 3 mm) wide, 24 ± 0.13 inches (610 ± 3 mm) deep, and 36 ± 0.13 inches (914 ± 3 mm) high. A typical test chamber is shown in figure 6-1. The location or size of items such as the chamber door, chamber controls, flowmeters, etc., is optional except as mandated in the following sections.

- 6.3.1.1.1 The interior surfaces (except for the chamber door, vents, etc.) will be porcelain-enameled metal or equivalent coated metal that is resistant to chemical attack and corrosion and suitable for periodic cleaning. The chamber will be equipped with a door such as that indicated in figure 6-1 to provide convenient access for changing test specimens and for cleaning the chamber walls as required. The door will have a viewing window to observe the sample and pilot flamelets behavior during a test, especially when any of the flamelets extinguish (see section 6.7.2.10).

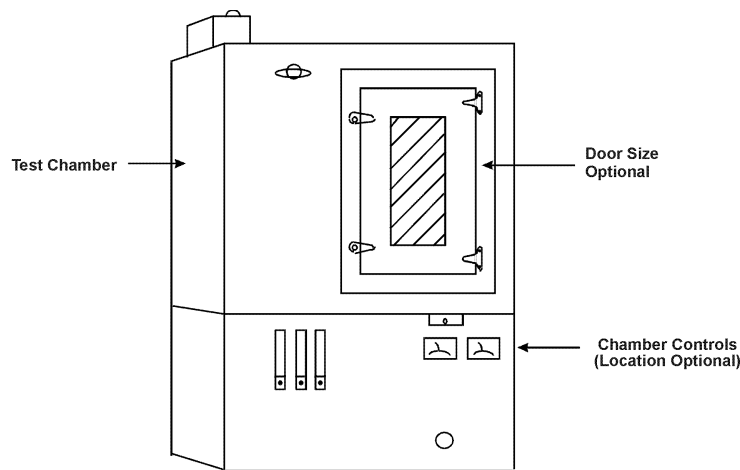

Figure 6-1. Typical Smoke Density Chamber

6.3.1.1.2 An inlet-outlet vent for pressure equalization will be provided. The vent and chamber door will have a seal so that when it is closed during tests, there will be no leakage of chamber contents and a small positive pressure can be developed and maintained inside the test chamber.

6.3.1.2 Manometer

A device such as a manometer or pressure transducer will be provided to monitor chamber pressure and leakage. The device will have a range up to 6 inches (152 mm) of water and be connected to a suitable port in the test chamber.

6.3.1.3 Pressure Regulator

A pressure regulator will be provided that consists of a water-filled bottle vented to a suitable exhaust system and a piece of tubing, not to exceed 10 feet (305 cm) in length, that has an inside diameter of at least 1 inch (25 mm). One end of the tubing will be connected to a port within 6 inches of the top of the chamber; the other end of the tubing will be held in position 4 inches (102 mm) below the water surface.

6.3.1.4 Test Chamber Wall Thermocouple

The temperature of the test chamber wall will be monitored by a thermocouple suitable for measuring a temperature of 35°C. The thermocouple will be mounted with its junction secured to the geometric center of the inner rear wall panel of the chamber using an electrically insulating disk cover.

6.3.1.5 Electric Power

A single-phase electric power of 650 W of 115 V, 60 Hz will be provided for the radiant heat furnace and accessories. Where line voltage fluctuations exceed 2.5 percent, a constant voltage transformer will be provided.

6.3.1.6 Radiant Heat Furnace

An electric furnace and associated controlling devices (see figures 6-2 and 6-3) will be provided that are capable of providing a constant thermal flux density of $2.5 \pm 0.05 \text{ W/cm}^2$ ($2.2 \pm 0.04 \text{ Btu/ft}^2/\text{second}$) on the specimen surface.

6.3.1.6.1 Furnace Construction

The dimensions shown in figure 6-2 for the electric furnace are critical. The furnace will be located centrally along the long axis of the chamber, with the opening facing toward and approximately 12 inches (305 mm) from the right wall. The centerline of the furnace will be approximately 7.75 inches (197 mm) above the chamber floor.

6.3.1.6.2 Heating Element

The heating element will consist of a coiled wire capable of dissipating about 525 W. With the furnace installed, the heating element will be positioned so that the coil loops are at the 12 o'clock position, as shown in figure 6-3.

6.3.1.6.3 Furnace Control System

The furnace control system will be capable of controlling the radiant heat output at the required level of $2.5 \pm 0.05 \text{ W/cm}^2$ ($2.2 \pm 0.04 \text{ Btu/ft}^2/\text{second}$), as measured by the heat flux density gauge, under steady-state conditions with the chamber door closed for at least 5 minutes. The control system will consist of an AC solid-state voltage or power controller and a voltmeter or other means for monitoring the electrical input.

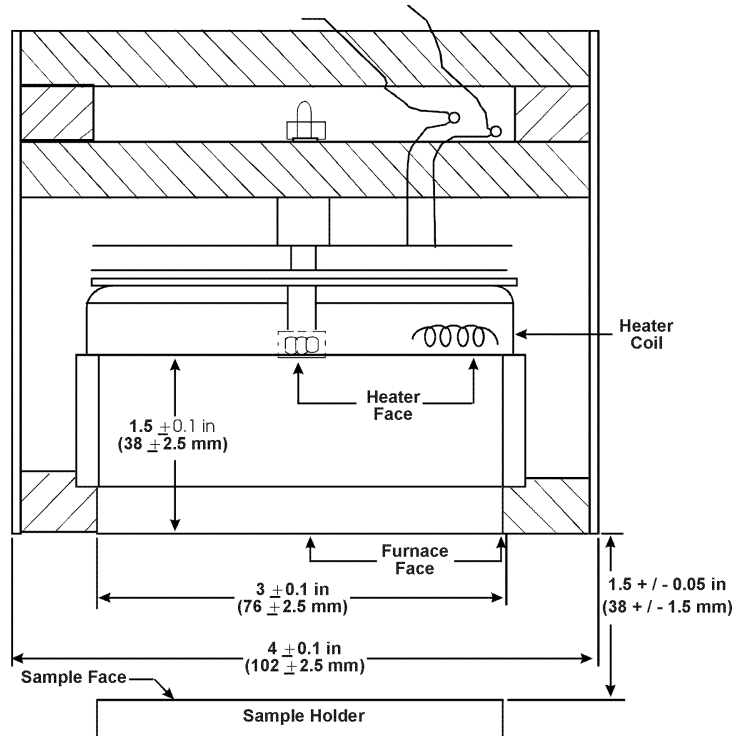

Figure 6-2. Furnace Section

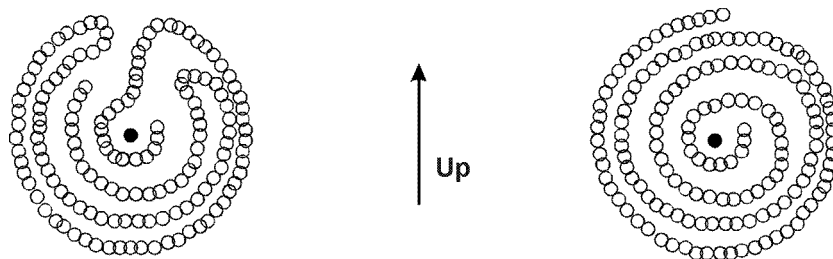

Figure 6-3. Heater Orientation

6.3.1.6.4 Heat Flux Density Gauge

An air-cooled heat flux density gauge will be provided for calibrating the output of the radiant heat furnace. The heat flux density gauge will be a circular foil type, the operation of which was described by Gardon.

6.3.1.6.4.1 Compressed air at a pressure of 15 to 30 psi (0.1 to 0.21 MPa) will be provided to cool the heat flux density gauge. The body temperature of the heat flux density gauge will be monitored with a thermometer having an accuracy of 2°F (1°C) at 200°F (93°C) in a 0.5- by 0.5- by 1.5-inch (13- by 13- by 38-mm) -long brass or copper well drilled to accept the thermometer with a close fit. Silicone grease will be used to provide good thermal contact. The circular receiving surface of the heat flux density gauge will be spray-coated with an infrared-absorbing black paint. The heat flux density gauge will be calibrated calorimetrically using a procedure that is acceptable to the FAA Administrator.

6.3.1.7 Pilot Burner

The pilot burner will be a multiple flamelet type with six tubes, as shown in figure 6-4. The six tubes will be fabricated from stainless steel tubing having an outer diameter of 0.125 inch (3.2 mm) and an inner diameter of 0.055 inch (1.4 mm) \pm 0.001 inch (0.025 mm). The six tubes will be attached to a common manifold, as shown in figure 6-4, fabricated from stainless steel tubing having an outer diameter of 0.25 inch (6.4 mm) and a wall thickness of 0.035 inch (0.9 mm). One end of the manifold will be closed and the other end will be attached to a gas supply fitting on the chamber floor.

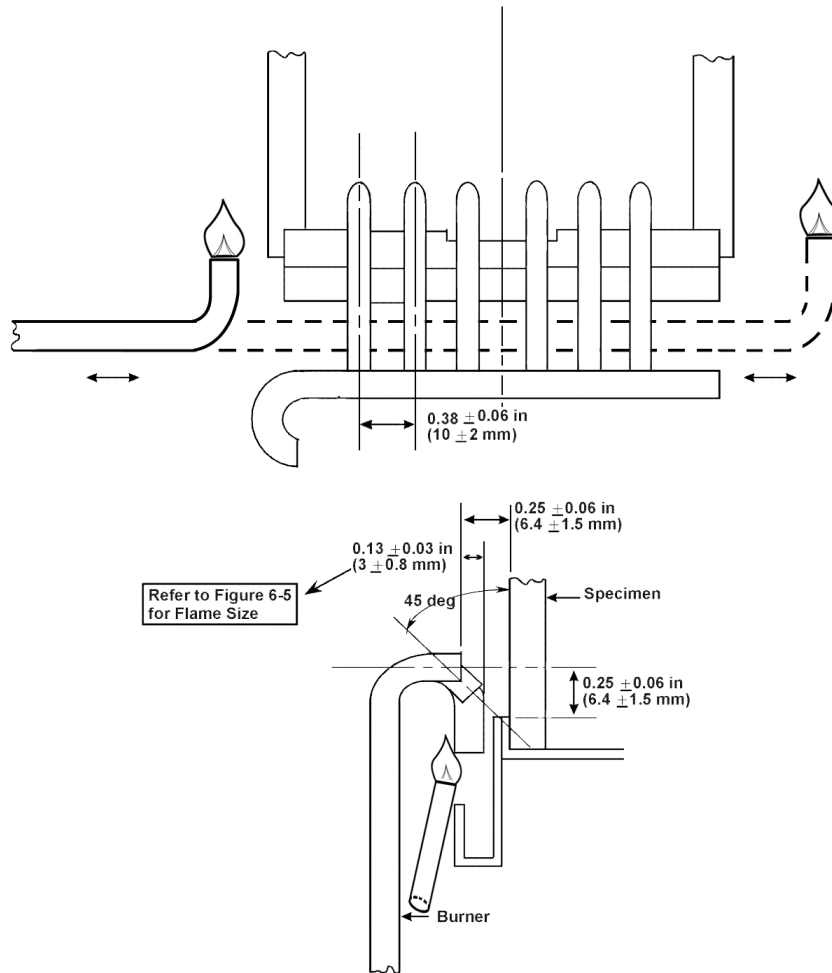

Figure 6-4. Alignment of Holder and Burner

- 6.3.1.7.1 The two outer tubes of the pilot burner will be directed perpendicular to the surface of the specimen. The two inner tubes will be directed at an angle of 45 degrees downward. The two intermediate tubes will be directed vertically downward into the drip pan of the specimen holder.
- 6.3.1.7.2 The pilot burner will be centered in front of and parallel to the specimen holder. The tips of the two outer tubes will be placed 0.25 ± 0.06 inch (6.4 ± 1.6 mm) above the lower opening of the specimen holder and 0.25 ± 0.03 inch (6.4 ± 0.8 mm) away from the face of the specimen surface.

6.3.1.8 Pilot Burner Fuel

The gas fuel for the pilot burner will be prepared by mixing filtered oil-free air with 95 percent minimum purity propane. This mixture will then be fed to the pilot burner. Each gas will be metered through separate, calibrated flowmeters and needle valves. The air-propane mixture will consist of an air flow rate equivalent to 0.018 ± 0.001 ft³/min (500 ± 20 cm³/min) at standard temperature and pressure (STP) and a propane flow rate equivalent to 0.0018 ± 0.0001 ft³/min (50 ± 3 cm³/min) at STP. The compressed air supply will be fed to its flowmeter at 20 ± 5 psi (0.14 ± 0.03 MPa) and the propane at 15 ± 3 psi (0.1 ± 0.02 MPa).

- 6.3.1.8.1 The visible parts of the pilot burner flamelets should be approximately 0.25 inch (6 mm) long with a luminous inner cone approximately 0.13 inch (3 mm) long, as shown in figure 6-5. If the flamelets are not that approximate size, there is probably a difficulty with the air/propane fuel mixture and/or flow rate(s), in which case the accuracy of the flowmeters should be checked.

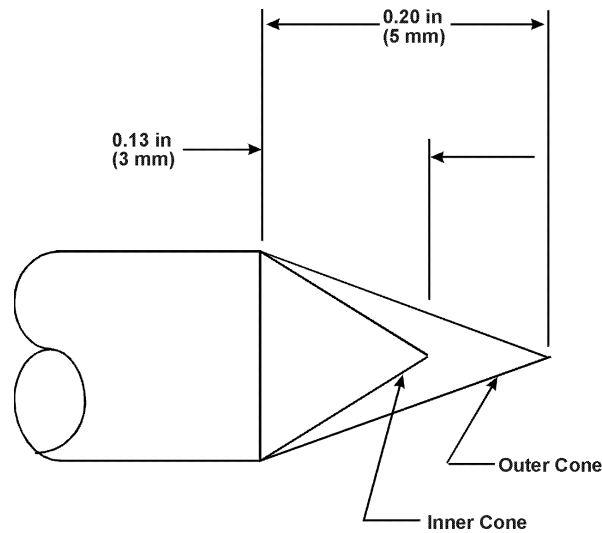

Figure 6-5. Flame Size

6.3.1.9 Specimen Holder

The specimen holder will consist of a stainless steel frame, a backing made of insulation millboard, a spring and retaining rod to secure the specimen in place, and aluminum foil for wrapping the specimen.

6.3.1.9.1 Specimen Holder Frame

The specimen holder frame will be fabricated of stainless steel sheet by bending and brazing (or spot welding) stainless steel sheet of 0.025 ± 0.002 inch (0.64 ± 0.05 mm) nominal thickness to conform in shape and dimension to figure 6-6. The frame will be at least 1.5 inches (38 mm) deep and will provide an exposed specimen surface that is nominally 2.56 by 2.56 inches (65 by 65 mm) and that is at least 6.5 inches² (4,194 mm²) in area.

- 6.3.1.9.1.1 A drip pan to catch and retain dripping material will be attached to the bottom front of the holder.

- 6.3.1.9.1.2 Guides to permit accurate alignment of the exposed specimen area in front of the furnace opening will be attached to the top and bottom of the holder frame.

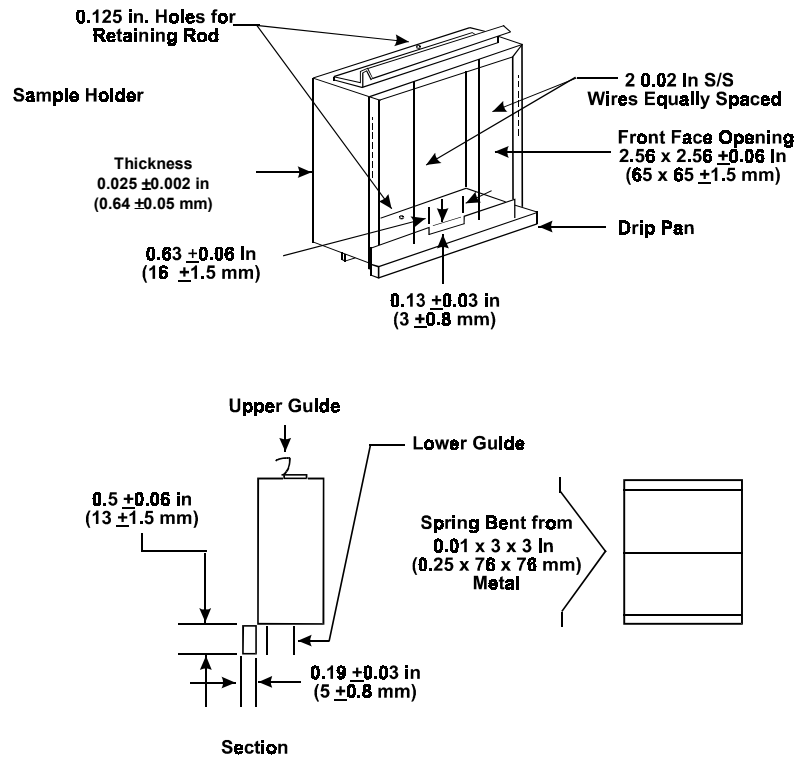

Figure 6-6. Details of Specimen Holder

6.3.1.9.1.3 Two wires made of 0.02 ± 0.005 -inch (0.5 ± 0.12 -mm) diameter stainless steel, vertically oriented and evenly spaced (0.85 inch from the edge of the holder's vertical face openings and 0.85 inch from each other), will be attached to the holder face.

6.3.1.9.2 Specimen Backing

A piece of insulation millboard will be used as a backing for the specimen and as a simulated blank specimen. The millboard will be nominally 0.5 inch (13 mm) thick with a density of 50 ± 10 lb/ft³ (0.8 ± 0.16 g/cm³), or equivalent. Pieces will be cut 2.91 ± 0.03 inches by 2.91 ± 0.03 inches (74 ± 1 mm by 74 ± 1 mm) to fit inside the specimen holder.

6.3.1.9.3 Retaining Spring

A spring bent from a 3- (76-mm) by 2.94- (75-mm) by 0.01-inch (0.25-mm) -thick stainless steel sheet will be used with a stainless steel retaining rod to securely hold the specimen and millboard backing in position during testing.

6.3.1.9.4 Aluminum Foil

Smooth aluminum foil that is 0.0012 ± 0.0005 inch (0.03 ± 0.01 mm) thick will be used to wrap test specimens prior to their insertion in the holder.

6.3.1.10 Support for Radiant Heat Furnace and Specimen Holder

A typical support frame to support the radiant heat furnace and specimen holder is shown in figure 6-7. This support frame will have a provision to establish accurate alignment for the furnace opening so that it is 1.5 ± 0.031 inches (38 ± 1 mm) away from, parallel to, and centered with the exposed specimen surface. Adjustment screws will be provided to align the furnace with reference to the specimen.

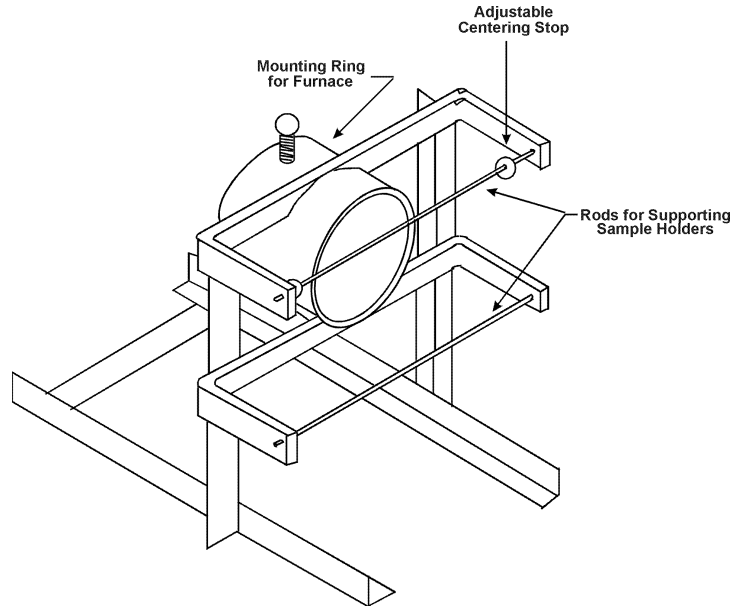

Figure 6-7. Typical Furnace Support

The framework will have two 0.38-inch (10-mm) -diameter transverse rods of stainless steel to accept the guides of the specimen holder. The rods will support the holder so that the exposed specimen surface is parallel to the furnace opening. Spacing stops will be mounted at both ends of each rod to permit rapid and accurate lateral positioning of the specimen holder. An externally operated control rod will be provided to replace the test specimen with the blank specimen holder in front of the furnace.

6.3.1.11 Photometric System

A photometric system capable of detecting light transmittance values of 1 percent minimum to an accuracy of 0.03 percent will be provided. The system will consist of a light source and photomultiplier tube that are oriented vertically to reduce measurement variations due to stratification of the smoke in the chamber during the test, a photomultiplier microphotometer that converts the photomultiplier tube output either to relative intensity and/or to optical density, and a strip chart recorder or other suitable means to record light transmission versus time. A typical system is shown in figures 6-8 and 6-9.

6.3.1.11.1 Light Source

The light source will be an incandescent lamp mounted in a sealed, lighttight box below the chamber floor, operated at a light brightness temperature of $2200 \pm 100\text{K}$ controlled by a constant-voltage transformer. The box will contain the necessary optics to produce a collimated light beam 1.5 ± 0.13 inches (38 ± 3 mm) in diameter, passing vertically up through the chamber. The light source and its optics will be isolated from the chamber atmosphere by a glass window that is mounted flush with the chamber bottom panel and sealed to prevent leakage of chamber contents. To minimize smoke condensation, the window will be provided with a ring-type electric heater mounted in the lighttight box, out of the light path, that maintains a minimum window temperature of 125°F (52°C) on the surface of the window inside the chamber.

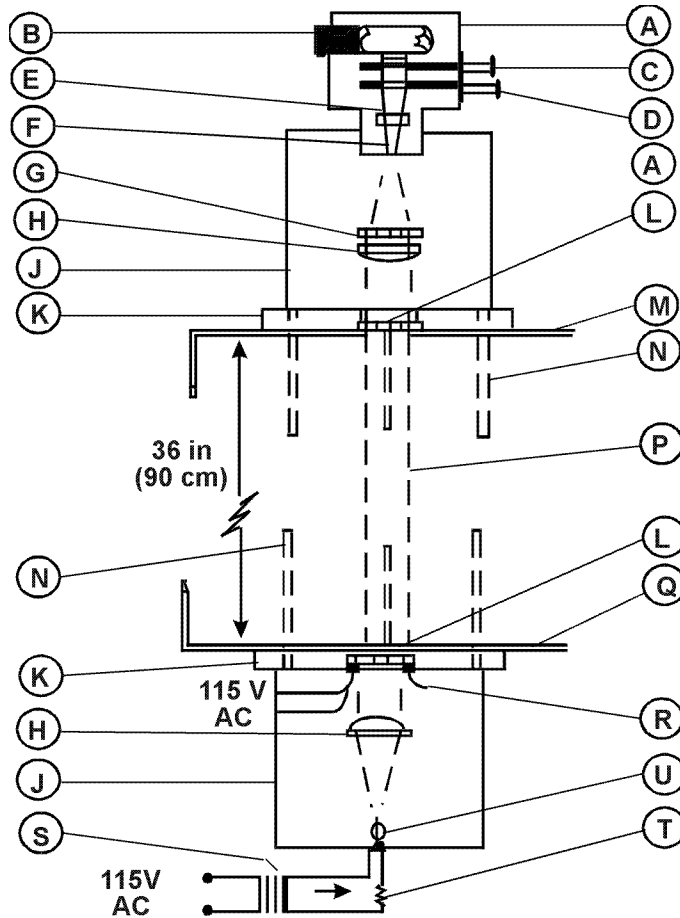

- A - Photomultiplier Housing
- B - Photomultiplier Tube and Socket
- C - Upper Shutter Blade with ND2 Filter over One Aperture
- D - Lower Shutter Blade with Single Aperture
- E - Opal Diffuser Filter
- F - Aperture Disk
- G - Neutral Density Compensating (from set of 9)
- H - Lens 7 Diopter (2)
- J - Optical System Housing (2)
- K - Optical System Platform (2)
- L - Optical Windows
- M - Chamber Roof
- N - Alignment Rods (2)
- P - Parallel Light Beam 1.5 in (37.5 mm) Diameter
- Q - Chamber Floor
- R - Optical Window Heater, Silicone
- S - Regulated Light Source Transformer, 115/125 V-6 V
- T - Adjustable Resistor, Light Source Adjusted for 4V
- U - Light Source

Figure 6-8. Photometer Detail

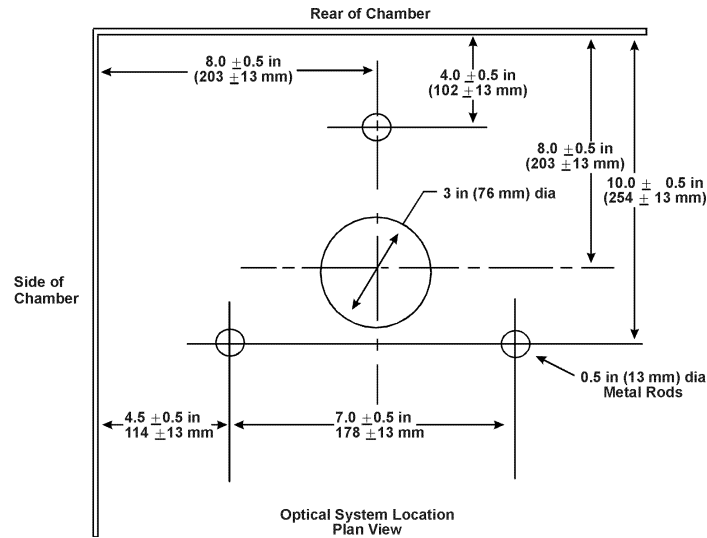

Figure 6-9. Photometer Location

6.3.1.11.2 Photomultiplier Tube

The photomultiplier tube will have an S-4 linear spectral response and a dark current less than 10^{-9} ampere.

6.3.1.11.2.1 The photomultiplier tube and associated optics will be mounted in a second lighttight box that is located above the chamber ceiling directly opposite the light source. The photomultiplier tube and its optics will be isolated from the chamber atmosphere by a glass window that is mounted flush with the chamber ceiling panel. The window, which permits viewing a cross section of 1.5 ± 0.13 inches (38 ± 3 mm), will be sealed to prevent leakage of chamber contents.

6.3.1.11.3 Microphotometer

The microphotometer will be capable of converting the signal from the photomultiplier tube to relative intensity and/or to optical density. The microphotometer/photomultiplier tube combination will be sensitive enough that the microphotometer can be adjusted to produce a full-scale reading (100 percent relative light intensity or optical density = 1) using the photomultiplier tube's response (output) to the light source when a filter of 0.5 or greater optical density is placed in the light path.

6.3.1.11.4 Alignment Fixture

The two optical windows and their housings will be kept in alignment and spaced 36 ± 0.125 inches (914 ± 3 mm) apart with an alignment fixture consisting of three metal rods 0.5 - 0.75 inch (13 - 19 mm) in diameter fastened securely to 0.31-inch (8-mm) -thick externally mounted top and bottom plates and symmetrically arranged about the collimated light beam.

6.3.1.11.5 Optical Filters

A set of nine neutral color optical filters of 0.1, 0.2, 0.3, 0.4, 0.5, 0.6, 0.7, 0.8, and 0.9 optical density will also be provided. The optical filters, one or more as required, may be mounted in the light path in the optical measuring system to compensate for the sensitivity of the photomultiplier tube. These filters may also be used to adjust the photometric system as the light source and/or

photomultiplier tube change sensitivity through aging and/or as discoloration or deterioration of the optical windows occurs.

6.3.1.11.6 Recorder

A recording device will be furnished that provides a record of the percent light transmission and/or optical density versus time during the test. The record will consist either of a continuous curve on a chart recorder or discrete values taken at least every 5 seconds with a computerized data acquisition system.

6.3.1.12 Exhaust Hood

A method for removing the chamber contents after each test will be provided. A fitting for removing the chamber contents may be connected to a suitable exhaust hood. Locating an exhaust hood directly above the smoke chamber door is recommended as an additional safety device.

6.3.1.13 Conditioning Chamber

A conditioning chamber capable of maintaining test specimens at a temperature of $70^{\circ} \pm 5^{\circ}\text{F}$ ($21^{\circ} \pm 3^{\circ}\text{C}$) and $50\% \pm 5\%$ relative humidity will be provided.

6.4 Test Specimen Selection and Preparation

6.4.1 Specimen Number

A minimum of three specimens will be prepared and tested for each part/construction.

6.4.2 Specimen Selection

Specimens will either be taken from an actual part or built to simulate a part.

6.4.2.1 Flat sections of the same thickness and composition may be tested in place of curved, molded, or specialty parts.

6.4.2.2 Both faces of a multilayer assembly will be tested as a separate part/construction if the outer materials are different on the faces and if both sides are exposed to the passenger cabin interior. If both faces must be tested, two sets of specimens will be provided.

6.4.3 Specimen Size

Each specimen will be 2.9 ± 0.06 by 2.9 ± 0.06 inches (73 ± 2 by 73 ± 2 mm). The specimens will be the same thickness as the thickness of the part/construction.

6.4.4 Specimen Orientation

For materials that may have anisotropic flammability properties (i.e., different properties in different directions, such as machine and cross-machine directions for extrusions, warp and fill directions of a woven fabric, etc.), specimens will be tested in the orientation thought to give the highest result. If the average 4D_m is greater than 180, a second set of specimens will be prepared and tested in the orientation that is perpendicular to the orientation used for the first set of specimens. The higher of the two average 4D_m values will be reported.

6.4.5 Specimen Preparation

All surfaces of the specimen, except the surface to be exposed for the test, will be wrapped with aluminum foil (see section 6.3.1.9.4) prior to placing them in a specimen holder. The side of the foil with dull finish will be placed next to the specimen. After the specimen is placed in a specimen holder, any aluminum foil on the exposed specimen will be removed from the bottom (to avoid interference with the pilot burner flamelets) and either removed or folded back on the other three sides (to avoid covering any of the exposed specimen surface area). The specimen will be placed in a holder, followed by an alumina-silica backing board, the spring plate, and the retaining rod (see figure 6-6).

6.5 Specimen Conditioning

- 6.5.1 Specimens will be conditioned at a temperature of $70^{\circ} \pm 5^{\circ}\text{F}$ ($21^{\circ} \pm 3^{\circ}\text{C}$) and $50\% \pm 5\%$ relative humidity for a minimum of 24 hours unless otherwise specified. Only one specimen at a time will be removed from the conditioning chamber. When removed, the specimen will be immediately tested.

6.6 Test Chamber Calibration

6.6.1 Furnace Protection

Prepare a blank specimen consisting of 0.5-inch-thick alumina-silica millboard (see section 6.3.1.9.2) mounted in a specimen holder. To reduce problems with the stability of the heat flux density from the furnace, maintain the blank specimen in front of the furnace when no testing or calibration is being conducted.

6.6.2 Periodic Calibration Procedure

Conduct a periodic calibration of the system as follows.

6.6.2.1 Photometric System

The photometric system used in this test method is an inherently linear device. Check the system for proper photocell alignment. Verify, at least every 2 months, the linearity of the system using a set of neutral optical density filters or equivalent. If erratic behavior is observed or suspected, check the system more frequently.

6.6.2.2 Furnace

Use the approved heat flux density gauge to monitor the heat flux density produced by the furnace. Place the heat flux density gauge on the horizontal rods of the furnace support framework and accurately position it in front of the furnace opening by sliding and displacing the blank specimen holder against the spacing stop (see section 6.3.1.10). With the chamber door closed and the inlet vent opened, adjust the compressed air supply to the heat flux density gauge cooler to maintain its body temperature at $200^{\circ} \pm 50^{\circ}\text{F}$ ($93^{\circ} \pm 3^{\circ}\text{C}$). Adjust the setting of the furnace control voltage or power controller to obtain the calibrated millivolt output of the heat flux density gauge corresponding to a steady-state irradiance of $2.5 \pm 0.05 \text{ W/cm}^2$ ($2.2 \pm 0.04 \text{ Btu/ft}^2/\text{second}$). After the irradiance has reached the required value and has remained steady-state for at least 5 minutes, remove the heat flux density gauge from the chamber and replace it with the blank specimen holder.

- 6.6.2.2.1 Record the setting of the furnace control voltage or power controller and use this setting until a future calibration indicates it should be changed.

6.6.2.3 Chamber Leak Test

Test the smoke density chamber leak rate at least once a month, or more often if loss of chamber pressure is suspected, using the following procedure.

- 6.6.2.3.1 Close the inlet vent and the chamber door.

- 6.6.2.3.2 Pressurize (e.g., by bleeding in a small amount of air through the port used for the heat flux density gauge) the chamber to at least 3 inches of water above ambient as indicated by the manometer.

- 6.6.2.3.3 Note the chamber pressure. Verify that the chamber pressure leakage rate is less than 2 inches of water in 2 minutes.

6.6.2.4 Total System

Check the total system at least once a month by testing a material that has shown a consistent specimen-to-specimen 4D_m value in the range of 150 to 220 4D_m and that is, and will continue

to be, readily available. Maintain a record of the test results obtained. If erratic values are observed, identify and correct any instrumental or operational deficiencies.

6.6.3 Chamber Cleaning

Clean the optical system windows, viewing window, chamber walls, and specimen holders as follows.

6.6.3.1 Optical System Windows

Clean the exposed surfaces of the glass separating the photo detector and light source housings from the interior of the chamber after each test. Clean the top window first, then the bottom window, using a nonabrasive cloth dampened with a suitable cleaner. Dry the window to prevent streaking or film buildup. Do not use any cleaners that contain wax because wax will cause the smoke to adsorb to the glass more quickly.

6.6.3.2 Viewing Window

Clean the viewing window periodically as required to allow viewing the chamber interior during testing. The same cleaners used in section 6.6.3.1 have been found satisfactory.

6.6.3.3 Chamber Walls

Clean the chamber walls periodically to prevent excessive build-up of smoke products. An ammoniated spray detergent and nonabrasive scouring pad have been found effective.

6.6.3.4 Specimen Holders

Remove any charred residue on the specimen holders and horizontal rods securing the holder position to prevent contamination of subsequent specimens.

6.7 Test Procedure

6.7.1 Each day, prior to testing, adjust the chamber as follows.

6.7.1.1 Calibrate the furnace output according to section 6.6.2.2 to determine the correct furnace voltage.

6.7.1.2 Balance the photomultiplier dark current and set the clear beam reading to 100 percent relative transmission or to optical density 0.00.

6.7.1.3 Set the photomultiplier scale at 100. Shut the lower shutter blade (D) directly below photomultiplier tube (B) (see figure 6-8). Set zero on the data recording device.

6.7.2 Conduct the test procedure as follows.

6.7.2.1 Ensure that the specimen(s) have been properly prepared per sections 6.4.1 through 6.4.5.

6.7.2.2 Ensure that the chamber wall temperature is $95^{\circ} \pm 4^{\circ}\text{F}$ ($35^{\circ} \pm 2^{\circ}\text{C}$).

6.7.2.3 Ensure that the furnace voltage has been set correctly.

6.7.2.4 Set the clear beam reading to 100 percent relative transmission or to optical density 0.00. See section 6.7.1.2.

6.7.2.5 Position the pilot burner in front of and parallel to the specimen holder. Turn on the pilot burner fuel (see section 6.3.1.8) and light the flamelets on the pilot burner. Make sure all flamelets are ignited and properly adjusted.

6.7.2.6 Remove a test specimen from the conditioning chamber, open the test chamber door, and place the specimen holder on the support. Immediately push the specimen holder into position in front of the furnace, displacing the blank specimen holder to the prepositioned stop, and close the chamber door and inlet vent. For chambers with an external device to move the specimen holder in front of the furnace, place the holder on the support, close the

door, slide the sample into position, and simultaneously start the timer and recorder for light transmission.

- 6.7.2.7 Continue the test for a minimum of 4 minutes (240 seconds). Do not perform any analysis of the chamber contents, such as gas sampling, during the first 4 minutes (240 seconds) of testing.
- 6.7.2.8 Record the percent light transmission and/or optical density versus time (minutes) during the test.
- 6.7.2.9 Monitor the chamber pressure during the test. If negative pressure (below ambient atmospheric) develops, open the inlet valve slightly to relieve negative pressure.
- 6.7.2.10 Monitor the pilot burner flamelets during the test. Note and record if either of the outer flamelets oriented perpendicular to the specimen surface or if either of the inner flamelets oriented 45 degrees to the specimen surface extinguishes and remains continuously extinguished for more than 3 seconds. If such extinguishing occurs, the test results from that specimen are not valid, and the test may be terminated and another test started with a new test specimen.
- 6.7.2.11 At the termination of the test, remove the test specimen holder from its position in front of the furnace and replace it with the blank specimen holder using the exterior control rod. Begin exhausting the chamber of smoke within 1 minute by opening the door and the inlet vent (and exhaust vent, if used).
 - 6.7.2.11.1 Continue to exhaust the chamber until all smoke has been removed.
- 6.7.2.12 Clean the windows to the housings for the photomultiplier tube and the light source per section 6.6.3.1.
- 6.7.2.13 Calculate and record the maximum specific optical density, 4D_m , during the 4-minute (240-second) test for each specimen according to the formula:

$$\begin{aligned} {}^4D_m &= (V / LA) \log_{10}(100/{}^4T_m) \\ &= 132 \log_{10}(100/{}^4T_m) \end{aligned}$$

where:

- V = chamber volume = 18.00 ft³ (0.510 m³)
- L = light path length = 3.00 ft (0.914 m)
- A = exposed specimen area = 6.57 in² (0.00424 m²)
- 4T = minimum percent light transmission during 4 minutes

$\log_{10}(100/{}^4T_m)$ = maximum optical density during 4 minutes

- 6.7.2.14 Calculate and record the average 4D_m value and its standard deviation for all the specimens tested for each part/construction. Use the actual 4D_m values for this average; do not use the average light transmission value to determine the average 4D_m value.

6.8 Report

- 6.8.1 Report a complete identification of the part/construction tested, such as material construction, thickness, weight, etc.
- 6.8.2 Report the number of specimens tested and the average 4D_m .
- 6.8.3 Report any additional data or observations as applicable and/or required by the test plan.

6.9 Requirements

- 6.9.1 Through FAR 25.853(c-1) Amendment 25-72, the average 4D_m during the 4-minute test will not exceed 200.

Chapter 6 Supplement

This supplement contains advisory material pertinent to referenced paragraphs.

6.2.1 In most cases, the maximum specific optical density (4D_m) should be at 4 minutes; however, due to coagulation of smoke particles, or to adsorption of smoke particles to the walls of the chamber, it is possible for the maximum to occur earlier in the test.

6.3.1 Recommended Equipment

The following items are recommended but not required:

- Digital Voltmeter—Preferred to monitor furnace voltage and heat flux density gauge output. A Keithley Model 165 Autoranging Multimeter or equivalent has been found acceptable.
- Constant Voltage Transformer—A constant voltage transformer is recommended for all installations (see section 6.3.1.5).
- Pilot Burner Positioning Fixture—A fixture to accurately position the pilot burner is recommended to establish a precise pilot burner position for testing and to facilitate accurate repositioning of pilot burner after removal and replacement (see figure 6-10).

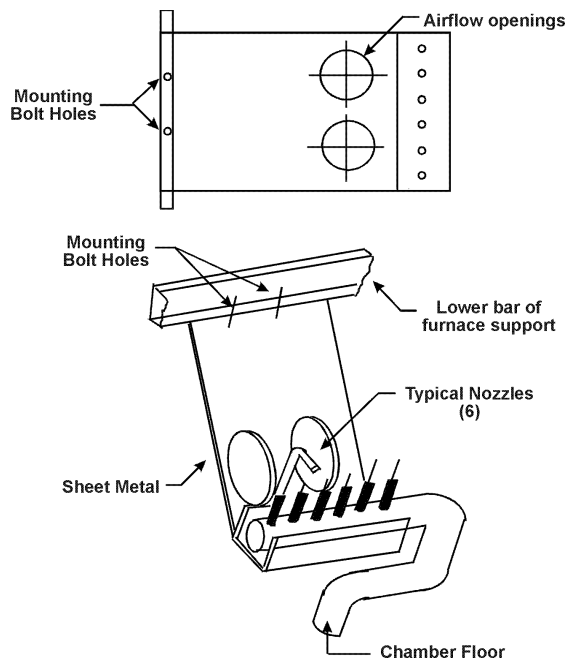

Figure 6-10. Burner Position (Optional)

A more precise positioning device is available from Newport Scientific. Its part number is 680860354000.

- Reignition System—A reignition system is recommended to relight the horizontal and 45-degree pilot burner flamelets to ensure that none of them extinguishes for more than 3 seconds during the test. The preferred method of reignition is a manually operated sliding tube, with a propane and air mix, adjusted to impinge on the pilot outlets as it is moved across an area adjacent to the pilot flames. A method of operating this could be made similar to the device in the smoke chamber that moves the sample, i.e., push-pull rod (see figure 6-4). If an electric sparking device is used, an appropriate method of suppression and equipment shielding must be applied to have no interference with the ability of the data acquisition equipment to accurately record data.

6.3.1.1 Commercially available panels of porcelain-enameled steel (interior surface) permanently laminated to a magnesia insulation core and backed with galvanized steel (exterior surface) have been found acceptable.

A thin sheet of transparent material may be placed over optical and viewing windows to protect them from corrosive components in the smoke.

6.3.1.3 Venting the water-filled pressure regulator to a suitable exhaust system is necessary to prevent the buildup of unknown contaminants in the laboratory area. The location of the pressure relief tube should be on or within 6 inches of the top of the chamber.

6.3.1.5 A powerstat variable autotransformer, Type 21, from Superior Electric Co., Bristol, Connecticut, or equivalent has been found satisfactory to transform electric power to that required by the chamber.

A constant voltage transformer from Sola Electric Co., Chicago, Illinois, Catalog Number 23-13-150, or equivalent, has been found satisfactory. A Sorenson Model 200S AC voltage regulator, or equivalent, has been found satisfactory.

6.3.1.6 Furnace model P/N 6806025700 from Newport Scientific has been found acceptable.

Furnace model P/N 680860380000 from Newport Scientific has also been found acceptable. A calibration device, P/N 4-5808, is also available from Newport Scientific.

6.3.1.6.3 A model 470 Series power controller manufactured by Eurotherm and a Model 3AEV1B10C1 Triac manufactured by General Electric Company, or equivalent, have been found satisfactory.

The furnace control system should be a reputable unit that provides the parameters to fulfill the requirements of the furnace.

It is recommended to use a digital voltmeter to monitor the furnace voltage output and a digital amperemeter to monitor the furnace current.

6.3.1.6.4 Gardon, R., "An Instrument for the Direct Measurement of Intense Thermal Radiation," *Review of Scientific Instruments*, Vol. 24, 1953, pp. 360-370.

A thermocouple system capable of measuring $200^{\circ} \pm 2^{\circ}\text{F}$ is an acceptable alternate method to monitor the body temperature of the heat flux density gauge.

6.3.1.7 The pilot burner should be aligned with a sample holder and backing board in place. A description of a suitable method of alignment is shown in figure 6-4. Care should be taken to ensure accurate positioning of the pilot tips to the sample holder.

6.3.1.8 Commercially bottled propane has been found acceptable.

6.3.1.9.1 Mounting the wire through holes made in the drip pan attachment mount between the top of the drip pan and the bottom of the holder across the face of the specimen and over the top of the holder, and through holes made in the flange of the top guide just above the top of the holder has been found satisfactory. This scheme permits the use of only one piece of wire threaded through the four holes with the two ends twisted together behind the guide at the top of the holder.

Sample holders must be checked for accuracy with each other; for example, top and bottom mounting devices consistent with each other. It has been noted that misalignment between holders does result in pilot position errors.

6.3.1.9.2 A recommended material is Marinite I.

6.3.1.9.4 Aluminum foil used for household food wrapping is acceptable.

6.3.1.11.2 A thin sheet of transparent material may be placed over optical and viewing windows to protect them from corrosive components in the smoke.

6.4.1 Conditions may require as many as six specimens. For test purposes, specimens should be marked with an arrow for a consistent direction by manufacturers or operators.

6.6.3.1 Ethyl alcohol, methyl ethyl ketone, or equivalent has been found satisfactory.

6.7.1.2 This procedure is described in AMINCO NBS Smoke Density Chamber, Catalog No. 4-5800B, Instruction 941B.

6.7.1.3 During testing at the FAA William J. Hughes Technical Center, a problem was discovered with the calculation of D_s during some NBS chamber testing. The problem is software related. It is possible that during the initial readings taken with a blanked off photocell there should be some residual voltage reading (± 1 millivolt). This is too small a value to be read visually but can be detected by the computer. The problem is that current software assumes the initial value is zero and the results are altered accordingly. Because the specific optical density is a logarithmic function, the problem is magnified by the higher the value, making the D_s around the pass/fail point of 200 critical. A \pm millivolt initial reading can change an actual D_s of 200 to 175/224, respectively. The fix for this problem is to blank off the photocell prior to each test and let the computer set the "zero."

Computer users could use the following procedure for the computer program: close the shutter, let the computer read baseline volts (0) (mV_b), and determine:

$$\text{Slope} = \frac{100}{(mV_H - mV_b)}$$
$$\%L.T. = (mV - mV_b) * \text{Slope}$$

6.7.2.11 CAUTION: The door should be opened gradually to avoid exposure to the chamber contents, which may be toxic.

Chapter 7 Oil Burner Test for Seat Cushions

7.1 Scope

- 7.1.1 This test method evaluates the burn resistance and weight loss characteristics of aircraft seat cushions when exposed to a high-intensity open flame to show compliance to the requirements of FAR 25.853.

7.2 Definitions

7.2.1 Burn Lengths

The four principal burn lengths are measured along the topside of the horizontal seat cushion, bottomside of the horizontal seat cushion, frontside of the vertical seat cushion, and the backside of the vertical seat cushion. The four burn lengths are defined as the distance measured, in inches, from the edge of the seat frame nearest the burner to the farthest point where damage to the test specimen occurred due to that area's combustion, including partial or complete consumption, charring, or embrittlement but does not include areas sooted, stained, warped, or discolored.

7.2.2 Percent Weight Loss

The percentage weight loss for a specimen set is the pretest weight of the specimen set less the posttest weight of the specimen set expressed as the percentage of the pretest weight. All droppings falling from the specimens and mounting stand are to be discarded prior to determining the posttest weight.

7.2.3 Back Cushion Specimen

The back cushion specimen is the cushion specimen in the vertical orientation. This specimen may be representative of the production seat back, seat bottom, or both if the production articles have the same construction.

7.2.4 Bottom Cushion Specimen

The bottom cushion specimen is the cushion specimen in the horizontal orientation. This specimen may be representative of the production seat back, seat bottom, or both if the production articles have the same construction.

7.2.5 Specimen Set

A specimen set consists of one back cushion specimen and one bottom cushion specimen. Both specimens represent the same production cushion construction; that is, both specimens in the specimen set have identical construction and materials proportioned to correspond to either the actual seat bottom or back cushion but not both. For various reasons seat bottom and back cushions on actual seats are typically as installed in the airplane.

7.3 Apparatus

7.3.1 Test Apparatus

The arrangement of the test apparatus is shown in figures 7-1 and 7-2 and includes the components described in this section. The burner stand has the capability of moving the burner away from the test specimen during warmup.

7.3.2 Test Burner

The burner will be a modified gun type, such as Park Model DPL 3400, Lennox Model OB-32, or Carlin Model 200 CRD. Flame characteristics can be enhanced by the optional use of a static disk or tabs. See static disk in the supplement to this chapter. Major deviations, for example a different burner

type, require thorough comparison testing. Temperature and heat flux measurements, as well as test results, must correspond to those produced by an FAA approved burner.

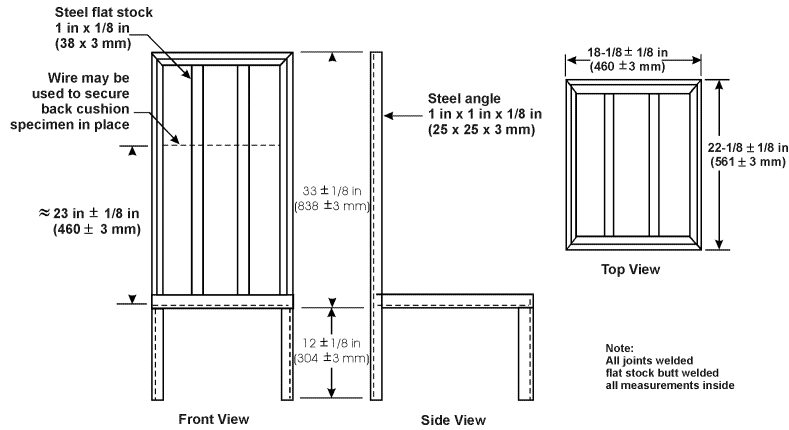

Figure 7-1. Front, Side, and Top Views of Seat Oil Burner Specimen Frame

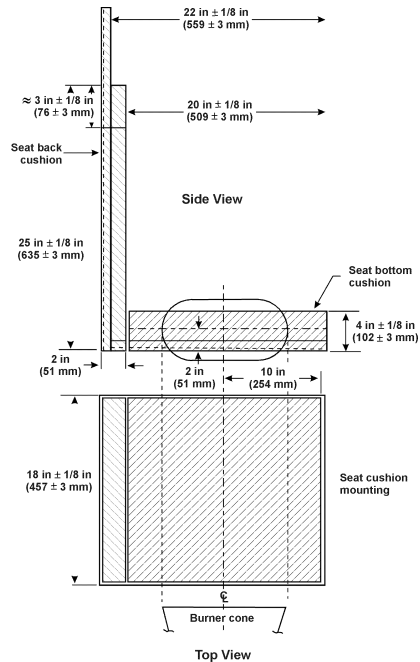

Figure 7-2. Top and Side View of Specimen Setup in Test Frame

7.3.2.1 Nozzle

The nozzle used for the burner is required to maintain a fuel pressure that will yield a 2 ± 0.1 gallons/hour ($0.126 \text{ L/min} \pm 0.0063 \text{ L/min}$) fuel flow.

7.3.2.2 Burner Cone

A $12 \pm 1/8$ -inch (305 ± 3 -mm) burner cone extension will be installed at the end of the draft tube. The cone will be made of stainless steel or a similar type of noncorrosive high-temperature metal and will have a thickness of 0.065 ± 0.015 inch (1.65 ± 0.375 mm). The opening of the cone will be $6 \pm 1/8$ inches (152 ± 6 mm) high and $11 \pm 1/8$ inches (280 ± 6 mm) wide (see cone in figures 7-3a and 7-3b).

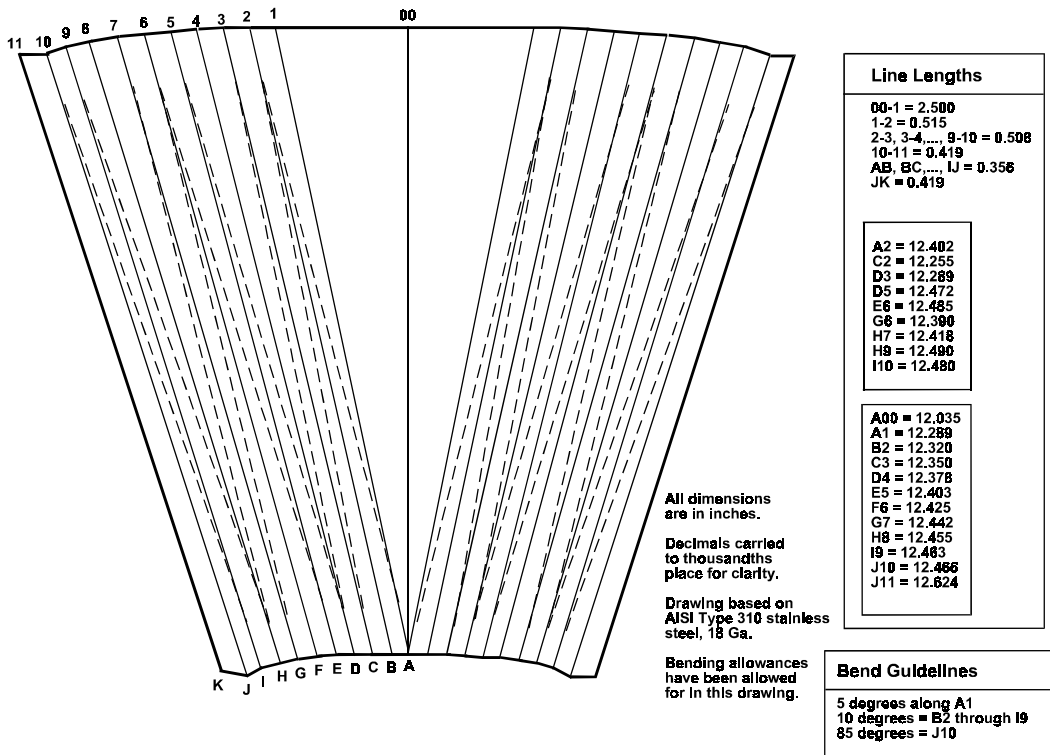

Figure 7-3a. Burner Cone Layout and Bending Pattern

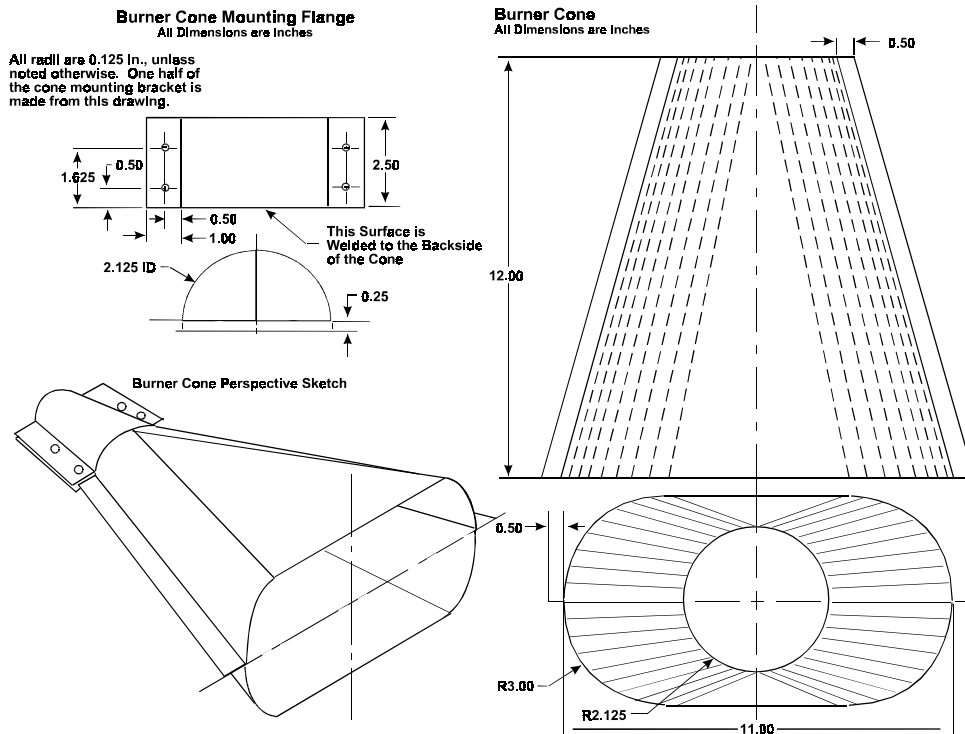

Figure 7-3b. Burner and Cone Details

7.3.2.3 Fuel

ASTM K2 fuel (number 2 grade kerosene) or ASTM D2 fuel (number 2 grade fuel oil) will be used.

7.3.2.4 Fuel Pressure Regulator

A fuel pressure regulator adjusted to deliver 2 gallons/hour \pm 0.1 gallon/hour (7.57 liters/hour \pm 0.038 liter/hour) will be provided.

7.3.2.5 Anemometer

A vane-type air velocity sensing unit will be used to monitor the flow of air at the inlet of the oil burner. The inlet will be completely sealed except for an opening for the air velocity sensor where it will be centered and mounted (see anemometer setup in figure 7-4).

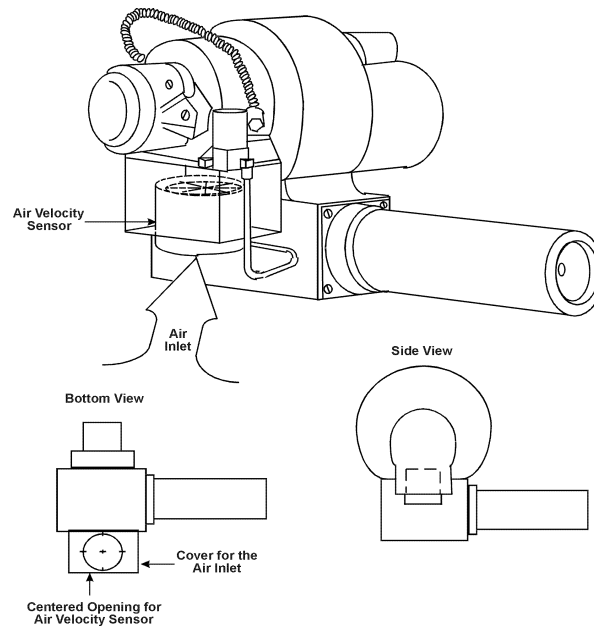

Figure 7-4. Illustration for the Location of the Air Velocity Sensor

7.3.3 Calorimeter

The calorimeter will be a total heat flux, foil type Gardon Gage of an appropriate range such as 0 to 15 Btu/(ft² second) (0 to 17 W/cm²), accurate to \pm 3 percent of the indicated reading.

7.3.3.1 Calorimeter Mounting

The calorimeter will be mounted in a 6 by 12 \pm 1/8-inch (152 by 305 \pm 3-mm) by 3/4-inch (19-mm) -thick insulating block that is attached to a steel angle bracket for placement in the test stand during burner calibration (see figure 7-5). The insulating block will be monitored for deterioration and replaced when necessary. The mounting will be shimmed as necessary to ensure that the calorimeter face is parallel to the exit plane of the test burner cone.

7.3.4 Thermocouples

Seven 1/16-inch-diameter ceramic packed, metal sheathed, type K (Chromelalumel), grounded junction thermocouples with a nominal 30 AWG size conductor will be provided for calibration. The thermocouples will be attached to a steel bracket to form a thermocouple rake for placement in the test stand during burner calibration, as shown in figure 7-6.

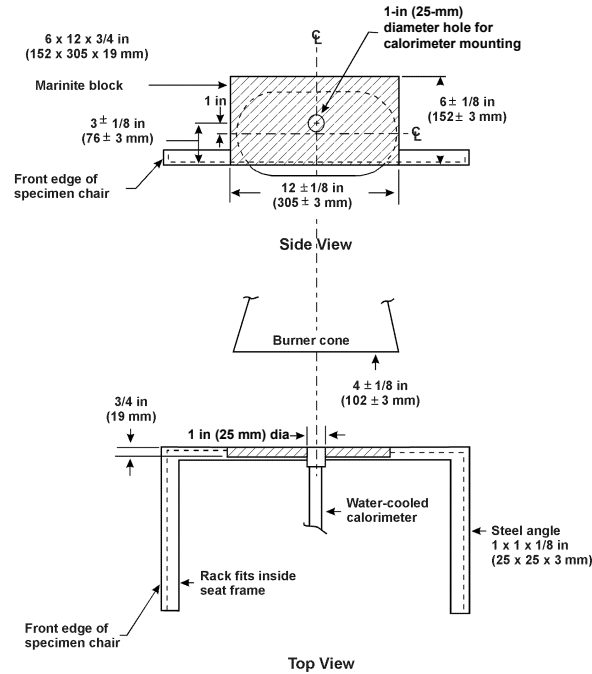

Figure 7-5. Top and Side Views of Calorimeter Bracket

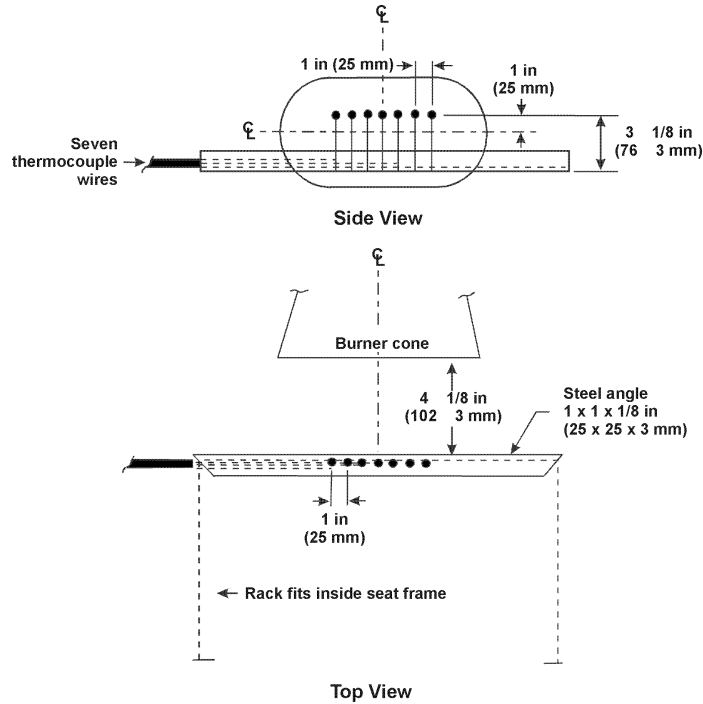

Figure 7-6. Top and Side Views of Thermocouple Rack Bracket

7.3.5 Specimen Mounting Frame

The mounting frame for the test specimen will be fabricated of 1 by 1 by 1/8-inch (25 × 25 × 3-mm) steel angle, as shown in figure 7-1. A wire can be added to the mounting frame for the seat back cushion to secure the specimen into place. The mounting stand will be used for mounting the test specimen seat bottom and seat back, as shown in figure 7-2. Reference paragraph 7.3.5 of Chapter 7 Supplement.

7.3.5.1 Drip Pan

The mounting stand will include a suitable drip pan lined with aluminum foil, dull side up. The drip pan will be located at the bottom of the mounting stand legs, $12 \pm 1/8$ inches (305 ± 3 mm) below the horizontal specimen holder.

7.3.6 Instrumentation

A calibrated recording device or a computerized data acquisition system with an appropriate range will be provided to measure and record the outputs of the calorimeter and the thermocouples.

7.3.7 Weight Scale

A weighing device will be provided to determine the pretest and posttest weights of each set of seat cushion specimens within 0.02 pound (9 g).

7.3.8 Timing Device

A stopwatch or other device, accurate to ± 1 second/hour, will be provided to measure the time of application of the burner flame and self-extinguishing time (or test duration).

7.4 Test Specimens

7.4.1 Specimen Preparation

A minimum of three specimen sets of the same construction and configuration will be prepared for testing.

7.4.2 Seat Bottom (Horizontal) Cushion Specimen

The constructed, finished specimen assembly will be $18 + 0, -1/8$ inches ($457 + 0, -3$ mm) by $20 + 0, -1/8$ inches ($508 + 0, -3$ mm) by $4 + 0, -1/8$ inches ($102 + 0, -3$ mm), exclusive of fabric closures and seam overlap.

7.4.3 Seat Back (Vertical) Cushion Specimen

The constructed, finished specimen assembly will be $18 + 0, -1/8$ inches ($457 + 0, -3$ mm) by $25 + 0, -1/8$ inches ($635 + 0, -3$ mm), by $2 + 0, -1/8$ inches ($51 + 0, -3$ mm), exclusive of fabric closures and seam overlap.

7.4.4 Construction

Each specimen tested will be fabricated using the principal components (i.e., foam core, flotation material, fire-blocking material, if used, and dress covering) and assembly processes (representative seams and closures) intended for use in the production articles. If a different material combination is used for the production back cushion than for the production bottom cushion, both material combinations will be tested as complete specimen sets. Each set will consist of a back cushion specimen and a bottom cushion specimen (see figure 7-7).

7.4.4.1 Fire-Blocking Material

If the cushion is constructed with a fire-blocking material, the fire-blocking material will completely enclose the cushion foam core material.

7.4.4.1.1 Specimen Fire-Blocking Fabrication

The method of fabricating blocking layer seams and closures will be the same as the production method. In fabricating the test specimen, the fire blocker will be configured so that any possible weak point is exposed to the burner flame. This may require configuring a test specimen so that the seam is exposed to the test burner, even though a seam may not be located there on a production cushion.

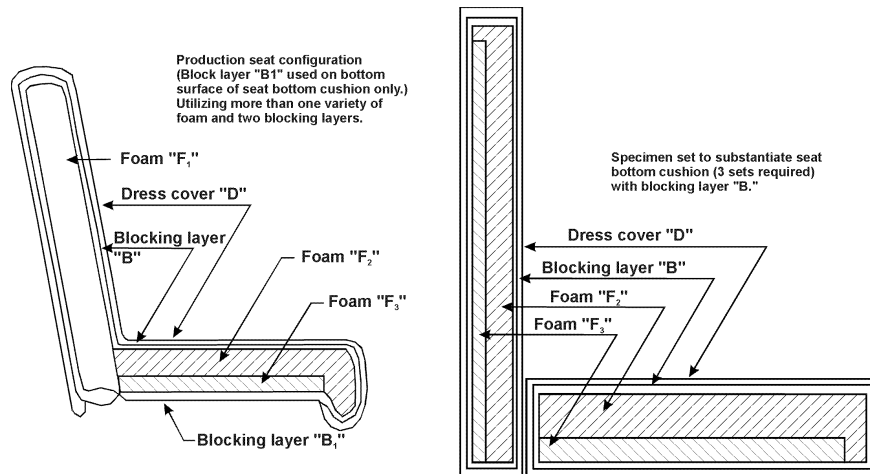

Figure 7-7. Example of Production Seat Configuration and Test Specimen Set to Substantiate Production Seat Bottom Cushion

7.4.4.1.2 Multiple Fire-Blocking Materials

If more than one fire-blocking layer material is used on a given production cushion, each blocking layer material will be subjected to this test procedure as separate test sets with the fire-blocking material completely encapsulating the specimens so that all fire-blocking layers are subjected to the same level of test severity. Fire-blocking layers will not be used in combination for this test (see figure 7-8).

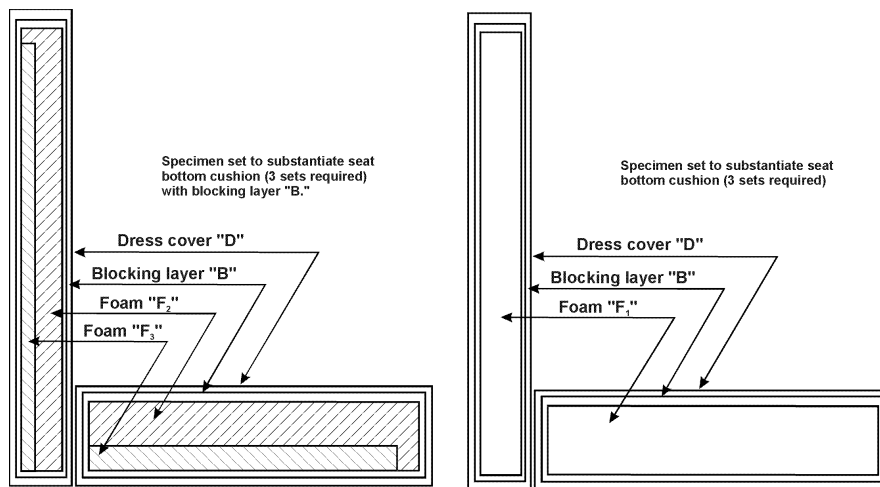

Figure 7-8. Specimen Set to Substantiate Production Seat Bottom and Specimen Set to Substantiate Production Seat Back

7.4.4.2 Foam

Seats that utilize more than one variety of foam (composition, density, etc.) will have specimen sets constructed that reflect the foam combination used.

7.4.4.3 Dress Covering

If a production seat construction utilizes more than one dress covering, the test configuration may be represented as shown in figure 7-9.

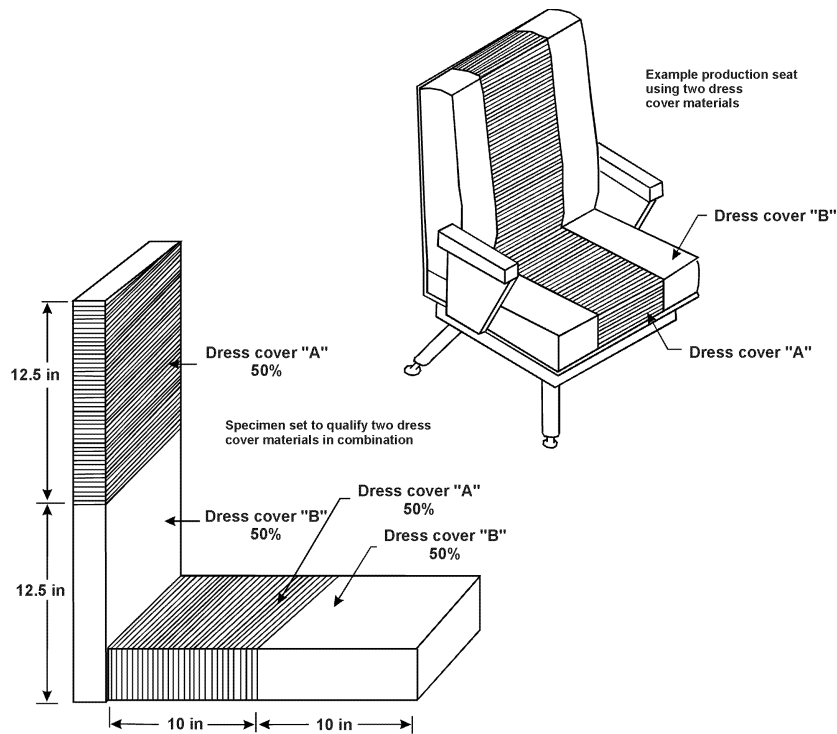

Figure 7-9. Example of Production Seat Configuration Using Two Dress Cover Materials and Test Specimen Set to Substantiate Dress Cover Combination

7.5 Specimen Conditioning

- 7.5.1 The specimens will be conditioned at $70^{\circ} \pm 5^{\circ}\text{F}$ ($21^{\circ} \pm 2^{\circ}\text{C}$) and $55\% \pm 10\%$ relative humidity for a minimum of 24 hours prior to testing.

7.6 Preparation of Apparatus

- 7.6.1 Level and center the frame assembly to ensure alignment of the calorimeter with the burner cone.
- 7.6.2 Turn on the ventilation hood for the test chamber. Do not turn on the burner fan. Measure the airflow in the test chamber using a hot wire anemometer or equivalent measuring device. The vertical air velocity just behind the top surface of the vertical specimen will be 25 ± 10 ft/min (12.7 ± 5.1 cm/second). The horizontal air velocity will be less than 10 ft/min (5.1 cm/second) just above the center of the horizontal seat cushion specimen.
- 7.6.3 The fuel flow rate will be 2.0 ± 0.1 gallon/hour (0.126 ± 0.0063 L/min).
- 7.6.4 The air inlet of the oil burner must be completely sealed, except for an opening where the air monitoring device will be mounted. With the anemometer set up for measuring, turn the motor on and run it for at least 30 seconds to allow the blower to reach its operating speed (it is not necessary for the ignitor and fuel flow to be turned on). Set the airflow to 67 ± 4 ft³/min (1.89 ± 0.11 m³/min) by adjusting the air shutter. (See paragraph 7.3.2.5 of Chapter 7 Supplements, for the airflow conversion formula and an example of airflow conversion based on an airflow of 67 cubic feet per minute.) Once this airflow value is maintained, keep the air shutter in position by tightening the lock screw. This will be the initial airflow setting. Later adjustments, within the specified airflow range, may be necessary to attain the calibration temperatures and heat flux.

7.7 Calibration

- 7.7.1 Secure the calorimeter in the bracket and place it on the test frame assembly used to mount specimens. Position the burner so that the vertical plane of the burner cone exit is centered in front of the test frame assembly at a distance of $4 \pm 1/8$ inches (102 ± 3 mm) from the calorimeter face. Ensure that the horizontal centerline of the calorimeter is offset $1 \pm 1/16$ inch (25.4 ± 1.6 mm) above the horizontal centerline of the burner cone (see figure 7-5).
- 7.7.1.1 Prior to starting the burner, ensure that the calorimeter face is clean of soot deposits and that there is water running through the calorimeter.
- 7.7.2 Rotate the burner from the test position to the warmup position. Examine and clean the burner cone of any evidence of buildup of productions of combustion, soot, etc.
- 7.7.3 While the burner is rotated out of the test position, turn on the fuel and light the burner. Allow it to warmup for 2 minutes. Move the burner into the test position and adjust the air intake and oil burner components to achieve a heat flux of $10 \text{ Btu}/(\text{ft}^2 \text{ second} \pm 0.5 \text{ Btu}/\text{ft}^2/\text{sec})$ ($11.9 \text{ W}/\text{cm}^2 \pm 0.6 \text{ W}/\text{cm}^2$) or greater. Record heat flux density measurements at least once per second averaged over a 30-second time period to ensure a steady-state condition.
- 7.7.4 Replace the calorimeter bracket with the thermocouple rake, ensuring that the distance of each of the seven thermocouples is $4 \pm 1/8$ inches (102 ± 3 mm) from the vertical plane and offset $1 \pm 1/16$ inch (25.4 ± 1.6 mm) above the horizontal centerline of the burner cone exit (see figure 7-6).
- 7.7.5 Start the burner and allow it to warmup for 2 minutes. After warmup, move the burner into position and record the temperature of each thermocouple at least once every second averaged over a 30-second time period. Of the seven thermocouples used, any two will be equal to or greater than 1750°F (954°C), while the remaining thermocouples will each be equal to or greater than 1800°F (982°C). The average of the seven thermocouples must be equal to or greater than 1800°F . After a steady-state condition has been achieved with the required temperatures mentioned above, turn off the burner.
- NOTE: It is advisable to run within reasonable bounds of the heat flux and temperature requirements in sections 7.7.3 and 7.7.5. If the heat flux and temperature are significantly higher, erratic data may occur.
- 7.7.6 If the temperature of each thermocouple is not within the specified range, repeat sections 7.7.1 through 7.7.5 until all parameters are within the calibration.
- 7.7.7 When calibration is attained, tighten the air shutter's lock screw.

7.8 Test Procedure

- 7.8.1 Record the weight of each set of seat bottom and seat back cushion specimens to the nearest 0.02 pound (9 g's) and secure the test specimens to their respective frames. The seat back cushion can be secured at the top with wires. Reference paragraph 7.3.5 of Chapter 7 Supplement for guidance information.
- 7.8.2 Ensure that the vertical plane of the burner cone is at a distance of $4 \pm 1/8$ inches (102 ± 3 mm) from the test specimen and that the horizontal centerline of the burner cone is centered with the bottom cushion, as shown in figure 7-2.
- 7.8.3 When ready to begin the test, direct the burner away from the test position to the warmup position so that the flame will not impinge on the specimen. Turn on and light the burner and allow it to stabilize for 2 minutes.
- 7.8.4 To begin the test, rotate the burner into the test position and start the timing device when the burner is in the final position.
- 7.8.5 Expose the test specimen to the burner flame for 2 minutes and then turn off the burner. Immediately rotate the burner out of the test position.

- 7.8.6 Terminate the test when the specimens self-extinguish. If the specimens do not self-extinguish after 5 minutes from the time the burner had been turned off, terminate the test by extinguishing the test specimens.
- 7.8.7 Immediately after test termination, determine the posttest weight of the remains of the seat cushion specimen set to the nearest 0.02 pound (9 g's), excluding droppings.
- 7.8.8 Measure the four burn lengths. Reference paragraph 7.8.8 of Chapter 7 Supplement for help in determining burn length.

7.9 Report

- 7.9.1 Identify and describe the specimen being tested. Report the type of foam (flame retardant [FR] molded or cut); foam density, if known; and manufacturer and type of FR treatment if known.
- 7.9.2 Report the number of specimen sets tested.
- 7.9.3 Report the pretest and posttest weight of each set, the calculated percentage weight loss of each set, and the calculated average percentage weight for the total number of sets tested.
- 7.9.4 Report each of the four burn lengths for each set tested.

7.10 Requirements

- 7.10.1 For each of the burn lengths measured, the burn length may not exceed 17 inches (43.2 cm) on at least two-thirds of the total number of specimen sets tested. Additionally, the average burn length for each of the measured lengths will not exceed 17 inches.
- 7.10.2 The average percentage weight loss will not exceed 10 percent.
- 7.10.3 The weight loss of at least two-thirds of the total number of specimen sets tested will not exceed 10 percent.

Chapter 7 Supplement

This supplement contains advisory material pertinent to referenced paragraphs.

7.3.2.1 A Monarch 80°AR or 80°R nozzle nominally rated at 2.25 gal/hr (0.142 L/min) at 100 lb/in² (0.71 MPa) and operated at 85 lb/in² (0.6 MPa) gauge, has been found to deliver 2 gal/hr (0.126 L/min) and produce a proper spray pattern. A Monarch 80° Constant Capacity (CC) nozzle, nominally rated at 2 gal/hr at 100 lb/in² and operated between 95 and 105 lb/in² gauge is also acceptable. Minor deviations to the fuel nozzle spray angle, fuel pressure, or other similar parameters are acceptable if the fuel flow rate, temperatures, and heat flux measurements conform to the requirements of sections 7.6 and 7.7.

7.3.2.3 Number 2 diesel fuel, Jet A, or the international equivalent, is the recommended fuel because it has been found to produce satisfactory results if the fuel flow rate and inlet airflow conform to the requirements of sections 7.6 and 7.7.

7.3.2.4 A fuel pressure regulator that is adjusted to deliver 2 ± 0.1 gal/hr (0.126 ± 0.0063 L/min) flow through the nozzle should be provided. An operating fuel pressure of 85 ± 4 psig (0.57 ± 0.03 MPa) for a 2.25 gallons/hour (0.142 L/min) 80° spray angle nozzle has been found satisfactory.

7.3.2.5 The Omega microprocessor-based portable air velocity kit, model HH-30, is a suitable unit. The unit monitors air velocity in feet per minute (FPM) or meters per second (MPS) ± 1 percent reading accuracy, therefore, necessary conversions must be made to attain airflow values. To do this, the area of the opening of the air sensor must be measured. Once the area is found, install the air velocity sensor at the oil burner inlet. Following the procedures prescribed in section 7.6.4, this value should be multiplied by the air velocity reading. The Omega model HH-30 air velocity sensor's area is 0.037 ft². (For example, to achieve an airflow of 67 ft³/min, an air velocity reading of 1811 ft/min must be maintained.)

$$\text{Airflow} = \text{Air Velocity} \times \text{Area of Opening (Air Velocity Sensor)}$$

7.3.4 The thermocouples are periodically subjected to high temperatures during calibration. Because of this type of cycling, the thermocouples may degrade with time. Small but continuing decreases or extreme variations in temperature or "no" temperature reading at all are signs that the thermocouple or thermocouples are degrading or open circuits have occurred. In this case, the thermocouple or thermocouples should be replaced in order to maintain accuracy in calibrating the burner. It is recommended that a record for the amount of time the thermocouples are exposed to the oil burner's flame be kept.

7.3.5 A length of wire can be used to aid in securing the vertical seat cushion to the specimen frame (see figure 7-2). The wire should be uninsulated, solid, 0.032 inch (0.8 mm) or less in diameter and be located no more than 1/2 inch (13 mm) from the top surface of the vertical specimen as it sits in the frame. The wire should not disturb the flame spread behavior of the material(s) being tested. If the flame spread is affected, another wire configuration should be used.

7.3.7 A continuous weighing system is recommended as it allows the operator the ability to monitor weight loss during the test.

7.4.4.2 If, however, several seat models use similar foam combinations, it is not necessary to test each combination if it is possible to bracket the various combinations. For example, if foam "A" makes up 80 percent and foam "B" makes up 20 percent of the foam volume in one seat model and in another similar seat model, foam "A" makes up 20 percent and foam "B" makes up 80 percent of the foam volume, it is generally acceptable to approve all combinations of "A" and "B" foams between these limits if the 20/80 and 80/20 extremes are tested and pass. In addition, for foams of a given chemical composition, low-density foam can be used in lieu of foams of higher density. In this case, as in the case of foam combinations, all other elements that make up the cushion must be the same (see figure 7-7).

7.4.4.3 When any seat construction tested has passed, a separate test is not required for another seat construction if the only difference from the first test is the dress covering, provided the replacement dress covering is comprised of a similar weave design and fiber type, as described in section 7.4.4.3.2 and the burn length of the replacement dress covering, as determined by the Bunsen burner test specified in FAR 25.853(b), does not exceed the burn length of the dress covering used for the test.

Test specimens are intended to represent the principal material elements and construction methods of the production seats. Items decorative in nature, such as buttons, detail stitching, hand-hold straps, velcro attached strips, or thin outer cover paddings, such as armrest covers and filler around food trays, that do not penetrate the fire-blocking layer when fastened are not required to be represented on the test specimen. Dress cover details and items not associated with the cushion construction, such as metal seat pans or other metal structures, should not be included in the specimen weight since they are not part of the principal seat construction. Layers of padding or filler immediately under the dress cover material are considered to be part of the dress cover material and should be included in the test specimens.

Similar dress covering (from Advisory Circular 25.853-1, "Flammability of Aircraft Seat Cushions," Sections 5d[1] and [2]) refers to dress covering materials having the same material composition, weave style, and weight. Material blends can be considered similar when the constituent materials fractions are the same, ± 6 percent, as the tested material. Examples of different weave styles include plain, jacquard, or velvet. With regard to weight, lighter fabrics are generally more critical than heavier fabrics. Due to the severe shrinking and unpredictable distortion experienced by leather dress cover materials, similarity approvals for leather are not recommended.

Certification by similarity to previously tested dress covers should be limited to instances where the material composition is the same and the weight and weave type are essentially the same. In all cases, results of the Bunsen burner test per FAR 25.853(b) for the new material should be equal to or better with respect to burn length than the tested material. In addition, it may be useful to evaluate the weight loss and burn length results of the oil burner test to determine if the tested material is a good basis for similarity; that is, the closer weight loss and burn length with the oil burner are to the maximum allowed, the more alike the dress covering materials should be for similarity. In general, test data and resultant experience gained from conducting tests should also be a major source of information to determine if approval by similarity is acceptable.

7.6.2 The language of paragraph 7.6.2 in the handbook can be met by measuring the vertical air flow at four points. These points are located behind the vertical specimen, 1/2 inch (113 mm) from the rear-facing vertical surface, 2 inches (305 mm) below the vertical specimen top surface, 2 inches (305 mm) above the vertical specimen bottom surface, and horizontally positioned 6 inches (152 mm) from each side. The measurements do not need to be made simultaneously, precluding the need for multiple anemometers. However, these measurements should be made in the same calibration cycle. The horizontal air velocity can be measured 1/2 inch (13 mm) above the geometric center of the upper horizontal surface.

7.6.3 If this measurement method is used to determine the fuel flow rate, the person(s) performing the measurement should realize that flammable vapors should be present in the test chamber. Caution must be exercised during the measurement period to avoid all possible ignition dangers.

If a calibrated flow meter is not available, measure the fuel flow rate using a 300 to 500 millimeter graduated cylinder or beaker, a 1/2 inch (13 mm) or large diameter rubber or plastic drain tube, and a timer.

There are two items that need consideration because they can affect the measurement accuracy. First, if a tube of insufficient diameter is used, conduit flow in the tube should add an additional back pressure to the nozzle flow. Second, when reading the collection vessel to determine the fuel volume delivered by the nozzle, ensure that the vessel is level and the fluid level is measured by reading the height of the meniscus. If either of these items is not considered, grave errors in fuel flow measurement can result.

The directions for finding the fuel flow rate follow. Remove the oil burner draft tube. Place the drain tube over the nozzle orifice. Drape the tube into the collection vessel, which is at a level lower than the nozzle. Ensure that the

ignitor system is turned off, then turn on the fuel pump and burner motor. Collect the fuel in the graduated cylinder or beaker for a 2-minute period. Measure the fuel volume delivered and calculate the fuel flow rate.

$$2 \text{ gallons/hour} = 126 \text{ millimeters/minute}$$

7.7 Static disks were recently developed to stabilize the air before entering the combustion area. Two were designed by Park Oil Burner Manufacturing Company of Atlantic City, New Jersey. The Park Oil Burner disks are both made of steel. See figure 7-10 for details on disks. Disks 1 and 2 are made for easy assembly, only requiring the removal of the draft tube and installation of the disk. Disk 3 was developed by CEAT, the French Ministry of Defense. The disk is made of a Nomex honeycomb material. CEAT uses two honeycomb disks positioned behind the stabilizer.

These disks are an optional feature and are used (any one or more of the three) to help produce a more full and even flame pattern. However, there is no guarantee of achieving calibration using a disk with all of the various makes and models of burners used throughout the industry.

7.7.1.1 Operating the calorimeter without water running through it could permanently damage the calorimeter.

7.7.2 A stainless steel wire brush is one possible cleaning tool. Soot buildup inside the burner cone can affect the flame characteristics and cause calibration difficulties. Since the burner cone may distort with time, dimensions will need to be checked periodically.

7.7.7 Calibrate the burner prior to each test until consistency has been demonstrated. After consistency has been confirmed, several tests can be conducted with calibration before and after each series of tests.

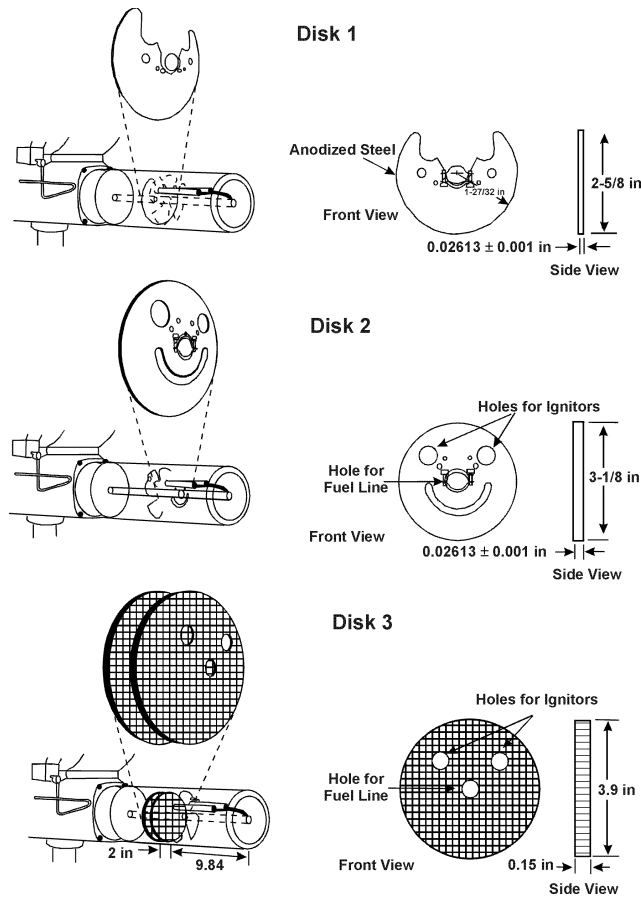

Figure 7-10. Static Disk Illustration

Recommendations for achieving calibration temperatures:

1. Set the stabilizer 3.25 ± 0.25 inches from the end of the draft tube.
2. Rotate the ignitor to the 6 o'clock and 9 o'clock position (viewpoint: looking toward the stabilizer from the end of the draft tube).
3. Seal all possible air leaks around the burner cone and draft tube area.
4. Use static disk to improve flame characteristics. See figure 7.9 for information on disks.

7.8.8 An industry practice acceptable to the FAA for determining specimen damage length, in order to measure burn length, has been to use an object with a dull point, such as a pencil, and scrape the dress covering. If the object used penetrates the dress covering, damage has occurred due to that area's combustion. If the dress covering is not penetrated, damage has occurred due to pyrolysis and is not considered damaged by combustion.

Chapter 8 Oil Burner Test for Cargo Liners

8.1 Scope

8.1.1 This test method evaluates the flame penetration resistance capabilities of aircraft cargo compartment lining materials utilizing a high-intensity open flame to show compliance to the requirements of FAR 25.855.

8.2 Definitions

8.2.1 Burnthrough

Burnthrough is defined as flame penetration of the test specimen.

8.2.2 Specimen Set

A specimen set consists of three or more replicates of a ceiling and sidewall cargo liner panel installation.

8.3 Apparatus

8.3.1 Test Specimen Frame

The test specimen frame is shown in figures 8-1 through 8-3. The burner will be mounted on a swiveling device capable of allowing it to be directed away from the test specimen during warmup.

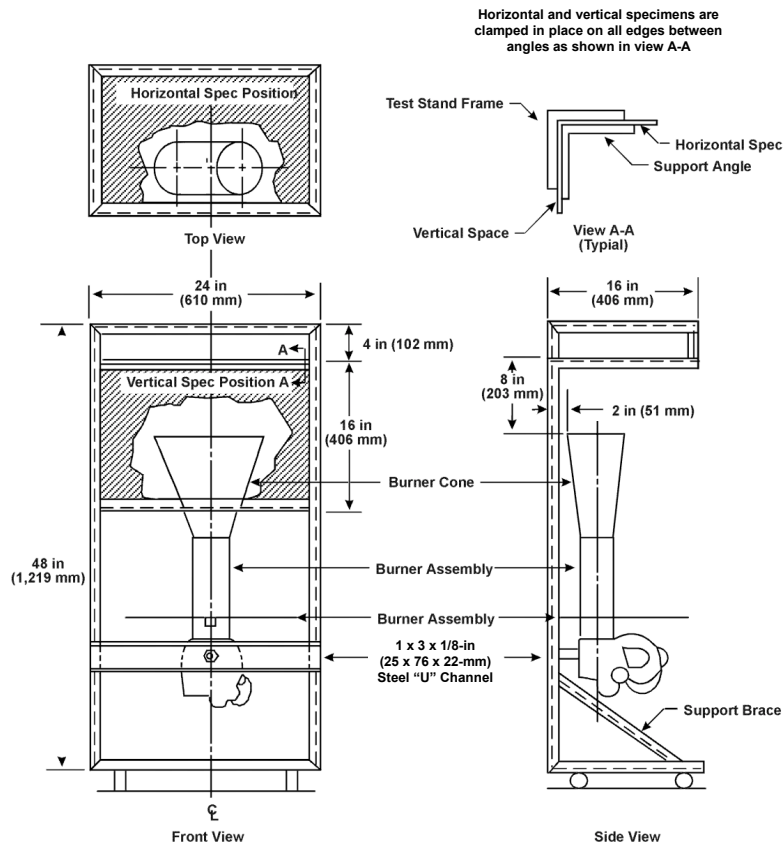

Figure 8-1. Test Apparatus for Horizontal and Vertical Mounting for Cargo Liner Oil Burner Testing

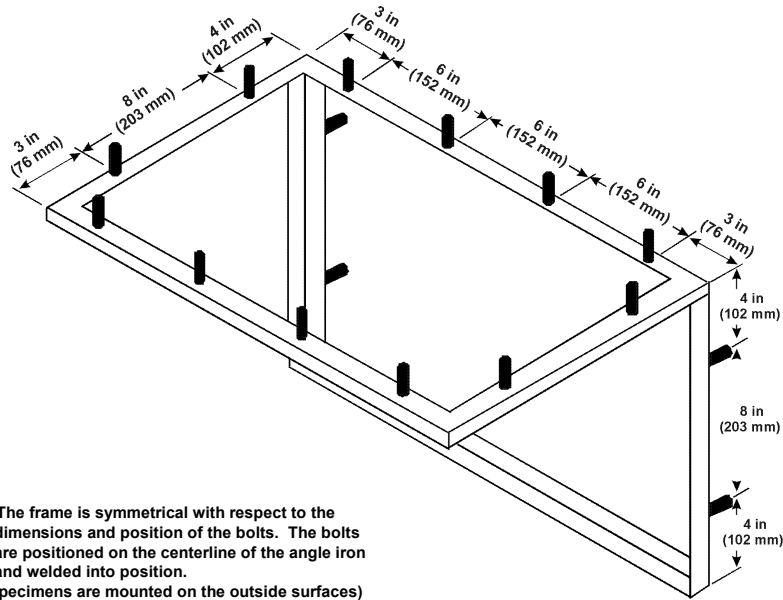

Figure 8-2. Cargo Liner Test Specimen Frame

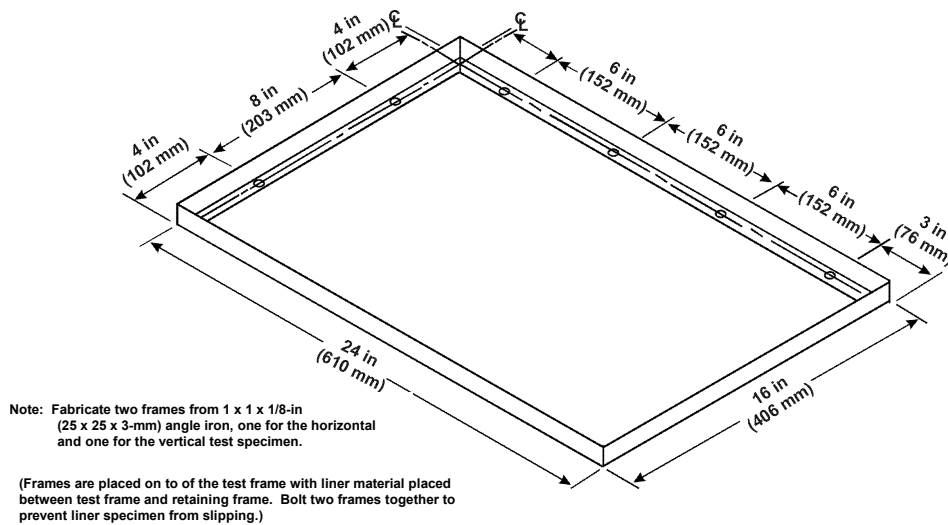

Figure 8-3. Cargo Liner Test Specimen Retaining Frame

8.3.2 Test Burner

The burner will be a modified gun type, such as Park Model DPL 3400, Lennox Model OB-32, or Carlin Model 200 CRD. Flame characteristics can be enhanced by the optional use of a static disk or tabs. Major deviations, such as a different burner type, should have thorough comparison testing. Temperature and heat flux measurements, as well as test results, must correspond to those produced by an FAA approved burner.

8.3.2.1 Nozzle

A nozzle will be provided to maintain the fuel pressure to yield a nominal 2 ± 0.1 gal/hr (0.126 ± 0.0063 liter/min) fuel flow (see Chapter 8 Supplement).

8.3.2.2 Burner Cone

A $12 \pm 1/8$ -inch (305 ± 3 -mm) burner cone will be installed at the end of the draft tube. The cone will be made of stainless steel or a similar type of noncorrosive high-temperature metal and will have a thickness of 0.065 ± 0.015 inch (1.65 ± 0.375 mm). The opening of the cone will be $6 \pm 1/4$ inches (152 ± 6 mm) high and $11 \pm 1/4$ inches (280 ± 6 mm) wide (see figures 8-4a and 8-4b).

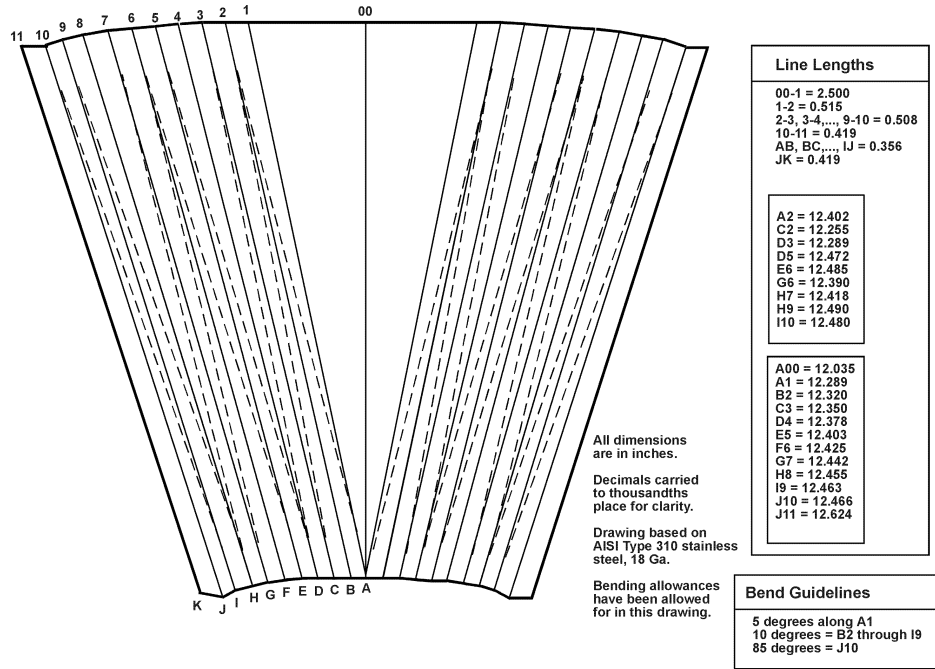

Figure 8-4a. Burner Cone Layout and Bending Pattern

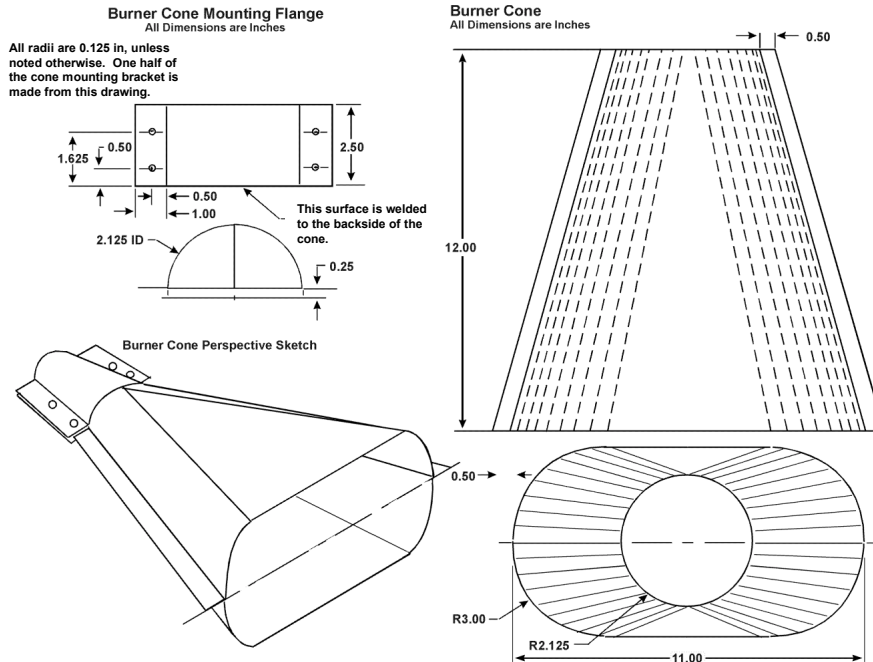

Figure 8-4b. Burner Cone Details

8.3.2.3 Fuel Pressure Regulator

A fuel pressure regulator, adjusted to deliver 2 gal/hr \pm 0.1 gal/hr (0.126 liter/min), will be provided (see Chapter 8 Supplement).

8.3.2.4 Fuel

Either number 2 Grade kerosene or American Society for Testing and Materials (ASTM) D2 fuel (number 2 Grade fuel oil) will be used.

8.3.2.5 Burner Airflow

Adjust the shutter to attain an airflow of 67 \pm 4 ft³/min (1.89 \pm 0.011 m³/min). See paragraph 8.3.5.2 of Chapter 8 Supplement.

8.3.3 Calorimeter

The calorimeter will be a total heat flux density, foil type Gardon Gauge of an appropriate range, such as 0-15 Btu/(ft² second) (0-17 W/cm²), accurate to \pm 3 percent of the indicated reading.

8.3.3.1 Calorimeter Mounting

The calorimeter will be mounted in a 6 by 12 \pm 1/8-inch (152 by 305 \pm 3-mm) by 3/4-inch (19-mm) -thick insulating block that is attached to a steel angle bracket for placement in the test stand during burner calibration (see figure 8-5). The insulating block will be monitored for deterioration and the mounting shimmed as necessary to ensure that the calorimeter face is parallel to the exit plane of the test burner cone.

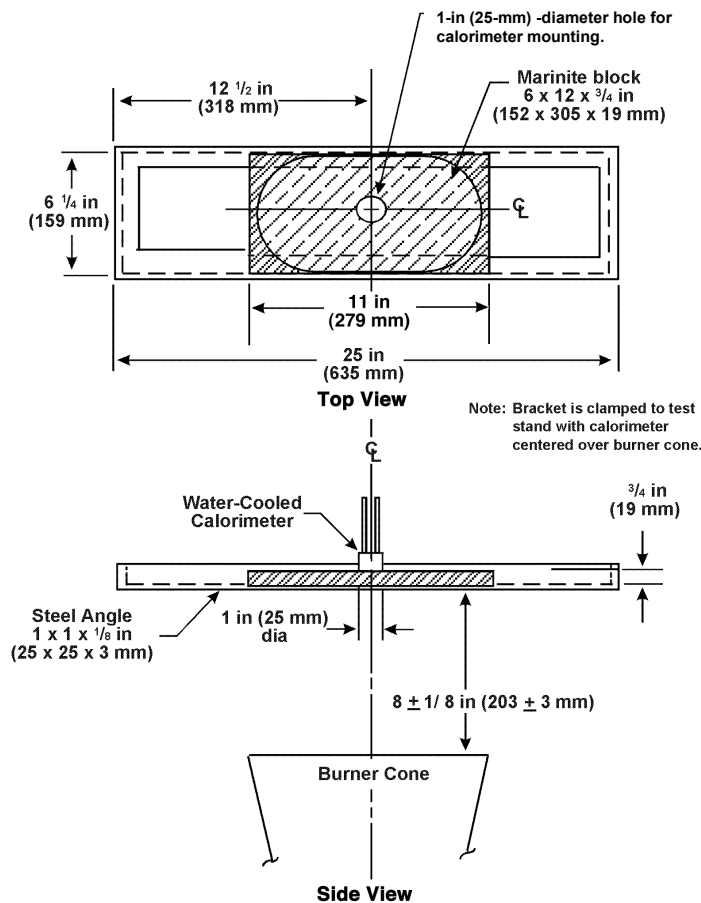

Figure 8-5. Top and Side Views of Calorimeter Bracket

8.3.4 Thermocouples

The seven thermocouples to be used for calibration will be 1/16-inch (1-mm) ceramic packed, metal sheathed, type K (Chromel-Alumel), grounded junction thermocouples with a nominal 30 AWG size conductor. The seven thermocouples will be attached to a steel angle bracket to form a thermocouple rake for placement in the test stand during burner calibration, as shown in figure 8-6.

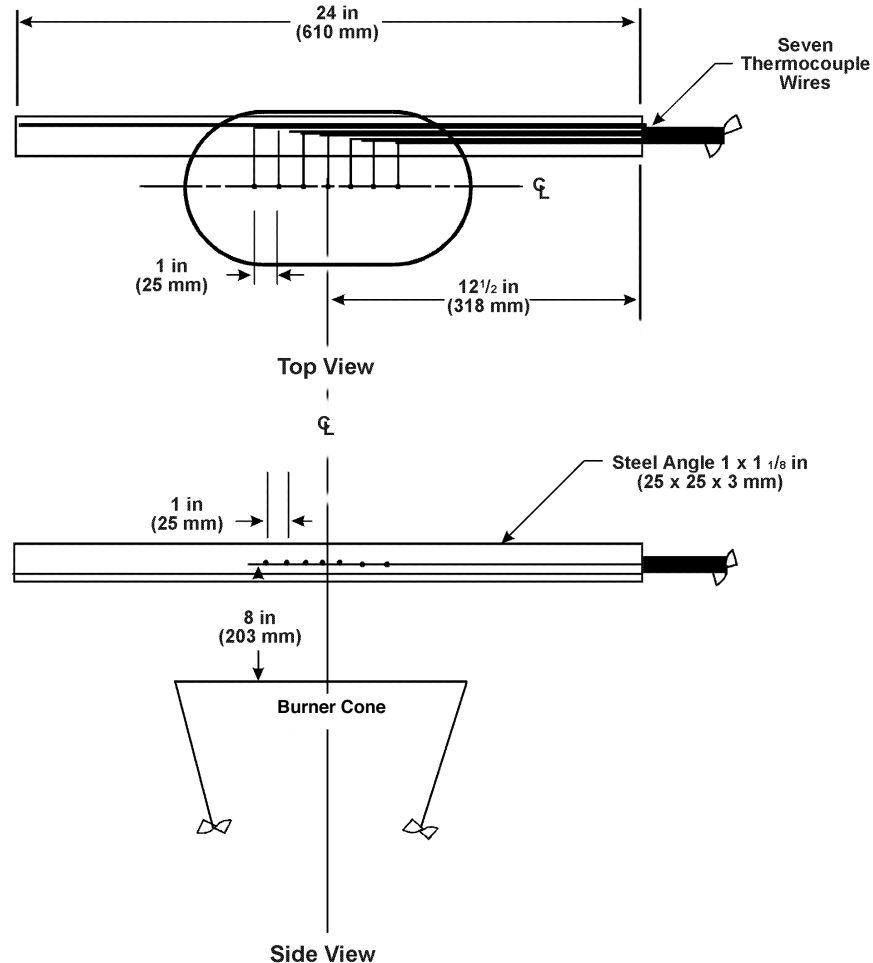

Figure 8-6. Top and Side View of Thermocouple Rake Bracket

8.3.5 Instrumentation

A calibrated recording device or a computerized data acquisition system with an appropriate range will be provided to measure and record the outputs of the calorimeter and the thermocouples.

8.3.5.1 Timing Device

A stopwatch or other device, accurate to within 1 second/hour, will be provided to measure the time of application of the burner flame, the material flaming time, and the burnthrough time.

8.3.5.2 Anemometer

A vane-type air velocity sensing unit will be used to monitor the flow of air at the inlet of the oil burner. The inlet will be completely sealed except for an opening for the air velocity

sensor where the inlet will be centered and mounted. See the anemometer setup in figure 8-7.

8.4 Test Specimen(s)

8.4.1 Specimen Configuration

Each cargo liner panel type and design configuration will be tested. Design configuration includes cargo compartment design features such as corners, joints, seams, lamp assemblies, pressure relief valves, temperature sensors, etc., that may affect the capability of a cargo compartment to safely contain a fire.

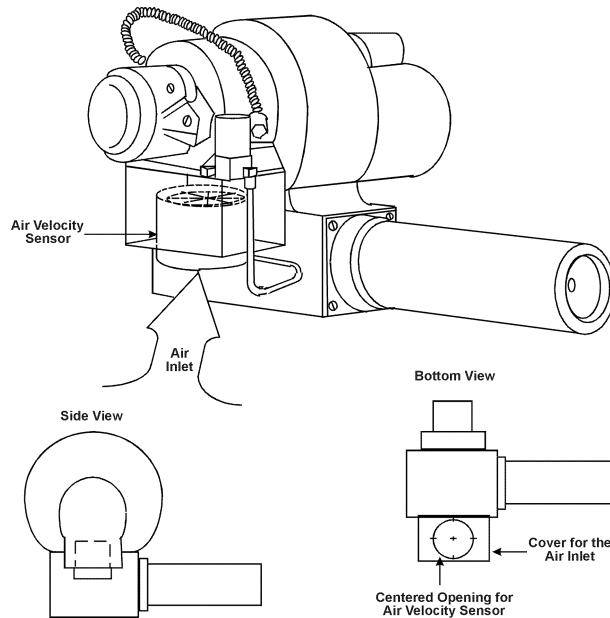

Figure 8-7. Illustration for the Location of the Air Velocity Sensor

8.4.1.1 Ceiling and sidewall liner panels may be tested individually provided a baffle of fire-resistant material, such as Kaowool or Marinite, is used to simulate the missing panel.

8.4.2 Specimen Number

A minimum of three specimens or specimen sets for each panel type or design configuration will be prepared for testing.

8.4.3 Specimen Size

The specimens to be tested will measure $16 \pm 1/8$ inches (406 ± 3 mm) by $24 \pm 1/8$ inches (610 ± 3 mm).

8.5 Specimen Conditioning

8.5.1 The specimens will be conditioned at $70^\circ \pm 5^\circ\text{F}$ ($21^\circ \pm 2^\circ\text{C}$) and $55\% \pm 10\%$ relative humidity for a minimum of 24 hours prior to testing.

8.6 Preparation of Apparatus

8.6.1 The air inlet of the oil burner must be completely sealed except for an opening where the air monitoring device will be placed. With the anemometer setup for measuring, turn the motor on and run it for at least 30 seconds to allow the blower to reach its operating speed (it is not necessary for the ignitor and fuel flow to be turned on). Set the airflow to 67 ± 4 ft³/min (1.89 ± 0.011 m³/min) by adjusting the air

shutter (see paragraph 8.3.5.2 of Chapter 8 Supplement for airflow conversion). Once this airflow value is attained, keep the air shutter in position by tightening the lock screw. This will be the initial airflow setting. Later adjustments may be necessary to reach calibration temperatures and heat flux within the specified airflow range.

- 8.6.2 If a calibrated flow meter is not available, measure the fuel flow using a graduated cylinder of appropriate size. Turn on the fuel pump and the burner motor, making sure the igniter system is off. Collect the fuel by placing a plastic or rubber tube into the graduated cylinder for a 2-minute period. Ensure that the flow rate is 2 ± 0.1 gal/hr (0.126 ± 0.0063 L/min).

8.7 Calibration

- 8.7.1 Secure the calorimeter in its bracket and place it on the specimen mounting test frame, making sure it is centered over the burner cone at a distance of $8 \pm 1/8$ inches (203 ± 3 mm) from the exit of the burner cone, as shown in figure 8-5. Ensure that the burner is in the proper position relative to the specimen mounting frame, $2 \pm 1/8$ inches (51 ± 3 mm) from the sidewall panel frame. Position the center of the calorimeter over the center of the burner cone.
- 8.7.2 Prior to starting the burner, ensure that the calorimeter face is free of soot deposits and that there is water running through the calorimeter.

CAUTION! Exposing the calorimeter to the burner flame without water running through it will destroy the calorimeter.

- 8.7.3 Rotate the burner from the test position to the warmup position. Examine and clean the burner cone of any evidence of buildup of productions of combustion, soot, etc.
- 8.7.4 While the burner is in warmup position, turn on the fuel flow and light the burner. Allow it to warmup for at least 2 minutes. Move the burner into test position and adjust the air intake to produce a heat flux density of 7.5 Btu/(ft² second) (8.6 W/cm²) or greater. Record the heat flux density measurements at least once per second averaged over a 30-second time period to ensure that steady-state conditions have been achieved. After steady-state conditions have been achieved, turn the burner off.
- 8.7.5 Replace the calorimeter bracket with the thermocouple rake. Check the distance of each of the seven thermocouples to ensure that they are located $8 \pm 1/8$ inches (203 ± 3 mm) from the horizontal plane of the burner exit. Place the center thermocouple (thermocouple number 4) over the center of the burner cone exit (see figure 8-6).
- 8.7.6 Turn on the burner and allow it to warm up for at least 2 minutes. After warmup, record the temperature of the thermocouples at least once per second averaged over a 30-second time period. The temperature of each thermocouple will be 1600°F (871°C) or greater.
- 8.7.7 If the temperature of each thermocouple is not within the specified range, repeat sections 8.7.1 through 8.7.3 until all parameters are within the calibration range. When required thermocouple temperatures have been achieved, check that the airflow is within the required range. Once the parameters are within the specified range, secure the air shutter by tightening the lock screw.
- 8.7.8 Calibrate prior to each test until consistency (heat flux and temperature remaining within calibration tolerance) has been demonstrated. After consistency has been confirmed, several tests can be performed with calibration conducted before and after the tests. See this chapter's supplement for recommendations on achieving calibration.

8.8 Procedure

- 8.8.1 Examine and clean the cone of soot deposits and debris.
- 8.8.2 Mount the sidewall and/or ceiling cargo liner specimen(s) on the respective frame(s) and secure to the test frame(s) using the retaining frame(s). Bolt the retaining frame(s) and the test frame(s) together. Verify that the horizontal test frame is level.

- 8.8.3 Mount the thermocouple or thermocouple rake $4 \pm 1/8$ inches (102 ± 3 mm) above the horizontal ceiling panel test specimen. If the thermocouple rake is being used, position the center thermocouple (thermocouple number 4) over the center of the burner cone exit.
- 8.8.4 Move the burner into warmup position so that the flame does not impinge on the test specimen during the warmup period. Turn on the burner and allow it to stabilize for at least 2 minutes.
- 8.8.5 Move the burner into test position, then start the timing device.
- 8.8.6 Record the temperature of the thermocouple (thermocouple number 4, if using the thermocouple rake also used for calibration) at least once a second for the duration of the test.
- 8.8.7 Expose the specimen to the flame for 5 minutes or until flame penetration occurs.
- 8.8.8 The following sections present testing procedures for patch repairs, seams, joints, fastening systems, lighting fixtures, and corners.
 - 8.8.8.1 Patch Repairs
See Chapter 15 for instructions.
 - 8.8.8.2 Seams, Joints, Fastening Systems, Lighting Fixtures, and Corners
The barrier material used for design features such as recessed lighting fixtures and pressure relief valves will be tested in the same manner as a cargo liner specimen. Seams, joints, and fasteners in the ceiling position will be tested longitudinally extending the length of the liner and centered over the burner cone. Seams or joints used on the sidewall will be positioned 2 inches from the top of the liner longitudinally as representative of the aircraft application. Apply the test procedures in sections 8.8.1 through 8.8.8 to test these design features.
- 8.8.9 Turn off the burner to terminate the test.

8.9 Report

- 8.9.1 Report a complete description of the material(s) being tested, including manufacturer, thickness, etc.
- 8.9.2 Report the orientation of the panels tested (i.e., ceiling and/or sidewall).
- 8.9.3 Record any observations regarding the behavior of the test specimen during flame exposure, such as delamination, resin ignition, smoke, etc., and the time each event occurred.
- 8.9.4 Report the time of occurrence of flame penetration, if applicable, for each of the three specimens tested.
- 8.9.5 If flame penetration does not occur, report the maximum backside temperature and time of occurrence.
- 8.9.6 Provide a record of calibration.

8.10 Requirements

- 8.10.1 None of the three specimens tested will burn through within the 5-minute flame exposure.
- 8.10.2 Each of the three specimens tested will not exceed 400°F at the backside temperature monitored during flame exposure.
- 8.10.3 Specimens that pass in the ceiling orientation may be used as a sidewall panel without further test.
- 8.10.4 For the patch adhesion test, the patch must be intact after the 5-minute flame exposure.

Chapter 8 Supplement

This supplement contains advisory material pertinent to referenced paragraphs.

8.3.2 The basic burner and the use of tabs are described in FAA Powerplant Engineering Report No. 3A, "Standard Fire Test Apparatus and Procedure for Flexible Hose Assemblies," dated March 1978, and Report No. DOT/FAA/RD/76/213, "Re-evaluation of Burner Characteristics for Fire Resistant Tests," dated January 1977. The test settings specified in this specification, however, differ from those specified in the above reports.

8.3.2.1 A Monarch 80-degree AR or 80°R nozzle, nominally rated at 2.25 gal/hr (0.142 L/min) at 100 lb/in² (0.69 MPa) and operated at 85 lb/in² (0.59 MPa) gauge, has been found satisfactory to maintain a fuel flow of 2 gal/hr (0.126 L/min) and produce a proper spray pattern. A Monarch 80-degree CC nozzle, nominally rated at 2 gal/hr at 100 lb/in² and operated between 95 and 105 lb/in² gauge, is also acceptable. Minor deviations to the fuel nozzle spray angle, fuel pressure, or other parameters of the nozzle are acceptable if the fuel flow rate, flame temperature, and burner heat flux density conform to the requirements of section 8.6 of the handbook.

8.3.2.3 A fuel pressure regulator that is adjusted to deliver 2 ± 0.1 gal/hr (0.126 ± 0.0063 L/min) flow through the nozzle should be provided. An operating fuel pressure of 85 ± 4 psig (0.57 ± 0.03 MPa) for a 2.25 gal/hr (0.142 L/min) 80-degree spray angle nozzle has been found satisfactory.

8.3.2.4 Number 2 Grade diesel fuel, Jet A, or the international equivalent is the recommended fuel because it has been found to produce satisfactory results if the flow rate and inlet airflow conform to the requirements of sections 8.6 and 8.7 of the handbook.

8.3.4 The thermocouples are subjected to high temperatures durations during calibration. Because of this type of cycling, the thermocouples may degrade with time. Small but continuing decreases or extreme variations in temperature or "no" temperature reading at all are signs that the thermocouple or thermocouples are degrading or open circuits have occurred. In this case, the thermocouple or thermocouples should be replaced in order to maintain accuracy in calibrating the burner. It is recommended that a record be kept for the amount of time the thermocouples are exposed to the oil burner's flame.

8.3.5.2 The Omega microprocessor-based portable air velocity kit, model HH-30, is a recommended unit. The kit includes a vane-type air velocity sensor, hand-held digital readout displaying air velocity, extension rods, and a 9-volt lithium battery. Since the unit monitors air velocity in FPM or MPS ± 1 percent reading accuracy, necessary conversions must be made to attain airflow values. To do this, the area of the opening of the air sensor must be measured. Once the area is found, install the air velocity sensor at the oil burner inlet (see figure 8-7 for location). Following the procedures prescribed in section 8.6.1, this value should be multiplied by the air velocity reading. (The area of the air velocity sensor for the Omega model HH-30 is 0.037 ft² [0.0034 m²]. As an example, by maintaining an air velocity reading of 1800 ft/min using the Omega air sensor described above, an air flow of 67 ft³/min should be achieved.) If an air velocity sensor other than the Omega model HH-30 is being used, the same conversions apply.

$$\text{Airflow} = \text{Air Velocity} \times \text{Area of Opening (Air Velocity Sensor)}$$

8.6.1 An alternate method of airflow measurement involves removing the burner extension from the end of the draft tube. Turn on the blower portion of the burner without turning on the fuel or ignitors. Measure the air velocity using a hot-wire anemometer. Adjust the airflow using the damper so that the airflow is in the range of 1550 to 1800 ft/min (762 to 914 cm/second). (If tabs are being used, the tabs should be removed prior to measuring the airflow. After the measurement is complete, reinstall the tabs and the cone extension.)

8.7 Static Disks

Static disks were recently developed to stabilize the air before entering the combustion area. Two were designed by Park Oil Burner Manufacturing Company of Atlantic City, New Jersey. The Park Oil Burner disks are both made of steel. See figure 8-8 for details on the disks. Disks 1 and 2 are made for easy assembly, only requiring the removal of the draft tube and installation of the disk. Disk 3 was developed by CEAT, the French Ministry of Defense. The disk is made of a Nomex honeycomb material. CEAT uses two honeycomb disks positioned behind the stabilizer.

These disks are an optional feature and are used (any one or more of the three) to help produce a more full and even flame pattern. However, there is no guarantee of achieving calibration using a disk with all of the various makes and models of burners used throughout the industry.

8.7.3 A stainless steel wire brush is one possible cleaning tool. Soot buildup inside the burner cone can affect the flame characteristics and cause calibration difficulties. Since the burner cone may distort with time, dimensions will need to be checked periodically.

8.7.4 The airflow should be adjusted to produce the proper flame as well as the proper temperature and heat flux density. Two different flame profiles may yield the same temperature and heat flux density. The correct flame is generally 8 to 10 inches in length and orange-yellow in color.

8.7.8 Following are recommendations for achieving calibration temperatures and heat flux:

1. Set the stabilizer 3.25 ± 0.25 inches from the end of the draft tube.
2. Rotate the ignitor to the 6 o'clock and 9 o'clock position (viewpoint: looking toward the stabilizer from the end of the draft tube).
3. Seal all possible air leaks around the burner cone and draft tube area.
4. Use static disk to improve flame characteristics.
5. Replace thermocouples after 50 hours of use.

8.8.8.2 Test procedures for cargo liner design features are described in FAA Technical Note DOT/FAA/CT-TN88/33, dated September 1988.

8.10.1 Flames that may appear on the side of the specimen away from the burner or as a result of the ignition of flammable smoke and/or gases produced from the specimen by the heat from the burner do not constitute burnthrough. Burnthrough occurs only if the flame from the burner passes through the specimen.

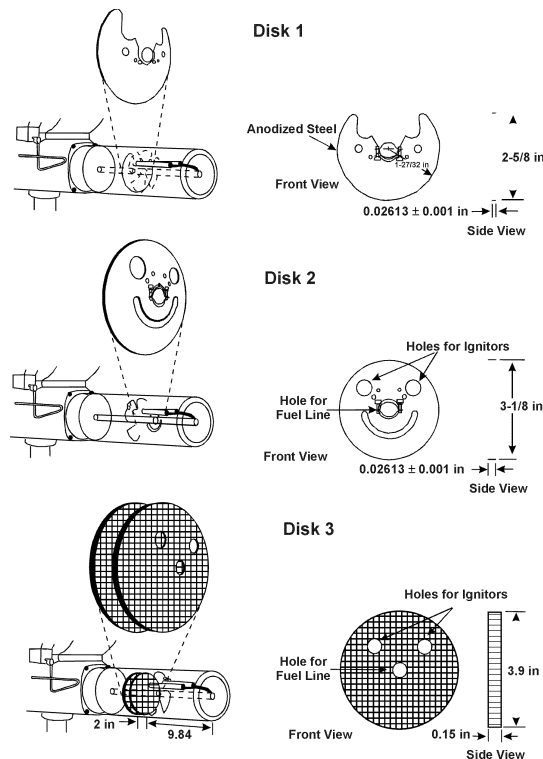

Figure 8-8. Static Disk Illustration

Chapter 9 Radiant Heat Testing of Evacuation Slides, Ramps, and Rafts

9.1 Scope

9.1.1 This method is used to show compliance to Technical Standard Order (TSO) C69A.

9.2 Definition

9.2.1 Time to Failure

The time to failure is the time between first application of heat to the specimen and the first decrease in pressure below the maximum pressure attained in the test cylinder during the test.

9.3 Test Apparatus

9.3.1 Pressure Cylinder and Specimen Holder

The pressure cylinder will consist of a 12 3/8-inch (314-mm) -long aluminum cylinder with a 7 inch (178 mm) outside diameter and a 6 1/2 inch (165 mm) inside diameter, as shown in figures 9-1, 9-2, and 9-3.

9.3.1.1 An aluminum plate 1/2 inch (13 mm) thick will be welded to one end of the cylinder and will be drilled and tapped near its upper edge for a 1/4-inch (6.4-mm) American Standard taper pipe thread to facilitate the hook up of air pressure and pressure recording equipment.

9.3.1.2 An aluminum ring 7 inches (178 mm) in outer diameter, 5 1/2 inches (140 mm) in inner diameter, and 1/2 inch (13 mm) thick will be welded to the other end of the cylinder. The ring will have eight evenly spaced 10-32 bolt holes on the circle 5/16 inch (8 mm) from the ring's inner edge. (The diameter of this circle is 6 1/8 inches [156 mm] and adjacent bolt holes are 2 5/16 inches [60 mm] apart.) A 10-32 steel bolt 7/8 inch (22 mm) long will be placed into each of the holes.

9.3.1.3 An aluminum ring, 6 3/4 inches (171 mm) in outer diameter, 5 1/2 inches (140 mm) in inner diameter, 1/2 inch (13 mm) thick, and two neoprene rubber gaskets with similar clearance holes to fit over the bolts will provide a means for clamping and sealing the test specimen in place. Hinges and adjustable stops will be welded to the sides of the cylinder, as shown in figures 9-1, 9-2, and 9-3.

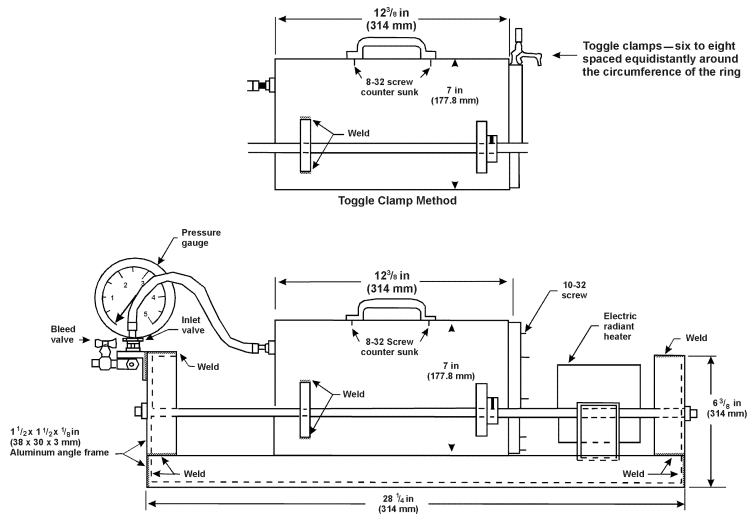

Figure 9-1. Evacuation Slide Material Test Apparatus – Front View

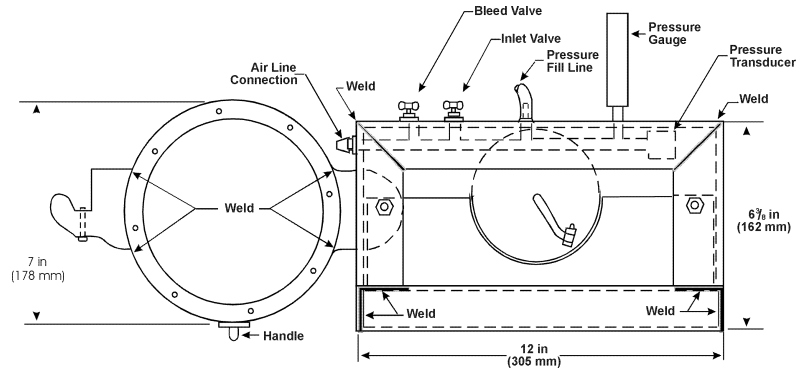

Figure 9-2. Evacuation Slide Material Test Apparatus – Side View

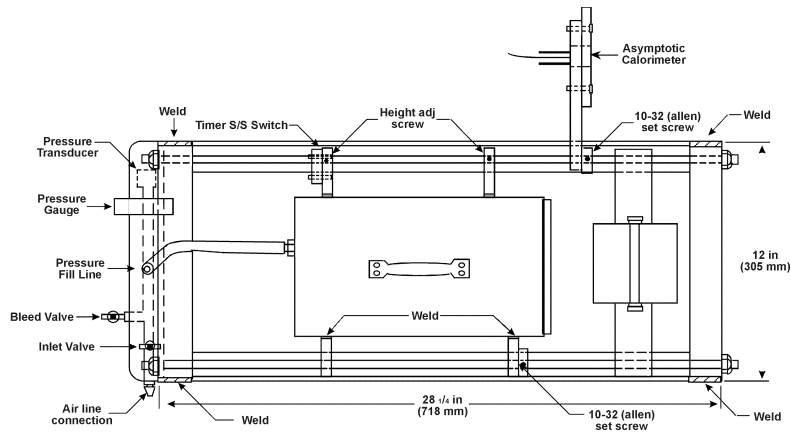

Figure 9-3. Evacuation Slide Material Test Apparatus – Top View

9.3.2 Electric Furnace

An electric furnace with a 3-inch (76-mm) -diameter opening, as shown in figure 9-4, will be provided to supply a constant irradiance on the specimen surface. The Smoke Density Chamber radiant heat furnace, or equivalent, has been found suitable.

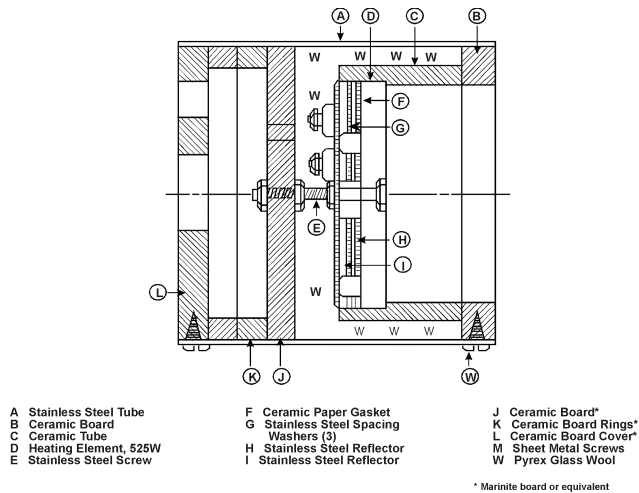

Figure 9-4. Furnace Details

9.3.3 Furnace Voltage Control

A variable voltage control, 115V, 600W minimum, will be provided to connect to the electric furnace power supply to adequately control the heat flux from the furnace. The furnace control system will be capable of maintaining the irradiance level under steady-state conditions for a minimum of 20 minutes.

9.3.4 Calorimeter

A 0 to 5 Btu/ft²-sec calorimeter will be provided to monitor the heat flux from the furnace. The calorimeter will be mounted in a 4 1/2-inch (114-mm) -diameter by 3/4-inch (19-mm) -thick insulating block, such as calcium-silicate millboard, with the surface of the calorimeter flush with the surface of the insulating block. The calorimeter will be hinged to one of the sliding bars of the framework and centered with the furnace (see figure 9-3).

9.3.5 Apparatus Framework

The pressure cylinder, calorimeter, and furnace are mounted on a framework, as detailed in figure 9-3. Adjustable sliding stops are located on each of the bars for setting the cylinder and calorimeter at any distance from the opening of the furnace.

9.3.6 Pressure Supply and Equipment

Compressed air is connected to the cylinder through a needle valve attached to the end of the framework. A tee-manifold on the outlet side of the valve provides for a 0 to 5 psig pressure gauge, a transducer, a flexible tube to supply air to the rear plate of the pressure cylinder, and a bleed valve, as shown in figure 9-1.

9.3.7 Instrumentation

The outputs of the calorimeter and pressure transducer are measured and recorded using a recording potentiometer or other suitable instrument capable of measurement over the range required.

9.4 Test Specimens

9.4.1 For each test, at least three specimens, 7 inches (178 mm) in diameter with eight 1/4-inch (6-mm) holes punched in the material to match the studs in the pressure cylinder, will be cut from the material to be tested.

9.4.2 If the pressure holding material has any exposed surfaces that are marked, overlay material, seams, or are altered in any other manner that affects radiant heat resistance, each different surface will be tested as a specimen set.

9.5 Conditioning

9.5.1 Condition test specimens at 70° ± 5°F (21° ± 3°C) relative humidity for a minimum of 24 hours prior to testing.

9.6 Calibration

9.6.1 Turn on the radiant heat furnace and other required instrumentation and allow 1/2 to 3/4 hours to stabilize heat output and for instrumentation warmup.

9.6.2 Adjust the transformer to produce a radiant heat flux density of 2 Btu/ft²-sec (2.3 W/cm²) when the calorimeter is positioned at approximately 1 1/2 inches (38 mm) in front of the radiant heat furnace.

9.6.3 Find the precise location in front of the furnace where the test heat flux density of 1.5 Btu/ft²-sec (1.7 W/cm²) is achieved by sliding the calorimeter on the horizontal bar and fixing the position with the sliding stop. Swing the calorimeter out of position.

9.7 Procedure

- 9.7.1 Conduct the tests in a draft free room or enclosed space. It is recommended that tests be conducted under a hood or other means to remove potentially hazardous gases from the test area.
- 9.7.2 Turn on the radiant heat furnace and other required instrumentation and allow 1/2 to 3/4 hours to stabilize heat output and for instrumentation warmup.
- 9.7.3 Rotate the cylinder away from the furnace. Mount the specimen with the reflective surface of the material facing the furnace on the open end of the cylinder and with a neoprene gasket on each side of the specimen. Place the aluminum ring on the studs and tighten the nuts so that an airtight seal is achieved.
- 9.7.4 Pressurize the cylinder to the slide material nominal operating pressure and check for leakage.
- 9.7.5 Locate the pressure cylinder so that the distance from the test specimen to the surface of the radiant heat furnace is the distance established in section 9.6.3.
- 9.7.6 Place the calorimeter in front of the radiant heat furnace at the distance established in section 9.6.3 and record the heat flux density. Verify that the heat flux is $1.5 \text{ Btu/ft}^2\text{-sec}$ (1.7 W/cm^2). Remove the calorimeter.
- 9.7.7 Rotate the pressure cylinder with the test specimen in front of the radiant heat furnace. Start the timer.
- 9.7.8 Monitor the pressure cylinder from the time the specimen is placed in front of the furnace until the first observed pressure loss.
- 9.7.9 Record time to failure in seconds.

9.8 Report

- 9.8.1 Report material description and full identification that may include type of fabric and coating, manufacturer, manufacturer style number, weight, thickness, color, and any alterations, if applicable.
- 9.8.2 Report the test conditions, including the heat flux density and starting pressure for each of the three specimens.
- 9.8.3 Report any observations of the material behavior during the test and times of occurrence.
- 9.8.4 Report the time to failure for each of the three specimens and the overall average.

9.9 Requirement

- 9.9.1 The average time to failure for the three specimens tested will not be less than 90 seconds.

Chapter 9 Supplement

This supplement contains advisory material pertinent to referenced paragraphs.

9.3.1 Figure 9-1 represents an alternative method of securing the specimen in place on the holder by using toggle clamps instead of welded hinges and adjustable stops.

9.3.2 The electric furnace is available from Superpressure, Inc., 8030 Georgia Avenue, Silver Springs, Maryland 20910 (Catalog Number #D-257-68086).

9.6.1 To prolong the life of the furnace, increase the voltage to cold furnace slowly.

Chapter 10 Fire Containment Test of Waste Stowage Compartments

10.1 Scope

- 10.1.1 These methods are intended for use in determining the fire containment capability of containers, carts, and compartments used to store combustible waste materials according to the requirements of FAR 25.853(e) through Amendment 51.
- 10.1.2 Parts construction used for the top, bottom, and sides of these compartments must meet the requirements of FAR 25.853 and FAR 25.855. These tests are covered elsewhere in this handbook in chapter 1, Vertical Bunsen Burner Test for Cabin and Cargo Compartment Materials, chapter 2, 45-Degree Bunsen Burner Test for Cargo Compartment Liners and Waste Stowage Compartment Materials, and chapter 4, 60-Degree Bunsen Burner Test for Electrical Wire.
- 10.1.3 There are multiple test arrangements covered in this specification: Entree Carts, Meal Carts, Waste Carts, and Waste Compartment Meal Boxes (see table 10-1 for meal boxes).

Table 10-1. Meal Box Test Arrangements

Equipment Description	Meal Box Stowed in Open Galley Compartment	Enclosed Galley Compartment	Open Cart Compartment	Enclosed Cart Compartment
Metallic meal box, complete enclosure	No test required	No test required	Test meal box within trolley compartment	Test trolley
Metallic meal box, incomplete enclosure	Uncertifiable for waste storage	Test meal box within the compartment	Uncertifiable for waste storage	Test meal box within trolley compartment
Nonmetallic meal box, complete enclosure	Test meal box (unstowed)	Test meal box (unstowed)	Test meal box within trolley compartment	Test trolley compartment with and without meal box
Nonmetallic meal box, incomplete enclosure	Uncertifiable for waste storage	Test meal box/compartment	Uncertifiable for waste storage	Test trolley compartment with and without meal box

10.2 Definitions

10.2.1 Air Ducting

Air ducting is used for conveying chilled air to and from carts.

10.2.2 Waste Cart

An enclosure on wheels that provides a means of accumulating and/or storing waste.

10.2.3 Meal Cart

An enclosure on wheels used to store food and used or unused service trays that might contain waste.

10.2.4 Entree Cart

An enclosure on wheels used to cook or store food at elevated temperatures and transport/store unused or used food service trays that might contain waste.

10.2.5 Integral Floor

The bottom panel of a waste compartment.

10.2.6 Waste Compartment (Galley or Lavatory Module)

An enclosure or shell structure with access provisions, such as a waste chute opening or doors, designed for the purpose of accumulating or storing waste.

10.2.7 Waste Container

A removable receptacle stored within a waste compartment or waste cart designed to accumulate or store waste within the compartment or cart.

10.2.8 Meal Box

A removable enclosure located in a meal trolley or galley compartment used to store food and used or unused service trays that might contain waste.

10.3 Test Apparatus/Equipment

10.3.1 Thermocouple(s)

A thermocouple may be needed to monitor internal test unit temperature.

10.3.1.1 If a thermocouple is used for meal or entree carts, it will be installed 1.5 to 2 inches above the top-most tray. A second thermocouple will be placed on the bottom tray in a similar manner.

10.3.1.2 For waste compartments/carts, a single thermocouple is inserted through the waste flap and placed 1.5 to 2 inches above the waste combustibles surface.

10.3.2 Thermocouple Readout/Recording

If used, thermocouples will be connected to a system that is capable of providing continuous temperature readings. A recording system will be used so that temperatures can be recorded continuously or at intervals not exceeding 15 seconds.

10.3.3 Galley

Galley structure is used to simulate the interface needed for the stowed cart test arrangements.

10.3.3.1 The galley structure will be equipped with power outlets and air inlet/outlet ducting to circulate ambient air at the design-specified airflow to the cart when set up to conduct testing.

10.3.4 Waste Materials

10.3.4.1 Combustibles

10.3.4.1.1 The meal cart arrangement includes the following combustibles:

One set of plastic eating utensils

One cup

One salad dish

One salad dressing container

One entree dish

One dessert dish

One crumpled 2-ply paper napkin, approximately 16 by 16 inches

The trays, each loaded with the above combustibles or equivalent representative materials found in service, will be inserted into the cart so that 75 percent of the trays are loaded in the cart starting from the bottom.

10.3.4.1.2 For the entree cart test arrangement, combustibles will consist of the same items per tray as for the meal cart for the stowed test. For fire source, the bottom tray will have an entree dish half filled with methyl alcohol to simulate grease. The napkin will not be located near the alcohol source. For the unstowed test, treat the entree cart as a meal cart.

10.3.4.1.3 For the waste compartment/waste cart, combustibles will be crumpled and consist of the following proportions of materials or an equivalent:

Eight 2-ply paper and towels, approximately 10 by 11 inches (40 percent by number)

Five 2-ply paper napkins, approximately 16 by 16 inches (25 percent by number)

Four 8-ounce paper hot drink cups (20 percent by number)

Two 3-ounce paper cold drink cups (10 percent by number)

One empty cigarette package (5 percent by number)

The total amount of the above crumpled combustibles in the above proportions will be sufficient to fill the waste compartment or waste container to three-fourths capacity.

10.4 Test Unit

10.4.1 The unit to be tested will be equivalent to an actual production unit, built to drawing specifications and tolerances.

10.4.2 A statement of conformity will be obtained for each test unit prior to testing.

10.5 Test Arrangements

10.5.1 Meal Cart Test Arrangements

10.5.1.1 The unstowed meal cart arrangement requires a condition where the cart is tested in a freestanding position. Photographs (refer to section 10.7.3) will show the door with the chilled air duct interfaces (if applicable).

10.5.1.2 Stowed Meal Cart

The stowed meal cart test arrangement requires the cart be installed in the galley cart compartment with the air inlet/outlet openings connected to the air ducting. During the test, air is to be circulated through the cart at the design flow rate. To simulate the cart/galley interface, photographs of the meal cart should be taken from the side to show the cart vendor. The maximum cart/galley misalignment will be reproduced during the test.

10.5.2 Waste Cart Arrangements

Testing both with and without the waste container is required if the waste container is nonmetallic. The waste cart interface with the galley (i.e., galley waste flap and waste chute) is also required to be simulated if the waste chute enters the cart enclosure and/or keeps the cart waste flap open.

10.5.2.1 An unstowed waste cart (waste container not installed) test arrangement requires a freestanding position at room temperature and still air. Photographs must be taken showing the cart door and flap.

- 10.5.2.2 An unstowed waste cart (waste container installed) test arrangement requires that the cart be in a freestanding position, per section 10.5.2.1, with the waste container installed.
 - 10.5.2.3 A stowed waste cart (waste container not installed) test arrangement requires that the interface of the galley structure with the cart be simulated. The cart will be stowed in a galley mockup that completely simulates the galley/cart interface. Photographs will be taken that clearly show the waste chute/waste cart interface and the cart door during the test.
 - 10.5.2.4 The stowed waste cart (waste container installed) arrangement is equivalent to section 10.5.2.3, except that a waste container is installed.
- 10.5.3 Entree Cart Arrangement
- 10.5.3.1 An unstowed entree cart test arrangement requires that the cart be tested in a freestanding position at room temperature and still air.
 - 10.5.3.2 A stowed entree cart test arrangement requires that the cart be connected to the galley power and, if applicable, air ducting outlets. Power will be supplied to the cart for the duration of the test. All heaters and fans will be switched on with any timers set to the maximum duration. If the cart receives air from the galley ducting when the power is switched off, then a third test (stowed meal cart test arrangement) is required.
- 10.5.4 Waste Compartment Arrangements
- 10.5.4.1 The only condition in which waste compartments without an integral bottom or base panel are to be tested is with the waste container installed within the waste compartment. If a liner is used within the waste container, the test will be conducted both with and without the liner installed. Ambient condition will be room temperature and still air. Photographs will show the compartment door and the waste flap.
 - 10.5.4.2 Waste compartments may be tested without a waste container for waste compartments with an integral floor. If the waste container is nonmetallic, then a waste compartment with an integral floor must be tested both with and without the waste container installed. If a liner is used within the waste container, the test will be conducted both with and without the liner installed.
- 10.5.5 Meal Box Arrangements
- The different types and arrangements of meal boxes that require testing are defined in table 10-1. Meal boxes are to be tested in the same manner as a meal cart (see section 10.6.1).

10.6 Procedure

10.6.1 Ignition

10.6.1.1 Meal Cart

10.6.1.1.1 Stowed Meal Cart Test Arrangement

Ignite two crumpled 2-ply paper napkins, approximately 16 by 16 inches in size. Place them side by side adjacent to the combustibles, defined in section 10.3.4, already in place on the bottom tray the greatest possible distance from the air inlet/outlet openings of the cart. Allow a good flame front to develop by allowing approximately 50 percent of the surface of the waste materials to ignite. Insert the tray into the cart, record the temperature, and close the door. Place the cart into the simulated galley structure so that it is connected with the galley duct/cart interface. The airflow through the cart will be at the design airflow rate.

10.6.1.1.2 Unstowed Meal Cart Test Arrangement

Ignite two crumpled 2-ply paper napkins, approximately 16 by 16 inches in size. Place them side by side adjacent to the other combustibles, defined in section 10.3.4, already on the bottom tray. Allow a good flame front to develop by allowing approximately 50 percent of the surface of the waste materials to ignite. Insert the tray into the cart and simultaneously close the door and record the temperature, if the temperature is being monitored.

10.6.1.2 Entree Cart

10.6.1.2.1 Stowed Entree Cart

Connect the entree cart filled with the combustibles of section 10.3.4.1.2 to the power source and energize all heaters and/or fans. Ignite the methyl alcohol in the entree dish on the bottom tray by placing a burning napkin onto the tray. Insert the tray into the cart, close the cart door, and simultaneously record the temperature, if the temperature is being monitored.

10.6.1.2.2 Unstowed Entree Cart

Proceed per the unstowed meal cart test configuration of section 10.6.1.1.2.

10.6.1.3 Waste Cart

10.6.1.3.1 Stowed Waste Cart With Waste Container

Ignite a paper napkin and place it in the waste container through the waste flap. Allow a good flame front to develop by allowing 50 percent of the surface of the waste materials to ignite. Close the waste flap and simultaneously record the starting temperature.

10.6.1.3.2 Stowed Waste Cart Without Waste Container

Proceed per section 10.6.1.3.1, except that no waste container is used.

10.6.1.3.3 Unstowed Waste Cart With Waste Container

Proceed per section 10.6.1.3.1.

10.6.1.3.4 Unstowed Waste Cart Without Waste Container

Proceed per section 10.6.1.3.2.

10.6.1.4 For the waste compartment with and without waste container, proceed per applicable waste can arrangement, sections 10.6.1.3.1 and 10.6.1.3.2.

10.6.1.5 For the meal box, proceed per section 10.6.1.1.

10.6.2 Temperature

If the temperature is being monitored, it will rise rapidly, peak, and then fall below 150°F (66°C) as the flame dies out. The peak in temperature is necessary to identify that combustion has taken place. An example of this temperature peak is visualized in the temperature versus time plot shown in figure 10-1. When the temperature indicated by the thermocouple falls below 150°F (66°C), the test is terminated and the item examined for damage. If a suitable temperature peak above 150°F (66°C) is not obtained after three trials, sufficient ventilation will be provided to achieve a peak.

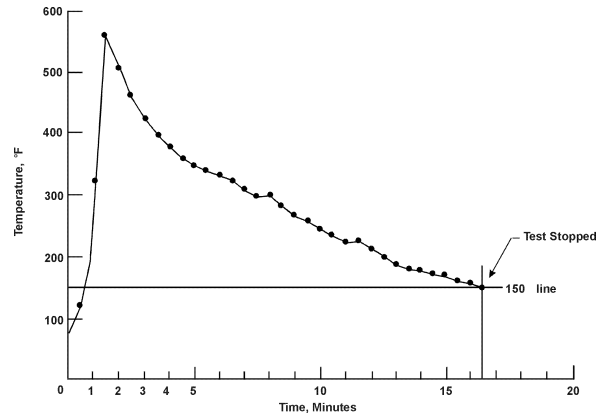

Figure 10-1. Sample Fire Containment Temperature versus Time Plot

10.6.3 Photographs

Photographs, preferably in color, are required to document the progress of the test. Suggested photographs that may be taken include the test unit before test, test setup, at time of ignition (with door or flap enclosed), at 30 seconds, 1 minute, 2 minutes, 3 minutes, 5 minutes, 7 minutes, and 10 minutes into the test, and at 5-minute intervals thereafter. Include detailed photographs showing any damage sustained as a result of the fire. Photographs taken during the test shall have a dark background to show smoke in contrast.

10.6.4 Inspection

After the test has been terminated, the test unit will be inspected for damage. The doors will be opened and the extent of combustion of the waste materials will be noted. Photographs will be taken of these waste materials and any damage to the cart or compartment, or lack of damage. Care should be taken to completely document any damage, from simple smoke stains and melting of trays to major burnthrough of any panels.

10.7 Report

10.7.1 Identification of Specimen

Completely identify the unit being tested and its intended use.

10.7.2 Description

The results of the test will be described in a concise manner regarding any observable smoke or fire from within the item. Any deterioration, burnthrough, or deformation of the panels caused by heat or flame will be noted and described along with the time of occurrence. Any damage to the item and/or surrounding structures during the test will be noted. Any damage to the contents will be described, including the degree of combustion of the articles placed within the unit, and damage to trays, seals, etc.

10.7.3 Temperature Versus Time Plot

A temperature versus time plot may be supplied in the report if temperature is monitored during the test. An example of a temperature versus time plot is shown in figure 10-1.

10.7.4 Test Photographs

The photographs taken (per section 10.6.3) of the test method will be included with the report. Photocopies of photographs are not acceptable. A short description will accompany each photograph.

10.7.5 Acceptance of Results

A statement as to whether the acceptance criteria are met will be made in the report.

10.7.6 Statement of Conformity

The statement of conformity sheet will be included with the test report.

10.7.7 Summary of Data

A summary may be prepared and included with the test report.

10.8 Requirements

- 10.8.1 The temperature indicated by the thermocouple(s), if used, after ignition will rise rapidly, peak, and then fall steadily as the fire burns out. To be valid, the test will have a definitive peak to demonstrate that a fire has taken place. If no peak is visible or a good flame front cannot be achieved, the test will be repeated up to three times to demonstrate that sufficient effort has been made to produce such a temperature peak or flame front.
- 10.8.2 The test unit will be able to contain a fire within the enclosure.
- 10.8.3 Fire/flame will not penetrate through or issue from the bottom, top, or sides of the waste compartment/container, and adjacent material will not be ignited by heat from the test article.
- 10.8.4 Smoke will be contained within the waste compartment/container to the extent that the smoke level produced in the cabin does not create a hazardous condition or interfere with firefighting procedures.

Chapter 10 Supplement

This supplement contains advisory material pertinent to referenced paragraphs.

10.2.5 An integral floor is part of the galley/cart waste compartment. It is not the aircraft floor panel.

10.5.1 Misalignment generally refers to maximum air gaps, maximum seal interfaces, minimum overlaps, etc., allowed by drawing tolerances. Misalignment must be simulated during testing because with repeated waste receptacle handling, seals are unlikely to remain airtight. Misalignment may be represented during the test by using a 3/4-inch-long shim to support the door opening representing the allowable tolerance in the design drawings.

Chapter 11 Powerplant Hose Assemblies Test

11.1 Scope

- 11.1.1 This test method is used to determine the fire resistance of high-temperature hose assemblies used in designated fire zones to damage due to flame and vibration for showing compliance with TSO C42, C53A, and C75.
- 11.1.2 The requirements and procedures of this test method vary according to hose materials and hose assembly application.

11.2 Definitions

11.2.1 Designated Fire Zone

A designated fire zone is defined as a region of the aircraft, such as engine and auxiliary power unit compartments designated to require fire detection and extinguishing equipment, and as appropriate, the use of materials that are fire resistant or fireproof.

11.2.2 Fireproof

Per FAR Part 1, (found in Subchapter A—Definitions, Part I—Definitions and Abbreviations) “in designated fire zones means the ability of materials to withstand the heat from a severe fire of extended duration at least as well as steel in dimensions appropriate for their purpose.”

Powerplant hose assemblies are demonstrated to be fireproof by meeting the requirements of this test for a flame exposure time of 15 minutes.

11.2.3 Fire Resistant

Per FAR Part 1, (found in Subchapter A—Definitions, Part I—Definitions and Abbreviations) “with respect to fluid carrying lines, fluid system parts, wiring, air ducts, fittings, and powerplant controls means the capacity to perform the intended functions under the heat and other conditions likely to occur when there is a fire at the place concerned.”

Powerplant hose assemblies are demonstrated to be fire resistant by meeting the requirements of this test for a flame exposure time of 5 minutes.

11.2.4 Class A Hose Assembly

A class A hose assembly is defined as a hose assembly capable of withstanding exposure to this fire test procedure for 5 minutes without failure (e.g., leaking circulating oil) per TSO C53a.

11.2.5 Class B Hose Assembly

A class B hose assembly is defined as a hose assembly capable of withstanding exposure to this fire test procedure for 15 minutes without failure (e.g., leaking circulating oil) per TSO C53a.

11.2.6 Velometer

A device for measuring airflow velocity.

11.2.7 Photocell

An electronic device having output that varies in response to the intensity of incident visible light.

11.3 Apparatus

11.3.1 Test Burner

A modified gun-type conversion oil burner as described in table 11-1 will be used. The burner will be calibrated to provide a minimum average flame temperature of 2,000°F (1,100°C) and a minimum

Table 11-1. Test Burner Information

Burner Standard Model Designation	Power Supply	Test Nozzle	Test Fuel Flow	Test Air Pressure in Draft Tube (ref)	Modifications to Standard Burner
Stewart Warner HPR-250 This burner is no longer available. Supplier Stewart-Warner Corp. Heating & Air Conditioning Lebanon, Indiana 46052	1/4 HP/115V/ 60Hz/single ph	2.25 gal/hr 80-degree angle	2 gal/hr (95-psig pump press ref)	0.14 in H ₂ O	<ol style="list-style-type: none"> 1. Air tube diameter reduced to 2.5 inches (63.5 mm), starting 1.5 inches (38 mm) forward of nozzle tip. 2. Added four 3/4- by 1/16-inch (19- by 1.59-mm) stainless steel fuel deflectors mounted on the reducing cone at 3, 6, 9, and 12 o'clock. The deflector edges were 3.4 inches (19 mm) off center line (CL) and 3.4 inches (19 mm) forward of fuel nozzle up. 3. Added static air pressure port 1 inch (25.4 mm) forward of the burner tube mounting flange. 4. Added a 12.5 inch (317.5 mm) burner extension so that the wide end is 10 inches (254 mm) beyond the end of the air tube.
Stewart Warner FR-600 This burner is no longer available. Supplier Stewart-Warner Corp. Heating & Air Conditioning Lebanon, Indiana 46052	1/3 HP/115V/ 60Hz/single ph	Same as above	2 gal/hr (100-psig pump press ref)	0.01 in H ₂ O	<ol style="list-style-type: none"> 1. Air tube diameter reduced to 2.5 inches (63.5 mm), starting 1.5 inches (38 mm) forward of nozzle tip. 2. Added four 3/4- by 1/16-inch (19- by 1.59-mm) stainless steel fuel deflectors mounted on the reducing cone at 3, 6, 9, and 12 o'clock. The deflector edges were 3.4 inches (19 mm) off CL and 3.4 inches (19 mm) forward of fuel nozzle up. 3. Added static air pressure port 1 inch (25.4 mm) forward of the burner tube mounting flange. 4. Added a 12.5-inch (317.5-mm) burner extension so that the wide end is 10 inches (254 mm) beyond the end of the air tube.
Lennox OB-32 (This is now obsolete and cannot be purchased.)		2.25 gal/hr 80-degree angle	2 gal/hr (80-psig pump press ref)	0.17 in H ₂ O	<ol style="list-style-type: none"> 1. Add a 12.5-inch (317.5 mm) burner extension.

Table 11-1. Test Burner Information—(Continued)

Burner Standard Model Designation	Power Supply	Test Nozzle	Test Fuel Flow	Test Air Pressure in Draft Tube (ref)	Modifications to Standard Burner
Carlin 200CRD This burner is not available with modifications. Supplier Carlin Co. 912 Silas Dean Hwy Wethersfield, Conn. 06109	1/4 HP/115V/ 60Hz/single ph	Same as above	2 gal/hr (97-lb/in ² pump press ref)	0.37 in H ₂ O	<ol style="list-style-type: none"> 1. Disassemble the burner air tube assembly and remove the throttle ring and the retention ring. 2. Remove the existing fuel nozzle and install an 80-degree, 2.25-gal/hr nozzle. After reassembly, adjust the OD delivery rate to 2.01 gal/hr at 97 lb/in² gauge. 3. Using 1/16 inch stainless steel material, manufacture and install three deflectors. 4. Manufacture a flat-disk plate to match the inside diameter of the burner air tube and randomly punch 10 1/2-inch holes as shown. The main purpose of this disk is to center the oil delivery tube. Locate and punch holes for the ignitors and the oil delivery tube. A pie-shaped segment was cut out for ease of installation and the split-baffle mounting bracket was secured to the oil delivery tube with a small hose clamp. Position this flat-disk plate 4 inches aft of the fuel nozzle. 5. Manufacture and install a reducing cone. The outside diameter of this cone should match the inside diameter of the oil burner air tube. This cone is secured in place with small Allen or socket head screws. 6. Install the static pressure port 1 inch forward of the air tube mounting flange and adjust the air pressure in the air tube to approximately 0.37 inch of H₂O during operation. 7. Manufacture a 12 1/2-inch burner air tube extension and install this extension so that the wide end is 10 inches beyond the end of the burner air tube.

Table 11-1. Test Burner Information—(Continued)

Burner Standard Model Designation	Power Supply	Test Nozzle	Test Fuel Flow -0, +0.05 gal/hr	Test Air Pressure in Draft Tube (ref)	Modifications to Standard Burner
Park DPL 3400 Supplier Park Manufacturing Company New York and Absecon Blvd. Atlantic City, New Jersey 08401					This burner will be built to the FAA's specifications upon request.

heat input of 4,500 Btu/hr to the Btu heat transfer device described in section 11.3.3.2, or 9.3 Btu/ft²-sec (10.6 W/cm²) as measured by a calorimeter described in section 11.3.3.1.

11.3.1.1 Burner Extension

A stainless steel funnel extension, fabricated in accordance with figure 11-1, will be used. The funnel will have an oblong exit 6 inches (152 mm) high by 11 inches (279 mm) wide. The funnel will be installed on the burner with the air tube shown in figure 11-2.

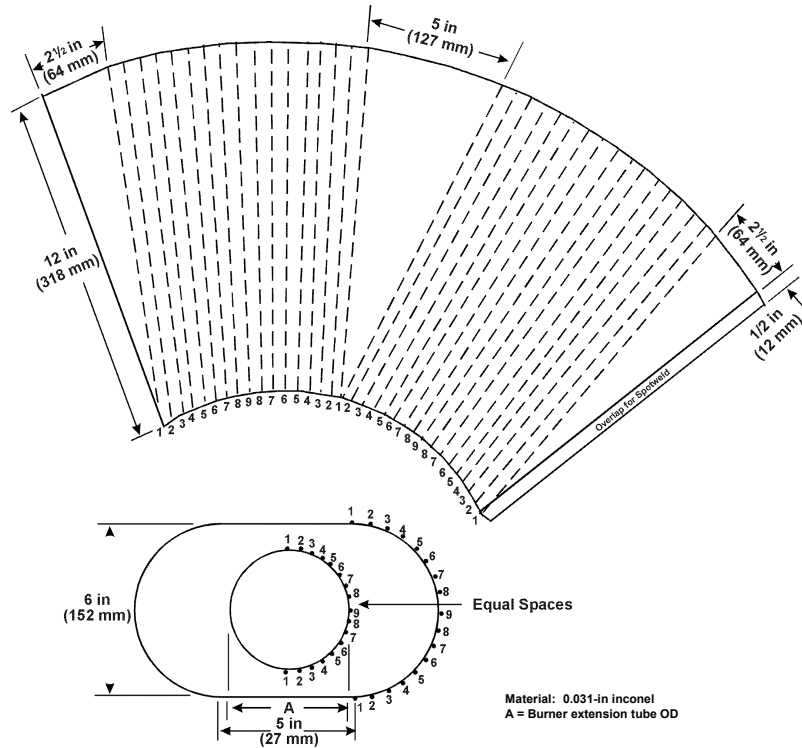

Figure 11-1. Burner Extension Funnel

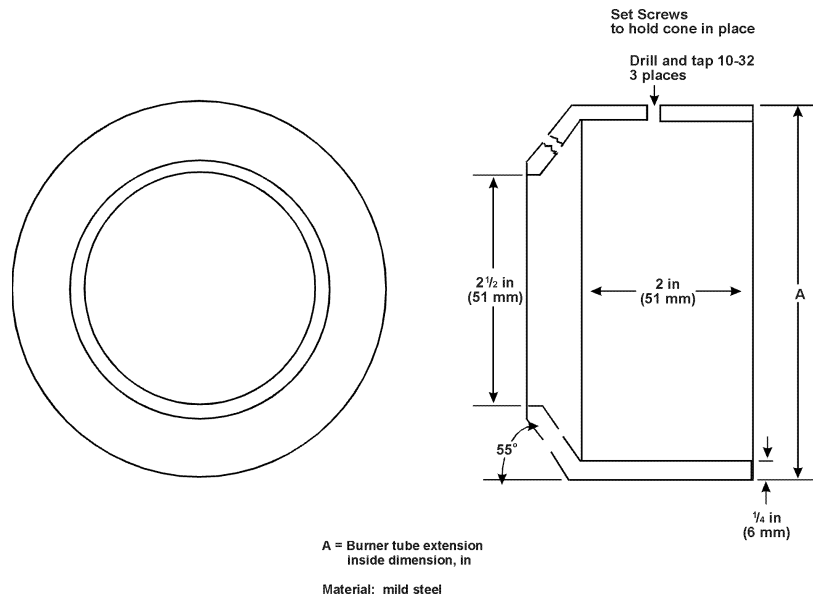

Figure 11-2. Air Tube Reducing Cone

11.3.1.2 Burner Fuel

Society of Automotive Engineers (SAE) No. 2 diesel, kerosene, or equivalent will be used for burner fuel.

11.3.2 Thermocouples

A thermocouple rake containing at least five American National Standard Institute (ANSI) 22-gauge Chromel-Alumel (Type K) thermocouple sheathed in 1/16-inch (1.6-mm) -thick stainless steel or inconel tubes, or equivalent, will be provided. The thermocouples will be aligned in a row 1 ± 0.1 inch (25 ± 3 mm) apart.

11.3.3 Heat Flux Measuring Device

One of the following devices will be used to measure the heat flux density of the flame.

11.3.3.1 Calorimeter

A water-cooled calorimeter capable of measuring heat flux densities up to $15 \text{ Btu/ft}^2\text{-sec}$ (17 W/cm^2) may be provided for burner calibration. A Hy-Cal model 1300A total heat flux density calorimeter available from Hy-Cal Engineering, Santa Fe Springs, California, or equivalent has been found suitable.

11.3.3.2 Btu Heat Transfer Device

Figures 11-4 to 11-10 show fabrication details of an acceptable copper tube device used to measure heat flux density. The mercury thermometers will be positioned in the mounting tubes so that the bottom of the bulb is within 1/16 inch (1.6 mm) of the bottom of the passage in the heat transfer tube (see figures 11-7 and 11-8).

11.3.3.2.1 Thermometers

Two glass scientific thermometers calibrated in 0.05°C (0.1°F) increments, immersible thermocouples, or equivalent will be provided for the heat transfer tube assembly.

11.3.4 Test Setup

A steel table measuring 60 inches (1,524 mm) wide, 28 inches (711 mm) deep, and 32 inches (813 mm) high has been found acceptable. The vibrating mechanism and hood, described below, may be mounted on this table. See figure 11-1 for an acceptable test setup.

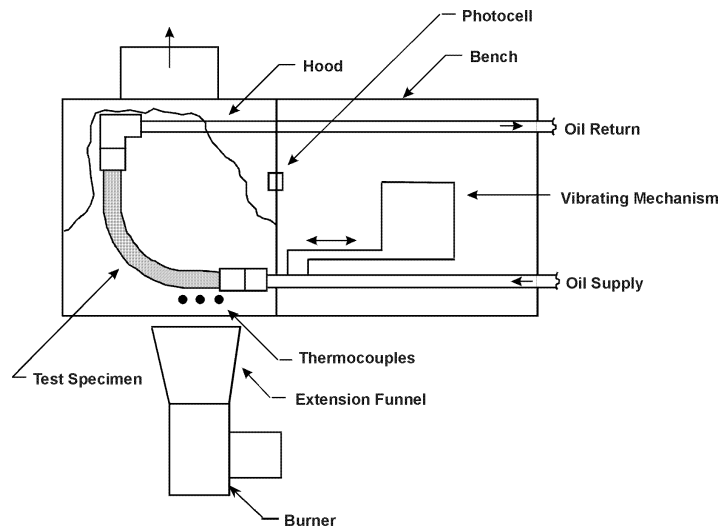

Figure 11-3. Hose Assemblies Test Setup

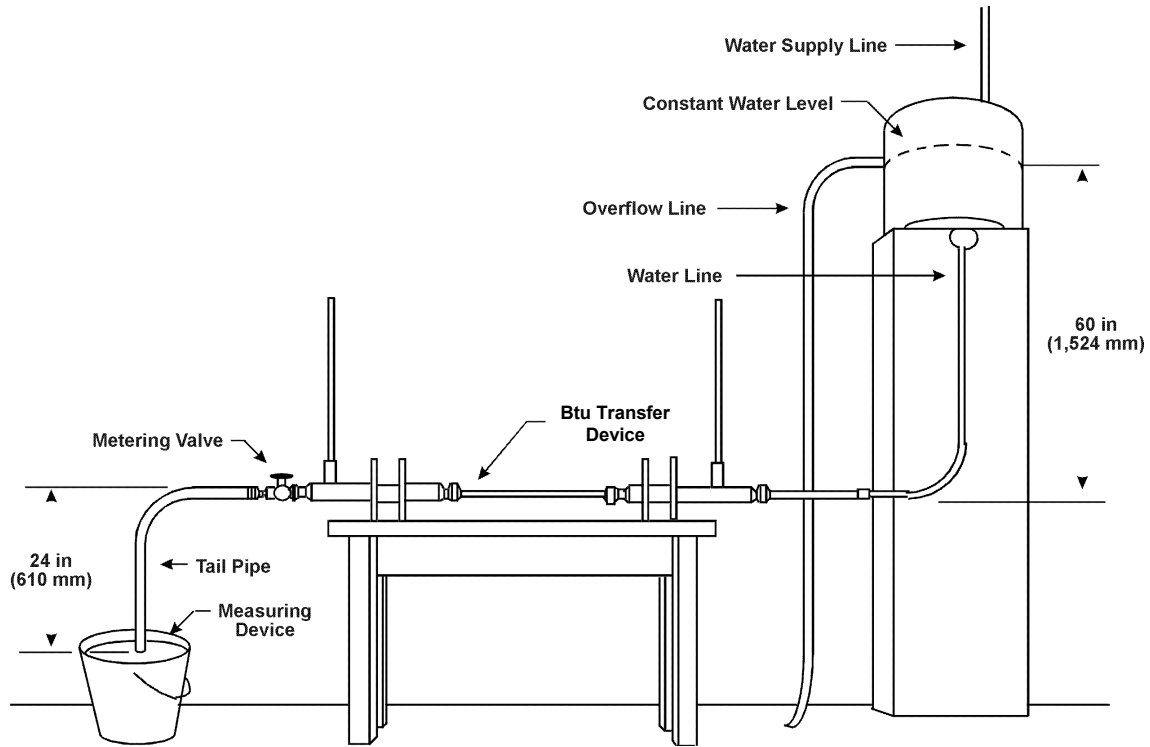

Figure 11-4. Burner Calibration Standardization Apparatus

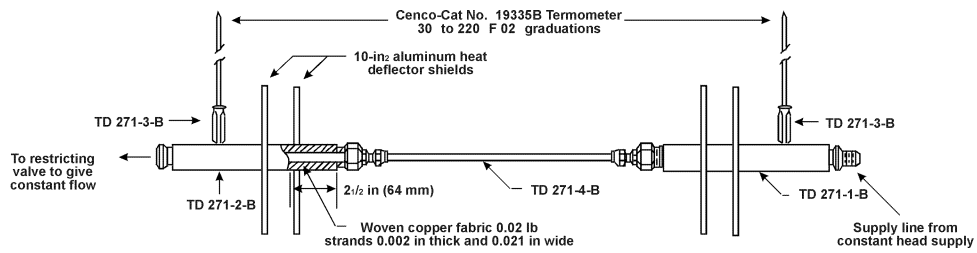

Figure 11-5. Btu Heat Transfer Device

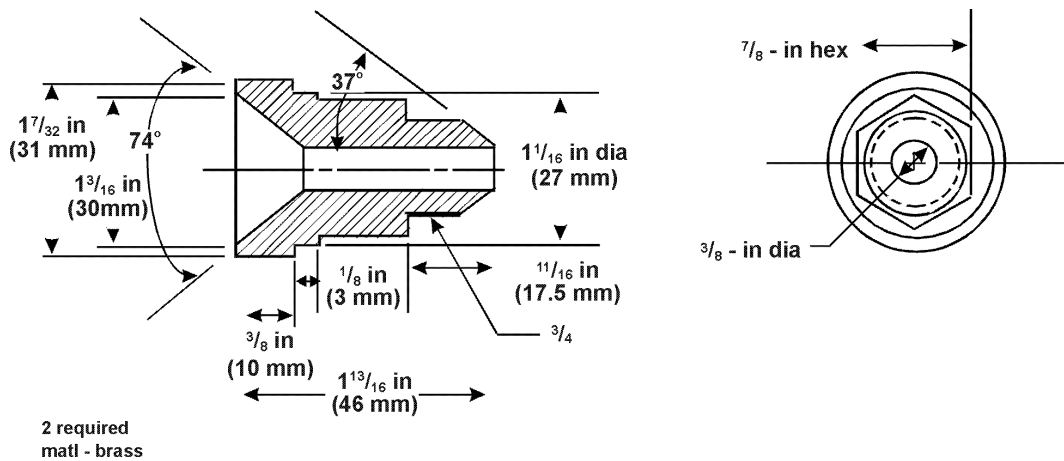

Figure 11-6. Btu Heat Transfer Device—Reducer

Material
 (Alternate material may be used provided
 thermal conductance is equivalent)
 1 7/16 -in OD x 1 3/16 -in ID x 12 in

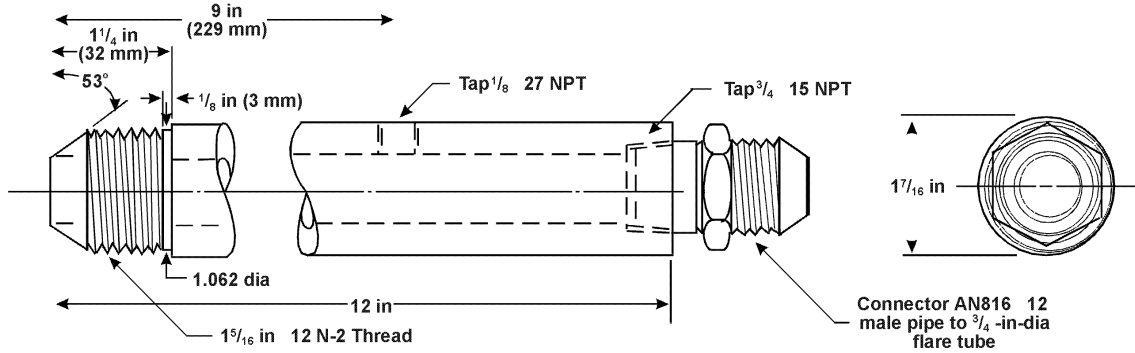

Figure 11-7. Btu Heat Transfer Device—Inlet Tube

Material—Transit Asbestos-Based Tubing
 (Alternate material may be used provided
 thermal conductance is equivalent)
 1 7/16 -in OD x 1 3/16 -in ID x 12 in

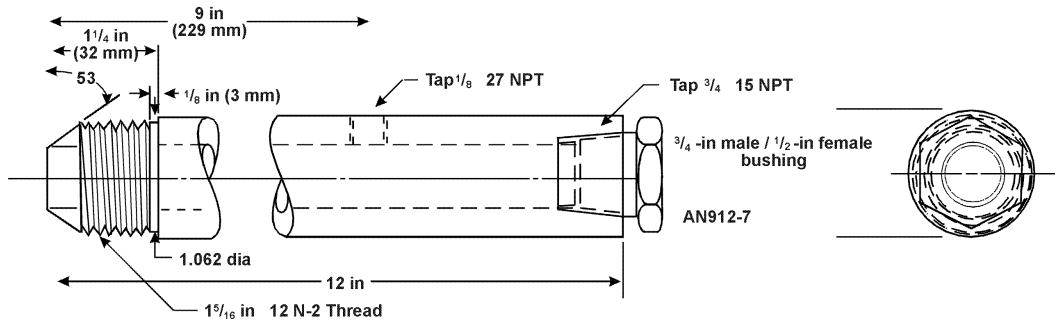

Figure 11-8. Btu Heat Transfer Device—Outlet Tube

Two required
Material: brass, 9/16 -in hex x 3 3/4 in

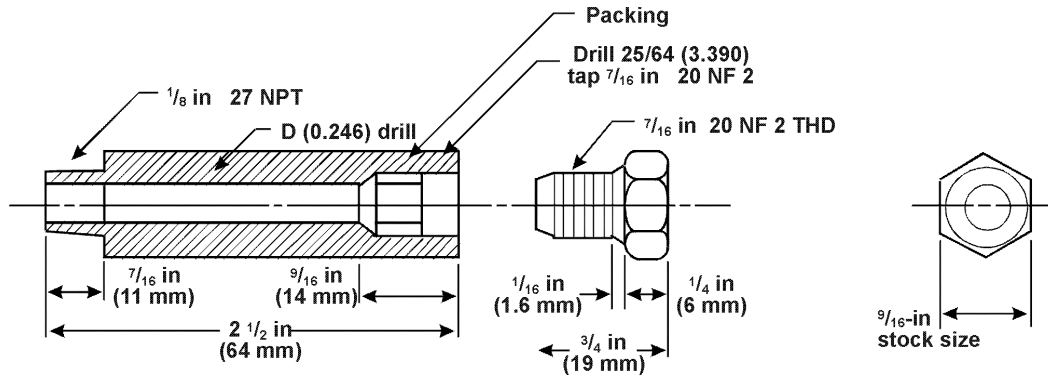

Figure 11-9. Btu Heat Transfer Device—Thermometer Mounting

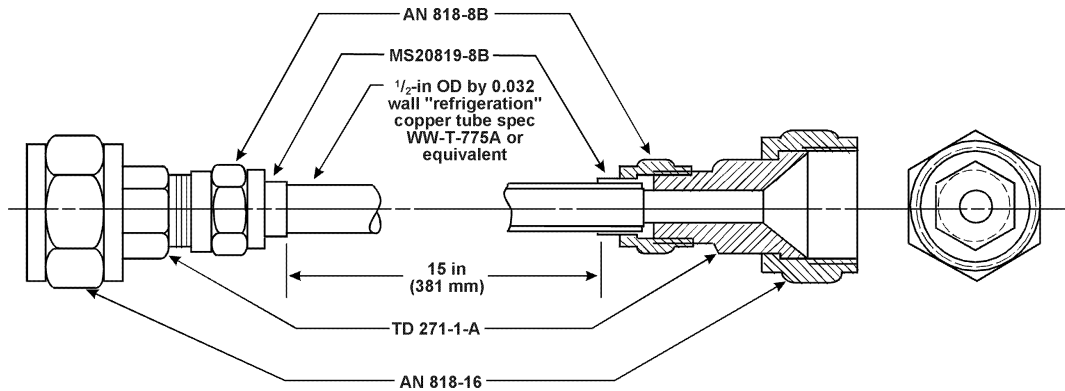

Figure 11-10. Btu Heat Transfer Device—Test Specimen

11.3.4.1 Vibration Source

A means will be provided to vibrate the hose assembly as shown in figure 11-8 at 33 Hz with a total displacement of a least 1/8 inch (3.2 mm), i.e., with an amplitude of at least 1/16 inch (1.6 mm).

11.3.4.2 Hood

A hood measuring 25 inches (635 mm) wide and 25 inches (635 mm) high has been found acceptable. The hood may be placed on the bench near the vibration source so that the vibrating fitting for the hose attachment is located 7 inches (178 mm) behind the open front of the hood.

11.3.4.2.1 Fan

The hood will have a fan installed on the rear to draw air through it at a velocity of 400 ft/min (203 cm/s), as measured by a velometer located at the position occupied by the hose assembly specimen during the test.

11.3.4.2.2 Photocell

The hood may contain a photocell to detect a flareup resulting from burning oil due to a hose failure.

11.3.4.3 Automatic Shutdown System

If a flareup of burning oil escaping from a failed hose assembly is detected, an automatic shutdown system may be provided to terminate the test by turning off the burner, vibrating mechanism, hood fan, and oil flow.

11.3.4.4 Temperature Measuring and Recording Equipment

A temperature sensing system will be provided that includes a sufficient number of thermocouples to ensure that the specified temperature exists along the entire end fitting and along the hose for a distance of not less than 5 inches (127 mm). The system will include a recorder to monitor the flame temperature throughout the fire test duration.

11.3.5 Oil Circulator and Heater

A device consisting of an oil tank with a temperature-controlled immersion heater and an electric oil pump will be provided if the hose assembly being tested must have oil pumped through the hose(s) during the test. The plumbing will include appropriate flow indicators, pressure gauges, control and selector valves, and pressure relief valves.

11.3.5.1 Oil

SAE No. 20 oil, in accordance with Military Specification MIL-L-2104C or equivalent, will be provided and used in the oil circulator and heater to pump through the hose assembly test specimen during the test.

11.4 Test Specimens

- 11.4.1 Prepare three specimens, 24 inches (610 mm) long, for the test.
- 11.4.2 The configuration of the hose test specimens will be as used in service. A firesleeve may be added to the hose assembly, if needed, to enable the test specimens to withstand the fire test duration specified.

11.5 Calibration

- 11.5.1 Place the thermocouple rake on the test stand at a distance 4 inches (102 mm) above the centerline of the burner extension. Connect the thermocouples to a stripchart recorder.
- 11.5.2 Light the burner, allow a 3-minute warmup, and move the burner into test position.
- 11.5.3 Begin monitoring the temperatures indicated by the thermocouples after 3 minutes. Make adjustments as necessary to either the gas flow or the airflow to the burner in order to achieve a minimum average thermocouple reading of 2,000°F (1,100°C).
- 11.5.4 Turn the burner off, move it out of test position, and remove the thermocouple rake.
- 11.5.5 Replace the thermocouple rake with the heat flux measuring device. Follow section 11.5.5.1 if using a water-cooled calorimeter for measuring heat flux. Follow section 11.5.5.2 if using a Btu heat transfer device for this purpose.
 - 11.5.5.1 If using the water-cooled calorimeter described in section 11.3.3.1, place the calorimeter at the same distance as the thermocouple rake centered over the burner exit.
 - 11.5.5.1.1 Light the burner, allow a 2-minute warmup, and move the burner into test position.
 - 11.5.5.1.2 Measure the heat flux density continuously or at intervals no greater than 10 seconds. If the heat flux density is not at least 9.3 Btu/ft²-sec (10.6 W/cm²), readjust the burner to achieve the proper heat flux. If burner adjustments are necessary, remove the heat flux measuring device and repeat sections 11.5.1 through 11.5.5.1.2.
 - 11.5.5.2 If using the Btu heat transfer device described in section 11.3.3.2, ensure the external surface of the copper tubing on the Btu heat transfer device is clean prior to measuring heat flux. Use fine steel wool to clean the copper tubing. Inspect the tubing bore for corrosion and/or scale accumulation and remove before each test. A .45-caliber pistol cleaning brush, or equivalent, with an extension has been found suitable for this purpose.
 - 11.5.5.2.1 The calibration setup is shown in figure 11-3. Provide a 5-foot (1.5 m) constant head of water above the heat transfer device and a 2-foot (0.61 m) drop to the end of the tailpipe for adjustment of the water flow rate. Use a 1 gallon (3.8 L) measuring container (a container and a weighing scale are also acceptable). Adjust the water flow rate to 500 lb/hr (227 kg/hr) or 1 gal/min (3.8 L/min). Supply water at a temperature of 50 to 70°F (10 to 21°C).
 - 11.5.5.2.2 Start the water flowing through the Btu heat transfer device. Center the heat transfer tube in the flame at the same location that a hose assembly would be placed for testing. Allow a 2-minute warmup period to stabilize flame conditions before temperature measurements from the mercury thermometers are recorded.

- 11.5.5.2.3 After the warmup period, record the inlet and outlet temperatures every 30 seconds for a 3-minute period. Determine the rate of Btu increase of the water as follows:

$$\begin{aligned} \text{Heat transfer} &= 146 \times (T_o - T_i) \text{ watts (for Celsius)} \\ &= 500 \times (T_o - T_i) \text{ Btu/hr (for Fahrenheit)} \end{aligned}$$

where: T_o = temperature ($^{\circ}\text{C}$ or $^{\circ}\text{F}$) at outlet

T_i = temperature ($^{\circ}\text{C}$ or $^{\circ}\text{F}$) at inlet

- 11.5.5.2.4 The heat rate output, as determined by the equation shown in section 11.5.5.2.3, will be a minimum of 4,500 Btu's per hour. If the heat output from the burner is not above this minimum, make adjustments to the burner and repeat sections 11.5.1 through 11.5.2 until the burner is within tolerance.

11.6 Procedure

11.6.1 Specimen Mounting

Mount the hose assembly in the test setup to include at least one full 90-degree bend so that the pressure existing inside the hose will exert an axial force on the hose end fitting. Locate the hose assembly 4 inches (102 mm) beyond the burner barrel extension so that the entire hose assembly end fitting and at least a minimum 5 inches (127 mm) of the hose is exposed to the flame. Install the entire hose assembly inside the hood unless limited by the physical characteristics of the hose such as minimum bend radius (see figure 11-1).

- 11.6.2 Preheat the oil in the oil tank to $200^{\circ} \pm 10^{\circ}\text{F}$ ($93^{\circ} \pm 6^{\circ}\text{C}$). Start the oil circulating pump and circulate the oil through the test hose assembly at a flow rate and pressure as specified by hose type, size, and application. Pressures and flow rates are as shown in table 11-2.

Table 11-2. Circulating Oil Pressure and Flow Rate

Hose Type	Circulating Oil		
	Pressure	Flow Rate	
		GPM	L/min
1a	System Working	$5 \times \text{ID (in)}^2$	$0.03 \times \text{ID (mm)}^2$
1b	System Working	$1 \times \text{ID (in)}^2$	$0.006 \times \text{ID (mm)}^2$
11a	System Working	$5 \times \text{ID (in)}^2$	$0.03 \times \text{ID (mm)}^2$
11b	System Working	$1 \times \text{ID (in)}^2$	$0.006 \times \text{ID (mm)}^2$

- 11.6.3 Start the vibrating mechanism and observe the movement of the hose. Ensure that no whipping of the hose occurs.
- 11.6.4 Start the hood air fan and begin monitoring the thermocouple recorder.
- 11.6.5 Start the burner. Periodically observe the recorded temperature to ensure that the required minimum flame temperature of $2,000^{\circ}\text{F}$ ($1,093^{\circ}\text{C}$) is maintained.
- 11.6.6 If a flareup of burning oil occurs due to a hose failure, terminate the test.
- 11.6.7 After the required test duration has been reached (i.e., 5 minutes for class A hose assemblies and 15 minutes for class B hose assemblies), terminate the test.
- 11.6.7.1 Stop the burner.
- 11.6.7.2 Relieve the oil pressure in the hose assembly.
- 11.6.7.3 Turn off the temperature recorder.

11.7 Report

- 11.7.1 Fully identify the hose configuration, including the assembly and fittings, and the class for which it is being tested.
- 11.7.2 Report if there were any flareups of leaking oil and any other pertinent observations.
- 11.7.3 Report whether the hose configuration met the requirements of class A or class B assemblies.

11.8 Requirements

11.8.1 Class A Hose Assembly

A class A assembly will withstand the test procedure in section 6 for at least 5 minutes without leaking circulating oil.

11.8.2 Class B Hose Assembly

A class B hose assembly will withstand the test procedure described in section 6 for at least 5 minutes without leaking circulating oil.

Chapter 11 Supplement

This supplement contains advisory material pertinent to referenced paragraphs.

11.2.6 A velometer manufactured by Alnor Instrument Company, 7555 North Linder Avenue, Skokie, Illinois 60077-3822, catalog number 01518, has been found satisfactory.

11.3.3.2 A satisfactory version of the woven copper fabric shown in figure 11-5 is manufactured by Metal Textile Corporation, Roselle, New Jersey.

11.3.4.4 Permanent installation of temperature measuring thermocouples and continuous recorder has been added for better control of the flame temperature during calibration and test.

11.4.2 If a firesleeve is required to be added for a hose type to pass the test, a firesleeve must be fitted to that hose type before it can be used in designated fire zones on an airplane.

11.6.2 Flow rate values given in table 11-2 were derived from the most recent TSO C53. Flow rates used for the test will be minimum flow rates given for the actual installation, if known.

Chapter 12 Powerplant Fire Penetration Test

12.1 Scope

- 12.1.1 This test method is intended to determine the capability of components and constructions to control the passage of fire or its effects in powerplant (engine) compartments and, thereby, to prevent additional hazard to the aircraft.
- 12.1.2 This test is used to show compliance with FARs 25.867, 25.865, 25.1191, and 25.1193.

12.2 Definitions

12.2.1 Firewall

A firewall is a structure designed to prevent a hazardous quantity of air, fluid, or flame from exiting a fire zone in which a fire has erupted and causing hazard to the aircraft. Firewalls must be fireproof.

12.2.2 Fireproof

Per FAR Part 1, (found in Subchapter A—Definitions, Part I—Definitions and Abbreviations) “in designated fire zones means the ability of materials or parts to withstand the heat from a severe fire of extended duration at least as well as steel in dimensions appropriate for their purpose.”

12.2.2.1 Materials or parts are demonstrated to be fireproof by meeting requirements of this test for a flame exposure of 15 minutes.

12.2.3 Fire Resistant

Per FAR Part 1, (found in Subchapter A—Definitions, Part I—Definitions and Abbreviations) “with respect to fluid carrying lines, fluid system parts, wiring, air ducts, fittings, and powerplant controls means the capacity to perform the intended functions under the heat and other conditions likely to occur when there is a fire at the place concerned.”

12.2.3.1 Materials or parts are demonstrated to be fire resistant by meeting the requirements of this test for a flame exposure of 5 minutes.

12.2.4 Heat Flux Density

The rate of thermal energy transferred per unit area, expressed here in units of Btu/ft²-sec or W/cm².

12.3 Apparatus

12.3.1 Test Burner

The burner will be a modified gun-type oil burner, such as Part Model DPL 3400, Stewart Warner HPR-250 or FR 600, Lennox OB-32, or Carlin 200 CRD. The burner will be calibrated to provide a minimum average flame temperature of 2,000°F (1,093°C) and a minimum heat transfer rate of 4,500 Btu/hr to the Btu heat transfer device described in chapter 11, section 11.3.3.2, or 9.3 Btu/ft²-sec (10.6 W/cm²) as measured by a calorimeter described in section 11.3.3.1.

12.3.1.1 Burner Extension

A stainless steel funnel extension fabricated in accordance with figure 11-1 will be used. The funnel will have an oblong exit 6 inches (152 mm) high by 11 inches (279 mm) wide. The funnel will be installed on the burner with the air tube shown in figure 11-2.

12.3.1.2 Burner Fuel

SAE No. 2 diesel, kerosene, or equivalent will be used for burner fuel.

12.3.2 Thermocouples

A thermocouple rake containing at least five ANSI 22-gauge Chromel-Alumel (Type K) thermocouples sheathed in 1/16 inch (1.6 mm) stainless steel or inconel tubes or equivalent will be provided. The thermocouples will be aligned in a row, 1.0 ± 0.1 inch (25 ± 2 mm) apart.

12.3.3 Heating Rate Measuring Devices

One of the following devices will be used to measure the heating rate of the flame.

12.3.3.1 Btu Heat Transfer Device

A Btu heat transfer device described in Chapter 11, "Power Plant Hose Assemblies Test," figures 11-5 to 11-10, in this handbook may be used.

12.3.3.2 Calorimeter

A calorimeter capable of measuring heat flux densities up to 15 Btu/ft-sec (17 W/cm) may be used. A Hy-Cal model 1300A total heat flux density calorimeter available from Hy-Cal Engineering, Santa Fe Springs, California, or equivalent with water cooling has been found suitable.

12.3.4 Test Stand

A test stand will be provided to maintain the position of the thermocouple rake, calorimeter, or Btu heat transfer device, and test specimen. The test stand will include a provision for either moving the burner out of the test position or moving the test specimen into/out of test position. The test stand will also include a provision for positioning the thermocouple rake or burner extension parallel to the burner face with the thermocouple junctions on the diameter or major axis of the burner extension. A suitable test setup is shown in figure 12-1.

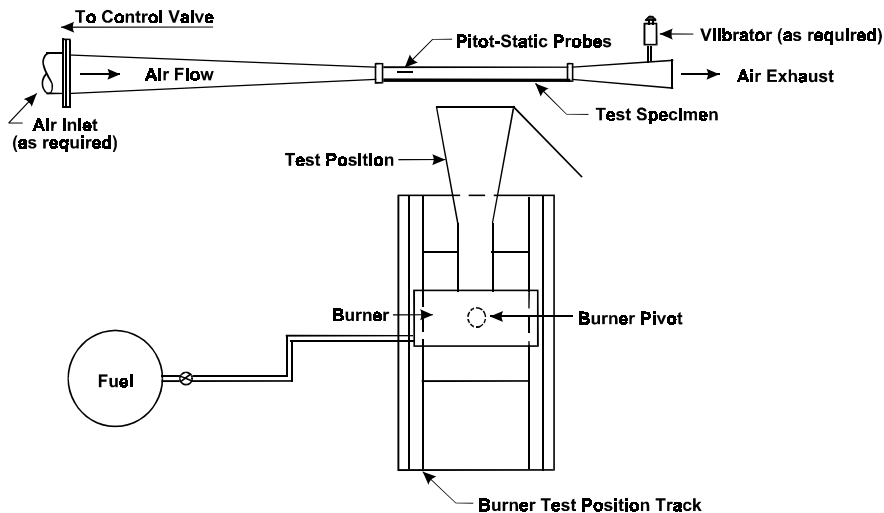

Figure 12-1. Firewall Penetration Test Setup—Top View

12.3.5 Timer

A stopwatch or other device, calibrated and graduated to the nearest 1 second, will be used to measure the time of application of the burner flame.

12.4 Test Specimens

12.4.1 Specimen Selection

Test specimens will be actual or simulated aircraft hardware, including all combustible materials that are applied to the actual structure in use. Heat flow paths and heat sinks will be as in the production configuration being certified.

12.4.2 Specimen Size

In general, specimen size will be 24 by 24 inches (610 by 610 mm). Larger specimens will be used if required to accommodate a critical design feature of the component. Smaller specimens 10 by 10 inches (254 by 254 mm) may be used if all design features are included and the specimen is representative of the intended use. For a smaller specimen, the backside of the specimen will be protected from exposure to the flame.

12.5 Conditioning

12.5.1 Specimen Conditioning

Specimens containing nonmetallic components will be preconditioned if required to simulate the aircraft environment.

12.6 Calibration

12.6.1 Place the thermocouple rake on the test stand such that the rake will be above the centerline of the burner or burner extension exit plane when the burner is in calibration position. Connect the thermocouples to a suitable recorder.

12.6.2 Light the burner, allow at least a 5-minute warmup, and move the burner into calibration (see section 12.3.4 for position).

12.6.3 Begin monitoring the temperatures indicated by the thermocouples after 5 minutes. Make adjustments as necessary to either the fuel flow or the airflow to the burner in order to achieve a minimum average thermocouple reading of 2,000°F (1,093°C).

12.6.4 Turn the burner off or move it out of calibration position and remove the thermocouple rake.

12.6.5 Replace the thermocouple rake with the heat flux density measuring device. Follow section 12.6.5.1 if using a water-cooled calorimeter for measuring heat flux density. Follow section 12.6.5.2 if using a Btu heat transfer device for this purpose.

12.6.5.1 If using the water-cooled calorimeter described in section 12.3.3.2, place the calorimeter at the same distance as the thermocouple rake centered over the burner exit.

12.6.5.1.1 Light the burner, allowing at least a 2-minute warmup, and move the burner into the calibration position.

12.6.5.1.2 Measure the heat flux density continuously or at intervals no greater than 10 seconds. If the heat flux density is not at least 9.3 Btu/ft-sec (10.6 W/cm) over a 1-minute period, readjust the burner to achieve the proper heat flux density. If burner adjustments are necessary, remove the heat flux density measuring device and repeat sections 12.6.1 through 12.6.5.1.2.

12.6.5.2 If using the Btu heat transfer device described in section 12.3.3.2, ensure the external surface of the copper tubing on the Btu heat transfer device is clean prior to measuring heat flux. Use fine steel wool to clean the copper tubing. Inspect the tubing bore and remove any corrosion and/or scale accumulation before each test. A .45-caliber pistol

cleaning brush, or equivalent, with an extension has been found suitable for this purpose.

12.6.5.2.1 The calibration setup is shown in figure 11-4. Provide a 5-foot (1.5-m) constant head of water above the heat transfer device and a 2-foot (0.61-m) drop to the end of the tailpipe for adjustment of the water flow rate. Use a 1-gallon (3.8-L) measuring container (a container and a weighing scale are also acceptable). Supply water at a temperature of 50° to 70°F (10° to 21°C). Adjust the water flow rate to 500 lb/hr (227 kg/hr) or 1 gal/min (3.8 L/min).

12.6.5.2.2 Start the water flowing through the Btu heat transfer device. Center the heat transfer tube in the flame at the same location that the specimen will be placed for testing. Allow at least a 2-minute warmup period to stabilize flame conditions before temperature measurements from the thermometers are recorded.

12.6.5.2.3 After the warmup period, record the inlet and outlet temperatures every 30 seconds for a 3-minute period. Determine the rate of Btu increase of the water as follows:

$$\begin{aligned}\text{Heat transfer} &= 146 \times (T_o - T_i) \text{ watts (for Celsius)} \\ &= 500 \times (T_o - T_i) \text{ Btu/hr (for Fahrenheit)}\end{aligned}$$

where: T_o = temperature (°C or °F) at outlet

T_i = temperature (°C or °F) at inlet

12.6.5.2.4 The heat transfer rate output, as determined by the equation shown in section 12.6.5.2.3, will be a minimum of 4,500 Btu/hr (1,314 W). If the heat output from the burner is not above the minimum, make adjustments to the burner and repeat sections 12.6.1 through 12.6.5.2.3.

12.7 Procedure

In general, tests will be conducted at ambient conditions. However, special airflow, pressure, vibration, etc., conditions may be required to simulate the actual aircraft operating environment. Load-carrying specimens will be tested with limit loads applied during the test.

12.7.1 Light the burner and allow at least a 2-minute warmup.

12.7.2 Place the test specimen in test position at the same distance from the burner as the thermocouple rake and calorimeter were placed during calibration.

12.7.3 Start the timer when the test specimen is properly positioned with respect to the burner. The critical or representative area of the test specimen will be aligned with the center of the burner.

12.7.4 Terminate the test by moving the burner or test specimen out of the test position after 15 minutes, as required for fireproof materials, or after 5 minutes, as required for fire-resistant materials.

12.7.5 Note the condition of both faces of the test specimen.

12.7.6 Without making adjustments to the burner flame, repeat the temperature measurements described in sections 12.6.1 through 12.6.3. If the average temperature has decreased by more than 150°F (66°C), readjust the burner and repeat the test with a new specimen.

12.8 Report

12.8.1 Fully identify the construction being tested and its use.

12.8.2 Describe the test apparatus and burner. Include the average flame temperature and heat flux density (or heat transfer rate) data for pretest calibration and the average temperature for posttest calibration.

- 12.8.3 Report the time the specimen is exposed to flame and whether the material or part is fireproof or fire resistant.
- 12.8.4 Describe the test specimen before and after testing.

12.9 Requirements

- 12.9.1 No flame penetration will occur for the duration of the test.
- 12.9.2 Burning on the backside of the specimen is not acceptable. Significant burning on the side of flame impingement will be investigated to determine if a potential increase in hazard exists. Minor flashing on either side of the specimen is acceptable.

Chapter 12 Supplement

This supplement contains advisory material pertinent to referenced paragraphs.

12.1.1 Advisory Circular AC20-135, "Powerplant Installation and Propulsion System Component Fire Protection Test Methods, Standards, and Criteria," February 6, 1990.

12.3.1 An SAE AS401B Propane Burner is also acceptable, provided the temperature profile and heat flux density conform to the requirements specified in this test method.

12.3.2 Thermocouples can be either grounded or ungrounded, depending on the type of data system used to monitor thermocouple output. One condition may generate more interference with instrumentation than the other.

12.6.1 If using one of the conversion oil burners described in section 1.1 for this test, the distance used to position the rake, heat flux measuring device, and test specimen will be 4 inches (101.6 mm) from the burner cone exit. If the burner used is an SAE AS401B Propane Burner, the distance used to position the thermocouple rake, etc., may be as close as 2 inches (50.8 mm) from the burner face exit in order to achieve the temperature and heat flux density specified in this test procedure.

12.6.2 If using an SAE AS401B Propane Burner, the flame is not turned off during calibration or test setup. Most test facilities using this burner have provisions for moving the burner in and out of test position. If using a conversion oil burner, most facilities turn the burner on and off to change specimens and calibration equipment. If the burner is turned off at any time, it will be warmed up for a 2-minute period before testing or taking calibration measurements.

12.6.5.1 Operating the calorimeter without water running through it will permanently damage the calorimeter.

Chapter 13

Test for Electrical Connectors Used in Firewalls

13.1 Scope

- 13.1.1 This test method is intended for use in determining the resistance of high-temperature electrical connectors used in fire zones to damage due to flame and vibration according to requirements of FARs 23.1192, 25.1191, 27.1191, 29.1192, 25.863, 25.865, 25.867, 25.1201, and 25.1203.
- 13.1.2 This test is used to evaluate the capability of wired, electrical, firewall connectors to prevent flame from passing to the protected side of the firewall. This test provides a means to evaluate the connectors' ability to sustain a minimum current of 1A for a limited period of time.
- 13.1.3 It is suggested that each connector type be tested in three sizes: 22-19, 14-7, and 12-3. Each connector size will be tested separately.

13.2 Definitions

13.2.1 Firewall

A firewall is a structure designed to prevent a hazardous quantity of air, fluid, or flame from exiting a designated fire zone in which a fire may erupt and causing additional hazard to the aircraft.

13.2.2 Firewall Connector

A firewall connector is an electrical connector designed for installation in the firewall.

13.3 Apparatus

13.3.1 Simulated Firewall

A piece of steel 10 by 10 by 0.063 inch (254 by 254 by 1.6 mm) thick to simulate a firewall will be provided for each of the three connector sizes. A hole will be drilled in the center of each piece appropriate to the respective connector size. If the simulated steel firewall does not adequately represent the actual application, a test of the proposed configuration may be required.

13.3.2 Burner/Torch

A burner/torch modified to produce and maintain a minimum flame temperature of 2,000°F (1,093°C) will be provided.

13.3.2.1 Burner Fuel

Propane gas fuel of 99 percent minimum purity will be used with a gas flow rate equivalent to 33,000 to 37,000 Btu/hr.

13.3.3 Power Supply (Electrical, AC)

A center-tapped transformer will be provided that is capable of producing between 200V and 260V (AC) at 400 Hz or 60 Hz and delivering a current of at least 2A.

13.3.4 Power Supply (Electrical, DC)

A power source will be provided that is capable of producing 28V (DC) and a current between 5A and 150A.

13.3.5 Current Indicator

A multirange ammeter will be provided that is capable of measuring DC currents between 5A and 150A with an accuracy of 1 percent of full scale.

13.3.6 Vibration Source

A means will be provided to vibrate the test fixture vertically at 33 Hz with a total excursion of 0.14 inch (3.6 mm).

13.3.7 Gas Flowmeter

A gas flowmeter will be provided to measure the fuel flow to the burner/torch.

13.3.8 Temperature Measuring and Recording Equipment

A temperature sensing system will be provided that includes a thermocouple and a stripchart recorder to monitor the flame temperature.

13.3.8.1 Thermocouple

An ANSI 22-gauge Chromel-Alumel (Type K) thermocouple sheathed to a 1/16-inch (1.6-mm) stainless steel or inconel tube shall be provided.

13.3.9 High-Temperature Tape

High-temperature tape, 19 to 25 mm wide, will be provided in sufficient length to wrap over the connector and wire bundles (see section 13.4.2.1).

13.3.10 Test Fixture

A test fixture and setup such as is shown in figure 13-1, including a cable clamp to stabilize the wire bundle connector interface during the test, will be provided.

13.3.11 Timer

A stopwatch or other device, calibrated and graduated to the nearest 1 second, will be used to measure the time of application of the burner flame.

13.4 Test Specimens

13.4.1 Specimen Number

Prepare at least three specimens for each connector shell size to be tested.

13.4.2 Specimen Preparation

Clean all oil, grease, dirt, and other foreign material from the specimens.

13.4.2.1 Wrap the plug and receptacle wire bundle with high-temperature tape over the area to be located under the cable clamp that is used to stabilize the wire bundle connector interface during flame/vibration application. This area is a distance of 7.9 ± 0.2 inches (200 ± 5 mm) from the connector backshell. See figures 13-2 and 13-3 for details.

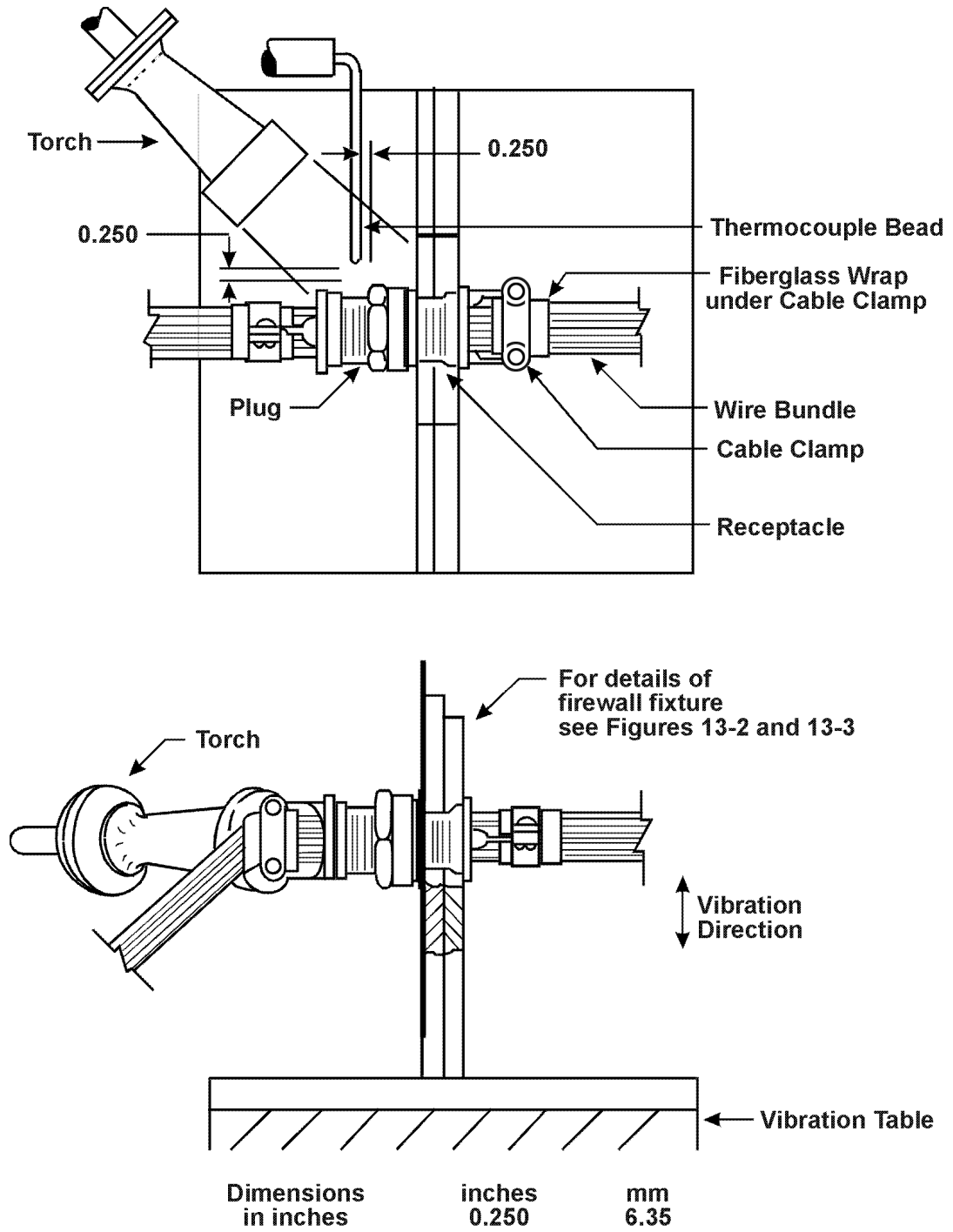

Figure 13-1. Firewall Connector Test Setup

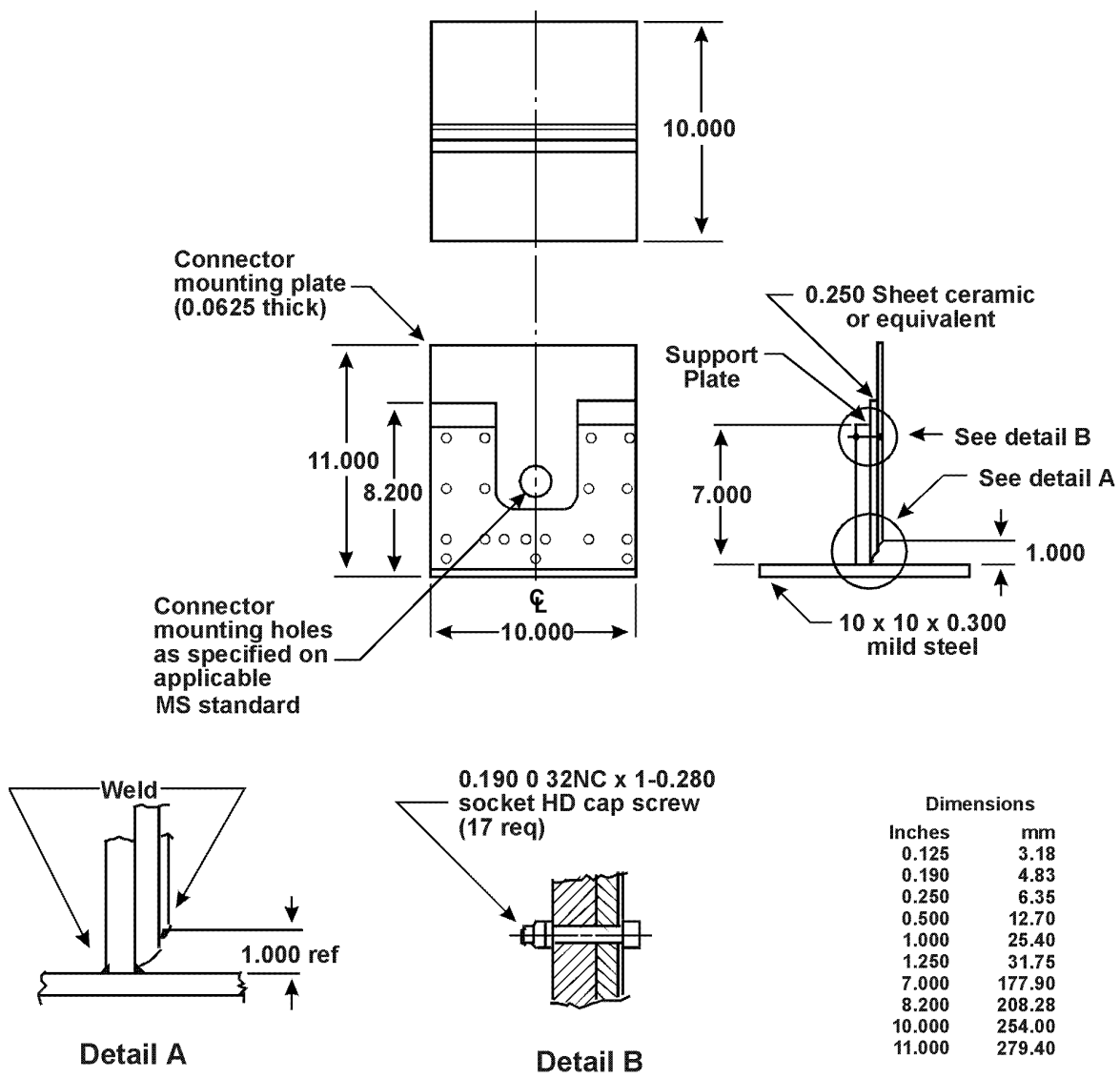
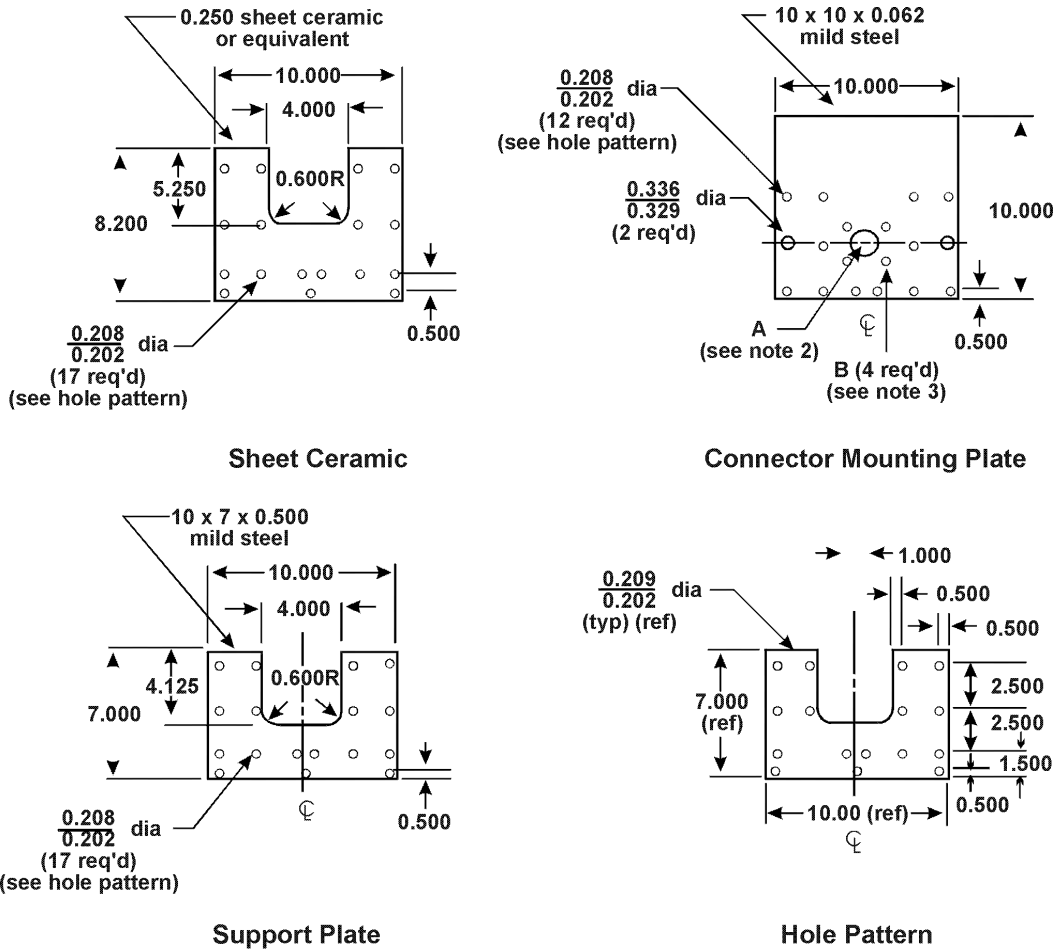

Figure 13-2. Firewall Connector Fixture Assembly



- Notes:
1. Dimensions are in inches. Unless otherwise specified, dimensions symmetrical about centerline.
 2. A hole shall provide suitable clearance for the applicable connector.
 3. B connector mounting holes shall be as specified on the applicable MS standard.

Inches	mm
0.125	3.18
0.190	4.83
0.250	6.35
0.500	12.70
1.000	25.40
1.250	31.75
7.000	177.80
8.200	208.28
10.000	254.00
11.000	279.40

Figure 13-3. Firewall Connector Fixture Details

13.4.2.2 Connect the individual wires through the connector such that the circuit will be closed. Ensure that the connector shell is grounded during the test.

13.5 Procedure

13.5.1 Test Setup

Mount the simulated firewall on the vibration equipment table. Mount the connector that has been wired, mated, and prepared as described in sections 13.4.2.1 and 13.4.2.2 in the center of the simulated firewall test fixture.

13.5.1.1 Support the wire bundle, using clamps to a stationary structure at a distance of 7.9 ± 0.2 inches (200 ± 5 mm) from the connector backshell on each side of the connector to protect from vibration.

- 13.5.1.2 Ensure that the connector shell is well grounded prior to starting the test.
- 13.5.1.3 Use a circuit for the test designed so that by closing one switch or relay (designated as Switch 2), the connector contacts are connected in series and the direct current potential is applied and, by closing another switch or relay (designated Switch 1), the alternating current potential is applied between even and odd numbered contacts, as shown in figure 13-4.

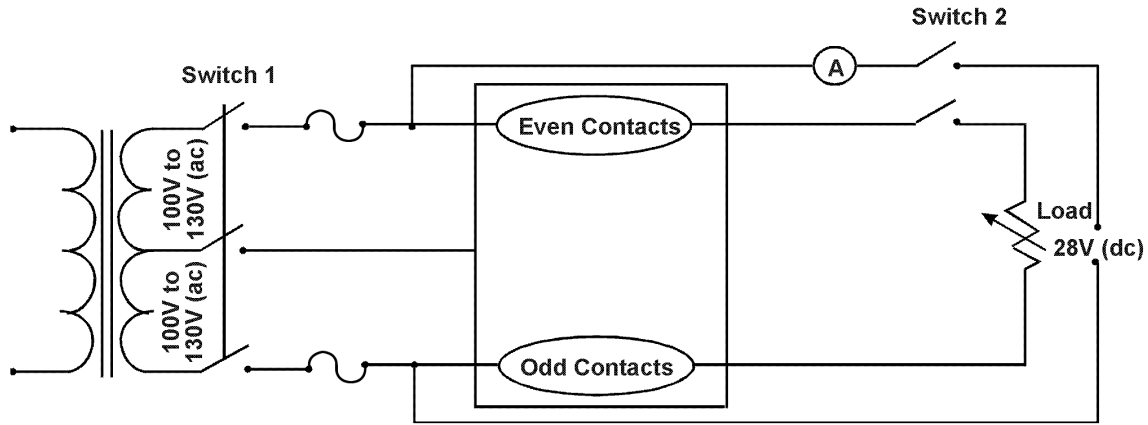

Figure 13-4. Connector Electrical Integrity Connection Diagram

13.5.2 Burner Adjustment

Ignite the burner/torch and adjust the flow of gas and air to obtain a nonoxidizing and nonreducing flame with a flame temperature of $2,000^{\circ} \pm 50^{\circ}\text{F}$ ($1,093^{\circ} \pm 28^{\circ}\text{C}$).

13.5.3 Test Procedure

- 13.5.3.1 Light the burner and stabilize the flame at a minimum temperature of $2,000^{\circ}\text{F}$ ($1,093^{\circ}\text{C}$) for 5 minutes prior to starting the test.
- 13.5.3.2 Turn on the vibration source and connect the circuit, as described in section 13.5.1.3.
- 13.5.3.3 Simultaneously start the timer and direct the flame at the plug side of the connector test specimen, as shown in figure 13-2, at a distance such that the thermocouple monitoring the temperature is within 0.26 inch (6.5 mm) of the connector. Monitor the temperature of the flame continuously.
 - 13.5.3.3.1 For the first 5 minutes of the test, connect the contacts in series and load with their rated DC current for the appropriate size contact as determined by table 13-1. Start the current flow by closing Switch 2. Monitor the current continuously using the ammeter to determine whether or not the connector circuit retains its conductance.

Table 13-1. Firewall Connector Test Current

Contact Size	Test Current (DC)
22	5
20	7.5
16	13
12	23
8	46
4	80
0	150

- 13.5.3.4 At the end of 5 minutes, the difference in potential of the even and odd numbered contacts will be 200V to 260V (AC) and the difference in potential between the shell and any contact will be 100V to 130V (AC). Remove the DC source and break the series connection by closing Switch 1. Immediately after Switch 1 is closed, apply the AC potential by opening Switch 2. Do not allow the circuit to draw a current greater than 2A. At the end of 1 minute, shut off the current. Observe and record any indication of an increase in current that would show a contact-contact or a contact-shell short circuit.
- 13.5.3.5 Continue the flame exposure of the connector until a total time of 20 minutes has elapsed and monitor whether any flame appears on the protected side of the firewall.

13.6 Report

13.6.1 Material Identification

Identify the material being tested.

13.6.2 Flame Penetration

Report whether any flame was detected on the protected side of the firewall during the test.

13.6.3 Conductivity

Report the minimum current that occurred during the application of electrical power.

13.6.4 Circuit Integrity

Report any evidence of a contact-contact or a contact-shell short circuit.

13.7 Requirements

13.7.1 Flame Penetration

There will be no flame detected on the protected side of the firewall barrier at any time during the 20-minute test.

13.7.2 Conductivity

The current through the connector during the application of electrical power will not be less than 1A.

13.7.3 Circuit Integrity

There shall be no evidence of any contact-contact or contact-shell short circuit.

13.7.4 Backside Ignition

There shall be no ignition on the backside of the wire bundle.

Chapter 13 Supplement

This supplement contains advisory material pertinent to referenced paragraphs.

13.3.2 An SAE AS401 Propane Burner or equivalent has been found acceptable.

13.3.5 Choose the appropriate range of the ammeter to measure the test current. The appropriate range will show the current to be in the middle one-third of the scale.

13.3.9 Untreated fiberglass tape has been found satisfactory.

Chapter 14

Test for Electrical Wire Used in Designated Fire Zones

14.1 Scope

- 14.1.1 This test method is intended for use in determining the resistance of high-temperature electrical wire used in designated fire zones to damage due to flame and vibration according to the requirements of FARs 25.863, 25.865, 25.867, 25.1201, 25.1203, and 25.1359.
- 14.1.2 This test method generally follows MIL-W-25038E. The method is used predominantly in the United States and by most wire and cable manufacturers. ISO/DIS 2685.2 is a similar test procedure and is used by Aerospatiale in France and by the Civil Aviation Authority in Great Britain.

14.2 Definitions

14.2.1 Ignition Time

Ignition time is the length of time the burner flame is applied to the specimen. In this test, the ignition time is 5 minutes.

14.2.2 Wire

A single insulated electrical conductor.

14.2.3 Designated Fire Zone

A region of the aircraft, such as engine and auxiliary power unit compartments, designated to require fire detection and extinguishing equipment and, as appropriate, the use of materials that are fire resistant or fireproof.

14.2.4 Fire Resistant

Per FAR Part 1, (found in Subchapter A—Definitions, Part I—Definitions and Abbreviations) “with respect to fluid carrying lines, fluid system parts, wiring, air ducts, fittings, and powerplant controls means the capacity to perform the intended functions under the heat and other conditions likely to occur when there is a fire at the place concerned.”

14.2.4.1 Electrical wire is demonstrated to be fire resistant by meeting the requirements of this 5-minute test.

14.2.5 Firewall

A structure designed to prevent a hazardous quantity of air, fluid, or flame from exiting a designated fire zone in which a fire has erupted and causing additional hazard to the aircraft.

14.2.6 Fire Zone Wire

A wire installed in a designated fire zone.

14.3 Apparatus

14.3.1 Test Fixture

A test fixture, such as shown in figure 14-1, will be provided. The fixture will include a provision for mounting above the test burner.

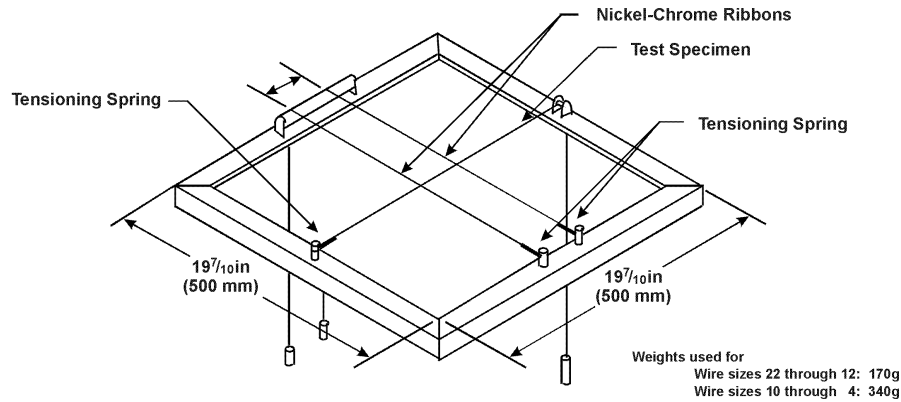

Figure 14-1. Firezone Electrical Wire Test Setup

14.3.2 Test Burner

A test burner, such as shown in figure 14-2, will be provided. The burner will include provisions for introducing air premixed with the gas fuel and for introducing secondary air into the burner flamelets.

14.3.2.1 Burner Fuel

Propane gas of 99 percent purity will be used for the burner fuel.

14.3.2.2 Plumbing for Gas Supply

The necessary gas connections, tubing, pressure regulators, and gauges will be provided.

14.3.3 Vibration Source

A means will be provided to vibrate the test fixture vertically at 33 Hz with a total excursion of 0.14 inch (3.5 mm).

14.3.4 Thermocouple

A 22-gauge ANSI (Type K) Chromel-Alumel thermocouple or equivalent, as shown in figure 14-3, will be provided to measure the temperature of the burner flame. In addition, a device to continually monitor the thermocouple output within an accuracy of 5 percent will be provided.

14.3.5 Ammeter

An ammeter will be provided that measures a current of at least 2A within an accuracy of 5 percent.

14.3.6 Ohmmeter

An ohmmeter will be provided to measure resistance within an accuracy of 5 percent of full scale.

14.3.7 Power Source

A power supply will be provided that will deliver 2A at 115V AC, 400 Hz or 60 Hz.

14.3.8 Nickel-Chrome Ribbons

Two nickel-chrome ribbons that are 0.010 by 0.059 by 23.6 inches (0.25 by 1.5 by 600 mm) will be provided (see figure 14-1).

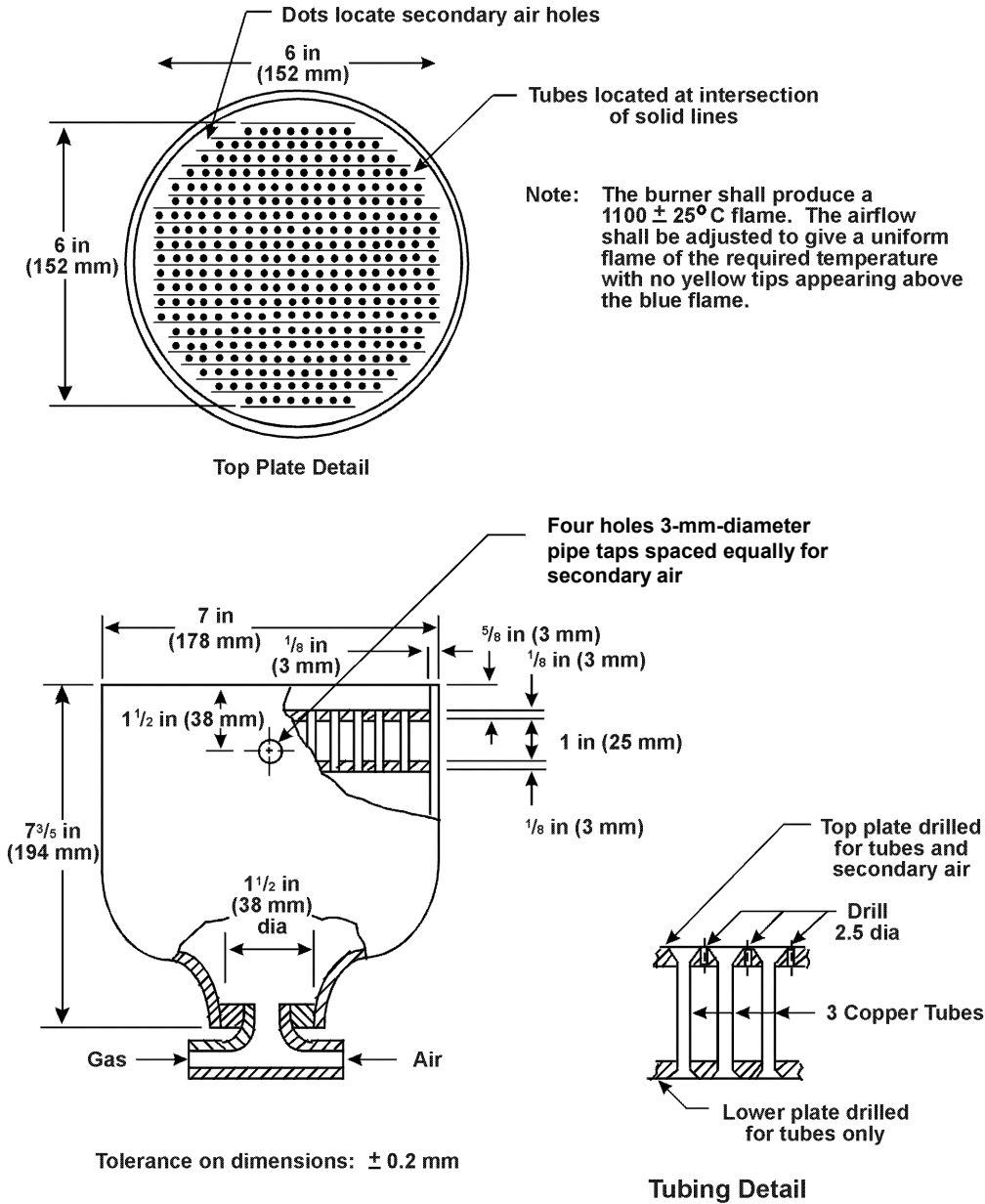

Figure 14-2. Burner Details

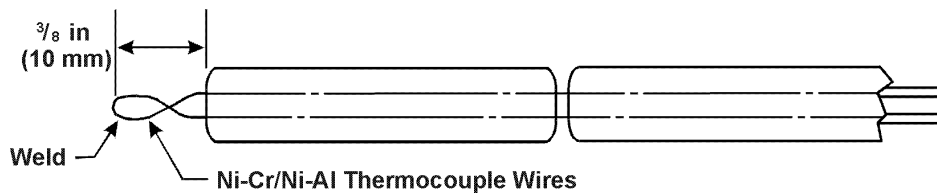

Figure 14-3. Thermocouple Details

14.3.9 Weights

Weights are required to tension the wire over the test fixture. Suggested weights are 12 ounces (340 g) for wire sizes 4 through 10 and 6 ounces (170 g) for wire sizes 12 through 22.

14.3.10 Reagents and Materials

The following materials found in the fire zone of intended use may be necessary to condition the specimens prior to the test:

14.3.10.1 Aviation fuel such as JP-4 or JP-5 or per MIL-G-5572

14.3.10.2 Lubricating oil per MIL-L-6082, Grade 1100

14.3.10.3 Hydraulic fuel per MIL-H-5606

14.3.11 Timer

A stopwatch or other device, calibrated and graduated to 1 second, will be used to measure the time of application of the burner flame.

14.4 Test Specimens

14.4.1 Specimen Length

Specimens will be 24 inches (610 mm) in length.

14.4.2 Specimen Number

Twelve test specimens will be prepared unless otherwise specified. Three specimens will be tested for each condition: no conditioning, conditioning in aviation fuel, conditioning in hydraulic fuel, and conditioning in lubricating oil (see section 14.5.1).

14.5 Conditioning/Preparation of Test Specimens

14.5.1 Test Conditions

Each wire type will be tested without being exposed to any contaminating fluid and after being exposed to each of the fluids described in section 14.3.10. Three test specimens will be used for each of the test conditions.

14.5.1.1 Immerse three test specimens in each test fluid for the times and temperatures shown in table 14-1. Wipe the test specimens with a clean cloth after removing them from the fluids.

Table 14-1. Specimen Immersion Information

Specimen No.	Test Fluid	Immersion	
		Time (hr)	Temp (°C)
1	Mil-G-5572 (grade 100/130)	24	23
	JP-5	24	23
	JP-4	24	23
2	50% JP-4 and 50% MIL-L-6082	24	23
3	MIOL-L-6082	24	121
4	Skydrol 50084/L04 (aero)	24	23
5	Ethylene Glycol (aero)	24	121

14.5.1.2 Locate the point on the wire specimen that will be located directly above the center of the burner when the wire specimen is placed on the test stand. Mark a 7-inch (178-mm) -long section with this point in its center by placing a wire band around the specimen

3 1/2 inches (89 mm) on each side of this point. In addition, place an outer wire band around the test specimen 4 inches (102 mm) outside each of these two bands.

14.5.2 Store each set of test specimens in a separate airtight container until the time of the test.

14.6 Calibration

14.6.1 Position the thermocouple as shown in figure 14-3, 1 inch (25 mm) above the center of the burner top plate, as shown in figure 14-4.

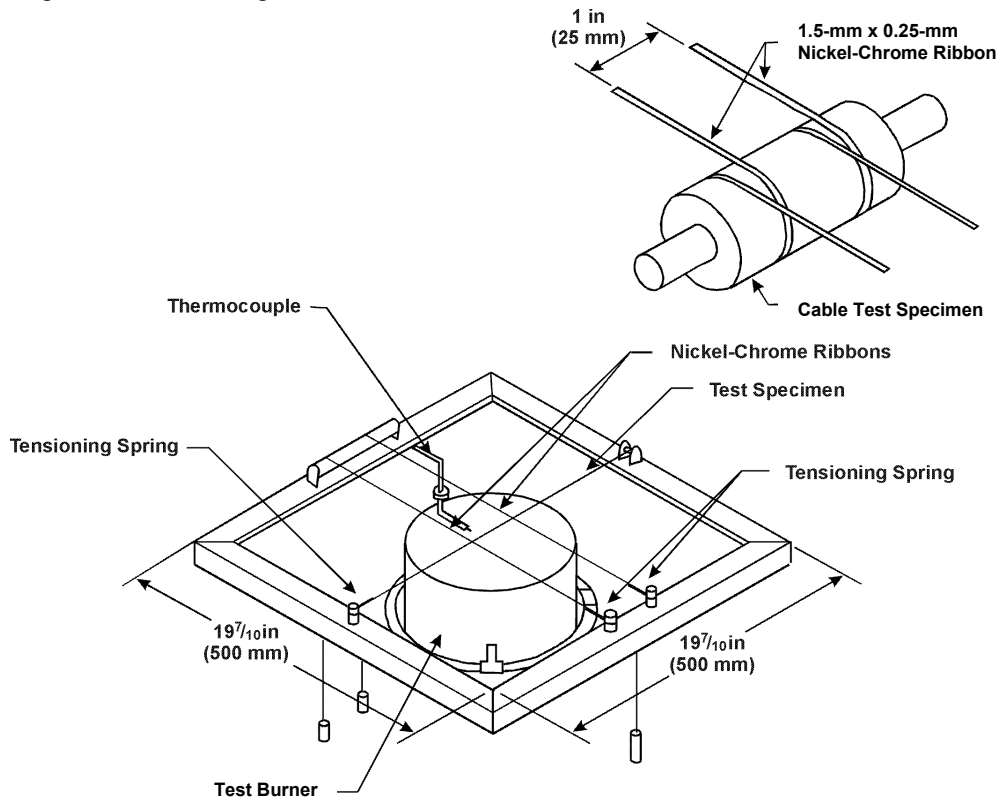

Figure 14-4. Fire Zone Electrical Wire Test Setup—Top View

14.6.2 Ignite the burner and adjust the fuel, air, and secondary air to the burner to obtain a nonoxidizing, nonreducing flame with no yellow tips at a temperature of $2,000^{\circ} \pm 50^{\circ}\text{F}$ ($1,093^{\circ} \pm 28^{\circ}\text{C}$). Stabilize the flame for 5 minutes.

14.6.3 Turn off the burner after the flame is properly adjusted.

14.7 Procedure

14.7.1 Test Setup

Position the test specimen 1 inch (25 mm) above the burner top plate. Place the center 7-inch (178-mm) section of the specimen above the center of the burner (see figure 14-4).

14.7.1.1 Position the two nickel-chrome ribbons at a distance of 1 inch (25 mm) apart, as measured at the center 7-inch (178-mm) section of the ribbons and perpendicular to the test specimen. Clamp one end of each of the nickel-chrome ribbons to the test fixture. Wrap the nickel-chrome ribbons around the wire and tension with weights. Lock the wires at the pulley or clamp them to the test fixture. See figure 14-4 for details.

14.7.1.2 Connect the conductor and the nickel-chrome ribbons as shown in figure 14-5.

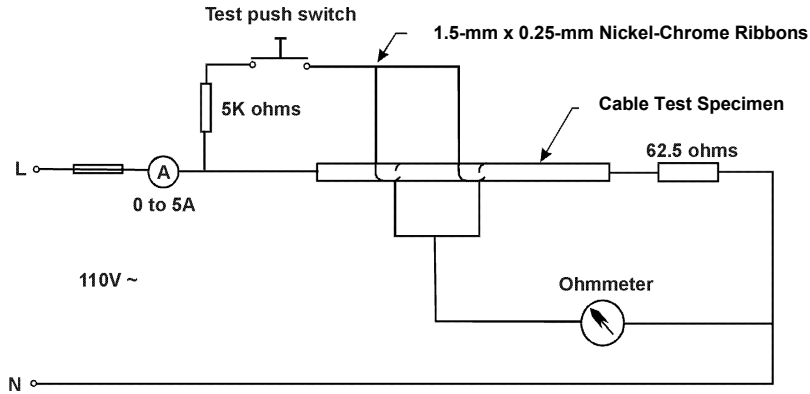

Figure 14-5. Electrical Connections

14.7.1.3 Insert a shorting bar between the conductor and the nickel-chrome ribbons. Adjust the ohmmeter to zero in this position.

14.7.1.4 Start the vibration using a frequency of 33 Hz and a vertical amplitude of 0.014 inch (3.5 mm).

14.7.2 Test Procedure

Start the vibration using a frequency of 33 Hz and a vertical amplitude of 0.014 inch (3.5 mm).

14.7.2.1 Simultaneously start the timer and apply the ignited burner to the specimen.

14.7.2.2 Monitor the flame temperature for the duration of the test. Adjust the secondary air continually as necessary to keep the flame and the temperature within the limits specified in section 14.6.2.

14.7.2.3 Monitor and record the insulation resistance shown by the ohmmeter for the duration of the test, starting at 7.5 seconds after the test begins. In addition, record the lowest resistance shown by the ohmmeter during the test.

14.7.2.4 Monitor and record the current in the conductor during the test with the ammeter.

14.7.2.5 Turn off the burner and the vibration, in that order, at the end of the 5-minute test period.

14.8 Report

14.8.1 Material Identification

Fully describe the wire type being tested. Include manufacturer, manufacturer's product designation, manufacturer's part number, specification callout (if applicable), insulation type, conductor size, and material.

14.8.2 Insulation Integrity

Report whether the insulation flakes or falls off the conductor.

14.8.3 Insulation Resistance

Report the insulation resistance at 7.5 seconds into the test and the lowest resistance occurring during the test and the time of its occurrence.

14.8.4 Flame Travel

Report whether flame travel on the wire extended beyond the outer marking bands.

14.8.5 Conductor Amperage

Report the amperage carried through the conductor throughout the duration of the test.

14.9 Requirements

The following acceptance criteria must be met by each specimen tested.

14.9.1 Insulation Integrity

The insulation will not flake excessively or fall off the conductor.

14.9.2 Insulation Resistance

The minimum insulation resistance of the wire under test will be at least 10,000 ohms for the duration of the test.

14.9.3 Flame Travel

The flame travel on the insulation will not exceed beyond the outer bands.

14.9.4 Conductor Amperage

The conductor will be able to carry a current of at least 2A throughout the duration of the test.

Chapter 14 Supplement

This supplement contains advisory material pertinent to referenced paragraphs.

14.3.2 See SAE AS-8028 for burner details.

14.3.10 The reagents needed for conditioning vary, depending on the airframe manufacturer.

14.4.1 ISO/DIS 2685.2 calls out test specimens that are 30 inches (750 mm) long. MIL-W-25083 calls out test specimens that are 24 inches (600 mm) long. The difference in length does not affect test results.

14.5.1 All current industry specifications require only one specimen for each fluid. However, testing three specimens for each fluid will provide a greater degree of confidence in results.

14.5.1.2 The wire band consists of one turn of AWG 30 or smaller wire.

14.7.2.5 Monitoring the conductor has been added in addition to the requirements found in MIL-W-25038. This is done in both the firewall connector test procedure MIL-STD-1344 Test Method and the ISO/DIS 2685.2 test procedure for wire. The integrity of the conductor would be as important as the integrity of the insulation if the wire were faced with an in-flight fire situation.

Chapter 15

Two Gallon per Hour Oil Burner Certification Testing for Repaired Cargo Compartment Liners

15.1 Scope

- 15.1.1 This test method gives certification test procedures for repair of damaged cargo liners which would include, but not be limited to, ceiling and sidewall liners, pressurized cylinder cover liners, fabric liners, and compartment separation liners. Repairs should not be made to areas of the cargo liner that are designed for blowout in case of decompression.
- 15.1.2 Repairs generally consist of patches of fiberglass reinforced materials bonded to the cargo liners to cover rips, tears, and punctures that result from wear, abuse, and accidents. The patches are usually coated with an intumescent-type material to prevent separation during heat exposure.
- 15.1.3 Because of the large array of damage types that can occur to cargo liners, the following test procedures are aimed at ensuring that all types of repairs can safely contain a cargo compartment fire.
- 15.1.4 Soft or neoprene-coated fabric liners, typically used as partition separators, must also be included in this category and should follow the identical testing procedures as the conventional liners when repairs are made.

15.2 Test Specimens

The sample cargo liner used in the test specimens must be identical to the in-service liner in both material type and thickness, since certain thicknesses of liner may react quite differently than others. Thicker liners release significantly more amounts of heat than do thinner liners. Thinner (conventional type) liners contain less reinforcement, thereby providing less structural support to which the repair unit can adhere. If a patch is intended for use on a variety of liner thicknesses, tests should be run for each thickness. As an alternative, tests may be run on the minimum and maximum thicknesses of liners that the repair patch will be used on in service to alleviate the testing of all thicknesses within this range. Similarly, if there are several variants of a particular liner resin structure (i.e., fiberglass reinforcement with several slightly different phenolic resins), it is only necessary to test the generic construction (fiberglass/phenolic) and not every single resin type.

15.2.1 Liner Repair Burnthrough Resistance Specimen

15.2.1.1 Specimen Configuration

A flat sheet of material, identical to that used in the construction of the repair unit (patch), must be tested for resistance to burnthrough in the ceiling position of the cargo liner test apparatus.

15.2.1.2 Specimen Size

The burnthrough resistance sample shall measure 16 by 24 inches and contain the necessary mounting holes, as shown in figure 15-1.

15.2.1.3 Specimen Number

A minimum of three samples for each type of repair unit material shall be prepared.

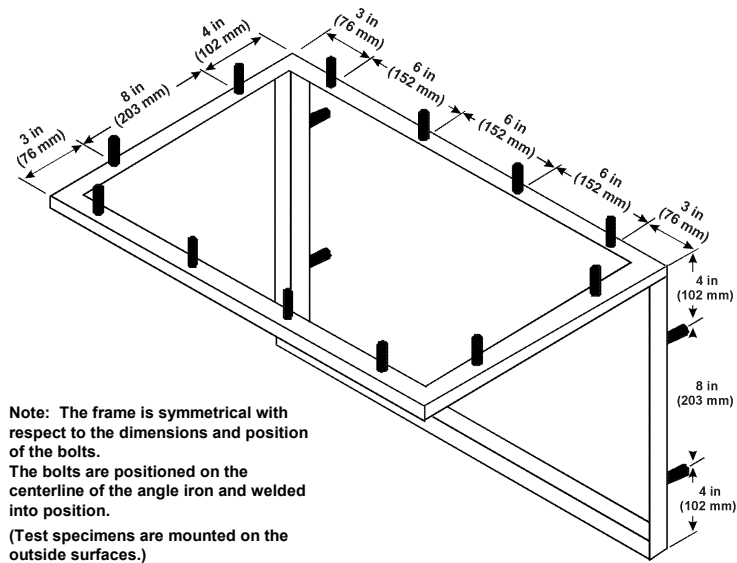

Figure 15-1. Cargo Liner Test Specimen Frame

15.2.2 Liner Repair Adhesion Specimen

15.2.2.1 Specimen Configuration

The repair patch must be placed over the standard damage area in the sample liner. The damage area must measure 5 by 5 inches with a width of 1 inch, in the form of an L-shape, and positioned according to figure 15-2. The placement of the repair patch in this location has been shown to be the most severe.

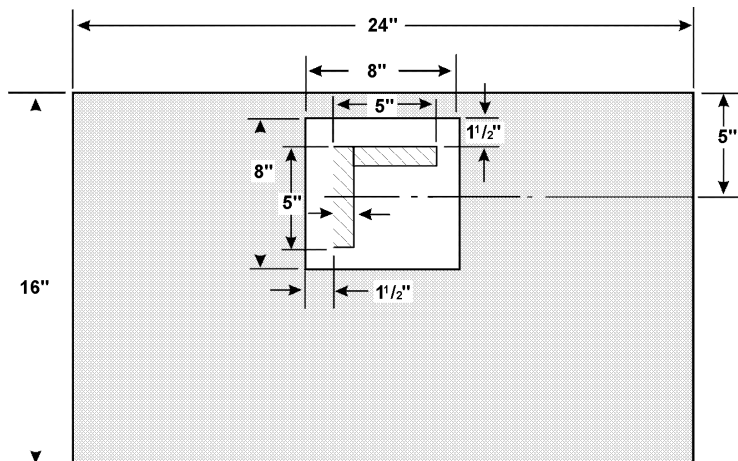

Figure 15-2. Eight-by-Eight-Inch Patch Over Standard Damage

15.2.2.2 Specimen Size

The repair patch must measure 8 by 8 inches and be positioned over top of the damage area, according to figure 15-2. The liner sample must measure the standard 16 by 24 inches including the necessary mounting holes (see figure 15-1).

15.2.2.3 Specimen Number

A minimum of three samples must be prepared for each type of repair unit material.

15.2.3 Liner Repair Shingling Specimen

15.2.3.1 Specimen Configuration

Two 4- by 4-inch patches must be overlapped by 1 inch and placed over the standard damage area in the sample liner. The damage area must measure 1 by 5 inches and be positioned as shown in figure 15.3.

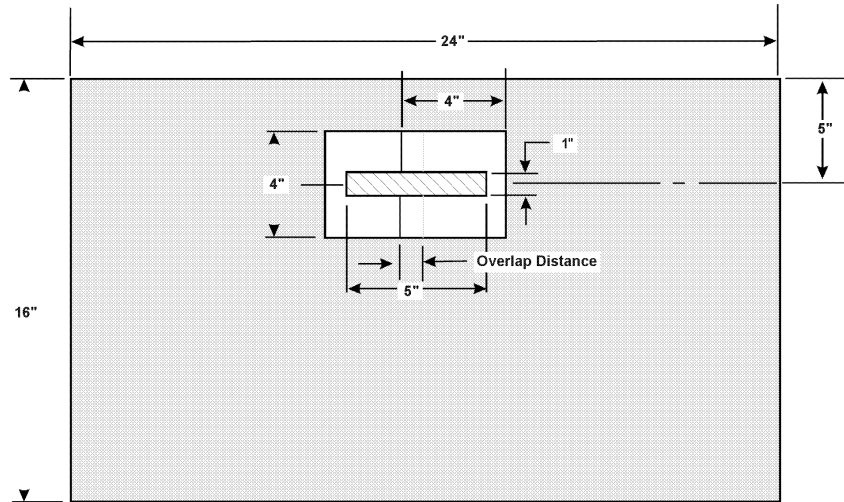

Figure 15-3. Overlapped Patches for Shingling Test

15.2.3.2 Specimen Size

Patches must measure 4 by 4 inches, and the sample liner must measure the standard 16 by 24 inches including mounting holes (see figure 15-1).

15.2.3.3 Specimen Number

A minimum of three samples must be prepared for each type of repair patch.

15.3 Specimen Conditioning

15.3.1 The specimens shall be conditioned at $70^{\circ} \pm 5^{\circ}\text{F}$ ($21^{\circ} \pm 2^{\circ}\text{C}$) and $55\% \pm 5\%$ relative humidity for a minimum of 24 hours prior to testing.

15.4 Procedure

Reference FAA technical documents DOT/FAA/CT-TN88/33, DOT/FAA/CT-TN89/17, and DOT/FAA/AR-TN95/83 for a description of related test results and the development of this test procedure.

15.4.1 Burnthrough Resistance Test

The material that comprises the primary fire barrier of the repair patch must be tested in a flat sheet, 16 by 24 inches, in the ceiling position of the cargo liner test apparatus. The sidewall area of the apparatus should be blocked off with either Kaowool ceramic fiber board or Marinite block. Follow procedures in chapter 8, section 8.8 to conduct the burnthrough test.

15.4.2 Adhesion Test

In addition to the burnthrough resistance test, the repair patch must also display the ability to remain adhered to the liner specimen under the same conditions. The patched liner will be tested in the ceiling position of the test apparatus with the sidewall area blocked off with Kaowool board or

Marinite. Follow the procedures outlined in chapter 8, section 8.8 paying close attention to the positioning of the repair patch over the standard damage area.

15.4.3 Shingling Test

The repair patch must also display its ability to shingle, since most repairs are long tears, and a single patch is not sufficient to cover the entire damage area. The overlapped patches, when placed on the liner specimen material, must be tested in the ceiling position of the cargo liner apparatus with the sidewall area blocked off with either Kaowool board or Marinite block. Follow the procedures in chapter 8, section 8.8 to conduct the test.

15.5 Report

A record of burner test apparatus calibration should be provided for each of the above repair patch tests.

15.5.1 Burnthrough Resistance Test of Repair Patch

- 15.5.1.1 Report a complete description of the material(s) being tested including manufacturer, type of liner, thickness of liner, etc.
- 15.5.1.2 Record any observations regarding the behavior of the test specimen during flame exposure such as delamination, resin ignition, smoke, etc., and the time of occurrence of each event.
- 15.5.1.3 Report the time of occurrence of flame penetration, if applicable, for each of the specimens tested.
- 15.5.1.4 If flame penetration does not occur, report the maximum backside temperature and the time of occurrence.

15.5.2 Adhesion Test of Repair Patch

- 15.5.2.1 Report a complete description of the material(s) being tested including manufacturer; type of repair patch; type of intumescent coating, if used; type and thickness of liner specimen; type of attachment (rivets); etc.
- 15.5.2.2 Record any observations regarding the behavior of the test specimen during flame exposure such as delamination, separation of repair patch from sample liner, lifting or curling of repair patch edges, resin ignition, smoke, etc., and the time of occurrence of each event.
- 15.5.2.3 Report the time of occurrence of either flame penetration or repair patch separation, if applicable, for each of the specimens tested.

15.5.3 Shingling Test of Repair Patch

- 15.5.3.1 Report a complete description of the material(s) being tested including manufacturer; type of repair patch; type of intumescent coating, if used; type and thickness of liner; type of attachment (rivets); etc.
- 15.5.3.2 Record any observations regarding the behavior of the test specimen during flame exposure such as delamination; separation of the two patches, allowing passage of flames; lifting or curling of repair patch edges; resin ignition; smoke; etc., and the time of occurrence of each event.
- 15.5.3.3 Report the time of occurrence of either flame passage or patch separation, if applicable, for each of the specimens tested.

15.6 Requirements

15.6.1 Liner Repair Burnthrough Resistance

- 15.6.1.1 None of the three specimens tested shall burn through at any time during the 5-minute test.
- 15.6.1.2 The backface temperature must not exceed 400°F at any time for any of the test specimens when measured at 4 inches above the liner sample, over the center point of the burner cone.

15.6.2 Liner Repair Adhesion

- 15.6.2.1 The repair unit must remain totally adhered to the liner specimen during the entire 5-minute test. Minor curling or lifting of the repair patch that occurs near the edges is acceptable, provided no flames penetrate the standard damage area.

15.6.3 Liner Repair Shingling

- 15.6.3.1 Repair units (4- by 4-inch patches) must remain totally adhered to the liner specimen during the entire 5-minute test. Minor curling or lifting of the repair patch that occurs near the edges is acceptable, provided the shingled area remains attached along the entire seam and no flames penetrate the standard damage area.

Chapter 16. Reserved

Chapter 17. Reserved

Chapter 18

Recommended Procedure for the 4-Ply Horizontal Flammability Test For Aircraft Blankets

18.1 Scope

This test method is intended for use in determining the resistance of blankets to flame when tested in the horizontal position and exposed to the Bunsen burner for 12 seconds.

18.2 Definitions

18.2.1 Ignition Time

Ignition time is the length of time the burner flame is applied to the specimen. It is 12 seconds for this test.

18.2.2 Flame Time

Flame time is the time in seconds that the specimen continues to flame after the burner flame is removed from beneath the specimen. Surface burning that results in a glow but not in a flame is not included.

18.2.3 Drip Flame Time

Drip flame time is the time in seconds that any flaming material continues to flame after falling from the specimen to the floor of the chamber. If no material falls from the specimen, the drip flame time is reported to be zero (0) seconds, and the notation "No Drip" is reported. If there is more than one drip, the drip flame time reported is that of the longest flaming drip. If succeeding flaming drips reignite earlier drips that flamed, the drip flame time reported is the total of all flaming drips.

18.3 Test Apparatus

18.3.1 Test Cabinet

The test will be conducted in a draft-free cabinet fabricated in accordance with figures 18-1, 18-2, and 18-3, or other equivalent enclosures acceptable to the FAA. A hole may be drilled into a wall to accommodate the test fixture. It is suggested that the cabinet be located inside an exhaust hood to facilitate clearing the cabinet of smoke after each test. Stainless steel or other corrosion resistant metal 0.04 inch (1 mm) thick will be used for the bottom surface of the chamber.

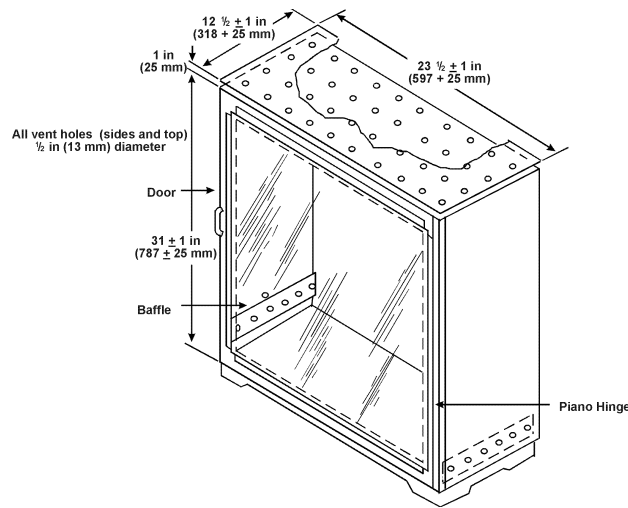

Figure 18-1. Sketch of Bunsen Burner Test Cabinet

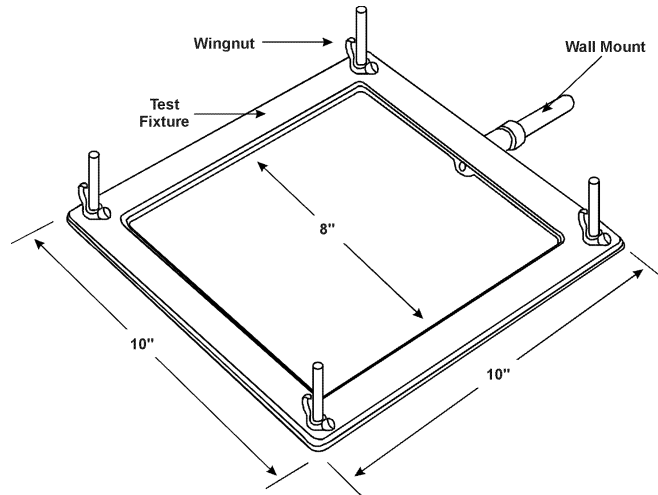

Figure 18-4. Horizontal Test Fixture

18.3.3 Burner

The burner shall be a Bunsen or Tirrill type, have a 3/8-inch (10-mm) inside diameter barrel and be equipped with a needle valve located at the bottom of the burner barrel to adjust the gas flow rate and, thereby, adjust the flame height. There should be a means provided to move the burner into and out of test position when the cabinet door is closed.

18.3.3.1 Burner Fuel

Methane gas (99 percent minimum purity) or other burner fuel acceptable to the FAA will be used. Methane is the preferred fuel. It can be used without adding air through the aspirating holes at the bottom of the burner flame barrel, i.e., a pure diffusion flame may be used.

18.3.3.2 Plumbing for Gas Supply

The necessary gas connections and the applicable plumbing are essentially as shown in figure 18-5. A control valve system with a delivery rate designed to furnish gas to the burner under pressure of $2 \frac{1}{2} \pm \frac{1}{4}$ psi (17 ± 2 kPa) at the burner inlet should be installed between the gas supply and the burner.

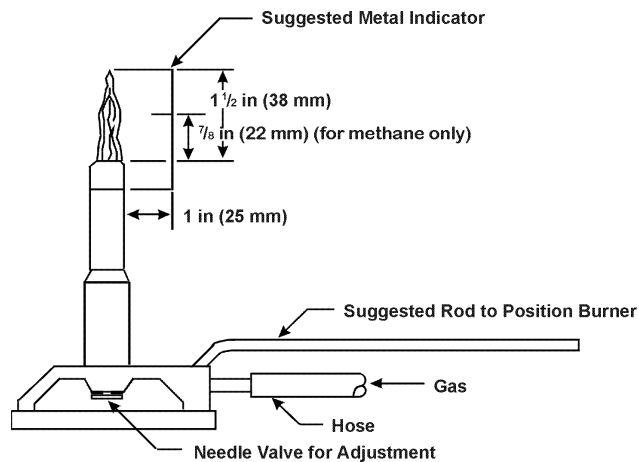

Figure 18-5. Burner Plumbing and Burner Flame Height Indicator

18.3.3.3 Flame Height Indicator

A removable height indicator aids in setting the height of the flame. A suitable indicator has a prong extending 1.5 inches (38 mm) above the top of the burner barrel and spaced 1 inch (25 mm) from the burner barrel, as shown in figure 18-5. If using methane as the burner fuel, it is desirable to have two prongs for measuring the flame height, one prong to indicate the height of the inner cone of the flame, and one prong to indicate the height of the tip of the flame. For methane, it has been determined that when the height of the inner flame is 1.5 inches (38 mm) long the proper flame profile is achieved.

18.3.4 Timer

A stopwatch or other device calibrated to the nearest 0.1 second shall be used to measure the time of application of the burner flame, the flame time, and the drip flame time.

18.4 Test Specimens

18.4.1 Specimen Selection

Specimens tested should be cut from new aircraft blankets. If each side of a blanket is composed of a different material, then each side must be tested.

18.4.2 Specimen Number

At least three specimens will be prepared and tested.

18.4.3 Specimen Size

An 8- by 8-inch specimen is the exposed sample size, however, an 11- by 11-inch specimen should be cut in order to pull the specimen taut once secured in the test fixture. The excess material can be trimmed off.

18.4.4 Specimen Thickness

The specimen will be of four-ply configuration. This may be accomplished by folding the blanket in half and then folding it again or by stacking four individual blanket specimens cut to size. This also includes blankets with decorative appliques.

18.5 Conditioning

18.5.1 Condition specimens at $70^{\circ} \pm 5^{\circ}\text{F}$ ($21^{\circ} \pm 3^{\circ}\text{C}$) and $50\% \pm 5\%$ relative humidity for 24 hours minimum. Remove only one specimen at a time from the conditioning environment immediately before testing.

18.6 Procedure

18.6.1 Burner Adjustment

18.6.1.1 If using methane as the burner fuel, ensure that the air supply to the burner is shut off.

18.6.1.2 Open the stopcock in the gas line fully and light the burner.

18.6.1.3 Adjust the needle valve on the burner to give the proper 1.5-inch (38-mm) flame height and remove the flame height indicator.

18.6.2 Test Procedure

18.6.2.1 Insert the specimen fixture with specimen in place into the test cabinet. The bottom of the specimen should be 3/4 inch above the level at the top of the burner. When testing two-sided blankets, the "nap" side (the downy or fuzzy surface of the fabric) should be exposed to the flame.

- 18.6.2.2 Close the cabinet door, and keep it closed during the test.
- 18.6.2.3 The timer must be started immediately upon positioning the burner. Position the burner so that it is directly under the geometric center of the test specimen. This is shown in figure 18-6.

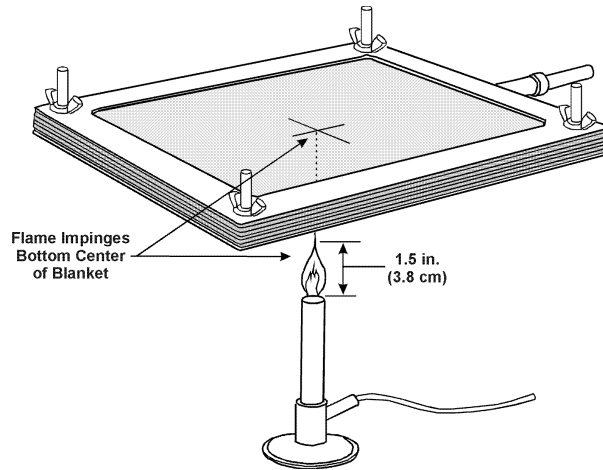

Figure 18-6. Horizontal Test Fixture with Four-Ply Blanket Sample

- 18.6.2.4 Apply the flame for 12 seconds and then withdraw it by moving the burner at least 3 inches (76 mm) from the specimen or by turning the gas off. If the flame extinguishes during the ignition time for any reason, the test will be rerun.
- 18.6.2.5 If flaming material falls from the test specimen, determine the drip flame time for the specimen.
- 18.6.2.6 Determine the flame time for the specimen.
- 18.6.2.7 After all flaming ceases, the cabinet door should be opened slowly to clear the test cabinet of fumes and smoke. The exhaust fan may be turned on to facilitate clearing the smoke and fumes.
- 18.6.2.8 Remove any material that fell from the specimen to the bottom of the cabinet. If necessary, clean the test cabinet window prior to testing the next specimen.

18.7 Report

18.7.1 Material Identification

Fully identify the material tested including fiber type and type of FR treatment, if known.

18.7.2 Test Results

18.7.2.1 Ignition Time

Report the ignition time.

18.7.2.2 Flame Time

Report the flame time for each specimen tested. Determine and record the average value for flame time.

18.7.2.3 Drip Flame Time

Report the drip flame time for each specimen tested. Determine and record the average value for drip flame time. For specimens that have no drips, record zero (0) for the drip flame time and also record "No Drips."

18.8 Requirements

18.8.1 Flame Time

The average flame time for all of the specimens tested will not exceed 15 seconds.

18.8.2 Drip Flame Time

The average drip extinguishing time for all of the specimens tested will not exceed 5 seconds.

Chapter 18 Supplement

This supplement contains advisory material pertinent to referenced paragraphs.

18.3 Since this test method employs the 45-degree test fixture, the test cabinet called out is the cabinet used for 45-degree testing. Suitable test chambers of the type described are manufactured by U.S. Testing Co., 1415 Park Ave., Hoboken, New Jersey 07030; Atlas Electric Devices Co., 4114 N. Ravenswood Ave., Chicago, Illinois 60613; and The Govmark Organization Inc., P.O. Box 807, Bellmore, New York 11710. As stated in the test method, it is permissible to use other draft-free cabinets acceptable to the FAA. One such cabinet is the Horizontal Vertical Flame Chamber manufactured by Atlas Electric Devices (see above for address).

Draft free implies a condition of no air currents in a closed in space. A test cabinet other than one fabricated in accordance with figures 18-1 to 18-3 may be found to be acceptable after review by the FAA. One way of determining whether the cabinet is draft free is to place a smoldering and smoking material, such as a lighted cigarette in the test cabinet, then closing the door and observing the behavior of the smoke for signs of drafts.

The entire inside back wall of the chamber may be painted flat black to facilitate viewing the test specimen.

18.3.2 The specimen holder used is the same holder used for the 45-degree Bunsen burner test with the exception of the mounting stud. Other specimen holders are acceptable provided the test criteria is meet.

18.3.3 A suitable burner is available from Rascher & Betzold Inc., 5410 N. Damen Ave., Chicago, Illinois 60625, Catalog No. R3726A.

If the test cabinet is equipped with a glove box, it is permissible to manually move the burner into test position.

18.3.3.1 A phenomenon that some labs have experienced is a sharp decrease in flame temperature after about three-fourths of the gas originally in the cylinder has been used. This has occurred primarily in labs that have single-stage regulators on their gas cylinders. Single-stage regulators differ from two-stage regulators in that control of the discharge pressure is not as accurate. Few designs should maintain constant or near constant discharge pressures over the full range of cylinder pressures. Therefore, it is necessary to make adjustments periodically to allow for decreasing inlet pressures. Even the slightest drop in pressure can affect the flow rate of gas through the burner orifice. This, in turn, can cause temperature variation. By using a two-stage regulator or adjusting pressure on a single-stage regulator as the cylinder gets low, this problem can essentially be eliminated.

18.3.3.3 The tip of the methane flame is blue, transparent, and difficult to see. It is more easily seen if there is no light on the flame, as in a darkened room. The inner cone of the flame is, however, more visible and easily seen and can be used to monitor flame height. When the flame height (blue transparent tip) is set to 1.5 inches, the height of the inner cone has been found to vary slightly from burner to burner, but is generally about 7/8 inch. Therefore, if the inner cone height is used to monitor flame height, the inner cone height needs to be established for that burner.

18.5 It is recommended that only one specimen be removed at a time from the conditioning chamber prior to subjection to the flame. Some facilities, however, have conditioning chambers located in areas remote from the testing area. In this case, it is permissible to remove more than one specimen at a time if each specimen is covered or carried in a container and protected until the specimen is subjected to the flame.

18.5.1 Industry standard conditioning for textiles is 65 percent relative humidity and 70°F.

18.6.2.2 It is important to note that the test should be watched carefully while it is being conducted. This applies to all samples.

18.6.2.7 The operator should refer to the facility's safety manual for further information dealing with smoke and flammability by-products.

Chapter 19 Smoke Test for Insulated Aircraft Wire

19.1 Scope

This test method is used to determine the smoke generating characteristics of insulated aircraft wire using a smoke density chamber.

19.2 Definitions

19.2.1 Specific Optical Density (D_s)

Specific optical density is a dimensionless measure of the amount of smoke produced per unit area by a material when it is burned. In this test, the maximum value of D_s that occurs during the first 20 minutes of a test, D_m , is reported.

19.3 Test Apparatus

19.3.1 Required Equipment

The test chamber and related equipment (e.g., radiant heat furnace, heat flux density gauge, specimen holder, photometric system, straight pilot burner, etc.) will be as defined below:

19.3.1.1 Test Chamber

The test chamber will be a square-cornered box with inside dimensions of 36 ± 0.13 inches (914 ± 3 mm) wide, 24 ± 0.13 inches (610 ± 3 mm) deep, and 36 ± 0.13 inches (914 ± 3 mm) high. A typical test chamber is shown in figure 19-1. The location or size of items such as the chamber door, chamber controls, flowmeters, etc., is optional, except as mandated in the following sections.

19.3.1.1.1 The interior surfaces (except for the chamber door, vents, etc.) will be porcelain-enameled metal or equivalent coated metal that is resistant to chemical attack and corrosion and suitable for periodic cleaning.

19.3.1.1.2 The chamber will be equipped with a door such as that indicated in figure 19-1 to provide convenient access for changing test specimens and for cleaning the chamber walls as required. The door will have a viewing window to observe the chamber interior during a test, especially when any of the flamelets extinguish.

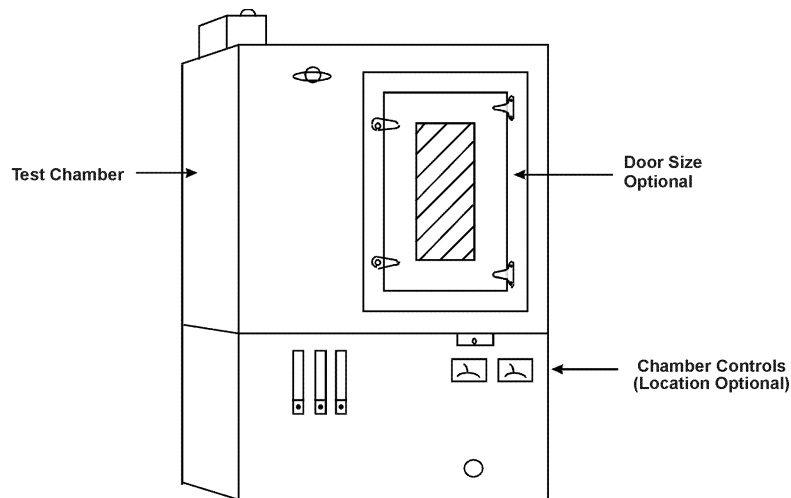

Figure 19-1. Typical Smoke Density Chamber

19.3.1.1.3 An inlet-outlet vent for pressure equalization will be provided. The vent and chamber door will have a seal so that when it is closed during tests, there will be no leakage of chamber contents and a small positive pressure can be developed and maintained inside the test chamber.

19.3.1.2 Manometer

A device such as a manometer or pressure transducer will be provided to monitor chamber pressure and leakage. The device will have a range of up to 6 inches (152 mm) of water and be connected to a suitable port in the test chamber.

19.3.1.3 Pressure Regulator

A pressure regulator will be provided that consists of a water-filled bottle vented to a suitable exhaust system and a piece of tubing, not to exceed 10 feet (305 cm) in length, that has an inside diameter of at least 1 inch (25 mm). One end of the tubing will be connected to a port within 6 inches of the top of the chamber; the other end of the tubing will be held in position 4 inches (102 mm) below the water surface.

19.3.1.4 Test Chamber Wall Thermocouple

The temperature of the test chamber wall will be monitored by a thermocouple suitable for measuring a temperature of 35°C. The thermocouple will be mounted with its junction secured to the geometric center of the inner rear wall panel of the chamber using an electrical insulating disk cover.

19.3.1.5 Electric Power

Six hundred fifty watts of 115V, 60 Hz, single phase electric power will be provided for the radiant heat furnace and accessories. Where line voltage fluctuations exceed 2.5 percent, a constant voltage transformer will be provided.

19.3.1.6 Radiant Heat Furnace

An electric furnace and associated controlling devices, such as shown in figures 19-2 and 19-3, will be provided that are capable of providing a constant thermal flux density of $2.5 \pm 0.05 \text{ W/cm}^2$ ($2.2 \pm 0.04 \text{ Btu/ft}^2/\text{second}$) on the specimen surface.

19.3.1.6.1 Furnace Construction

The dimensions shown in figure 19-2 for the electric furnace are critical. The furnace will be located centrally along the long axis of the chamber with the opening facing toward and approximately 12 inches (305 mm) from the right wall. The centerline of the furnace will be approximately 7.75 inches (197 mm) above the chamber floor.

19.3.1.6.2 Heating Element

The heating element will consist of a coiled wire capable of dissipating about 525 W. With the furnace installed, the heating element will be positioned so that the coil loops are at the 12 o'clock position, as shown in figure 19-3.

19.3.1.6.3 Furnace Control System

The furnace control system will be capable of controlling the radiant heat output at the required level of $2.5 \pm 0.05 \text{ W/cm}^2$ ($2.2 \pm 0.04 \text{ Btu/ft}^2/\text{second}$), as measured by the heat flux density gauge, under steady-state conditions with the chamber door closed for at least 5 minutes. The control system will consist of an AC solid-state voltage or power controller and a voltmeter or other means for monitoring the electrical input.

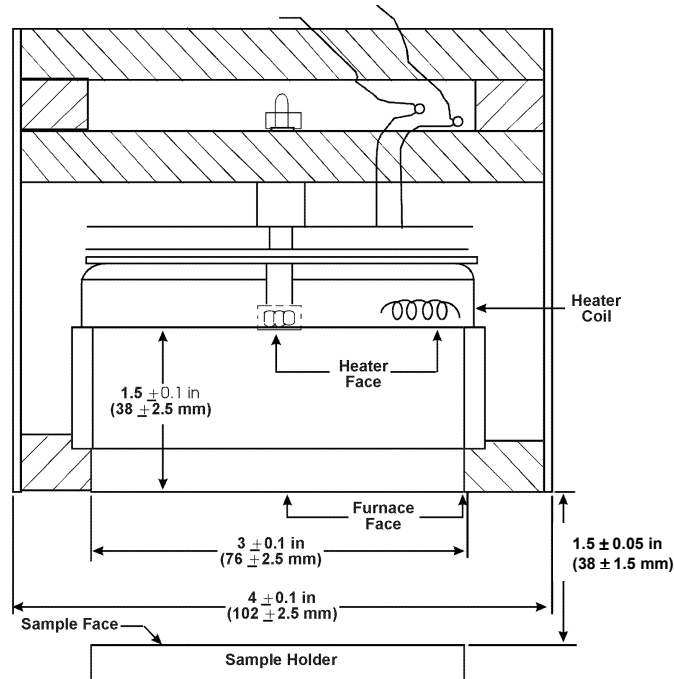

Figure 19-2. Furnace Section

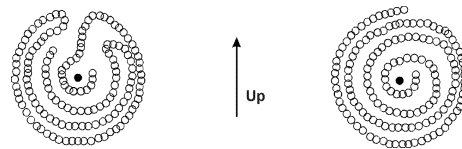

Figure 19-3. Heater Orientation

19.3.1.6.4 Heat Flux Density Gauge

An air-cooled heat flux density gauge will be provided for calibrating the output of the radiant heat furnace. The heat flux density gauge will be a circular foil type, the operation of which has been described by Gardon.

19.3.1.6.4.1 Compressed air at a pressure of 15 to 30 psi (0.1 to 0.21 MPa) will be provided to cool the heat flux density gauge. The body temperature of the heat flux density gauge will be monitored with a thermometer having an accuracy of 2°F (1°C) at 200°F (93°C) in a 0.5- by 0.5- by 1.5-inch (13- by 13- by 38-mm) - long brass or copper well drilled to accept the thermometer with a close fit. Silicone grease will be used to provide good thermal contact. The circular receiving surface of the heat flux density gauge will be spray-coated with an infrared-absorbing black paint. The heat flux density gauge will be calibrated calorimetrically using a procedure that is acceptable to the FAA Administrator.

19.3.1.7 Pilot Burner

The straight burner must be used for flaming tests on insulated wire specimens, as shown in figure 19-4.

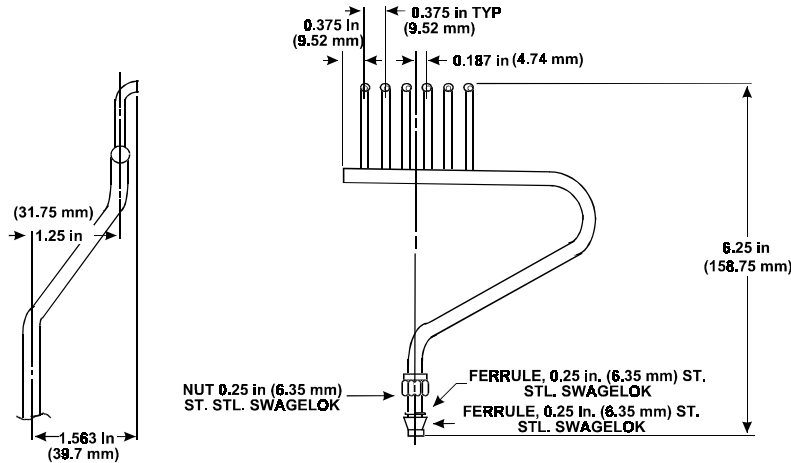

Figure 19-4. Straight Tip Burner

19.3.1.7.1 The six tubes will be fabricated from stainless steel tubing having an outer diameter of 0.125 inch (3.2 mm) and an inner diameter of 0.055 inch (1.4 mm) \pm 0.001 inch (0.025 mm). The six tubes will be attached to a common manifold, as shown in figure 19-5, fabricated from stainless steel tubing having an outer diameter of 0.25 inch (6.4 mm) and a wall thickness of 0.035 inch (0.9 mm). One end of the manifold will be closed, and the other end will be attached to a gas supply fitting on the chamber floor.

19.3.1.7.2 The pilot burner will be centered in front of and parallel to the specimen holder. The tips of the six outer tubes will be placed 0.25 ± 0.06 inch (6.4 ± 1.6 mm) above the lower opening of the specimen holder and 0.25 ± 0.03 inch (6.4 ± 0.8 mm) from the face of the specimen surface.

19.3.1.8 Pilot Burner Fuel

The gas fuel for the pilot burner will be prepared by mixing filtered oil-free air with 95 percent minimum purity propane and feeding the mixture to the pilot burner. Each gas will be metered through separate, calibrated flowmeters and needle valves. The air-propane mixture will consist of an air flow rate equivalent to 0.018 ± 0.001 ft³/min (500 ± 20 cm³/min) at STP and a propane flow rate equivalent to 0.0018 ± 0.0001 ft³/min (50 ± 3 cm³/min) at STP. The compressed air supply will be fed to its flowmeter at 20 ± 5 psi (0.14 ± 0.03 MPa) and the propane at 15 ± 3 psi (0.1 ± 0.02 MPa).

19.3.1.8.1 The visible parts of the pilot burner flamelets should be approximately 0.25 inch (6 mm) long with a luminous inner cone approximately 0.13 inch (3 mm) long, as shown in figure 19-6. If the flamelets are not that approximate size, there is probably a difficulty with the air/propane fuel mixture and/or flow rate(s), in which case, the accuracy of the flowmeters should be checked.

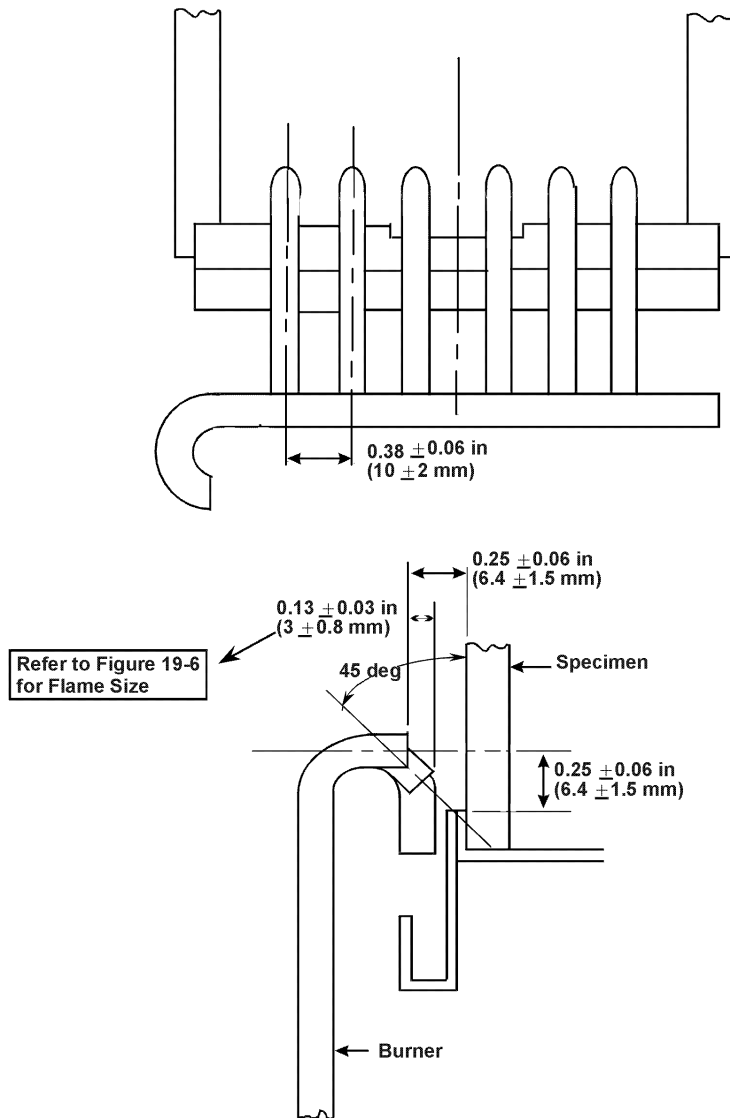

Figure 19-5. Alignment of Holder and Burner

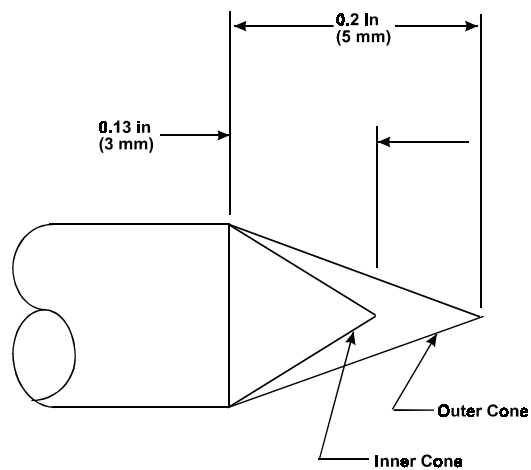

Figure 19-6. Flame Size

19.3.1.9 Specimen Holder

The specimen holder will consist of a stainless steel frame, a backing made of insulation millboard, a spring and retaining rod to secure the specimen in place, and aluminum foil for wrapping the specimen.

19.3.1.9.1 Specimen Holder Frame

The specimen holder frame will be fabricated of stainless steel sheet by bending and brazing (or spot welding) stainless steel sheet of 0.025 ± 0.002 -inch (0.64 ± 0.05 -mm) nominal thickness to conform in shape and dimension to figure 19-7. The frame will be at least 1.5 inches (38 mm) deep and will provide an exposed specimen surface that is nominally 2.56 by 2.56 inches (65 by 65 mm) and that is at least 6.5 inches² ($4,194$ mm²) in area.

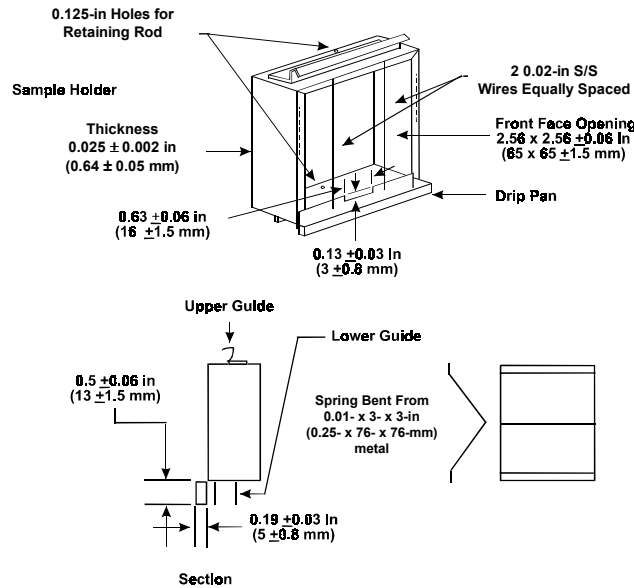

Figure 19-7. Details of Specimen Holder

19.3.1.9.1.1 A drip pan to catch and retain dripping material will be attached to the bottom front of the holder.

19.3.1.9.1.2 Guides to permit accurate alignment of the exposed specimen area in front of the furnace opening will be attached to the top and bottom of the holder frame.

19.3.1.9.2 Specimen Backing

A piece of insulation millboard will be used as a backing for the specimen and as a simulated blank specimen. The millboard will be nominally 0.5 inch (13 mm) thick with a density of 50 ± 10 lb/ft³ (0.8 ± 0.16 g/cm³) or equivalent. Pieces will be cut 2.91 ± 0.03 by 2.91 ± 0.03 inch (74 ± 1 by 74 ± 1 mm) to fit inside the specimen holder.

19.3.1.9.3 Retaining Spring

A spring bent from 3- by 2.94- by 0.01-inch (76- by 75- by 0.25-mm) -thick stainless steel sheet will be used with a stainless steel retaining rod to securely hold the specimen and millboard backing in position during testing.

19.3.1.9.4 Aluminum Foil

Smooth aluminum foil that is 0.0012 ± 0.0005 inch (0.03 ± 0.01 mm) thick will be used to wrap test specimens prior to their insertion in the holder.

19.3.1.10 Support for Radiant Heat Furnace and Specimen Holder

A typical support frame to support the radiant heat furnace and specimen holder is shown in figure 19-8. This support frame will have a provision to establish accurate alignment for the furnace opening so that it is 1.5 ± 0.031 inches (38 ± 1 mm) away from, parallel to, and centered with the exposed specimen surface. Adjustment screws will be provided to align the furnace with reference to the specimen. The framework will have two 0.38-inch (10-mm) -diameter transverse rods of stainless steel to accept the guides of the specimen holder. The rods will support the holder so that the exposed specimen surface is parallel to the furnace opening. Spacing stops will be mounted at both ends of each rod to permit rapid and accurate lateral positioning of the specimen holder. An externally operated control rod will be provided to replace the test specimen with the blank specimen holder in front of the furnace.

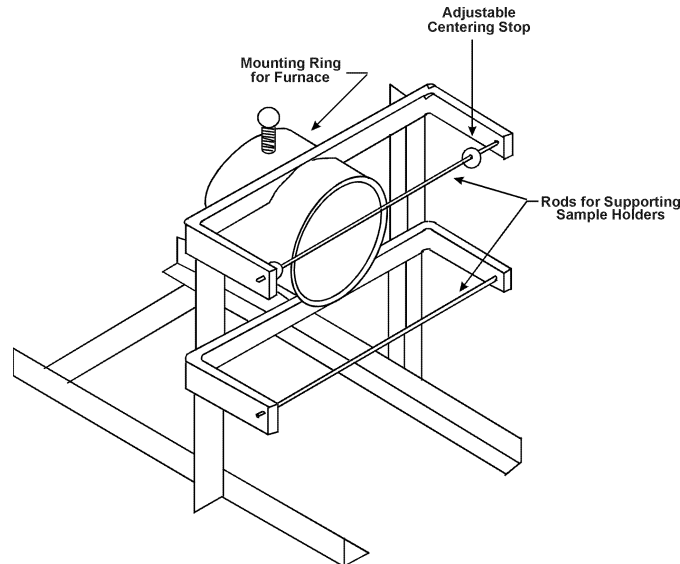

Figure 19-8. Typical Furnace Support

19.3.1.11 Photometric System

A photometric system capable of detecting light transmittance values of 1 percent minimum to an accuracy of 0.03 percent will be provided. The system will consist of a light source and photomultiplier tube that are oriented vertically to reduce measurement variations due optical density, to stratification of the smoke in the chamber during the test, a photomultiplier microphotometer that converts the photomultiplier tube output to relative intensity and/or to and a strip chart recorder or other suitable means to record light transmission versus time. A typical system is shown in figures 19-9 and 19-10.

19.3.1.11.1 Light Source

The light source will be an incandescent lamp mounted in a sealed, light-tight box below the chamber floor and operated at a light brightness temperature of 2200 ± 100 K controlled by a constant-voltage transformer. The box will contain the necessary optics to produce a collimated light beam 1.5 ± 0.13 inches (38 ± 3 mm) in diameter, passing vertically up through the chamber. The light source and its optics will be isolated from the chamber

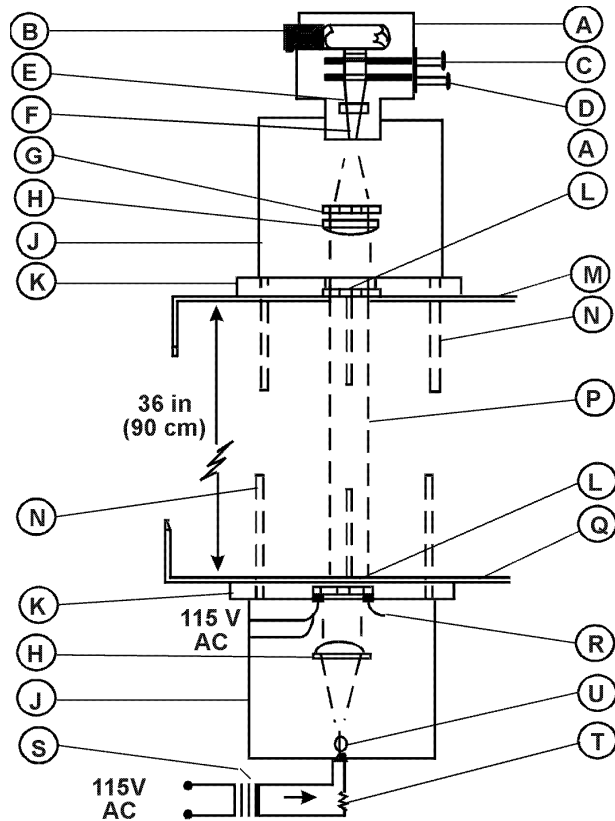

- A - Photomultiplier Housing
- B - Photomultiplier Tube and Socket
- C - Upper Shutter Blade with ND2 Filter over One Aperture
- D - Lower Shutter Blade with Single Aperture
- E - Opal Diffuser Filter
- F - Aperture Disk
- G - Neutral Density Compensating (from set of 9)
- H - Lens 7 Diopter (2)
- J - Optical System Housing (2)
- K - Optical System Platform (2)
- L - Optical Windows (2)
- M - Chamber Roof
- N - Alignment Rods (3)
- P - Parallel Light Beam 1.5 in (37.5 mm) Diameter
- Q - Chamber Floor
- R - Optical Window Heater, Silicone-Fiberglass 50W/115V
- S - Regulated Light Source Transformer, 115/125 V-6 V
- T - Adjustable Resistor, Light Source Adjusted for 4V
- U - Light Source

Figure 19-9. Photometer Detail

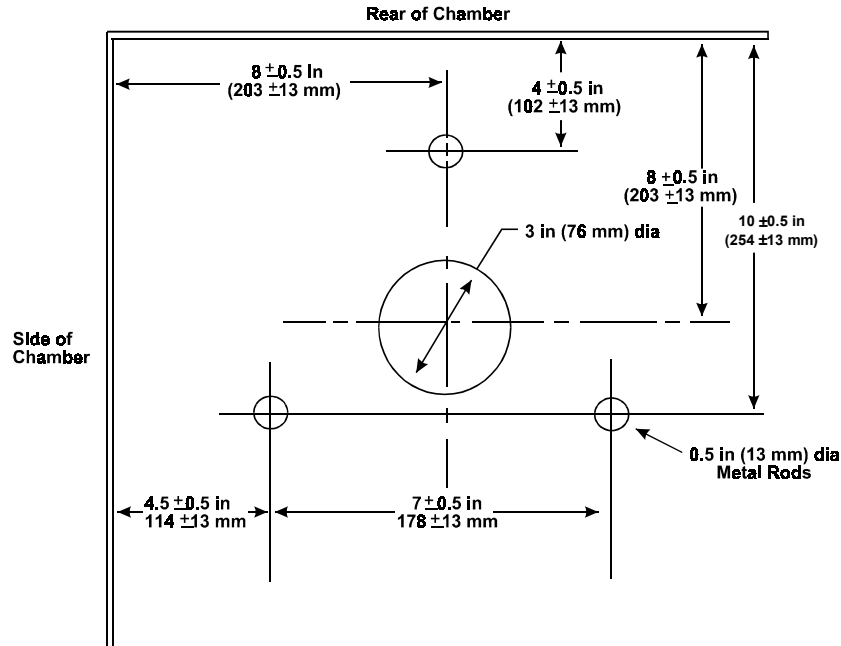

Figure 19-10. Optical System Location Plan View

atmosphere by a glass window that is mounted flush with the chamber bottom panel and sealed to prevent leakage of chamber contents. To minimize smoke condensation, the window will be provided with a ring-type electric heater mounted in the light-tight box, out of the light path, that maintains a minimum window temperature of 125°F (52°C) on the surface of the window inside the chamber.

19.3.1.11.2 Photomultiplier Tube

The photomultiplier tube will have an S-4 linear spectral response and a dark current less than 10^{-9} ampere.

19.3.1.11.2.1 The photomultiplier tube and associated optics will be mounted in a second light-tight box that is located above the chamber ceiling directly opposite the light source. The photomultiplier tube and its optics will be isolated from the chamber atmosphere by a glass window that is mounted flush with the chamber ceiling panel and permits viewing a cross section of 1.5 ± 0.13 inches (38 ± 3 mm). The window will be sealed to prevent the leakage of chamber contents.

19.3.1.11.3 Microphotometer

The microphotometer will be capable of converting the signal from the photomultiplier tube to relative intensity and/or optical density. The microphotometer/photomultiplier tube combination will be sensitive enough that the microphotometer can be adjusted to produce a full-scale reading (100 percent relative light intensity or optical density = 1) using the photomultiplier tube's response (output) to the light source when a filter of 0.5 or greater optical density is placed in the light path.

19.3.1.11.4 Alignment Fixture

The two optical windows and their housings will be kept in alignment and spaced 36 ± 0.125 inches (914 ± 3 mm) apart with an alignment fixture consisting of three metal rods, 0.5-0.75 inch (13-19 mm) in diameter fastened securely to 0.31-inch (8-mm) -thick externally mounted top and bottom plates and symmetrically arranged about the collimated light beam.

19.3.1.11.5 Optical Filters

A set of nine neutral color optical filters—0.1, 0.2, 0.3, 0.4, 0.5, 0.6, 0.7, 0.8, and 0.9 optical density—will also be provided. The optical filters, one or more, as required, may be mounted in the light path in the optical measuring system to compensate for the sensitivity of the photomultiplier tube. These filters can also be used to adjust the photometric system as the light source and/or photomultiplier tube changes sensitivity through aging and/or as discoloration or deterioration of the optical windows occurs.

19.3.1.11.6 Recorder

A recording device will be furnished that provides a record of the percent of light transmission and/or optical density versus time during the test. The record will consist either of a continuous curve on a chart recorder or discrete values taken at least every 5 seconds with a computerized data acquisition system.

19.3.1.12 Exhaust Hood

A method for removing the chamber contents after each test will be provided. A fitting for removing the chamber contents can be connected to a suitable exhaust hood. Locating an exhaust hood directly above the smoke chamber door is recommended as an additional safety device.

19.3.1.13 Conditioning Chamber

A conditioning chamber capable of maintaining test specimens at a temperature of $70 \pm 5^\circ\text{F}$ ($21 \pm 3^\circ\text{C}$) and $50\% \pm 5\%$ relative humidity will be provided.

19.4 Test Specimen Selection and Preparation

19.4.1 Specimen Number

A minimum of three specimens will be prepared and tested.

19.4.2 Specimen Size

Insulated wire specimens, 16 AWG and smaller, will be wrapped on the frame, as shown in figure 19-11. Insert the end of a 10-foot length of insulated wire through one of the holes in the frame and complete the wrap by inserting the finishing end of the insulated wire through the unused hole and under the last turn to prevent unwinding. Specimens, 14 AWG and larger, should be cut approximately 3 inches in length and laid side by side, covering the entire opening in the front of the specimen holder. This is readily accomplished by first covering the front of the Marinite millboard with aluminum foil and inserting it and the spring into the specimen holder. The pieces of wire are then inserted through the front of the holder and held vertically. This is shown in figure 19-12.

19.4.3 Specimen Orientation

Insulated wire specimens will only be tested in a vertical orientation.

19.5 Test Chamber Calibration

19.5.1 Furnace Protection

Prepare a blank specimen consisting of 0.5-inch-thick alumina-silica millboard mounted in a specimen holder (see section 6.3.1.9.2). To reduce problems with the stability of the heat flux density from the furnace, maintain the blank specimen in front of the furnace when no testing or calibration is being conducted.

19.5.2 Periodic Calibration Procedure

Conduct a periodic calibration of the system as follows.

19.5.2.1 Photometric System

The photometric system used in this test method is an inherently linear device. Check the system for proper photocell alignment. Verify, at least every 2 months, the linearity of the system using a set of neutral optical density filters or equivalent. If erratic behavior is observed or suspected, check the system more frequently.

19.5.2.2 Furnace

Use the approved heat flux density gauge to monitor the heat flux density produced by the furnace. Place the heat flux density gauge on the horizontal rods of the furnace support framework and accurately position it in front of the furnace opening by sliding and displacing the blank specimen holder against the spacing stop (see section 6.3.1.10). With the chamber door closed and the inlet vent opened, adjust the compressed air supply to the heat flux density gauge cooler to maintain its body temperature at $200 \pm 50^\circ\text{F}$ ($93 \pm 3^\circ\text{C}$). Adjust the setting of the furnace control voltage or power controller to obtain the calibrated millivolt output of the heat flux density gauge corresponding to a steady-state irradiance of $2.5 \pm 0.05 \text{ W/cm}^2$ ($2.2 \pm 0.04 \text{ Btu/ft}^2/\text{second}$). After the irradiance has reached the required value and has remained steady state for at least 5 minutes, remove the heat flux density gauge from the chamber and replace it with the blank specimen holder.

19.5.2.2.1 Record the setting of the furnace control voltage or power controller and use this setting until a future calibration indicates it should be changed.

19.5.2.3 Chamber Leak Test

Test the smoke density chamber leak rate at least once a month or more often if loss of chamber pressure is suspected, using the following procedure.

19.5.2.3.1 Place the heater switch in the OFF position. Close the inlet vent and the chamber door.

19.5.2.3.2 Pressurize (e.g., by bleeding in a small amount of air through the port used for the heat flux density gauge) the chamber to at least 3 inches of water above ambient as indicated by the manometer.

19.5.2.3.3 Note the chamber pressure. Verify that the chamber pressure leakage rate is less than 2 inches of water in 2 minutes.

19.5.2.4 Total System

Check the total system at least once a month by testing a material that has shown a consistent specimen-to-specimen D_m value in the range of 1 to 5 D_m and that is and will continue to be readily available. Maintain a record of the test results obtained; if erratic values are observed, identify and correct any instrumental or operational deficiencies.

19.5.3 Chamber Cleaning

Clean the optical system windows, viewing window, chamber walls, and specimen holders as follows.

19.5.3.1 Optical System Windows

Clean the exposed surfaces of the glass separating the photo detector and light source housings from the interior of the chamber after each test. Clean the top window first, then the bottom window, using a nonabrasive cloth dampened with a suitable cleaner. Dry the window to prevent streaking or film buildup. Do not use any cleaners that contain wax because wax will cause the smoke to adhere to the glass more quickly.

19.5.3.2 Viewing Window

Clean the viewing window periodically as required to allow viewing of the chamber interior during testing. The same cleaners used in section 6.6.3.1 have been found satisfactory.

19.5.3.3 Chamber Walls

Clean the chamber walls periodically to prevent excessive buildup of smoke products. An ammoniated spray detergent and nonabrasive scouring pad have been found effective.

19.5.3.4 Specimen Holders

Remove any charred residues on the specimen holders and horizontal rods securing the holder position to prevent contamination of subsequent specimens.

19.6 Procedure

19.6.1 Each day, prior to testing, adjust the chamber as follows.

19.6.1.1 Calibrate the furnace output according to section 6.6.2.3 to determine the correct furnace voltage.

19.6.1.2 Balance the photomultiplier dark current and set the clear beam reading to 100 percent relative transmission or to optical density 0.00.

19.6.1.3 Set the photomultiplier scale at 100. Shut lower shutter blade (D) directly below photomultiplier tube (B) (see figure 19-9). Set your data recording device to zero.

19.6.2 Conduct the test procedure as follows.

19.6.2.1 Ensure that the specimen(s) have been properly prepared per sections 6.4.1 through 6.4.5.

19.6.2.2 Ensure that the chamber wall temperature is $95 \pm 4^{\circ}\text{F}$ ($35 \pm 2^{\circ}\text{C}$).

19.6.2.3 Ensure that the furnace voltage has been set correctly.

19.6.2.4 Set the clear beam reading to 100 percent relative transmission or to optical density 0.00 (see section 6.7.1.2).

19.6.2.5 Position the pilot burner in front of and parallel to the specimen holder. Turn on the pilot burner fuel (see section 6.3.1.8) and light the flamelets on the pilot burner. Make sure that all flamelets are ignited and properly adjusted.

19.6.2.6 Open the test chamber door and place the specimen holder on the support. Immediately push the specimen holder into position in front of the furnace, displacing the blank specimen holder to the repositioned stop, and close the chamber door and inlet vent. For chambers with an external device to move the specimen holder in front of the furnace, place the holder on the support close the door, and then slide the sample into position and simultaneously start the timer and recorder for light transmission.

- 19.6.2.7 Continue the test for a minimum of 20 minutes (1200 seconds).
- 19.6.2.8 Record the percent of light transmission and/or optical density versus time (minutes) during the test.
- 19.6.2.9 Monitor the chamber pressure during the test. If negative pressure (below ambient atmospheric) develops, open the inlet valve slightly to relieve pressure.
- 19.6.2.10 If one or more pilot lights extinguish at the start of the test (first 5 seconds), stop the test, relight the flames, and start the test again. If one or more pilot lights extinguish during the first 10 minutes of the test, the test must be aborted and a new sample of wire run. If one or more pilot lights extinguish after 10 minutes, continue the test, making note of the time of extinguishment and the number of pilot lights extinguished.
- 19.6.2.11 At the termination of the test, remove the test specimen holder from its position in front of the furnace and replace it with the blank specimen holder using the exterior control rod. Begin exhausting the chamber of smoke within 1 minute by opening the door and the inlet vent (and exhaust vent, if used).
- 19.6.2.12 Continue to exhaust the chamber until all smoke has been removed.
- 19.6.2.13 Clean the windows to the housings for the photomultiplier tube and the light source per section 6.6.3.1.
- 19.6.2.14 Record the D_s for each specimen at the 20-minute point. Calculate and record the maximum specific optical density, D_m , during the 20-minute (1200-second) test for each specimen according to the formula:

$$D_m = (V / LA) \log_{10}(100 / T_m)$$

$$= 132 \log_{10}(100 / T_m)$$

where:

V = chamber volume = 18.00 ft³ (0.510 m³)

L = light path length = 3.00 ft (0.914 m)

A = exposed specimen area = 6.57 in² (0.00424 m²)

T_m = minimum percent light transmission during 20 minutes

$\log_{10}(100/T_m)$ = maximum optical density during 20 minutes

- 19.6.2.15 Calculate and record the average D_m value and its standard deviation for all the specimens tested for each part/construction. Use the actual D_m values for this average; do not use the average light transmission value to determine the average D_m value.

19.7 Report

- 19.7.1 Report a complete identification of the part/construction tested such as insulation type, gauge, etc.
- 19.7.2 Report the number of specimens tested (the average D_m).
- 19.7.3 Report any additional data or observations, as applicable and/or required by the test plan.

Chapter 19 Supplement

This supplement contains advisory material pertinent to referenced paragraphs.

19.2.1 In this test, the maximum specific optical density ($^{20}D_s$) should be at 20 minutes; however, due to coagulation of smoke particles or to adsorption of smoke particles to the walls of the chamber, it is possible for the maximum to occur earlier in the test.

19.3 Recommended Equipment

The following items are recommended, but not required:

Digital Voltmeter—Preferred to monitor furnace voltage and heat flux density gauge output. A Keithley Model 165 Autoranging Multimeter or equivalent has been found acceptable.

Constant Voltage Transformer—A constant voltage transformer is recommended for all installations (see section 19.3.1.5).

Pilot Burner Positioning Fixture—A fixture to accurately position the pilot burner is recommended to establish a precise pilot burner position for testing and to facilitate accurate repositioning of pilot burner after removal and replacement (see figure 19-10).

Automated Igniter System—An automated igniter system is recommended to relight the pilot burner flamelets to ensure that none of them extinguishes for more than 3 seconds during the test. If an electric sparking device is used, an appropriate method of suppression and equipment shielding must be applied to have no interference with ability of data acquisition equipment to accurately record data. Weyerhaeuser Fire Technology Laboratory, Report #9001-in house, describes an automated sparking system. Another system for reignition utilizes a small movable propane flame.

19.3.1.1 Commercially available panels of porcelain-enameled steel (interior surface) permanently laminated to a magnesia—insulation core and backed with galvanized steel (exterior surface)—have been found acceptable.

A thin sheet of transparent material can be placed over optical and viewing windows to protect them against corrosive components in the smoke.

19.3.1.3 Venting the water filled pressure regulator to a suitable exhaust system is necessary to prevent the buildup of unknown contaminants in the laboratory area. The location of the pressure relief tube should be on or within 6 inches of the top of the chamber.

19.3.1.5 A powerstat variable autotransformer, Type 21, from Superior Electric Co., Bristol, Connecticut, or equivalent, has been found satisfactory to transform electric power to that required by the chamber.

A constant voltage transformer from Sola Electric Co., Chicago, Illinois, Catalog Number 23-13-150, or equivalent, has been found satisfactory. A Sorenson Model 200S AC voltage regulator or equivalent has been found satisfactory.

19.3.1.6 Furnace model P/N 6806025700 from Newport Scientific has been found acceptable.

19.3.1.6.3 A Model 470 Series power controller manufactured by Eurotherm, a Model 3AEV1B10C1 Triac manufactured by General Electric Company, or equivalent has been found satisfactory.

The furnace control system should be a reputable unit that provides the parameters to fulfill the requirements of the furnace.

It is recommended to use a digital voltmeter to monitor the furnace voltage output and a digital amperemeter to monitor the furnace current.

19.3.1.6.4 A thermocouple system capable of measuring $200 \pm 2^\circ\text{F}$ is an acceptable alternate method to monitor the body temperature of the heat flux density gauge. See Gardon, R., "An Instrument for the Direct Measurement of Intense Thermal Radiation," *Review of Scientific Instruments*, Vol. 24, 1953, pp. 360-370.

19.3.1.7 The pilot burner should be aligned with a sample holder and backing board in place. A description of a suitable method of alignment is shown in figure 19-10. Care should be taken to ensure accurate positioning of the pilot tips to the sample holder.

19.3.1.8 Commercially bottled propane has been found acceptable.

19.3.1.9.1 Sample holders must be checked for accuracy with each other; for example, top and bottom mounting devices consistent with each other. It has been noted that misalignment between holders does result in pilot position errors.

19.3.1.9.2 A recommended material is Marinite I.

19.3.1.9.4 Aluminum foil used for household food wrapping is acceptable.

19.3.1.11.2 A thin sheet of transparent material can be placed over optical and viewing windows to protect them from corrosive components in the smoke.

19.4.1 Conditions may require as many as six specimens. Specimens should be marked with an arrow by manufacturers or operator for a consistent direction for test purposes.

19.6.1.3 During recent testing at the FAA William J. Hughes Technical Center, a problem has been discovered with the calculation of D_s during some NBS chamber testing. The problem is software related. It is possible that during the initial readings taken with a blanked off photcell, there should be some residual voltage reading (± 1 millivolt). This is too small a value to be read visually, but can be detected by the computer. The problem is that the current software assumes the initial value is zero and the results are altered accordingly. Because the specific optical density is a logarithmic function, the problem is magnified the higher the value, making the D_s around the pass/fail point of 200 critical. A \pm millivolt initial reading can change an actual D_s of 200 to 175/224, respectively. The fix for this problem is to blank off the photocell prior to each test and let the computer set the "zero."

Computer users could use the following procedure for the computer program: Close the shutter, let the computer read baseline volts (0) (mV_b), and determine:

$$\text{Slope} = \frac{100}{(mV_H - mV_b)}$$
$$\%L.T. = (mV - mV_b) * \text{Slope}$$

CAUTION: The door should be opened gradually to avoid exposure to the chamber contents, which may be toxic.

19.6.2.4 This procedure is described in AMINCO NBS Smoke Density Chamber, Catalog No. 4-5800B, Instruction 941B.

19.6.2.13 Ethyl alcohol, methyl ethyl ketone, or equivalent has been found satisfactory.

Chapter 20 Dry Arc Tracking Test Procedure

20.1 Purpose

The Dry Arc Tracking Test for wire insulation provides a comparative assessment of insulation degradation and arc propagation of wires in a bundle when subjected to electrical arcing. This test method is for use in obtaining comparative data.

20.2 Test Specimens

Twenty-gauge wires were selected as test standards, since this size is one of the most commonly used gauges in transport category aircraft. At least three tests must be run on each wire insulation material.

20.2.1 Specimen (Preparation)

Cut seven segments of wire, each 14 inches in length. Strip 3/16 inch of insulation from both ends of each wire.

20.2.1.1 Assemble the wires in a 6 around 1 configuration, as shown in figure 20-1.

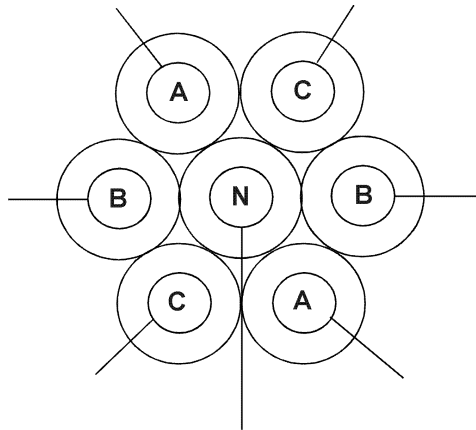

Figure 20-1. Wire Bundle Configuration

20.2.1.2 Arrange the wires straight and parallel. Using a high-temperature lacing tape, mil-tie the wires into a bundle, making a tie 1/4 inch back on the insulation from one set of stripped ends. The other ends are left untied to better facilitate connecting to test leads from a power supply. Make a second tie 2 inches farther back from the first tie. After tying the bundle, apply a small amount of finely powdered conductive graphite to the exposed wire ends (Graphite, 96 percent, 325 Mesh Technical, J.T. Baker, Inc., is acceptable). This can be accomplished by dipping the wire ends directly into a container of the graphite powder. Ensure that the graphite does not get on the wire insulation.

20.2.2 Electrical Connections

Support the bundle horizontally in a laboratory stand using two clamps, approximately 8 inches apart. Position one clamp 1/2 inch from the bundle tie farthest in from the graphite powdered wire ends. The other clamp is used to support the wires toward the end that is connected to the power supply.

20.2.2.1 Connect each of the seven 20-gauge wires to a 7.5-amp aircraft circuit breaker. (This size conforms to standards for circuit breaker protection of bundled 20-gauge airplane wiring.) The 7.5-amp breakers can be mounted in a test box with alligator clips on seven test leads to facilitate connecting to the test wires. Use a three-phase Wye connected power supply

derived from a rotary machine of not less than 5 KVA rating, delivering 215 volts line-to-line at 400 cycles (see figure 20-2).

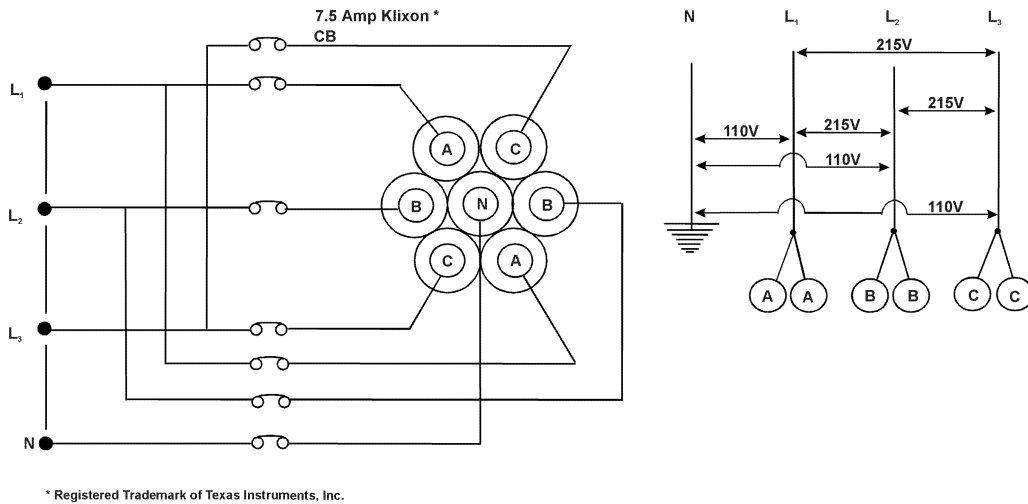

Figure 20-2. Electrical Connections

20.2.3 Protective Screen and Test Location

A transparent screen should be used to protect personnel from molten metal and other debris that may be ejected from the specimen during the arc test. Use eye protection for visual observation of the arc. Conduct the test in a ventilated, draft-free location to remove any potentially toxic fumes. Perform testing at room temperature.

20.3 Procedure

Initiate the test arc by closing a power contactor. Then, leaving the contactor closed, visually examine, but do not touch, the wires in the bundle after the initial arc. Following that, reset each tripped circuit breaker one time only.

20.4 Report

Report the following for each test:

1. A description of the wire tested
2. The power, frequency, and voltage of the three-phase power supply
3. Any damage to the wire bundle after the initial arc
4. The number of open circuit breakers after the initial arc
5. A description of damage to the insulation of each wire in the bundle, including the length of insulation damage, tube effects, welds, etc., after resetting the circuit breakers

Chapter 21 Dry Arc-Propagation Resistance

21.1 Purpose

The Dry Arc-Propagation Resistance Test for wire insulation provides an assessment of the ability of an insulation to prevent damage in an electrical arc environment. In service, electrical arcs may originate from a variety of factors, including insulation deterioration, faulty installation, and chafing. It has been documented that results of an arc-propagation test may vary slightly due to the method of arc initiation. Therefore, a standard test method must be selected to evaluate the general arc-propagation resistance characteristics of an insulation. This test method initiates an arc with a vibrating blade. The arc-propagation resistance is defined by the length of arc-propagation damage along the wires in contact with the blade and by the extent of damage to all adjacent wires undamaged by the vibrating blade. The test also evaluates the ability of the insulation to prevent further arc-propagation when the electrical arc is re-energized. The power supply, test current, circuit resistances, and other variables are optimized for testing 20-gauge wires. The use of other wire sizes may require modification of test variables.

21.2 Test Equipment

The following equipment shall be used.

- 21.2.1 An abrader blade made from 6061-T6 aluminum material. Use a 60-grit size grinding wheel or a 60-grit sanding belt to sharpen the blade. A typical abrader blade is shown in figure 21-1. Use the blade sharpening fixture shown in figure 21-2.

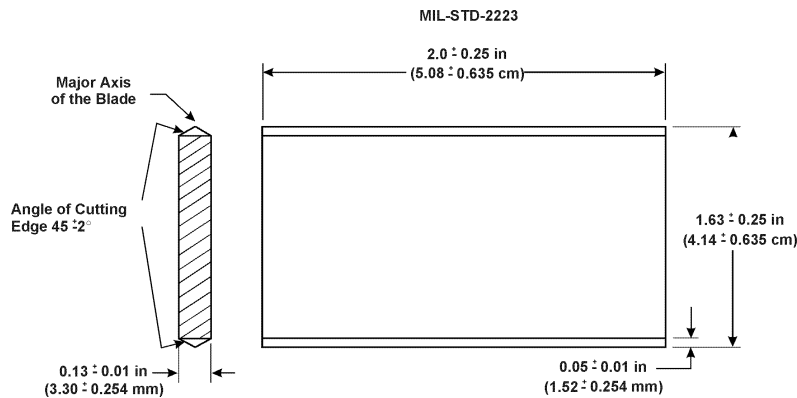

Figure 21-1. Typical Abrader Blade

- 21.2.2 A transparent screen to protect laboratory personnel from molten metals, UV radiation, and other debris that may be ejected from the test specimen.
- 21.2.3 An oscillating mechanism to which the abrader blade is connected. The oscillating mechanism will provide a stroke of 3.81 cm (1.5 inches) at a frequency of 0.5 ± 0.05 cycles per second.
- 21.2.4 A test fixture that includes a test block to hold the wire at right angles to the abrading blade. The block is made from 6061-T6 aluminum.
- 21.2.5 A three-phase Wye connected power supply, grounded at Wye, derived from a rotary machine or solid-state power supply of not less than 20 KVA rating, delivering 208 volts line-to-line at 400 Hz.
- 21.2.6 A mechanical stop constructed of stainless steel.
- 21.2.7 MS3320-7.5 (7.5 amp) and MS25244-50 (50 amp) protective circuit breakers.
- 21.2.8 Variable load and fixed load resistors.

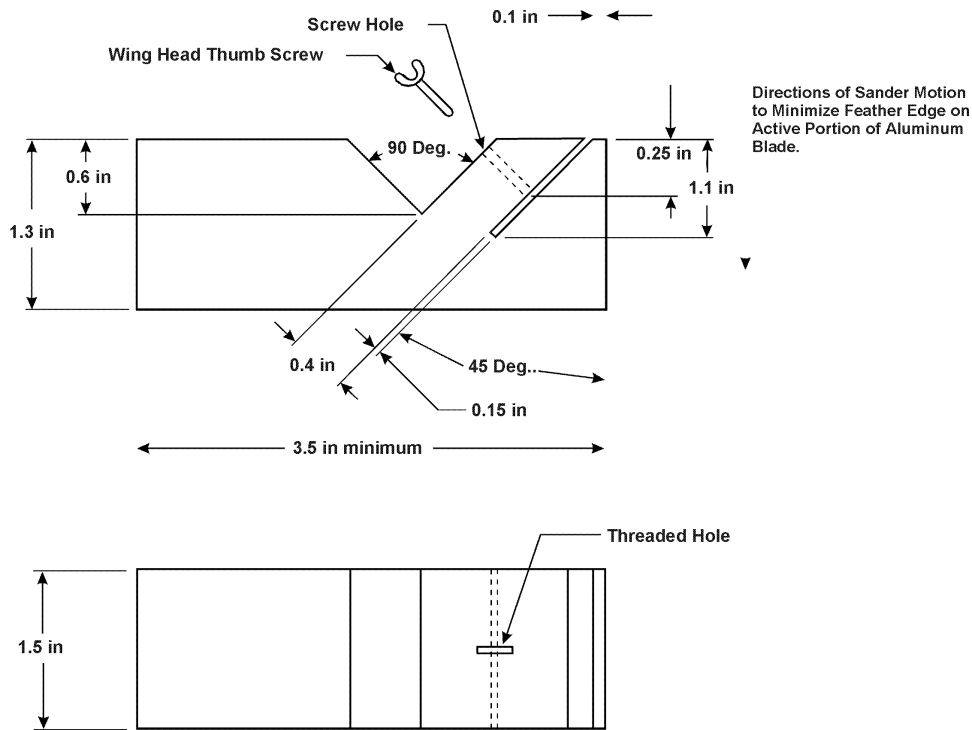

Figure 21-2. Aluminum Blade Sharpening Fixture

21.2.9 MIL-T-43435 (Type V) lacing tape.

21.2.10 MS25231 plastic clamps.

21.3 Test Samples

A test sample will consist of 15 bundles of wire. Each bundle is composed of seven wires and will be of sufficient length, 35.6 cm (14 inches) minimum, to allow the bundle to be installed in the test fixture. A minimum of 37.3 meters (122.5 feet) of wire is required. It is recommended that 20-gauge wire be used for the test.

21.4 Procedure

21.4.1 Preparation of Bundles

Conduct a 2500 volt Wet Dielectric test on 100 percent of the wire in accordance with the Wet Dielectric test procedure described in MIL-STD-2223, method 3005, before the arc-propagation resistance test is performed. Discard any failed sections of wire. Cut seven wire segments at least 35.6 cm (14 inches) in length for each of the 15 bundles. Clean the cut wires using a cloth saturated with Isopropyl alcohol. Strip both ends of five of the seven-wire segments. Use these stripped ends for making electrical connections. These five-wire segments will be called “active wires.” Form the bundle by laying the seven segments straight and geometrically parallel. Assemble the wires to form the six-around-one configuration shown in figure 21-3. Use MIL-T-43435 lacing tapes to hold the test bundle together. Clean the assembled bundle using a cloth saturated with Isopropyl alcohol prior to installation in the test fixture.

21.4.2 Bundle Installation

A test fixture will be used to hold the wire bundle in place perpendicular to the abrader blade. Details of a suggested test fixture are shown in figure 21-4. Before installation, the wire bundle will be tied with MIL-T-43435 lacing tape at 0.635 cm (0.25 inch) on each side of where the abrader

MIL-STD-2223

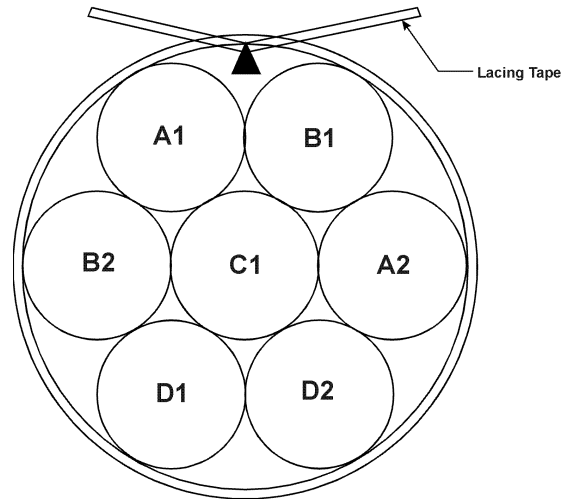

Figure 21-3. Bundle Configuration

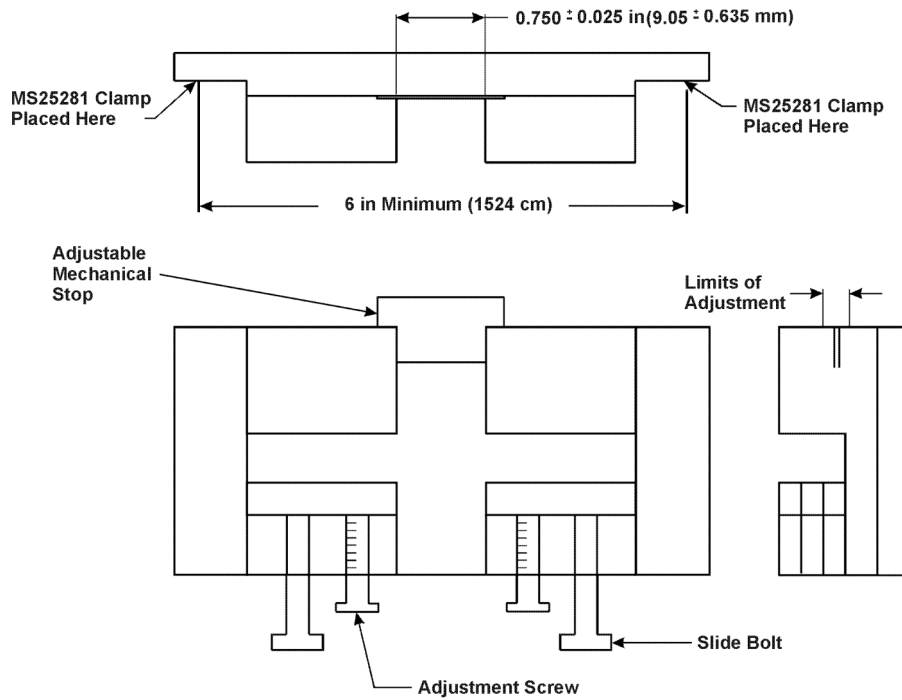

Figure 21-4. Test Fixture

blade is to be applied; then secured to the test fixture. The wire bundle is clamped with MS25281 plastic clamps at two points on the fixture at a minimum distance of 15.24 cm (6 inches). The clamp points are equidistant from the point of application of the abrader. The slide bolt allows the adjusting screw to move the holding plates snugly against the bundle. Ensure that the active wires A1 and B1 are parallel with the top plane of the test fixture and that the passive wires D1 and D2 are in complete contact with the base of the test fixture. The bundle must not be allowed to move while

the abrader blade is cutting wires A1 and B1. The test fixture will contain an adjustable mechanical stop, which may be set to allow for various penetration depths of the vibrating blade.

21.4.3 Electrical Connection

Connect the test bundle to the power supply and circuit resistance using the schematic circuit shown in figure 21-5. Connect one end of each active wire to the appropriate phase of the power supply, as shown in table 21-1. Use an MS3320-7.5 (7.5 amp) circuit breaker and a circuit resistance in series with each of the active wires. Use the circuit resistance values shown in table 21-2. Connect the other end of the five active wires under test to variable resistance loads. Adjust the resistance to limit the current flowing through each wire to 1 ± 0.2 ampere. Protect the test circuits with MS25244-50 (50 amp) circuit breakers connected on the supply side of the test setup. Connect the abrader blade to the neutral of the generator. Connect the generator neutral to ground.

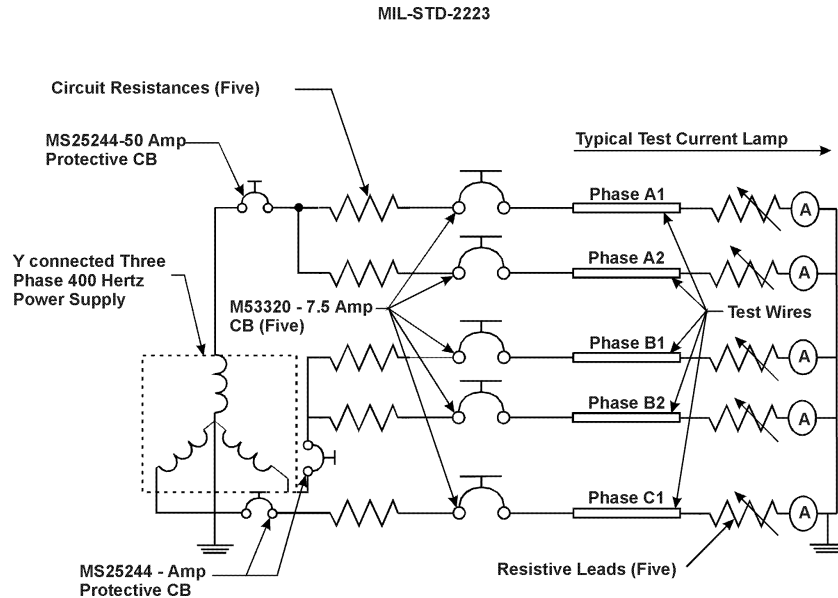

Figure 21-5. Electrical Connection

Table 21-1. Electrical Connection

Wire Identification	Power Supply	Layer
A1	Phase A	Top
B1	Phase B	Top
C1	Phase C	Middle
A2	Phase A	Middle
B2	Phase B	Middle
D1	None	Lowest
D2	None	Lowest

Table 21-2. Circuit Resistance

Test Number	Circuit Resistance (ohm)
1	0.0
2	0.5
3	1.0
4	1.5
5	2.0

21.4.4 Initiation of Test

Test three bundles for each of the five circuit resistances. Install the oscillating mechanism, which may use a reciprocating arm or vertical and horizontal precision linear ball-slides (a suggested ball-slide apparatus is shown in figure 21-6). Adjust the mechanical stop to ensure that the abrader blade penetrates into the A1 and B1 wires a distance of 0.87 times the radius of the seven wire bundles. Close all circuit breakers. Apply a nominal load of 250 grams (0.551 pounds) to the abrader at the point of contact with one wire. Adjust the blade to ensure that the major plane of the blade lies perpendicular to the longitudinal axis of the bundle. Apply the abrader blade on the test bundle. Position the protective screen to shield the operator from ejecting objects and UV radiation. Apply three-phase, 400 Hz power. Actuate the abrader. Allow the abrader blade movement to continue.

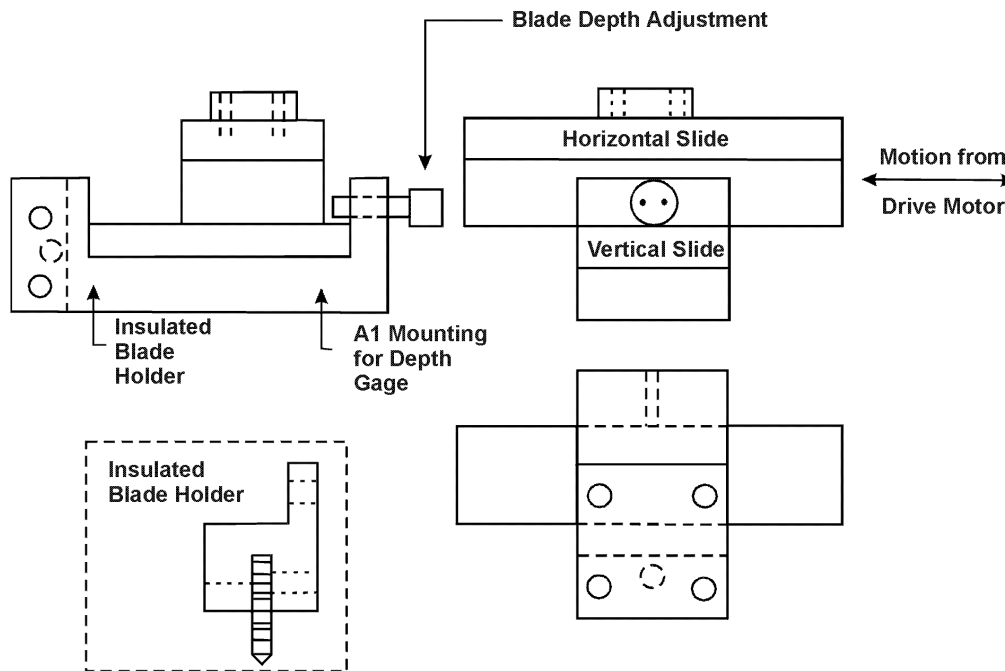

Figure 21-6. Ball-Slide Blade Fixture

21.5 Results

Use one of the following conditions to conduct and complete the test.

- 21.5.1 If the abrader cuts through A1 and B1 wires without tripping phase A1 or phase B1 circuit breakers, stop the abrader movement. Disconnect the power.
- 21.5.2 Conduct the 1000 volt Wet Dielectric test on wires A2, B2, C1, D1, and D2 in accordance with the Wet Dielectric procedure of MIL-STD 2223, method 3005. Record the number of wires that fail. Measure and record the total length of physical damage to each wire (including phase A1 and B1 wires) in inches.
- 21.5.3 If a circuit breaker in any of the phases A2, B2, or C1 trips at any time during the test, stop the abrader and disconnect the power. Perform tests as listed in 21.5.2.
- 21.5.4 If either phase A1 or phase B1 circuit breaker trips at any time during the test, stop the abrader. Disconnect the power and determine if the conductor wires A1 or B1 are open. If both wires are open, conclude the test by performing tests as listed in 21.5.2. If wire A1 or wire B1 are not open, wait 3 to 4 minutes, reset the circuit breaker, restart the abrader, and then immediately reapply the power. Continue the test until either phase A1 or phase B1 circuit breaker has tripped a second time,

phases A1 and B1 are open, or the blade movement is stopped by the mechanical stop. CAUTION: DO NOT RESET A CIRCUIT BREAKER THAT TRIPS TWICE. Perform the tests as listed in 21.5.2. Use a new abrader blade edge for each test bundle if any damage is present or if circuit breakers A1 or B1 trip during the test.

- 21.5.5 Circuit breakers should be periodically tested to ensure they still meet the overload requirements of the applicable military specification sheet. Circuit breakers outside their overload trip requirements should be replaced.

21.6 Information Required in the Individual Specification

Specifications will list the minimum number of wires that must pass the dielectric test after the bundle has been energized and, also, the maximum allowable length of physical damage to the individual wires in the bundle.

Chapter 22

Cotton Swab Test for Thermal Acoustic Insulation Blankets

22.1 Scope

This nonregulatory, industry screening test is intended for use in determining the resistance of thermal acoustic insulation films to flame propagation when tested with alcohol dipped cotton swabs.

22.2 Definitions

22.2.1 Burn Length

Burn length is the distance from the original specimen edge to the farthest evidence of damage to the test specimen due to that area's combustion, including areas of partial consumption, charring, or embrittlement but not including areas sooted, stained, warped, or discolored nor areas where material has shrunk or melted away from the heat source.

22.3 Test Apparatus

22.3.1 Test Area

Tests will be conducted in a draft-free enclosure. It is suggested that the enclosure be located inside an exhaust hood to facilitate clearing the enclosure of smoke after each test.

22.3.2 Fuel

Isopropyl alcohol will be used as the flammable solvent.

22.3.3 Ruler

A ruler or scale graduated to the nearest 0.1 inch (2.5 mm) will be provided to measure the burn length.

22.3.4 Cotton Swabs

Two cotton tipped applicators (equivalent to Q-tips single-tipped applicators) will be used as the ignition source vehicle. The wooden sticks must be removed before placement on the test samples.

22.4 Test Specimens

22.4.1 Specimen Size

The specimen will be a rectangle at least 16 by 24 inches (406.4 by 609.6 mm).

22.4.2 Specimen Fabrication

Fabricate a test blanket using insulation batting intended for use in the aircraft and the candidate film cover material. The test blanket must be sealed around the perimeter. This may be accomplished by heat sealing, sewing, or using flame-resistant approved tape.

22.4.3 Make sure that the test blanket is vented. This can be accomplished by puncturing the blanket with a small object such as a pin.

22.4.4 Specimen Number

One specimen will be prepared and tested.

22.4.5 Specimen Thickness

The specimen thickness will be the same as the part qualified for use in the airplane.

22.5 Test Procedure

22.5.1 Prop the test blanket against a nonflammable surface in the position shown in figure 22-1. Make sure that the orientation is correct.

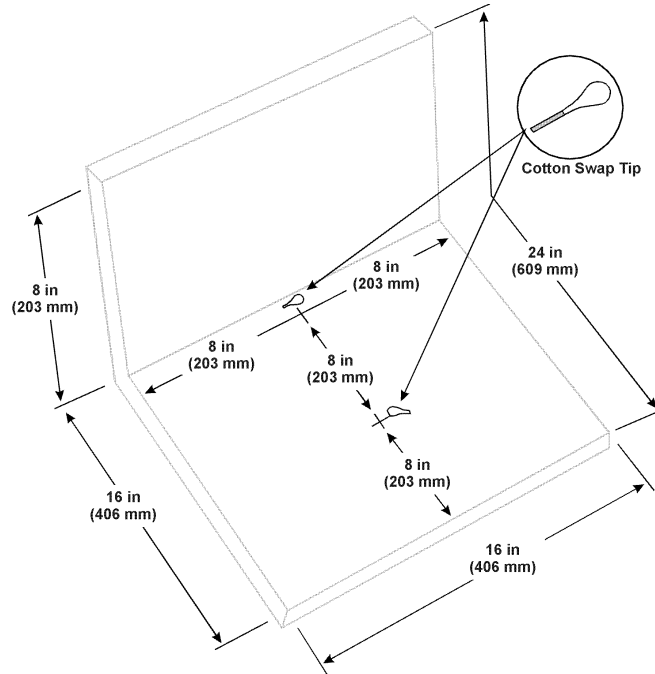

Figure 22-1. Cotton Swab Test Configuration

- 22.5.2 Remove the wooden sticks from the cotton swabs.
- 22.5.3 Dip the cotton-tipped ends into the alcohol. Tweezers can be used to accomplish this.
- 22.5.4 Ignite the cotton-tipped ends and place one flaming tip in the center of the blanket and one in the crease.
- 22.5.5 Allow the cotton-tipped ends to burn to completion or until they self-extinguish.
- 22.5.6 Measure the longest burn lengths extending from the center cotton tip and the crease cotton tip.

22.6 Report

- 22.6.1 Identify and describe the test specimen.
- 22.6.2 Report each burn length.
- 22.6.3 Report any flame spread, if applicable.

22.7 Requirements

- 22.7.1 No burn length shall exceed 8 inches (203.2 mm).

Appendix A FAA Regulations

A.1 A Brief History of Federal Agencies Regulating Aviation

The Federal Aviation Administration (FAA) has had its present name and place in the Federal establishment since April 1, 1967, the day the Department of Transportation (DOT) began operations. It has existed, however, in recognizably similar forms since 1926 when Congress enacted the Air Commerce Act, establishing an Aeronautics Branch within the Department of Commerce. Passed at the request of the aviation industry, which believed the airplane could not reach its full commercial potential without Federal safety regulation, the act charged the Secretary of Commerce with fostering air commerce, issuing and enforcing air traffic rules, licensing pilots, certifying aircraft, establishing airways, and operating and maintaining aids to air navigation.

Over the next decade, the Department of Commerce fulfilled its civil aviation responsibilities by concentrating on airway development, safety rulemaking, and pilot and aircraft certification. In 1936 a major shift occurred: Commerce assumed responsibility for controlling enroute air traffic. Air traffic control (ATC) eventually became, in terms of manpower and facilities employed, the Federal Government's most demanding civil aviation responsibility.

In 1938, with the enactment of the Civil Aeronautics Act, the Federal civil aviation role passed from Commerce to a new independent agency, the Civil Aeronautics Authority. That legislation expanded the Federal civil aviation role by giving the Authority the power to issue air carrier route certificates and regulate airline fares. In 1940, President Franklin Roosevelt split the Authority into two agencies, the Civil Aeronautics Board (CAB) and the Civil Aeronautics Administration (CAA). The CAA, lodged in the Department of Commerce, was responsible for ATC, airman and aircraft certification, safety enforcement, and airways development. In 1946, Congress added to these responsibilities a Federal aid airport program.

The Federal Aviation Act of 1958, whose passage had been spurred by a series of midair collisions, transferred the CAA's functions to a new independent body, the Federal Aviation Agency. This act was significant in two other respects. It took safety rulemaking from the CAB and entrusted it to the Federal Aviation Agency. More importantly, it gave the Federal Aviation Agency the sole responsibility for developing and maintaining a common civil-military system of air navigation and ATC, a responsibility that the CAA had shared with others.

In 1967, the Federal Aviation Agency was renamed the Federal Aviation Administration and placed in the newly created DOT. The creation of the DOT reflected a growing awareness in Congress, the executive branch, and the transportation industry that integrated and balanced transportation systems were required to meet the nation's transportation needs and that such systems could best be achieved by a single department.

Meanwhile, the FAA was assuming responsibilities not originally contemplated by the Federal Aviation Act. In 1968, Congress vested in the FAA Administrator the power to prescribe aircraft noise standards. The hijacking epidemic of the 1960s also involved the agency in a new area, aviation security. Finally, in 1970, the Airport and Airway Development Act authorized the FAA Administrator to establish minimum safety standards for airports and issue operating certificates to air carrier airports meeting those standards.

In the 1970s, the FAA and other Federal employees joined the ranks of organized labor. The Federal union movement began in 1962 when President John F. Kennedy granted by executive order the right of Federal employees to join unions and engage in collective bargaining. In 1968, a group of New York-based controllers formed the Professional Air Traffic Controllers Organization (PATCO), a professional society that eventually became a labor union. FAA-PATCO relations fell into three distinct periods: the early, strife-marked period that culminated in a 1970 "sickout" in which 3,000 controllers participated; a period of relative labor peace that saw controllers gain valuable wage and retirement benefits; and another period of strife, beginning in 1980, that led to 12,300 PATCO members going on strike in August 1981, the firing of the strikers, and the decertification of PATCO. Despite the loss of most of its controller workforce, the FAA kept the airways open and brought the ATC system close to its 1981 capacity within 2 years.

Airspace system capacity, however, was a long-term problem. Congress had created the FAA to meet the airspace challenges of the jet age. A large part of the FAA's response was the third-generation ATC system, a semiautomated radar- and computer-based system. That system was capitalized by user taxes from a trust fund created by the Airport and Airway Revenue Act of 1970. Despite the steady infusion of trust fund capital, the third-generation ATC system showed signs of wear by the early 1980s. Air traffic had surged dramatically, testing the limits of the system's capacity.

Traffic growth had been fed in part by the competitive environment created by the Airline Deregulation Act of 1978, which introduced fare and route competition in the air passenger industry and permitted unrestricted entry by new domestic carriers. Accordingly, in December 1981, the FAA unveiled the National Airspace System Plan, a blueprint for a state-of-the-art traffic control and air navigation system to accommodate projected growth in air travel over the next 20 years.

A.2 Organization of the FAA

The FAA is currently part of the DOT and is under the leadership of an Administrator who reports to the Secretary of Transportation.

The organizational structure of the FAA has undergone numerous changes over the years. Regardless of changes at the top levels of FAA headquarters and field offices, the "firing line" levels at or near the bottom, where the ultimate action takes place, have usually been relatively unaffected. Future reorganizations most likely will have little, if any, effect on day-to-day work functions of the local FAA offices. This familiarization with the FAA organization will, therefore, be based upon that assumption.

A.2.1 Headquarters

The top levels at FAA headquarters for design certification, production certification, and airworthiness certification begin with the Executive Director of Regulatory Standards and Compliance, under whom is the Associate Administrator for Regulation and Certification. Among the offices under the Associate Administrator is the Aircraft Certification Service, which has the responsibility for overseeing the Aircraft Certification Directorates, and the Washington Headquarters operations related to design, production, and airworthiness certification. The Aircraft Manufacturing Division of the Aircraft Certification Service has total responsibility for national policy and regulations governing production of aircraft and replacement parts (quality assurance) and the requirements for issuance of airworthiness certificates and export approvals. The engineering functions for aircraft and engine design certification policy and regulations are divided among four field offices, called Directorates. The Aircraft Engineering Division of the Aircraft Certification Service is responsible for national policy that affects all four of the Directorates and for policy and regulations for unique aircraft not otherwise covered by an aircraft category.

A.2.2 Directorates/Aircraft Certification Division

The headquarters of the Aircraft Certification Directorates/Divisions (ACDs) and the categories for which they are responsible are as follows:

- a. For transport category airplanes (Federal Aviation Regulation [FAR] Part 25), the Directorate headquarters is in Seattle, Washington.
- b. For small airplanes (FAR Part 23), the Directorate headquarters is in Kansas City, Missouri.
- c. For rotorcraft of all categories (FAR Parts 27 and 29), the Directorate headquarters is in Fort Worth, Texas.
- d. For engines and propellers (FAR Part 33 and 35), the Directorate headquarters is in Boston, Massachusetts.

The ACD is also responsible for implementing certification programs (type, production, and airworthiness) within the geographic boundaries of the Directorate, subject to the policy guidance of the ACD in the Directorate responsible for the product involved. For example, the transport category Directorate is responsible for accomplish-

ing all of the work required for type certification of an engine whose manufacture is located in Seattle, but the engine/propeller Directorate headquartered in Boston is responsible for policy guidance and regulatory interpretations, if required.

Each Directorate/Division is responsible for development, coordination, and issuance of documents related to the assigned category, including

- a. Airworthiness Directives (ADs)
- b. Regulatory Changes
- c. New Regulations
- d. Advisory Circulars (ACs)
- e. FAA Internal Directives (Orders, Notices, etc.)

NOTE: The authority outlined above does not include changes to procedural regulations, such as FAR Part 21, that would affect all Directorates. Such changes are the responsibility of the Engineering Division in FAA Washington Headquarters.

A.2.3 Directorates/Aircraft Certification Offices

The day-to-day work functions within the geographic area for which each Directorate is responsible are carried out by Aircraft Certification Offices (ACOs), whose managers report to the Directorate Aircraft Certification Division. ACOs consist of branches and sections covering the various engineering specialities related to design certification of aircraft, aircraft engines, propellers, and replacement parts for those products. ACO design certification programs encompass all categories of products whose manufacturers are located within the ACO geographic area of responsibility. Policy guidance for ACO design approval projects is provided by the Inspection Branch responsible for monitoring the manufacturing (quality assurance) and airworthiness certification programs with policy guidance from the Manufacturing Division at FAA headquarters.

A.2.4 Directorates/Manufacturing Inspection District Offices

The managers of the Manufacturing Inspection District Offices (MIDOs) report to the manager of the ACO, except for technical policy guidance when reporting may be to the Aircraft Certification Division at the option of the ACO manager. The MIDO's primary functions are not related to any specific product category, as in engineering, since such functions are generally similar regardless of the type of product involved. The MIDO responsibilities include

- a. Evaluation of production quality assurance systems for compliance with the FAR, leading to issuance of production approvals.
- b. Surveillance of approved production facilities.
- c. Providing support to FAA engineering in design approval programs through conformity inspections of prototype/first article products and witnessing tests as requested by engineering.
- d. Issuance of airworthiness certificates for new aircraft.
- e. Issuance of export approvals for new aircraft, aircraft engines, propellers, or their major components.
- f. Enforcement of the FAR applicable to production approvals.

The MIDO manager may assign Principal Inspectors (PIs) for major production approval holders. The PI is responsible for oversight of his or her assigned manufacturer, and for ensuring the timely accomplishment of the MIDO functions that apply.

A.2.5 The FAA William J. Hughes Technical Center

The FAA William J. Hughes Technical Center is located at the Atlantic City International Airport in New Jersey. It serves as the national test center for FAA research and development programs in air traffic control, communications, navigation, airports, and aircraft safety. Work involves the long-range development of new systems and concepts, development of new equipment and techniques to be placed in service in the near future, and in-service modifications to existing systems and procedures.

Most of the ongoing technical projects are assigned by FAA headquarters. Some testing takes place at other locations where the environment is more suitable, and some work is contracted to private industry and universities.

Center test pilots operate a fleet of specially instrumented aircraft that range in size from small airplanes to helicopters and large transports.

Major test facilities include

- Air Traffic Simulation Facility
- Air Traffic Laboratories
- Radar Test Laboratories
- Navigation Facilities
- Tracking Range
- Aircraft Safety Area

The Aircraft Safety Area contains special facilities for fire and accident tests on aircraft, components, and engines. They include a catapult, wind tunnel, chemistry laboratory, engine test cells, and a full-scale fire test facility, the largest of its kind in the world.

A.2.6 Civil Aeromedical Institute

The Civil Aeromedical Institute (CAMI) is located at the Mike Monroney Aeronautical Center at the Oklahoma City Airport in Oklahoma. It conducts medical research projects applicable to the mission of the FAA. The CAMI develops, maintains, and manages a system for the medical examination and certification of U.S. civil airmen and develops, maintains, and administers aviation medical education programs to meet the needs of the FAA. It also participates in the investigation of aircraft accidents regarding survivability factors and biomedical and psychological causes of accidents, such as disease and substance abuse.

A.3 Enabling Legislation and Procedures for the FAA

The top level public law that governs the activities of the FAA is the Federal Aviation Act of 1958, as amended. All FAA operating procedures must be in accordance with the Federal Aviation Act. The Act may be amended by Congress, however, if a compelling need for such an amendment exists.

Most of the FAA operations are covered under Title VI, "Safety Regulation of Civil Aeronautics." Section 601 of this Title gives the FAA Administrator the power and duty to prescribe and revise minimum standards and rules and regulations governing, among other things, "the design, material, workmanship, construction, and performance of aircraft, aircraft engines, and propellers as may be required in the interest of safety." Therein lies the basis for the FARs.

A.3.1 Federal Aviation Regulations

FARs are issued by the FAA to implement the provisions of the Federal Aviation Act, which gives only the basic objectives with little detail. Compliance with the FARs is mandatory to obtain the kind of certificates or approvals to which the particular FAR applies. Once a certificate or approval is issued for a purpose that requires ongoing compliance, such as a Production Certificate, noncompliance with or violation of the terms of, the approval would

result in civil penalty or administrative enforcement action, or if the infraction is of a serious nature, the certificate or approval could be suspended or revoked.

A.3.1.1 Petitions for Rulemaking

The procedures to be followed in presenting Petitions for Rulemaking are detailed in FAR Part 11. The basic requirements that must be met in a petition are that the petition must explain the interests of the petitioner in the action sought, and contain information, views, or arguments as to why granting the request would be in the public interest.

If the FAA determines that the basic requirements for a petition have been met, a summary of the petition is published in the Federal Register and public comments are invited. To be considered, comments must be submitted to the FAA within a time period specified in the published summary (usually 60 days). If the FAA finds that the petition is not acceptable after considering the public comments, it is returned to the petitioner, who may then resubmit the petition with additional information. If, however, the FAA determines, after consideration of its own analysis of the petition and of all public comments received in response to the summary, that the petition has merit, the FAA institutes rulemaking procedures.

A.3.1.1.2 Notices of Proposed Rulemaking

When the FAA initiates rulemaking, a part of the rulemaking action is publication of the proposed new or amended regulation in the Federal Register as a Notice of Proposed Rulemaking (NPRM), with public comments invited. To be considered, comments must be submitted to the FAA within a time period specified in the published NPRM. Each comment received must be analyzed by the FAA and may be either accepted or rejected, depending on whether the commenter has provided justification and substantiation of his/her views. Comments that state simply “for” or “against” without support information are generally not given consideration. The substance of comments that are accepted would be incorporated into the proposed regulation.

After all actions related to the NPRM and comments received are completed, and the proposed rule has completed the interagency coordination process, the final rule may be approved by the FAA Administrator or his or her designee.

Because of the extensive coordination required for rulemaking actions, including the DOT and the Office of Management and Budget, the time elapsed between initiation of the action and adoption of the final rule may be a year or more, depending on whether the proposed rule is imposing or relieving a burden to the public and whether the proposal is controversial in nature. The only exception to the long time element is in the case of ADs, which may be processed quickly under emergency procedures.

A.3.1.2 Exemptions from FARS

Anyone may petition the FAA for an exemption from a regulation following procedures set forth in FAR Part 11, which are similar to those for petition for rulemaking. The primary difference between a petition for exemption and a petition for rulemaking is that the petitioner for an exemption must include reasons why safety would not be adversely affected if the exemption is granted or must explain the action to be taken by the petitioner to provide a level of safety equal to that provided by the rule from which the exemption is sought.

The processing of a petition for exemption is also similar to that for a petition for rulemaking, except that full interagency coordination is generally not necessary or accomplished more quickly. The final action on a petition for exemption may usually be determined within 60 to 90 days or, if the petitioner shows good cause, sooner.

The final action on a petition for an exemption may be either a grant if the petitioner has shown good cause or a denial if he/she has not. In the case of a denial, the petition may be resubmitted if the petitioner has new information that would provide better substantiation.

The scope of exemptions varies considerably—an exemption may be valid only for one person on a short-term basis or may apply to an organization or a group and be effective for several years. Exemptions are not normally granted on a permanent basis, but in cases where the need is ongoing for many years, the original petitioner may request renewal when the exemption expires, provided the need for the renewal is adequately substantiated.

An exception to the usual requirement that exemptions expire on a given date unless renewed is the case of an exemption granted from a regulation in the airworthiness standards of FAR Parts 23 and 25. Such exemptions may be permanent, and since they constitute a deviation from published airworthiness standards, they must be listed on the Standard Airworthiness Certificates issued for the aircraft affected by the exemption to satisfy the requirements of the International Civil Aviation Organization (ICAO).

A.3.2 Airworthiness Directives (ADs)

ADs are issued by the FAA when an unsafe condition exists in a product, and that condition is likely to exist in other products of the same type design. The need for an AD may be identified as a result of an accident, maintenance problems, routine inspections, etc. The primary criteria upon which the FAA bases decisions for AD action are that an unsafe condition was found and that the same condition is likely to exist in other aircraft.

The corrective action prescribed by the AD, such as an inspection, a repair, or a modification, may be detailed in the AD itself or may be contained in another document, such as a manufacturer's Service Bulletin, which is referenced in the AD.

ADs have the same authority as a FAR and, as such, compliance with ADs is mandatory. Noncompliance with an AD that, for example, applies to an aircraft would be in violation of the terms of issuance of the airworthiness certificate, resulting in its invalidation—in effect, grounding the aircraft. The same effect would result if an engine, propeller, or appliance with an unincorporated AD was installed on an aircraft.

The procedures for processing ADs generally follow those previously discussed under the development of FARs, beginning with publication of the draft AD in the Federal Register as an NPRM, with public comments invited, except when the situation requires urgent action to preserve safety, an emergency AD may be issued immediately without the full rulemaking process.

The FAA Directorate for the product involved, usually in conjunction with the local ACO, is responsible for drafting the AD and coordinating the rulemaking process. The text of the AD and the corrective action is usually a joint effort between the manufacturer and FAA engineering. Input and comments are also considered from other segments of the FAA and from individuals or organizations representing aircraft operators.

A.3.3 Technical Standard Orders

Under the Civil Aeronautics Act of 1938, the Administrator of Civil Aeronautics was authorized to adopt the Technical Standard Order (TSO) system to establish minimum performance standards and specifications of aircraft materials, parts, processes, and appliances that are used on civil aircraft.

TSOs are covered in FAR Part 21, "Certification Procedures for Products and Parts," as Subpart O, "Technical Standard Order Authorizations." The TSO requirements cover most, but not necessarily all, of the requirements on that item in the FARs.

A TSO Authorization is an FAA design and production approval issued to the manufacturer of an article that has been found to meet a specific TSO.

A Letter of TSO Design Approval is an FAA design approval for a foreign-manufactured article, which has been found to meet a specific TSO in accordance with specified procedures.

A.3.4 Congressional Actions

In a number of cases involving controversial issues, Congress passed amendments to the Act that mandates FAA action, even though the Act may already provide for such action. Notable examples of this are all sections in Title VI, amended to require Emergency Locator Transmitters in certain aircraft, to establish Noise Abatement requirements, and most recently, to establish requirements for Mode C transponders in aircraft operating in controlled airspace.

A.3.5 Directives that Implement FARs

Directives that implement FARs are issued to provide guidance or an acceptable means of compliance with specific FARs. Such directives are not normally mandatory on an applicant for an FAA certificate or approval. If compliance with their provisions would result in a burden on, or adversely affect a segment of the aviation community, a draft must be published in the Federal Register for public review and comment, which must be considered before the directive can be issued. This requirement applies to all directives issued by any U.S. Government agency, including those whose purpose is to govern internal operations but, in so doing, may have an adverse effect on the public.

A.3.5.1 Advisory Circulars (ACs)

The FAA issues ACs to inform the aviation public in a systematic way of nonregulatory material of interest. Unless incorporated into a regulation by reference, the contents of an AC are not binding on the public. Among other things, ACs are used to show a method acceptable to the FAA, but which may not be the only method, for complying with a related FAR.

ACs are available to the public through several means. Some are free, depending on content and number of pages, and may be obtained from the DOT, Washington, D.C., or from Government Printing Office bookstores located in many major cities. Anyone may also ask to see ACs at any ACD, ACO, or MIDO.

ACs are developed by the FAA office having primary responsibility for the subject of the AC. For example, ACs concerning FAR Part 25 Airworthiness Standards for transport category aircraft are developed by the Transport Airplane Directorate. ACs that are to provide information or guidance concerning FAR Part 21, which applies to all Directorates, would most likely be developed by FAA headquarters.

The approval process for ACs varies, depending on the subject matter. An AC that only provides information of interest to the public, or a service or guidance of a helpful nature, may be coordinated within the FAA and issued without publication in the Federal Register. On the other hand, an AC that announces policy on a controversial subject, or provides an acceptable means of compliance with a FAR, would normally be published in the Federal Register for public comment before the AC is issued.

A.3.5.2 Internal Directives

Internal directives govern the internal operations of the FAA and generally are for use by FAA personnel only. Some provide guidance and instructions to field office personnel for functions that may affect the public, in which case someone affected by the directive may ask to see it or may obtain a copy. Under normal conditions, however, guidance that impacts the public is issued as an AC. Some internal directives may contain classified information that is not available to the public.

A.3.5.2.1 Orders

Orders are the highest level of internal directives, covering a wide range of subjects from establishing the functions and responsibilities of all FAA offices—both headquarters and field—to providing permanent guidance and instruction to field offices and FAA personnel. Orders are normally developed and coordinated within the FAA and are not released for public comment prior to publication.

Orders that do not contain classified information may be made available to the public, particularly those governing the activities of the field offices.

Orders may be single page documents or complete texts of instruction material, issued as “handbooks.” Examples of FAA Orders are the Designated Engineering Representative (DER) Handbook (Order 8110.37) and the Type Certification Handbook (Order 8110.4). The Order number is in accordance with the FAA subject classification system—8110 is Engineering—and all forms of reports related to the subject also have the same number, e.g., the DER Certificate of Authority, FAA Form 8110-25, and the Statement of Compliance, FAA Form 8110-3.

A.3.5.2.2 Notices

Notices have the same authority within the FAA as Orders; however, Notices are temporary, usually expiring in less than 1 year. The processing of a Notice may generally be completed more quickly than an Order, but if the material in the Notice is to be effective for more than 1 year, it must be reprocessed as an Order prior to the expiration of the Notice.

Notices may be used to transmit other official data, provide information or guidance intended for “one-time-only” use, or provide instructions of an “emergency” nature to field offices. Such “emergency” Notices may be issued as telegrams called GENOTs (General Notices).

A.3.5.2.3 Memorandums

Memorandums are sometimes used to provide guidance or interpretations when the “audience” is very limited—such as to one field office. Memorandums are also issued by the FAA General Counsel to provide legal interpretations of FARs in controversial cases and are official policy documents. Regardless of the purpose of Memorandums, if the information concerns FAA policy that should be distributed agency-wide, the Memorandum is eventually issued as an AC, Order, or incorporated into existing ACs or internal directives.

A.4 Documentary Sources for Flammability Requirements

Documentation specifying flammability requirements and test procedures fall primarily in Civil Air Regulation (CAR) Parts, FAR Parts, TSOs, and ACs.

A.4.1 Civil Air Regulations Parts

CARs that relate to certification flammability requirements and fire testing are—

CAR Part 3	Airplane Airworthiness; Normal Utility and Acrobatic Airplanes
CAR Part 4b	Airplane Airworthiness; Transport Category
CAR Part 6	Rotorcraft Airworthiness; Normal Category
CAR Part 7	Rotorcraft Airworthiness; Transport Category

These CAR Parts will still be addressed because the current fleet contains models that were certified to CARs (e.g., the Boeing 707 and 727-100, the Douglas DC- series through the DC-9, and the Lockheed Electra).

Approved test methods to be used in demonstrating compliance with these CAR requirements were published in Safety Regulation Release (SRR) No. 259 in 1947. Flight Standards Service Release (FSSR) No. 453 superseded SRR No. 259 in 1961, pending incorporation of appropriate test procedures in Civil Aeronautics Manuals.

The SRR and FSSR contained a fireproof test, two different types of fire-resistant tests, and flame-resistant and flash-resistant tests, both of which involved a Bunsen burner and a horizontal test specimen.

Although the FSSR was canceled by AC 00-20 on September 7, 1966, it was never completely replaced by an AC. It is still used for CAR certified airplanes.

A.4.2 FAR Parts

The CARs were reorganized and reissued without additional requirements as FARs in 1965, when the Civil Aeronautics Agency was made a part of the DOT as the FAA. FARs that relate to certification flammability requirements and fire testing are:

FAR Part 1	Definitions
FAR Part 21	Certification Procedures for Products and Parts
FAR Part 23	Airworthiness Standards: Normal Utility and Acrobatic Category Airplanes
FAR Part 25	Airworthiness Standards: Transport Category Airplanes
FAR Part 27	Airworthiness Standards: Normal Category Rotorcraft
FAR Part 29	Airworthiness Standards: Transport Category Rotorcraft
FAR Part 33	Airworthiness Standards: Aircraft Engines
FAR Part 37	Technical Standard Order Authorizations
FAR Part 91	General Operating and Flight Rules
FAR Part 121	Certification and Operations: Domestic, Flag, and Su

Appendix B The Approval Process

B.1 Introduction

In the Federal Aviation Act of 1958, a complex multistep approval/certification process was established for the FAA to follow to ensure that civil aircraft meet minimum safety requirements. These regulations are found in 14 Code of Federal Regulations (CFR), which comprise the Federal Aviation Regulations (FARs). 14 CFR Parts are commonly referred to as FAR Parts.

The regulatory requirements that civil aircraft must meet depend on the type of aircraft involved (i.e., light airplanes, large multipassenger airplanes, helicopters, etc.) and the aircraft's intended use (i.e., private, crop dusting, airline, external load-bearing helicopters, etc.). A detailed description of the approval steps and procedures is beyond the scope and needs of this Handbook. However, a general description is given with appropriate details relevant to approval steps and procedures requiring flammability testing.

The basic premise of the regulations is that each aircraft must be approved. Except for "public aircraft" (i.e., those operated by the federal, state, or local government), all civil aircraft must be approved by the FAA before they can be placed into any service. To acquire the necessary approvals, it must have been demonstrated to the FAA via the multistep approval process that the aircraft complies with appropriate regulatory requirements.

The FAA is not setup nor intended to have responsibility for carrying out the various steps in the approval process. The FAA's function is essentially to review and approve designs, test and production hardware, test plans, and to witness tests and approve test data. The primary responsibility for carrying out the necessary demonstrations of compliance lies with aircraft manufacturers and operators. Manufacturers perform some of the approval steps and aircraft operators perform the others.

B.2 Approval Steps Manufacturers

The manufacturer of each aircraft produced must receive FAA approval for that aircraft before it can be operated by its owner/operator. The regulatory requirements are covered in the FAR Parts dealing with Airworthiness Standards. The procedures are defined in FAR Part 21, Certification Procedures for Products and Parts.

Manufacturers are responsible for carrying out and receiving FAA approval of the several steps involved with the design and manufacture of aircraft.

B.2.1 Certification Requirements

Airworthiness Standards contain performance requirements for the certification of aircraft. The FAR Parts dealing with Airworthiness Standards are

FAR Part 23, Airworthiness Standards: Normal Utility and Acrobatic Category Airplanes
FAR Part 25, Airworthiness Standards: Transport Category Airplanes
FAR Part 27, Airworthiness Standards: Normal Category Rotorcraft
FAR Part 29, Airworthiness Standards: Transport Category Rotorcraft
FAR Part 33, Airworthiness Standards: Aircraft Engines
FAR Part 35, Airworthiness Standards: Propellers

Airworthiness Standards are amended from time to time to modify (upgrade, clarify, etc.) the requirements. The regulatory requirements that a specific aircraft must comply with are established by the amendment level of the applicable FAR Part that applies to that aircraft, plus any special conditions that may be levied by the FAA on that aircraft for its certification. These requirements are known as the "regulations incorporated by reference," which are identified on the aircraft's Type Certificate data sheet (see section B.2.2.1).

B.2.2 Certification Procedures

The basic item that the FAA approves is the aircraft. Aircraft parts are not “approved” in the same sense, since a review of aircraft components for compliance to a set of requirements is only done in conjunction with the approval of an aircraft. It is possible to have test data generated by testing a part “approved” (as by a Designated Engineering Representative [DER] using an 8110-3 form [see figure B-1]) but such “approval” alone does not approve the use of the part itself.

U.S. DEPARTMENT OF TRANSPORTATION FEDERAL AVIATION ADMINISTRATION			DATE
STATEMENT OF COMPLIANCE WITH THE FEDERAL AVIATION REGULATIONS			
AIRCRAFT OR AIRCRAFT COMPONENT IDENTIFICATION			
MAKE	MODEL NO.	TYPE (Airplane, Radio, Helicopter, etc.)	NAME OF APPLICANT
LIST OF DATA			
IDENTIFICATION	TITLE		
PURPOSE OF DATA			
APPLICABLE REQUIREMENTS (List specific sections)			
<p>CERTIFICATION - Under authority vested by direction of the Administrator and in accordance with conditions and limitations of appointment under Part 183 of the Federal Aviation Regulations, data listed above and on attached sheets numbered _____ have been examined in accordance with established procedures and found to comply with applicable requirements of the Federal Aviation Regulations.</p> <p>I (We) Therefore <input type="checkbox"/> Recommend approval of these data <input type="checkbox"/> Approve these data</p>			
SIGNATURE(S) OF DESIGNATED ENGINEERING REPRESENTATIVE(S)	DESIGNATION NUMBERS(S)	CLASSIFICATION(S)	

FAA Form 8110-3 (11-70) SUPERSEDES PREVIOUS EDITION

Figure B-1. FAA Form 8110-3 (Statement of Compliance)

FAR Part 21, Certification Procedures for Products and Parts, contains the procedures required for manufacturers to receive FAA approval of aircraft or aircraft parts.

The approval process for aircraft and aircraft parts involves three separate sequential steps, each of which requires FAA approval:

1. Approval of design of aircraft
2. Approval of quality control of production of aircraft
3. Approval of each aircraft produced

B.2.2.1 Certification of Design

Approval of the design of the aircraft is the first step in the total multistep approval process. This requires that the manufacturer demonstrate to the FAA that the design of the aircraft meets the relevant Airworthiness Standards.

It is important to recognize that FAA approval of the design of an aircraft does not by itself constitute approval of either the production of that aircraft nor the service use of manufactured duplicates of that aircraft. The FAA must approve production and service use of aircraft in separate steps.

FAA approval of a design is the responsibility of the Aircraft Certification Offices (ACOs). No other section of the FAA has the authority to issue design approval.

The ACOs do not have adequate manpower to carry out all the reviews and inspections necessary for design approval of aircraft. The ACOs have been authorized by statute to delegate certain inspection and certification responsibilities to DERs who are properly qualified private persons not employed by the FAA. DERs may be employees of manufacturers involved with aircraft (material suppliers, holders of Production Certificates, Technical Standard Order [TSO] Authorizations, Part Manufacturer Approvals [PMAs], etc.). In determining whether an aircraft complies with FAA regulations, DERs are guided by the same requirements, instructions, and procedures as ACO personnel.

Each DER authorization is typically limited to a specific technical area that reflects that person's expertise, DERs who are employees of manufacturers are, in addition, typically only authorized to approve designs involving that manufacturer's products. Design approvals by a DER that are outside his or her normal authorization may only be authorized by the cognizant ACO on a case-by-case basis.

B.2.2.1.1 Type Certificates

A Type Certificate (see figure B-2) is issued to an aircraft model that meets all the applicable Airworthiness Standards and special conditions for that model. The model's Type Design refers to all its individual parts and systems. The Type Design consists of the drawings and specifications necessary to define the configuration and the design features of the aircraft model that are needed to show compliance with applicable Airworthiness Standards and special conditions.

FAA approval of the Type Design requires that the applicant carry out all the tests necessary on conformed prototype individual parts (see section B.2.1.4.1) and systems, as well as flight tests on a confirmed prototype of the aircraft itself.

After the FAA has approved the Type Design, it issues a Type Certificate (TC) for the design of the aircraft model.

B.2.2.1.2 Amended Type Certificates

If a holder of the Type Certificate covering an aircraft model wishes to make a major change in the Type Design (not great enough to require a new Type Certificate) of the aircraft, an Amended Type Certificate covering the revised Type Design is required.

The United States of America
Department of Transportation
Federal Aviation Administration

Type Certificate

Number A20WE

This certificate issued to **THE BOEING COMPANY**
certifies that the type design for the following product with the operating limita-
tions and conditions therefor as specified in the Federal Aviation Regulations and the
Type Certificate Data Sheet, meets the airworthiness requirements of Part 25 of
the Federal Aviation Regulations. (See Page 2 for Aircraft Noise Requirements.)

Model 747-100 Series

This certificate, and the Type Certificate Data Sheet which is a part hereof,
shall remain in effect until surrendered, suspended, revoked, or a termination date is
otherwise established by the Administrator of the Federal Aviation Administration.
This certificate consists of two pages.

Date of application: 22 April 1966 .

Date of issuance: 30 December 1969

By direction of the Administrator:

(Signature) Robert H. Stanton

(Title) Chief, Aircraft Engineering Division

This certificate may be transferred if endorsed as provided on the reverse hereof.

Any alteration of this certificate and/or the Type Certificate Data Sheet is punishable by a fine of not exceeding \$1,000,
or imprisonment not exceeding 3 years, or both.

FAA FORM 8110-9 (7-67) SUPERSEDES FAA FORM 331

Figure B-2. Federal Aviation Administration Type Certificate

The applicant for an Amended Type Certificate must show that the aircraft continues to comply with the regulations incorporated by reference plus any additional requirements such as amendments to the Airworthiness Standards and/or special conditions that were not included in the original Type Design.

The procedure for obtaining an Amended Type Certificate is basically the same as for obtaining Type Certificates.

B.2.2.1.3 Supplemental Type Certificates

If a party wishes to make a major change in the Type Design of an aircraft model (not great enough to require a new Type Certificate), and the party is not the holder of the Type Certificate for that aircraft model, approval of the change requires a Supplemental Type Certificate (STC). A holder of a Type Certificate who wishes to make a change in the Type Design that is less than that involving the derivative aircraft may also apply for a STC.

STCs, in practice, are used for specific design features of the aircraft and do not, as a rule, involve modifications to other, unaffected design features of the aircraft.

B.2.2.1.4 Individual Aircraft Parts

Individual aircraft parts are not “approved” by the FAA; only the aircraft on which the part is used is approved.

To obtain approval for the use of a part on an aircraft, the applicant must comply with the Type Design of the aircraft on which they are to be installed. The applicant must apply to an FAA ACO for approval of the design of the part. The application must include a complete formal description (e.g., drawing or drawings) of the design and the aircraft on which the part is to be installed. The design must be sufficiently definitive and unambiguous to define the item and the requirements that it must satisfy.

B.2.2.1.4.1 Conformity Inspection

If testing of the part is required, the applicant must provide a fabricated prototype of the part along with an FAA 8130-9 form, Statement of Conformity (see figure B-3), stating that the prototype conforms with the design (i.e., was fabricated using the materials and processes prescribed in the formal description of the design). An FAA Manufacturing Inspector or his or her designee must then examine the prototype (and any required accompanying evidence) to determine whether or not the demonstration of its conformity is satisfactory. If satisfactory, the Manufacturing Inspector (or his or her designee) will effect an FAA 8130-3 form, Conformity Certification (see figure B-4), stating that the prototype is in conformity.

B.2.2.1.4.2 Test Plan Preparation

Any required tests must be performed on a prototype of the part to demonstrate that it complies with applicable regulations. The applicant must prepare a test plan that includes the following information:

- a. title, list of active pages, and revision record;
- b. the exact part usage, including aircraft model, and FAR flammability requirements, including the amendment level;
- c. the test procedure and the FAA-approved test facility to be used (the test date shall be coordinated with the FAA ACO or its designee for test witnessing);
- d. detailed and complete identification of material(s) used for part construction (a copy of the conformity inspection approval may be included; see section B.2.2.1.4.1); and
- e. an isometric sketch of the part with all individual test constructions/panels numerically identified, if the part to be certified requires that more than one construction be tested, such as a galley.

In order to facilitate completing a test report (see section B.2.2.1.4.3) upon completion of testing, data sheets for each test and each construction may be provided. The data sheet must be completely filled out with the exception of the test results. When the test results are entered and signed by the FAA witness or FAA designee (DER), the test plan may be used as the test report.

Not Subject to OMB Clearance

UNITED STATES OF AMERICA DEPARTMENT OF TRANSPORTATION FEDERAL AVIATION ADMINISTRATION STATEMENT OF CONFORMITY			
SECTION I - AIRCRAFT			
1. MAKE		2. MODEL	
3. SERIAL NO.		4. REGISTRATION NO.	
SECTION II - ENGINE			
1. MAKE		2. MODEL	
3. SERIAL NO.			
SECTION III - PROPELLER			
1. MAKE		2. HUB MODEL	
3. BLADE MODEL		4. HUB SERIAL NO.	
5. BLADE SERIAL NOS.			
SECTION IV - CERTIFICATION			
I hereby certify that: <ul style="list-style-type: none"> <input type="checkbox"/> A. I have complied with Section 21.33(a). <input type="checkbox"/> B. The aircraft described above, produced under type certificate only (FAR 21 Subpart F), conforms to its type certificate, is in a condition for safe operation, and was flight checked on _____ (Date). <input type="checkbox"/> C. The engine or propeller described above, presented herewith for type certification, conforms to the type design therefor. <input type="checkbox"/> D. The engine or propeller described above produced under type certificate only (FAR 21 Subpart F), conforms to its type certificate and is in a condition for safe operation. The engine or, if applicable, the variable pitch propeller was subjected by the manufacturer to a final operational check on _____ (Date). 			
Deviations:			
SIGNATURE OF CERTIFIER		TITLE	
ORGANIZATION		DATE	

FAA Form 8130-9 (9-78) USE PREVIOUS EDITION

Figure B-3. Statement of Conformity

1. Country UNITED STATES	2. <input type="checkbox"/> Conformity <input type="checkbox"/> Airworthiness	AUTHORIZED RELEASE CERTIFICATE APPROVAL TAG				3. Certificate Ref No.
4. Organization		5. Work Order/Contract/Invoice				
6. Item	7. Description	8. Part No.	9. Eligibility*	10. Qty.	11. Serial/Batch No.	12. Status/Work
13. Remarks						
14. New Parts: Certifies that the part(s) identified above except as otherwise specified in block 13 was (were) manufactured/inspected in accordance with the airworthiness regulations of the stated country and/or in the case of parts to be exported with the approved design data and with the notified special requirements of the importing country.		15. Used Parts: Certifies that the work specified above except as otherwise specified in block 13 was carried out in accordance with the airworthiness regulations of the stated country and the notified special requirements of the importing country and in respect to that work, the part(s) is (are) in condition for safe operation and considered ready for release to service. (over)				
16. Signature		17. Name (typed or printed)			18. Date	
19. Issued by or on behalf of the Federal Aviation Administration.						

* Cross-check eligibility for more details with parts catalog

FAA Form 8130-3 (9-88)

Figure B-4. Authorized Release Certificate Approval Tag

B.2.2.1.4.3 Test Report

If the results of the test show the prototype to be in compliance, a test report identifying the part and presenting the data must be prepared. If the test plan is completed in accordance with B.2.2.1.4.2, the test plan may be modified to become a test report by completing the test data sections on the data sheets provided. The ACO will then approve the part (usually as part of a Type Certificate or an STC activity), or its DER designee will effect an FAA 8110-3 form, Statement of Compliance with the Federal Aviation Regulations (see figure B-1), which indicates approval that the design of the item satisfies the specific requirement(s) of the regulations that the test covered. The ACO itself does not issue a 8110-3 form; only DERs do that.

B.2.2.1.5 Technical Standard Orders

A TSO is a minimum performance standard for specified articles (i.e., materials, parts, processes, or appliances) used on civil aircraft. The performance standards stated in the TSO reflect some (but not necessarily all) of the requirements for that article stated in the Airworthiness Standards.

A TSO authorization is an FAA acknowledgment that the design of the article meets the specified minimum performance standard in the TSO, and that the TSO holder may produce and mark the authorized article with the TSO designation.

It is important to recognize, however, that since amendments to Airworthiness Standards and to TSOs are made independently by the FAA, there may be situations when TSO requirements and Airworthiness Standards are not the same. In such a case, approval of the article may involve requirements beyond those of the TSO itself.

TSOs involving flammability include the following:

TSO C10a	Life Rafts (nonreversible)
TSO C13a	Life Preservers
TSO C13d	Life Preservers
TSO C17a	Fire-Resistant Aircraft Sheet and Structural Material
TSO C20	Combustion Heaters
TSO C22f	Safety Belts
TSO C25a	Aircraft Seats and Berths
TSO C30b	Aircraft Position Lights
TSO C31d	High-Frequency (HF) Radio Communications Transmitting Equipment
TSO C32d	High-Frequency (HF) Radio Communications Transmitting Equipment
TSO C34c	ILS Glide Slope Receiving Equipment
TSO C36e	ILS Localizer Receiving Equipment
TSO C37c	VHF Radio Communications Transmitting Equipment
TSO C38c	VHF Radio Communications Receiving Equipment
TSO C39b	Aircraft Seats and Berths
TSO C40c	VOR Radio Receiving Equipment
TSO C42	Propeller Feathering Hose Assemblies
TSO C51a	Aircraft Flight Recorder
TSO C53a	Fuel and Engine Oil System Hose Assemblies
TSO C57a	Aircraft Headsets and Speakers
TSO C58a	Aircraft Microphones
TSO C60b	Airborne LORAN-A and LORAN-C Receiving Equipment
TSO C63c	Airborne Weather and Ground Mapping Pulsed Radars
TSO C65a	Airborne Doppler Radar Ground Speed and/or Drift Angle Measuring Equipment
TSO C66b	Distance Measuring Equipment (DME)
TSO C68a	Airborne Automatic Dead Reckoning Computer Equipment
TSO C69b	Emergency Evacuation Slides, Ramps, and Slide/Raft Combinations
TSO C70a	Liferafts (Reversible and Nonreversible)
TSO C72c	Individual Flotation Devices

TSO C75	Hydraulic Hose Assemblies
TSO C77a	Gas Turbine Auxiliary Power Units
TSO C78	Crewmember Demand Oxygen Mask
TSO C85	Survivor Locator Lights
TSO C90b	Cargo Pallets, Nets, and Containers
TSO C94a	Omega Receiving Equipment
TSO C99	Protective Breathing Equipment

B.2.2.1.6 Parts Manufacturer Approval (PMA)

A PMA covers FAA approval for the production of certain materials, parts, processes, and appliances. A PMA application requires that the applicant submit for FAA approval the identity of the aircraft on which the part is to be installed, sufficient information defining the design of the part, and FAA approved test data showing that the design of the part complies with all Airworthiness Standards and special conditions applicable to the aircraft on which the part is to be installed.

B.2.2.2 Certification of Production Quality Control

FAA approval of production requires essentially the approval of the manufacturer's production quality control system. The mechanisms of approval vary depending on whether or not the manufacturer holds a Production Certificate, TSO authorization, or PMA. The details are not important for the purposes of this Handbook.

The purpose of the quality control system is to ensure consistent satisfactory production of all items involving FAA-approved designs.

In a quality control system, the manufacturer must provide for systematic monitoring of materials and processing to ensure that production goods meet their individual design requirements. The procedures used, including the frequency of inspections, must be documented and presented to the FAA for approval. Any changes in the quality control system must also be submitted to the FAA for approval.

FAA approval of a manufacturer's production quality control system is the responsibility of the Manufacturing Inspection Offices of the Manufacturing Inspection Branch. No other section of the FAA, including the Aircraft Certification Division, has the authority to approve a production quality control system.

The Manufacturing Inspection Offices, like the ACOs, do not have adequate manpower to carry out all the reviews and inspections necessary for approval and monitoring of production quality control systems. The Manufacturing Inspection Offices have been authorized by statute to delegate certain inspection and monitoring responsibilities to Designated Manufacturing Inspection Representatives (DMIRs) who are properly qualified private persons. DMIRs may be employees of manufacturers involved with aircraft (material suppliers, holders of Production Certificates, TSO authorizations, PMAs, etc.). In determining whether or not an aircraft or aircraft part complies with FAA regulations, DMIRs are guided by the same requirements, instructions, and procedures as Manufacturing Inspection Office personnel.

B.2.2.3 Certification of Individual Aircraft

Each individual aircraft must receive FAA approval before it can be placed into any service. If there are minor design differences between the actual produced aircraft and the Type Design used for the aircraft's Type Certificate, the ACO or its designee(s) must approve the design modifications.

The approval of the aircraft itself takes the form of an Airworthiness Certificate (FAA 8100-2 form), as shown in figure B-5, which signifies that the aircraft was manufactured according to the engineering drawings defining it and, therefore, complies with the applicable Airworthiness Standards and all special conditions that may apply to that aircraft.

UNITED STATES OF AMERICA DEPARTMENT OF TRANSPORTATION—FEDERAL AVIATION ADMINISTRATION			
STANDARD AIRWORTHINESS CERTIFICATE			
1 NATIONALITY AND REGISTRATION MARKS	2 MANUFACTURER AND MODEL	3 AIRCRAFT SERIAL NUMBER	4 CATEGORY
5 AUTHORITY AND BASIS FOR ISSUANCE This airworthiness certificate is issued pursuant to the Federal Aviation Act of 1958 and certifies that, as of the date of issuance, the aircraft to which issued has been inspected and found to conform to the type certificate therefor, to be in condition for safe operation, and has been shown to meet the requirements of the applicable comprehensive and detailed airworthiness code as provided by Annex 8 to the Convention on International Civil Aviation, except as noted herein. Exceptions:			
6 TERMS AND CONDITIONS Unless sooner surrendered, suspended, revoked, or a termination date is otherwise established by the Administrator, this airworthiness certificate is effective as long as the maintenance, preventative maintenance, and alterations are performed in accordance with Parts 21, 43, and 91 of the Federal Aviation Regulations, as appropriate, and the aircraft is registered in the United States.			
DATE OF ISSUANCE	FAA REPRESENTATIVE	DESIGNATION NUMBER	
Any alteration, reproduction, or misuse of this certificate may be punishable by a fine not exceeding \$1,000, or imprisonment not exceeding 3 years, or both. THIS CERTIFICATE MUST BE DISPLAYED IN THE AIRCRAFT IN ACCORDANCE WITH APPLICABLE FEDERAL AVIATION REGULATIONS.			
FAA Form 8100-2 (8-82)		GPO 570-189	

Figure B-5. Standard Airworthiness Certificate

FAA approval of an aircraft (i.e., the issuance of an Airworthiness Certificate to that aircraft) is the responsibility of the Manufacturing Inspection Offices of the Manufacturing Inspection Division. The approval may be delegated to a specific DMIR.

It is important to recognize that the production of each item used on an aircraft must generally be carried out within an FAA-approved quality control system; otherwise, an Airworthiness Certificate cannot be issued for that aircraft. For example, a transport category (FAR 25) airframe manufacturer who holds a Production Certificate may subcontract the fabrication of a part or purchase a part at the request of a customer for installation on that customer’s airplane or install a part supplied by a customer on that customer’s airplane. In such cases, the holder of the Production Certificate is responsible to the FAA for the conformity of the manufactured end item (i.e., for the quality control system used by whoever actually produces the item) unless the actual manufacturer of the item is otherwise covered by some FAA approval of production of that end item, such as a TSO or a PMA.

B.3 Approval Steps—Operators

Operators are responsible for carrying out and receiving FAA approval of the several steps involved with the maintenance and operation of the aircraft. These steps begin after the operator receives an aircraft from a manufacturer that has an Airworthiness Certificate.

The operators must obtain approvals under FARs covering Certification and Operations, viz.,

- FAA Part 91 General Operating and Flight Rules
- FAA Part 121 Certification and Operations: Domestic, Flag, and Supplemental Air Carriers, and Commercial Operators of Large Aircraft
- FAA Part 125 Certification and Operations: Airplanes Having a Seating Capacity of 20 or More Passengers or a Maximum Payload Capacity of 6,000 Pounds or More

FAR Part 127 Certification and Operations: Scheduled Air Carriers with Helicopters

FAR Part 129 Operations and Foreign Air Carriers

FAR Part 133 Rotocraft, External-Load Operations

FAR Part 135 Air Taxi Operations and Commercial Operators

The operation of airlines is covered in FAR Part 121 Certification and Operations: Domestic, Flag, and Supplemental Air Carriers, and Commercial Operators of Large Aircraft. The FAA sometimes amends FAR 121 to add requirements to airplanes operated by the airlines that are in addition to the Part 25 Airworthiness Standards that are applicable to those airplanes. The additional requirements sometimes force airlines to retrofit airplanes and/or to request from airplane manufacturers that newly manufactured airplanes meet the upgraded standards.

The Flight Standards Branch of the FAA is responsible for overseeing and approving the activities of aircraft operators. The activities are divided between those dealing with aircraft maintenance and those dealing with aircraft operations. For the purposes of this Handbook, only aircraft maintenance activities are relevant. The approval procedures essentially duplicate those in the Airworthiness Standards.

Appendix C Materials Used in Aircraft

C.1 Introduction

Materials used in aircraft are roughly the same regardless of the type of aircraft involved (normal and transport category airplanes and/or rotorcraft). The various Federal Aviation Regulations (FARs) refer mostly to FAR 25 for flammability requirements. For simplicity, this discussion will, therefore, refer only to FAR Part 25.

C.2 Aircraft Seats

Aircraft seats use a wide variety of nonmetallic materials in the constructions of the components that make up a complete seat. These components can be grouped into five basic areas (see figure C-1): foam cushions, upholsteries, fire blockers, plastic moldings, and structure. All nonmetallic seat parts must meet FAR 25.853(b). The cushions, which includes the foam, upholstery, and fire blocker (if used), must also meet FAR 25.853(c).

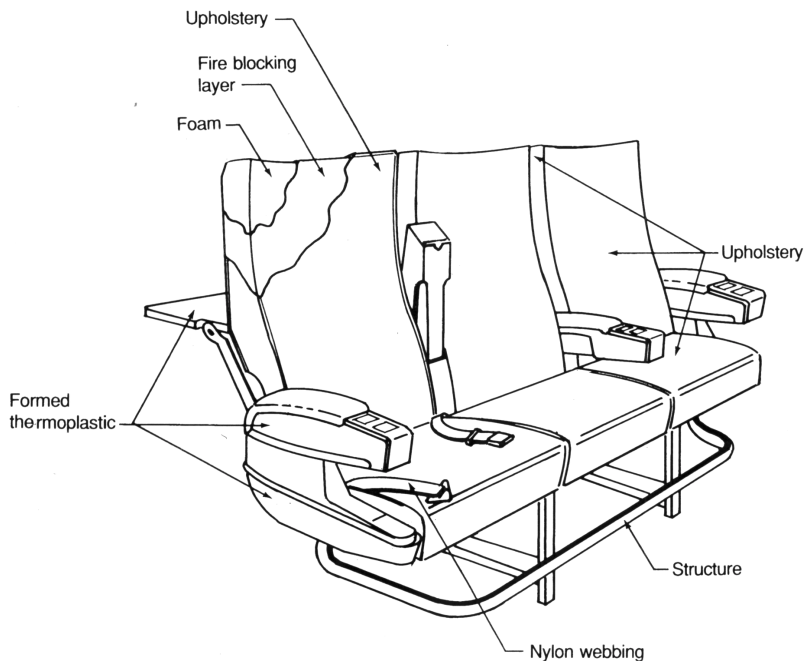

Figure C-1. Typical Seat Installation

C.2.1 Foam Cushions

Selection of foams for seats is based on requirements such as wear, comfort, flotation, flammability, and others. To meet these requirements, many different foams of various densities are used. The foam in the cushions is either molded to the final shape or cut from existing foam stock and bonded together with adhesives. Open cell urethane foams are most commonly used with densities as low as $1.98/\text{ft}^3$. If the cushion is to serve as a flotation device in emergency situations, the foam must be closed cell; polyethylene foams are often used for this. Neoprene, silicone, and modified urethane foams can be used for cushions to meet FAR 25.853(c) without a fire-blocking textile. They may also be used as fire blockers over conventional foams. The densities of these foams have a range of 3 to $4 \text{ lb}/\text{ft}^3$.

C.2.2 Upholsteries

Typical dress cover fabrics include wool, wool/nylon blends, leather, fire-retarded (FR) polyester, FR nylon, and vinyl. Wool blends with an FR treatment, typically a zirconium type, are by far the most common type of upholstery

in use and have proven to be one of the most reliable in passing FAR 25.853(b) and FAR 25.853(c). Many nondecorative fabrics are also used in seat installations; FR cotton muslin is used as a slip cover to allow easier installation of the dress cover.

C.2.3 Fire-Blocking Textiles

The use of fire-blocking textiles was required by FAR 121, Amendment 184, which required that seat cushions comply with FAR 25.853(c). To meet this regulation, textiles made of synthetic fibers, such as polybenzimidazole (PBI), aromatic polyamides, and glass, are woven or felted and used to encapsulate the foam. The weight of the fire-blocking textile required depends primarily on the foam construction and type with lower density foams normally requiring heavier fire-blocking layers.

C.2.4 Plastic Molding

Aircraft seats employ a wide variety of plastic moldings for items such as decorative closeouts, trim strips, food trays, and arm rests. Polycarbonate, acrylonitrile-butadiene-styrene (ABS), and decorative vinyls are commonly used for these purposes.

C.2.5 Structure

Most seat structures are made of aluminum; however, some manufacturers have introduced carbon composite structures to reduce weight.

C.3 Insulating Materials

The entire pressurized section of the aircraft is completely lined with thermal/acoustical insulation, which is by far the largest volume of nonmetallic material in an aircraft. The acoustical requirements for the insulation are more demanding than the thermal requirements. The insulation blanket construction used consists of a batting surrounded by a protective cover; however, in some applications, where the insulating material consists of foams or felts, a separate cover is not used. Insulation batting and covers are required to meet FAR 25.853(b).

C.3.1 Batting

Most of the thermal/acoustical insulation used is fibrous glass batting that is 0.42 to 0.6 lb/ft³ in density and held together with a water-repellent treated phenolic binder. The diameter of the glass fiber is very small, approximately 0.0006 inch for acoustical reasons. The material easily meets FAR 25.853(a) and FAR 25.855(a). In other insulation applications (e.g., used for air ducting), foams (e.g., urethane and polyimide) and felts (e.g., aromatic polyamides) are extensively used. In higher temperature areas, fibrous glass batting with a silicone binder (for temperatures up to 700°F) and ceramic batting (for temperatures up to 2,000°F) are used. Areas of application include engine pylons, nacelles, power units, and engine bleed air ducting.

C.3.2 Insulation Covers

The main reasons for covering insulation batting are to hold it in place and to keep out contaminants such as dust and fluids, especially water. Very thin plastic films (0.5 to 2 mils) of polyester or polyvinyl fluoride reinforced with nylon yarn are used extensively due to their light weight and good tear resistance. In areas that are subject to abuse, lightweight, abrasion-resistant coated fabrics such as vinyl-coated nylon and vinyl-coated fiberglass are used. Areas subject to higher temperature require the use of silicone-coated fiberglass, metallized fiberglass, or ceramic covers.

C.3.3 Insulation Installation

Insulation is installed using a variety of attachments, including hook and loop tape (Velcro), nylon fasteners, snaps, and splicing tapes.

C.4 Interior Panel Structures

Although a few monolithic laminate panels are used, most panels used in airplane interiors are sandwich structures. This type of construction is preferred for its high strength and stiffness to weight ratio. These panels are made basically of face sheets, adhesives, core, and decorative coverings, with small variations that depend on the requirements for the individual application. Typical panels are shown in figure C-2. These panels are used for ceilings, galleys, lavatories, sidewalls, baggage racks, floors, partitions, and closets. All panels used for these applications must meet FAR 25.853(a) and (a-1).

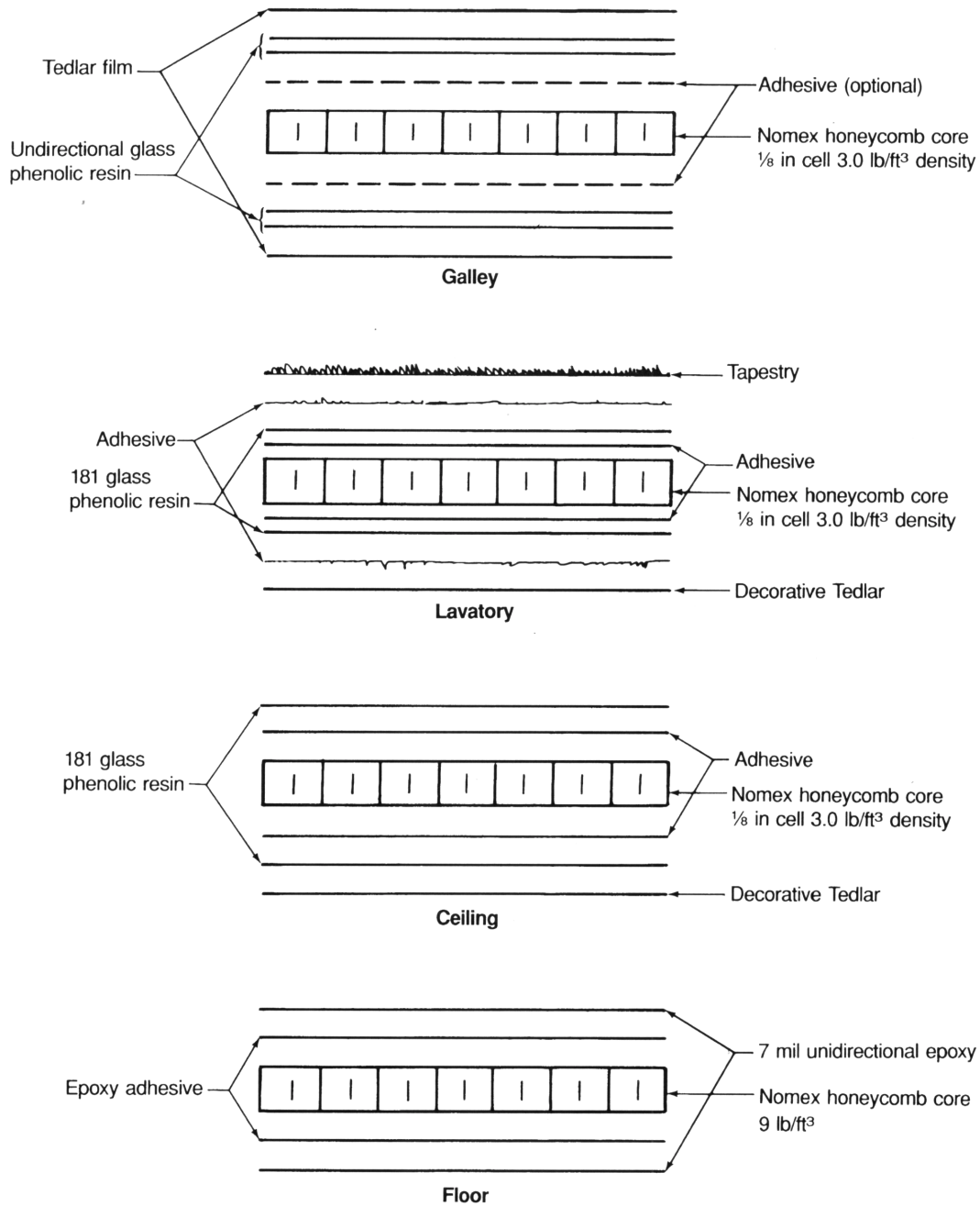

Figure C-2. Typical Panel Installation

C.4.1 Face Sheets

All panel faces consist of a resin system and a fiber reinforcement.

C.4.1.1 Fiber Reinforcement

The fiber reinforcement can either be unidirectional or woven. Fiberglass, aromatic polyamides, and graphite/carbon are used due to their high strength to weight ratio and good fire resistance. Fiberglass is the most common due to its low cost. Aromatic polyamides and carbon fibers are much higher in cost but their very high strength to weight ratio make them attractive in many applications.

C.4.1.2 Resin System

Epoxy resin systems were widely used in the middle 1960s. Later, beginning in the 1970s, phenolic resin systems began to replace epoxies because of their superior fire resistance and low smoke emissions, despite that phenolics generally are lower in strength. Today, the most prevalent resin systems are phenolic. Epoxy is still used in certain applications where strength considerations are important and/or where competing phenolic systems are not available.

C.4.2 Core

The core in a sandwich panel is most often a honeycomb structure to achieve the best physical properties at the minimum weight. Aluminum honeycomb has been used in cabin interiors; however, the most common type honeycomb is an aramid-based paper coated with a phenolic resin to stabilize the paper. Aramid honeycomb ranges in density from 1.5 pounds per cubic foot for lightweight ceiling panels to 9 pounds per cubic foot for floor panels; cell sizes range from 1/8 inch to 3/4 inch. Aramid honeycomb provides good fire resistance and can easily meet FAR 25.853(a) without face sheets. Other types of core materials that have been used include polyurethane, polyvinyl chloride, polyimide foams (to reinforce edges and fastener points), and balsa wood (for floor panels in passenger cabins and cargo holds).

C.4.3 Adhesives for Bonding Face Sheets to Core

Epoxy and modified phenolic film adhesives are used to bond face sheets to the core. Some face sheets employ a modified resin to allow bonding directly to the core and do not require a separate adhesive film.

C.4.4 Decorative Coverings for Panels

All interior panels have a decorative covering on surfaces that are visible to passengers. Decorative plastics, paint, wainscoting, and tapestries all serve both aesthetic and functional purposes. See figure C-3 for a description of decorative coverings used in a typical main cabin of an aircraft.

C.4.4.1 Plastic Laminates

Most surfaces that are in direct contact with passengers and crews or surfaces that require a lightweight cover have decorative plastic laminates. Galley and lavatory surfaces that face the aisle, ceilings, baggage racks, lavatory interiors, and door liners are typical applications for decorative plastic laminates. In high use areas, vinyls have been applied because of their good abrasion resistance. Surfaces that expect less abuse employ polyvinyl fluoride (PVF) or PVF/vinyl combinations. These materials have good cleanability and colorfastness. Many of the new decorative Tedlar laminates exhibit very low heat release, making them ideal for many interior surfaces that are required to meet FAR 25.853(a-1).

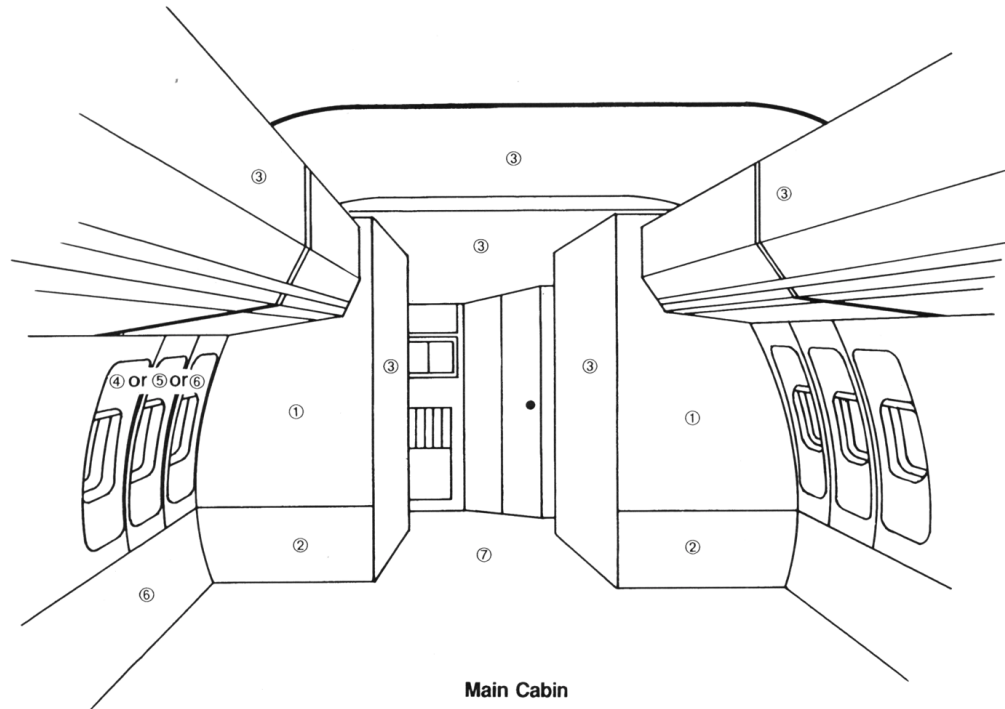

- ① Panel construction with tapestry cover.
- ② Panel construction with wainscot cover.
- ③ Panel construction with decorative plastic laminate.
- ④ Formed thermoplastic or laminate.
- ⑤ Formed aluminum with decorative plastic laminate.
- ⑥ Composite laminate with wainscot cover.
- ⑦ Panel construction with carpet cover.

Figure C-3. Typical Main Cabin

C.4.4.2 Decorative Textiles

Surfaces that face the passengers on galleys, lavatories, closets, and partitions are typically covered with decorative textiles. Plush, hand-tufted, 100 percent wool face tapestries are often used on upper panel surfaces. Lightweight carpeting or a grospoint construction is common on lower panel surfaces. A variety of materials and methods are used to make tapestries. The lower surface textile, wainscoting, is usually fabricated of treated wool or nylon with a very lightweight backing or no backing. With the new heat release regulation, most of the previously used tapestries and wainscoting can no longer be applied. Tapestry and wainscoting fabrics made from synthetics and wool/synthetic combinations are produced in order to meet the heat release requirements.

C.4.4.3 Paint

Interior polyurethane and water-based paints are used primarily on surfaces that see little abuse, such as those behind the pilots. Paint is also used on many small parts throughout an aircraft.

C.5 Floor Coverings

The type of floor covering used depends on the location in the aircraft. All floor coverings must meet FAR 25.853(b). Carpet covers most of the cabin floor, including the aisle and under the seats. Most aircraft have wool- or nylon-face yarns with polyester, polypropylene, cotton, or fiberglass backing yarns and a fire-retardant back coating. Wool-face yarns are treated with a fire retardant. Nylon carpets must have a highly fire-retardant back coating for fire resistance. Carpet underlays of felt are used in some aircraft for noise suppression. Areas where

fluid spills are likely, such as galleys and lavatories, use plastic floor coverings typically made of vinyl with a reinforcing fabric backing and an antislip surface.

C.6 Draperies

Draperies are used to close off sections of the aircraft such as galleys and to separate the classes of passenger service. Drapery fabrics are usually wool or polyester fabric that has been treated with a flame retardant.

C.7 Nonmetallic Air Ducting

Due to the relative compactness of an aircraft, much of the conditioned air ducting has to be routed around many different parts. This results in some very complex shapes. Nonmetallic ducting is used to create these complex parts because it is much less expensive to fabricate than aluminum ducting. There are three basic types of nonmetallic duct constructions: fiber-reinforced resin, thermoplastic, and rigid foam. All conditioned air ducting must meet FAR 25.853(b).

C.7.1 Fiber Reinforced

Fiber-reinforced resins consist of woven fiberglass with polyester, epoxy, or phenolic resin systems. Some aromatic polyamide/epoxy is also used. Ducts made from these materials are usually coated after curing on the outside with a polyester or epoxy resin to seal against leaks. Fiberglass impregnated with silicone rubber is the industry standard for duct boots because of flexibility, strength, low air permeability, and good fire resistance.

C.7.2 Thermoplastic

Thermoplastic ducting is typically made of vacuum-formed polycarbonate or polyetherimide. Thermoplastic ducts are not as strong as fiber-reinforced resin; however, thermoplastic ducts are much less costly to fabricate.

C.7.3 Foam

Polyimide or polyisocyanurate foam ducts are used for larger ducts with complex shapes and have the advantage of not requiring additional insulation. Foam ducts are popular for their low weight.

C.8 Linings (Nonpanel)

Linings are used where strength and flexibility are required to provide a contoured shape; in addition, linings provide an aesthetically pleasing surface and protect the assemblies behind the liner. Areas such as the exit door, flight deck, cabin sidewalls, door frames, and cargo holds utilize liners fabricated of reinforced resins or thermoplastics. Decorative sidewall liners made of formed aluminum are used in some aircraft. Depending on the application, the liners must meet FAR 25.853(a), (a-1), or (b) or FAR 25.855(a) or (a-1) or a combination.

C.8.1 Reinforced Resin

Linings that are subjected to passenger and food cart traffic are typically manufactured from plies of fabric-reinforced resin. Their flexibility, impact resistance, high strength, and low weight make them ideal for lower sidewall kick panels. Cargo liners required to meet FAR 25.855(a) and (a-1) are fabricated using fiberglass reinforced resins because of the burn-through and impact resistance.

C.8.2 Thermoplastics

Linings that see less abuse and do not require high strength are fabricated from thermoplastics because less expensive fabrication methods are used. Flight deck sidewalls, upper door liners, attendant stations, and closeouts are typical applications for vacuum and pressure formed thermoplastics such as ABS, polycarbonate, and polyetherimide. In many applications, thermoplastics are integrally pigmented and textured and do not require any decorative covering.

C.9 Electrical Components

C.9.1 Wire and Cable Insulation

Wire and cable insulation comprises a substantial amount of the nonmetallic material in an aircraft. For general wire and cable applications inside the pressure shell, the majority of the insulation used is polyimide (Kapton). Not quite as prevalent is irradiated, crosslinked, polyethylenetetrafluoroethylene. In some areas, aromatic polyamide braiding is used to cover power feeder cables for scuff resistance. For higher temperature and fuel areas polytetrafluoroethylene (PTFE) is used almost exclusively. Where very high temperature or burn-through resistance is a requirement, filled PTFE is typically used. Asbestos had been used as the filler in the past, but has been replaced by proprietary fibers. To withstand the high temperature requirements of fire zones, heavily nickel-plated copper wire is used to ensure continued operation of electrical equipment. All wire insulations must meet FAR 25.1359(d), and those located in fire zones must also meet FAR 25.1359(b).

C.9.2 Conduit and Tubing

Different types of conduit and tubing are used for electrical wires and components. Polyvinyl fluoride and polyolefin heat shrink tubing, silicone glass fiber braid, and extruded and convoluted nylon tubing are industry standards.

C.9.3 Connectors

Most connectors in an aircraft are made of Bakelite aluminum with silicone or hardened dielectric material inserts and have no specific FAR burn requirements. Connectors located in firewalls, however, must be fireproof and are made of low carbon or stainless steel to meet burnthrough requirements.

C.10 Firewalls

Firewalls are required around all designated fire zones (e.g., engine compressor, accessory sections) to isolate a fire (see figure C-4). Titanium and steel of at least 0.015-inch thickness are used as firewalls. Steel is the preferred material as it does not warp under heat to the extent titanium does. To provide even more burnthrough resistance in specific areas, resin-impregnated high-silica glass or coated niobium is used.

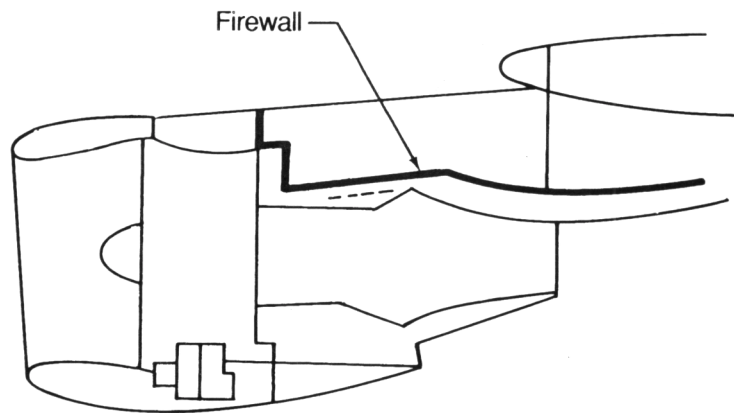

Figure C-4. Typical High Bypass Engine

C.11 Windows

All aircraft windows at present are fabricated from stretched cast polymethylmethacrylate. Stretched acrylic has the optical clarity, strength, low weight, and solvent resistance required. All windows must meet FAR 25.853(b-2).

C.12 Small Parts

Except for electrical wire and cable insulation and for small parts (such as knobs, handles, rollers, fasteners, clips, grommets, rub strips, pulleys, and small electrical parts) that the Administrator finds would not contribute significantly to the propagation of a fire, parts/materials not identified in FAR 25.853(a), (b), (b-1), or (b-2) shall not have a burn rate greater than 4 inches per minute when tested horizontally in accordance with FAR 25.853 (b-3).

Appendix D Regulatory Methodology Used by Other Countries

D.1 Introduction

Air commerce is very much an international business. Aircraft designed and built in one country are imported and operated in other countries. Airlines based in one country have route networks that extend to many other countries. A complicated set of international agreements is, therefore, required to ensure the safe design and operation of aircraft operated internationally and has led to the status that the regulatory methodologies used by most nations are relatively similar.

D.2 Foreign Airworthiness Authorities and Regulations

Each country is responsible for setting appropriate requirements and enforcement procedures to ensure the safe design and operation of aircraft in that country. This includes aircraft registered and operated in that country and foreign-registered aircraft operated to that country in international commerce.

Most countries have their own airworthiness authorities and codes or regulations to some degree of detail. In addition to their own regulations, many countries also accept sections of other countries' codes for aircraft certification and approval, particularly Federal Aviation Regulations (FARs) of the United States and British Civil Airworthiness Requirements (BCARs) of the United Kingdom. In addition, Joint Airworthiness Regulations (JARs) from the Joint Aviation Authorities of Europe.

Table D-1 identifies airworthiness authorities and additional country codes adopted for issuance of a certificate of airworthiness.

D.3 Regulations Covering Foreign Air Carriers

Airlines based in one country that wish to transport passengers and/or goods into another country must comply with the requirements imposed on foreign carriers by the host country before the service can start. Generally, such agreements are more or less reciprocal.

In the United States, the requirements are contained in FAR 129, "Operations: Foreign Air Carriers and Foreign Operators of U.S. Registered Aircraft Engaged in Common Carriage," and mandate essentially that the aircraft and aircrew involved be certificated in the country of registry, and that the operation of the aircraft observe the air traffic rules and procedures prescribed for U.S. air carriers.

In other countries, the requirements are generally similar to those in the United States.

D.4 Certification of Foreign-Manufactured Aircraft

Aircraft manufactured in one country are often sold and exported to other countries for operation. This is particularly true of large transport aircraft manufactured in the United States, the United Kingdom, and the Airbus consortium countries (France, Spain, West Germany, and the United Kingdom).

The aircraft must meet specified airworthiness regulations of the importing country and must receive from the exporting country whatever licenses or permits are needed for it to be exported.

During the 1950s and 1960s, large transport aircraft were manufactured almost exclusively in the United States, the United Kingdom, and the Soviet Union. Many of these aircraft were purchased and imported by other countries. Most countries not allied with the Soviet Union purchased and imported large transport aircraft from the United States or the United Kingdom. Since these aircraft were certificated to the FARs or the very similar BCARs, it was expeditious and beneficial for other countries to base their own regulations on FARs and/or BCARs.

Table D-1. Air Worthiness Authorities and Country Codes

Country	Airworthiness Authority	Airworthiness Standards
Argentina	Direccion Nacional de Aeronavegabilidad	Information Bulletins No. 13 and 24
Australia	Department of Transport Airworthiness Division	Australian Air Navigation Order 101
Brazil	Departamento de Aviacaco Civil	Brazilian Aeronautical Certification Requirements
Canada	Airworthiness Division Transport Canada	FAR Parts 23, 25, 27, 29, 31, 33, and 35 JAR 22 TSOs
Denmark	Director of Civil Aviation	FAR BCAR JAR
Finland	National Board of Aviation Flight Safety Department	JAR 25 FAR Finnish Aviation Regulations detail any deviations
France	Direction Generale de l'Aviation Civile (DGAC)	JAR 25 FAR Parts 23, 27, and 29
Germany, Federal Republic of	Luftfahrtbundesamt (LBA)	FAR Parts 23, 25, 27, and 29 JAR 22 and 25
Indonesia	Directorate General of Air Communications	Civil Aviation Safety Regulations, based on FAR Parts 23, 25, 27, 29, 33, 35, and 37
Ireland	Department of Transport Aeronautical Airworthiness Service	BCAR FAR
Italy	Ministero dei Trasporti Direzi- one Generale Dell'Aviazione Civile	Parts 223, 225, 226, 228, 231, 233, and 235 of RAI Technical Rules, based on FAR Parts 23, 25, 27, 29, 31, 33 and 35 JAR
Japan	Airworthiness Division Civil Aviation Bureau Ministry of Transport	Annex to Civil Aeronautics Regulations of Japan
Mexico	Direccion General de Aeronautica Civil	Reglamento de Operacion de Aeronaves Civiles y Circular relativos a certificados de aeronavegabilidad
Netherlands, Kingdom of	Aeronautical Inspection Directorate	Netherlands Airworthiness Requirements, based on JAR and FAR
New Zealand	Director of Civil Aviation Ministry of Transport	New Zealand Civil Airworthness Requirements C-1, C-2, C-3, and C-4
Norway	Civil Aviation Administration Aeronautical Inspection Department	JAR FAR BCAR
Sweden	Board of Civil Aviation Flight Safety Department	FAR JAR Swedish Civil Aviation Regulations detail any deviations
Switzerland	Federal Office for Civil Aviation	FAR Franch Airworthiness Code (LFSM) JAR German Airworthiness Code (LFSM) BCAR
United Kingdom	Civil Aviation Authority	BCAR JAR
United States	Federal Aviation Administration	FAR

Beginning in the 1970s, aircraft began to be manufactured in more countries. In addition, the aircraft manufacturing industry has an increasing number of international companies and, as a result, many multinational business ventures have evolved. Foreign governments have approached this growth in the airplane industry by organizing their own airworthiness authorities and regulations and by entering into international agreements regarding airplane certification.

D.4.1 Bilateral Airworthiness Agreements

A useful procedure to reduce the problems associated with certification of aircraft by importing countries is the Bilateral Airworthiness Agreement (BAA). These agreements generally state that for those requirements in the two countries' regulations that overlap, the importing country will accept the exporting country's certification of compliance. Requirements imposed by the importing country that are not included in the exporting country's regulations must be separately shown to have been met.

The United States negotiates BAAs primarily with countries who have an aeronautical product they desire to export to the United States. When a request is made to establish a BAA, the FAA must evaluate the foreign airworthiness authority's technical competence, capabilities, and regulatory authority, and the country's airworthiness laws and regulations to ensure that an equivalent level of safety will be met. Currently, the United States has 24 such agreements. Those countries have BAAs with the United States; those BAA components are identified in table D-2. A copy of each BAA can be found in Advisory Circular 21-18, "Bilateral Airworthiness Agreements."

BAAs are not considered to be trade agreements; they are technical agreements, existing only to facilitate the reciprocal acceptance of certification. Most BAAs address the following issues:

1. The importing country shall give the same validity to the certification given by the exporting country.
2. The aeronautical authority of the importing country shall have the right to make acceptance of any certification by the airworthiness authority of the exporting country. This depends on the product meeting any additional requirements that the importing country finds necessary that would be applicable for a similar product produced in the importing country.
3. Each airworthiness authority shall keep the other informed on all relevant laws, regulations, and requirements.
4. In the event of conflicting interpretations of a regulation, the interpretation of the country originating the relation shall prevail.

In the United States, the Federal Aviation Administration (FAA) implements BAAs through the export and import certification regulations of FAR Part 21.

D.4.2 Joint Airworthiness Regulations (JARs)

The Joint Aviation Authorities (JAA) is an associated body of the European Civil Aviation Conference (ECAC) representing the civil aviation regulatory authorities of a number of European States who have agreed to co-operate in developing and implementing common safety regulatory standards and procedures. This co-operation is intended to provide high and consistent standards of safety and a "level playing-field" for competition in Europe. Much emphasis is also placed on harmonizing the JAA regulations with those of the USA.

Table D-2. Summary of Products Eligible for U.S. Import Under Bilateral Agreements

BILATERAL COUNTRIES (Revised 1999)	Aircraft	Replacement/Modification Parts for Exported Aircraft	Aircraft Engines	Replacement/Modification Parts for Exported Engines	Propellers	Replacement/Modification Parts for Exported Propellers	Appliances	Replacement/Modification Parts for Exported Appliances	Materials	Parts	Subassemblies	Third Country Provisions	Maintenance	Agreement Date	See Reference Notes Number
Argentina	X	X	X	X	X	X	X	X	X	X	X			1991	
Australia	X	X	X	X	X	X	X	X	X	X	X	X		1975	1, 2, 3
Austria	X	X	X	X	X	X								1959	
Belgium	X	X	X	X	X	X	X	X	X	X	X	X		1973	1, 2
Brazil	X	X	X	X	X	X	X	X	X	X	X	X		1976	1, 2
Canada	X	X	X	X	X	X	X	X	X	X	X	X	X	1984	1, 2
China	X	X					X							1991	4
Czech Republic	X	X	X	X	X	X	X	X						1970	
Denmark	X	X	X	X	X	X	X	X	X	X	X	X		1970	2
Finland	X	X					X	X						1974	5
France	X	X	X	X	X	X	X	X	X	X	X	X		1973	1, 2
Germany	X	X	X	X	X	X	X	X	X	X	X	X	X	1999 1998	1, 2, 13
Indonesia													X	1992	6
Israel	X	X	X	X	X	X	X	X	X	X	X			1974	2
Italy	X	X	X	X	X	X	X	X	X	X	X	X		1973	1, 2
Japan	X	X	X	X	X	X	X	X	X	X	X	X		1977	1, 2
Malaysia	X	X					X							1997	7
Netherlands	X	X	X	X	X	X	X	X	X	X	X	X		1974	1, 2
New Zealand	X	X	X	X	X	X	X	X	X	X	X			1979	2, 8
Norway	X	X					X	X						1978	
Poland	X	X	X	X	X	X	X	X	X	X	X	X		1980	2, 9
Romania	X	X												1976	10
Russia	X	X							X					1998	11
Singapore							X	X	X	X	X	X		1981	1, 2, 12
South Africa	X	X	X	X	X	X	X	X	X	X	X			1984	2
Spain	X	X					X	X						1978	
Sweden	X	X	X	X	X	X	X	X	X	X	X	X		1973	1, 2
Switzerland	X	X	X	X	X	X	X	X	X	X	X			1977	2
United Kingdom	X	X	X	X	X	X	X	X	X	X	X	X		1972	1, 2

The JAA Membership is based on signing the “JAA Arrangements” document originally signed by the then current member States in Cyprus in 1990. Based on these Arrangements and related commitments, the JAA’s objectives and functions may be summarised as follows:

Objectives:

- To ensure, through co-operation on regulation, common high levels of aviation safety within the Member States.
- To achieve a cost effective safety system so as to contribute to an efficient aviation industry.

- To contribute, through the uniform applications of common standards, to fair and equal competition within the member states.
- To promote, through international co-operation, the JAA standards and system to improve the safety of aviation worldwide.

Functions:

- To develop and adopt Joint Aviation Requirements (JARs) in the fields of aircraft design and manufacture, aircraft operations and maintenance, and the licensing of aviation personnel.
- To develop administrative and technical procedures for the implementation of JARs.
- To implement JARs and the related administrative and technical procedures in a co-ordinated and uniform manner.
- To adopt measures to ensure, whenever possible, that pursuance of the JAA safety objective does not unreasonably distort competition between the aviation industries of Member States or place companies of Member States at a competitive disadvantage with companies of non-Member States.
- To provide the principal center of professional expertise in Europe on the harmonization of aviation safety regulation.
- To establish procedures for joint certification of products and services and where it is considered appropriate to perform joint certification.
- To co-operate on the harmonization of requirements and procedures with other safety regulatory authorities, especially the Federal Aviation Administration (FAA).
- Where feasible, to co-operate with foreign safety regulatory authorities, especially the FAA, on the certification of products and services.

JAA's work was started in 1970 (when it was known as the Joint Airworthiness Authorities). Originally its objectives were only to produce common certification codes for large aeroplanes and for engines. This was to meet the needs of European industry, particularly for products manufactured by international consortia (eg., Airbus). Since 1987 its work has been extended to operations, maintenance, licensing and certification/design standards for all classes of aircraft. Common procedures and the approval of design, production, and maintenance organizations are covered. A single Joint Certification team, working on behalf of all the JAA countries, is used for certification of new aircraft and engines. After the successful completion of the evaluations, Type Certificates are issued simultaneously, and on a common basis, by all States.

The JAA originated as the Authorities' response to the technical and economic needs of the European aviation industry. However, since 1 January 1992, JAA codes, as they are completed, are referenced in the European Community Regulation on Harmonized Technical Standards and become law in the EC States.

Industry is fully represented in committees and working groups developing requirements and procedures and in a joint assembly and joint boards where policy issues are debated.

The JAA, as presently constituted, carries out its tasks of approval, certification and safety monitoring using staff of the national authorities, who also retain the responsibility for the legal findings of granting licenses and certificates, etc. The JAA Headquarters is responsible for the process of rulemaking, harmonization and standardization, (using specialist staff from the national authorities), the decision-making system, the "infrastructure," and various related tasks.

The relevant committees and working groups for the work in the Materials Handbook are the following:

- JAA Research Committee

The committee is tasked to promote, coordinate, and disseminate the results of aviation safety research carried out in JAA countries and to prepare proposals for aviation safety research funds by the European Commission and to liaison with the EU as necessary.

- Project Advisory Group on Occupant Survivability

This group, reporting to the JAA Research Committee, is tasked to advise on the Research Committee on matters related to Occupant Survivability

- The Cabin Safety Study Group

This group reports to the JAA Certification Director at the JAA Headquarters.

The purpose of the Cabin Safety Study group is to consider the Cabin Safety Requirements related to the design and construction and equipment requirements for the JAR-25.

In 1979 a milestone was passed when JAR 25, which was based on FAR 25 and covered large transport aircraft, was adopted. France, the Netherlands, the United Kingdom, and West Germany have adopted JAR 25 as their sole, common code for certification of large transport aircraft. Incidentally, FAR 25 Amendments are not automatically adopted into JAR 25; they must first be accepted by the Steering Committee before incorporation.

REFERENCE NOTES

1. These bilateral agreements contain a third-party country provision which provides for import/export certification of products by the CAA of a country other than the country of manufacture. In these instances, the exporting country must certify that the products conform to the design covered by the certificate or approval of the importing country (which would be other than country of manufacture) and that the products are in proper state of airworthiness. This provision only applies when all three countries (i.e., manufacturing, importing, and exporting countries) have similar agreements for the reciprocal acceptance of such certifications covering the same class of products. The specific text of the applicable bilateral agreements should be consulted for any limitations.
2. The U.S. has bilateral agreements with these countries which provide for the reciprocal acceptance of conformity inspections (certificates of conformity) for components (i.e., materials, parts, and subassemblies) produced within the limits of each particular bilateral, provided that
 - a. an agreement exists between the manufacturers in the importing and exporting countries;
 - b. the component is of such complexity that a determination of conformity cannot readily be made by the manufacturer in the importing country;
 - c. the airworthiness authorities of the importing country have notified the airworthiness authorities of the exporting country of the applicable design, test, and quality control requirements; and
 - d. the authority of the exporting country is willing to undertake the conformity inspection task.
3. The U.S./Australian BAA contains a two-party country provision which provides for
 - a. reciprocal certification whereby Australia can issue an export certificate for a U.S.-manufactured product located in that country which is to be exported to the U.S.

- b. conversely, the U.S. can issue an export certificate for an Australian-manufactured product that is located in the U.S. and is to be exported to Australia.
 - c. such certifications will state that the product conforms to the importing country's type design and is in a proper state of airworthiness.
4. The Schedule of Implementation Procedures for the U.S./China BAA provides for U.S. acceptance of Chinese TSO appliances, fixed-wing aircraft not exceeding 12,500 lbs., and commuter category airplanes up to 19 passengers with a maximum certificated takeoff weight of 19,000 lbs.
 5. Although this bilateral agreement contains a provision for including appliances and replacement or modification parts, therefore, by mutual consent of both countries' aviation authorities, no appliances nor replacement/modification parts have been included to date.
 6. The Schedule of Implementation Procedures for the U.S./Indonesia BAA is limited, when exporting aeronautical products from Indonesia to the U.S., to the production approval and airworthiness certification or approval of civil aeronautical products for which the Indonesian manufacturer holds the manufacturing rights to a U.S. type certificate under a licensing agreement with a U.S. manufacturer or with a manufacturer in another state with which the U.S. has an agreement for the reciprocal acceptance of type design certifications.
 7. The U.S./Malaysia Implementation Procedures for Airworthiness provides for U.S. acceptance of Malaysian TSO appliances and small metal airplanes of up to nine passengers with a maximum certificated takeoff weight of 12,500 lbs.
 8. The U.S./New Zealand BAA is limited to
 - a. Export from New Zealand to the U.S.:
 - i. Fixed-wing aircraft constructed in New Zealand not exceeding a maximum weight of 12,500 pounds and their spare (replacement) parts;
 - ii. Appliances for use on civil aircraft and their spare (replacement) parts;
 - iii. Components for fixed-wing aircraft not exceeding 12,500 pounds
 - b. Export from U.S. to New Zealand:
 - i. U.S.-constructed civil aircraft, aircraft engines and propellers and their spare (replacement) parts;
 - ii. Appliances for use on civil aircraft and their spare (replacement) parts;
 - iii. Components for use on civil aircraft and related products.
 9. The U.S./Poland BAA is limited to
 - a. Products which may be exported from Poland to U.S. (or U.S. possession):
 - i. Civil gliders and replacement/modification parts therefore designed and produced in Poland;
 - ii. Piston engines of 1,000 h.p. or less with associated propellers and accessories and replacement/modification parts therefore produced in Poland;
 - iii. Small fixed-wing aircraft of 12,500 pounds or less and replacement/modification parts therefore;
 - iv. Helicopters with associated accessories and replacement/modification parts therefore;
 - v. Turbine engines and replacement/modification parts therefore; and,

- vi. Components and appliances for U.S.-manufactured products of the types specified in subparagraphs i., ii., iii., iv., and v. above.
 - b. Products which may be exported from the U.S. to Poland:
 - i. U.S.-designed and produced aircraft, engines, propellers, components, appliances, and replacement/modification parts therefore; and
 - ii. U.S.-produced components and appliances for Polish-manufactured products and replacement and spare parts therefore.
10. The U.S./Romania bilateral provides for U.S. acceptance of Romanian and motorized gliders only.
11. The U.S./Russia Implementation Procedures for Airworthiness limit U.S. acceptance to Russian—
- a. New and used, metal aircraft having up to nine passengers and a maximum certificated takeoff weight of 12,500 lbs or less,
 - b. New and used transport category aircraft (cargo configuration only) with FAA-certificated engines, propellers, and avionics, approved for Category I and Category II instrument approach procedures; and
 - c. Metallic materials.
- Aircraft eligible for import to the U.S. must have been designed to the applicable Russian aviation regulations (APs). Aircraft built to early regulations are not covered under this agreement.
12. The U.S./Singapore BAA is limited to –
- a. Export from Singapore to the U.S.:
 - i. U.S.-designed component for use in the manufacture of an aircraft or related product in the U.S. (Note: Such components may also be shipped directly from Singapore to other States [other than the U.S.], when authorized by the FAA, for use as a replacement or modification part on U.S.-registered aircraft located in the other State) and;
 - ii. Appliances approved under Federal Aviation Regulations, § 21.617, Technical Standard Order Design Approval.
 - iii. Note 1 of this document (third party country provision) only applies to those products listed under the foregoing subparagraphs 1. and 2. exported from Singapore to the U.S.
 - b. Export from the U.S. to Singapore:
 - i. All products listed in the summary chart (page 1 of this appendix); and
 - ii. Note 1 of this document (third-party country provision) applies to all products listed in the summary chart, exported from the U.S. to Singapore.
13. On August 23, 1999, Implementation Procedures for Airworthiness were concluded under the U.S./Germany Bilateral Aviation Safety Agreement. This IPA includes reciprocal acceptance of all aeronautical products and STCs. (The IPA replaces the 1974 U.S./Germany Bilateral Airworthiness Agreement.) A Maintenance Implementation Procedure was concluded with Germany in 1997 for reciprocal acceptance of repair station certifications (contact AFS-300).

BILATERAL AGREEMENTS

	Country	Agreement Type	Application/Scope of U.S. Acceptance
1.	Argentina	<ul style="list-style-type: none"> BAA Schedule of Implementation Procedures 	Applies to all aeronautical products, including components
2.	Australia	<ul style="list-style-type: none"> BAA 	Applies to all aeronautical products and certain components
3.	Austria	<ul style="list-style-type: none"> BAA 	Applies to all aeronautical products
4.	Belgium	<ul style="list-style-type: none"> BAA 	Applies to all aeronautical products and certain components
5.	Brazil	<ul style="list-style-type: none"> BAA 	Applies to all aeronautical products and certain components
6.	Canada	<ul style="list-style-type: none"> BAA Schedule of Implementation Procedures 	Applies to all aeronautical products, including components
7.	China	<ul style="list-style-type: none"> BAA Schedule of Implementation Procedures 	Applies to fixed-wing aircraft not exceeding 12,500 lbs., commuter category airplanes up to 19 passengers with a maximum certificated takeoff weight of 19,000 lbs. or less, and TSO appliances
8.	Czech Republic	<ul style="list-style-type: none"> BAA Operating Procedures 	Applies to all aeronautical products
9.	Denmark	<ul style="list-style-type: none"> BAA 	Applies to all aeronautical products and certain components
10.	Finland	<ul style="list-style-type: none"> BAA 	Applies to gliders and aircraft appliances
11.	France	<ul style="list-style-type: none"> BAA 	Applies to all aeronautical products and certain components
12.	Germany	<ul style="list-style-type: none"> BASA Executive Agreement Implementation Procedures for Airworthiness 	Applies to all aeronautical products and certain components
13.	Indonesia	<ul style="list-style-type: none"> BAA Schedule of Implementation Procedures 	Applies to production oversight in Indonesia under licensing agreements with U.S. manufacturers
14.	Israel	<ul style="list-style-type: none"> BAA 	Applies to all aeronautical products, appliances, and components
15.	Italy	<ul style="list-style-type: none"> BAA 	Applies to all aeronautical products and certain components
16.	Japan	<ul style="list-style-type: none"> BAA 	Applies to all aeronautical products and certain components
17.	Malaysia	<ul style="list-style-type: none"> BASA Implementation Procedures for Airworthiness 	Applies to TSO appliances and small, all metal airplanes up to nine passengers with a maximum certificated takeoff weight of 12,500 lbs.
18.	Netherlands	<ul style="list-style-type: none"> BAA 	Applies to all aeronautical products and certain components
19.	New Zealand	<ul style="list-style-type: none"> BAA 	Applies to fixed-wing aircraft not exceeding 12,500 lbs.
20.	Norway	<ul style="list-style-type: none"> BAA 	Applies to all categories of civil aircraft and appliances
21.	Poland	<ul style="list-style-type: none"> BAA 	Applies to certain components, gliders, piston engines of 1,000 h.p. or less, associated propellers, helicopters, turbine engines, and fixed-wing aircraft not exceeding 12,500 lbs.

BILATERAL AGREEMENTS

	Country	Agreement Type	Application/Scope of U.S. Acceptance
22.	Romania	<ul style="list-style-type: none"> • BAA 	Applies to gliders and motorized gliders
23.	Russia	<ul style="list-style-type: none"> • BASA Executive Agreement • Implementation Procedures for Airworthiness 	Applies to small, all metal airplanes up to nine passengers with a maximum certificated takeoff weight of 12,500 lbs and to transport category cargo airplanes (both with FAA-certificated engines, propellers, and avionics).
24.	Singapore	<ul style="list-style-type: none"> • BAA 	Applies to TSO appliances and components
25.	South Africa	<ul style="list-style-type: none"> • BAA 	Applies to all categories of civil aircraft
26.	Spain	<ul style="list-style-type: none"> • BAA 	Applies to all categories of civil aircraft and appliances
27.	Sweden	<ul style="list-style-type: none"> • BAA 	Applies to all aeronautical products and certain components
28.	Switzerland	<ul style="list-style-type: none"> • BAA 	Applies to all aeronautical products and certain components
29.	United Kingdom	<ul style="list-style-type: none"> • BAA 	Applies to all aeronautical products and certain components

Appendix E

Aircraft Industries Internal Test Methods and Guidelines

As written, Federal Aviation Administration (FAA) test procedures for meeting the requirements set forth in Federal Aviation Regulation (FAR) 25 sometimes contain incomplete documentation (e.g., the firewall test). In order to establish standardized guidelines for these test procedures, including more detailed instructions and safety precautions, individual aircraft manufacturers have established some of their own internal documentation. This documentation, as well as having detailed instructions, is at times also used to certify different materials to applicable FARs. Table E-1 contains a listing of each FAR fire test and the equivalent company internal test method document number, as well as the applicable American Society for Testing and Materials (ASTM) standard, if any. Other testing related to fire safety (such as toxicity) is also listed. These documents are normally available from the listed company.

Table E-1. Industry Test Documentation

FAA Regulation		Industry Test Documentation									
Burn Test Description	FAR Paragraph No.	Airbus	British Aerospace	Boeing	Douglas	Shanghai Aircraft Research Institute	Daimler-Benz Aerospace	ASTM			
Piping/hose assemblies	25.1183 (a)		ISO/DIS 2685								
Fire zone wire	25.1359 (b)		ISO/DIS 2685		MIL-C-25038						
Wire insulation	25.1359 (d)	ATS 1000.001	BACM 1555A		DMS 1501		ATS 1000.001	ASTM-F 777			
60-second vertical	25.853 (a)	ATS 1000.001	BACM 1551A	BSS 7230 F1	DMS 1510		ATS 1000.001	ASTM F 501			
OSU heat release	25.853 (a-1)		BAEP 4508	BSS 7322	DMS 2277		W-TE335-304/87	ASTM Modified E 906*			
12-second vertical	25.853 (b)	ATS 1000.001	BACM 1555A	BSS 7230 F2	DMS 1511		ATS 1000.001	ASTM F 501			
2.5-in/min horizontal	25.853 (b-2)	ATS 1000.001	BACM 1555A	BSS 7230 F3	DMS 1505		ATS 1000.001	ASTM F 776			
4-in/min horizontal	25.853 (b-3)	ATS 1000.001	BACM 1555A	BSS 7230 F4	DMS 1507		ATS 1000.001	ASTM F 776			
Oil burner seats	25.853 (c)		BAEP 4508	BSS 7303	DMS 2274	HB 7263	TBD	*			
Fire containment	25.853(d)		BACM 1555A	Document No. D6T11679	DMS 1513						
3 second, 45 degree	25.855 (a)	ATS 1000.001	BACM 1555A	BSS 7230 F5	DMS 1508		ATS 1000.001	ASTM F 1103			
Oil burner, cargo liner	25.855 (a-1)		BAEP 4508	BSS 7323	DMS 2273		TBD	*			
Radiant heat test	TSO-C69a, Appendix 2	TSO		BSS 7315				ASTM F 828			
Other NBS smoke	25.853 (a-1)	ATS 1000.001	BAEP 4625	BSS 7238	DMS 1500		ATS 1000.001	ASTM F 814			
Toxicity		ATS 1000.001	BAEP 4623	BSS 7239	DMS 2294	HB 7066	ATS 1000.001				
Lot							ASTM D 2863	ASTM D 2863			

*ASTM test method being written by subcommittee F7.06.

Appendix F—Laboratories Actively Using Fire Test Procedures

The companies listed in table F-1 are actively using the fire test procedures discussed in this Handbook
 (This list is not complete or inclusive.)

Table F-1. Laboratories Actively Using Fire Test Procedures

Laboratory Company Name	Fire Test Conducted										
	Bunsen Burner	Heat Release	Smoke Test	Cargo Oil Burner	Seat Oil Burner	Evac Slide Radiant Heat	Powerplant Fire test	Powerplant Hose Assembly	Powerplant Elec Wire	Powerplant Connectors	Aircraft Blanket Test
AaBe Textiles B. V. De Posthoornstraat 5; 5048 AS Tilburg Postbus 5126; 5004 EC Tilburg, Holland 31 13 46 57 506	X			X	X						
Accufleet 16511 Hedgecroft Drive, Suite 210 Houston, TX 77060 281-999-0033	X			X	X						X
① Albany International Research Company 777 West Street PO Box 9114 Mansfield, MA 02048-9114 508-339-7300	X	X	X								
Atlas Electric Devices Company 4114 N. Ravenswood Avenue Chicago, IL 60613 773-327-4520	X	X ②									
① The Boeing Company Boeing Technology Services PO Box 3707 M/S: 9R-28 Seattle, WA 98124 206-277-4600	X	X ②	X	X ①	X ①	X	X ①	X	X	X	
Boeing-Douglas Products Division 3855 Lakewood Boulevard Dept. EY2, M/C D001-0018 Long Beach, CA 90845 562-593-4427	X	X ②	X	X	X	X	X	X	X	X	
Custom Products, Inc. PO Box 1141 Mooreville, NC 28115 704-663-4159	X ①				X ①						

① Commercial testing services offered.

② FAA-accepted heat release apparatus

③ The organizations may be able to conduct additional fire tests not identified above. Only tests conducted regularly are specified.

Table F-1. Laboratories Actively Using Fire Test Procedures (Continued)

Laboratory Company Name	Fire Test Conducted										
	Bunsen Burner	Heat Release	Smoke Test	Cargo Oil Burner	Seat Oil Burner	Evac Slide Radiant Heat	Powerplant Fire test	Powerplant Hose Assembly	Powerplant Elec Wire	Powerplant Connectors	Aircraft Blanket Test
Delsen Testing Laboratories 1024 Grand Central Avenue Glendale, CA 91201 818-247-4106	X	X	X	X							
① Driessen Aircraft Interior Systems 10781 Forbes Avenue Garden Grove, CA 92843 714-265-2911	X	X ②	X								
①, ③ East-West Technology Corporation 119 Cabot Street West Babylon, NY 11704 516-420-0530	X			X	X		X	X	X	X	
①, ③ East-West Technology Corporation P.O. Box 220716 West Palm Beach, FL 33422-0716 561-776-7339	X			X	X		X	X	X	X	
③ Environ Laboratories, Inc. 9725 Girard Avenue South Minneapolis, MN 55431-2621 1-800-826-3710										X	
Fiberite, Inc. 2055 E. Technology Circle Tempe, AZ 85284 602-730-2127	X	X	X								
GE Plastics Burn Lab, Building 30 One Lexan Lane Mt. Vernon, IN 47620 (812) 831-7654	X	X	X ②								
① The Govmark Organization, Inc. PO Box 807 Bellmore, NY 11710 516-293-8944	X	X	X	X	X ③		X			X ③	
Herb Curry, Inc. 1701 Leonard Road P.O. Box 753 Mt. Vernon, IN 47620-0753 (812) 838-6703	X	X	X ②								
① Hoechst AG Brandversuchsanlage, C 369 D-65926 Frankfurt/M, Germany 49 69 305 3476	X	X	X		X						

① Commercial testing services offered.

② FAA-accepted heat release apparatus

③ The organizations may be able to conduct additional fire tests not identified above. Only tests conducted regularly are specified.

Table F-1. Laboratories Actively Using Fire Test Procedures (Continued)

Laboratory Company Name	Fire Test Conducted										
	Bunsen Burner	Heat Release	Smoke Test	Cargo Oil Burner	Seat Oil Burner	Evac Slide Radiant Heat	Powerplant Fire test	Powerplant Hose Assembly	Powerplant Elec Wire	Powerplant Connectors	Aircraft Blanket Test
ISOVOLTA Aktiengesellschaft A-2355 Wr. Neudorf/Austria 43 2236 605 315		X ②									
① Lantal Textiles PO Box 1330 4901 Langenthal, Switzerland 41 62 916 7171	X	X	X		X						
③ Omega Point Laboratories 16015 Shady Falls Road Elmendorf, TX 78112-9784 210-635-8100	X	X	X								
③ ORTECH Corporation Fire & Flammability Centre 2395 Speakman Drive Mississauga, Ontario, L5K 1B3, Canada 905-822-4111	X	X	X		X						
Schneller, Inc. PO Box 670 Kent, OH 44240 330-673-1400	X	X ②	X								
① SGS U.S. Testing Company, Inc. 5555 Telegraph Road Los Angeles, CA 90040 213-838-1600	X	X ②	X	X	X		X	③			
① SGS U.S. Testing Company, Inc. 291 Fairfield Avenue Fairfield, NJ 07004 973-575-5252											X
Shanghai Aircraft Research Institute Longhua Airport Building, PO Box 232-003 Shanghai 200232, People's Republic of China 86 21 643 88 606	X	X	X	X	X						
Skandia, Inc. 5181 Falcon Road Rockford, IL 61020 815-227-1611	X				X						

① Commercial testing services offered.

② FAA-accepted heat release apparatus

③ The organizations may be able to conduct additional fire tests not identified above. Only tests conducted regularly are specified.

Table F-1. Laboratories Actively Using Fire Test Procedures (Continued)

Laboratory Company Name	Fire Test Conducted										
	Bunsen Burner	Heat Release	Smoke Test	Cargo Oil Burner	Seat Oil Burner	Evac Slide Radiant Heat	Powerplant Fire test	Powerplant Hose Assembly	Powerplant Elec Wire	Powerplant Connectors	Aircraft Blanket Test
① Southwest Research Institute Department of Fire Technology 6220 Culebra Road, PO Drawer 28510 San Antonio, TX 78284 210-522-2410	X	X ②	X		③						
① Swedish National Testing and Research Institute (Sveriges Provnings-och Forskningsinstitut) Fire Technology/Box 857 SE-501 15 Boras, Sweden 46 33 16 50 00	X		X								
Traveltex Interiors Paris Nord II 78, allée des Erables 93420 Villepinte, France 33 1 49 38 18 18	X		X ③								
① Underwriters Laboratories Inc. Fire Protection Department 333 Pingsten Road Northbrook, IL 60062 847-272-8800	X	X	X	③	③	③	③	③	③	X	
Vatell Corporation PO Box 66 Christiansburg, VA 24073 540-961-3576		X		X	X	X	X	X			
Weber Aircraft 1300 E. Valencia Drive Fullerton, CA 92631 714-449-3000	X				X						

① Commercial testing services offered.

② FAA-accepted heat release apparatus

③ The organizations may be able to conduct additional fire tests not identified above. Only tests conducted regularly are specified.

Appendix G Commercial Manufacturers of Fire Test Equipment

The following companies manufacture test and/or calibration equipment used to conduct the fire tests described in this Handbook.

Table G-1. Commercial Manufacturers of Fire Test Equipment

EQUIPMENT DESCRIPTION	SUPPLIER/MANUFACTURER
Test Chamber used for Vertical, Horizontal, and 45-Degree Bunsen Burner Test described in Chapters 1, 2, and 3.	Atlas Electric Devices Co. 4114 Ravenwood Avenue Chicago, IL 60613 (723) 327-4520
	The Govmark Organization, Inc. P.O. Box 807 Bellmore, NY 11710 (516) 293-8944
	Fire Testing Technology 2 Friar's Lane Mill Valley, CA 94941 (415) 388-8278
Test apparatus used for 60-Degree Bunsen Burner Test described in Chapter 4.	Atlas Electric Devices Co. 4114 Ravenwood Avenue Chicago, IL 60613 (723) 327-4520
	Fire Testing Technology 2 Friar's Lane Mill Valley, CA 94941 (415) 388-8278
Rate of Heat Release Apparatus described in Chapter 5.	Atlas Electric Devices Co. 4114 Ravenwood Avenue Chicago, IL 60613 (723) 327-4520
	The Govmark Organization, Inc. P.O. Box 807 Bellmore, NY 11710 (516) 293-8944
	Fire Testing Technology 2 Friar's Lane Mill Valley, CA 94941 (415) 388-8278

Table G-1. Commercial Manufacturers of Fire Test Equipment (Continued)

EQUIPMENT DESCRIPTION	SUPPLIER/MANUFACTURER
Smoke Density Chamber described in Chapters 6 and 19.	Newport Scientific, Inc. 8246-E Sandy Court Jessup, MD 20794 (301) 498-6700 The Govmark Organization, Inc. P.O. Box 807 Bellmore, NY 11710 293-8944 Fire Testing Technology 2 Friar's Lane Mill Valley, CA 94941 (415) 388-8278
Gun type oil burner described in Chapters 8, 9, 11, and 12.	Park Oil Burner Manufacturing Co. 1413 Marmora Avenue Atlantic City, NJ 08401 (609) 344-8058 (Note: Does not supply cone.)
Water-cooled calorimeter described in Chapters 5, 8, 9, 11, and 12.	Vatell Corporation P.O. Box 66 Christiansburg, VA 24073 (540) 961-3576 (Supplier of Thermogage™ products for heat-flux sensing and calibration) Medtherm Corporation P.O. Box 412 Huntsville, AL 35804 (205) 837-2000
Insulation/backing material used for specimen preparation, calorimeter mounting, baffle, etc. described in Chapters 5, 6, 7, 8, 11, and 12.	Thermal Ceramics P.O. Box 923 Dept. 140 Augusta, GA 30903 (706) 796-4200
Oil Burner Test Rigs described in Chapters 7, 8, 12, and 15.	The Govmark Organization, Inc. P.O. Box 807 Bellmore, NY 11710 (516) 293-8944
Aircraft Blanket Tester described in Chapter 18.	The Govmark Organization, Inc. P.O. Box 807 Bellmore, NY 11710 (516) 293-8944