

INCH-POUND

AN929 Rev 12
w/AMENDMENT 2
7 April 2011
SUPERSEDING
AN929 Rev 12
16 February 2010

DETAIL SPECIFICATION SHEET

CAP INSERT, ASSEMBLY, PRESSURE SEAL,
FLARED TUBE FITTING

This specification is approved for use by all Departments and Agencies
of the Department of Defense .

The requirements for acquiring the product described herein shall consist of this specification sheet and
SAE-AS4841.

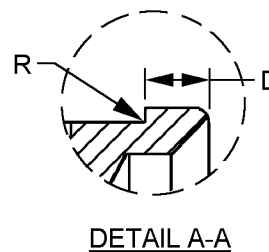
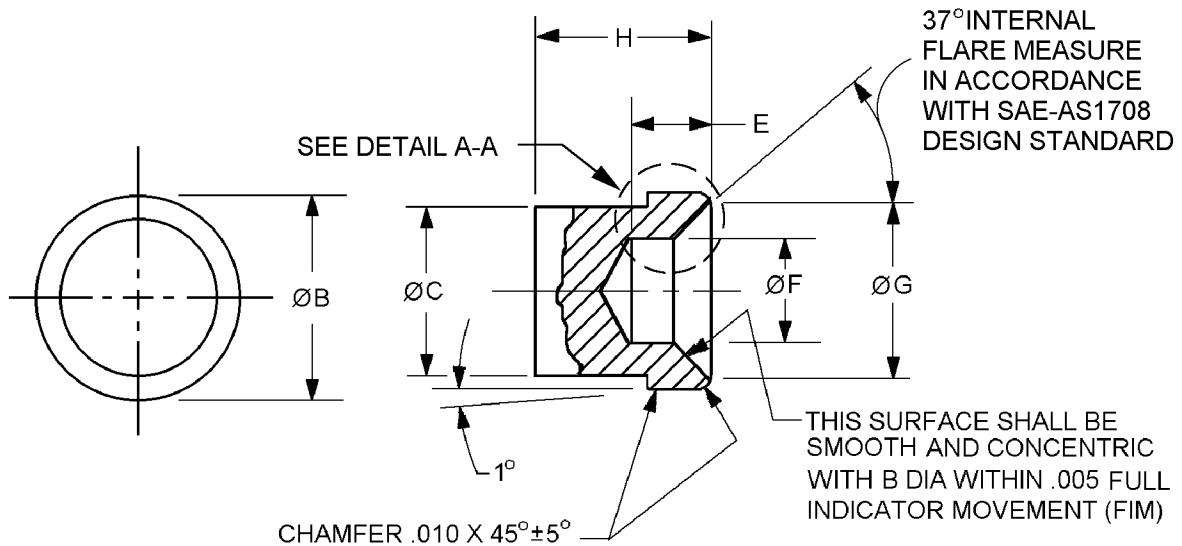
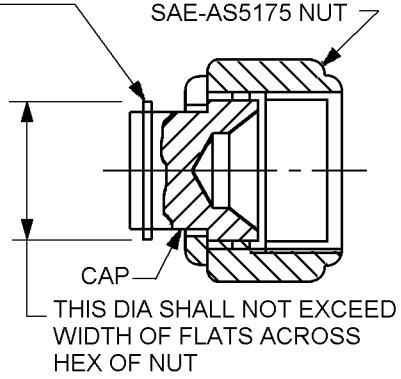
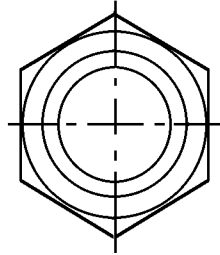

FIGURE 1. Cap.

AN929 Rev 12
 w/AMENDMENT 2

METHOD OF PREVENTING MOVABLE CAP FROM FALLING OUT, OPTIONAL WITH MANUFACTURER UPON APPROVAL BY THE PROCURING ACTIVITY



DRILL NO. 45 (.082) HOLE THROUGH HOLE TO BE APPROX. CENTERED BETWEEN END OF NUT AND END OF CAP

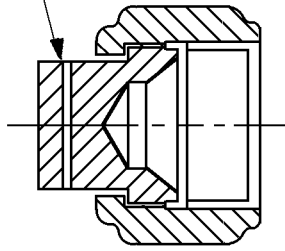

DETAIL FOR DRILLING
 AN929A2 AND AN929A3

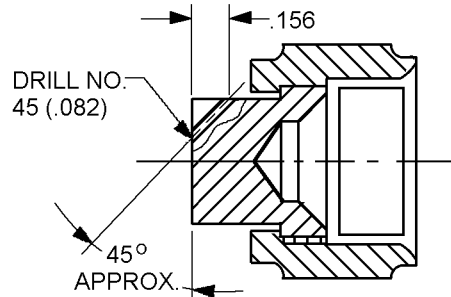

DETAIL FOR DRILLING
 AN929A4 AND LARGER

CAP DRILLED FOR ATTACHING SAFETY CHAIN

CAP ASSEMBLY

CAP ASSEMBLY

Inches	mm
.082	2.08
.156	3.96

FIGURE 1. Cap – Continued.

AN929 Rev 12
 w/AMENDMENT 2

Dash number	Tube OD inches (mm)	B dia inches (mm) +.000 -.003 (0.08)	C dia. inches (mm)	D inches (mm)	E inches (mm)
-2	.125 (3.18)	.263 (6.68)	.156 (3.96)	.156 (3.96)	.125 (3.18)
-3	.188 (4.78)	.325 (8.26)	.219 (5.56)	.219 (5.56)	
-4	.250 (6.35)	.378 (9.60)	.281 (7.14)	.203 (5.16)	
-5	.313 (7.95)	.441 (11.20)	.344 (8.78)	.219 (5.56)	.141 (3.58)
-6	.375 (9.53)	.503 (12.78)	.422 (10.72)	.266 (6.76)	.156 (3.96)
-8	.500 (12.70)	.683 (17.35)	.547 (13.89)	.313 (7.95)	.172 (4.37)
-10	.625 (15.88)	.799 (20.29)	.672 (17.07)	.281 (7.14)	.250 (6.35)
-12	.750 (19.05)	.974 (24.74)	.813 (20.65)		
-16	1.000 (25.40)	1.224 (31.09)	1.063 (27.00)	.297 (7.54)	.313 (7.95)
-20	1.250 (31.75)	1.536 (39.01)	1.328 (33.73)	.375 (9.53)	
-24	1.500 (38.10)	1.786 (45.36)	1.594 (40.49)	.406 (10.31)	.375 (9.53)
-28	1.750 (44.45)	2.161 (54.89)	1.875 (47.63)	.500 (12.70)	
-32	2.000 (50.80)	2.411 (61.24)	2.141 (54.38)	.578 (14.68)	.500 (12.70)
-40	2.500 (63.50)	2.911 (73.94)	2.641 (67.08)	.625 (15.88)	.688 (17.48)
-48	3.000 (76.20)	3.411 (86.64)	3.156 (80.16)	.688 (17.48)	

Dash number	F dia.	G dia inches (mm) +.000 -.005 (0.13)	H inches (mm)	R radius max inches (mm)
-2	.094 (2.39)	.218 (5.54)	.531 (13.49)	.005 (0.13)
-3	.156 (3.96)	.250 (6.35)		
-4	.172 (4.37)	.300 (7.62)		
-5	.234 (5.94)	.360 (9.14)	.563 (14.30)	.010 (0.25)
-6	.297 (7.54)	.440 (11.18)	.625 (15.88)	
-8	.391 (9.93)	.575 (14.61)	.750 (19.05)	
-10	.438 (11.13)	.685 (17.40)	.875 (22.23)	
-12	.563 (14.30)	.885 (22.48)		
-16	.813 (20.65)	1.103 (28.02)		
-20	1.078 (27.38)	1.413 (35.89)	1.000 (25.40)	
-24	1.313 (33.35)	1.661 (42.19)	1.125 (28.58)	
-28	1.547 (39.29)	2.034 (51.66)	1.375 (34.93)	
-32	1.781 (45.24)	2.284 (58.01)	1.438 (36.53)	
-40	2.000 (50.80)	2.784 (70.71)	1.750 (44.45)	
-48	2.500 (63.50)	3.284 (83.41)	1.813 (46.05)	

NOTES:

1. Dimensions are in inches.
2. Metric equivalents are given for information only.
3. Fittings shall be free of all burrs and slivers.
4. Unless otherwise specified tolerances for three point decimals ± 0.010 inch (0.25 mm).
5. For design features purposes, this standard takes precedence over documents referenced herein.

FIGURE 1. Cap - Continued.

AN929 Rev 12
 w/AMENDMENT 2

REQUIREMENTS:

Dimensions and configurations: See figure 1.

Material: See table I herein, procurement specification SAE-AS4841.

TABLE I. Material cap assembly.

Cap insert			Nut SAE-AS5175		
Designator	Material	Alloy	Designator	Material	Alloy
CS	Steel	1137/4130	Blank	Steel	1137/4130
J	CRES	304	J	CRES	304 or 316
K	CRES	316	K	CRES	304 or 316
S	CRES	347	J or K	CRES	304 or 316
T 1/	Titanium	64Al-4V	T	Titanium	64Al-4V
W	Aluminum	7075-T73	W	Aluminum	7075-T73

1/ Not for use with oxygen or potable water.

Finish: See SAE-AS4841.

Part or Identifying Number (PIN):

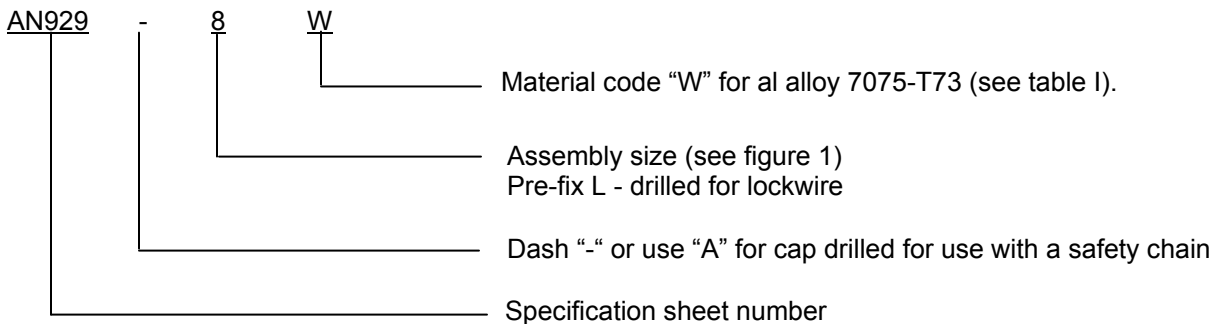

PIN Examples:

AN929-8W identifies a cap assembly .500 inch (tube), aluminum.

AN929-L8J identifies a cap assembly .500 inch (tube), nut drilled for lockwire, CRES.

AN929A8S identifies a cap assembly .500 inch (tube), insert drilled for attachment of safety chain, CRES.

Supersession data: Due to stress corrosion cracking aluminum alloys 2014 and 2024 blank designator has been replaced by aluminum alloy 7075 "W" designator example: AN929-8 use AN929-8W.

AN929 assemblies which consist of a cap and an SAE-AS5175 nut shall be fastened together for shipping or stock purposes in a manner acceptable to the procuring activity.

AN929 Rev 12
w/AMENDMENT 2

Amendment notations. The margins of this specification are marked with vertical lines to indicate modifications generated by this amendment. This was done as a convenience only and the Government assumes no liability whatsoever for any inaccuracies in these notations. Bidders and contractors are cautioned to evaluate the requirements of this document based on the entire content irrespective of the marginal notations.

Referenced documents. In addition to SAE-AS4841, this document references the following:

SAE-AS1708
SAE-AS5175

CONCLUDING MATERIAL

Custodians:
Navy - AS
Air Force - 99
DLA - CC

Preparing activity:
DLA - CC
(Project 4730-2011-070)

Review activity:
Air Force - 71

NOTE: The activities listed above were interested in this document as of the date of this document. Since organizations and responsibilities can change, you should verify the currency of the information above using the ASSIST Online database at <https://assist.daps.dla.mil>.