

USER SYMBOLS
 NAVY - MC
 ARMY - MU

REVIEWER SYMBOLS
 USAF - 80
 ARMY - AV

* Author/creator information is current as of the date of this document.
 For future coordination of changes to this document, draft circulation
 should be based on the information in the current 000158.

This document is to be used for use by all Departments
 & Agencies of the Department of Defense. It is to be used
 as a reference only and not for construction. It shall
 be used in accordance with the instructions on the drawing.

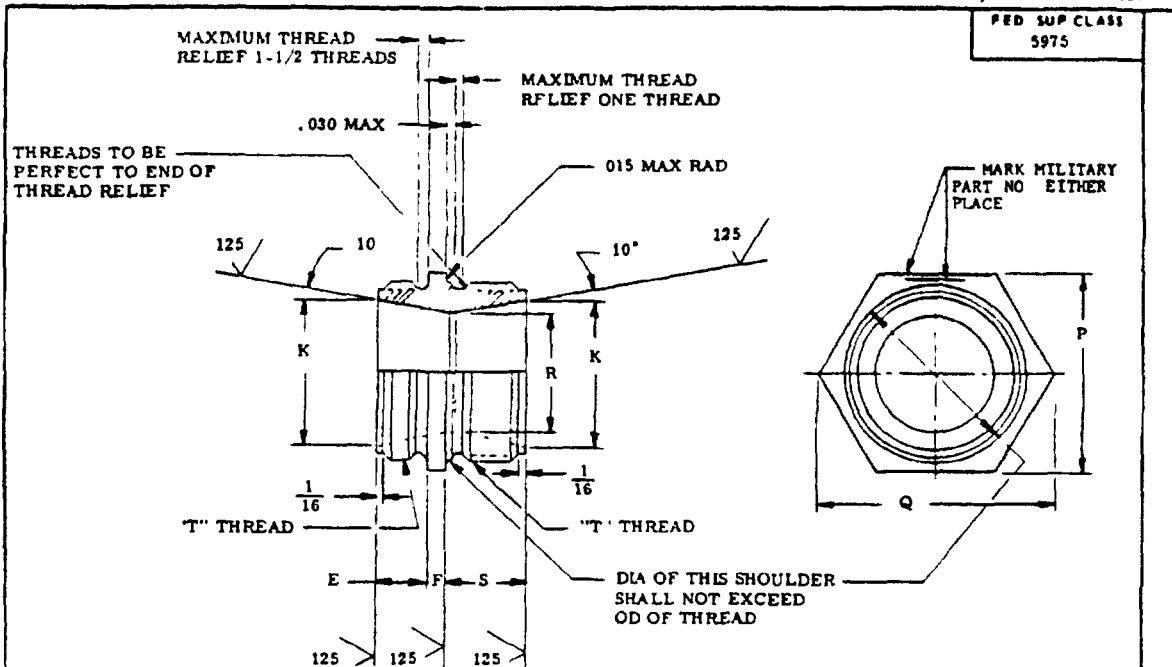

AN PART NO	CONDUIT SIZE	T THREAD	E	F	h DIA	P	Q APPROX	R DIA	S
AN3058-3	3, 16	5000-28 UNEF-2A	3/8	1/8	332	11/16	51.64	198	5.8
-4	1 1/4	6250-24 UNEF-2A	3/8	1/8	394	13/16	15.16	260	5.8
-6	3/8	7500-20 UNEF-2A	3/8	1.8	519	15/16	1-3.32	385	5.8
-8	1/2	8750-20 UNEF-2A	3/8	3/16	669	1-1/16	1-15.64	510	11.16
-10	5/8	1 0000-20 UNEF-2A	3/8	3/16	794	1-1/4	1-7/16	635	11.16
-12	3/4	1 1870 18 NEF-2A	3/8	3/16	920	1-3/8	1-19.32	760	11/16
16	1	1 4370-18 NEF-2A	3/8	3/16	1 214	1-5/8	1-7.8	1 010	11.16
-20	1-1/4	1 7500-18 NS-2A	7/16	3/16	1 469	2	2 5/16	1 261	3/4
-24	1-1/2	2 0000-18 NS-2A	1/2	3/16	1 724	2-3/16	2-17/32	1 511	13/16
-28	1-3/4	2 2500-16 UN-2A	1/2	1/4	1 976	2-7/16	2-13/16	1 761	7/8
-32	2	2 5000-16 UN-2A	9/16	1/4	2 229	2-13/16	3-1/4	2 011	15/16
AN3058-40	2-1/2	3 0000-16 UN-2A	5/8	1/4	2 744	3-3/8	3-37/64	2 512	1

ADDITIONAL REQUIREMENTS

- MATERIAL ALUMINUM ALLOY QQ-A-225/5 (2017-74) QQ-A-601, CLASS 4 QQ-A-591 OR COMMERCIAL GRADE SUITABLE TO THE PROCURING ACTIVITY
- SURFACE TEXTURE THE SURFACE TEXTURE SHALL BE IN ACCORDANCE WITH ANSI B46 1-1962 CADMIUM PLATE, QQ-A-16, TYPE II, CLASS 2.
- REMOVE ALL BURRS AND SHARP EDGES
- THREADS SHALL BE IN ACCORDANCE WITH MIL-S-7742 EXCEPT 1 7500-18 NS-2A AND 2 0000-18 NS-2A WHICH SHALL BE IN ACCORDANCE WITH ANSI B1 1-1960
- DIMENSIONS IN INCHES UNLESS OTHERWISE SPECIFIED, TOLERANCES FRACTIONS ± 1/64, DECIMALS ± 0.05 ANGLES ± 1/2

REFERENCED DOCUMENTS SHALL BE OF THE ISSUE IN EFFECT ON DATE OF INVITATIONS FOR BID

⑥ STANDARD REVISED AND REDRAWN

P.A. NAVY - AS Other Code USAF - 85 ARMY - EL	AERONAUTICAL STANDARD	AN3058
	COUPLING ELECTRICAL CONDUIT RIGID	
PROCUREMENT SPECIFICATION NONE	SUPERSEDES	SHEET 1 OF 1

APPROVED 25 MAR 40 REVISED ⑥ 31 JULY 1974

