

FED. SUP CLASS.
 5306

AN101901
 THRU
 AN102000

MATERIAL IDENTIFICATION PER
 AMS2800. RAISED OR DEPRESSED
 .010 MAX

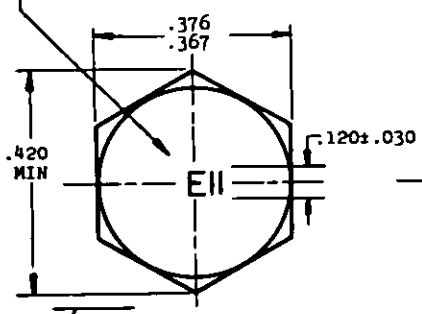

CHAMFER 30° TO .375 DIA
 (OPPOSITE SIDE OPTIONAL)

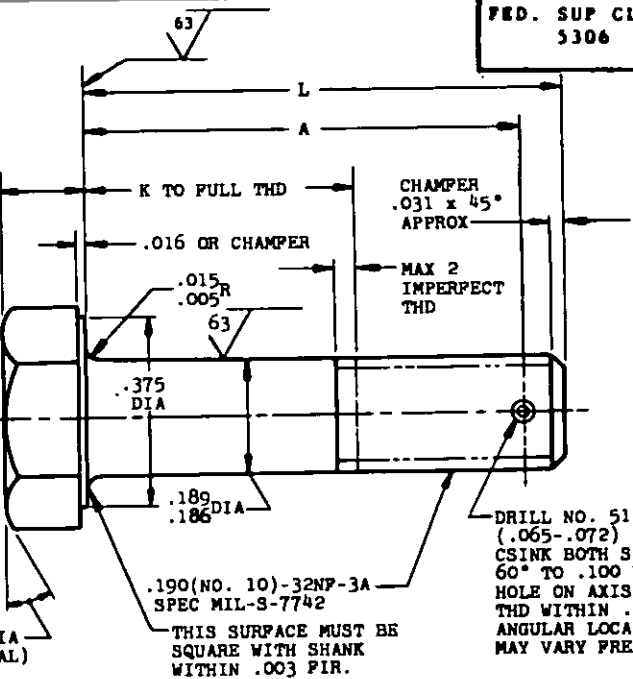

DRILL NO. 51
 (.065-.072)
 CSINK BOTH SIDES
 60° TO .100 DIA
 HOLE ON AXIS OF
 THD WITHIN .005.
 ANGULAR LOCATION
 MAY VARY FREELY

SECTION THRU THREAD PROFILE

L	A	K +.000 -.060	PART NO.	L	A	K +.000 -.060	PART NO.	L	A	K +.000 -.060	PART NO.
				1.250	1.140	.688	AN101920	3.625	3.515	3.062	AN101941
				1.312	1.202	.750	AN101921	3.750	3.640	3.188	AN101942
				1.375	1.265	.812	AN101922	3.875	3.765	3.312	AN101943
				1.438	1.328	.875	AN101923				
				1.500	1.390	.938	AN101924				
				1.625	1.515	1.062	AN101925				
				1.750	1.640	1.188	AN101926				
.375	.265	(a)	AN101906	1.875	1.765	1.312	AN101927				
.438	.328	(a)	AN101907	2.000	1.890	1.438	AN101928				
.500	.390	(a)	AN101908	2.125	2.015	1.562	AN101929				
.562	.452	(a)	AN101909	2.250	2.140	1.688	AN101930				
.625	.515	(a)	AN101910	2.375	2.265	1.812	AN101931				
.688	.578	.125	AN101911	2.500	2.390	1.938	AN101932				
.750	.640	.188	AN101912	2.625	2.515	2.062	AN101933				
.812	.702	.250	AN101913	2.750	2.640	2.188	AN101934				
.875	.765	.312	AN101914	2.875	2.765	2.312	AN101935				
.938	.828	.375	AN101915	3.000	2.890	2.438	AN101936				
1.000	.890	.438	AN101916	3.125	3.015	2.562	AN101937				
1.062	.952	.500	AN101917	3.250	3.140	2.688	AN101938				
1.125	1.015	.562	AN101918	3.375	3.265	2.812	AN101939				
1.188	1.078	.625	AN101919	3.500	3.390	2.938	AN101940				

(a) THREAD TO HEAD. MAXIMUM TWO IMPERFECT THREADS.

- NOTE: (1) SHANK SHALL BE STRAIGHT WITHIN .004 FIR PER INCH OF BOLT LENGTH.
 (2) THE CONCENTRICITY OF THREAD PD IN RELATION TO THE SHANK SHALL BE WITHIN .006 FIR.
 (3) THE CONCENTRICITY OF THE SHANK IN RELATION TO THE WASHER FACE DIAMETER AND HEXAGON SHALL BE WITHIN .011 FIR.

MATERIAL: STEEL AMS6322
 HARDNESS: ROCKWELL C26-32
 FINISH: CADMIUM PLATE AMS2400
 SURFACE ROUGHNESS: AS107

MANUFACTURING SPECIFICATION: AMS7452 PARTS SUBJECT TO MAGNETIC INSPECTION PER AMS2640.
 INSPECTION: ALL PARTS SHALL UNDERGO MAGNETIC INSPECTION IN ACCORDANCE WITH AMS2640.
 BREAK SHARP EDGES .003-.015 UNLESS OTHERWISE SPECIFIED.
 DIMENSIONS IN INCHES. UNLESS OTHERWISE SPECIFIED: TOLERANCES; LINEAR DIMENSIONS ±.010, ANGULAR DIMENSIONS ±2°.
 DO NOT USE UNASSIGNED PART NUMBERS.

INACTIVE FOR NEW DESIGN AFTER 3 MARCH 1969 NO SUPERSEDING STANDARD.

THIS STANDARD WAS DEVELOPED COOPERATIVELY BY THE ENGINE AND PROPELLER UTILITY PARTS COMMITTEE OF THE SAE.

P.A. AF-11 CUST. NAVY-AS ARMY-AV	AIR FORCE-NAVY AERONAUTICAL STANDARD	AN101901 THRU AN102000
	BOLT - HEX HEAD, DRILLED SHANK, .190-32	

DISTRIBUTION STATEMENT A. Approved for public release; distribution is unlimited.
 NOTE: This drawing was approved by Joint action of the Air Force and Navy Departments as the AF-Personal-Shop standard for this product. This drawing represents all dimensional standards for the same product and will become effective for the procurement of replacement parts, or for use in new design, not later than 6 months after the latest date of approval above.

APPROVED 8 June 49 REVISED 1 Aug 54 3 Mar 69 30 June 1988