

FED. SUP. CLASS.  
 5306

AN101201  
 THRU  
 AN101300

MATERIAL IDENTIFICATION PER  
 AMS2800. RAISED OR DEPRESSED  
 .010 MAX

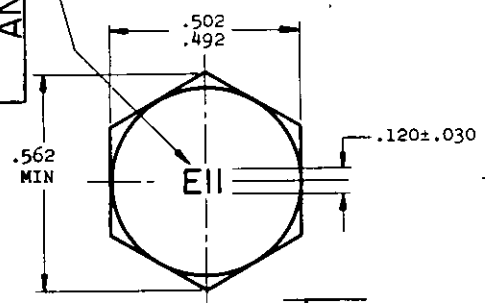

SECTION THRU THREAD PROFILE

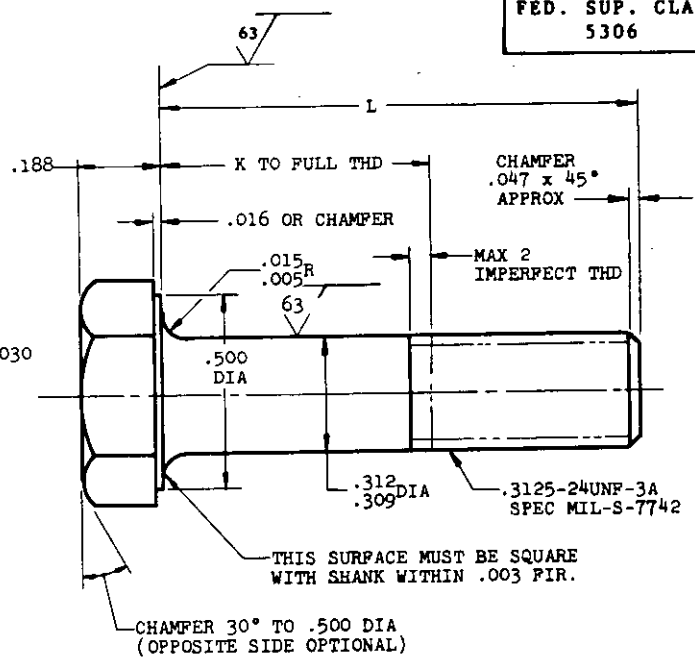

L	K +.000 -.060	PART NO.	L	K +.000 -.060	PART NO.	L	K +.000 -.060	PART NO.	L	K +.000 -.060	PART NO.
.625	(a)	AN101206	1.375	.688	AN101218	2.750	2.062	AN101232	4.500	3.812	AN101246
.688	(a)	AN101207	1.438	.750	AN101219	2.875	2.188	AN101233	4.625	3.938	AN101247
.750	(a)	AN101208	1.625	.938	AN101222	3.250	2.562	AN101236	5.000	4.312	AN101250
.812	.125	AN101209	1.688	1.000	AN101223	3.375	2.688	AN101237	5.125	4.438	AN101251
.875	.188	AN101210	1.750	1.062	AN101224	3.500	2.812	AN101238	5.250	4.562	AN101252
.938	.250	AN101211	1.875	1.188	AN101225	3.625	2.938	AN101239	5.375	4.688	AN101253
1.000	.312	AN101212	2.000	1.312	AN101226	3.750	3.062	AN101240	5.500	4.812	AN101254
1.062	.375	AN101213	2.125	1.438	AN101227	3.875	3.188	AN101241	5.625	4.938	AN101255
1.125	.438	AN101214	2.250	1.562	AN101228	4.000	3.312	AN101242	5.750	5.062	AN101256
1.188	.500	AN101215	2.375	1.688	AN101229	4.125	3.438	AN101243	5.875	5.188	AN101257
1.250	.562	AN101216	2.500	1.812	AN101230	4.250	3.562	AN101244	6.000	5.312	AN101258
1.312	.625	AN101217	2.625	1.938	AN101231	4.375	3.688	AN101245			

(a) THREAD TO HEAD. MAXIMUM TWO IMPERFECT THREADS.

- NOTE: (1) SHANK SHALL BE STRAIGHT WITHIN .003 FIR. PER INCH OF BOLT LENGTH.  
 (2) THE CONCENTRICITY OF THREAD PD IN RELATION TO THE SHANK SHALL BE WITHIN .006 FIR.  
 (3) THE CONCENTRICITY OF THE SHANK IN RELATION TO THE WASHER FACE DIAMETER AND HEXAGON SHALL BE WITHIN .015 FIR.

MATERIAL: STEEL AMS6322

HARDNESS: ROCKWELL C26-32

FINISH: CADMIUM PLATE AMS2400

SURFACE ROUGHNESS: AS107

MANUFACTURING SPECIFICATION: AMS7452

INSPECTION: ALL PARTS SHALL UNDERGO MAGNETIC INSPECTION IN ACCORDANCE WITH AMS2640.  
 BREAK SHARP EDGES .003-.015 UNLESS OTHERWISE SPECIFIED.

DIMENSIONS IN INCHES. UNLESS OTHERWISE SPECIFIED: TOLERANCES; LINEAR DIMENSIONS ±.010, ANGULAR DIMENSIONS ±2°.

DO NOT USE UNASSIGNED PART NUMBERS.

INACTIVE FOR NEW DESIGN AFTER 3 MARCH 1969 NO SUPERSEDING STANDARD.

THIS STANDARD WAS DEVELOPED COOPERATIVELY BY THE ENGINE AND PROPELLER UTILITY PARTS COMMITTEE OF THE SAE.

P.A. AF-11  
 CUST. NAVY-AS  
 ARMY-AV

AIR FORCE-NAVY AERONAUTICAL STANDARD

BOLT - HEX HEAD .3125-24

AN101201  
 THRU  
 AN101300

DISTRIBUTION STATEMENT A. Approved for public release; distribution is unlimited.

NOTE: This drawing was approved by joint action of the Air Force and Navy Departments as the Air Force-Navy standard for this product. This drawing supersedes all untested standard drawings for the same product and shall become effective for the procurement of aeronautical supplies, or for use in new design, not later than 6 months after the latest date of approval shown.

APPROVED 8 June 49 REVISED 1 31 Aug 54 3 Mar 69 130 June 1986