

FED. SUP. CLASS.
 5306

AN10101
 THRU
 AN101200

MATERIAL IDENTIFICATION PER
 AMS2800. RAISED OR DEPRESSED
 .010 MAX

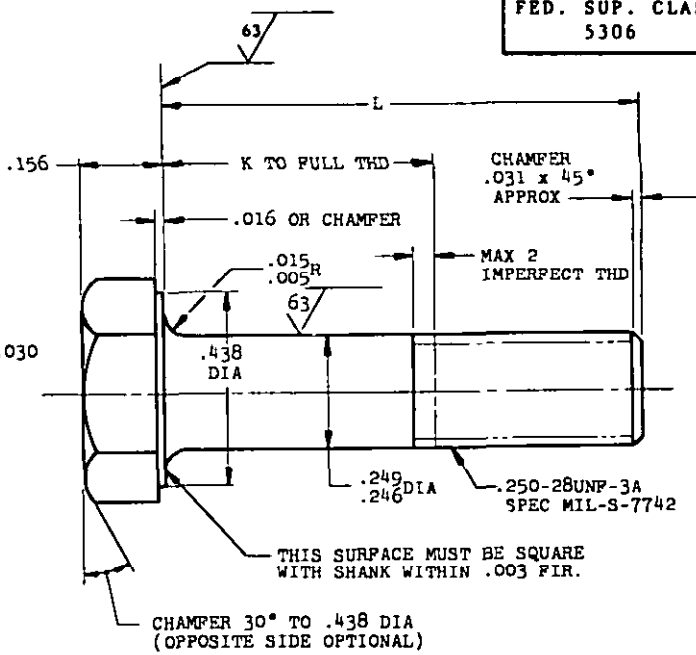
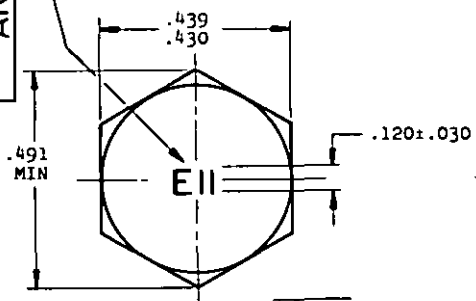

SECTION THRU THREAD PROFILE

L	K +.000 -.060	PART NO.	L	K +.000 -.060	PART NO.	L	K +.000 -.060	PART NO.	L	K +.000 -.060	PART NO.
.500	(a)	AN101106	1.312	.688	AN101119	2.625	2.000	AN101133	4.375	3.750	AN101147
.562	(a)	AN101107	1.375	.750	AN101120	2.750	2.125	AN101134	4.500	3.875	AN101148
			1.438	.812	AN101121	2.875	2.250	AN101135	4.625	4.000	AN101149
.625	(a)	AN101108	1.500	.875	AN101122	3.000	2.375	AN101136	4.750	4.125	AN101150
.688	(a)	AN101109	1.562	.938	AN101123	3.125	2.500	AN101137	4.875	4.250	AN101151
.750	.125	AN101110	1.625	1.000	AN101124	3.250	2.625	AN101138	5.000	4.375	AN101152
.812	.188	AN101111	1.688	1.062	AN101125	3.375	2.750	AN101139	5.125	4.500	AN101153
.875	.250	AN101112	1.750	1.125	AN101126	3.500	2.875	AN101140	5.250	4.625	AN101154
.938	.312	AN101113	1.875	1.250	AN101127	3.625	3.000	AN101141	5.375	4.750	AN101155
1.000	.375	AN101114	2.000	1.375	AN101128	3.750	3.125	AN101142	5.500	4.875	AN101156
1.062	.438	AN101115	2.125	1.500	AN101129	3.875	3.250	AN101143	5.625	5.000	AN101157
1.125	.500	AN101116	2.250	1.625	AN101130	4.000	3.375	AN101144	5.750	5.125	AN101158
1.188	.562	AN101117	2.375	1.750	AN101131	4.125	3.500	AN101145	5.875	5.250	AN101159
1.250	.625	AN101118	2.500	1.875	AN101132	4.250	3.625	AN101146	6.000	5.375	AN101160

(a) THREAD TO HEAD. MAXIMUM TWO IMPERFECT THREADS.
 NOTE: (1) SHANK SHALL BE STRAIGHT WITHIN .003 FIR PER INCH OF BOLT LENGTH.
 (2) THE CONCENTRICITY OF THREAD PD IN RELATION TO THE SHANK SHALL BE WITHIN .006 FIR.
 (3) THE CONCENTRICITY OF THE SHANK IN RELATION TO THE WASHER FACE DIAMETER AND HEXAGON SHALL BE WITHIN .013 FIR.

MATERIAL: STEEL AMS6322
 HARDNESS: ROCKWELL C26-32
 FINISH: CADMIUM PLATE AMS2400
 SURFACE ROUGHNESS: AS107

MANUFACTURING SPECIFICATION: AMS7452
 INSPECTION: ALL PARTS SHALL UNDERGO MAGNETIC INSPECTION IN ACCORDANCE WITH AMS2640.
 BREAK SHARP EDGES .003-.015 UNLESS OTHERWISE SPECIFIED.

DIMENSIONS IN INCHES. UNLESS OTHERWISE SPECIFIED: TOLERANCES; LINEAR DIMENSIONS ±.010, ANGULAR DIMENSIONS ±2°.

DO NOT USE UNASSIGNED PART NUMBERS.

INACTIVE FOR NEW DESIGN AFTER 3 MARCH 1969 NO SUPERSEDING STANDARD.

THIS STANDARD WAS DEVELOPED COOPERATIVELY BY THE ENGINE AND PROPELLER UTILITY PARTS COMMITTEE OF THE SAE.

P.A. AF - 11 Cust. Navy - AS Army - AV	AIR FORCE-NAVY AERONAUTICAL STANDARD	AN10101 THRU AN101200
	BOLT - HEX HEAD .250-28	

DISTRIBUTION STATEMENT A. Approved for public release; distribution is unlimited.
 NOTICE: When Government drawings, specifications, or other data are used for any purpose other than in connection with a definitely related Government procurement operation, the United States Government thereby incurs no responsibility, nor any obligation whatsoever; and the fact that the Government may have furnished, furnished, or in any way supplied the said drawings, specifications, or other data is not to be regarded by implication or otherwise as in any manner licensing the holder or any other person or corporation, or employing any rights or permission in manufacturer, use, or sell any patented invention that may in any way be related thereto.
 NOTES: This drawing was approved by joint action of the Air Force and Navy Departments as the Air Force-Navy standard for this product. This drawing supersedes all antecedent standard drawings for the same product and shall become effective for the procurement of aeronautical supplies, or for use in new designs, not later than 6 months after the latest date of approval shown.

APPROVED 8 June 49 REVISED 1 31 Aug 51 2 3 Mar 59 3 30 June 1968