

U.S. DEPARTMENT OF COMMERCE
National Technical Information Service

AD-AC36 035

DESIGN AND EVALUATION METHODS FOR OPTIMIZING
EJECTION SEAT CUSHIONS FOR COMFORT AND SAFETY

FROST ENGINEERING DEVELOPMENT CORPORATION
ENGLEWOOD, COLORADO

FEBRUARY 1977

ADA036035

AMRL-TR-68-126

DESIGN AND EVALUATION METHODS FOR OPTIMIZING
EJECTION SEAT CUSHIONS FOR COMFORT AND SAFETY



Frost Engineering Development Corporation
3900 South Kalamath
Englewood, Colorado 80110

①
B. S.

February 1977

Approved for public release; distribution unlimited

AEROSPACE MEDICAL RESEARCH LABORATORY
AEROSPACE MEDICAL DIVISION
AIR FORCE SYSTEMS COMMAND
WRIGHT-PATTERSON AIR FORCE BASE, OHIO

REPRODUCED BY
NATIONAL TECHNICAL
INFORMATION SERVICE
U. S. DEPARTMENT OF COMMERCE
SPRINGFIELD, VA. 22161

DDC
RECEIVED
FEB 24 1977
STVL

SECURITY CLASSIFICATION OF THIS PAGE (When Data Entered)

REPORT DOCUMENTATION PAGE		READ INSTRUCTIONS BEFORE COMPLETING FORM
1. REPORT NUMBER <p style="text-align: center;">AMRL-TR-68-126</p>	2. GOVT ACCESSION NO.	3. RECIPIENT'S CATALOG NUMBER
4. TITLE (and Subtitle) <p style="text-align: center;">DESIGN AND EVALUATION METHODS FOR OPTIMIZING EJECTION SEAT CUSHIONS FOR COMFORT AND SAFETY</p>		5. TYPE OF REPORT & PERIOD COVERED <p style="text-align: center;">Final report (Jul 67-Jun 68)</p>
		6. PERFORMING ORG. REPORT NUMBER <p style="text-align: center;">338-7 ✓</p>
7. AUTHOR(s) <p style="text-align: center;">Ernest L. Stech</p>		8. CONTRACT OR GRANT NUMBER(s) <p style="text-align: center;">F33615-67-C-1912 ✓</p>
9. PERFORMING ORGANIZATION NAME AND ADDRESS <p style="text-align: center;">Frost Engineering Development Corporation ✓ 3900 South Kalamath Englewood, Colorado 80110</p>		10. PROGRAM ELEMENT, PROJECT, TASK AREA & WORK UNIT NUMBERS <p style="text-align: center;">62202F 7231-01-53</p>
11. CONTROLLING OFFICE NAME AND ADDRESS <p style="text-align: center;">Aerospace Medical Research Laboratory, Aerospace Medical Division, Air Force Systems Command, Wright-Patterson Air Force Base, Ohio 45433</p>		12. REPORT DATE <p style="text-align: center;">February 1977</p>
		13. NUMBER OF PAGES <p style="text-align: center;">134</p>
14. MONITORING AGENCY NAME & ADDRESS (if different from Controlling Office)		15. SECURITY CLASS. (of this report) <p style="text-align: center;">UNCLASSIFIED</p>
		15a. DECLASSIFICATION/DOWNGRADING SCHEDULE
16. DISTRIBUTION STATEMENT (of this Report) <p style="text-align: center;">Approved for public release; distribution unlimited</p>		
17. DISTRIBUTION STATEMENT (of the abstract entered in Block 20, if different from Report)		
18. SUPPLEMENTARY NOTES		
19. KEY WORDS (Continue on reverse side if necessary and identify by block number)		
Seat Cushion Comfort Dynamics Comfort Testing Passive Seat Cushion		Inflatable Seat Cushion Ejection Dynamics
20. ABSTRACT (Continue on reverse side if necessary and identify by block number)		
<p>Two kinds of cushions, passive and inflatable, were developed using analytic and empirical optimization procedures to enhance both comfort and safety. Comfort tests were run on a series of polyurethane foams, an inflatable seat cushion, and two operational seat cushions. Load-deflection and damping coefficient data were also obtained. Results of the tests showed that comfort increases as cushion thickness or inflation pressure increases. Analog computer results using a single-degree-of-</p>		

SECURITY CLASSIFICATION OF THIS PAGE(When Data Entered)

Block 20. continued

freedom model of the human body demonstrated an increasing overshoot with increasing thickness or inflation pressure except for low density polyurethane foam. Optimization curves for comfort versus dynamic overshoot were generated and used in the design of the optimized cushions.

i (4)

SECURITY CLASSIFICATION OF THIS PAGE(When Data Entered)

NOTICES

When US Government drawings, specifications, or other data are used for any purpose other than a definitely related Government procurement operation, the Government thereby incurs no responsibility nor any obligation whatsoever, and the fact that the Government may have formulated, furnished, or in any way supplied the said drawings, specifications, or other data, is not to be regarded by implication or otherwise, as in any manner licensing the holder or any other person or corporation, or conveying any rights or permission to manufacture, use, or sell any patented invention that may in any way be related thereto.

Please do not request copies of this report from Aerospace Medical Research Laboratory. Additional copies may be purchased from:

National Technical Information Service
5285 Port Royal Road
Springfield, Virginia 22161

Federal Government agencies and their contractors registered with Defense Documentation Center should direct requests for copies of this report to:

Defense Documentation Center
Cameron Station
Alexandria, Virginia 22314

TECHNICAL REVIEW AND APPROVAL

AMRL-TR-68-126

This report has been reviewed by the Information Office (OI) and is releasable to the National Technical Information Service (NTIS). At NTIS, it will be available to the general public, including foreign nations.

This technical report has been reviewed and is approved for publication.

FOR THE COMMANDER



HENNING E. VON GIERKE
Director
Biodynamics and Bionics Division
Aerospace Medical Research Laboratory

i(b)

SUMMARY

A method for optimizing ejection seat cushions using injury probability and comfort data was developed. The optimization procedure was used to generate an optimal passive cushion consisting of polyurethane foam and an optimal inflatable cushion. In the case of the inflatable cushion, the use of rapid pre-ejection deflation permits maximization of comfort characteristics.

Comfort testing was performed on various cushions together with mechanical load-deflection and damping coefficient tests. In general, increasing the thickness of a seat cushion increases the comfort but also increases the probability of injury. Analog computer studies were used to estimate the injury probability levels from the load-deflection data.

The research and development program showed that comfort testing is a practical tool in seat cushion design. Existing procedures for mechanical testing and dynamic analysis are adequate for cushion optimization but further development is needed to obtain more accurate injury probability levels. There is a need for further research on the physical significance of the optimization strategy, particularly over a wide range of input acceleration conditions.

FOREWORD

This investigation was initiated by the Vibration and Impact Branch, Biodynamics and Bionics Division, Aerospace Medical Research Laboratory, Wright-Patterson Air Force Base, Ohio. The research was conducted by Frost Engineering Development Corporation of Englewood, Colorado, with the dynamic analyses of cushions conducted by the Payne Division, Wyle Laboratories, Rockville, Maryland. The co-principal investigators were Mr. Ernest L. Stech of Frost Engineering and Mr. Peter R. Payne of Wyle Laboratories. Captain Kenneth C. Flagg, Jr., of the Vibration and Impact Branch, was the contract monitor for Aerospace Medical Research Laboratory. The research was performed under Contract No. F33615-67-C-1912 and in support of Project 7231, "Biomechanics of Aerospace Operations", Task 723101, "Effects of Vibration and Impact", and Work Unit No. 723101053; beginning in July 1967 and ending in June 1968.

Preceding page blank

TABLE OF CONTENTS

<u>SECTION</u>		<u>PAGE</u>
I	INTRODUCTION	1
	PROGRAM DEFINITION	1
	PREVIOUS RESEARCH AND DEVELOPMENT IN SEAT CUSHION DYNAMIC RESPONSE	2
	RESEARCH ON SEATING COMFORT	3
	VIBRATION ISOLATION CHARACTERISTICS OF SEAT CUSHIONS	6
II	OPTIMIZATION PROCEDURES FOR EJECTION SEAT CUSHIONS	8
	FACTORS AFFECTING OPTIMIZATION	8
	OPTIMIZATION CRITERIA FOR THE PRESENT PROGRAM	19
I'I	TEST OF TWO OPERATIONAL AIR FORCE SEAT CUSHIONS	20
	IDENTIFICATION OF THE SAMPLES	20
	STATIC LOAD-DEFLECTION TESTS	20
	DYNAMIC REBOUND TESTS	29
	COMFORT TESTS	29
	DYNAMIC RESPONSE ANALYSIS	35
	CONCLUSIONS ON THE OPERATIONAL AIR FORCE SEAT CUSHIONS	35
IV	DEVELOPMENT OF AN OPTIMUM PASSIVE CUSHION	36
	DISCUSSION	36
	POLYURETHANE FOAM COMFORT TESTS	36
	STATIC LOAD-DEFLECTION TESTS	46
	REBOUND RES .ENCE TESTS	46
	OPTIMIZATION OF THE PASSIVE CUSHION	46
	DESIGN OF THE OPTIMUM PASSIVE CUSHION	57

TABLE OF CONTENTS
(CONT.)

<u>SECTION</u>		<u>PAGE</u>
V	DEVELOPMENT OF AN INFLATABLE CUSHION	59
	DISCUSSION	59
	PRELIMINARY DEVELOPMENT TESTS	59
	COMFORT TESTS OF THE INFLATABLE CUSHION	60
	STATIC LOAD-DEFLECTION TESTS OF THE INFLATABLE CUSHION	74
	INFLATION/DEFLATION UNIT DEVELOPMENT AND TEST	74
	OPTIMIZATION OF THE INFLATABLE SEAT CUSHION	75
VI	CONCLUSIONS AND RECOMMENDATIONS	82
	CONCLUSIONS AND RECOMMENDATIONS ON OPTIMIZATION METHOD	82
	CONCLUSIONS AND RECOMMENDATIONS ON MECHANICAL TESTING	82
	CONCLUSIONS AND RECOMMENDATIONS ON COMFORT TESTING	83
	CONCLUSIONS AND RECOMMENDATIONS ON DYNAMIC ANALYSIS	83
	CONCLUSIONS AND RECOMMENDATIONS ON PASSIVE AND INFLATABLE CUSHION OPTIMIZATION	84
APPENDIX A	ANALOG RESULTS OF ACCELERATION INPUTS TO A SIMPLE MAN MODEL IN SERIES WITH 19 DIFFERENT CUSHION MODELS	86
	INTRODUCTION	87
	GENERAL THEORY	87
	TEST RESULTS AND CONCLUSIONS	89
APPENDIX B	TEST PROCEDURES	96
	LOAD-DEFLECTION TESTS	97
	DYNAMIC REBOUND TESTS	99
	TURBIDITY PRESSURE MEASUREMENTS	101
	COMFORT TESTS	106

LIST OF FIGURES

<u>Number</u>	<u>Title</u>	<u>Page</u>
1	THE EFFECT OF SEAT CUSHION THICKNESS ON HIP ACCELERATION FROM BONDURANT (2)	2
2	CONFIGURATION OF THE AMRL 1950's INFLATABLE SEAT CUSHION - NOT DRAWN TO SCALE	4
3	PRESSURE DISTRIBUTIONS ON HARD SURFACE AND ON THE DEMPSEY-HERTZBERG DYNAMIC CUSHION	5
4	HYPOTHESIZED RELATIONSHIP OF SEAT CUSHION STIFFNESS AND THICKNESS TO COMFORT	9
5	APPROXIMATE COMFORT VERSUS STIFFNESS USING DATA FROM THE STUDY BY SLECHTA ET. AL.	10
6	VIBRATION ISOLATION CHARACTERISTICS OF TYPICAL SEAT CUSHIONS	11
7	PROBABILITY OF DAMAGE TO VERTEBRA L1	12
8	DATA ADAPTED FROM BONDURANT (2) SEAT CUSHION TESTS SHOWING ATTENUATION AND AMPLIFICATION	13
9	THE RELATIONSHIP OF INJURY PROBABILITY TO CUSHION THICKNESS FOR A LATEX CUSHION	14
10	AN EXAMPLE OF SUBJECTIVE COMFORT ESTIMATES EXPRESSED AS A PROBABILITY REFERRED TO A NO-CUSHION CONDITION	16
11	AN EXAMPLE OF OPTIMIZATION USING ENDPLATE FRACTURE DATA FROM FIGURE 9 AND COMFORT DATA FROM FIGURE 10	17
12	AN EXAMPLE OF OPTIMIZATION USING COMPRESSION FRACTURE DATA FROM FIGURE 9 AND ACTUAL COMFORT TEST RESULTS	18
13	TRANSIENT ACCELERATION INPUT	19
14	LATEX FOAM F101 EJECTION SEAT CUSHION	22
15	POLYURETHANE F104 EJECTION SEAT CUSHION	22
16	MIL-S-27332A (USAF) LOAD-DEFLECTION VALUES FOR THE F101 EJECTION SEAT CUSHION	23

LIST OF FIGURES (CONT.)

<u>Number</u>	<u>Title</u>	<u>Page</u>
17	MIL-S-27332A (USAF) LOAD-DEFLECTION VALUES FOR THE F104 EJECTION SEAT CUSHION	24
18	HUMAN BUTTOCK INDENTATION WITH LEGS EXTENDED AND LEGS TUCKED FOR THE F101 EJECTION SEAT CUSHION	25
19	HUMAN BUTTOCK INDENTATION WITH LEGS EXTENDED AND LEGS TUCKED FOR THE F104 EJECTION SEAT CUSHION	26
20	HUMAN BUTTOCK INDENTATION WITH LEGS EXTENDED AND VARYING APPLIED LOADS FOR THE F101 EJECTION SEAT CUSHION	27
21	HUMAN BUTTOCK INDENTATION WITH LEGS EXTENDED AND VARYING APPLIED LOADS FOR THE F104 EJECTION SEAT CUSHION	28
22	CRITICAL DAMPING RATIO FOR TWO OPERATIONAL SEAT CUSHIONS	30
23	AVERAGE HOURLY COMFORT RATING FOR TWO AIR FORCE OPERATIONAL SEAT CUSHIONS	32
24	AVERAGE HOURLY BUTTOCK DISCOMFORT FOR TWO OPERATIONAL AIR FORCE SEAT CUSHIONS	33
25	THE NUMBER OF HOURS SUBJECTS ESTIMATED THEY COULD CONTINUE TO SIT FOR TWO AIR FORCE OPERATIONAL SEAT CUSHIONS	34
26	AVERAGE HOURLY COMFORT RATINGS FOR SIX THICKNESSES OF 1.6 LB/FT ³ POLYURETHANE FOAM	40
27	THE NUMBER OF HOURS SUBJECTS ESTIMATED THEY COULD CONTINUE TO SIT FOR FOUR THICKNESSES OF 1.6 LB/FT ³ POLYURETHANE FOAM	40
28	THE NUMBER OF HOURS SUBJECTS ESTIMATED THEY COULD CONTINUE TO SIT FOR TWO THICKNESSES OF 1.6 LB/FT ³ POLYURETHANE FOAM	41
29	AVERAGE HOURLY BUTTOCK DISCOMFORT FOR SIX THICKNESSES OF 1.6 LB/FT ³ POLYURETHANE FOAM	42
30	TUBEROSITY PRESSURE AS A FUNCTION OF CUSHION THICKNESS FOR 1.6 LB/FT ³ POLYURETHANE FOAM	43

LIST OF FIGURES (CONT.)

<u>Number</u>	<u>Title</u>	<u>Page</u>
31	AVERAGE HOURLY COMFORT RATING AS A FUNCTION OF CUSHION THICKNESS FOR 1.6 LB/FT ³ POLYURETHANE FOAM	43
32	NUMBER OF HOURS SUBJECTS ESTIMATED THEY COULD CONTINUE TO SIT AS A FUNCTION OF THICKNESS FOR 1.6 LB/FT ³ POLYURETHANE FOAM	44
33	BUTTOCK DISCOMFORT FOR SIX THICKNESSES OF 1.6 LB/FT ³ POLYURETHANE FOAM	44
34	THE POST-TEST COMFORT RATING OF THE SEAT FOR SIX THICKNESSES OF 1.6 LB/FT ³ POLYURETHANE FOAM	45
35	LOAD-DEFLECTION CURVES FOR ENSOLITE WITH NO POLYURETHANE FOAM	49
36	LOAD-DEFLECTION CURVES FOR ENSOLITE WITH 1/2-INCH OF POLYURETHANE FOAM	50
37	LOAD-DEFLECTION CURVES FOR ENSOLITE WITH 1-INCH OF POLYURETHANE FOAM	51
38	CRITICAL DAMPING RATIO VALUES FOR 1-INCH THICK 1.6 LB/FT ³ POLYURETHANE FOAM	52
39	ANALOG COMPUTER RESULTS	52
40	INJURY RISK (COMPRESSION FRACTURE ONLY) FOR THE PASSIVE CUSHION CONFIGURATION TESTED	53
41	OPTIMIZATION CURVE OF A 1/4-INCH ENSOLITE CUSHION WITH POLYURETHANE FOAM	54
42	DOUBLE MASS MODEL OF THE HUMAN BODY ON A SEAT CUSHION	55
43	HYPOTHETICAL OPTIMIZATION SITUATION ILLUSTRATING NO TRUE OPTIMUM	56
44	OPTIMUM PASSIVE CUSHION - GENERAL ARRANGEMENT	58
45	NON-EXTENSIBLE 2-INCH SIDEWALL INFLATABLE CUSHION	63
46	EXTENSIBLE INFLATABLE CUSHION	64
47	INFLATABLE CUSHION CONFIGURATION DEVELOPMENT TESTING	65

LIST OF FIGURES (CONT.)

<u>Number</u>	<u>Title</u>	<u>Page</u>
48	AVERAGE HOURLY COMFORT RATING FOR FOUR INFLATION PRESSURES FOR AN INFLATABLE SEAT CUSHION	65
49	NUMBER OF HOURS SUBJECTS ESTIMATED THEY COULD CONTINUE TO SIT FOR FOUR INFLATION PRESSURES FOR AN INFLATABLE SEAT CUSHION	66
50	AVERAGE HOURLY BUTTOCK DISCOMFORT FOR FOUR INFLATION PRESSURES FOR AN INFLATABLE SEAT CUSHION	67
51	AVERAGE COMFORT RATING AS A FUNCTION OF CUSHION INFLATION PRESSURE FOR AN INFLATABLE SEAT CUSHION	68
52	NUMBER OF HOURS SUBJECTS ESTIMATED THEY COULD CONTINUE TO SIT AS A FUNCTION OF CUSHION INFLATION PRESSURE FOR AN INFLATABLE SEAT CUSHION	68
53	AVERAGE BUTTOCK DISCOMFORT FOR FOUR INFLATION PRESSURES FOR AN INFLATABLE SEAT CUSHION	69
54	POST-TEST COMFORT RATING FOR FOUR INFLATION PRESSURES FOR AN INFLATABLE SEAT CUSHION	69
55	RESULTS OF TESTS CONDUCTED WITH DOUBLE ELLIPSOID INDENTOR FOOT (MODIFIED F4C CUSHION)	76
56	PNEUMATIC AND ELECTRONIC SCHEMATIC OF INFLATION CONTROL UNIT	77
57	SCHEMATIC, ACTIVE CUSHION PNEUMATIC CONTROL	78
58	DEFLATION TIME FOR VARIOUS ORIFICE AREAS FOR AN INFLATABLE CUSHION	79
59	RATE OF TUBEROSITY PRESSURE INCREASE FOR AN INFLATABLE CUSHION	80
60	OPTIMIZATION CURVE OF A 1/4-INCH ENSOLITE INFLATABLE CUSHION WITH POLYURETHANE FOAM	81
61	THE DYNAMIC MAN MODEL PLUS SEAT CUSHION	87
62	ANALOG FOR ANALYZING ACCELERATION INPUTS INTO A SIMPLE MAN AND CUSHION MODELS	88
63	OPERATIONAL ACCELERATION INPUT	89

LIST OF FIGURES (CONT.)

<u>Number</u>	<u>Title</u>	<u>Page</u>
64	LOAD-DEFLECTION CURVES FOR CUSHIONS 1, 2, 3, AND 4 (CONSISTING OF 1/4, 1/2, 3/4, AND 1-INCH ENSOLITE)	90
65	LOAD-DEFLECTION CURVES FOR CUSHIONS 5, 6, 7, AND 8 (CONSISTING OF 1/4, 1/2, 3/4, AND 1-INCH ENSOLITE PLUS 1-INCH OF 1.6 LB/FT ³ POLYURETHANE FOAM)	91
66	LOAD-DEFLECTION CURVES FOR CUSHIONS 9, 10, 11, AND 12 (CONSISTING OF 1/4, 1/2, 3/4, AND 1-INCH ENSOLITE PLUS 2-INCHES OF 1.6 LB/FT ³ POLYURETHANE FOAM)	92
67	LOAD-DEFLECTION CURVE FOR CUSHION 13, AIR FORCE OPERATIONAL F104 EJECTION SEAT CUSHION	93
68	LOAD-DEFLECTION CURVE FOR CUSHION 14, AIR FORCE OPERATIONAL F101 EJECTION SEAT CUSHION	94
69	THE DYNAMIC MASS MODEL WITH THE LOWER PELVIC MASS INCLUDED PLUS SEAT CUSHION	95
70	STATIC TEST RIG USED TO OBTAIN LOAD-DEFLECTION CURVES	97
71	INDENTOR FEET USED IN STATIC TESTS OF SEAT CUSHION	98
72	IMPACT PENDULUM USED IN DYNAMIC REBOUND TESTS	100
73	MECHANICAL AND ELECTRICAL CONFIGURATION OF THE TUBEROSITY PRESSURE TRANSDUCER	101
74	ISCHIAL TUBEROSITY CAPACITANCE PRESSURE TRANSDUCER MOUNTED ON A TEST SEAT	102
75	DIODE BRIDGE CONFIGURATION USED IN SENSING CAPACITANCE CHANGES	103
76	PORTION OF CALIBRATION CURVE FOR TUBEROSITY PRESSURE TRANSDUCERS	104
77	TUBEROSITY TRANSDUCER, CAPACITANCE BRIDGE UNIT, AND UTVM READ-OUT AS USED WITH THE TEST SEAT	105
78	COMFORT TEST SEAT	108

LIST OF TABLES

<u>Number</u>	<u>Title</u>	<u>Page</u>
I	STATISTICAL SIGNIFICANCE OF THE DIFFERENCES BETWEEN TWO AIR FORCE OPERATIONAL SEAT CUSHIONS	31
II	PHYSICAL CHARACTERISTICS OF THE 1.6 LB/FT ³ POLYURETHANE FOAM USED IN COMFORT TESTS	38
III	THE STATISTICAL SIGNIFICANCE OF THE DIFFERENCE IN OVERALL COMFORT RATING FOR SIX THICKNESSES OF 1.6 LB/FT ³ POLYURETHANE FOAM	38
IV	THE STATISTICAL SIGNIFICANCE OF THE DIFFERENCE IN NUMBER OF HOURS SUBJECTS ESTIMATED THEY COULD CONTINUE TO SIT FOR FOUR THICKNESSES OF 1.6 LB/FT ³ POLYURETHANE FOAM	39
V	THE STATISTICAL SIGNIFICANCE OF THE DIFFERENCE IN BUTTOCK DISCOMFORT FOR SIX THICKNESSES OF 1.6 LB/FT ³ POLYURETHANE FOAM	39
VI	THE STATISTICAL SIGNIFICANCE OF THE DIFFERENCE IN POST-TEST FINAL RATING FOR SIX THICKNESSES OF 1.6 LB/FT ³ POLYURETHANE FOAM	39
VII	A COMPARISON OF SUBJECT PANELS FOR THE INFLATABLE AND PASSIVE CUSHIONS FOR THE ZERO-THICKNESS CUSHION	70
VIII	FREQUENCY OF COMPLAINTS DURING HOURLY EVALUATIONS OF SEAT CUSHIONS	70
IX	THE STATISTICAL SIGNIFICANCE OF THE DIFFERENCE IN OVERALL COMFORT RATING FOR FOUR INFLATION PRESSURES FOR AN INFLATABLE CUSHION	71
X	THE STATISTICAL SIGNIFICANCE OF THE DIFFERENCE IN NUMBER OF HOURS SUBJECTS ESTIMATED THEY COULD CONTINUE TO SIT FOR FOUR INFLATION PRESSURES FOR AN INFLATABLE CUSHION	71
XI	THE STATISTICAL SIGNIFICANCE OF THE DIFFERENCE IN BUTTOCK DISCOMFORT FOR FOUR INFLATION PRESSURES FOR AN INFLATABLE CUSHION	72
XII	THE STATISTICAL SIGNIFICANCE OF THE DIFFERENCE IN POST-TEST FINAL RATING FOR FOUR INFLATION PRESSURES FOR AN INFLATABLE CUSHION	72

LIST OF TABLES (CONT.)

<u>Number</u>	<u>Title</u>	<u>Page</u>
XIII	A COMPARISON OF INFLATABLE CUSHION RATINGS AT 50 mm Hg INFLATION PRESSURE TO A 2-INCH CUSHION OF 1.6 LB/FT ³ POLYURETHANE	73
XIV	A COMPARISON OF THE INFLATABLE CUSHION TO THE F104 AND F101 CUSHIONS	73

SECTION I

INTRODUCTION

PROGRAM DEFINITION

As aircraft mission durations increase, the problem of comfort assumes importance in determining operational effectiveness. Missions last from one to eight hours or more, particularly with inflight refueling. Simultaneous with the need for comfort, there exists a requirement to provide ejection capabilities from zero altitude and zero speed up to high altitudes and supersonic speeds. In order to achieve parachute opening at low altitudes and speeds and also to obtain tail clearance at high speeds, the ejection seat must accelerate rapidly, but without damaging the occupant. Seat cushions can increase the hazard of ejection by providing undesirable resiliencies between the pilot and the seat.

Added to the comfort and safety requirements is the need to minimize discomfort and pilot performance degradation due to inflight vibrations. The ideal seat cushion should serve as a vibration isolator among its other functions.

A program was conducted to study the optimization of seat cushions for both comfort and safety. One portion of the study constrained the optimization process to a passive system, while the other portion allowed consideration of active systems. The historical background, optimization techniques, test methods, and development results are presented in subsequent sections.

For the purpose of this report, seat cushions are divided into two separate classes as follows:

PASSIVE

A conventional-type seat cushion that consists of a foam insert and a cloth cover.

INFLATABLE

A conventional-type seat cushion plus an inflatable section with a manual or automatic means for inflate/deflate. During normal flight the cushion is inflated to the most comfortable level for the individual.

A third type of cushion is feasible, the active cushion that vibrates or pulsates at a rate of one cycle every five seconds or more. Since the inflatable cushion developed in this program can be automatically inflated and deflated only for thirty seconds or longer periods, it is not a truly active cushion, but more properly a cycling inflatable cushion. Therefore, the terminology "passive" and "inflatable" is used exclusively in this report.

PREVIOUS RESEARCH AND DEVELOPMENT IN SEAT CUSHION DYNAMIC RESPONSE

The two earliest studies of the effect of cushions on ejection seat safety were performed by Latham (1) and Bondurant (2). In both reports, the effect of the seat cushion on acceleration loads was demonstrated. Figure 1 shows test data analyzed by Bondurant to show a relationship between acceleration measured on the subject and the thickness of a specific type of seat cushion.

Latham concluded in his discussion that "It is apparent that the part played by the seat cushion or pack is of major significance. A soft upper surface is required to achieve spreading of the load over a wide area of the body, yet at the same time full compression of the pack should be approached with the normal weight of the pilot (180 to 200 lbs.). A slow responding foam plastic material 2 to 2-1/2" thick is very suitable as a seat cushion for this purpose. In addition, the compressibility of the remainder of the seat pack should be reduced to a minimum" Latham recognized the need to achieve virtually full compression of the cushion under normal 1-g loads, a factor to which reference is made later in the present study.

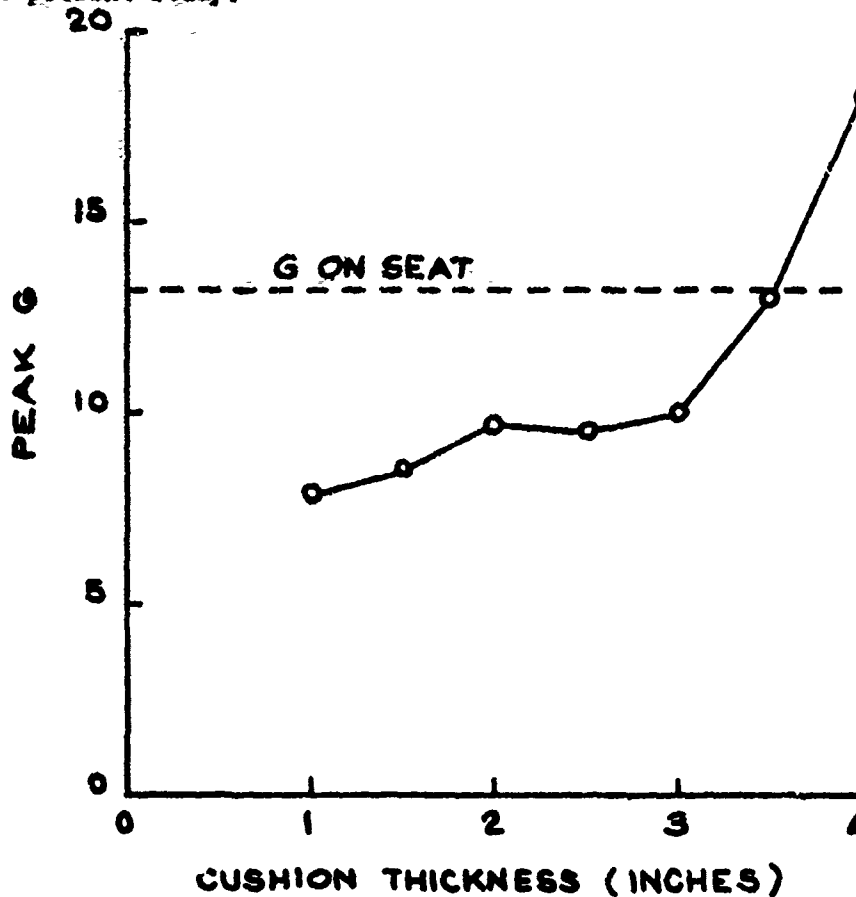

FIGURE 1
THE EFFECT OF SEAT CUSHION THICKNESS
ON HIP ACCELERATION FROM BONDURANT (2)

Bondurant summarized his findings as follows: "1. Ejection seat cushions of low compression resistance and/or great thickness may significantly magnify the force acting on the seat occupant during headward acceleration. 2. During any specific headward acceleration, this magnification of force increases the likelihood of injury, e.g., compression fracture of a vertebra. 3. The standard MC-1 and MC-2 cushions (medium density foam rubber) are not thick enough to constitute such a hazard. The limited standard A-5 cushion may magnify the force acting on the subject during headward acceleration. 4. The best available cushions are made of plastic, with a compression resistance high enough to safely permit a thickness adequate for comfort." The assertions on acceleration amplification made by Latham and Bondurant indicate the undesirable safety features of soft, thick cushions.

Cadaver tests were conducted by Hodgson, Lissner, and Patrick (3) to determine, among other things, the effect of cushions on observed spinal loads. They found an increase in the ratio of peak to mean response for all types of cushions tested when compared to a no-cushion condition.

In 1959, an Air Force technical report dealing with new materials for seat and back cushions was published (4). Urethane foams were recommended as seat cushion materials as a result of the reported developments. Meanwhile, the Royal Air Force was also investigating the properties of polyurethane foam (5). Both the U. S. and British reports dealt with static load-deflection data and dynamic damping data.

In the late 1950's and early 1960's, more attention was focused on the dynamics of the human body. Goldman and von Gierke (6) summarized the available information in a review of the area. Subsequently, Payne (7) developed a sophisticated theory of personnel support system dynamics. Payne's results permitted at least rough estimates of the effect of seat cushion dynamics on the response of the human body to acceleration input. During the present program, Payne performed additional work on the analysis of seat cushion dynamics, the results being discussed subsequently (8).

RESEARCH ON SEATING COMFORT

Comfort has been a major problem in seat design for as long as man has used seats. There is an intuitive notion among seat designers and seat cushion designers that softness is related to comfort and that it is effective primarily because it spreads the load across the buttocks. Latham (1) for example, says "a soft upper surface is required to achieve spreading of the load over a wide area of the body"
Bondurant (2) makes the following suggestion on cushion optimization, "the best available cushions are made of plastic, with a compression resistance high enough safely to permit a thickness adequate for comfort".

However, automobile seat designers were interested in evaluating riding comfort and proposed specific criteria as early as 1935 (9). In Sweden, Akerblom published a monograph (10) on the standing and sitting

posture as related to chair design, and he discussed the principles of comfortable seating and their application in the design of comfortable seats. Commercial aircraft designers were also concerned with seating comfort, Cumberland and Bowey (11) published a paper on passenger seat comfort in 1950. Dreyfuss (12) summarized the principles of comfortable seat design in 1960. His main points were the provision of a large seat pan, seat back tilt, and a hip angle of 90° or more. Where possible, a seat should include the possibility of sitting in several positions since some discomfort arises out of immobility. For the bottom cushion, Dreyfuss feels the body weight should be supported on the tuberosities of the pelvis.

Active attempts at improving seating comfort through contouring were made by Hertzberg in the late 1940's (13, 14). Pulsating seat cushions were studied as comfort enhancement devices by Hertzberg as reported in 1956 (15) and 1958 (16). In 1962, Dempsey described in more detail development of an inflatable seat cushion for long duration flights (17). The configuration of the cushion is shown in Figure 2. It consisted of a foam cushion with two inflatable areas underneath the occupant's tuberosities, the pressure distribution being varied in this way. The change in tuberosity pressure with the cushion inflated and deflated is shown in Figure 3. Dempsey reports a 20 second inflation and 20 second deflation cycle used on this seat. It was flown in a B47 which incorporated a variable geometry ejection seat. Total mission duration of the B47 flight was 80 hours and the results of this flight were reported by van Wart in 1961 (18).

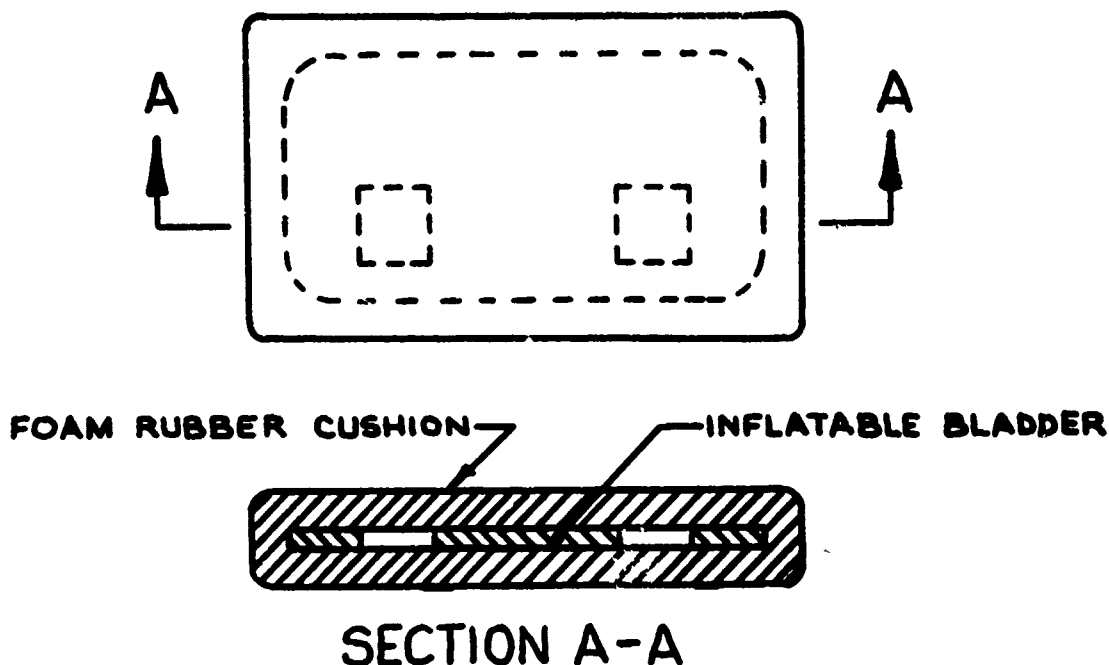

FIGURE 2
 CONFIGURATION OF THE AMRL 1950's INFLATABLE
 SEAT CUSHION - NOT DRAWN TO SCALE

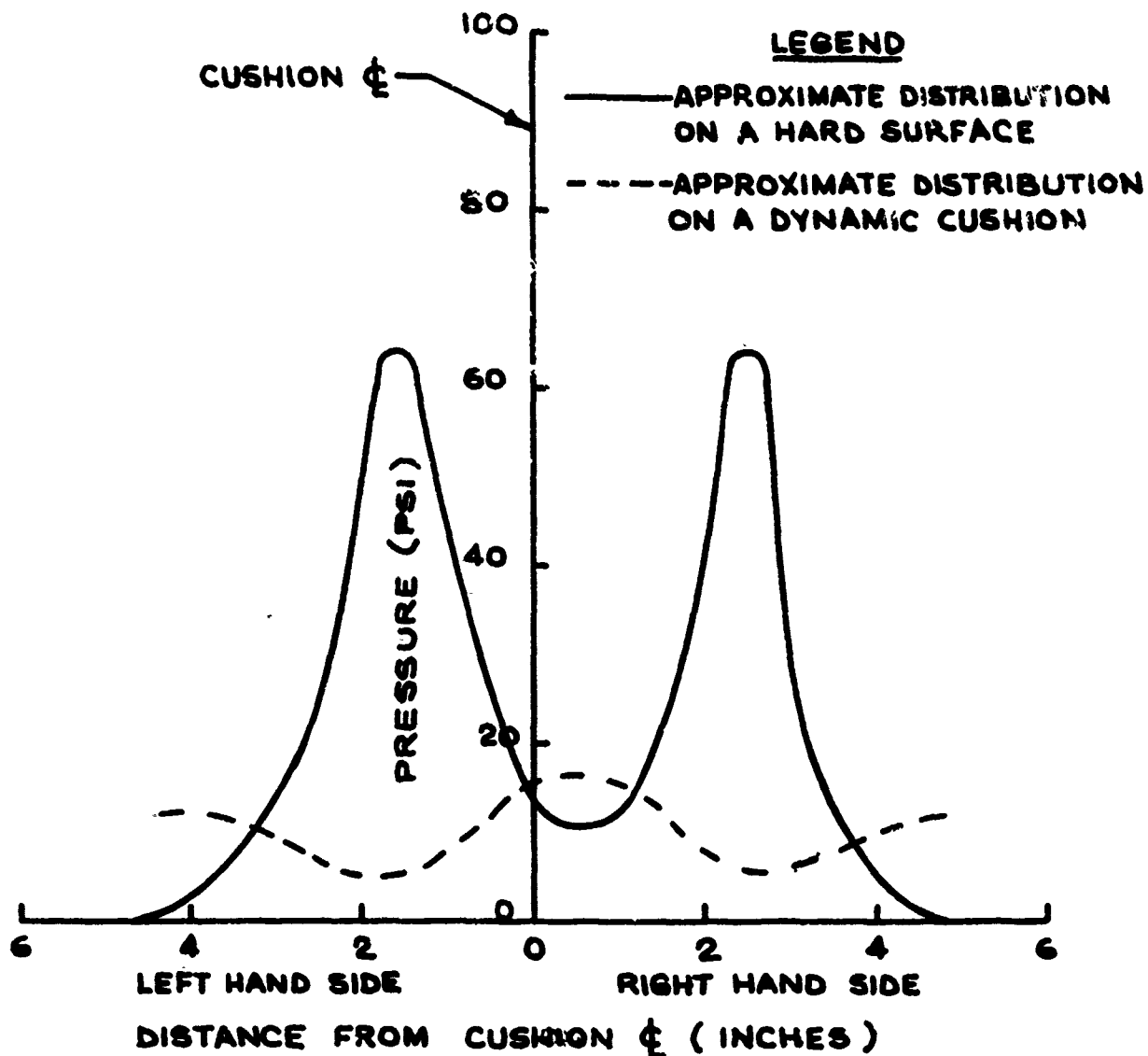

FIGURE 3
 PRESSURE DISTRIBUTIONS ON HARD SURFACE
 AND ON THE DEMPSEY-HERTZBERG DYNAMIC CUSHION

The principle of pulsating pressures had been studied as early as 1947 by Henry (19) who checked the use of the anti-g suit to aid in the relief of pilot discomfort. His findings seemed to indicate that g-suit pulsation aided venous blood return.

Some studies have been conducted on the effect of immobility, for example Christensen (20), Gerd (21), and Gervais and Konecci (22). The research concentrated on circulatory factors, and Christensen felt that relieving seating pressure on the soft part of the thighs could help to some extent.

Hertzberg (15) and Dempsey (17) reported attempts at direct measurement of the pressures applied by the buttocks to the seat cushion or seat pan. Kohara, a Japanese investigator discussed the problems of seating comfort and the measurement of buttock/seat loads in an unpublished report in 1965 (23) and subsequently in a magazine article in 1966 (24). Kohara was able to measure pressures by means of chemical contact as well as with electrical instrumentation. Hertzberg and Dempsey utilized a sheet of rubber pressed against a thick piece of plastic with a special lighting arrangement to obtain pressure gradient data.

Hertzberg obtained subjective evaluations in some of his early work (16), but the major attempt at the subjective evaluation of aircraft seating was accomplished by Slechta and his colleagues at Tufts University in 1957 (25). This study involved the comparative evaluation of 7 seats in a carefully conceived and executed experimental program. Unfortunately, Slechta and his fellow investigators did not obtain mechanical buttock/cushion interface data or tuberosity pressure data. Thus, no physical information existed against which the comfort evaluations could be analyzed.

Wachsler and Learner (26) re-analyzed the Slechta data using correlational and factor analysis techniques. Among other findings, the re-analysis showed that buttock discomfort was the major determinant in overall seat comfort ratings. The remainder of the Wachsler and Learner results are discussed subsequently in this report.

On the basis of the previous research conducted in seating comfort, the present program was oriented toward the collection of subjective comfort judgments and simultaneous physical measurements in an effort to relate the two. The methods involved and the results are reported in subsequent sections.

VIBRATION ISOLATION CHARACTERISTICS OF SEAT CUSHIONS

Road vehicle designers use seat design to minimize the effects of vibration on drivers and passengers. Goldman and von Gierke (6) reviewed and summarized the information on road vehicle seating. Most road vehicle seats consist of two major mechanical deflection segments. There is usually a layer of material directly in contact with the person's buttocks that serves as a load distribution technique. This upper surface is then supported by springs that serve as vibration isolators. Engelhardt et. al. (27) have published data that indicates the actual frequency of seats in at least some automobiles is in the vicinity of three cycles per second. Previous research has shown a major fundamental frequency of the human body in the vicinity of six cycles per second, so that a 3-cps seat frequency would provide reasonable attenuation.

Tractor seat design has also been studied intensively in terms of vibration isolation. Kohara has also studied the vibration isolation requirements in high speed trains (23, 24). However, the seat cushion has been used only rarely in military aircraft as a vibration isolater. Severe aircraft vibration problems are usually tackled through gust alleviation schemes and more recently by vibration isolation techniques (28).

SECTION II

OPTIMIZATION PROCEDURES FOR EJECTION SEAT CUSHIONS

FACTORS AFFECTING OPTIMIZATION

As pointed out previously, a seat cushion is primarily a comfort enhancement device with a possible auxiliary function of providing vibration isolation. However, a poor cushion results in excessive dynamic overshoot during ejection. Optimization must balance comfort against risk.

Three hypotheses, based on earlier published research on cushions, were advanced to form a preliminary definition of the problem as follows:

- (1) Increasing the thickness of a cushion will increase its comfort value.
- (2) Increasing the thickness and/or decreasing the stiffness may or may not increase its vibration isolation effectiveness.
- (3) Increasing the thickness will increase the probability of injury during ejection.

These statements were based upon the assumption of a cushion with linear load-deflection characteristics and linear damping. In reality, most cushions are nonlinear in elastic and damped response. Therefore, tests and analytic procedures had to be used to find how close the hypotheses on comfort, isolation, and risk were to reality, and the tests and procedures had to be based on the best available data and theory.

Comfort

A hypothetical relationship of comfort to cushion stiffness, shown in Figure 4, was generated based upon the opinions and limited test results found in the relevant research articles. The line of reasoning used in generating the hypothesis explains the shape of the curves in Figure 4. If a cushion material has a very low stiffness, it does not support the occupant, and the seating situation is equivalent to no cushion at all. At the other extreme, a cushion with very high stiffness supports the occupant away from the rigid seat pan but is in itself as stiff as the seat pan. Between these two extremes, a maximum comfort point exists, being a function of both stiffness and thickness.

The hypothesized relationship was supported, in part, by the results of Slechta's work (25) on seating comfort. A graph of Slechta's data is presented in Figure 5. Since no stiffness data was provided directly and the thickness measurements were hard to interpret, Figure 5 represents a very crude evaluation of comfort versus stiffness.

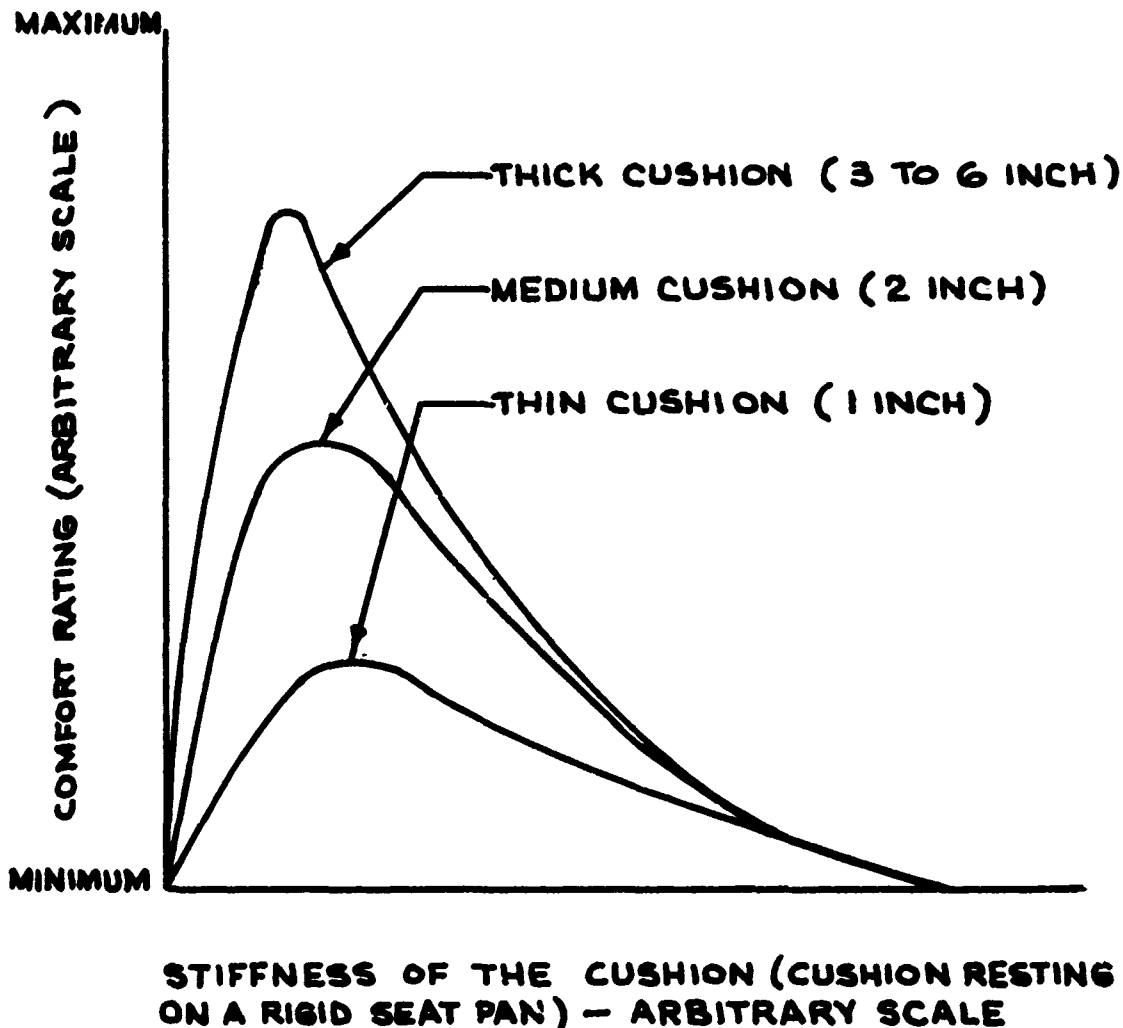

FIGURE 4
HYPOTHESIZED RELATIONSHIP OF SEAT CUSHION
STIFFNESS AND THICKNESS TO COMFORT

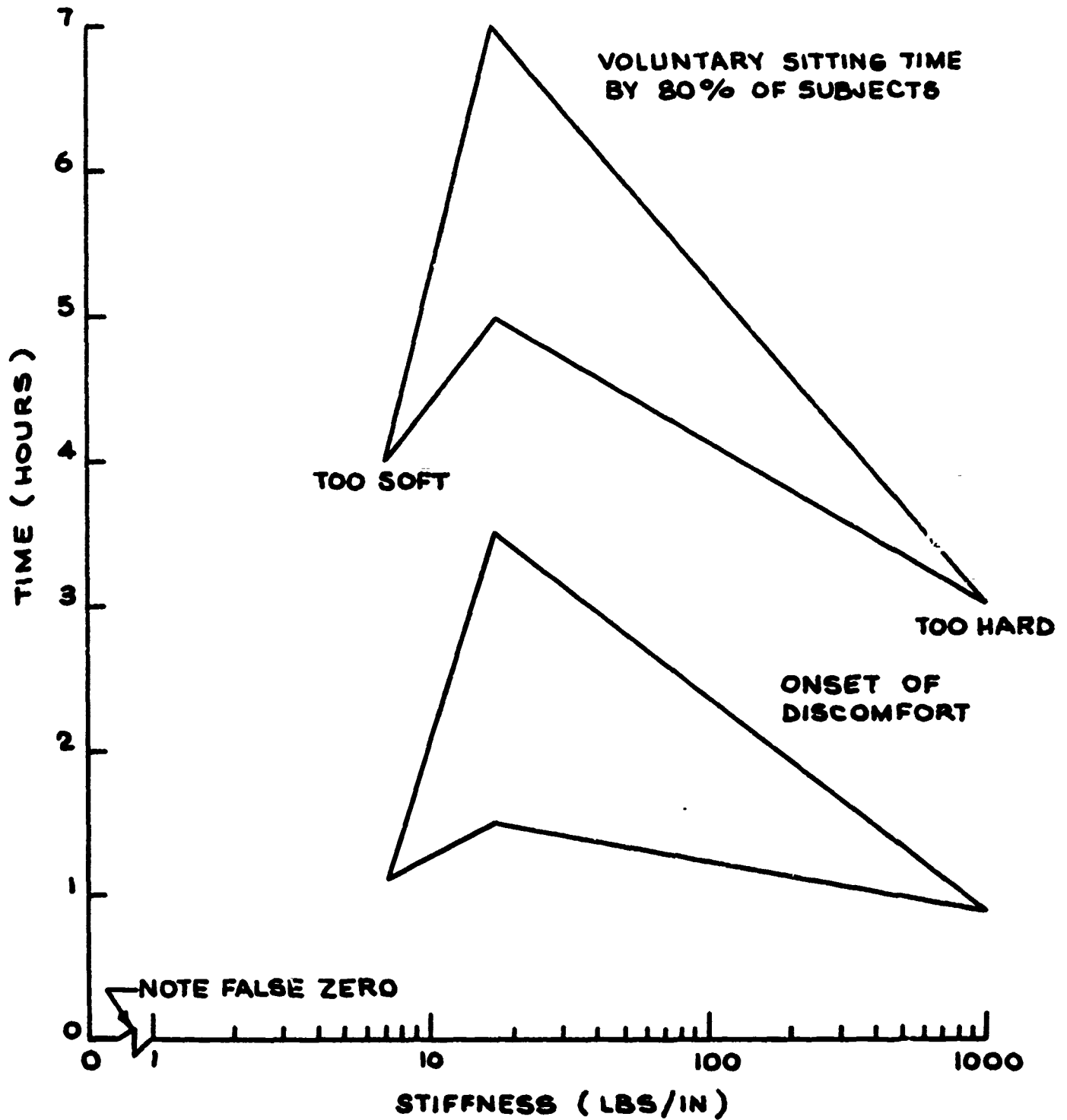

FIGURE 5
APPROXIMATE COMFORT VERSUS STIFFNESS
USING DATA FROM THE STUDY BY SLECHTA ET. AL.

Vibration

To act as a vibration isolator, the seat cushion must have a resonant frequency below that of the system to be isolated. Previous research (30, 31) has shown the upper body of the human being to have a natural frequency of 6 to 8 cps. Therefore, the cushion should have a natural frequency of less than 6 cps. with a man sitting on it.

A linear spring deflected to a value, X_{st} , under one g by a mass, m , has a natural frequency (29) found from

$$f_n = \sqrt{\frac{9.80}{X_{st}}} \quad (1)$$

f_n = natural frequency, cps
 X_{st} = static deflection, inches

The curve for this equation is plotted in Figure 6 together with the zone of human body resonance and the approximate maximum thickness range of current operational seat cushions. This graph shows the limited amount of vibration isolation available from a reasonable cushion thickness.

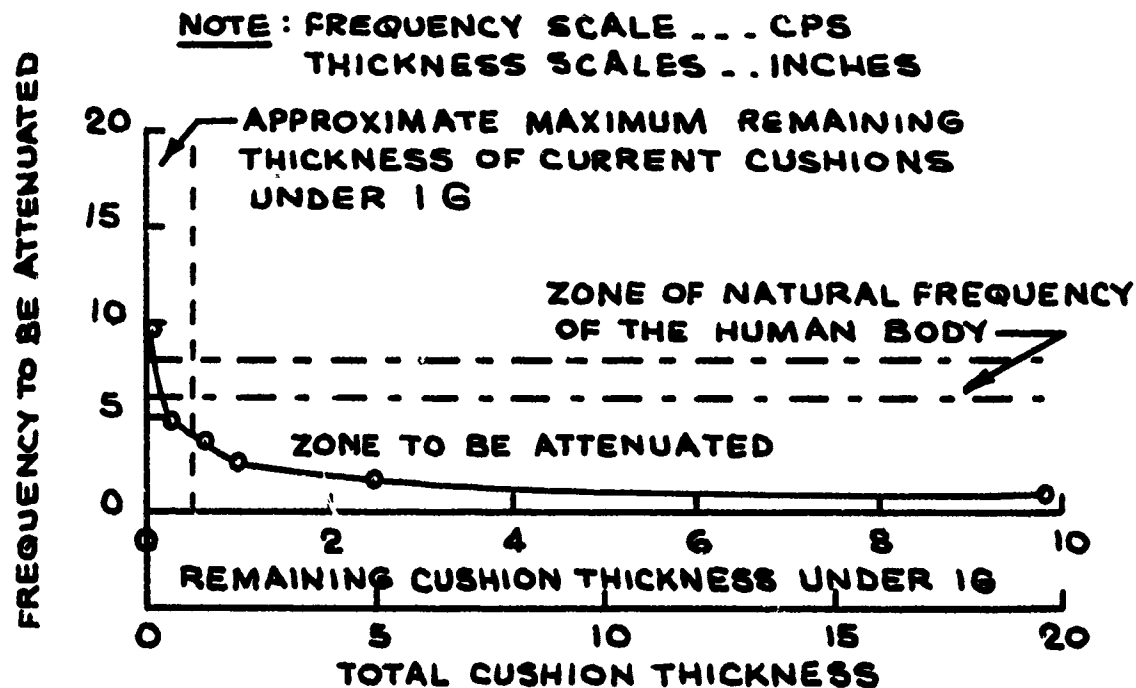

FIGURE 6
 VIBRATION ISOLATION CHARACTERISTICS
 OF TYPICAL SEAT CUSHIONS

Another consideration is important. Cushion bottoming is undesirable from an injury risk standpoint (7). Clearly a large stroke, soft cushion will bottom out under sustained ejection loads. Any attenuation of vibratory inputs below 6 cps. will result in a higher injury probability than a stiffer, thinner cushion. For this reason plus the practical limit on cushion thickness, the use of a seat cushion as a vibration isolator should be limited to the attenuation of frequencies of 10 cps. or higher.

Injury Probability

The risk of spinal injury during ejection has been evaluated previously by Stech (31). Vertebra L1 was found to be the weakest element in the spinal column. The probability of endplate damage, proportional limit failure, and compression failure are shown in Figure 7.

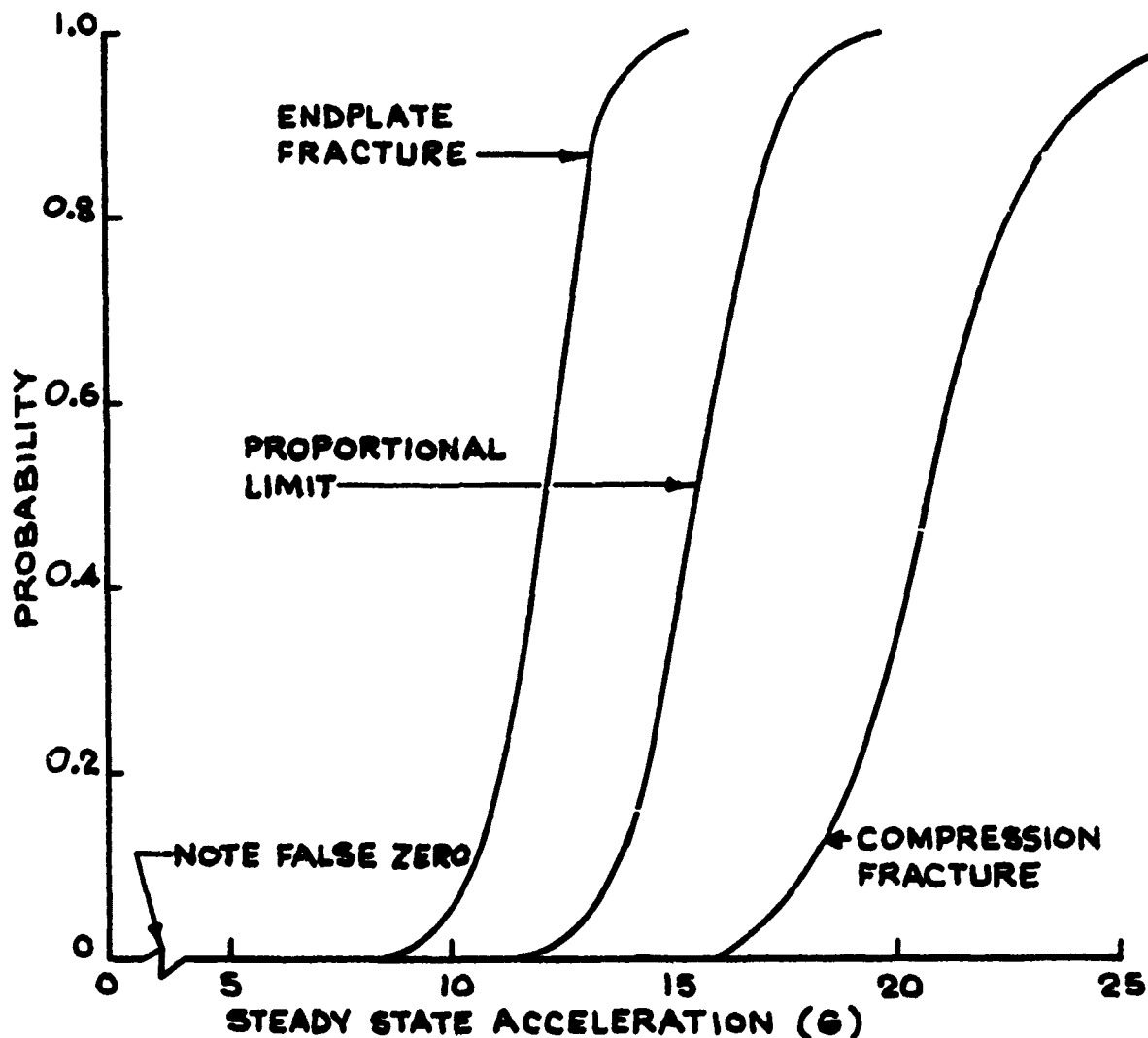

FIGURE 7
 PROBABILITY OF DAMAGE TO VERTEBRA L1

In order to evaluate the effect of cushion dynamics on injury risk, data published in Bondurant's report were converted to overshoot ratio, that is, input peak acceleration divided into peak acceleration on the occupant. The resulting curve is shown in Figure 8.

An input peak acceleration of 15 G's was taken as an arbitrary but representative value of ejection seat loads. Multiplying the overshoot values from Figure 8 times 15 G's gave an estimate of the peak acceleration applied to the occupant which in turn was used with Figure 7 to obtain probability of injury values. Three curves, one for each mode of failure, are presented in Figure 9.

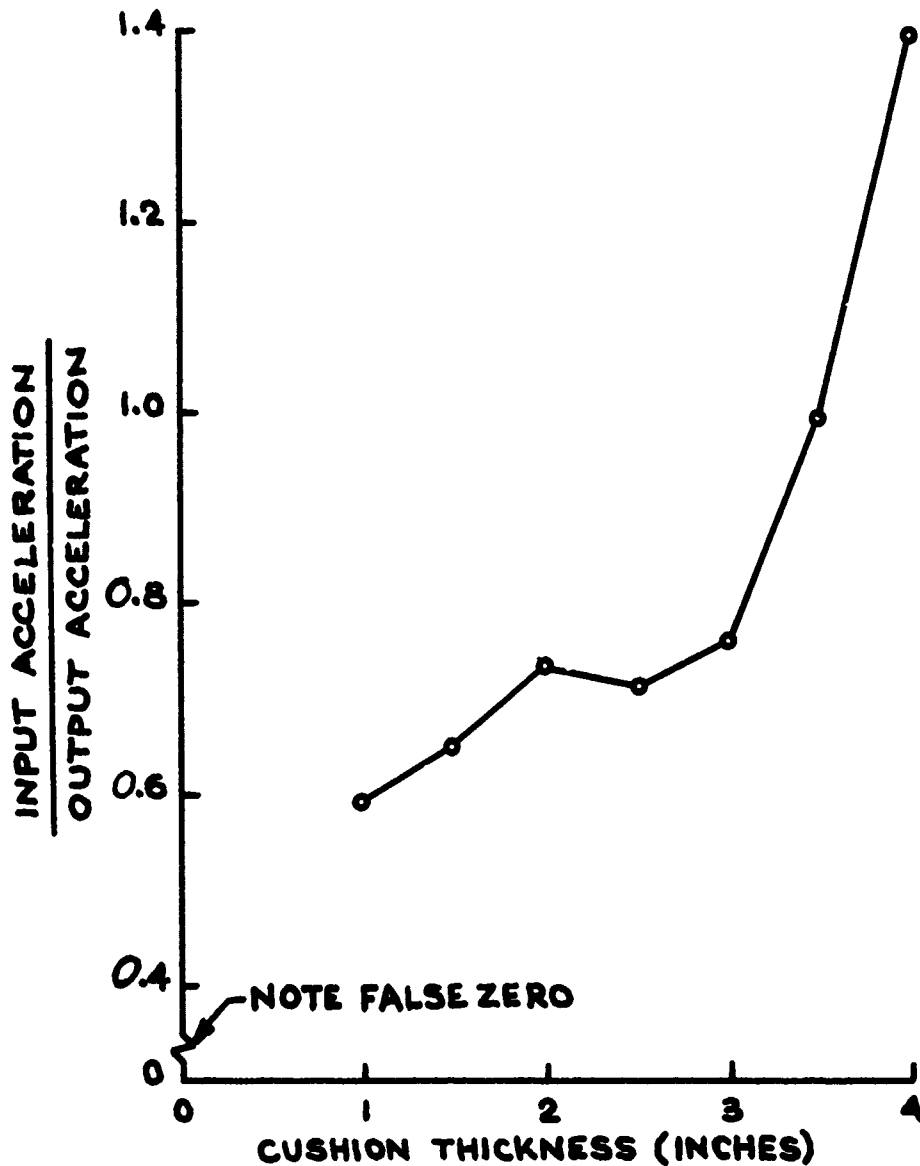
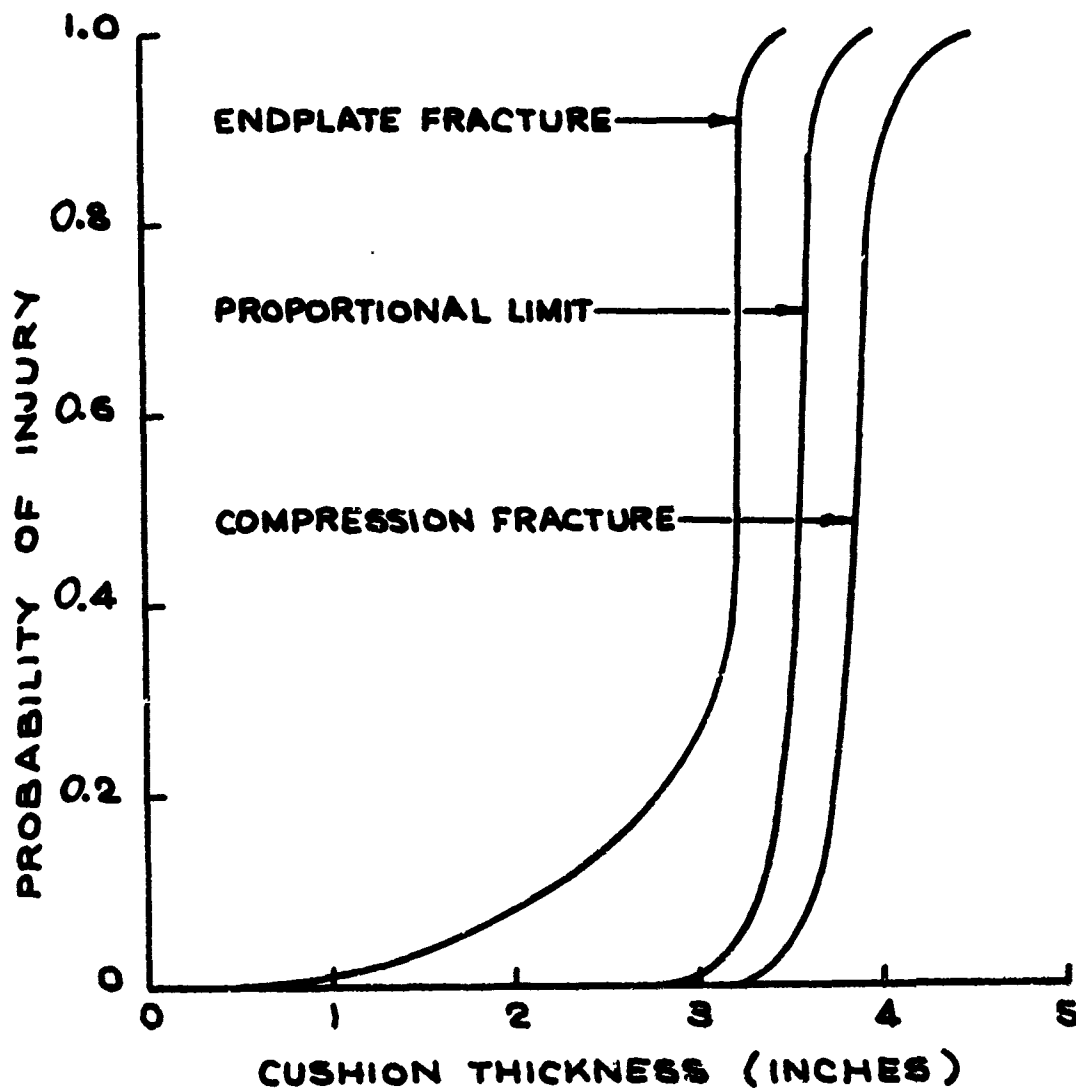

FIGURE 8
 DATA ADAPTED FROM BONDURANT (2) SEAT
 CUSHION TESTS SHOWING ATTENUATION AND AMPLIFICATION

**NOTE: BASED ON 15 G'S PLATEAU AND
USING BONDURANT'S OVERSHOOT
DATA (2)**



**FIGURE 9
THE RELATIONSHIP OF INJURY PROBABILITY
TO CUSHION THICKNESS FOR A LATEX CUSHION**

Optimization of Injury Probability and Comfort

To summarize, the relationship of cushion thickness (or stiffness) to the important parameters of comfort and injury risk can be measured while vibration isolation is a minor function of a cushion. The optimization problem is how to quantify comfort and injury risk. Comfort must be evaluated subjectively. Injury probability can be estimated using the approach illustrated previously. The two measures appear to be incapable of useful combination into an optimization procedure.

The only possible method available is to convert cushion comfort measures into probability values, a procedure which is feasible. In fact, one of the best and only ways to evaluate subjective estimates is to compare them to a standard condition evaluation through a t ratio test or some similar statistical measure of significance. If the benchmark condition is a rigid seat pan, all foam cushions can be compared to the stiff pan using the average comfort estimate for each condition plus the variance in estimates. The result is a probability that the cushion is in fact more comfortable than a rigid seat pan. An example is shown in Figure 10, taken from comfort tests conducted in this program and to be discussed in more detail later.

Using the data from Figure 9 on injury probability and from Figure 10 on comfort probability, the curves in Figures 11 and 12 were generated for endplate fracture and compression fracture respectively. The procedure involves subtracting the injury probability from the comfort probability and plotting the resulting points. For endplate fracture as an injury mode, the optimization curve is reasonably flat from 1-1/2" to 2-1/2" with a sharp cutoff at 3". The curve for compression fracture is flat from 2" to 3" with a sharp drop from 3" to 4". In terms of either endplate or compression fracture, there is no particular advantage to a thickness greater than 2". So the result of the optimization is a thickness of 2" of polyurethane foam for the ejection conditions specified.

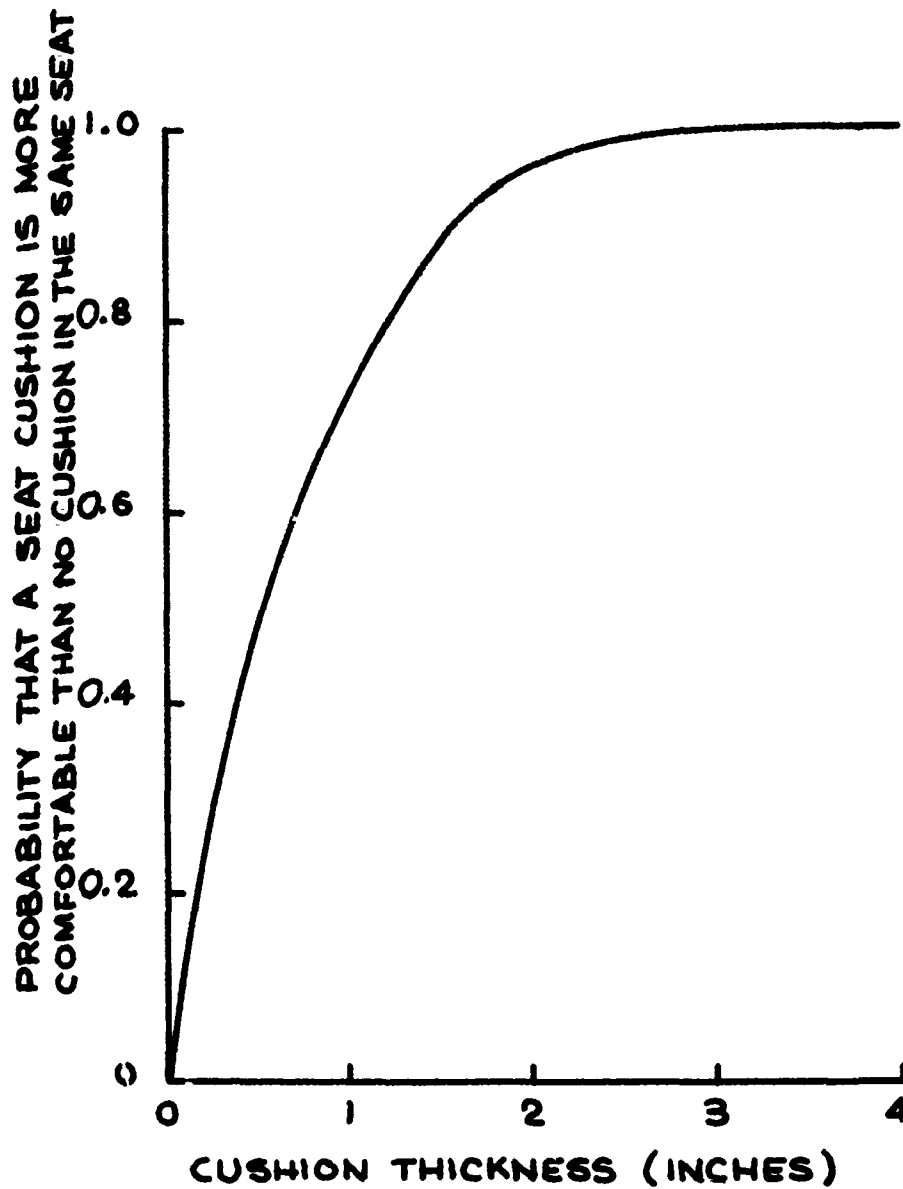

FIGURE 10
 AN EXAMPLE OF SUBJECTIVE COMFORT ESTIMATES EXPRESSED
 AS A PROBABILITY REFERRED TO A NO-CUSHION CONDITION

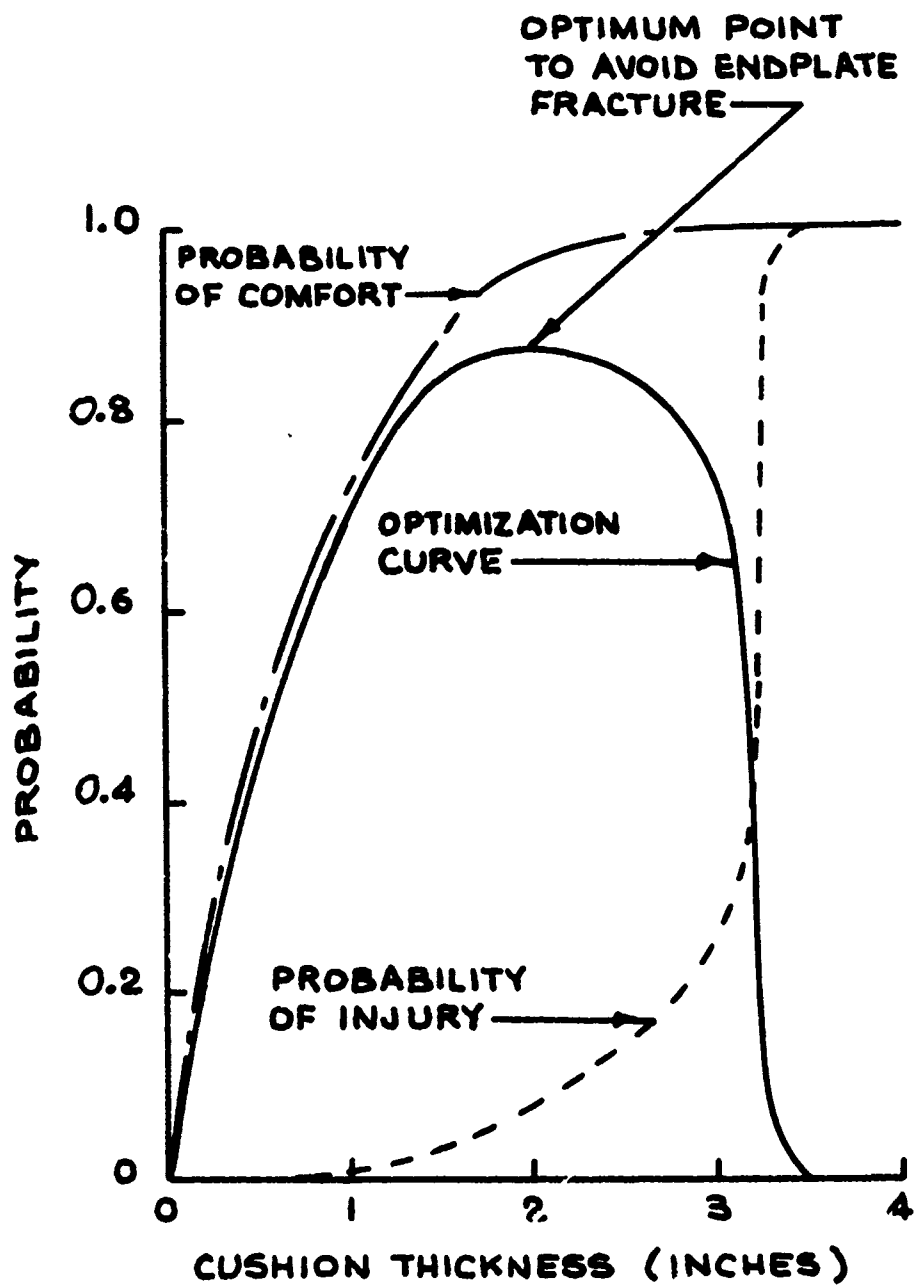

FIGURE 11
AN EXAMPLE OF OPTIMIZATION USING ENDPLATE FRACTURE
DATA FROM FIGURE 9 AND COMFORT DATA FROM FIGURE 10

OPTIMUM THICKNESS TO AVOID COMPRESSION FRACTURE

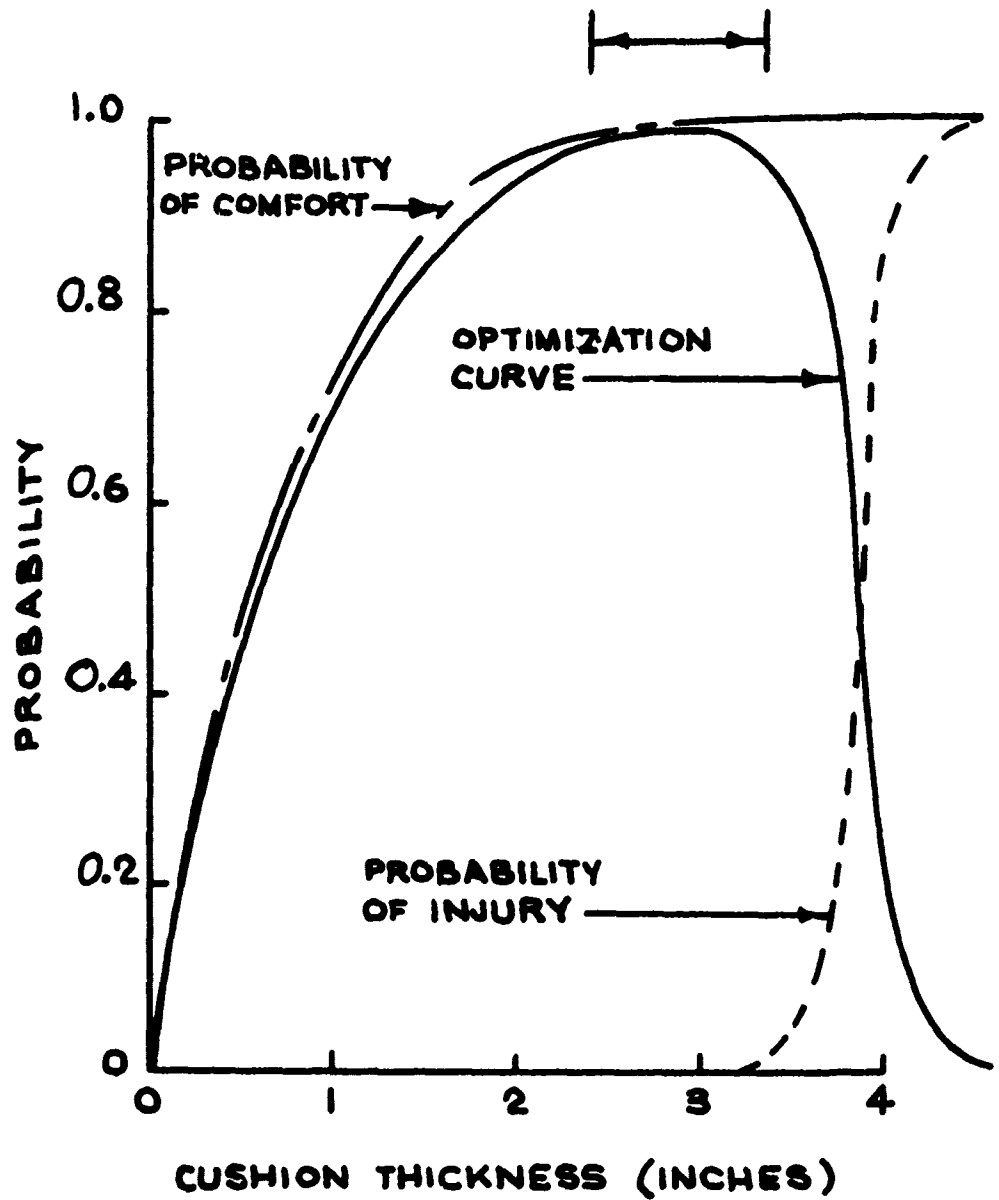

FIGURE 12
AN EXAMPLE OF OPTIMIZATION USING COMPRESSION FRACTURE
DATA FROM FIGURE 9 AND ACTUAL COMFORT TEST RESULTS

OPTIMIZATION CRITERIA FOR THE PRESENT PROGRAM

In preceding paragraphs, data from various sources were used to illustrate the general procedure to be employed in optimizing the passive or active developmental cushions which were the goal of the present program. Injury risk estimates for the developmental cushions were made using the acceleration-time history of an operational ejection seat. Figure 13 shows the acceleration pulse supplied by the Contract Monitoring Agency and the smoothed version employed in the analog computer studies, results of which are reported later in this report. The analog work was performed by Payne Division of Wyle Laboratories and the methods employed are summarized in Appendix A.

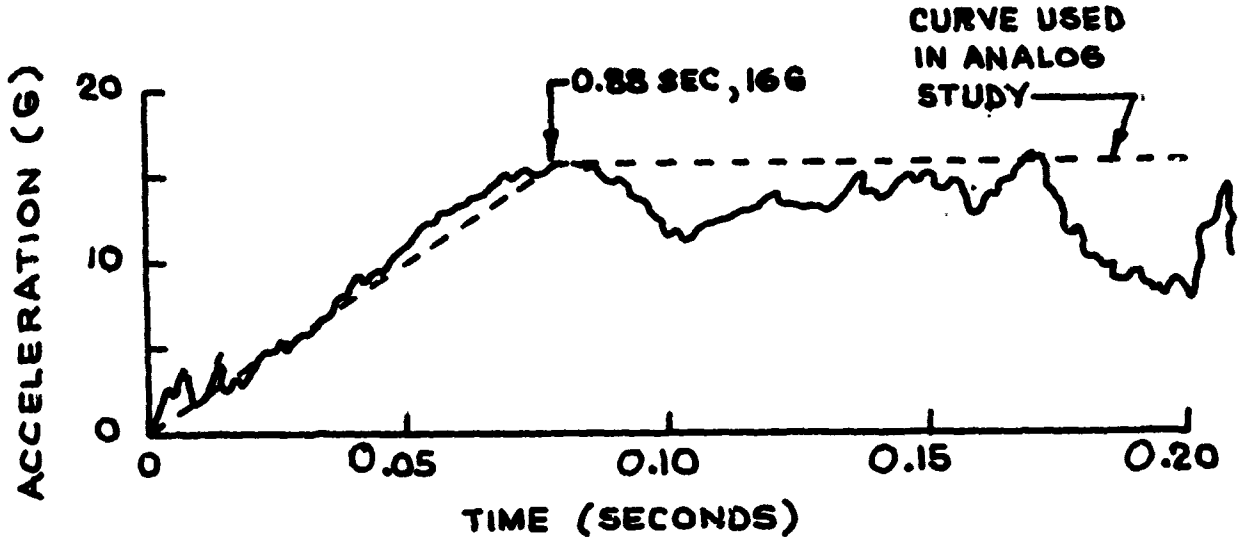

FIGURE 13
TRANSIENT ACCELERATION INPUT

SECTION III

TESTS OF TWO OPERATIONAL AIR FORCE SEAT CUSHIONS

IDENTIFICATION OF THE SAMPLES:

Two seat cushions from operational aircraft were provided as Government Furnished Property by the Contract Monitoring Agency to serve as a comparative baseline for subsequent cushion optimization. Before performing mechanical and comfort tests of the operational seat cushions, a detailed visual inspection was made and dimensions were taken.

One cushion was identified as FSN 16607909760, with a Contractor's Part No. F3460167-C9709. This was a molded latex foam cushion with 5/8" cores on 1-1/8" centers. The cushion was contoured with a thicker front edge than rear edge. Two tuberosity depressions, approximately 1/2" to 3/4" deep and on 8" centers, were formed into the bottom of the cushion. The shape of the cushion and its general configuration are shown in Figure 14. The measured density of the cushion was 4.83 lbs. per cubic foot.

The other cushion was identified as FSN 16609192790. This cushion bore a Contractor's Part No. 140452-1. The cushion was molded of polyurethane with a contour similar to that of the latex cushion. A photograph showing the general configuration of this cushion is presented as Figure 15. The measured average density of the total cushion was 6.44 lbs. per cubic foot. One of these cushions was cut up for visual examination of its interior after testing, and rather large density variations were apparent in the cross-section. Large voids or holes occurred along the material flow pattern during molding and a high density crust was evident along the bottom surface of the cushion.

The first cushion described above was identified as an F101 ejection seat cushion, while the second cushion was identified as a F104 ejection seat cushion. In the remainder of this report, these cushions will be referred to as the F101 and F104 cushions respectively.

STATIC LOAD-DEFLECTION TESTS .

A series of load-deflection tests were run using the test method described in Appendix B to this report. Three indenter feet were used, and the results are plotted in Figures 16 and 17 for the F101 and F104 cushions respectively. The load-deflection requirements of MIL-S-27332A (USAF) have been included in the graphs for comparison purposes.

Since the MIL-S-27332A tests are arbitrary laboratory procedures, data were needed on the indentation of human buttocks into the two cushions for comparison purposes. Six subjects in turn were seated on each cushion. Deflection was measured by means of two pins, one under

each tuberosity, which were pushed downward through holes in the seat pan. Measurements were made with the legs in the extended and tucked positions. The averages for six subjects are plotted in Figures 18 and 19. There is little difference between the two sitting conditions for the soft latex foam F101 cushion. Tucking the legs does make a difference on the F104 cushion, and the tucked position approximates the deflection obtained with all three indenter feet on the static test rig, coming closest to the double ellipsoid curve. Indentation of the F104 cushion with live human subjects is less than that obtained in static tests.

Another series of tests were run in which various loads were applied to the subjects' buttocks in the legs extended position. This was done by having the subjects relieve part of their sitting weight by raising themselves on an overhead bar. Then sets of weights ranging from 25 to 100 pounds were held by the subject to obtain higher buttock loads. The results of these tests are shown in Figures 20 and 21. For the F101 cushion, the load-deflection curve obtained in this way is not the same shape as the laboratory test machine curves. The F104 cushion curve from the human subject tests appears to be similar to the indenter foot curves, although the limited range of testing possible with the human subjects does not permit a very adequate evaluation.

The static load-deflection tests plus the human buttock indentation tests lead to several conclusions that are important to seat cushion design. First, different indenter foot shapes give different load-deflection curves. Second, the human buttocks may indent seat cushions differently when the legs are extended and tucked. Third, human buttock load-deflection curves may differ from all three of the indenter feet used in the static tests in this program. These conclusions show that results obtained in mechanical laboratory tests must be evaluated cautiously and used with extreme care in design analysis.



FIGURE 14
LATEX FOAM F101 EJECTION SEAT CUSHION

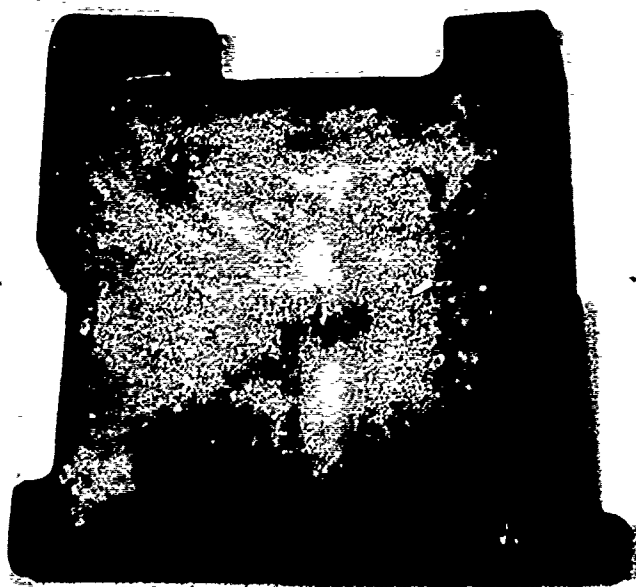

FIGURE 15
POLYURETHANE F104 EJECTION SEAT CUSHION

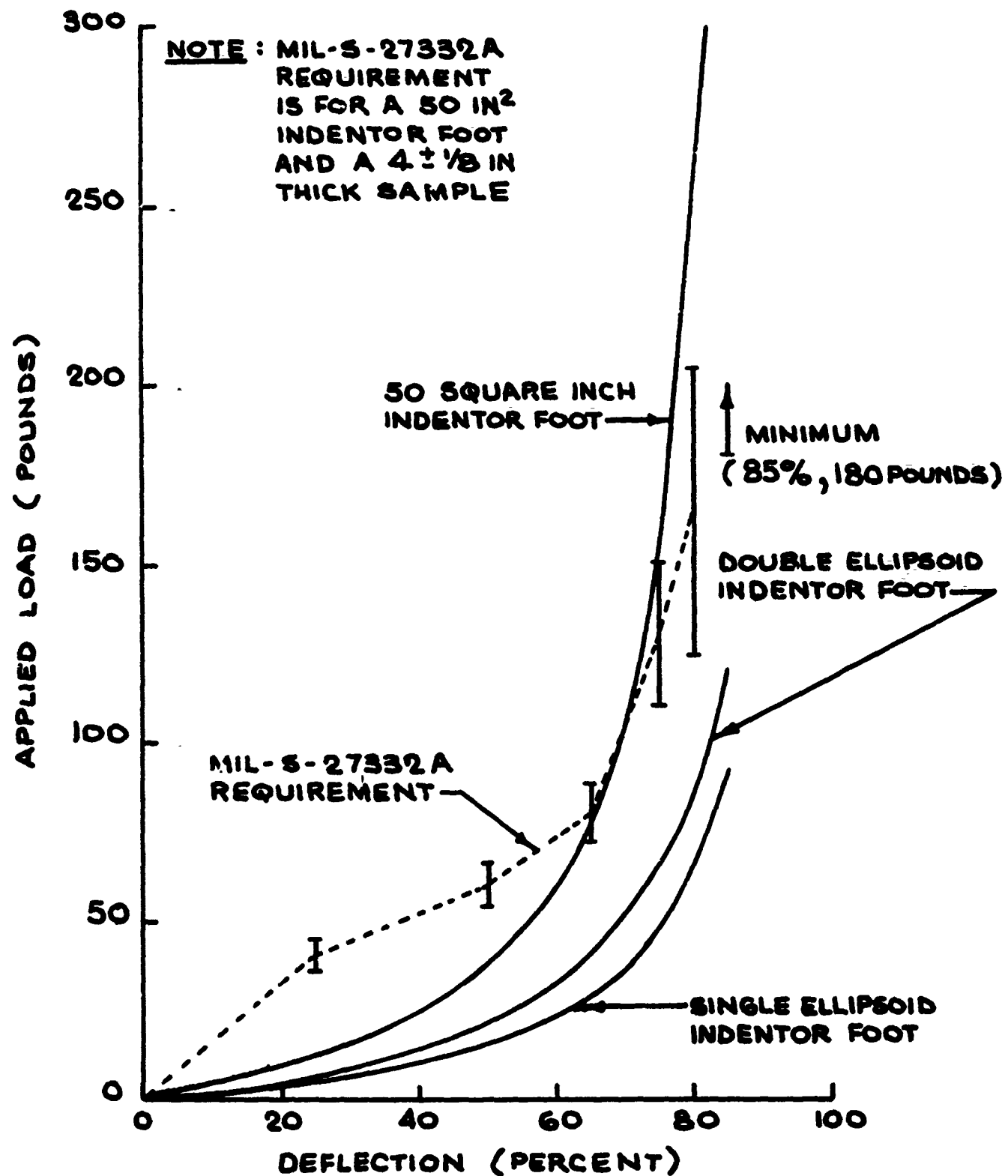

FIGURE 16
MIL-S-27332A (USAF) LOAD-DEFLECTION
VALUES FOR THE F101 EJECTION SEAT CUSHION

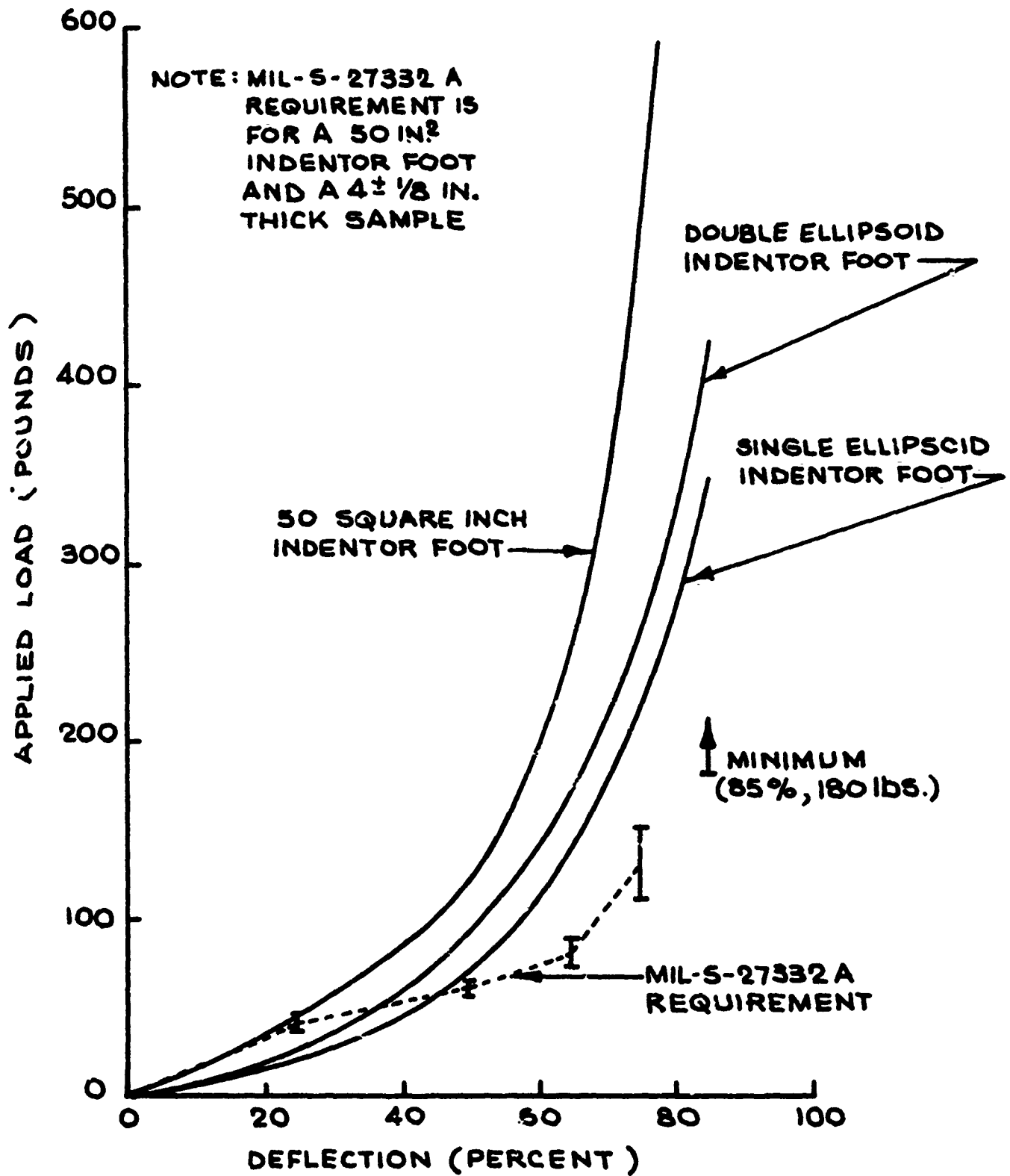

FIGURE 17
MIL-S-27332A (USAF) LOAD-DEFLECTION
VALUES FOR THE F104 EJECTION SEAT CUSHION

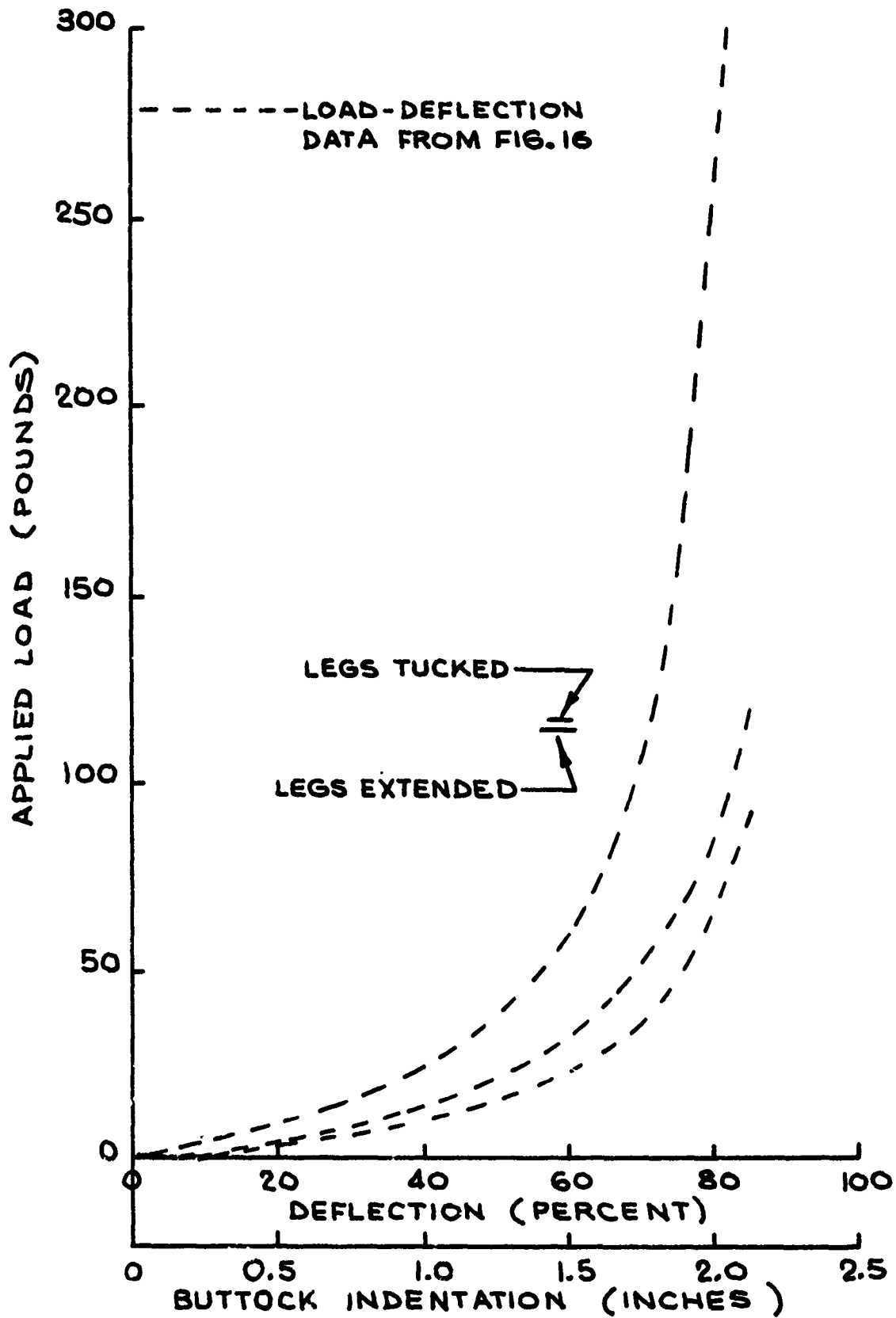

FIGURE 18
HUMAN BUTTOCK INDENTATION WITH LEGS EXTENDED
AND LEGS TUCKED FOR THE F101 EJECTION SEAT CUSHION

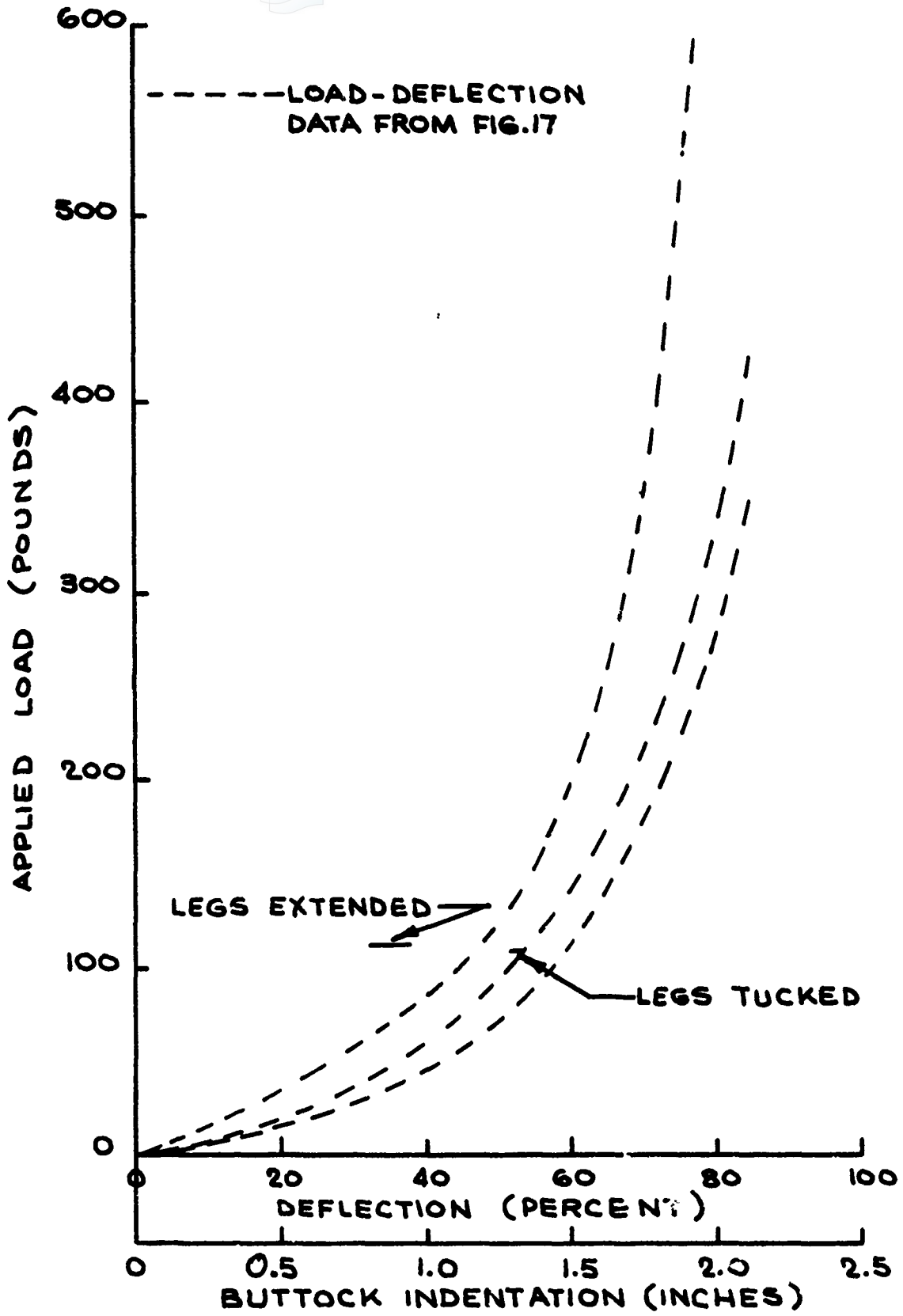

FIGURE 19
HUMAN BUTTOCK INDENTATION WITH LEGS EXTENDED
AND LEGS TUCKED FOR THE F104 EJECTION SEAT CUSHION

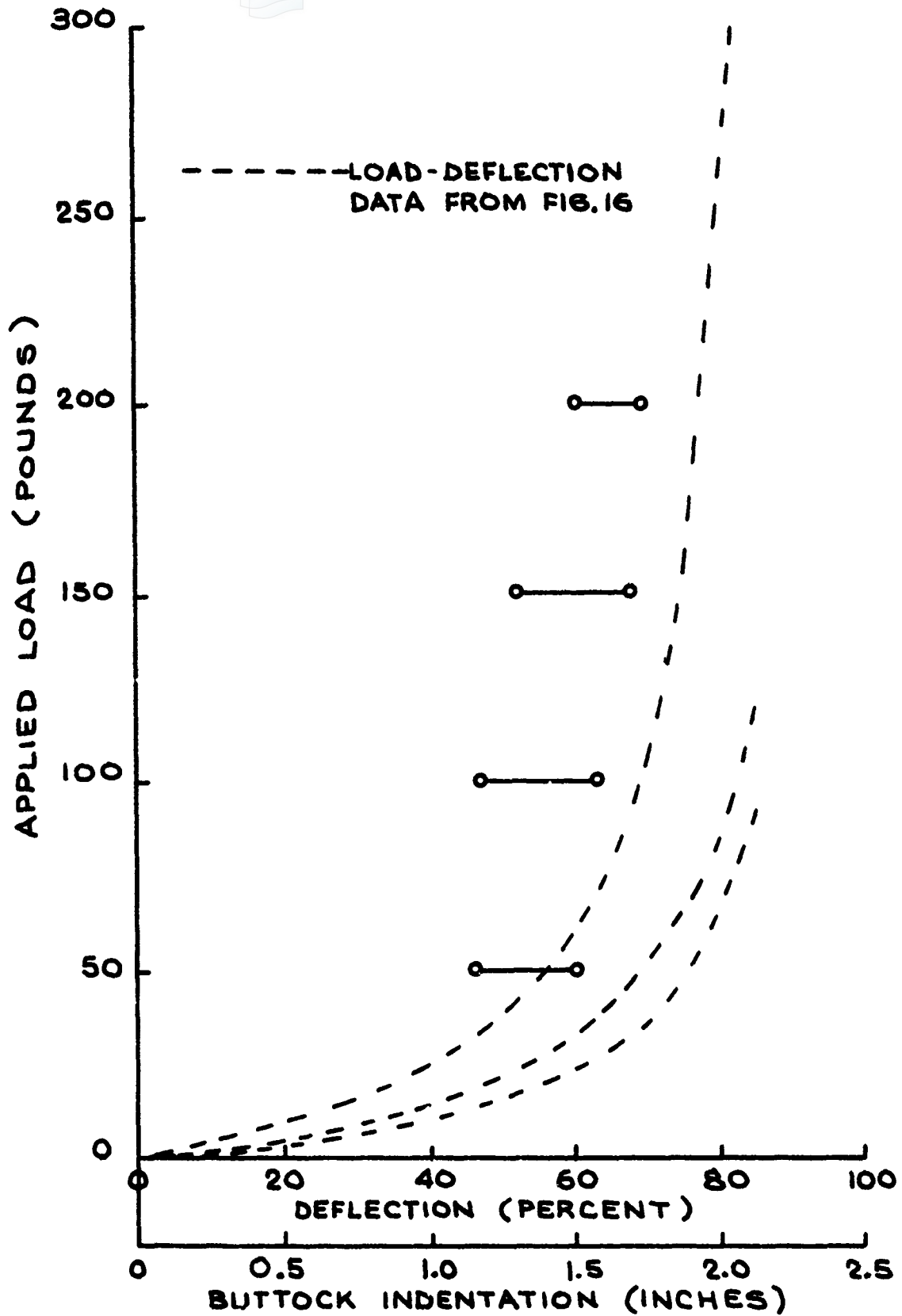

FIGURE 20
HUMAN BUTTOCK INDENTATION WITH LEGS EXTENDED AND
VARYING APPLIED LOADS FOR THE F101 EJECTION SEAT CUSHION

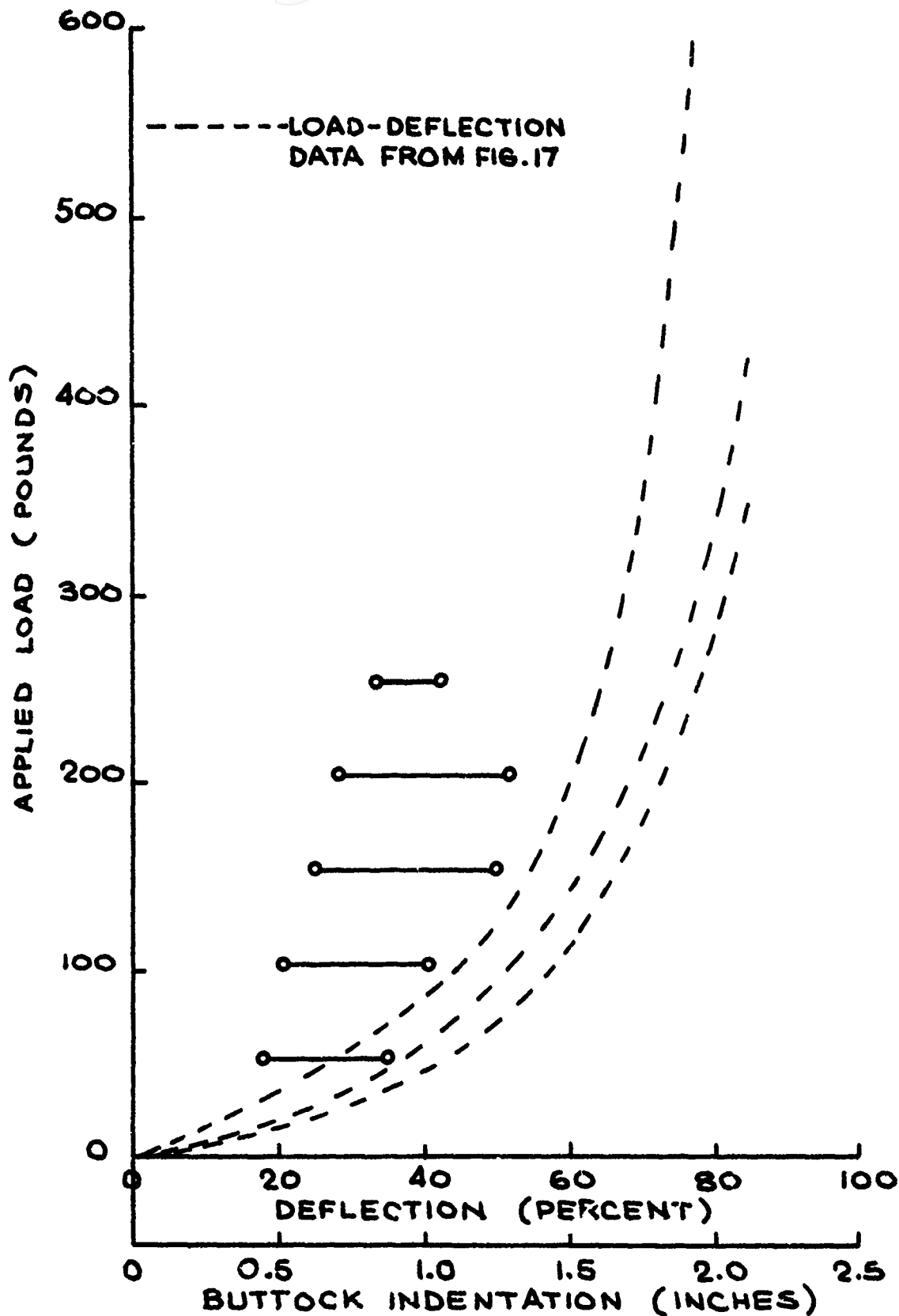

FIGURE 21
HUMAN BUTTOCK INDENTATION WITH LEGS EXTENDED AND
VARYING APPLIED LOADS FOR THE F104 EJECTION SEAT CUSHION

DYNAMIC REBOUND TESTS

Since the damping of the seat cushion can affect the dynamic overshoot experienced in the ejection, tests were conducted on the F104 and F101 cushions to obtain an estimate of the damping coefficient for each. The results of the rebound resilience tests are shown in Figure 22. The F101 cushion, consisting of cored latex foam, exhibits a gradually increasing damping ratio from impact velocities of 3 feet per second up to 8 or 9 feet per second. The F104 cushion, with slightly different characteristics, has a constant damping ratio up to 8 or 9 feet per second. Both curves increase sharply between 8 or 9 feet per second due to bottoming effects. When the cushion bottoms, the pendulum arm is impacting, for all practical purposes, into the rigid support stage used to hold the cushion specimens. Beyond the bottoming point, the damping ratio values are a combination of the damping of the pendulum arm and structure and of the seat cushions.

These tests illustrate the difficulty in obtaining reasonable damping coefficient estimates with highly non-linear materials which also exhibit sharp bottoming characteristics. The difficulty is quite serious. For example, the F104 cushion is bottomed to all intents and purposes at 1G with a 200-210 lb. subject on it. This can be seen in Figure 17. Because of this characteristic, the damping ratio values shown in Figure 22 for the same cushion represent the damping from no deflection to to the 1.0 - 1.5 G deflection point for average size occupants. The damping ratio, with the cushion bottomed, cannot be tested adequately without an extremely stiff impact pendulum.

These tests illustrate the difficulty in obtaining damping coefficient estimates, but they also raise the question of how important the damping coefficient is in real cushions. The precise magnitude of the damping ratio probably is not very important in analog computer studies, a typical ratio of 0.2 being adequate for such analyses.

COMFORT TESTS

Comfort testing was conducted by having a panel of 14 subjects rate the cushions over a four-hour sitting period as described in the appendix on test methods. Each subject was given a pre-test and post-test questionnaire plus an hourly questionnaire. In addition to subjective ratings, measurements were made of the pressures underneath the ischial tuberosities of each subject for each cushion.

The average tuberosity pressure for the F104 cushion was 1.21 psi and for the F101 cushion, 1.89 psi. These averages represent 28 data points, representing the right and left tuberosity pressures for 14 subjects. A more complete discussion of the tuberosity pressures and comfort ratings is presented later in this report, at which time the tuberosity pressure values are interpreted more fully.

NOTE: MEASUREMENTS MADE WITH A REBOUND PENDULUM WITH AN EQUIVALENT MASS OF 65 POUNDS

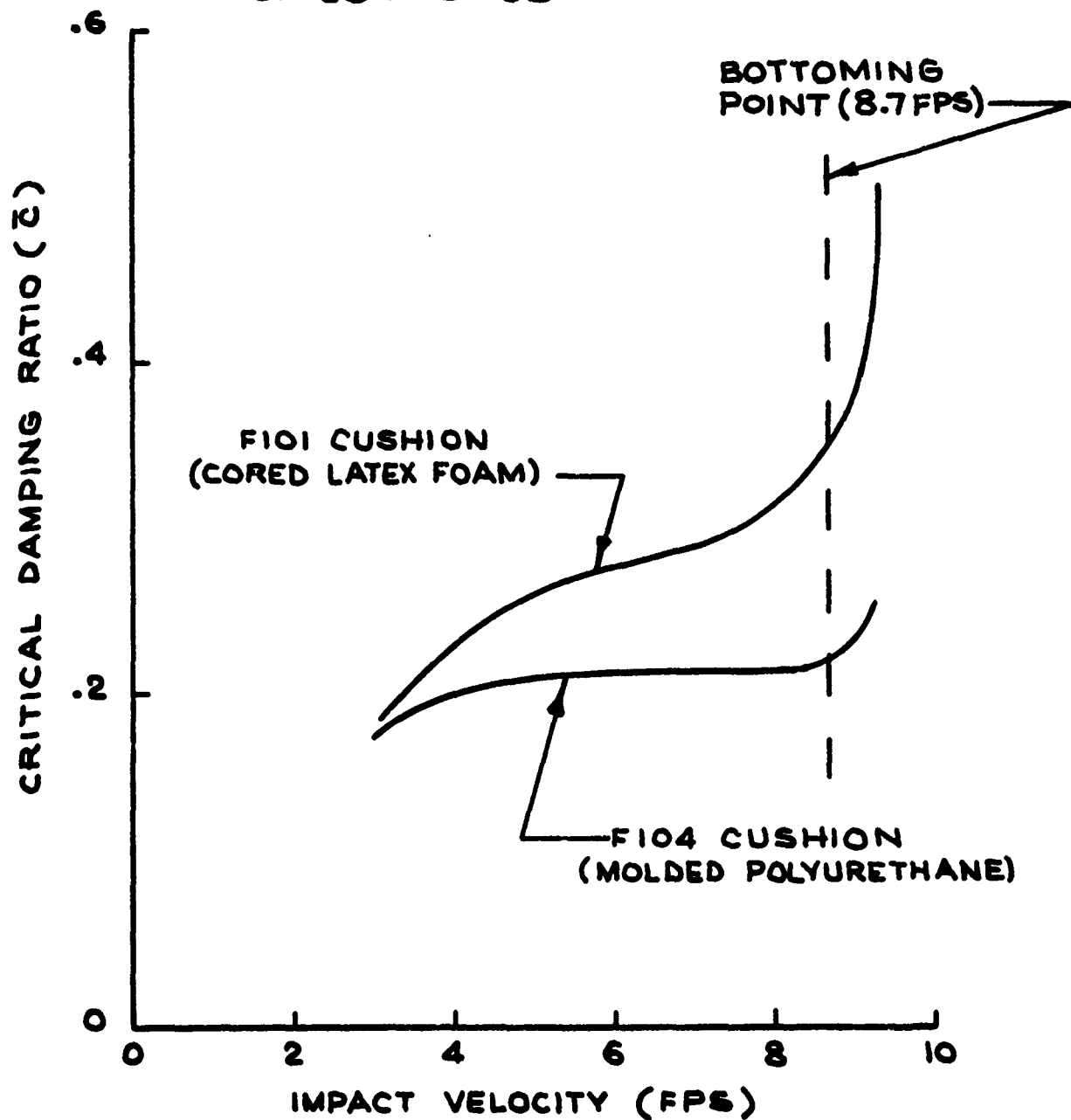

FIGURE 22
CRITICAL DAMPING RATIO FOR
TWO OPERATIONAL SEAT CUSHIONS

The two cushions were compared using four different measures. Each subject was asked to rate the degree of comfort of the seat on an overall basis, to estimate the number of hours he could continue to sit in the seat, and to rate the degree of discomfort of the buttocks. These questions were asked at the beginning of the first hour of the test, and thereafter at the end of each hour. Figures 23, 24, and 25 show the time trend for each of these three ratings.

Each subject was also required to rate the overall degree of comfort of the seat as part of the post-test questionnaire. The statistical tests of significance on this rating plus the overall comfort and buttock discomfort showed no significant difference between the cushions. A summary of the statistical tests is presented in Table I.

TABLE I
 STATISTICAL SIGNIFICANCE OF THE DIFFERENCES BETWEEN
 TWO AIR FORCE OPERATIONAL SEAT CUSHIONS

	F101 Latex Foam		F104 Molded Polyurethane		Difference in Means	t Ratio	Signifi- cance
	Mean Rating	Standard Error	Mean Rating	Standard Error			
Overall Comfort	0.90	0.21	0.80	0.18	0.10	0.3616	0.7
Buttock Discomfort	0.74	0.10	0.74	0.12	0.00	0.0000	None
Post-Test Final Rating	2.18	0.78	3.15	0.91	0.97	0.8093	0.4

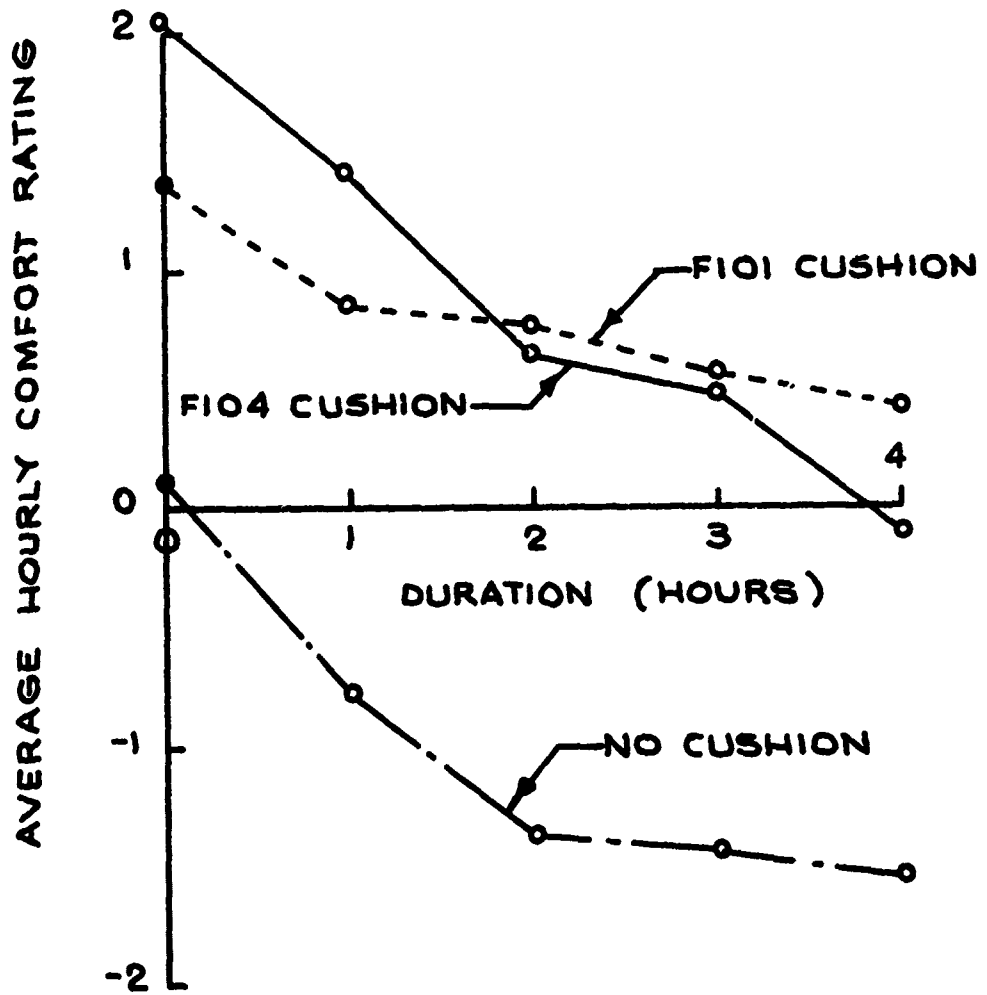

FIGURE 23
AVERAGE HOURLY COMFORT RATING FOR
TWO AIR FORCE OPERATIONAL SEAT CUSHIONS

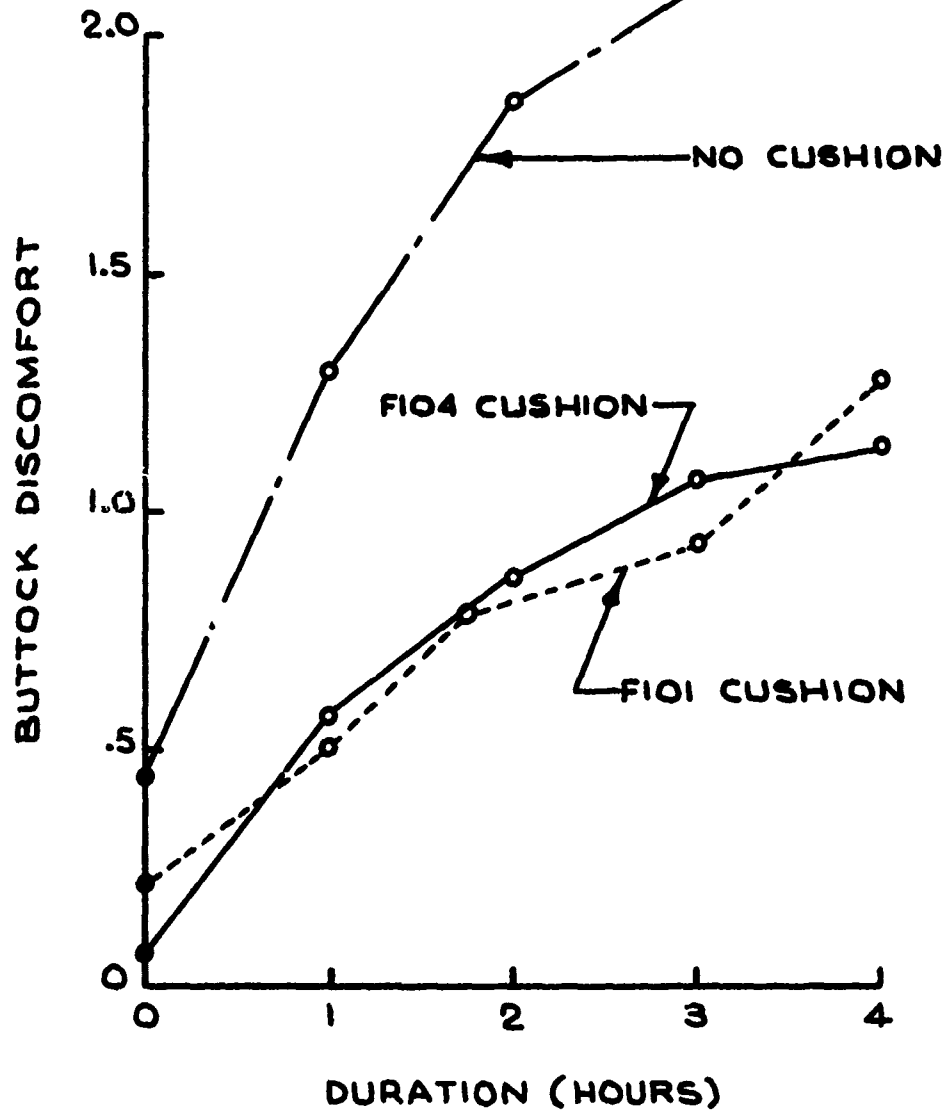

FIGURE 24
AVERAGE HOURLY BUTTOCK DISCOMFORT FOR
TWO OPERATIONAL AIR FORCE SEAT CUSHIONS

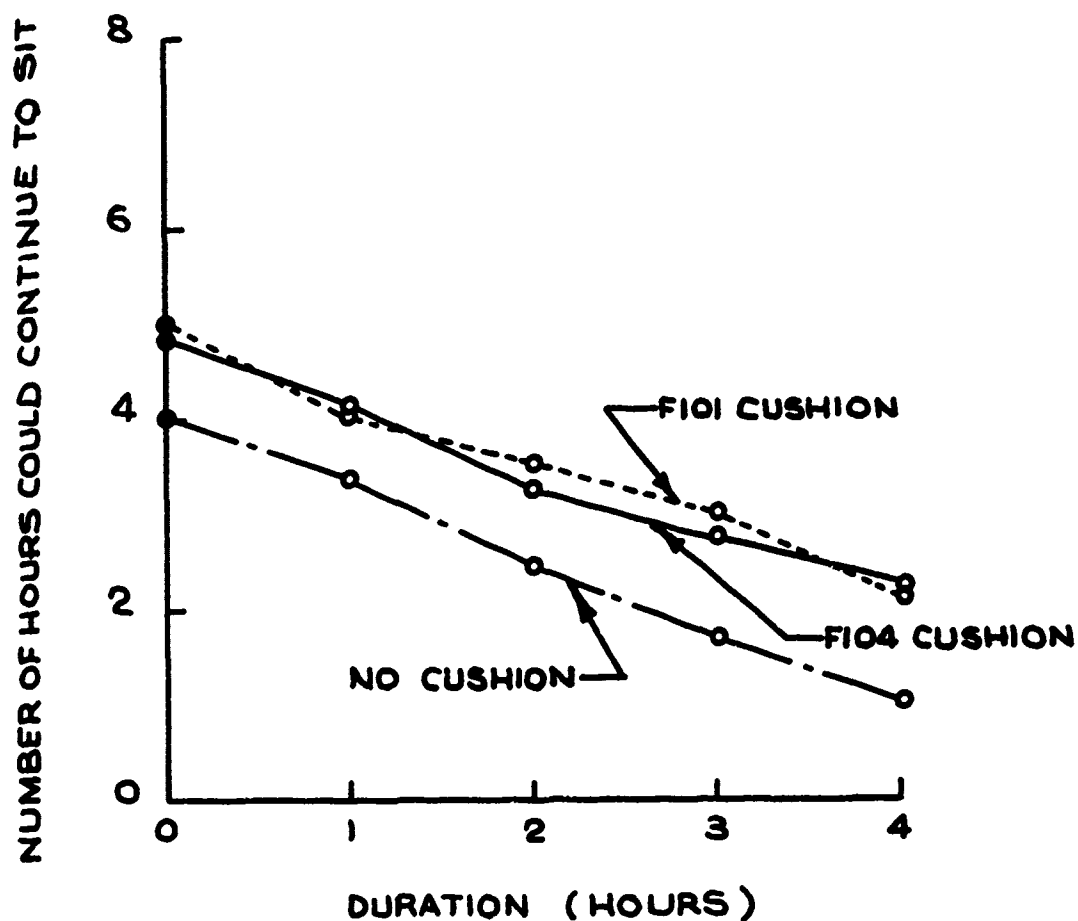

FIGURE 25
THE NUMBER OF HOURS SUBJECTS ESTIMATED THEY COULD
CONTINUE TO SIT FOR TWO AIR FORCE OPERATIONAL SEAT CUSHIONS

DYNAMIC RESPONSE ANALYSIS

Analog computer studies of the two cushions were conducted to obtain an estimate of dynamic response effects. Details of the analog procedures are presented in Appendix A as reported by Payne Division of Wyle Laboratories. The operational ejection seat acceleration-time history presented earlier as Figure 13 was used as the forcing function in the computer. Both cushions resulted in an amplification of 1.15 times the input peak acceleration, so no difference in dynamic response was found.

CONCLUSIONS ON THE OPERATIONAL AIR FORCE SEAT CUSHIONS

The F101 and F104 cushions can be compared on the basis of the static load-deflection tests, dynamic rebound tests, comfort tests, and analog computer results. The F101 cushion, manufactured of latex foam, showed a nonlinear load-deflection curve which exhibited a damping ratio which increased from 0.2 to 0.3 over the range of impact velocities used in the dynamic rebound tests. The F104 cushion deflected to a lesser extent, having approximately 50% of its total thickness left under a 120-pound load. The damping ratio of the F104 cushion was relatively constant at 0.20 until bottoming began with the impact pendulum. Analog computer results showed that both cushions exhibited a dynamic amplification of 1.15 over a rigid seat pan, no-cushion condition.

The comfort evaluation showed no statistically significant difference between the two cushions, although the F104 cushion gave a lower tuberosity pressure value. No consistent trend was evident in the comfort evaluations either, so the cushions must be judged as equivalent in comfort terms.

SECTION IV

DEVELOPMENT OF AN OPTIMUM PASSIVE CUSHION

DISCUSSION

Based on a review of literature and the tests conducted on the operational seat cushions, there was an obvious need for more data on the relationship of comfort to cushion thickness. Some information was available and test techniques had been worked out, but very little was known about comfort characteristics of cushions. The test procedures developed by Slechta, *et. al.* (25) and discussed in Appendix B in this report seemed appropriate for obtaining subjective evaluations. The passive cushion optimization was initiated by running comfort tests.

POLYURETHANE FOAM COMFORT TESTS

The initial polyurethane foam comfort tests were conducted on 1.6 lb. per cubic foot foam in thicknesses of 1/2, 1, 1-1/2, and 2 inches. Subsequently, the tests were run on 3 and 4 inch thick foams.

The foam samples were obtained from a local supplier and identified as Marco Chemical Company, Type 1.75 SE, with a measured density of 1.68 lbs./ft³. The material was tested in accordance with MIL-S-27332(A) for tensile strength, elongation, compression set, and tear resistance. The results are shown in Table II and the material met all the specification requirements. The data plotted in Figures 26, 27, 28, and 29 represent the average hourly ratings for the zero-thickness or no-cushion condition and the 1/2", 1", 1-1/2", 2", 3", and 4" thick foam samples. These data represent the averages for 14 subjects except for the 1" thickness. In the latter case, data from only 13 subjects were used since the 14th subject did not stay in the seat for the full four hours.

In Figure 26, the average hourly comfort ratings show a steady decrease with the thinner cushions being less comfortable almost all the way through the sessions. The no-cushion condition and the thicknesses up to 1-1/2" become asymptotic between three hours and four hours. This also occurs for the 2" foam, although the asymptote is at a much higher rating. The 3" and 4" thicknesses are not asymptotic at the end of four hours.

Figure 27 shows the number of hours subjects estimated they could continue to sit for four thicknesses of the foam. Only the thinner cushions are shown on this graph. A steady decrease in the number of hours subjects estimated they could continue to sit is shown in the figure. The data for the two thicker cushions are shown in Figure 28. The reason for the difference between the graphs is that the estimating procedure was changed for the subjects after the thinner cushions had been evaluated. During the tests on the 0" - 2" foam thicknesses, the subjects were allowed to provide any initial estimate of hours that they desired. This seemed to

lead to a rather variable estimating situation with very little difference between the cushions as can be seen in Figure 27. Therefore, the procedure was changed on the 3" and 4" cushions. The change involved having each subject begin his estimation at 8 hours, a direction included in the subject's initial instructions after being seated on the cushion. Unfortunately, this change did not affect the variability of the scores in the desired direction.

The average hourly buttock discomfort for the four hour sitting period is shown in Figure 29 and as expected, the discomfort increases steadily over the entire sitting period. Again, the curves for the thinner cushions seemed to become asymptotic between three and four hours. In the case of the buttock discomfort rating, the thicker cushions also seemed to have reached an asymptote.

Another mode of analysis of the data is to relate the subjective comfort ratings to cushion thickness. The tuberosity pressure measured with the cushion can be related to its thickness, the data for the 1.6 lb/ft³ foam being shown in Figure 30. As expected, the tuberosity pressure decreases as the thickness of the foam increases. In Figures 31, 32, 33, and 34, the average hourly comfort rating, number of hours subjects estimated they could continue to sit, buttock discomfort, and post-test comfort rating are plotted against cushion thickness. The data points represent an average of the hourly ratings presented in the preceding graphs. Each point represents the ratings of 14 subjects on five different questionnaires for a total of 70 estimates.

The preceding data are of interest in terms of the time trends, thickness trends, and tuberosity pressure trends exhibited in the graphs. However, the data are relatively difficult to interpret from a design standpoint. The comfort rating data can be analyzed by statistical procedures and additional insight gained into the importance of cushion thickness. The procedure adopted was a comparison between the zero-thickness condition and the six thicknesses of foam tested. A t-test of significance was performed on the data.

Results are shown in Tables III, IV, V, and VI. The values reported in the tables can be interpreted easily. For example, the difference between a zero-thickness cushion and 1/2" of polyurethane foam was found to be significant at the 0.40 level. This means that there is about a 40% chance that the two conditions would be rated as equal or that the zero-thickness condition would be rated more comfortable than 1/2" of foam by another subject panel. The difference between the zero-thickness condition and 1" of foam gives a significance of 0.10. Again, this implies that there is a 10% chance that the 1" foam is not truly different from no foam at all. In the case of 2" foam versus no cushion, the chances are only one in 1,000 that the no-cushion condition is actually more comfortable.

The same form of interpretation is possible with Tables IV, V, and VI. In effect, these tables provide a basis for evaluating the importance of the subjective evaluation in terms of human average judgments. Adopting

the convention of a 5% significance level, it is evident that the designer must use at least a 1-1/2" foam thickness and preferably a 2" thickness to achieve a statistically significant improvement over the zero-thickness condition.

TABLE II

PHYSICAL CHARACTERISTICS OF THE 1.6 LB/FT³
POLYURETHANE FOAM USED IN COMFORT TESTS

MIL-S-27332 TESTS

Density, Average:	1.68 lb/ft ³
Tensile Strength:	18.2 lb/inch
Elongation:	187%
Compression Set:	7.0%
Tear Resistance:	2.78 lb/inch

TABLE III

THE STATISTICAL SIGNIFICANCE OF THE
DIFFERENCE IN OVERALL COMFORT RATING
FOR SIX THICKNESSES OF 1.6 LB/FT³ POLYURETHANE FOAM

Difference Between	t	Significance Level
0"-1/2"	0.95	0.40
0"-1"	2.10	0.05
0"-1-1/2"	2.18	0.05
0"-2"	4.76	0.001
0"-3"	7.108	0.001
0"-4"	12.287	0.001

TABLE IV

THE STATISTICAL SIGNIFICANCE OF THE DIFFERENCE IN NUMBER OF HOURS SUBJECTS ESTIMATED THEY COULD CONTINUE TO SIT FOR FOUR THICKNESSES OF 1.6 LB/FT³ POLYURETHANE FOAM

Difference Between	t	Significance Level
0"-1/2"	0.73	0.50
0"-1"	2.63	0.02
0"-1-1/2"	1.73	0.10
0"-2"	2.83	0.01

TABLE V

THE STATISTICAL SIGNIFICANCE OF THE DIFFERENCE IN BUTTOCK DISCOMFORT FOR SIX THICKNESSES OF 1.6 LB/FT³ POLYURETHANE FOAM

Difference Between	t	Significance Level
0"-1/2"	0.68	0.50
0"-1"	1.41	0.20
0"-1-1/2"	1.55	0.20
0"-2"	2.77	0.01
0"-3"	6.275	0.001
0"-4"	7.635	0.001

TABLE VI

THE STATISTICAL SIGNIFICANCE OF THE DIFFERENCE IN POST-TEST FINAL RATING FOR SIX THICKNESSES OF 1.6 LB/FT³ POLYURETHANE FOAM

Difference Between	t	Significance Level
0"-1/2"	0.70	0.50
0"-1"	0.47	0.70
0"-1-1/2"	1.09	0.30
0"-2"	2.68	0.02
0"-3"	2.789	0.01
0"-4"	3.368	0.01

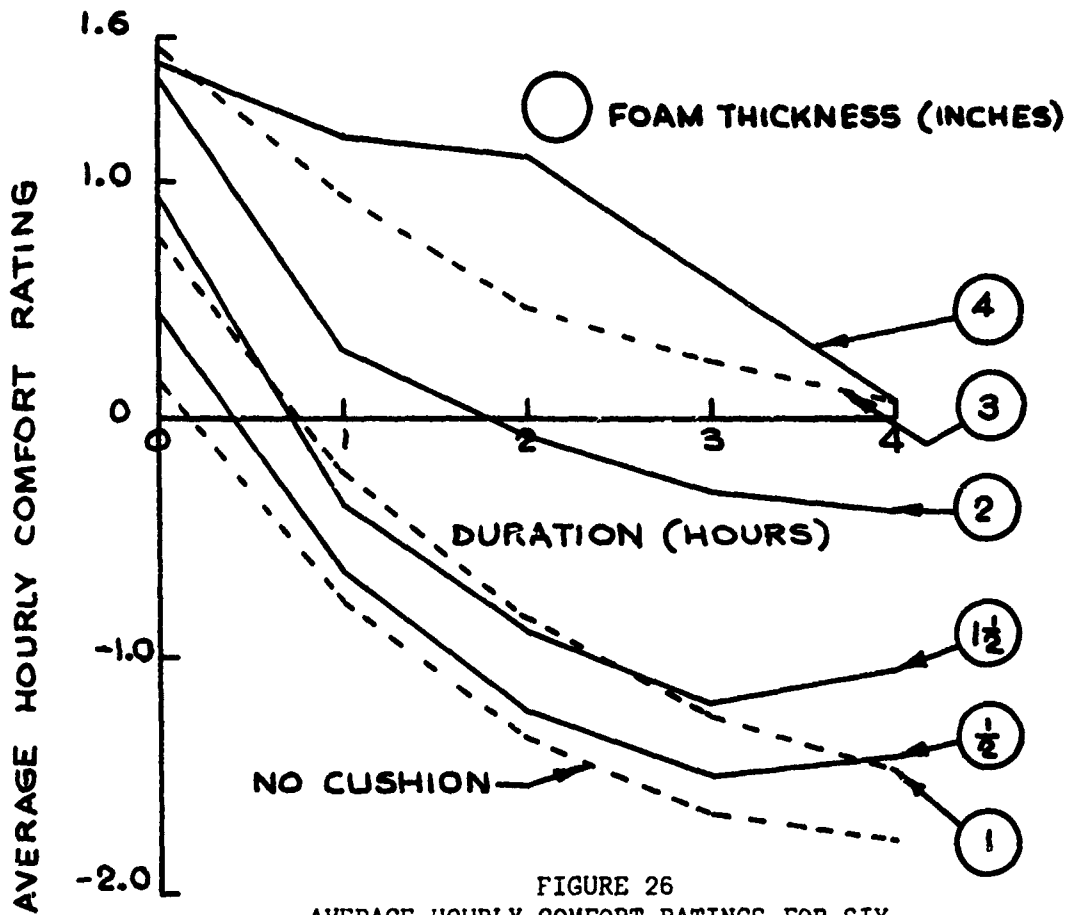

FIGURE 26
AVERAGE HOURLY COMFORT RATINGS FOR SIX THICKNESSES OF 1.6 LB/FT³ POLYURETHANE FOAM

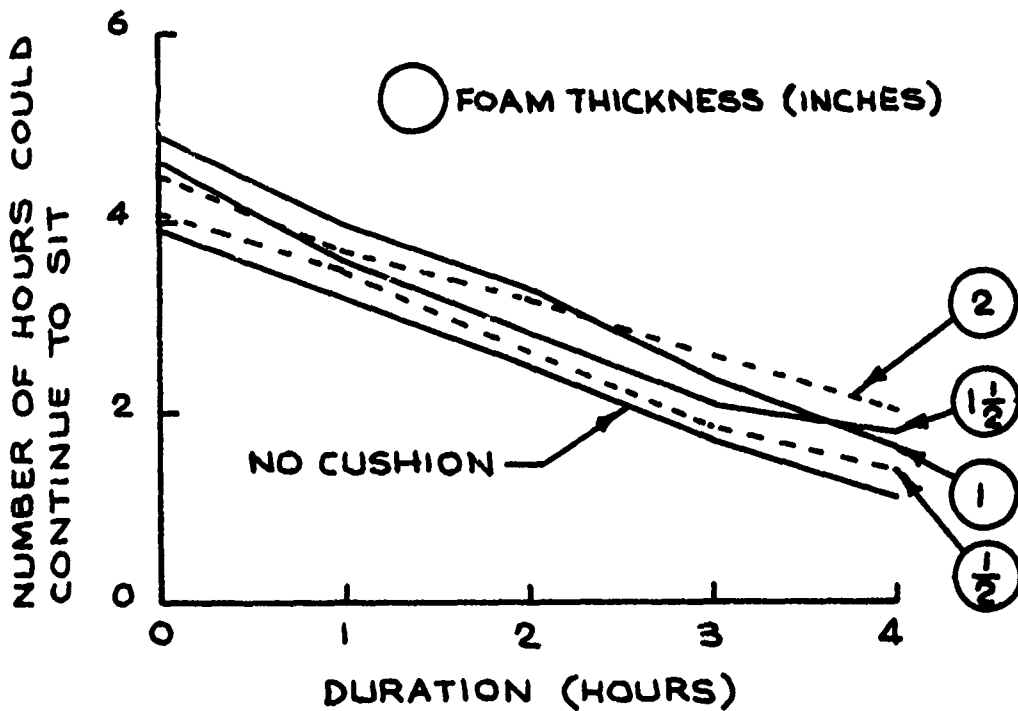

FIGURE 27
THE NUMBER OF HOURS SUBJECTS ESTIMATED THEY COULD CONTINUE TO SIT FOR FOUR THICKNESSES OF 1.6 LB/FT³ POLYURETHANE FOAM

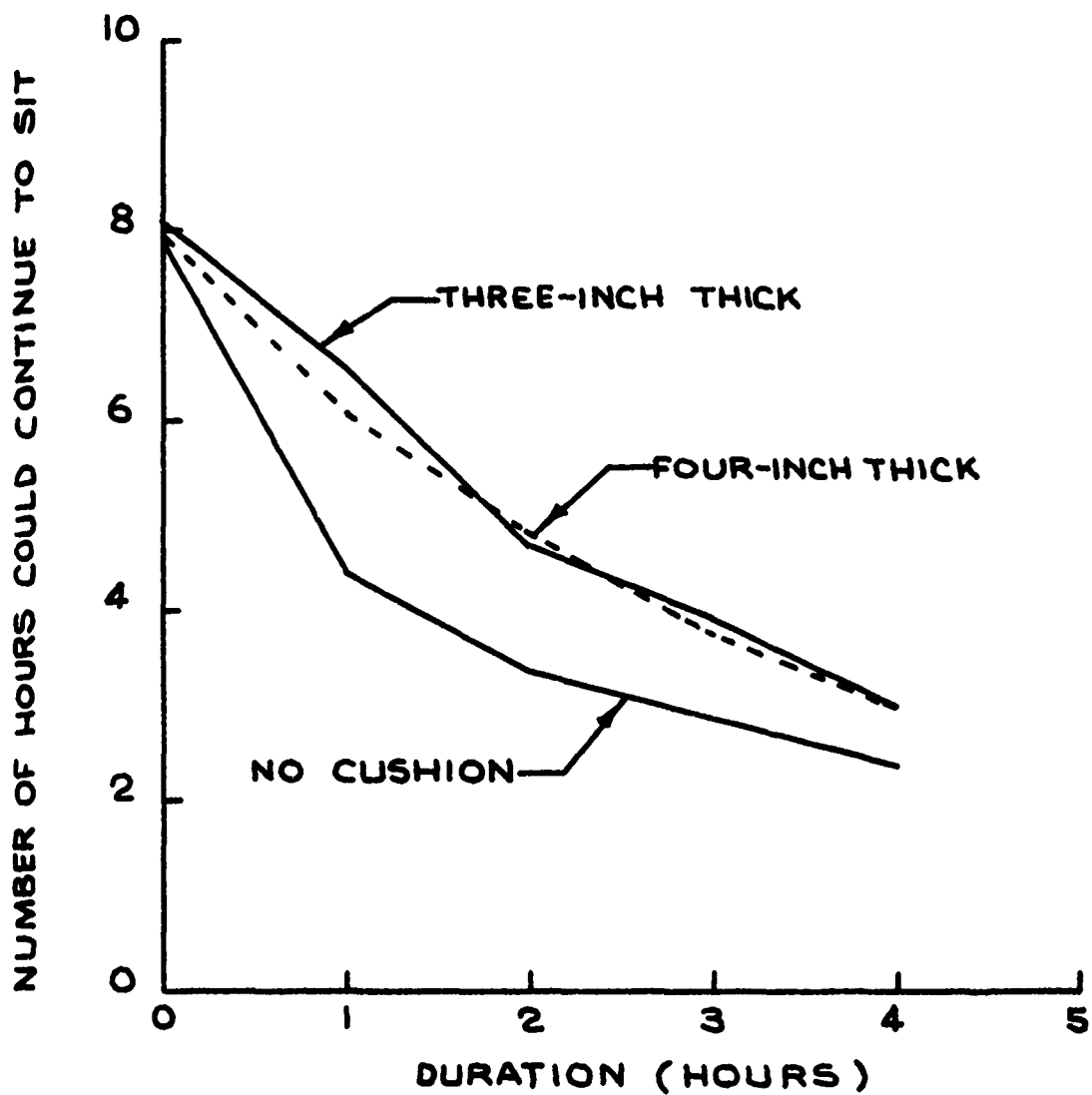

FIGURE 28
THE NUMBER OF HOURS SUBJECTS ESTIMATED THEY COULD CONTINUE
TO SIT FOR TWO THICKNESSES OF 1.6 LB/FT³ POLYURETHANE FOAM

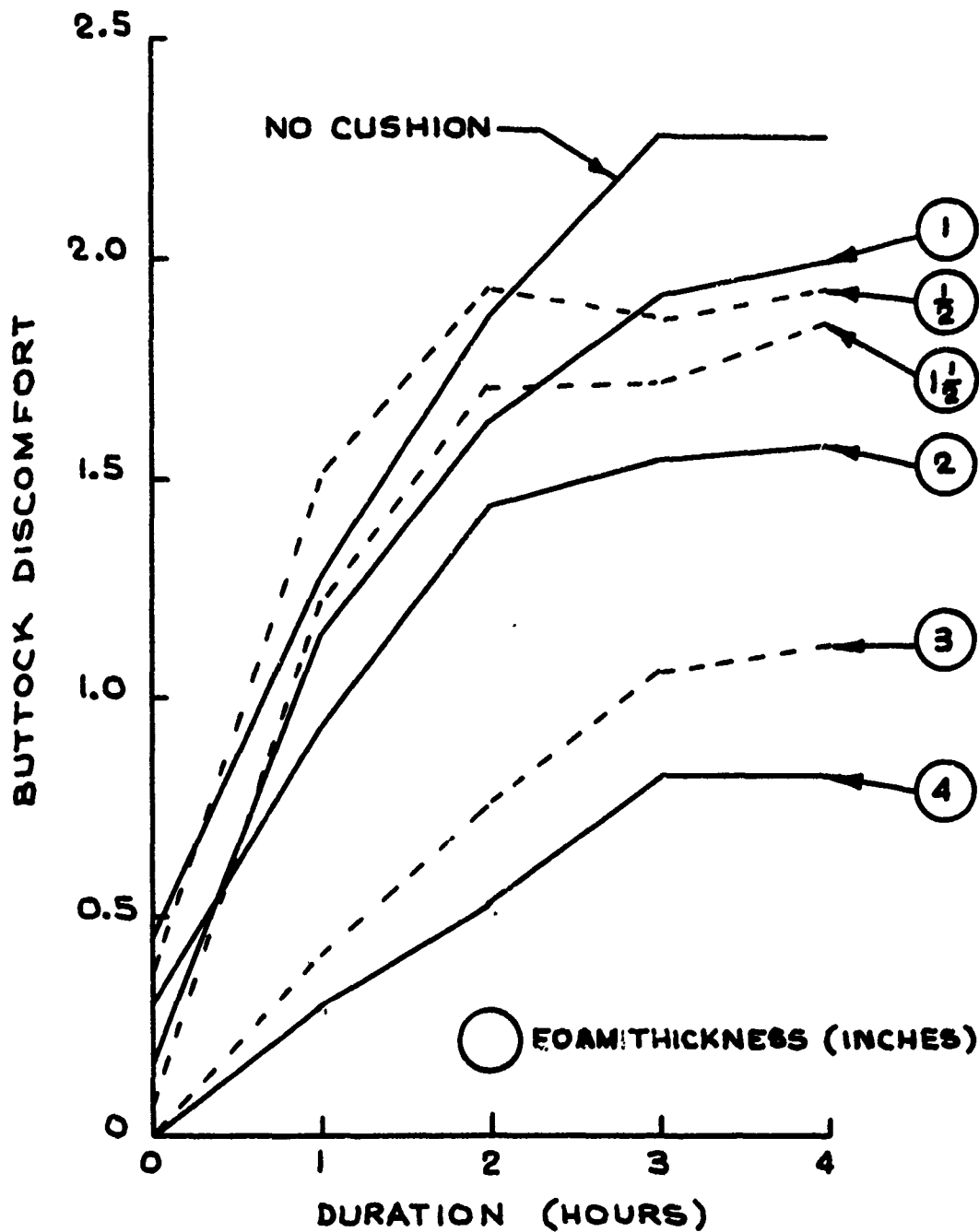

FIGURE 29
AVERAGE HOURLY BUTTOCK DISCOMFORT FOR
SIX THICKNESSES OF 1.6 LB/FT³ POLYURETHANE FOAM

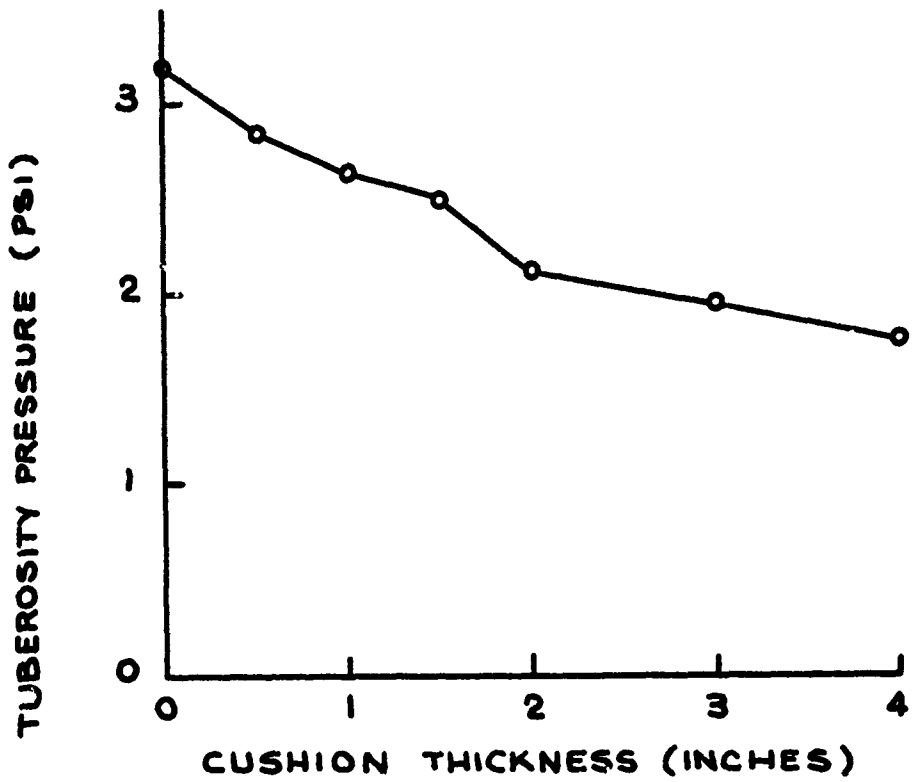

FIGURE 30
TUBEROSITY PRESSURE AS A FUNCTION OF
CUSHION THICKNESS FOR 1.6 LB/FT³ POLYURETHANE FOAM

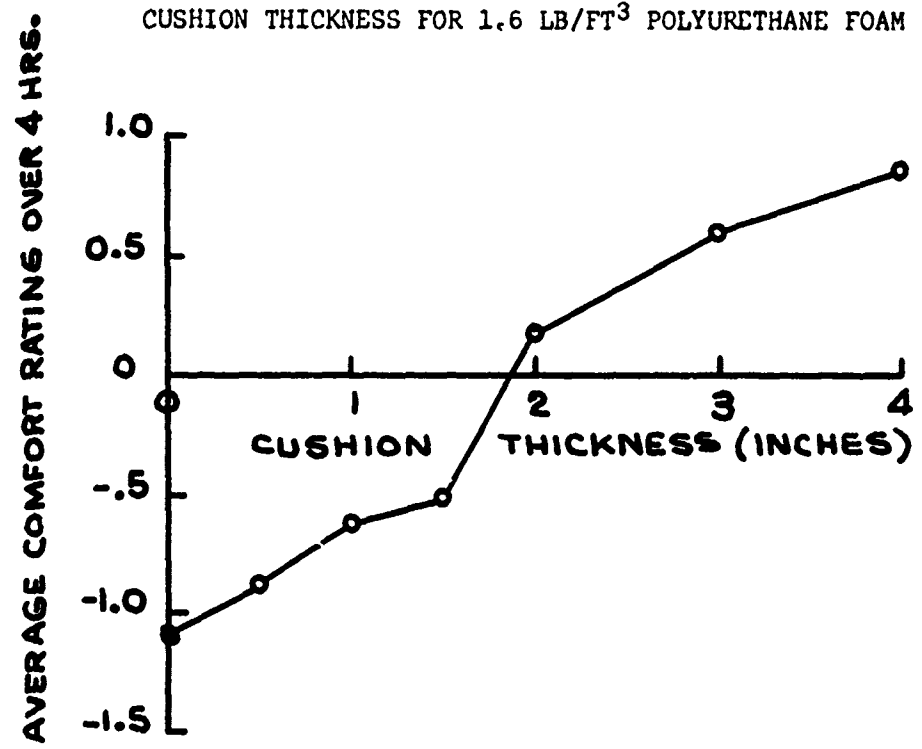

FIGURE 31
AVERAGE HOURLY COMFORT RATING AS A FUNCTION OF
CUSHION THICKNESS FOR 1.6 LB/FT³ POLYURETHANE FOAM

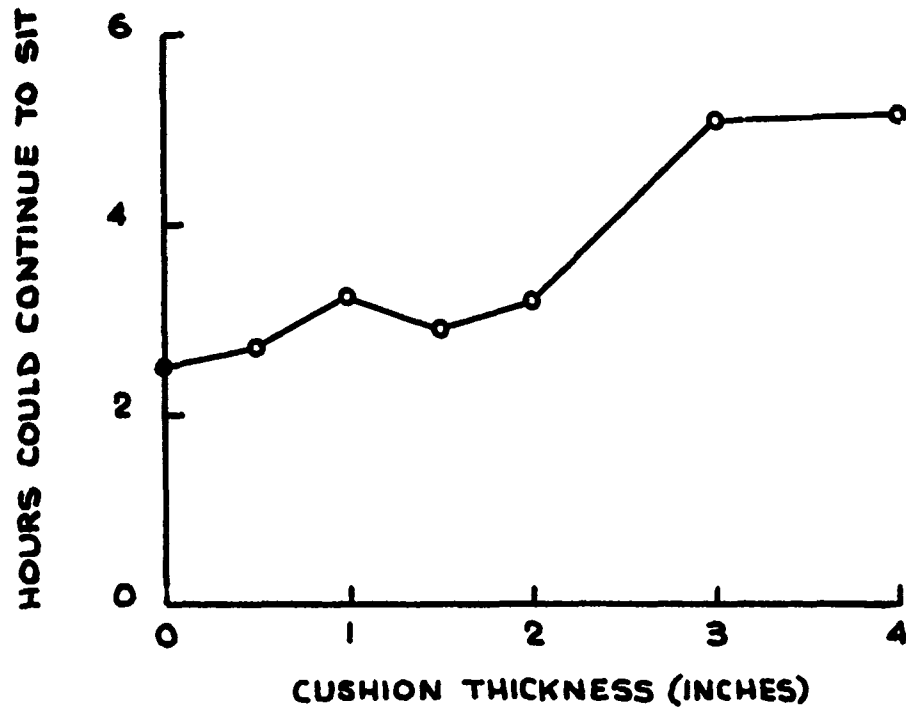

FIGURE 32
NUMBER OF HOURS SUBJECTS ESTIMATED THEY COULD CONTINUE TO SIT AS A FUNCTION OF THICKNESS FOR 1.6 LB/FT³ POLYURETHANE FOAM

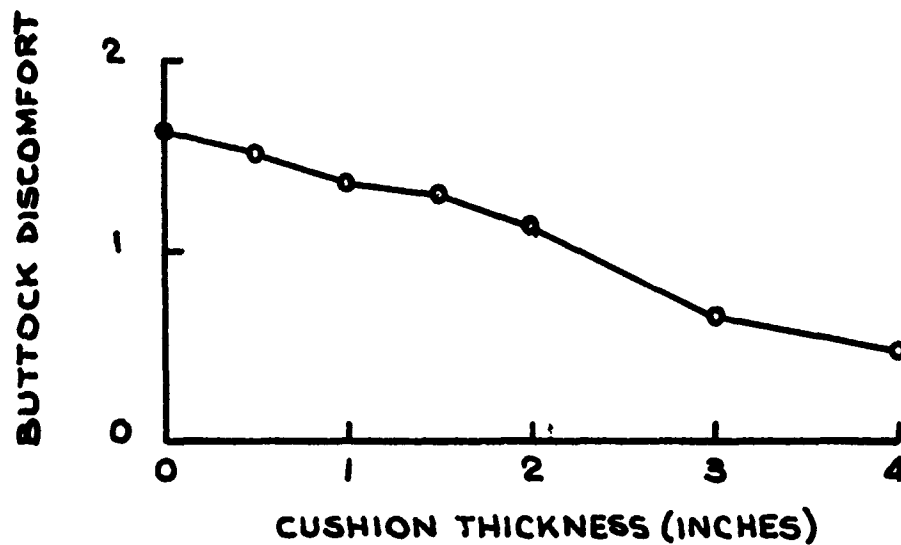

FIGURE 33
BUTTOCK DISCOMFORT FOR SIX THICKNESSES OF 1.6 LB/FT³ POLYURETHANE FOAM

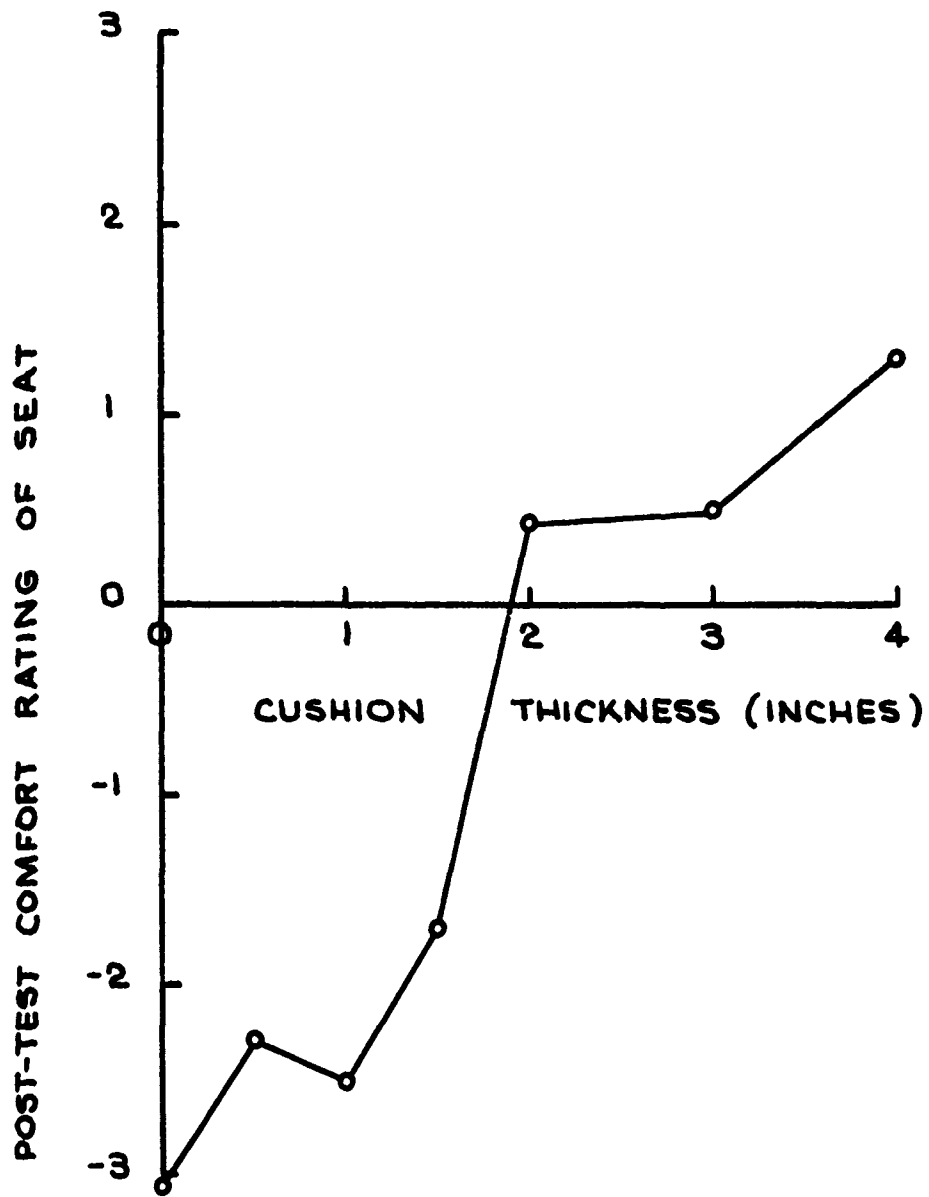

FIGURE 34
THE POST-TEST COMFORT RATING OF THE SEAT
FOR SIX THICKNESSES OF 1.6 LB/FT³ POLYURETHANE FOAM

STATIC LOAD-DEFLECTION TESTS

Static load-deflection tests for the polyurethane foam were conducted in accordance with MIL-S-27332A (USAF) test procedures. The tests were performed with the hydraulic loading device illustrated in Appendix B, and the flat 50-sq. inch indenter foot, the ellipsoidal indenter foot, and the double ellipsoid indenter foot were used.

The specimens tested in this portion of the program consisted of a thin slab of Ensolite with a thickness of polyurethane foam on top. This configuration was tested instead of simple polyurethane because it represented a closer approximation to the final design concept of both the active and passive cushion. A decision was made to keep the two types of cushions as similar as possible in their basic construction so that the two could be compared to each other in terms of the optimization procedures. The actual specimens consisted of 1/4", 1/2", 3/4", and 1" of Ensolite with 0", 1/2", and 1" layers of polyurethane. The load-deflection curves are shown in Figures 35, 36, and 37.

REBOUND RESILIENCE TESTS

In order to provide a realistic analysis of cushion dynamics on the analog computer, the damping ratio of 1.6 lb/ft³ polyurethane material was found by means of pendulum rebound resilience tests. Results are shown in Figure 38. An attempt was made to obtain damping data on the Ensolite material, but its stiffness was such that no useful data could be obtained on the rebound pendulum.

OPTIMIZATION OF THE PASSIVE CUSHION

The ultimate goal of the program reported here was the optimization of a cushion utilizing the procedures outlined earlier. Analog computer results for the four thicknesses of Ensolite with no polyurethane foam and with 1/2" and 1" of foam are shown in Figure 39. These data represent dynamic response values for a single degree-of-freedom system with a 60 lb. upper torso mass, a point which will be dealt with shortly.

In Figure 40, the probability of compression fracture is shown as a function of Ensolite thickness and the presence or absence of a polyurethane foam layer. The polyurethane foam has an attenuating effect with the thicker Ensolite layers which also involve higher probability of injury values. An important feature of Figure 40 should be noted. The injury probability values rise quite rapidly over the range from 3/4" to 1" of Ensolite indicating a critical point, almost a discontinuity from a practical view, in the cushion thickness versus injury risk relationship.

The probability of compression fracture and probability of significantly increased comfort are plotted in Figure 41. In order to provide an optimization curve that illustrates the points to be made later, the probability

of compression fracture values were multiplied by ten. Note should also be taken of the fact that the horizontal coordinate represents polyurethane thickness rather than Ensolite thickness. The Ensolite used in this design was quite stiff and, as a consequence, was assumed to have a minimal effect on increasing comfort. It was used to provide a firm mechanical support for the upper layer of foam and as a method of incorporating the contouring required for the seat pan, a point discussed more fully below.

In Figure 41, the injury probability subtracted from the comfort enhancement probability shows an optimum polyurethane thickness of one inch. The injury probability curve has been extrapolated rather arbitrarily beyond one inch of polyurethane; however, the slope of the extrapolated segment is not critical as long as it is positive. Since the comfort enhancement probability becomes practically asymptotic with one inch of foam, the optimum point must be a one-inch thickness if the injury probability continues to increase. Using the definition of optimization adopted in this program, the optimum cushion thickness is defined by the asymptote of the comfort enhancement probability curve as long as the injury probability increases with increasing thickness. Therefore, very precise injury probability estimates are not required for optimization.

The last point is rather important. In the analog computer analysis of cushion dynamic response, a 60-pound mass, single degree-of-freedom model of the human body was used. One of the findings of the analysis was that the relationship of the initial or one G point on the load-deflection curve to the "knee" of the curve was important in providing attenuation or amplification. The problem is that the cushions were preloaded to 60 pounds under one G in the computer but the buttock-cushion interface study showed the effective load to be 120-130 pounds for the average occupant. Furthermore, the human body and cushion are more accurately represented by the model in Figure 42. These limitations on the dynamic responses data are not serious, however, as long as the increasing probability of injury assumption holds.

Several features of the optimization procedure should be considered in detail in order to evaluate the adequacy of the method. Most importantly, the absolute value of the probability of injury should be quite low at the optimum point. For example, the optimum thickness could be two inches of foam for a given cushion design but the probability of a compression fracture might be as high as 30% or 40%. The optimum in such a case is unacceptable in terms of injury risk. In any optimization program, therefore, there is a need to establish a maximum acceptable injury risk, and the optimum cushion should not exceed that limit.

The other facet of the procedure which should be noted is the relative nature of the comfort enhancement probability. A review of the comfort ratings graph shows that the subjective evaluation of increasing comfort does not become asymptotic at one inch of foam. In Figure 41, the optimization was carried out relative to no cushion at all. Figure 43 shows another situation entirely. The probability of comfort enhancement is calculated and plotted relative to the comfort provided by one inch of

foam using actual comfort test data. A purely hypothetical probability of injury curve is used for illustration. In this example, there are two optimum points. One occurs at or below one inch of foam and represents a "safe but uncomfortable" design. The other occurs at three inches and constitutes an "unsafe but very comfortable" design. A worst case condition occurs with two inches of foam, shown by the negative peak of the optimization curve.

In the kind of situation just described, the cushion designer has two options. First and most preferable would be an attempt to generate a new and different cushion design with better comfort versus risk characteristics. If such a course of action is not possible, the alternative is to adopt a maximum acceptable injury risk, for example the 25% level shown in Figure 43, and take all the comfort enhancement available at that risk level.

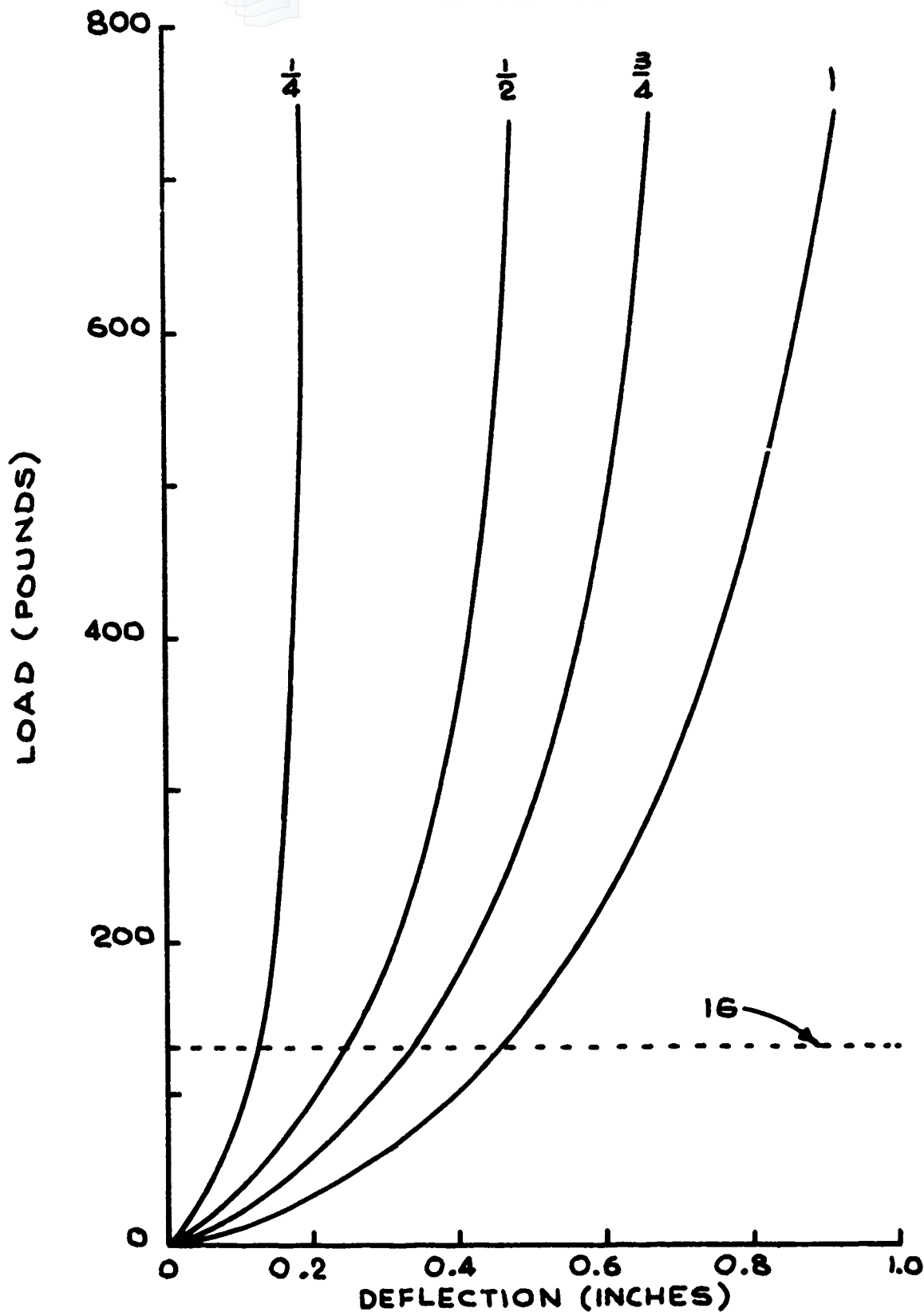

FIGURE 35
LOAD-DEFLECTION CURVES FOR
ENSOLITE WITH NO POLYURETHANE FOAM

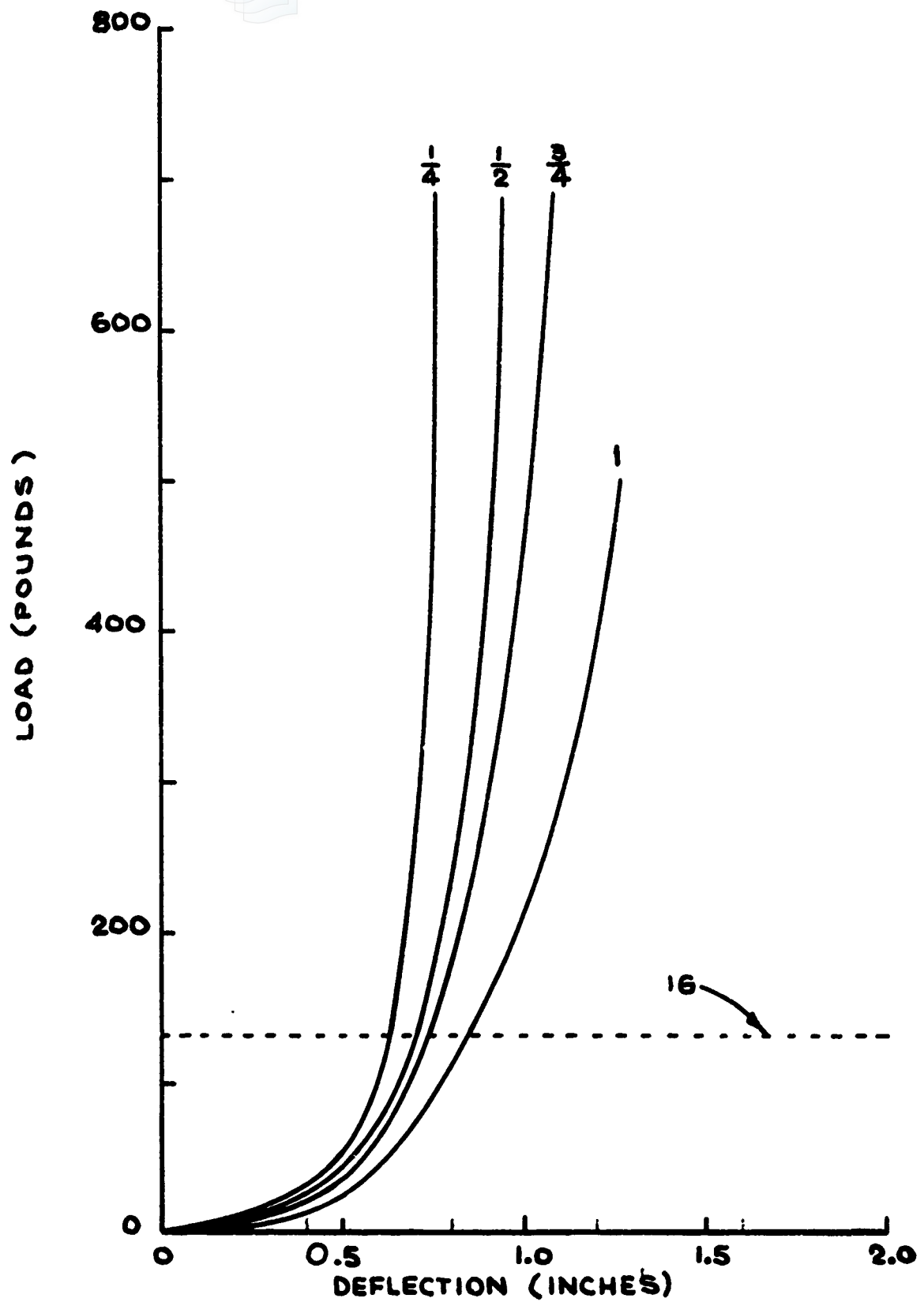

FIGURE 36
LOAD-DEFLECTION CURVES FOR
ENSOLITE WITH 1/2-INCH OF POLYURETHANE FOAM

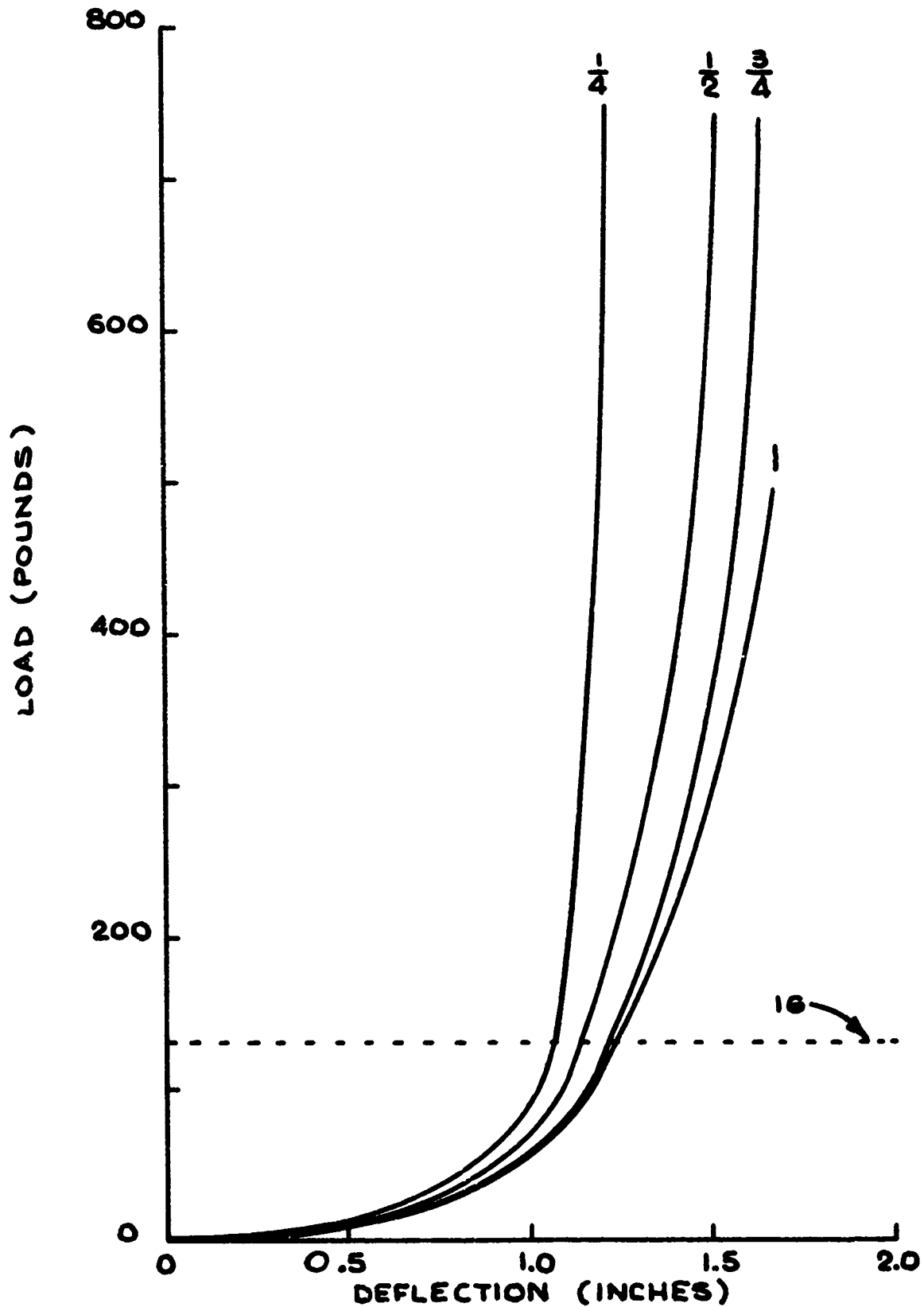

FIGURE 37
LOAD-DEFLECTION CURVES FOR
ENSOLITE WITH 1-INCH OF POLYURETHANE FOAM

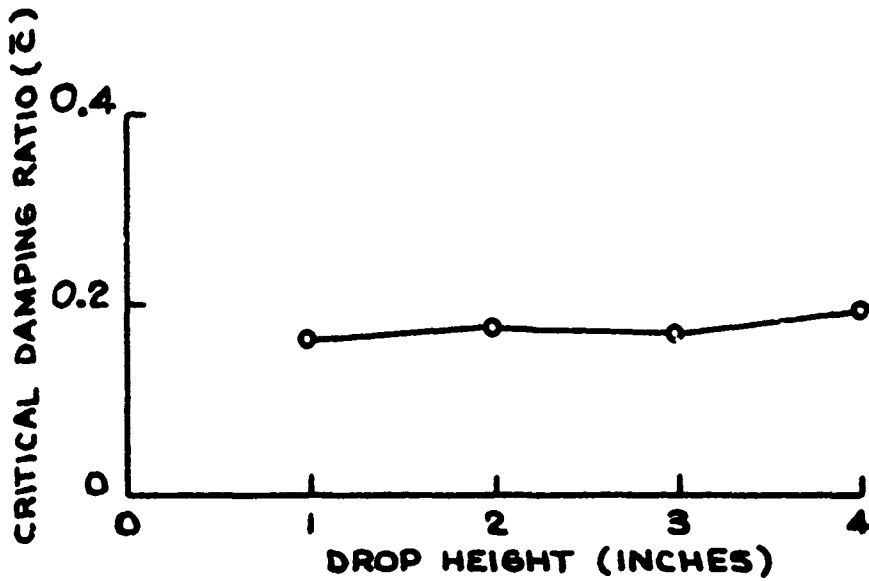

FIGURE 38
CRITICAL DAMPING RATIO VALUES FOR 1-INCH
THICK 1.6 LB/FT³ POLYURETHANE FOAM

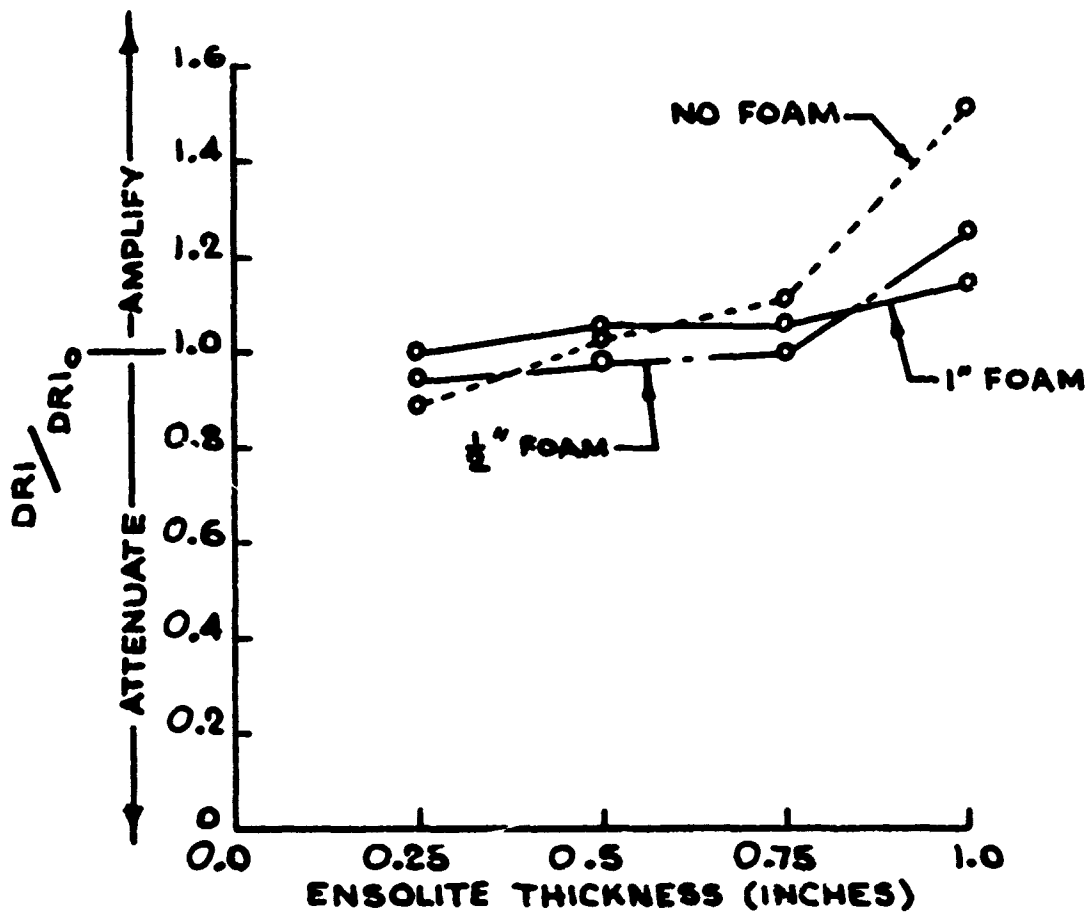

FIGURE 39
ANALOG COMPUTER RESULTS

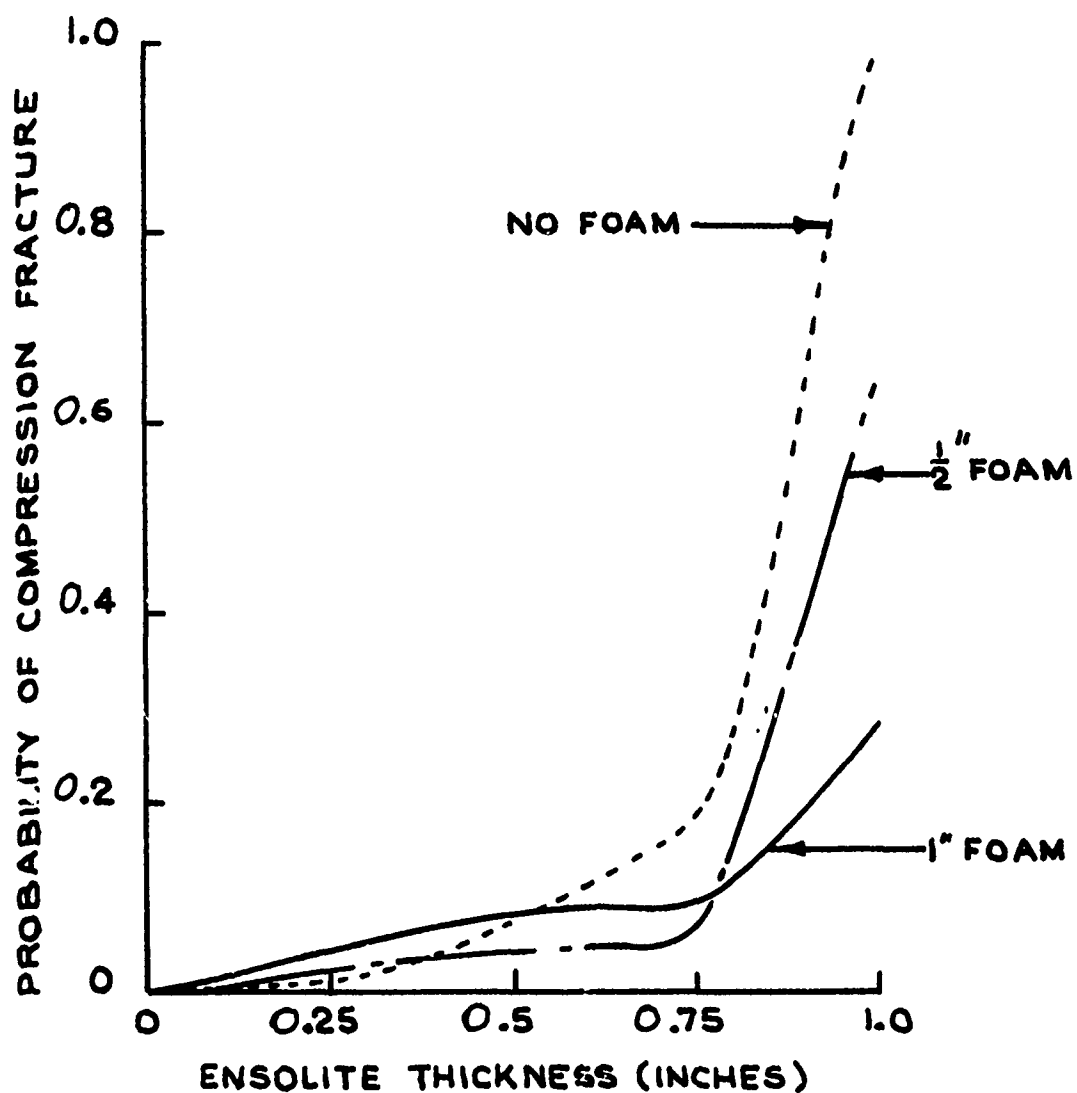

FIGURE 40
INJURY RISK (COMPRESSION FRACTURE ONLY) FOR
THE PASSIVE CUSHION CONFIGURATION TESTED

SECTION V

DEVELOPMENT OF AN INFLATABLE CUSHION

DISCUSSION

An inflatable seat cushion has one major advantage over a passive cushion: it can be designed to provide low tuberosity pressures during normal l-g operations and yet become rigid during ejection. Comfort over long durations is feasible without compromising seat ejection safety. This combination of comfort and safety was the goal of the inflatable seat cushion development.

PRELIMINARY DEVELOPMENT TESTS

Two approaches to an inflatable cushion were visualized at the beginning of the program. The first approach was the use of a non-extensible cushion inflated to a comfortable position during normal flight and then over-inflated to provide a rigid surface during ejection. The alternate approach required deflation of an extensible rubber bag prior to ejection. A sub-contract was let to Hauser Research and Engineering Company for the preliminary development of both non-extensible and extensible seat cushions.

A non-extensible seat cushion was developed by Hauser Research and Engineering, the method of construction involved wrapping a high strength plastic shipping tape around a block of styrofoam and then chemically washing the styrofoam away. Automobile tire fittings were incorporated in the bag after the initial fabrication for inflation and deflation.

The non-extensible cushion was used for preliminary tuberosity pressure measurements with Frost Engineering personnel acting as subjects. The inflation pressure versus tuberosity pressure curve for the cushion with and without a covering polyurethane foam layer is shown in Figure 45. Without foam, the cushion exhibits a very sharp drop in tuberosity pressure between 0.6 and 0.7 psi inflation pressure. Beyond this critical point, the tuberosity pressure begins to increase again as the cushion balloons out. The tuberosity pressure with one inch of 1.6 lb/ft³ polyurethane foam placed on top of the cushion shows a drop of approximately 0.4 psi in tuberosity pressure. The foam serves to broaden the range of inflation pressures at which a minimum tuberosity pressure is obtained.

Several considerations resulted in the abandonment of the non-extensible cushion design. First, calculations showed that large pressures, on the order of 200 or 300 psi, would be required in order to make the bag stiff enough to prevent excessive ejection injuries. Second, pilots and crew members are notoriously leary of highly inflated items in the cockpit. Third, preliminary tests revealed a major problem in controlling leakage. As a result of these factors, the decision was made to proceed with an extensible cushion.

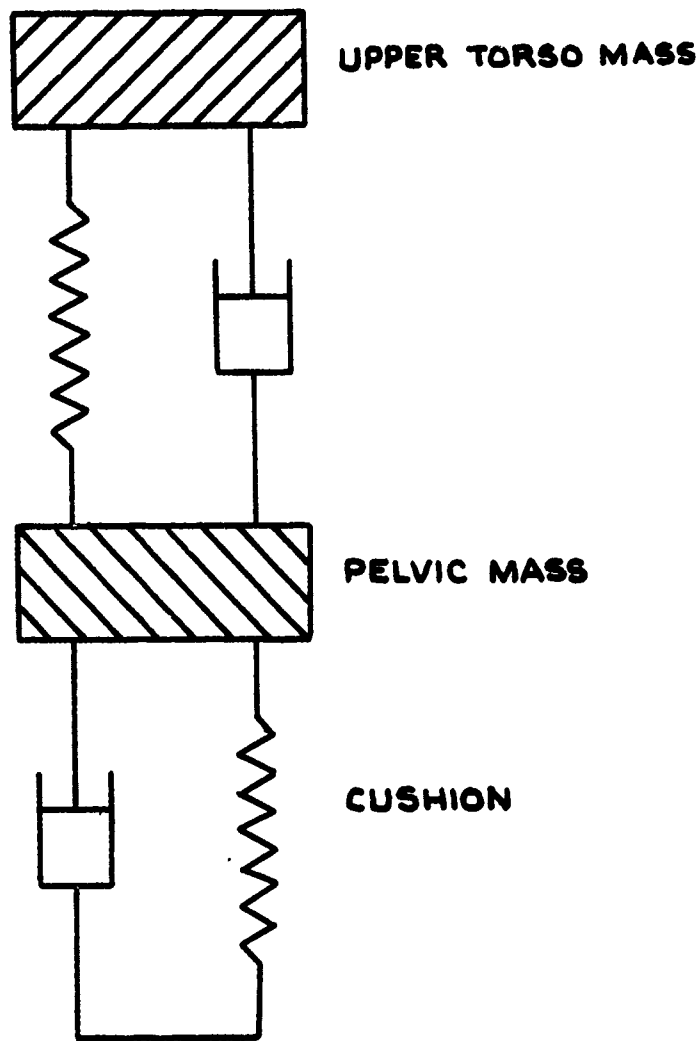

FIGURE 42
DOUBLE MASS MODEL OF THE
HUMAN BODY ON A SEAT CUSHION

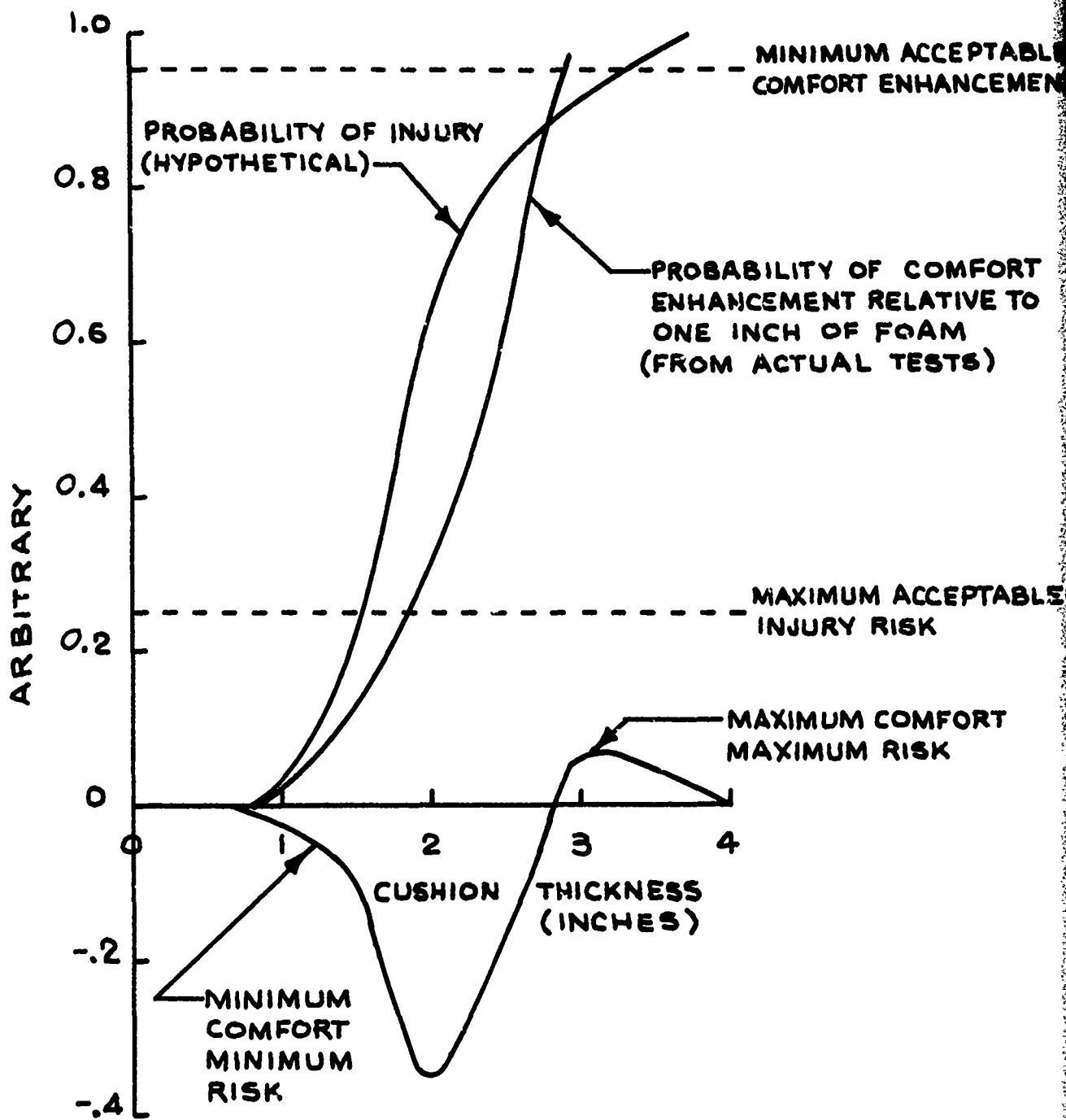

FIGURE 43
HYPOTHETICAL OPTIMIZATION SITUATION
ILLUSTRATING NO TRUE OPTIMUM

DESIGN OF THE OPTIMUM PASSIVE CUSHION

A sketch of the optimum passive cushion developed under this program is shown in Figure 44 including configuration, dimensions, and materials. The general configuration is that of the cushion for the F4C Martin-Baker Ejection Seat. As noted on the drawings, the cushion as fabricated consists of a very thin layer of high density, closed cell Ensolite foam under the one inch of polyurethane. The purpose of the high density material was to give the cushion some mechanical stability so that it would maintain its shape and position in the seat.

The underside of the cover is cotton duck material, while the top cover consists of a tubular Helenca stretch material which provides good air circulation and minimizes body heat and perspiration problems.

A comparison can be made of the combined comfort and hazards of the cushion developed in this program and the two operational Air Force cushions. As shown earlier, the comfort of the two Air Force operational seat cushions was significantly superior to two inches of 1.6 lb/ft³ polyurethane foam and roughly equivalent to four inches of the same foam. However, the injury probability rate for both Air Force operational seat cushions was estimated to be about 20% compared to 4% for the 1/4" Ensolite and 1" polyurethane foam cushion.* The two Air Force operational seat cushions, therefore, provide a reasonably high degree of comfort but at an apparent high price in terms of injury probabilities. The optimum cushion developed under the present program was designed to provide a much lower injury probability rate but with a consequent reduction in comfort.

The attempt to obtain an optimum passive seat cushion has brought into focus a major design dilemma. Comfort is related to the pressures applied to the ischial tuberosities, and the tuberosity pressure varies inversely with the thickness of a cushion. In general, however, the thicker a cushion becomes, the more dangerous it becomes. Therefore, any seat cushion which attempts to provide comfort and safety simultaneously must utilize a more sophisticated approach than simple variations in thickness and stiffness.

*NOTE: These injury probability levels are projections based on analog computer studies using the acceleration-time history of Figure 13 and do not represent actual injury frequency rates for the F101 or F104 airplanes.

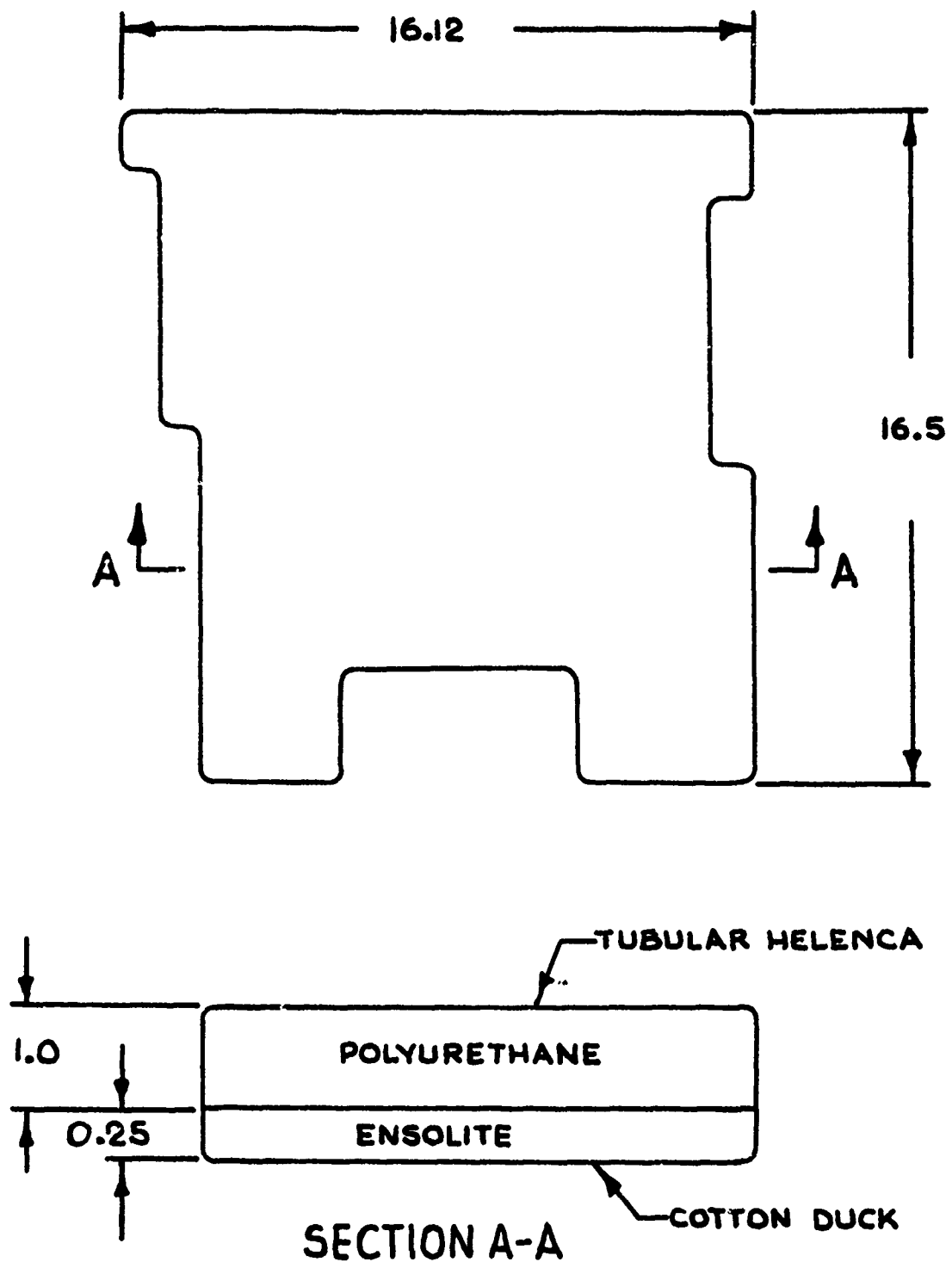

FIGURE 44
OPTIMUM PASSIVE CUSHION -
GENERAL ARRANGEMENT

SECTION V

DEVELOPMENT OF AN INFLATABLE CUSHION

DISCUSSION

An inflatable seat cushion has one major advantage over a passive cushion: it can be designed to provide low tuberosity pressures during normal 1-g operations and yet become rigid during ejection. Comfort over long durations is feasible without compromising seat ejection safety. This combination of comfort and safety was the goal of the inflatable seat cushion development.

PRELIMINARY DEVELOPMENT TESTS

Two approaches to an inflatable cushion were visualized at the beginning of the program. The first approach was the use of a non-extensible cushion inflated to a comfortable position during normal flight and then over-inflated to provide a rigid surface during ejection. The alternate approach required deflation of an extensible rubber bag prior to ejection. A sub-contract was let to Hauser Research and Engineering Company for the preliminary development of both non-extensible and extensible seat cushions.

A non-extensible seat cushion was developed by Hauser Research and Engineering, the method of construction involved wrapping a high strength plastic shipping tape around a block of styrofoam and then chemically washing the styrofoam away. Automobile tire fittings were incorporated in the bag after the initial fabrication for inflation and deflation.

The non-extensible cushion was used for preliminary tuberosity pressure measurements with Frost Engineering personnel acting as subjects. The inflation pressure versus tuberosity pressure curve for the cushion with and without a covering polyurethane foam layer is shown in Figure 45. Without foam, the cushion exhibits a very sharp drop in tuberosity pressure between 0.6 and 0.7 psi inflation pressure. Beyond this critical point, the tuberosity pressure begins to increase again as the cushion balloons out. The tuberosity pressure with one inch of 1.6 lb/ft³ polyurethane foam placed on top of the cushion shows a drop of approximately 0.4 psi in tuberosity pressure. The foam serves to broaden the range of inflation pressures at which a minimum tuberosity pressure is obtained.

Several considerations resulted in the abandonment of the non-extensible cushion design. First, calculations showed that large pressures, on the order of 200 or 300 psi, would be required in order to make the bag stiff enough to prevent excessive ejection injuries. Second, pilots and crew members are notoriously leary of highly inflated items in the cockpit. Third, preliminary tests revealed a major problem in controlling leakage. As a result of these factors, the decision was made to proceed with an extensible cushion.

A simple rubber bag was fabricated first, mainly to investigate material characteristics and to check tuberosity pressures. Using 1/16th inch thick neoprene coated fabric materials, the extensible bag provided a tuberosity pressure versus inflation pressure curve similar to that for the non-extensible cushion. As the cushion is inflated, the tuberosity pressure decreased until the bag lifted the tuberosities and buttocks off the seat pan. This lift-off characteristic resulted in an unstable feel to the cushion, roughly equivalent to that experienced when trying to sit on a partially inflated beach ball or basket ball.

In order to provide stability, the areas immediately below the tuberosities were glued down on a second version of the inflatable cushion. Tuberosity pressure tests run with this cushion gave the results shown in Figure 46 with a rather large drop in tuberosity pressure as inflation continued up to a maximum point. With one inch of 1.6 lb/ft³ polyurethane foam on the cushion, the overall change in pressure is less drastic as would be expected and the minimum tuberosity pressure zone is much broader, but within 0.13 psi of the inflated cushion pressure without the PUE. In terms of thickness of PUE, that is equivalent to 0.18" (Figure 30) for tuberosity pressures in excess of 3 psi.

Even though tuberosity pressure data were encouraging, problems were encountered with seam leakage. The lowest pressure corresponds to 0.65" of PUE (Figure 30) which has in the neighborhood of a 50/50 chance of being more comfortable than no cushion at all. (Tables IV to VI). The possibility of improving the characteristics of the cushion by using thinner rubber materials also had to be investigated. Therefore, the configuration shown in Figure 47 was developed by Frost Engineering personnel for further testing. Leakage problems were minimized by wrapping the inflatable rubber member around a piece of Ensolite stiffened by an aluminum plate glued to the bottom. This configuration, shown in Figure 47, was subjected to comfort tests, load-deflection tests and inflation/deflation tests.

COMFORT TESTS OF THE INFLATABLE CUSHION

The comfort test procedure for the inflatable cushion was the same as that for the passive cushions. Instead of a variation in cushion thickness, the inflatable cushion tests were run with different amounts of inflation pressure. Commercial regulators and sensitive pressure gauges were incorporated on the back of the test seats for these tests with a small compressor and air tank used as the inflation air supply. The four seats were manifolded together to the air supply and any seat could be used for any condition since the cushion on each seat inflated to a pressure independent of the cushions on the other seats. The experimenter had the subject place himself on the cushion and adjust the shoulder harness and lap belt as for the passive cushion tests. Only after the subject was completely settled in the seat was the cushion inflated using the controls on the back of the seat, which the subjects were unable to see at any time during the test. The experimenters inflated the cushions to 20, 30, 40 and 50 millimeters of mercury for the test conditions. Each subject also sat on the inflatable cushion with no inflation pressure, which was the equivalent of a rigid seat pan.

Table VII compares the overall degree of comfort, degree of discomfort in the buttocks, and post-test overall comfort ratings of the zero thickness cushion condition during the passive cushion and inflatable series. The overall degree of comfort ratings and the post-test ratings are similar for both subject panels, t-tests of the difference between the main ratings indicating no statistical significance in the differences. On the buttock discomfort ratings scale, the subject panel for the inflatable cushions consistently rated the hard seat as less comfortable than the panel in the equivalent passive cushion condition.

The mixed results of comparing the two subject panels for the two cushion conditions makes direct comparison between the types of cushions problematical. However, the results for the inflatable cushion can be analyzed in much the same manner as the results for the passive cushion in the preceding sections.

In Figures 48, 49, 50, and 51, the relationship of the various comfort and discomfort ratings to time are shown. The trends are in the same general direction as for the polyurethane foams, but the degree of shift in some cases is not as large as for the foams. The relationship of the ratings to inflation pressure are shown in Figures 51, 52, 53, and 54.

Table VIII shows the frequency of complaints during hourly evaluations for the inflatable seat cushion at different inflation pressures. The "too firm" complaint decreases steadily as the inflation pressure decreases as does the complaint of excessive pressure on the buttocks.

Tables IX, X, XI, and XII show the statistical significance of the difference in the various ratings for the different inflation pressures. Only one rating, the overall comfort rating at each hour, achieves a significance level better than 5%.

The buttock discomfort, overall comfort, final rating, and number of hours the subjects thought they could continue to sit are compared for the inflatable cushion and a two-inch slab of foam in Table XIII. These data show that the inflatable cushion was at least as comfortable as two inches of polyurethane and, in terms of buttock discomfort, probably better.

Table XIV presents a comparison of the Air Force operational seat cushions with the inflatable cushion at maximum pressure. The comparisons indicate a significant difference in the overall comfort ratings and of the final post-test ratings. These data show the operational cushions to be more comfortable, and the differences are significant at the 5% level or better. However, for the rating of buttock discomfort, the differences are non-significant statistically.

It is important to compare the relationship shown in Table XIV with the previous data, shown in Table VII, relating the degree of comfort, degree of discomfort of the buttocks, and post-tests rating for the uninflated and zero-thickness cushions. In the preceding comparisons, there was no significant difference in the degree of comfort or post-test

rating between subject panels, while those two scales are significantly different for the maximum inflation pressure versus the Air Force operational seat cushions. Conversely, the degree of discomfort in the buttocks was significantly lower in the no-cushion comparison but were non-significant in comparisons of the fully inflated cushion to the operational seat cushion. These results, which seem peculiar at first glance, can be explained by the differences between an inflatable and a passive cushion. Subjective impressions of the amount of pressure relief on the tuberosities plus the preliminary development test measurements of tuberosity pressure versus inflation pressure indicate the inflatable cushion is as efficient as a polyurethane foam cushion in terms of relieving tuberosity pressures. It is not surprising that no significant difference is shown between the Air Force operational seat cushions and the inflatable cushions in terms of buttock discomfort even though the inflatable cushion subject panel would have been expected to rate the inflatable cushion as more uncomfortable based upon the comparisons for no cushion at all. The inflatable cushion has a peculiar, unnatural feel, however, which is commented upon by almost everyone who sits on it. The probability is quite high that this peculiar "goosey" feel is the reason for the significantly lower overall comfort ratings and lower post-test questionnaire ratings of the inflatable cushion compared to the Air Force operational types. These results show that the inflatable cushion is probably as good as a foam cushion in the sense of buttock discomfort with one question left unresolved. Since most people are accustomed to sitting on foam or similar materials, the apparent overall differences in comfort ratings between the inflatable cushion and the foam cushion may be due to simply a lack of adjustment to and familiarity with an inflatable cushion. Whether the initial impression of this type can be overcome by repeated exposure could not be answered in the present development program.

Due to scheduling and test panel size limitations, the inflatable cushion was not comfort tested in the cycling or active mode of operation (active cushion). As described below, an inflation unit was designed to cycle the cushion with control over the frequency of cycling, the inflation-deflation duty cycle, and the rate of inflation and deflation. Due to the number of possible combinations of variables, a complete test program investigating the parameters systematically was deemed impractical for the development effort, and testing was restricted to the static inflation pressure against comfort comparisons presented above.

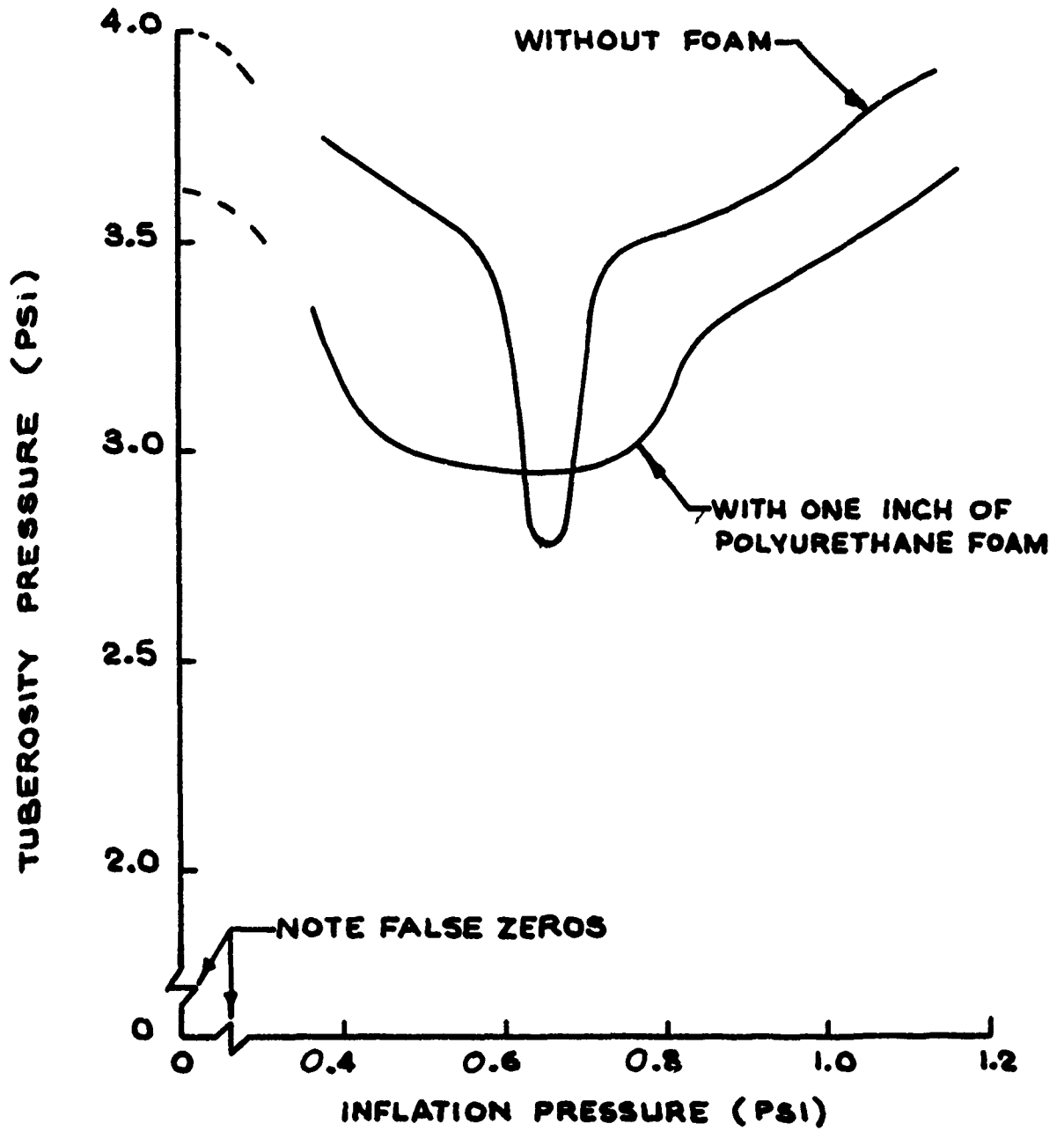

FIGURE 45
NONEXTENSIBLE 2-INCH
SIDEWALL INFLATABLE CUSHION

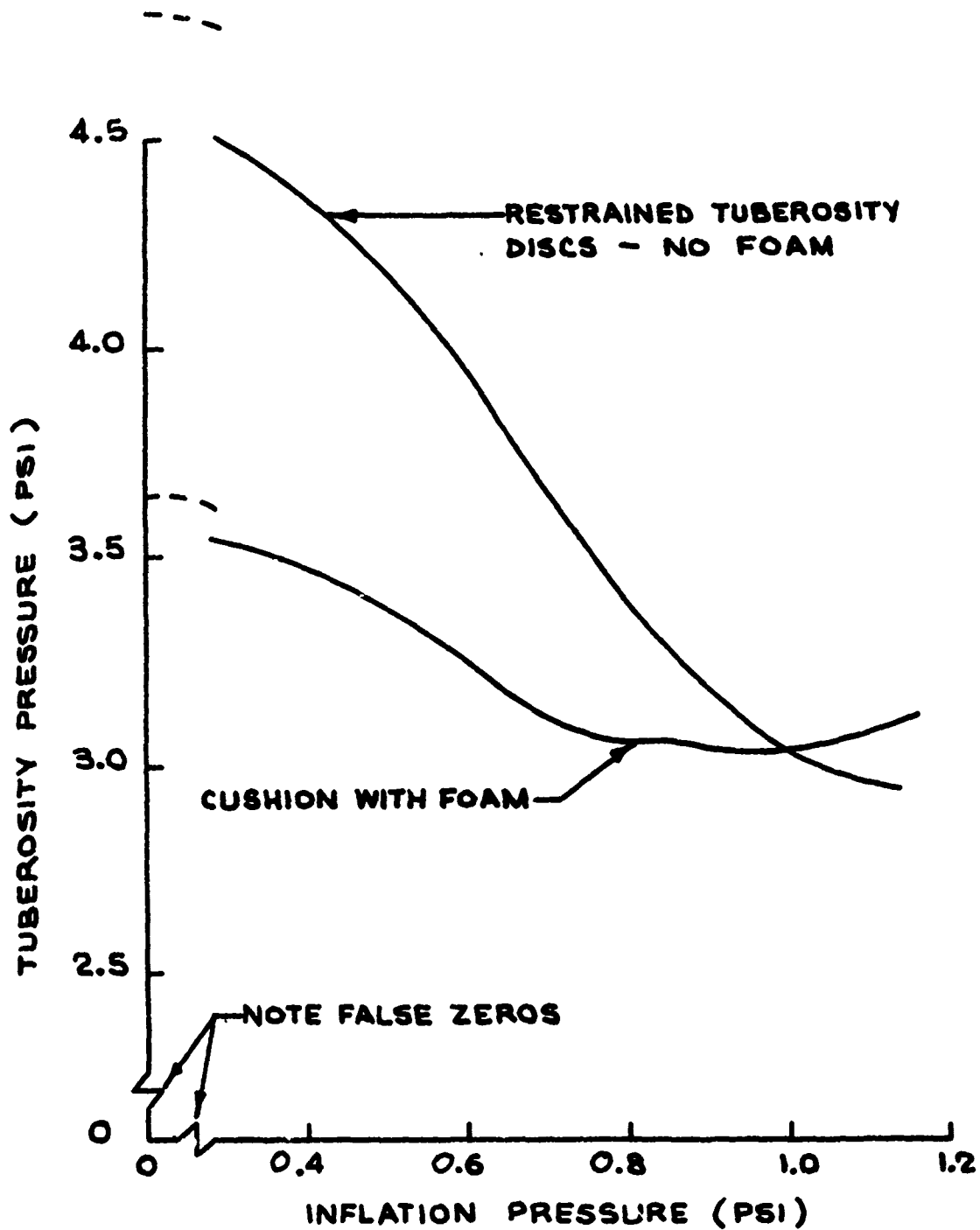

FIGURE 46
EXTENSIBLE INFLATABLE CUSHION

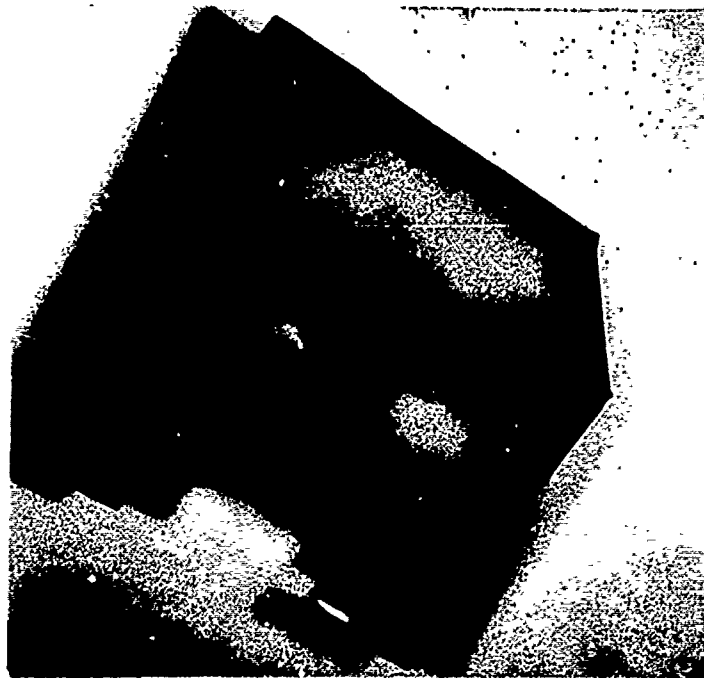

FIGURE 47
INFLATABLE CUSHION CONFIGURATION
DEVELOPMENT TESTING

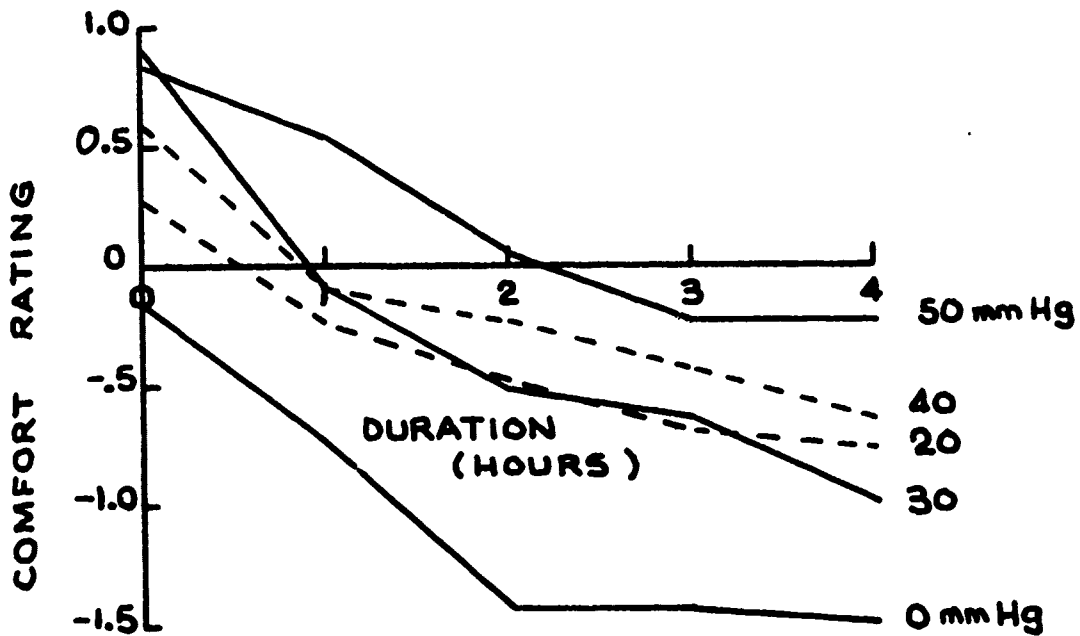

FIGURE 48
AVERAGE HOURLY COMFORT RATING FOR FOUR
INFLATION PRESSURES FOR AN INFLATABLE SEAT CUSHION

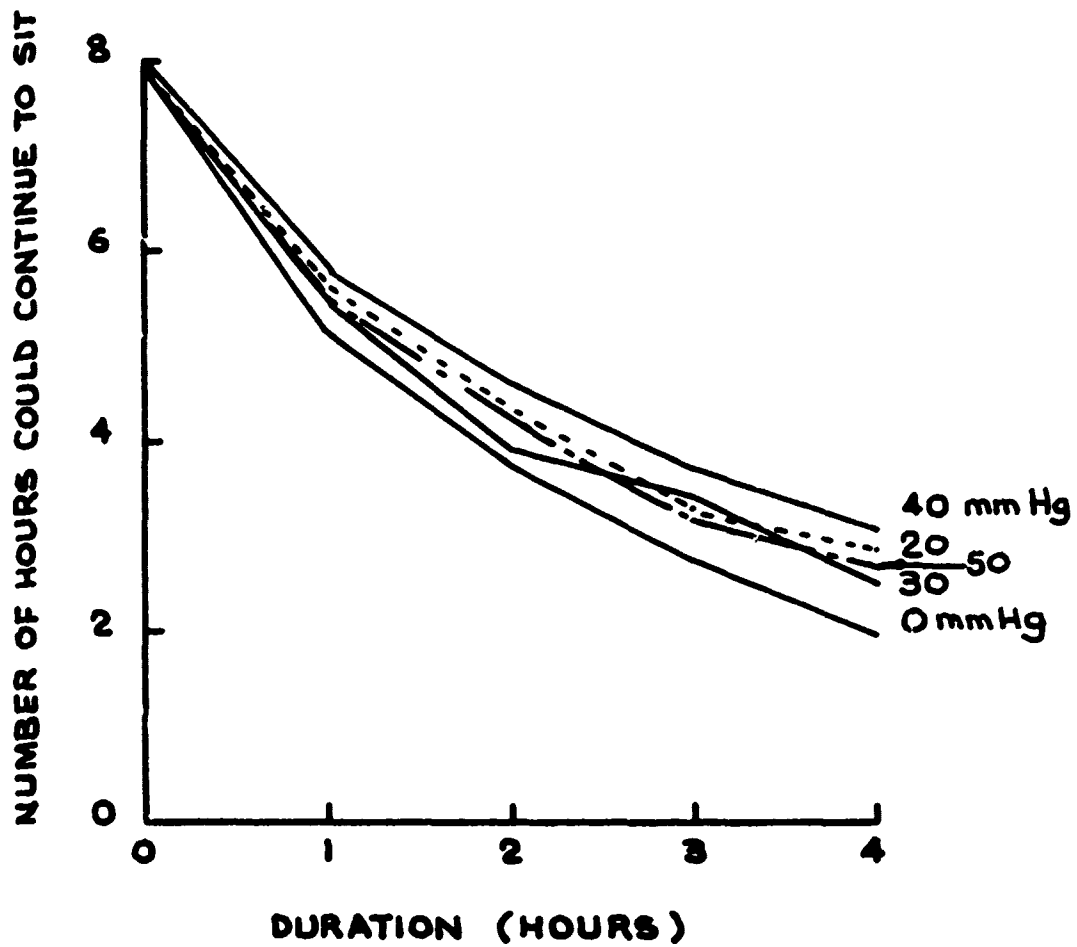

FIGURE 49
NUMBER OF HOURS SUBJECTS ESTIMATED THEY COULD
CONTINUE TO SIT FOR FOUR INFLATION
PRESSURES FOR AN INFLATABLE SEAT CUSHION

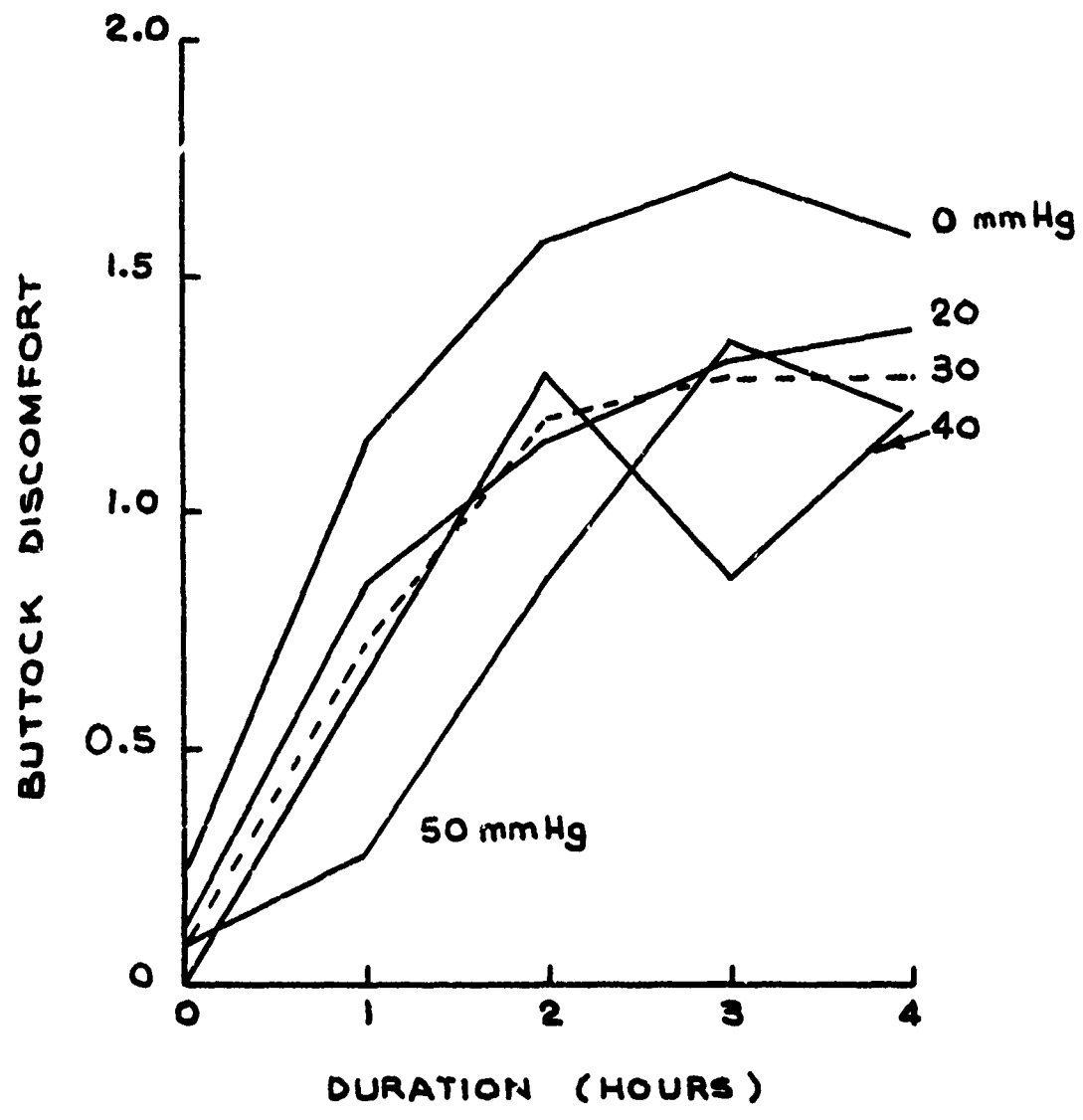

FIGURE 50
AVERAGE HOURLY BUTTOCK DISCOMFORT FOR FOUR
INFLATION PRESSURES FOR AN INFLATABLE SEAT CUSHION

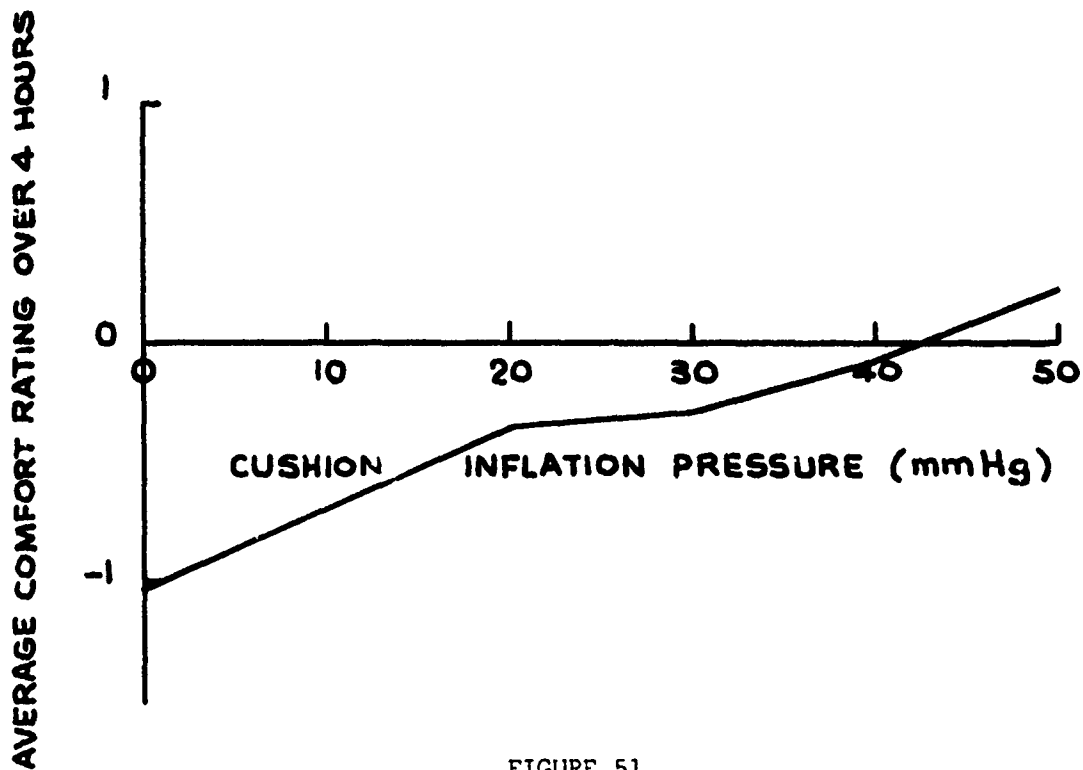

FIGURE 51
AVERAGE COMFORT RATING AS A FUNCTION OF
CUSHION INFLATION PRESSURE FOR AN INFLATABLE SEAT CUSHION

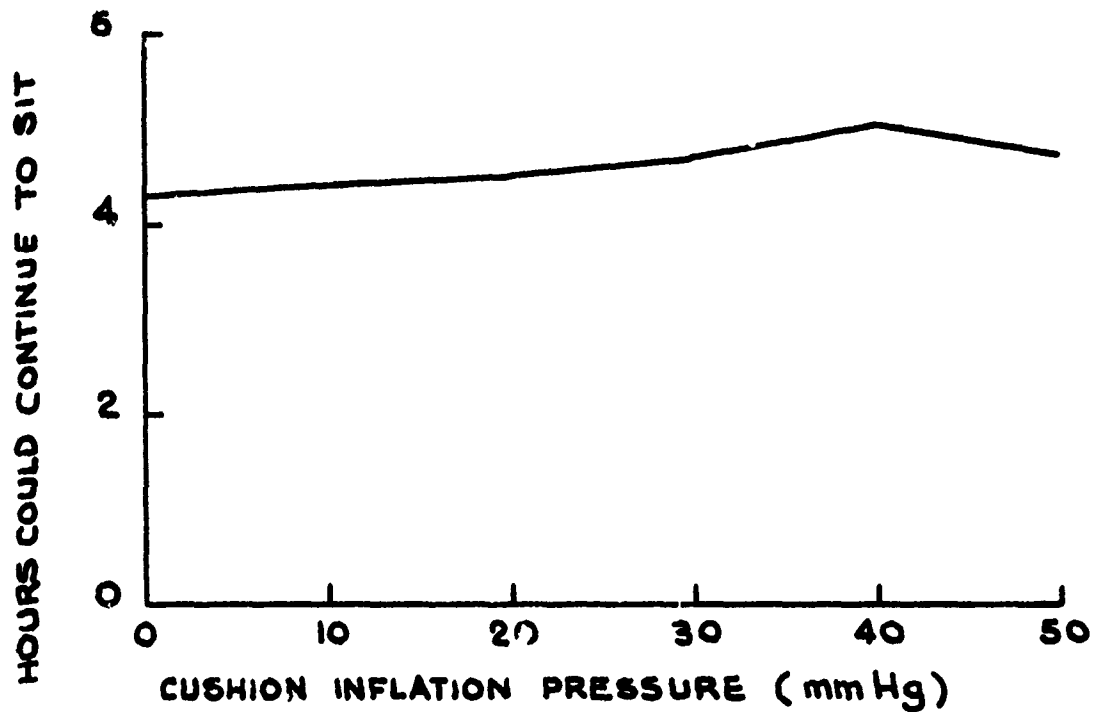

FIGURE 52
NUMBER OF HOURS SUBJECTS ESTIMATED THEY COULD
CONTINUE TO SIT AS A FUNCTION OF CUSHION INFLATION
PRESSURE FOR AN INFLATABLE SEAT CUSHION
AFTER SITTING FOR TWO HOURS

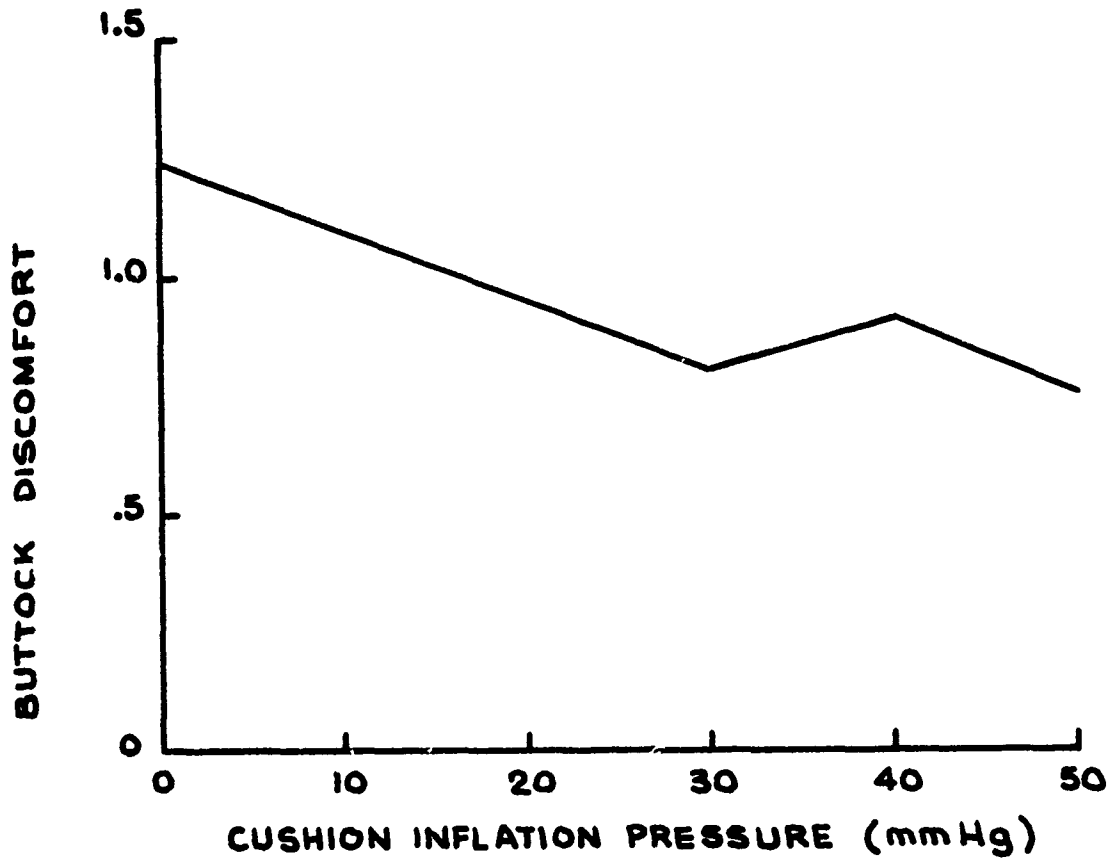

FIGURE 53
AVERAGE BUTTOCK DISCOMFORT FOR FOUR INFLATION
PRESSURES FOR AN INFLATABLE SEAT CUSHION

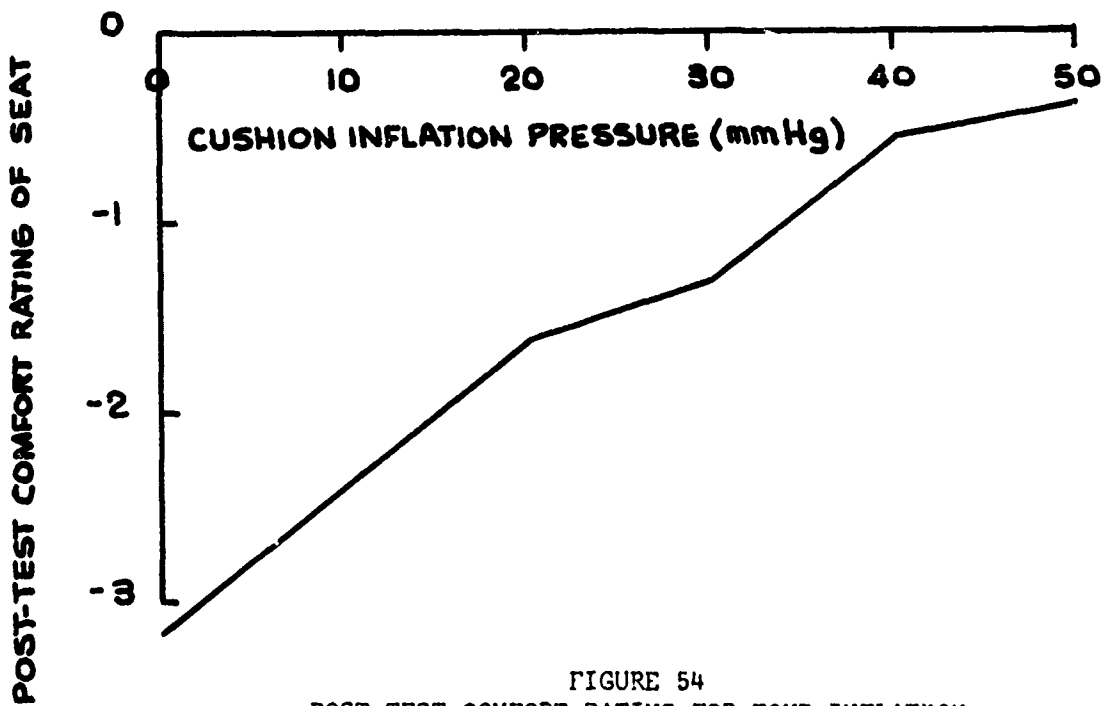

FIGURE 54
POST-TEST COMFORT RATING FOR FOUR INFLATION
PRESSURES FOR AN INFLATABLE SEAT CUSHION

TABLE VII

A COMPARISON OF SUBJECT PANELS FOR THE INFLATABLE
 AND PASSIVE CUSHIONS FOR THE ZERO-THICKNESS CUSHION

	Inflated Cushion Panel		Passive Cushion Panel		Difference in Means	t Ratio	Signifi- cance
	Mean Rating	Standard Error	Mean Rating	Standard Error			
Degree of Comfort	-1.04	0.12	-1.09	0.17	0.05	0.240	0.90
Buttock Discomfort	1.24	0.11	1.63	0.13	0.39	2.290	0.05
Final Rating	-3.14	0.54	-3.07	0.89	0.07	0.067	1.00

TABLE VIII

FREQUENCY OF COMPLAINTS DURING
 HOURLY EVALUATIONS OF SEAT CUSHIONS

Complaint:	Inflation Pressure - mm Hg				
	0	20	30	40	50
Too Firm	53	41	34	33	29
Too Soft	5	9	4	0	0
Too Wide	0	0	0	0	0
Too Narrow	2	5	4	3	6
Too Long	0	0	1	0	0
Too Short	4	5	4	3	5
Excessive Pressure On:					
Buttocks	45	40	39	33	27
Base of Spine	18	11	4	9	7
Thighs	8	4	2	8	5

TABLE IX

THE STATISTICAL SIGNIFICANCE OF THE DIFFERENCE IN
OVERALL COMFORT RATING FOR FOUR INFLATION PRESSURES
FOR AN INFLATABLE CUSHION

Differences Between	t	Significance Level
0-20 mm Hg	3.2211	0.01
0-30 mm Hg	3.802	0.001
0-40 mm Hg	4.392	0.001
0-50 mm Hg	5.779	0.001

TABLE X

THE STATISTICAL SIGNIFICANCE OF THE DIFFERENCE IN
NUMBER OF HOURS SUBJECTS ESTIMATED THEY COULD CONTINUE
TO SIT FOR FOUR INFLATION PRESSURES FOR AN INFLATABLE CUSHION

Differences Between	t	Significance Level
0-20 mm Hg	0.399	0.70
0-30 mm Hg	0.815	0.40
0-40 mm Hg	1.674	0.10
0-50 mm Hg	0.959	0.40

TABLE XI

THE STATISTICAL SIGNIFICANCE OF THE DIFFERENCE IN
 BUTTOCK DISCOMFORT FOR FOUR INFLATION
 PRESSURES FOR AN INFLATABLE CUSHION

Difference Between	t	Significance Level
0-20 mm Hg	1.779	0.10
0-30 mm Hg	2.960	0.01
0-40 mm Hg	1.938	0.10
0-50 mm Hg	2.121	0.05

TABLE XII

THE STATISTICAL SIGNIFICANCE OF THE DIFFERENCE IN
 POST-TEST FINAL RATING FOR FOUR INFLATION
 PRESSURES FOR AN INFLATABLE CUSHION

Difference Between	t	Significance Level
0-20 mm Hg	1.918	0.10
0-30 mm Hg	2.022	0.10
0-40 mm Hg	2.236	0.05
0-50 mm Hg	2.557	0.02

TABLE XIII

A COMPARISON OF INFLATABLE CUSHION RATINGS
AT 50 mm Hg INFLATION PRESSURE TO A
2-INCH CUSHION OF 1.6 LB/FT³ POLYURETHANE

	<u>Inflated Cushion</u>		<u>Passive Cushion</u>		Difference Between Means	t Ratio	Significance Level
	Mean Rating	Standard Error	Mean Rating	Standard Error			
Degree of Comfort	0.21	0.18	0.20	0.21	0.01	0.036	1.00
Buttock Discomfort	0.76	0.11	1.14	0.12	0.38	2.334	0.05
Final Rating	-0.39	0.93	0.45	0.97	0.85	0.633	0.60

TABLE XIV

A COMPARISON OF THE INFLATABLE
CUSHION TO THE F104 AND F101 CUSHIONS

Comparison	Rating Scale	t Ratio	Significance Level
F104 to Inflatable	Overall Comfort	3.26	1%
F101 to Inflatable	Overall Comfort	2.50	5%
F104 to Inflatable	Buttock Discomfort	0.12	N.S.
F101 to Inflatable	Buttock Discomfort	0.12	N.S.
F104 to Inflatable	Post-Test	2.72	5%
F101 to Inflatable	Post-Test	2.07	5%

STATIC LOAD-DEFLECTION TESTS OF THE INFLATABLE CUSHION

The fabrication technique adopted for the design of the inflatable cushion involved the bonding of a thin piece of Ensolite to an aluminum plate as described for the passive cushion. Then the inflatable rubber membrane was wrapped over the foam and the metal plate was glued in place. Load deflection curves for the cushion in the deflated condition were equivalent to those of the passive cushion.

A series of tests were also run with the inflatable cushion in the inflated condition. The test procedure involved use of the double ellipsoid indenter foot placed on the inflatable cushion with the hydraulic test rig. The cushion was inflated to a fixed inflation pressure. The load in pounds on the double ellipsoid indenter and the inflation pressure of the cushion were adjusted jointly, keeping the inflation pressure constant and gradually increasing the load in pounds. The result of this test procedure is shown in Figure 55, which gives the load-deflection curves for inflation pressures of 25, 30, 35, 40, 45, and 50 mm Hg over a load range from 110 to 150 lbs. The results show the relative stiffness of the cushion for various inflation pressures, the cushion being much softer when inflated than when uninflated, as would be expected.

INFLATION/DEFLATION UNIT DEVELOPMENT AND TEST

An inflation/deflation control unit was designed to control the seat cushion. Two modes of operation of the inflation/deflation unit are possible. In the automatic mode, the unit sequentially inflates and deflates the cushion on a time schedule established by controls on the front panel of the unit. The period of time the cushion is inflated and the period of time it is deflated can be controlled separately so that any combination of cycle characteristics is possible. Timing intervals can be set from 20 seconds to 180 seconds with continuous variation over that range. During automatic inflation cycle operations, the pressure to which the cushion is inflated is controlled by a pressure regulator knob on the front panel of the unit.

A continuous mode of operation is also available, resulting in constant inflation of the cushion at the pressure level set with the regulator setting on the front panel. Cycling does not occur with this mode, although the seat occupant can manually cycle the cushion up and down by adjusting the pressure regulator (inflatable cushion).

Figure 56 is an overall schematic of the unit. A solenoid valve is used to control the inflation and the deflation in the automatic mode of operation. The solenoid valve is held open during the continuous mode of operation. A flow control valve is incorporated in the unit so that the rate of inflation and deflation can be adjusted. However, the flow controller is not accessible from the front panel, and must be preset after taking off the unit's outer cover.

The automatic mode of operation is controlled by a flip flop circuit utilizing 28 volt DC power. The schematic for the flip flop circuit is shown in Figure 57. As noted in the figure, the circuit can be adjusted to the solenoid valve load through the selection of Resistor R_L .

Naturally, the rate of inflation and deflation of the cushion is limited not only by the pneumatic supply, but by the orifice into the inflatable bladder. The time to inflate or deflate to a pressure of 50 millimeters of mercury with a 150 pound load on the seat cushion was found to be 325 seconds in tests. This inflation/deflation interval is satisfactory for normal flight operation of the cushion when the comfort characteristics are of primary importance. However, the principle of operation of the inflatable cushion requires that it deflate rapidly and completely prior to ejection. The prototype cushion, as designed and fabricated, deflated too slowly. A series of tests were conducted with a cushion which had multiple exhaust orifices to determine the deflation times for various total orifice sizes. Ten 1/8" i.d. tubes were used in the experimental cushion, and the number of open orifices would be controlled so that any number from 1 to 10 could be used to deflate the cushion. Figure 58 shows the pressure versus time curve for deflations with one through ten 1/8" i.d. orifices. Figure 59 shows the rate of tuberosity pressure increase for five deflation orifice conditions up to five parts and .030 square inches. Both sets of test data, when interpreted, indicate that a total orifice area of approximately .018 to .030 square inches is required to provide deflation in one second or less.

The deflation time tests demonstrate that it is feasible to deflate the cushion rapidly enough for use in an ejection seat providing there is an interval between ejection seat handle actuation and initial motion up the rails of 500 milliseconds or more.

OPTIMIZATION OF THE INFLATABLE SEAT CUSHION

Since the inflatable cushion was designed with the same basic materials as the passive cushion, the injury probability curve of Figure 40 in the previous section is applicable. However, the comfort probability of the inflatable cushion is independent of the polyurethane foam thickness as shown in Figure 60, which also presents the injury probability curve and the optimization curve. Because the comfort probability curve does not vary with foam thickness, the optimum cushion is one with no polyurethane foam at all. This is a clearcut optimization case, and the optimum point is, in fact, totally independent of the cushion uninflated thickness.

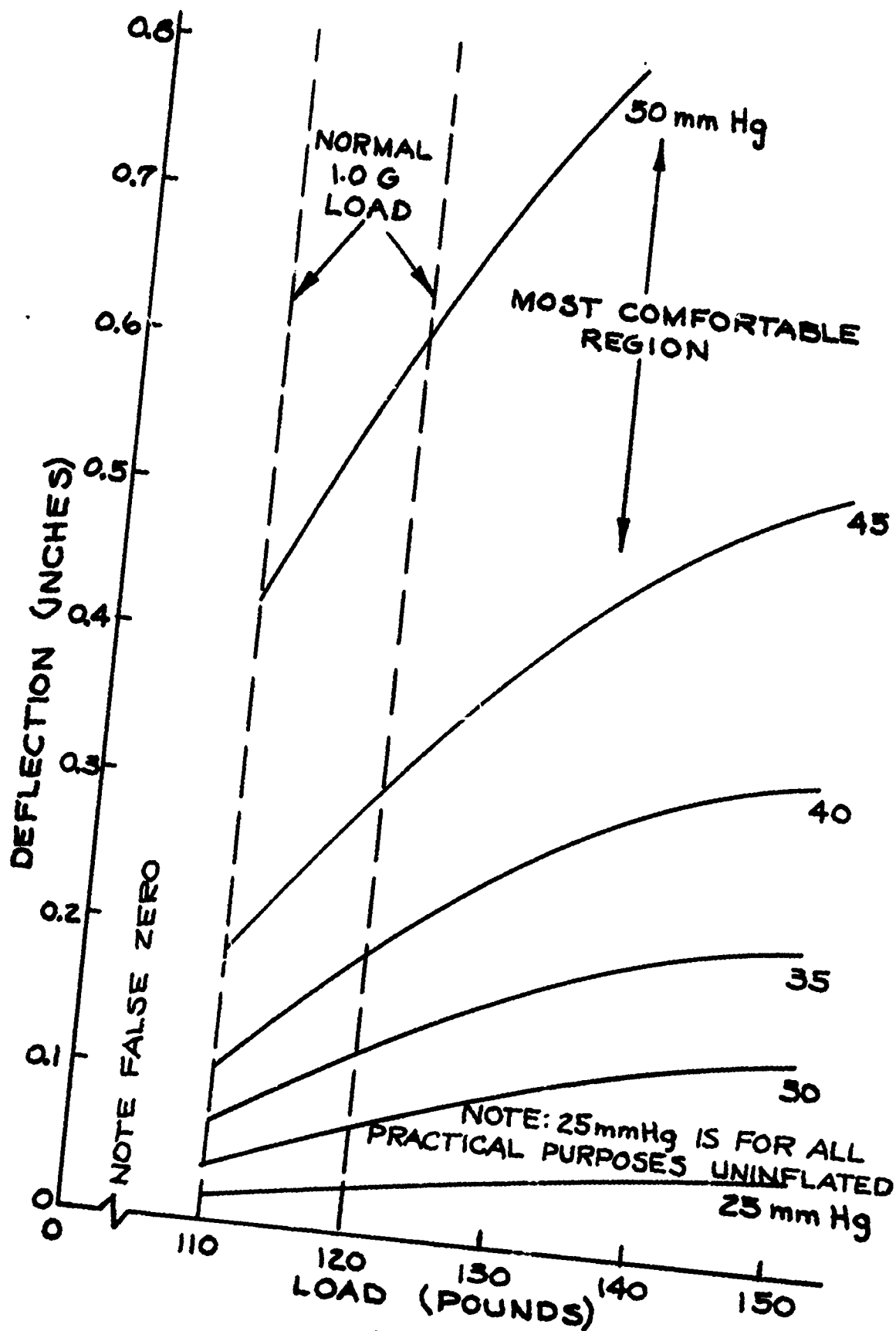

FIGURE 55
RESULTS OF TESTS CONDUCTED WITH DOUBLE
ELLIPSOID INDENTOR FOOT (MODIFIED F4C CUSHION)

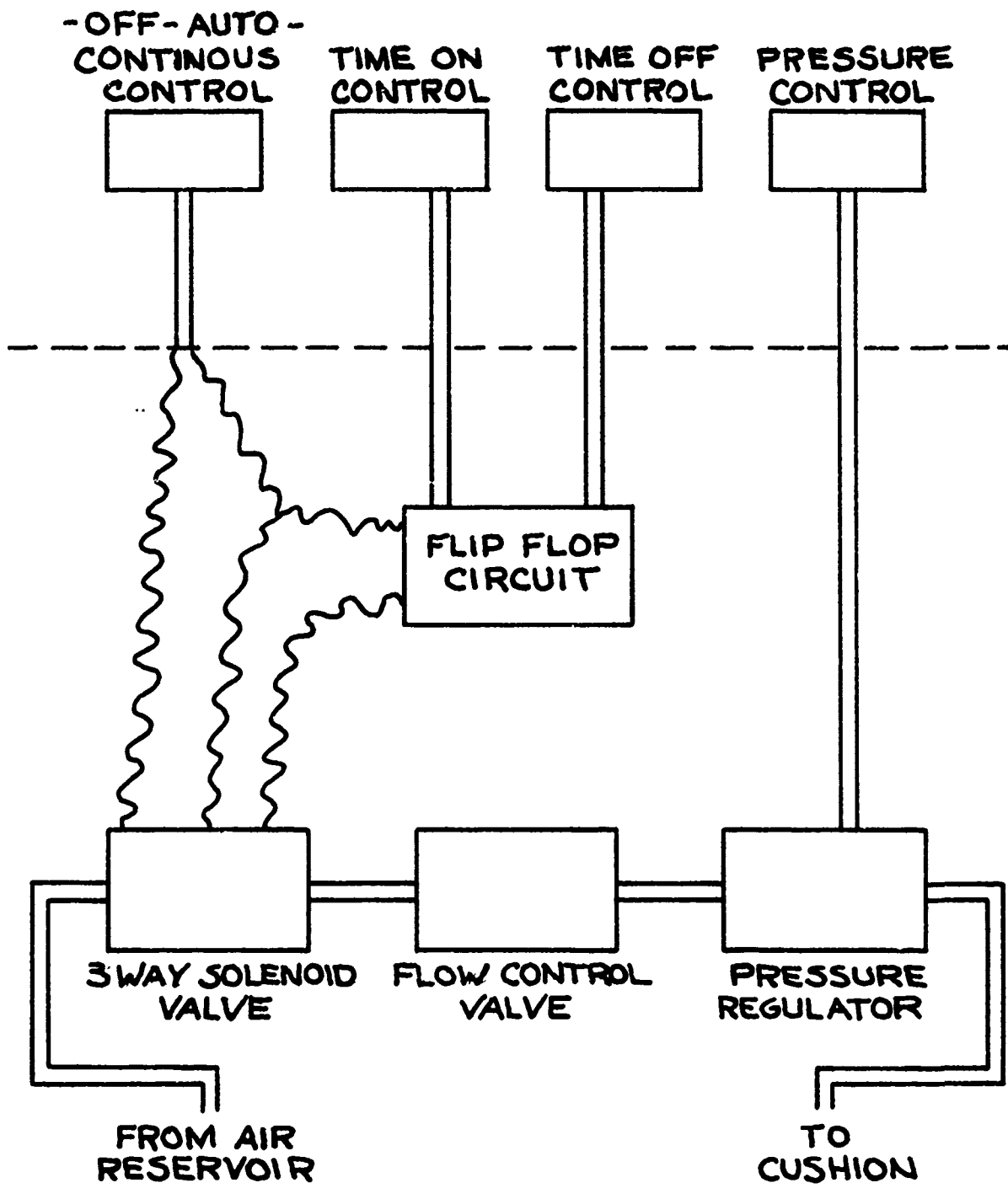

FIGURE 56
PNEUMATIC AND ELECTRONIC
SCHEMATIC OF INFLATION CONTROL UNIT

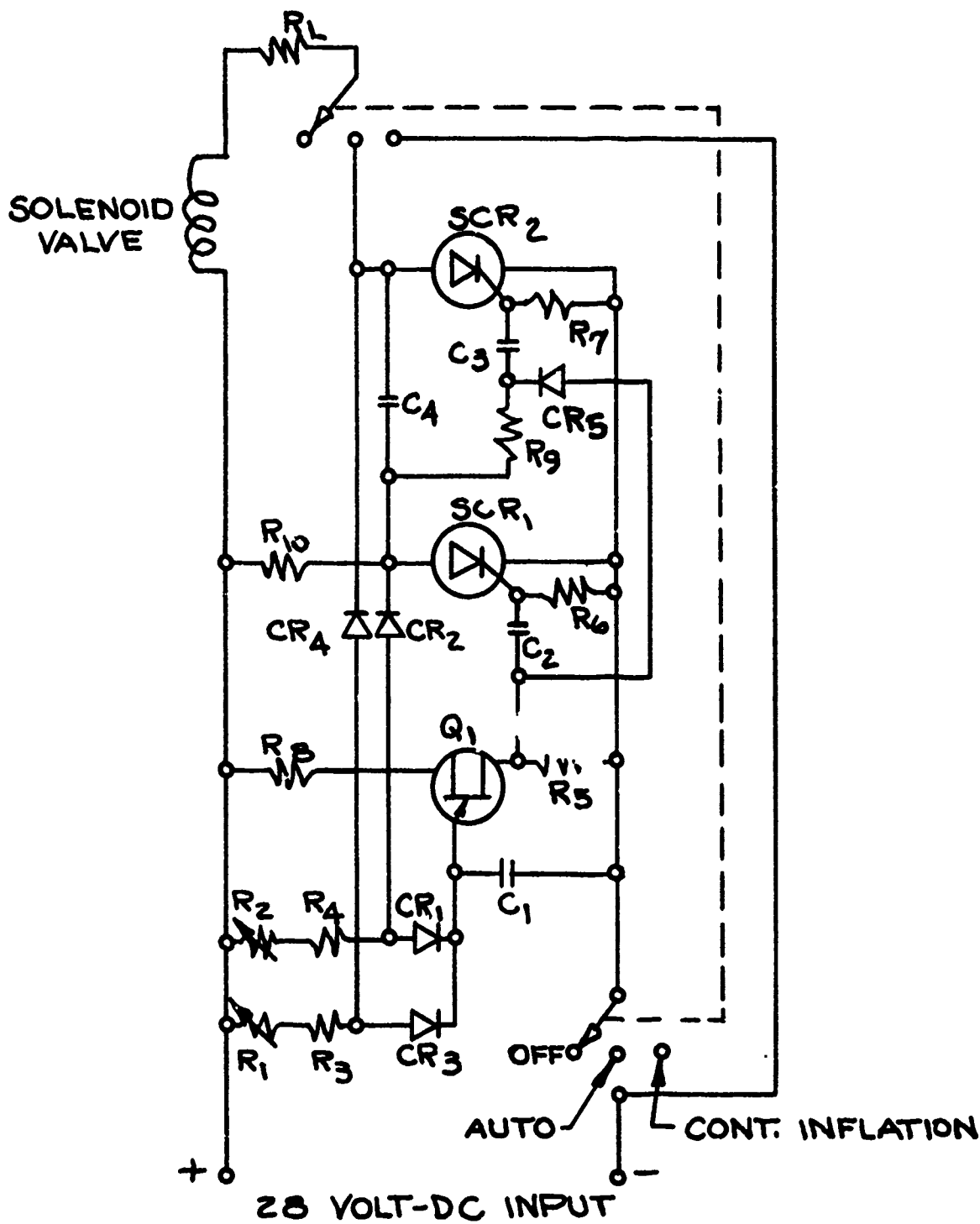

FIGURE 57
SCHEMATIC, ACTIVE CUSHION PNEUMATIC CONTROL

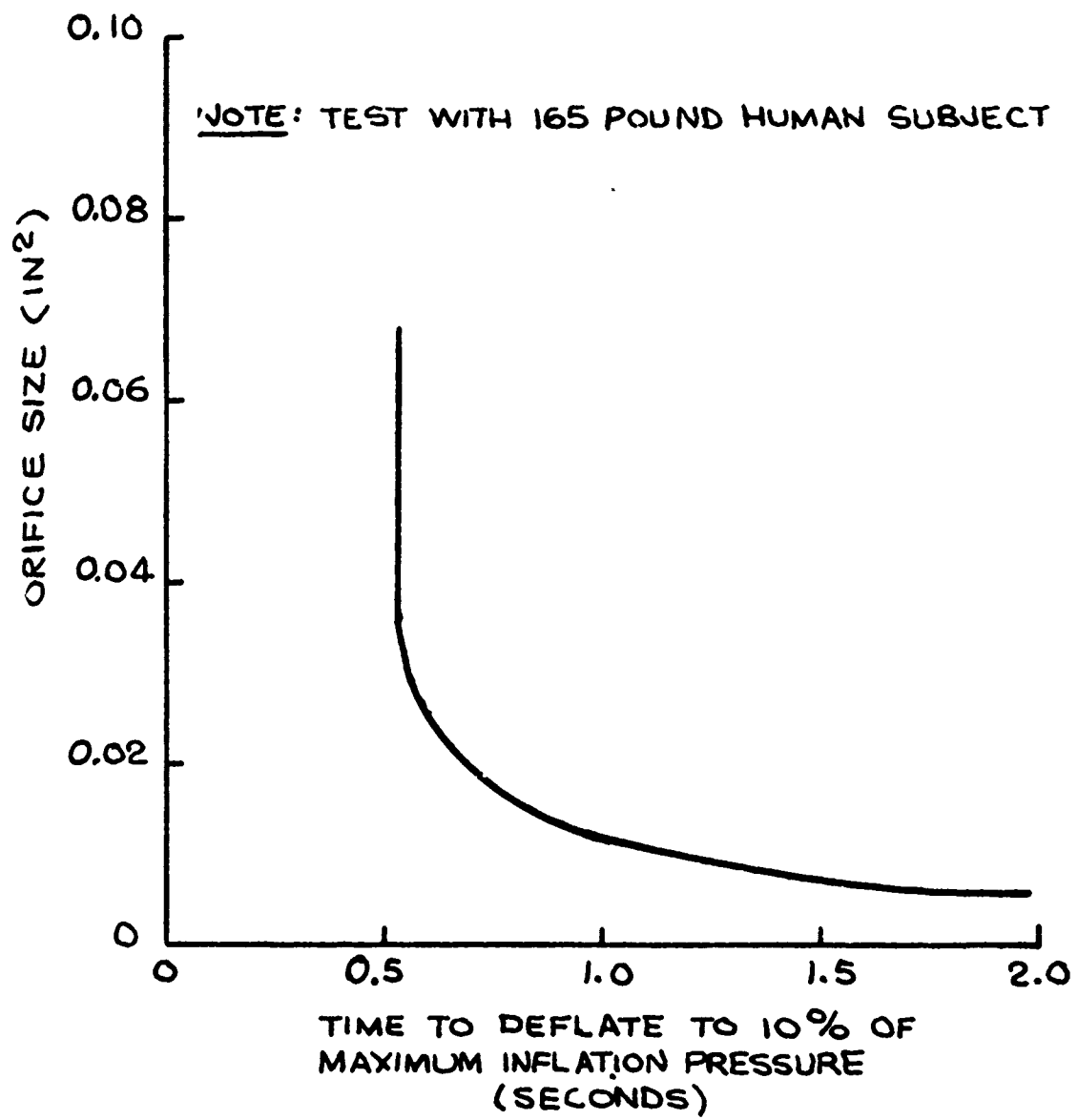

FIGURE 58
DEFLATION TIME FOR VARIOUS ORIFICE
AREAS FOR AN INFLATABLE CUSHION

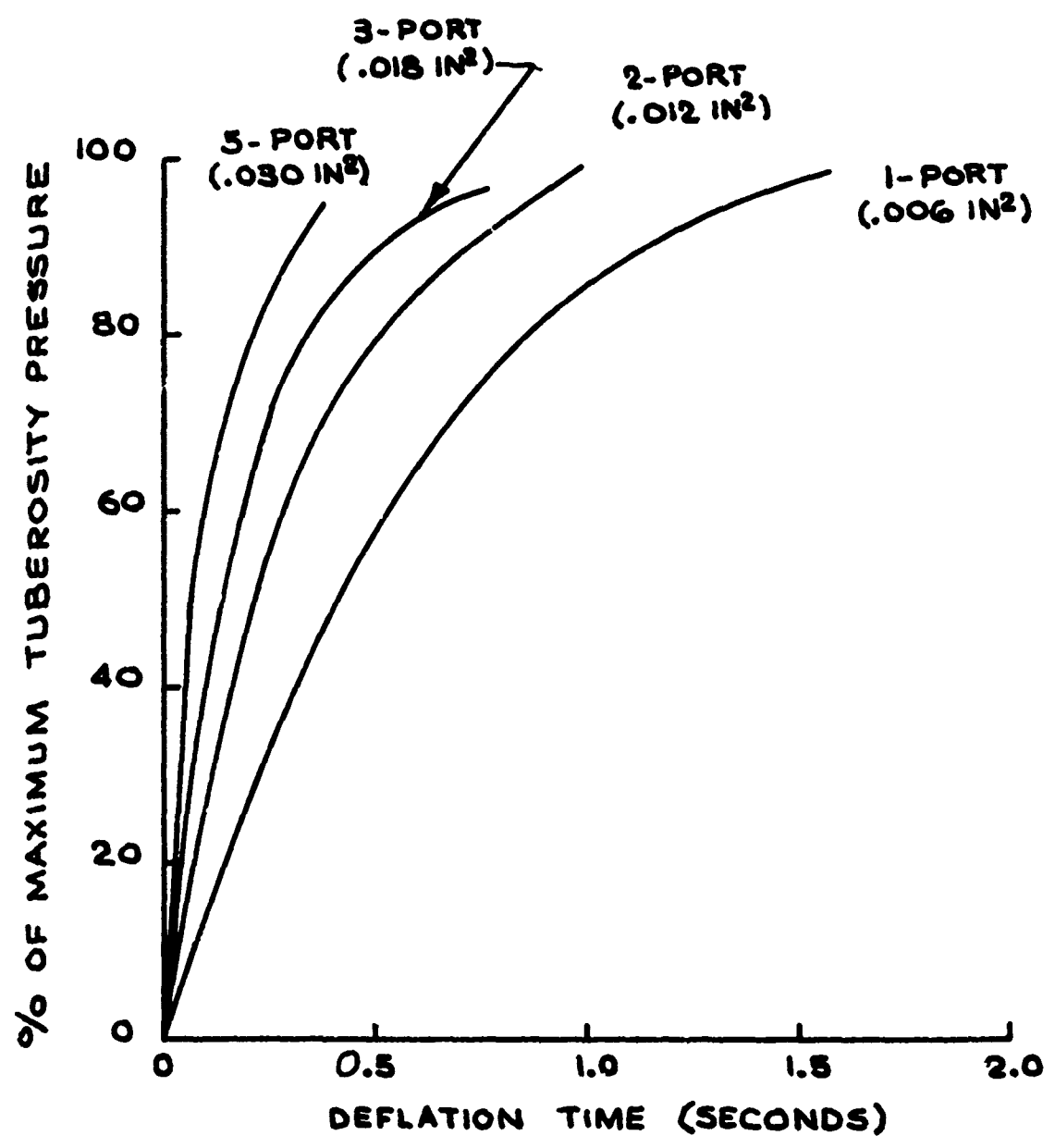

FIGURE 59
RATE OF TUBEROSITY PRESSURE
INCREASE FOR AN INFLATABLE CUSHION

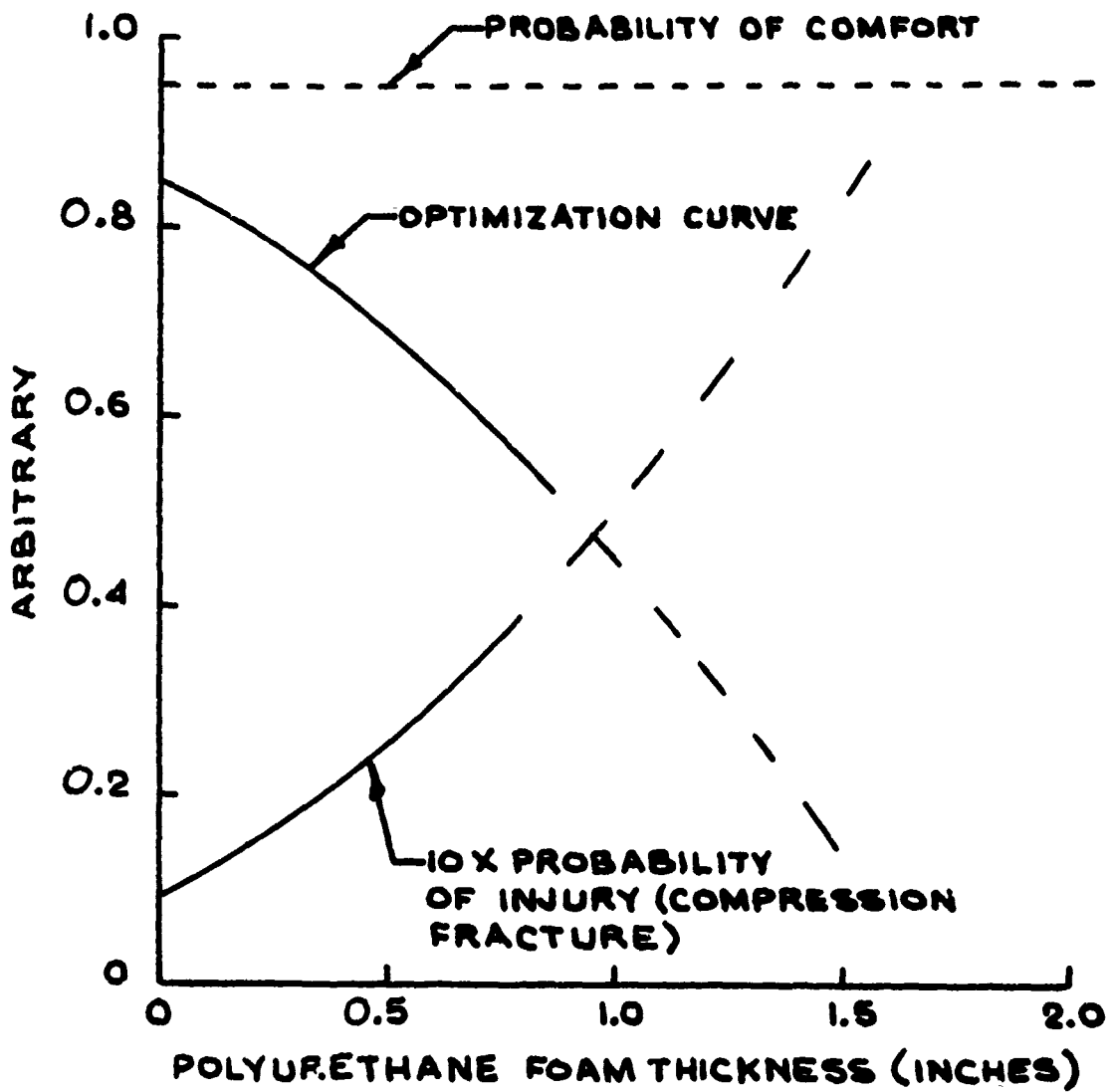

FIGURE 60
OPTIMIZATION CURVE OF A 1/4-INCH
ENSOLITE INFLATABLE CUSHION WITH POLYURETHANE FOAM

SECTION VI

CONCLUSIONS AND RECOMMENDATIONS

The data obtained in this research, the analytical methods used in evaluating the data, and the test methods used in generating the data lead to various conclusions on cushion optimization and on future research and development needs.

CONCLUSIONS AND RECOMMENDATIONS OF OPTIMIZATION METHOD

A method for optimizing seat cushion design was developed, and the following conclusions and recommendations grew out of the development.

- (a) An optimization curve can be generated by converting dynamic response into probability of injury, and by converting comfort test data into probability of improved comfort. Generally, the probability of comfort and the probability of injury both increase as the cushion thickness increases. Thus, the maximum point on a curve in which probability of comfort is subtracted from probability of injury, will be the optimum cushion thickness.
- (b) In cases where no true optimum occurs or where the comfort-injury optimum results in too high an injury risk, the cushion designer should try a new design approach or limit the cushion thickness to a maximum dictated by injury risk.
- (c) The physical significance of the optimization procedure needs to be studied further, both in comfort and dynamic response tests, to verify the underlying concepts and measurements.

CONCLUSIONS AND RECOMMENDATIONS ON MECHANICAL TESTING

Mechanical tests are required to obtain stiffness and damping estimates which can be used in a dynamic analysis of a cushion. Test procedure conclusions and recommendations include:

- (a) The load-deflection curve obtained in a test is a function, in part, of the indenter foot used, particularly for foam densities in excess of 3.0 lbs/ft³.
- (b) A series of load-deflection curves should be obtained on a cushion using human subjects of 5th, 50th, and 95th percentile weight. The buttock indentation under the ischial tuberosities should be measured with the subject's full weight on the cushion, with the subject holding 25% - 50% of his weight off the cushion, and then with weights of 50 lbs. and 100 lbs. added to the subject's weight.

- (c) A series of load deflection curves should be obtained on a cushion with loads of 50, 100, 150, 200, 250, and 300 lbs. using a 50 in² flat plate indenter, a single ellipsoid indenter, and a double ellipsoid indenter. These curves should be compared to the curves obtained with human subjects, and the indenter producing the nearest equivalent curve to the human buttocks should be used to obtain load-deflection data up to 4000 lb. load.
- (d) Dynamic rebound tests using a mass of 100-150 lbs. should be employed to obtain a rough estimate of the damping coefficient of the cushion. The indenter used for high load tests should be used in the dynamic tests.

CONCLUSIONS AND RECOMMENDATIONS ON COMFORT TESTING

The use of comfort tests in evaluating seat cushions was found to be feasible, and these recommendations are offered for future cushion development programs:

- (a) Comfort tests using the subjective responses of a panel of 12 to 15 subjects have been shown to be quite sensitive to cushion thickness and density parameters. Such comfort tests should be used to generate a comfort versus thickness curve for any new developmental cushion.
- (b) If possible, tuberosity pressure measurements should be made during comfort tests with 9 to 10 square inch transducing surface under each tuberosity.

CONCLUSIONS AND RECOMMENDATIONS ON DYNAMIC ANALYSIS

Although the dynamics of seat cushions have been investigated analytically in the past, the present program showed that certain parameters are of particular importance in an optimization procedure:

- (a) The dynamic analysis of a cushion should provide a plot of cushion thickness versus the dynamic response ratio, i.e., the attenuation or amplification of the input acceleration as shown in Figure 39.
- (b) For optimization purposes, the slope of the dynamic response ratio line is not critical, but the point where the curve begins to show amplification is critical. Therefore, the dynamic analysis should be checked for factors which affect this point.
- (c) The development of a more adequate dynamic model than the one-mass single degree-of-freedom model used in this study is needed, principally to add a second mass representing the pelvis-thigh mass in a human being.

- (d) The development of dynamic test methods is needed in order to verify analytical results and to provide empirical sources of data on actual developmental cushions.

CONCLUSIONS AND RECOMMENDATIONS ON PASSIVE AND INFLATABLE CUSHION OPTIMIZATION

Specific conclusions on the two types of cushions developed in the present program included:

- (a) Injury probability increases and comfort rating also increases as cushion thickness increases. Therefore, most passive cushions have a true optimum thickness which gives the most comfort for the least risk.
- (b) The best seat cushion material is one which provides the maximum seat comfort at the lowest possible risk of all possible seat cushion designs.
- (c) Because an inflatable cushion can be deflated prior to ejection or crash, it has no true optimum as is the case for the passive cushion. The design problem for an inflatable cushion, therefore, is how to make it as comfortable as possible while inflated, how to deflate it rapidly prior to ejection, and how to provide minimal elastic resilience after deflation.

APPENDIX A

Analog Results of Acceleration Inputs
To a Simple Man Model in Series With
19 Different Cushion Models

D. A. Shaffer

Payne Division
Wyle Laboratories
Rockville, Maryland

INTRODUCTION

The purpose of this paper is to study the dynamic response of an ejection seat cushion upon the seat's occupant. The studies were carried out with the aid of an analog computer using a linear spinal man model.

GENERAL THEORY

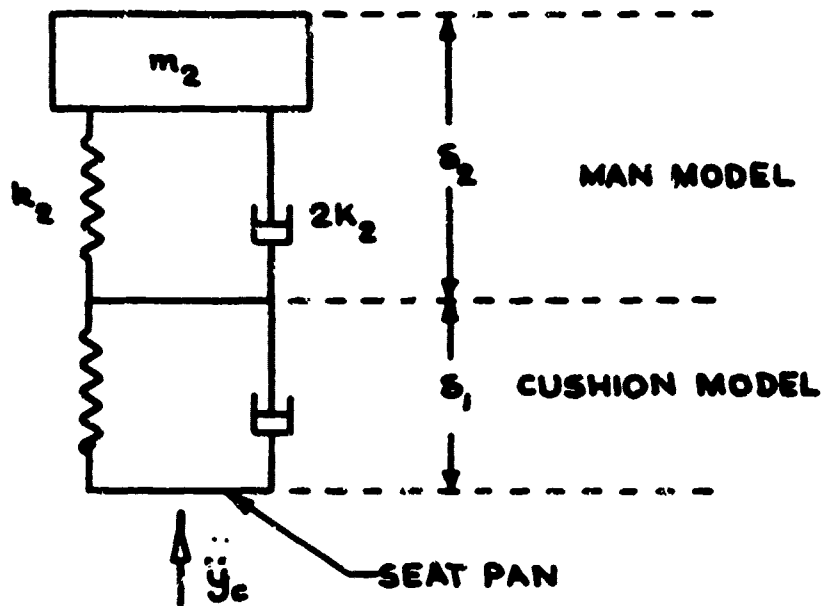

FIGURE 61
THE DYNAMIC MAN MODEL PLUS SEAT CUSHION

Let $c = \frac{2K_2}{m_2}$, $\omega^2 = \frac{k_2}{m_2}$, and $f(\delta_1) = \frac{\text{cushion force.}}{m_2}$

Then, prior to bottoming, the equations of motion are

$$\ddot{\delta}_2 + c \dot{\delta}_2 + \omega^2 \delta_2 = \ddot{y}_c - \ddot{\delta}_1 \quad (1)$$

and

$$c \dot{\delta}_2 + \omega^2 \delta_2 = f(\delta_1) \quad (2)$$

Proceeding page blank

If

$$\delta_T = \delta_1 + \delta_2$$

then substituting into (1) yields

$$\ddot{\delta}_T = \ddot{y}_c - c\dot{\delta}_2 - \omega^2\delta_2 \quad (3)$$

Equations (2) and (3) were used to construct the analog circuitry in Figure 62.

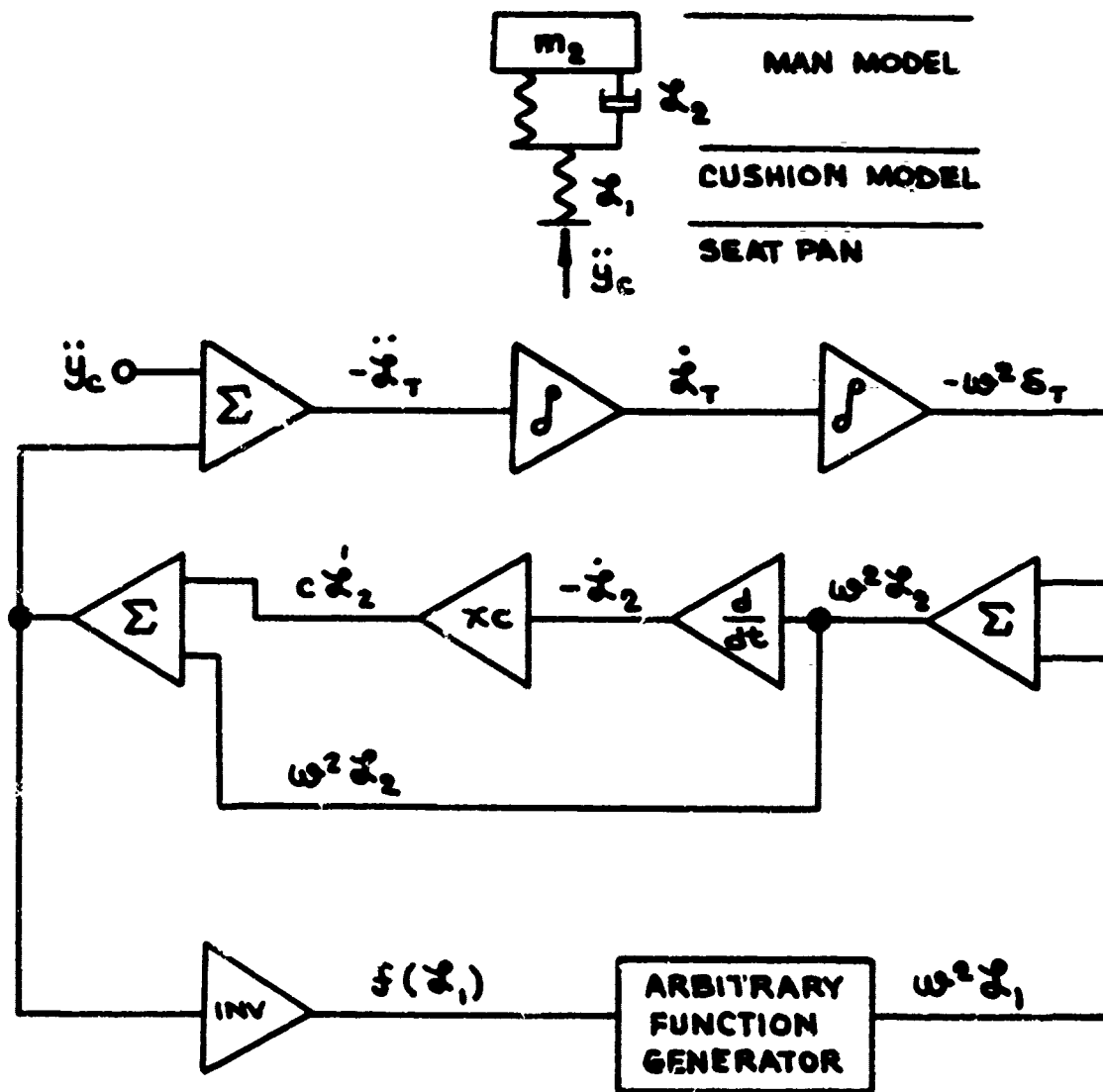

FIGURE 62
ANALOG FOR ANALYZING ACCELERATION
INPUTS INTO A SIMPLE MAN AND CUSHION MODELS

The acceleration input to the seat pan is shown below, Figure 63, in real time.

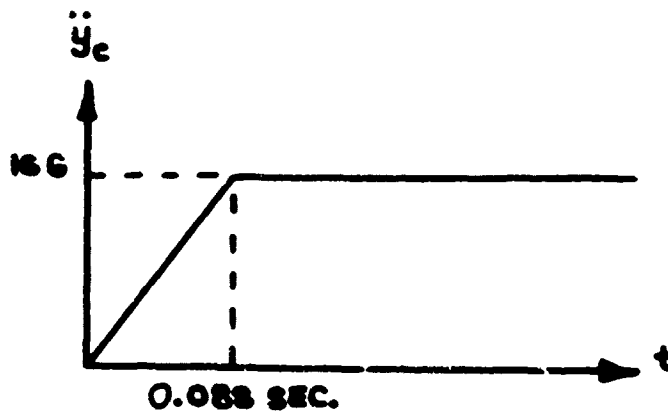

FIGURE 63
 OPERATIONAL ACCELERATION INPUT

TEST RESULTS AND CONCLUSIONS

The seat cushions were evaluated with a 60 lb. initial loading, 1-g, which represented the upper torso mass. With this pre-loading the cushion and man model were subjected to the operational acceleration input. The response of the man model was measured (DRI) and compared against his response when the cushion model was removed (DRI_0). The results are shown in Table XV and are expressed in the form of DRI/DRI_0 . Also, Figures 64 through 68 show the load-deflection curves of the cushion tested as duplicated in the arbitrary function generator.

Of the 14 model cushions tested, it was found that three attenuated the reference response, two had no effect, and nine increased the reference DRI value.

The tests proved to be very interesting in that they showed that a cushion might have to be more or less tailored to a specific individual. For, if the seat occupant's weight varies, the value of DRI/DRI_0 could change. Also, the absolute thickness of the cushion is not critical. The guiding factor is the form of the load-deflection curve above the pre-loaded value. From an empirical point of view it appears that after the seat has been pre-loaded, the cushion should not deflect more than 0.1 inches under a 16 g input. When this condition is met, the DRI appears to be attenuated.

For a more realistic evaluation of the seat occupant's response to the acceleration input, one would have to modify the analog to include the effect of the lower pelvic mass as shown in Figure 69.

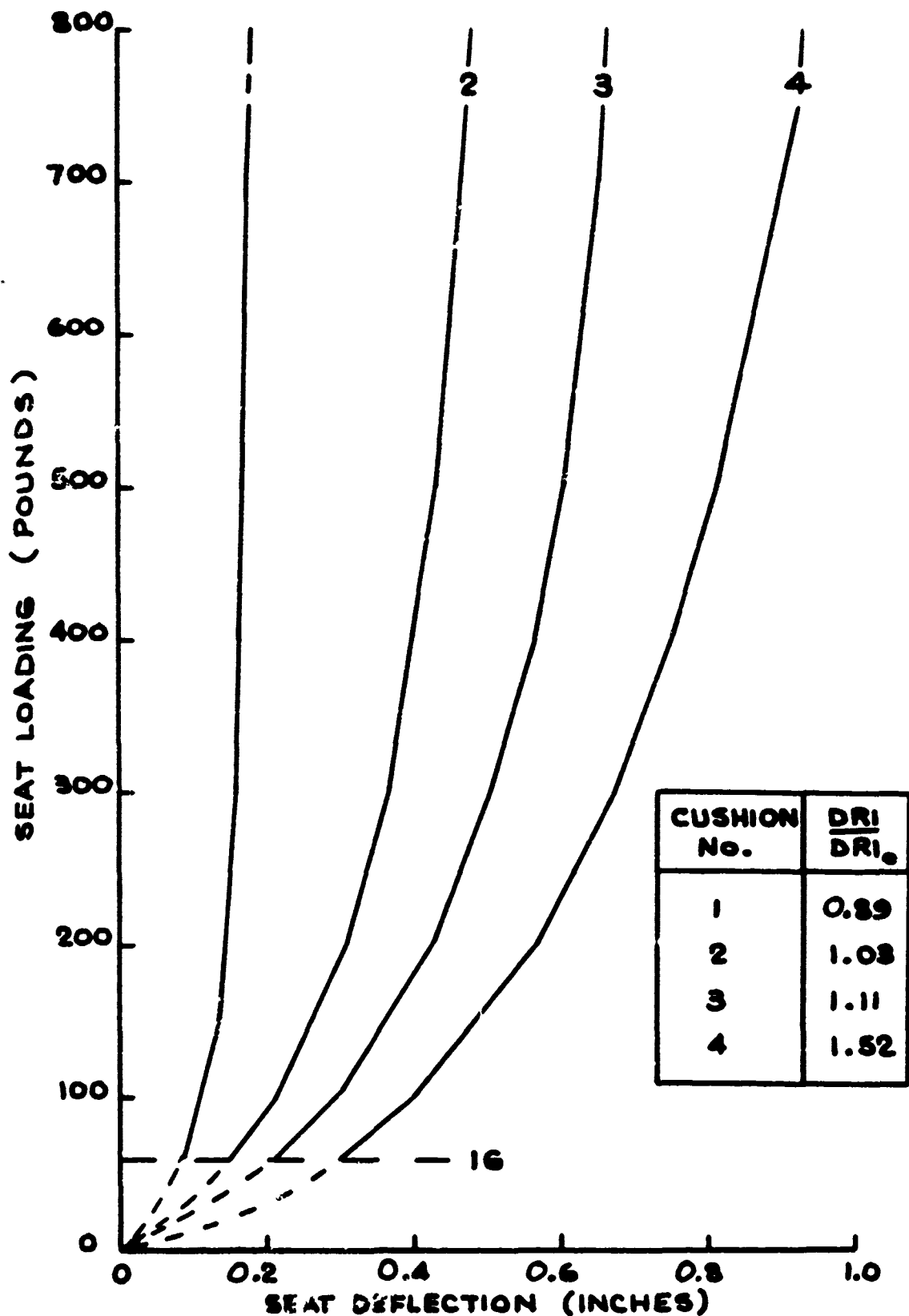

FIGURE 64
 LOAD-DEFLECTION CURVES FOR CUSHIONS 1, 2, 3, AND 4
 (CONSISTING OF 1/4, 1/2, 3/4, AND 1-INCH ENSOLITE)

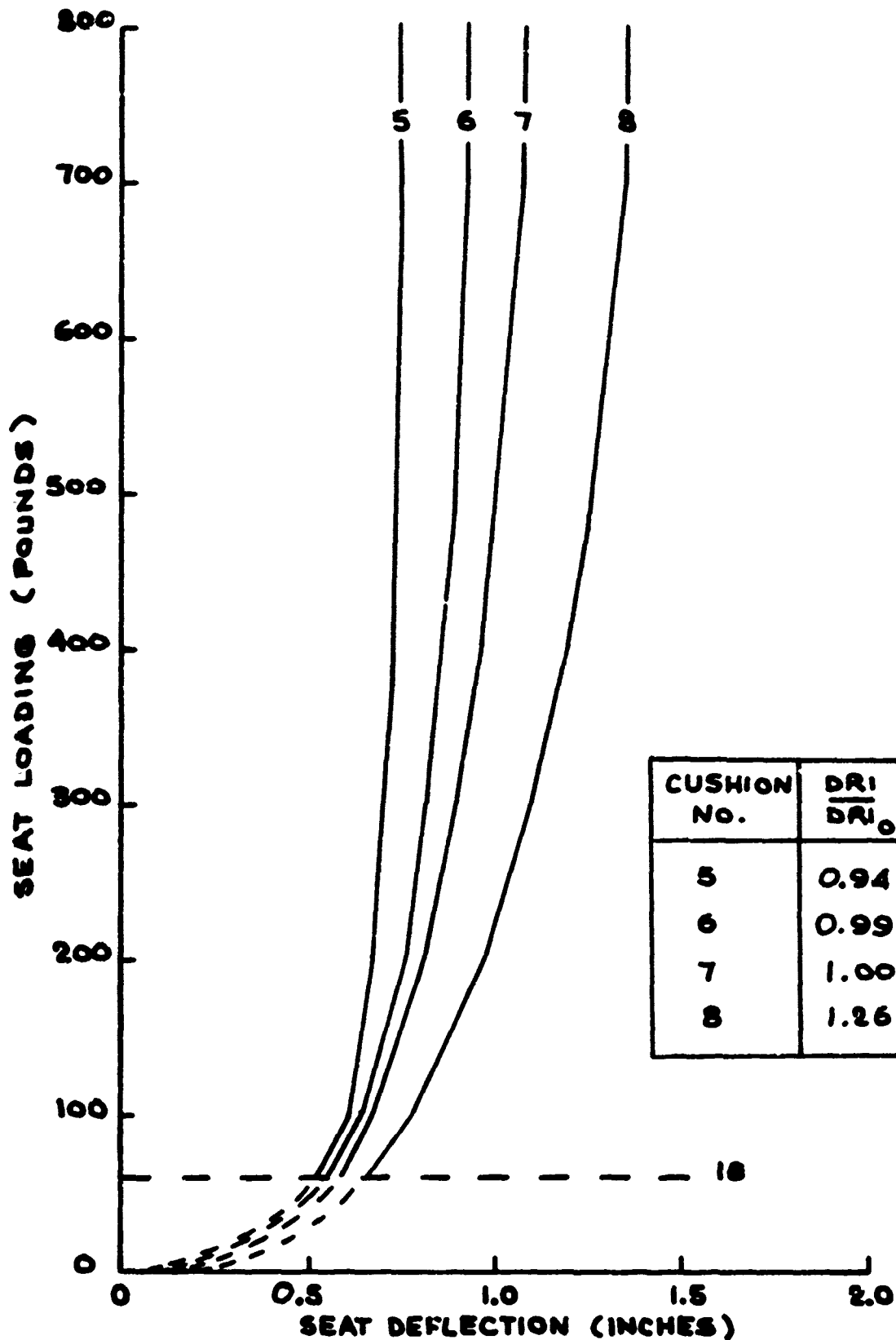

FIGURE 65
LOAD-DEFLECTION CURVES FOR CUSHIONS
5, 6, 7, AND 8 (CONSISTING OF 1/4, 1/2, 3/4, AND 1-INCH
ENSOLITE PLUS 1-INCH OF 1.6 LB/FT³ POLYURETHANE FOAM)

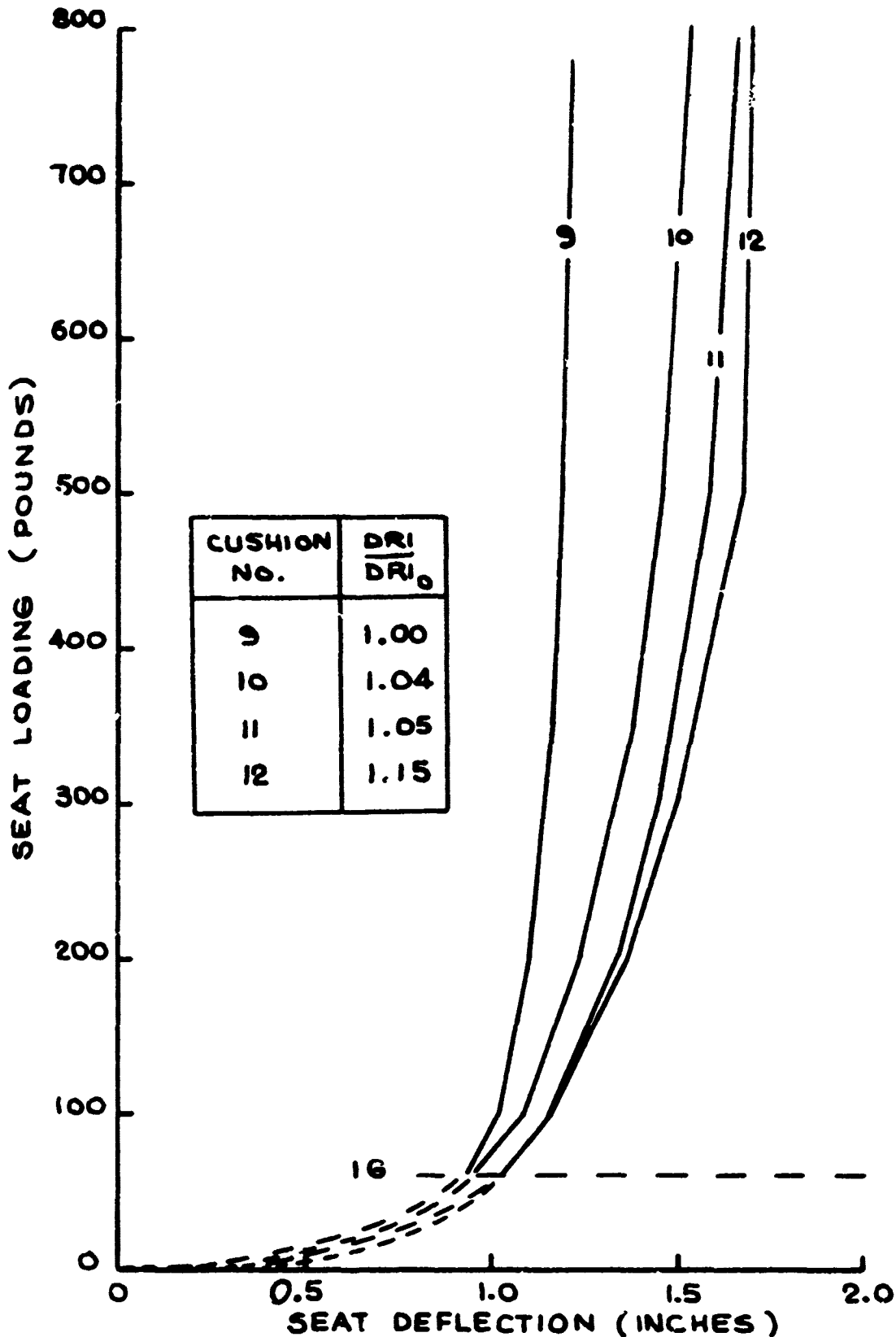

FIGURE 66
 LOAD-DEFLECTION CURVES FOR CUSHIONS
 9, 10, 11, AND 12 (CONSISTING OF 1/4, 1/2, 3/4, AND 1-INCH
 ENSOLITE PLUS 2-INCHES OF 1.6 LB/FT³ POLYURETHANE FOAM)

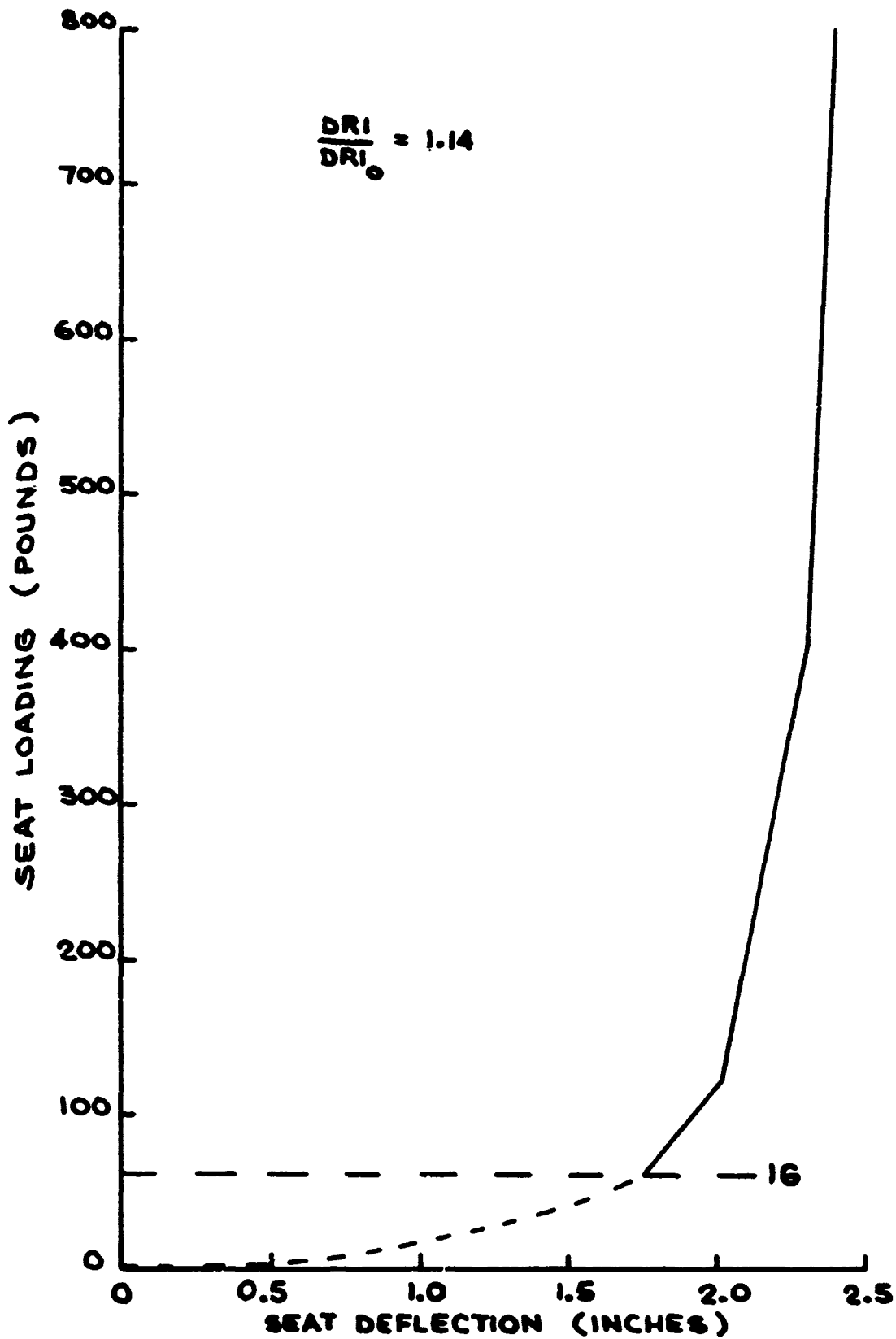

FIGURE 67
LOAD-DEFLECTION CURVE FOR CUSHION 13,
AIR FORCE OPERATIONAL F104 EJECTION SEAT CUSHION

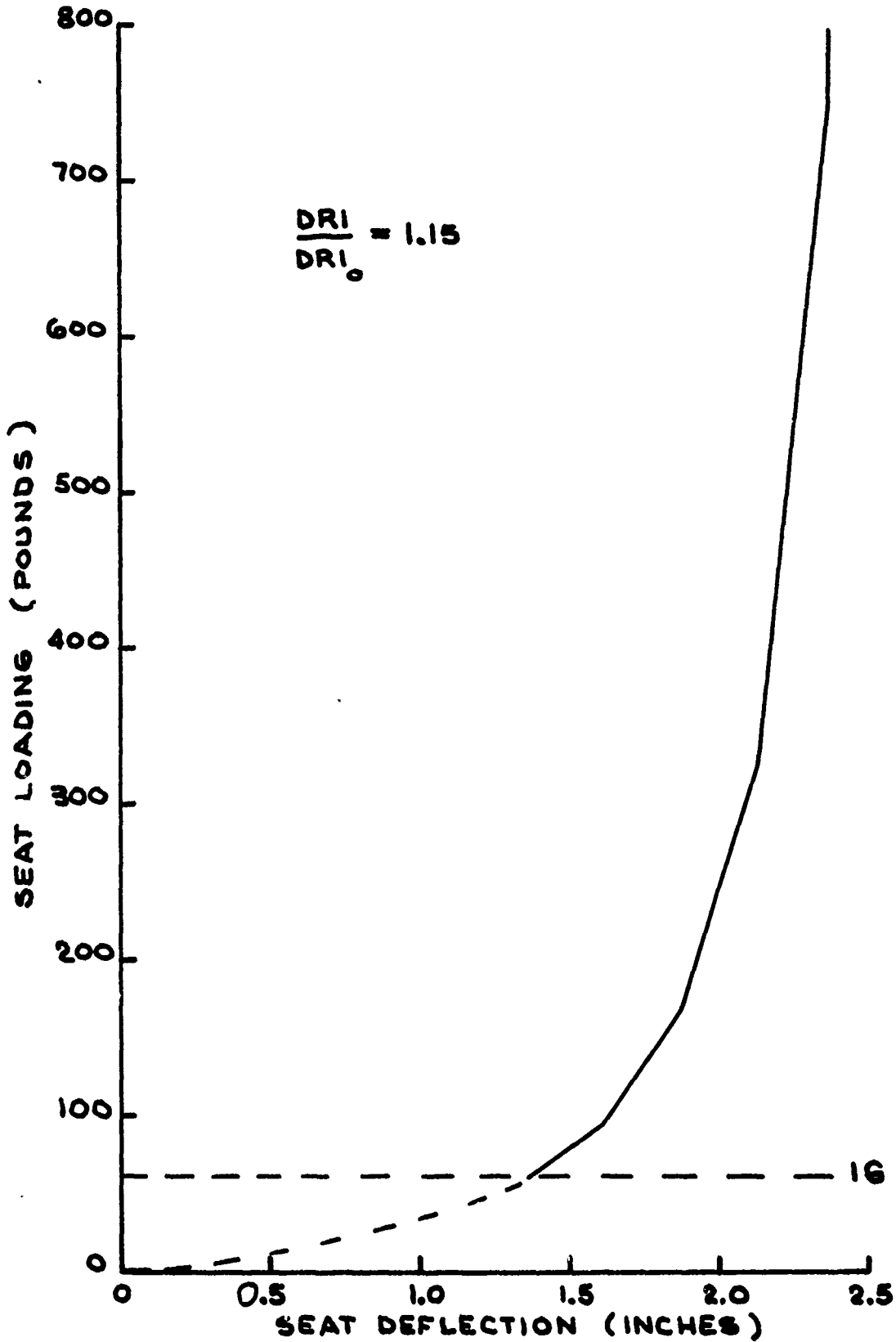

FIGURE 68
LOAD-DEFLECTION CURVE FOR CUSHION 14,
AIR FORCE OPERATIONAL F101 EJECTION SEAT CUSHION

TABLE XV
SCHEDULE OF RESULTS FOR CUSHION TESTS

Cushion	Total Thickness (Inches)	Bottoming Depth (%)	Deflection Under 1G (60 lbs) (Inches)	$\frac{DRI}{DRI_0}$
1	0.25	-	0.08	0.89
2	0.50	-	0.45	1.03
3	0.75	-	0.21	1.11
4	1.00	-	0.30	1.52
5	0.75	90-95	0.54	0.94
6	1.00	90-95	0.56	0.99
7	1.25	90-95	0.60	1.00
8	1.50	90-95	0.66	1.26
9	1.25	90-95	0.92	1.00
10	1.50	90-95	0.96	1.04
11	1.75	90-95	1.02	1.05
12	2.00	90-95	1.02	1.15
13	2.50	90-95	1.35	1.15
14	2.50	90-95	1.75	1.14

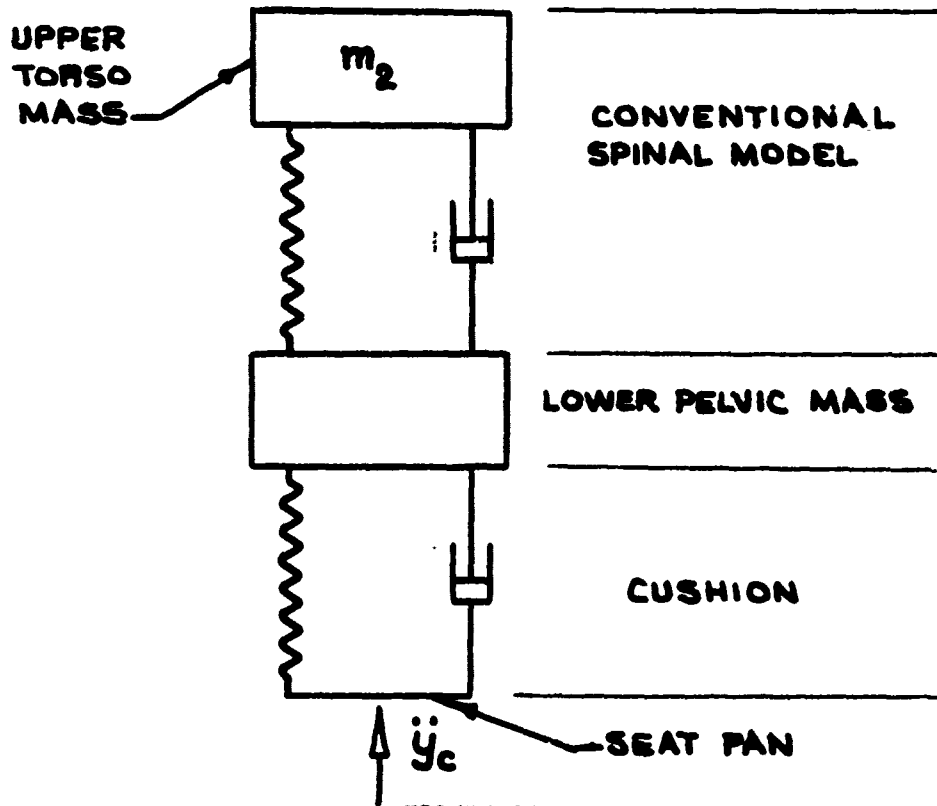

FIGURE 69
THE DYNAMIC MASS MODEL WITH THE LOWER PELVIC MASS INCLUDED PLUS SEAT CUSHION

APPENDIX B

TEST PROCEDURES

LOAD-DEFLECTION TESTS

Static tests were run in accordance with the test procedures outlined in MIL-S-27332A (USAF) dated 12 January 1966. Testing was performed with a hydraulic load application test device pictured in Figure 70. A hydraulic cylinder with a swivel end-fitting was used to apply the loads through a flat 50 sq. inch indenter foot and through ellipsoid and double ellipsoid indenter feet. The 50 sq. inch flat plate indenter was made in accordance with the requirements of MIL-S-27332A (USAF). The ellipsoidal feet were selected as the nearest regular geometrical shapes representing the human hips and buttocks. All three indenter feet are pictured in Figure 71.

The cushion sample was supported on a flat horizontal plate perforated with 1/4" holes on 3/4" centers as required by MIL-S-27332A (USAF). The seat cushion insert was deflected twice to $75 \pm 5\%$ of its original height by use of special plates and weights. The specimen was then allowed to rest for a period of $10 \pm$ five minutes. After the rest period, the indenter foot was brought into contact with the specimen and a load of one pound was applied. The height of the specimen was measured with a one-pound pre-load as an initial condition. The specimen was then compressed to 25% of the initial height and the load recorded after one minute of compression at the 25% deflection value. The same procedure was followed for 50, 65, 75, 80, and 85% load deflection values.

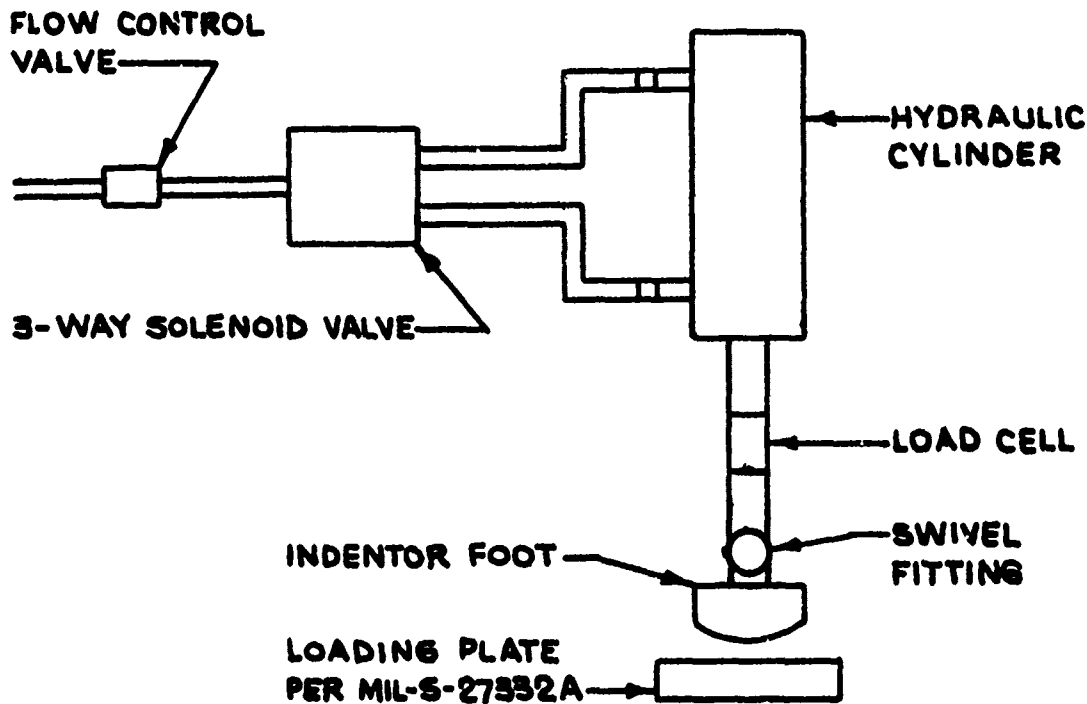
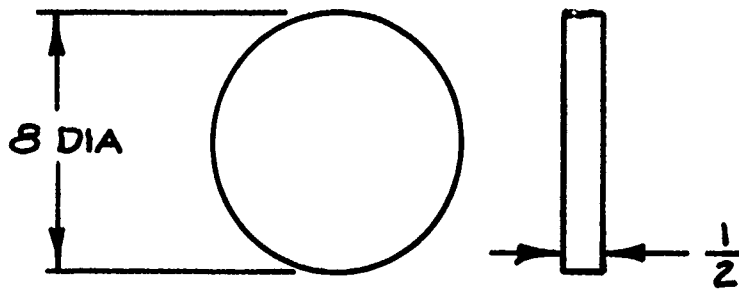
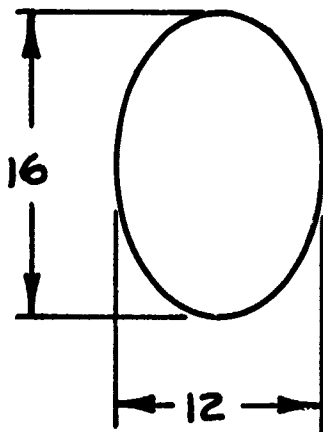

FIGURE 70
STATIC TEST RIG USED TO
OBTAIN LOAD-DEFLECTION CURVES

NOTE: DIMENSIONS IN INCHES, NO SCALE



50 IN² FLAT PLATE



SINGLE

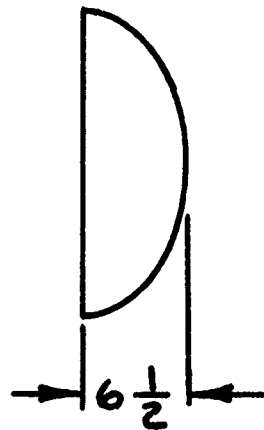

ELLIPSOID

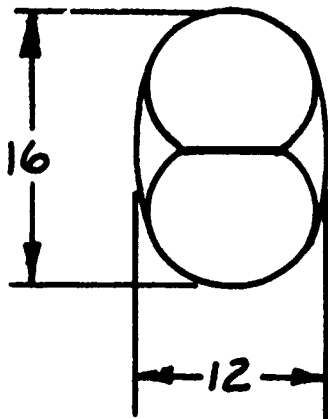

DOUBLE

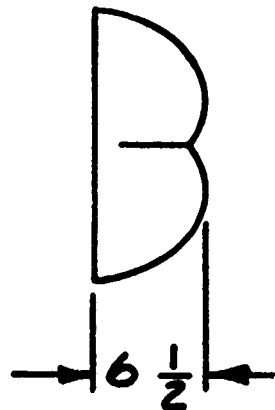

ELLIPSOID

FIGURE 71
INDENTOR FEET USED IN STATIC TESTS OF SEAT CUSHIONS

DYNAMIC REBOUND TESTS

An impact pendulum, shown in Figure 72, was used to obtain dynamic rebound and damping data. The damping coefficient estimate is obtained by comparing the drop height to the rebound height of the pendulum arms.

The effective mass of the pendulum arm was 55 pounds. This value was obtained by impacting the arm into a coil spring with a known stiffness. The time that the pendulum arm was in contact with the spring was taken to be 1/2 of the natural period of the spring-mass system. Doubling this value and finding the reciprocal gives the approximate natural frequency of the arm and spring combination. Since the stiffness of the spring was known, the effective mass of the pendulum arm could be calculated and turned out to be 55 pounds.

Instrumentation consisted of a potentiometer mounted near the pendulum shaft. Coupling was obtained through a mechanical device which tracked the pendulum arm down to the impact into the cushion specimen and continued back up through the maximum rebound point of the pendulum arm. The mechanical coupling remained at the maximum rebound position while the pendulum arm was stopped manually by the technician. The potentiometer signal was directly proportional to the maximum pendulum arm rebound position, and the height of the indenter foot could be calculated through conventional trigonometric methods.

The drop height and rebound height give an estimate of the critical damping ratio through the following formula:

$$\bar{c} = \frac{1}{2\pi} \ln \left(\frac{x_1}{x_0} \right)$$

- where :
- \bar{c} = critical damping ratio
 - x_0 = drop height of the pendulum
 - x_1 = rebound height of the pendulum arm



FIGURE 72
IMPACT PENDULUM USED IN
DYNAMIC REBOUND TESTS

TUBEROSITY PRESSURE MEASUREMENTS

Because earlier research showed that comfort might be related directly to the pressure on the ischial tuberosities, a pressure transducer was designed and built using capacitance as the reusing variable. Figure 73 illustrates the mechanical and electrical configuration of the transducer. The principle of operation is quite simple. A load applied to the transducer pushes the upper and lower shields closer to the active center plate changing the capacitance of the device. The shields eliminate any effect from an external ground plane or from human body ground or electrostatic charge. Figure 74 shows the transducer mounted on the seat pan of a test seat.

Transducer signals were measured using the diode bridge configuration shown in Figure 75. A 400 μH_2 , 250 volt excitation was used with the transducer. The oscillator used was a commercial device designed to provide a constant product of the frequency times voltage. Therefore, a capacitance change, which resulted in a frequency shift, could be detected as a voltage change. The calibration curve of the transducer, bridge, and oscillator combination is shown in Figure 76, and the complete instrumentation set-up is illustrated in Figure 77.

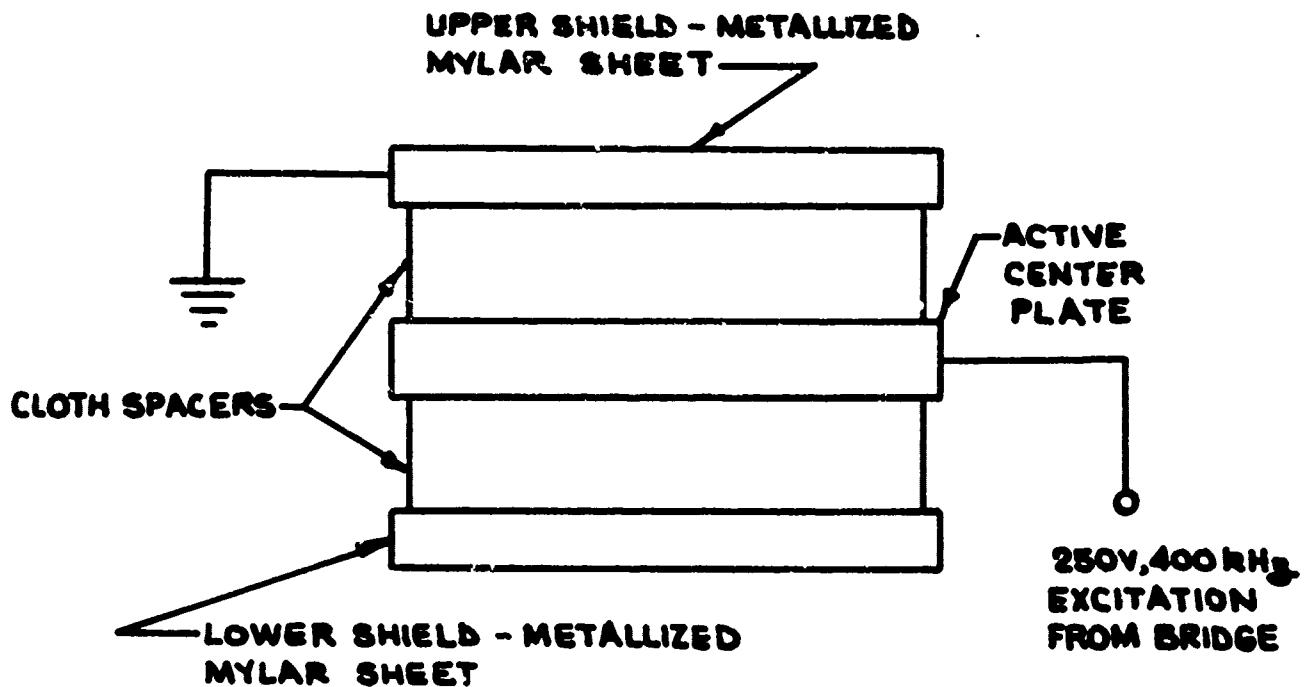

FIGURE 73
 MECHANICAL AND ELECTRICAL CONFIGURATION
 OF THE TUBEROSITY PRESSURE TRANSDUCER

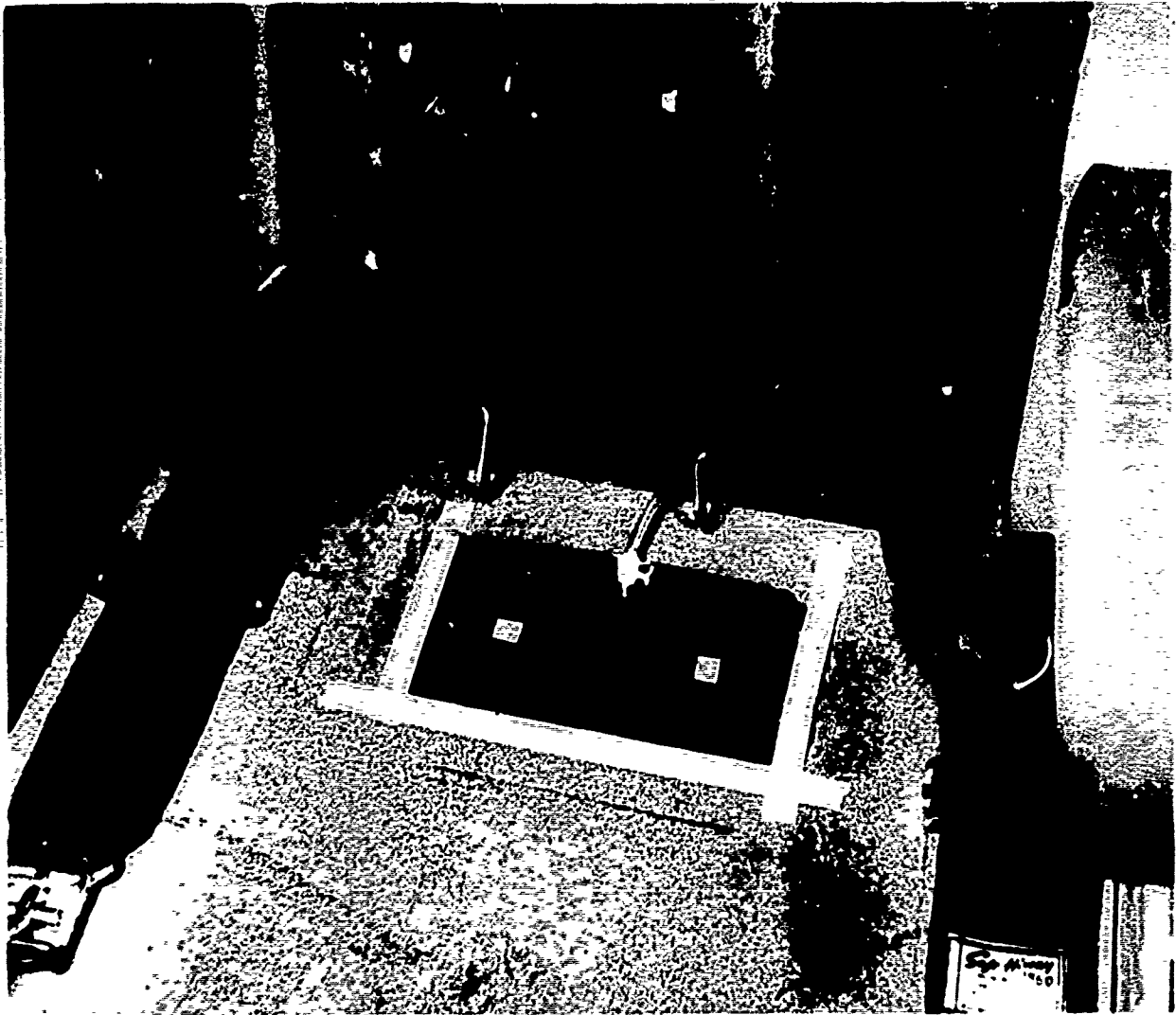

FIGURE 74
ISCHIAL TUBEROSITY CAPACITANCE
PRESSURE TRANSDUCER MOUNTED
ON A TEST SEAT

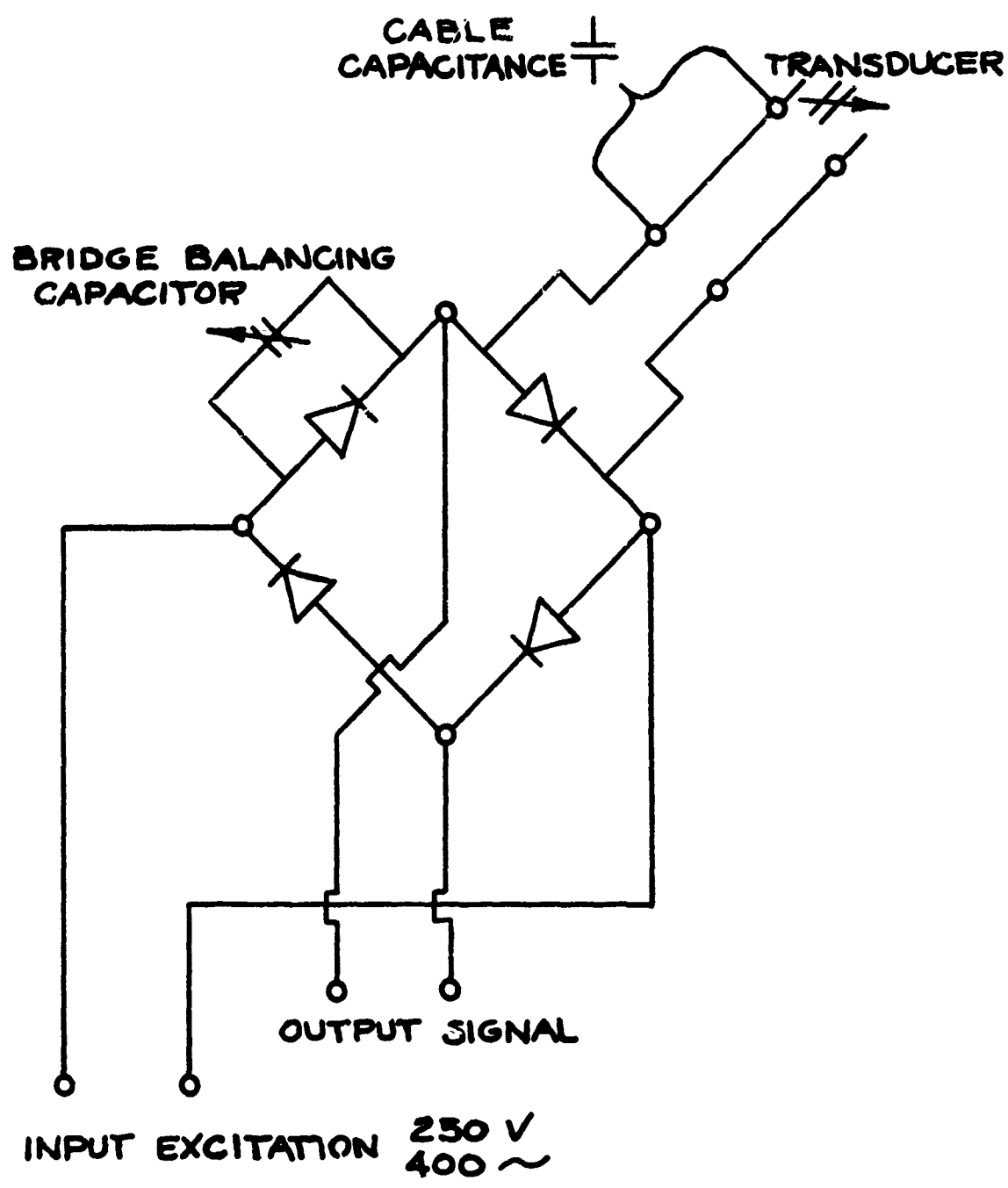

FIGURE 75
DIODE BRIDGE CONFIGURATION USED
IN SENSING CAPACITANCE CHANGES

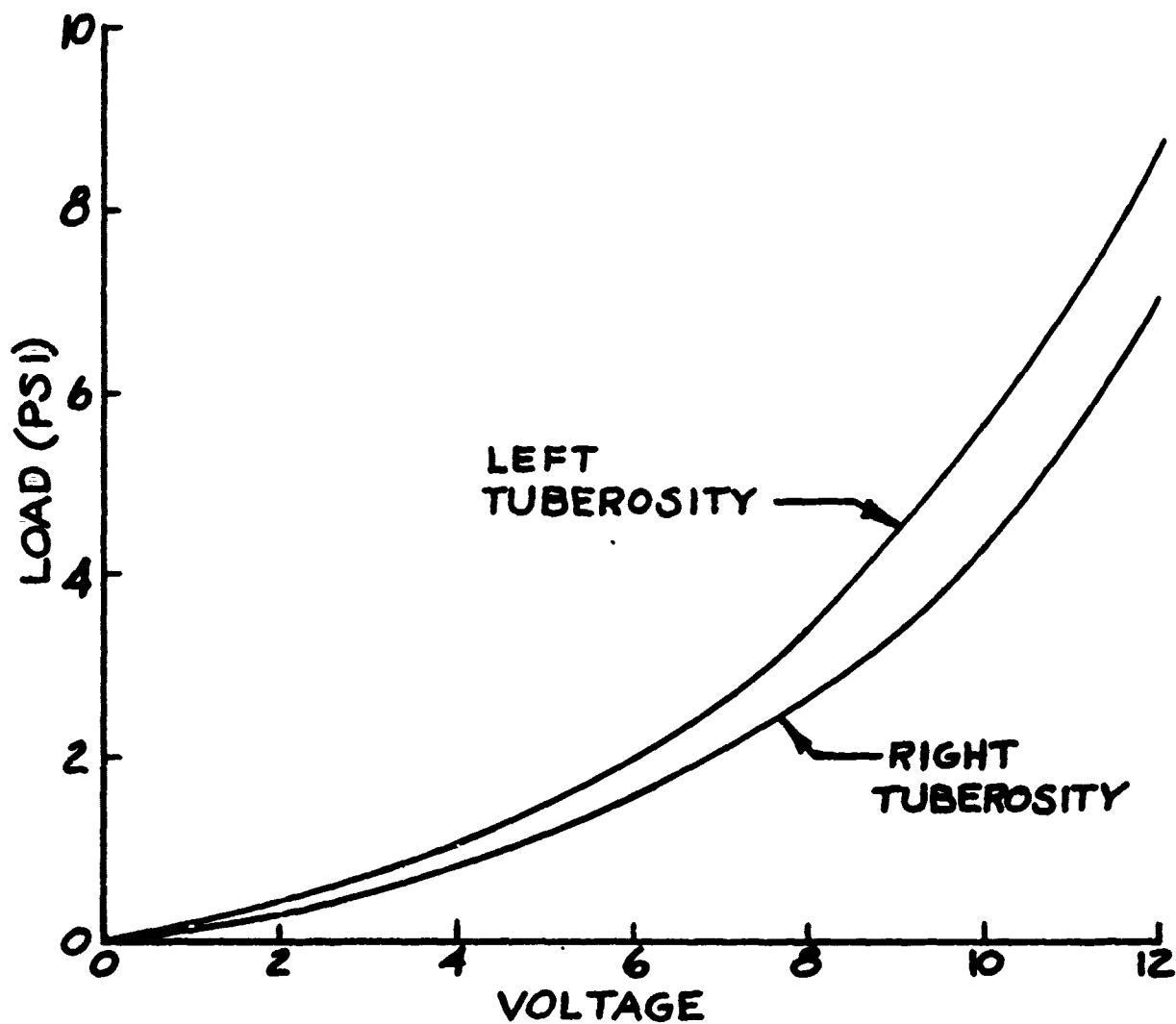

FIGURE 76
PORTION OF CALIBRATION CURVE
FOR TUBEROSITY PRESSURE TRANSDUCERS

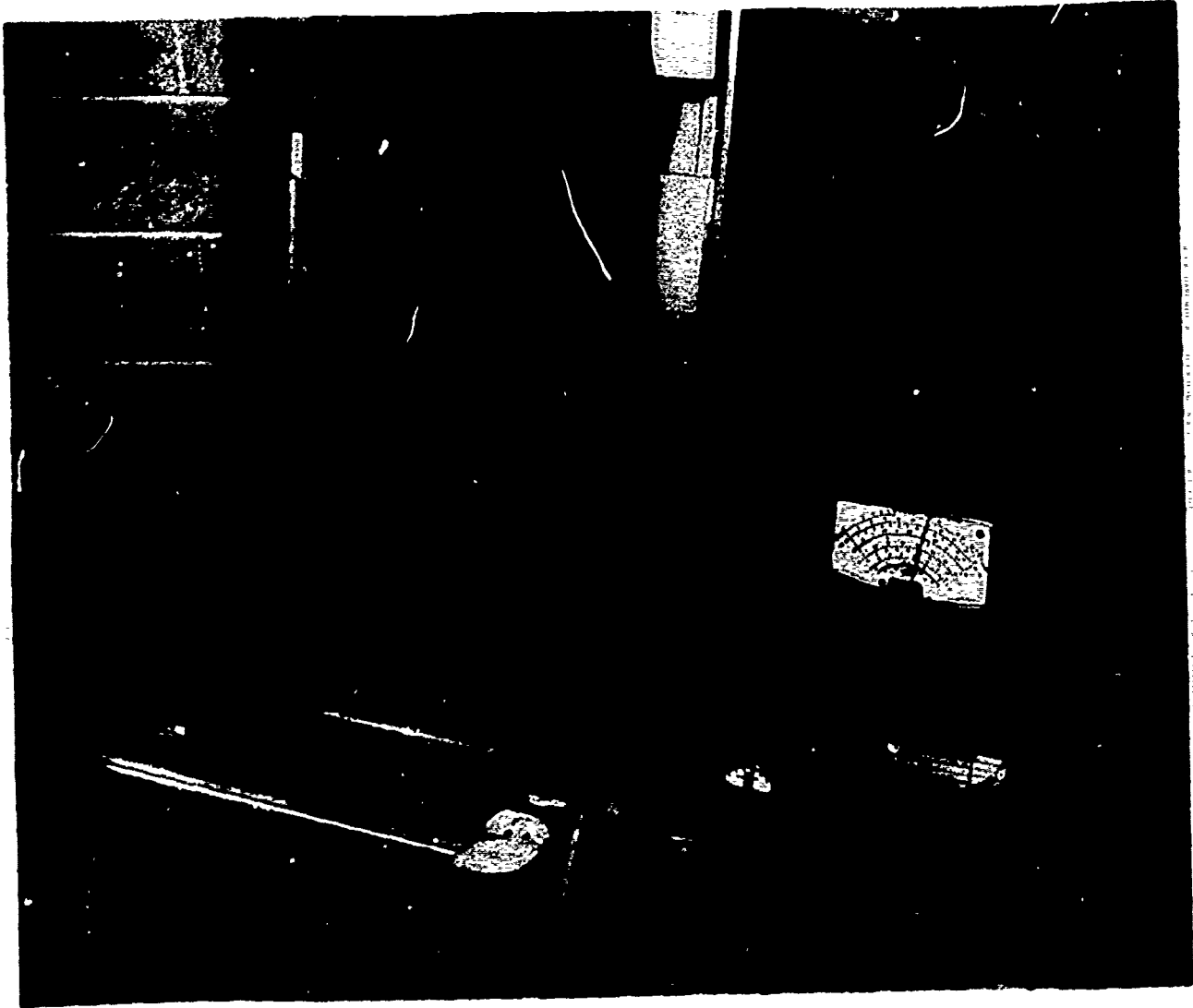

FIGURE 77
TUBEROSITY TRANSDUCER
CAPACITANCE BRIDGE UNIT, AND VTVF
READ-OUT AS USED WITH THE TLST SEAT

COMFORT TESTS

Subjective estimates of comfort were obtained in test seats constructed using MIL-S-5822 (USAF) as a guide. A photograph of the complete seat is shown in Figure 78. Foot rests, arm rests, and a head rest were provided. The head rest was adjustable over a 17-inch range vertically and could also be adjusted in the fore-aft direction over a range of 6 inches. However, the head rest height was held constant for all the tests in the present program, the fixed position being 41.5 inches above the floor. Subjects were positioned vertically in the seat by placing spacers between the seat pan and the bottom part of the seat structure.

The foot rests were adjustable over a range of 18 inches in the fore-aft direction and were positioned for each subject in accordance with a procedure described later in this report. The arm rests were adjustable over an 8-inch range in the vertical direction and were padded. Adjustment of the arm rests was made to the most comfortable position as judged by each subject. The plywood seat pan was adjustable in the vertical direction by means of 1", 2", and 3" removable spacers.

In general, every effort was made to simulate the normal flying position of an air crew member, and subjects were instructed to maintain an upright position with their feet on the simulated rudder pedals. A shoulder harness and lap belt were provided, and both were adjusted to a snug fit as the subject was seated for the test.

Subjects in the test program were chosen from the student bodies of local junior colleges, universities, and technical schools; however, two of the subjects attended a local high school. The subjects ranged in age from 16 to 22 years of age, and 14 of them completed the series of tests on the polyurethane foam. Subjects were selected on the basis of stature and weight and fell between the 10th and 98th percentiles of the United States Air Force Flying Personnel as reported by Hertzberg, Daniels, and Churchill (29). The limits on stature and weight were selected to represent a segment of the 1950 anthropometric data skewed to the high side based upon verbal information from the Contract Monitor that more recent but unpublished anthropometric data had shown the average 1960 population to be larger than the 1950 sample. Measurements were also made of the sitting hip breadth of the subject, and the breadths represented a range from the 13th to the 81st percentile. All anthropometric measurements were made prior to the beginning of the actual comfort test sessions.

Immediately preceding or following the final test session, measurements were made of the sitting weight of the subjects with legs extended and with legs tucked, data presented earlier in this report. The total weight of the subject in the standing position was also obtained at the final session.

The test procedures began prior to the arrival of subjects for test sessions. The seat pan height and foot rests were adjusted prior to the arrival of the subjects based upon the adjustments made during the subject's initial sitting session. When the subject arrived at the test site, he was given a pre-test questionnaire to fill out, after which the subject was instructed to remove

his wristwatch and anything he was carrying in his back pockets which could influence his comfort once seated. The purpose of the pre-test questionnaire was to ascertain the subject's general physical condition and feelings prior to beginning the tests. Following this, the subject was placed in the test seat, and was told to put on the shoulder harness and lap belt, which were then adjusted to a snug fit. A check was made to insure that the subject's eyes were aligned with a present mark on the head rest. The foot rests were also checked to insure that the subject's knees were slightly bent and that he could pass his hand between his thigh and the front lip of the seat pan.

After all the seating adjustments were completed, the subject was given instructions for the test as follows:

This is a test of seat cushions for the Air Force. You are allowed to read and study during the test, but you are not allowed to perform other activities which involve excessive movement. If you want to write you must use a clip board held in your lap.

You are to remain seated until the discomfort becomes unbearable to you. When you want to get out of the seat, tell me.

Questionnaires will be given to you from time to time. Please answer them to the best of your ability. If you have any questions on what the questionnaire means, ask me.

Do you have any questions?

Here is the first questionnaire.

After reading the instructions to the subject, the experimenter presented him with the first hourly test questionnaire. Administration of the hourly test questionnaire was repeated at the end of the first hour and every hour thereafter until the end of the four-hour test period with each questionnaire numbered successively beginning with Number 1, which was given at zero hours, up to Number 5 which was given at the four-hour point.

The four-hour time interval was selected based upon Slechta et al's results (25). Only one additional measure is obtained by keeping subjects in the seat longer than four hours, that is, the time at which they leave the seat. In the present study an attempt was made to use as efficient a test procedures as possible, since a large number of cushions and materials were to be tested. The results of the comfort test program, to be presented shortly, indicate that this goal was achieved.

At the end of the fourth hour of testing or when the subject felt that he could no longer tolerate the discomfort of the seat, he was asked to fill out a post-test questionnaire.

Just before the beginning of the final test session with each subject, tuberosity pressure measurements were made using the equipment described earlier.

The pressures were obtained on each of the cushions tested, and also on the plywood seat pans without a cushion. Tuberosity pressures were obtained on both the left and right buttocks for each cushion condition.

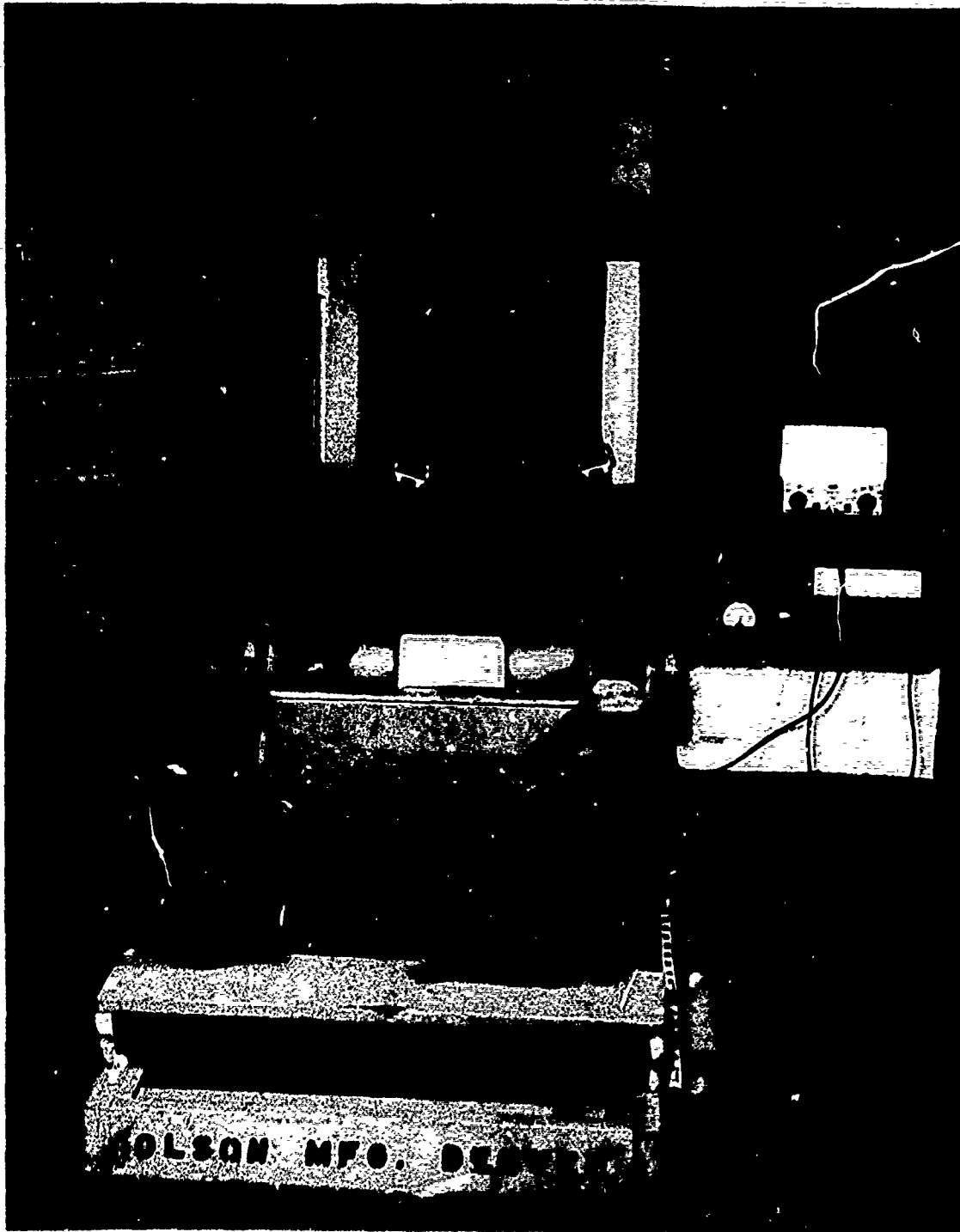

FIGURE 78
COMFORT TEST SEAT

Subject _____
Date _____

SEAT EVALUATION PROGRAM PRE-TEST QUESTIONNAIRE

The questions listed in this questionnaire are meant to provide information about your general states of health, comfort, fatigue, etc., before the seat test is given. Think carefully about each question before you answer it.

A. Personal History

1. Do you now feel discomfort because of any of the following conditions:

Allergies	_____	Dental Trouble	_____
Headaches	_____	Intestinal Trouble	_____
Earaches	_____	Respiratory Trouble	_____
Visual Fatigue	_____	Dizziness	_____
Sinus Trouble	_____	Skin Irritations	_____
Colds	_____	Other	_____

COMMENTS:

2. Indicate the number of hours of sleep you had during the last two nights.

Hours last night _____
Hours the night before last _____

COMMENTS:

B. Condition Immediately Prior to Test

1. How would you rate your state of hunger at this time?

Uncomfortable Full	_____
Full	_____
Just right	_____
Hungry	_____
Uncomfortably Hungry	_____

COMMENTS:

2. Do you feel any stiffness or soreness in the muscles of any of the following regions of the body:

Neck	_____	Abdomen	_____
Arms	_____	Legs	_____
Back	_____	Other	_____
Chest	_____		

COMMENTS:

3. How would you describe the room temperature at this time?

Too hot _____
Warm _____
Just right _____
Cool _____
Too cold _____

COMMENTS:

4. Is your clothing comfortable?

Yes _____
No _____

COMMENTS:

5. Does your clothing offer discomfort in any of the following regions of the body?

Neck	_____	Crotch	_____
Wrists	_____	Buttocks	_____
Under the arms	_____	Feet (shoes)	_____
Waist	_____	Other	_____

COMMENTS:

SEAT EVALUATION PROGRAM TEST QUESTIONNAIRE

Subject _____ Date _____
Seat No. _____
Seat Test No. _____
Question No. _____
Experimenter _____

Answer the following questions to the best of your ability. If the meaning of any question is not clear, do not hesitate to ask the experimenter to explain it.

You will be given this same questionnaire from time to time throughout the experiment. This means that you will be answering these same questions periodically. Do not let your answers to the same questions on previous questionnaire presentations influence your judgment at any time, but try to answer the questions on the basis of how you feel at the moment. Sometimes you may find that your answers do not change. On other questions or at other times your impressions may change with continued experience in the seat. Remember that the important thing is how you feel at the moment; not how you may have felt before.

A. In the questions listed on this page, try to evaluate this seat in terms of the comfort you anticipate it will provide.

1. What is your impression of the degree of comfort that this seat provides at the moment?

- a. _____ It is the most comfortable seat I have ever sat in.
- b. _____ It is extremely comfortable.
- c. _____ It is moderately comfortable.
- d. _____ It is mildly comfortable.
- e. _____ It is neither comfortable nor uncomfortable.
- f. _____ It is mildly uncomfortable.
- g. _____ It is moderately uncomfortable.
- h. _____ It is extremely uncomfortable.
- i. _____ It is so uncomfortable that I cannot tolerate it.

2. At this moment, what is your estimate of the number of additional hours that you could sit in this seat before an intense desire to get out of it develops?

_____ hours

B. Evaluate this seat on the basis of how you feel now. This section deals with your state of comfort or discomfort at the moment. Do not evaluate the seat on the basis of past or future (anticipated) comfort.

1. Describe the degree of discomfort that you feel at this time in the following body regions.

	None	Slight	Moderate	Severe	Very Severe	Intol- erable
a. Neck	_____	_____	_____	_____	_____	_____
b. Shoulders	_____	_____	_____	_____	_____	_____
c. Back	_____	_____	_____	_____	_____	_____
d. Buttocks	_____	_____	_____	_____	_____	_____
e. Thighs	_____	_____	_____	_____	_____	_____
f. Legs	_____	_____	_____	_____	_____	_____

2. Describe the sensations you feel in the following body regions. If none of the sensations listed apply to a particular region, leave a blank.

	Excessive Pressure	Stiff- ness	Ache	Soreness	Prickling Sensation	Numbness
a. Neck	_____	_____	_____	_____	_____	_____
b. Shoulders	_____	_____	_____	_____	_____	_____
c. Back	_____	_____	_____	_____	_____	_____
d. Buttocks	_____	_____	_____	_____	_____	_____
e. Thighs	_____	_____	_____	_____	_____	_____
f. Legs	_____	_____	_____	_____	_____	_____

3. Evaluate the following characteristics of this seat. Put a check mark next to the statement which applies.

- a. The seat cushion is: _____ too firm
 _____ just right
 _____ too soft
- b. The seat cushion is: _____ too wide
 _____ just right
 _____ too narrow
- c. The seat cushion is: _____ too long
 _____ just right
 _____ too short
- d. The seat cushion is responsible for excessive pressure exerted on: _____ the buttocks
 _____ the base of the spine
 _____ the thighs
 _____ no particular area

- e. The back cushion is:
_____ too firm
_____ just right
_____ too soft
- f. The back cushion is:
_____ too wide
_____ just right
_____ too narrow
- g. The back cushion is:
_____ too long
_____ just right
_____ too short
- h. The back cushion gives poor support to:
_____ the shoulders
_____ the middle of the back
_____ the small of the back
_____ no particular area

If there is a headrest, answer the following:

- a. The headrest is:
_____ too firm
_____ just right
_____ too soft
- b. The headrest is:
_____ too wide
_____ just right
_____ too narrow
- c. The headrest is:
_____ too high
_____ just right
_____ too low
- d. The headrest is:
_____ too far forward
_____ just right
_____ too far back

If there are armrests, answer the following:

- a. The armrests are:
_____ too long
_____ just right
_____ too short
- b. The armrests are:
_____ too wide
_____ just right
_____ too narrow
- c. The armrests are:
_____ too close together
_____ just right
_____ too far apart
- d. The armrests are:
_____ too high
_____ just right
_____ too low

C. Extrinsic discomfort. Evaluate your discomfort as it may be affected by the things listed below.

1. Do you feel any temperature discomfort? Yes
 No

2. Is this discomfort due to any of the following reasons?

The room temperature is too high
The room temperature is too low
My clothing is too heavy
My clothing is too light

3. Does your clothing restrict you in any of the following places?

Wrists	<input type="checkbox"/>	Crotch	<input type="checkbox"/>
Underarms	<input type="checkbox"/>	Buttocks	<input type="checkbox"/>
Neck	<input type="checkbox"/>	Feet (shoes)	<input type="checkbox"/>
Waist	<input type="checkbox"/>	Underwear (ill fitting)	<input type="checkbox"/>

4. Do you feel any discomfort due to the following conditions?

Headache	<input type="checkbox"/>	Hunger	<input type="checkbox"/>
Sinus Trouble	<input type="checkbox"/>	Indigestion	<input type="checkbox"/>
Cold	<input type="checkbox"/>	Nausea	<input type="checkbox"/>
Earache	<input type="checkbox"/>	Perspiration	<input type="checkbox"/>
		Other	<input type="checkbox"/>

SEAT EVALUATION PROGRAM POST-TEST QUESTIONNAIRE

Subject _____ Date _____

 Seat No. _____

 Seat Test No. _____

 Question Period _____

 Experimenter _____

This part of the questionnaire is meant to provide information about your general evaluation of the seat and suggestions for improving the comfort and utility of the seat. Think carefully about the questions before answering them.

A. Evaluation of the comfort characteristics of the seat.

1. What, if any, changes could be made in this seat to make it more comfortable for use over long periods of time?

- a. The seat cushion should be:
- | | |
|----------|-------|
| softer | _____ |
| firmer | _____ |
| longer | _____ |
| shorter | _____ |
| wider | _____ |
| narrower | _____ |

COMMENTS:

b. The shape of the seat should be:

- | | |
|--|-------|
| contoured on its surface to fit the buttocks | _____ |
| contoured on its surface to fit the thighs | _____ |

COMMENTS:

c. The seat back cushion should be:

- | | |
|----------|-------|
| softer | _____ |
| firmer | _____ |
| longer | _____ |
| shorter | _____ |
| wider | _____ |
| narrower | _____ |

COMMENTS:

d. The shape of the seat cushion should:

- | | |
|--|-------|
| offer more support to the small of the back | _____ |
| offer more support to the middle of the back | _____ |
| offer more support to the shoulders | _____ |

COMMENTS:

e. If armrests are present, evaluate them in terms of the following:

- They should be:
- longer _____
 - shorter _____
 - wider _____
 - narrower _____
 - higher _____
 - lower _____
 - further apart _____
 - closer together _____

COMMENTS:

f. If a headrest is present, evaluate it in terms of the following:

- It should be:
- firmer _____
 - softer _____
 - lower _____
 - higher _____
 - wider _____
 - narrower _____
 - further forward _____
 - further back _____

COMMENTS:

B. This part of the questionnaire gives you an opportunity to make any comments that you wish to make about the seat, the seat test, your comfort state, and to offer any suggestions that you like. Write freely and in as much detail as possible. You may continue your comments on the back of this page.

C. Place a check mark somewhere along the scale below to show how you would rate this seat in terms of the comfort it affords. Record your impressions, taking everything in general into account.



Intolerable
Discomfort

Neutral

Ideal
Comfort

REFERENCES

1. Latham, F., "A Study in Body Ballistics"; Proceedings of the Royal Society, B, Vol. 147, pp. 121-139.
2. Bondurant, Stuart, Optimal Elastic Characteristics of Ejection Seat Cushions for Safety and Comfort, WADC Technical Note 58-260, Wright Air Development Center, Wright-Patterson Air Force Base, Ohio; 1958, AD 203 384.
3. Hodgson, V. R., Lissner, H. R., and Patrick, L. M., "Response of the Seated Human Cadaver to Acceleration and Jerk With and Without Seat Cushions.", Human Factors, Vol. 5, pp. 505-523; October 1963.
4. Whittenberger, R. K., Improved Seat and Back Cushions, WADC TR 59-376, Aerospace Medical Laboratory, Wright-Patterson Air Force Base, Ohio; 1959, AD 233 446.
5. Glaister, D. H., Properties of Polyurethane Foams in Relation to Their Use as Ejection Seat Cushion Materials, Flying Personnel Research Committee, Report 1184, Air Ministry, 1961.
6. Goldman, D. E. and von Gierke, H. E., "Effects of Shock and Vibration on Man", Chapter 44, Vol. 3, in C. M. Harris and C. E. Crede, editors, Shock and Vibration Handbook; New York: McGraw-Hill Book Co., 1961.
7. Payne, P. R., Personnel Restraint and Support System Dynamics, AMRL-TR-65-127, Aerospace Medical Research Laboratories, Wright-Patterson Air Force Base, Ohio; 1965, AD 624 487.
8. Payne, Peter R., A General Cushion Theory, Working Paper No. 149-2, Revision A, June 1968, Payne Division, Wyle Laboratories, Rockville, Maryland.
9. Brown, R. W. and Dickinson, H. C., "Criteria are Set for Riding Comfort", SAE Journal, Vol. 37, pp. 20-23; 1935.
10. Akerblom, B., The Main Principles of Restful Sitting and Their Significance in the Construction of Comfortable Seats (Paper presented at the Ergonomics Research Society, April 18-20, 1951, University of Birmingham, Birmingham, England).
11. Cumberland, C. H. and Bowey, G. S., "Passenger Seats for Aircraft", Aircraft Engineering, Vol. 22, pp. 250-255; September 1950.

REFERENCES (CONT.)

12. Dreyfuss, H., "Seats for People" Machine Design, Vol. 76, pp. 152-157; November 20, 1960.
13. Hertzberg, H.T.E., Contoured Seat for the Top of an Experimental Rigid Dingby Box, TSEAA-670-9, Aeromedical Laboratory, Wright-Patterson Air Force Base, Ohio; 1947, ATI 139 061.
14. Hertzberg, H.T.E., Contoured Seat for the Top of an Experimental Rigid Dingby Box, Report No. 2, MCREXD-670-9D, Engineering Division, Air Material Command, Wright-Patterson Air Force Base, Ohio, 1949, ATI 67-990.
15. Hertzberg, H.T.E., "Some Contributions of Applied Physical Anthropology to Human Engineering", Dynamic Anthropometry, R. W. Miner, editor, Annals of the New York Academy of Sciences, pp. 616-629; 1955.
16. Hertzberg, H.T.E., "Seat Comfort", Appendix I to Annotated Bibliography of Applied Physical Anthropology in Human Engineering, R. Hauser, D. Y. Cornog, H.T.E. Hertzberg, WADC TR 56-30, Aero Medical Laboratory, Wright-Patterson Air Force Base, Ohio, 1958, AD 155 622.
17. Dempsey, C. A., "Body Support/Restraint" Product Engineering, Vol. 33, No. 8, pp. 106-115, April 16, 1962.
18. Van Wart, F. D., "Human Factors in Long-Range Aerospace Flight" in Jacobs, H. and Burgess, E., editors, Advances in the Astronautical Sciences, pp. 404-412, Vol. VI, New York, The Macmillan Co.; 1961.
19. Henry, J. P., Use of the Anti-G Suit to Aid in the Relief of Fighter Pilot Discomfort, TSEAA-689-2A, Aero Medical Laboratory, Wright-Patterson Air Force Base, Ohio; 1947.
20. Christensen, E. H., Problems of the Circulation in Different Postures, With Special Reference to the Sitting Position in Work of Low Intensity But Long Duration (Paper presented at the Ergonomics Research Society, April 18-20, 1951, University of Birmingham, Birmingham, England.)
21. Gerd, M. A., "Data on the Behavior and Some Functions of Persons Kept Under the Conditions of Limited Mobility" in Parin, V. V., editors, Aviation and Space Medicine, USA-TT-F-228, pp. 107-111; 1964.
22. Gervais, R. L. and Konradi, G. B., Retention of Human System Capabilities During Space Flight (Paper presented at 14th International Astronautical Congress, Paris, September 1963).

REFERENCES (CONT.)

23. Kohara, Jiro, The Application of Human Engineering to Design - Chair, Bed, Vehicle Seat, Institute of Design, Illinois Institute of Technology; 1965.
24. Kohara, Jiro and Hoslin, Akira, "Fitting the Passenger to the Seat", Industrial Design, Vol. 13, pp. 54-59, November 1966.
25. Slechta, R. F., Wade, E. A., Carter, W. K., and Forrest, G., Comparative Evaluation of Aircraft Seating Accommodations, WADS TR 57-136, Wright Air Development Center, Wright-Patterson Air Force Base, Ohio; 1957, AD 118 097.
26. Wachsler, R. A. and Learner, D. B., "An Analysis of Some Factors Influencing Seat Comfort", Ergonomics, Vol. 3, pp. 315-320; 1959.
27. Engelhardt, R. E., Mills, K. D., and Schneider, K., "Shock and Vibration in Road and Rail Vehicles, Part I. Road Vehicles", Chapter 45, Vol. 3 in D. M. Harris and C. E. Crede, editors, Shock and Vibration Handbook, New York; McGraw-Hill Book Company; 1961.
28. Calcaterra, P. C. and Schubert, D. W., Research on Active Isolation Techniques for Aircraft Pilot Protection, AMRL-TR-67-138, Wright-Patterson Air Force Base, Ohio, October 1967, AD 664 090.
29. Hertzberg, H. T. E., Anthropometry of Flying Personnel - 1950, WADC TR-52-321, Wright Air Development Center, Wright-Patterson Air Force Base, Ohio; 1954, AD 479 53.
30. Coermann, R. R., The Mechanical Impedance of the Human Body in the Sitting and Standing Positions at Low Frequency, ASD-TR-61-492; Wright-Patterson Air Force Base, Ohio, September 1961, AD 413 478.
31. Stech, E. L. and Payne, P. R., Dynamic Models of the Human Body, AMRL-TR-66-157, Wright-Patterson Air Force base, Ohio, November 1969, AD 701 383.