

P-320885 ①

AGARD-R-794

AGARD-R-794

AGARD

ADVISORY GROUP FOR AEROSPACE RESEARCH & DEVELOPMENT

7 RUE ANCELLE 92200 NEUILLY SUR SEINE FRANCE

Processed / ~~not processed~~ by DIMS
 M. Donadio signed 6/29/94 date
NOT FOR DESTRUCTION

175 pp
DEC '93

AGARD REPORT 794

Integrated Airframe Design Technology

(Les Technologies pour
la Conception Intégrée des Cellules)

*Papers presented at a Workshop held by the AGARD Structures and Materials Panel,
in Antalya, Turkey, 19th—20th April 1993.*

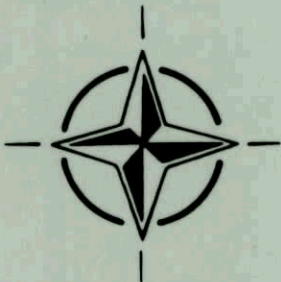

NORTH ATLANTIC TREATY ORGANIZATION

Published December 1993

Distribution and Availability on Back Cover

S RMC 21/12/93

UNLIMITED

2



AGARD

ADVISORY GROUP FOR AEROSPACE RESEARCH & DEVELOPMENT

7 RUE ANCELLE 92200 NEUILLY SUR SEINE FRANCE

AGARD REPORT 794

Integrated Airframe Design Technology

(Les Technologies pour
la Conception Intégrée des Cellules)

Papers presented at a Workshop held by the AGARD Structures and Materials Panel,
in Antalya, Turkey, 19th—20th April 1993.

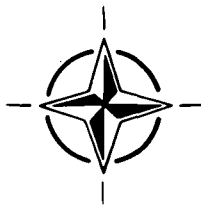

North Atlantic Treaty Organization
Organisation du Traité de l'Atlantique Nord

The Mission of AGARD

According to its Charter, the mission of AGARD is to bring together the leading personalities of the NATO nations in the fields of science and technology relating to aerospace for the following purposes:

- Recommending effective ways for the member nations to use their research and development capabilities for the common benefit of the NATO community;
- Providing scientific and technical advice and assistance to the Military Committee in the field of aerospace research and development (with particular regard to its military application);
- Continuously stimulating advances in the aerospace sciences relevant to strengthening the common defence posture;
- Improving the co-operation among member nations in aerospace research and development;
- Exchange of scientific and technical information;
- Providing assistance to member nations for the purpose of increasing their scientific and technical potential;
- Rendering scientific and technical assistance, as requested, to other NATO bodies and to member nations in connection with research and development problems in the aerospace field.

The highest authority within AGARD is the National Delegates Board consisting of officially appointed senior representatives from each member nation. The mission of AGARD is carried out through the Panels which are composed of experts appointed by the National Delegates, the Consultant and Exchange Programme and the Aerospace Applications Studies Programme. The results of AGARD work are reported to the member nations and the NATO Authorities through the AGARD series of publications of which this is one.

Participation in AGARD activities is by invitation only and is normally limited to citizens of the NATO nations.

The content of this publication has been reproduced directly from material supplied by AGARD or the authors.

Published December 1993

Copyright © AGARD 1993
All Rights Reserved

ISBN 92-835-0729-0



Printed by *Specialised Printing Services Limited*
40 Chigwell Lane, Loughton, Essex IG10 3TZ

Preface

In order to achieve economically viable high-performance aircraft of the future, an integrated aircraft design (IAD) process is required. Integrated airframe design embraces the concept of bringing together all of the aspects of airframe design, including various disciplines such as structures, materials, aerodynamics, controls and manufacturing, from conceptual design all the way through manufacturing. It also includes the sub-disciplines which are involved in each discipline and the interactions these have with one another. Moreover, an IAD process also affects the organizational structure of personnel. Typically, many organizational units are involved in the design process. An IAD approach increases the interactions between these organizations and changes the way they interact with one another. In contrast, the conventional design process is basically sequential or hierarchic in nature and is broken down into many steps which are loosely coupled to one another (i.e., there are few iterations between design steps and limited interaction between organizational units). Moreover, the organizational structure is set up to mimic the conventional sequential design process and it too is sequential. Hence, an IAD process is radically different from the conventional design process.

There is also considerable discipline related advancements that will enable IAD. These fall into two categories: those which reduce engineering time and those which reduce CPU time. In the first category are new modeling techniques which allow rapid construction, refinement and modifications of models. Presently, complex models take exorbitant amounts of time to create and/or modify. This must be reduced through innovative modeling techniques. Also in the first category are improved pre- and post-processing capability to reduce the time needed to understand the output. In the second category are those algorithms which speed up solution times and take advantage of evolving computer technologies and architectures.

It is strongly believed that the recent and future advances in high-performance computer hardware and software systems provide the opportunity to create an IAD process that will allow the process steps and disciplines to interact with one another. Moreover, comprehensive data bases will provide organizational units access to one another's data and models, thereby promoting more interaction between organizations and moving toward a concurrent engineering environment for airframe design. Co-location of personnel with different discipline backgrounds will be required, however, this may take the form of "virtual co-location" brought about by high-speed computer networks and audio-visual aids.

In order to provide a broad-based approach to evaluating and identifying future research and development directions required to provide IAD technology, the First Integrated Airframe Design Technology Workshop, sponsored by AGARD, was held in Antalya, Turkey on April 19th-20th, 1993. This document summarizes the output of that workshop. Presentations are categorized as those on: recent and on-going developments in integrated airframe design at participating aerospace organizations, manufacturing simulation, interdisciplinary integration and developments in computer hardware and software which enable integrated airframe design. In addition, a panel session which capped off the Workshop is also summarized.

Sam Venneri
Chairman
Subcommittee
Integrated Airframe
Design Technology

Préface

L'industrialisation des futurs aéronaves à hautes performances dans des conditions économiquement viables dépend de la mise en place d'un procédé de conception intégrée (IAD). La conception intégrée des cellules englobe le concept du rassemblement de l'ensemble des aspects de la conception des cellules, couvrant différentes disciplines telles que les structures, les matériaux, l'aérodynamique, la fabrication et les contrôles, et ceci des études conceptuelles jusqu'à la fabrication.

Elle comprend également les sous-disciplines qui font partie de chacune des disciplines, ainsi que les interactions entre celles-ci. En outre, le procédé IAD influe sur la structure hiérarchique du personnel. Typiquement, le procédé de conception mobilise plusieurs différentes unités structurelles. L'approche IAD multiplie les interactions entre ces unités et modifie la façon dont elles communiquent entre elles.

Le procédé de conception traditionnel est, au contraire, essentiellement de caractère séquentiel ou hiérarchique. Il est composé de plusieurs étapes qui sont plus ou moins reliées entre elles (c'est à dire qu'il y a très peu d'itérations entre les phases d'une étude et que les interactions entre les unités structurelles sont limitées). D'ailleurs la structure organisationnelle imite le procédé séquentiel traditionnel de conception, car elle est, elle aussi, séquentielle. Le procédé IAD est donc radicalement différent du procédé de conception conventionnel.

Des progrès considérables ont également été réalisés dans des domaines liés à cette discipline, ce qui autorise l'application de l'IAD. Les progrès sont de deux sortes; ceux qui permettent de réduire le temps passé par les bureaux d'études et ceux qui réduisent le temps du traitement informatique. Dans la première catégorie se trouvent les nouvelles techniques de modélisation qui autorisent à la fois une réalisation rapide, de la sophistication et la modification des modèles. A l'heure actuelle, la création et/ou la modification de modèles complexes demande des délais exorbitants. Il s'agit de réduire ces délais par le biais de techniques de modélisation novatrices. A la première catégorie il y a lieu de rajouter une meilleure capacité, tant avant qu'après le traitement, pour la réduction du délai nécessaire à la compréhension des résultats.

Dans la deuxième catégorie se trouvent les algorithmes qui permettent d'accélérer le processus de résolution et qui bénéficient de l'évolution des technologies et des architectures informatiques.

Nous sommes convaincus que les avancées récentes et prévisibles des systèmes informatiques à hautes performances fournissent l'occasion de créer un procédé IAD qui permettra l'interaction entre les disciplines et les différentes étapes du procédé de conception. De plus, des bases de données exhaustives permettront aux organisations d'accéder les unes et les autres aux données et aux modèles existants, encourageant ainsi une plus forte interaction entre les organisations, ce qui laisse prévoir une ingénierie commune concurrente pour la conception des cellules. La co-localisation de personnels de différentes disciplines sera nécessaire, mais ceci pourrait se faire sous la forme d'une "co-localisation virtuelle" grâce aux réseaux informatiques à grande vitesse ainsi qu'aux moyens audiovisuels.

Le premier atelier de travail sur les technologies pour la conception intégrée des cellules a été organisé à Antalya, en Turquie, du 19 au 20 avril 1993, afin d'élaborer une approche tous azimuts de l'identification et l'évaluation des voies futures de recherche et développement dans le domaine des technologies IAD. Ce document résume les résultats des travaux de cet atelier. Les communications présentées sont classées selon les catégories suivantes: les développements récents et en cours dans le domaine de la conception intégrée des cellules au sein des organisations aérospatiales participantes, la simulation de la fabrication, l'intégration interdisciplinaire et les développements informatiques qui permettront la conception intégrée des cellules. Ce document contient aussi le résumé de la session de travail du Panel qui a clôturée l'atelier.

Structures and Materials Panel

Chairman: Mr Roger Labourdette
Directeur Scientifique des Structures
ONERA
29 ave de la Division Leclerc
92322 Châtillon Cedex
France

Deputy Chairman: Dipl.Ing. O. Sensburg
Deutsche Aerospace Structures
Militärflugzeuge LME 202
Postfach 80 11 60
8000 Munich 80
Germany

SUB-COMMITTEE

Chairman: Mr S.L. Venneri
Director, Space Research Division
Office of Aeronautics & Space Tech.
NASA Headquarters, Code RSR
Washington DC 20546
United States

Members

L. Chesta	IT	R. Labourdette	FR
M. Curbillon	FR	H.H. Ottens	NL
W. Elber	US	R. Potter	UK
H. Försching	GE	M. Rother	GE
R. Freymann	LU	A. Salvetti	IT
A.R. Humble	UK	S.G. Sampath	US
J.J. Kacprzyński	CA	O. Sensburg	GE
M. Kilshaw	UK	R.J. Zwaan	NE

PANEL EXECUTIVE

Dr Jose M. Carballal, Spain

Mail from Europe:
AGARD—OTAN
Attn: SMP Executive
7, rue Ancelle
92200 Neuilly-sur-Seine
France

Mail from US and Canada:
AGARD—NATO
Attn: SMP Executive
Unit 21551
APO AE 09777

Tel: 33(1)47 38 57 90 & 57 92
Telex: 610176 (France)
Telefax: 33 (1) 47 38 57 99

Contents

	Page
Preface	iii
Préface	iv
Structures and Materials Panel	v
	Reference
Technical Evaluation Report by J. Housner and J. Krammer	T
SESSION I – STATE AND FUTURE DIRECTIONS	
New Computing Systems, Future Computing Environment, and their Implications on Structural Analysis and Design by A.K. Noor and J.M. Housner	1
Early Manufacturing Considerations in Design by W.C. Kessler, G.C. Shumaker and M.F. Hitchcock	2
Applications of CFD Codes and Supercomputers to Aircraft Design Activities by W. Schmidt and P.W. Sacher	3
Probabilistic Simulation of Concurrent Engineering of Propulsion Systems by C.C. Chamis and S.N. Singhal	4
SESSION II – DESIGN PROCESS	
Frameworks for Integrated Airframe Design by A.L. Shaw	5
The Process Network in the Design and Manufacturing of Aircraft by J. Krammer and A. Rüttinger	6
Integrated Stress and Strength Analysis of Airplane Structures using the Data Processing Tool ISSY by R. Werner, M. Wiedemann and B. Evers	7
Application of Concurrent Engineering Principles to Aircraft Structural Design by J.M. Coyle, M. Droegkamp, T.W. Hesterman, B.L. Matthews and T.M. Wilson	8
Some Practical Problems in Multidisciplinary Design and Optimisation by D.J. Laan, H. Walgemoed, C. Schimmel and R. Houwink	9
Influence of Active Controls on the Design Process of a Large Transport Aircraft by M. Molzow and H. Zimmermann	10
Current and Future Design Methods for Large Transport Aircraft by J.P. Giesing, G.T.J. Tzong and B.E. Schofield	11

	Reference
The Integration of Design and Manufacturing Processes at Alenia DVD by L. Chesta, M. Flaccavento, G. Pollano and F. Staropoli	12
Multi-Disciplinary Coupling for Integrated Design of Propulsion Systems by C.C. Chamis and S.N. Singhal	13
Tendances dans la Méthode de Conception des Cellules d'Avion Militaire (Trends of Design Methodology of Airframe) par C. Petiau	14

Technical Evaluation Report

J. Housner
Mail Stop 240
NASA Langley Research Center
Hampton, Virginia, USA 23602

J. Krammer
Deutsche Aerospace AG
Munich, Germany

Introduction

In order to achieve economically viable high-performance aircraft of the future, an integrated aircraft design (IAD) process is required. Integrated airframe design embraces the concept of bringing together all of the aspects of airframe design, including various disciplines such as structures, materials, aerodynamics, propulsion, controls and manufacturing, from conceptual design all the way through to the final product and its repair and maintenance. It also includes the sub-disciplines which are involved in each discipline and the interactions these have with one another. Moreover, an IAD process also affects organizational structure of personnel. Typically, many organizational units are involved in the design process. An IAD approach increases the interactions between these organizations as well as changes the way they interact with one another. In contrast, the conventional design process is basically sequential or hierarchic in nature and is broken down into many steps which are loosely coupled to one another (i.e., there are few iterations between design steps and limited interaction between organizational units). Moreover, the organizational structure is typically set up to mimic the conventional design process so it too is sequential. An IAD process would be radically different from the conventional design process. It would permit many disciplines to operate in parallel thereby reducing design cycle time.

It is strongly believed that the recent and future advances in high-performance computer hardware and software systems provide the opportunity to create an IAD process that will allow the process steps and disciplines to

interact with one another. Moreover, comprehensive data bases will provide organizational units access to one another's data and models, thereby promoting more interaction between organizations and moving toward a concurrent engineering environment for airframe design. Co-location of personnel with different discipline backgrounds will be required, however, this may take the form of "virtual co-location" brought about by high-speed computer networks and audio-visual aids. This will make it possible to create a more concurrent aircraft design process and consequently, shorten the design and manufacture process.

In order to provide a broad-based approach to evaluating and identifying future research and development directions required to provide IAD technology, the First Integrated Airframe Design Technology Workshop, sponsored by AGARD, was held in Antalya, Turkey on April 19-20, 1993. The workshop consisted of two sessions; one on the state-of-the-art and future directions and the other on the design process itself. Altogether, fourteen presentations were made and a panel discussion concluded the workshop.

The purpose of this report is to evaluate and identify the technology needs and issues that must be addressed in order to achieve integrated airframe design as surfaced at the First Integrated Airframe Design Workshop. The IAD Workshop identified several technical needs. These appear to fall into three categories. First, the need was identified for new methodologies which would be used to provide more accurate data and predictive capability early in the design process. This category includes improved load definition, manufacturing simulation, fluid-structure interaction and treatment of design details. This will require new single and multidisciplinary methodologies. A

second category were those computational utilities required to enable an efficient integrated design system, such as better pre- and post-processing capability to achieve a user friendly environment, improved algorithms which take advantage of emerging computer hardware and architecture to produce quick turn-around solutions, and modularized software that can be updated/replaced as new software modules are developed. Third, there were those needs related to a concurrent engineering environment and those of an organizational nature, such as co-location of multidisciplinary and multi-function personnel. The remainder of this evaluation report is divided into these three areas.

Early Design Needs

There are major benefits in developing methodologies which permit more comprehensive and in-depth analyses early in the design as addressed by J. Coyle of the McDonnell Aircraft Company (8). The sooner design issues are uncovered and addressed within a discipline, the less impact they are likely to have on their own discipline and other disciplines. This can reduce costs dramatically. Methodologies which make it easier to examine design details should be included in an IAD system, since it is often the tedium and length of time required to perform the appropriate computations that is prohibiting. Also, methodologies which lead to better loads definition early in the design process are needed. The theme of meeting early design needs kept recurring throughout the workshop.

An overview of the actual state-of-the-art in IAD in connection with the process chain was given by Petiau from Dassault Industries (14). This presentation explained the current airframe design methodology for a combat aircraft. Emphasis was placed on the necessity for efficient computational tools: a CAD tool (e.g., CATIA) with a common data base for the geometrical data, an integrated analysis tool (e.g., ELFINI) for managing aeroelasticity, loads and, stress and strain coupled with CAD and controlled by a mathematical optimizer. For the design process of the future he gave some trends of the capabilities of new design tools. To achieve cost and time reductions in

the development process, the geometric design must use feature modeling in which parts are defined by their features (e.g., sheet, hole, flanged edge) and no longer by geometric primitives (e.g., points, curves and surfaces). The integrated analysis tools have to use design variables defined by CAD properties and not FEM properties to handle shape and topological optimization issues. IAD should also be extended to cover other disciplines such as flight mechanics, performance, propulsion and flight control systems. As addressed by M. Molzow and H. Zimmerman of Deutsche Aerospace Airbus GmbH (10), control systems must be incorporated into an integrated design system both from a performance and loads point of view. As shown in the presentation by C. Chamis of the NASA Lewis Research Center, (13), integrated computerized simulation capabilities for the propulsion discipline are rapidly developing.

As pointed out in the paper by Laan et al of Fokker Aircraft (9), better loads definition is one of the practical needs of IAD. It requires improvements in the load definition process so that prediction of loads is more rapid and more reliable at an early stage of design. As the design process progresses the loads definition should improve with the design definition. It does not make good sense, nor is it good business, to optimize a design with a severely in-accurate loads definition. As they point out, factors of safety are primarily driven by the uncertainty in the loads definition. A well configured IAD system can do much to improve this situation, since it will result in better models earlier in the design process and hence better load definition. This theme was also seen in the presentation from the McDonnell Douglas Corporation, (11).

The McDonnell Douglas Corporation presentation by Schofield and Giesing, (11), reviewed the work being done in developing an IAD system for future large transport aircraft. Their presentation highlighted the development of an Aeroelastic Design Optimization Program (ADOP) which represents an important step in IAD. Their ADOP code utilizes finite element modeling so as to achieve a single master model throughout the design process. As with the presentation from Fokker Aircraft, they show the need for better load definition early in

design. They have included aeroelasticity into ADOP since structural flexibility strongly affects loads. An integrated system should also aim at using CFD capability coupled to FEM structural capability. By introducing FEM early in design, a master model can be first assembled early in design and then evolved from conceptual design through manufacture.

Application of Computational Fluid Dynamics (CFD) codes in IAD was covered in the joint presentation by Schmidt and Rubbert, (3), of Deutsche Aerospace AG and Boeing Commercial Aircraft, respectively. In order to make better decisions early in the design process, aero-structural coupling must be accounted for, since aero generated loads depend on wing deformations. Design of economical high-performance aircraft will require coupled CFD and structural FEM analyses. It was suggested that use and acceptance of CFD generated results may be greater in Germany than in other NATO nations. If so, sharing of knowledge with other nations would be beneficial. Pacing technology items in CFD are turbulence and high angle of attack simulations. CFD codes do not replace prototype aircraft nor wind tunnels, but augment experimental data to provide insight and understanding, and when coupled with FEM structural models, provide aeroelastic loads and flutter instabilities. CFD codes are now being coupled to flexible FEM modeled structure. The developments in this area must be a part of any IAD system.

The need to consider manufacturing issues early in the design process was another thread that ran throughout the workshop. Shumaker and Hitchcock from the Wright Laboratory (2) stressed the need to think through design and manufacturing considerations, identifying high risk areas and show stoppers early in the design process. Also, computational tools exist for detail design, but few exist for conceptual or preliminary design. Computational capability should be established which allows design detail to be incorporated earlier in the design process. Design details strongly influence manufacturing and hence, if not identified early, can lead to potential difficulties arising late in the design process where they can become quite costly. In addition, capability is needed to create "virtual manufacturing" simulations so that manufacturing can be placed

early in the design process to trade-off manufacturing costs with aircraft performance and other issues, and to identify manufacturing innovations to make a weight or performance savings feasible. Virtual manufacturing capability would therefore answer questions such as, "Can X performance be built for Y cost"? The benefits of such a system are predicted to be a 50% risk reduction through producibility verification.

The necessity of taking into account the manufacturability early in the design process was also highlighted in the paper of Krammer and Ruettinger, (5), from Deutsche Aerospace. They pointed out that for an efficient integrated aircraft design, the introduction of sophisticated software tools in the different disciplines is necessary, but not sufficient. To increase the overall productivity it is necessary to analyze first the existing processes and then redesign them and support them with adequate design software (e.g., the Lagrange structural optimization program.) They showed that the inclusion of manufacturing constraints in the optimization loop, generated by the simulation of an automatic tape laying process and the simultaneous consideration of other relevant design requirements such as stress, static aeroelastics and flutter, makes it possible to get manufacturable structural designs with minimized weight.

Capabilities to provide sensitivity type information are also highly desirable. These include methods to compute sensitivity derivatives and probabilistic data. Probabilistic capabilities, which were addressed by C. Chamis of the NASA Lewis Research Center, (2), represent an emerging technology which provides more information than traditional sensitivity derivatives because they allow the consideration of large changes in design variables, tolerances, loading unknowns and other uncertain quantities. These methods provide reliability data to identify those manufacturing and design items which significantly contribute to performance risk and cost. Then those elements which will likely have the greatest payoff can be attacked early in the design process. Of course, generation of reliability data requires more input than a comparable deterministic code, however, studies have shown that with

remarkably little additional data, much valuable information can be extracted.

Deutsche Aerospace Airbus GmbH in, a presentation given by Werner and Evers (7) shared their experiences in developing and working with their Integrated Structural Mechanics System called ISSY. This software system provides integration of stress and strength analyses with a structural data base. They found that integration eliminated much overlapping and duplication in the design process. For example, by changing a design quantity in ISSY, appropriate changes are made to FEM models used for stress analysis and models used for strength analysis. This is accomplished through software module translators. For strength analysis the translators reference separate frame, stringer, skin panel and other component special purpose analyses and models while for stress, the translators reference FEM node geometry and element designators.

Another important aspect of IAD was presented by Deutsche Aerospace GmbH (10) which addressed the importance of aeroservoelastic effects and its multiple interactions in the design of an actively controlled transport aircraft. The influence of an electronic flight control system (EFCS) on loads and flutter velocity was shown. The challenges in connection with system failures were also discussed. It was pointed out that for a future multi-disciplinary optimization process, data for stiffness, aerodynamic and control systems must be better synchronized in the early design phases in order to obtain a balanced design. It is necessary to predict the effects of each discipline on the aircraft's handling qualities, loads, flutter, structural response and control systems. This is an ambitious task for an automated integrated airframe design system.

Computational Utilities for Integrated Design

Since an IAD system is for the use of engineering practitioners, it is imperative that it have a user-friendly "windows-like"

front-end pre-processor with graphical capability to verify modeling. Model mesh generators presently exist although there is some tuning still needed in order to avoid severely distorted finite elements. Adaptive meshing, where the mesh changes with structural behavior are presently being developed, but need better error and refinement indicators before being placed into an IAD system. These capabilities are very much needed because engineers still spend too much time modeling instead of analyzing and designing.

An integrated system will require a considerable amount of input data, but it will also generate enormous amounts of output data. Engineers need new utility tools to assimilate all this data. Virtual reality may be an emerging technology which could be adapted to an IAD system to provide new ways of examining output data. The form that future computing hardware systems will take, will play an integral part in identifying how to put together an integrated system.

A look at the future computing environment was provided by Noor and Housner (1) from the University of Virginia and from the NASA Langley Research Center, respectively. Future computing systems will likely consist of heterogeneous workstation clusters closely networked together in concert with a massively parallel computer for those operations which can benefit from parallelism. Execution time on the massively parallel computers is expected to exceed one trillion floating point operations per second (teraflop) capability by the end of the decade. Communication between workstations will likely be through Fiber Distributed Data Interface (FDDI) operating at 100 megabits per second or High-Performance Parallel Interfaces (HIPPIs) operating at a gigabit per sec. Wireless Local Area Networks (LANs) may also become a reality in the near future. Graphical display capability will also increase enormously and new display technologies such as virtual reality will be utilized. Developments in computer hardware and software have already made "paperless aircraft" a reality for some organizations. It is expected that this will be true of all aircraft organizations in the near future.

Environment and Organizational Structure for Integrated Airframe Design

In order to integrate the data which are produced by the different disciplines and to optimize the design process, a relational common data base for lofts, loads, aerodynamic data and other engineering data was implemented at Alenia (12) as discussed by L. Chesta. They created a distributed workstation and X-terminal environment especially suitable for the interactive handling of data such as the generation of the geometric model (e.g. CATIA) or the pre- and post-processing of FEM and CFD generated data.

Integrated airframe design also requires changes in organizational structure. Shaw from British Aerospace (5) provided insight as to what they are doing to bring about IAD through a concurrent engineering environment. Concurrent engineering requires an organization composed of multi-disciplinary and multi-function teams which employ computer aided engineering tools to make design decisions. Because of the multi-disciplinary and multi-functional character of the teams, design issues, which conventionally are considered sequentially, are instead considered concurrently. The currently engineered design makes possible early decisions concerning trade-offs between materials, structural performance, cost and manufacturing, thereby avoiding expensive design changes, whose need would otherwise become evident later in the design process.

One of the organizational changes discussed by several speakers was the need for co-location of personnel who must form the multi-function, multi-disciplinary teams required in a concurrent engineering environment. Advances in multi-media communication may make the concept of virtual co-location a real alternative.

Summary

A closing workshop panel session helped to summarize the workshop content and to identify the direction and needs in integrated airframe design. The content of the workshop

revealed the present state of integrated airframe design. Well established software codes like the ELFINI code of Dassault, the LAGRANGE code of DASA and the on-going development of McDonnell Douglas' ADOP code point to the importance of such software systems. The use of these and other computational tools in the early phases of the design process was an identified theme of the workshop. Computational tools are needed which can incorporate manufacturing and detail design considerations in the conceptual and preliminary design phases where about 70% of the design decisions are made. For example, the incorporation of manufacturing simulation in the early design phase was strongly emphasized.

It was also the consensus of the attendees that, whereas new individual computational tools are needed, the integration of the computational tools is a critical need. Indeed most of the presentations in the workshop addressed integration. Interfaces between tools in different disciplines must be developed. For example, the interface between structures and manufacturing at the conceptual design phase needs to be addressed so that weight costs of structural design decisions can be traded-off with manufacturing costs. A key factor in tying disciplines together is multidisciplinary design optimization.

The rapid developments in computing hardware coupled with advances in new discipline methodologies and numerical methods will allow enormous strides to be made in predictive capability. It will be possible to handle more complex behavior earlier in the design process in a user-friendly networked workstation environment with high-powered graphics to help assimilate the enormous amounts of data that will be output from future integrated design systems.

One final important item emphasized by the workshop was that organizational changes will be necessary to get the fullest benefit from the interdisciplinary integrated airframe design system and that in some cases, co-location to form interdisciplinary teams may be necessary.

For future workshops, it is recommended that,

- (1) the interaction of engineering processes with other disciplines which influence development and life cycle costs (manufacturability, reparability and maintainability) be addressed and
- (2) the computational developments to enable more comprehensive integrated early design be updated as developments require. This would include, but not be limited to methods for loads definition, coupled aero/structure analysis, modeling enhancements and manufacturing simulation. High-risk/high-payoff approaches could be identified.

Presentations

(In the order of presentation.)

1. "New Computing Systems and Future Computing Environment, and their Implications on Future Structural Analysis and Design", A.K.Noor, University of Virginia, Hampton, Virginia, USA and J.M. Housner, NASA Langley Research Center, Hampton, Virginia, USA.
2. "Early Manufacturing Considerations in Design", W.C. Kessler and G.C. Shumaker, Wright Laboratory, Dayton, Ohio, USA.
3. "Application of CFD Codes and Supercomputers to Aircraft Design", W. Schmidt, Deutsche Aerospace, AG, Munich, Germany and P. Rubbert, Boeing, Seattle, Washington, USA.
4. "Probabilistic Simulation of Concurrent Engineering of Propulsion Systems", C. Chamis, NASA Lewis Research Center, Cleveland, Ohio, USA.
5. "Framework for Integrated Airframe Design", A. L. Shaw, British Aerospace, Warton, UK.
6. "The Process of Network in the Design and Manufacturing of Aircraft", J. Krammer and A. Ruettinger, Deutsche Aerospace AG, Munich, Germany.
7. "Integrated Stress and Strength Analysis of Airplane Structures using the Data Processing Tool ISSY", R. Werner and B. Evers, Deutsche Aerospace Airbus GmbH, Hamburg, Germany.
8. "The Application of Concurrent Engineering Principles to Aircraft Structural Design: J. Coyle", McDonnell Aircraft, St. Louis, MO, USA.
9. "Integrated Design Process at Fokker Aircraft Company", D. J. Laan, H. Walgemoed, C. Schimmel & R. Houwink, Fokker Aircraft B. V., Schiphol, Netherlands.
10. "Influence of Active Controls on the Design Process of a Large Transport Aircraft", M. Molzow and H. Zimmermann, Deutsche Aerospace Airbus GmbH, Bremen, GE.
11. "Current and Future Design Methods for Large Transport Aircraft", B. E. Schofield and J. P. Giesing, Douglas Aircraft Company, Long Beach, CA, USA.
12. "The Design Process at Alenia Defense Aircraft Division", L. Chesta, Alenia, Torino, Italy.
13. "Multidisciplinary Coupling for Integrated Design of Propulsion Systems", C. Chamis, NASA Lewis Research Center, Cleveland, Ohio, USA.
14. "Trends of Design Methodology of Airframes", C. Petiau, Dassault Industries, St. Cloud, France.

New Computing Systems, Future Computing Environment and Their Implications on Structural Analysis and Design

Ahmed K. Noor and Jerrold M. Housner
NASA Langley Research Center
Mail Stop 210
Hampton, Virginia 23681 U.S.A.

SUMMARY

Recent advances in computer technology that are likely to impact structural analysis and design of flight vehicles are reviewed. Brief summary is given of the advances in microelectronics and networking technologies, and in the user-interface hardware and software. The major features of new and projected computing systems, including high-performance computers, parallel processing machines, and small systems are described. Advances in programming environment, numerical algorithms, and computational strategies for new computing systems are reviewed. The impact of the advances in computer technology on structural analysis and design of flight vehicles is described. A scenario for future computing paradigm is presented and the near-term needs in the computational structures area are outlined.

1. INTRODUCTION

Five generations of computers are generally recognized, corresponding to a rapid change in the hardware building blocks from relays and vacuum tubes (1939-1950s), to discrete diodes and transistors (1950s-1960s), to integrated circuits (small and medium scale ICs) (1960s-mid 1970s), to large- and very-large-scale integrated devices (mid 1970s-1990) to the ultra-large-scale integrated devices and powerful microprocessors (1990-present). These generations have increased the speed by more than a trillion times during the last five decades, while dramatically reducing the cost (see Ref. 1 and Fig. 1). A new generation of computers is evolving and is likely to be available before the end of the present decade. The hardware building blocks for the new generation include giga-scale integrated devices, new transistor materials and structures, and optical components. Extensive use will be made of AI technology. Novel forms of machine architecture (e.g., new forms of scalable parallel architectures) will be introduced and will result in a dramatic increase in computational speed. The new century will undoubtedly see more radical changes in both computing technology and computing paradigm, such as heterogeneous processing, artificial neural network machines, purely optical components, and virtual computing on reconfigurable hardware. Virtual computing involves the analysis of an algorithm to identify its computationally intensive inner-loops and then implements those inner-loops in completely reconfigurable hardware.

The opportunities offered by the new and projected computing environment for structural analysis and design are enormous. However, in order to realize the full potential of the new and emerging computing systems, the strong interrelations of numerical algorithms and software with the architecture of the systems must be understood, and special solution methodologies and computational strategies must be developed. The present paper summarizes some of the recent developments in computing systems during the recent past and near-term future; and relates these

developments to structural analysis and design.

A number of previous attempts have been made to predict the characteristics of structural analysis software systems, and the impact of advances in computing systems on the structures technology. The discussion presented herein is an extension and an update of that in Ref. 2.

2. BRIEF REVIEW OF CURRENT AND PROJECTED ADVANCES IN COMPUTER HARDWARE AND NETWORKING TECHNOLOGY

The major developments in computer technology have been, and continue to be, focused on improvements of cost, size, power consumption, speed, and reliability of electrical components. The next generation of computers will be impacted by the developments in three basic areas; namely, hardware components, artificial intelligence, and computer architecture and system design methods. The major advances in hardware components are briefly reviewed in this section, and some of the new computing systems are described in the succeeding sections. The survey given here is by no means complete or exhaustive; the intention is to concentrate primarily on those developments which have had, or promise to have, the greatest impact on structural analysis and design. Discussion is focused on microelectronics and semiconductor technology; memory systems; secondary storage devices; user-interface facilities; and networking.

2.1 Microelectronics and Semiconductor Technology

The most notable advances in hardware components in the last three decades have occurred as a result of developments in microelectronics. Instead of connecting discrete components together by wires to produce a circuit, complete circuit patterns, components, and interconnections are placed on a small chip of semiconductor material. The predominant semiconductor material in use to date is silicon. Better understanding of this material as well as better processing, tooling and packaging techniques enabled the design of fast, dense circuitry. The traditional technology used for high performance logic has been Emitter-Coupled Logic (ECL), which is the fastest of the silicon logic technologies, and continues to be used in most supercomputers. The Complementary Metal-Oxide Semiconductor (CMOS), despite its slower speed, has low power and high component density. Therefore, more gates per chip and fewer chips are used for each logic function than for ECL.

The principal advantages of microelectronic circuits are their reliability, low cost, and low power consumption. The ever-increasing number of devices packaged on a chip has given rise to the acronyms SSI, MSI, LSI, VLSI, ULSI, and GSI, which stand for small-scale, medium-scale, large-scale, very large-scale, ultra large-scale, and giga-scale

integration, respectively. Since 1960 the number of components on a chip has increased continuously. For the case when no differentiation can be made between logic and memory, the progression of development is shown in Fig. 2. The density of logic chips is projected to grow at a slower rate than the density of memory chips (a factor of seven in five years for logic chips, compared to a factor of ten in five years for memory chips). It is anticipated that by the year 2000 the number of components per chip will reach one billion (GSI) - see Ref. 3. The full range of hardware components (computer building blocks) are now available on microelectronic chips; these include memory units, addressing units (i.e., counters and decoders), complete central processing units (CPUs) called microprocessors, and even complete microcomputers (which include the CPU, memory, and input/output functions all residing on a single chip). The net effect of the aforementioned developments has been a sustained reduction in the cost of computing.

Current research is directed towards: a) shrinking of conductor and device dimensions (scaling) to quarter and subquarter micron ($< 0.25 \times 10^{-6}$ m); and b) increasing the speed of logic circuits, to achieve a machine cycle time of the order of 0.5 nsec (0.5×10^{-9} sec).

The first objective (miniaturization of electronic components) can be accomplished by using recent and improved lithography tools for etching element patterns on a chip (including optical, electron beams, ultraviolet (UV) optics, direct-wire electron beam, X-ray, and ion-beam techniques) as well as novel processing technology and fabrication techniques. The improved tools also enable more devices to be manufactured on a given wafer size which can increase the circuit's operating speed and reduce the cost. The use of atomic or subatomic scale devices is also being explored.

Three candidate technologies are likely to achieve the second objective of ultrafast logic circuits. These technologies are based on using: a) new material systems such as gallium arsenide (GaAs), a component semiconductor material, super-conducting materials which do not require liquid helium temperatures (e.g., copper oxides) and diamond; b) multichip modules (MCM), in which unpackaged integrated circuits are mounted on a substrate and connected with very fine wires in order to get as many chips as possible on one module. The ratio of the semiconductor material (e.g., silicon or GaAs) to the integration substrate is usually about 50 percent. MCM in addition to increasing the integrated circuit densities, speed, and reliability, reduces their size and weight (see Ref. 4); c) new transistor structures such as the quantum-coupled devices using hetero-junction-based super lattices; and d) integrated optical circuits.

2.2 Memory Systems

Memory is the most rapidly advancing technology in microelectronics. Recent progress includes development of an entire hierarchy of addressable memories, and of high-speed, random-access memory chips with many bits of data. Each level in the hierarchy represents an order-of-magnitude decrease in access speed, and several orders-of-magnitude increase in capacity, for the same cost (see Ref. 5 and Fig. 3). The techniques of splitting and interleaving among various types of memory hierarchies in individual systems have changed some of the basic concepts of computing itself. Instead of just a few registers in the CPU and a single-level memory, a typical machine may now have:

- a. a number of high-speed, general-purpose registers (in the CPU)

- b. a cache memory (or instruction buffers) for very rapid access to small amounts of data (or instructions)
- c. standard main (central or equivalent) memory
- d. extended memory, directly addressable, but at a lower speed (solid static disks, magnetic disks and tapes, optical disks)
- e. hardware-implemented virtual memory, extending the amount of addressable space, with the help of an auxiliary (backup) memory such as disk arrays.

There are several types of semiconductor memories. These include random-access and read-only memories. In random-access memory (RAM), data can be written into, or read of, any storage location without regard to its physical location relative to other storage locations. Read-only memory (ROM) contains a permanent data pattern stored during the manufacture of the semiconductor chip in the form of transistors at each storage location that are either operable or inoperable. RAM can be either static or dynamic. Dynamic RAM (DRAM) requires constant refreshing to maintain its data, while static RAM (SRAM) does not. However, advances in DRAM permit double the amount of RAM at about the same cost as static RAM, so DRAM is used more frequently. The trends in the DRAM and SRAM chip capacity are depicted in Fig. 4. As can be seen from Fig. 4, the DRAM chips are typically one generation ahead of the SRAM chips. More recently, large capacity DRAM chips with cache subsystems (CDRAM) have been developed.

Other types of memory include sequential access memories (SAMs) and direct-access storage devices (DASDs). In SAM information is accessed serially or sequentially. Examples of SAMs are provided by shift-register memories, charged coupled devices (CCDs), and magnetic bubble memories (MBMs). DADs are rotational devices made of magnetic materials where any block of information can be accessed directly.

2.3 Secondary Storage Devices

Magnetic devices are widely used for data storage because they offer much greater memory capacity at a lower cost per bit of data stored than semiconductor devices. As the computational speeds increase, the computers are able to utilize and produce growing amounts of data in a given period of time. This, in turn, requires an increase in the capacity of the storage devices from which (or into which) data are drawn (or loaded).

Significant improvements have been made in magnetic storage devices in the past two decades. These include the introduction of the solid-state storage devices (SSD), which are fast random-access devices used to hold pre-staged data or intermediate results which are manipulated repetitively, large disk arrays and mass robotic media. The SSD offer significant potential for performance improvement of more than one order of magnitude on Input/Output-bound applications, and thus allow users to develop new algorithms that would not be practical with traditional disk input/output.

The storage density of magnetic disks has increased from 200,000 bit per square inch in 1967 to its current value of over 20 million bits per square inch. Continuation of this trend is likely to yield storage densities of the order of 300 million bytes per cubic inch within a decade. Optical storage media, such as compact disks, can provide from 5 to 7 times the density of information that magnetic devices can achieve (see Ref. 6).

2.4 User Interface Hardware and Software

Great efforts are now aimed at improving the productivity of the analyst and designer by developing intelligent software and hardware interfaces. More structural analysis and design software are becoming turnkey systems with defaults built in, and with simple menu options. Current user-interface software includes DOS, OS/2, Unix-based systems, and Windows NT. Current menu options are multiwindowed (one window for each task) and are controlled by lightpen, touchscreen, or mouse (which are advanced user-friendly capabilities for accessing the system). The discrete model can be generated by using either one of the geometric modeling software packages or a CAD system.

Multimedia workstations and virtual reality facilities that embrace all forms of human communication and provide elaborate graphics, video, animation and visualization capabilities have been developed. Current *interactive multimedia* systems contain a compact-disc ROM (CD-ROM) which supplies text, graphics, or still images of videocassette quality, plus a voice-over, for the user to browse through interactively choosing different paths and viewpoints. Full-motion color video of television quality with CD audio, plus text and graphics is available in high-level multimedia systems (see Ref. 7). *Virtual reality* provides multisensory experience - through dimensional sight and sound, touch, forced feedback or forced resistance, and motion. Special hardware devices are used which include data gloves, joysticks, helmet-mounted displays, goggles, earphones and body suits to get the necessary sensing feedback to experience the computer world (see Ref. 8). The devices are connected to graphics workstations.

Future multimedia, and virtual reality facilities will provide the user with the freedom to choose from a variety of communication modes (e.g., voice, electronic pad that responds to handwriting, sensors that track the eye movement, and a glove that enables the wearer to manipulate objects on the screen). They will incorporate HD technologies and sonification facilities for mapping of data to a sound domain.

2.5 Distributed Computing and Networking

High-performance engineering systems require strong collaborative analysis and design efforts, involving several engineers and machines. In support of collaborative computing, layers of communication lines and devices are used. These layers include local-area networks (LAN); backbone networks connecting supersystems, mass storage, and general-purpose mainframes; and wide area networks (WAN) connecting geographically remote computers and terminals.

Local-area networks are designed to facilitate the interconnection of a variety of computer-based equipment (including personal computers, workstations, and superservers) within a small area. They have high transmission rates (of the order of 10 Mbits/sec), and allow different workstations to share expensive equipment and facilities. Examples of LAN are provided by Ethernet, Arcnet and token-ring network. Also, fiber distributed data interface (FDDI) and high-performance parallel interface (HiPPI) facilities have been developed, with transmission rates of 100 Mbits/sec, and 800 Mbits/sec to 1 Gbit/sec., respectively.

Backbone networks can provide a communication service between several local-area networks, as well as between different supersystems in a large industrial complex, or a university campus. Their transmission rate is of the order of 50 Mbits/sec. An example of backbone networks is the HYER channel of Network Systems Corporation.

The first remote (or wide-area) network (WAN), the ARPANET (Advanced Research Projects Area Network), was built in 1969. It demonstrated the feasibility and practicality of distributed computing, as well as of communication technology based on packet switching. A number of government-supported and commercial packet networks are now available. Examples of the first are NASNET of NASA, NSFNET T1, of the National Science Foundation. The latter was upgraded to the current NSFNET T3, with a transmission rate of 45 Mb/sec. Commercial networks include TELENET, BITNET and TYMNET. Moreover, the coupling of digital networking with the existing telephone and Digital Private Branch Exchange (PBX) systems into Integrated-Services Digital Networks (ISDNs) provided access to a wide range of data and central computers via desktop workstations (Ref. 9). Current work is directed towards increasing the transmission rates of local-area, backbone and wide-area networks (see Ref. 10). Within the next few years transmission rates of the order of Gbit/sec will be available, through the National Research and Educational Network (NREN) - see Fig. 5, which is one of the major components of the high-performance computing and communications initiative in the U.S. (Refs. 11 and 12).

Future directions include development of cell switching technology for switched, bandwidth on-demand high-speed networks (asynchronous transfer mode - ATM - see Ref. 13), and networking technology to support portable computing and communications. The cellular phone is likely to evolve into a portable voice and data machine that supports mobile communications. ATM has the potential of multiplying the network capacity by thousands and carrying mixed data, voice, text, image and video traffic simultaneously over one network. Because ATM is protocol independent, it can integrate different LANs and WANs.

3. CLASSIFICATIONS AND PERFORMANCE EVALUATION OF NEW COMPUTING SYSTEMS

Because of the rapid progress made in recent years in component technology, a number of novel forms of computer architectures have emerged. Some of the new architectures are commercially available; others are still research tools aimed at achieving high-performance and/or low-cost computations. In this section the classifications and performance evaluation of different machines is discussed, and in the succeeding sections, the major features of the new and emerging high-performance machines (supersystems) and small systems are described.

3.1 Classifications of Computing Systems

In an effort to identify and clarify the differences between the different machines, a number of classifications and taxonomies have been proposed. One of the earliest and most commonly-used classifications is that introduced by Flynn (Ref. 14) which is based on the concurrency in instruction control and concurrency in execution. A stream is defined as a sequence of items (instructions or data) as executed or operated on by a processor.

Four broad classes can be identified according to whether the instruction or data streams are single or multiple (see Fig. 6).

- a. *Single-Instruction-Stream, Single-Data-Stream (SISD) Machines.* These machines include the conventional serial computers which execute instructions sequentially, one at a time.
- b. *Single-Instruction-Stream, Multiple-Data-Stream (SIMD) Machines.* These are vector computers that have a single control unit, a collection of identical

processors (or processing elements), a memory or memories, and an interconnection network which allows processors to exchange data. During execution of a program the control unit fetches and decodes the instructions and then broadcasts control to the processing elements. Each processor performs the same instruction sequences, but uses different data. These operations are usually referred to as lock-step operations.

- c. *Multiple-Instruction-Stream, Single-Data-Stream (MISD) Machines.* In these machines the same data stream flows through a linear array of processors executing different instruction streams. This architecture is also known as *systolic arrays* for pipelined execution of specific algorithms.
- d. *Multiple-Instruction-Stream, Multiple-Data-Stream (MIMD) Machines.* These are parallel computers which contain a number of interconnected processors, each of which is programmable and can execute its own instructions. The instructions for each processor can be the same or different. The processors operate on a shared memory (or memories), generally in an asynchronous manner.

MIMD machines can generally be divided, according to the level of interaction between processors and their physical location, into shared-memory multiprocessors and message-passing multicomputers (see Fig. 6). The major distinction between multiprocessors and multicomputers lies in memory sharing and the mechanisms used for interprocessor communication. In a multiprocessor system, the processors communicate with each other through shared variables in a common memory. In a multicomputer system, each computer node has a local memory, unshared with other nodes. Interprocessor communication is done through message passing among the nodes.

Examples of computing systems which belong to each of the classes are given in Fig. 6. Also, block diagrams of the SISD, SIMD, MISD, and MIMD machines are shown in Fig. 7. The architectural evolution of computing systems from sequential scalar processors to vector processors and parallel computers is shown in Fig. 8. The trend has been to build more hardware and software functions into the system. The skewed tree demonstrates that most of current high-performance computers are designed with look-ahead techniques, functional parallelism, pipelining at various levels, using explicit vectors, and exploiting parallel processors in SIMD or MIMD mode. Note that some of the SISD machines have parallel processing mechanisms (due to the presence of multiple functional units and/or facilities for overlapping computations and I/O); however, the parallel processing is embedded in the hardware below the instruction level, and the appearance of sequential execution of instructions is preserved.

3.2 Performance Evaluation of Computing Systems

- a. *Peak Versus Sustained Performance of Machines.* The performance of sequential computers is usually measured by: (1) the *peak computational speed* measured in millions (or billions) of floating-point operations per second (MFLOPS or GFLOPS); (2) the *peak execution rate* of arithmetic, logic, and program control instructions, measured in millions (or billions) of instructions per second (MIPS or GIPS); and (3) the *peak rate of knowledge processing* in millions (or billions) of logical inferences per second (MLIPS or GLIPS). In the case of SIMD and MIMD machines, the peak computational speeds in terms of millions (or billions) of floating-point operations

per second can be estimated. However, the sustained computational performance in these machines is difficult to estimate since it varies with the level of parallelism achieved, and the overhead incurred in exploiting the parallelism in the particular application (Ref. 5). These, in turn, are functions of the formulation used, the numerical algorithm selected, the computer implementation, the compiler and the operating system used, as well as the architecture of the hardware. For vector multiprocessors the peak performance can be estimated as the sum of the vector performance of all the processors, and the lowest performance is that of a single-scalar processor. A widely used approach for estimating the sustained performance of a machine is benchmarking - running a set of well-known application programs on the machine. A number of general benchmarks have been proposed over the past decade. These include the Livermore Fortran Kernels, NAS Kernels, the Linpack benchmark, the Perfect benchmarks, Whetstone benchmarks and the SLALOM benchmarks. A description of some of these benchmarks is given in Refs. 5 and 15 to 18. At the present, no generally-accepted benchmark strategy is available for assessing the performance of SIMD and MIMD machines. A discussion of the effectiveness and pitfalls of benchmarking is given in Ref. 19, 20 and 21. Figure 9 shows the sustained performance in GFLOPS of a number of computers based on using Linpack for solving 1000 dense equations (see Ref. 18).

A number of speedup models have been proposed in recent years. These include models based on Amdahl's law, Gustafson's scaled speedup and the memory-bounded speedup of Sun and Nai. The first model is described subsequently. The latter two models are described in Ref. 5.

- b. *Amdahl's Law.* In 1967, Amdahl made the observation which has come to be widely known as Amdahl's Law (Ref. 22): If a computer has two modes of operation - one high speed and the other low speed - then the overall performance will be dominated by the low-speed mode. Amdahl's Law is fundamental to the understanding of computer performance. It shows that a bottleneck in a computing system is associated with a small execution rate (low-speed mode of operation) which is out of balance with the rest of the execution rates (high-speed modes of operation). In such a computing system, increasing the execution rates for the high-speed modes of operation may yield only a small increase in performance unless the fraction of computation performed in the low-speed mode is essentially zero. This explains why vector computers with low-scalar speeds have not been successful. A discussion of the application of Amdahl's Law to massively parallel processors is given in Ref. 5 and 23.

One of the major shortcomings in applying Amdahl's law is that the problem cannot scale to match the available computing power as the machine size (e.g., number of processors in a parallel computer) increases. Gustafson (Ref. 17) proposed a fixed-time concept which leads to a scaled speedup model. This concept is based on the assumption that as the machine size (or number of processors) increases, the size of the computational model is increased to increase the accuracy of the numerical simulations.

4. MAJOR FEATURES OF NEW COMPUTING SYSTEMS

New computing systems cover a broad spectrum of machines ranging from the large supersystems to the small portable, embedded computers, and microprocessors. A description of some of these machines is given in Refs. 5 and 24. Herein, a brief discussion is given of the major features of new computing systems that are likely to have the strongest impact on structural analysis and design.

Most of the new and emerging machines achieve high performance through concurrent activities in the computer (or the network of computers). The exploitation of these concurrent events in the computing process is usually referred to as parallel processing. When parallel processing is done on physically dispersed and loosely coupled computer networks, it is usually referred to as distributed processing. The concurrency is used not to speed up the execution of individual jobs, but to increase the global throughput of the whole system.

Parallel processing can be applied at four distinct levels, namely: job level, program level, inter-instruction level, and intra-instruction level (Refs. 25 and 26). The hardware and software means to achieve parallelism in each case are outlined in Table 1. The hardware role increases as the parallel processing goes from high (job) level to low (intra-instruction) level. On the other hand, the role of software implementations increases from low to high levels.

4.1 Supersystems

Supersystems are a class of general-purpose computers designed for extremely high-performance throughput. Although there is no universally accepted definition or classification of supersystems, the following three classes of supersystems can be identified (based on the performance, memory system used, and cost):

- a. large supersystems
- b. near supers
- c. superservers

The current price ranges for the three classes in U. S. dollars are: over \$10M; \$2M to \$5M; and less than \$2M, respectively.

Current and emerging *large supersystems* have the following four major characteristics: a) high computational speeds (maximum speeds of the order of 10 GFLOP or more); b) high execution rates (of the order of 10 GIP or more); c) large main (or central) memory (with a capacity of 1 GByte or more); and d) fast and large secondary memory (or storage devices) with a sophisticated memory management system.

The development of large supersystems now spans four generations. The first generation included the array of processors ILLIAC IV (SIMD machine); and the pipeline (or vector) computers CDC STAR-100, and Texas Instruments Advanced Scientific Computer (ASC). The second generation supersystems included the CRAY-1, which featured the pipelined vector instructions introduced in the first generation machines, but carried out in a clever register-to-register mode. They also included the CDC CYBER 203 (an enhanced successor of STAR-100, sporting a faster scalar unit). Most of the third-generation large supersystems used a hybrid combination of pipeline and array processors to achieve high performance. Examples of these machines are: the CDC CYBER 205, the CRAY X-MP, CRAY-2, CRAY YMP, ETA-10 and the Japanese machines Fujitsu VP-400, Hitachi S810/20 and S820/80; and NEC SX2-400. The top sustained speed of the third-generation supersystems is of the order of 500 MFLOPS with bursts to 1.5 GFLOPS (billions of floating point operations per second).

The current generation of supersystems includes both the vector multiprocessors and the massively parallel computers. Examples of these machines are the CRAY C916 and CRAY-3, Thinking Machines Corporation CM-5 (with 1024 processors expandable to 16,384) and the CRAY massively parallel computer T3D (with up to 2,048 processors), Intel Paragon XP-S, the Japanese NEC SX-3/44R, Hitachi S-3800/480 and Fujitsu VPP 500 computers. It is anticipated that the computational speeds of the large supersystems will continue to increase, and will reach 1 TFLOP (10^{12} floating point operations per second) before the end of the decade. The architectural characteristics of some of the third generation, new and emerging large U.S. and Japanese supersystems are given in Refs. 3, and are summarized in Table 2.

Near supers are high-end mainframes with peak computational speeds in the range of 500 MFLOPS to 1 GFLOP; execution rates of the order of 500 MIPS-1GIP; and less sophisticated memory systems than those of the large supersystems. Examples of these machines are the MasPar MP-2 and Convex C3800.

Superservers are multiprocessor workstations with peak computational speeds in the range of 100 MFLOPS to 1 GFLOP, and execution rates of the order of 100 MIPS, or more. Examples of these machines are Sun SPARCcenter 2000 multiprocessor server, and SGI Challenge.

Supersystems can impact structural analysis and design in a number of ways including:

- a. Increasing the level of sophistication in modeling flight-vehicle structures to new levels which were not possible before. Examples are provided by reliability-based (stochastic) modeling of engineering systems (to account for probabilistic aspects of geometry, boundary conditions, material properties and loading), and multidisciplinary analysis and design of structures.
- b. Reducing the dependence on extensive and expensive testing. This is particularly important for future large space systems (e.g., large antennas, large solar arrays, and the space station) where the reliability of testing in 1-G environment can be, at best, questionable; and,
- c. Enhancing the physical understanding of some aspects of the response of engineering systems which are difficult, if not impossible, to obtain by alternate approaches. An example of this is the study of the implications of various microstructural mechanisms of damages on the macroscopic response of the structure.

4.2 Parallel Processing Machines

In the last few years there has been an explosion in the number of parallel processing machines developed. The architectural characteristics of some of these machines are given in Table 3. Some of these machines belong to the class of supersystems discussed in the preceding subsection. In an effort to identify and clarify the differences between these machines, a number of classifications and taxonomies have been proposed, including Flynn's classification described in the preceding subsection. However, Flynn's classification does not adequately describe several of the new multiprocessor machine architectures. More descriptive classifications of multiprocessor systems are based on the following characteristics (see Ref. 23): processor granularity and type; memory organization, connection topology between processors and memory systems; reconfigurability (to meet the performance needs in more than one environment);

control mode (control flow versus data flow); scalability (e.g., possibility of achieving a proportional increase in performance with increasing system resources); and homogeneity or nonhomogeneity of the processors (for example, the CRAY C916 has homogeneous processors, but a combination of a serial computer and an attached processor can be viewed as a heterogeneous multiprocessor). Herein, an extension of Flynn's taxonomy, proposed in Ref. 27, is described. Also, the classifications based on the first three characteristics, namely, processor granularity and speed; memory organization; and connection topology, are discussed (see Ref. 26).

4.2.1 Extension of Flynn's Taxonomy

The extended taxonomy uses levels of concurrency as one principle, and instruction types as another. Four generic types of instructions and three levels of control concurrency are included in the taxonomy. The four generic types of instruction are: scalar, vector, systolic and very-long instruction word (VLIW). They are distinguished by the number of operations and number of pairs of operands as shown in Table 4.

The three levels of control concurrency include the serial and parallel types (with single and multiple instruction streams), as well as the clustered type (with several independent sets of multiple instruction streams). The three levels constitute a hierarchy, with parallel control being a generalization of serial control, and clustered control being a generalization of parallel control.

The extended taxonomy has twelve types of computer architecture. Examples of some of these types are given in Table 5.

4.2.2 Processor Granularity and Speed

Multiprocessor systems can be divided into three groups:

- a. *Coarse-grain machines* consisting of a small number of very powerful processors or central processing units (CPUs) linked together. Examples of these machines are CRAY C916, CRAY 3, IBM ES/9000-711 VF, IBM 9076 SP1 Scalable Power Parallel System (with 8 to 64 processors).
- b. *Fine-grain machines*. These are massively parallel machines which combine thousands of relatively weak processors. When the processors work in concert they can form very powerful computers. Examples of machines with synchronous processors are the MasPar MP-2, with up to 16,384 processors; the Connection Machine CM-5 of Thinking Machine, Inc. with up to 16,384 processors; nCUBE 2 (with up to 8,192 processors); and Kendall Square KSR1 (with up to 1,088 nodes).
- c. *Medium-grain machines*. These fall somewhere between the first two categories. They have a moderate number (e.g., tens or hundreds) of low-cost and mid-range processors. Examples are Alliant CAMPUS/800, BBN Butterfly TC 2000, Encore Multimax and Sequent Balance 8000.

4.2.3 Memory Organization

One of the most important classifications of multiprocessor systems is that based on memory organization. According to this classification there are shared-memory machines, private (or semiprivate) memory machines, and multilevel-memory machines.

Shared (or global) memory. This is a single monolithic main memory accessible to all processors. Examples are provided by the memories of the CRAY C916.

Distributed memory. This is a private memory connected to a single processor and requiring communication to transfer information. Examples are provided by the memories of the Connection Machine, the FPS T-Series, and the Intel iPSC.

Multilevel (hierarchical) memory is available in computer systems such as the ETA-10 and the Myrias 4000.

4.2.4 Connection Topology

Multiprocessor systems with private (or semiprivate) memories can be distinguished by the interconnection pattern (or topology) between processors, memory systems and I/O facilities. The topology affects the class of problems which can be efficiently solved on the machine. The commonly-used connection topologies are:

Bus (or ring) type connection. The various processors, memory systems, and I/O facilities reside on a common communication bus or set of buses. Most computers of this type incorporate global (or central) memory, shared by all processors, and accessed via the communication bus. Examples of machines with bus connection are the Encore Multimax, FLEX/32, and Elxsi 6400 computers.

Hypercube or n-cube connection. Each processor is directly connected to a number of its neighbors, n . The number of connections per processor results in a multidimensional cube with 2-in. nodes. This type of connection is usually used with distributed memory machines. Examples of machines with hypercube connection are the Intel iPSC and the FPS T-Series.

Switching connection. This mechanism is based on placing a switch between the processors and memory banks, thereby removing the ownership property between processors and memory. For different settings of the switch, a given processor will be connected to different memory banks.

Although most of the currently available machines for performing parallel computations belong to either SIMD or MIMD categories of Flynn's classification, there are a number of variations. Some of these variations are described in Refs. 5 and 28 to 32, along with surveys of the current and emerging parallel systems. Two of these concepts, which exploit parallelism in ways which have promise for achieving high performance, are data-flow machines and systolic array architectures (MISD machines). The two concepts are described subsequently.

The *data flow* concept is based on a data-driven mechanism which allows the execution of any instruction to be driven by data (i.e., operand) availability. By contrast, conventional computers are based on a control flow mechanism by which the order of program execution is explicitly stated in the user program. Data flow computers emphasize a high degree of parallelism at the finite-grain instructional level, based on the dependency graph of a computation. The algorithm for a given computation is first written in a special programming language designed for data-flow applications (e.g., the language Id developed at the Massachusetts Institute of Technology). A compiler then translates the program into a data-flow graph (which corresponds to the machine language for data flow architecture). A number of experimental dataflow computers have been built. An example of these machines is the tagged-token data flow computer built by Arvind and his associates at MIT.

Systolic architectures follow from space and time representations of certain numerical algorithms which map directly onto geometrically regular VLSI/WSI (Very Large-

Scale Integration/Wafer-Scale Integration) structures. The term systolic array comes from the notion of data pulsing through the processors in the network in an analogous manner to that of blood pulsing through the circulatory system in the body (see Ref. 33). In its purest form a systolic system consists of a regular array of processing elements all doing the same calculation and passing results onto their nearest neighbors every cycle. In this way the array as a whole computes some recurrence function. The prime features which make this style attractive are the short interconnections, the regularity which gives a high packing density and simplifies the design, and the high degree of parallelism which, when combined with the other features, leads to high performance circuits. Potential applications of systolic arrays in finite element applications are discussed in Refs. 34, 35 and 36. More advanced concepts of systolic arrays and systolic computing are described in Ref. 37.

Parallel processing systems can substantially expedite the multidisciplinary design process of structures by allowing the designer to carry out various analysis and design tasks in parallel. The tasks can belong to an individual discipline as well as to other disciplines (such as in multidisciplinary optimization problems).

4.3 Microprocessors and Small Systems

A broad spectrum of low-cost small systems exist now, including new powerful microprocessors, transputers, embedded computers, palmtop (handheld) computers, notebook and subnotebook computers, laptop computers, desktop computers, and engineering workstations. Several classifications have been attempted in the past for some of these systems based on word length (8-bit, 16-bit, 32-bit and 64-bit machines), weight, cost, amount of directly addressable memory, and computing speed (e.g., 8, 16, 20, 25, 66, 100-300 MHz - see, for example, Ref. 38). However, the dramatic increase in hardware capabilities of small systems, coupled with the rapid reduction in cost, are blurring the boundaries between these systems, and making some of the classifications of questionable value (Ref. 39). Partial lists of portable, laptop computers, engineering workstations, and some of their characteristics are given in Refs. 40 and 41. Herein the development of microprocessors, transputers, and engineering workstations are discussed.

4.3.1 Microprocessors and Chip Technology

The trend of ever-increasing the number of devices packaged on a chip has resulted in the miniaturization and increase in speed of microprocessors. The new powerful chips can be used as monitoring systems (e.g., embedded computers) for the detection, recording and evaluation of stochastic damage, thereby increasing the mean time between inspection for structural components.

In the 1970s the efforts directed towards creating machines with very fast clock cycle, that can execute instructions at the rate of one per cycle (like microprogrammed controllers), resulted in the development of Reduced Instruction-Set Computing (RISC) processors. These are microprocessors that provide high-speed execution of simple instructions. The implementation of RISC architecture began at IBM in the mid 1970s. RISC architecture was applied to special-purpose processors as well as to general-purpose computers. The basic notion of RISC has now evolved to encompass chips in which the chip areas formerly used for decoding and executing complex instructions, are used for caching instructions. RISC chips offer the following advantages over the Complex Instruction-Set Computing (CISC) chips: much smaller size chips, more throughput, shorter design time,

better support for high-level languages, and the ability to emulate other instruction sets.

In the last decade a new type of powerful VLSI chip (superchip) which packs RISC and a limited amount of RAM has been developed. The superchip is called a transputer, and is manufactured by Inmos, Ltd. of Bristol, England. The transputer was designed from the outset for parallel and distributed processing. The transputer has hardware support for parallel tasks, including local (on-chip) memory, and four high-speed communication links. These can transfer data at the rate of 20 Mb (Megabits) per second, thereby enabling the transputer to be interconnected in powerful arrays. A high-level programming language, Occam, has been especially developed for parallel processing on the transputer. Also, other languages (e.g., Ada Fortran, Pascal, C and C++) are available for use on the transputer.

A range of transputer boards and modules now exist which can be plugged into conventional and desktop computers to speed up the computations. Also, a desktop supercomputer with many transputers has been developed by Meiko, a company in Bristol, England, that grew out of Inmos. Transputer networks, formed by linking together transputers in arrays, pipelines, rings and other patterns, have been efficiently used in a wide variety of applications including solution of finite element equations and graphics processing. To date the latest transputer, the T9000 is a 32-bit processor, with a 64-bit floating-point unit and 16 Kbytes of Cache memory. It can be connected to external memory of up to 4 Gbytes. It has 4 user data links and 2 control links, each with a transmission rate of 100 Mbits per sec. per direction per link. The clock cycle is 20ns, peak execution rate is 200 MIPS and peak computational speed is 25 MFLOPS. Current RISC processors, such as the Intel i860, SPARC, MIPS R3000, IBM RS/6000 have clock rates ranging from 20 to 120 MHz.

A special class of RISC processors are the *superscalar processors*, which allow multiple instructions to be issued simultaneously during each cycle. Thus the effective cycles per instruction of a superscalar processor should be lower than that of a generic scalar RISC processor.

The very long instruction word (VLIW) architecture uses even more functional units than that of a superscalar processor. The cycles per instruction of a VLIW processor can be further lowered.

Recently, a number of powerful 64-bit RISC chips and processors have been developed. These include the DEC 21064 (ALPHA) - see Fig. 10, the PA-RISC 7100, the Intel Pentium and the SGI/MIPS TFP chips. A summary of the characteristics of these chips is given in Table 6. The powerful, RISC-based microprocessors are used in both the high-performance workstations, and in the massively parallel computers introduced in the 1990s (see Fig. 11).

4.3.2 Small Systems

Significant advances have been made in portable computers and peripherals (e.g., packet modems and portable printers), as well as in wireless communication for mobile computing. Examples of the small systems recently developed are the personal digital assistants (PDAs Palmtop (handheld) computer; subnotebook computers weighing 4.5 to 9 lbs. and having 20 to 32 Mbytes of RAM, and 120 to 210 Mbytes of hard disk.

4.3.3 Engineering Workstations and Superservers with Advanced Visualization Capabilities

Single-user engineering workstations and superservers using VLSI 32- and 64-bit processor chips, and having

internal graphics facilities, and over 1 Gbyte of addressable memory have been developed. Both single processor and multiprocessor systems are available. Examples of single-processor systems are the HP Apollo 9000 series 700, the DEC 3000 model 500X AXP, and the IBM RS6000 systems. Examples of the multiprocessor superservers are Sun SPARCcenter 2000 (2-20 processors) and SGI Challenge Systems (2-18 processors, peak computational rate of 5.4 GFLOPS). The upper end of the advanced workstations are usually referred to as superservers and were discussed in the preceding section.

5. ADVANCES IN PROGRAMMING ENVIRONMENT AND SOFTWARE TECHNOLOGY

Although considerable effort is now devoted to increasing the productivity of the analyst and designer through the development of powerful programming environment, software and programming languages remain the primary pacing items for exploiting the potential of new computing systems.

5.1 Programming Environment

This refers to the array of physical and logical means by which the analyst transmits instructions to the machine. It includes the user-interface devices; interactive programming tools (e.g., debuggers, editors, file-maintenance utilities), and tools for automatic (and semiautomatic) mapping of numerical algorithms on different machines.

The programming environments on most of the existing new computing systems are limited to a standard sequential language compiler, and extensions to support concurrency (viz. vectorization and parallelization). The extensions of currently used programming languages to support concurrency (Fortran, C, Lisp) are not the same on different machines. A description of some of the work on development of software environment is given in Refs. 42 to 45.

Current and future interface devices have been discussed in a previous section. Future powerful programming languages should enable the user to state the mathematical and logical formulation of the problem in the expectation that the language can fill in the details. These languages should be architecture-independent high-level languages to allow the portability of the programs. Extensive work is currently being done to develop a machine-independent programming interface for parallel machines that can achieve an efficiency comparable to programs hand coded in languages that reflect the specific underlying architectures.

5.2 AI Knowledge-Based and Expert Systems

AI-based expert systems, incorporating the experience and expertise of practitioners, have high potential for the modeling, analysis and design of structures. These systems can aid the analyst in the initial selection and adaptive refinement of the model, as well as in the selection of the appropriate algorithm used in the analysis. Expert systems can also aid the designer by freeing him from such routine tasks as the development of process and material specifications. The potentials of AI and expert systems in computational mechanics is described in Ref. 46, and a review of the capabilities of some of the currently available expert systems and their limitations are given in Refs. 47 and 48. A description of a knowledge-based system used as a modeling aid for aircraft structures is given in Ref. 49. The requirements, design and implementation of an intelligent interface to a computational fluid dynamics flow solver is discussed in Ref. 50.

5.3 Large Powerful Data Management Systems and Databases

Future engineering software systems are likely to have the basic analysis software (such as data management, control, etc.) as part of the software infrastructure and the discipline specifics (such as the finite element properties of the structure) as part of application software. Conventional database management systems (DBMs) developed in the last decade, such as relational database management system (RIM), provided multidisciplinary coordination, and helped in the integration of structural analysis programs into CAD/CAM systems. However, these conventional DBMs do not meet the data requirements for the current and emerging engineering/design environment (see Ref. 51). Among the different advanced data/process modeling methodologies which have high potential for multidisciplinary analysis and design applications are: the three-level IDEF methodology developed by the Air Force's integrated computer-aided manufacturing program (see Ref. 52); Nijssen's information analysis method based on a binary relationship model; Entity relationship model; and object-oriented data model. A description of these models is given in Ref. 51.

6. ADVANCES IN NUMERICAL ALGORITHMS AND COMPUTATIONAL STRATEGIES

To achieve high performance from any computing system, it is necessary either to tailor the computational strategy and numerical algorithms to suit the architecture of the computer, or to select the architecture which may effectively map the computational strategy and execute the numerical algorithm. Extensive work has been devoted to the development of vectorized and parallel numerical algorithms for new computing systems. Review of some of this work is contained in a number of monographs, survey papers and conference proceedings. (See, for example, Refs. 53 to 57).

In this section a brief review is given on the recent progress made in special parallel numerical algorithms and computational strategies that are influencing structures calculations.

6.1 Parallel Numerical Algorithms

In parallel algorithms, independent computations are performed in parallel (i.e., executed concurrently). To achieve this parallelism, the algorithm is divided into a collection of independent tasks (or task modules) which can be executed in parallel and which communicate with each other during the execution of the algorithms. Parallel algorithms can be characterized by the following three factors:

- a. Maximum amount of computation performed by a typical task module before communication with other modules.
- b. Intermodule communication topology, which is the geometric layout of the network of task modules.
- c. Executive control to schedule, enforce the interactions among the different task modules and ensure the correctness of the parallel algorithm.

The three aforementioned factors have been used in Ref. 58 as a basis for classifying parallel algorithms on the conceptual level, and for relating each parallel algorithm to the parallel (or pipeline) architecture to which it naturally corresponds.

The design of a parallel algorithm must deal with a host of complex problems, including data manipulation, storage allocation, memory interference, and in the case of parallel processors, interprocessor communication. In general, the parallel numerical algorithms reported in the literature fall

into two categories: reformulation (or restructuring) of serial algorithms into concurrent algorithms, and algorithms developed especially for parallel machines.

Most of the work on parallel numerical algorithms belongs to the first category, i.e., decomposition of familiar serial algorithms into concurrent tasks. Examples are matrix operations, direct and iterative methods for solution of algebraic equations, and eigenvalue extraction techniques (see, for example, Refs. 53, 55 and 57).

The second category includes the algorithms whose development was spurred by performance criteria for parallel processing. These algorithms have been referred to as uniquely parallel and only a few of them have been reported in the literature (see Ref. 59). Examples of uniquely parallel algorithms are provided by the parallel superconvergent multigrid method (Ref. 60) and the fully parallel algorithm for symmetric eigenvalue problem (Ref. 61). In some cases the performance of uniquely parallel algorithms is superior to their serial counterparts.

6.2 Construction of Parallel Algorithms

The development of parallel numerical algorithms generally follows one or both of two related approaches: reordering, and divide and conquer. Reordering refers to restructuring the computational domain and/or the sequence of operations in order to allow concurrent computations. For example, the order in which the nodes of a finite element grid are processed, and the assembly strategy (node-by-node or element-by-element assembly) may change the degree of parallelism that can be achieved in the solution of the resulting algebraic equations (Ref. 62 and 63). The performance of the node-by-node generation and assembly strategy on a 512 processor Intel Delta and a CRAY C916 computer is shown in Fig. 14 for a Langley Mach 2.4 High-speed Civil Transport (HSCT) model (Ref. 63).

The divide and conquer approach involves breaking a task up into smaller subtasks that can be treated independently. The degree of independence of these tasks is a measure of the effectiveness of the numerical algorithm, since it determines the amount and frequency of communication and synchronization. This idea pervades many of the parallel algorithms and can be extended to the overall computational strategy as described in the succeeding section.

6.3 Comments on Parallel Algorithms and Their Implementation

The following comments concerning parallel algorithms and their implementation are in order:

- a. Effective parallel algorithms are not necessarily effective on sequential computers. In fact, some parallel algorithms involve additional (redundant) floating point operations which make them inefficient on sequential machines. Also, restructured serial algorithms may not be the most efficient on parallel processing machines.
- b. The mathematical properties of the serial and parallel implementations of the same algorithm can be different. For example, the rate of convergence and numerical stability of serial and parallel iterative techniques can be different. In some cases parallel implementation can degrade the performance and in other cases, it improves it (Ref. 59).
- c. To achieve high performance both the numerical algorithm and its implementation must be carefully tailored to the particular machine being used. This raises the question of portability of parallel programs. It is not practical to develop algorithms

and programs for each new computer. Also, it is not desirable to achieve portability at the expense of performance. A number of studies have been devoted to achieving high performance and portability of numerical algorithms on advanced computers. Two approaches have been proposed in Refs. 64 and 65: 1) restructuring of algorithms in terms of high-level modules (e.g., matrix-matrix and matrix-vector operations); and 2) developing and implementing an abstraction of parallel processing that is independent of the architecture.

- d. On most of the currently-available multiprocessing systems vectorization offers greater performance improvement over multitasking (i.e., parallelization). Consequently, if multitasking conflicts with efficient vectorization (e.g., multitasking results in short vector lengths), then the algorithm should be vectorized rather than parallelized.

6.4 Performance of Parallel Numerical Algorithms

Computational complexity (e.g., number of floating-point arithmetic operations) has long been used as a measure of the performance of serial algorithms. However, it is not appropriate measure for parallel numerical algorithms. This is because parallel computers can support extra computation at no extra cost if the computation can be organized properly; and parallel computers are subject to new overhead costs (e.g., synchronization and communication) that are not reflected by computational complexity.

One of the most commonly-used measures for the performance of parallel numerical algorithms is the speedup, S , which is defined as follows:

$$S = \frac{\text{execution time using one processor}}{\text{execution time using } p \text{ processors}}$$

The measure S has the advantage that it uses the execution time and, therefore, incorporates the synchronization and communication overhead. However, it has the drawback of comparing the execution time of the same algorithm on the single and multiple processors.

Another definition of speedup, based on Amdahl's Law, was proposed by Ware (Ref. 66), and is expressed by the following simple formula:

$$S(p, f) = \frac{1}{1 - f \left(1 - \frac{1}{p}\right)} \quad (1)$$

where S is the maximum speedup achievable by using p processors; and f is the fraction of computational work done in parallel (at the high execution rate).

In Eq. (1) the execution time using a single processor has been normalized to unity. The range of change of S with f , at $f = 1$, is quadratic in p , i.e.,

$$\left. \frac{dS}{df} \right|_{f=1} = p^2 - p \quad (2)$$

Therefore, for massively parallel processors the fraction on parallelism must grow with the number of processors in order to achieve reasonable speedups.

The utilization rate of the multiprocessor system, U , is defined as follows:

$$U(p, f) = \frac{S}{p} \quad (3)$$

A utilization rate of 1 means that every processor is busy computing all the time.

Figure 12 shows the theoretical speedup and the utilization rate of multiprocessor systems as a function of the fraction of parallelism, f , and the number of processors, p . The figure illustrates a key issue in multiprocessor machines: as the number of processors increases, then for a given fraction of parallelism, the degree of utilization decreases.

The following comments can be made regarding Amdahl's Law and Ware's model:

- a. Ware's model assumes that the parallel processing machine is a two-state machine in the sense that at any instant of time either all the processors are operating or only one of them is operating.
- b. Amdahl's Law can be extended to computers with more than two modes of operation with one mode having a lower rate of execution than others. For example, if the scalar mode is taken as the low rate and a balanced higher rate, representative of vector, memory and I/O is taken as the high rate, then Eq. (1) can be used to give the maximum speedup achievable by the system (Ref. 27).
- c. Ware's model does not account for the overhead associated with interprocessor communication, synchronization (for controlling data access and for program control), among others. This overhead may increase with increasing the number of processors, resulting in a speed-down behavior (Refs. 59 and 67).
- d. Eq. (1) measures the speedup relative to the implementation on a single processor of the same algorithm. It does not necessarily measure the efficiency gain due to parallelization. This will be discussed further in the succeeding sections.
- e. In Ware's model the implicit assumption is made that f is independent of p , which is only true if the problem size is fixed. However, in practice the size of the problem increases with the increase in the number of available processors. The parallel part of the program scales with the problem size, but the times for the program loading, I/O, and serial computations do not usually scale with problem size. A discussion of the effect of problem size on the performance of parallel algorithms is discussed in Refs. 68 and 69.
- f. Ware's model can be used for estimating the speedup due to vectorization on vector machines, if f is interpreted as the fraction of vectorizable work, i.e., the maximum speedup due to vectorization is given by:

$$S_v = \frac{1}{1 - f_v \left(1 - \frac{1}{R_v}\right)} \quad (4)$$

where f_v is the fraction of vectorizable work, and R_v is the ratio of the vector to the scalar execution rate. Note that Eq. (4) does not account for the effect of overlapping scalar and vector operations (which can be done on some vector processors).

- g. The maximum speedup due to the combined effects of parallel execution and vectorization (i.e., parallel vectorization) can be represented by the product of $S(p,f)$ [Eq. (1)], and S_v [Eq. (4)]. The speedup is depicted in Fig. 13 as a function of the fractions of vectorizable and concurrent work, f_v and f_p , for a vector multiprocessor machine with four processors and an R_v of ten (vector execution rate ten times that of the scalar execution rate). Note that when $f_v = f_p = 0.9$ the speedup is only 16.19 (less than 41% of the theoretical maximum speedup).

6.5 Special Computational Strategies

In recent years several attempts have been made to exploit the potential of parallel processing machines in the solution of various structural analysis and design problems. These include finite element computations on SIMD vector computers, shared-memory multiprocessors, and message-passing multicomputers (see, for example, Refs. 70 and 71). Table 7 lists the different phases involved in the steady-state finite element analysis, and their suitability for vectorization and parallelization. For time-dependent (transient) problems, several parallel temporal integration techniques have been proposed for structural dynamics problems (see, for example, Refs. 72, 73 and 74). Explicit schemes are well-suited to both vector and parallel processing. This is especially true when a lumped mass matrix is used. The organization of nodal and element data to achieve high performance on the CRAY X-MP is described in Ref. 75. Implicit and semi-implicit schemes require solution of equations at each time step.

A number of special strategies can be used to increase the degree of parallelism and/or vectorization in finite element computations. These strategies are applications of the principle of divide and conquer, based on breaking a large (and/or complex) problem into a number of smaller (and/or simpler) subproblems which may be solved independently on distinct processors. The degree of independence of the subproblems is a measure of the effectiveness of the algorithm since it determines the amount of frequency of communication and synchronization.

Herein, three strategies are discussed: domain decomposition and substructuring; operator splitting; and element-by-element strategies.

6.5.1 Domain Decomposition and Substructuring

The basic idea of domain (or spatial) decomposition is to divide the domain into a number of (possibly overlapping) regions. The initial/boundary-value problem is decomposed into one that involves solution of initial/boundary-value problems on subdomains, thereby introducing spatial parallelism. Since the solution is not available at the interfaces between regions, it is modified iteratively as part of the solution procedure. A review of parallel domain decomposition techniques is given in Ref. 76.

Substructuring techniques are closely related to domain decomposition. They can also be identified at the algebraic level by partitioning the associated matrices in an appropriate way to separate the degrees of freedom that are to be eliminated (the internal degrees of freedom in different substructures) from those to be retained (interface degrees of freedom). Substructuring techniques lend themselves directly to parallel vectorization (Refs. 62 and 77). However, the partitioning of a discretized structure into substructures to achieve well-balanced workload distribution among the different processors is a difficult combinatorial problem. A simulated annealing algorithm for the approximate solution of this problem is presented in Ref. 78. The algorithm is analogous to a method used in statistical mechanics for simulating the annealing process in solids. Other partitioning strategies are described in Refs. 79 and 80.

6.5.2 Operator Splitting

The notion of splitting has long been used to synthesize the solution of a complicated problem from that of a simpler problem (or a sequence of simpler problems). Among the different applications of splitting are the breaking of a multidimensional problem into a sequence of one-dimensional problems, and the development of

iterative (and semi-iterative) techniques for solution of algebraic equations. Splitting can be used as a means of partitioning the computational task into a number of subtasks that are either independent, or only loosely coupled, so that the computations can be made on distinct processors with little communication and sharing.

6.5.3 Element-by-Element Solution Strategies

The modular element-by-element logic inherent in the finite element analysis procedure has been used to develop solution strategies which do not require the explicit generation of the global stiffness matrix. The frontal elimination method was originally proposed by Irons (Ref. 81) to bypass the assembly process. In recent years element-by-element strategies have been developed for the solution of static and dynamic problems as well as adaptive grid generation. A review of these strategies is given in Ref. 82. Element-by-element strategies are well-suited to vector and parallel processing and, therefore, should be seriously considered for use in parallel processing machines.

7. IMPACT OF NEW AND EMERGING COMPUTER TECHNOLOGY ON STRUCTURES TECHNOLOGY

A partial list of some of the advances in computer technology, along with their impact on the structures technology, is given in Table 8. The opportunities offered by the new and projected hardware environment for structural analysis and design are enormous. The current and evolving large supersystems will open the way to a vast range of new applications, and to higher levels of sophistication in modeling flight-vehicle structures. The small, emerging low-cost systems will provide a high degree of interactivity and free the analysts and designers from the constraints that are often imposed on them by large centralized computation centers. The embedded computers will aid in the control of the devices in which they reside. Intelligent interfaces allowing multiple media interaction for both input and output will facilitate the user-machine communication. Flexible high-capacity networks will allow collaborative computing by linking designers and manufacturing teams at different locations.

The AI knowledge-based expert systems and neural networks will aid the initial selection and adaptive refinement of the model, as well as in the selection of the computational strategy and in postprocessing. The large data management systems will facilitate the integration of analysis programs into CAD/CAE and integrated product and process development systems.

8. A LOOK AT THE FUTURE

The driving forces for future developments in computational technology will continue to be: 1) the need for improved productivity and cost-effective engineering systems; and 2) support of innovative high-tech industries (aerospace related, transportation, microelectronics, and nuclear energy).

8.1 Future Flight Vehicles

In the aerospace field, planned future vehicles include high-speed civil transport, earth observation systems, space station, improved orbital delivery systems (which combine low cost and high reliability), structures subjected to very high accelerations, and very high precision shaped and controlled space structures under dynamic and thermal disturbances. The realization of cost-effective future aerospace systems requires: a) technology advances in the materials and structures areas (e.g., development of engineered/smart materials and adaptive structures concepts); b) an integrated product and process

development facility which incorporates both multidisciplinary analysis and design and virtual manufacturing facilities. The multidisciplinary analysis and design facility accounts for the strong couplings between traditionally separate fields (e.g., structures, control, propulsion, aerodynamics, electromagnetics, acoustics and optics). The virtual manufacturing facility includes large CAD/CAM simulation capability, object databases, and virtual reality visualization.

8.2 Computing Paradigm

The current trend towards merging telecommunications and computer technologies will likely lead to the new paradigm of distributed heterogeneous supercomputing (DHS). DHS refers to an integrated computing environment in which the network is the computer. Use of DHS could significantly affect CST by greatly alleviating the size limitations that current memory capacities impose on numerical simulations. Moreover, DHS can achieve sustained speeds in the teraflop (trillion floating-point operations per second) range.

DHS hardware consists of three basic components: a processing component; a data storage and data management component; and a user-interface component. The *processing component* includes a plethora of architectures of the following types: large-grain vector supercomputers (such as CRAY C916); massively parallel systems (such as Intel Paragon, IBM 9076 SP1 scalable power parallel system, CM-5, and CRAY T3D); application-specific special-purpose computers; powerful reconfigurable transputer networks; advanced multimedia workstations/superservers (such as SGI power challenge series and Sun microsystems SPARCcenter 2000); and artificial neural networks. Both shared memory and distributed memory systems can be included in the processing component.

The *data storage/data management* component provides physical storage in the terabyte (10^{12} bytes) range and has large disk arrays, mass robotic media, and a massive high-speed, high-bandwidth file transfer network.

The *user-interface component* includes advanced visualization engines such as virtual reality facilities and high-definition technologies; sonification facilities to map data to a sound domain; and hardware and software interfaces that allow multiple-media interaction, including vision- and speech-recognition facilities. The interfaces will also allow interactive steering and dynamic control of the computations.

DHS's effectiveness depends strongly on two factors: the availability of high-speed local, backbone, and wide-area networks for data transfer between the different computers; and software enabling application programs to be partitioned into tasks that can be executed separately, often simultaneously, on different types of computing platforms. Each task is executed on the architecture for which it is best suited. For the partitioning task, an intelligent (smart) operating system and object-oriented tools are needed to optimize the system's throughput performance.

DHS development is being vigorously pursued by a number of teams at National Science Foundation supercomputer centers (in Illinois, Pittsburgh, and San Diego); at the Naval Ocean Systems Center; at Oak Ridge National Laboratory and at convex and MP computer systems. A proposed National Metacenter Concept that would connect the NSF supercomputing centers is being explored (see Ref. 1 and Fig. 15).

DHS could potentially allow solutions to previously intractable structures problems. It is also likely to change the nature to CST research and design activities by enabling collaboration among geographically dispersed researchers and designers. Future DHS hardware will provide multi-terminal display capability for simulation and will feature other multi-terminal visualization capabilities as well.

8.3 Human/Machine Interfaces

The realization of the potential of new and emerging computing technology in structural analysis and design requires new approaches for human/machine interfaces. The full power of creative artificial intelligence research should be brought to bear on the development of human/machine interfaces which effectively link to as many of the human sensing and communication mechanisms. These mechanisms can initially include coordinated use of visualization, sound and touch; and in the longer term, direct and indirect measures of human encephalographic or other properties of thought and situation awareness.

8.4 Near-Term Needs in the Computational Structures Area

Among the near-term primary pacing items in the computational structures area are: a) understanding of physical phenomena associated with damage and failure of structures, particularly those made of new materials; b) effective coupling of numerical simulations and experiments and the selection of benchmarks for validating and assessing the efficiency of the numerical simulations; c) effective model generation and visualization steering facilities; and d) intelligent/smart computational models (with hierarchical/adaptive modeling facilities).

9. SUMMARY AND CONCLUDING REMARKS

A review is given of the recent advances in computer technology that are likely to impact structural analysis and design of flight vehicles. The characteristics of new and projected computing systems are summarized. Advances in programming environments, numerical algorithms, and computational strategies for new computing systems are reviewed. At one end of the spectrum there are the top-of-the-range large supersystems such as the multiprocessor machines CRAY C916, Fujitsu VPP-500, and the Massively parallel machines CM-5 and nCUBE 3. The performance of large supersystems will continue to improve and their peak computational speeds are likely to reach a teraflop (1×10^{12} floating point operations per second) before the end of the decade. These supersystems will make possible new levels of sophistication in modeling of flight vehicles as well as in problem depth and scope which were not possible before. At the other end of the spectrum the ultrafast microprocessors and the embedded computers will be used in structural health-monitoring systems (for detection and recording of damage), will aid in the control of the devices they reside in, and help in the realization of intelligent (smart or adaptive) structural components. The emerging multimedia workstations with multiple media interaction for both input and output (e.g., graphics and natural languages) will facilitate the user-machine communication, allow adaptive modeling and solution strategies and increase the productivity of structural analysts/designers. The future computing paradigm will be based on distributed heterogeneous supercomputing and will allow collaborative computing by linking design and manufacturing teams at geographically different locations.

The discussion of the new computing systems presented herein is intended to give structural analysts and designers some insight into the potential of these systems for providing cost-effective solutions of complex structural

problems, and to stimulate research and development of the necessary algorithms, firmware and software to realize this potential.

ACKNOWLEDGEMENT

The work of the first author is supported by a NASA Cooperative Agreement NCCW-0011.

REFERENCES

1. Kaufman, W.J., III and Smarr, L.L., "Supercomputing and the Transformation of Science", Scientific American Library, New York, 1993.
2. Noor, A.K., "New Computing Systems and Their Impact on Computational Mechanics", State-of-the-Art Surveys on Computational Mechanics, (A.K. Noor and J.T. Oden, eds.) The American Society of Mechanical Engineers, New York, 1989, Chapter 16, pp. 515-556.
3. Cole, B.C., "Here Comes the Billion-Transistor IC", Electronics, 60, 7, 1987, pp. 81-85.
4. Johnson, W., Teng, R. and Balde, J. (eds.), "Multichip Modules: Systems Advantages, Major Constructions and Materials Technology", IEEE, New York, 1993.
5. Hwang, K., "Advanced Computer Architecture: Parallelism, Scalability, Programmability", McGraw Hill, Inc., New York, 1993.
6. Kryder, M.H., "Data-Storage Technologies for Advanced Computing", Scientific American, 257, 4, 1987, pp. 117-125.
7. Interactive Multimedia - Special Report, IEEE Spectrum, March 1993, pp. 22-39.
8. Ellis, S.R., "Nature and Origins of Virtual Environments: A Bibliographical Essay", Computing Systems in Engineering, 2, 4, 1991, pp. 321-347.
9. Stallings, W. (ed.), "Advances in Integrated Services Digital Networks (ISDN) and Broadband ISDN", IEEE Computer Society Press, New York, 1992.
10. Kahn, R.E., "Networks for Advanced Computing", Scientific American, 257, 4, 1987, pp. 136-143.
11. Advanced Network Technology - Background Paper, OTA-BP-TCT-101, Office of Technology Assessment, U.S. Congress, U.S. Government Printing Office, Washington D.C., June 1993.
12. "Grand Challenges 1993: High Performance Computing and Communications", A Report by the Committee on Physical, Mathematical and Engineering Sciences, Office of Science and Technology Policy, Washington, D.C., 1993.
13. Joel, A.E., Jr. (ed.), "Asynchronous Transfer Mode Switching", IEEE, New York, 1993.
14. Flynn, M.J., "Some Computer Organizations and Their Effectiveness", IEEE Transactions on Computers C-21, 1972, pp. 948-960.
15. Berry, M. et al., "The Perfect Club Benchmarks: Effective Performance Evaluation of supercomputers", Int. Journal of Supercomputing Applications, 3, 3, 1989, pp. 5-40.
16. Bailey, D., Barton, J., Lasinski, T. and Simon, H. (eds.), "The NAS Parallel Benchmarks", Technical Report RNR-91-02, NASA Ames Research Center, Moffett Field, California, January 1991.
17. Gustafson, J., Rover, D., Elbert, S., and Carter, M., "The Design of a Scalable, Fixed-Time Computer Benchmark", Journal of Parallel and Distributed Computing, 12, 1991, pp. 388-401.
18. Dongarra, J.J., "Performance of Various Computers Using Standard Linear Equations Software", Report CS-89-85, Computer Science Department, University of Tennessee, Knoxville, TN, July 22, 1993.
19. Dongarra, J.J., Martin, J. and Worlton, J., "Computer Benchmarking: Paths and Pitfalls", IEEE Spectrum, 24, 7, 1987, pp. 38-43.

20. Bailey, D., "Twelve Ways to Fool the Masses When Giving Performance Results on Parallel Computers", *Supercomputing Review*, August 1991, pp. 54-55.
21. Bradley, D.K. and Larson, J.L., "Performance Evaluation Using Application Programs: Toward a Rigorous Foundation", in "Proceedings of IEEE", 1993.
22. Amdahl, G., "The Validity of the Single-Processor Approach to Achieving Large-Scale Computing Capabilities", in "Proceedings of the American Foundation of Information Processing Societies", Washington, D.C., 30, 1967, pp. 483-485.
23. Amdahl, G.M., "Limits of Expectation", *International Journal of Supercomputer Applications*, 2, 1, 1988, pp. 88-94.
24. Dongarra, J.J. and Duff, I.S., "Advanced Architecture Computers", Technical Report CS-89-90, Computer Science Department, The University of Tennessee, Knoxville, Tennessee, Nov. 1989.
25. Hwang, K. and Briggs, F.A., "Computer Architecture and Parallel Processing", New York, McGraw-Hill, 1984.
26. Noor, A.K., "Parallel Processing in Finite Element Structural Analysis", *Engineering with Computers*, 3, 1988, pp. 225-241.
27. Worlton, J., "Toward a Science of Parallel Computation", *Computational Mechanics - Advances and Trends* (A.K. Noor, ed.), AMD-75, The American Society of Mechanical Engineers, New York, 1986, pp. 23-35.
28. Hwang, K. and deGroot, D. (eds.), "Parallel Processing for Supercomputers and Artificial Intelligence", McGraw-Hill, New York, 1989.
29. Almasi, G.S. and Gottlieb, A., "Highly Parallel Computing", Benjamin/Cummings, Redwood, California, 1989.
30. Trew, A. and Wilson, G. (eds.), "Past, Present, Parallel: A Survey of Available Parallel Computer Systems", Springer-Verlag, London, 1991.
31. "Resources in Parallel and Concurrent Systems with an Introduction by Charles Seitz", ACM Press, New York, 1991.
32. Lilja, D.J., "Architectural Alternatives for Exploiting Parallelism", IEEE Computer Society Press, Los Alamitos, California, 1992.
33. Fortes, J.A.B. and Wah, B.W., "Systolic Arrays - From Concept to Implementation", *Computer, IEEE*, 20, 7, 1987, pp. 12-17.
34. Hayes, L.J., "Systolic Arrays for Finite Element Calculations", *Parallel Computations and Their Impact on Mechanics* (A.K. Noor, ed.), AMD-86, The American Society of Mechanical Engineers, New York, 1987, pp. 229-238.
35. Law, K.H., "Systolic Arrays for Finite Element Analysis", *Computers and Structures*, 20, 1-3, 1985, pp. 55-65.
36. Melhem, R.G., "On the Design of a Pipelined/Systolic Finite Element System", *Computers and Structures*, 20, 1-3, 1985, pp. 67-75.
37. Moore, W., McCabe, A. and Urquhart, R. (eds.), "Systolic Arrays - Papers Presented at the First International Workshop on Systolic Arrays", Oxford, July 2-4, 1986, Adam Hilger, Bristol and Boston, 1986.
38. Conaway, J.H., "Structural Engineering Software on Small Computers", The American Society of Mechanical Engineers, New York, Paper 80-C2/Aero-7, 1980.
39. Furger, R., "Redefining the Laptop", *InfoWorld* 10, 45, November 7, 1988, pp. 47-49.
40. Brown, B., "Take It or Leave It - Portables with Desktop Power", *PC Magazine*, 7, 17, October 11, 1988, pp. 92-155.
41. LoPiccolo, P.J., "High-End Workstations", *Engineering Tools*, February 1988, pp. 80-95.
42. Gannon, D., Atapattu, D., Lee, M.H. and Shei, B., "A Software Tool for Building Supercomputer Applications", *Parallel Computations and Their Impact on Mechanics* (A.K. Noor, ed.), AMD-86, The American Society of Mechanical Engineers, New York, 1987, pp. 81-92.
43. Jordan, H., "Structuring Parallel Algorithms in an MIMD, Shared Memory Environment", *Parallel Computing* 3, 1986, pp. 93-110.
44. Nicolau, A., "A Development Environment for Scientific Parallel Programs", *Applied Mathematics and Computation*, 20, 1-2, 1986, pp. 175-183.
45. Zima, H. and Chapman, B., "Supercompilers for Parallel and Vector Computers", ACM Press, New York, 1991.
46. Fenves, S.J., "Potentials of Artificial Intelligence and Expert Systems in Computational Mechanics", *State-of-the-Art Surveys on Computational Mechanics* (A.K. Noor and J.T. Oden, eds.), American Society of Mechanical Engineers, New York, 1989, Chapter 15, pp. 493-513.
47. Dym, C.L., "Expert Systems: New Approaches to Computer-Aided Engineering", Part 1, in "Proceedings of the AIAA/ASME/ASCE/AHS 25th Structures, Structural Dynamics and Materials Conference", Palm Springs, California, May 1984, pp. 99-115.
48. Mackerle, J. and Orsborn, K., "Expert Systems for Finite Element Analysis and Design Optimization - A Review", *Engineering Computations*, 5, 2, 1988, pp. 90-102.
49. Taig, I.C., "Expert Aids to Reliable Use of Finite Element Analysis", *Reliability of Methods for Engineering Analysis* (K.J. Bathe and D.R.J. Owen, eds.), Pineridge Press, Swansea, United Kingdom, 1986, pp. 457-474.
50. Williams, A.D., "The Development of an Intelligent Interface to a Computational Fluid Dynamics Flow-Solver Code", *Computers and Structures*, 30, 1-2, 1988, pp. 431-438.
51. Fulton, R.E. and Yeh, C.-P., "Managing Engineering Design Information", in "Proceedings of the AIAA/AHS/ASCE Aircraft Design, Systems and Operations Conference", Atlanta, Georgia, September 7-9, 1988.
52. Parks, C.H., "Tutorial: Reading and Reviewing the Common Schema for Electrical Design and Analysis", in "Proceedings of 24th ACM/IEEE Design Automation Conference", 1987, pp. 479-483.
53. Gallivan, K.A., Plemmons, R.J. and Sameh, A.H., "Parallel Algorithms for Dense Linear Algebra Computations", *SIAM Review*, 32, 1990, pp. 54-135.
54. Gallivan, K.A., Heath, M.T., Ng, E., Ortega, J.M., Peyton, B.W., Plemmons, R.J., Romine, C.H., Sameh, A.H. and Voigt, R.G., "Parallel Algorithms for Matrix Computations", SIAM, Philadelphia, 1990.
55. Dongarra, J.J., Duff, I.S., Sorensen, D.C., and van der Vorst, H.A., "Solving Linear Systems on Vector and Shared Memory Computers", SIAM, Philadelphia, 1991.
56. Freeman, T.L. and Phillips, C., "Parallel Numerical Algorithms", Prentice Hall, 1992.
57. Demmel, J.W., Heath, M.T. and van der Vorst, H.A., "Parallel Numerical Linear Algebra", *Acta Numerica*, 1993, pp. 111-197.
58. Kung, H.T., "The Structure of Parallel Algorithms", *Advances in Computers*, 19, Academic Press, 1980, pp. 65-112.
59. Buzbee, B.L., "Uniquely Parallel Algorithms", *Parallel Computations and Their Impact on Mechanics* (A.K.

Noor, ed.), AMD-86, The American Society of Mechanical Engineers, New York, 1987, pp. 95-100.

60. Frederickson, P. and McBryan, O., "Parallel Superconvergent Multigrid", Multigrid Methods - Theory, Applications and Supercomputing. Lecture Notes in Pure and Applied Mathematics, Vol. 110, (S. McCormick, ed.), New York, Marcel Dekker, 1988, pp. 195-210.
61. Dongarra, J.J. and Sorensen, D.C., "A Fully Parallel Algorithm for the Symmetric Eigenvalue Problem", SIAM Journal of Scientific and Statistical Computing, 8, 2, 1987, pp.139-154.
62. Adams, L. and Voigt, R., "A Methodology for Exploiting Parallelism in the Finite Element Process", in "Proceedings of the NATO Workshop on High Speed Computations", NATO ASI Series (J. Kowalik, ed.), Springer, Berlin, F-7, 1984, pp. 373-392.
63. Storaasli, O.O., Nguyen, D.T., Baddourah, M. and Qin, J., "Computational Mechanics Analysis Tools for Parallel-Vector Supercomputers", in "Proceedings of the 34th AIAA/ASME/ASCE/AHS/ASC Structures, Structural Dynamics and Materials Conference", April 19-22, 1993, La Jolla, California, Part 2, pp. 772-778.
64. Boyle J., Butler, R., Disz, T., Glickfield, B., Lusk, E., Overbeek, R., Patterson, J. and Stevens, R., "Portable Programs for Parallel Processors", Holt, Rinehart and Winston, New York, 1987.
65. Dongarra, J.J., and Sorensen, D.C., "SCHEDULE: Tools for Developing and Analyzing Fortran Programs", MCS-TM-86, Argonne, Illinois: Argonne National Laboratory, November 1986.
66. Ware, W.H., "The Ultimate Computer", IEEE Spectrum, 9, 3, 1972, pp. 84-91.
67. Flatt, H. and Kennedy, K., "Performance of Parallel Processors", Parallel Computing (to appear).
68. Gustafson, J.L., Montry, G.R. and Benner, R.E., "Development of Parallel Methods for a 1024-Processor Hypercube", SIAM Journal of Scientific and Statistical Computing, 9, 4, July 1988, pp. 609-638.
69. Gustafson, J.L., "Reevaluating Amdahl's Law", Communications of the ACM, 31, 4, 1988, pp. 532-533.
70. Storaasli, O.O. and Carmona, E.A. (guest eds.), "Parallel Methods on Large-Scale Structural Analysis and Physics Applications", Special Issue of Computing Systems in Engineering, 2, 2-3, 1991.
71. Noor, A.K. and Venneri, S.L. (guest eds.), "High-Performance Computing for Flight Vehicles", Special Issue of Computing Systems in Engineering, 3, 1-4, 1992.
72. Belytschko, T., and Gilbertsen, N., "Concurrent and Vectorized Mixed Time, Explicit Non-linear Structural Dynamics Algorithms", Parallel Computations and Their Impact on Mechanics (A.K. Noor, ed.), AMD-86, The American Society of Mechanical Engineers, New York, 1987, pp. 279-289.
73. Liu, W.K., "Parallel Computations for Mixed Time Integrations", Numerical Methods for Transient and Coupled Problems, (R.W. Lewis, E. Hinton, P. Bettess, and B.A. Schrefler, eds.), Wiley, New York, 1987, pp. 261-277.
74. Ortiz, M. and Nour-Omid, B., "Unconditionally Stable Concurrent Procedures for Transient Finite Element Analysis", Computer Methods in Applied Mechanics and Engineering, 58, 1986, pp. 151-174.
75. Flanagan, D.P. and Taylor, L.M., "Structuring Data for Concurrent Vectorized Processing in a Transient Dynamics Finite Element Program", Parallel Computations and Their Impact on Mechanics, (A.K. Noor, ed.), AMD-86, The American Society of Mechanical Engineers, New York, 1987, pp. 291-299.
76. Keyes, D.E., "Domain Decomposition: A Bridge Between Nature and Parallel Computers," Adaptive, Multilevel and Hierarchical Computational Strategies, (A.K. Noor, ed.), AMD-157, The American Society of Mechanical Engineers, New York, 1992, pp. 293-334.
77. Carey, G.F., "Parallelism in Finite Element Modeling", Communications in Applied Numerical Methods, 2, 1986, pp. 281-287.
78. Flower, J., Otto, S. and Salama, M., "Optimal Mapping of Irregular Finite Element Domains to Parallel Processors", Parallel Computations and Their Impact on Mechanics (A.K. Noor, ed.), AMD-86, The American Society of Mechanical Engineers, New York, 1987, pp. 239-250.
79. Farhat, C.H. and Wilson, E.L., "A New Finite Element Concurrent Computer Program Architecture," International Journal for Numerical Methods in Engineering, 24, 1987, pp. 1771-1792.
80. Nour-Omid, B. and Park, K.C., "Solving Structural Mechanics Problems on the CALTECH Hypercube Machine", Computer Methods in Applied Mechanics and Engineering, 61, 2, 1987, pp. 161-176.
81. Irons, B.M., "A Frontal Solution Program for Finite Element Analysis", International Journal for Numerical Methods in Engineering, 2, 1970, pp. 5-32.
82. Hayes, L.J., "Advances and Trends in Element-by-Element Techniques", State-of-the-Art Surveys on Computational Mechanics (A.K. Noor and J.T. Oden, eds.), The American Society of Mechanical Engineers, New York, 1989, Chapter 7, pp. 219-236.

Table 1 - Levels of Parallelism

Level	Means to Achieve Parallelism	Performed by
Job level	Multiprogramming - overlapping and interleaving the execution of more than one program (I/O and CP operations). Multiprocessing - running two or more CPUs concurrently on different applications or on independent job streams of the same general application.	Operating system
Program level	Multitasking - decomposition of a program into two or more tasks (program segments) that can execute concurrently. This requires the tasks to have no data or control dependence. Microtasking - which permits more than one CPU to work on a program at the Do-loop level.	Software
Inter-instruction level	Concurrency among multiple instructions - This requires an analysis of the data dependency and is accomplished by dividing each instruction into suboperations, and overlapping the different suboperations on different instructions.	Compiler
Intra-instruction level	Pipelining - by dividing the instruction into a sequence of operations, each of which can be executed by a specialized hardware stage that operates concurrently with other stages in the pipeline. Very-long instruction word (VLIW) - performing multiple operations per instruction, each with its own address field.	Hardware

Table 2 - Architectural characteristics of some of the new and emerging U.S. and Japanese large supersystems

System/ Model	Architectural Configuration	Maximum Number of Processors	Processor Type	Central Processing Unit Clock Cycle Time (ns)	Maximum Main-Memory Capacity	Peak Computational Rate (GFLOPS)
CRAY-2	multiprocessor with shared memory	4	ECL	4.1	512 MW-DRAM	1.2
CRAY-C916		16	ECL	4.2	128 MW-SRAM	16
CRAY-3		16	ECL	2.0	128 MW	16
IBM ES/9000-982 VF	multiprocessor with dedicated buffer and shared memory	8	ECL	7.2	10.2 GB	4.5
Fujitsu VPP 500	highly parallel vector multiprocessor with distributed memory	222	GaAs and BiCmos	10	55 GB	355
Hitachi S-3800/480 water-cooled	multiprocessor	4	ECL	2	2 GB	32
Hitachi S-3600/180 air-cooled	single processor	1	ECL	4	1 GB	2
Hitachi S-820/80	single processor with multiple pipelines	1	ECL	4	1 GB	3
NEC SX-3/44R	multiprocessor with multiple pipelines	4	ECL	2.5	8 GB	25.6

Table 3 - Architectural characteristics of some of the massively parallel computers

System/ Model	Architecture	Maximum Number of Processors	Maximum Main Memory Capacity GB	Peak Computational Rate	
				Each Processor Node (MFLOPS)	Total (GFLOPS)
Thinking Machines Corp. CM-5	synchronized MIMD	1024 (expandable to 16,384)	32 (512)	128	128
Intel Paragon XP-S	MIMD, 2-D Mesh	2000 (expandable to 4,000)	262 (524)	75	150 (300)
MasPar MP-2	SIMD, 2-D Mesh and router	16,384	4	0.146	2.4
nCUBE 2	MIMD hypercube	8,192	262	4.1	34
nCUBE 3	MIMD hypercube	65,536	65,000	100	6,500
CRAY T3D	MIMD bidirectional torus topology	2,048	131	150	300
Meiko CS-2	MIMD variable topology	264 (256 Fujitsu + 8 Super SPARC)	36.8	200 Fujitsu 40/SPARC	51.2
Meiko Computing Surface i860/concerto	MIMD variable topology	136 (128 Intel + 8 SPARC)	5.1	80/Intel 12/SPARC	10.2

Table 4 - Classification of Instruction Types (See Ref. 23)

Type of Instruction	Number Operations	Number of Pairs of Operands	Examples
Scalar	1	1	$A = B + C$
Vector	1	1	$A_i = B_i + C_i, i = 1, N$
Systolic	M	1	Matrix operations, with data from rows and columns used repeatedly.
VLIW	M	N	Multiple operations per instruction, each with its own address field.

Table 5 - Extended Taxonomy of Computer Architectures (See Ref. 23)

Levels of Concurrency	Generic Instruction Types			
	Scalar	Vector	Systolic	VLIW
Serial	CDC-7600 IBM 360/95	CRAY-1 CYBER 205	WARP	
Parallel	BBN-Butterfly Hypercube	CRAY C916 ETA ¹⁰		
Clustered	Myrias	Cedar		

Table 6 - Characteristics of New 32/64-bit Chips/Processors

Name of Chip	Number of Transistors (in millions)	Speed and Clock Cycle	Peak Computational Speed
DEC 21064 (Alpha)	1.68	200 MHz (5 ns)	150 MFLOPS 300 MIPS
HP PA-RISC 7100	1.7	100 MHz (10 ns)	200 MFLOPS
Intel Pentium processor	3.1	66 MHz (15 ns)	112 MIPS
SGI/MIPS TFP	3.4	75 MHz (13.3 ns)	300 MFLOPS 300 MIPS

Table 7 - Different Phases of Finite Element Structural Analysis Steady-State (Static) Problems

Phase	Suitability for Parallelization/Vectorization
Input problem characteristics, element and nodal data, and geometry	Can be parallelized.
Evaluation of element characteristics	Easy to parallelize and can be vectorized.
Assembly	Requires special care for parallelization (e.g., node-by-node strategy) Difficult to vectorize.
Incorporation of boundary conditions	Easy to parallelize.
Solution of algebraic equations	Important to vectorize and parallelize.
Postprocessing	Can be parallelized and vectorized.

Table 8 - Impact of New and Emerging Computer Technology on Structures Technology

System	Impact on Structures Technology
<ul style="list-style-type: none"> • Supersystems (> 1.0 Gigaflop) e.g., CRAY 916 and CRAY-3 • Highly parallel systems, e.g., CM-5, Paragon XP/S, and CRAY T3D 	<ul style="list-style-type: none"> • New levels of sophistication in modeling structures • Expedite multidisciplinary analysis and design
<ul style="list-style-type: none"> • Workstations (3G machines)* • Workstation clusters • Microprocessors and chip technology (e.g., SGI/MIPS TFP and DEC 21064 (ALPHA) Chips) • Special-purpose firmware 	<ul style="list-style-type: none"> • Increase productivity of structural analyst/designer • Collaborative computing - design and manufacturing teams • Structural health monitoring systems (for detection and recording of damage) • Significant speedup of analysis/design modules
<ul style="list-style-type: none"> • AI knowledge-based, expert systems, and neural networks 	<ul style="list-style-type: none"> • Aid in initial selection and adaptive refinement of model, selection of model, selection of computational strategy, and in postprocessing
<ul style="list-style-type: none"> • Large data management systems and databases 	<ul style="list-style-type: none"> • Facilitate integration of analysis programs into CAD/CAE, and integrated product and process development systems

*3G machines refer to workstations with over billion bytes (Gbytes) of storage; over billion instructions per second (GIPS); and over billion floating-point operations per seconds (GFLOPS).

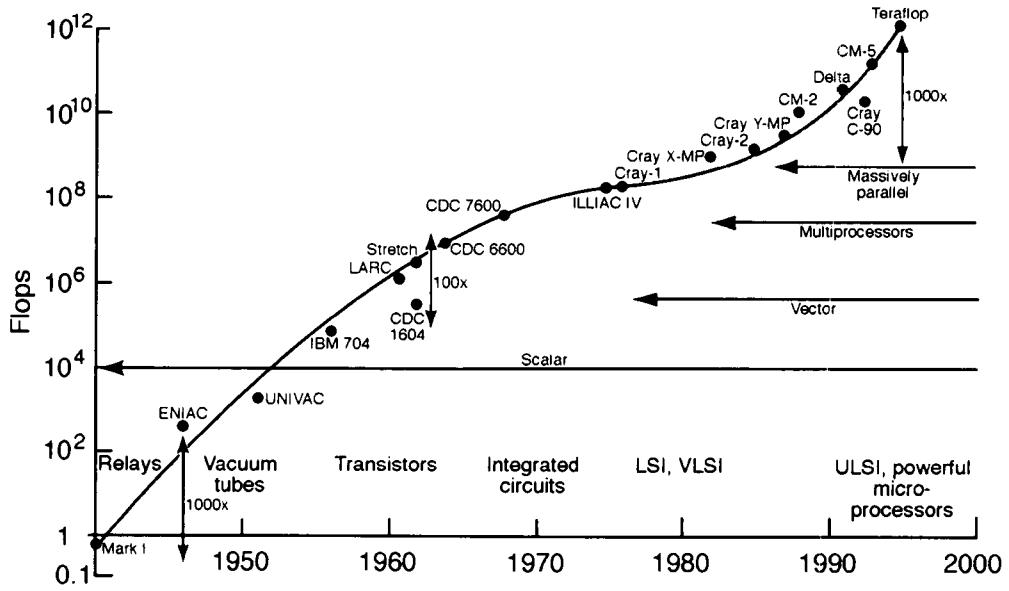

Fig. 1 - Growth of computer speed and the shift in hardware technology and computer architecture (see Ref. 1).

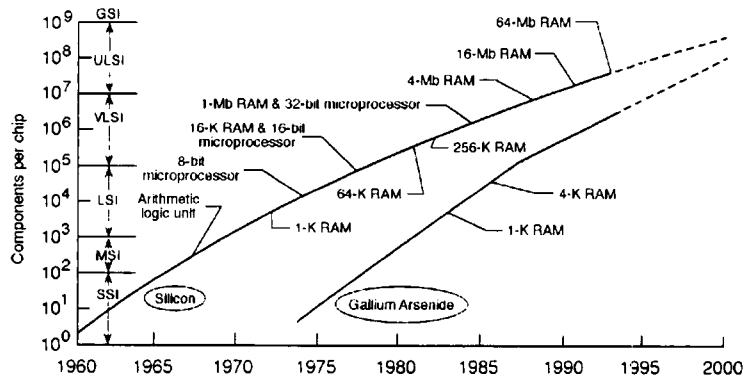

Fig. 2 - Growth of number of components per chip (see Ref. 2).

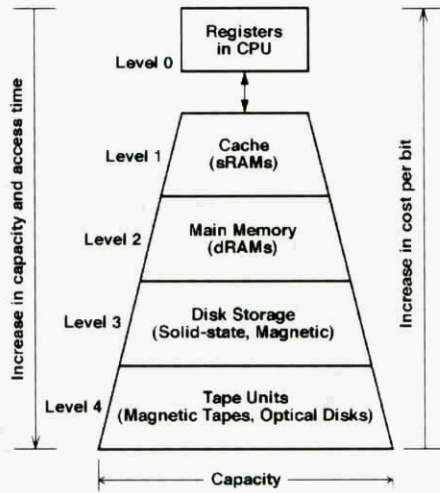

Fig. 3 - Memory hierarchy (see Ref. 5).

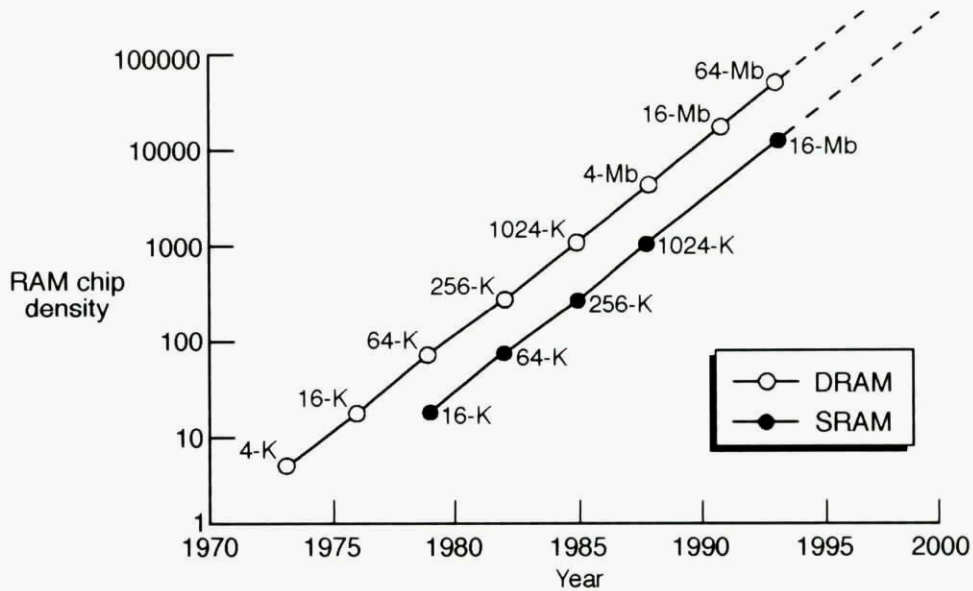

Fig. 4 - Trends in RAM chip capacity.

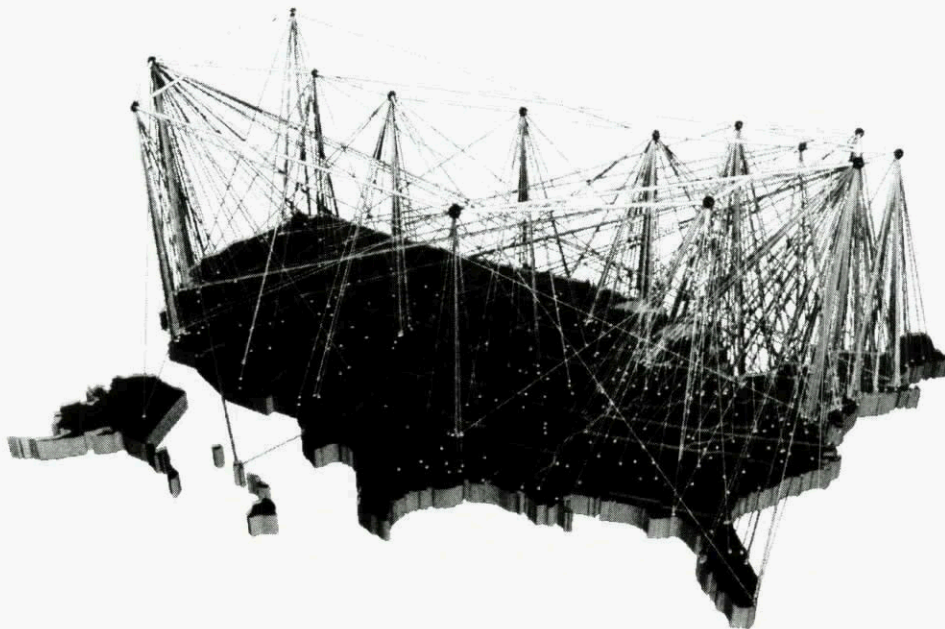

Fig. 5 - National Research and Educational Network.

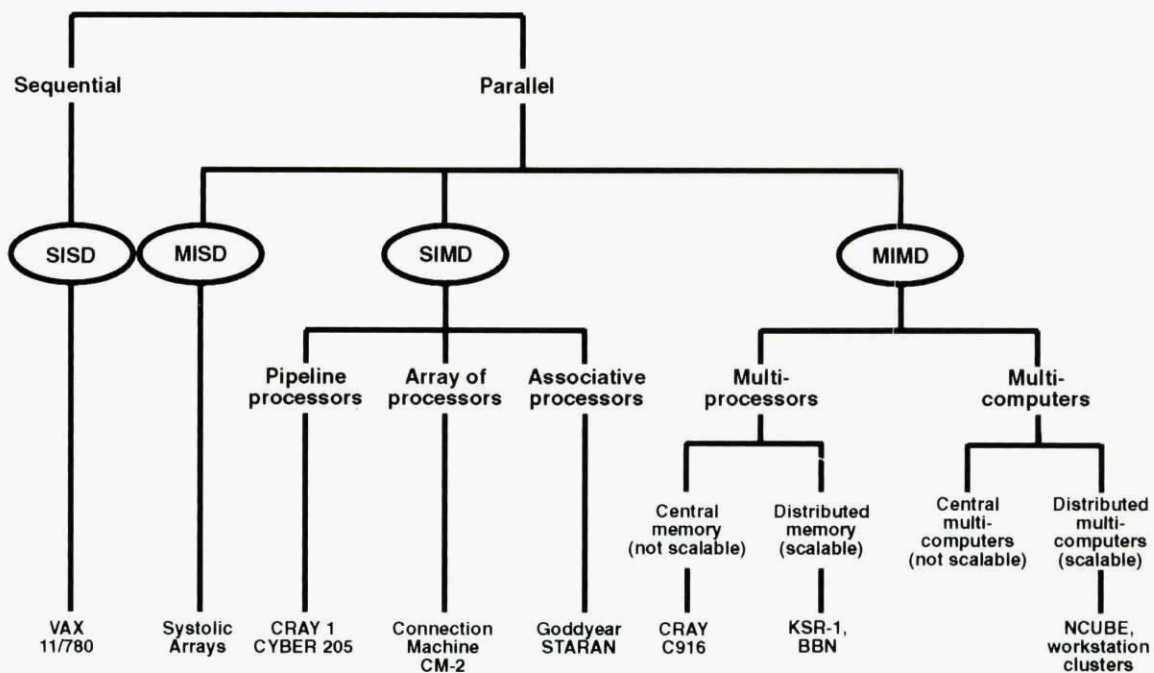

Fig. 6 - Classification of computing systems.

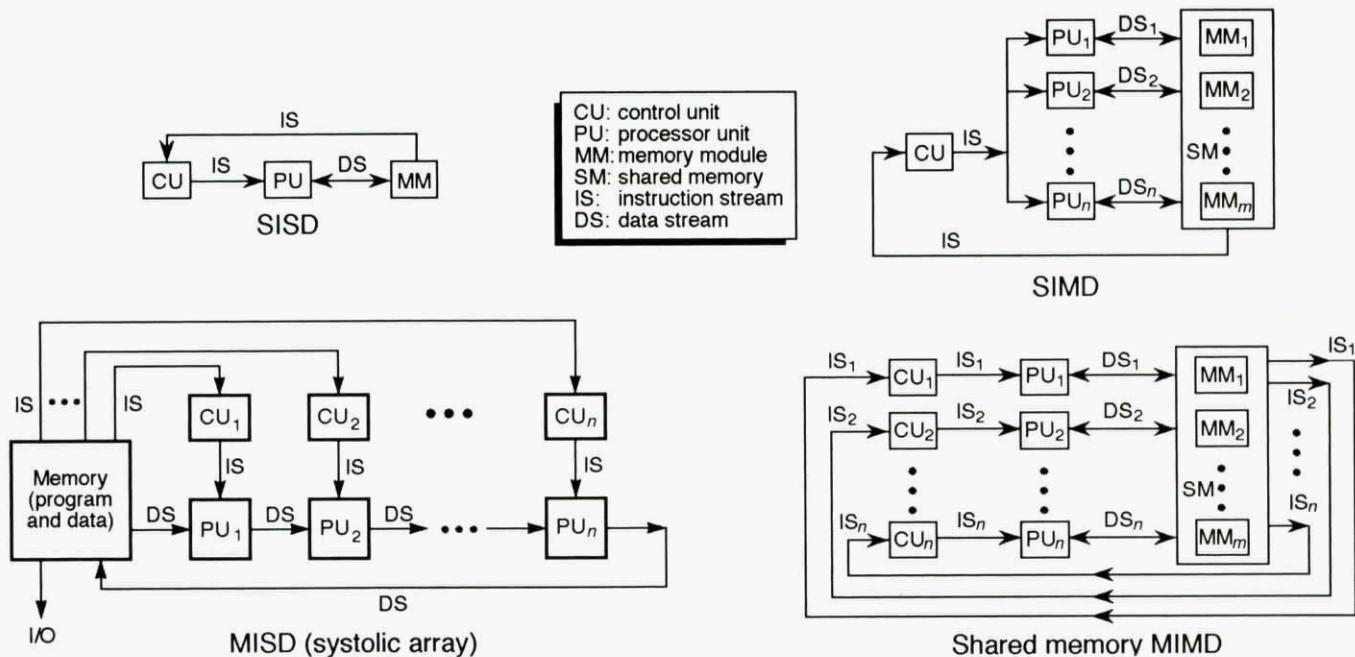

Fig. 7 - Block diagrams for SISC, SIMD, MISD and MIMD machines.

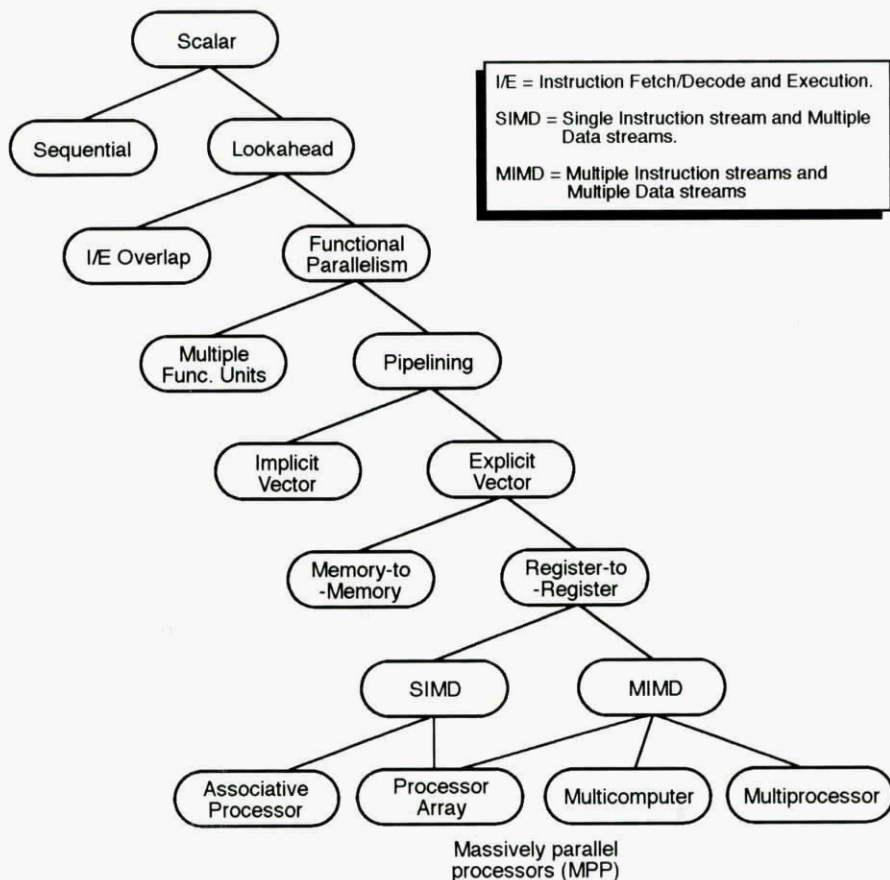

Fig. 8 - Architectural evolution of computing systems (see Ref. 5).

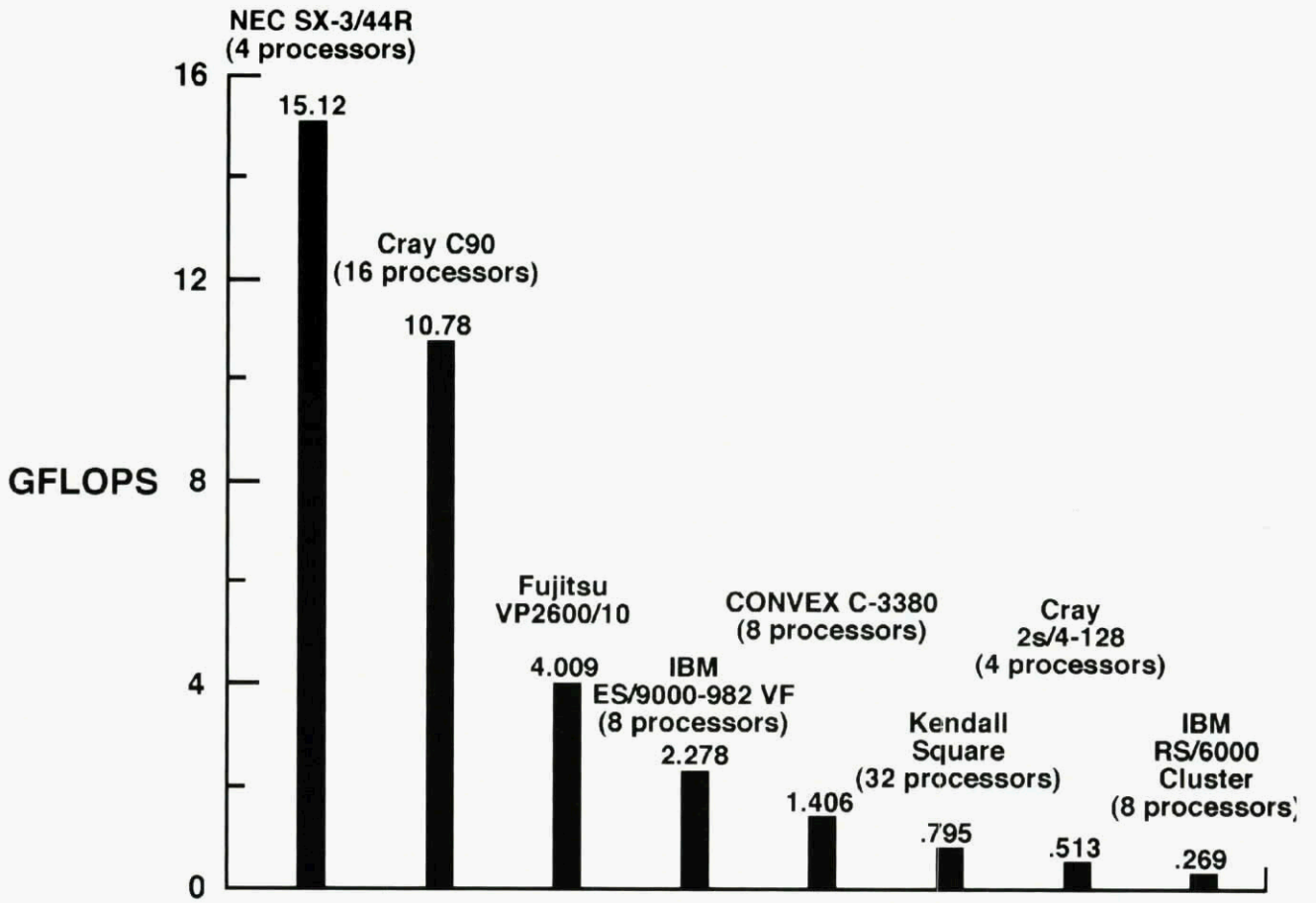

Fig. 9 - Sustained computer performance based on solution of 1000 dense equations using the Linpack package (see Ref. 18).

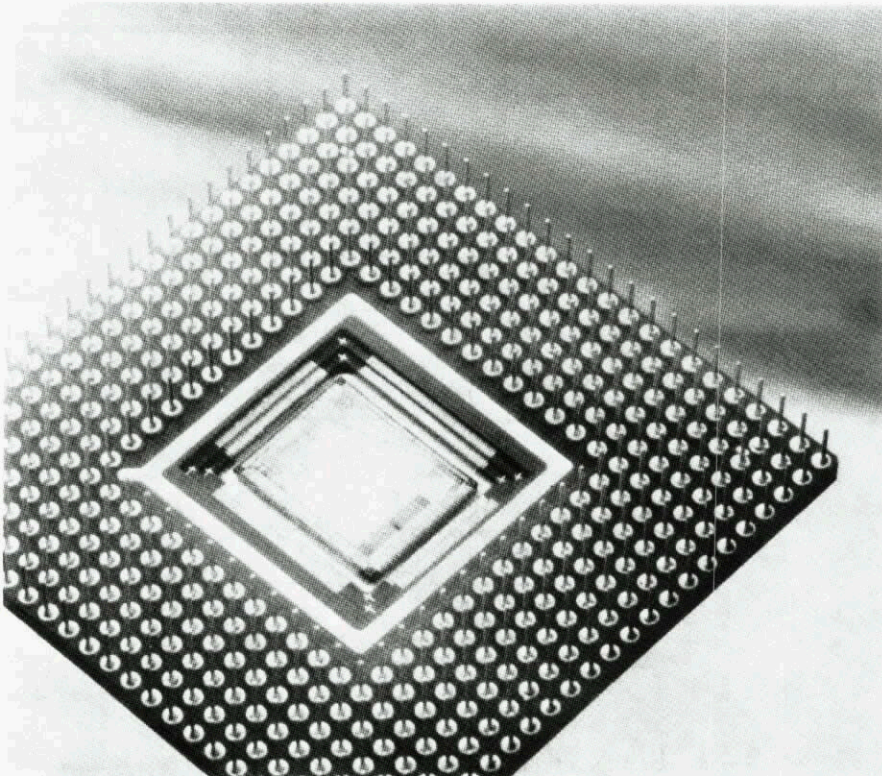

Fig. 10 - DEC 21064 (Alpha) microprocessor (64-bit RISC).

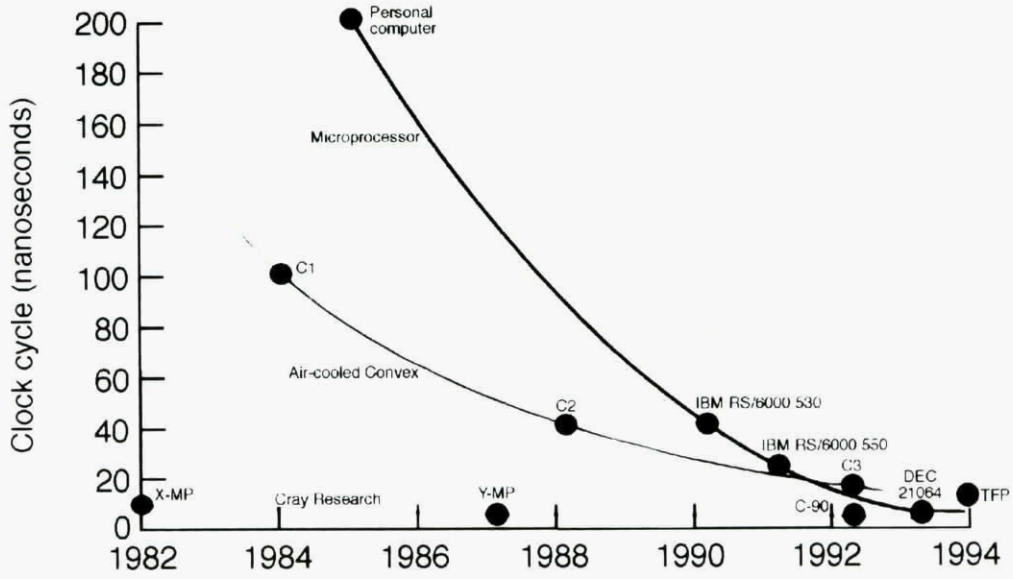

Fig. 11 - Progress in the clock speed for microprocessors.

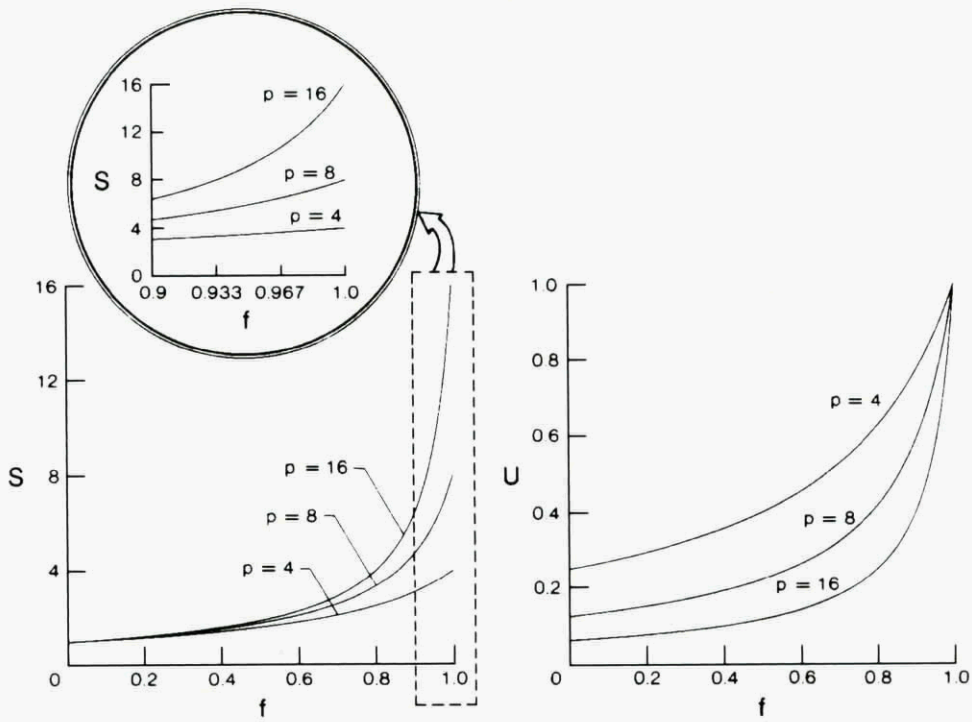

Fig. 12 - Theoretical speedup, S , and utilization rate, U , of multiprocessor systems as a function of the fraction of parallelism, f , and the number of processors, p .

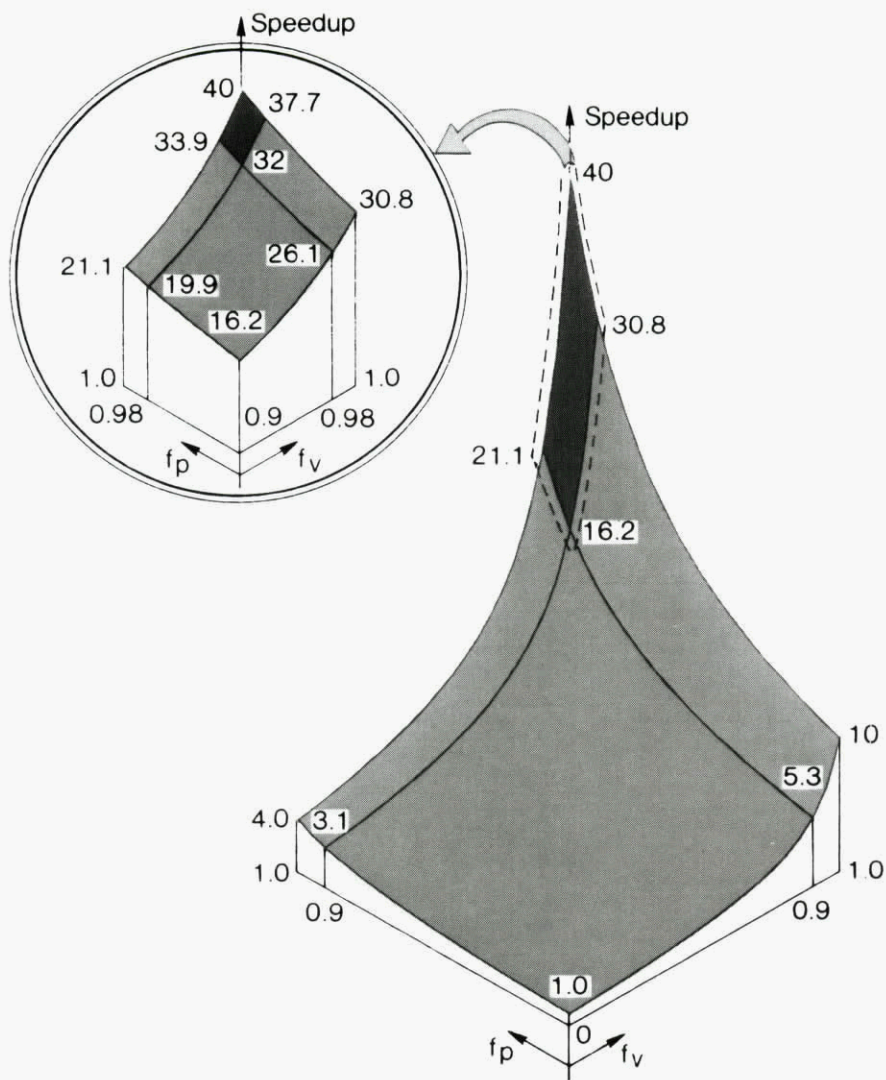

Fig. 13 - Theoretical speedup on a vector multiprocessor as a function of the fractions of parallelism and vectorization, f_p and f_v .

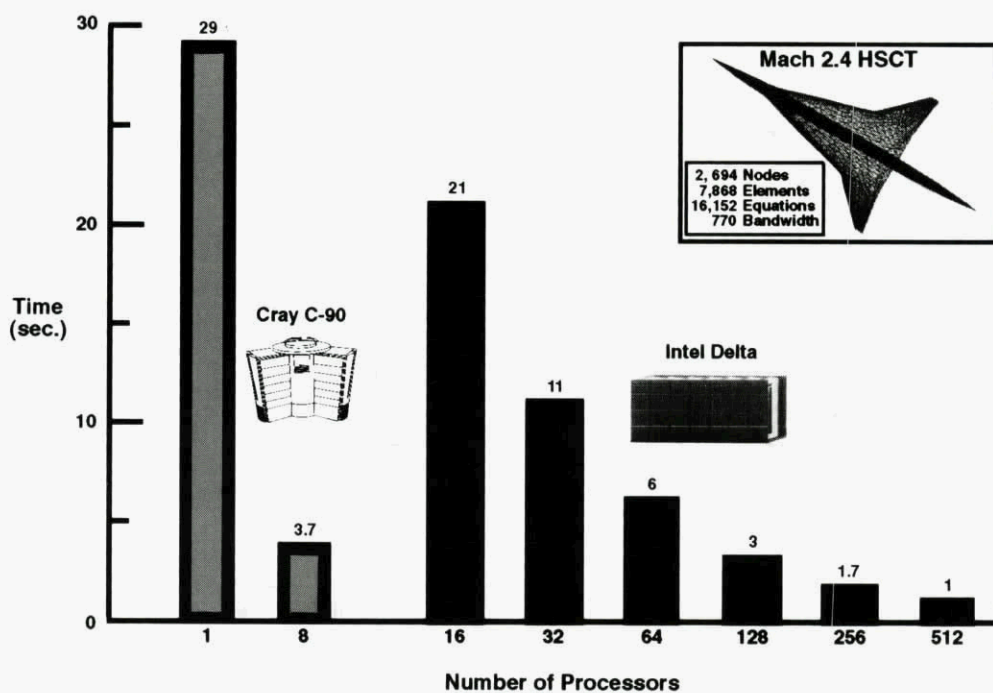

Fig. 14 - Performance of the node-by-node generation and assembly strategy on a 512-processor Intel Delta and a Cray C90 for a Langley Mach 2.4 High-speed Civil Transport (HSCT) model (see Ref. 63).

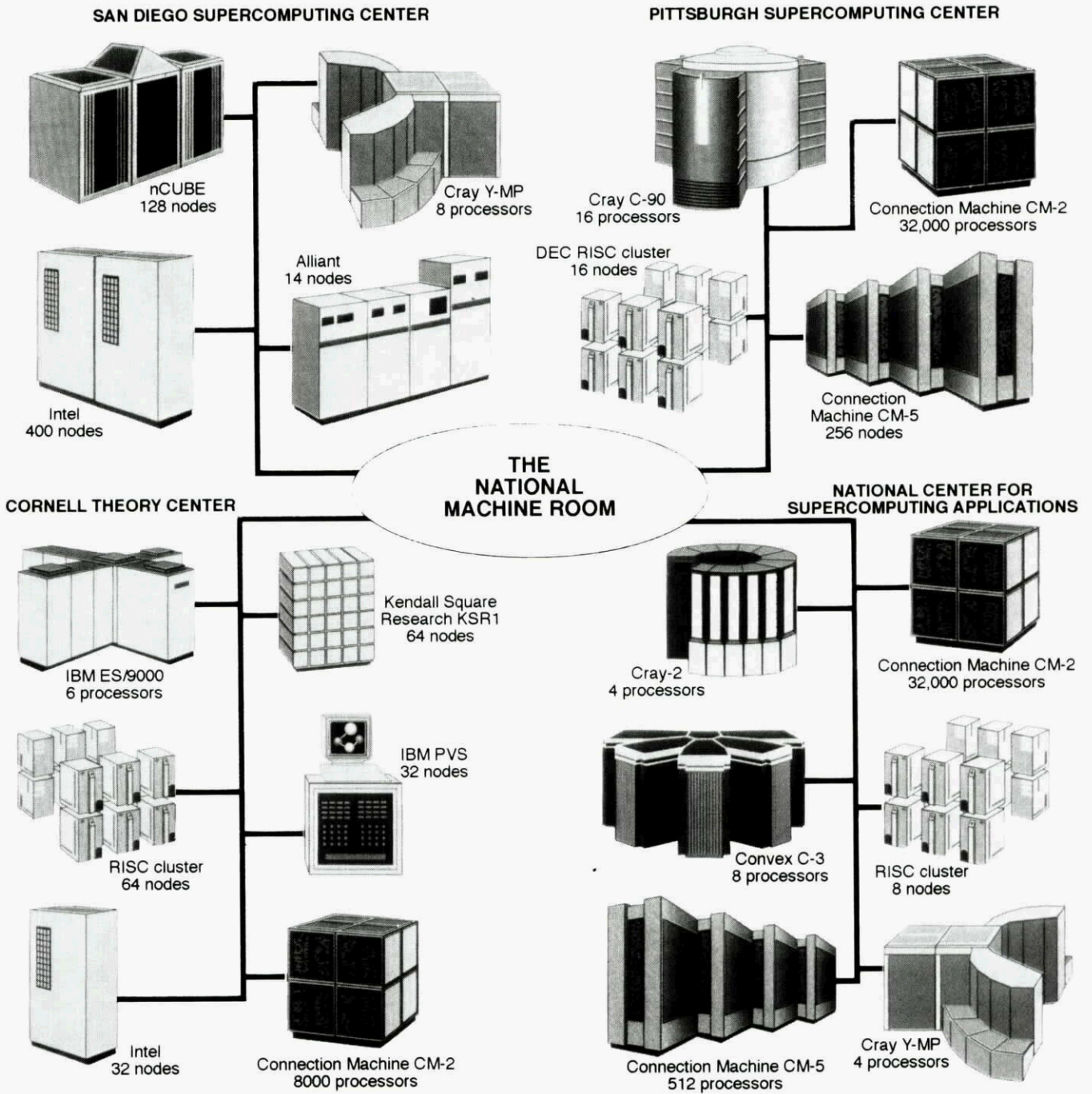

Fig. 15 - National Metacenter Concept (Virtual National Machine).

EARLY MANUFACTURING CONSIDERATIONS IN DESIGN

William C. Kessler
Gerald C. Shumaker
Michael F. Hitchcock

Manufacturing Technology Directorate
Wright Laboratory
Air Force Material Command
Wright Patterson Air Force Base
Ohio, USA

1. SUMMARY

The successful and timely transition of new product technologies to weapon systems depends heavily on the technical maturity, flexibility and cost effectiveness of the critical manufacturing processes and systems required to turn these technologies into tangible products. The whole concept of Integrated Product Process Development (a.k.a. Concurrent Engineering) encourages and facilitates the parallel design and development of these manufacturing processes and systems with the design and development of the product. As a result of new computer aided technologies and increased emphasis on manufacturing design, new tools and methodologies are emerging that will facilitate the early consideration of manufacturing in design. This paper will address the development of two such tools - Producibility Methodology and Tools and Virtual Manufacturing. These tools will enhance the effectiveness of manufacturing engineers who are integrated product process development team members and enable design engineers to better understand the potential downstream implications of early design decisions.

2. INTRODUCTION

The current aerospace environment is in a constant state of rapid change. Available defense resources are decreasing while at the same time the threat is much less predictable and the need for rapid response speed is heightened. As a result, the defense industrial base must provide a broad range of high quality products at reduced costs. The margin for inefficient processes is nonexistent. The resources simply do not exist any longer for the trial and error processes of the past. A new business strategy is required. Key requirements for this new strategy are:

- Make affordability and (weapon system) performance equal partners
- Decouple cost and quantity (economical lot sizes of one)
- Move toward "economies of scope" vs. "economies of scale" (Achieve the flexibility to handle multiple product lines which may each have low production)
- Effectively manage and leverage change

To respond to this challenge, it is critical that manufacturing be considered early in the design process. The approach to achieve this goal is aimed at developing a series of analysis and predictive tools that will provide for a more

complete and accurate design base for manufacturing. The intent is to fully support the design of manufacturing processes and systems over the entire life cycle, from concept development to disposal. The users of these tools would be both product design and manufacturing engineers, ideally working as an integrated team.

Two such tools are the subject of this paper: 1) Producibility Methodology and Tools, and 2) Virtual Manufacturing. The underlying improvements that contribute to the focus on producibility methodology are a focus on Integrated Product Process Development (a.k.a. Concurrent Engineering) and innovative approaches to variability reduction during the development of new products and processes. Virtual manufacturing concepts build from modeling, simulation and virtual reality technologies that are now possible with recent increases in computer capabilities.

An application analogy in this area is found in battlefield modeling and simulation, figure 1. Through a series of computer displays, animation and simulations, including person-in-the-loop, a battlefield modeling and simulation capability is being developed.¹ From this capability it is possible to begin to develop battlefield strategy tactics, test new weapon system concepts and evaluate alternatives.

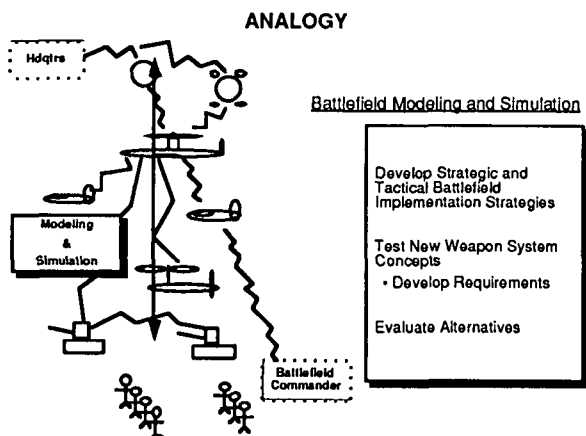

Figure 1: Battlefield Modeling and Simulation

An expansion of this analogy is the basis for the concepts presented in this paper, figure 2. If new weapon system requirements and concepts can be tested in a simulated battlefield scenario, it should be possible in the long term, to use improved analytical means and evaluate the potential cost, quality and throughput for production of these weapon systems. This evaluation should be completed before significant financial commitments are made. Multiple "what-if" scenarios could be evaluated to search for the best value to meet these weapon system performance requirements.

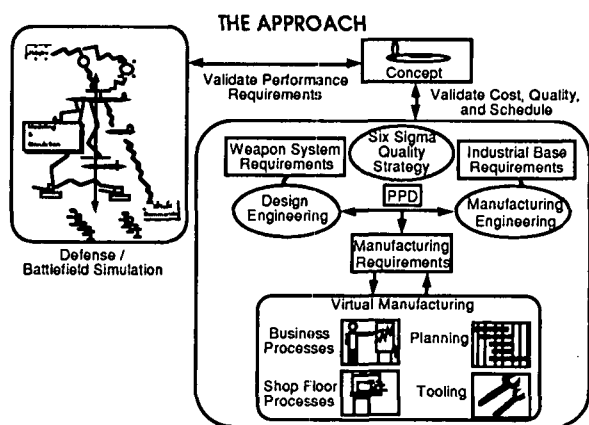

Figure 2: Strategy for Early Manufacturing Considerations in Design

3. OVERALL STRATEGY

The approach to early manufacturing considerations in design is based on the philosophy of assessing key manufacturing characteristics and requirements early in the product design phase. This assessment will allow manufacturing strategies to be developed in parallel with the design phases of the product. The intent is to identify and resolve areas of potentially high manufacturing cost and risk during the early phases of design, when the impact of product design change is least costly. It is believed that a proactive and comprehensive analysis of manufacturing, done early in design, will also lead to manufacturing being viewed as a true innovator on the team instead of a constraint on the creativity of the designer. In figure 2, the scenario depicted would have weapon system

design concept and requirements evaluated in a battlefield environment. These requirements would then be passed to an integrated engineering team that could evaluate the desired design characteristics vs. the affordability driven by manufacturing. In figure 2, the first issue is to address the interaction between the product designer and the manufacturing engineer. This interaction should be approached using Integrated Product Process Development (IPPD) concepts. The dialogue and product development balance would center around the ability of the product design to meet performance requirements while at the same time being manufactureable with cost effective, high quality, repeatable processes. The "first cut" at this design balance would be done using producibility analysis tools. The next level of detail in the design balance would then be done using Virtual Manufacturing techniques. Virtual Manufacturing would address areas such as business practices, planning, shop floor processes and testing.

with the most value are found. This involves assessing the producibility and cost risk of the designs established through a balanced product and process development (box 3), completing an overall factory assessment, using virtual manufacturing techniques (box 4) and thoroughly analyzing high risk, high cost shop floor processes, using virtual manufacturing techniques (box 5). All of the analysis and synthesis processes depicted in figure 3 can be done in a highly iterative manner using structured methodologies, state of the art computer tools, which support advanced modeling and simulation techniques, and a comprehensive manufacturing data base built from knowledge of world class manufacturing techniques. Additional discussions on producibility methodology and virtual manufacturing follow.

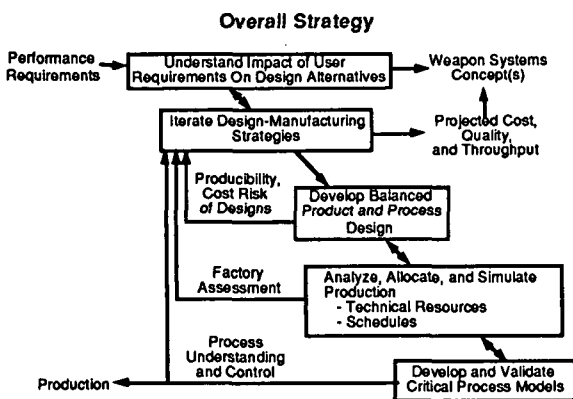

Figure 3: High Level Description of Approach

The high level description for the approach is shown in figure 3. At the very top level, the goal is to understand the impact of the user requirements on design alternatives. This top level design balance is obtained by assessing the various design and manufacturing strategies that could be employed to create and build the product (two way arrow from the top most box to second level). The lower 4 boxes in figure 3 depict the approach. The intent is to iterate design-manufacturing strategies until the one(s)

3.1 Producibility Methodology

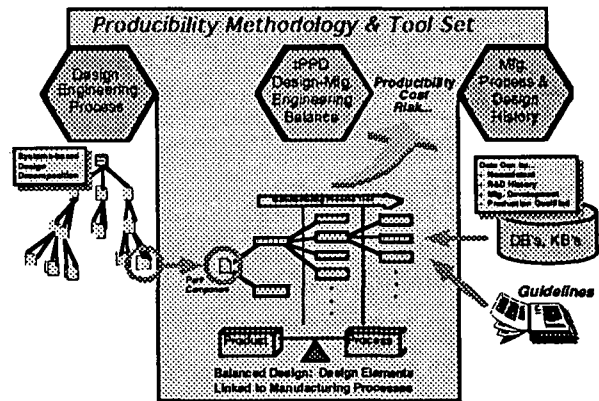

Figure 4: Producibility Methodology and Tools

A structured methodology proposed for assessing the producibility of product design is shown in figure 4. This figure depicts three keys aspects of producibility analysis. On the left, the design tree is broken down in a hierarchical fashion from the very top level - e.g. Weapon System, to the levels that depict the specific components and technologies that are used in the design of the component. In a new design, the engineer would identify the level at which key performance characteristics depend on critical components. Once the critical components are identified, the technologies that are used in the component

would then be identified. At that point, the manufacturing processes for that critical component and its technologies would be identified. This is shown as the horizontal tree in the middle portion of figure 4 - IPPD Design-Mfg Engineering Balance. The horizontal tree is used to depict the hierarchy of manufacturing processes that are required to manufacture the critical component identified by the tree on the left. The right hand portion of figure 4 illustrates the manufacturing data bases, guidelines and other critical bits of information about the manufacturing tree in the center. The overall strategy is as follows: 1) from the product tree, identify the critical components required to ensure that key performance characteristics are met, 2) construct a manufacturing tree that depicts the critical manufacturing processes that are essential to make the critical components, then, 3) identify what is known and unknown about these critical manufacturing processes. This involves examining how repeatable these processes are and the statistical likelihood that defects could result from a lack of process definition and control.

This approach has been captured as the Six Sigma³ Producibility Analysis⁴. The objective of Six Sigma is to provide a systematic and statistically based approach for designing products that are inherently producible. The Six Sigma Approach provides the capability to link individual manufacturing process variability to overall product producibility. A product designed and manufactured under the Six Sigma philosophy could have no more than 3.4 defects per million. The process capability indices for Six Sigma would be $C_p \geq 2$ and $C_{pk} \geq 1.5$ ⁵ Note there are two factors that enter into the process indices, the design robustness (numerator) and the manufacturing process variability (denominator). This goal is based on the realization that today's sophisticated products require hundreds of parts, processing steps and parameters to be controlled. The cumulative effect of defects during the manufacturing process can quickly drive the overall yield to an unacceptably low number.

Based on this analysis, manufacturing should iterate with design to see if suitable components and processes can be chosen that are better known and therefore more controllable using state of the art equipment, etc. If new components and manufacturing processes are deemed essential to the mission of the weapon system, this methodology can help identify the risk reduction projects that should be undertaken to ensure that the new components developed can be successfully transitioned to practice in the weapon system. An example of this approach is shown in figure 5.

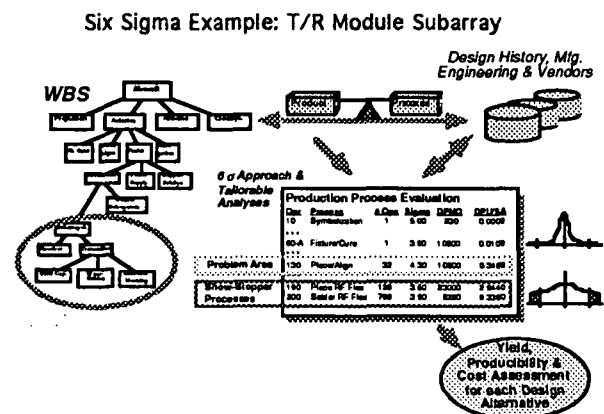

Figure 5: Six Sigma Example: Transmit/Receive Module Subarray

In this example, new weapon system performance characteristics were dependent on the transmit receive (T/R) module of the radar system, which was part of the avionics system. The critical components of the TR module were identified and an in-depth analysis was done on the manufacturing process required to manufacture these components. This analysis identified the variability, the potential Defects Per Million Operations (DPMO) and the Defects Per Unit/Subarray (DPU/SA). Those processes which have a relatively higher DPU/SA were flagged as potential "show-stopper" processes and required more process development to reduce risk. This methodology of identifying the risk of defects in the critical manufacturing processes, prior to committing to manufacturing, is a way to ensure that the technology developed has sufficient maturity to enable successful

transition to the implementation in a weapon system.

3.2 Virtual Manufacturing

The analysis tools available to a designer for performing initial assessments of product producibility provide a high level screening, based on knowledge of specific process constraints, to quickly “weed out” concepts which exceed targeted costs. However, manufacturing is not merely a collection of individual processes which can be defined by a set of design rules. Rather, manufacturing is a tightly coupled, interdependent set of functions operating as a system. Just as a weapon system cannot be truly understood without considering how its individual components operate together, neither can the manufacturing system. Going beyond the initial screening, to a point where producibility/affordability can be demonstrated and the true implications of design alternatives are understood, requires the ability to capture, represent and analyze the system of manufacturing relative to these designs. In essence, manufacturing the product in the computer is possible prior to ever committing production resources. This capability is embodied in a concept called Virtual Manufacturing (VM).

Virtual Manufacturing is an integrated, synthetic, manufacturing environment which is exercised to enhance all levels of decision and control across a products life cycle. The definition above illustrates several of the key elements and objectives of VM. First, VM will consist of an integrated and distributed set of both existing and future models and simulation tools, not a singular, monolithic solution. This will allow VM to be developed and implemented incrementally, capitalizing on models and simulation tools which already exist. Second, these distributed models used by VM will be synthesized and abstracted from the actual processes to be evaluated, thereby providing a direct linkage between the synthetic and actual production environments. This is a key

discriminator from most existing simulation approaches and allows VM to be used as both a decision support tool and for the analysis/control of manufacturing functions. Third, VM will provide consistency of representation as one progresses from the aggregated view of an enterprise to a detailed view of a shop floor. This allows users to simulate, with high confidence, manufacturing environments with differing levels of detail and from different perspectives, corresponding to the changing decision support and control requirements across a products life cycle.

It is important to note that VM does not require every process and function to be modeled in a computer. The development and implementation of VM will be driven by those processes and functions defined as constraints, either from a capacity or capability perspective. Additionally, VM will operate on an interactive basis with human operators, leveraging computerized and human knowledge to provide a level of VM functionality appropriate to the user.

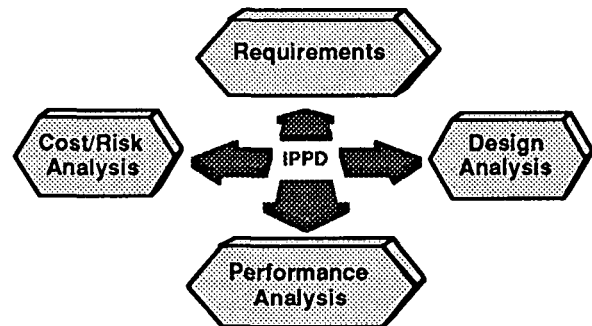

Figure 6: Weapon System Design Processes

Figure 6 depicts a scenario containing a simplified set of processes for designing a new weapon system which is useful in explaining how VM can be used. The user requirements, speed/payload/range/etc., feed the design function. Several design alternatives are generated using the IPPD tools discussed earlier. These options are returned in a format compatible with the virtual battlefield simulation tools. The battlefield effectiveness of the various options is defined and the more promising concepts identified. The key product

characteristics of the promising concepts are then used to feed the virtual manufacturing analysis for determining cost and risk estimates. VM tools are used to identify candidate manufacturing enterprise configurations for achieving the required product characteristics. For example, the required product speed demands high temperature materials, and therefore a key part of the enterprise to be analyzed involves high temperature processing capability. Information is abstracted from the resource and process models pertaining to the candidate enterprises, and used to drive the VM analysis and simulation. The results begin to provide answers to the questions:

- Can I make it
- What are the cost/risk drivers
- When can I have it?

This process iterates as manufacturing constraints are played against user requirements and design alternatives until an acceptable compromise is reached.

Fully realizing the vision of Virtual Manufacturing will take many years and require the development of a number of enabling technologies and capabilities. System architectures capable of supporting decentralized model-based simulation and control need to be identified. These architectures need to support the integration of existing models and manufacturing system components as well as provide the framework for new developments. Candidate approaches based on model federation and knowledge representation are being explored. Formalized models of manufacturing processes and resources are still lacking in many areas. Ad hoc resource models, contained in machine control systems for example, often exist, but little exists in the way of formalized process models. This is particularly acute for the intellectual processes such as design and planning. Additionally, there are technical constraints associated with aggregating and disaggregating model information with high fidelity. This is essential if VM is to maintain a

consistency of representation across the manufacturing hierarchy. Voids also exist in methods for effectively distributing models and simulation tools across a network of users. Finally, because VM represents a change in the way the government and industry currently does business, there are cultural and business practice barriers which must be overcome.

However, the picture is not all bleak. Complimentary initiatives, such as Agile Manufacturing and work underway for developing high speed network communication, are tackling many of the technical barriers. There are modeling, simulation and integration tools available today which allow us to begin implementing portions of the VM vision. By employing an incremental, building block approach for developing and implementing VM, near term cost savings can be achieved.

4. CONCLUDING REMARKS

This paper has presented concepts for the early consideration of manufacturing in the design process. In the future, it should be possible, using computer aided technologies, and data bases constructed from representative manufacturing situations, to fully analyze and project the potential cost, quality and throughput of a hypothetical set of components which would satisfy weapon system mission requirements. This analyses could be done early in the design process, so viable solutions could be found to problems before large financial commitments are made. Two tools that are critical to the realization of this goal, producibility methodology and tools and virtual manufacturing were discussed.

The producibility methodology and tool set included a structured approach to identify the components essential to performance and to identify the link to the manufacturing process. An approach, based on 6 Sigma Variability Reduction concepts, allows the potential number of defects to be identified based on a step-by-step

analyses of the manufacturing processes required to produce the component. Where the number of defects exceeds 3.4 parts per million, increased design robustness and/or increased manufacturing process development is recommended to reduce technology transition risk and increase the overall product and process quality.

Virtual Manufacturing is based on the integrated application of simulation, modeling and analysis technologies and tools. It allows the balancing of product performance and production impact across a products life cycle. VM will allow enterprises to evaluate the producibility and affordability of new product concepts with respect to risks, impacts on manufacturing capabilities and production capacity. VM will provide, prior to production, a "Build-in-the-computer" capability to prove the product is manufacturable, and an analysis of various production and supplier flow scenarios. Simulation and model-based control of manufacturing production will allow rapid response to changing customer and technology needs. For both defense and commercial users the cost and risk for introducing new products and processes will be reduced.

REFERENCES

1 "The Revolution Represented by DMSO (Defense Simulation & Modeling Office), National Defense, November, 1992

2 Producibility Methodology and Tool Set Initiative, WL/MTR, G. Shumaker, etal, May 1993

3 The "sigma" refers to the standad deviation in basic statistics.

4 M.J. Harry and J.R. Lawson, *Six Sigma Producibility Analysis and Process Characterization*, Motorola University Press, 1992.

5 $C_p = (\text{Spread in the design specification})/(\text{Spread in the process output})$

$C_{pk} = (\text{Spread between the process average and closest specification limit})/3 \text{ Sigma}$

APPLICATIONS OF CFD CODES AND SUPERCOMPUTERS TO AIRCRAFT DESIGN ACTIVITIES

W. Schmidt*)/P.W.Sacher**)
 Deutsche Aerospace AG
 D-81663 München
 Germany

Abstract*)

Integrated Design Technology has been pushed to a large extent by the tremendous progress achieved in the last two decades in the field of computational techniques with regard to flow simulation, engineering and manufacturing. This paper concentrates on the impact of CFD on the overall design process reviewed from the view of aircraft industry in Germany.

Selected examples will be given for applications of CFD during design and development of major products of European aerospace industry without claiming for completeness. General product categories and technology areas involved will be identified having large potential for CFD and supercomputing efforts. In addition present technology thrusts will be discussed and examples for the impact of CFD and supercomputing demonstrated by applications in various programmes will be given.

Introduction

CFD and supercomputing are supposed to help designing better products at lower risk.

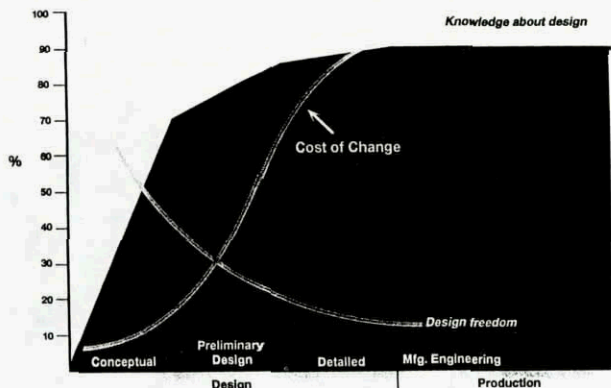

Fig. 1 Cost of changes vs. design freedom during A/C development
 (Source : M. Wozny, R.P.I., Symposium on information architectures for concurrent engineering)

According to the schematics in Fig. 1 the expected cost for changes in the various stages of the development

*) Director Air Vehicle Engineering
 Associate Fellow AIAA

**) Manager Hypersonics Technology Programme
 Member AIAA

process are increasing dramatically with progressing time. In contrary the freedom for the designer to make changes is more and more reduced. The message is that CFD and supercomputing has to be applied to a large extent during early conceptual and preliminary design stage where design freedom exists at low cost concerning changes with regard to the systems concept. So far the risk not to achieve a successful product at minimum development cost is controllable.

Motivation for aerospace industry

Major products of aerospace industry are categorized as follows :

- Civil aircraft
 - general aviation aircraft
 - transport aircraft
 - helicopters
- Military aircraft
 - combat aircraft
 - trainer aircraft
 - transport aircraft
 - helicopters
- Military rockets and missiles
- Space transportation systems
 - rocket launchers
 - reentry vehicles
 - winged airbreathing launch systems
 - transfer vehicles (terrestrial, extraterrestrial)
- Space systems
 - satellites
 - space stations

These product families have to be analyzed individually concerning the potential impact of CFD and supercomputing during design and manufacturing with respect to

- cost
- time
- quality and
- risk.

In addition the required specific product properties play an important role on the decision to what degree CFD and supercomputing have to be applied, e.g.

- performance
- operating cost
- operation risk
- life time
- life cycle cost
- environmental impact
-

The next step is to identify the technology areas involved during the design process where CFD and super-computing will have significant impacts on product success. It is obvious that nearly all engineering disciplines may benefit to a large degree e.g.

- Flight physics
 - aerodynamics/aerothermodynamics
 - propulsion integration
 - flight dynamics/trajectories
 - signatures
 - ...
- Structures and materials
- Propulsion systems
- Subsystems
 - guidance and control systems
 - communication systems
 - ...
- Systemsintegration
 - simulation
 - general performance
 - ...
- Tests and verification

Certainly, this list could be continued but it is important to consider these technology areas involved more in detail with regard to the expected magnitude of benefit gained. This leads to presently observed trends for mayor efforts in industry due to technology thrust e.g. in the fields of

- Flight physics
 - boundary-layer and flow-separation control (e.g. laminarization)
 - improvement of high-lift systems (e.g. for civil transport A/C)
 - prediction of aerothermodynamics (e.g. for space transportation systems)
 - development of advanced flight control systems (e.g. for supermaneuverability)
 - validation of numerical methods for analysis and optimization (all industrial products)
 - numerical methods for radar and infrared signature analysis (e.g. for combat A/C)
- Materials and structures
 - fibre materials/high temperature resistant materials
 - smart materials
 - computer aided design/optimization and manufacture
- Propulsion systems
 - engine/airframe integration
 - fuel efficiency/pollution reduction
 - hypersonic airbreathing engines (RAM/SCRAM)
 - cryogenic fuels
 - noise reduction

Present situation

The present situation in aircraft industry with regard to CFD and supercomputing for the prediction of aerody-

namic characteristics of complex A/C configurations can be characterized as Fig. 2 shows.

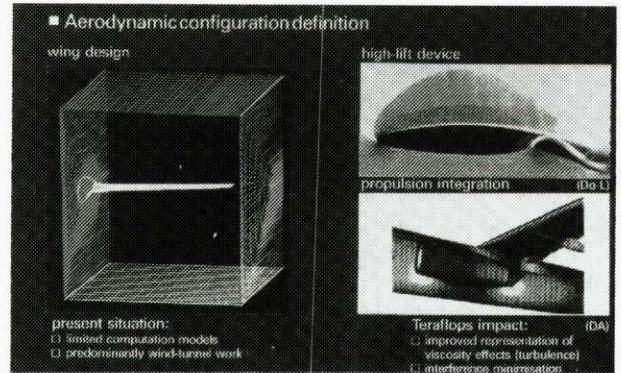

Fig. 2 Impact of CFD and supercomputing on wing design, design of high-lift devices and propulsion integration

Limited computational models and predominantly wind-tunnel work can be found where improved representation of viscosity effects the prediction and minimisation of interference effects due to the integration of aircraft components is required. The situation in high speed aerodynamics is even worse because of the additional requirements for realistic representation of heat loads and real gas in numerical algorithms uses and due to the needs for highly effective (airbreathing) propulsion/airframe integration (Fig. 3). The question of achieving thrust minus drag as a positive figure dominates future designs for space transportation systems.

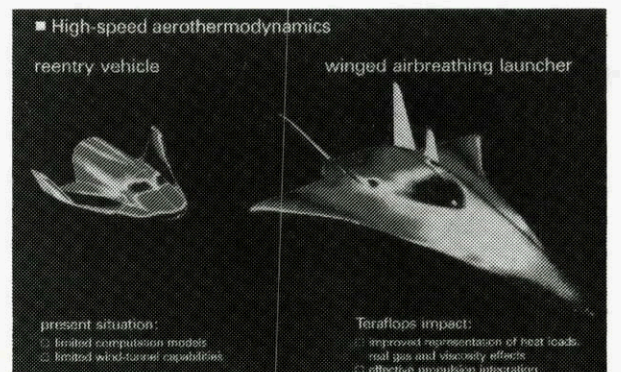

Fig. 3 Impact of CFD and supercomputing on high speed aerodynamics for reentry vehicles and winged airbreathing launchers

Grid generation techniques

Grid generation, both surface grids and 3D field discretization is the "Key" to successful computation in aerothermodynamics, and structures. Often underestimated this techniques used have required a high level of engi-

neering skill and experience.

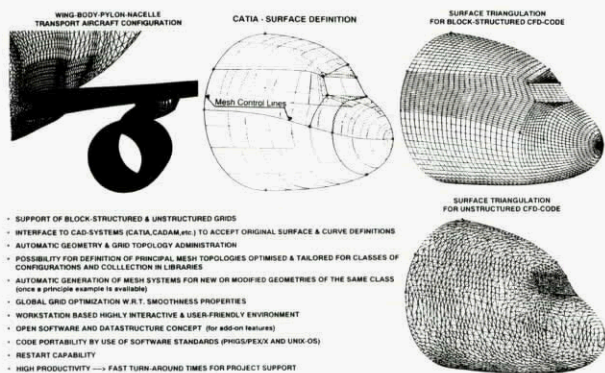

Fig. 4 DOGRID : Example for CFD-mesh generation system at Dasa Dornier

In Fig. 4 an example for surface grid generation for complex geometry is given. The main characteristics of the system are outlined in the figure.

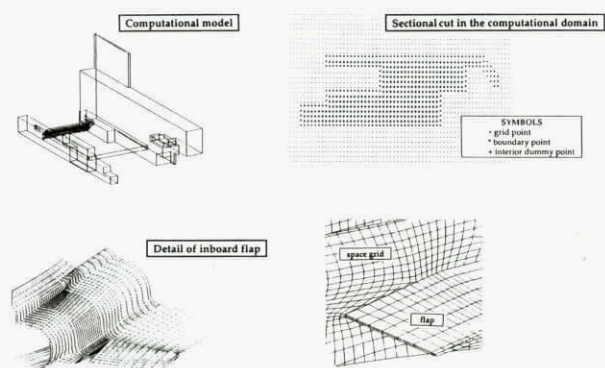

Fig. 5 Surface meshgrid generation from CAD-model for complete fighter A/C

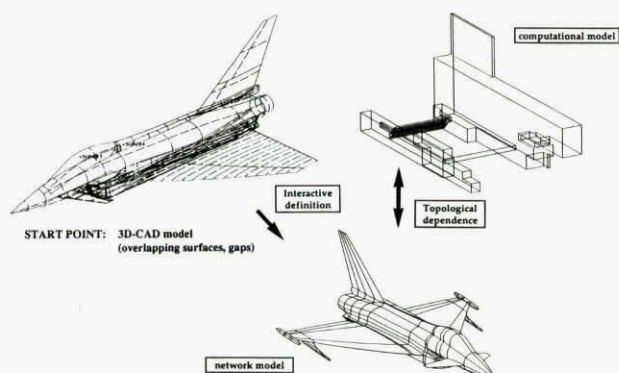

Fig. 6 Grid for Flap Modelling with a "Step"-Approach

In Fig. 5 an example is given for meshgrid generation starting from a CAD-model (e.g. CATIA) using an interactive procedure. In this process, starting from a 3D-CAD model with overlapping surfaces and gaps, a network model ("wireframe") is derived, with topological dependence to the computational model finally used for the flow computation.

Finally the representation of an aerodynamic control surface in the computational domain is shown in Fig. 6 again starting from the definition of geometry in the CAD system and resulting in the sectional cut for simulating the flap in the CFD numerical algorithm.

Engineering methods (potential flow)

Engineering methods still play a significant role during aircraft design and development. But the definition of engineering methods, as being more or less restricted only to "data sheets" and "Handbooks", has changed to a large degree. With the availability of PC's and work-stations on nearly each engineer's desk, engineering methods include now even the level of numerical methods in the complexity of panel methods ("Potential Flow Solutions") with and without viscous flow correction procedures.

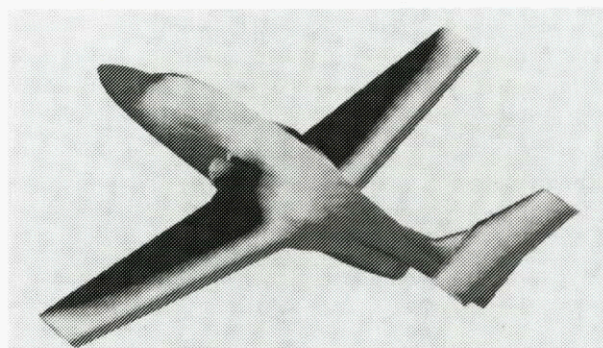

Fig. 7 JPATS-Fanranger surface pressure analysis using panel methods applied during design (HISSS at Dasa, $M = 0,5$, $\alpha = 5^\circ$)

Fig. 7 shows the pressure distribution on a complex subsonic trainer aircraft configuration obtained by an advanced panelmethod based on the numerical solution of the linearized potential flow equation. It is obvious, that this information, available in short time, plays an important role as a complementary tool to wind-tunnel tests. First a variety of configurational changes can be analyzed by numerical methods and then, finally only the optimized configuration will be verified by experiment.

In Fig. 8 the problems of the prediction of heat loads during aerothermodynamic pre-design of reentry vehicles is addressed. In contrary to more conventional designs

for subsonic, transonic and low supersonic speed, there is for hypersonic speed nearly no way to get realistic data from wind-tunnel work due to the lack of adequate (hypersonic) flow simulation. So the question comes up how to validate these numerical methods applied for the design of such vehicles. Maybe future hypersonic flight test demonstrators will provide an aerothermodynamic database obtained in realistic atmospheric environment during flight which can be used for code validation.

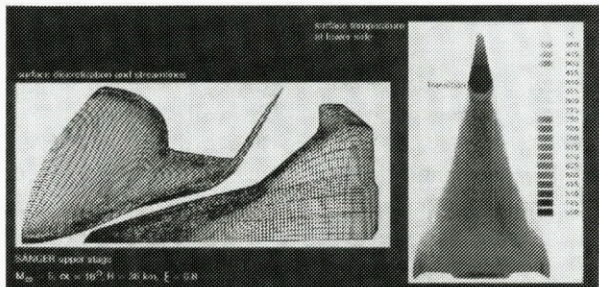

Fig. 8 Approximate methods used for the determination of heat loads at hypersonic Mach numbers

Inviscid flow simulation solving Euler equations

The next higher level of CFD is reached by solving the Euler equations to get the complete flow field around the vehicle at a given set of parameters like Mach number, angle of attack and side-slip. In contrary to potential flow methods Euler solutions represent the appropriate compressibility effects and they can deal with vortical type separated flow and realistic wakes. They provide in short time even more data about details of the whole flow field than the experiment usually provides. A typical example is given in Fig. 9 showing the results from flow analysis using the EUFLEX code developed at Dasa for a rather complex fighter aircraft configuration at $M = 0.9$ and $M = 1.2$ at $\alpha = 6^\circ$.

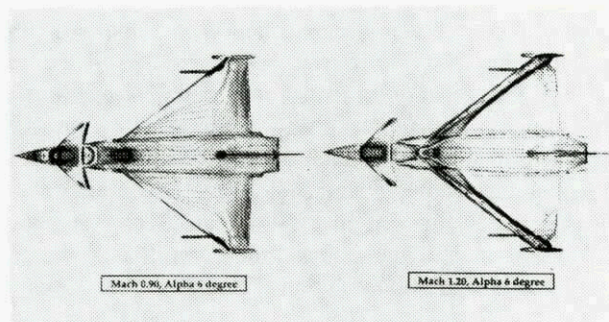

Fig. 9 Fighter Aircraft analysis using Euler Flow computations

Shown in Fig. 9 are isobars representing different levels of pressure by different colours. Interesting to note the difference of the pressure distributions at transonic and at supersonic Mach number, indicating, that for $M = 1.2$ the development of a shock system on the upper side of the wing takes place. Whether this leads to shock induced flow separation has to be investigated separately by coupling the code with a boundary layer method. But even without considering viscous effects, the agreement of numerical data with the experiment is excellent as Fig. 10 demonstrates.

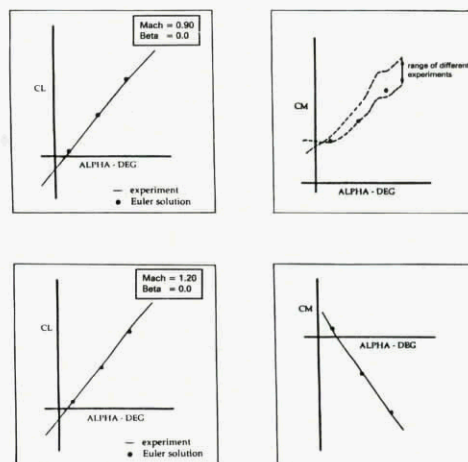

Fig. 10 Force and moment data at transonic ($M = 0.9$) and supersonic ($M = 1.2$) speed at 6° angle-of-attack. Comparison of numerical and experimental data.

The same situation holds for the prediction of the aerodynamic characteristics of missiles done by AEROSPATIALE in Fig. 11 for $M = 2.6$ at 10° incidence. The configuration shown here is even more complex than the previously discussed fighter aircraft geometry. Again colours are used to distinguish different levels of aerodynamic loads.

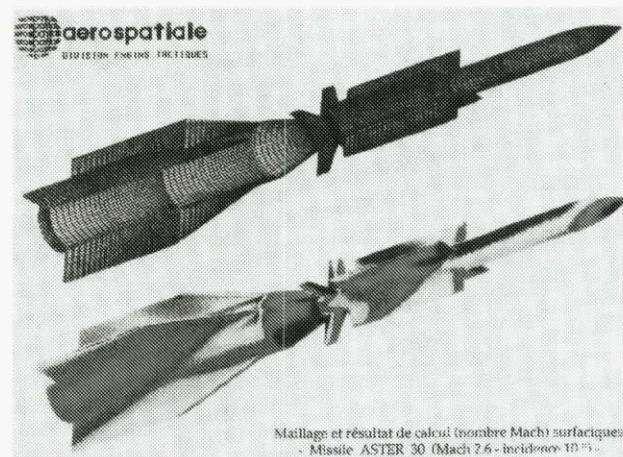

Fig. 11 Complex missile flowfield analysis at AEROSPATIALE. Euler solution at $M = 2.6$ and $\alpha = 10^\circ$

For completeness two examples are given for the application of Euler analysis of a two-stage-to-orbit (TSTO)

space transport configuration with (Fig. 12) and without (Fig. 13) upper stage ("orbiter") at transonic Machnumber ($M = 0,9$) and $\alpha = 10^\circ$.

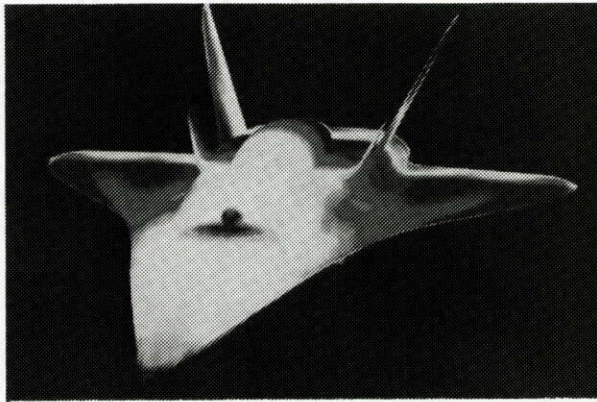

Fig. 12 Euler analysis of a TSTO-configuration at $M = 0,9$ and $\alpha = 10^\circ$ with upper stage

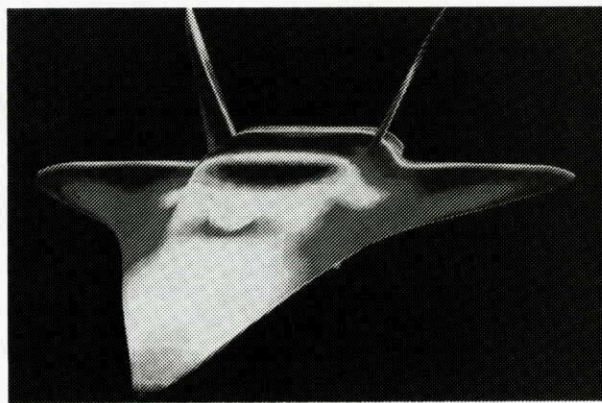

Fig. 13 Euler analysis of a TSTO-configuration at $M = 0,9$ and $\alpha = 10^\circ$ without upper stage

In both cases different pressures are correlated to different colours (red = high negative, blue low pressure level). It is clear, that by applying CFD codes the optimized integration of the upper stage with the lower stage can be achieved in much shorter time than by experimental investigations which can afford only a limited number of geometrical changes. The question of the feasibility of safe separation of both stages at a given Machnumber has to be addressed in a similar way using again CFD.

Finally an example for the capability of Euler solvers to predict the effect of separated flow of slender delta wings is given in Fig. 14. For a subsonic Machnumber ($M = 0.4$) at $\alpha = 10^\circ$ and zero side-slip the leading edge vortex separation is shown by a particle tracing postprocessing procedure. In addition to the prediction of the overall forces and moments (in the domain of nonlinear dependence from angle of attack) interference effects of the separated vortices on controls and even the vortex burst condition have been studied.

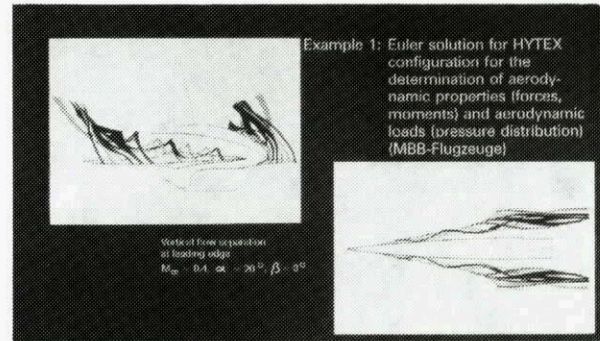

Fig. 14 Euler solutions for the prediction of leading edge vortex flow separation at slender delta wing configurations

Viscous flow simulation using Navier-Stokes solutions

In this chapter different applications are referenced to underline the power of CFD to investigate specific impacts of improved accuracy of flow simulation models like the representation of real gas, turbulence and wall surface properties. First in Fig. 15 wall stream lines on the HERMES reentry vehicle are shown, calculated by Dasa-Dornier using a Navier-Stokes analysis code for equilibrium laminar real gas flow conditions ($M = 10$, $\alpha = 30^\circ$ and $Re_L = 2.15 \cdot 10^6$). These results are compared with experimental data obtained from the wind tunnel at ONERA S4MA with deflected flaps by 10° in order to validate the prediction technique.

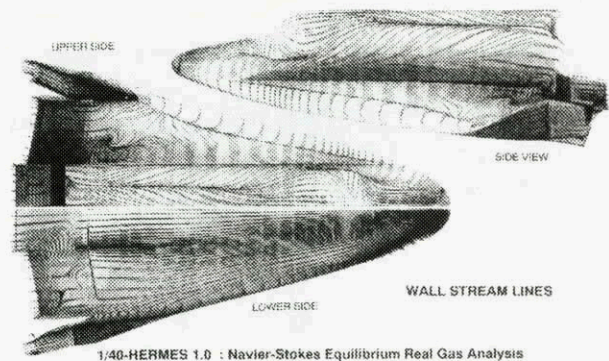

Fig. 15 Navier-Stokes equilibrium real gas analysis for the HERMES config. 1.0, 1/40 wind-tunnel model

In Fig. 16 another example is given from the RWTH Aachen for the application of a Navier-Stokes-code with real gas representation for a delta wing at hypersonic speed.

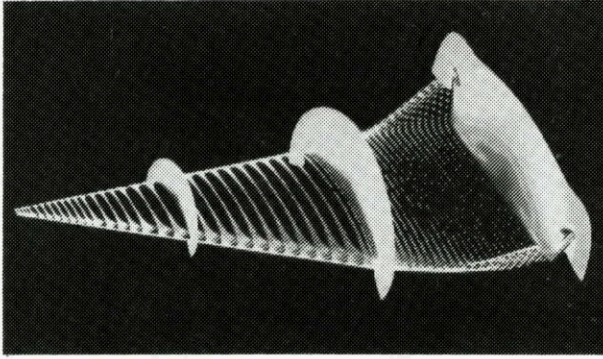

Fig. 16 Simulation of hypersonic flow at RWTH Aachen using Navier-Stokes solution with real gas effects

The next application deals with the problem of the interaction between the wall surface and the flow. Fig. 17 shows the important impact of heat radiation from the surface on wall temperature for an isolated delta wing and for the lower stage forebody lower surface centre line in x-direction of a TSTO space transportation system (German reference concept SÄNGER). As a consequence, similar results could be derived for the impact of the resulting wall temperature on friction drag. This numerical investigations have been performed at DLR in Göttingen and at Dasa in close cooperation. The picture also reveals the effects of transition from laminar to turbulent boundary layer flow. It is clear, that from such detailed information on the wall temperature the proper choice of materials and structures for future space transport vehicles is strongly influenced.

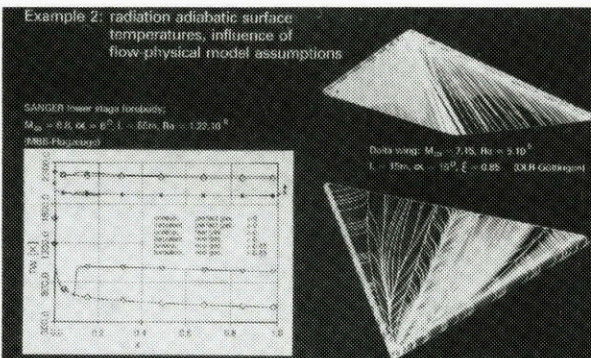

Fig. 17 Influence of flow-physical model assumptions on the prediction of adiabatic surface temperatures

Computational design tools developed for aeronautical applications have been used frequently as "Fall-Out" for development and design of car models to achieve geometries having low drag. Its clear that for this purpose

viscous effects and separation has to be taken into account. One example for this attempts is given in Fig. 18 by Dasa Dornier for a station wagon car model.

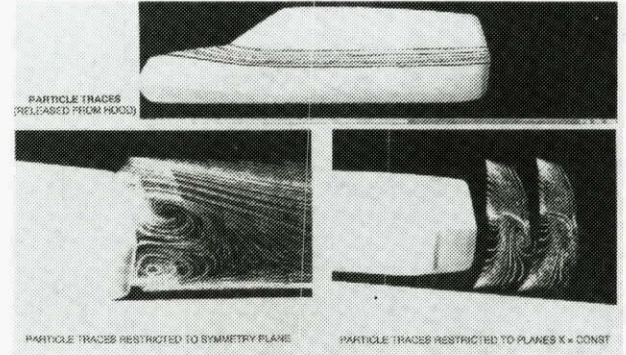

Fig. 18 Application of Navier-Stokes numerical flow simulation for the development of a station wagon car

Concerning the numerical simulation of turbulence an example is given in Fig. 19, being representative for the enormous efforts at universities in basic scientific research. The figure shows the results obtained at the University of Stuttgart for the instantaneous high-shear layers on a flat plate using 14.4 millions grid points for the numerical solution.

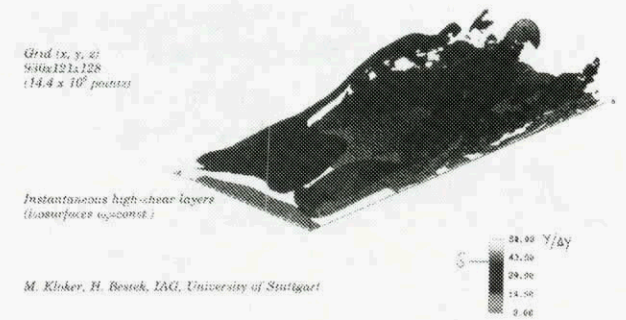

Fig. 19 Numerical simulation of instantaneous shear layers (Falkner-Skan-Boundary-Layer)

Applications for high angle of attack aerodynamics

High-Angle-Of-Attack (HAOA) aerodynamics attack one of the last remaining barriers for controlled flight - the barrier of attached flow. It is a key to improve maneuverability for fighter aircraft (to achieve "Supermaneuverability") and to improve safety of civil aircraft of any kind. In recent years several fighter aircraft have demonstrated the feasibility of safe and controlled flight in the so-called "Post-Stall" regime (e.g. HARV, SU 27 with Pugatjev Cobra-Maneuver) and even in a steady mode like in the US/German experimental aircraft X-31.

Fig. 20 shows the result of the HAOA analysis of the X-31 to perform supermaneuvers. The most important (time-dependent) flight parameters (alfa, beta, phi, speed, pressures and altitude) have to be predicted (first used for flight simulators on ground) and then verified in flight.

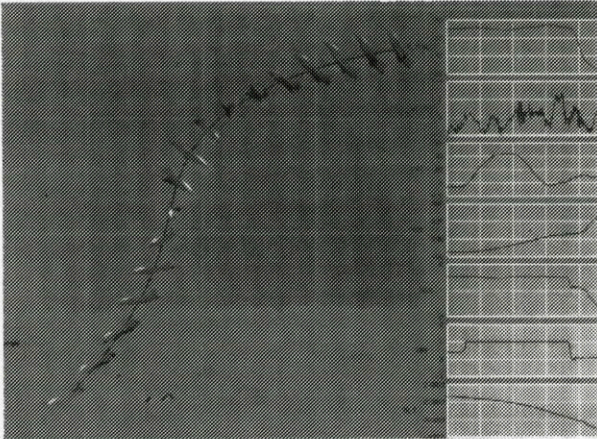

Fig. 20 The CFD-Challenge of HAOA analysis of X-31 supermaneuvers

To provide such efficient and reliable prediction tools, a European research initiative has been started in the early eighties. Fig. 21 shows the result from the Industrial European Programme Group (IEPG) on Task 15. On a simplified modular canard-wing-body model geometry, Euler flow simulation of canard-wing vortex flows at HAOA has been performed and validated by experiments in collaboration of several European countries (UK, NL, IT, GE).

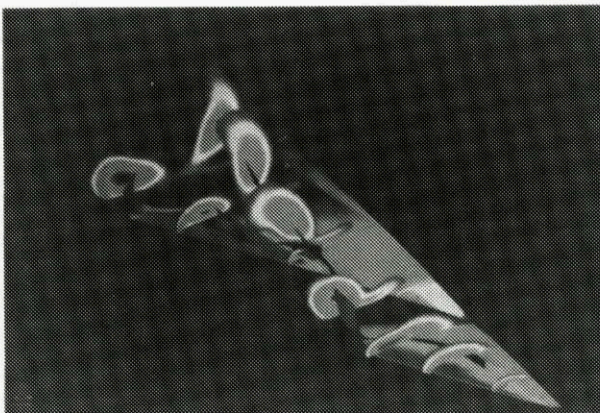

Fig. 21 Euler simulation of canard-wing vortex flows within the European research initiative IEPG TA 15.

The combination of fighter aircraft flying at HAOA and Missile firing leads to another challenge for numerical simulation. In Fig. 22 the result of such an investigation is shown.

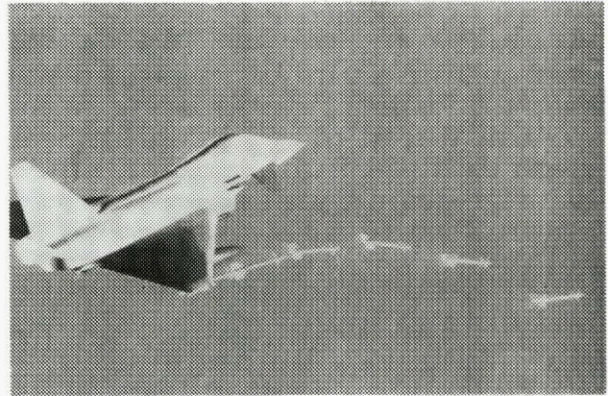

Fig. 22 Simulation of missile firing at HAOA using Euler solvers

Advanced project development related applications of CFD and supercomputing

It has been already mentioned, that many of the numerical techniques, developed originally for the purpose of aerodynamic flow simulation, have been used in aeronautical industry as a "Fall-Out" after adequate modifications for related relevant disciplines. In this chapter some of the most spectacular results obtained in Europe will be referenced, again without claiming for completeness. Examples are given for

- computational electro-magnetics (CEM)
- sonic boom prediction
- aeroacoustics
- aeroelastics
- icing

Radar cross section minimisation technique is a key element for survivability of military aircraft. Therefore numerical prediction techniques are used to a large extent for improving the design to achieve "Stealth" capability.

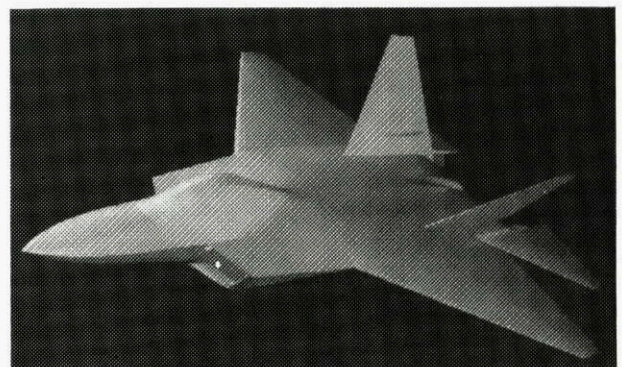

Fig. 23 CFD and CEM for YF-22 prototype analysis based on Dasa-Red-Team assessment

Fig 23 shows the geometry of the YF-22 prototype, where an effort war undertaken at a "Dasa-Red-Team" to assess CFD and CEM characteristics simultaneously.

One of the most significant and critical contribution to a large radar signature is the engine intake. Therefore the prediction of the radar cross section of the intake and its dependency from the aspect angle is a mandatory requirement for CEM. By using this techniques extensively during configurational design the position of the intake will be determined and often this is finally a result of a trade-off between aerodynamic functionality and radar reflection. Fig. 24 gives some data obtained at Dasa for a curved square to circular intake.



Fig. 24 Radar signature prediction for air intakes positioning and design

Since the renaissance of interest in supersonic transport (or even hypersonic flight using airbreathing propulsion) there is a renewed interest also in prediction (and minimisation) techniques for sonic boom patterns on ground. Using Jameson's airplane code recently new results have been obtained at Dasa for a Mach 3 airplane design. As Fig. 25 demonstrates, the agreement between numerical data and the experiment is surprisingly good. This holds even for the delta c_p pressure signature on ground.

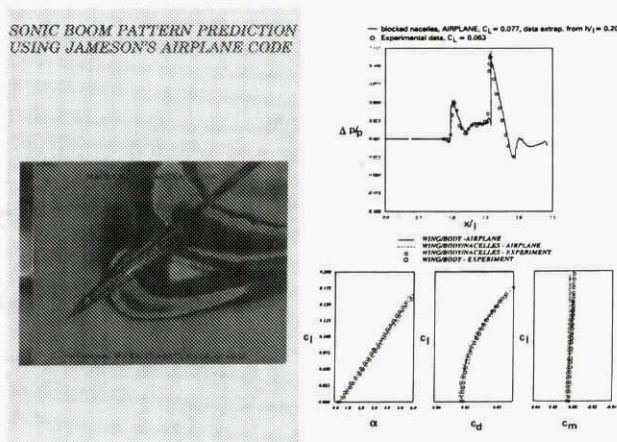

Fig. 25 Sonic boom pattern prediction using Jameson's airplane code

Aerodynamic noise reduction is of significant public interest in all countries. This poses a huge challenge specifically for the development of new helicopters. The

present situation is again characterized by limitations due to approximate models and no coupling of the flow field with the acoustic field. But there is hope that in the near future this deficiencies might be overcome by means of CFD and supercomputing. Fig. 26 shows some results obtained at DLR in Braunschweig for the prediction of the noise levels created by rotorblades.

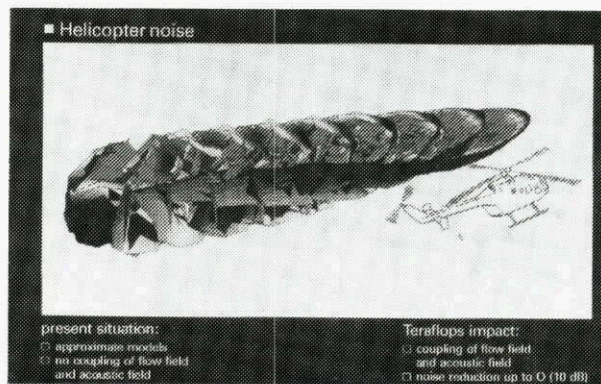

Fig. 26 CFD for the prediction of noise levels created by rotorblades of helicopters

The engineering problem of the coupling between aerodynamics and structures (aeroelastics) is currently characterized by small scale approximate interaction predictions. But real time coupling of the aerodynamics and structural dynamics will be addressed more and more. Fig. 27 reports on the results obtained during recent development of fighter aircraft.

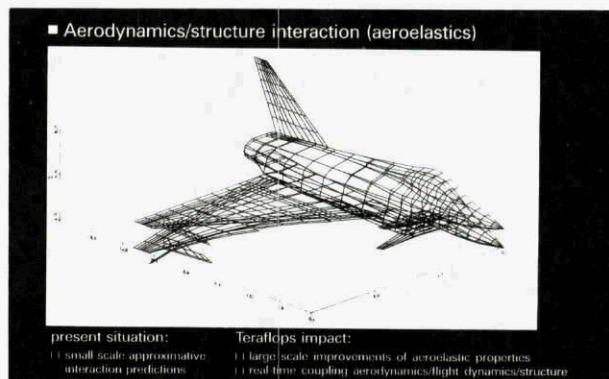

Fig. 27 Aeroelasticity - a challenge for supercomputing (Coupling of aerodynamics and structural dynamics)

The last example in this chapter is of great importance from an aircraft operational point of view. Flying in bad weather environment often leads to aircraft icing conditions. There are several possibilities to get rid of the ice but there is no way to avoid icing at all. The prediction of time-dependant growth of rime and glaze ice shapes based on the determination of water droplet paths and

impingement limits is a very well known technique using computing tools. Fig. 28 gives some results obtained for droplet paths and ice shapes for the Dornier Do 328 wing section.

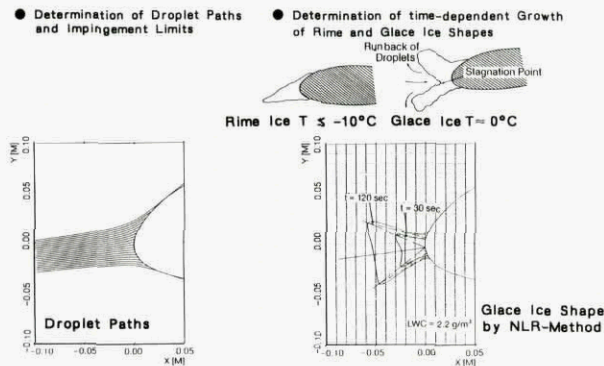
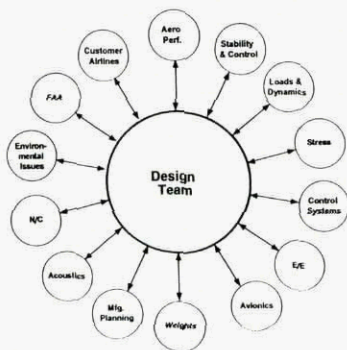

Fig. 28 Water droplet paths and icing on Do 328 wing section

Conclusions

It can be stated easily, that CFD and supercomputing is a mandatory requirement in concurrent engineering. The techniques used have reached, originally starting with computational aerodynamics, nearly all engineering disciplines. Much progress has been achieved in the past because everyone works on the same airplane at the same time. External support groups are working as consultants only. Fig. 29 defines the goal to be reached in performing concurrent engineering.



Progress into the past - everyone works on the same airplane at the same time
 Support groups are consultants only

Fig. 29 Concurrent engineering requires mandatorily CFD and supercomputing

The present status in aircraft design and optimization methods is still characterized by limitations due to numerical models and limited design/optimization capabilities. But as shown in the paper, there is significant progress. The development of highly enhanced numerical models and the development of procedures for improved optimum design is under way. Fig. 30 gives a schematic

view on the needs of interdisciplinary (concurrent) engineering process for an overall optimized product.

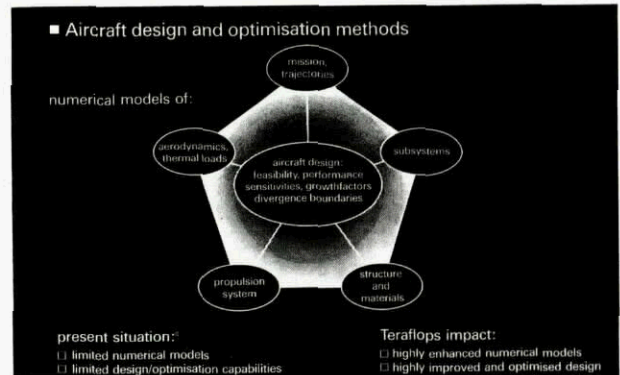

Fig. 30 Aircraft design and optimization methods

To conclude the following statements are made :

- CFD is by now a well-developed and accepted technology in Germany
- CFD is the basic design tool to reduce development risks and to introduce new technologies
- Interdisciplinary computational capabilities beyond CFD are in progress, combining CFD, Structural analysis, CEM, IR-analysis and optimization techniques
- Extensive progress has been achieved in mesh generation, by now permitting CFD for complex geometries
- There is excellent cooperation between universities, research establishments and industry in joint programmes, e.g. hypersonics, vortex flows, laminar and turbulent flow
- The use of supercomputers of all kind is required as intensively as possible (affordable), there are problems related to investment cost, short half life and change in architecture
- Complex flows at complex geometries demand genius engineers who understand the complete physics
 Progress in CFD and supercomputing has been achieved in Europe last not least due to several remarkable international initiatives (GARTEUR, IEPG, Vortex Flow Experiment etc.)

Acknowledgment

This paper has been assembled using material provided by colleagues from many different European institutions, industry and research institutes as well as universities. We therefore specifically appreciate the contributions and the friendly support obtained from AEROSPATIALE, DLR Göttingen, the Universities of Aachen and Stuttgart and from the Dasa subsidiaries Dornier, Deutsche Airbus and Military Division and Space Division.

PROBABILISTIC SIMULATION OF CONCURRENT ENGINEERING OF PROPULSION SYSTEMS

C. C. Chamis
NASA Lewis Research Center (M/S 49-8)
21000 Brookpark Road
Cleveland, Ohio 44135, U.S.A.

and

S. N. Singhal
Sverdrup Technology, Inc.
2001 Aerospace Parkway
Brookpark, Ohio 44142, U.S.A.

SUMMARY

Technology readiness and available infrastructure is assessed for timely computational simulation of concurrent engineering for propulsion systems. Results for initial coupled multi-disciplinary, fabrication-process, and system simulators are presented including uncertainties inherent in various facets of engineering processes. An approach is outlined for computationally formalizing the concurrent engineering process from cradle-to-grave via discipline-dedicated work stations linked with a common database.

1. INTRODUCTION

Engineering systems are presently developed by a loosely integrated procedure where the assigned tasks of each participating discipline are performed independently based on a building block approach. A typical example for a liquid propulsion system is shown in Figure 1. The present system development process is usually based on a series of ad-hoc revisions on an as-needed basis, with minimum interactions among participating disciplines. The system adequacy is then assessed based on extensive testing at sub-component, component, and system levels. This results in an inadequate, ineffective, inflexible, and costly system development process. Clearly, a need exists for a new way, concurrent engineering of the system development process.

Concurrent engineering is usually described as simultaneous processing of all participating disciplines involved in the total system development cycle, largely facilitated through tiger teams. The authors view concurrent engineering as the process through which all participating disciplines (from cradle-to-grave) interact concurrently through a common database to develop a system in the

minimum time frame possible, at the lowest cost obtainable, with desired durability and quantifiable risk/reliability. The infrastructure is available for computationally simulating concurrent engineering including probabilistic simulators to account for all the inherent uncertainties. The objective of this paper is to outline an approach for the computational probabilistic simulation of concurrent engineering for the multi-disciplinary procedure through which propulsion systems can be conceived, designed, developed, installed, operated, maintained, and retired.

2. WHY COMPUTATIONAL PROBABILISTIC SIMULATION OF CONCURRENT ENGINEERING?

The main impetus to find the new/better approach for developing systems in today's highly competitive market place is to minimize cost and development time while maintaining desired product durability/reliability. Does the concurrent engineering approach, focussed on formation of tiger teams, fulfill the required promise? The authors' contention is: the process of concurrent engineering needs to be computationally simulated, encompassing probabilistic aspects, i.e., including uncertainties at all stages, to reach the true minimum cost/minimum time benefits while maintaining true system durability/reliability. By this we mean, that all the relevant information from all the participating disciplines should be put in a common database and be accessible to all the participants concurrently from the day one of the process inception. Among many benefits such as first hand consideration of all relevant cradle-to-grave information at early stages of the process and instantaneous availability of the overview of all requisite information by all the participants, this will ensure that all revisions are instantly transmitted to all participating disciplines and

not just those that the tiger teams deemed appropriate as influencing the system outcome. Each participant can provide information on the variability their discipline will allow in the appropriate variables along with the consequences of crossing these bounds. Such a network will minimize the need for personal interaction in form of tiger teams and thus minimize parochial conflicts, while maximizing the flow of information. There will, of course, be a need for certain person-to-person meetings between the management and/or the discipline experts, but no need for frequent (time consuming and expensive) tiger team meetings.

3. INFRASTRUCTURE FOR PARTICIPATING DISCIPLINES

Clearly, concurrent engineering for the total system development/operation/maintenance/retirement cycle is a complex multi-disciplinary process. The formal development for computational simulation of the concurrent engineering process must (1) build on infrastructure already available for discipline-specific and integrated/coupled multi-discipline simulators for sub-components, components, and systems, (2) concurrently account for all multi-discipline uncertainties, (3) make use of available computer hardware, and (4) be open-ended for evolving advanced technology both in software and hardware arenas. Some of these computational simulators can be used to demonstrate in a limited way and on a specific case basis, that computational simulation of concurrent engineering is not only feasible but timely. This demonstration is a testament for the assessment of the readiness of the methodology for computationally simulating the concurrent engineering process. The following examples are selected to illustrate this point.

3.1 Structural Tailoring of Engine Blades - The aircraft, the engine, and the blade along with current design procedures and derived design results are shown in Figure 2 (ref. 1). This example shows that the computational simulation permits the design of a blade to meet system (engine) performance requirements (ROI -Return on Investment) in considerably reduced time. The design defines the blade in all its details with hot and cold configurations. These configurations can be transferred to numerically controlled machines to fabricate blades which match disk assembly requirements. In addition, structural

performance-specific values, for variables such as frequencies, displacements, and cyclic strains, are available which can be used for accept/reject quality criteria and for verification of blade designs.

3.2 Multi-discipline Tailoring of Turboprops - The turboprop stage/propeller and the blade internal structure along with results of the various participating disciplines are shown in Figure 3 (ref. 2). The tailored design specified the internal construction and the external geometry of the turboprops. All the details are in computer files which can be transferred to the shop to fabricate the blade. The fabrication requirements were formally represented by suitable constraints for (1) the type of composite and fiber volume ratio, (2) ply thickness and number of plies per node, (3) type of spar, (4) spar shape (5) type of adhesive, (6) cavity geometry, (7) angle of sweep, (8) twist angle, (9) camber and (10) airfoil geometry tolerances. Specific values of response variables are available which can be used to qualify, verify, and certify the turboprop. This specific example illustrates the multi-discipline infrastructure, beyond simple CAD/CAM that is needed to develop computational simulation of the concurrent engineering process.

3.3 Multi-Discipline Tailoring of Fan Blades - A more sophisticated coupled structural/Thermal/Acoustic/Electromagnetic Simulator was used for tailoring the composite configuration of a fan blade subjected to multi-disciplinary service loads. The results in Figure 4 (ref. 3) in-house unpublished notes) show the configuration for each discipline-specific load. The fabrication tolerances are included as constraints on the thicknesses for the different layers and on the external blade geometry.

3.4 Fabrication Process Tailoring - The simulator shown in Figure 5 was used for tailoring the composite fabrication process (Figure 6) for maximum in-plane loads (Figure 7) - ref. 4. Though, as a result of the fabrication process tailoring, the tensile load did not change, the pressure consolidation time was reduced by at least 30 percent. And, a processing history emerged to increase the compressive strength by about 50 percent.

3.5 System simulator - The simulation methods for discipline-specific and/or component-specific tasks are integrated to simulate entire systems. These

simulators are next to the last steps to develop computational simulators for concurrent Engineering. One such simulator is implied in Figure 8 (ref. 5). The next level of simulation which is that for the vehicle is shown in Figure 9.

4. SIMULATORS FOR CONCURRENT ACCOUNTING OF MULTI-DISCIPLINE UNCERTAINTIES

An important part of the engineering process is an accurate assessment of system's reliability and risk, most effectively simulated via probabilistic methods accounting for the uncertainties at various stages of the system development process. In absence of methods to treat these uncertainties, traditional approaches rely on a lump-sum safety factor, resulting in wasteful and inefficient overdesigns with increased costs. A methodology is under development where the uncertainties in load, structure, and material can be represented probabilistically. The corresponding uncertainties in the structural response can be quantified which can be subsequently used to assess component/system reliability and risk. The essence of the method is schematically illustrated in Figure 9 (ref. 6).

4.1 Damage Probability and Total Cost Simulator - Typical results, showing the probability of damage initiation risk and total cost vs. fatigue cycles, for an SSME blade are shown in Figure 10. This approach can also be used to assess improvements in material processing versus probability of failure and cost as is shown in Figure 11.

4.2 Benefits of Probabilistic Simulators - Accounting for uncertainties benefits the system development process by: (1) minimizing the amount of testing required for qualification and certification, (2) providing information on fabrication parameters which have negligible influence on system performance and reliability leading to relaxing of fabrication tolerances for these parameters resulting in cost savings, (3) relaxing material acceptance criteria in situations where certain material characteristic are insignificant to product reliability, (4) avoiding the need for unnecessarily high safety factor penalty in the system design, (5) providing a quantifiable means for defining the chances of product survivability in real-life service environments, and (6) bypassing the

presently emerging concept of fuzzy theory application to product design - since quantification of uncertainties inherently defines the acceptable product performance range which fuzzy theory is supposed to determine by the use of a subjectively determined quality function. This function can be readily represented by a suitable segment of the cumulative probability distribution function. The methodology readiness to account for uncertainties, reliability and risk is sufficiently mature to be incorporated in computational simulation methods for concurrent engineering or component assemblies and even vehicles.

Collectively, these specific examples demonstrate that substantial infrastructure is available and evolving that is essential to computationally simulate concurrent engineering for aerospace propulsion components accounting for uncertainties in respective variables.

5. AN EMERGING PLAN

An emerging plan is described as "integrate software packages for the computational probabilistic simulation of multi-disciplinary procedures through which propulsion systems are developed (conceived, designed, fabricated, verified, certified), installed, and operated. The plan is shown in Figure 12 with multi-discipline facets at the top, concurrent engineering computational probabilistic simulation at the center, and simulated system evolution at the bottom. This software system will consist of (1) work stations with discipline-specific modules, dedicated expert systems and local databases, (2) a central executive module with a global database and with communication links for concurrent interaction with multi-discipline work stations, (3) unsupervised learning neural nets, (4) adaptive methods for condensing and incorporating information as the system evolves, (5) zooming methods, (6) graphic displays, and (7) computer-generated files for computer-controlled fabrication machines. Also, the appropriate computer hardware needs to be available and configured for specific implementations.

6. CONCLUDING REMARKS

This paper briefly describes what is the state-of-the-art of the concurrent engineering process in terms of its necessity, interpretation, and implementation for the system development process. An infrastructure of the methodology/technology readiness

for the probabilistic concurrent engineering process is discussed. That infrastructure includes demonstrative examples for materials/fabrication/structural response/tailoring of propulsion structures via integrated/coupled multi-discipline and system simulators, while concurrently accounting for multi-disciplinary uncertainties. The results of these examples clearly demonstrates that the concurrent engineering process must be and can be computationally simulated and is timely. Finally, an emerging plan for computationally simulating the concurrent engineering process is described.

7. REFERENCES

1. Brown, K.W., Pratt, T.K. and Chamis, C.C: "Structural Tailoring of Engine Blades", AIAA/ASME/AHS, 24th Structures, Structural Dynamics and Materials Conference, 1983.
2. Brown, K., "Structural Tailoring of Advanced Turboprops (STAT), United Technologies Corp., P&W, 1988.
3. Singhal, S. N. and Chamis, C. C., "Concurrent Engineering Can Be Computationally Simulated", Proceedings of the TMS Symposium on Concurrent Engineering Approach to Materials Processing, Chicago, IL, Nov. 1-5, 1992, pp. 323-342.
4. Morel, M., Saravanos, D. A., and Chamis, C. C: "Concurrent Micromechanical Tailoring and Fabrication Process Optimization for Metal-Matrix Composites", NASA TM 103670, November 1990.
5. Chamis, C. C: "Computational Structural Mechanics for Engine Structures", NASA TM 102119, 1989.
6. Chamis, C. C. and Murthy, P. L. N: "Probabilistic Composite Analysis", Preprint for First NASA Advanced Composite Technology Conference, October 30-November 1, 1990.

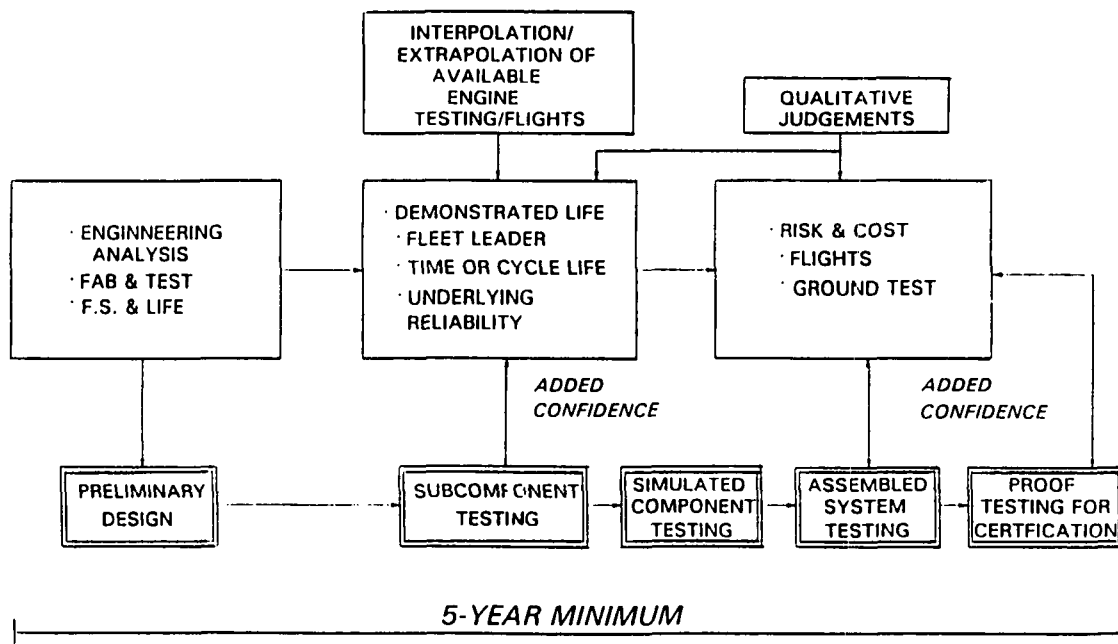
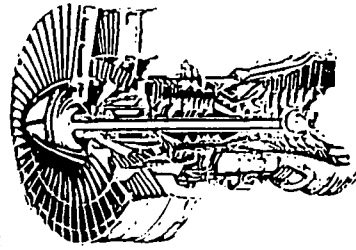
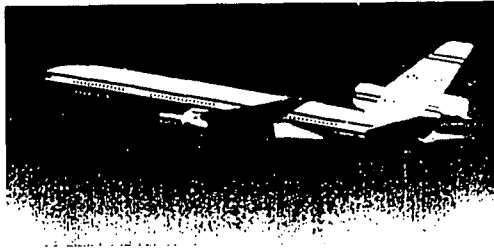

Figure 1 - Current development approach for liquid rocket propulsion

STAEBL - - STRUCTURAL TAILORING OF ENGINE BLADES



CURRENT DESIGN PROCEDURES

- WEIGHT 17 LB
- ROI 3.0%
- PROF. MANYEARS 52 WEEKS

STAEBL DERIVED DESIGN

- WEIGHT 16 LB
- ROI 3.3%
- PROF. MANYEARS 1 WEEK

Figure 2 - Structural tailoring of engine blades

STAT - - STRUCTURAL TAILORING OF TURBOPROP BLADES

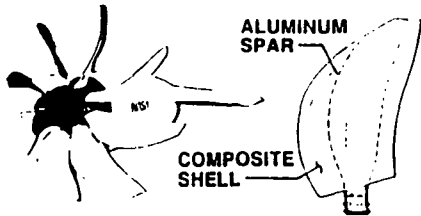

BLADE INTERNAL STRUCTURE

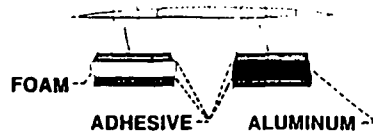

TURBOPROP STAGE AND PROPELLER

MULTI-DISCIPLINARY ANALYSIS MODULES

- ADS OPTIMIZER
- BLADE MODEL GENERATION
- AERODYNAMIC ANALYSIS
- ACOUSTIC ANALYSIS
- STRESS AND VIBRATIONS ANALYSIS
- FLUTTER ANALYSIS
- 1 P FORCED REPOSE

TYPICAL ANALYSIS RESULTS

	<u>INITIAL</u>	<u>FINAL</u>
EFFICIENCY, %	82.86	83.17
NEAR FIELD NOISE, DB	143.8	137.3
WEIGHT, LB	41.1	41.2
DOC	-0.853	-4.201

Figure 3 - Structural tailoring of turbo prop blades

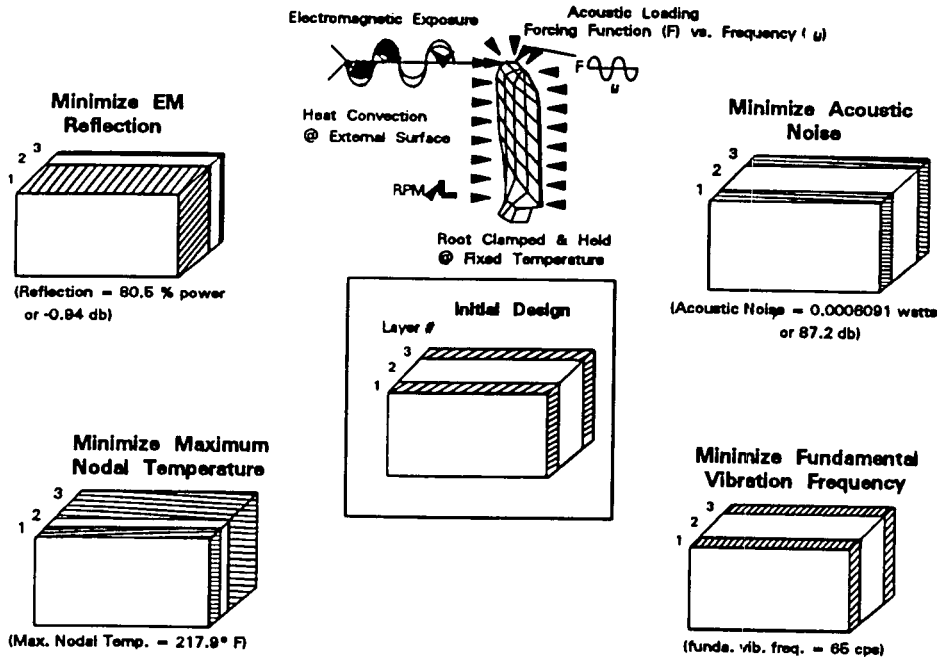

Figure 4 - Fan blade laminate configuration for multi-disciplinary tailoring

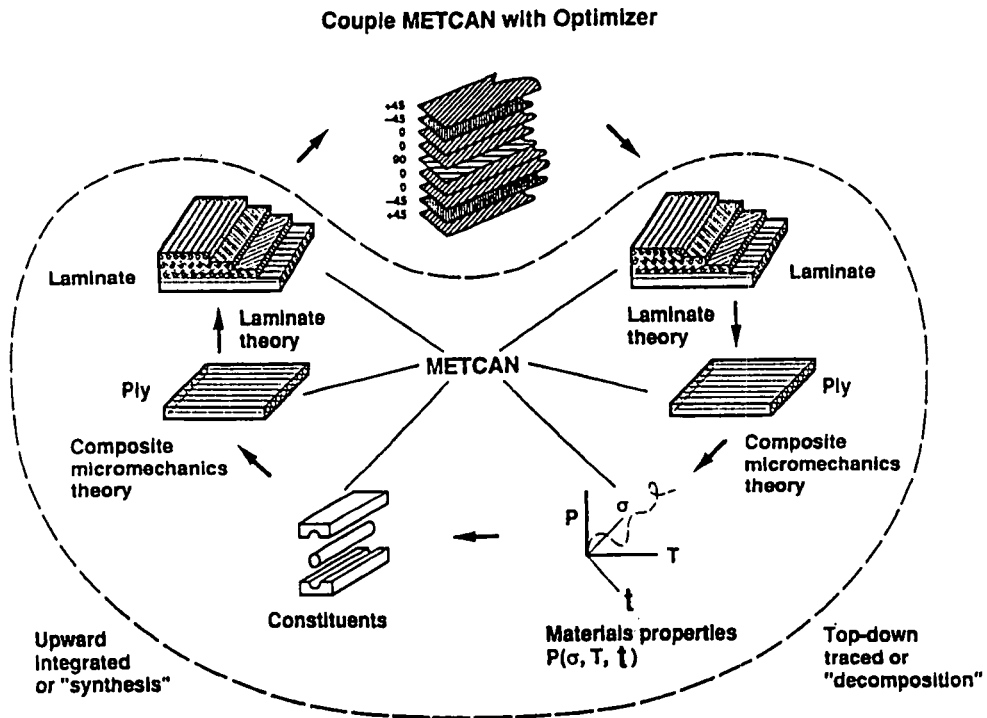

Figure 5 - Metal Matrix Laminate Tailoring (MMLT)

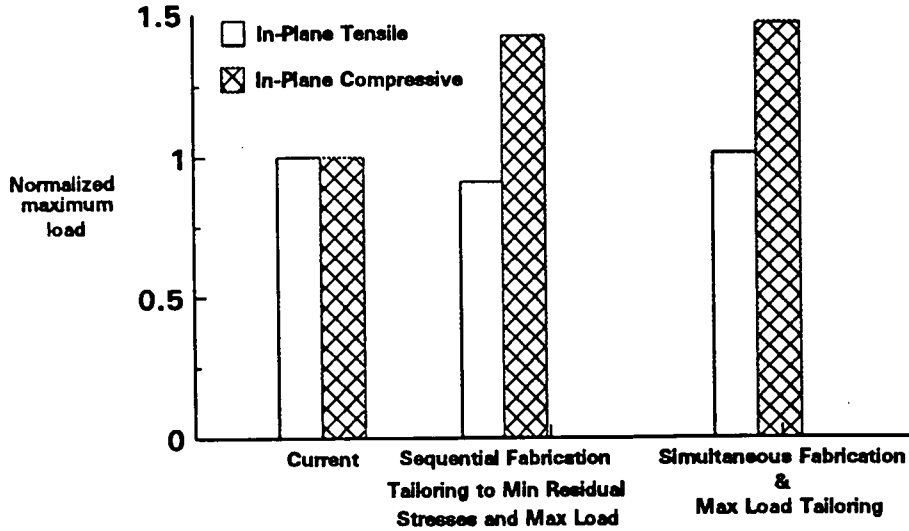

Figure 6 - Fabrication Process Tailoring Influence on the Maximum In-Service Load for P100/Copper [0/90]₃ at 316°C

Tailored Fabrication Process for [0/90]₃ Graphite/Copper by Different Objectives

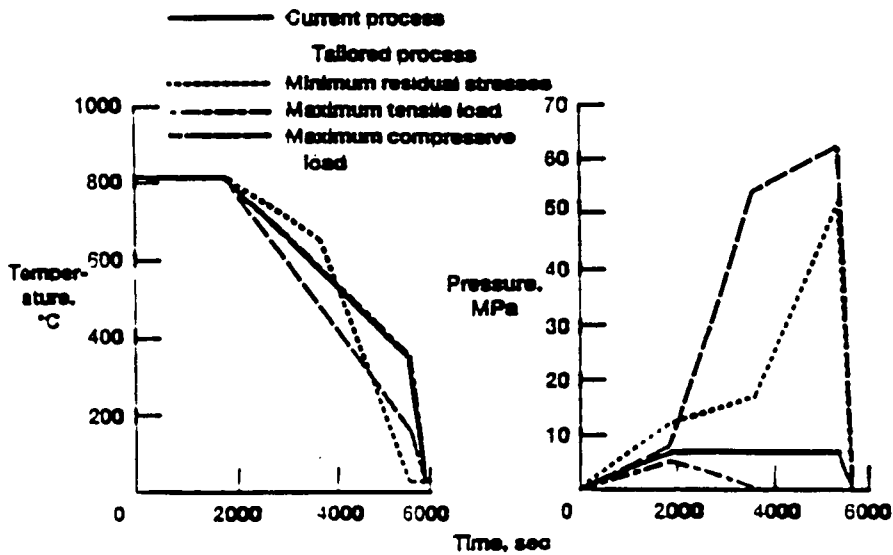

Figure 7 - Tailored Fabrication Process for [0/90]₃ Graphite/Copper by Different Objectives

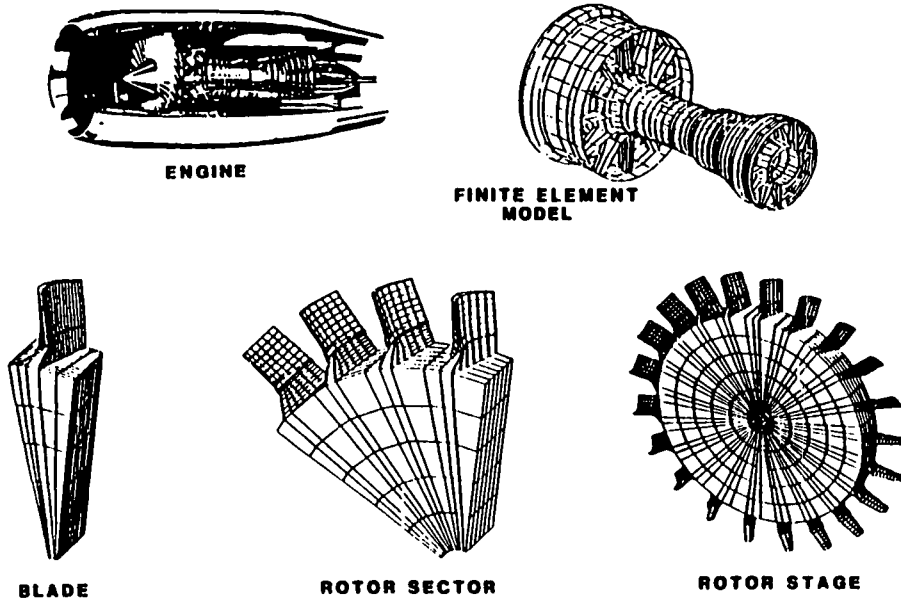

Figure 8 - Engine Structures Computational Simulator (ESCS)

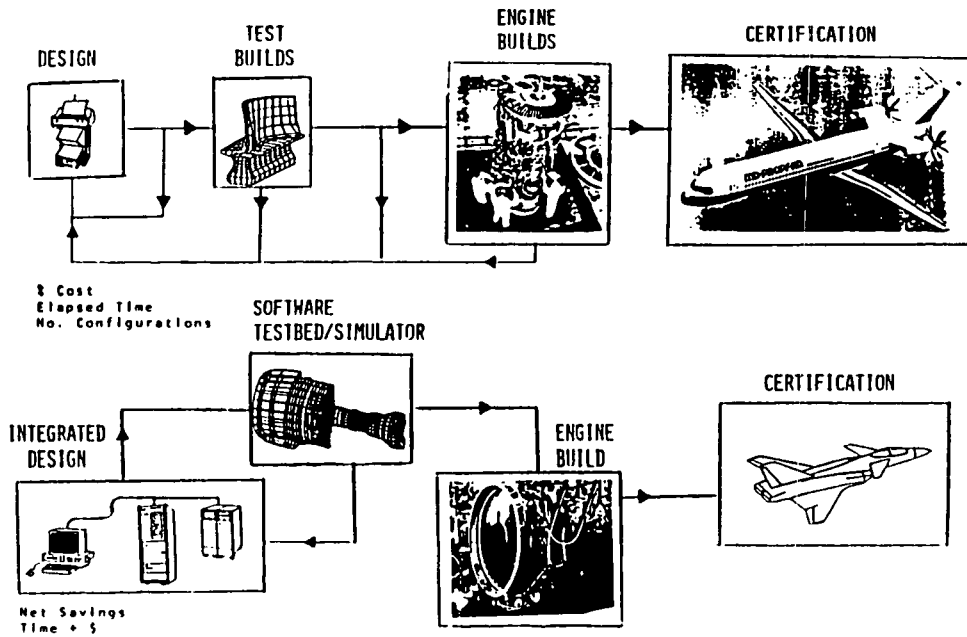

Figure 9 - Parallel between concurrent development and computational simulation methods

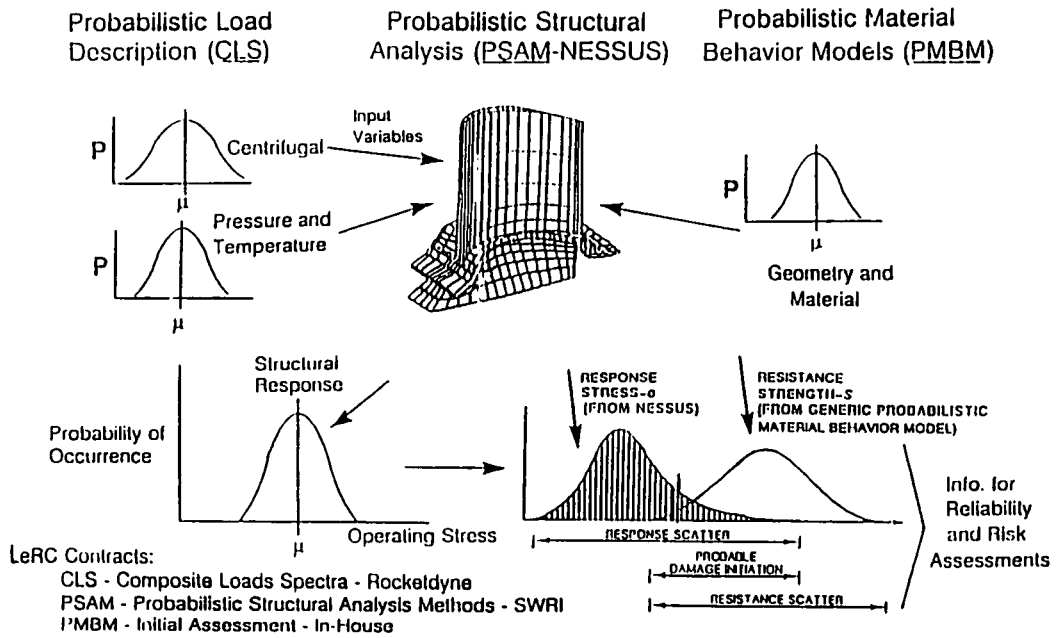

Figure 10 - Probabilistic Simulation of Component Reliability

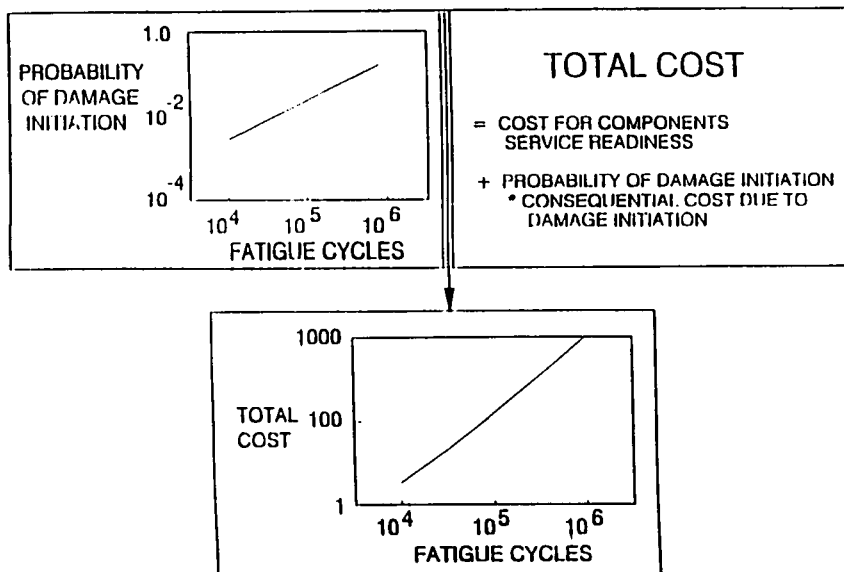

Figure 11 - Probabilistic Risk-Costassessment

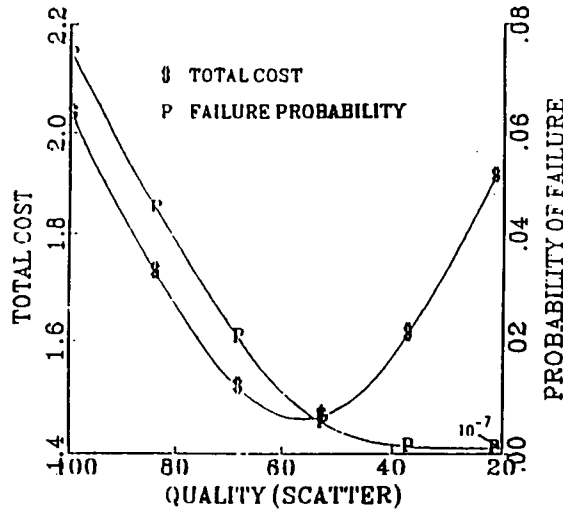

Figure 12 - Total cost for improving structural reliability quantified in terms of quality control

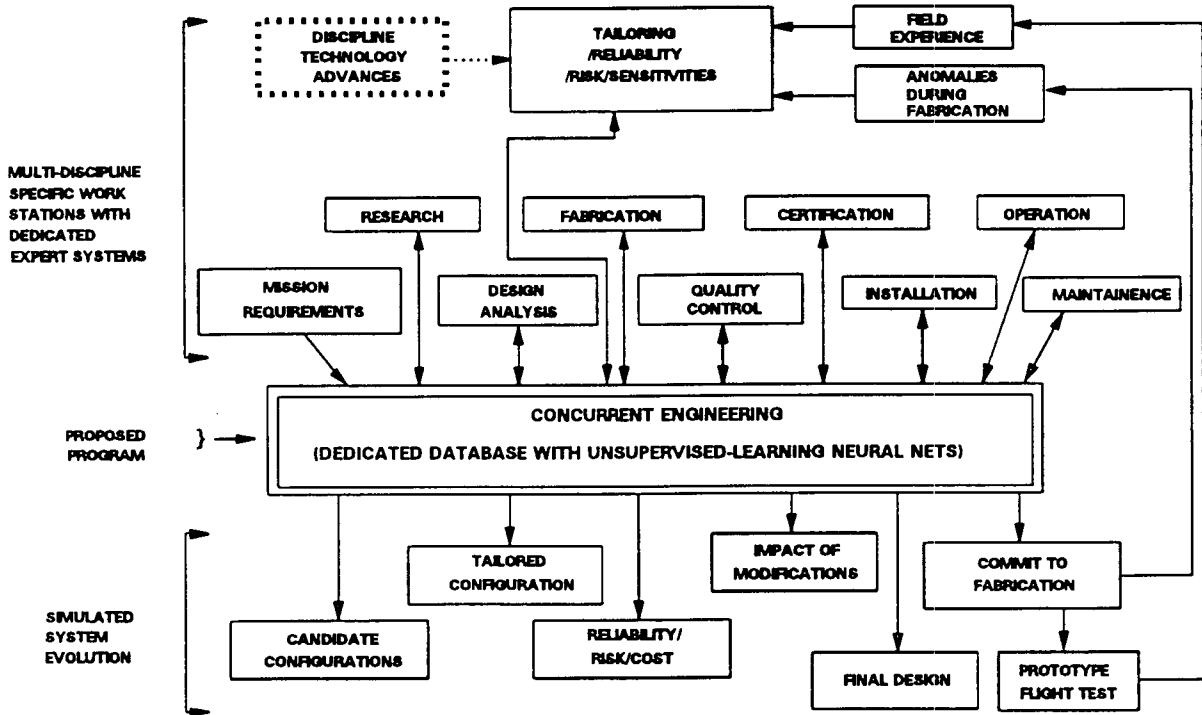

Figure 13 - Proposed plan for computational simulation of concurrent engineering

FRAMEWORKS FOR INTEGRATED AIRFRAME DESIGN

by

A.L. Shaw
Head of CAE and Technical Computing
British Aerospace Defence — Military Aircraft Division
Warton Aerodrome
Preston
Lancashire PR4 1AX
United Kingdom

1. Introduction

British Aerospace is Britain's largest Manufacturing Group. Products cover Defence Systems, Commercial Aircraft, Cars, Civil Engineering, Property Development, Construction and Project Management.

BAe Defence is the largest defence company in Europe with a turnover of £4.2 billion. Exports account for over 70% of sales. Military Aircraft Division is an important part of BAe Defence with major projects ongoing centred around HAWK, HARRIER, TORNADO and the European Fighter Aircraft EFA.

2. Paperless Aircraft

The 'Paperless Aircraft' project was initiated within Military Aircraft Division during the 1980's with the major aims of reducing costs, improving quality and compressing the aircraft development lifecycle.

In order to develop an appropriate technology base a thorough understanding of the design process had to be assimilated. This was achieved by developing a series of frameworks for integrated airframe design inclusive of all disciplines involved in the product definition lifecycle.

The project spreads across many areas and will ultimately run through from Electronic Contract and Specification, Concept Design, Baseline Standard Aircraft Definition to Automated Detail Design through to a 3D digital product model, Aircraft manufacture and in service support.

Theoretical Analysis, Testing, Flight Test and Certification are all becoming dependent on Computer software and visualisation of results is much improved particularly in terms of comparison of data. This is enabling engineers to be much more confident in their designs.

The Management of data in a complex environment is also an issue covering the transition from 2D drawing to 3D model, upstream technical areas and downstream Production Engineering through to manufacturing. Systems are being developed to cover these activities leading to the establishment of a CITIS (Customer Integrated Technical Information Service) covering both Technical and Business Data.

CITIS is part of the MoD/DoD requirement for implementation of CALS (Computer Aided Acquisition and Logistics Support) which is a business strategy to introduce Concurrent Engineering, establish international standards and develop integrated logistics support systems based on a digital definition of the product.

The transition to a 'Paperless' environment is a key initiative being taken on by the worlds leading Aerospace Companies as a new way of doing business in the 1990's.

For the future MAD intends to continue implementation of 'Paperless' concepts with emphasis on the introduction of Concurrent Engineering for its major projects particularly EFA. It is putting into place the necessary organisation changes and investment in technology to achieve effective generation of the product models and management of data across the multi-function teams.

3. Concurrent Engineering

Concurrent Engineering is being implemented as part of the Company's business plan to reshape the organisation and reduce the product lifecycle. The tools developed for the electronic 'Paperless' environment provide the enabling technology to make this happen.

Concurrent Engineering is a business strategy to re-organise people into integrated multi-function project teams utilizing Computer Aided Engineering tools as the enabling technology. The objective is to reduce timescales and improve quality by moving from a sequential series of operations to a more product focused environment which will allow simultaneous activities to be properly co-ordinated.

During the late 1980's two projects have provided a basis for MAD's implementation of CE. These are the 'Hawk' competitiveness programme and the 'Paperless Aircraft' project. Both these activities concentrate on the requirements for CE with emphasis on 'Organisation' and 'Technology'.

The Hawk project aimed at a reduction in cycle time for pre-production activities and a better design definition by involvement of all functions operating as a team from the outset. This approach was adopted on the T45 GosHawk wing project and demonstrated both reduced 'makespan' and significantly less change in manufacture.

Building onto this experience is the development work on the 'Paperless Aircraft' utilizing 3D solids to define product models which enable clear visualisation to be achieved at an earlier stage in the design.

These product models provide centralised databases for major projects and are being used for the creation of digital mock-ups for EFA, Harrier and Hawk.

The new techniques have been used to good effect on each of these projects. On EFA the Wing and centre fuselage fuel volumes were created as solid models and the resultant wing volume was within 2% of the figure obtained by filling the actual wing with fuel.

For the Harrier the pitch control system was modelled together with surrounding structure. Then using Kinematics a fully working mechanism was defined thus enabling a successful audit to be achieved prior to commitment for manufacture.

In addition to the above in August 1991 a Concurrent Engineering team was set up for the EFA single seat aircraft front fuselage to fit the full avionic suite in the radar bay.

The major areas of re-design were modelled and completed in March 1992 and have resulted in a clearer definition of structural and systems assembly requirements in a highly complex area of the airframe.

This has had a significant impact on the planning process providing a much better insight into understanding the downstream activities necessary to achieve build at an earlier stage in the design. To date detail manufacture necessary for the fitting of the avionics boxes which include machined items, flat and formed parts and pipes have all been made without the need for any design changes.

The whole of the 'radar bay' structure as defined by the 3D solid model has been built with only a small number of engineering changes due mainly to assembly mismatches.

MAD is now turning its attention to the training required for Concurrent Engineering centred around the need to develop broader skill based 'Design Engineers' rather than single disciplines. These engineers will be supported by specialists who will have in depth functional based skills together with enabling technology 'tool set' expertise.

4. Product Definition

Current activities are leading towards CALS compliance with the adoption of STEP ISO-10303 when available.

For new design, product definition is developed on CATIA as a 3D master model which also serves on some projects as an 'Electronic Mock-Up'.

Electrical wiring definition is achieved via 'in house' developed systems:-

- BCAWD - BAe Computer Aided Wiring Diagram
- BCAPE - BAe Computer Aided production Electrical.

These systems cover schematic wiring diagrams and wire data respectively and are compatible with 'European' standards.

Integration of engineering and technical data is to be achieved by development of a new Data Management System CAEIMS - CAE Information Management Service. This will eventually form the infrastructure necessary to transform data from different systems into a CITIS environment.

Definition of Product Structure is via a number of mainframe systems which are part of the company 'Overall Business Architecture'.

Essentially 'Bills of Material' are produced on the Design Product Definition System - DPDS. Configuration Control is achieved via CMS - Change Management System. Both systems are compatible with European Standards in terms of the AECMA ABC guidelines.

There is a proposal to bring this standard into line with STEP and this is being considered by the AECMA Technical Industrial Commission.

The Procurement and Management of Aircraft Ground Equipment is controlled by another 'in-house' developed system PAMAGE. This is used by Partner companies, MoD and Rolls-Royce. It is the intention to make this system compliant with MIL-STD-1840A for automated data interchange.

For the future 'Image Distribution' is being considered as a replacement for microfilms and a pilot project is in progress on the HAWK. Documentation is also being reviewed on HARRIER to determine the feasibility of converting Stress/Aero calculations to electronic storage.

There is considerable customer interest in this area and provided this continues compliance with relevant CALS standards will be achieved.

5. Data Management

The main elements required to control data will be covered by the development of a new system. CAEIMS - CAE Information Management Service.

This will provide a 'Kernel' for marshalling data from the Company's data bases to the appropriate usage point 'in-house' and to external customers/suppliers/sub-contractors via a CITIS gateway.

The principles being addressed are:-

- o Data configuration control
- o Electronic approval/Release Cycle
- o Visibility of data associativity and audit trails
- o Data availability within access control parameters
- o Data flow control and automated interchange

For the exchange of data with external customers development is aiming towards CITIS which will provide standard communication to/from the customer and data conversion to CALS Standards/Communication protocols.

Architecture and user access are being considered together with issues yet to be resolved relevant to the commercial implications of CITIS and development of the final specification.

6. Conclusion

The development of the integrated airframe design process has progressed naturally by proving its worth relevant to business need together with being able to respond rapidly to more and more demanding project requirements.

As the Aerospace business evolves the need for highly efficient design, analysis, optimisation and rapid prototyping techniques is becoming even more critical to achieving the competitive edge necessary to operate successfully in world markets.

MAD has faced this challenge and intends to maintain and improve its position as one of the world leaders in the field of Military Aircraft design.

INTRODUCTION

- **BAe Defence**
- **Paperless Aircraft**
- **Concurrent Engineering**
- **Product Definition**
- **Data Management & Exchange**

Figure 1

DEFENCE

- BAe Defence is the largest defence company in Europe
- Military Aircraft Division is an important part of BAe Defence with major export contracts
- Principal products are HAWK, HARRIER, TORNADO and the new European Fighter Aircraft



Figure 2

PAPERLESS AIRCRAFT

- Initiated in the 1980's

Business Objectives

- Reduce costs
- Improve quality
- Compress the aircraft development lifecycle

A downward-pointing arrow is positioned above a black rectangular box with a white border. Inside the box, the text 'Improve Business Performance' is on the top line and 'Current and Future' is on the bottom line, both in white, bold, sans-serif font.

Figure 3

PAPERLESS AIRCRAFT

Technology

- Establish a 'Digital Master Product Model'
- Develop integrated systems
- Provide effective data management
- Implement Concurrent Engineering

A downward-pointing arrow is positioned above a black rectangular box with a white border. Inside the box, the text 'Integrated Airframe Design' is written in white, bold, sans-serif font.

Figure 4

DESIGN PROCESS FRAMEWORK

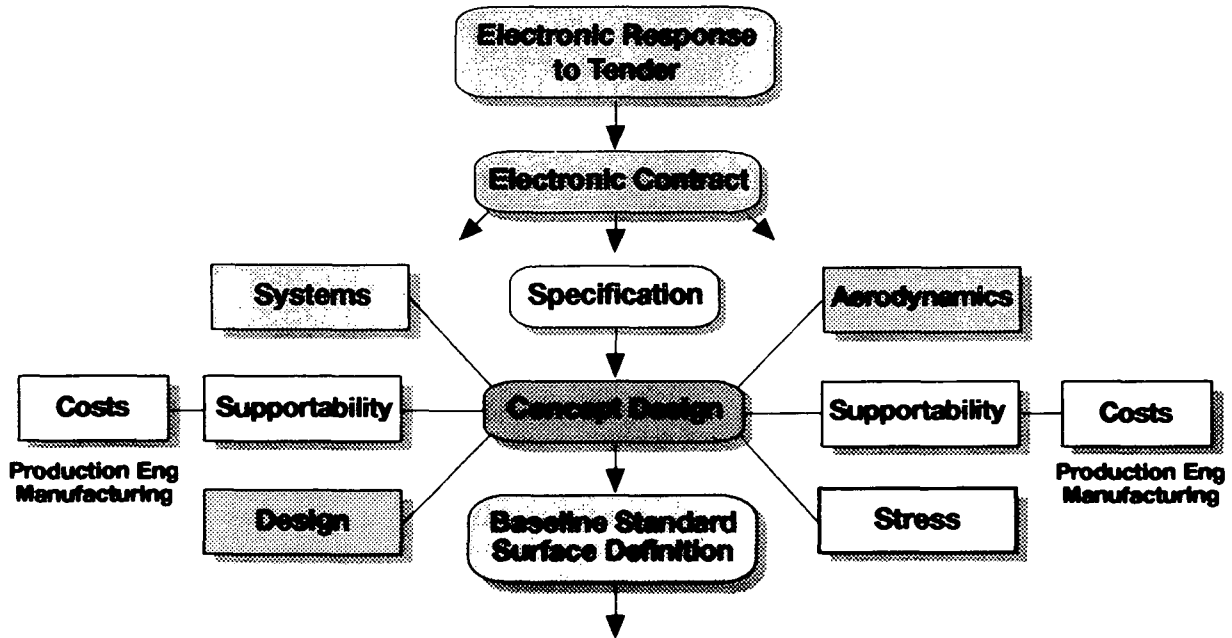

Figure 5

DESIGN PROCESS FRAMEWORK

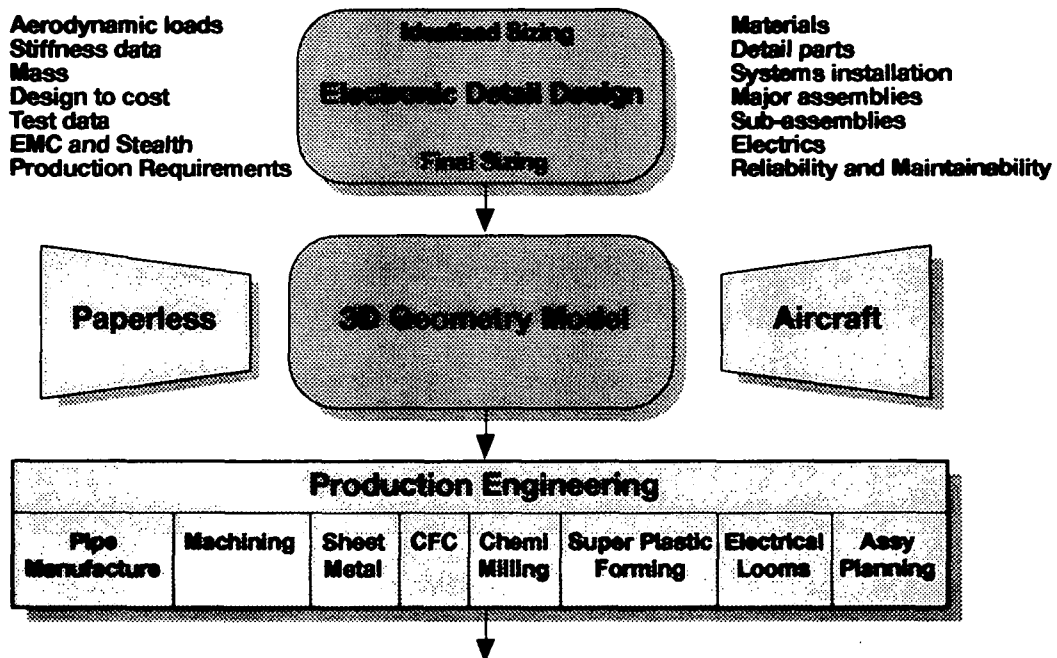

Figure 6

DESIGN PROCESS FRAMEWORK

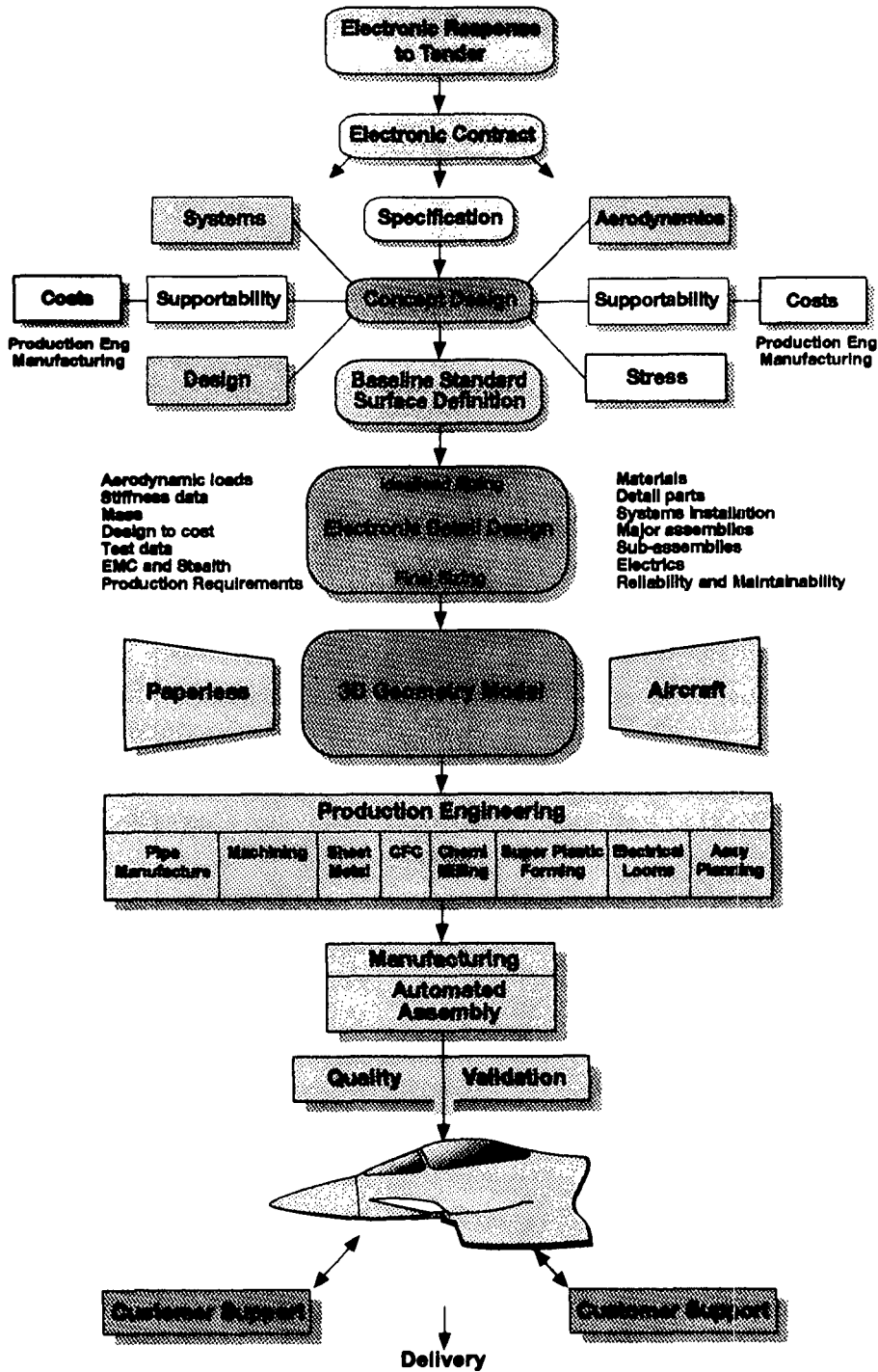

Figure 7

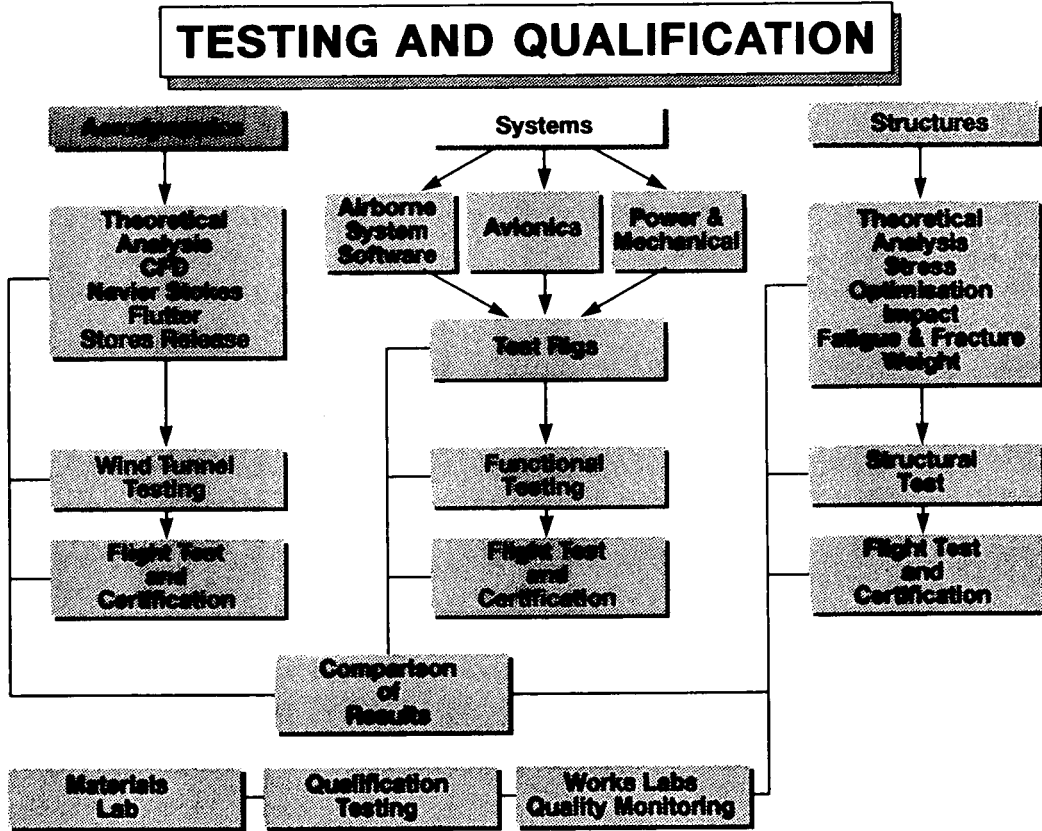

Figure 8

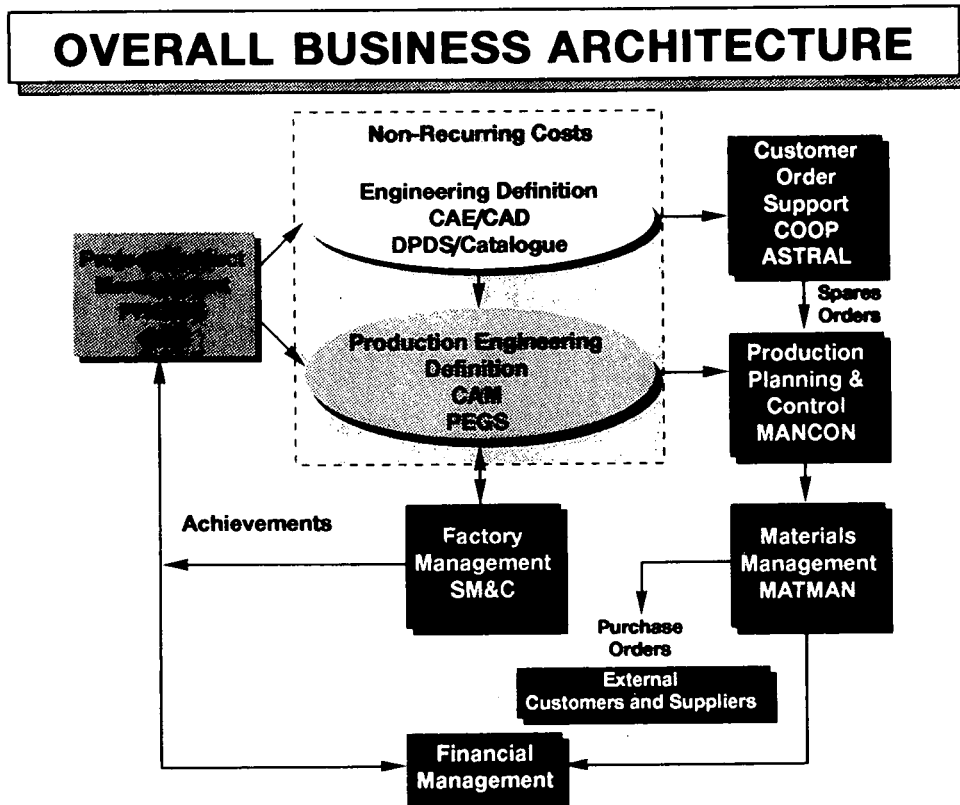

Figure 9



Figure 10

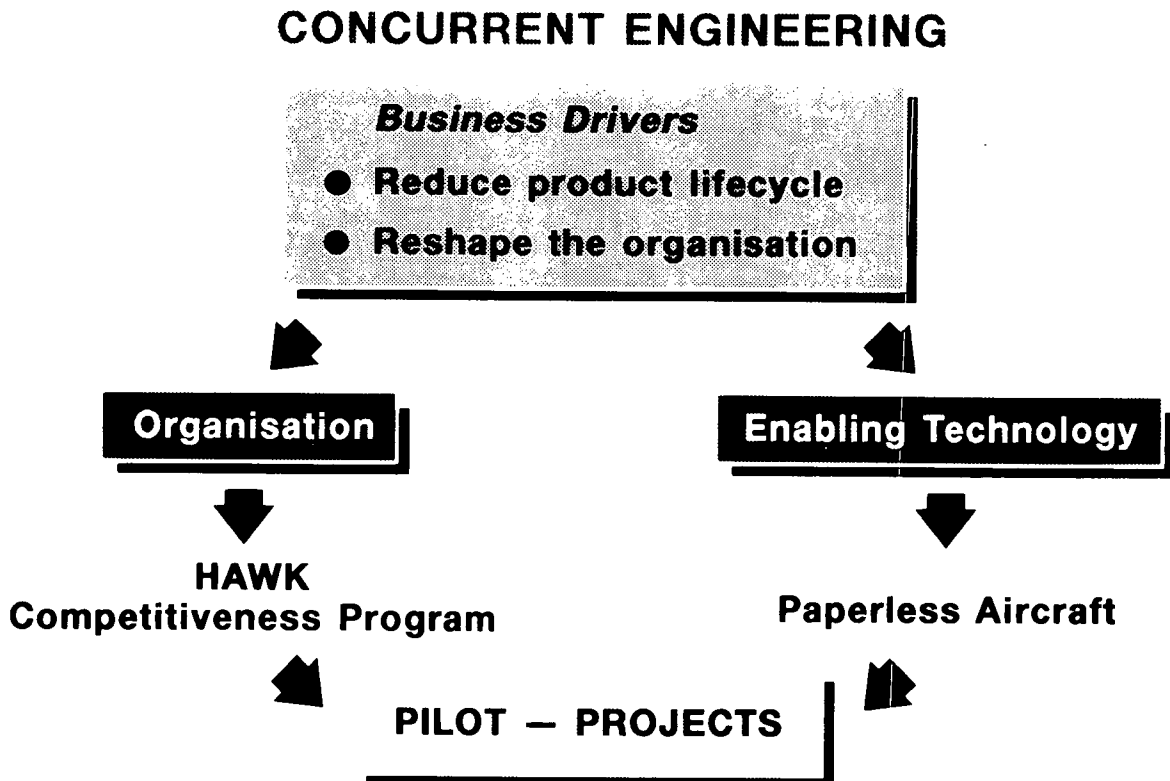

Figure 11

CONCURRENT ENGINEERING

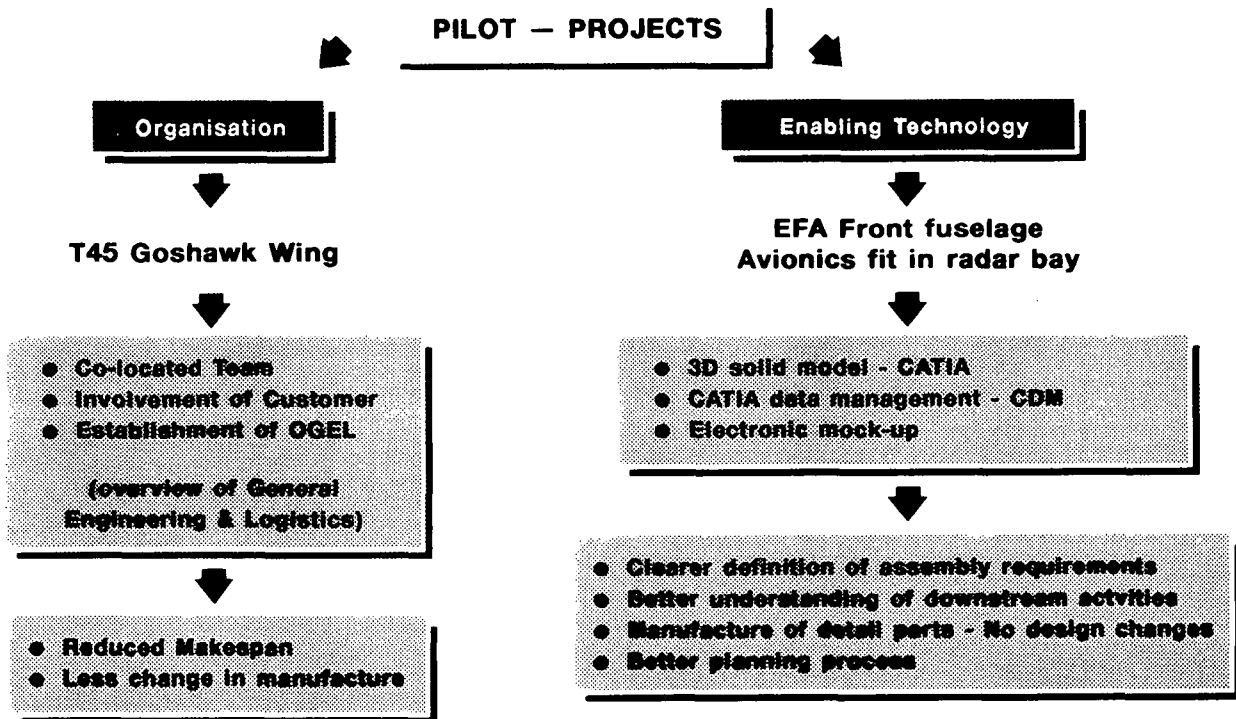

Figure 12

CONCURRENT ENGINEERING

Lessons Learned

- Need to re-profile investment
- 'Up Front' design requires more time
- Co-locate the team or provide *virtual* co-location
- Lifecycles must be synchronised — eg. SYSTEMS/AIRFRAME
- Data management is essential

For the Future

- MAD will introduce CE on a wider scale
- Organisation is being put into place
- Enabling technology investment plans are being revised to meet the new business environment

Figure 13

PRODUCT DEFINITION

Airframe Design

- **Aerodynamics** — CFD/Navier Stokes — Wind tunnel results
- **Structures** — PATRAN/NASTRAN — Structural test results
- **Design**
 - CATIA — 3D master model/electronic mock-up
 - Anvil — Mechanical CAD/CAM
 - BCAWD/BCAPE — Electrical CAD/CAM
 - DPDS — Product Structure/Bill of Material
 - CMS — Change Management

System Design

- **Software** — CORE/ICD/HOOD/ADA → IPSE
 - **Hardware** — Specifications — Test rig results
- } Simulation/ Analysis Models

Flight Test

- **Comparison of Results** — Airframe/Systems



Overall Business Architecture

Figure 14

PRODUCT DEFINITION

Current

- **Product Structure (DPDS)**
- **Change Management (CMS)**
- **Electrical CAD/CAM**
- **Mechanical CAD/CAM**

**European Standard
 AECMA ABC Guidelines**

IGES - MIL - D - 28000

Future



STEP — CALS STANDARD ISO 10303 / EN30303

Figure 15

PRODUCT DEFINITION

Future

Image Distribution

- Drawing Set (currently microfilmed)
- Documents (currently paper)

➤ Raster Graphics
MIL-R-28002

Ground Equipment

- PAMAGE (Process & Management of AGE)

➤ SGML
MIL-M-28001

Configuration Control

- Customer/Contractor/Supplier integration



Functional Design Build Standard
Customer Configuration Control System

➤ STEP
MIL-STD-1840A

Figure 16

DATA MANAGEMENT

- Development in progress of CAE IMS

CAE Information Management Service

- Will provide a 'Kernel' for marshalling data to and from company data bases
- External Customers/Suppliers/Sub-Contractors will access via a CITIS gateway
- CAE IMS will provide access control to engineering data
- Data conversion to CALS standards and communication protocols will be carried out on a project requirement basis

Figure 17

DATA MANAGEMENT

Important Issues

- Data configuration control
- Electronic approval/release cycle
- Visibility of data associativity and audit trails
- Data availability within access control parameters
- Data flow control and automated interchanges

Figure 18

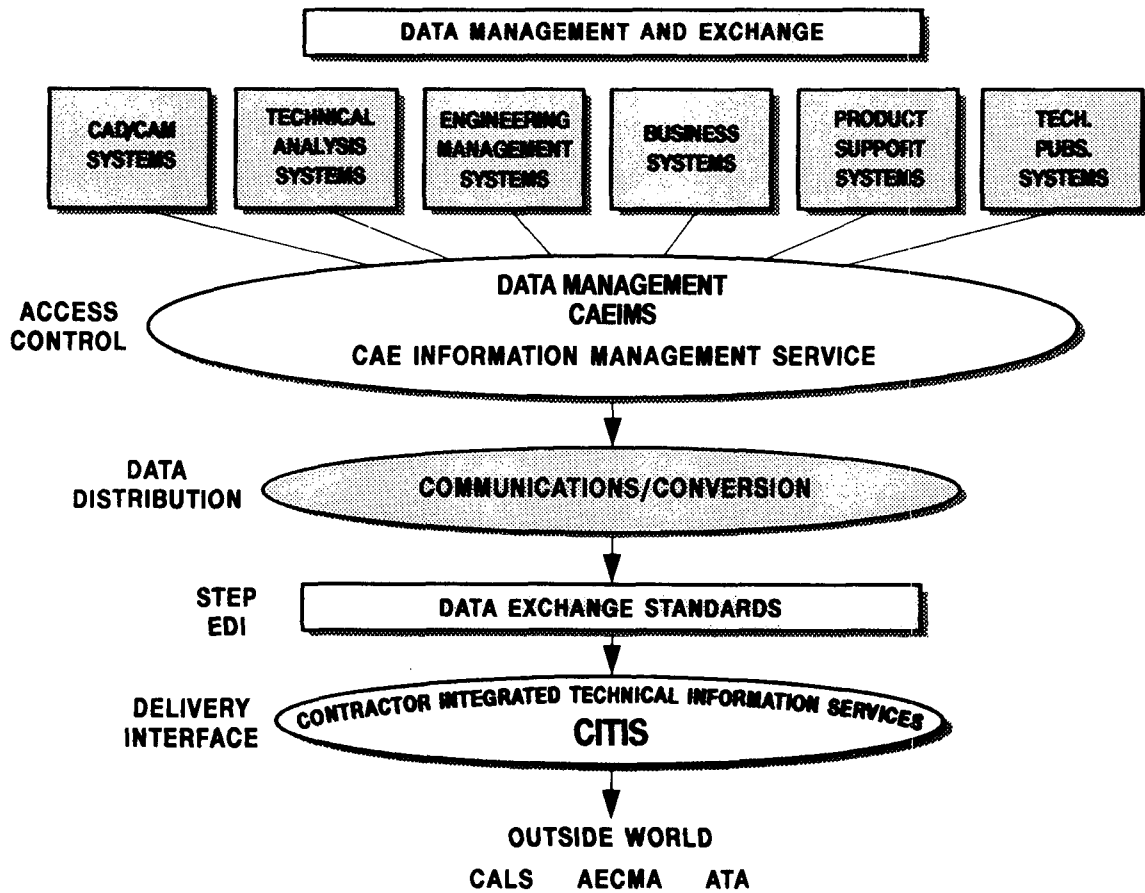

Figure 19

CONCLUSION

- Integrated Airframe Design developed to meet **Business Needs**
- Investment will continue for specific project requirements

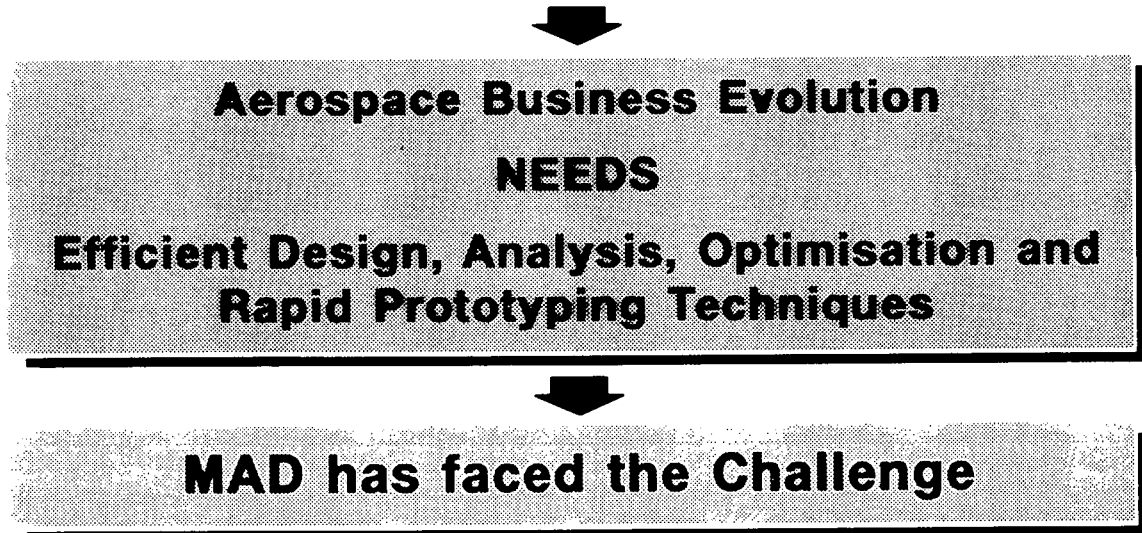

Figure 20



Figure 21

The Process Network in the Design and Manufacturing of Aircraft

J. Krammer
A. Rüttinger

Deutsche Aerospace AG
Military Aircraft
P.O.Box 801160, 8000 München 80
Germany

Summary

The paper presents in the first part some ideas for investigation and improvements of development processes. Typical processes are shown using the SADT-technique and a process flow diagram. In the second part a redesigned process chain for the design and manufacturing of complex composite parts is explained. Two examples show the functionality of the new developed constructive design model for this process.

1. Introduction

Present and future high performance aircraft designs will be characterized by increasing complexity which involves for example that the weight and the costs (e.g. development and life cycle costs) are dominated by non-structural parts such as systems for guidance, survey, flight control etc. with a huge amount of electrical lines. Another important fact is, that the customers, that means airforces and airlines, are not willing and able to pay any price for a product, which is indeed technological top, but the fly-away price and/or operating costs are too high. These points must lead to some changes of goals and strategies in aircraft developing companies, which have to be considered. Thus it is first necessary to identify the features which are essential for a successful marketing and development of a product (Fig. 1):

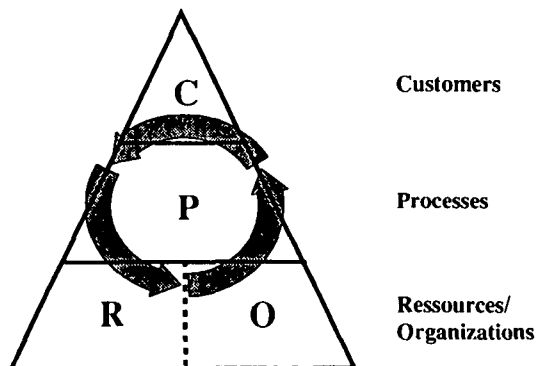

Fig. 1: Essential features for successful marketing and development of products

- contentment of customers (external as well as internal)
- optimized interdisciplinary processes (network of different process chains) with reduced cycle times and costs and adequate quality
- economic use of human and material resources (staff, machines, hardware and software tools)
- flexible organization models and methodologies.

The next step is to examine the existing situation and processes and to define priorities and goals for improvements (e.g. reduction of development time and/or costs by 20%). Very useful in this phase is benchmarking, that means realistic comparison of the processes with those of partners and competitors ("best in class").

After that a "redesign" or more effective a "rethink" (e.g. just-in time methodologies) of processes and methodologies must happen followed by a realistic implementation plan of the new ideas.

The further content of this paper is limited to process aspects and will suggest first a methodology how to model interdisciplinary aircraft development processes and the related product data.

With a special example the redesign of an existing sequential design and manufacturing process chain for complex composite skin structures into a highly parallelized and time reduced development process is shown.

2. The aircraft development process

Since a few years, at Deutsche Aerospace (DASA) aircraft engineering department some projects were started to improve the development processes. Although much of the product design has been automated by CAD/CAM and other tools and product and engineering data has become a great deal more accurate, the overall productivity of engineering has not much improved because the processes have not much changed.

During the last month, detailed investigation of existing processes and data flows have took place in order to find potentials for improvements like

- unnecessary iterations
- double activities
- breaks in data structures
- management of data and informations
- no value-added processes
- bureaucracy.

To identify the problems, different views on the product and on the process are necessary. For a complete product model a hierarchic decomposition of the aircraft structure (Fig. 2) must be done in order to know the interdependencies and transmissions of informations between the different parts and objects.

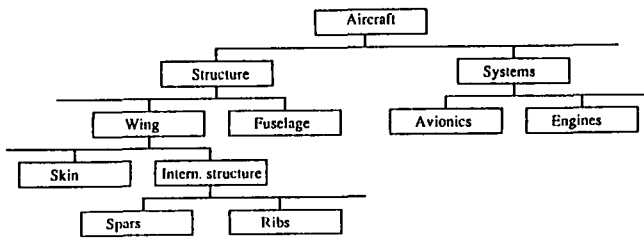

Fig. 2: Rough product structure of an aircraft

Directly connected to a certain part/object is its design, manufacturing and assembly process with the attached relevant data.

As a method for the functional modelling of complex processes the tool-supplied SADT/IDEF0-method (Structured Analysis and Design Technique) was used. In Fig. 3 two levels (Context and main activity diagram) of typical aircraft business processes are shown. (To get all necessary informations about the processes inputs, outputs, ressources and control parameters, a structured questionnaire has to be developed.)

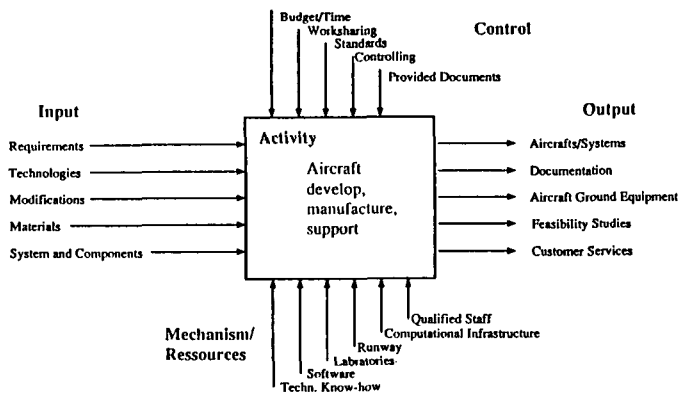

Fig.3a: Context diagram

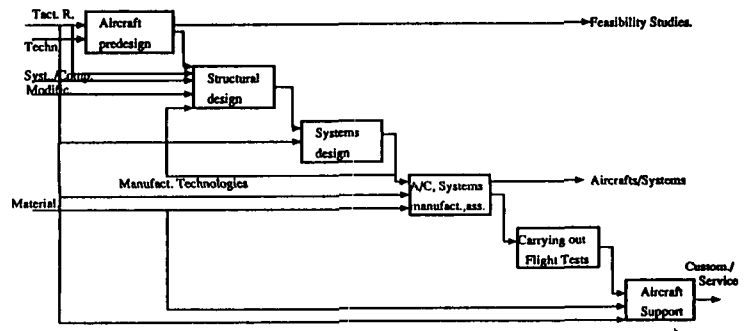

Fig. 3b: Main activity diagram

Starting with this IDEF0 or ARM-model (Application Reference Model) a data model (IDEF1 or AIM = Application Information Model) can be derived in the next step. With that a product model of parts or assembled structures or - in the future - of a complete aircraft can be developed. These models contain in a standardized format (e.g. STEP = Standard for the Exchange of Product Data) all relevant data and informations for the product development process and every participant of the process - from the first idea until to the recycling of the aircraft - can use those data with the tools which are necessary in the corresponding life cycle phase.

To include finally the process time in the investigations in order to identify potentials for parallelizing of activities, process flow diagrams (PERT-diagrams) and/or GANT diagrams can be used. An example of the X31-Wing predesign process is shown in Fig. 4.

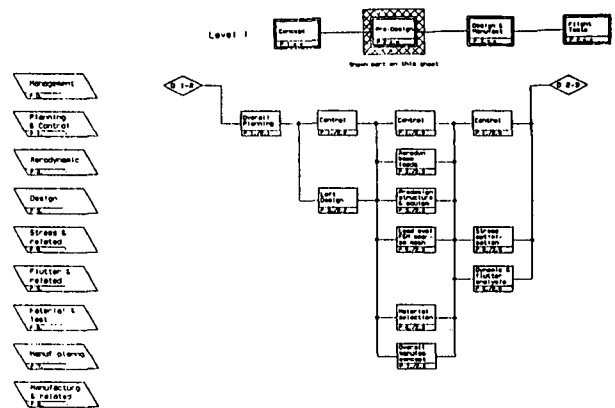

Fig. 4: Process flow diagram (pre design)

In the following chapters a redesigned process chain for the design and manufacturing of complex composite parts is explained. It is a realization of an integrated process that links simultaneously relevant design parameters and manufacturing informations and generates at the design level a part program that can directly be post-processed into NC-data for a tape application machine. As a common product data model the the dimensional geometric data (e.g. CATIA) are used [1,2].

3. Process chain for composite structures

In aircraft design, requirements concerning failure safety, vibration behaviour, aerodynamic and aeroelastic structural properties, stability (buckling), manufacturing etc. have to be considered in the development process. At the same time a minimal structural weight and low production costs should be achieved.

The system layout, i.e. the topology and the shape of the components, as well as the choice of material types and the material layout (e.g. ply distribution and fiber orientations of composites) have to be determined considering the multiple and extremely complex correlations mentioned above. Structural optimization methods are very useful in order to solve such design tasks much faster and much more efficient than it can be done by conventional solution concepts [3,4]. Additionally they make it possible to achieve technically and economically "optimal" designs.

Within an structural optimization process structural analysis methods, mathematical optimization algorithms as well as an optimization model are combined in a control loop to solve a design task [4,5]. The design task is formulated by the optimization model, which contains a design model describing the design freedoms and an evaluation model describing the objective function(s) and the constraints.

3.1 Control Loop of the Optimization Process

In order to deal with optimization problems in the structural design process, a procedure following the "Three-Columns-Concept" [4,5] seems most suitable. Following this concept, the solution procedure is divided into the "three columns":

- I) Structural model,
- II) Optimization model and
- III) Optimization algorithm

The structural design problem is mathematically described as follows:

General Nonlinear Problem (NLP)

$$\begin{array}{lll}
 \text{minimize} & f(x) & \text{(objective function)} \\
 \text{subject to} & g(x) \geq 0 & (m_g \text{ in-equality constraints}) \\
 & h(x) = 0 & (m_h \text{ equality constraints}) \\
 & x_1 \leq x \leq x_n & \text{(lower and upper bounds)} \\
 & & \text{for the design variables } x
 \end{array} \quad (1)$$

This problem formulation is carried out by the optimization model which, among others, is divided into a design- and an evaluation model. The design model defines the relationship between the structural variables and the design variables. Structural variables are physical parameters, e.g. cross sections, fiber orientations etc. the optimal values of which have to be determined, while the design variables represent the mathematical quantities which are processed by the optimization algorithm. By means of the evaluation model, it is defined which state quantity of the structure is to be minimized and which conditions or ultimate values are to be considered for the other state quantities. Thus, the optimization model is the mathematical description of the structural design task. For that reason, the optimization model is of special importance, since a truly optimal solution can only be achieved by completely and accurately defined design task which considers all

demands on the structure. The structural model supplies a mathematical description of the physical behaviour of the structure using appropriate state variables (e.g. aerodynamic pressure, stresses; stains, eigenvalues and eigenmodes, aeroelastic efficiencies, flutter speeds, shear strains of prepreg-tapes etc.) which depend on the structural variables (shape, cross-sections, ply distribution, prepreg-courses etc.) For complex systems the structural model includes different analyses models and -procedures (e.g. aerodynamic panel model, finite-element model, manufacturing model etc.).

An optimization algorithm is a mathematical procedure for solving the problem defined by equation (1). With structural optimization problems there usually is a nonlinear relationship between the behaviour functions (objective and constraint functions) and the design variables. Because of this nonlinearity, the problem (1) cannot be solved explicitly but only by using an iterative, numerical process. For that purpose, several optimization algorithms with different solution strategies have been developed during the last decades. Experience shows that the efficiency and robustness of these algorithms often depend on the given problem. Therefore, it is advantageous to have more than one algorithm available to be able to choose the one which is most suitable for a given problem.

Fig. 5 shows the interaction of the "three columns" in the optimization loop.

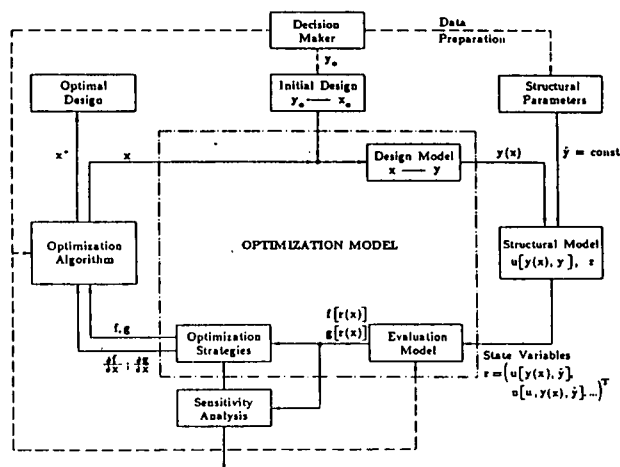

Fig. 5: Optimization loop

3.2 The constructive design model

The basic ideas of the constructive design models comprehend the geometrical modeling of the constructive layout and the assignment of design variables x_i to the constructive parameters z_j instead of the analysis variables of an analysis model. After determining the constructive parameters z_j from the design variables x_i the complete constructive layout can be determined. The analysis variables for the different analysis models then follow from the idealization of the constructive layout (Fig. 6 a, b).

Apart from the mathematical model of the constructive layout, this procedure requires unique, mathematically defined rules and procedures for determining the analysis variables for the various analysis models.

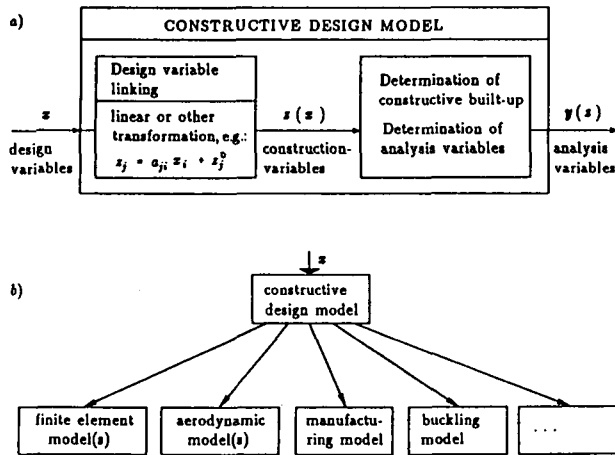

Fig. 6: a) Principal functions of a constructive design model
b) Determination of the analysis variables of different analysis models

Constructive design models have the following advantages:

- * direct and unique description of constructive layout:
 - > optimization results can be utilized directly,
 - > no falsification of the results by transforming FE-properties into a constructive layout,
 - > manufacturing and constructive constraints can be formulated mathematically and considered in the optimization,
 - > higher acceptance of structural optimization in practice.
- * design definition independent of the analysis model:
 - > multidisciplinary optimization with different analysis models can be carried out,
 - > analysis models can be changed in the optimization process, e.g. mesh-distortion for shape optimization or mesh-refinement in order to achieve sufficient analysis accuracy.

The disadvantage of constructive models is the higher programming effort necessary for a practical realization. In shape optimization, the use of constructive or geometrical design models is already usual. The following sections depict the special constructive design model formulations for the number of plies and the ply distribution as well as for the course of the prepreg-tapes in the single plies of laminated fiber composite structures.

3.3 General built-up of fiber composite aircraft structures

Aircraft components made of fiber composite materials are mainly subdivided into two classes.

1. Sandwich structures: a) full sandwich
 b) sandwich shells
2. Monolithic structures: a) stiffeners
 b) unstiffened shells
 c) stiffened shells

Stiffeners as well as shells consist of many laminated single plies. The single plies are manufactured by means of prefabricated prepreg-mats (fabrics) or tapes with discrete thicknesses (e.g. $t = 0,125$ or $0,25$ mm) The elasticity and strength properties of the laminate can thus essentially be designed by utilizing the following design freedoms:

1. Topological ply distribution on the surface (number and stacking sequence of plies placed one upon the other, arrangement and dimension of the single plies).
2. Fiber orientations in the single plies.

The realizable fiber orientations in the single plies depend on the applied prepreg type (fabrics or tapes) and on the manufacturing process. As far as prepreg-tapes are concerned, all fibers are orientated unidirectional (UD) so that the different fiber orientations in the laminate can be chosen freely. As described above, the possible arrangements are so manifold that they can only be fully utilized with the aid of structural optimization methods. This is the reason why in conventional design processes without structural optimization, the fiber orientations are usually restricted to four directions, which are arranged at constant steps of 45° (0/45/90/135). Subsequently "only" the number of plies and their distribution is determined according to the special requirements on the structure. By means of this, it is possible to meet all constraints. A minimal weight, however, is not obtained. Only if the single fiber orientations have been determined optimally, the constraints can be met with a minimal structural weight at the same time.

3.4 Integrated tape-laying process

In order to obtain a homogeneous covering, the prepreg-tapes should be applied on the structural surface without any gaps or overlaps. In aircraft construction, however, there are often double-curved application surfaces which are non developable. Because of the nondevelopability it would not be possible to prevent overlaps or gaps, if all the tapes would be applied along so-called "natural paths" (natural path = course of a tape which results from the tape-laying without any influence of external forces). This means that the tapes have to be applied along curved courses, in order to ensure a homogeneous covering. Until now, the prepreg application on such double-curved surfaces is carried out manually or in the case of a high number of pieces this process is partly automated by means of component specific tape-laying devices. In the manual application process only the laying direction of the first tape of the single layer (which is usually applied along a natural path) is usually prescribed by the laying direction at a reference point. The manufacturers then join all following tapes without gaps or overlaps by hand.

Normally the tape courses are only known approximately in the design process. In order to make the application process more efficient and reproducible, a tape-steering technology was developed during the last 3 years which allows a numerically controlled application of prepreg-tapes along curved courses on double-curved surfaces by a tape-laying machine (Fig. 7). [1,6]. If one merely would bend the tapes when applying them along curved courses, wrinkles would occur because of the different laying length of the fibers across the tape (Fig. 8). In order to prevent this, and to equalize the different laying lengths, the fibers are shifted in the tape-laying process (Fig. 8c, 9). The fiber shifting only causes shear strains in the prepreg-matrix whilst

the fiber strains are negligible.

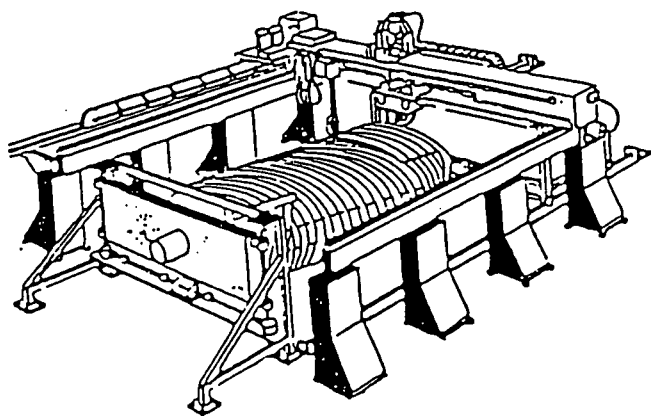

Fig. 7: Tape-laying machine

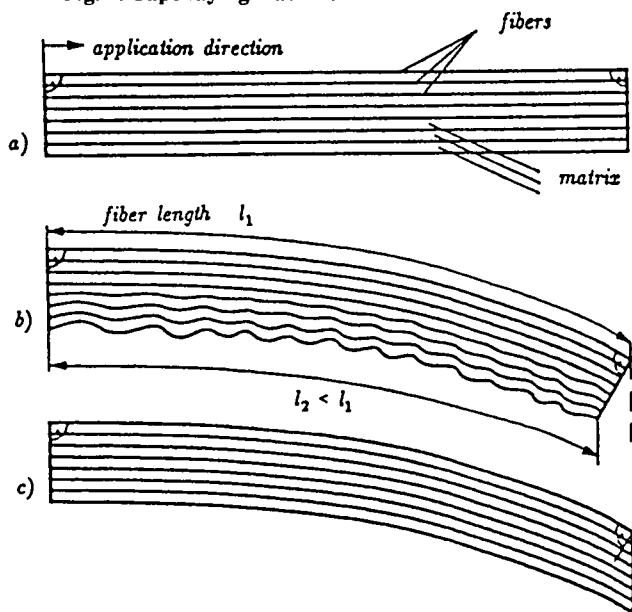

Fig. 8: a) Tape application along natural path
 b) Tape steering without fiber shifting => wrinkling
 c) Tape steering with fiber shifting => no wrinkling

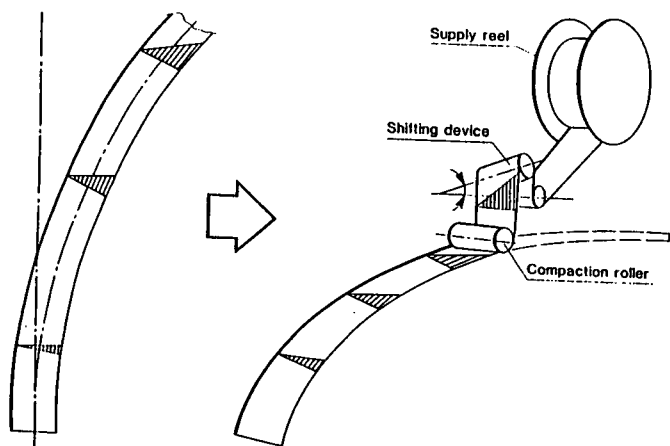

Fig. 9: Fiber shifting device for tape steering

The fiber shifting is only possible up to a certain limit because otherwise the resin matrix could be teared up. After the application, the shear stresses in the unhardened viscoplastic resin matrix relax completely [1].

Furthermore the curvature of the courses is limited by machine constraints. In addition to other technological demands, especially these curvature and shifting constraints are the most important manufacturing constraints which have to be considered in the design process.

Above all, the curved courses are utilized for a prepreg-application on double curved surfaces without gaps or overlaps. Depending on the surface curvature and on the laying direction there is still space for a course curvature which exceeds the range necessary for the surface adaptation. This design freedom can be utilized to fulfill the other constraints of the design task (static, dynamic, aeroelastic properties etc.) with less plies and by this, the structural weight can be minimized.

4. Constructive Design Models for FR-Composites

For the constructive description of the ply and prepreg distribution, a geometrical description of the application surface and its periphery is first of all required. Generally any parametric surface function $r_s(u,v)$ can be used for this purpose ($u, v =$ independent parameters). In order to describe arbitrary double-curved structural surfaces, sculptured surfaces consisting of several surface patches(8) are most suitable. The patches are usually described by biparametricpolynomials. Such sculptured surfaces are commonly used in commercial geometry modelers so that it is possible to use the surface data (coefficients of the polynomial functions) provided by such a geometry modeler [7].

4.1 Constructive design model of the ply distribution

In order to constructively describe the ply distribution, all single plies which have the same fiber orientation are combined in one ply group. Since not all plies of this group cover the total surface one obtains a step-like "ply group mountain", where the drop-off angles can be modelled and restricted to certain values to avoid delamination (Fig. 10a, b, c). This ply group mountain can approximately be described by an enveloping sculptured surface (Fig. 10b). For the mathematical description of this sculptured surface it seems recommendable for many reasons to use a Bezier-surface which is defined rangewise, and which consists of bicubic patches (Fig. 11):

$$t(\xi_1, \xi_2) = \left. \sum_{i=0}^3 \sum_{m=0}^3 f_i(\xi_1) f_m(\xi_2) b_{3i+1, 3j+m} \right\} \begin{matrix} i-1 \leq \xi_1 \leq i \\ j-1 \leq \xi_2 \leq j \end{matrix} \quad (2)$$

$$i = 1, \dots, n_1 \quad ; \quad j = 1, \dots, n_2$$

where t envelope of the layer group,
 ξ_1, ξ_2 independent parameters,
 f_i, f_m Bernstein-polynomial functions,
 $b_{3i+1, 3j+m}$ Bezier-coefficients,
 n_1, n_2 number of patches in ξ_1 - and ξ_2 -direction.

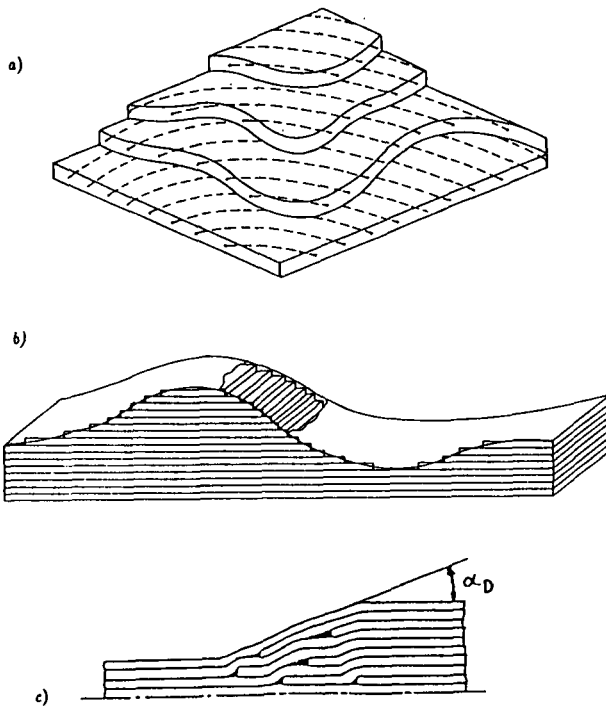

Fig. 10: a) "Mountain" of plies with the same fiber orientation
 b) Enveloping surface of the "ply group mountain"
 c) Real built-up to prevent delamination

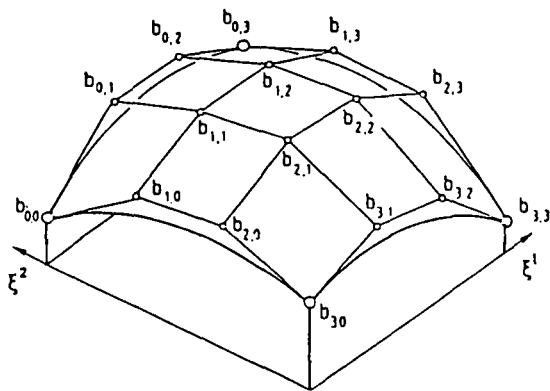

Fig. 11: Bicubic Bezier-patch

The $(3n_1+1)(3n_2+1)$ Bezier-coefficients can be expressed by $(n_1+1)(n_2+1)$ independent control points d_{ij} . In the optimization process, design variables x_k are assigned to these control points d_{ij} so that the optimal layer distribution is determined by the optimal control points:

$$d_{i,j} = d_{i,j}^1 x_k + d_{i,j}^0 \quad (3)$$

Equation (2) only describes a thickness distribution t depending on the parameters ξ_1 and ξ_2 . Additionally a relation between this thickness distribution and the structural surface $r_s(u,v)$ is required. It is advisable to parametrize the independent variables of the structural surface depending on ξ_1 and

ξ_2 . Therefore, the variables of the structural surface and are described analogous to the thickness distribution:

$$u(\xi_1, \xi_2) = \sum_{l=0}^3 \sum_{m=0}^3 f_l(\xi_1) f_m(\xi_2) c_{3i+1, 3j+m} \left. \begin{array}{l} i-1 \leq \xi_1 \leq i \\ j-1 \leq \xi_2 \leq j \end{array} \right\} \quad (4)$$

$$i = 1, \dots, n_1 \quad ; \quad j = 1, \dots, n_2$$

The surface parameter v is parametrized in the same way as u . A functional value $t(\xi_1, \xi_2)$ of the thickness distribution is assigned to each point $r_s(u(\xi_1, \xi_2), v(\xi_1, \xi_2))$ of the structural surface. The number and the dimensions of the patches for the thickness distribution can thus be defined completely independent of the parametrization of the structural surface.

4.2 Constructive design model of prepreg-courses

The following assumptions are made for the calculation of the tape-courses:

- the boundary curve of the starting course is given by discrete curve points (Fig. 12),
- the adjacent tape joins without gaps or overlaps,
- the tape steering by fiber shifting only causes shear-deformations of the prepreg-matrix but no fiber strains,
- all fiber run on "parallel" curves.
- the change of the tape width due to the shear deformation is negligible.

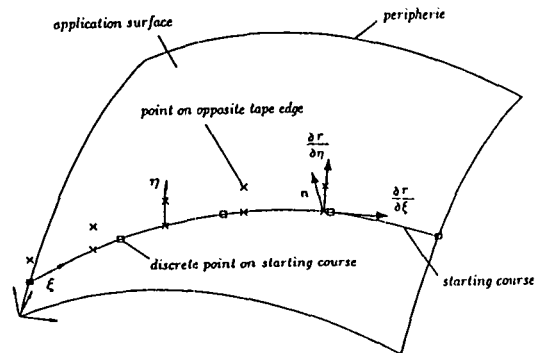

Fig. 12: Simulation of the tape courses

In a first step, a continuous starting-course is determined by connecting the discrete curve points by the means of spline-interpolation. This curve describes the tape edge of the first application tape.

With the application process the fibers in the tapes are only shifted against each other in course direction, i.e. all fibers of the viewed ply run on curves on the application surface, which are "parallel" to the starting course.

So-called "geodesic curves" (geodesics) can be calculated between both tape edges perpendicular to the courses of the fibers. These curves connect the two boundary curves of the tape at the shortest possible distance which is always perpendicular to the fiber direction and which is as long as the tape is wide.

The boundary curve of the tape considered first, simultaneously

represents a boundary curve of the gap-free and non-overlapping adjacent tape. By repeating the described process for calculating the opposite boundary curve, a sequence of adjacent tape courses can be calculated iteratively. This process is repeated until the tape courses within the periphery of the application surface are calculated completely (Fig. 13).

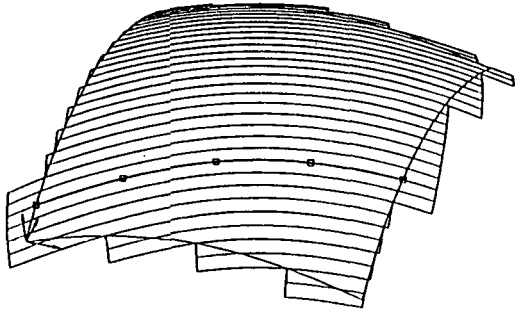

Fig. 13: Tape courses on a completely covered surface

The fiber course at a corresponding point in the tape can be determined by:

$$\mathbf{r}_T(\xi, \eta) = \sum_i f_i(\eta) \mathbf{r}_i(\xi) \quad (5)$$

where

- \mathbf{r}_T position vector of the tape surface,
- ξ independent parameter in course direction,
- η independent parameter perpendicular to the tape,
- f_i polynomial blending functions,
- \mathbf{r}_i partial curves of the tape course.

As described above, the starting course (boundary curve of the first tape) is defined by discrete points connected by a spline-interpolation. In addition to the discrete points, tangent vectors can also be used for defining the starting course. The discrete points and the tangent vectors of the starting course implicitly determine the course of all following tapes. Therefore, these points and the tangent vectors are the constructive parameters, the optimal values of which have to be calculated by the optimization process. The design variables are assigned to these parameters of the starting course for the optimization of the tape courses:

$$u_j = a_{ji} x_i + u_j^0, \quad v_j = b_{jk} x_k + v_j^0 \quad (6)$$

$$\alpha_j = c_{ji} x_i + \alpha_j^0, \quad t_j = \frac{\partial \mathbf{r}}{\partial u} \cos \alpha_j + \frac{\partial \mathbf{r}}{\partial v} \sin \alpha_j$$

where

- u_j, v_j surface variables of a point on the surface,
- α_j orientation angle of a tangent vector,
- t_j tangent vector on the starting course,
- x_i design variable ($x_i \in \mathbb{R}$).

The constants a_{ji} , b_{jk} , c_{ji} , u_j^0 , v_j^0 and α_j^0 serve for the normalization and transformation of the design variables to numerically suitable values.

5. Examples

To validate the functionality of the new constructive design model implemented in the Lagrange Program [9] two examples are shown in the following. As manufacturing constraints are included the drop-off angles, the curvature and the shear strains of the prepreg tapes. [10].

5.1 Cantilever plate

In Figs. 14a, b the results of a flat cantilever plate with a shear load on the right end are shown. A Tsai-Wu failure criteria for the composite structure and a displacement constraint at the lower right corner of the plate were applied beside the above mentioned manufacturing constraints. The problem was solved with 66 design variables (control points for ply distribution and tape courses).

Fig. 14a shows the thickness distribution for optimized straight tape courses in the two ply directions which results in an optimal weight of 2,8548 kg. Allowing tape steering with the restriction of the steering radii the optimal weight reduces about 6,6% to 2,667kg (Fig. 14b). (The quadratic markings show the starting-course of the two ply groups).

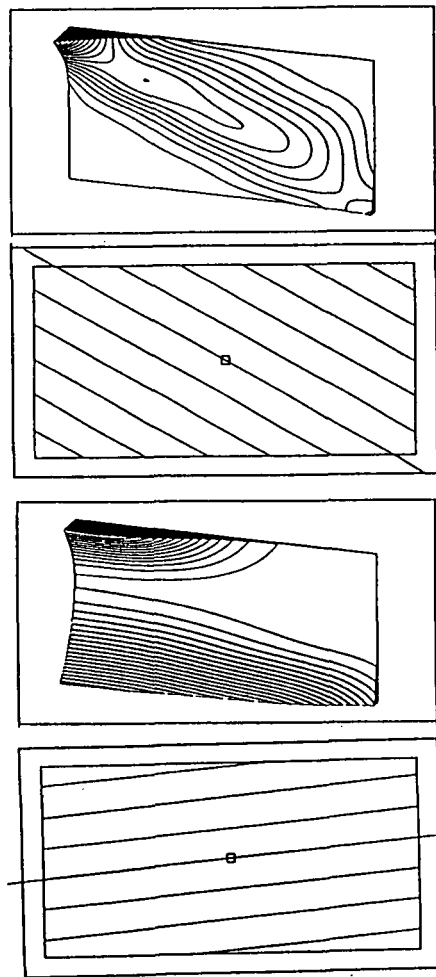

Fig. 14a: Thickness distribution for straight tape courses

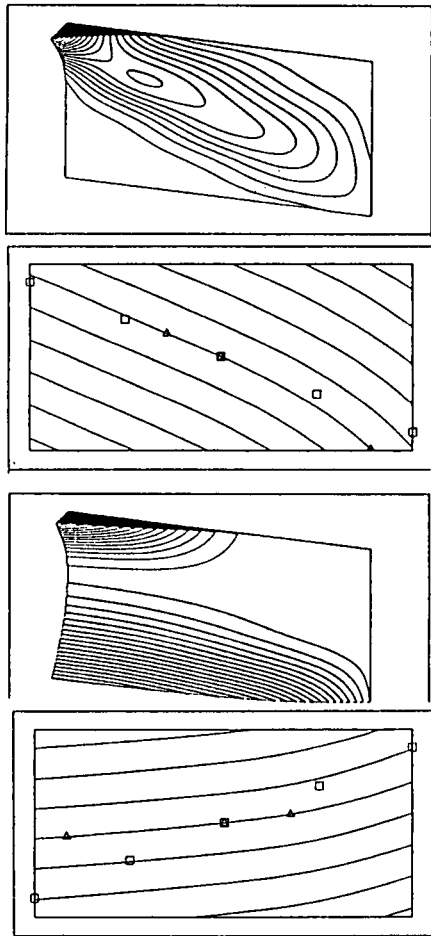

Fig. 14b: Thickness distribution for curved tape courses

5.2 Composite Fin

In Fig. 15 first results with the constructive design models for the well known MBB-Fin are shown. Beside 306 manufacturing constraints there are stress limitations for the isotropic structure, maximum strain failure criteria of the composite structure, arising from five static load cases. Two additional static aeroelastic efficiencys constraints for the fin and the rudder and a flutter speed constraint are also considered which results in a total number of 2168 constraints.

Using only the 243 control points for the ply distribution model the optimal for the ply distribution model the optimal weight is 154kg with the following ply angles:

Plynumber	Fin	Rudder
1	110°	115°
2	65°	70°
3	20°	25°
4	155°	

Allowing a rotation of the fiber orientation but without tape steering the optimal weight reduces to 140 kg (= 9% reduction) with the following angles.

Plynumber	Fin	Rudder
1	3,76°	108°
2	85,05°	100,32°
3	38,42°	174,84°
4	24,28°	

(Results with tape steering are not yet available). The optimal weight results are higher than the published results [9] with the conventional design model formulation because of the consideration to the maximum drop-off angles which does not allow unrealistic discontinuous thickness an finite element boundaries.

6. Conclusions

The traditional process of product design and manufacturing is characterized by a number of sequential subprocesses, which require a lot of iteration loops in the design phase itself as well as between design and manufacturing. The usage of CAx tools has not much improved the productivity of engineering because the managing of the tools and the produced data has become extremely complex. In order to come to a better exploitation of information technology the processes has to be investigated and if necessary redesigned.

As an example for a redesign, a highly integrated process for composite structures including design optimization is shown which returns engineering tasks from special departments back to designer. The necessity of taking care of the manufacturability in the design phase will reduce the number of iterations and interfaces.

The success of such process integrations and parallelizations could only be achieved by a strong teamwork between the different disciplines, which must lead to organisational and cultural changes in the companies.

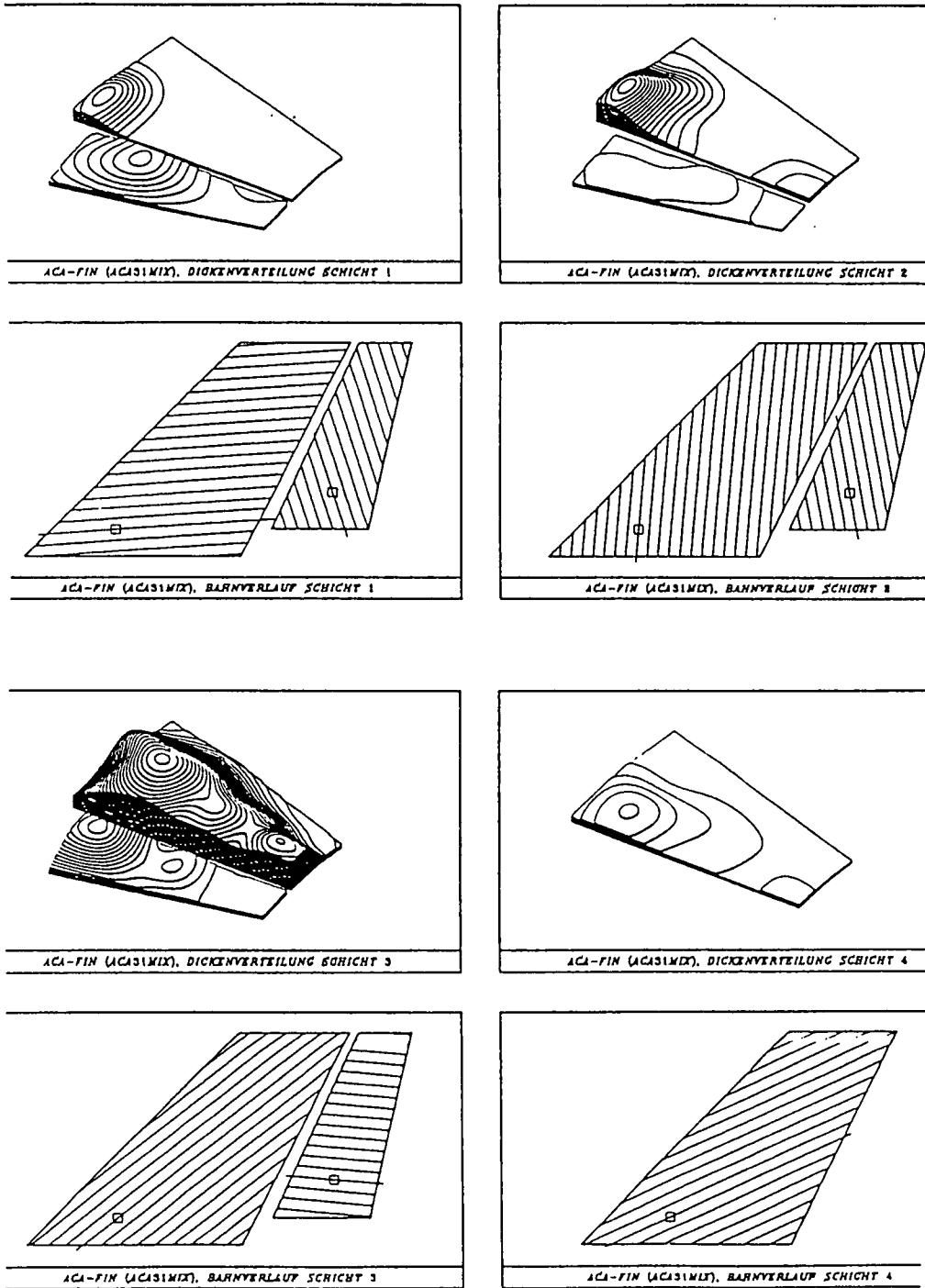

Fig. 15: Thickness distribution for straight tape courses (fin structure)

References

- [1] Berchtold, G.; Klenner, J.: The integrated design and manufacturing of composite structures for aircraft using an advanced tape laying technology. DASA/MBB Military Aircraft Division, Germany. DGLR-Jahrestagung, Bremen, Sept. 1992.
- [2] Eschenauer, H.; Schumacher, G.; Krammer, J.: Constructive design models for multidisciplinary optimization of fiber composite structures. 4th AIAA/USAF/NASA/OAI Symposium on Multidisciplinary Analysis and Optimization, Cleveland/Ohio, September 21-23, 1992
- [3] Dollyhigh, S.M.; Sobieszcanski-Sobieski: Recent Experience with Multidisciplinary Analysis and Optimization in Advanced Aircraft Design. NASA Symposium 1990.
- [4] H. Eschenauer, G. Schuhmacher, W. Hartzheim: Multidisciplinary Design of fiber composite aircraft structures by LAGRANGE. In J. of Computers & Structures (to appear in 1992).
- [5] Eschenauer, H.: Multidisciplinary modeling and optimization in design processes. Zeitschrift für angewandte Mathematik 72 (1992) 6, T 438 - T 466.
- [6] Brandis, H.: Konzeption eines integrierten Tape-Legesystems für die Application nichtabwickelbarer Luftfahrzeugstrukturen aus faserverstärktem Kunststoff. Dissertation, TU München, 1991.
- [7] Geißendörfer, K.: CATIA-GII development for an integrated design and manufacturing system in aircraft industry. ECU European CATIA Users Association, Annual Conference 1992, Mont Pellier, Oct. 12th - 14th, 1992.
- [8] Böhm, W.; Farin, G.; Kahmann, J.: A survey of curve and surface methods in CAGD. Journal of Computer Aided Geometric Design 1 (1984) 1-60, Elsevier Science Publishers B.V. (North-Holland).
- [9] Krammer, J.: Practical architecture of design optimisation software for aircraft structures taking the MBB-LAGRANGE code as an example. AGARD Lecture Series 186 "Integrated Design Analysis and Optimisation of Aircraft Structures", May 1992.
- [10] Munker, B.: Multidisziplinäre Sensitivitätsanalyse und Optimierung von Faserverbund-Flugzeugstrukturen mittels konstruktiver Entwurfsmodelle. Diplomarbeit D02/93 Institut für Mechanik u. Regelungstechnik, Univ. Siegen (1993)

Integrated Stress and Strength Analysis of Airplane Structures using the Data Processing Tool ISSY

R. Werner/Dr. M. Wiedemann/B. Evers

Scientific Publications Executive
Deutsche Aerospace Airbus GmbH
P.O.Box 95 01 09
D-2103 Hamburg 95
Germany

Summary

The Integrated Structural Mechanics System (ISSY) is a modular structured tool used to perform a variety of different structural calculations on aircraft structures. ISSY integrates all model generation, analysis and evaluation programs used in structural mechanics under one user interface, and operates a common data base for all these programs.

ISSY can be used to generate and analyze calculation models of structural assemblies (fuselage, wings, stabilizers, etc). This is performed by an interactive preprocessor implemented in ISSY. These calculations provide data for both the finite element analysis and for strength analysis^{*}), thereby avoiding redundancy of data.

Model generation is supported by the use of parameterized standard models (and/or standard sub-models). In addition, model generation is made easier by comprehensive ISSY libraries which provide material data on aluminum, composites, in addition to geometric data on profile sections and rivet allowables. The geometry input data can be directly copied from the component loft data files.

The model input data and calculation results are stored in relational data tables which can be analyzed by the post-processor implemented in ISSY.

In addition other modules convert conventionally generated calculation models into ISSY format and generate load case data. To aid partners work on international joint projects, ISSY is compatible with both standard NASTRAN and ISSY processed input and output data.

A documentation of model and result data can be obtained in every phase up the justification report.

^{*})The strength analysis system ASSACOS (Automatic System of Strength Analysis of Complex Structures) is operated in ISSY.

1. Introduction

The Structural Mechanics department of Deutsche Aerospace Airbus (DA) has responsibility for a wide range of tasks.

One major task is the determination of force distribution in global structures. In most cases this is done by means of finite element models (FE models). With these models being in the scale of 1:1, i.e. with each individual skin panel being idealised with its surrounding stringers a frames, often more than 100 000 degrees of freedom are involved. When, due to insufficient CPU capacity, rougher idealisations were performed, subsequent allocation of FE results to real components used to be rather difficult.

Another major task of the Structural Mechanics department is the strength analysis of individual structural components. In the last twenty-five to thirty years, a variety of more or less differing strength analysis (SA) programs have been developed. Some fifteen years ago, we started to order, categorize and summarize these programs. At the same time, the number of input data required for analyses increased considerably. This led to specific data models for each individual SA program. Besides, the uncoordinated development of SA programs led to a variety of interface programs for FE results application.

Interface programs have been developed for the transfer of FE results by means of an allocation table for components and finite element numbers into SA programs for the determination of reserve factors.

These SA and interface programs – known under the name "ASSACOS" [1] – have been documented in theoretical and user manuals, and ASSACOS is operated and well known far beyond Deutsche Aerospace Airbus.

As the number of complex analyses and data required increased steadily and led to inconsistencies and to time problems, it was decided to start the development of the integration concept ISSY some eight years ago.

The comparison of the above mentioned tasks and tools showed that – in spite of differing calculation methods – the data required for FE and SA models were overlapping to a high degree. If a component (e.g. skin thickness) had to be modified, this modification had to be incorporated into several models. However, for SA models it is recommended to use design designations such as stringer, frame, skin panel, seat rail, whereas FE models are determined by means of node geometry and element allocation.

In addition, numerous data are determined by characteristic values (such as standard profiles, rivet data, material characteristics); they are required for all programs and should therefore listed in catalogues.

2. Structures and Functions of ISSY

Based on this situation, the ISSY concept has been developed with the following principal targets:

One major ISSY target is the integration of all essential data and programs required for the calculation of aircraft structures. This integration is achieved by a corresponding structuring of all data provided by the Structure Data Base (SDB). All SA programs have access to this SDB, or are linked to it by interfaces, ref. figure 1.

At the same, a common surface is provided for all programs required to ensure an integrated application.

Modern procedures of generation, maintenance and evaluation of data have been integrated in the ISSY concept. Program operation represents state-of-the-art developments involving graphic and interactive functions as well as panels and windows for the user.

For ISSY operation the concept has been extended by a number of features, such as integration of external models of Airbus Industrie partners, processing of complex load distributions in FE structures (compressive loads), and processing of real load cases.

The following data have been taken into account for designing the SDB:

FE data selection for ISSY has been done in compliance with the system of elements that is generally used in aeronautics, i.e. not all features of FE programs like NASTRAN [2] have been incorporated. Thus, volume elements have not yet been included in preprocessing.

At Deutsche Aerospace Airbus, loading data for the comprehensive FE model are in general entered by means of unit load data. These data are adapted by factorisation (principle of superposition) to ensure evaluation of FE results and analysis by SA programs. There is also the possibility to process real load cases by ISSY.

Design and demonstration data represent input and output for SA programs. The output is in general effected by means of report lists. Although this output format is well suited for documentation, it is less suited for the actual analyses. Therefore, for ISSY purposes, a uniform and flexible data structure has been selected which is accessible by all SA programs. ISSY uses component designations to locate model and result data. They are of essential significance for pre- and postprocessing.

Graphic and interactive systems offer a large variety of possibilities to display and document models and results by allocation of colors and groups. This information can also be stored in the SDB, processed by other program modules, or called in subsequent sessions.

After having evaluated the advantages and disadvantages offered by commercially available FE preprocessors, it was decided to develop a separate ISSY preprocessor (PMOD) for generating an ISSY model that fulfills all requirements of FE methods (e.g. NASTRAN) as well as for strength analysis programs. PROPER, an in-house developed program for profile geometry generation and laminate description, has been integrated into PMOD.

For postprocessing purposes, which comprises the evaluation of FE analyses as well as the display of SA results, it was equally decided to develop a separate ISSY postprocessor module (GMOD). The decision was based on the fact that commercially available postprocessors (I-DEAS) do not allow processing of model data on the basis of design designations.

To combine unit load cases to real load cases, programs were developed for the determination of unit load cases for cabin pressures, air loads and inertia loads, as well as for the determination of factors for real load cases. These functions are summarized in the program module LMOD. LMOD is used also for processing aerodynamic and load distribution data which have been determined beforehand by the flight mechanics department. The results of the load

factor determination are stored in the SDB to which all modules have access.

The correlation module KMOD is primarily used to change FE and SA model data into ISSY model data. In addition, this module can be used for a comparison of models and properties and for their graphic display. KMOD is also designed for processing last data for ISSY models.

As already stated at the beginning, the finite elements method is of essential importance for the determination of stress distribution. In addition to NASTRAN integration, data interfaces have been developed for programs such as SAFE, the (FEMERG) data of which have been used for decades for data maintenance, and COSA, the program operated by Dornier.

Deutsche Aerospace Airbus uses primarily INTERLEAF for publishing documents. ISSY offers the possibility of generating graphic data in INTERLEAF formats.

In addition, various ISSY modules can be used for direct output of reports and graphics on list printers, POSTSCRIPT printers, or various types of CALCOMP plotters.

ISSY has been developed for both IBM and VAX computers. A distinction is made between computer-specific functions and actual program functions [3]. This allows an easy program transfer to other systems. Currently, we are working on a UNIX implementation on HP-systems.

ISSY has a modular system structure. The user selects the module he wants to work with and enters the required data sources into the ISSY panel or window, ref. figure 2. Each ISSY module offers default data sets. This ensures that specific data are automatically adopted with a module change.

System operation can be done in the interactive or batch mode. Specific computer knowledge is not required. After each session a log output is issued either on the screen, in a file, or on a printer.

In interactive modules (like PMOD) the user operates with menus, windows or panels. Graphics can be displayed and processed in several independent windows. Graphics for documentation purposes can be stored in a metafile, or, at user's option, edited and put out in various formats after module operation.

For data maintenance various options have been investigated and tested:

IMS, FOCUS, ORACLE. We finally decided in favor of our in-house development, a purely relational data maintenance system. FOCUS query functions [4] can also be used, just like the ISSY-SDB can be adopted into relational DB systems like ORACLE.

3. Future Development of ISSY

Currently, the ASSACOS program modules SCHADI – Strength Analysis of Stiffened Shells – and SPADI – Strength Analysis of Frames – can be used by ISSY.

For the purpose of analyzing composites, the module COMFEST is linked to ISSY. However, the functions of this program are currently being extended to integrate the analysis of stiffened shells.

The documentation modules SCHADOUT and DIAGRA used for preparing strength analysis reports and diagrams have been integrated and are operated in the interactive

mode. Links for another five ASSACOS programs are currently being prepared:

- STRIKU – Strength Analysis of Stringer Couplings
- SPANKU – Strength Analysis of Frame Couplings
- LAQUENA – Strength Analysis of Riveted Longitudinal and Circumferential Joints
- SPADI2 – Extended Strength Analysis of Frames in Complex Structures and Major Assemblies (Load Introduction Frames)
- TRAE – Strength Analysis of Circumferential and Longitudinal Beams in Passenger Cabin and Cargo Compartment Floors

Further ISSY development shall include additional links for other ASSACOS modules as well as for fatigue strength programs (crack propagation, damage tolerance) and SA programs from our partner companies.

Data exchanges with other systems like 3D-CAD or DEC-decision are also envisaged.

ISSY can also be used for preliminary design and optimization tasks, such as PMOD, which offers parameterized models and easy access to all dimensioning data in the ISSY-SDB.

References

- [1] ASSACOS – Automatic System for Strength Analysis of Complex Structures: Deutsche Aerospace Airbus GmbH; Kreetslag 10, 2103 Hamburg 95; Germany; 1990
- [2] MSC NASTRAN; The MacNeal Schwendler Corporation; 815 Colorado Boulevard, Los Angeles, California 90014; U.S.A.; 1990
- [3] VMS DECwindows – XLib Routines Reference Manual; Digital Equipment Corporation; Maynard, Massachusetts; U.S.A., 1988
- [4] FOCUS – Users Manual Release 5.0; Information Builders, Inc.; 1250 Broadway, New York, NY 1001; U.S.A., 1986

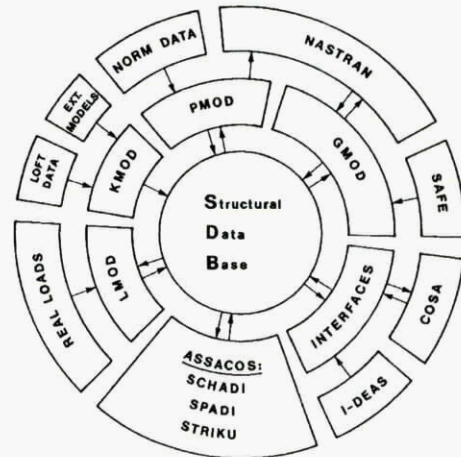

Fig. 1: Scheme of ISSY architecture

```

GMOD Graphic modul Vers:G-11.92 El: 12000 Gr: 6000 Time: 13:18
Command => A Loadcase => 503 Output(0-3)/Window => 12

Selection => QTV Attributes => DV Sequence of results => 123

Coordinate area X Y Z
from :
to :

-----
Angles to X-Axis :
Y-Axis :
Z-Axis :
Projektion plane :

-----
Plot size (cm)
Percent of shrink

GMOD title: A300-60
Load title: Lateral
Dataset : Simulta
    
```

A300-600 ST
Deformation Lateral Gust (neg.)

The image shows a 3D wireframe mesh of an aircraft fuselage, likely an A300, viewed from a perspective. The mesh is dark and shows significant lateral deformation (buckling) of the fuselage structure under a negative lateral gust. The tail section is visible on the left, and the nose is on the right.

Fig. 2: Example of working windows in ISSY

APPLICATION OF CONCURRENT ENGINEERING PRINCIPLES TO AIRCRAFT STRUCTURAL DESIGN

by

John M. Coyle
and

M. Droegkamp, T.W. Hesterman, B.L. Matthews and T.M. Wilson
McDonnell Douglas Corporation
P.O. Box 516
St. Louis, MO 63166
United States

1.0 ABSTRACT

The process of designing aircraft structure requires many functional disciplines and associated interdisciplinary coupling. To achieve optimal performance, the various disciplines must work closely together and effectively exchange large amounts of pertinent data. In the past, this was accomplished either with independent analysis tools that were not tightly coupled or with a single analysis tool that lacked the required fidelity to truly support the needs of more than one discipline. In addition, the analyses were performed in series rather than concurrently. A major impediment to process improvement was the lack of a common geometry database that could be utilized by all disciplines required to support structural design. The rapid growth of computational capability and the gradual acceptance by engineers and management to the use of automated processes and common databases has allowed McDonnell Douglas Aerospace (MDA) to implement a concurrent engineering approach to structural design.

Our present aircraft design process combines a common geometry approach and existing analysis tools with the power of engineering workstations to manipulate an integrated design database to arrive at an optimum design solution. Our modular approach divides the design process into smaller, more manageable tasks that can be performed concurrently. It achieves "buy-in" from each engineering and manufacturing discipline by incorporating existing specialized design tools that have been developed by those groups and introduced into the process without taking away ownership. We use common geometry principles, neutral file structures, widely accepted third party and company proprietary applications coupled with consistent naming conventions and file management to achieve our integrated design methodology solution. The present system optimizes the vehicle structure for minimum weight against a given set of design requirements. It is currently used to evaluate advanced vehicles such as NASP and is also being applied to more conventional aircraft.

In the future, capabilities will be added to this analysis system that allow it to be applied to detail design problems as well as increasing the fidelity of advanced design solutions. The major increase in capability will result from adding direct access to the computer aided design geometry and also in the incorporation of standard analysis checks into the system. We will design the architecture of the system such that new engineering and manufacturing applications can be easily added.

This paper will discuss the evolution of the MDA integrated design methodology from the 80's to the present as well as our vision of the future.

2.0 OVERVIEW

In the 70's and early 80's, advanced design activities used primarily historical data to predict weight for new configurations. This approach was adequate for aircraft evolving from designs of similar vehicle geometry and material systems. However, this approach proved to be inadequate for high technology, high speed vehicles, such as NASP, as well as more conventional vehicles using larger components of composite materials and having radically different shapes. This deficiency was most obvious for the design of hypersonic vehicles, which requires a high level of multi-discipline integration to satisfy design requirements. These vehicles must operate in extreme thermal and dynamic environments, yet have a low mass fraction to satisfy mission requirements. Because of the extreme environments and the non-traditional vehicle shapes associated with hypersonics, a new highly integrated structural design process was required. Our process was developed to rapidly analyze structural concepts for hypersonic vehicles and provide accurate weight predictions much earlier in the design cycle process.

When this effort began in 1985, rapidly decreasing computer costs, Computer Aided Design (CAD) and Finite Element Modeling (FEM) were widely identified as mechanisms which would integrate the engineering world. These claims were accurate, but a change in the way we do business was required to achieve the desired integration. In particular most processes were still conducted in series and very little concurrency existed in attacking the problem of structural integration. Most CAD tubes were nothing more than electronic drawing boards with designers producing 2-dimensional drawings. In many cases, these drawings were then entered into multiple FEM systems (often by hand) so that the strength, dynamics, and loads engineers could analyze their models. Loads were calculated using 2-dimensional aerodynamic methods which were only planform dependent. Structural sizing of the vehicle was highly dependent on hand analysis and "seat-of-the-pants" experience to determine structural and material system decisions. Dynamic analysis was typically performed after the design was complete, rather than during the design process. The thermal engineers did not use a FEM system at this time, instead using local "plug models" which were time-consuming to produce. Five to ten models might represent the thermal environment of the entire vehicle. Due to this lack of analysis depth and the time required to perform more detailed analyses, a large amount of conservatism was designed into the vehicles.

From 1985 to the present, McDonnell Douglas has been evolving an integrated structural analysis system in an effort to reduce the unnecessary conservative assumptions included in our vehicle analysis processes. The first step in this development was to make a revolutionary change in our approach to developing structural concepts. Prior to this change, analyses were typically done in series. Transferring data from one discipline to another was difficult and time-consuming because of different geometric meshes and in some cases different geometric configurations. The key feature to our approach was to use common geometry for each discipline and to develop translators to map data from one analysis tool to another. This common geometry approach was driven by the high degree of integration required to design hypersonic vehicles and thus the absolute requirement to work in parallel or concurrently. Figure 1 provides a pictorial overview of the system's features.

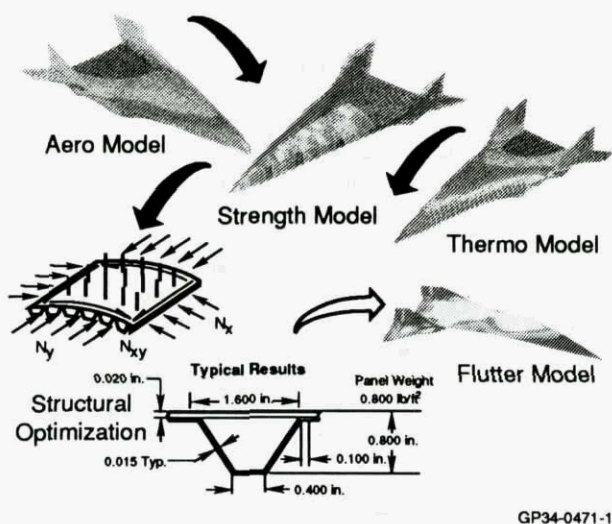

GP34-0471-1

Figure 1. Integrated Structural Analysis Increases Productivity

Since 1985, CAD engineers have been trained to use surface and solid models. Translators have been developed to interface the CAD geometry models with the FEM systems. Guidelines have been established for subdividing and analyzing entire vehicles. These rules have enabled us to develop automated data transfer and data mapping methods which integrate the disciplines. Three-dimensional aerodynamic methods and computational fluid dynamic methods have been integrated with loads using accurate data mapping techniques. Full three-dimensional transient thermal analysis is now performed to predict not only surface temperatures, but also through-the-thickness temperature gradients. These calculations are made at thousands of points on the vehicle over the entire trajectory and temperatures are mapped directly to the strength analysis model. When structural sizing is complete, the thermal models are automatically updated with the new

parameters and temperatures can be recalculated. The structural sizing codes essentially automate standard strength checks, allowing strength engineers to look at thousands of potential structural concepts and material systems to find the lightest weight design. Although not shown in Figure 1, another important feature of the system is the integration of dynamic analysis into the system. Automated methods are used to reduce the number of elements and nodes (degrees-of-freedom) in the strength FEM model, creating a new model which can be used efficiently for dynamic analysis. The properties for the dynamics model are automatically entered based on results from our structural optimization program.

3.0 COMMON GEOMETRY

The key feature of our analysis system is that it is based on a common geometry approach. The process begins with the development of a vehicle or structural configuration, as shown in Figure 2. Once the basic configuration has been defined by the designer using the Unigraphics CAD/CAM system, it is translated into PATRAN in one of three ways -- using an MDC-developed translator program, using IGES, or meshing directly using PATRAN 3.0. An individual is responsible for evaluating the surface translation and re-defining them if necessary. The breaks in the surfaces created by the designer are determined by recommendations from all the analysts who will subsequently be using them. The goal is to create one surface geometry model that will be used by all of the engineering disciplines.

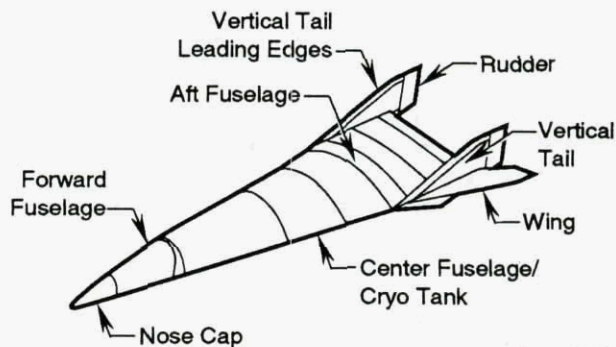

GP34-0471-2-V

Figure 2. Typical NASP Blended Wing Body Concept

When the geometry is complete, each analyst creates a mesh suitable for his discipline, working in parallel with analysts from the other disciplines. Examples of typical discipline-specific meshes are shown in Figure 3. The mesh for the aerothermal, thermal and aerodynamic loads models is created at MDA using PATRAN. The detailed inner structure of the NASTRAN model is created either with PATRAN or with CGSA, an MDA-developed code, depending on the preference of the strength engineer. Ultimately, all analysis models are returned to the PATRAN system.

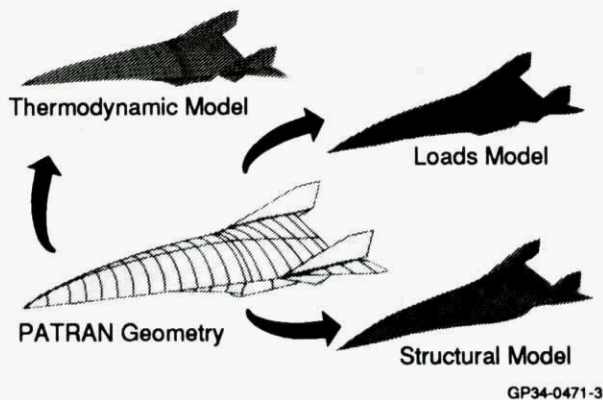

Figure 3. Different Analysis Models Generated From Same Geometry

Once the analysis models are created, each of the models is subdivided into named components, which provide a mechanism for transferring data from one engineering discipline to another using automated routines. Typical names for mapping aerodynamic pressures to the structural model are upper wing, inner tail, engine cowl, and so forth. More names are required for the thermal results mapping than the aerodynamic results, since the thermal response is impacted by the structural characteristics of each panel. Each named component in this case represents a manufacturable panel. This is discussed in more detail in the following sections.

4.0 DATA TRANSFER

The automated transfer of data between disciplines is referred to as "mapping" and is performed for each discipline's analysis model. The relaxation data mapping method uses an iterative convergence technique. Converged mapping results compare quite well (less than 2% error) with the original results, even though there may be significant differences in the meshes used by the different disciplines. The accuracy of the mapping process improves when more analysis results are available. For example, CFD results map more accurately than older 2-dimensional or panel method results.

An example of the mapping process is shown in Figure 4, where aeropressures have been mapped from an aerodynamic model to a structural model. The mapping software first determines where each aeropressure result lies on the structural model. If the result falls within a structural element, the pressure of that structural element is fixed. An iterative procedure then is used to determine the results of all remaining undefined structural elements by relaxing the results of the fixed elements and letting them drive the undefined elements to their appropriate value. Not only does this method provide accurate mapping, but it also runs quite fast.

5.0 INTEGRATED DISCIPLINES

The goals of our analysis system are increased accuracy and reduced cycle time. To achieve this, existing computer programs and engineering processes were redefined such that mission, geometry, and analysis results data were shared rather than created multiple times. Also, manual processes were automated, and higher-order methods have been added

as they become available. The result of this effort is that the disciplines are working in parallel rather than series, and that they are working at the same level of detail. An overview of this process is shown in Figure 5. The following sections discuss the methods used for thermal, aerodynamic loads, internal loads, structural sizing, and weights calculations.

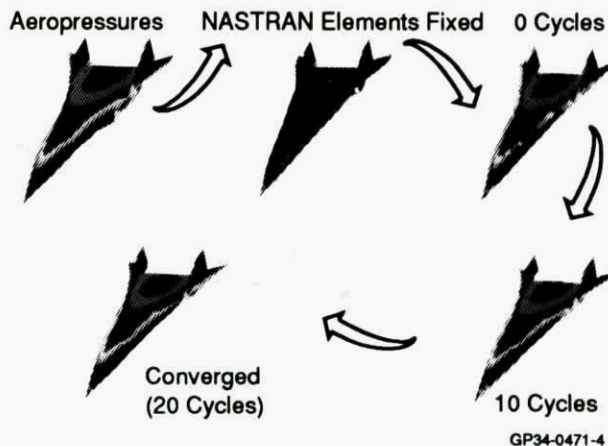

Figure 4. Data Mapping Process

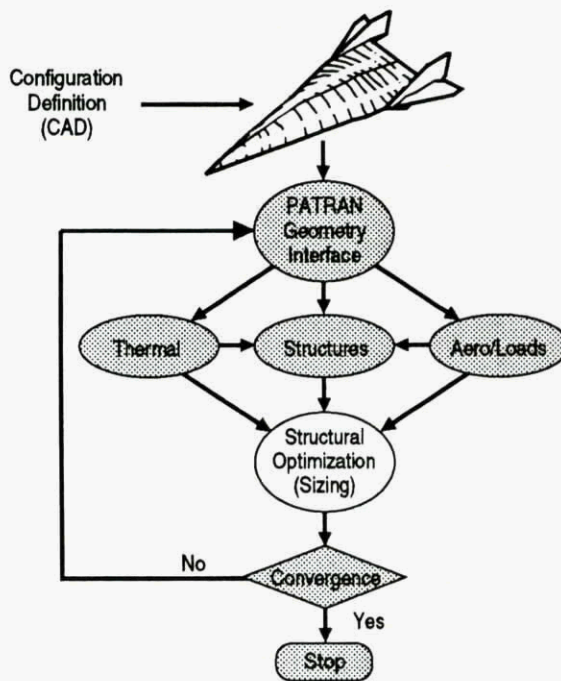

Figure 5. Integrated Analysis Approach

5.1 Thermal

One of the most critical problems facing NASP was the accurate prediction of temperatures generated by severe heating environments. This is crucial to the accuracy of structural sizing on high speed vehicles or in structural regions located within the exhaust plume of more conventional aircraft. Most structural concepts are not uniform and have concentration of masses which cause temperature differences throughout the structure. Two types of temperature gradients are important

to the structure -- changes across the surface of the moldline and changes through-the-thickness of the structural concept. These temperature gradients can generate large thermal stresses and must be addressed for the entire vehicle. The temperature gradients are calculated over the entire ascent and descent trajectory. These critical temperature conditions are then mapped to the structural model. A plot of maximum temperature gradients experienced by the vehicle over the entire trajectory is shown in Figure 6.

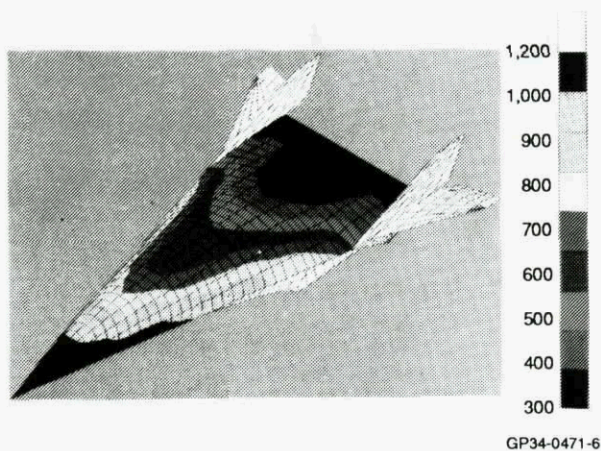

Figure 6. Maximum Temperature Gradients Ascent Trajectory

5.2 Aerodynamic Loads

External aeropressures are calculated using a variety of methods for subsonic, transonic, and hypersonic flight regimes. Surface pressures are calculated using engine and trajectory characteristics for a trimmed and balanced aircraft. Areas of the airframe with complex flow characteristics, such as the nozzle, are handled by Computational Fluid Dynamic (CFD) analysis. CFD also is used for the entire vehicle in the transonic flow regime. Calculated pressures for the design conditions are mapped onto the structural model and are used for internal load calculations using the data mapping technique described in section 5.0 and as shown in Figure 7. A key attribute of our system is that flight loads developed by a variety of analytical codes or from wind tunnel results can be applied to the structural model via the mapping process.

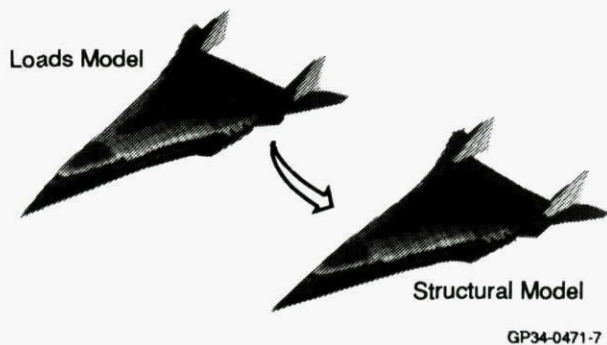

Figure 7. Airloads Mapped to NASTRAN Geometry

5.3 Internal Loads

Once the aeropressures and temperature distributions have been predicted they are mapped to the structural model in preparation for a NASTRAN run. In addition to temperatures and pressures, correct mass distributions are included in the model. NASTRAN runs are made using consistent conditions, and provide the internal load distributions for the vehicle. An example of running loads on an MD12 class vehicle is shown in Figure 8. The internal loads of the elements that define each panel (named component) are then averaged to provide the internal loads for the panel. These loads, along with the temperatures and pressures for each panel, are input to the structural optimization codes which perform detailed panel sizing.

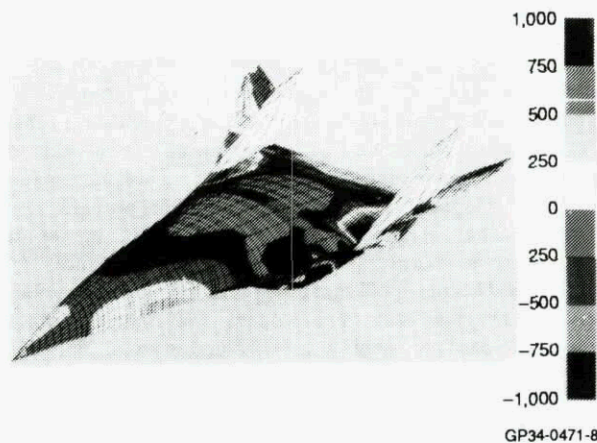
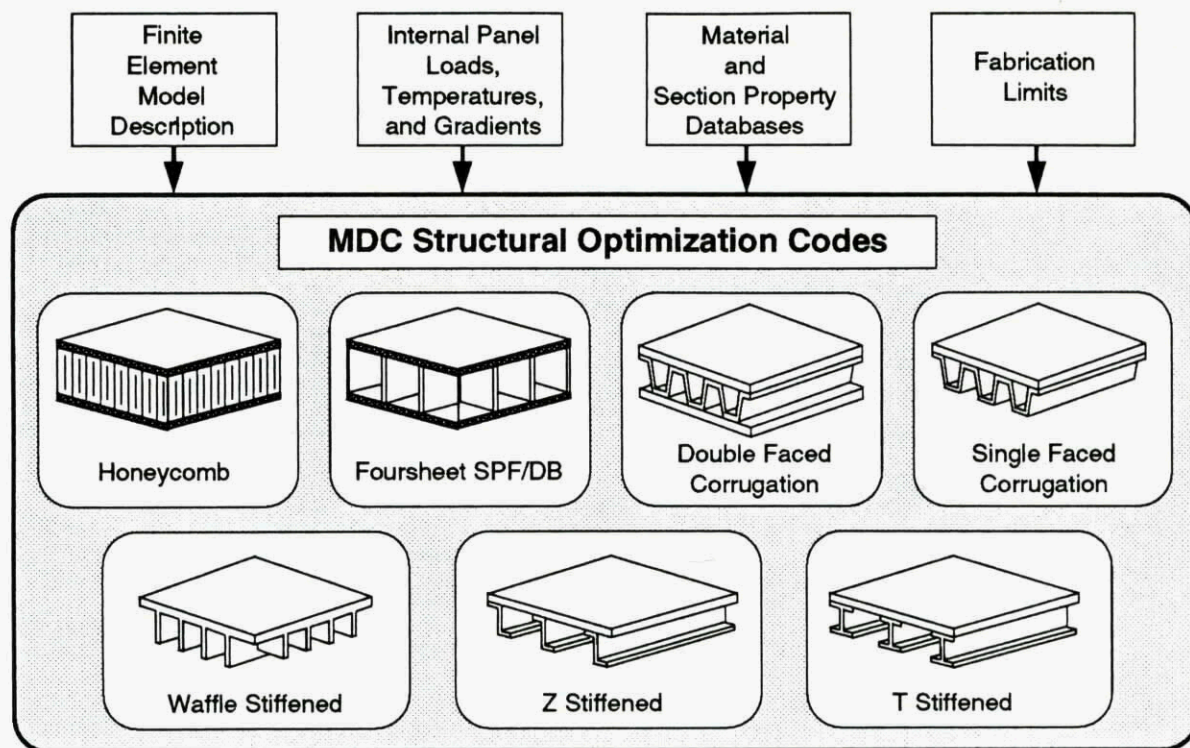

Figure 8. Maximum Temperature Gradients Ascent Trajectory

5.4 Structural Optimization

Structural sizing is accomplished with using MDA developed structural optimization programs that perform a series of strength and stability analysis checks. Several structural concepts can be selected by the user as illustrated in Figure 9. The structural concepts are: sandwich structure (honeycomb, super-plastically formed/diffusion bonded, and truss core), stiffened structure (hat or corrugations, blades), and unstiffened structure (a variation of blade stiffened). The optimization program requires that the engineer input the loading environments from the analysis database, along with the overall dimensions, the materials to be investigated, and the sizing limits.

Material properties for the analysis are obtained from an on-line material database. This database contains the information needed for engineering analysis such as mechanical and physical properties. The optimization programs access the database as needed to determine the properties of each piece of the section at specific design temperatures. A common repository for material properties provides data integrity between disciplines and for comparison with hand analysis.



GP34-0471-9-V

Figure 9. Optimization Programs Are Used to Size Acreage Panels

Sizing limits define the bounds for sizing a particular section and include limits such as section height, thicknesses, and stiffener spacing. Cross section parameters are shown in Figure 10. If a composite material is selected for sizing, the program uses composite analysis checks and correlates true laminate thicknesses to properties.

Minimum weight design is found by examining all of the sections within the limits defined by the user. Results of a typical sizing output for a hat stiffened section are shown in Figure 11. The section has actual dimensions and thicknesses identified. This type of local section geometry is necessary to accurately predict local failure modes and through-the-thickness thermal gradients. In addition to detailed section geometry, margin of safety and stress analysis summaries are available for each design condition in the trajectory.

Guidance from manufacturing, producibility, and supportability are incorporated into the sizing limits. By including these inputs early in the design phase, sized sections are less likely to change significantly as the configuration matures. Once sizing is complete, convergence for each panel is checked. If the convergence criteria is not satisfied, the sizing results are automatically input into the thermal and structural analysis models and another sizing iteration is performed. Convergence typically is reached in 3 to 4 iterations.

The optimization procedure results in a lighter weight design, since each panel is designed to its loads and temperatures, rather than all panels being designed to the highest load on the vehicle. The detailed panel weight breakdown shown in

Figure 12 is provided to the weights engineer, resulting in more accurate weights estimates for the vehicle.

5.5 Weights

Once the structure has been sized, the finite element model and the appropriate analysis results are transferred to the weights engineer and the vehicle is calculated using another MDA code, FEMWTS. Design details in the FEM such as geometry, material properties, and loading are used in conjunction with a database of structure not modeled in the FEM such as fasteners and fillets to rapidly estimate the weight of individual aircraft parts. These results are used to define target weights and can be mapped back into the structural FEM for inertial loads and dynamic analysis. The weights are also used in structural trades and cost estimating. Figure 13 provides an overview of this process.

Thousands of elements are used to model a structural assembly. They must first be grouped into detail parts before the weight analysis process can begin. Once the elements are grouped, the FEM weight analysis process can begin. Three steps are required to transform the theoretical FEM weight into a realistic weight estimate. The first step is to apply a reduction mass factor to the model to convert the strength model which represents the stiffness of the structure into a mass model. The second step adds undefined detail part weight such as lugs and fillets to the model through algorithms and part mass factors. The third step estimates the weight of structure required to attach the detail parts together into an assembly. These weights are then summed to determine the weight of the part or assembly.

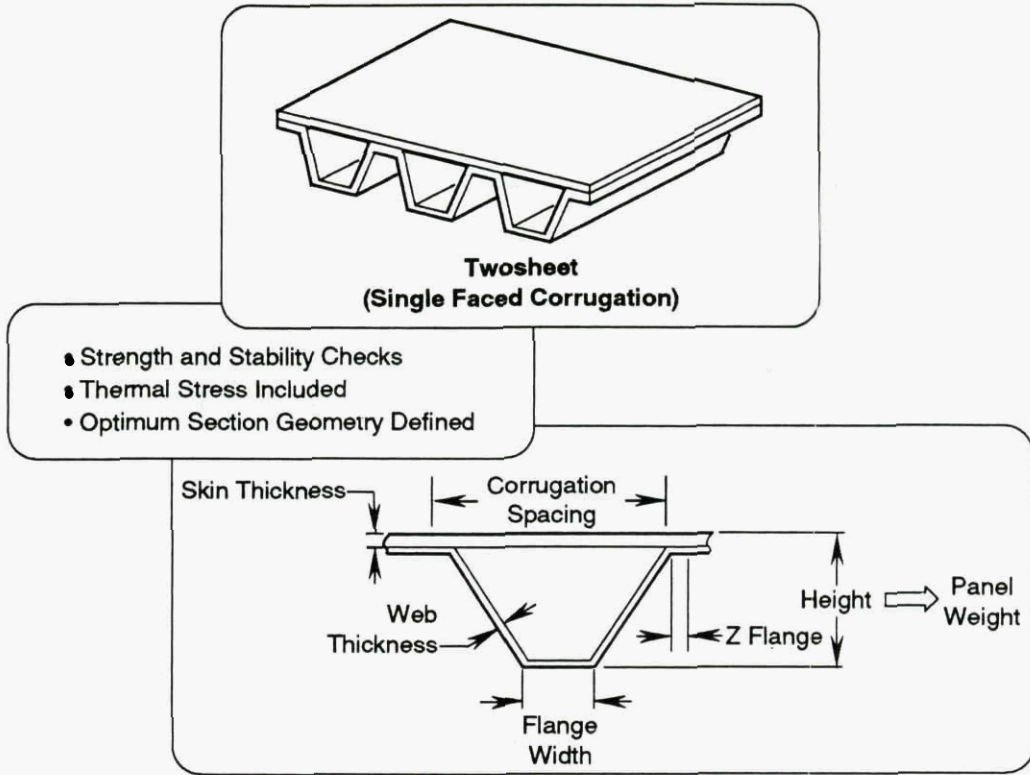

Figure 10. Detail Section Parameters of Sizing Codes

Best Geometry Based on Minimum Weight Considerations

Minimum M.S. = 0.0080

*** Panel Geometry ***

Height	=	1.50 in.	Section Weight	=	1.153 lb/ft ²
Skin Thickness	=	0.0250 in.	Web Thickness	=	0.0150 in.
Flange Width	=	0.300 in.	Flange Thickness	=	0.0150 in.
Z Flange Width	=	0.300 in.	z Flange Thickness	=	0.0150 in.

Number of Corrugations Across Width = 30 Corrugation Spacing = 1.60 in.

Margin Type = 15, Overall Panel Buckling

Load Condition 7 Is the Critical Condition

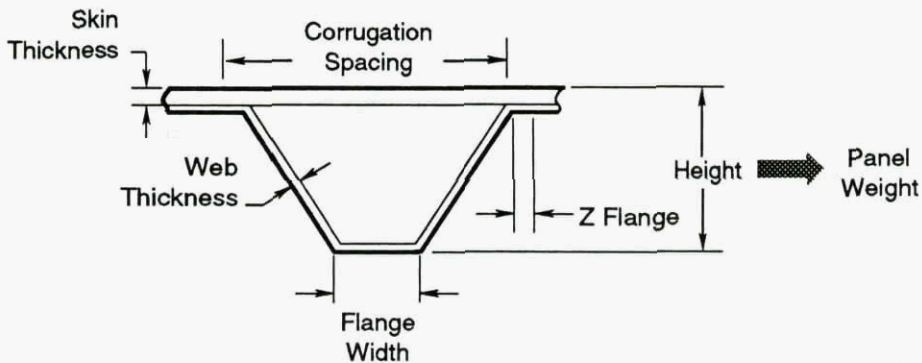

Figure 11. Sample Sizing Output

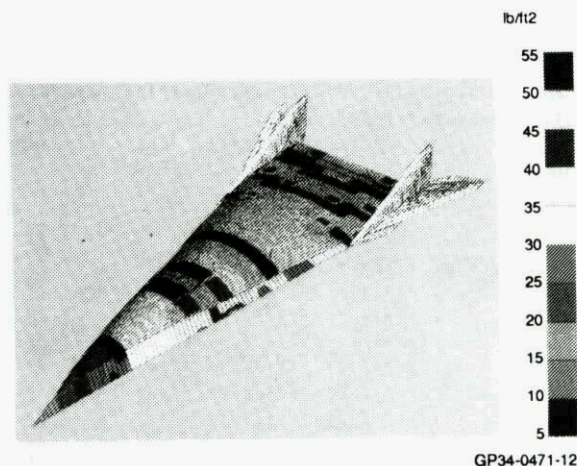

Figure 12. Panel Unit Weights

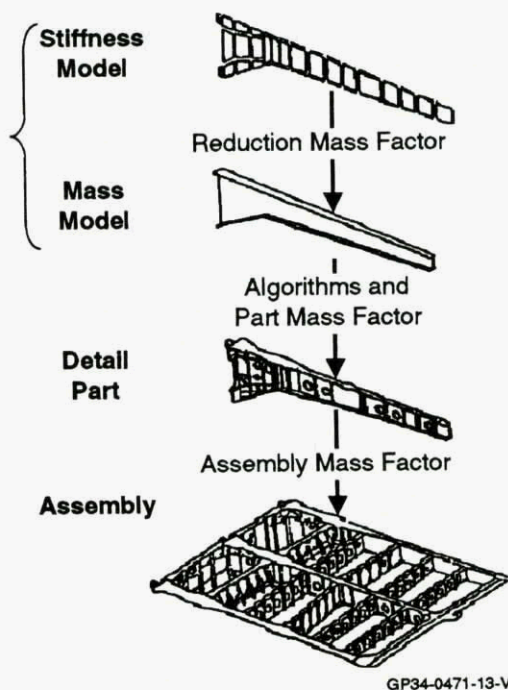

Figure 13. Advanced Materials and Structures Weight Analysis Process

6.0 APPLICATIONS

The National AeroSpace Plane uses the Integrated Structural Analysis system daily and has championed the systems use and development. The system has been used to perform most major trade studies on NASP at MDC over the last 5-7 years. In addition to its use of NASP, the analysis system described here has been used for trade studies on more conventional aircraft. The following summarizes recent applications at McDonnell Douglas of the Integrated Structural Analysis (ISA) system to support the design of advanced commercial, fighter, and space aircraft.

6.1 MD12

Wing torque box sizing was performed on the MD12 using the ISA system. Two separate trade studies were performed. The first study evaluated the weight impact of using Aluminum 7150, Titanium or Graphite/Epoxy systems. The total weight of the wing torque box for each of the materials is shown in Figure 14. We also sized the torque box using hat-stiffened, Z-stiffened, and T-stiffened structure. The total weight of the torque box using these 3 structural concepts and Aluminum 7150 is shown in Figure 15. The trade studies required 87 man-hours to complete.

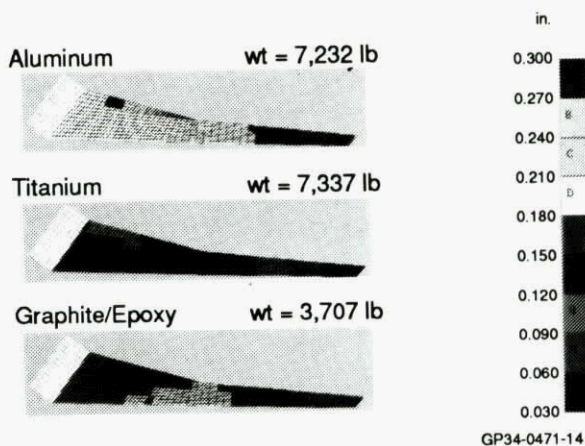

Figure 14. Composite Material Has Potential Weight Benefit

Structural Concept	Wing Skin Weight
Hat Stiffened	7,114 lb
Z Stiffened	7,232 lb
T Stiffened	7,608 lb

Figure 15. Wing Weights for Various Structural Concepts

6.2 Multi-Role Fighter

We recently evaluated three wing design concepts for the Multi-Role Fighter. The evaluation was performed using several different wing thickness/cord (t/c) designs. Static loads for +9.0 and -3.0 G and monolithic composite skins with metallic substructure were assumed for the structural sizing. The model converged in 4 iterations and FEMWTS was used to weigh each of the 3 concepts. The results showed that as the box depth was increased, although skin weights decreased, the substructure weight increased at about the same rate (thus offsetting the benefit from the decrease in skin weight).

6.3 F-18

The system was used in the early stages of the F18 E/F wing design activity to evaluate the weight impact of a 3 lug attachment versus a 4 lug attachment configuration trade study. The system was used to size the upper and lower skins and the ribs and spars for 2 loading conditions (+/- Bending). The optimized wing skin thicknesses from this study are shown in Figure 16.

6.4 Delta Clipper

The system was also used by MDC during the proposal phase of the Single Stage Rocket Technology (SSRT) program. The

system was used to evaluate 3 structural configurations. The configurations were the baseline truss cold primary structure, integral LH2 tank cold structure, and the hot structure stiffened shell configurations. An example of each of these 3 configurations is shown in Figure 17.

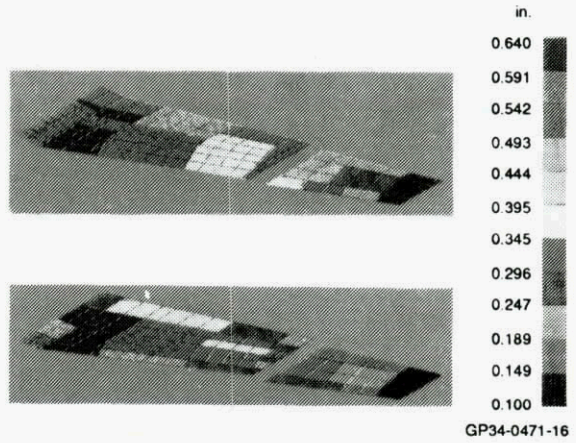

Figure 16. F/A-18E/F Optimized Wing Thickness

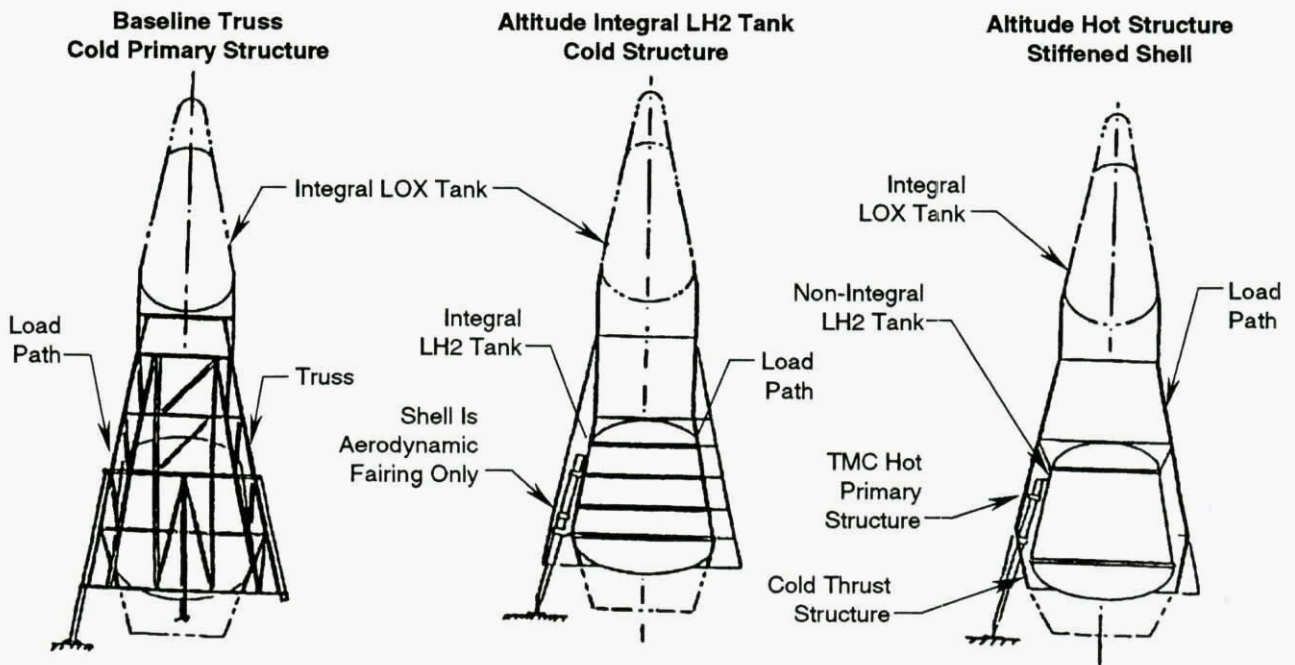

Figure 17. Alternate Load Paths and Structural Configurations Have Been Evaluated

7.0 FEATURES OF THE FUTURE SYSTEM

The integrated structural analysis system continues to evolve and be refined. We plan on adding features to the system which will allow it to be applied to detail design problems, as well as, increasing the fidelity of advanced design solutions. In the future, we will implement new capabilities in the areas of geometry manipulation, analysis methodology, and automation technology. Planned features in geometry manipulation include: direct analysis and meshing of the CAD geometry, rapid modeling capabilities for creating analysis models, and increasing the use of solid models in the design process. In the future we will be implementing advanced design optimization technologies, P-method solvers, and increase the detailed part analysis and optimization capability of the system. We will also continue to exploit automation technologies in the areas of reconfigurable process management, product data management, engineering workstation technology, and visualization technologies.

7.1 Geometry

To further reduce the cycle time in the analysis process we will implement capabilities which will provide for direct meshing and analysis of CAD geometries. This will be accomplished by implementing mesh technologies that work on all CAD surface and solid definitions. This capability will eliminate the present function of transferring the CAD geometry to our finite element meshing programs using IGES. In addition, direct meshing of solid models coupled with P or other analysis solvers will increase the speed and accuracy over present analysis methods.

We will also be implementing a rapid modeling capability for engineering analysis technologies. Presently, engineering spends much of their time developing finite element models. Computer Aided Design systems are offering new modeling techniques which engineering can exploit, such as, entity associativity and named attributes. We will utilize the entity associativity features to provide the ability for our analysis methods to automatically update the CAD geometry. We will also develop methods for passing design attributes, such as, section type, material, and manufacturing and assembly process information between analysis tools. Implementation of features such as these will reduce the amount of time it takes to analyze and update designs.

7.2 Analysis Methodologies

We will develop and implement analysis methods which will allow the system to transition from an advanced design tool to a detailed design tool. We plan to add the ability to optimize detailed parts and to implement P-method and boundary element solvers to increase the fidelity of our structural analysis tools. We also plan to implement engineering analysis methods which allows for rapid analysis and optimization of detailed surface and solid parts. Implementation and training in the use of these tools will enhance the accuracy and reduce the cycle time over the methods presently being used to analyze these parts.

7.3 Automation Technology

We plan to develop a process and data management control system. Due to the flexibility of the system, the users' of the process tend to lose sight of the best path to take when using it. We will develop a set of standard process templates which will guide the engineer through the analysis process. In addition, the flexibility to modify the process using a "motif-like" user interface will be provided. This tool will allow for the standard processes to be modified and saved. The modified process template will then control the flow of data through the system and provide project status to the appropriate management personnel. An example of how this reconfigurable process control system might look to the user is shown in Figure 20.

Computer technology continues to explode in the areas of cost performance and graphics visualization. Desktop workstations with MFLOP ratings comparable to CRAY speeds are already available. The increased availability of these CPU cycles will allow new types of solutions to be applied to old problems. In addition, new graphics technology is allowing the user to view more information in a shorter amount of time. We are planning on moving more detailed engineering analysis results visualization towards these new technologies.

8.0 CONCLUSION

At McDonnell Douglas, we have developed a flexible engineering design and optimization system which uses existing computer codes and engineering methods. Using basic system development principles such as common geometry, neutral file structures, and automated data transfer, we have developed a system which can be tailored to meet the needs of most aircraft structural design problems. With this process and with the increased efficiencies in computers we have been able to reduce our design cycle time on programs such as NASP from 6 months to 6 weeks, while increasing our confidence in the results. In addition, we will continue to enhance the system with the use of rapid modelers, new optimization methods, exploiting the latest in computer technology, and by adding process management techniques.

SOME PRACTICAL PROBLEMS IN MULTIDISCIPLINARY DESIGN AND OPTIMISATION

D.J. Laan
 H. Walgemoed
 C. Schimmel
 R. Houwink
 Fokker Aircraft B.V.
 P.O. Box 7600
 1117ZJ Schiphol-Oost
 The Netherlands

1. SUMMARY

Structural optimisation software bears a great promise in multidisciplinary design as an effective way to find an optimal balance between the requirements from different disciplines. However, successful application depends heavily on the context in which the software is used.

First of all, clearly defined design objectives are needed. The design of a modern transport aircraft is primarily determined by market driven requirements (required functionality for minimum cost) instead of technological advancement. This demands a strong emphasis on cost reduction, complicating the optimisation process.

Secondly, accurate prediction of design loads is a prerequisite for successful structural optimisation. Most aircraft structures are dictated by strength rather than stiffness requirements. So it is clear that the quality of loads predictions has a major impact on the quality of the result of the structural optimisation process. However, due to the evolution of the airworthiness requirements and the increased complexity of aircraft systems it has become increasingly more difficult in the last few decades to establish the design loads. Thus a clear need exists for quick and reliable load estimation procedures. The paper discusses some measures that can be taken to improve the load definition process.

Finally some examples of successful application of structural optimisation software at Fokker Aircraft are given. The primary advantage of structural optimisation software is that it aids a skilled designer in gaining a feel for the design space. It should thus aid the designer in his creative task instead of distracting his attention to using the software. This requires the software to be user friendly and to have built-in features for global and local sensitivity studies.

2. INTRODUCTION

Rapidly increasing computer power and improved modelling techniques have stimulated the use of computers in the design process. In structural design the Finite Element Method is a well established tool. In the last decade FEM-based structural optimisation software has gained a lot of attention. In ref. 1 a review of developments in multidisciplinary optimisation software for aircraft structures is given.

Structural optimisation software bears a great promise in multidisciplinary design: it can be an efficient way to find an optimal balance between the requirements from different disciplines. However, successful application of structural optimisation software depends heavily on the context in which the software is used. To be successful it must be embedded in the overall design process (fig. 1.):

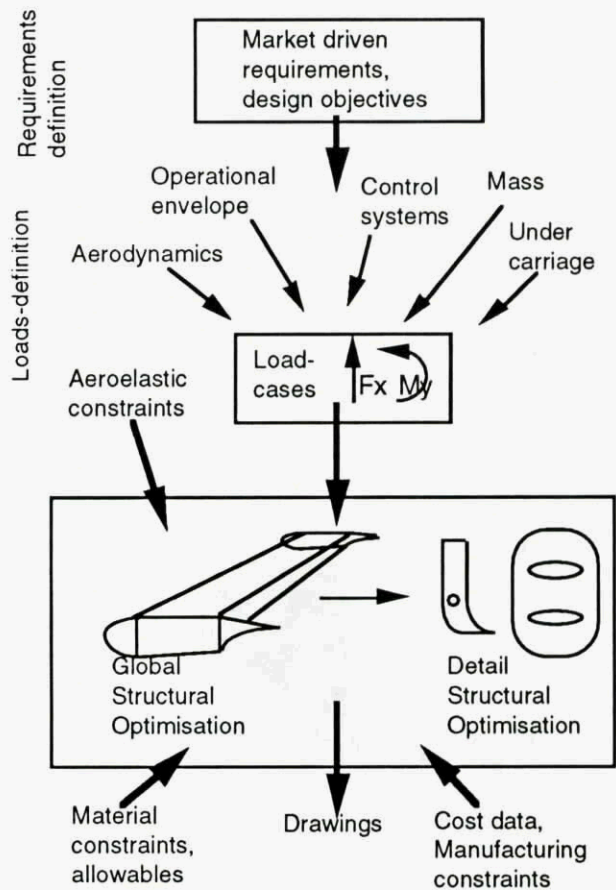

Fig.1: context for structural optimisation.

First of all, clearly defined design objectives are needed in order to get a proper optimisation criterion. In section 3 some considerations on these design objectives are presented: obviously cost data will play an increasingly important role in modern aircraft design.

Secondly, accurate prediction of design load-cases is a prerequisite for starting structural optimisation. This may sound rather trivial but in practice this requirement is rarely fulfilled. Already in 1957 Prof. van der Neut (ref. 2) concluded that the factor of safety is needed almost entirely to account for uncertainty in external loads and only a very small part of it accounts for scatter in strength of aircraft. In 1990 van Dullemen (ref. 3) stated that "the importance of structural analysis is that it has to show that in the end the structure is still strong enough for the latest set of loads. there seems to be an imbalance between the urge to sophistication in strength analysis and the level of accuracy of external loads". Although perhaps for different reasons, they came both to the conclusion that the accuracy of external loads is the most crucial factor in structural design.

Obviously in the design-phase there is still a lot of uncertainty in the dimensioning load-cases. In section 4 some difficulties in the loads definition process are described. Section 5 discusses the possibilities of improving multidisciplinary design in general with a focus on the loads definition process. Finally section 6 gives some examples of the application of optimisation software in structural design at Fokker Aircraft.

3 . DESIGN OBJECTIVES

The commercial aircraft industry has entered its maturity phase. The design of a modern transport aircraft is primarily determined by market driven requirements (required functionality for minimum cost) instead of technological advancement. Application of new technology has to be balanced against its influence on aircraft operating cost. The influence of cost considerations in aircraft design is clearly shown in ref. 4.: a comparison is made between designs for minimum life cycle cost, Direct Operational Cost (DOC), acquisition cost, minimum fuel and mass. A breakdown of the DOC of a transport aircraft (ref. 5) is shown in fig. 2.

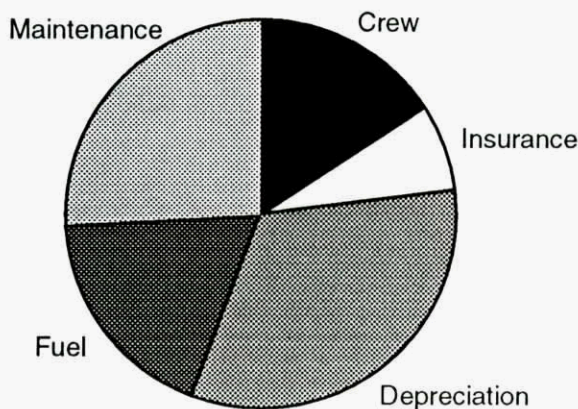

Fig. 2: breakdown of direct operational cost

The three most important components are fuel cost, maintenance and depreciation. So it is not surprising that the designer of aircraft structures is increasingly

confronted with maintenance aspects and production costs.

On the revenue side it is useful to have a look at the mass breakdown of an aircraft. In fig. 3 the breakdown of the Design Takeoff Mass (DTOM) of the Fokker 100 is shown.

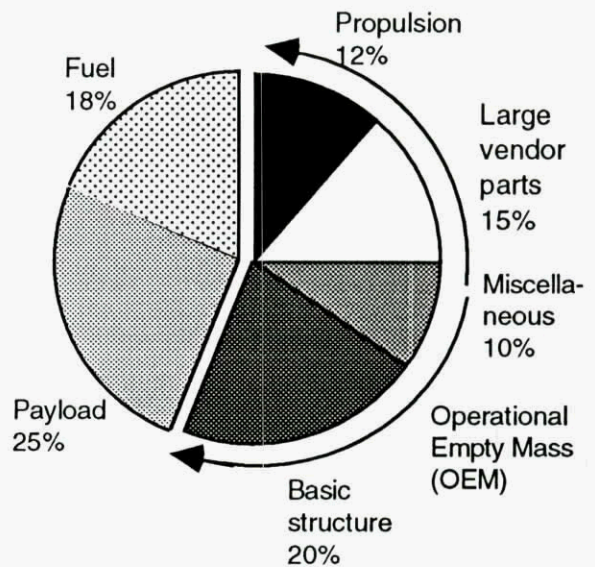

Fig. 3: breakdown of DTOM of Fokker 100

Some comments can be made with respect to this breakdown:

- Payload is the most important parameter for transport aircraft. The leverage of reduction of the Operational Empty Mass on payload increases if the payload portion is smaller. Thus the emphasis on mass reduction will vary accordingly. For instance, a rough indication of the allowed expenditure per kilogram mass reduction per aircraft:
 - a helicopter project (payload 10%): \$5.000.
 - a transport aircraft project (payload 25%): \$600.
- The basic structure is only about 20% of Design Takeoff Mass. Therefore, the influence of a change of basic structure mass on external loads is relatively small.
- Three main areas for mass reduction exist:
 - 1: Large vendor parts, like avionics units, wheels, brakes, emergency equipment etc. Mass reduction is based on the ability to get the proper contractual guarantees.
 - 2: Miscellaneous, that is cabin interior etc., generally referred to as "artists' work" by the mass engineer. Mass reduction is based on giving the artists a "conscience" by imposing strict mass control.
 - 3: The basic structure, mass reduction is primarily based on the quality of the structural design process (quality of external loads, dimensioning rules, optimisation).

Concluding it can be said that, although design to cost issues will have an increasing influence, mass reduction remains an important issue in aircraft design. Structural optimisation is aimed at reduction of about 2/5 of the Manufacturing Empty Mass of an aircraft.

4. DETERMINATION OF LOADS

The loads definition is a complex process in aircraft design. Loads are influenced by almost every aspect of the design. In order to run structural optimisation software it is necessary to know the design loads, or at least preliminary estimates of the design loads. However, the loads cannot yet be determined with high accuracy in the preliminary design stage. So the design process has to start with relatively crude assumptions concerning the design loads. As more information becomes available during the design process (e.g. aerodynamic data, mass and stiffness data, systems characteristics), loads can be established more accurately, enabling further iterations in the optimisation process.

Most aircraft structures are dictated by strength rather than stiffness requirements. So it is clear that the quality of loads predictions has a major impact on the quality of the result of the optimisation process.

Due to the evolution of the airworthiness requirements and the increased complexity of aircraft systems it has become increasingly more difficult in the last few decades to establish the design loads. Some illustrations of this trend are:

- Gust loads must be calculated according to the Tuned Discrete Gust concept, leading to a vast number of time histories to be considered for the selection of critical conditions. In addition, the Continuous Turbulence requirement has to be satisfied, which involves the calculation of many sets of correlated loads. For all of these analyses a fully flexible structural dynamic model has to be used, and an accurate method to predict the unsteady aerodynamic loading is needed. Previously, gust loads could be based on the simple so-called Pratt formula, representing a one degree of freedom (heave only) discrete gust analysis.
- Gust and manoeuvre loads are highly dependent on systems, such as the flight control system and active control systems. These systems may have complex control laws. Close co-operation between among others the systems and loads departments is required in order to obtain an optimal design of these systems, taking into account all relevant systems effects, including nonlinearities and the effects of failures and their probabilities (ref. 6,7). In the early stage of the design a Systems Safety Analysis (SSA) should be carried out. The required redundancy, loading, and damage tolerance requirements are fully dependent on the results of this analysis. The loads department should select all loads-relevant failure cases from all failures given in the SSA. In the past, these systems were relatively simple (e.g. yaw dampers) or did not exist.
- Landing loads have to be determined by dynamic analyses using flexible dynamic models of the undercarriage and the airframe. Because according to the regulations the method of analysis may be modified on the basis of flight test measurements, it is

likely that accurate landing loads will not be available until late in the development process. Formerly only some relatively simple 'book cases' were applicable, e.g. to calculate the spin-up and spring-back loads.

From the foregoing it will be clear that the final certification loads are not available until completion of flight testing. Therefore it is necessary to base the structural design of the aircraft on another set of loads. Ideally, these design loads are slightly conservative with respect to the final certification loads, but their conservatism cannot be guaranteed in advance and too much conservatism (or, more generally, too large errors in the loads predictions) may lead to a sub-optimal design or can even render the optimisation process useless. An early and accurate prediction of the loads is thus a condition for a successful structural design optimisation.

For practical purposes the structural optimisation must be based on a relatively limited set of load cases, not more than a few hundred. For design and for certification, however, many more load cases have to be investigated. Their number may be in the 10^4 to 10^6 bracket. It is thus necessary to reduce this number of load cases by means of an appropriate reduction/selection process. Good co-operation between the loads and stress departments is required to establish the selection criteria. The automated selection process may be more complicated when some of the load cases have not yet been calculated, but still have to be estimated.

It is evident that a need exists for quick and reliable load estimation procedures early in the design process. In the next section some measures will be discussed that can be taken to improve the loads definition process.

5. MULTIDISCIPLINARY DESIGN AT FOKKER

A key element in engineering design is the use of approximations to solve the design task. These approximations are clearly shown in the variety of computer models used. Fokker started to use computers for aeroelastic calculations on the F27 in 1955. Although simple computational models were used, useful data were obtained. Soon after, other disciplines followed in the use of computers. In 1976, when the first "engineer friendly" DEC10 computer arrived at Fokker, almost every discipline had automated its design methods to a considerable degree. This effort was generally uncoordinated resulting in islands of modelling and automation. This was not felt as a problem because of the clear benefit of speeding up and increasing the quality of the local processes.

However, the goal of modern aircraft design is to optimise the total aircraft rather than the individual components. Achievement of this goal requires a close co-operation between all disciplines influencing the design. A primary success factor is the capability of interdisciplinary communication. It was concluded that the islands, although efficient and comprehensible, also had their drawbacks:

- it resulted in time-consuming "translation" of data.

- models were different in many details, obscuring the necessary communication.
- consequently methods for estimating for example mass, aerodynamics and stiffness were too slow.

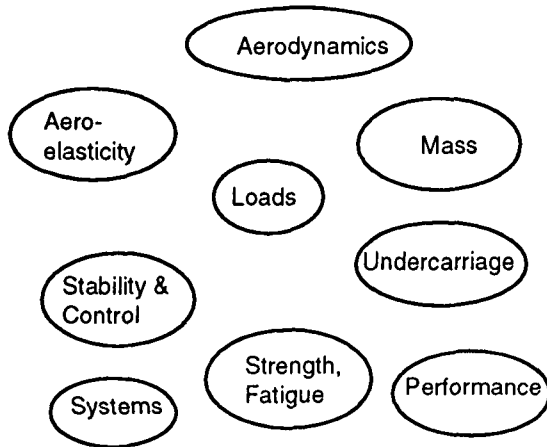
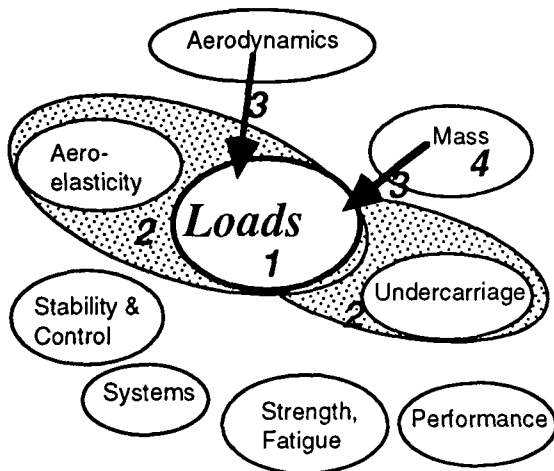

Fig. 4: islands of modelling and automation

This conclusion resulted in a more systematic effort at Fokker to improve the design process. Two Multi Disciplinary Design (MDD) groups were formed:

- project group "MDD structures", aimed at integration of the structural design process.
- project group "MDD flight dynamics", aimed at integration of different aspects of aircraft dynamics.

Clearly the two groups have a lot of interconnections. One popular result was a poster showing the basic interactions between disciplines and the different models they use. It was used as an aid during the discussions about opportunities for process improvement.



- 1: re-orientation
- 2: model integration
- 3: automated data-translation and transfer
- 4: quick and reliable estimation methods

Fig. 5: opportunities for process improvement

Current actions to improve the design process focus on the following subjects:

5.1. re-orientation

Good communication between the members of the design team is needed, because decisions which were traditionally made within one discipline may have a much bigger impact on other disciplines than before. An example is the previously mentioned interaction between systems and structures. This communication must have the attention of programme management, e.g. through the creation of interdisciplinary teams which are responsible for certain well-defined tasks. Programme management is also responsible for formulating the right design requirements on which the design must be based. These requirements must be clearly known and understood by everyone concerned. The progress of the design process must be reviewed periodically or on the basis of milestones to be achieved, e.g. by means of design reviews.

One example is the necessary re-orientation of the loads department. The newly defined design process has major implications for this department, which traditionally gathered all the necessary information and then started to calculate the resulting design loads. The challenge was to calculate the loads accurately, to include all relevant dimensioning load cases and to show compliance with the certification regulations. But in modern aircraft design the job of the loads group is even more challenging. The possibilities of influencing loads have grown due to new system concepts (load alleviation function, flight envelope protection, stability augmentation systems, autoland). This requires a change from a reactive to a proactive attitude. The loads department is moving to the centre of the design process, fully participating in the early decision making process.

5.2. model integration

As mentioned before, different disciplines use their own abstractions, model conventions and software. Often this is not a real problem but multidisciplinary optimisation can be obstructed by the time-consuming "translation" of data from one model to the other. Communication can be improved significantly if different disciplines are able to use the same model: communication can be done at the same level of abstraction without all kinds of detail modelling differences obscuring the discussion.

One might think of building a global program which will solve all of the modelling problems. But potential problems for such an MDD-system are: global programs take years of development time and an unpredictable resource consumption. Furthermore, when they are finally developed, they are incomprehensible to the ordinary aircraft designer, because he is unable to transform his experience with existing models to the new system. Rather a step by step approach is being pursued: special working groups, resorting under the MDD project groups, focus on tackling one piece of the puzzle. This approach allows for close participation and corrections during the process.

Some examples of model integration activities are:

- integration of the undercarriage model with the structural loads-model for simulation of critical landing and taxiing load cases.
- integration of the structural models for aeroelastic and loads calculations.
- integration of the GAMMA modelling system for Computational Fluid Dynamics (CFD) and the NASTRAN structural model with an advanced method for transonic aeroelastic simulations (ref. 8).
- integration of modules (aerodynamics, engine, systems, undercarriage) to build an aircraft simulation tool for studying:
 - handling qualities
 - loads due to instationary manoeuvres
 - control laws

5.3. automated data-translation and transfer

A basic problem in data-translation and transfer is non-uniformity in definition of axis-systems and units. A lot of time is wasted due to misunderstandings arising from incompatible definitions. If data-translation is to be automated, this is a first item to resolve. Furthermore, it is useful to pursue a database centred approach in order to reduce the number of interfaces required: a central file-structure supports a variety of applications, communication is accomplished via this file structure.

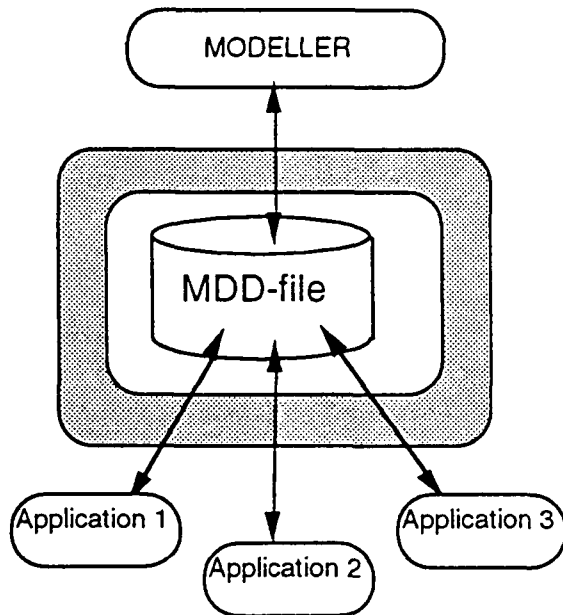

Fig.6: database centred approach in datatransfer

This approach has basically been followed during the restructuring efforts. In practice, this means that the number of file structures will be reduced, but not brought back to one!

5.4. quick and reliable estimation methods

Quick and reliable estimation methods are necessary early in the design process. In structural design, load estimation is crucial but reliable estimates can only be made if the essential input data is available. Starting point for estimation methods is a parametric preliminary design and

the external aerodynamic shape usually designed with CFD-codes.

Some examples of current activities:

- estimation of mass data (empty aircraft + all relevant payload/fuel conditions).
- estimation of stiffness: based on the external aerodynamic shape + structural concept.
- estimation of aerodynamic data using CFD-codes, empirical rules and rules for scaling aerodynamic data from previous projects.

6. OPTIMISATION EXAMPLES AT FOKKER

In this section some examples of the application of optimisation software in structural design at Fokker Aircraft are presented. The examples are concerned with the design of structural details. Although not really spectacular they do reflect the general attitude of the structural designer towards formal optimisation: many structural design problems are considered as being too complex to be supported by optimisation software, because of the many aspects to be considered simultaneously (fatigue, damage tolerance, production constraints, cost, maintainability etc.). Optimisation of structural details is considered as more comprehensible for formal optimisation procedures, the problem has a well defined scope, dimensioning loads are available and it is more obvious how cost data should be taken into account.

6.1. Fuselage cut-outs

The first example is the development of a design tool to aid in the design of fuselage cut-outs. Pre/post-processing procedures are developed using PATRAN, MSC/NASTRAN is used as solver/optimiser. Development of the design tool is a co-operative effort of Fokker Aircraft and the Delft University of Technology.

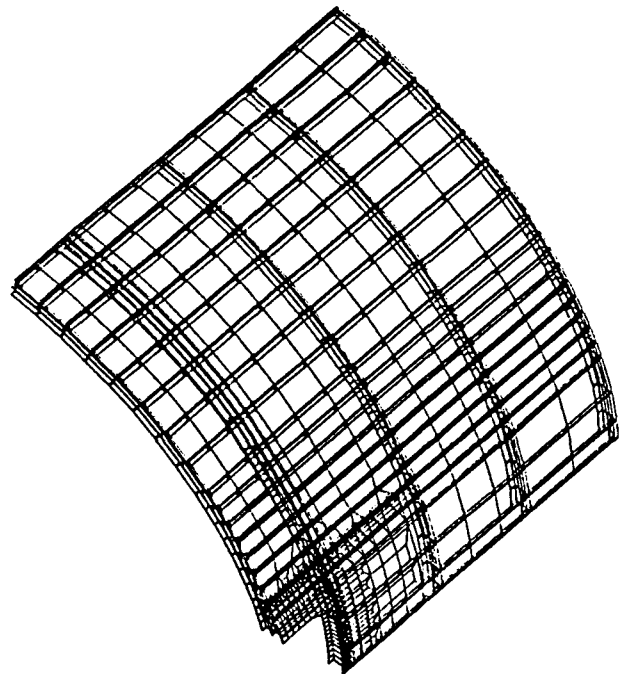

Fig. 7: structural model of fuselage cut-out

Purpose of the design tool is to determine:

- shape and thickness of skin-reinforcements (frames, doublers) around the cut-out.
- skin thickness
- shape of the edge stringers
- the corner radius of the cut-out

Objective is mass minimisation. The shape of the doublers and the corner radius can only be optimised by design variation i.e. manual sensitivity studies because shape optimisation is not yet available in MSC/NASTRAN, though it can provide local sensitivities for changes in node position.

6.2. Stiffened panels

The second example is an optimisation code for stiffened panels, PANOPT (ref. 9,10). This program is capable of analysing and optimising composite prismatic panels subject to constraints with respect to buckling, strain, stress, displacements and technological limits. The objective of the optimisation is mass reduction. The set of design variables consists of, for instance, stiffener pitch, stiffener height, skin laminate thickness and fibre orientation.

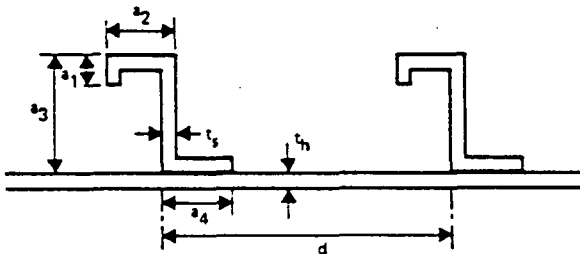
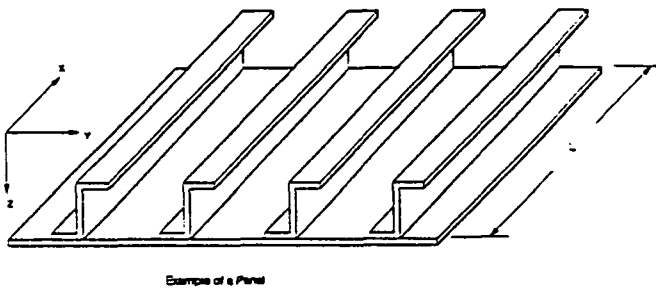

Fig. 8 example of a stiffened panel and some of its design variables

Two aspects can be recognised in optimising a panel. The first aspect is the geometry i.e. position and shape of stiffeners. The second aspect is the lay-up of the composite layers. When production constraints are taken into account, it is much easier to change the geometry without cost penalties than it is to change the lay-up. Production constraints impose for instance discrete layer thickness

and preferred size and directions of the layers. But also damage tolerance considerations impose limitations on the lay-up. The geometry is optimised using PANOPT. It allows the designer to gain insight very quickly in the influence of stringer shape and pitch. This insight is used in application of the stiffened panels in for instance wing design.

6.3. Shape optimisation of structural details

The third example is concerned with shape optimisation of structural details such as brackets, plate elements etc. The Mechanica, Applied Structures optimisation software of RASNA corp. (ref. 11) is used for this purpose. This product is a good example of how optimisation software should support structural design.

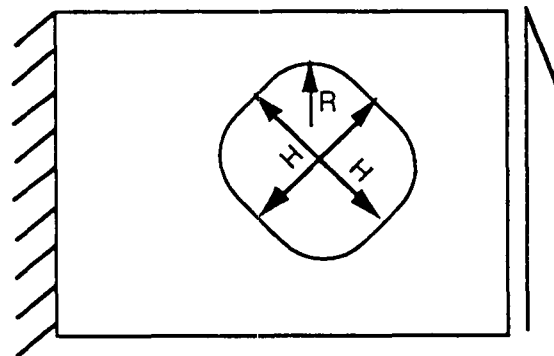

Objective: maximise size of the hole.
 Design variables: R and H
 Constraints: maximum allowed stress

Fig. 9: typical optimisation problem of a structural detail

The software is based on the Geometry Element Method, making model build time relatively short. The optimisation strategy is very well supported by the software:

1. Build the model and get a feel for the design problem. The software supports this step with comprehensive modelling capabilities, convergence control, convergence graphs and extensive post-processing.
2. Sensitivity study: this is supported by possibilities to define the design variables, shape animation to explore the design space, automatic global and local sensitivity-studies, sensitivity graphs etc.
3. Optimisation: supported by a monitoring function on the automatic optimisation process, review of optimisation history and evaluation functions on the optimum design.

Step 1 and 2 are most crucial in the optimisation process and require extensive knowledge of structural design (exclude details that are unimportant from a structural standpoint, select appropriate elements and select the important parameters for optimisation). Step 3 is fairly straightforward if the first two steps are carried out properly.

7. CONCLUDING REMARKS

Multidisciplinary design and optimisation is primarily based on the ability of groups to communicate effectively. It is believed that multidisciplinary optimisation software can contribute significantly to this communication.

However, successful application of structural optimisation software is primarily dependent on the quality and speed of the loads input on one hand and cost data/production constraints on the other. Only if the structural designer is provided with this data is he able to properly use his optimisation software.

The primary advantage of structural optimisation software is that it aids a skilled designer in gaining a feel for the design space. It should thus aid the designer in his creative task instead of distracting his attention to using the software. This requires the software to be user friendly and to have built-in features for sensitivity studies. Optimisation software requires more, not less knowledge of the design problem and the model used. It helps a skilled designer in getting to the optimum.

8. REFERENCES

1. V.B. Venkayya, Recent developments in large-scale structural optimisation, NASA Conference Publication 3031, N89-25231.
2. A. van der Neut, Some remarks on the fundamentals of structural safety, AGARD report 155, Nov.. 1957.
3. H.A. van Dulleman, Evaluation of the qualification of the structure of a passenger aircraft by analysis and full-scale testing, AGARD SMP 70th meeting, 1990.
4. Vicki S. Johnson, Optimising conceptual aircraft designs for minimum life cycle cost, NASA Conference Publication 3031, N89-25211.
5. D.D. Hufford, J.A. Ross and K.W. Hoefs, The economics of subsonic transport airplane design, evaluation and operation, SAE paper No. 710423.
6. M. Besch and J. Schuller, Influence of EFCS-System Failures on Structural Design of modern Transport Aircraft, 16th ICAS-congress, ICAS-88-1.7.2.
7. Joint Aviation Authorities, Notices of Proposed Amendment:
NPA 25C-199, issue 11: Interaction of Systems and Structures, and
NPA 25F-237: Automatic Pilot, Interaction with Structures.
8. M.H.L. Hounjet, NLR Inviscid transonic unsteady loads prediction methods in aero-elasticity, AGARD SMP, 1991, San Diego, paper 12.
9. P. Arendsen and J.F.M. Wigenraad, PANOPT USERS MANUAL, NLR-report CR91255 L, National Aerospace Laboratory, NLR, Anthony Fokkerweg, Amsterdam, The Netherlands, October 1991.
10. J.H. van der Sloot, Recent advances with the "Experimental Method Fokker: EMF" to predict Critical Loads of Stringer Stiffened Panels, ICAS paper 20.1, October 1980.
11. MECHANICA, Applied Structure, User's Guide, RASNA corp.



9 4 2 4 3 2 3

**Influence of active controls on the design process
of a large transport aircraft**

INFLUENCE OF ACTIVE CONTROLS ON THE DESIGN PROCESS OF A LARGE TRANSPORT AIRCRAFT

by

M. Molzow
Deutsche Aerospace Airbus GmbH, Hamburg
P.O. Box 95 01 09
2103 Hamburg 95
Germany

H. Zimmermann
Deutsche Aerospace Airbus GmbH, Bremen

1. Introduction

Meanwhile already the second and nearly third generation of active controlled civil transport A/C is flying and for the design engineer it has become a

business as usual

But before this happened, we all had to run through an intensive learning process because we had to realize that the interaction of the different disciplines was by far more intensive than in all other A/C designs we did before.

Having now learned, and what is sometimes more difficult, having reached the acceptance of all organizations involved that

MORE INTENSIVE INTERDISCIPLINARY COOPERATION IS NEEDED

the second problem appears

how to transfer this into daily work.

We all know in theory how it could work and what the tools to handle such problems could look like but we do not wake up one morning and the tools are there. They have to be specified, to be developed, to be validated, and in parallel, as our main task, we have to develop the A/C in time.

What was said before shows that we are in front of a very

complex technical process

and far away from the

idealized laboratory conditions

where one just starts a software and the result is the

ideal design.

It is nevertheless believed that it would not be wise to try to make this to a fully automated process, because it will be impossible to formulate all the engineering experience and expertise in an adequate manner and relationship.

So the work in this field has to be very pragmatic, and at the end of the design of several A/C of this kind there might exist an adequate tool to improve this process.

We now want to present such a pragmatic way of real A/C design under industrial conditions and in an international cooperation which does not simplify the problem at all. Fig. 1 shows the more intensive interactions of the different disciplines.

2. Items of the design process

2.1 Geometrical and structural design

The first step in the A/C configuration finding process is the geometrical design based on design criteria such as:

number of passengers/payload to be transported,
range, cruise speed, fuel consumption, manoeuvrability, controllability, commonality and maintainability.

With the geometrical design of the A/C its preliminary aerodynamic layout and performance, principles of structural components, controls, and systems are given. In a subsequent design cycle the structural design and a detailed system layout is carried out. The sizing of the structure is determined in the first step by the 1g-, manoeuvre-, gust- and ground loads which are mainly influenced by the overall aerodynamic and mass distribution, but also by fatigue loads and the flutter behaviour of the A/C for all loading cases. Outputs of this structural sizing process are among other things:

stress-, stiffness- and mass distribution.

Reliable stiffness and mass distribution are besides the steady and unsteady airforce distribution the premises for reliable loads and flutter standards. That means an interdisciplinary optimisation process has to be carried through for the elastic design of an A/C which is made much more complex by an Electronic Flight Control System equipped on the A/C. Usually the structural design is performed in relation to an official programme go ahead and in this frame a lot of significant items has to be concluded and defined as:

- o definition and order for structural long lead items as unconventional and conventional materials, forgings, ect.
- o definition and order of major aircraft systems, as computers, servoactuators etc.
- o definition of manufacturing devices (production tools)
- o time schedule for production drawings
- o manufacturing of engineering mock-ups and test specimen

By taking into account the treatment of the mentioned points and manufacturing constraints in addition, parts of the structure have to be frozen just on a preliminary basis.

Therefore the optimization process is applicable only on a reduced number of design variables whereas the knowledge underlying the design process increases with progressing time (Fig. 2) [1].

2.2 Problems with a reliable stiffness model of the A/C

The stiffness distribution for the A/C is derived iteratively from the structural sizing process. A reliable stiffness distribution for an A/C component is required timely before the freezing date of the component. This shall be underlined by a typical example:

The jig shape of an A/C wing is determined by the subtraction of the deformation induced by 1g loads for cruise conditions from the mean optimal flight shape defined by the aerodynamicists. The performance of the A/C is wrong if for such determination unreliable stiffness or aerodynamic load distributions are used.

The best representation of the stiffness of an A/C component is given by a FE-model. Usually the FE-models are established by the stress office and used mainly for the calculation of stresses of A/C components. To get a stiffness model for the A/C, the FE-models of the components have to be composed. But such a model requires the correct idealization for all load paths which is not really necessary for stress calculation of A/C components. That means the representation of a reliable stiffness distribution for the A/C is an interdisciplinary task for the disciplines: stress, loads and aeroelastics. Validation possibilities for the stiffness model are the Ground Vibration Test (GVT) and/or the Static Stiffness and Strength Tests. These tests are performed at a time when the above mentioned iteration process is already finished long time ago. That means the structural A/C design has to be frozen with stiffness distributions for the A/C components which may be more or less reliable. From this point of view structural optimisation results may fail by using them for weight saving procedures.

3.0 Electronic Flight Control System (EFCS)

3.1 System description on Airbus A/C.

Before starting to give aim and object of the EFCS a short description of some features of the flight control and the EFCS is given.

With exception of the hydraulic actuators of the rudder the actuators of all other control surfaces are electrically controlled on the concerned Airbus A/C. The input valves of the rudder actuators are connected by push rods to the yaw damper actuator outputs. These are controlled mechanically with the pedal inputs by ropes as well as electrically by the flight computer signals.

Fig. 3 shows a principle sketch of the working method of an EFCS. The angles, rates and accelerations of the aircraft are measured by the Air Data Inertial Reference Unit (ADIRU). Appropriate to the pilot command the flight control computers calculate the required control surface deflections for controlling the aircraft based on the data measured by the ADIRU which are fed back to the flight control computer and incorporated by means of con-

trol laws. The gains of the different control laws depend on speed, M-number and configuration features of the aircraft. Into the EFCS the Pitch Control, Roll Control, Yaw Control, as well as Auto Pilot, Active Control Functions and so on are integrated.

3.2 General Features of EFCS

The introduction of EFCS into the Airbus design of

A 320 and A 321
 A 330 and A 340

has to be regarded as a revolution in civil aviation.

The real layout target was in general

Handling Quality (HQ)

by

- tailoring the HQ of an A/C with reduced natural stability through systems

with the further intention to

improve the safety by protections of

- angle of attack
- load factor
- overspeed
- bank angle / roll rate
- etc.

improve the maintenance by

- using anyway recorded flight data information
- using systems anyway available for safety monitoring as information for maintenance ground staff

- reduce crew training in general but especially when changing from one type to another.

Once having decided to go this way, the EFCS offers the design engineer further chances in other domains as

general trend to reduce design loads

special alleviation devices for

- manoeuvres
- gust

augmentation for

- flutter
- vibration

improvement of ride comfort

- aircraft condition monitoring for fatigue in relation to
 - inspection interval
 - A/C life (see Fig. 4)

But as always in life, everything has more than one side. So we expected already that we would be confronted with a much more complex

System Failure Situation

which does not only have

Handling Quality Aspects

but also relevancy for

Loads
Flutter
Structures

dependent on the flexibility on the A/C.
Although the main target was to have

NO DESIGN CASES resulting from EFCS
Failures

at the end we did not totally succeed in
this philosophy.

Resulting from this experience the Airbus
partners worked out the basic philosophy
to handle systems with structural relevancy
as it is meanwhile taken over by the
JAR-Authorities in their NPA 25C-199 defining
that loads and flutter have to be investigated

- at time of failure occurrence
and
- for continuation of flight

under certain circumstances.

This led to the philosophy that the safety
factor in a failure case is defined as
function of

failure probability

respectively

time spent in failure state

(see also [2]).

All this made the already complicated design
optimization process even more complex
in general, but especially in the
early design phases where all the relevant
system information and failure definitions
are

- not available at all
- or not available in the quality to
be introduced in high sophisticated optimization
processes

3.3 Layout of the control laws

At the time being the optimization process
for the lay out of the control laws is
done for the several aircraft disciplines
step by step. That means in the first step
the control laws are established to get
attractive handling qualities for the aircraft
on the basis of a simplified aircraft model
but on a realistic concept for soft- and
hardware for the flight control computers.
The handling qualities are judged on the
Simulator with the Cooper-Harper judgement
table [3].

But the control laws must not be chosen
such that they destabilize the structural
modes and increase the loads. This must be
also valid for all the failure cases of
the EFCS. That means that the control laws
have to be proved by an interdisciplinary
design work. Finally the handling qualities,
the influence of the EFCS on loads
and aeroelastic behaviour is judged and
checked during the flight tests of the

aircraft. Therefore the final lay out of
the control laws is not easily to be
finished before the end of the flight test
period. That means the technical progress
reached with an EFCS for a passenger aircraft
must be paid by a lot of additional
tests and calculations. In the next chapters
it is shown how the EFCS influences the
aeroelastics and the loads and how the
problems had been overcome.

4.0 EFCS influence on flutter

4.1 Special features of Aeroservoelastics

The aircraft parameters are measured by
the ADIRU. In this unit pick-ups are used
which measure the acceleration at a special
point of the structure of the aircraft.
This signal contains not only the rigid
body motion but also the aircraft response
to structural degrees of freedom. This
signal is fed back to the flight computers
of the aircraft and used for the processing
of the signals transmitted to the control
surface actuators. On this way the
influence of the EFCS on flutter and dynamic
response behaviour is given.

The influence of EFCS on the flutter behaviour
is covered by aeroservoelastic calculations.
For this reason the flutter equation is
supplemented by additional terms which
describe the effect of the transfer functions
of the EFCS and the actuators and the
flutter vector is supplemented by additional
degrees of freedom with rigid control
surface modes. With this representation
instabilities of controllers and actuators
cannot be covered, because their degrees of
freedom are contained but not explicitly
extracted from the flutter equation. With
a representation of the flutter equation in
the state-space form including the degrees
of freedom of the controllers and actuators
the stability behaviour of the aircraft with
EFCS and actuators is fully described. But
in this concept the unsteady airloads
dependent on the reduced frequency cannot
be used. Instead the unsteady airloads in
the form of Padé polynomials [4] are applied.
Some special features of such an aeroservo-
elastic calculation should be mentioned:

- 1) Usually all the input data for the
flutter calculation are linear in amplitude
with exception of given nonlinearities in
stiffness which are very seldom. But the
transferfunctions of the EFCS are necessarily
nonlinear because filters, logical switches,
limiters and so on are used. Therefore, for
application in flutter calculation the
transferfunctions have to be linearized if
necessary for different working points or
the method of the "Harmonic Balance" must
be used.
- 2) The signals transmitted to the control
surfaces have time delays due to following
main effects:
 - o data acquisition
 - o analog to digital conversion
 - o data transfer
 - o signal processing

These time delays can be corrected by

the control laws. To cover the fail safe concept several computers for the flight control computer system are necessary. The different computers produce different time delays. These must be covered by calculation. Variable time delay due to computer failures may degrade the effect of active control system.

- 3) Usually a transferfunction is considered as a basic transferfunction multiplied by a gain factor and this gain factor depends on aircraft parameters as: weight, centre of gravity location, flap/slat configuration, M-number and velocity. Since the airloads for low velocities are small the gain factors are high. When the EFCS influences the flutter behaviour of an aircraft then the biggest influences may be for high gain factors, that means for lower speeds. Flutter velocities are usually expected at higher speeds. Therefore the EFCS requires difficult aeroservoelastic investigations for lower speeds and in configurations with extended flaps and slats which are not considered for normal flutter work on aircraft.
- 4) The flutter vector is approximated by a set of Eigenmodes. The actuator loads applied on the control surfaces are used in form of a series of eigenmodes. This correlates to the representation of forces to the "mode deflection method". This method leads to truncation errors by a too small number of modes used. In the aeroservoelastic calculation additional modes are required due to this effect.

The remarks 1 to 4 are considered more in detail in [5].

4.2 Influence of EFCS on flutter given by examples

Fig. 5 shows the influence of a preliminary designed EFCS on flutter behaviour. The flutter damping plots without EFCS show no instability for every degree of freedom. With EFCS the damping for the modes 1 and 5 are significantly degraded. The damping values for mode 1 already become negative for small speeds. To prevent the degradation of the flutter damping following measures ought to be introduced:

- o application of low pass filters on the signals transmitted to the actuators (fig. 6).
- o modification of control laws
- o reduction of gain factors

These measures are applied stepwise and the handling qualities have to be kept attractive in this process. After finishing this adjustment process the damping plots of the flutter results with EFCS ought to attain the order of the results without EFCS, because the introduction of an EFCS should not require design modifications on the aircraft to get a reasonable aeroservoelastic behaviour. With the low pass filter mainly the damping values of modes with frequencies higher than the

corner point (6 db) of the filter are influenced (Fig. 7).

As long as the frequencies of the rigid body modes are well separated from the frequencies of the structural modes low pass filters in the feed back circle or the normal low pass behaviour of the actuator transfer functions help to attenuate the influence of the EFCS on the flutter behaviour. The closer the frequencies of the rigid body modes and the frequencies of the structural modes are the more control law changes compared to their preliminary design become necessary to prevent the influence of the EFCS on flutter. On an aircraft like A 320 structural modes and rigid body modes are well separated in their frequencies. Therefore no measure was necessary to reduce the EFCS influence on flutter. On an aircraft like the A 340 with the fundamental structural frequencies close to 1 Hz control law changes and low pass filters were required to prevent a degradation of the damping of the structural modes by the EFCS.

Usually the adjustments of the control laws performed during the flight tests of the aircraft lead to minor changes. But for all modifications aeroservoelastic calculations must show that they do not degrade the flutter behaviour. This leads to a heavy work load during the flight tests in a tight time schedule.

5. EFCS Influence on Loads

5.1 General features

For loads purposes the A/C has to be modelled in all its important features as

Geometry
Inertia
Stiffnesses
Aerodynamic
Systems

otherwise it will not be possible to discover all the benefits, which the introduction of EFCS with active controls might have on loads, stress and through this on design weight or certain disadvantages. So it must be the target to introduce already in the early loads calculations the different control laws and study their influence on the different loads quantities to be in a position to give the systems layout people advice for changes at a time where this has not yet hardware consequences. Fig. 8 and 9 show examples for such a control arrangement.

These system changes induced from the loads experts have then again to be studied by the HQ-experts to check if there is an unacceptable adverse effect on their targets.

This is normally not the case because their optima area are relatively flat.

In several cases it was found that these changes introduced in the Simulator were not even noticed in different A/C behaviour by the pilots.

Because of the fact that during the design process the data quality improves, changes of gains and time constants are the normal

consequences resulting from the development of

Aero Data
Stiffnesses

To take already this trend into account in its effect on structural design and component weight, the loads experts will undertake

Sensitivity Studies

during which the gains and time constants will be varied and its relationship to each other changed to find out in which ranges loads might vary.

The introduction of all relevant details of the EFCS control laws and their protections in the loads calculations required to be able to handle

Non-Linearities

In some loads fields which traditionally were handled in the frequency domain, this is a major handicap which only could be overcome by very laborious and costly changes in methods and software. One example for such a problem is

Continuous Turbulence

with the
Karman Spectrum
as gust input.

5.2 Non-Failures

The introduction of the EFCS with its control laws has the tendency to make the reaction of the aircraft motion smoother during manoeuvres which leads to a loads reduction in general compared with the in former times required somewhat artificial

Design Manoeuvres

(see example in [2])

Further by introducing the different possible protections the designer has in hand another tool for tailoring an

attractive handling

together with an

acceptable Load Level
(see Fig. 10)

To a certain extent this is also the case for

Design Gusts

by introduction of, for example,

Yaw Dampers

To optimize structural weight together with other disciplines is an iteration process which has the handicaps that

o in design phases where easy and cheap design changes are possible the data quality is poor

o in design phases where data quality is good design changes become complicated and costly

It will be necessary for future designs to synchronize the different design actions more carefully than in the past.

5.3 System Failures

In general it has to be demonstrated that an aircraft of such an EFCS layout can safely be handled in a Failure State.

There might be different philosophies how this can be realized. But anyway the state of the system will be different from the

Normal Law State

and might be called

Alternate Law

or further degraded

Direct Law

These different laws produce different aircraft motions and as consequences different, possibly higher loads. This might also lead to the loss of one or the other protection.

All these different system states have to be investigated in detail also in their consequences on loads and structural design.

Reduced safety factors might be used depending on the systems failure probability.

The normal tendency is that loads in such failure states will be higher than in non-failure states.

This is easy to understand remembering that the systems were installed to improve the relatively low natural stability of the aircraft.

An unstable aircraft would have unlimited tailplane loads. The before described failure states are not failure cases in the classical sense, they better should be called Systems Degradation.

System failures with an important effect on loads and structures are "oscillating" and "runaway".

These have to be studied in their loads consequences

o at time of failure occurrence
and for
o continuation of flight

in the cases where the pilot is not able to identify those phenomena and can counteract before dangerous amplitudes are reached.

The last condition can lead to a very severe problem for Static Design and Fatigue Design too, because the NPA 25C-199 requires for static design the superposition

of the failure induced loads with those resulting from the normal non-failure design conditions.

Even if the failure probability is such that a safety factor equal to one is justified, this problem cannot be solved without consequences either for the system or for the structure.

In the figures 11 to 13 oscillatory failure cases are described. The allowed surfaces deflection diagrams show a concentrated overview of the criticality of an oscillatory failure in relation to structural design loads:

Solid Line:

Envelope of max. (allowable) surface amplitudes versus frequency $> 1,5$ Hz, which produce the Design Loads on all structural components and stations, from all investigated flight and mass conditions, derived from a full dynamic analysis

Dashed/Dotted Line:

Actuator Performance Curve, i.e. max. possible surface deflection output amplitudes versus frequency, only one actuator can perform loaded while the standby actuator is in damping mode.

If the output signal is non-sinusoidal an energy factor can be applied, relating the energy contents of the non-sinusoidal output signal to a pure sinusoidal one (First Harmonic Performance).

Servo-Loop Failure:

Oscillatory Failure of electronic/hydraulic servo-loop. Mainly: D/A - A/D converters.

Computer Failures:

Oscillatory Failures of electronic elements or due to gain variations, occurring upstream of the actuators and influencing their command channels.

The repercussion of this type of failure can be cured in most of the cases by an adequate low-pass filtering in the command channels.

Criticality Conditions:

A critical Oscillatory Failure condition at "Time-of-Occurrence" is indicated, if a "resonance" peak of the Allowable Surface Deflection Curve (solid line) crosses the Actuator Performance curve. In this case a specific Design Load on a structural component is exceeded by a certain margin.

EFCS-Working Area:

Oscillatory Failures in the EFCS working frequency band ($< 1,5$ Hz) are detected by the Position Monitoring System with a threshold setting, so that Design Loads are not exceeded.

6. Active Control Functions

On an aircraft fully equipped with an EFCS it is rather simple to install additional Active Control functions as already mentioned. These can use already available systems and controls just adding some sensors and software packages and possibly pressure accumulators to reach higher deflection rates.

Depending on the individual design situation of an aircraft as

- o gust critical wing design like an A/C as Airbus A 320
- or
- o Manoeuver critical wing design like an A/C as Airbus A 330/340

it might become attractive to add to the already installed control laws

Load Alleviation Functions (LAF)

Fig. 14 shows a scheme of such a Gust Load Alleviation (GLA) with the target to reduce Gust wing bending to the maneuver level.

The installation of

Manoeuver Load Alleviation (MLA)

is even simpler because the high control deflection rates of the LAF are not necessary. Nevertheless also all these functions have to be studied in relation to their influence on other disciplines also here especially on their effect on

Handling Quality

in non-failure and failure state. Another example is a function for improving the passenger ride comfort of an A/C called "Comfort in Turbulence" (CIT). Fuselage modes with small participation of lifting surface vibration may be less aerodynamically damped, mainly for long and relatively slender fuselages. In heavy turbulent flights the aircraft might vibrate in the fuselage modes with frequencies which mainly degrade the flight comfort in the forward and aft fuselage sections. Fig. 15 shows the principle scheme for a CIT function which controls the lateral fundamental fuselage mode by the rudder. The acceleration pick-up is installed at a location on the front fuselage. The structural filters and the phase compensation are shown in the feed back circle. The rudder is activated for a necessary vibration angle of the rudder of $> 0,07^\circ$. To prevent a degradation of the effectiveness of other systems with higher priority the rudder angle activated by the CIT is limited to 1° . Fig. 16 shows the necessary design work including the flight tests to get certification. For certification it has to be substantiated that the CIT-system in all its failure cases does not degrade the flutter and does not increase also dimensioning loads. Fig. 17 shows the increase of modal damping for the symmetrical fundamental fuselage mode which is controlled by the CIT-function using the elevator as movable device.

7. Conclusion

The high complexity of an active controlled civil transport aircraft design with its multiple interactions between the different disciplines was presented.

It was highlighted that in future design of this kind different design procedures have to be established with the target

- o to reduce the dominance of one discipline by a multidisciplinary optimization process to ensure an overall aircraft optimum.

This has the consequence that

- o the data availability in a certain quality, namely

Stiffnesses
 Aero Data
 Systems Data

must be better synchronized with the needs of the user of these data, namely

Handling Quality
 Systems
 Loads
 Flutter
 Structures

and cost functions are introduced in the beginning of the design work to ensure a balanced design.

It is the firm belief of the authors that already this would be an important step forward.

Active Control systems are rather easily capable of being integrated by having in mind to use signals from additional sensors distributed over the A/C than are available from the ADIRU.

There are some doubts that all these relations and interactions in real aircraft design can be replaced one day by a totally automated process but certainly more parts as usually today have to be put into a process chain to improve quality and safe design time.

To our opinion, the real problem is not only to solve the technical problems, the more time consuming task will be to change behaviour of people involved.

8. References

- [1] J. Sobieszczanski-Sobieski: Multidisciplinary Optimization for Engineering Systems: Achievements and Potential Proc. of an Internat. Seminar, Organized by DLR, Bonn, June 1991, Lecture Notes in Engineering, DLR 47
- [2] M. Molzow; R. Moebest: The Interference of Flightmechanical Control Laws with those of Load Alleviation and its Influence on Structural Design. Conference Proceedings No. 470
- [3] G.E. Cooper; R.P. Harper, Jr.: The Use of Pilot Rating in the Evaluation of Aircraft Handling Qualities. NASA TN D-5153, 1969
- [4] R. Vepa: On the Use of Padé Approximants to Represent Unsteady Aerodynamic Loads, AIAA 14th Aerospace Sciences Meeting, Washington, D.C. Jan. 26-28, 1976
- [5] K. König: On the New Quality of the Flutter Problem due to Coupling of Structure and Electronic Flight Controls in Modern Large and Flexible Civil Aircraft. To be presented on: International Forum on Aeroelasticity and Structural Dynamics 1993 Strasbourg, 24.-26. May 1993

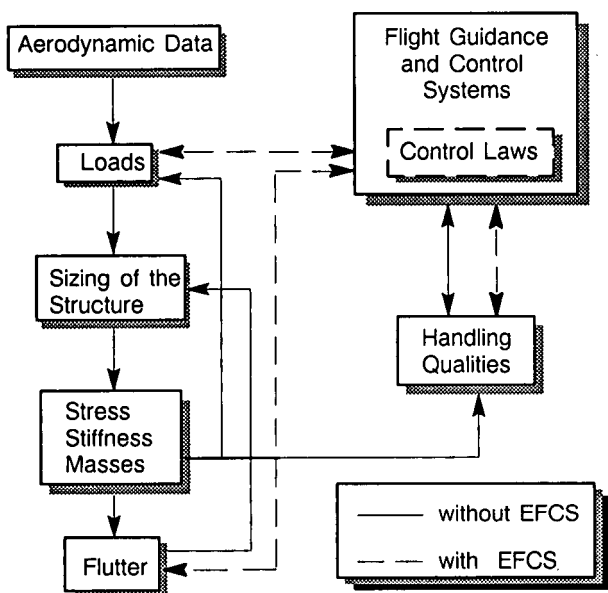

Fig 1: Aircraft Design

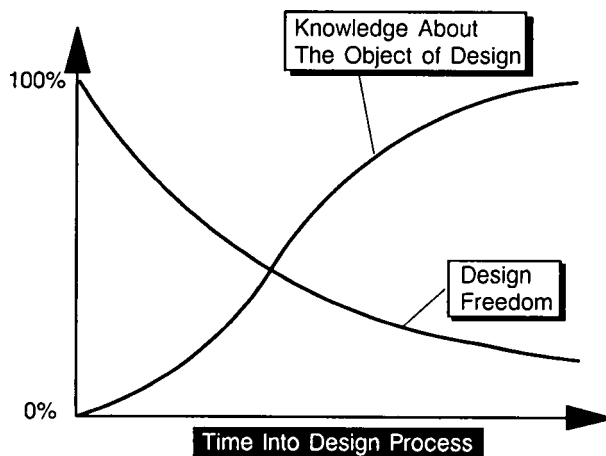

Fig. 2: Paradox of Sequential Design

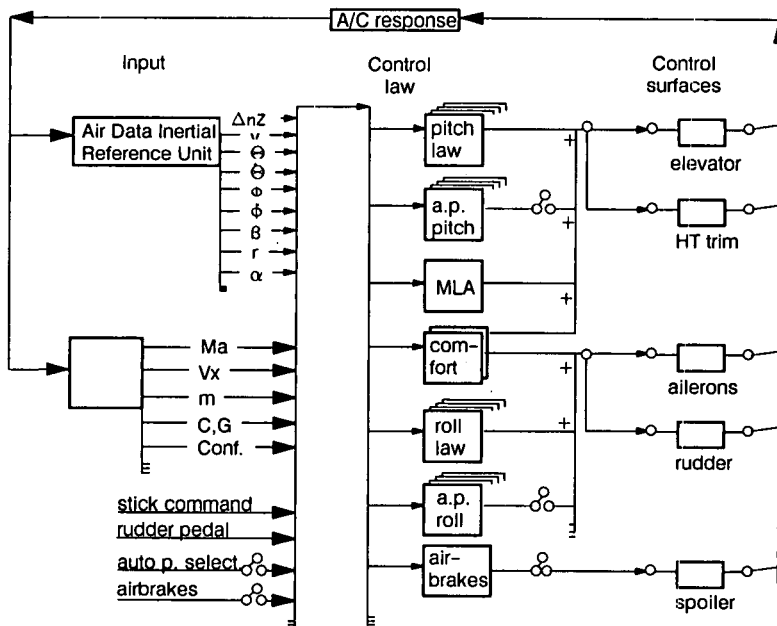

Fig. 3: Simplified Electronic Control Circuit

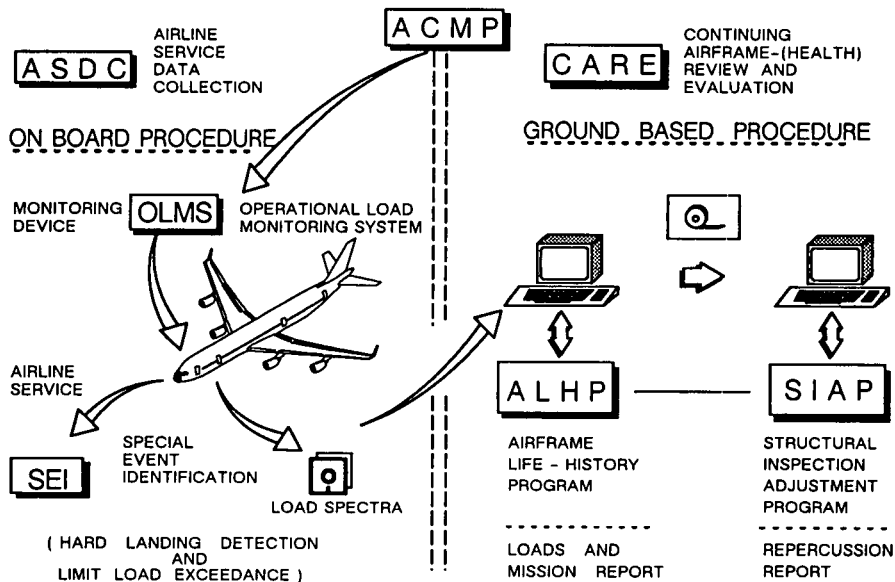

Fig. 4: Airframe Condition Monitoring Procedure, ACMP

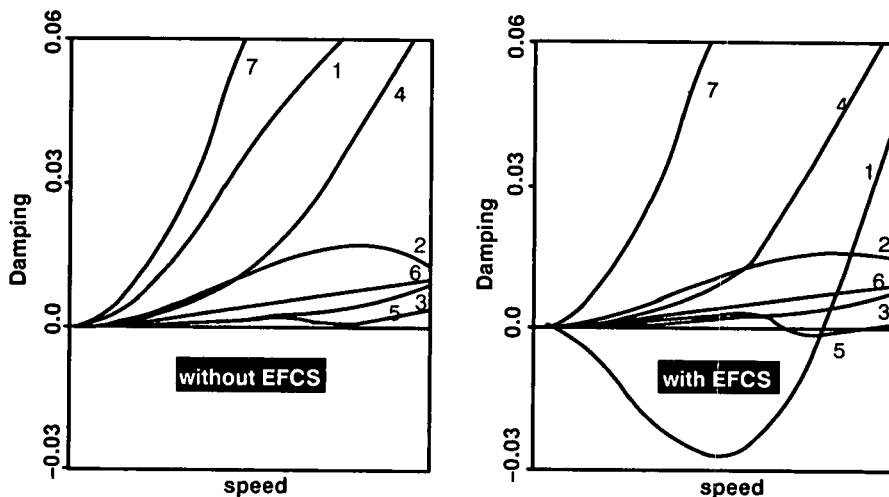

Fig. 5: Comparison of Flutter Calculation Results With And Without The Effect of EFCS

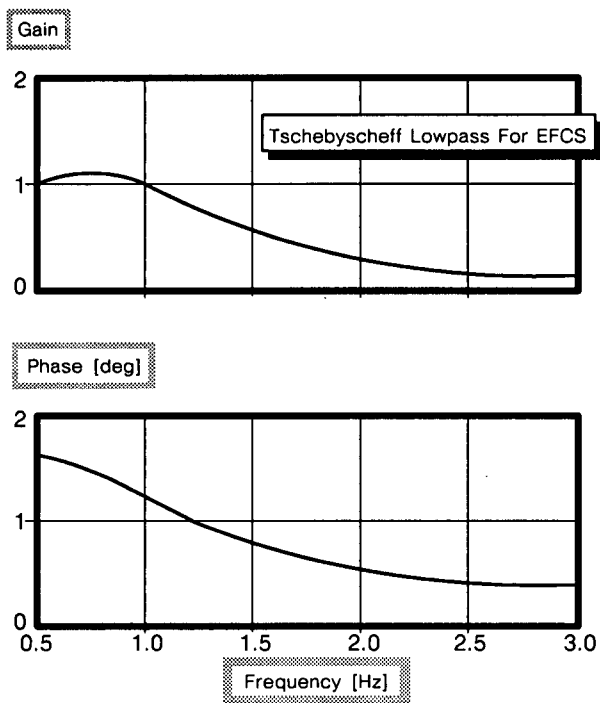

Fig. 6 Low Pass Filters Attenuating The Signals For The Control Surface Actuator

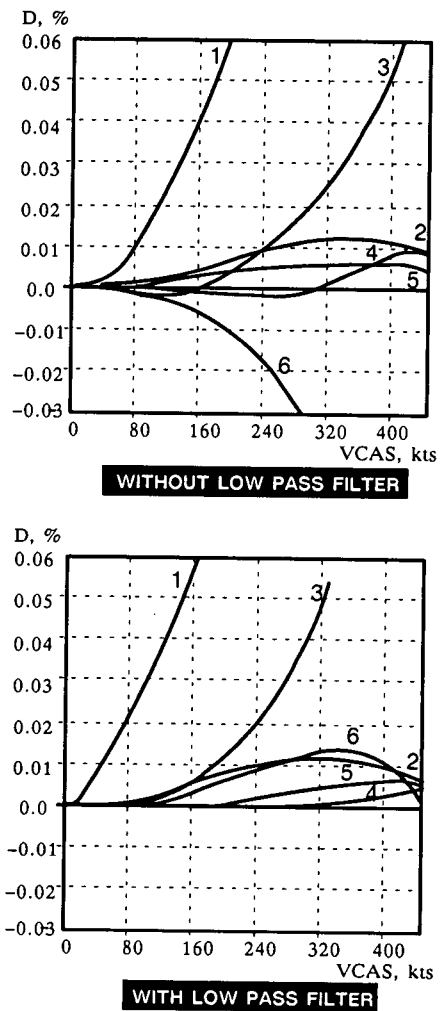

Fig. 7 Influence of Low Pass Filters on The Mode Damping of Flutter Calculation

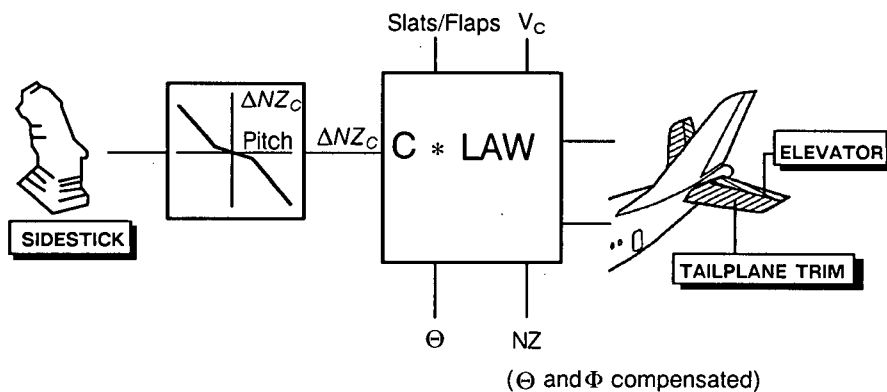

Fig. 8 Pitch Control Arrangement

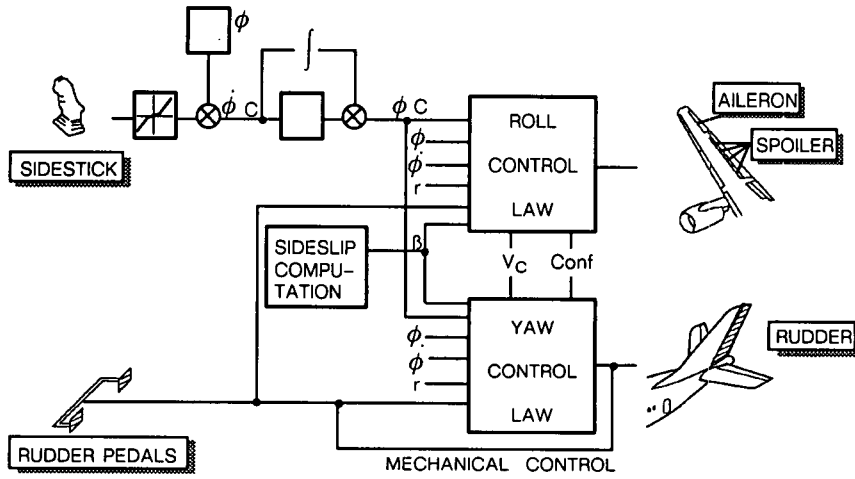

Fig. 9 Lateral Control Arrangement

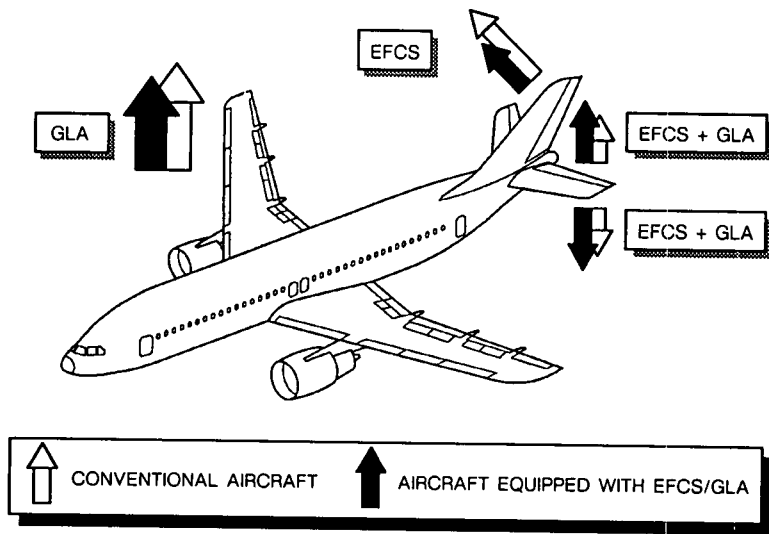

Fig. 10 Effects of Fly-By-Wire System Technology on Structural Loads

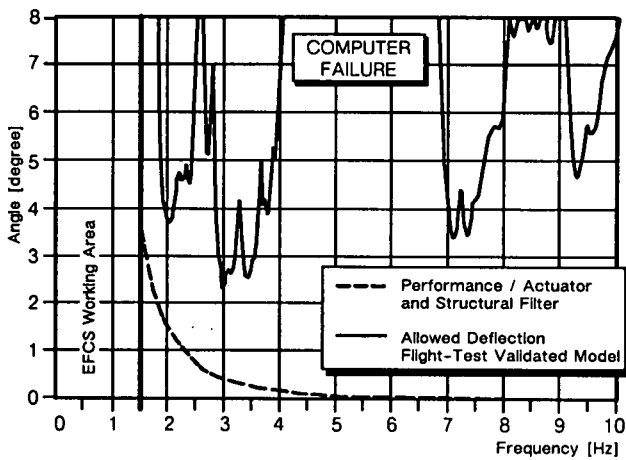

Fig. 11 Rudder-Oscillating Allowed Surface Deflection Acceptable by Static Loads Envelope

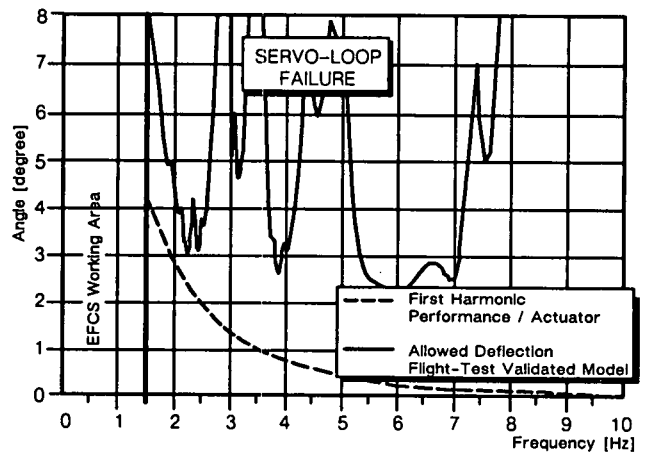

Fig. 12 Antisymmetrical Inboard Aileron-Oscillating Allowed Surface Deflection Acceptable by Static Loads Envelope

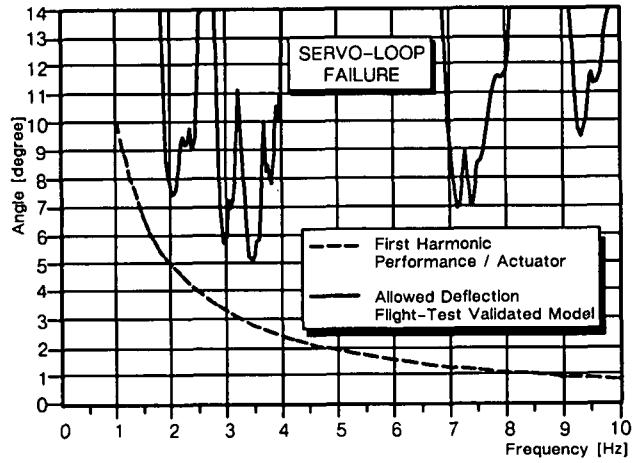

Fig. 13 Harmonic Antisymmetrical Inboard Aileron-Oscillating Allowed Surface Deflection Acceptable by Static Loads Envelope

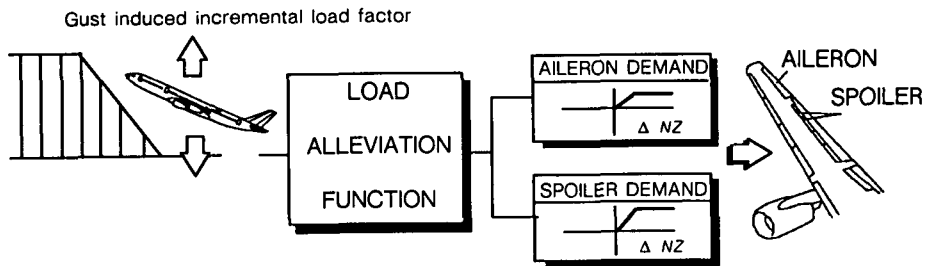

Fig. 14 Gust Load Alleviation Function

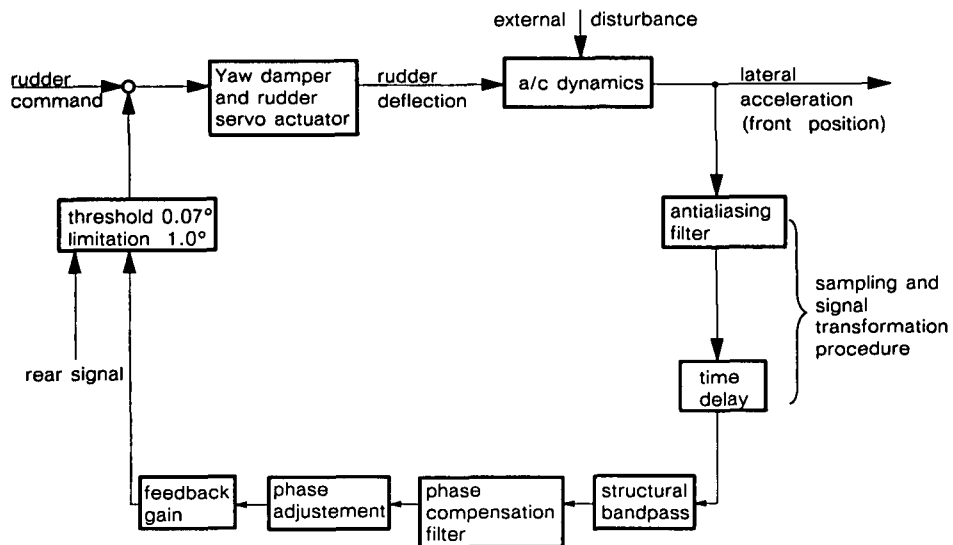

Fig. 15 Principle Scheme For Lateral CIT

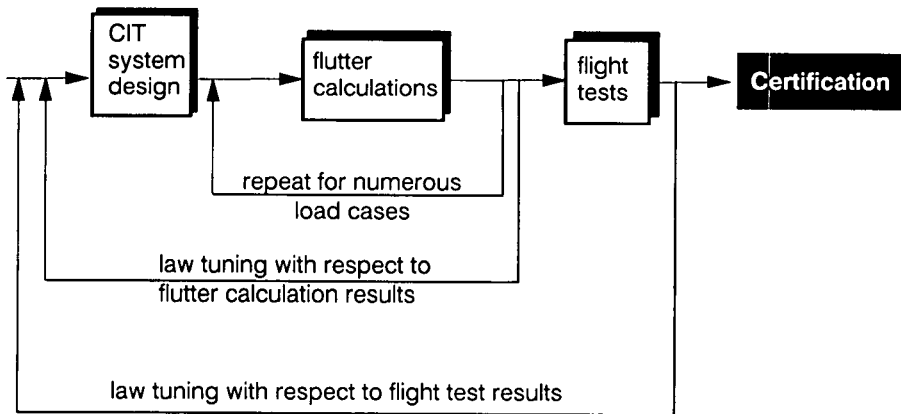

Fig. 16 CIT Development Approach

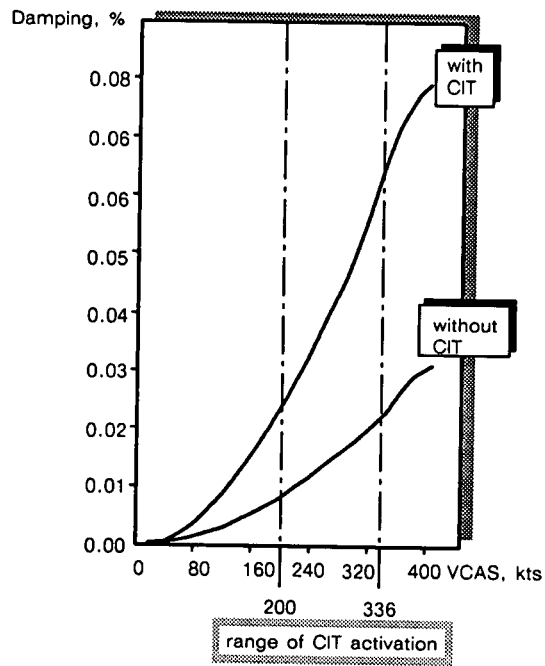

Fig. 17 Modal Damping Increase For Vertical CIT

CURRENT AND FUTURE DESIGN METHODS FOR LARGE TRANSPORT AIRCRAFT

by

J.P. Giesing, G.T.J. Tzong and B.E. Schofield
McDonnell Douglas Aerospace and Douglas Aircraft Company
McDonnell Douglas Corporation
3855 Lakewood Blvd
Long Beach, CA 90846
United States

ABSTRACT

Current aircraft industry design practices produce high quality, safe and affordable aircraft. However, future advanced and integrated methods offer the opportunity to significantly reduce the cost and development time of aircraft designs. This paper presents an overview of the current design process and an example for subsonic transport wing box design. It also describes a future process which is presently being implemented at the Douglas Aircraft Company, i.e. the Aeroelastic Design Optimization Program (ADOP), and its application to a similar subsonic transport wing. Specifically, stress and flutter are optimized and compression surface buckling and tension surface damage tolerance are integrated. Finally, the future direction of ADOP will be outlined which includes integration of aeroelastic loads, durability and damage tolerance and concurrent structure and active controls optimization.

CURRENT DESIGN PROCESS

OVERVIEW

The current structural design procedure for most aerospace companies is illustrated in Fig. 1-a as a process done in a series that is iterated several times. Each iteration requires on the order of six months to a year to complete and requires data transfer across technical, political and sometimes geographic boundaries at each step in the process.

The leader in each discipline must have enough experience to know what input data is needed from other disciplines, how to complete his own analysis and what output data is needed for the next step in the operation. Most of the time, different models of the aircraft structure and aerodynamics are developed at each step of the process. This is done for several reasons: 1) different assumptions and model fidelity are required, 2) computer code formats are different and, 3) each discipline wants to get started without waiting for someone else's model. The drawbacks, of course, are that: 1) data input is sometimes duplicated, 2) errors and inconsistencies can develop among models, and 3) accuracy levels are not consistent among the various disciplines.

During the initial design process, as opposed to the final check out, only preliminary data is available and, therefore, used. Every discipline is working with whatever data is available to that discipline at a particular point in time. Many times new data arrives midway through an analysis for a particular discipline but usually this new data is put on hold until the next iteration. The items that influence data changes are: 1) updated input from other disciplines, 2) configuration changes due to changes of mission or airline customer feedback, 3) cost and performance enhancements, 4) and completion of wind tunnel and structural tests. Obtaining the data necessary to complete an analysis or design in a particular area is usually the

controlling factor and main element that lengthens cycle time and increases cost.

Usually the structural design is completed before the drawing sign-out loads are available. This is due to the long lead time required for wind tunnel tests and critical load analysis and selection. Also, the design is usually complete even before the structural panel tests are done. The process is to issue the drawings and then check them after the fact.

If a negative margin is found in the structure or the aircraft has a flutter or durability and damage tolerance problem, the problem is corrected and the drawing recalled and fixed. The positive margins, within limits, are usually left alone, because of the cost of trying to optimize every structural element, until a weight saving exercise is called for.

Details of the process of wing sizing will be given to illustrate current industry practices. Specifically, the methodology for: 1) compression surface optimization for rib and stringer spacing, 2) tension surface design for damage tolerance, 3) compression-bending shear interaction, 4) load definition, and 5) flutter analysis will be discussed.

WING SIZING METHODOLOGY

Compression Surface Optimization of Rib and Stringer Spacing

In order to keep overall wing weight to a minimum, it is important to establish optimum stringer and rib spacing. If the spacings are arbitrarily set too large for the compression cover, in an effort to reduce part count and subsequently cost, a severe weight penalty can occur which will ultimately jeopardize the number of aircraft sold due to inadequate performance when compared to competitor aircraft. Therefore, to assure least weight, the following optimization procedure is performed:

1) Define wing compression cover loads (elastic axis) -- The average in-plane load intensity (P_1 lbs/in) in the compression cover, shown in Fig. 2, is determined along the wing elastic axis (defined half way between spars) using the wing bending moments, wing box chord (rear spar to front spar normal to elastic axis), and average box depth.

2) Determine cover allowable compression stress -- for the compression surface, Douglas Aircraft Company has developed a compression panel optimization program [1] based on the classical optimization assumption that minimum compression panel weight is obtained when the applied stress ($\sigma = P/A$) is equal to the general instability stress $\sigma = \pi^2 E_{II}(L/\rho)^2$ and the individual plate element instability stress $\sigma = k\eta E(t/b)^2$. The program optimizes the stringer cross-sectional shape for a given stringer spacing, rib spacing, and stiffening ratio, A_{II}/A_{sk} . A practical stringer depth (between 2"-3") is employed to avoid torsional instability, keep the section neutral axis as close to the skin as possible, and maximize stringer extrusion strength values. The program is used to develop a family of panel

weights versus load intensity curves for defined skin/stringer material, stringer spacing, rib spacing, and stiffening ratio.

The stiffening ratio is set at 0.50 in the early design phase to assure that sufficient skin thickness and subsequently torque box *GJ* is available to prevent wing flutter and to assure sufficient stringer area is available for damage tolerance. From a pure compression panel weight optimization, lighter weight can be obtained at higher stiffening ratios (minimum weight at 1 to 1.5 depending on the stringer shape) if stringer depth is not constrained. However, this can lead to flutter problems determined at a later time and may produce stringer depths that lead to non-optimum designs when all factors are considered.

The future optimization process, ADOP, will allow the skin-stringer stiffening ratio to vary to maximize the compression allowable while still maintaining the proper flutter safety margin and stringer depths. There is more than one way to prevent flutter and setting this ratio to 0.5 may not always be the most efficient way to do it. Thus, although a very good rule of thumb, some improvement may be made and this improvement will be available early in the design.

3) Determine upper cover weight -- The process is simply to divide the wing into spanwise sections or panels, say six of them, calculate the average running load, P_1 , per panel from Figure 2, and determine the incremental panel weight, W_c from Fig. 3.

4) Determine lower cover weight -- For the tension surface, the allowable stress is limited by damage tolerance requirement (discussed below). For preliminary design, $F_t = 52,000 \text{ psi}$ is used for aluminum alloys. Panel weight can be incrementally determined from the weight per unit area based on stress and the average running load, $W_c = 144\rho P_1/F_t \text{ (lbs/ft}^2\text{)}$.

5) Determine rib weight -- Rib weight is generally about 30 percent of the total cover weight (not including spar caps). This high weight ratio is due to the fact that a large percentage of transport aircraft rib weight is driven by externally applied forces such as flap and control surface loads. When these factors are discounted, rib weight required to support the cover is about 5 percent of the total cover weight. Rib strength and stiffness requirements must be accounted for in the final design, but in practice, minimum gauge will usually satisfy the requirements for ribs. Based on this assumption, rib weight is obtained as follows:

$$W_{Ri} = A_{rav} \bar{t} n \rho \quad (1)$$

where A_{rav} is the average surface area of ribs \bar{t} is the rib thickness; n is the number of ribs; and ρ is the weight density.

6) Determine panel/rib weight -- The overall weight is determined by summing the cover weights and rib weights. This weight can be plotted for various panel length and stringer spacings (Fig. 4). From the figure, 6-inch stringer spacing is the lightest weight at a rib spacing of about 35 in. Actually stringer spacings less than 6-inch are more optimum (about 5.3 inch). However, this spacing is too small for shear clip installation.

Based on the optimum values for rib and stringer spacings, a wing structural arrangement drawing (for example, see Figure 5) is created that first defines hardpoints for control surface hinges, flap hinges, pylon attach structure, and slat track location. Based on these fixed rib locations, ribs are spaced

approximately to the optimum rib spacing. Stringers are then spaced near the optimum spacing.

Tension Surface Design for Damage Tolerance

The wing structure is required by the FAA to be damage tolerant to insure that if fatigue, corrosion, or accidental damage occur within the operational life of the airplane, the remaining structure will withstand reasonable loads without failure or excessive deformation until the damage is detected. Although not strictly required by FAA regulations, the wing should be designed for two-bay crack capability [2] so that the critical crack sizes are large enough to allow an inspection program that requires detecting these cracks safely with comfortable repetitive inspection intervals. Specifically, the lower wing surface must be able to arrest a two bay crack (broken stringer and two adjacent skin bays) at limit load. This means that the two bay crack is rendered non-critical and will not fast fracture.

During preliminary design, the lower surface stringer spacing and shape are set nearly the same as that for the upper surface and the ratio of stringer area to skin area is set at 0.5 to assume maximum allowable stress is obtained. A two-bay crack residual strength analysis is then performed to obtain the allowable stress level. Usually this level is the most critical compared to crack growth life, negative 1-g buckling, or material allowables.

The future design method ADOP accounts for the two-bay crack allowable in the optimization process as the ratio of stringer area and skin area changes and will not fix the ratio of stringer to skin area to a specific number.

Fatigue and crack growth life is also analyzed for the lower wing surface but usually after the design is complete. This analysis determines the inspection threshold and interval. The threshold is half of the life determined by test or a third of the life obtained by analysis but no greater than half of the aircraft life. The inspection interval is equal to half the time interval between when a detectable crack appears and when it becomes unstable. In some instances, unacceptable values of the threshold and interval dictate an allowable stress that is lower than the residual strength value in which case the design is beefed up.

Compression-Bending-Shear-Interaction

The margins of safety are calculated using an interaction equation that combines the various stress or buckling states. For instance, the compression surface margins are calculated from the following semi-empirical equation

$$(R_c + R_b)^n + R_s^m = 1.0 \quad (2)$$

where n and m are determined empirically and R_c , R_b and R_s are the ratio of actual stress over the allowable stress for compression, bending (modulus of rupture) and shear respectively.

The compression allowable P_{ca} is usually found by combining panel test results with the Johnson-Euler formula. The column fixity factor c (1.0 for simple support, 4.0 for built in) is usually taken as no more than 1.5 for this formula. The optimum stringer rib design discussed above usually places the stringer (plus effective skin) in the short-column range of the Johnson-Euler formula.

This compression surface interaction formula is semi-empirical but has proven successful for the DC-9, and DC-10 aircraft that have millions of safe flight hours. The tension surface uses principal stresses since buckling is not involved. The future design method, ADOP, can use these formulas or others, such as von Mises as the designer wishes.

Load Definitions

Internal structural loads are required to size the structure. However, these loads are a direct function of the aeroelastic external loads which are, themselves, a function of the structural stiffness.

The structural model used for loads (and flutter) is usually a beam stick elastic axis for subsonic transport wings. Linear Doublet Lattice aerodynamics [3,4], corrected using wind tunnel data, are used for the gust loads and flutter analysis. A nonlinear semi-empirical model is used for maneuver loads which incorporates wind tunnel data. As stated in the overview, drawing sign-out loads are usually not available at the time of design, and thus preliminary or advanced design loads must be used. These loads may not be based on up-to-date wind tunnel data.

The process to obtain drawing sign-out loads is outlined as follows. First, compute the elastic-to-rigid ratios for the stability and control aerodynamics coefficients. The rigid coefficients are usually obtained from wind tunnel tests. These elasticity corrected coefficients are then used to obtain trimmed conditions for static maneuver loads cases which range over the entire flight envelope of velocity, load factor, altitude, c.g. and weight. They are also used for abrupt pitch, roll and yaw maneuvers. The rigid wing tunnel data are also used to correct the unsteady doublet lattice method for use in PSD and discrete gust analysis as was mentioned above.

A first pass at critical load selection is made at this time where obvious cases are eliminated reducing the number of cases to several thousand.

The second step is to perform distributed maneuver loads analyses for the various aircraft components and to perform a second pass at critical load selection based, for the most part, on interaction diagrams (Bending/Torque, Shear/Torque, Bending/Shear). The cases that lie on the outer extremities are selected as candidate critical cases reducing the number of cases to about a hundred.

Gust loading and taxi analyses are also performed and produce an additional set of candidate critical load cases using the interaction diagram approach.

The final candidate load cases are then used to calculate internal loads. At this point the actual critical cases for all wing parts can be identified and used to check the design and resize the structure if needed.

Flutter Analysis

A V-g method is generally employed using empirically corrected Doublet Lattice aerodynamics and a beam elastic axis structural model. Mass, inertia and cross products of inertia are employed in the model analysis. These modes are eventually corrected using Ground Vibration Test (GVT) results after aircraft roll-out. Obviously, the GVT does not impact the aircraft design but is used only as a safety check after the fact.

The entire flight envelop is cleared for flutter with a margin of 15%. If a flutter deficiency exists anywhere, a stiffness increase requirement for wing or pylon is obtained (usually by the trial and error method) and sent to the designer who redesigns the wing to produce the required stiffness. Sometimes, if only a small corner of the flight envelope or fuel state causes a problem the aircraft can be "placarded" to reduce V_c and V_d and thus eliminate the problem, without changing the structured design.

Generally for high aspect ratio wings, a beam stick structural model is used. Modes are easy to obtain once estimates of EI , GJ , mass and inertia along the span are made. Making these estimates from finite-element models, however, can be time consuming. For low aspect ratio wings, plate theory must be used. In the future design method, ADOP, only one structural model is used for all analysis and design. This can cause an increase in cycle time because the finite-element model may be detailed and require more time in the modal analysis. But it is felt that this inconvenience is more than compensated for by the benefits obtained using one accurate structural model.

FUTURE DESIGN PROCESS DESCRIPTION

Because the current structural design procedure (Fig. 1-a) does not simultaneously consider all disciplines such as stress, sizing, flutter, loads, etc. it requires a large amount of time and man-power to complete. Specifically, each design cycle takes longer, more cycles are needed to reach an optimum, and numerous meetings and discussions are required. An aeroelastic design optimization program, ADOP, is being developed at the McDonnell Douglas Corporation to reduce cycle time, improve the quality and accuracy of the final design and reduce the number of design cycles (Fig. 1-b). This program will reduce the elapsed time required for drawing sign-out and rework of designs and their associated delays. Ultimately, cost, schedule, performance and quality will be improved.

ADOP PROGRAM STRUCTURE

ADOP integrates different analysis and design disciplines, uses one analysis model, and optimizes the model to achieve a minimum weight while simultaneously satisfying structural performance requirements. Compared with different models used by diverse disciplines and incomplete weight minimization in the current design process, the advantages of using ADOP are already seen.

ADOP is developed for efficient static, dynamic, and aeroelastic optimization of large finite element structural models. The program is modularized by discipline and logical tasks. Current modules include:

- o Finite element bulk data translation;
- o Matrix abstraction computations;
- o Static strength;
- o Large order eigenvalue and eigenvector extraction;
- o Fully stressed design;
- o k and p-k method flutter analysis;
- o Dynamic transient response;
- o Design sensitivity calculation;
- o Design variable linking;
- o Multidisciplinary optimization.

The modules are then linked together through a master control program (ACL; ADOP control language) [5] and data base management system ADACS (ADOP disk and core system) [6]. ADACS uses a dynamic memory and file allocation

scheme to store and retrieve data to allow for the manipulation of very large arrays associated with large structural models. ACL is developed to access discipline modules, perform matrix operations, and establish logical looping and branching. A graphical interface program is also implemented to perform intermediate and post processing associated with the analysis and design optimization. Case control logic is established to guide analysis and design flow in optimization and access appropriate discipline modules.

Presently, multidisciplinary design in ADOP optimizes aircraft structures subject to:

- o Stress and strain constraints;
- o Displacement constraints;
- o Modal frequency constraints;
- o Flutter constraints.

Static strength optimization ensures that the stresses and strains are below the allowable values and the structural stiffness meets the deformation requirements subject to the design loads. Frequency constraints prevent the structural vibration modes from falling into a specific range of frequencies. Flutter requirements sometimes dictate the structure's stiffness. Thus, the aircraft structural size needs to be distributed properly to avoid flutter. In an ADOP optimization iteration, structural response such as stress, displacement, vibration frequency and flutter speed will be evaluated. Violated constraints are identified and the structure is resized with those response sensitivities. The program then selects a new structure which tries to minimize weight and satisfy the violated constraints. The iteration continues until all constraints are satisfied and the weight variation is stationary.

FINITE ELEMENTS AND DESIGN VARIABLE LINKING

The finite elements that can be designed in ADOP and their design variables are:

- o Area of 2-node rod;
 - o Area and moments of inertias or real dimensions of beam;
 - o Stiffness of linear and torsional springs;
 - o Thickness of TRI3 orthotropic membrane and plate-shell;
 - o Thickness of QUAD4 orthotropic membrane and plate-shell;
 - o Thickness of quadrilateral shear panel;
 - o Ply thickness and one orientation of composite membranes;
 - o Mass and offset of lumped mass element; and
 - o Stiffness of general flexibility/stiffness element (GENEL).
- Rigid elements and multiple point constraint capabilities are also implemented to provide modelling flexibility.

In the optimization process the number of design variables is limited by computer resources. It is impractical and unnecessary to retain each element in a large structural model as an independent design variable, since in portions of a structure a simple relationship of structural properties can be defined using the previous design experience and manufacturing constraints. Design variable linking [7] is accomplished by representing finite element sizes by a few design variables and a shape function as follows:

$$l = RD \quad (3)$$

where l is the element size vector, R is the ratio between l and the independent design variables D .

In ADOP, the features in design variable linking include:

- o Free and fixed design variables for the same group;
- o Constant, linear and bilinear shape functions; and

- o User input variations for high order functions.

A global design variable linking is installed to complement the basic design variable linking. The technique allows users to define the relationship between design variables, so that, for example, a composite wing skin divided into several panels has ply thickness as design variables for each individual panel but has only one global orientation. Therefore, during optimization the ply thickness of each panel varies independently but all panels on the wing skin have to rotate together like a rigid surface. This can be resolved by equating the orientations of all panels to a representative orientation through the global design variable linking.

STATIC DESIGN TECHNOLOGIES

ADOP uses the "fully stressed design" technique (FSD) to resize finite elements and obtain a nearly optimum solution for static strength before starting numerical optimization. This reduces the number of iterations in the optimization. The ADOP static design and analysis technologies include:

- o Point (aeroelastic), pressure, thermal, inertia, and combined loads;
- o Fully stressed design (FSD) with design variable linking;
- o Compression panel buckling criterion;
- o Tension 2-bay crack criterion in durability and damage tolerance;
- o Stress and strain design criteria:
 - Mises-Hill stress,
 - Principal stress and strain,
 - Maximum shear stress and strain,
 - Tsai-Wu stress, and
 - Truncated maximum shear strain;
- o Displacement and stiffness design criteria; and
- o Analytic design sensitivity calculation.

Compression panel buckling [1] and tension two-bay crack criteria [2] are used for metallic structures in both fully stressed design and strength optimization. All possible buckling conditions including skin buckling between stringers, overall stringer buckling, stringer crippling, and the torsional stability of a skin-stringer combination are checked. The two-bay crack criterion requires that if a stringer and the skin in adjacent bays are broken, the crack be arrested by the stringers at both ends of the two bays to maintain the structural integrity. In the optimization procedure, the design sensitivities of panel buckling and two-bay crack stress allowables are included and the allowables are updated according to the new element sizes in each iteration. The panel buckling and two-bay crack stress allowables are also used in the interaction equation (Eq. 2) and damage tolerance design in the current design process as discussed previously. However, there is no update of these allowables in the current process until all disciplines are checked out and a new iteration begins.

The stress, strain and displacement constraints can be used in the optimization. They are written as

$$G_s = \frac{x}{x_0} - 1 \leq 0 \quad (4)$$

in which x may be the normalized von Mises equivalent stress, strain in a particular direction or a specific displacement component. x_0 is the corresponding allowable value.

The displacement design sensitivities are computed using the direct gradient method as

$$\underline{K} \frac{\partial \underline{u}}{\partial D_1} = \frac{\partial \underline{p}}{\partial D_1} - \frac{\partial \underline{K}}{\partial D_1} \underline{u} \quad (5)$$

where $\partial \underline{u}/\partial D_1$ and $\partial \underline{p}/\partial D_1$ are the displacement and load sensitivity vectors, respectively. The load design sensitivities are only present for loads associated with structural sizes such as thermal, inertia and static aeroelastic loads. (Aeroelastic loads design sensitivities are being developed and will be discussed later.) $\partial \underline{K}/\partial D_1$ is the design sensitivity of stiffness matrix.

The constraint gradient of the Mises-Hill criterion, for example, is expressed as

$$\frac{\partial G_\sigma}{\partial D_1} = \frac{1}{2\sigma} \left[\left(\frac{2\sigma_x}{S_1^2} - \frac{\sigma_y}{S_1^2} \right) \frac{\partial \sigma_x}{\partial D_1} + \left(\frac{2\sigma_y}{S_2^2} - \frac{\sigma_x}{S_1^2} \right) \frac{\partial \sigma_y}{\partial D_1} + \frac{2\tau_{xy}}{S_{12}^2} \frac{\partial \tau_{xy}}{\partial D_1} \right] \quad (6)$$

where σ_x , σ_y and τ_{xy} are the element normal and shear stresses; and S_1 , S_2 and S_{12} are their corresponding stress allowables.

The generalized interaction failure criterion for the compression surfaces (Eq. 2) and its constraint gradient can also be written in the forms of Eqs. 4 and 6, respectively.

MODAL DESIGN TECHNOLOGIES

An accurate and efficient modal analysis is essential to various dynamic evaluations of structures. Compared with using the beam-stick representation of aircraft for modal and flutter analysis, a full finite element aircraft model is more appropriate because it can address the chordwise deformation, accurately represent the structural stiffness, and eliminate any confusion in model conversion between the finite element and beam models. Today, analysis of large unreduced structural models is possible with powerful computers and advanced computing techniques. ADOP has two large-order modal analysis methods, the block Lanczos method [8,9] and accelerated subspace iteration [10]. Both methods are designed to directly extract eigenvalues and eigenvectors of large structural models. The numerical problem caused by the return of converged eigenvectors is resolved by using a selective Gram-Schmidt orthogonalization.

The full modal analysis methods require better modelling practices than the simple beam model. ADOP automatically diagnoses and restrains most singular degrees of freedom due to the use of rank deficient elements. However, singularities (unrestrained by ADOP and ignored in the static analysis) due to improper modelling need time to correct. The benefits of using the full finite element model far exceed the additional time paid for this correction because model conversion required in the current design process is not needed and higher quality results are generated.

The frequency constraints allow engineers to restrain the structural vibration modes from falling into a specified range of frequencies. The constraints can be written as

$$G_U = \frac{\lambda_i}{(2\pi f_{up})^2} - 1 \quad \text{and} \quad G_L = 1 - \frac{\lambda_i}{(2\pi f_{low})^2} \quad (7)$$

in which f_{up} and f_{low} are the upper and lower bounds of the frequency and λ_i is the corresponding eigenvalue.

For eigenvalue λ_i with m multiple roots the design sensitivities are solved using

$$\left(\underline{\Phi}_m^T \frac{\partial \underline{K}}{\partial D_1} \underline{\Phi}_m - \lambda_i \underline{\Phi}_m^T \frac{\partial \underline{M}}{\partial D_1} \underline{\Phi}_m \right) \underline{\Gamma} = \underline{\Gamma} \frac{\partial \Delta}{\partial D_1} \quad (8)$$

where $\partial \underline{K}/\partial D_1$ and $\partial \underline{M}/\partial D_1$ are the design sensitivities of the global stiffness and mass matrices, respectively; and $\partial \Delta/\partial D_1$ is a diagonal matrix with diagonal terms equal to the design sensitivities of the eigenvalue λ_i . $\underline{\Phi}_m$ are the vibration modes and $\underline{\Gamma}$ are the eigenvectors of Eq. 8.

FLUTTER DESIGN TECHNOLOGIES

The complexity of modern aircraft structures makes automation of the flutter design cycle essential. An aircraft has to be designed flutter-free for all payloads and altitudes. In ADOP, flutter analysis is performed with the modal approach, i.e. structural characteristics are simulated by a number of selected vibration modes. Both the k (V-g) and p-k flutter analysis methods are available in ADOP. The k-method flutter equation is written as

$$[\underline{K} - \lambda_m (\underline{M} + \underline{A})] \underline{U}_m = \underline{Q} \quad (9)$$

where \underline{K} and \underline{M} are the generalized, or modal, stiffness and mass matrices, respectively. \underline{A} is the generalized aerodynamic influence coefficient matrix. (The discrete aerodynamic influence coefficient matrix is computed using the Doublet-Lattice method [3,4]). λ_m and \underline{U}_m are the complex eigenvalue and eigenvector of the aeroelastic system, respectively, and $\lambda_m = \omega_m^2 / (1 + ig_m)$, where g_m is the damping of the system and ω_m is the circular frequency. The above equation is solved step-by-step along the reduced velocity axis, $1/k$, and the ADOP flutter analysis module directly computes the flutter velocity and frequency.

In the ADOP flutter optimization, a constraint is imposed with an allowable flutter speed. Flutter for all boundary conditions (symmetric and antisymmetric), payloads and Mach numbers can be designed simultaneously. This is much more preferable over the current design process which designs one boundary, payload and Mach number combination at a time.

The velocity constraint is written as

$$G_f = 1.0 - \frac{V}{V_q} \quad (10)$$

where V_q is the design flutter speed with a 15% safety margin.

If the constraint is not satisfied, the structural finite elements have to be resized to increase the flutter speed to meet the design requirement. The flutter design sensitivity can be expressed as

$$\frac{\partial V}{\partial D_I} = \frac{b}{k} \frac{\partial \omega_m}{\partial D_I} - \frac{\omega_m b}{k^2} \frac{\partial k}{\partial D_I} \quad (11)$$

where b is the half reference chord length; $\partial \omega_m / \partial D_I$ and $\partial k / \partial D_I$ are the design sensitivities of frequency and reduced frequency at flutter, respectively. In the k -method, the two design sensitivities are computed by

$$\frac{\partial k}{\partial D_I} = - \frac{Im \left(\frac{1}{\omega_m^2} V_m^T \frac{\partial K}{\partial D_I} U_m - V_m^T \frac{\partial M}{\partial D_I} U_m \right)}{Im \left(V_m^T \bar{A}(k) U_m \right)} \quad (12)$$

and

$$\frac{\partial \omega_m}{\partial D_I} = - \frac{\omega_m^3}{2} \left[\frac{\partial k}{\partial D_I} Re \left(V_m^T \bar{A}(k) U_m \right) + Re \left(V_m^T \frac{\partial M}{\partial D_I} U_m - \frac{1}{\omega_m^2} V_m^T \frac{\partial K}{\partial D_I} U_m \right) \right] \quad (13)$$

where $Re(\cdot)$ and $Im(\cdot)$ are the real and imaginary parts of the enclosed quantity. V_m^T is the left eigenvector of Eq. 9. $\partial K / \partial D_I$ and $\partial M / \partial D_I$ are the design sensitivities of the generalized stiffness and mass matrices, respectively.

OPTIMIZATION STRATEGY

Case control logic is implemented to guide the analysis and design flow and access appropriate discipline modules. ADOP allows for different boundary conditions of the same structure (symmetric and anti-symmetric) along with multiple load cases, payloads and flight conditions (Mach and altitude). Case control is used to establish which analysis disciplines, and their related loads, payloads, boundary and flight conditions are required during an optimization iteration.

The ADOP multidisciplinary design optimization flow chart is shown in Figure 6. The static strength, modal frequency and flutter analyses are performed between major iterations with the updated structure. The loads and aerodynamic data are generated before the optimization iteration. Active and violated constraints from the analyses along with their design sensitivities are then collected for optimization. The method of modified feasible directions [11] is used in ADOP for numerical search. If all constraints are satisfied and the weight variation between iterations is within a tolerance, the optimization procedure stops and the results are reported. Otherwise, the iteration continues until it exceeds the allowable number of iterations.

Including all active and violated constraints in the optimization procedure can be too expensive [11]; therefore, in each design iteration only a subset of these constraints is selected. The constraints are evenly distributed among all design variable groups. Results from all boundary, payload and flight conditions and load cases are examined and inactive (very feasible) conditions are neglected in the next iteration to reduce computation.

NUMERICAL STUDIES

A 3-D finite element model of a large subsonic transport aircraft, as shown in Fig. 7, is used to demonstrate the multidisciplinary optimization capability in ADOP. Both stress and

flutter design requirements are assumed and this study focuses on designing the primary wing structure, i.e. the wing box. The compression panel buckling allowables for the upper wing and tension two-bay crack allowables for the lower wing are used along with the von Mises criterion for materials.

The aircraft wing is modelled by 9636 finite elements including rods, membranes, shear panels, lumped masses and generalized stiffness elements (GENEL). However, only the elements composed of the wing box were designed. The fuselage and tail are modelled with simple beams and their presence is required for the flutter analysis and optimization. The model has a total of 9580 degrees of freedom.

The upper and lower wing panels and stringers contained within the wing box include nearly 1000 finite elements. Design variable linking is necessary to reduce the size of the problem. The wing box is divided into two chordwise design groups for the skins and stringers separately on the lower and upper surfaces since chordwise sizing variation is important for this wing. Additionally, the wing box is divided into five spanwise design groups with the boundaries corresponding to span breaks (Fig. 14). The four corner elements of each group are specified to be the independent design variables; a linear variation of thickness and area are defined between each corner variable. With 10 bilinear design groups on the lower and upper wing defined for both skins and stringers, there are 160 design variables.

Figures 8 and 9 present the flutter speed and weight versus iteration for the ADOP optimization process. Two fully stressed design iterations were performed before the numerical optimization. The optimization with stress criteria and a required flutter speed converged in five iterations with the final flutter speed 4% higher than the required speed. Thus, this case is stress critical but not flutter critical. In order to test ADOP for a flutter critical case the flutter speed requirement was arbitrarily increased and a new optimization performed.

Twelve iterations were used before all design constraints were satisfied. The iteration history clearly indicates that the design in the second case was flutter-critical because the final speed converged toward the required speed. In the flutter speed history (Fig. 8), four optimization iterations were performed before the required speed was exceeded. The remaining iterations (7 - 13), prior to convergence, were used to reduce weight while maintaining the stress constraints. An unexpected result was obtained as shown in the weight-iteration plot (Fig. 9), i.e. the final weight from the second optimization run nearly equals to that from the first one. This means that very little weight penalty was paid for a substantial increase in flutter speed.

To investigate this phenomenon, the skin thickness and stringer area distributions for both optimization runs are examined (Figs. 10 and 11). The skin distribution shows an increasing thickness near the wing root at the trailing edge for the second optimization run compared to that of the first run. The change of thickness in other areas is insignificant. Fig. 11 shows that the stringer areas in the same location are reduced for the second run. This indicates that to increase the flutter speed the torsional stiffness of the wing is increased by thickening the skin near the root at the trailing edge. Meanwhile, in the same area the stringer areas are reduced to offset the additional weight and bending stiffness due to the increased skin thickness. These results are very reasonable since an increase in torsional stiffness will separate the bending and torsional modes and thus benefit flutter. The reduction of stringer area and increase of skin thickness changes the stiffening ratio (0.5 preferred by the current design process) and slightly decreases the stress allow-

ables for the two-bay crack. This change in allowables accounts for the slight weight increase. Thus, the flutter requirement was met using only a slight change in allowables and weight.

Fig. 12 and 13 show the final panel buckling allowables and two-bay crack allowables on the upper and lower wing surfaces, respectively. The panel buckling allowables are reduced in the spanwise direction in accordance with the tapered element sizes. Only a slight variation of two bay crack allowables is observed, because the stiffening ratio (Fig. 14) is nearly constant along the wing span.

The CPU time (on an IBM 3090) used for the first optimization run was 6 hours (or \$700. in batch mode) and the second cost 10 hours (or \$1,100.), which would be much more efficient than the weeks or months required for stress, sizing and flutter iterations in the current design process. In addition, the design generated by ADOP is generally superior to that from the current approach due to the simultaneous consideration of all disciplines.

FUTURE DEVELOPMENTS IN ADOP

Loads -- A major reduction of cycle time will be realized when distributed aeroelastic loads are brought into the automated sizing procedure in ADOP. An interfaced procedure for updating these loads as the structure changes will allow rapid convergence of the aeroelastic loads and structural sizing. Such a procedure is the Advanced Integrated Loads System (AILS) which as being constructed to fit into ADOP (see Fig. 15 and Ref. 13).

Currently, trimmed and balanced maneuver and gust loads are produced using a modal approach. Sensitivities of the maneuver loads to design variables have also been included so that aeroelastic load optimization can be undertaken. Aeroelastic load optimization is very important since large potential weight savings are available if the structure can be induced to elastically dump load off the outer wing at limit load factors.

AILS is currently being integrated into ADOP. Some iterated aeroelastic load - fully stressed design cases have been run but aeroelastic load optimization will be ready this year.

Allowables -- Currently, buckling and two-bay crack allowables are calculated in ADOP. Recently, the sensitivities of these allowables to design variables have been implemented and linked to the optimizer. Numerical studies that optimize the structure and allowables together will be undertaken this year. This is important since allowables optimization has a large potential to save weight just as aeroelastic loads optimization does.

Future plans for this capability include the influence of fatigue and crack growth life on the allowables. Thus, inspection requirements can be used as constraints right up front in the design rather than after the fact as is the usual practice.

All of the allowables calculation and sensitivities will be contained in a sub-system call PASOS (Panel Allowables and Sub-Optimization System). In addition to allowables, this sub-system will do a panel optimization on the geometry of the panel structure. For example, the spacing and shape of stringers will be optimized as described earlier for the current

design procedure and the subsequent allowables passed on to the global optimizer in ADOP.

Acroservoelasticity -- A module for acroservoelastic stability analysis with multiple-input multiple-output (MIMO) feedback control systems is currently being developed in ADOP. The purpose is to be able to suppress flutter with both finite element sizes and control law variables as design variables. In the optimization procedure, the flutter design sensitivities for both structural sizes and control variables will be evaluated and flutter constraints will be satisfied with a minimum weight increase. How to set up a control design criterion, for example, by imposing constraints on gain and phase for optimization is still to be determined.

CONCLUSIONS

Current and future design methods for large subsonic transport wing boxes has been described. Current methods produce high quality, safe and affordable structure, however, future multidisciplinary integrated methods offer the potential to significantly reduce cost and cycle time.

The current Douglas Aircraft Company design philosophy and procedure has been outlined and an example given. A future design system, ADOP (Aeroelastic Design Optimization Program), has also been described and an example of flutter optimization with buckling and two-bay crack allowables was given.

Great potential of using ADOP to reduce weight is also expected since stress, flutter, buckling, two-bay crack, aeroelastic loads and active control systems can be simultaneously optimized.

REFERENCES

1. B. E. Schofield, "Computer-Aided Design of Skin-Stiffened Compression Panels," *AIAA/ASME 8th Structures, Structural Dynamics and Materials Conference*, Palm Springs, California, March, 1967.
2. T. Swift, "The Effects of Fastener Flexibility and Stiffener Geometry on the Stress Intensity in Stiffened Cracked Sheet," *Prospects of Fracture Mechanics*, Leydon, Netherlands: Noordhoff International, 1974.
3. E. Albano and W. P. Rodden, "A Double-Lattice Method for Calculating Lift Distribution on Oscillating Surfaces in Subsonic Flows," *AIAA Journal*, Vol. 7, February, 1969, pp. 279-285.
4. T. P. Kalman and J. P. Giesing, "Subsonic Steady and Oscillatory Aerodynamics for Multiple Interfering Wings and Bodies," *Journal of Aircraft*, Vol. 26, October, 1972, pp. 693-702.
5. T.J., Tzong, G.D., Sikes, M.J., Loikkanen, J.P., Giesing, "Integrated Technologies in Aircraft Design Optimization," *Integrated Technology Methods and Applications in Aerospace Systems Design*, Edited by C.T. Leondes, Academic Press Series of "Control and Dynamic Systems", Vol. 52, 1992.
6. A. J. Dodd, K. E. Kadrinka, M. J. Loikkanen, B. A. Rommel, G. D. Sikes, R. C. Strong and T. J. Tzong, "Aeroelastic Design Optimization Program," *Journal of Aircraft*, Vol. 27, December, 1990, pp. 1028-1036.

7. R. M. Pickett, M. F. Rubinstein and R. B. and Nelson, "Automated Structural Synthesis Using a Reduced Number of Design Coordinates," *AIAA/ASME/SAE 14th Structures, Structural Dynamics and Materials Conference*, Williamsburg, Virginia, U.S.A., March, 1973.
8. C. Lanczos, "An Iteration Method for the Solution of the Eigenvalue Problem of Linear Differential and Integral Operators," *Journal Research of the Numerical Bureau of Standards*, Vol. 45, October, 1950, pp. 255-282.
9. B. N. Parlett and D. S. Scott, "The Lanczos Algorithm with Selective Orthogonalization," *Mathematics of Computation*, Vol. 33, 1979, pp. 217-238.
10. K. J. Bathe and S. Ramaswamy, "An Accelerated Sub-space Iteration Method," *Computer Methods in Applied Mechanics and Engineering*, North-Holland Publishing Company, Vol. 23, 1980, pp. 313-331.
11. G. N. Vanderplaats, *Numerical Optimization Techniques for Engineering Design*, McGraw-Hill Series in Mechanical Engineering, McGraw-Hill, 1984.
12. G. N. Vanderplaats, *Numerical Optimization Techniques for Engineering Design*, McGraw-Hill Series in Mechanical Engineering, McGraw-Hill, 1984.
13. R., D'Vari, and M., Baker, "A Static and Dynamic Aeroelastic Loads and Sensitivity Analysis for Structural Loads Optimization and Its Application to Transport Aircraft," AIAA-93-1643, *AIAA/ASME/SAE 34th Structures, Structural Dynamics and Materials Conference*, La Jolla, California, U.S.A., April, 1993.

INTEGRATED MULTIDISCIPLINARY STRUCTURAL DESIGN

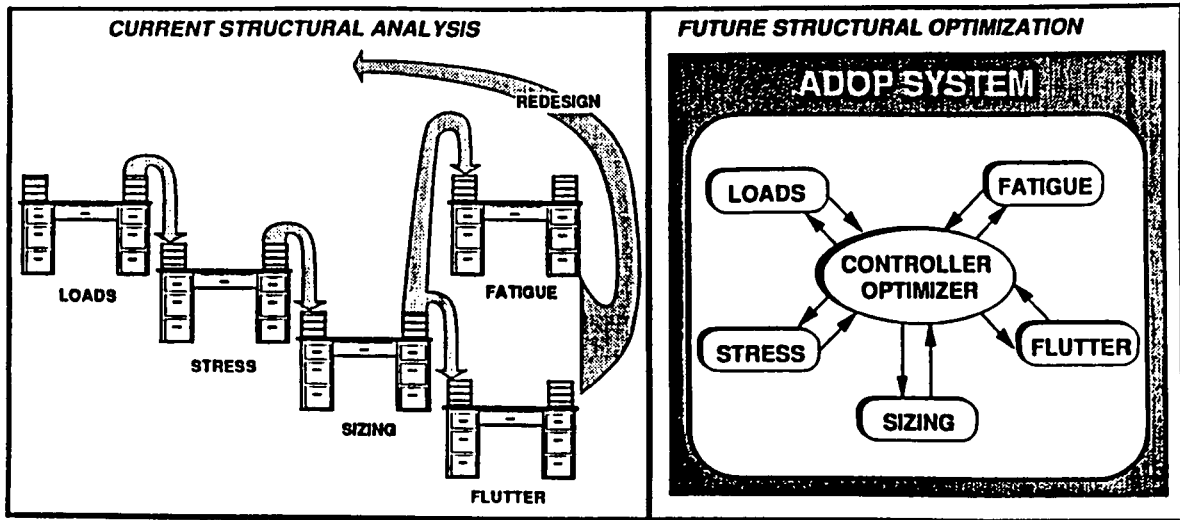

(a)

(b)

Fig. 1. Schematic of Current(a) and Future (b) Design Processes

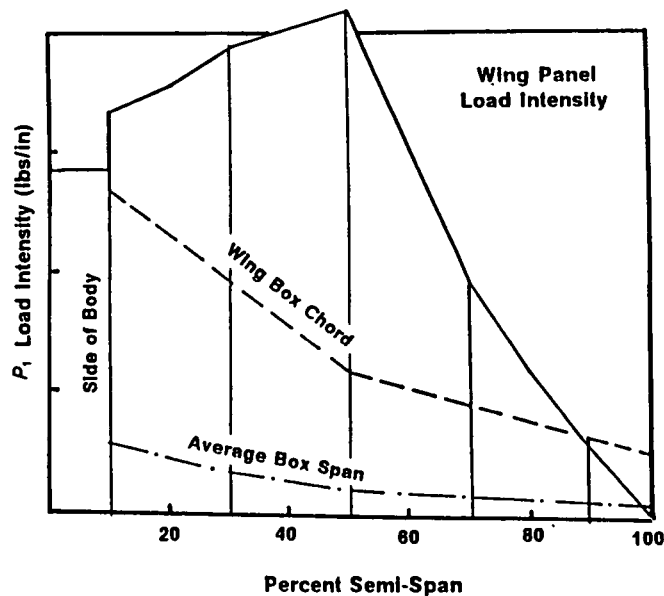

Fig. 2. Load Intensity (Ultimate, Inplane, lbs/in) Across the Wing Span

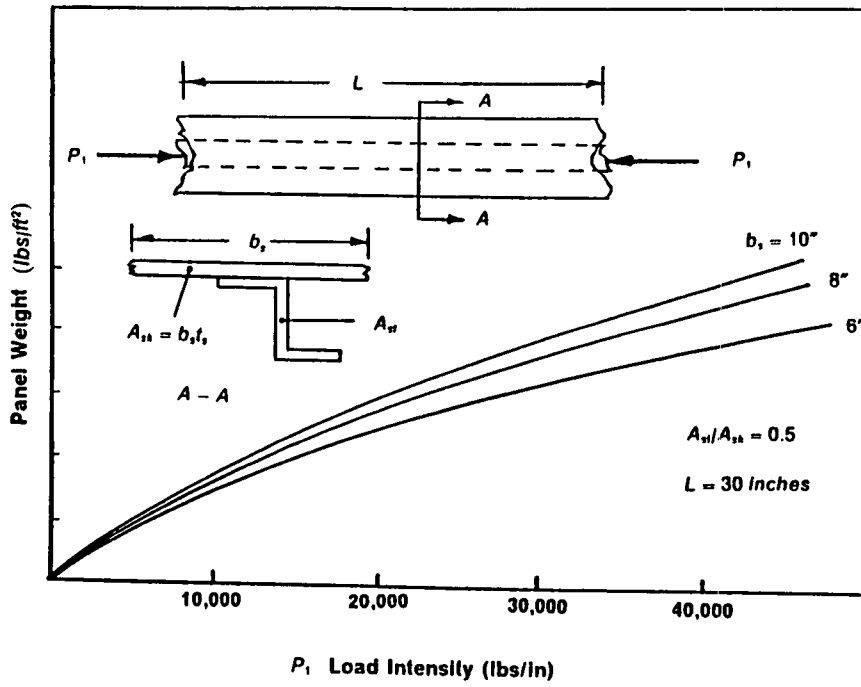

Fig. 3. Parametric Panel Weight vs. Inplane Load for Various Stringer Spacings at a Given Rib Spacing (30 in) and Stiffening Ratio (0.5)

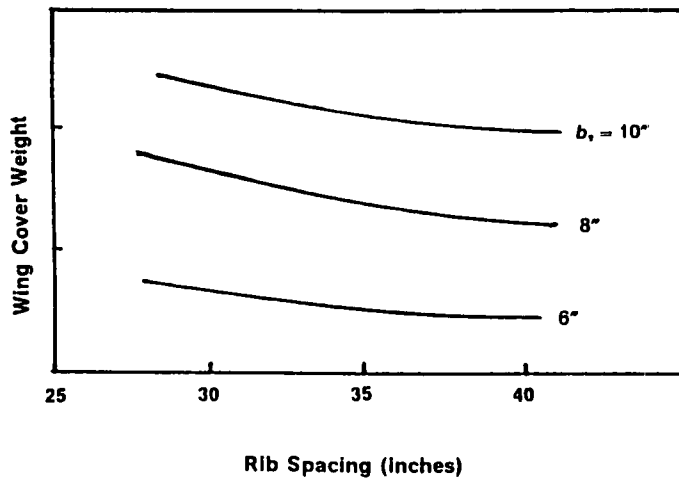

Fig. 4. Total Wing Box Weight vs. Rib Spacing for Various Stringer Spacings

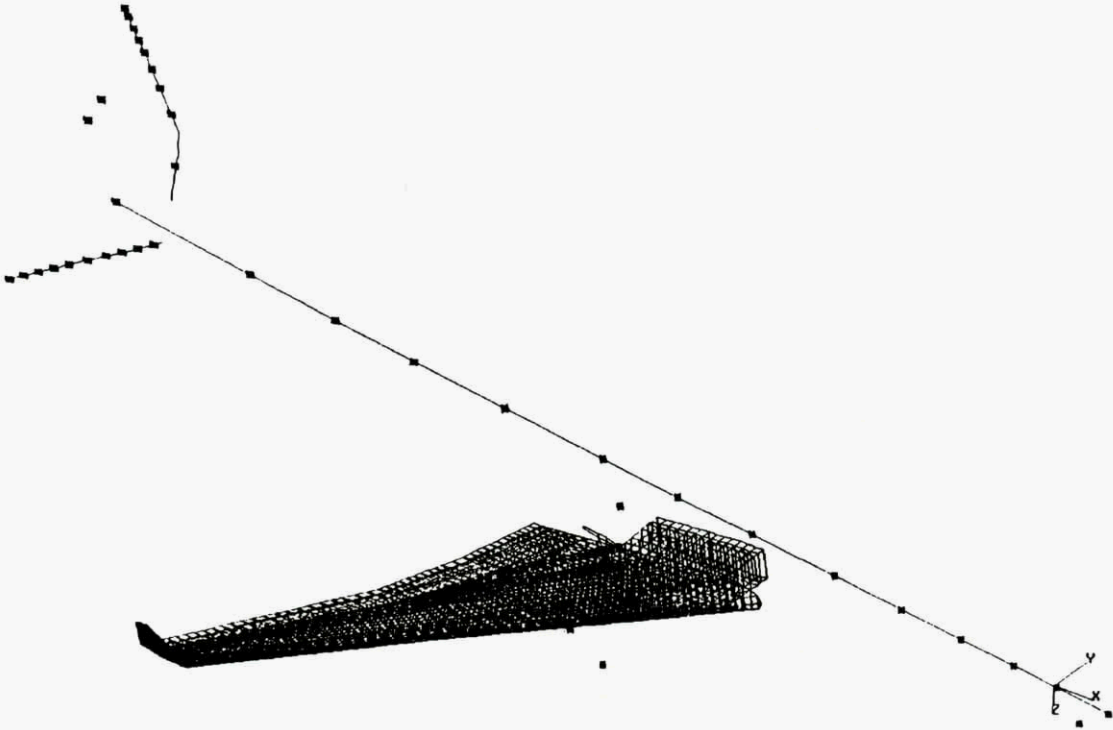

Fig. 7. 3-D Finite Element Model for Stress and Flutter Design

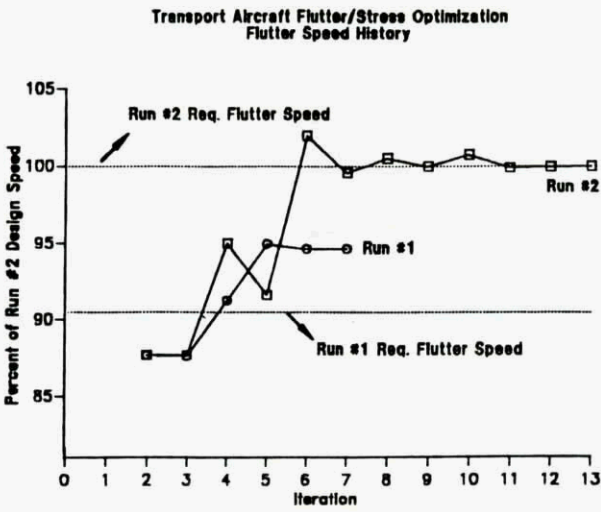

Fig. 8. Flutter Speed Versus Iteration

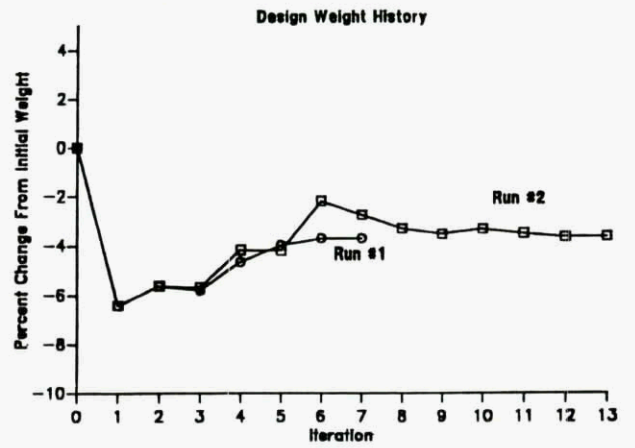

Fig. 9. Weight Versus Iteration

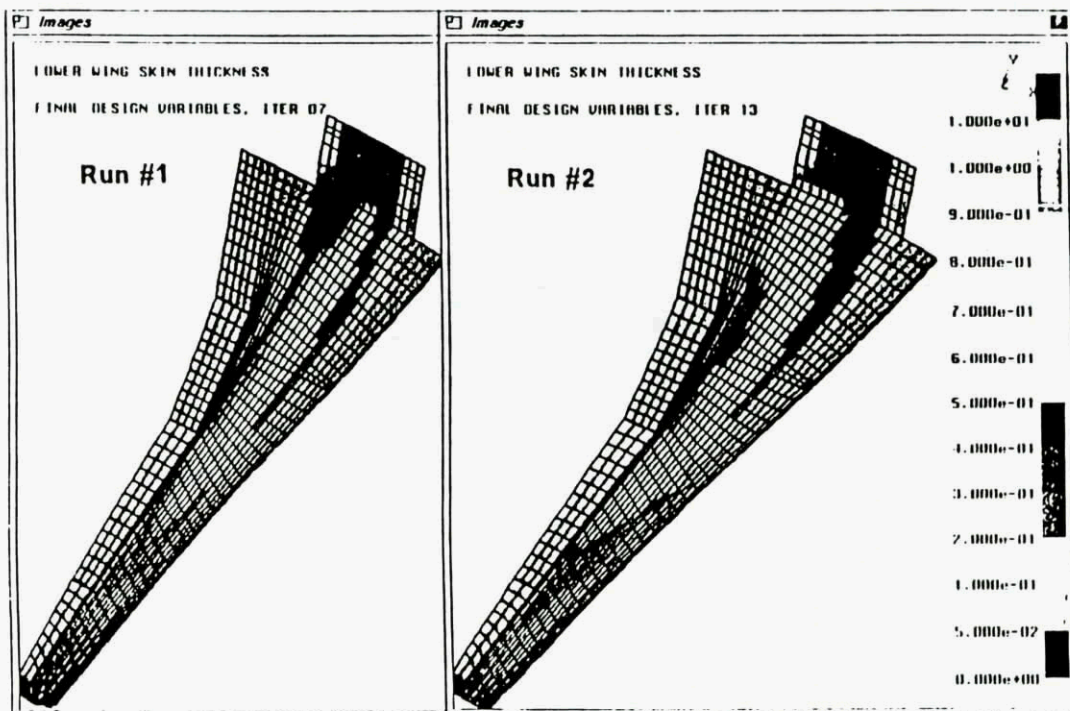

Fig. 10. Comparison of Skin Thickness Distributions

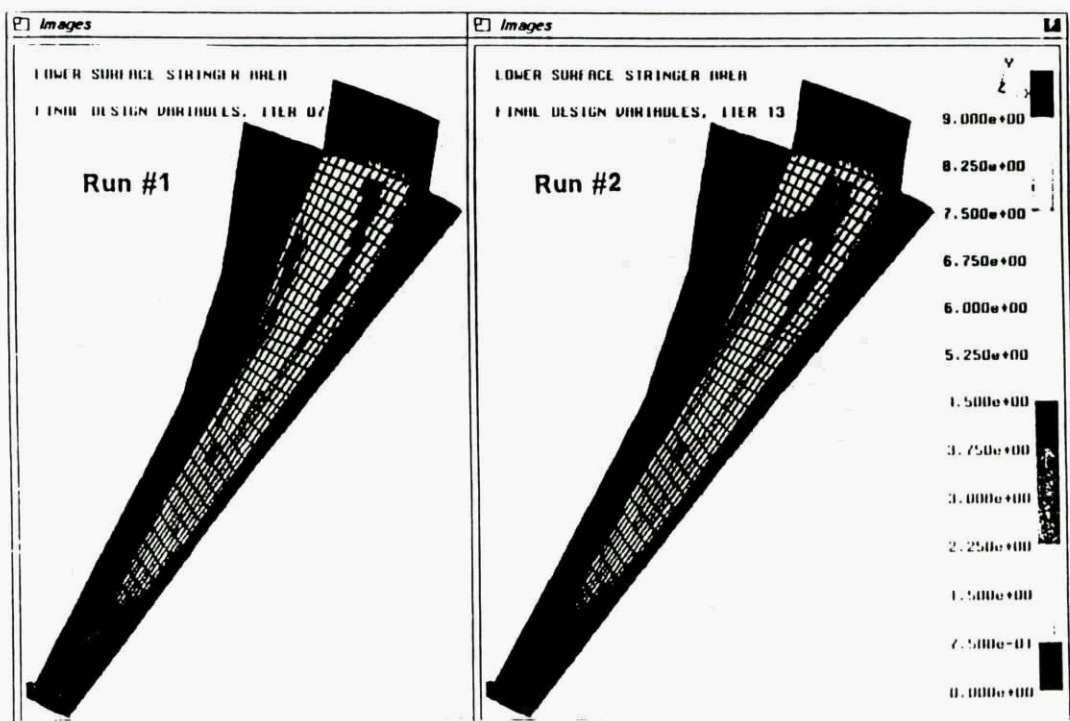

Fig. 11. Comparison of Stringer Area Distributions

MD-12 Lower Surface 2-Bay Crack Stress Allowables
 2 FSD's + 10 MDO's, Flutter > 619 Knots
 Toughness Factors of 110 ksi, 140 ksi

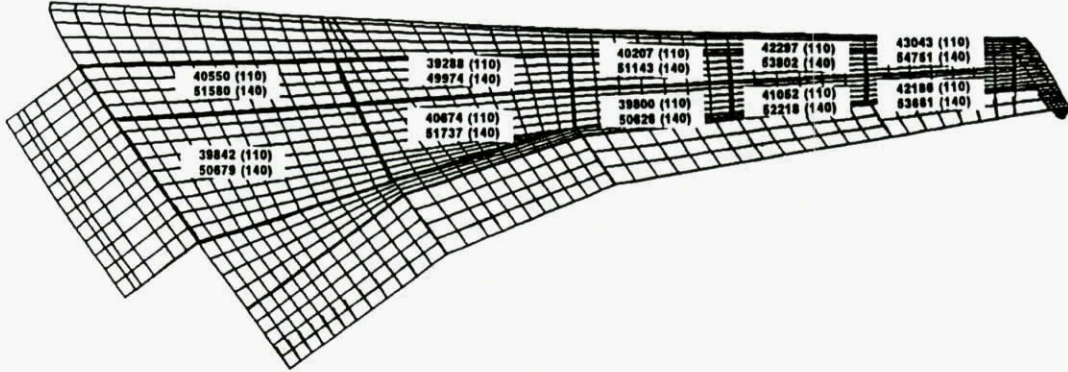

Fig. 12. Lower Surface 2-Bay Crack Stress Allowables

MD-12 Upper Surface Buckling Stress Allowables
 2 FSD's + 10 MDO's, Flutter > 619 Knots

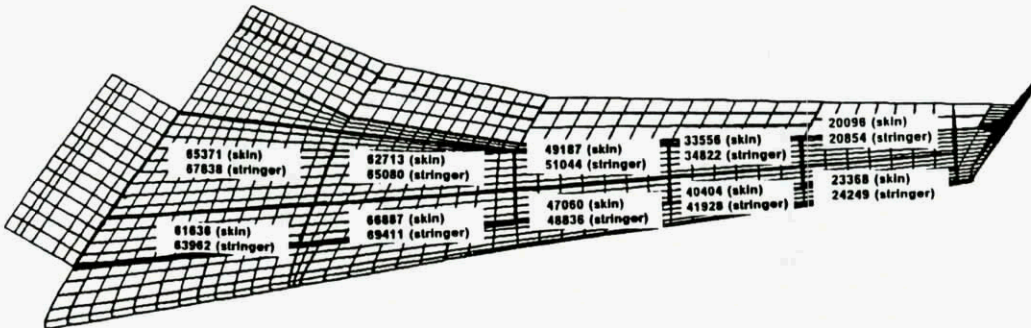

Fig. 13. Upper Surface Panel Buckling Stress Allowables

MD12-T4V Lower Wing Stiffener Ratios
 2 FSD's + 10 MDO's, Flutter > 619 KEAS

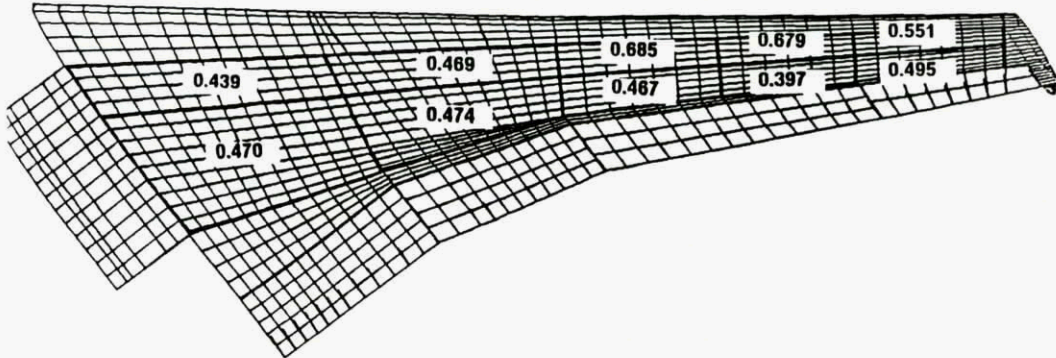

Fig. 14. Lower Wing Stiffening Ratios

AEROELASTIC DESIGN OPTIMIZATION PROGRAM

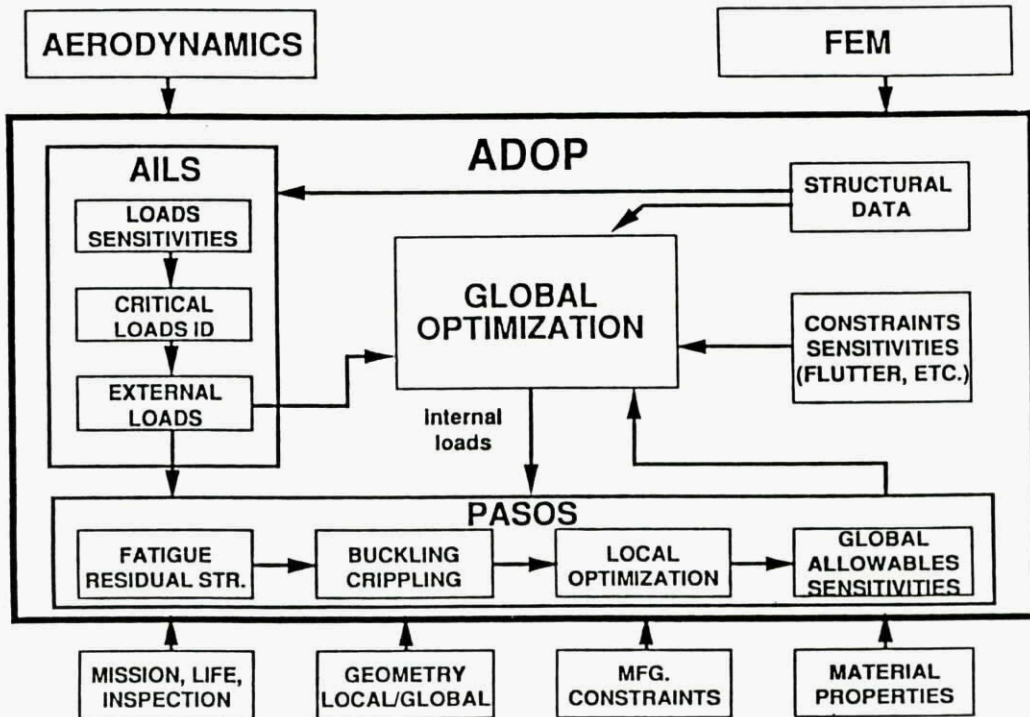

Fig. 15. Future ADOP Capability for Loads (AILS) and Panel Sub-optimization (PASOS)

THE INTEGRATION OF DESIGN AND MANUFACTURING PROCESSES AT ALENIA DVD

by

L. Chesta, M. Flaccavento, G. Pollano and F. Staropoli

Alenia, Settore Aeronautica
Divisione Velivoli Difesa
Corso Marche 41 — C.P. 432
10146 Torino
Italy

1. INTRODUCTION

In Aeronautics the pioneers era, or, if you prefer, the age of high creativity like the one in the fifties with the introduction of the jet engines, or the one of the aero/structural revolution in the thirties which started the age of the monoplanes with metallic shell structure and ended the biplanes period, is passed.

Nowaday, we are in a stall situation where the final increment in the basic performances (max speed, manouver capability) is usually excessively expensive.

It is now the time when it is necessary to look to marginal areas to gain improvements in the performances, to use new materials like carbon fibers to tailor the structure to the needs and to simplify, with the help of electronics and servomechanism, complicate mechanical systems to obtain aircraft architectures otherwise impossible to be flown.

But this is not enough and is absolutely necessary to improve also the cost/effectivity ratio both increasing the reliability, availability and supportability of the weapon system to reduce the usage cost and to reduce the production cost of the aircrafts.

This is not any more achievable using the single man capabilities on a single discipline but it is required a new type of working organisation which uses on one side sophisticated means of calculation integrated in order to optimize the overall design and on the other compresses the time of the process trying to exploit the synergism of the interdisciplinary couplings, overlapping as much as possible the design and manufacturing phases.

Alenia Defence Aircraft Division being involved in several programmes both individual and in international cooperation has followed this evolution and is actively pursuing the adequacy of its operative structure to the new requirements by adopting advanced technology processes.

2. ALN COMPUTATION CAPABILITY

The first step has been to operate on the computing side to rationalise the architecture of the system.

The logic followed has been to have a common Data Base for lofts, loads, aerodynamics data and other from which, to allow flexibility, each department can take and introduce data with their own special software (of course following appropriate procedures to assure that the date are not corrupted) and using defined exchanging data protocols.

The functional connections between the different computers and the main software tools used by the different departments and the main data bank are shown in fig. 2.1.

Each office has work-stations for the interactive (3D) graphics and work-stations as servers for Xterminal, mainly used for editing work or plotting graphics.

A server is dedicated to the scalar analyses and share data bases.

The Cray Y-MP is for intensive computing (CFD, CST,...).

A detail on how structures and aerodynamics interfaces is shown in fig. 2.2.

Both start, and finish, at geometrical model (i.e. CATIA model).

Then, for structural analysis, a structural mesh is defined on the geometrical model, by means of specialised code like SDRG/IDEAS.

The highly interactive work like the visualisation of the analysis results where standard and ad hoc code may be used, is performed on work-stations.

The FEM analysis run on the Cray where MSC/NASTRAN, MSC/DYNA or dedicated code are available.

The Aerodynamic analysis is nearly based on in-house development computer codes. For the codes based on Euler equation a dedicated step of grid generation is necessary.

All the interactive graphics is carried out on the workstations while the aerodynamic analysis take advantage of the vectorisation speed-up of the Cray.

The hardware resources available to support the CAE/CAD/CAM system are shown in fig. 2.3 and consist mainly of a Cray Y-MP and an IBM 570 connected between them and to the IBM RISC 6000-980 user as data bank via an high speed fibre optic channel.

All the Working Station or Xterminals in the officies are connected to this channel together with the Numerical Control stations.

3. COMPOSITE WING DESIGN AND MANUFACTURE

This is one of the most complex example of integration achieved in ALN between design and manufacturing.

This wing has many interesting design innovations, but the most interesting feature is that the spares are cured and bonded in one shot with the precured lower skin as shown in fig. 3.1 in order to reduce to the minimum the total weight of the wing and the assembly operations.

After a first optimisation cicle at A/C level, a more detailed aerodynamic/flight mechanics/load/structure iteration was made in order to optimize the manouvre loads for the required roll rate capability and therefore minimize the trailing edge hinge moment and the associated actuators size and define the skin minimum thickness distribution according to the preselected fiber orientation.

The typical grid used to simulate the box skin for the optimisation calculation is shown in fig. 3.2 while a typical isothickness plot obtained for the upper skin is shown in fig. 3.3.

A further optimisation cicle, this time purely structural was then performed in order to take care of the local conditions like bucklings and local deformation (fig. 3.9).

The optimal skin thickness distribution, obtained in this way, after an exercise of design for manufacture in strict cooperation between the design office and manufacturing, is than transferred in a more realistic, from a manufacturing point of view, layer distribution (see fig. 3.4) that may be different in details for a component designed for manual or automatic lamination (fig. 3.5).

In order to allow an easy series production an automatic tape laying machine (10 axes c.n.c. controlled) capable to make parts up to 9 meters long and 5 meters wide has been implemented in ALN-DVD plants (fig. 3.6), fully integrated in the CAD/CAM system.

Both during the design and the numerical control programming phase, a software tool called ACRAPATH is usefully employed (fig. 3.7-3.8) by manufacturing as a production tool, in order to create the numerical control instructions for the tape laying machine motion and by design office as a simulation tool to control in advance the design tolerance.

The available loft data base has also been used to derive the design of the surface of the moulds on which the wing skin layers have been laid down and to check them.

The strict interaction achieved during the definiton phase between design and manufacturing has also allowed to approach the problem of the assembly line in an integrated way. The result is an intuitive mounting sequence with parts designed with forms and tolerances favourable for an easy assembly and a minimum number of tools and jigs to complete the assembly sequence (fig. 3.12).

4. DESIGN FOR MANUFACTURING

The wing is a good example of the effort made in order to obtain a design not only compatible but also optimized for the facilities available and for the automatic manufacturing of the parts but is not the only one.

All designs and most industrialisation activities are performed using CAE/CAD/CAM tools in an integrated managed manner, supported by appropriate procedures (see fig. 4.1).

The data generated in the design department are directly available to engineering and production in the required form (see fig. 4.2). The results are shortened processing times for the product, enhanced quality and higher efficiency due to the better form of data exchange.

As an example it is possible to follow one machined part (an engine aft mount support) from the initial layout to the NASTRAN schematisation (fig. 4.3) to the coloured stress distributions (fig. 4.4), the stressed layout, the tooling drawings (fig. 4.5), the preparation of tapes for the N/C machine milling tool, the check for

quality control inspection machine and finally the parts list for product support publications (fig. 4.6).

5. SYSTEM INSTALLATION OPTIMISATION

Another area in which there have been some development in ALN is that of the use of 3D models to build up an electronic mock-up for complex installations.

The construction of mock-ups, although they are made of easily available and not expensive materials which are not subject to stress or fatigue, requires costs and realisation times, often heavily impacting on the total cost of the project.

The introduction of CAD tools and the following evolution of design methodologies to the 3D modelling, has made possible an analytical approach to the test of design.

The checks performed on the physical mock-ups are now performed using specific analysis software on digital models, which are available since the first phases of design.

The example shown is the design of a bay in the rear fuselage, very difficult because of its shape and the complexity of the equipment installation and the cables and pipes routing.

The design route followed in ALN is shown in the flow chart (fig. 5.0).

The other pictures show the structure the systems designed in 3D and the total installation of all the systems.

Each figure is related to the relevant level of the above flow chart.

The benefits gained can be summarized as follows:

- lower costs due to the elimination of physical models;
- greater accuracy and time reduction, because the digital mock-up is built using the 3D models created by designers and soon available in the design cycle;
- possibility to perform a digital preassembly of all the components in a bay to decide the best installation sequence and design the assembly jigs in advance with perfect reference points reducing the risk of errors during final assembly.

A fall-out of this way of operating are the drawings of the cable looms and pipes, including the bills of materials obtained automatically and also the possibility to transfer directly the information in the data base to the special machine in the shop to automatically bend, cut and finish the pipes.

A tool at the moment in the experimental stage at ALN that is expected to provide big advantages is ALEX (fig. 6.1).

ALEX is an expert system developed in ALN that on the basis of the 3D design of bay structure, of established design criteria like minimum distance between lines, aggregations and separation rules provides automatically the optimal cables routing, loom aggregation and connector selection.

CAE / CAD / CAM ARCHITECTURE

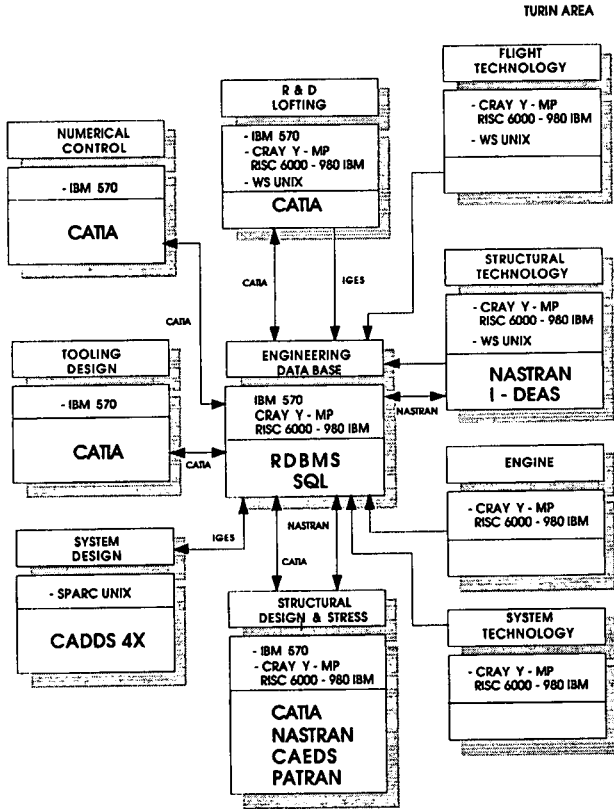

**INTERACTIONS BETWEEN GEOMETRICAL MODEL
 AND AERODYNAMIC / STRUCTURAL DESIGN**

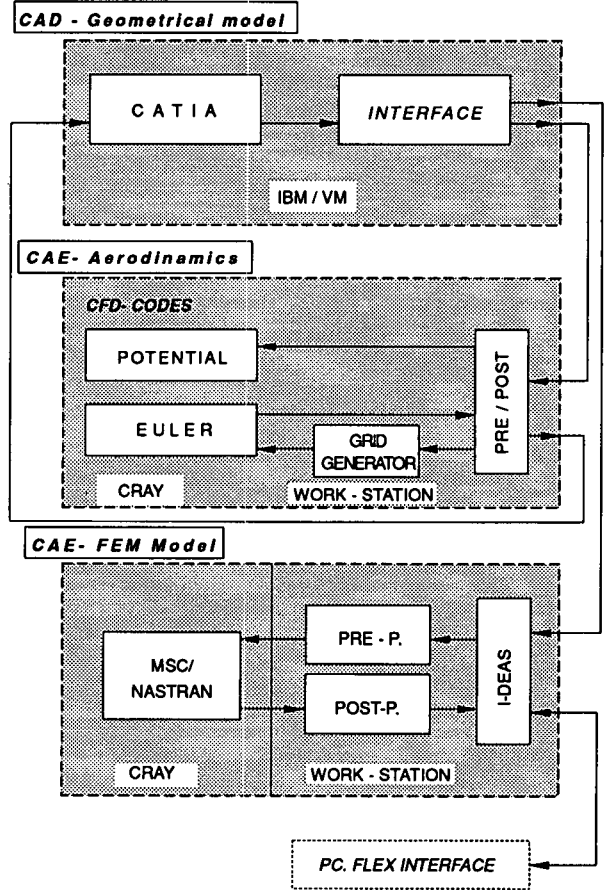

COMPUTER SYSTEM ARCHITECTURE

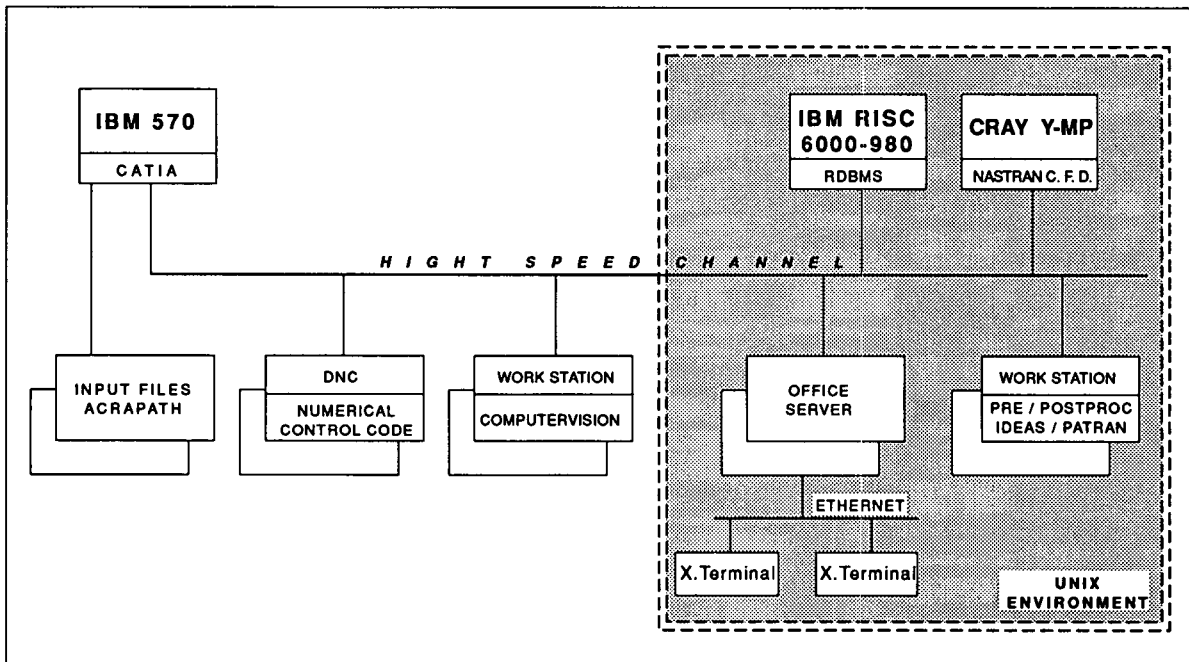

WING BOX ARCHITECTURE & DETAIL OF BONDED JOINT

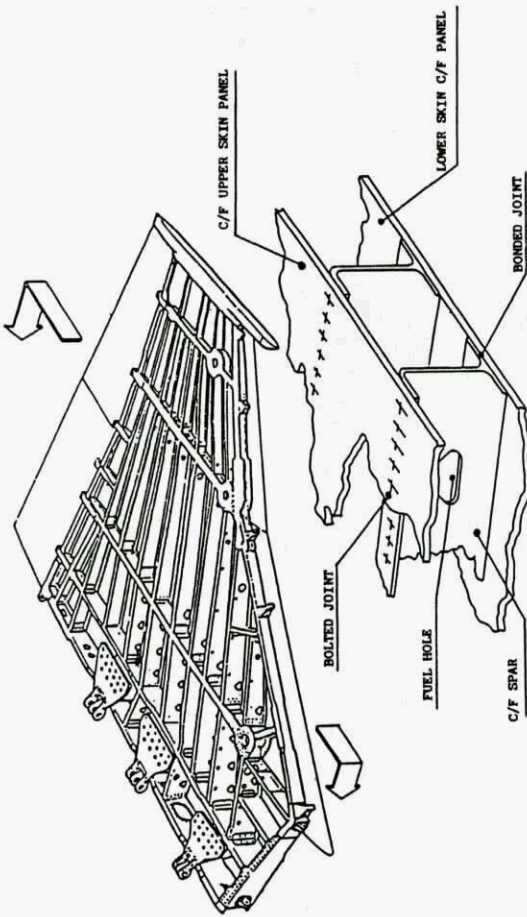

UPPER WING SKIN - TYPICAL STRUCTURAL OPTIMIZATION GRID

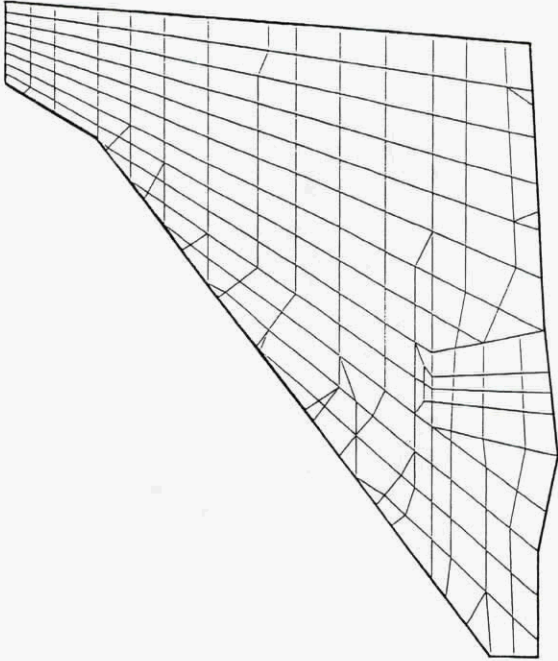

COMPOSITE AUTOMATIC - LAYING

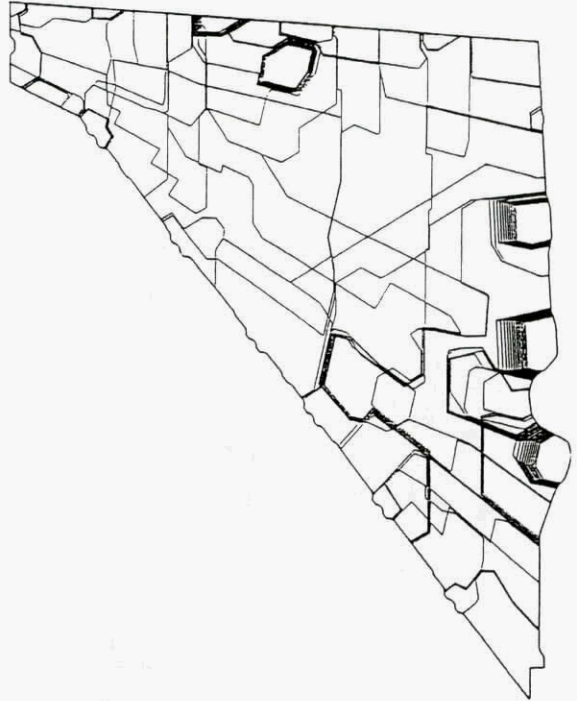

TOP SKIN TOTAL THICKNESS

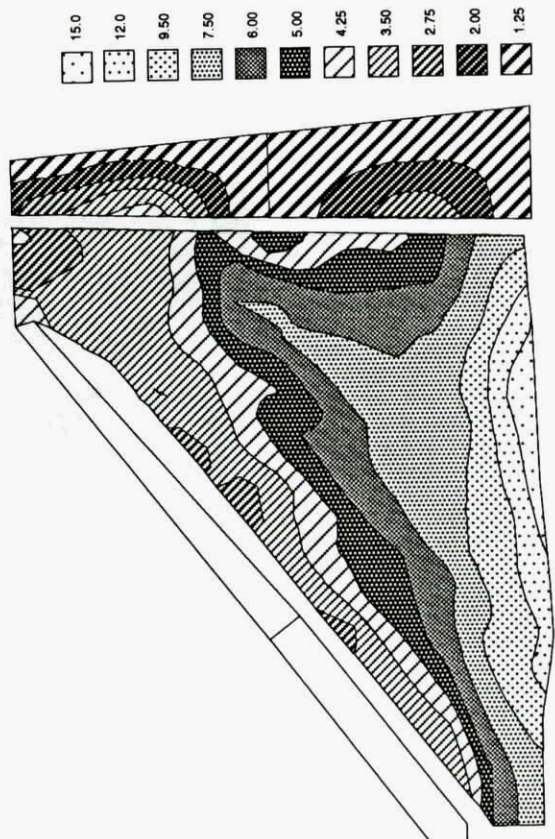

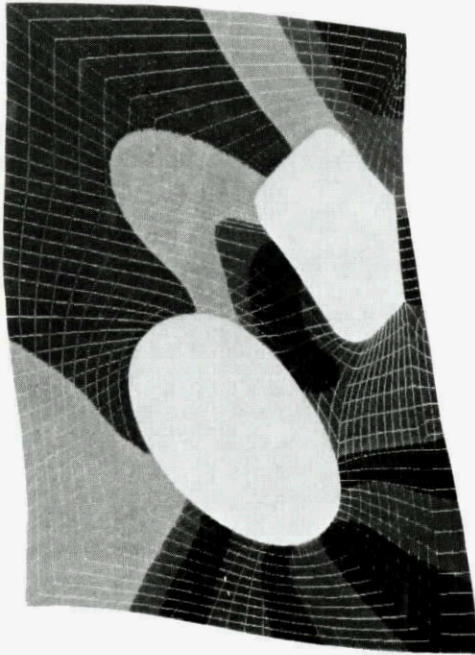
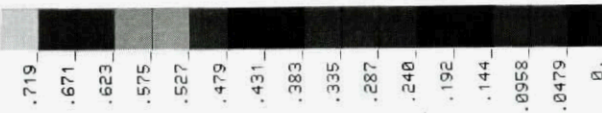

EXAMPLES OF BUCKLING ANALYSIS

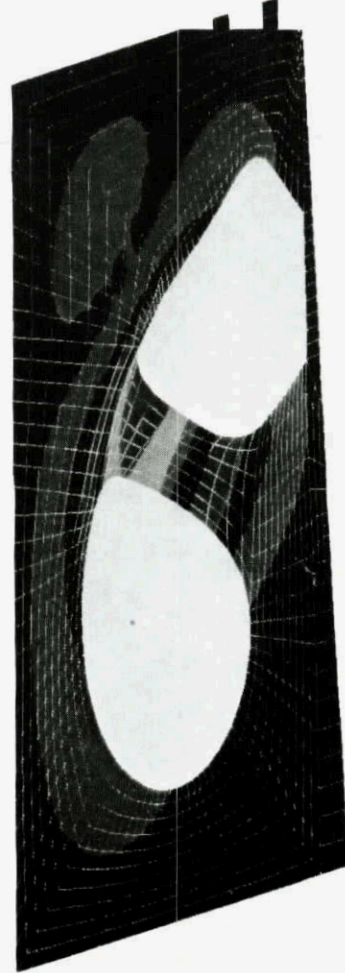
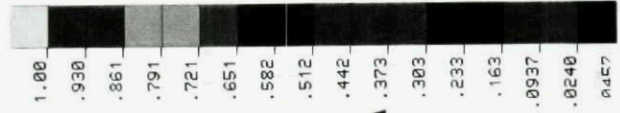

BUCKLING: DESIGN LOAD CONDITION

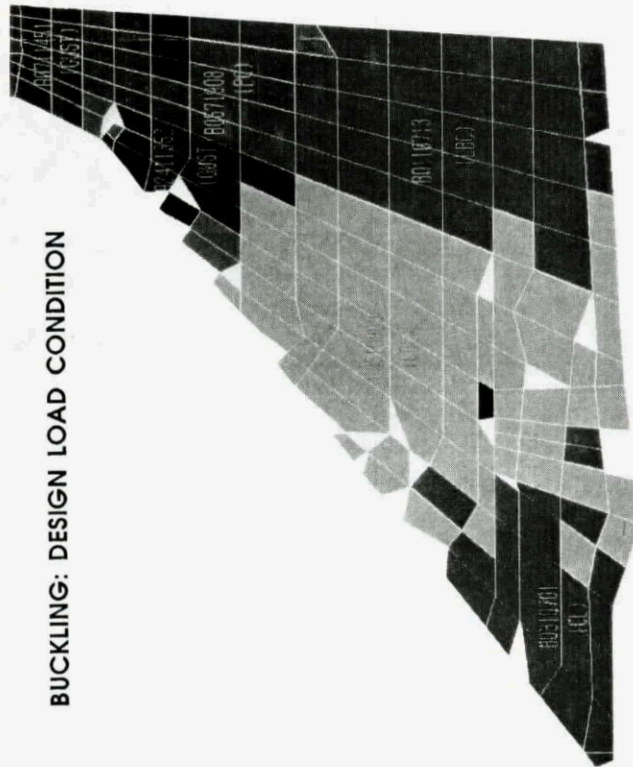

COMPOSITE AUTOMATIC - LAYING

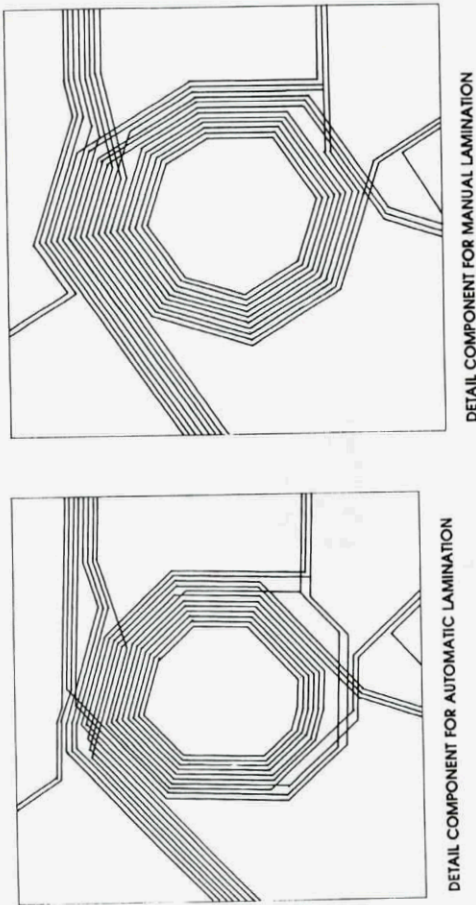

CAD / CAM
 TAPE LAY-UP MACHINE ACTIVITY FLOW DIAGRAM

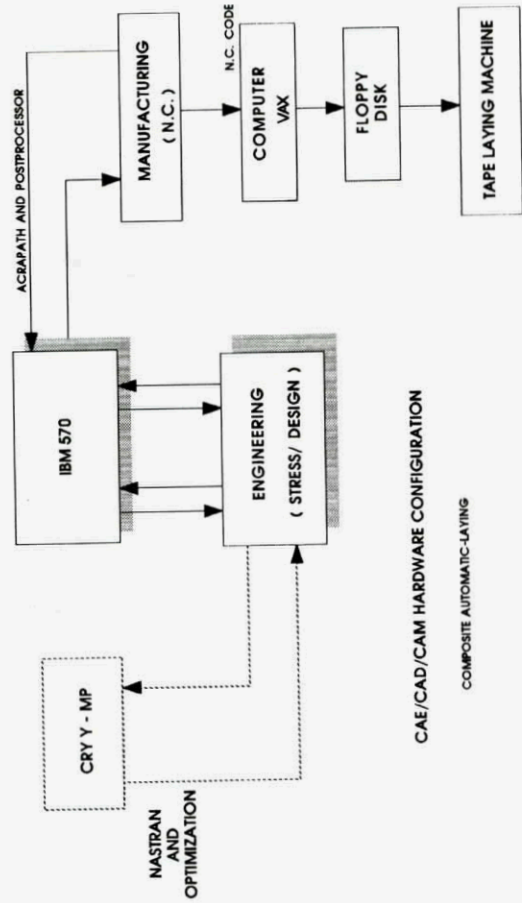
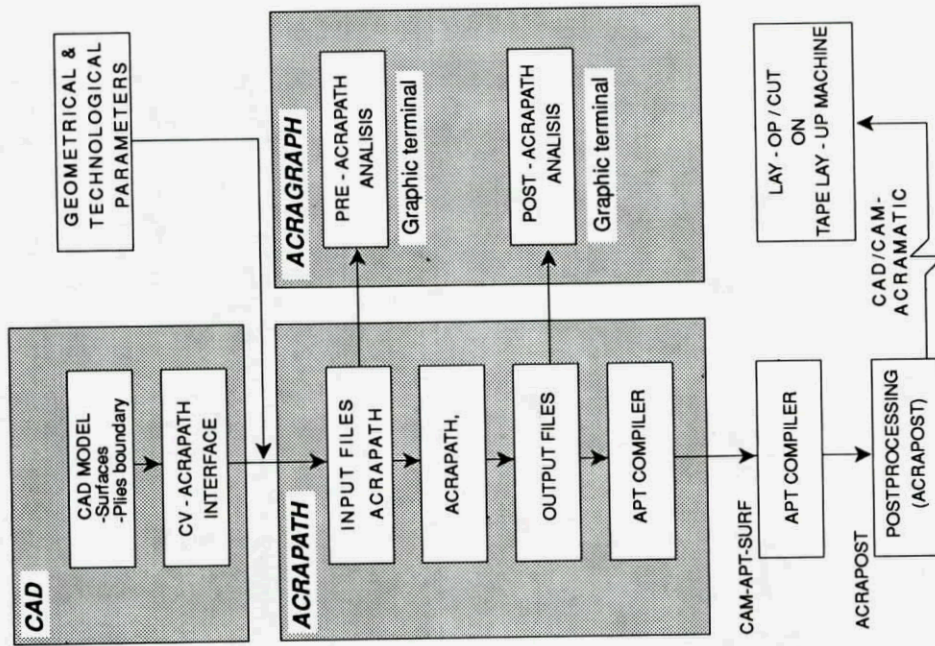

CAE/CAD/CAM HARDWARE CONFIGURATION

COMPOSITE AUTOMATIC-LAYING

AUTOMATIC TAPE LAYING MACHINE

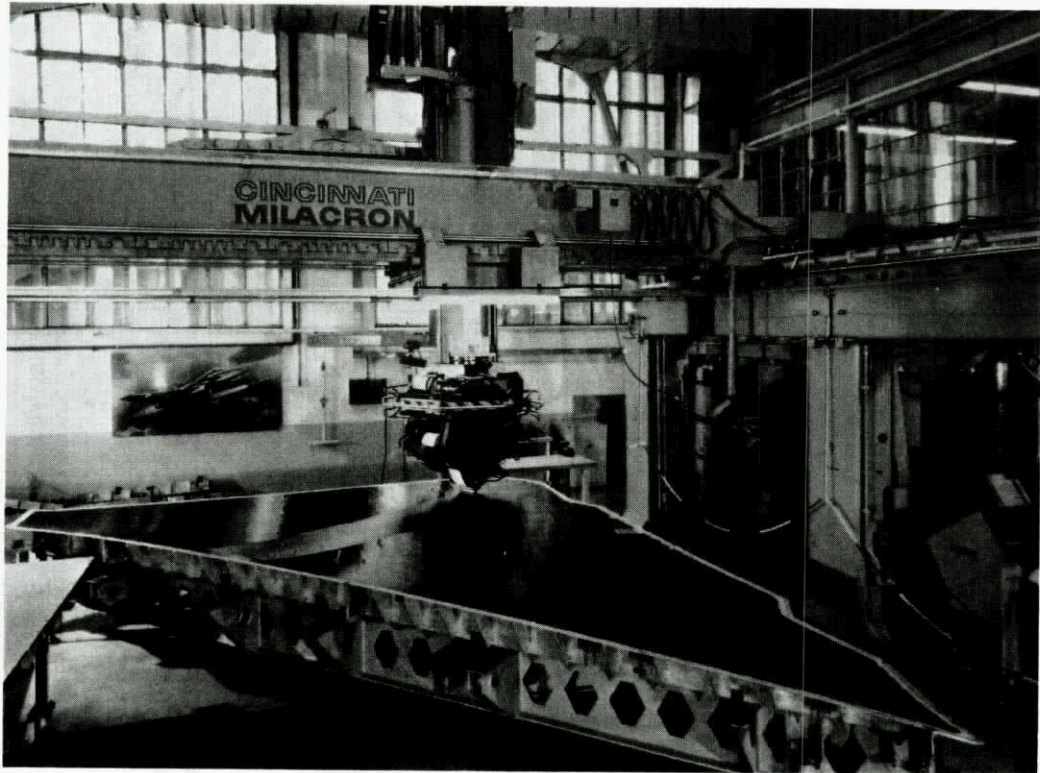

WING ASSEMBLY SEQUENCE

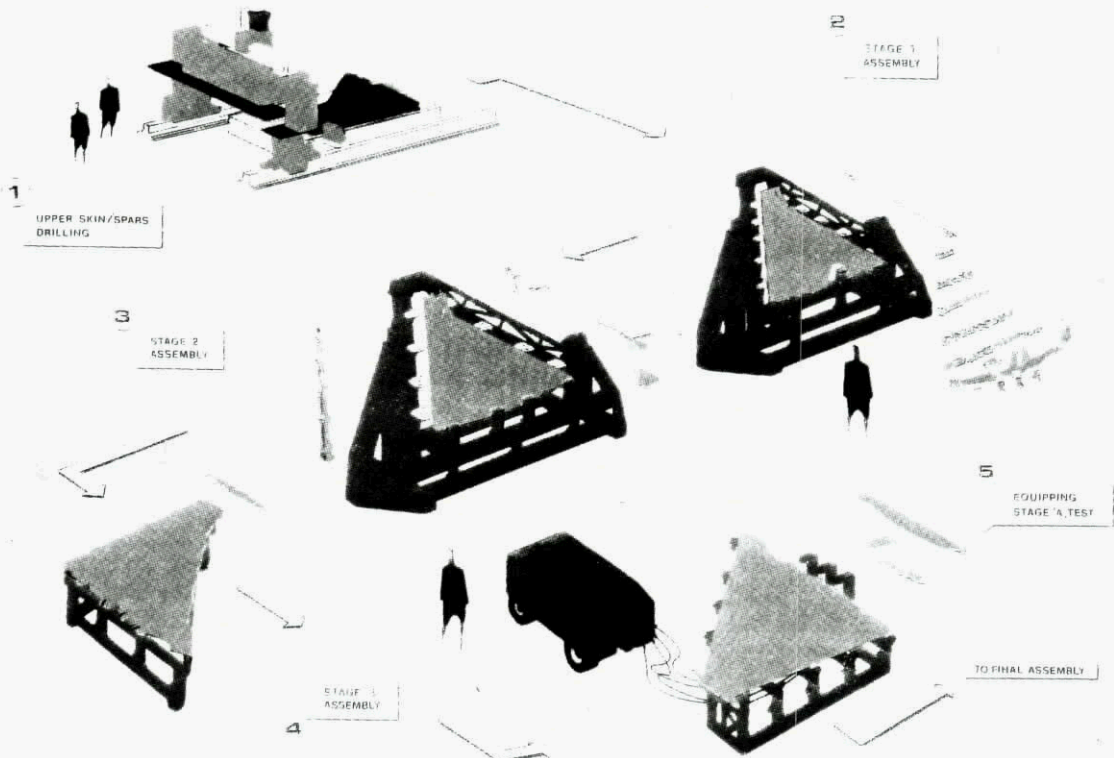

AFT ENGINE MOUNT

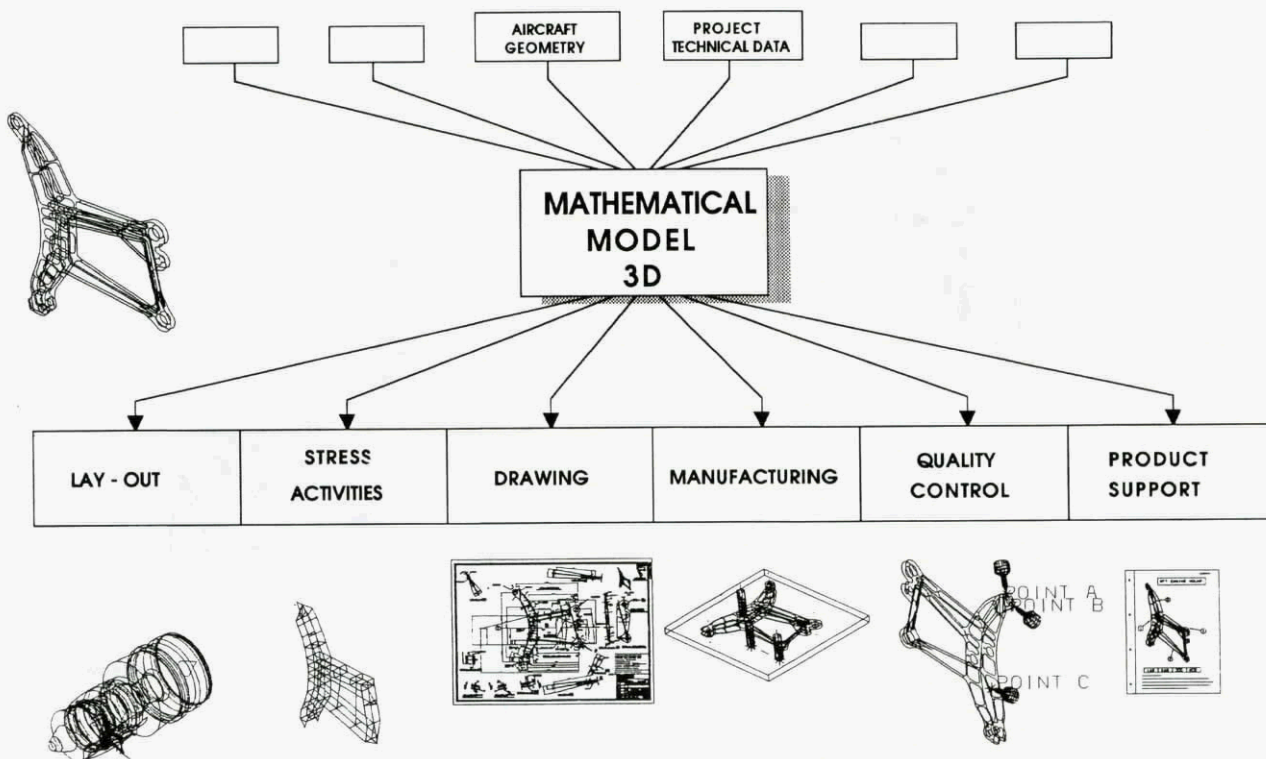

MANUFACTURING ACTIVITY FLOW CHART

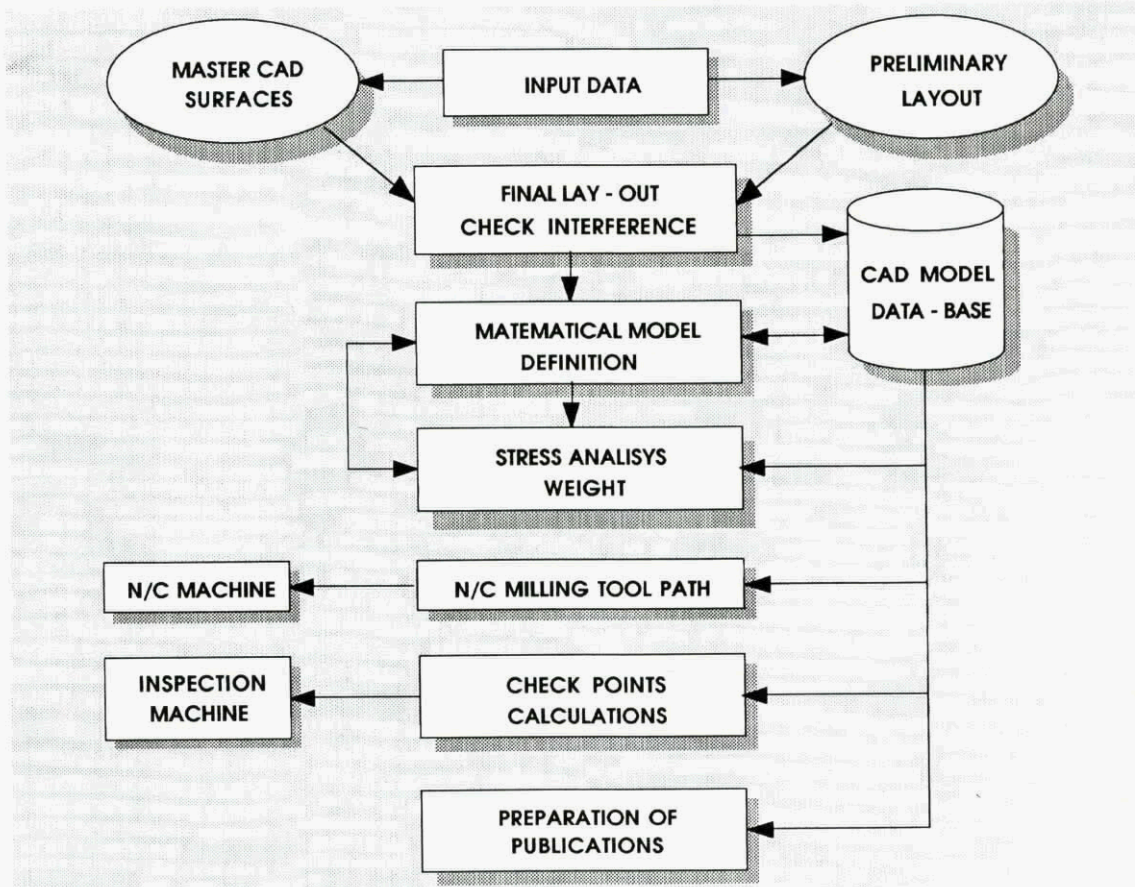

FIG 5.1 : CLASS 1 STRUCTURE

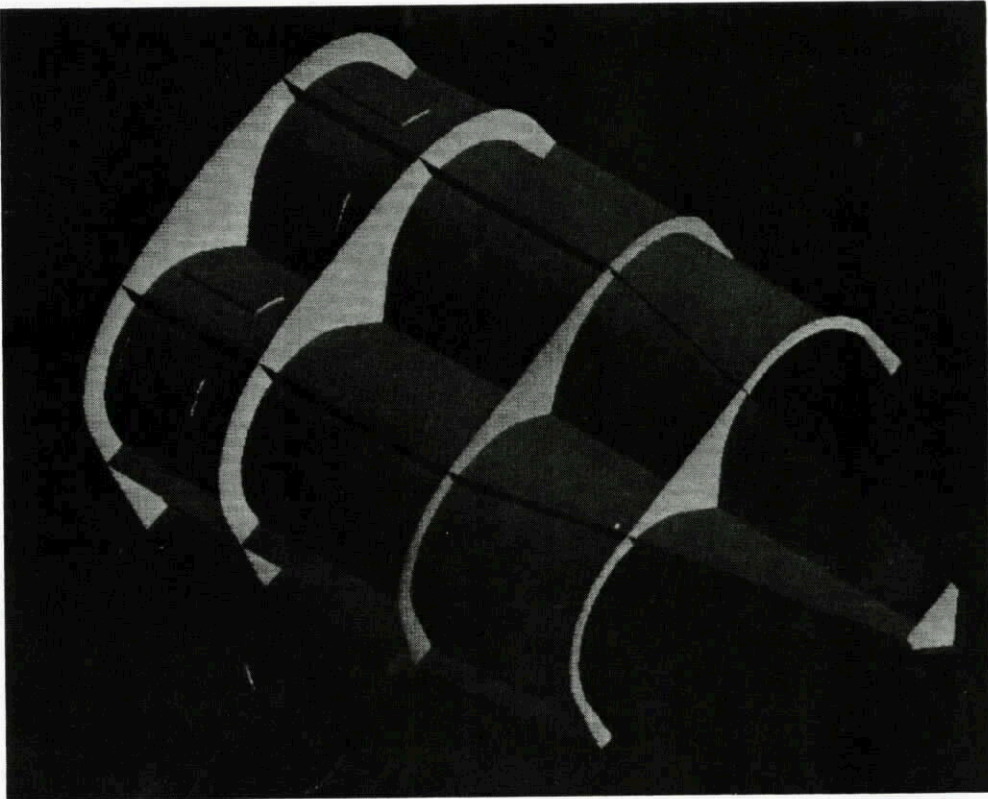

FIG 5.2 : FUEL SYSTEM - CLASS 1

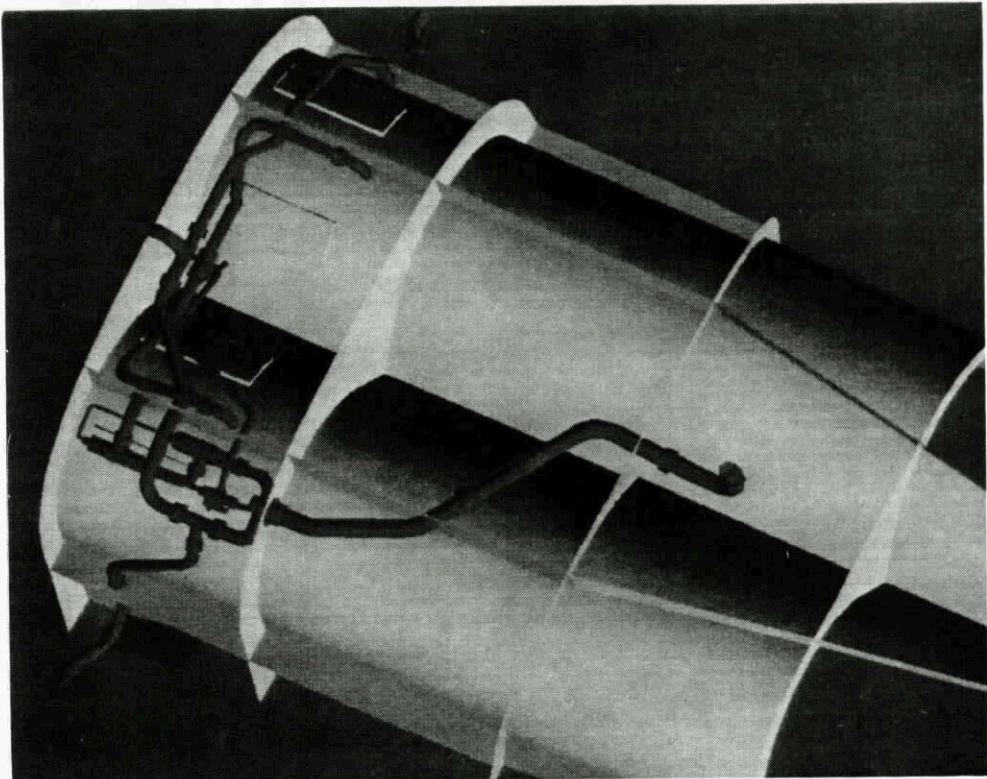

FIG 5.3 : HYDRAULIC SYSTEM - CLASS 1

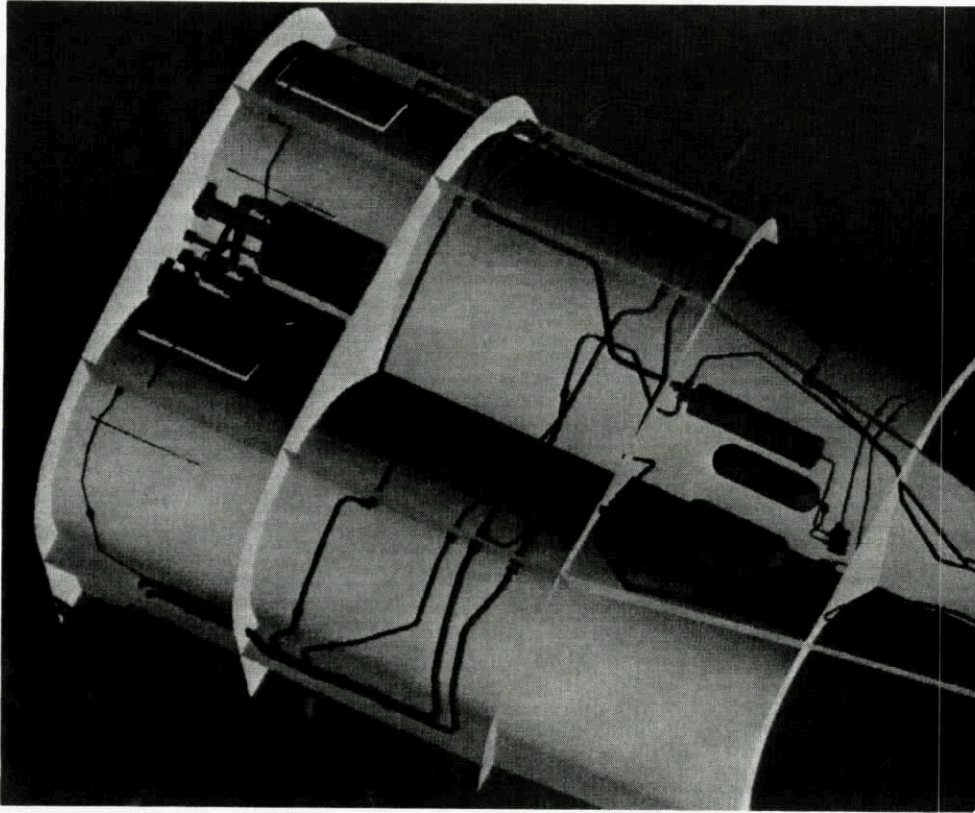

FIG 5.4 : DMU INTEGRATION - CLASS 1

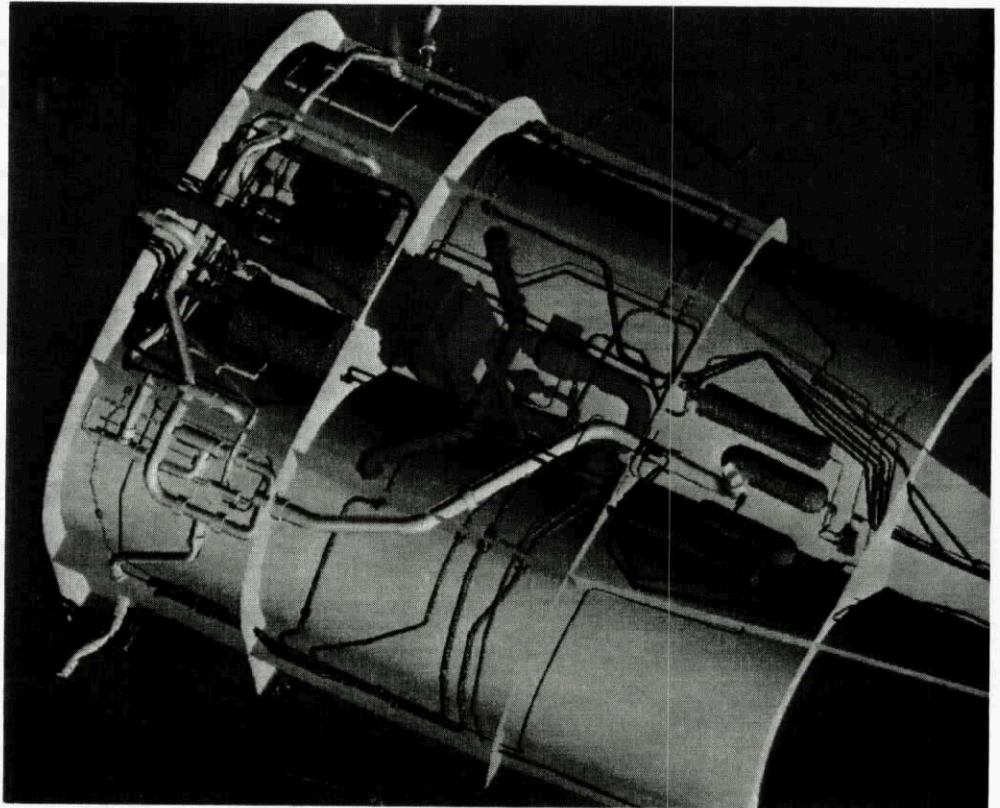

FIG 5.5 : CLASS 3 STRUCTURE

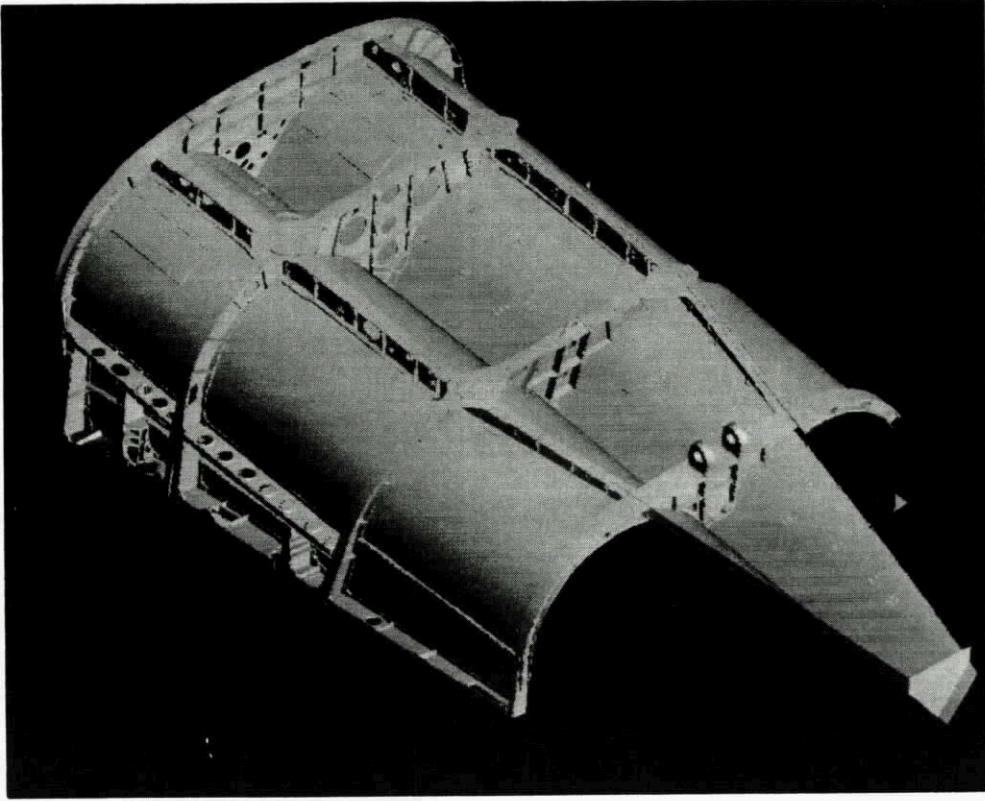

FIG 5.6 : ELECTRIC SYSTEM - CLASS 3

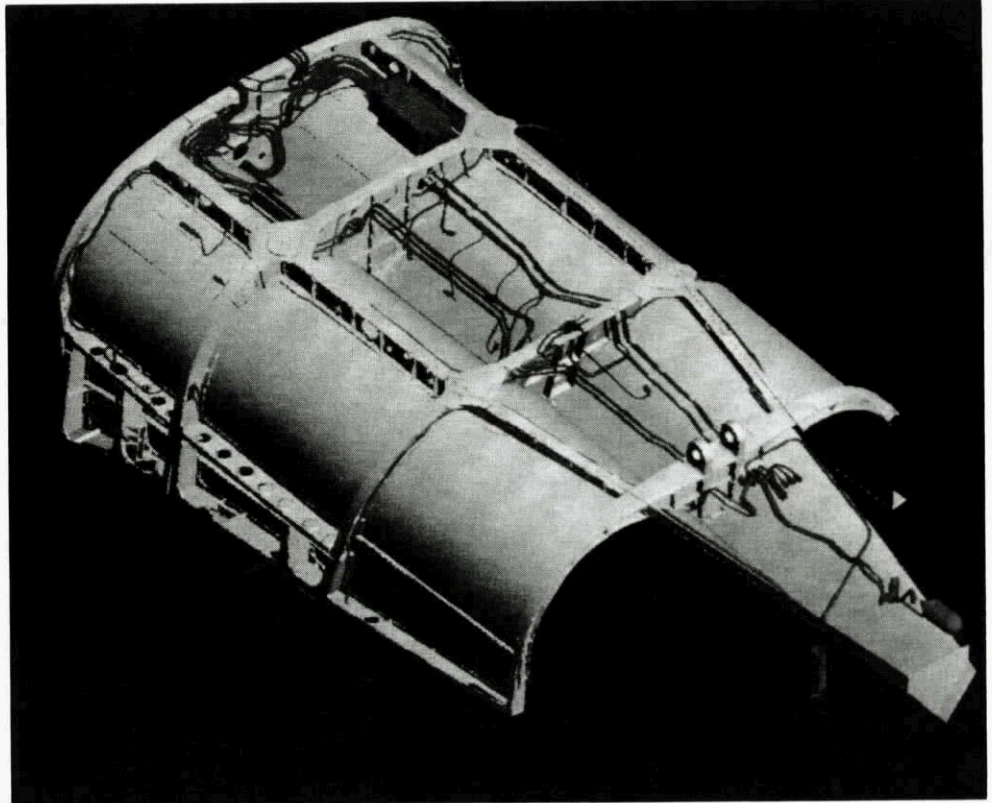

FIG 5.7 : ENVIRONMENT CONTROL SYSTEM - CLASS 3

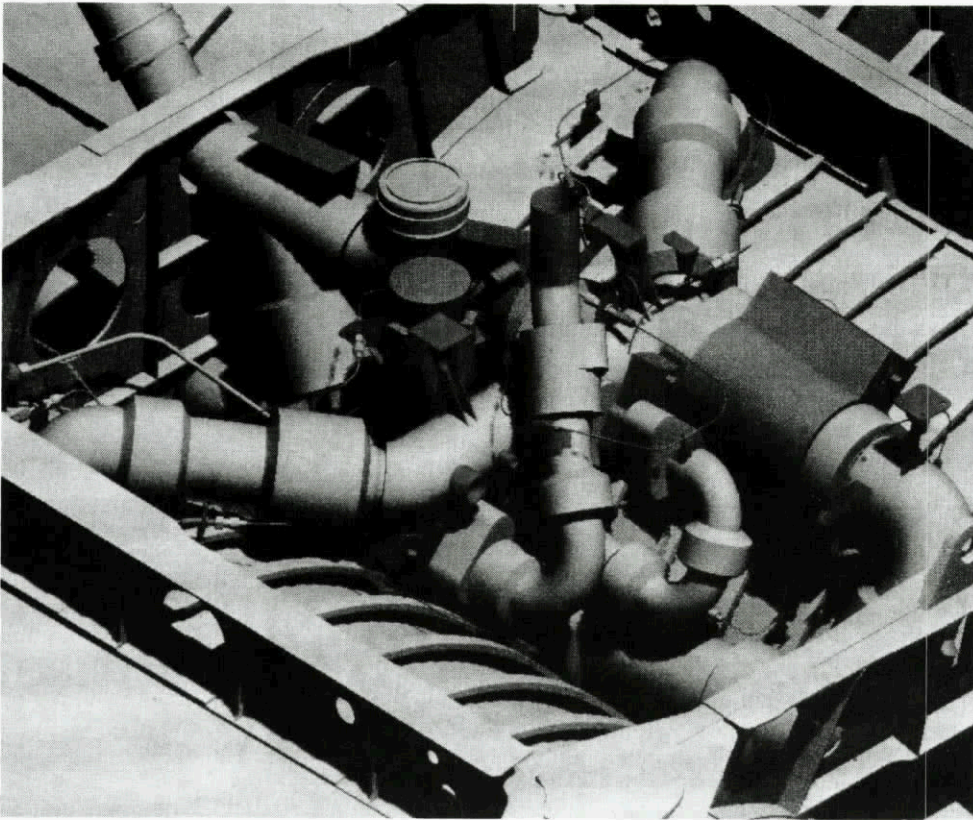
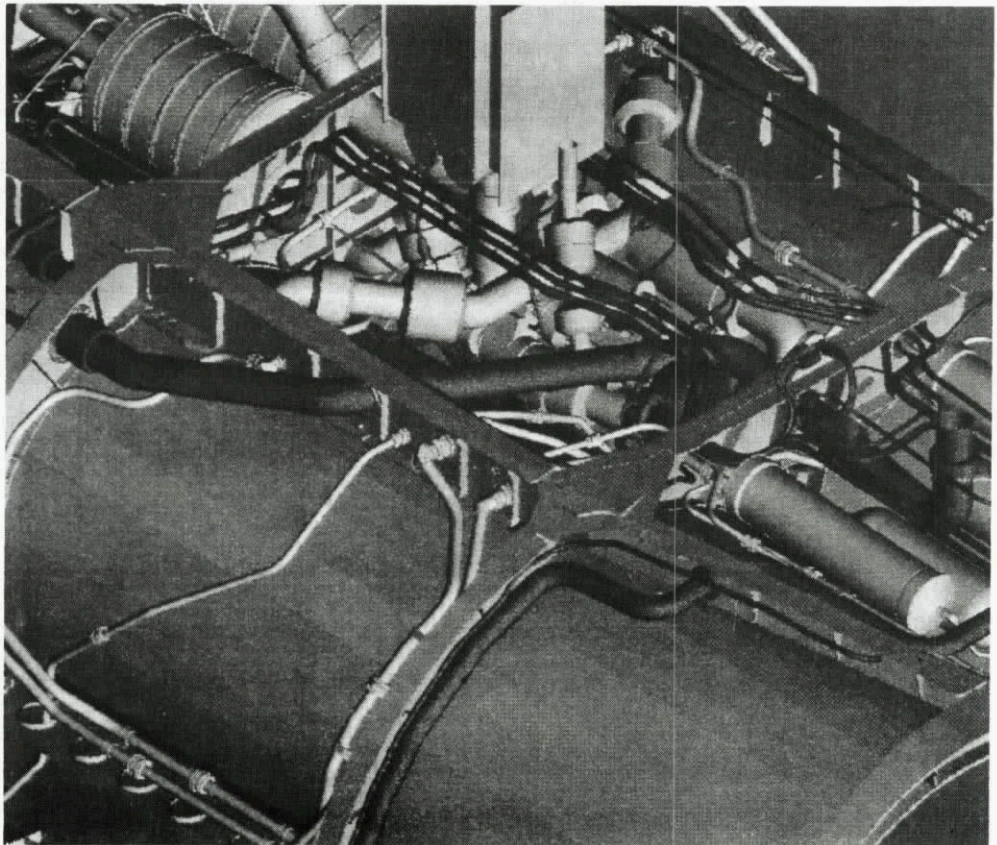
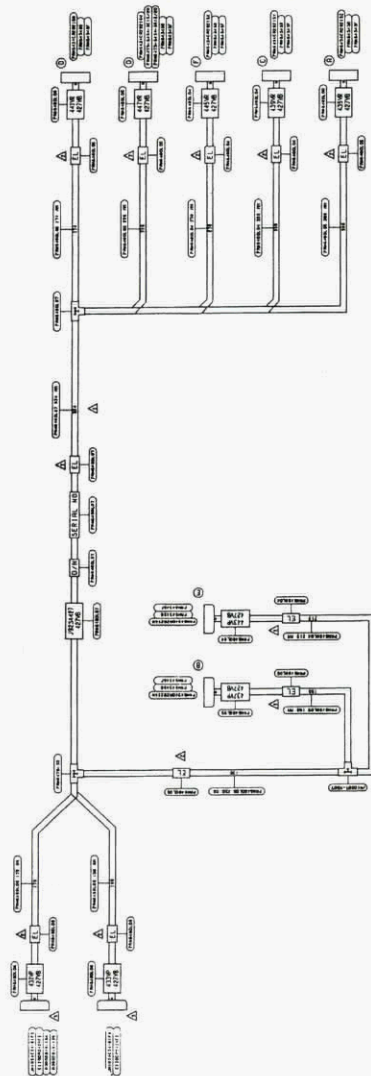

FIG. 5.8 : DMU INTEGRATION - CLASS 3



ELECTRIC LOOM MANUFACTURING DRAWING



ELECTRIC ASSY DRAWING

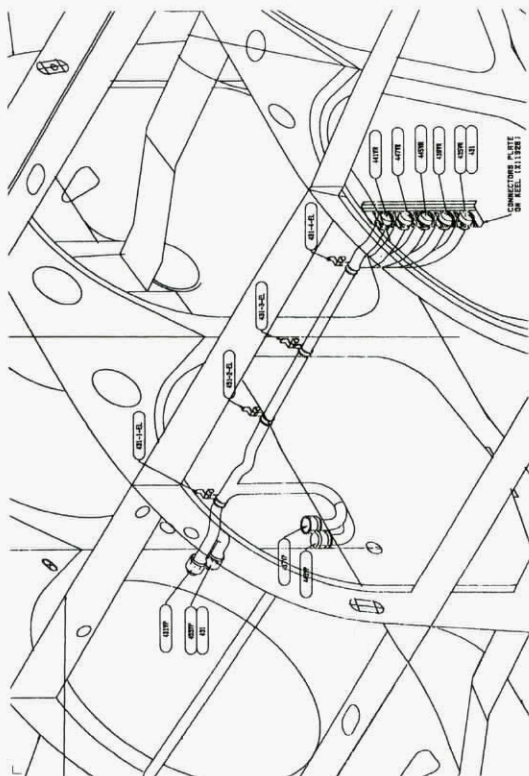

ECS ASSY DRAWING

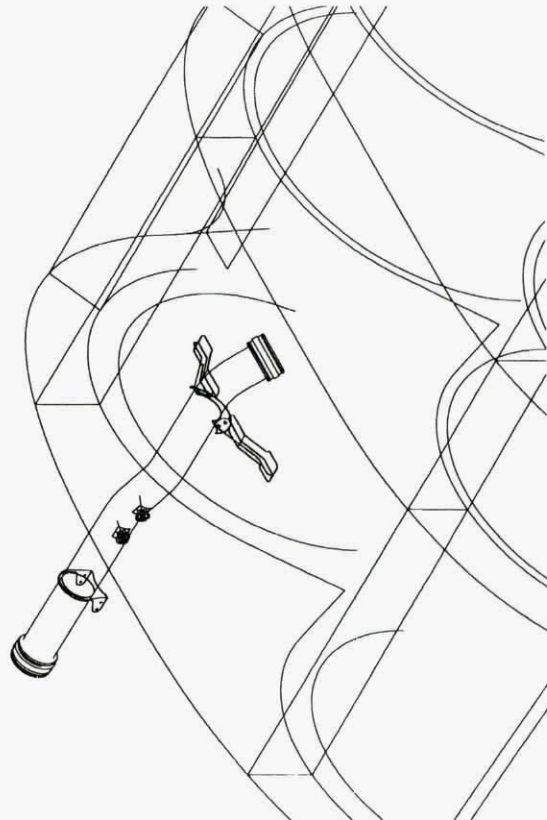

PIPE MANUFACTURING DRAWING

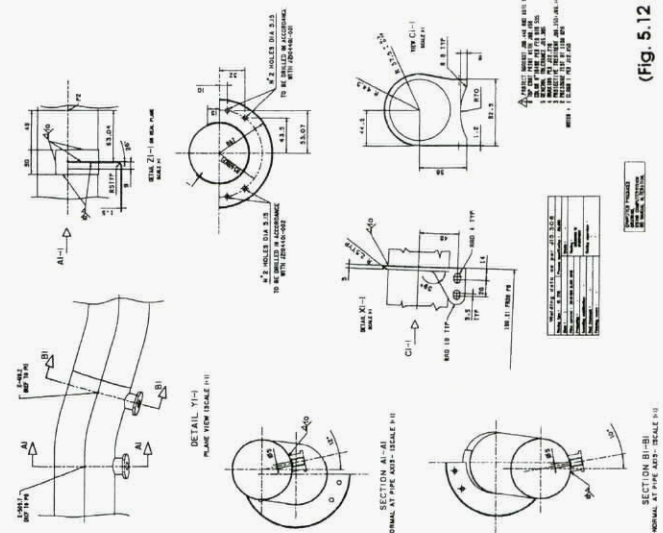

(Fig. 5.12)

DIGITAL PREASSEMBLY

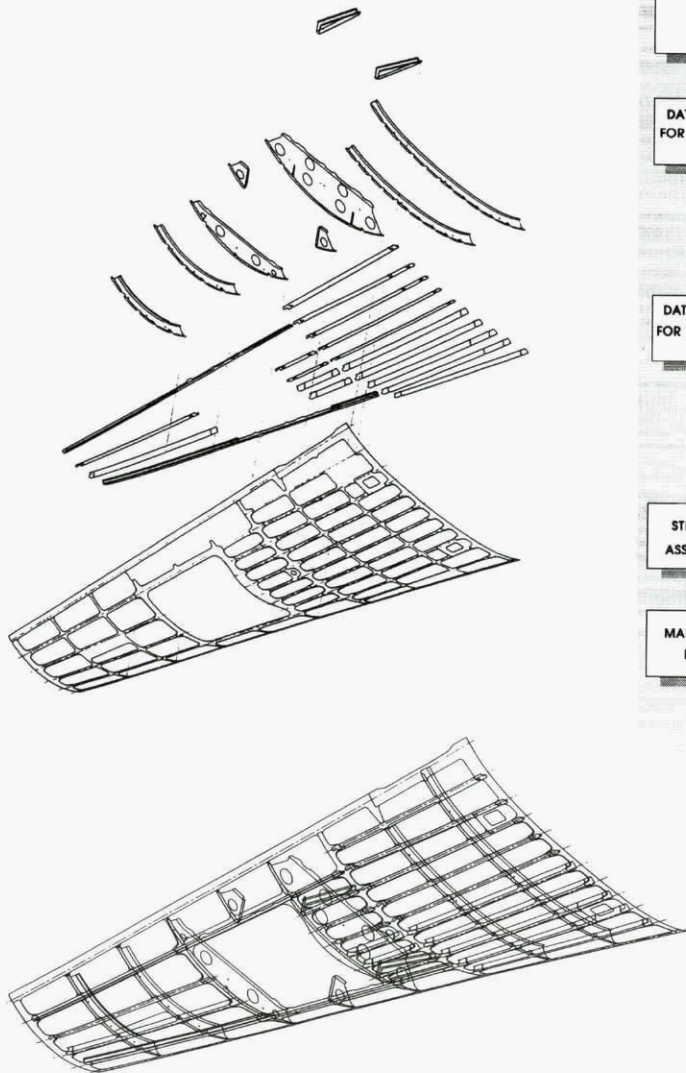

FLOW CHART FOR DIGITAL MOCK - UP (DMU)

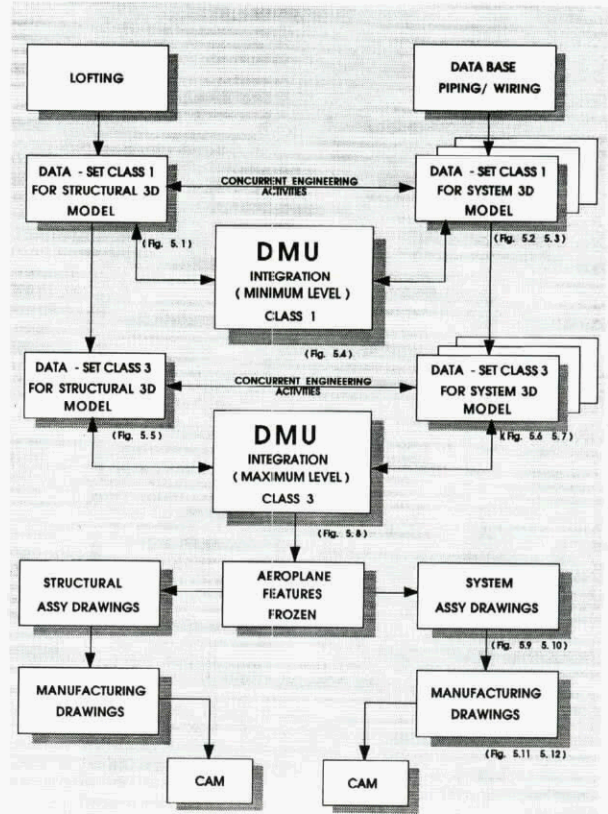

ALEX INTERFACES FLOW CHART

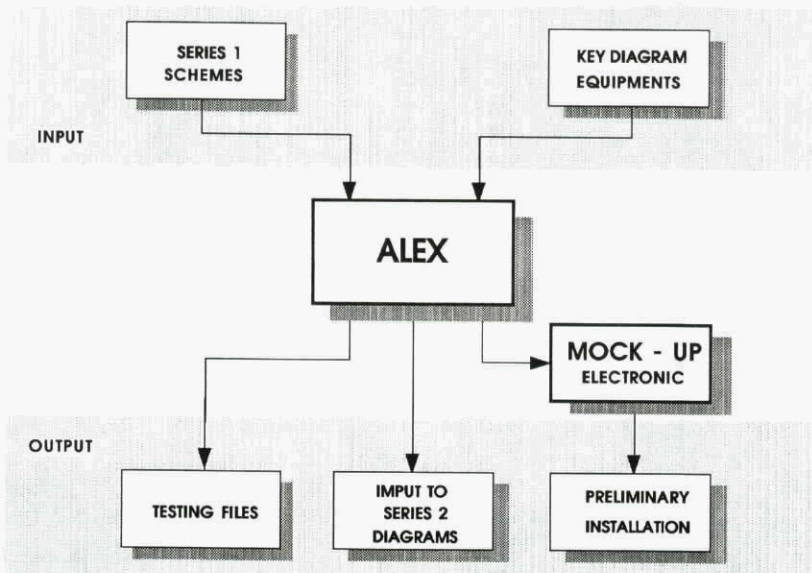

MULTI-DISCIPLINARY COUPLING FOR INTEGRATED DESIGN OF PROPULSION SYSTEMS

C. C. Chamis
NASA Lewis Research Center (M/S 49-8)
21000 Brookpark Road
Cleveland, Ohio 44135, U.S.A.

and

S. N. Singhal
Sverdrup Technology, Inc.
2001 Aerospace Parkway
Brookpark, Ohio 44142, U.S.A.

SUMMARY

Effective computational simulation procedures are described for modeling the inherent multi-disciplinary interactions for determining the true response of propulsion systems. Results are presented for propulsion system responses including multi-discipline coupling effects via (1) coupled multi-discipline tailoring, (2) an integrated system of multi-disciplinary simulators, (3) coupled material-behavior/fabrication-process tailoring, (4) sensitivities using a probabilistic simulator, and (5) coupled materials/structures/fracture/probabilistic behavior simulator. The results show that the best designs can be determined if the analysis/tailoring methods account for the multi-disciplinary coupling effects. The coupling across disciplines can be used to develop an integrated interactive multi-discipline numerical propulsion system simulator.

1. INTRODUCTION

Propulsion phenomena are inherently multi-disciplinary, i.e., the true system response is the coupled effect of all the participating disciplines and the aggregate of the responses and interactions of the system components. Present analyses tend to focus on single-discipline aspects of the phenomena within a local region, e.g., a single component. Suitable approximations are then used to extend these analyses to subsystems and systems.

The performance and reliability of propulsion systems depend on the interaction of their subsystems which, in-turn, depend on the interaction of their respective components (ref. 1). And, the performance of a specific component depends on the coupling effects of the system multi-

disciplinary interaction on the component response (Figure 1). Further, the integrated system response depends on the progressive and interacting influence of the coupled service loads/ environments at all levels from sub-component, to component, to sub-system, to system. Interaction phenomena of interest include flutter, rotor instability, fatigue, flow separation, nonuniform combustion, blade containment, and noise suppression. The determination of aerothermodynamic system performance has traditionally relied on prototype tests while structural reliability has been calculated from field data.

The analysis of propulsion phenomena involves a combination of disciplines including fluid mechanics, thermal sciences, structural mechanics, material sciences, acoustics, electromagnetics, and control theory. The degree of resolution within a specific discipline is determined by the magnitude of local effects and the extent of their region of influence. In order to credibly quantify these local effects, coupled multi-disciplinary methods are needed. Therefore, the objective of this paper is to describe formal coupled multi-disciplinary methods for evaluating the inherent multi-disciplinary interaction in propulsion systems.

2. Multi-disciplinary Coupling Methods

Recent advances in the computational simulation of fluids, thermal, structural, material, acoustic, and electromagnetic response and computational controls make it timely to consider the development of coupled multi-disciplinary computational simulation methods. These coupling methods provide the formalism to generate the terms shown in the array in Table 1, as would be described extensively in section 2.7. Single discipline simulations produce the

diagonal sub arrays while coupled multi-disciplines produce the off-diagonal terms. Considerable infrastructure is available for single disciplines as was mentioned previously. In this section, we describe how available (existing) infrastructure is used to simulate the multi-discipline coupled response of various propulsion components which are subjected to a multitude of simultaneous loads.

2.1 Coupled Multi-discipline Tailoring

- A coupled multi-disciplinary composite-materials/hygral/thermal/structural/acoustic/electromagnetic analysis/tailoring code, CSTEM (ref. 2) can be used to tailor the single or multi-discipline responses of propulsion structures. CSTEM was used for tailoring a multi-layered composite fan blade subjected to multi-discipline loads (Figure 2). The composite materials behavior was analyzed via an integrated composite analyzer (ref. 3) starting from the lowest composite scale (fiber/matrix constituents) to higher scales (ply, laminate) using composite micro-mechanics and laminate theories (Figure 3). The laminate scale materials behavior is used to determine global structural response using finite element analysis. The global structural response is then decomposed to the lower composite scales using laminate theories and composite micro-mechanics. A nonlinear material characterization model (Figure 4) is used at the constituents scale to account for the effect of service environments. The results of the tailoring of the fan blade for individual disciplines are shown in Figure 5. Two cases, also shown at the bottom of Figure 5, are for the coupled multi-disciplines: (1) coupled composite-mechanics/heat-transfer/vibrations case - the effect of heat transfer loads is carried through the temperature profiles at all composite scales that in-turn affect the materials behavior and thus the vibration response of the blade, and (2) coupled composite-mechanics/heat-transfer/vibrations/acoustic responses - the effect of heat transfer loads is carried through the temperature profiles at all composite scales that in-turn affect the materials behavior including acoustic characteristics and the vibration response of the blade. Thus, the acoustic response includes all the interaction effects, namely: (i) heat-transfer loads, (ii) thermal, mechanical, and acoustic resistance of the material, and (iii) blade vibration characteristics. This

provides a wealth of information such as the laminate configurations required for tailored responses of different disciplines, which can sometimes be opposite to each other, as is evident from Figure 5. The off-diagonal terms in Table 1 can be developed by evaluating the other disciplines at the optimum design.

2.2 Multi-Objective Optimization - This example demonstrates the capability to optimize the structure response due to several disciplines simultaneously. Figure 6 (ref. 4) shows a candidate composite structure optimized for single and multi-objective functions. The best design is obtained when the multi-objective function is used.

2.3 Integrated System of Multi-disciplinary Analysis - A nonlinear materials behavior simulator (ref. 3) and a specialty finite element code (ref. 5), and the coupled multi-discipline code CSTEM (ref. 2) were integrated for simulating the fatigue behavior of a multi-layered hot and wet composite panel acoustically excited by an adjacent vibrating hot panel (Figure 7), typical of aircraft components. Figure 8 shows that the fatigue life of the acoustically excited panel can be increased substantially by keeping the off-axis plies on the outer surface of the laminate. The important point is that the coupled multi-disciplinary response of composite structures can be computed for best designs, with no surprises when operating in real-life service environments since the analysis captures the various multi-disciplinary coupling effects (interactions).

2.4 Coupled Material-Behavior/Fabrication-Process Tailoring - The fabrication process of a composite laminate can be tailored for desired optimum single discipline or multi-discipline objective value via a Metal Matrix Laminate tailoring code, MMLT (ref. 6). The results in Figure 9 show the correct laminate characteristics (extensional stiffness, compressive load capacity, bending stiffness, and bending load capacity) that can be attained for individual stiffness or load maxima as well as for concurrent stiffness/load maxima.

2.5 Sensitivities via Probabilistic Methods - The sensitivities of the effective stress for a second stage turbine blade at two different blade locations were assessed via a probabilistic structural behavior simulation (ref. 7). The importance factors for five dominant variables at different blade locations were found to be different and with different

importance ranking (Figure 10). These are respective off-diagonal terms in the array, Table 1.

2.6 Coupled Materials/Structures/Fracture/probabilistic behavior simulator - A progressively more inclusive integration of the various discipline-specific simulators is made possible with the existing infrastructure at the NASA Lewis Research Center. The results of a coupled materials/structures/fracture behavior of a rotor blade including interactions due to uncertainties in various design variables at their lowest levels (called primitive variables) are shown in Figure 11. The true direction of the fracture path is decided, not by a specific analysis, but by the above-mentioned coupled effects.

2.7 Multi-discipline Sequential Optimization - An integrated simulator for propulsion systems will entail potentially very large number of coupled (interrelated) variables. Clearly, in addition to coupled multi-discipline simulators discussed above, innovative approaches are needed to reduce the dimensionality of the system description while still retaining the essential system behavior. The viable approaches include sequential iterations between disciplines, specially-derived system matrices, and coupling at the fundamental equation level. The coupling across disciplines in a concurrent multi-disciplinary formulation can be represented by coupling relations. The coefficients (elements) in these relations define the coupling of a specific variable from one discipline with respective variables from interacting disciplines (Table 1).

Perturbation of the variables in the coupling relations provide a measure of the sensitivity of the interacting disciplines to this perturbation. A priori description of this sensitivity relationship enhances the computational simulation in several respects: (1) scoping the degree of coupling, (2) identifying the interacting disciplines, (3) resolving time/space scales, (4) selecting time/space scale for loosely coupled interacting discipline intervention during the solution processes, (5) deciding on a solution strategy, and (6) imposing convergence criteria.

Four different methods are being pursued for defining and deriving sensitivity relations. These are: (1) heuristic - based on available

traditional single discipline approaches and expert opinion, (2) multi-discipline sequential optimization - based on determining the primitive variables for optimum response within a single discipline, determining the response for optimized primitive variables for all coupling disciplines, and repeating the process for each discipline of interest, (3) probabilistic evaluation - based on determining the sensitivities of multi-disciplinary response to interrelated primitive variables, and (4) fundamental coupled formulation - based on mixed-field finite elements coupling the primitive equations. The results for the multi-discipline coupling of the propulsion component responses using these techniques are being acquired. These results will then be processed to compute the coupling coefficients of the specialty multi-disciplinary matrices.

3. Use of Multi-Parallel Processor Computers

The examples discussed above are currently scientifically/technically feasible using the existing computer hardware. The computer systems are becoming more sophisticated and more powerful with continually increasing processing speeds through parallelization. This concurrent development of the computer hardware would reduce the turn-around time, necessary for modeling the whole propulsion systems including all the interactions. However, due emphasis must be placed on innovative coupled analysis/tailoring schemes to decipher the importance of the various interactions for propulsion systems of interest, as demonstrated in section 3 above. Figure 12 (ref. 8) shows the architecture of the multi-discipline coupling of structural-analysis and reliability methods.

4. Numerical Propulsion System Simulator

The existing infrastructure can be used to develop an integrated interactive multi-disciplinary computational simulator. Such a system is under development and it is called Numerical Propulsion System Simulator (NPSS) shown schematically in Figure 13 (ref. 1). NPSS would allow comprehensive simulation of the entire propulsion concepts and designs before committing to hardware. It would include recent multi-disciplinary computational tailoring models to allow the selection of better, cheaper, and faster propulsion designs for desired performance. Also, reliability-based

propulsion design would be possible with the recent progress in probabilistic methods that account for all the uncertainties inherent at various levels of the propulsion systems. This will greatly reduce (1) the design space for new systems, (2) our dependence on extensive hardware testing for proof-of-concept and system integration demonstrations, and (3) the need for testing and identifying potential operational problems early in the design process.

The NPSS simulator will enable the incorporation of new methodologies such as concurrent engineering into the propulsion design process. This will provide the capability to conduct credible, multi-disciplinary analyses/tailoring of new propulsion concepts and designs at true cost and time minimums.

In essence, the NPSS simulator will include all the key enabling technologies for integrated multi-disciplinary analysis and tailoring of propulsion systems. The existing infrastructure will be used while maintaining flexibility to utilize emerging massively parallel computing hardware platforms. The simulator architecture as shown in Figure 14 consists of the simulator executive controlling the various simulation codes, libraries, data management facilities, controls, graphic visualization facilities, information systems, and expert systems. A schematic of the multi-discipline coupling for propulsion components in Figure 15 shows (1) the interactions between the aero/heat-transfer effects and the mechanical clearance of the structures, (2) the interactions between the aero system response and the inlet fan map, (3) the coupling of structures system response and fan loads, and (4) the coupled aero blade load and blade tip clearance effect.

5. CONCLUDING REMARKS

Computational simulation is natural and most cost-effective way to evaluate multi-discipline coupling. Concurrent development of multi-disciplinary modular stand-alone transportable computer codes has provided the infrastructure to computationally simulate multi-discipline coupling. The coupling across disciplines in a concurrent multi-disciplinary formulation can be represented by coupling relations. The coefficients in these coupling relations can be determined by various techniques including sequential optimization, probabilistic

approaches, and coupled fundamental formulations. The results show that coupling effects can be modeled using existing codes. The coupling methods combined with other suitable infrastructure are being used for developing a numerical propulsion system simulator for designing/analyzing propulsion systems.

REFERENCES

1. Nichols, L. D. and Chamis, C. C., "Numerical Propulsion System Simulation: An Interdisciplinary Approach", NASA TM 105181, Sept., 1991.
2. Hartle, M., et. al., "CSTEM User's Manual", NASA Document, 1990.
3. Murthy, P. L. N. and Chamis, C. C., "Integrated Composite Analyzer (ICAN). Users and Programmers Manual", NASA TP-2515, 1986.
4. Saravanos, D. A. and Chamis, C. C., "Multi-objective Shape and Material Optimization of Composite Structures Including Damping", NASA TM 102579, April 1990.
5. Nakazawa, "MHOST User's Manual", NASA Document, 1987.
6. Morel, M. R., Saravanos, D. A. and Chamis, C. C., "Tailored Metal Matrix Composites for High-Temperature Performance", NASA TM 105816, 1992.
7. "Probabilistic Structural Analysis for Select Space Propulsion System Structural Components", Annual Report by SwRI, Rocketdyne, Univ. of Arizona, MARC Analysis Corp. and Columbia Univ. for NASA LeRC, Contract NAS3-24389, 1986.
8. Sues, R. H., Chen, H.-C., Twisdale, L. A., Chamis, C. C. and Murthy, P. L. N., "Programming Probabilistic Structural Analysis for Parallel Processing Computer", AIAA/ASME/ASCE/AHS 32nd Structures, Structural Dynamics, and Materials Conference, Part 2, AIAA, 1991, pp. 1243-1253.

Table 1 - Coupled Multi-discipline Representation for Aerospace Propulsion Systems

$\left\{ \begin{array}{l} (A) \\ (T) \\ (S) \\ (M) \\ (F) \\ (P) \\ (C) \end{array} \right\}$	=	$\left[\begin{array}{cccccccc} [A_A^A] & [T_A^T] & [S_A^S] & [M_A^M] & [F_A^F] & [P_A^P] & [C_A^C] \\ [A_T^A] & [T_T^T] & [S_T^S] & [M_T^M] & [F_T^F] & [P_T^P] & [C_T^C] \\ [A_S^A] & [T_S^T] & [S_S^S] & [M_S^M] & [F_S^F] & [P_S^P] & [C_S^C] \\ [A_M^A] & [T_M^T] & [S_M^S] & [M_M^M] & [F_M^F] & [P_M^P] & [C_M^C] \\ [A_F^A] & [T_F^T] & [S_F^S] & [M_F^M] & [F_F^F] & [P_F^P] & [C_F^C] \\ [A_P^A] & [T_P^T] & [S_P^S] & [M_P^M] & [F_P^F] & [P_P^P] & [C_P^C] \\ [A_C^A] & [T_C^T] & [S_C^S] & [M_C^M] & [F_C^F] & [P_C^P] & [C_C^C] \end{array} \right]$	$\left\{ \begin{array}{l} (A) \\ (T) \\ (S) \\ (M) \\ (F) \\ (P) \\ (C) \end{array} \right\}$		
		System response variables		System definition/characteristics and coupling relationships	System development and service parameters
		<p>A Aero T Thermal S Structural M Material F Fabrication P Performance C Cost</p>			

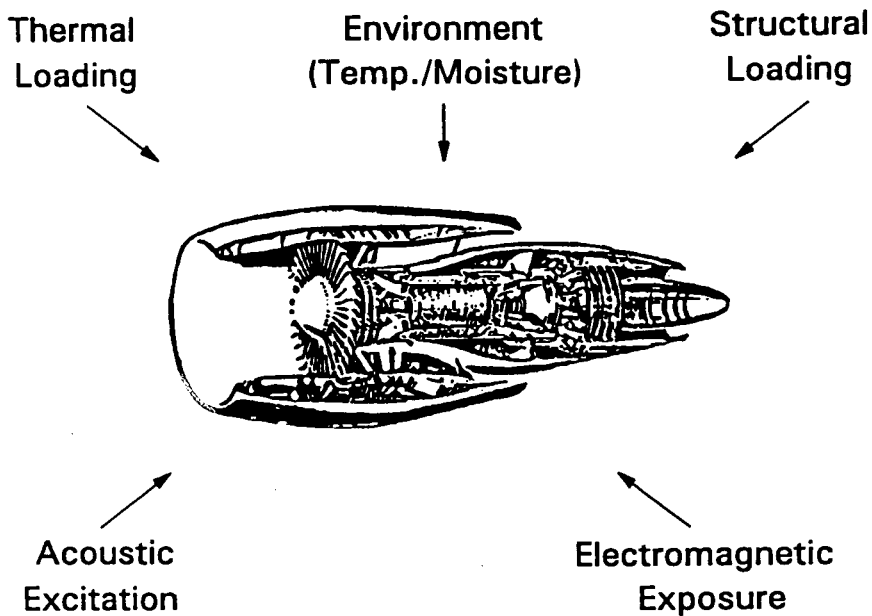

Figure 1 - Engine Components Under Service-Environment Loadings

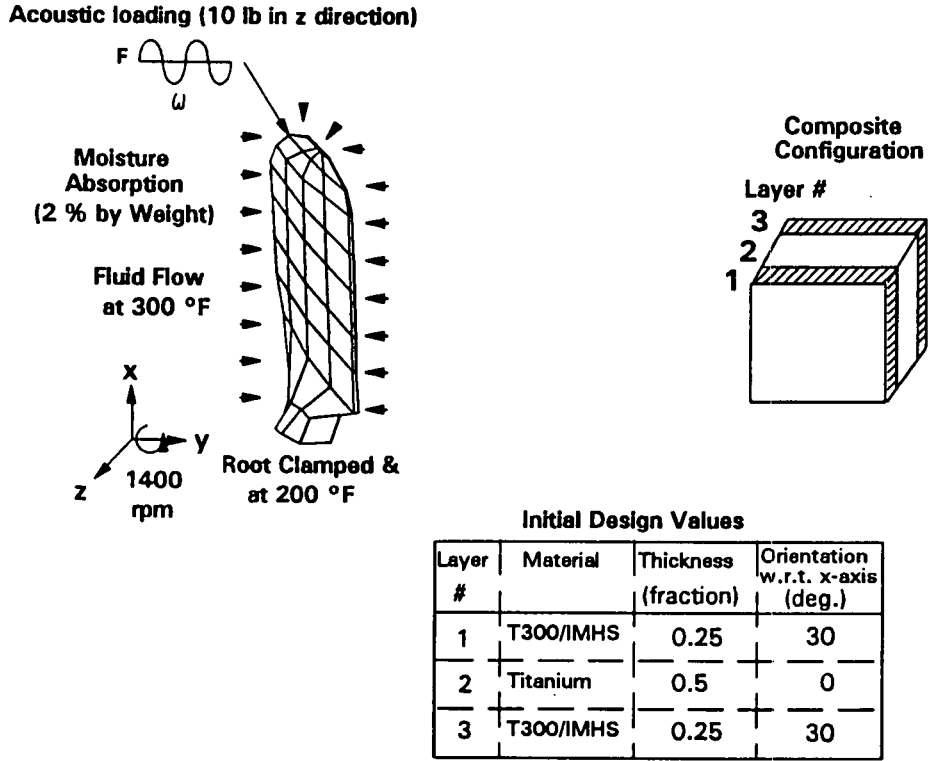

Figure 2 - Multi-material Multi-layered Composite Fan Blade: Initial Design under Multi-disciplinary Loadings

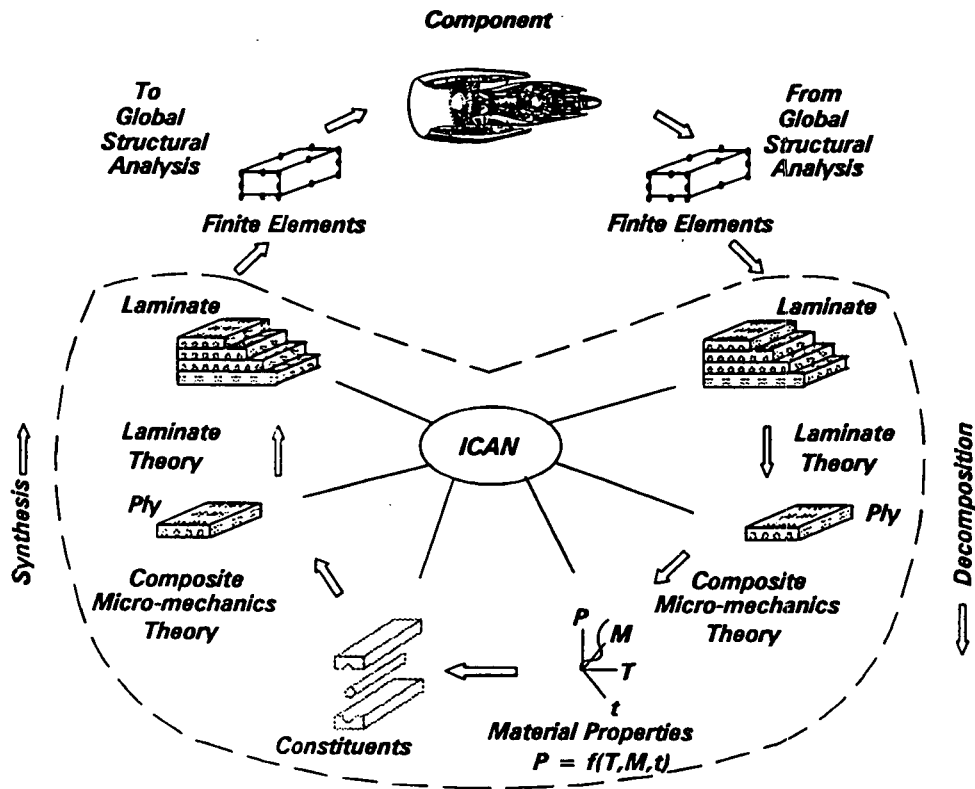

Figure 3 - Integrated Composite Analysis (ICAN)

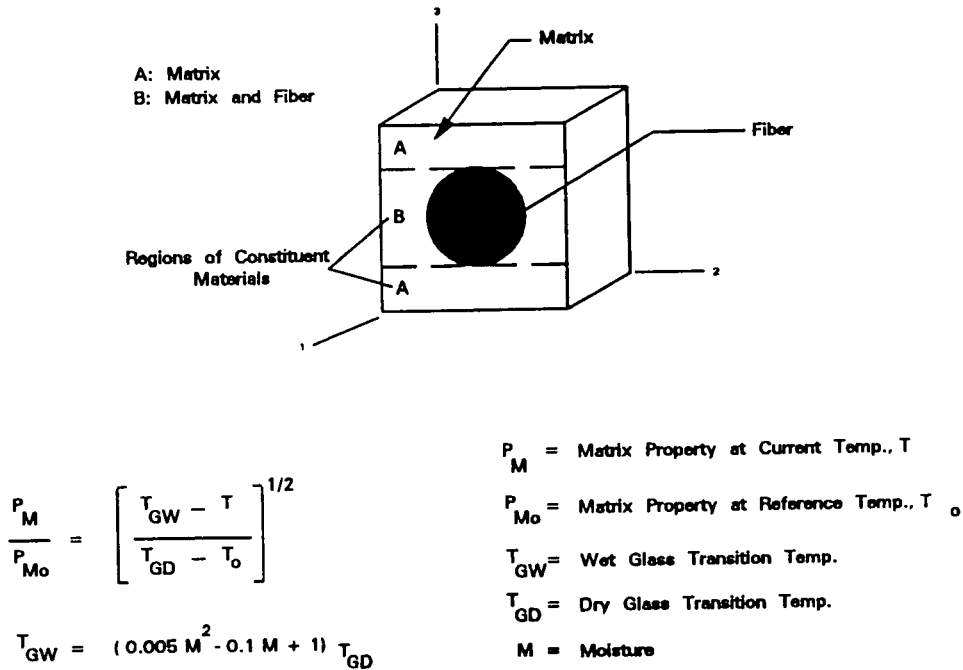

Figure 4 - Regions of Constituent Materials and Nonlinear Material Characterization Model

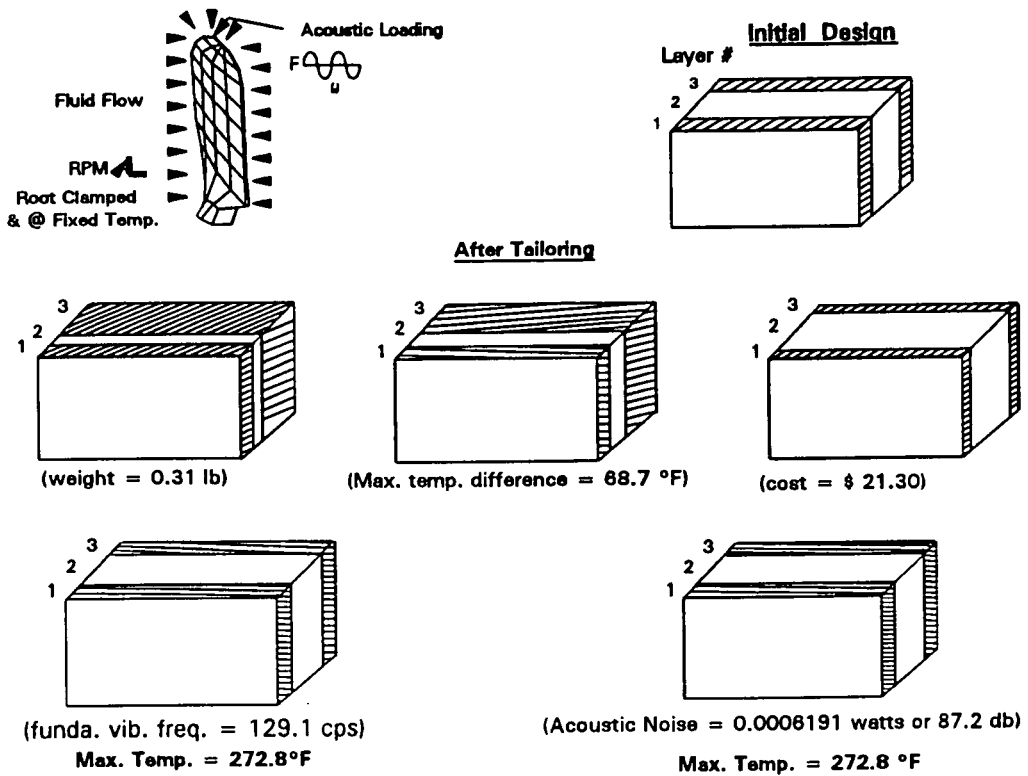

Figure 5 - Multi-material Multi-layered Composite Fan Blade:
 Tailored Designs Under Multi-disciplinary Loadings

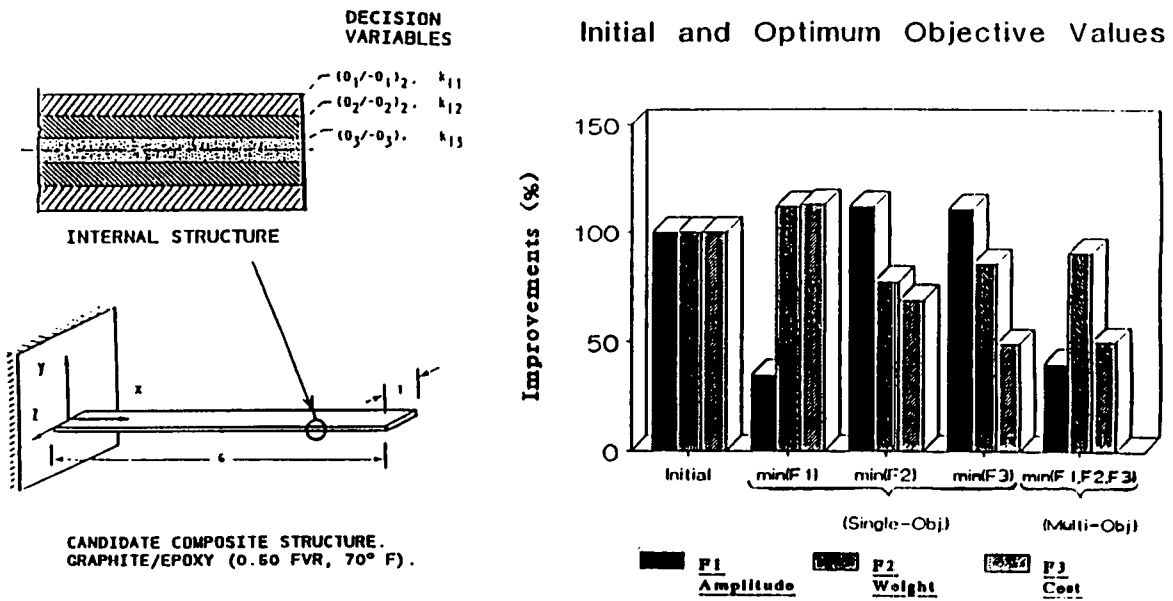

Figure 6 - Multi-Objective Optimization

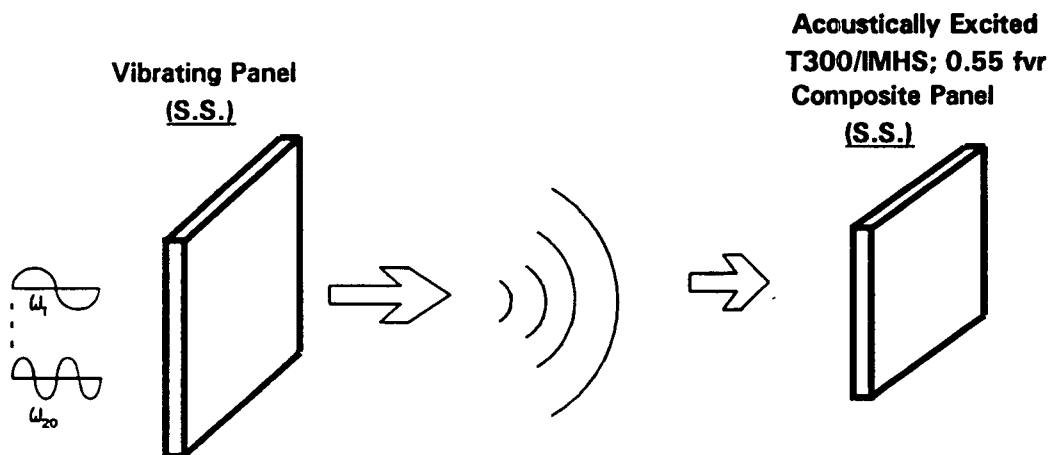

Figure 7 - Acoustically Excited Composite Panel

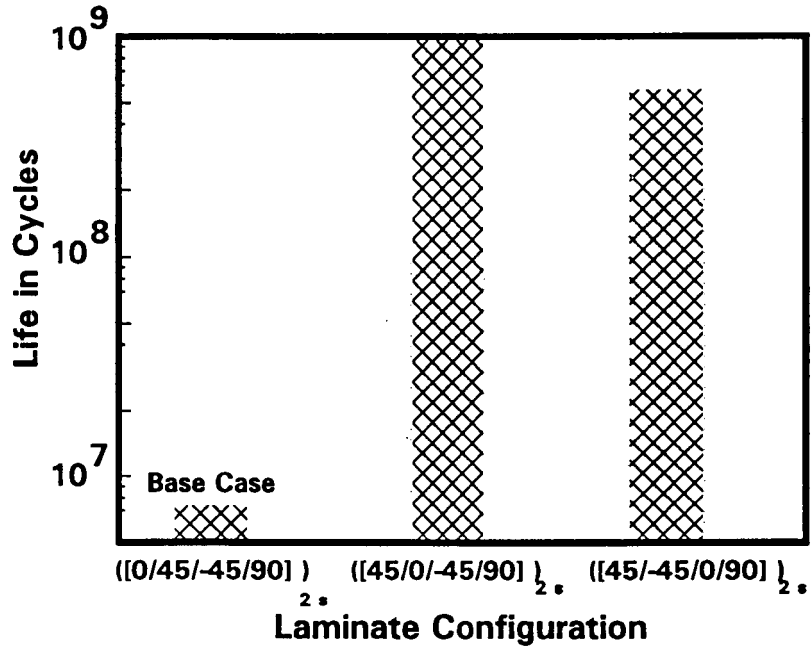

Figure 8 - Coupled Composite-materials/hygral/thermal/structural/acoustic simulation: Effect of Laminate Configuration

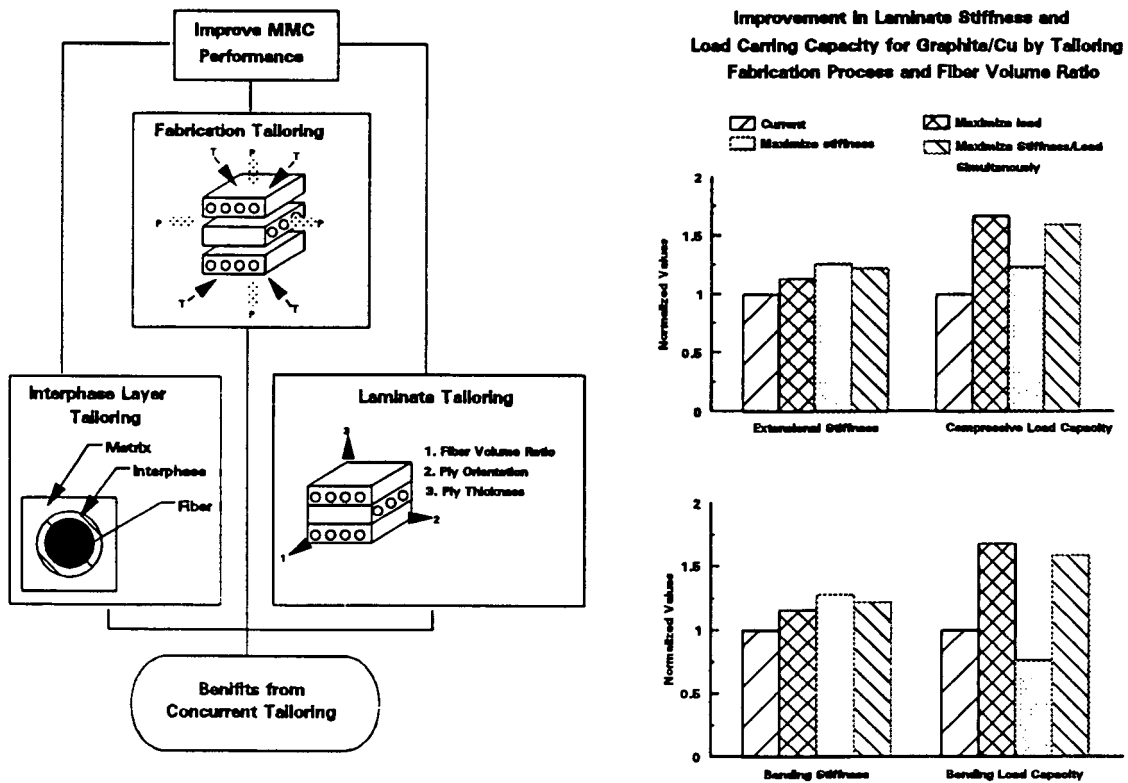

Figure 9 - Metal Matrix Laminate Tailoring to Improve Load Carrying Capacity

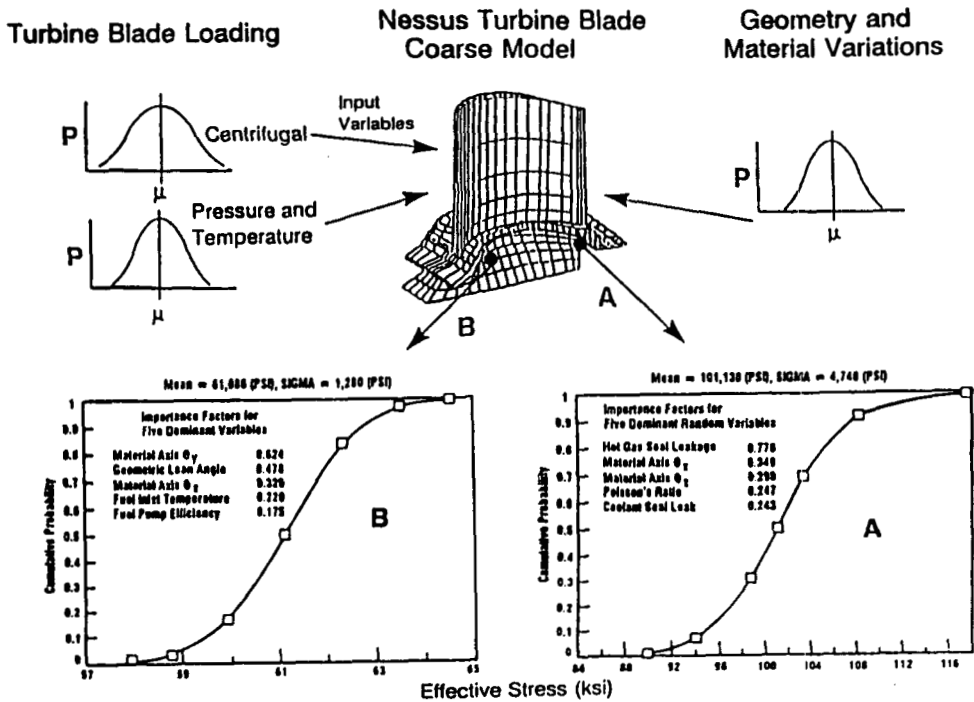
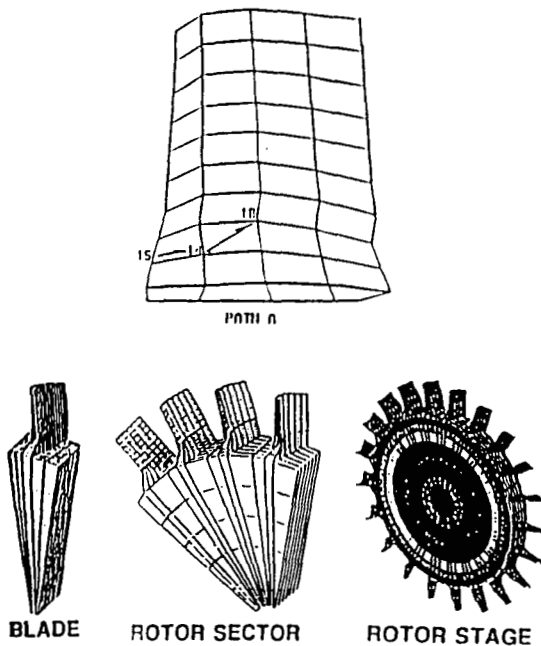

Figure 10 - Probabilistic Component Stress and Sensitivities Analyses



Some Details of Current Application of NASA's PSAM code.

(Probabilistic Crack Initiation and Growth)

- 0 Coarse Mesh (55 nodes, 40 elements)
- 0 Two-D FEM Modeling (6 d.o.f. at node)
- 0 Limited Response Variables (100)
- 0 CPU time on CRAY (10000 sec.)
- 0 Turnaround time on CRAY (1 - 2 weeks)

If the Phase I Success is carried over Successfully to Phase II We will be able to

- 0 Utilize Multiple Levels of Parallelism in Large Scale Structures
- 0 Solve for Large No. of Structural Response Variables
- 0 Opt for 3-D/Finer Mesh for better Accuracy
- 0 Achieve High Degree of Cost Effectiveness in Risk/Reliability Assessment

Figure 11 - Fracture Path of a Rotor Blade

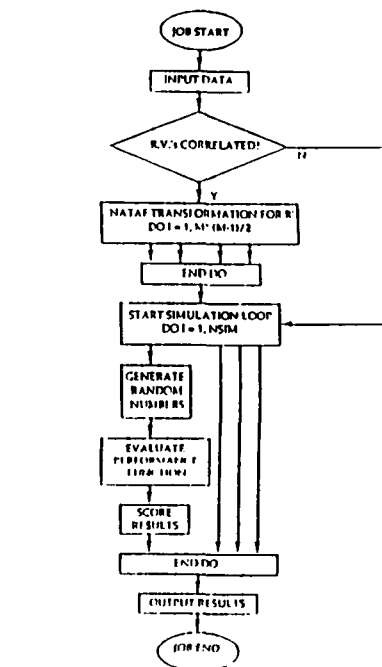
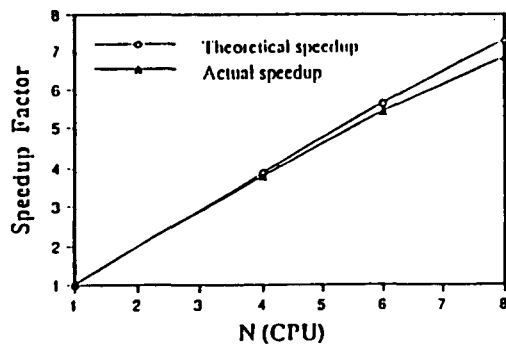
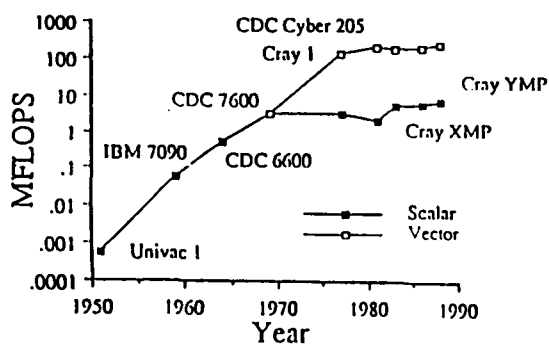

PARALLEL COMPUTING CODE FOR PSM

Figure 12 - Scientific/Technical Merit/Feasibility

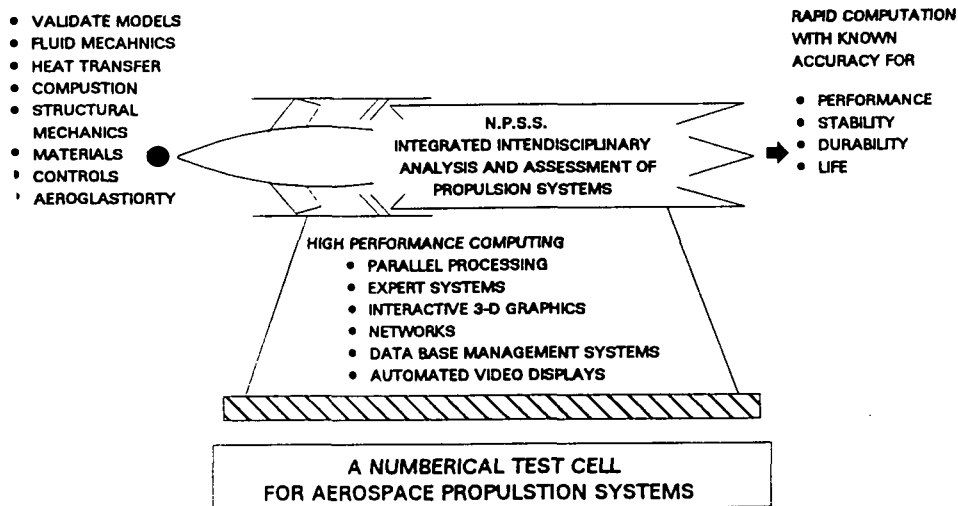

Figure 13 - Numerical Propulsion System Simulator

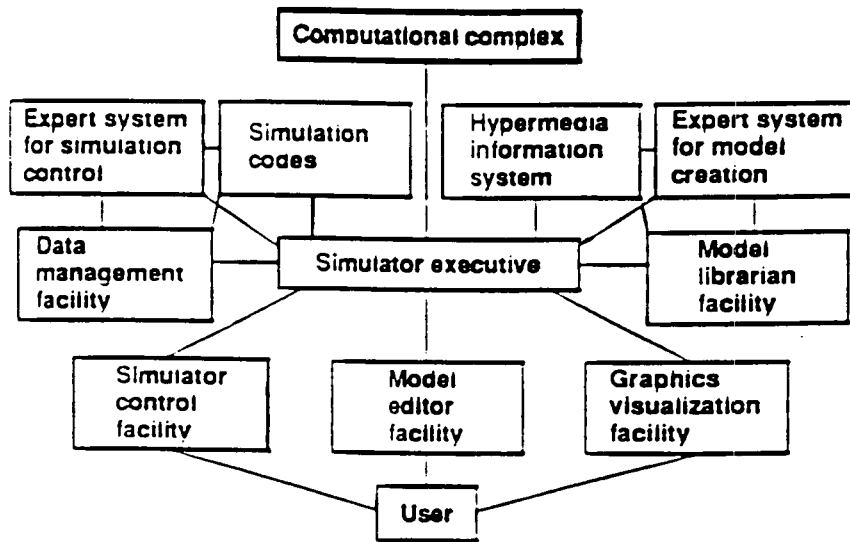

Figure 14 - Simulator Architecture

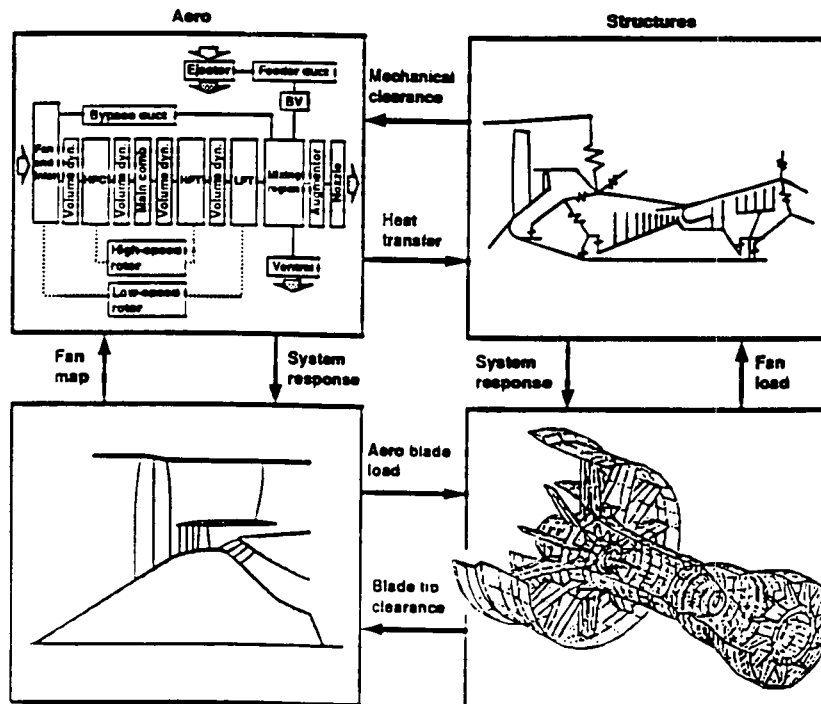

Figure 15 - Simulator Models

**TENDANCES DANS LA METHODE DE CONCEPTION
 DES CELLULES D'AVION MILITAIRE**
 (TRENDS OF DESIGN METHODOLOGY OF AIRFRAME)

par

C. Petiau
 Dassault Aviation
 78 Quai Marcel Dassault
 92214 St. Cloud
 France

RESUME

Nous rappelons que l'organisation de la conception des cellules d'avion est liée aux performances des outils dont on dispose. Ces performances conditionnent le nombre et la nature des itérations du projet.

Nous présentons et analysons l'organisation d'aujourd'hui qui est construite autour des moyens de CAO, de calcul et d'optimisation mathématique disponibles.

La conception se fait par une première définition, suivi d'une vérification expérimentale, avec un rôle clef pour les essais en vol. On en déduit la définition définitive qui est vérifiée à l'aide des modèles de calcul recalée sur les essais.

Nous examinons ensuite les facteurs d'évolution de cette organisation dans le futur que sont :

- la disposition d'"Historiques" de l'ensemble des données du processus de conception,
- la CAO paramétrée et l'optimisation de forme,
- l'optimisation multidisciplinaire,
- la conception par "Feature",
- le progrès des méthodes de calcul.

Nous concluons en soulignant l'intérêt qu'auraient les industriels de l'aéronautique, les fournisseurs de logiciel et les chercheurs à se concerter pour développer les méthodes de conception du futur.

ABSTRACT

We shall first remind that organization of airframe design is directly linked to the performances of available tools. As a matter of fact, they condition the number and nature of project iterations.

We present and analyse the organization which should nowadays be recommended in view of the means of CAD, computation and mathematical optimization at our disposal.

This leads to a first design, followed by experimental verifications with a key role for flight tests. The final design is checked with the help of calculations models calibrated on tests.

Then we shall examine the new tools which are the factors of future evolution of design methodology :

- To dispose of "Design History" corresponding to the whole data of the process
- Parametric CAD and Shape optimization
- multidisciplinary optimization
- "Feature" Design
- Improvement of computation methods

As a conclusion we insist on the fact that aircraft manufacturers, CAD suppliers and scientific searchers will be well advised to create a dialogue as to future design methodology.

1 - INTRODUCTION

La méthode de conception est l'art de mettre en oeuvre l'ensemble des travaux spécialisés conduisant à la définition, la réalisation et la qualification d'un produit. Elle détermine la nature exacte et l'enchaînement des tâches à mener. Elle est directement dépendante des moyens disponibles (outils de CAO, Moyens de calcul, Technologie, etc...).

La tendance est souvent de rattacher la décomposition des tâches d'étude à celle du produit matériel ; ce qui aboutirait pour une cellule d'avion à la décomposition suivante :

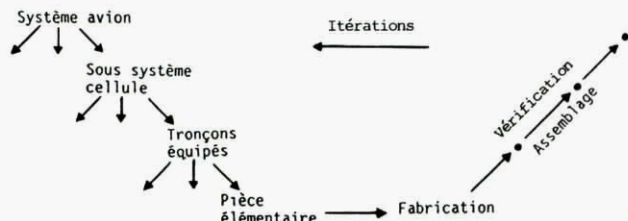

Dans une situation idéale, la définition de chaque niveau de sous-produits se ferait à partir des spécifications reçues du niveau supérieur, et en fonction des potentialités des niveaux inférieurs supposées connues.

La fabrication du produit et sa vérification à chaque niveau de sous-produit se ferait en ordre inverse de la conception.

En pratique cette organisation ne peut fonctionner qu'avec des itérations de deux types :

- Itérations d'études entre un niveau et ses niveaux inférieurs pour appréhender la pertinence des spécifications et pouvoir définir les interfaces entre les sous-produits de même niveau.
- Itérations de vérifications expérimentales. Elles nécessitent la fabrication et l'essai de "prototypes" de sous-produits et de l'avion lui-même.

Le nombre et la nature de ces itérations est étroitement dépendant :

- du degré d'innovation demandé au produit,

- du contexte technologique dans lequel on se trouve, en particulier :
 - . la flexibilité des outils de définition (CAO) dont on dispose,
 - . la fiabilité et de la flexibilité des outils de simulation numérique,
 - . la disponibilité de moyen d'essais,
 - . la disponibilité d'outil d'optimisation mathématique.

Nous allons illustrer ce propos en analysant l'organisation de la conception de la cellule d'un avion de combat avec les moyens disponibles aujourd'hui.

On examinera ensuite quelles sont les évolutions possibles de ces moyens qui influenceront l'organisation de la conception des cellules dans le futur.

2 - ANALYSE D'UNE ORGANISATION ACTUELLE DES ETUDES DE STRUCTURE

Cette organisation correspond au développement d'un avion de combat "classique" aujourd'hui (Emploi des matériaux composites à grande échelle, commandes de vol "électriques").

Parmi les moyens dont on dispose, ceux qui conditionnent le plus l'organisation sont :

- un outil de CFAO efficace (CATIA) capable d'alimenter une base de donnée géométrique commune à tous les niveaux (y compris la fabrication) :
- un outil d'analyse et d'optimisation du dimensionnement (ELFINI), couplant directement les calculs d'aéroélasticité, des charges, de la résistance des matériaux, etc... (voir référence 1). Cet outil est directement connecté au système CATIA par son mailleur "topologique". Il permet d'analyser à faible coût et délais un très grand nombre de variantes de la définition, grâce à l'association :
 - . de l'optimisation structurale qui fait que les échantillonnages deviennent les sorties des calculs au lieu d'être des données à fournir,
 - . du mailleur topologique qui rend les données du maillage relativement peu sensible aux variations de géométrie,
 - . de l'existence d'un "Historique" de l'ensemble des données des maillages et des calculs, ce qui permet de les rejouer dans les itérations en ne modifiant que celles qui changent.
- La maîtrise globale des technologies qu'on se propose d'utiliser ; ce qui implique la disponibilité d'un Standard de conception (Design Handbook) validé, avec les règles de calcul associées.

La logique de développement de la structure doit aussi tenir compte du niveau de fiabilité des méthodes de calcul et des moyens d'essais disponibles, entre autre :

- de la précision moyenne des calculs théoriques d'aéroélasticité et de charges ; elle ne devient bonne qu'après un recalage sur les essais en vol ;

- de la bonne précision, en principe, des calculs d'élasticité (calcul des champs de contrainte en fonction des charges) avec la possibilité de faire des "zoom" d'analyse locale non linéaire aussi précis qu'il est nécessaire, mais avec un risque omniprésent d'erreur humaine :
 - . dans les maillages, et dans leur représentativité de la structure réelle,
 - . dans l'analyse des résultats,
 - . dans la gestion des impasses sur les calculs raffinés.
- de la faiblesse des critères théoriques de contraintes admissibles (en statique pour les composites, en fatigue pour les métalliques). Ils nécessitent une calibration expérimentale extensive couvrant l'ensemble des configurations autorisées par le Standard de Conception.

Dans ce contexte, l'organisation de la conception des structures est menée avec l'enchaînement présenté planche 1.

Les grandes lignes de chaque étape sont les suivantes :

- AVANT PROJET

Dans cette phase la définition de la structure est implicite, son influence est prise en compte par des formules empiriques.

- CONCEPTION GENERALE DE LA CELLULE EQUIPEE

A partir d'une forme extérieure donnée on définit plus précisément l'implantation des principaux équipements, du poste de pilotage, des réservoirs, etc..., cela en association étroite avec un dessin général de structure (dit "Voiles et Planchers"), donnant le maillage général et les grands choix technologiques (dont les matériaux).

Le dimensionnement général de la structure est réalisé en parallèle du dessin général, il comporte :

- la réalisation d'un modèle élément fini global (Figure 1) qui sert de base à tous les types d'analyse qui suivent :
 - . les calculs d'aéroélasticité statique et de flutter,
 - . le calcul des charges,
 - . l'analyse globale de la résistance mécanique en statique et en fatigue.

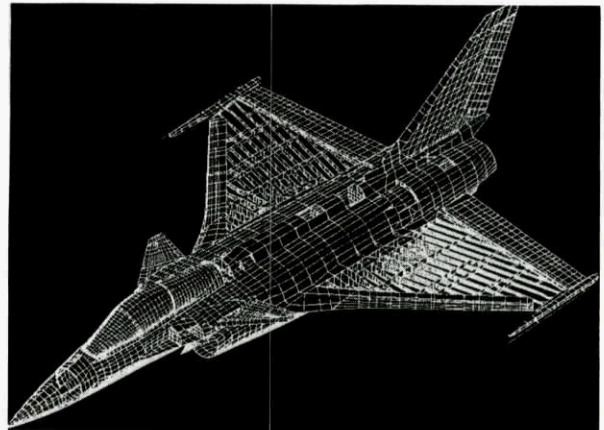
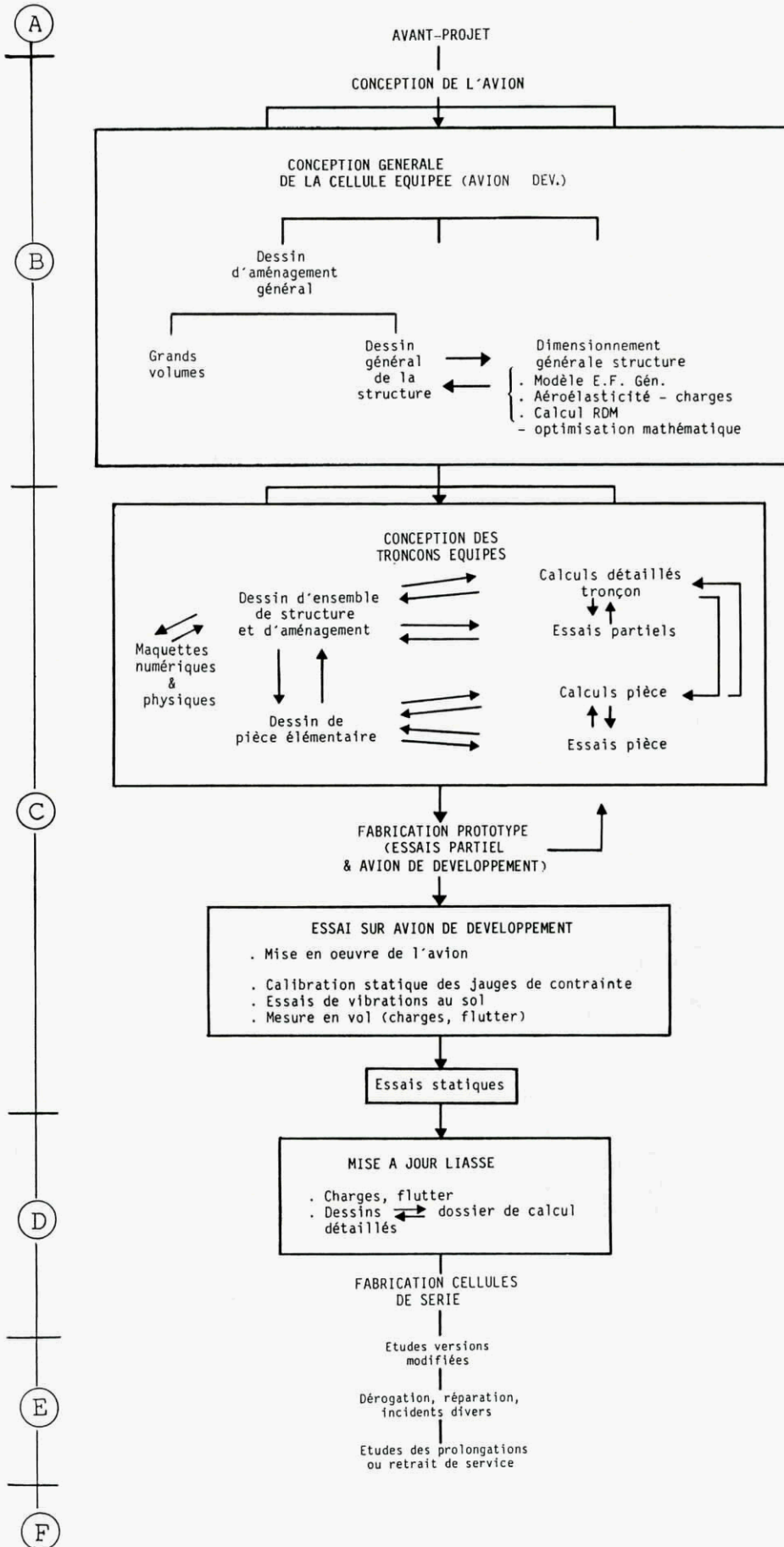

Figure 1

MAILLAGE GENERAL D'UN AVION DE COMBAT

PLANCHE 1



Une optimisation mathématique gère directement l'ensemble de ces analyses, elle fournit l'échantillonnage (épaisseur de peau, section de raidisseur, nombre de plis de chaque direction pour les panneaux composites), le résultat correspondant à la masse minimale tout en satisfaisant simultanément des critères d'aéroélasticité statique, de vitesse de flutter, de résistance des matériaux, etc... (Voir Référence 1).

C'est dans cette phase de conception générale que se réussit un avion. Il en résulte la nécessité d'itérer sur un grand nombre de configurations du dessin général de l'avion et de la structure. Le dimensionnement correspondant à chacune des configurations peut être extrêmement rapide et l'optimisation mathématique garantit l'objectivité des comparaisons.

- CONCEPTION DES TRONCONS EQUIPES

Les dessins de l'aménagement des tronçons et ceux de la structure (dessins d'ensembles et dessins de pièces) se font en complète interaction, ils sont soutenus par les analyses :

- . de la résistance structurale,
- . de l'aptitude à la fabrication,
- . de l'aptitude au soutien logistique (et autres études "RAMS")

Ceci nécessite :

- l'organisation de la concertation entre les divers intervenants (Concurrent Engineering),
- un système de base de donnée informatique commun fédérant toutes les activités ; c'est la "Maquette numérique" construite à partir des modèles CATIA.

Le calcul de la résistance mécanique du tronçon s'appuie sur des modèles raffinés (voir Figure 2) ; ils sont généralement non linéaires (post-flambage, plasticité, contact). Les conditions aux limites de ces calculs locaux sont prises dans le Modèle Général par une technique de "Super élément".

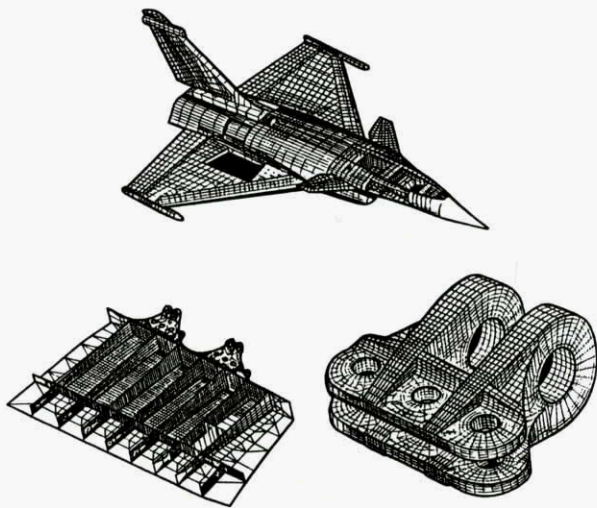

Figure 2 - CALCULS LOCAUX

La pertinence de l'aménagement est vérifiée à la fois avec la maquette numérique et des maquettes physiques.

La conception de détail amène à considérer des situations plus complexes que celles envisagées dans les standards de dessins disponibles initialement. Il en résulte la nécessité de valider ces configurations par des essais partiels. Il faut faire des calculs comparatifs pour valider les conditions de chargement des éprouvettes de ces essais partiels par rapport à celle de l'avion.

Les moyens utilisables aujourd'hui pour la justification de la définition détaillée (calculs et essais) sont dans l'ensemble trop lourds pour permettre plus de 1 ou 2 itérations ; l'outil d'optimisation mathématique de ELFINI n'est pas actuellement opérationnel à ce niveau (Analyses non linéaires, dominante des paramètres de forme).

Il en résulte que la fabrication d'un avion de développement peut être lancée sur une définition qu'on sait pertinemment optimisable.

- ESSAIS SUR LES AVIONS DE DEVELOPPEMENT (Au sol et en vol)

On vérifie là l'ensemble du fonctionnement de l'avion et son aptitude au soutien logistique ; pour valider les modèles structuraux on effectue en plus les 4 types d'essais suivants :

- . Etalonnage statique de l'avion au sol (Réponse de quelques centaines de jauges de contrainte sous l'influence de quelques dizaines de chargements indépendants),
- . Essais de vibration au sol,
- . Identification des charges en vol au travers de la réponse de jauges de contraintes pendant divers types de manoeuvres,
- . Essais de vibration en vol pour la vérification du modèle de flutter.

- CELLULE D'ESSAIS STATIQUES ET DE FATIGUE

C'est elle qui fonde la qualification de la structure pour la résistance mécanique, elle permet de démontrer les marges éventuelles. L'essai statique d'une cellule complète reste nécessaire car on ne peut garantir qu'aucun défaut de "dessin" ne passe le filtre des calculs et des essais partiels.

On limite le risque de rupture prématurée de l'éprouvette en menant les essais statiques progressivement et en recalant constamment les modèles de calcul.

Pour réduire les risques de découverte trop tardive des difficultés, ces essais se font sur la définition de développement. La justification de la définition série est extrapolée ensuite par analyse.

- MISE A JOUR DE LA LIASSE POUR L'AVION DE SERIE

Les modèles généraux (Elastique, Dynamiques, Aéroélastique, Charges) sont recalés à partir :

- . des essais des avions de développement,
- . des modélisations fines des tronçons.

On repasse ensuite sur la définition et la vérification du dimensionnement des tronçons avec des charges locales actualisées.

On reprend en compte :

- . les leçons tirées des vols et de la mise en oeuvre de l'avion de développement,
- . les contraintes liées à l'organisation de la production industrielle qui sont alors mieux analysées,
- . l'ensemble des remords, et des modifications de spécification qui seraient arrivées entre temps.

- OPERATIONS ULTERIEURES

Nous y trouvons :

- les études des versions modifiées de l'avion ;
- les études de dérogations, réparations et de réponses aux incidents divers ;
- les mesures des spectres de charge en service ;
- l'étude des prolongations ou des retraits de services.

La méthode de conception initiale n'est pas indifférente pour ces travaux, qui devraient idéalement se mener en récupérant et en actualisant les modèles mis au point initialement.

- REMARQUES : CHEVAUCHEMENT DES OPERATIONS

Le processus réel est moins séquentiel que nous l'avons schématisé, ainsi :

On n'attend pas que soit figée la définition générale pour lancer :

- l'étude des détails critiques faisant l'objet d'essais partiels ;
- les travaux de préparation de la fabrication démarrent dès qu'une définition préliminaire des pièces est connue ;
- la définition de détails continue à se perfectionner pendant la fabrication et les essais de l'avion de développement.

3 - FACTEURS D'EVOLUTIONS POSSIBLES

Les développements de nos outils ont à satisfaire plusieurs types d'ambitions, quelquefois contradictoires, par exemple :

- réduire la durée des cycles et du coût des opérations,
- tenter la réussite du 1er coup (pas de prototype) quand on n'a pas d'innovation technologique majeure,
- diminuer les risques programmatiques,
- une meilleure optimisation des performances du produit :
- faciliter la prise en compte de nouvelles spécifications qui obligent à innover par rapport aux solutions de dessin standardisé ;
- etc...

Pour satisfaire tout ou partie de ces ambitions nous voyons poindre les techniques suivantes :

- La manipulation d'"Historiques Généralisés" de l'ensemble des données du processus de conception.

L'idée directrice est que l'ensemble des travaux de définition et de justification se matérialisent aujourd'hui par des données entrées par des hommes dans des systèmes informatiques (données des outils de CAO et de calcul, éditions des dossiers de justification, etc..). Pour effectuer les mises à jour nécessitées par les itérations de projet il doit suffire de rejouer ces données qui ont été stockées à la première itération avec leurs motivations, en n'introduisant que les différences avec la définition précédente.

- La définition des paramètres d'optimisation structurale directement au niveau de l'outil de définition CAO, et la possibilité d'effectuer les analyses de sensibilité directement à partir de ces "paramètres CAO".

Aujourd'hui un des freins pour élargir le champ d'application de l'Optimisation Structurale de la version actuelle de ELFINI, et des outils de même type, est que les Variables de Conception sont définies seulement au niveau du maillage éléments finis. Il est maintenant nécessaire de faire l'effort :

- . de définir ces paramètres à la source de la définition (c'est-à-dire le modèle CAO),
- . de développer les outils permettant le calcul des dérivées partielles du maillage E.F. par rapport à ces paramètres, (au-delà l'outil existe voir réf. 1),
- . de définir les nouvelles contraintes "topologiques" de conception,
- . d'adapter l'optimiseur mathématique à ces nouvelles contraintes.

Cet outil permettra aussi de pratiquer l'optimisation avec les analyses non linéaires des dessins de détail qui font pratiquement toujours intervenir des paramètres géométriques.

- Optimisation multidisciplinaire

Disposant d'une CAO manipulant les paramètres de forme on peut envisager de façon réaliste de pratiquer une optimisation mathématique analysant simultanément l'aérodynamique, les performances, les qualités de vol, la structure, et si besoin des aspects de furtivité.

Cette optimisation multidisciplinaire pourrait être menée à partir d'une technique de "condensation" des sous-problèmes d'optimisation de chaque discipline, comme de celle exposée dans la référence 2.

- Conception par "Feature"

Les pièces sont décrites par une suite de traits génériques dits "Features" (Exemples : Tôle, Soyage, Bord tombé, Trou, ...). A ces "Features" sont rattachées des caractéristiques de toutes natures dont les relations avec la géométrie. L'ensemble peut être décrit dans un langage "naturel".

Le modèle géométrique n'est qu'un des résultats de la définition par Feature.

On peut attacher à la description de la pièce elle-même, celle de son processus de fabrication en allant jusqu'à la définition des outillages. Un processus similaire peut s'appliquer au mailage et au calcul de résistance.

Les standards de conception sont introduits dans la programmation des Features, leurs règles peuvent y être manipulées par des techniques d'intelligence artificielle.

En dépit des apparences un certain degré d'innovation peut rester avec la conception par Feature, en concevant des combinaisons originales de "Features" élémentaires.

La conception par Feature n'est pas exclusive des techniques précédentes (historique des données, CAO paramétrée, optimisation) auxquelles sa programmation peut faire appel.

La conception par Feature est potentiellement un facteur de réduction considérable des coûts et des délais de la définition et de la préparation des fabrications des structures. Elle matérialise un véritable "Concurrent Engineering" entre Bureau d'Etude et Bureau de Fabrication. Elle est un facteur de fiabilité par la standardisation qu'elle implique.

- Le perfectionnement des méthodes de calcul

Il joue potentiellement :

- . pour réduire le nombre d'essais,
- . pour pouvoir envisager des dessins s'écartant du Standard sans multiplier les essais partiels, et ainsi faciliter l'innovation en général.

Parmi les domaines où des progrès sont à espérer et qui contraignent actuellement le plus l'organisation de la conception, on peut citer :

- . les calculs élastoplastiques tridimensionnels des assemblages ; ils devront permettre l'évaluation en fatigue et en tolérance au dommage des éléments non standardisés, pour lesquels on ne dispose pas de données expérimentales,
- . le calcul des réponses aux impacts (oiseaux) qui doivent devenir fiables et ainsi mieux supporter la recherche d'un dessin acceptable,
- . les modèles dynamiques moyenne fréquence qui interviennent :
 - pour le système de contrôle du vol quand on veut augmenter sa bande de fréquence et lui donner une fonction de contrôle du flutter,
 - pour l'analyse des problèmes de fatigue aéroacoustique et de vibration des équipements.
- . Les calculs d'aérodynamiques stationnaires et instationnaires qui interviennent dans le calcul des charges et l'analyse du flutter,
- . les techniques de calibration des modèles sur l'ensemble des résultats disponibles d'essais ou les résultats de calcul "locaux" plus sophistiqués.

4 - CONCLUSION

L'arrivée de ces nouveaux outils peut réduire significativement les coûts et les délais d'étude à tous les niveaux ; la standardisation impliquée par ces nouvelles procédures sera un facteur de qualité.

L'optimisation de la solution devrait être bien meilleure grâce à la facilité d'itérer à faible coût dans les études et grâce à l'aide des optimiseurs mathématiques.

Indépendamment des besoins de vérification venant des autres domaines et du Soutien Logistique, le manque de fiabilité des calculs continuerait à nécessiter la grande itération : Définition "Développement" - Définition "Série".

Actuellement sur beaucoup de points cette faiblesse n'est pas due à l'inexistence d'outils appropriés mais à celui du coût de leur emploi systématique. Ce facteur devrait diminuer avec le temps, à la fois par l'augmentation "naturelle" de la puissance informatique disponible, et par la simplification de la mise en oeuvre des calculs, comme celle espérée du "Feature Modeling". Les modèles de calcul standardisés générés par les nouveaux outils diminueront aussi les risques d'erreur humaine à la fois dans les données et les résultats des calculs.

Au démarrage d'un projet d'avion en coopération les partenaires doivent s'être entendus sur la méthode de conception qu'ils veulent pratiquer car c'est elle qui détermine la liste des tâches à effectuer donc à se partager ; elle détermine aussi les interfaces entre ces tâches. Les partenaires doivent aussi disposer des outils, des Standards et du savoir faire correspondant à cette méthode.

Il en résulte que l'étude de la méthode de conception doit être commencée très en amont des programmes :

- pour identifier les méthodes potentielles et émettre la spécification des outils logiciels qu'elles impliquent vers leurs fournisseurs,
- pour développer et tester ces outils,
- pour mettre en place et valider les Standards de Conception informatisés associés aux méthodes (surtout avec le Feature Modeling), aux technologies et aux matériaux proposés.

Pour être efficaces et moins coûteux ces travaux doivent faire l'objet d'une large concertation entre les industriels de l'aéronautique, les fournisseurs de logiciel de CAO et le monde de la Recherche Scientifique.

REFERENCES

- 1 - C. PETIAU
Structural optimization of aircraft
Thin-Walled Structures 11 (1991) 43-64
Elsevier Science Publishers
- 2 - J. SOBIESZCZANSKI - SOBIESKI
Multidisciplinary Design and Optimization
AGARD Lectures Series 186 (1992)

REPORT DOCUMENTATION PAGE											
1. Recipient's Reference	2. Originator's Reference	3. Further Reference	4. Security Classification of Document								
	AGARD-R-794	ISBN 92-835-0729-0	UNCLASSIFIED/ UNLIMITED								
5. Originator	Advisory Group for Aerospace Research and Development North Atlantic Treaty Organization 7 Rue Ancelle, 92200 Neuilly sur Seine, France										
6. Title	INTEGRATED AIRFRAME DESIGN TECHNOLOGY										
7. Presented at	a Workshop held by the AGARD Structures and Materials Panel, in Antalya, Turkey, 19th—20th April 1993.										
8. Author(s)/Editor(s)	Various		9. Date December 1993								
10. Author's/Editor's Address	Various		11. Pages 180								
12. Distribution Statement	There are no restrictions on the distribution of this document. Information about the availability of this and other AGARD unclassified publications is given on the back cover.										
13. Keywords/Descriptors	<table style="width: 100%; border: none;"> <tr> <td style="width: 50%;">Airframes</td> <td style="width: 50%;">Structural analysis</td> </tr> <tr> <td>Design</td> <td>Manufacturing</td> </tr> <tr> <td>Integrated systems</td> <td>Aircraft</td> </tr> <tr> <td>Aerodynamics</td> <td></td> </tr> </table>			Airframes	Structural analysis	Design	Manufacturing	Integrated systems	Aircraft	Aerodynamics	
Airframes	Structural analysis										
Design	Manufacturing										
Integrated systems	Aircraft										
Aerodynamics											
14. Abstract	<p>Integrated airframe design embraces the concept of bringing together all of the aspects of airframe design, including various disciplines such as structures, materials, aerodynamics, controls and manufacturing, from conceptual design all the way through manufacturing. It also includes the sub-disciplines which are involved in each discipline and the interactions these have with one another. Moreover, an IAD process also affects organizational structure of the personnel.</p> <p>In order to provide a broad-based approach to evaluating and identifying future research and development directions required to provide IAD technology, the First Integrated Airframe Design Technology Workshop, sponsored by AGARD, was held in Antalya, Turkey on April 19th-20th 1993. This document summarizes the output of that Workshop.</p>										

<p>AGARD Report 794 Advisory Group for Aerospace Research and Development, NATO INTEGRATED AIRFRAME DESIGN TECHNOLOGY Published December 1993 180 pages</p> <p>Integrated airframe design embraces the concept of bringing together all of the aspects of airframe design, including various disciplines such as structures, materials, aerodynamics, controls and manufacturing, from conceptual design all the way through manufacturing. It also includes the sub-disciplines which are involved in each discipline and the interactions these have with one another. Moreover, an IAD process also affects organizational structure of the personnel.</p> <p>P.T.O.</p>	<p>AGARD Report 794 Advisory Group for Aerospace Research and Development, NATO INTEGRATED AIRFRAME DESIGN TECHNOLOGY Published December 1993 180 pages</p> <p>Integrated airframe design embraces the concept of bringing together all of the aspects of airframe design, including various disciplines such as structures, materials, aerodynamics, controls and manufacturing, from conceptual design all the way through manufacturing. It also includes the sub-disciplines which are involved in each discipline and the interactions these have with one another. Moreover, an IAD process also affects organizational structure of the personnel.</p> <p>P.T.O.</p>	<p>AGARD Report 794 Advisory Group for Aerospace Research and Development, NATO INTEGRATED AIRFRAME DESIGN TECHNOLOGY Published December 1993 180 pages</p> <p>Integrated airframe design embraces the concept of bringing together all of the aspects of airframe design, including various disciplines such as structures, materials, aerodynamics, controls and manufacturing, from conceptual design all the way through manufacturing. It also includes the sub-disciplines which are involved in each discipline and the interactions these have with one another. Moreover, an IAD process also affects organizational structure of the personnel.</p> <p>P.T.O.</p>
<p>AGARD-R-794</p> <p>Airframes Design Integrated systems Aerodynamics Structural analysis Manufacturing Aircraft</p>	<p>AGARD-R-794</p> <p>Airframes Design Integrated systems Aerodynamics Structural analysis Manufacturing Aircraft</p>	<p>AGARD-R-794</p> <p>Airframes Design Integrated systems Aerodynamics Structural analysis Manufacturing Aircraft</p>

<p>ISBN 92-835-0729-0</p> <p>In order to provide a broad-based approach to evaluating and identifying future research and development directions required to provide IAD technology, the First Integrated Airframe Design Technology Workshop, sponsored by AGARD, was held by the Structures and Materials Panel in Antalya, Turkey on April 19th-20th 1993. This document summarizes the output of that Workshop.</p>	<p>ISBN 92-835-0729-0</p> <p>In order to provide a broad-based approach to evaluating and identifying future research and development directions required to provide IAD technology, the First Integrated Airframe Design Technology Workshop, sponsored by AGARD, was held by the Structures and Materials Panel in Antalya, Turkey on April 19th-20th 1993. This document summarizes the output of that Workshop.</p>
<p>ISBN 92-835-0729-0</p> <p>In order to provide a broad-based approach to evaluating and identifying future research and development directions required to provide IAD technology, the First Integrated Airframe Design Technology Workshop, sponsored by AGARD, was held by the Structures and Materials Panel in Antalya, Turkey on April 19th-20th 1993. This document summarizes the output of that Workshop.</p>	<p>ISBN 92-835-0729-0</p> <p>In order to provide a broad-based approach to evaluating and identifying future research and development directions required to provide IAD technology, the First Integrated Airframe Design Technology Workshop, sponsored by AGARD, was held by the Structures and Materials Panel in Antalya, Turkey on April 19th-20th 1993. This document summarizes the output of that Workshop.</p>

AGARD

NATO  OTAN

7 RUE ANCELLE · 92200 NEUILLY-SUR-SEINE
 FRANCE

Télécopie (1)47.38.57.99 · Téléc 610 176

**DIFFUSION DES PUBLICATIONS
 AGARD NON CLASSIFIEES**

Aucun stock de publications n'a existé à AGARD. A partir de 1993, AGARD détiendra un stock limité des publications associées aux cycles de conférences et cours spéciaux ainsi que les AGARDographies et les rapports des groupes de travail, organisés et publiés à partir de 1993 inclus. Les demandes de renseignements doivent être adressées à AGARD par lettre ou par fax à l'adresse indiquée ci-dessus. *Veillez ne pas téléphoner.* La diffusion initiale de toutes les publications de l'AGARD est effectuée auprès des pays membres de l'OTAN par l'intermédiaire des centres de distribution nationaux indiqués ci-dessous. Des exemplaires supplémentaires peuvent parfois être obtenus auprès de ces centres (à l'exception des Etats-Unis). Si vous souhaitez recevoir toutes les publications de l'AGARD, ou simplement celles qui concernent certains Panels, vous pouvez demander à être inclu sur la liste d'envoi de l'un de ces centres. Les publications de l'AGARD sont en vente auprès des agences indiquées ci-dessous, sous forme de photocopie ou de microfiche.

CENTRES DE DIFFUSION NATIONAUX

ALLEMAGNE

Fachinformationszentrum,
 Karlsruhe
 D-7514 Eggenstein-Leopoldshafen 2

BELGIQUE

Coordonnateur AGARD-VSL
 Etat-Major de la Force Aérienne
 Quartier Reine Elisabeth
 Rue d'Evere, 1140 Bruxelles

CANADA

Directeur du Service des Renseignements Scientifiques
 Ministère de la Défense Nationale
 Ottawa, Ontario K1A 0K2

DANEMARK

Danish Defence Research Establishment
 Ryvangs Allé 1
 P.O. Box 2715
 DK-2100 Copenhagen Ø

ESPAGNE

INTA (AGARD Publications)
 Pintor Rosales 34
 28008 Madrid

ETATS-UNIS

National Aeronautics and Space Administration
 Langley Research Center
 M/S 180
 Hampton, Virginia 23665

FRANCE

O.N.E.R.A. (Direction)
 29, Avenue de la Division Leclerc
 92322 Châtillon Cedex

GRECE

Hellenic Air Force
 Air War College
 Scientific and Technical Library
 Dekelia Air Force Base
 Dekelia, Athens TGA 1010

ISLANDE

Director of Aviation
 c/o Flugrad
 Reykjavik

ITALIE

Aeronautica Militare
 Ufficio del Delegato Nazionale all'AGARD
 Aeroporto Pratica di Mare
 00040 Pomezia (Roma)

LUXEMBOURG

Voir Belgique

NORVEGE

Norwegian Defence Research Establishment
 Attn: Biblioteket
 P.O. Box 25
 N-2007 Kjeller

PAYS-BAS

Netherlands Delegation to AGARD
 National Aerospace Laboratory NLR
 P.O. Box 90502
 1006 BM Amsterdam

PORTUGAL

Força Aérea Portuguesa
 Centro de Documentação e Informação
 Alfragide
 2700 Amadora

ROYAUME UNI

Defence Research Information Centre
 Kentigern House
 65 Brown Street
 Glasgow G2 8EX

TURQUIE

Milli Savunma Başkanlığı (MSB)
 ARGE Daire Başkanlığı (ARGE)
 Ankara

Le centre de distribution national des Etats-Unis (NASA/Langley) ne détient PAS de stocks des publications de l'AGARD.
 D'éventuelles demandes de photocopies doivent être formulées directement auprès du NASA Center for Aerospace Information (CASI) à l'adresse suivante:

AGENCES DE VENTE

NASA Center for
 Aerospace Information (CASI)
 800 Elkridge Landing Road
 Linthicum Heights, MD 21090-2934
 United States

ESA/Information Retrieval Service
 European Space Agency
 10, rue Mario Nikis
 75015 Paris
 France

The British Library
 Document Supply Division
 Boston Spa, Wetherby
 West Yorkshire LS23 7BQ
 Royaume Uni

Les demandes de microfiches ou de photocopies de documents AGARD (y compris les demandes faites auprès du CASI) doivent comporter la dénomination AGARD, ainsi que le numéro de série d'AGARD (par exemple AGARD-AG-315). Des informations analogues, telles que le titre et la date de publication sont souhaitables. Veuillez noter qu'il y a lieu de spécifier AGARD-R-nnn et AGARD-AR-nnn lors de la commande des rapports AGARD et des rapports consultatifs AGARD respectivement. Des références bibliographiques complètes ainsi que des résumés des publications AGARD figurent dans les journaux suivants:

Scientific and Technical Aerospace Reports (STAR)
 publié par la NASA Scientific and Technical
 Information Program
 NASA Headquarters (JTT)
 Washington D.C. 20546
 Etats-Unis

Government Reports Announcements and Index (GRA&I)
 publié par le National Technical Information Service
 Springfield
 Virginia 22161
 Etats-Unis

(accessible également en mode interactif dans la base de données bibliographiques en ligne du NTIS, et sur CD-ROM)



AGARD

NATO  OTAN

7 RUE ANCELLE · 92200 NEUILLY-SUR-SEINE

FRANCE

Telefax (1)47.38.57.99 · Telex 610 176

DISTRIBUTION OF UNCLASSIFIED

AGARD PUBLICATIONS

AGARD holds limited quantities of the publications that accompanied Lecture Series and Special Courses held in 1993 or later, and of AGARDographs and Working Group reports published from 1993 onward. For details, write or send a telefax to the address given above. *Please do not telephone.*

AGARD does not hold stocks of publications that accompanied earlier Lecture Series or Courses or of any other publications. Initial distribution of all AGARD publications is made to NATO nations through the National Distribution Centres listed below. Further copies are sometimes available from these centres (except in the United States). If you have a need to receive all AGARD publications, or just those relating to one or more specific AGARD Panels, they may be willing to include you (or your organisation) on their distribution list. AGARD publications may be purchased from the Sales Agencies listed below, in photocopy or microfiche form.

NATIONAL DISTRIBUTION CENTRES

BELGIUM

Coordonnateur AGARD — VSL
 Etat-Major de la Force Aérienne
 Quartier Reine Elisabeth
 Rue d'Evere, 1140 Bruxelles

CANADA

Director Scientific Information Services
 Dept of National Defence
 Ottawa, Ontario K1A 0K2

DENMARK

Danish Defence Research Establishment
 Ryvangs Allé 1
 P.O. Box 2715
 DK-2100 Copenhagen Ø

FRANCE

O.N.E.R.A. (Direction)
 29 Avenue de la Division Leclerc
 92322 Châtillon Cedex

GERMANY

Fachinformationszentrum
 Karlsruhe
 D-7514 Eggenstein-Leopoldshafen 2

GREECE

Hellenic Air Force
 Air War College
 Scientific and Technical Library
 Dekelia Air Force Base
 Dekelia, Athens TGA 1010

ICELAND

Director of Aviation
 c/o Flugrad
 Reykjavik

ITALY

Aeronautica Militare
 Ufficio del Delegato Nazionale all'AGARD
 Aeroporto Pratica di Mare
 00040 Pomezia (Roma)

LUXEMBOURG

See Belgium

NETHERLANDS

Netherlands Delegation to AGARD
 National Aerospace Laboratory, NLR
 P.O. Box 90502
 1006 BM Amsterdam

NORWAY

Norwegian Defence Research Establishment
 Attn: Biblioteket
 P.O. Box 25
 N-2007 Kjeller

PORTUGAL

Força Aérea Portuguesa
 Centro de Documentação e Informação
 Alfragide
 2700 Amadora

SPAIN

INTA (AGARD Publications)
 Pintor Rosales 34
 28008 Madrid

TURKEY

Milli Savunma Başkanlığı (MSB)
 ARGE Daire Başkanlığı (ARGE)
 Ankara

UNITED KINGDOM

Defence Research Information Centre
 Kentigern House
 65 Brown Street
 Glasgow G2 8EX

UNITED STATES

National Aeronautics and Space Administration (NASA)
 Langley Research Center
 M/S 180
 Hampton, Virginia 23665

The United States National Distribution Centre (NASA/Langley) does NOT hold stocks of AGARD publications. Applications for copies should be made direct to the NASA Center for Aerospace Information (CASI) at the address below.

SALES AGENCIES

NASA Center for
 Aerospace Information (CASI)
 800 Elkridge Landing Road
 Linthicum Heights, MD 21090-2934
 United States

ESA/Information Retrieval Service
 European Space Agency
 10, rue Mario Nikis
 75015 Paris
 France

The British Library
 Document Supply Centre
 Boston Spa, Wetherby
 West Yorkshire LS23 7BQ
 United Kingdom

Requests for microfiches or photocopies of AGARD documents (including requests to CASI) should include the word 'AGARD' and the AGARD serial number (for example AGARD-AG-315). Collateral information such as title and publication date is desirable. Note that AGARD Reports and Advisory Reports should be specified as AGARD-R-nnn and AGARD-AR-nnn, respectively. Full bibliographical references and abstracts of AGARD publications are given in the following journals:

Scientific and Technical Aerospace Reports (STAR)

Government Reports Announcements and Index (GRA&I)

Scientific
 publish
 Informa
 NASA
 Washin
 United



320885++P+UL

40 Chigwell Lane, Loughton, Essex IG10 3TZ

UNLIMITED