

P-317654①

THIS DOCUMENT PROVIDED BY THE ABBOTT AEROSPACE
TECHNICAL LIBRARY
ABBOTTAEROSPACE.COM

AGARD-R-790

A

AGARD-R-790

AGARD

ADVISORY GROUP FOR AEROSPACE RESEARCH & DEVELOPMENT
7 RUE ANCELLE 92200 NEUILLY SUR SEINE FRANCE

AGARD REPORT 790

Impact of Materials Defects on Engine Structures Integrity

(L'Impact des Défauts des Matériaux
sur l'Intégrité des Structures des Moteurs)

*Papers presented at the 74th Meeting of the Structures and Materials Panel,
held in Patras, Greece from 27th—28th May 1992.*

Processed / ~~not processed~~ by DIMS
M. J. Mackie signed *9/1/95* date
NOT FOR DESTRUCTION

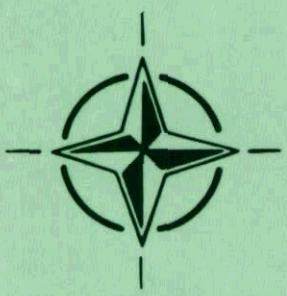

NORTH ATLANTIC TREATY ORGANIZATION

Published April 1993

Distribution and Availability on Back Cover

UNLIMITED

AGARD

ADVISORY GROUP FOR AEROSPACE RESEARCH & DEVELOPMENT

7 RUE ANCELLE 92200 NEUILLY SUR SEINE FRANCE

AGARD REPORT 790

Impact of Materials Defects on Engine Structures Integrity

(L'Impact des Défauts des Matériaux
sur l'Intégrité des Structures des Moteurs)

Papers presented at the 74th Meeting of the Structures and Materials Panel,
held in Patras, Greece from 27th—28th May 1992.



North Atlantic Treaty Organization
Organisation du Traité de l'Atlantique Nord

The Mission of AGARD

According to its Charter, the mission of AGARD is to bring together the leading personalities of the NATO nations in the fields of science and technology relating to aerospace for the following purposes:

- Recommending effective ways for the member nations to use their research and development capabilities for the common benefit of the NATO community;
- Providing scientific and technical advice and assistance to the Military Committee in the field of aerospace research and development (with particular regard to its military application);
- Continuously stimulating advances in the aerospace sciences relevant to strengthening the common defence posture;
- Improving the co-operation among member nations in aerospace research and development;
- Exchange of scientific and technical information;
- Providing assistance to member nations for the purpose of increasing their scientific and technical potential;
- Rendering scientific and technical assistance, as requested, to other NATO bodies and to member nations in connection with research and development problems in the aerospace field.

The highest authority within AGARD is the National Delegates Board consisting of officially appointed senior representatives from each member nation. The mission of AGARD is carried out through the Panels which are composed of experts appointed by the National Delegates, the Consultant and Exchange Programme and the Aerospace Applications Studies Programme. The results of AGARD work are reported to the member nations and the NATO Authorities through the AGARD series of publications of which this is one.

Participation in AGARD activities is by invitation only and is normally limited to citizens of the NATO nations.

The content of this publication has been reproduced directly from material supplied by AGARD or the authors.

Published April 1993

Copyright © AGARD 1993
All Rights Reserved

ISBN 92-835-0711-8



*Printed by Specialised Printing Services Limited
40 Chigwell Lane, Loughton, Essex IG10 3TZ*

Preface

Engine failures due to materials defects are rare, but are still a cause for concern to both manufacturers and lifing authorities. In these circumstances it is recognised that the introduction of higher strength materials, new production routes and improved non-destructive evaluation methods may have significant implications for engine lifing and safety.

Current and future aero-engine design and lifing methodologies have been covered in a recent AGARD-SMP review series on Damage Tolerance for Engine Structures (AGARD-R-768 to -770). This workshop considered the impact of inherent defects on present and future component manufacture and on aircraft engine operation. Materials processing and control aspects were reviewed, placing particular emphasis on nickel and titanium engine disc materials.

Following sessions on Materials Defects — Status and Trends, Product Assurance Enhancement and on Modelling Defect Behaviour, it became clear that the key to future improvements lay in advanced melting techniques and better process control, coupled with a thorough understanding of the role of defects and their significance. Step changes in NDE capability were considered unlikely, and the way forward must be to reduce defects to a level where they can be assumed to be insignificant.

Perhaps the most important point to emerge from the meeting was the variation in participants' interpretation of the word "defect", and the need to find an alternative description for what are essentially microstructural imperfections. To the lawyer "defect" implies "defective", and that a part is not fit for purpose. To the physicist a "defect" may be nothing more than a fault in the material's lattice structure. In materials science "defect" and "flaw" are often used interchangeably to describe normal and wholly expected microstructural occurrences such as grain boundaries, inclusions and second phases.

Given the possible legal implications of the word "defect", the need to find a suitable descriptor for a perfectly normal and anticipated material inhomogeneity was identified. A small group agreed to progress such a definition. It was recommended that, when established, this should be adopted as AGARD standard materials terminology.

On behalf of the Structures and Materials Panel, I would like to thank the authors, attendees and session chairmen whose participation contributed so much to the success of the Workshop.

Colin Gostelow
Chairman, Sub-Committee on the Impact of
Materials Defects on Engine Structures Integrity
Defence Research Agency
Materials & Structures Department
Farnborough, Hants GU14 6TD, UK.

Préface

Les pannes moteur dues à des défauts des matériaux sont rares, mais elles restent un sujet de préoccupation tant pour les avionneurs que pour les services officiels. Par conséquent, il est généralement admis que la mise en oeuvre de nouveaux matériaux plus résistants, de nouvelles routes de fabrication et de méthodes d'évaluation non destructives améliorées peuvent avoir des répercussions importantes pour la sécurité et la gestion du cycle de vie des moteurs.

Les méthodologies actuelles et futures de conception et de gestion du cycle de vie des moteurs d'aéronefs ont été traitées dans une publication récente dans la série AGARD-SMP sur la tolérance aux avaries des structures des moteurs (AGARD-R-768 à 770). Cet atelier a examiné l'impact des défauts inhérents des matériaux sur la fabrication actuelle et future des composants aéronautiques, ainsi que sur l'exploitation des réacteurs. Les participants ont fait le point des aspects traitement et contrôle des matériaux, en mettant l'accent sur les matériaux constitutifs des disques moteur en titane et en nickel.

Lors des différentes sessions sur les Défauts des Matériaux — Situation et Tendances, l'Amélioration de l'Assurance Produit et la Modélisation de l'Evolution des Défauts, il est apparu que la clé des améliorations futures résiderait dans les techniques avancées de fusion et l'amélioration du contrôle en cours de fabrication, ainsi que dans une meilleure compréhension du rôle joué par les défauts, et leur importance. A l'avis des participants il est peu probable que des changements majeurs interviennent dans les techniques de l'examen non-destructif à moyen terme et il faudrait, par conséquent, essayer de minimiser les défauts et les rendre insignifiants.

Les deux points les plus importants qui ressortent de la réunion sont la diversité des interprétations données par les participants au mot "défaut" d'une part, et l'obligation de fournir une autre description de ce que sont, essentiellement, des imperfections microstructurales d'autre part. Pour l'avocat, le mot "défaut" signifie "défectueux", ce qui veut dire mal adapté. Pour le physicien, un "défaut" peut très bien se résumer à une imperfection de la structure réticulaire d'un matériau. En science des matériaux les mots "défaut" et "imperfection" sont souvent employés indifféremment pour décrire des phénomènes microstructuraux tout à fait normaux et prévisibles tels que les limites de granulation, les inclusions et les secondes phases.

Etant donné l'acceptation juridique du terme "défaut", le besoin de trouver un descripteur adapté à une non-homogénéité tout à fait normale et prévisible a été identifié. Il a été convenu que ce travail serait effectué par un groupe restreint. Il a été convenu en outre, qu'une fois cette définition établie, elle serait adoptée en tant que terminologie standard AGARD dans le domaine des matériaux.

Au nom du Panel des Structures et Matériaux, je tiens à remercier l'ensemble des auteurs, participants et présidents de séance dont les contributions ont assuré la réussite de cet atelier.

Colin Gostelow
Président du sous-comité
sur l'impact des défauts des matériaux
sur l'intégrité des structures des moteurs

Defence Research Agency
Materials & Structures Department
Farnborough, Hants GU14 6TD
Royaume-Uni

Structures and Materials Panel

Chairman: Mr Roger Labourdette
Directeur Scientifique des Structures
ONERA
29 ave de la Division Leclerc
92322 Châtillon
France

Deputy Chairman: Dip. Ing. O. Sensburg
Chief Engineer for Structures
MBB Flugzeuge /FE2
Postfach 80 11 60
8000 Munich 80
Germany

SUB-COMMITTEE

Chairman: Mr C.R. Gostelow
R178 Building
DRA Aerospace Division
RAE Farnborough
Hants GU14 6TD
United Kingdom

Members

E. Campo	IT	B.F. Peters	CA
P. Costa	FR	A. Salvetti	IT
H. Goncalo	PO	S.L. Venneri	US
L. Grabowski	UK	J. Waldman	US
A. Looije	NL	W. Wallace	CA
P. Marchese	IT	A.P. Ward	UK
R. Potter	UK	H. Zocher	GE

PANEL EXECUTIVE

Dr Jose M. Carballal, Spain

Mail from Europe:
AGARD—OTAN
Attn: SMP Executive
7, rue Ancelle
92200 Neuilly-sur-Seine
France

Mail from US and Canada:
AGARD—NATO
Attn: SMP Executive
Unit 21551
APO AE 09777

Tel: 33(1)47 38 57 90 & 57 92
Telex: 610176 (France)
Telefax: 33 (1) 47 38 57 99

Contents

	Page
Preface	iii
Préface	iv
Structures and Materials Panel	v
	Reference
SESSION 1	
History and Prognosis of Material Discontinuity Effects on Engine Components Structural Integrity by D.W. Hoepfner	1
SESSION 2a – MATERIALS DEFECTS: STATUS AND TRENDS – TITANIUM	
Paper 2 withdrawn	
Alternative Melting and Refining Routes by A. Mitchell	3
SESSION 2b – MATERIALS DEFECTS: STATUS AND TRENDS – NICKEL	
Process Enhancements of Superalloy Material by R.H. Williams, K.A. Lark, S. Vukelich, D.R. Parille and R.W. Salkeld	4
The Control of Cleanness in Powder Metallurgy Materials for Turbine Disks by G. Raisson	5
SESSION 3 – PRODUCT ASSURANCE ENHANCEMENT	
Maitrise de la Reproductibilité du Procédé de Forgeage par F. Chevet et M. Caralp	6
Paper 7 withdrawn	
Statistical Characterization of Rare Events by C. Annis and S. Vukelich	8
SESSION 4 – MODELLING DEFECT BEHAVIOUR	
Defects and Their Effects on the Integrity of Nickel Based Aeroengine Discs by G.F. Harrison, P.H. Tranter and L. Grabowski	9
Turbine Disks: Lifting against Defects and Materials Development by E. Campo, G. Pasquero, A. Frediani and R. Galatolo	10
Substantiating Powder Metal Life Methodologies for Engines by P.A. Domas	11
Predicting Defect Behaviour by G.W. König and J.W. Bergmann	12

HISTORY AND PROGNOSIS OF MATERIAL DISCONTINUITY EFFECTS ON ENGINE COMPONENTS STRUCTURAL INTEGRITY

David W. Hoepfner, P.E., Ph.D.
Chair and Professor
Mechanical Engineering Department
Director, Quality and Integrity Design Engineering Center
3209 Merrill Engineering Building
University of Utah
Salt Lake City, UT 84112, USA

SUMMARY

Ever since the development of aeroengines, "defects" have been of significant concern to the assurance of structural integrity. Many of these issues have been the focus of recent Structures and Materials Panel (SMP) workshops and conferences. Although engine idealizations of materials being homogeneous, continuous, and "free of defects" are invoked to make the complex issues of load, stress and strain, tractable, they were recognized as early as 1916, and later in the 1930's, as being oversimplistic and potentially in error. The epistemology of the role of discontinuities ("defects") in the design, selection, and lifing of critical aeroengine components is reviewed herein.

Utilization of "defect-free" and "initiation" based fatigue criteria (as well as other time dependent failure modes such as creep, wear, etc.) have led to much success in the aeroengine industry. However, "defects" also have led to numerous engine component failures in military and civilian aeroengines. And, as increasing demands are made on materials used in aeroengines, the role of "defects" will, undoubtedly, become more important and critical.

The history (past and present) and prognosis of these issues is discussed in the paper with a review of on-condition lifing, defect-tolerant and damage-tolerant approaches, including, but not limited to, Engine Structural Integrity Program (ENSIP).

The prognosis will suggest the need for the following:

- Development of increased understanding of the physics of failure processes of aeroengine materials.
- Integration of "defect" considerations in the lifing methodologies from conceptual to detail design. (The new paradigm of lifing.)
- Assurance that knowledge of intrinsic material behavior, including manufacturing specification and control, is a prime consideration in the defect-tolerant approach.
- Non-destructive inspection and evaluation should be one of many tools used to monitor and assure the state of the materials and should be a

consideration in the lifing methodology at the earliest stage.

- Evaluation and integration of the role of extraneous influences, such as fretting, environmental attack, and the like, and how they are factored into the lifing procedure.
- Development of consistent terminology with standardized definitions.

INTRODUCTION

Even though we have made significant progress in increasing reliability of critical components of aeroengines, we have far too many failures in both military and commercial engines. As well, maintenance costs, warranty costs (spares) and liability costs are too high. In addition, designers of aeroengines will undoubtedly always seek to increase performance and efficiency as well as to increase the life of components. At the same time, it is desirable to decrease the need for inspections of components because, in a sense, this adds no value to the product and also causes down time. Designers attempt to expand performance and increase efficiency by increasing combustion and turbine inlet temperatures and increasing operating stresses/strains on the components by either increasing material strength or decreasing component size (weight) or both. As well, it is desirable to minimize risk of unexpected failure while at the same time increasing component life. Current component retirement practices also make it desirable to increase utilization of residual life in components. All of these factors continue to increase the desire to adopt a defect/damage tolerant philosophy of design (including materials selection, characterization, and manufacturing route definition) of critical components of aeroengines. The following sections discuss the past, the present, and looks into the future related to the continued development of gas turbines. There is little doubt that as a community, the gas turbine industry will continue to increase performance, efficiency, and component life while decreasing risk. It will be made clear why this writer believes this cannot be done unless a holistic damage/defect tolerant design philosophy is adopted.

THE PAST

From the very beginning of the development of the gas turbine, there has been an interest in integrity [1-7]. A recent version [8] of some of the excitement at the beginning of the jet age illustrates the highly volatile state of the "human side of enterprise" of development of the jet engine. As critical components were developed in the early days, fatigue and defect tolerance were not prime considerations [1-3, 9]. The "safe-life" approach to fatigue design of aeroengines emerged during the period 1940-1960 [1-3]. This was a natural outgrowth of the evolution of fatigue design in the aircraft industry as well as other industries. The assumptions brought to the design process by the "safe-life" paradigm are very useful. Homogeneity and continuity are extremely restrictive conceptually and when coupled with the assumption of "defect free" become unrealistic. As long as "safety factors" were relatively high and performance and component life demands not too great, these assumptions worked. This is highlighted in E. J. Gumbel's classic on Statistics of Extremes [10] where he points out "Sint ut Sunt Aut Non Sint (accept them as they are or deny their existence)." Although Gumbel was specifically referring to asymptotic distributions, it can well be applied, to use a writer's license, to the study of defects. The safe-life concept has, even though probably not intended (?), essentially ended up denying the existence of "defects."

The following, to a degree, dramatizes the extent to which a decoupling of material behavior (determined by the intrinsic makeup of the material and the way it is manufactured for a specific application in relation to the loads and temperatures) has occurred as discussed in [1-5] and is seen in part in the following quote [11]: "Cyclic crack initiation concepts in fatigue have been used to advantage in engineering design ever since the phenomenon of fatigue was first recognized over a century ago. Crack initiation is considered to be a singular event. Details of how the event evolves are considered to be irrelevant. A unified precise definition of the event has evaded researchers over the years with the result that a broad range of definitions have been used and considerable confusion has resulted."

The conceptual view held by many that "crack initiation" is a singular event (a point function) has made it possible to decouple the physics of materials and inspection (characterization) of the materials to a degree. Halford [11] discusses some of the aspects of this. However, the conceptual view expressed by "initiation" does not appear correct.

The past also has seen efforts dedicated to attempting to develop predictive capability from simplistic assumptions. While this does have some utility to engineers/materials scientists, a great deal of care must be exercised in extrapolating beyond the bounds for which the correlation is known. The use of the Manson-Coffin (universal slopes) equation, Minor's

rule, etc., thus have some utility but it has been recognized by some that their applicability is potentially very restrictive.

The concept that an "initiation life" can be predicted is of interest. However, in the more recent past, the "safe-life" community has been introducing words/phrases to describe life of critical rotating components. A few of these follow:

"LCF" life	"approved" life
"HCF" life	"retirement" life
"initiation" life	"safe" life
"crack-free" life	"on-condition" life
life to "first crack"	"end of" life
"propagation" life	"onset" of cracking
"cleared" life	

These "life" statements have all been gleaned from various gas turbine reports on design/failure analysis, etc. of critical rotating components. They continue to cause some degree of concern as will be discussed.

The Different Paradigm

In the period 1916-1920, Griffith was working on both the design of aeroengines and fracture theory. His contributions to the latter are well known. He provided, in this writer's view, a significant shift to the reality of materials that even today people struggle to avoid. As well, he proposed in his classic paper the basis of a damage/defect tolerant view. He wrote,

"Hence all the material in the immediate neighbourhood will be subject to a tensile stress, and as soon as this exceeds a certain critical value a crack will form." ...

"Further alterations of stress will cause this crack to spread until complete fracture occurs. This theory makes the limiting safe range of stress equal to that which just fails to maintain repeated sliding in the most favorably disposed crystals." ... "The safe limit of alternating stress will usually be less than the apparent stress necessary to initiate yield in a static test, on account of initial stresses, including those due to unequal contraction of the crystals." ...

"Suppose, in accordance with the foregoing theory of fatigue, that one crystal has been fractured, then the general criterion of rupture shows that the crack cannot spread unless the material is subjected to a certain minimum stress, which is greater the smaller the crack." [12]

Thus, from 1920 to now, we have been struggling with this conceptual paradigm shift. This has been discussed in [1-5, 13-25] for engines and general applications. Other papers at this conference also will discuss this.

Part of the dilemma is in how to deal with, and define defect. The dictionary basically defines defect as an imperfection that impairs worth or utility. The ASTM

Compilation of Standard Definitions [26] has numerous definitions of defect. Three of relevance are:

"A condition, corroborated by results of tests, that indicates failure to meet the values listed in the material specification for the property involved." [ASTM D202]

"In nondestructive examination, a discontinuity or group of discontinuities whose indications do not meet specified acceptance criteria." [ASTM E269, E270]

"Any nonconformance of the unit of product to specified requirements; it is classified according to its seriousness." [ASTM D3715]

The two former definitions tend to concentrate on specifications whereas the latter begins to focus on specified requirements.

Polushkin [27] was one of the first to expand the conceptual framework of engineers to consider defects. I was fortunate to be exposed to his writings in the mid-1950's. Polushkin introduced many classifications for defects--notable were those related to shape, size, and dimensions. Foster Stulen was one of the first to take Griffith's concepts and expand them to fatigue [28]. This was an extremely important step in the evolution of our design/manufacturing and material development activity for aeroengines. Additional early recognition of defects in fatigue design was limited [see, e. g. 29] although W. Barrois attempted to shed some light on the state-of-the-art with his classic AGARD work [30]. Defects (imperfections/damage/discontinuities) were formally recognized in 1916 as playing a potentially vital role in establishing integrity. The works cited discuss this in detail, but in the 1950's and 1960's reference works began to emerge [e.g., 31-33] that attempt to raise the level of awareness related to defects. More recent works [34, 35] continue to focus on recognition and classification of damage.

Depending on the technical communities perspective, defects thus may or may not be a vital part of the design process. In 1969-75, a significant effort was formally undertaken, in part with U. S. Air Force encouragement, within the U. S. aviation community. This resulted in the Airframe Structural Integrity Program (ASIP-MIL STD 1530) and is discussed in [36]. Even at this time, the role of defects was of great concern to a few persons in the aeroengine community. The U. S. legal community has played a significant (and important) role in defining a defect. In some respects, the law books that this writer has read are more extensive in their discussion of defect state design than many technical books.

The U. S. legal community defines defects based on user expectations, manufacturers representation, and foreseeability. A test for defect is whether safe performance would exist under foreseeable conditions of use. Thus, defect states must be incorporated into quantified risk-benefit evaluations. (The above is

extracted from [37] as well as other liability and technical books.) Bass goes on to state that:

"Products may be defective in character because they:

- 1. deviate from the condition intended by the manufacturer (manufacturing defect);*
- 2. are unsafe, though perfectly manufactured, because they produce unacceptable consequences;*
- 3. are dangerous because they lack adequate warnings and instructions about risks involved in using products or about minimizing or avoiding harm from such risks;*
- 4. are incapable of meeting their implied or express claims of performance or safety." [37, p. 52]*

Aside from defect/damage considerations being an inherent component of part of Griffith's original formulation, it does not necessarily require that the formation or nucleation phase be specifically dealt with. This is regrettable since it is such an important phase of any component's life [see 1-5, 16, 18, 23]. In recent years the U. S. Air Force, Rolls Royce plc, MTU, SNECMA, NAE (Canada), AGARD-SMP and this writer among others, as well as the legal community, have been encouraging a shift from solely "safe-life" to a damage tolerant view.

THE PRESENT

In recent years, numerous workers have attempted to focus on defect characterization, consideration in design, and elimination. Examples of works in this field are given in [3, 5, 38-43].

The Recent Past - The Present - Transition to the Future

Although Polushkin [27] and others introduced the need to characterize, classify, and evaluate defects, it is only fairly recently that well organized approaches to this have been undertaken. A. Pickard [44] has done this recently. R. Jeal has, on numerous occasions, suggested this approach [R. Jeal in 1, 2, 5].

Table 1 presents a simplified example of classification of "defects" (discontinuities and heterogeneities). Another presentation of a classification was presented in reference [45] as a result of a relatively recent commercial engine fan disc failure [46]. Examples taken from this reference are presented in Tables 2 and 3. Recently, personal communications with T. Swift and J. Costa indicate the U. S. Federal Aviation Administration (FAA) is pursuing some of the issues recommended in [47], particularly with respect to implementation of damage tolerance.

"Defects," thus have been recognized as important for some time. Nonetheless, we have been clinging to the

"safe-life" paradigm as if we were stuck in a metaphor. Table 4 illustrates that we should move to the "new" paradigm as viewed in holistic damage tolerance. The timeline constructed in Figure 1 gives *some* dates that are important in the evolution of the "new" paradigm. Rolls Royce plc and the U. S. Air Force both have been extremely proactive (or is it really retroactive) to the concepts of damage tolerant design. Although I would prefer to state it was due to insight and enlightenment, I don't believe that was the case. At least both have recognized the presence of "defects" and the need to account for them.

TABLE 1
Classification of Potential "Defects" (examples)

"Design" geometric (form/configurational)	
Inherent Material	
vacancies	inclusions
pores/blowholes	constituent particles
dislocation	anomalies
grain boundaries	structure (aligned)
phase boundaries	undesirable grain size, etc.
Manufacturing could lead to above	
Use/Inspection/Maintenance/Storage "fatigue" process "creep" process "wear" process "corrosion" process synergisms	

The CAA regulations [48] introduced the concept of "crack tolerance" in 1980. "A predicted safe cyclic life may be claimed based on testing beyond the point of minor cracking, providing it is shown that the propagation of such cracks will not be such as to lead to failures which could hazard the aeroplane." ENSIP was formally introduced by the U. S. Air Force in 1984 [49]. There are several important issues that ENSIP addressed; viz., the need to characterize non-destructive inspection and evaluation, the need to conduct a crack propagation evaluation based on toughness (limit state design) and crack propagation analysis as well as complete characterization of loads and temperature, and the probability that a "rogue flaw" will escape detection at a given inspection.

The evaluation of "defects" and their effects on integrity has been under rather intense study within the AGARD community and also the TURBISTAN activity. Thus, the recent past has seen both the "safe-life" and damage tolerant methods in use. The transition to the future will continue all of this activity. However, as always, the future represents so much more opportunity for all of us in the technical community.

TABLE 2
Classification of Defects Related to Location in Titanium Discs

Figure 5.K.3

Location of Defect	# of Rotors with Defects 13	# of Incidents of Crack of Rotors 6	# of Incidence of Burst Rotors
Bore		3	7
Web		2	1
Web Hole (or counter-weight hole)	1	0	1
Spacer Arm	1	0	0
Unknown			0

From: [Reference 45] Titanium Rotating Components Review Team Report, FAA, Dec. 1990, p. 5K5

TABLE 3
Partial Review of Titanium Discs Which Have Burst or Cracked in Commercial Application

Table 5.H.1

Titanium Discs Which Burst or Cracked, Due to Metallurgical Defects* in Service, Prior to Sioux City Disc

Percent of approved cyclic life, at which failure was discovered

1.	2.1	B	14.	42.3	C
2.	2.9	C	15.	48.2	C
3.	9.3	B	16.	48.9	C
4.	10.9	B	17.	49.4	B
5.	12.3	B	18.	61.9	C
6.	13.0	B	19.	64.9	C
7.	13.4	B	20.	71.0	B
8.	21.0	B	21.	72.3	C
9.	31.9	B	22.	79.2	C
10.	32.0	B	23.	80.3	B
11.	33.9	C	24.	86.1	B
12.	34.0	B			(Sioux City Disc)
13.	38.2	B	25.	88.4	C

B = Burst 41.9 = mean % life at discovery

C = Cracked 38.2 = median % life at discovery

*These metallurgical defects include: Types I & II, other segregation types, voids, and porosity.

from: [Reference 45] Titanium Rotating Components Review Team Report, FAA, Dec. 1990, p. 5H24.

FUTURE

It is extremely difficult to look at the future but I am challenged by this opportunity. It appears that the future will bring an increased awareness of the role of discontinuities and heterogeneities on integrity. These "defects" must be recognized in the entire design process (closed loop) and it must be recognized that the "defects" may:

1. be present as inherent cracks and propagate if a critical stress/energy is attained;
2. be benign;
3. be non-crack-like and agglomerate to form/nucleate crack(s) that may propagate; and
4. the propagation, given it occurs, may be influenced by micro/macro structure.

5. develop improved experimental techniques to develop physically based models of crack nucleation and structurally dependent crack propagation;
6. treat "safe-life" as a phase/subdivision of a holistic damage/defect tolerant philosophy;
7. purge the initiation conceptual view from design of critical rotating components;
8. improve the education of engineers and materials personnel to the damage tolerant view.

Improved modelling of the crack nucleation and propagation process is one of the essentials to implement holistic damage tolerance. As well, improved NDI/NDE practices and understanding of "defect" development in manufacturing is required. Other speakers in this workshop will discuss this further.

My laboratories at the University of Utah have been pursuing modelling and data base development for many years. We have developed numerous fatigue machines that attach to scanning electron microscopes for in situ evaluation of study of crack detection and structurally dependent growth. Numerous doctorate theses and post-doctoral activities have emerged from this work. Recently, we have detected surface cracks of the order of 5-10µ in both wasp alloy, IMI 834, and one ceramic. We have studied crack growth from inherent discontinuities in these and other materials for many years. New experimental techniques have been, and are being, developed that I believe will aid us in understanding crack nucleation/formation and growth. It appears that different analytical procedures will be needed to realistically treat structurally dependent crack growth in the future.

The future looks very promising related to further improvements of the integrity of critical engine components.

ACKNOWLEDGEMENTS

Thank you for once again inviting me to participate in an AGARD-SMP activity. I wish to acknowledge the continuing support of my wife, Sue, and daughters as I pursue all of these endeavors connected with "defects." Since 1973, I have been privileged to count among my friends and close colleagues Robert Jeal. I remain grateful to Bob for his continuing discussions at present and the past. Rolls Royce plc has been extremely supportive of my ideas since 1973. They continue to support my research at the University of Utah. I am particularly indebted to Dr. Leon Grabowski for many stimulating discussions over the recent years. The Boeing Commercial Airplane Company, Garrett Auxiliary Power Division, and the FAA all have been supportive of my recent pursuits, and I am grateful. The University of Utah has been gracious in providing

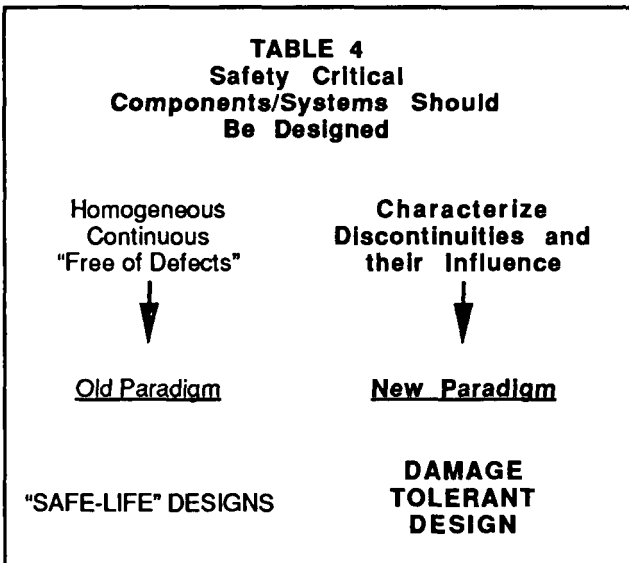

New tools, both analytical and experimental will have to be developed to deal with some phases of component life. The other papers in this workshop shed some light on this.

Additional future needs are as follows:

1. improved inspection techniques
 - a. in plant (suppliers),
 - b. at the depot level,
 - c. at repair stations;
2. develop vastly improved abilities to understand "physics" of materials behavior;
3. formulate new models to correlate/predict behavior;
4. expand our data bases;

me time, facilities, and travel funds to attend this workshop. I am grateful to Ms. Paula Jorgensen for assisting in the manuscript preparation, the slides preparation, and aiding in all other arrangements for attending. She was ably assisted by Ms. Shauna Forbes. I thank them for their extensive assistance. The many students who have worked with me over the many years have been a continuous inspiration to me. I thank them for allowing me to assist them in their learning endeavors.

4. Damage Tolerance for Engine Structures. Non-Destructive Evaluation, AGARD Report No. 768, NATO, AGARD, SMP, 7 Rue Ancelle, 9200 Neuilly sur Seine, France, May 1988.
5. Damage Tolerance for Engine Structures. 2. Defects and Quantitative Materials Behaviour, AGARD-R-769, NATO-AGARD, 1988.

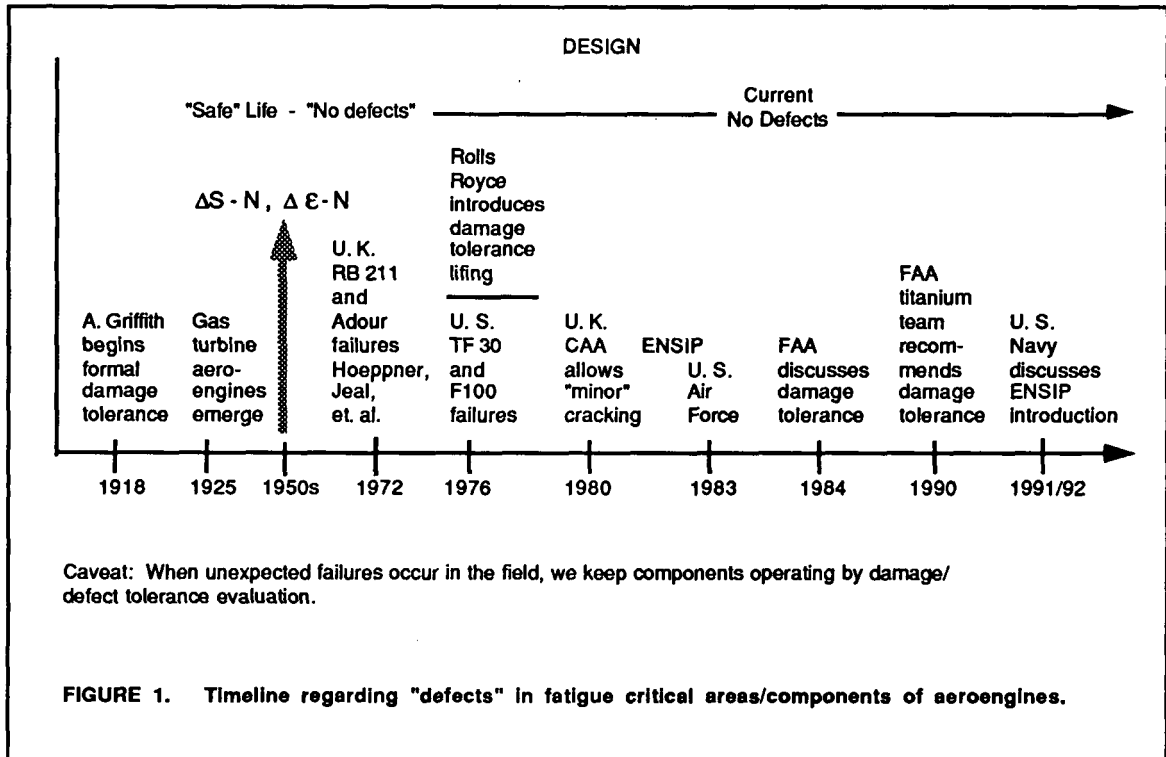

REFERENCES

1. Maintenance in Service of High Temperature Parts, AGARD-CP-317, NATO, AGARD, SMP, 7 Rue Ancelle, 92200 Neuilly sur Seine, France, January 1982.
2. Engine Cyclic Durability by Analysis and Testing, AGARD-CP-368, NATO, AGARD, SMP, 7 Rue Ancelle, 92200 Neuilly sur Sein, France, September 1984.
3. Damage Tolerance Concepts for Critical Engine Components, AGARD-CP-393, NATO AGARD, SMP, 7 Rue Ancelle, 92200 Neuilly sur Seine, France, October, 1985.
4. Whittle, F., "The Early History of the Whittle Jet Propulsion Gas Turbine," The First James Clayton Lecture, I. Mech. E., 1945, vol. 152, pp. 419-435.
5. Constant, H., "The Early History of the Axial Type of Gas Turbine Engine," I. Mech. E., Proceedings, vol. 153, 1946, pp. 411-440.
6. Golly, J. (in association with Sir F. Whittle), Whittle the True Story, Smithsonian Institute Press, Washington, D.C., 1987.
7. Gadd, E.R., "Fatigue in Aero-Engines," Proceedings of the International Conference on Fatigue of Metals, I. Mech. E., London, England, 1956, pp. 658-671.
8. Gumbel, E.J., Statistics of Extremes, Columbia University Press, N.Y., N.Y., 1958, pp. 156.

11. Halford, G., *Low-Cycle Thermal Fatigue*, NASA TM 87225, February, 1986, p. 11; Halford G., *Low-Cycle Thermal Fatigue*, Chapter 6, Thermal Stresses II, Elsevier Science, 1987, pp. 330-428.
12. Griffith, A.A., "The Phenomena of Rupture and Flow in Solids," *Philosophical Transactions of the Royal Society*, vol. 221 A (1920), p. 163-198.
13. Hoepfner, D.W., Discussions related to Damage Tolerance Applied to Aeroengines, Lockheed California Co., presented at Rolls Royce, Derby, England 1972/1973.
14. Hoepfner, D.W., Krupp, W.E., "Prediction of Component Life by Application of Fatigue Crack Growth Knowledge," *Engineering Fracture Mechanics*, vol. 6, 1974, pp. 47-70.
15. Hoepfner, D.W., "A Fractographic Analysis of Flaw Growth in a High Strength Titanium Alloy," *Metallography*, (II), pp. 129-154, 1978.
16. Hoepfner, D.W., et al, *Aircraft Structural Fatigue*, course notes for course of the same title delivered at University of Toronto and University of Utah. Prepared 1979 for U.S. Federal Aviation Administration, Revised 1985-1991.
17. Hoepfner, D.W., "Estimation of Component Life by Application of Fatigue Crack Growth Threshold Knowledge," *Fatigue, Creep, and Pressure Vessels for Elevated Temperature Service*, MPC-17, ASME, N.Y., N.Y., 1981, pp. 1-84.
18. Hoepfner, D.W., "Application of Damage Tolerance Concepts to Short Cracks in Safety Critical Components," ICAF No. 12, paper No. 2-1, Toulouse, France, May 25-27, 1983.
19. Hoepfner, D.W., "Damage Tolerance Concepts Applied to Discs in Aeroengines," Presentation at FAA meeting held in Burlington, MA., March 12-13, 1984.
20. Hoepfner, D.W., "Parameters That Input to Application of Damage Tolerance Concepts to Critical Engine Components," paper 4, op. cit. 3., 1985.
21. Hoepfner, D.W., "Future Technology Requirements (Related to Defects and Quantitative Material Behavior to Aid in Implementation of Damage Tolerance for Design of Engine Structures," paper 7 op. cit. 5., 1988.
22. Hoepfner, D.W., "Fatigue and Damage Tolerance Concepts Applied to Critical Aircraft Components," Distinguished AIAA Lecture presented at various U.S./Canadian locations (1987/88).
23. Freudenthal, A.M., "Fatigue and Fracture Mechanics," *Engineering Fracture Mechanics*, (1973) Vol. 5 pp. 403-414.
24. Jeal, R.H., "Defects and Their Effect on the Behaviour of Gas Turbine Discs," *Maintenance in Service of High Temperature Parts*, op. cit. 1 (1982) pp. 6-1 to 6-15.
25. Harris, J.A., et al., "Engine Component Retirement for Cause," *Maintenance in Service of High Temperature Parts*, op. cit. 1, (1982) pp. 5-1 to 5-9.
26. Compilation of ASTM Standard Definitions, ASTM, Philadelphia, PA., Sixth Ed., 1986, p. 208.
27. Polushkin, E.P., *Defects and Failures in Metals*, Elsevier Publishing Co., N.Y., N.Y., 1956.
28. Stulen, F.B., Cummings, H.N., Schulte, W.C., "Relation of Inclusions to the Fatigue Properties of High-Strength Steels," op. cit. 9, pp. 439-444.
29. Waisman, J.L., "Factors Affecting Fatigue Strength," *Metal Fatigue*, edited by Sines, G., Waisman, J.L., McGraw-Hill, New York, N.Y., 1959, pp. 29-35.
30. Barrois, W.G., *Manual on Fatigue of Structures-Fundamental and Physical Aspects*, AGARD-MAN-8-70, NATO-AGARD, London, 1970.
31. Parker, E.R., Washburn, J., "Effects of Impurities and Imperfections on Mechanical Properties," *Impurities and Imperfections*, ASM, Cleveland, Ohio, 1955, pp. 145-161.
32. *Vacancies and Other Point Defects in Metals and Alloys*, Institute of Metals, Monograph No. 23, London, England, 1958.
33. Van Bueren, H.G., *Imperfections in Crystals*, North-Holland Publishing Company, Amsterdam, 1960.
34. Engel, L., Klingele, H., *An Atlas of Metal Damage*, Carl Hansen Verlag, Munich, Germany, 1981.
35. "Fatigue Failures," *Metals Handbook, 9th Edition, Vol. II. Failure Analysis and Prevention*, ASM, Metals Park, Ohio, 1986, p. 102.
36. *Fracture Prevention and Control*, edited by David W. Hoepfner, ASM, Metals Park, Ohio, 1974.
37. Bass, L., *Products Liability-Design and Manufacturing Defects*, Shephard's/McGraw-Hill,

Inc., P.O. Box 1235, Colorado Springs, Co.,
80901, 1986, Chapter 4.

38. Blackburn, M.J., Law, C.C., Influence of Subsurface Defects on Fatigue Properties of Titanium Alloys, AFML-TR-77-112, July 1977.
39. Forging and Properties of Aerospace Materials. The Metals Society, London, England, 1978.
40. Betz, W., Track, W., "Living with Defects in PM-Materials," Powder Metallurgy Superalloys, MPR Publishing, Shrewbury, England, 1980, paper 19.
41. Lowenstein, P., "Superclean Superalloy Powders by the Rotating Electrode Process," 1980, op. cit. 40, paper 7.
42. Donachie, M., "Relationship of Properties to Microstructure in Superalloys," Superalloys Source Book, edited by Donachie, M.J., ASM, Metals Park, Ohio, 1984.
43. Holdsworth, S.R., Hoffelner, W., "Fracture Mechanics and Crack Growth in Fatigue," High Temperature Alloys for Gas Turbines-1982, D. Reidel Publishing Co., Boston, MA, 1982, pp. 345-368.
44. Pickard A.C., "Review of Component Defects, Their Relationship to Manufacturing Process and Their Effect on Materials Behaviour (for Critical Rotating Parts)," op. cit. 5, Paper 3.
45. Costa, J., Guyotte, R., Swift, T., Gonzalez, R., Solvano, D., Koenig, R.J., Titanium Rotating Components Review Team Report, FAA, Aircraft Certification Office, Engine and Propeller Directorate, Dec. 1990.
46. Aircraft Accident Report, PB 90-910406, NTSB/AAR-90/06, [Re: UA Flight 232] Accident July 19, 1989, Report Date Nov., 1990.
47. Personal communication, T. Swift/J. Costa (Long Beach, California) with D.W. Hoepfner, April 21, 1992.
48. CAA Requirements for Turbine Engines for Aeroplanes, Chapter C 3-2, Appendix 2.4.2, 1980.
49. ENSIP, MIL STD. 1783, U.S. Air Force 1984.

ALTERNATE MELTING AND REFINING ROUTES

by

Alec Mitchell

Dept of Metals and Materials Engineering
University of British Columbia
309-6350 Stores Road
Vancouver B.C.
Canada V6T 1Z4

Abstract

Although most research and development effort in turbine alloys has been in the past directed towards the understanding and improvement of basic properties, it is a telling comment on the results that at present we can only manufacture the components with a reliability which, in the example case of a high pressure turbine disk, leads to a service life of less than one-fifth of the theoretical life of the alloy component. The purpose of this presentation is to examine the reasons for this situation and to indicate ways in which we can improve on it. We conclude that the techniques of melting, refining and casting which are now being developed have the potential to make a large change in the in-service life of turbine components without any significant change in the state of alloy development.

INTRODUCTION

The alloys which we presently use in engine components consist of steels, superalloys and titanium alloys. The methods of production of these alloys differ considerably, but there is a common theme in that the limiting factor in the service use is that of allowing for the occurrence of random defects which are not reliably eliminated by production or in-service inspection. (In this context "reliably" implies a detection rate which is sufficiently high that the designer can neglect the occurrence rate in assigning a fracture or fatigue limit to the component, and instead use the intrinsic properties of the alloy to establish for example, LCF life). In the case of the high strength steels used in fasteners and shafting (e.g. Maraging 250), the limits are set by the inclusion content of the alloy in regard to clustered inclusions of a size greater than a critical value. For bearing steels (e.g. M50), the limit is set by the interaction of clustered oxides with the alloy's carbide structure in giving a compound defect of a size greater than the critical value. The superalloys occasionally contain the same type of problem as do the bearing steels, but more commonly the limit is reached by defects of melting and solidification typified by the "LEA" defect.

The titanium alloys contain some solidification defects such as alpha-II or periodic banding ("tree-rings"), but by far the most important defect is that of alpha-I or "hard-alpha". This latter defect has been quoted¹ as the single most important materials problem facing the engine builder, and has been responsible for a number of in-service failures leading to aircraft crashes in both the civil and military applications. Although all of these alloys and defects may seem to represent a very varied selection of problems, the theme of the random defect introduced by a lack of process control during melting is common to them all. It is this theme which we must address in specifying any improvements to the process sequence.

We may generally group the defects into two types; those which represent the failure of the process to remove a component of the system, and those in which the process has introduced the defect into an otherwise acceptable structure.

The first class would contain such problems as inclusion clusters or hard-alpha, whilst the second would include white spots and segregation defects. These two types will be considered separately in order to draw the conclusions necessary to define the need for alternative processes.

INCLUSION DEFECTS

Inclusions are conventionally grouped into two classes; indigenous and exogenous. The former are the result of either oxygen or nitrogen in solution in the liquid alloy at high temperature combining with an alloy component during cooling to precipitate a second phase in the system. Examples might be the precipitation of alumina during the freezing of an aluminium-deoxidised steel or the precipitation of TiN during the freezing of a superalloy containing trace quantities of nitrogen. The governing thermochemical equations which describe these processes are quite well established for steels but are less well so for the superalloys. We may compute the precipitation behaviour of, for example alumina or aluminates in a high strength or stainless steel with a reasonable degree of accuracy, but can only do so as an approximation for the same systems in the superalloys due to the lack of basic data. This type of precipitation reaction does not take place in the range of titanium alloys used in our present engines or airframes since the bulk composition with respect to both oxygen and nitrogen is well below the appropriate solubility limit.

The problem to be considered in regard to this type of defect is not that of the content of individual inclusions, since in the processes we presently use (VIM, VAR, ESR), the average inclusion size can be maintained well below that of the critical defect size. The inclusions become a mechanical problem only when they are clustered or agglomerated to an extent that during operation the stress fields of the individual inclusions are able to overlap, thus turning a collection of separated inclusions into a "super inclusion" whose effective size is larger than the critical defect. Such agglomeration can take place either in the liquid during cooling, or in the interdendritic liquid during freezing. In both cases the agglomerations of primary precipitates can rarely be altered by solid-state processing such as forging, extrusion or

homogenisation although all of these processes have a strong influence on other aspects of the alloy structure.

The solution applied in process sequences up to the present has been to progressively reduce the oxygen and nitrogen contents allowed by specification in the alloys so as to decrease both the size and frequency of occurrence of the agglomerations. An example could be taken from the premium-quality, turbine disk IN718 specifications operating in the USA where the allowable nitrogen content has been reduced from 120ppm (c.1965) to the present value of 80ppm, with a present average actual nitrogen from the qualified producers of around 60ppm. Even this value is, however, well in excess of the saturation solubility of TiN at the liquidus temperature of IN718 (38ppm), and we may still expect to find a significant fraction of agglomerated nitride inclusions, as is observed in practice². In contrast, the specification for cast, premium quality IN718 has been 25ppm for many years. This limitation probably arose due to the effect of TiN in obstructing the interdendritic fluid flow necessary to prevent microporosity in thin-wall castings, resulting in the experience that high-nitrogen alloys contained unacceptable microporosity. Collections of agglomerated TiN particles are not found in the low nitrogen alloys².

The situation in the field of oxide inclusions is similar in principle, but quite different in practice because the relevant solubility limits are much lower in this case than in that of the nitrides. In an example case of Rene 95, the alumina saturation solubility limit at the liquidus temperature occurs at 0.1ppm oxygen, which is well below the level found in the product of any present process.

The problem of exogenous inclusions is more difficultly to quantify. In alloys which are conventionally melted in VIM using refractory-lined crucibles, (all steels and superalloys in both the cast and wrought forms) the principal sources of exogenous inclusions are refractory particles from the crucible lining and entrapped process slag or dross. Since most of this material is subsequently melted by the VAR or ESR process, one might expect that the exogenous inclusions would be removed. However, whilst they are removed with a high level of reliability in a properly-conducted ESR process, it is very common to find the VIM inclusions essentially unchanged by the VAR process. This feature is to be expected since the VAR process contains inherent instabilities in the arc movement which can easily result in the transfer from electrode to ingot of undissociated inclusions or in the entrapment of floating "islands" of agglomerated inclusions. It is axiomatic in the industry that the quality of the VAR ingot depends almost entirely on the quality of the VIM electrode.

In the ESR process operated in the normal range of melting rates, the exogenous type of inclusion is entirely removed from the melting electrode by solution in the process slag. Only when the process is conducted at very low melting rates do we begin to see electrode inclusions in the ingot, or trapped slag from the ESR process itself. Unfortunately, this is precisely the condition which we are forced to use in manufacturing most of the rotating-part alloys, since there are severe restrictions on the maximum permitted melting rate imposed by the need to control ingot segregation. In making alloys which segregate readily it is not possible to utilise the full capability of the ESR process for removing inclusions.

The inclusion problem in titanium alloys is entirely associated with the presence of defect-forming material in the feed supplied to the melting processes. The two commonest types of exogenous inclusion are "high-density" (HDI) and "low-density" (LDI). The former consists of pieces of tool-

bit chips (usually cobalt-bonded tungsten carbide) carried through from machining operations, undissolved particles of heavy element alloy additions (e.g. Nb, Mo or Ta), or particles of tungsten which have been included in scrap titanium through welding operations involving tungsten electrodes. The removal mechanism of these particles in the VAR process has been well documented³ and it has been established that even in multiple VAR they pass through the process essentially without change. Essentially the method of control of this type of defect lies in the preparation of the raw material before VAR and in the rigorous observance of agreed procedures which prohibit the use of refractory metals in the titanium production stream. Using these techniques has made the occurrence of this type of problem a very rare event in engine-quality titanium alloys, but since it relies on monitoring manual operations in several separate installations comprising the production scheme, all of which are also engaged in non-aerospace titanium applications, there is an ever-present danger that it will appear.

The LDI defect has been extensively studied³ and has many possible points of origin in the process. The commonest sources are those of contaminated scrap recycled into the VAR electrode, contaminated primary titanium sponge and welding processes used in the construction of the VAR electrode. The LDI particle consists of titanium contaminated with a high level of either or both oxygen and nitrogen. These elements raise the melting point of the alloy quite strongly so that the contaminated volume will not melt in the VAR temperature regime, but instead the particle can only be dissolved in the bulk alloy by a diffusion process during VAR. The particles have a bulk density which is quite close to that of the liquid alloy and so are not concentrated or removed by any buoyancy forces. The solution rate of the LDI is sufficiently slow⁴ that they will survive triple VAR melting to form an alpha-stabilised zone in the final alloy component. The alpha is also strongly hardened by the interstitial O and N, so that it is an ideal crack-starter in LCF. If it intersects a machined surface, or if there is an associated crack at the manufacturing stage it is possible to detect it and reject the part. However, if it is only slightly sub-surface or has only a small associated crack, it can be non-detectable by the methods presently used for either OEM inspection or periodic in-service inspection, but still provide a site for LCF failure. Experience has shown that even triple VAR will not guarantee the absence of this defect in engine parts and recent specification changes have recommended cold-hearth processing as the most appropriate method for removing the defect. As yet, this change is not mandatory for all engine parts but will probably be so in the near future.

REMOVAL OF INCLUSION DEFECTS THROUGH REFINING PRACTICES

Steels and superalloys

There are number of choices in the potential for the removal of inclusions in our present process routes which have probably as yet not been fully put into practice. The most obvious one lies in the choice of raw materials so as to minimise the load of oxygen and nitrogen on the melting and refining system. This has been the route chosen by the superalloy casting industry for many years and could probably be extended into other fields with a moderate positive impact on inclusion contents, but is deemed by the industry to be economically non-viable. It is practiced to some degree at the moment in that wrought superalloy specifications usually limit the permitted amount of reverted alloy which can be used in

the charge mix. However, in all of the alloys, no matter what the raw material source it is necessary to allow for the presence of some level of inclusion material at the end of the VIM refining period. This is particularly important for rotating grades of superalloy in which the required low sulphur levels (<2-3ppm S) can only be attained by using a desulphurising slag in the VIM. The VIM process is then followed by a combination of tundish and filtering intended to remove the solid/liquid inclusion and slag content from the metal before casting.

The function of this combination is as follows. The tundish is designed to control the pouring flow so the turbulence is eliminated and the large particles of slag, dross and inclusions can float to the surface and be separated. The liquid is also controlled in temperature to a minimum level of superheat (<30°C) so that inclusions will precipitate to the maximum extent. After this has been done, the metal passes through a porous ceramic plug or tile which collects the inclusions by a surface adhesion mechanism. Alumina and TiN adhere to the ceramic surface (which is alumina or zirconia) so that the filter acts as a "sponge" rather than strictly as a filter since the individual particles are much smaller than the filter pore-size. This set of techniques has been used to great advantage in the casting industry, reducing zyglon rejections considerably over the past few years. However, it is very difficult to carry out on the scale demanded by the forging industry and as yet it has little practical application. The difficulty is connected with the required size of tundish which becomes too large a heat-loss at this scale. The corollary of this finding is that we must use a tundish with additional heating, but the necessary design changes to accomplish this are evidently too costly or impractical for the VIM furnaces in use at present.

As an interim measure to reduce inclusion load we have used the properties of the ESR process, carried out at its optimum rate. Several studies have shown⁵ that ESR alloys are significantly cleaner than either VAR or VIM, and so the route VIM/ESR is capable of making quite clean alloys. However, to ensure this improvement, we must use ESR at a rate which gives unacceptable segregation in the ingot. The ESR ingot is normally also free from the macroporosity and thermal cracks which typify VIM cast electrodes and so is an ideal electrode for the VAR process, where we can then use the VAR capability for melting at the low rates necessary for solidification control. The sequence VIM/ESR/VAR has become known as "triple melt" and is now the industry standard for rotating parts in many turbine applications in both aerospace and power generating applications. Although the sequence was originally introduced to alleviate segregation problems (see below), it has also proved to be advantageous in the application outlined for the reduction of inclusion content.

In any of the above alternatives, however, we do not have the quantum reduction of maximum inclusion size that would be required for any significant design changes⁶. It appears that there are two complementary possibilities for accomplishing this aim; to extend the inclusion removal technique by using cold hearth refining, and to extend the chemistry changes into the region where inclusion precipitation will not take place. The object of using hearth refining is to allow the full flotation of exogenous particles, which implies the use of a system containing the minimum of turbulence and a highly predictable regime of both temperature and fluid flow. At present, the only practical system fitting these requirements is the EB hearth furnace operated in a mode where the heating is carried out with multiple small EB guns working with a programmed PLC. It

has been demonstrated both in theory and practice⁷ that such a system has the control and beam speed capability to maintain the required stable fluid flow and also to use the Marangoni flows in the beam impingement region to provide a stable barrier for preventing the floating inclusions being entrained in the metal flow. This type of furnace has just begun its debut in industrial application for the manufacture of superalloys destined for airfoil castings, and can be relied upon to produce the alloys at N and O contents which are at least at the solubility limit at the temperature operating in the final region of the metal flow in the hearth, as well as ensuring freedom from the exogenous inclusions which have been a major cause of both in-service failures and production rejections for many years. It is to be anticipated that the added cost of the EBCHM step will be compensated for by the lowered cost of these rejects.

The EBCHM technique does not, however, attack the problem of the indigenous inclusions without some added process requirements. The ideal alloy composition to avoid this problem, as indicated above, would be one in which the O, S and N contents were all lower than those which would precipitate inclusions on freezing. In the steels and superalloys of interest, this situation is reasonably easy to attain in the cases of S and N with processing by VIM + desulphurisation and/or ESR using argon cover, with the use also of high quality raw materials, thus providing to the final process step a feed alloy which only requires suitable lowering of the oxygen content and solidification control. The thermochemical data required for the full definition of this process is available only for the stainless steels, but fortunately can be extrapolated fairly reliably into the maraging compositions and extended approximately into the superalloys. It has been shown⁸ that the computation of the required composition must take into account the segregation which occurs on freezing, which in turn is linked to the solidification conditions. If we assume that the solidification process which we chose will be slow enough to establish equilibrium segregation in the interdendritic liquid during freezing, we may compute the composition profile in this liquid as the freezing process progresses, with respect to the elements which form the oxide inclusions -- in almost all cases aluminium and oxygen. Such a composition profile is shown in Fig 1, for the case of Maraging 250, and provides the compositions which would prevent the formation of any oxide inclusions in this alloy under the freezing conditions normally present in the freezing of a large EB ingot. Experimental work on the 300-series stainless steels has confirmed the correctness of this hypothesis, but also raised a secondary problem which would cause difficulties in the industrial realisation of this idea. The obtaining of the very low oxygen content required is achieved by the decomposition of oxides (using the reaction with carbon in the feed alloy) under the temperature/time/pressure conditions in the EB furnace, which, as shown by Fig 2, will work satisfactorily for all inclusion compositions except CaO and some calcium aluminates. Since the required low sulphur content is usually obtained by some system of reacting the alloy with CaO in VIM, ESR, or a secondary steelmaking process such as AOD, making the feed alloy with a low sulphur content and also without included CaO-based inclusions or Ca in alloy solution presents a significant problem. Nonetheless, by a suitable sequence of slag treatments it can probably be successfully achieved in all of the alloys of interest. The 300-series stainless steels used in the demonstration of this principle⁸ also illustrate another aspect of the process sequence which must be taken into account, namely the strong evaporation

which takes place in the EB system. The EBCHM furnace is designed to maximise the contact between the liquid metal and the ambient vacuum so as to use the carbon reduction reactions to the maximum extent; a system design which necessarily also maximises the evaporation of any volatile alloy elements. In the steels and superalloys, this reaction applies effectively to four alloy elements, Cr, Mg, Mn, and Cu. The Cr evaporation is relatively slow and can be easily controlled by the addition of a small excess to the feed alloy. The evaporation of the other three elements is rapid and in the case of Mg sufficiently so that it is doubtful that the EB system could ever be designed to retain the presently accepted contents in the superalloys. In the 300-series stainless steels extensive Mn evaporation was found and could not be controlled at the same time as obtaining the required C/O reaction. Examples of systems in which this aspect would be a problem are Mn in 300M and Cu in 17-4 PH. However, in the engine components, the maraging steels would appear to be ideal candidates for the application of this EB technique since the contents of both Cr and Mn are low enough for control, and due to the high strength applications the inclusion contents are critical. In the related applications cited above the long-term solution would appear to be the development and adoption of alternative alloys which are more suited to the refining system. At the same time, it appears from the literature that the requirement for an Mg content in superalloys which have been refined to this extent is far from proven and before accepting that this is a problem in EB, we should establish the real alloy requirement.

Extending the above technique into the superalloys raises the question of the reliability of extrapolations of the thermochemical data into regions where it has not been experimentally verified. The principal oxide inclusion in the superalloys is alumina and available data indicates that the compositions which will not precipitate this oxide on freezing are below 0.1 ppm oxygen for aluminium contents of approximately 1 - 3 wt% in a typical pure gamma prime alloy such as Rene 95. The possible error in such a computation is considerable, however, since the composition is in a range where the interaction parameters are a strong function of aluminium concentration. Some support for the estimation can be obtained from the technique being developed for the analysis of inclusion content by the EB button melting method. This technique relies on floating all of the inclusion content of the sample, during an EB melt where the temperature is controlled close to the liquidus. In principle, if the method is successful the metal below the floated inclusion raft will contain no inclusions, but will have a composition close to the saturation solubility of the oxide at the liquidus temperature. It has been found that these compositions are in the range indicated above.

Given the above hypothesis, we must examine the possibility of producing the required compositions in a practical EB system. The inclusions which exist at temperatures above the liquidus can be removed by the EBCHM, but further oxygen removal is necessary if we are to prevent inclusion precipitation during freezing. This composition change can only be accomplished in the given alloy compositions by the C/O reaction as all other "deoxidation" reactions will result in the formation of an inclusion product. The C/O reaction is capable of lowering the oxygen contents to the required value but only with long exposure times on the hearth and consequent serious evaporative losses. An alternative route would be to treat the alloy in a non-refractory system under argon (e.g. in ISM⁹) with a large excess of magnesium. The alloy would then be processed by EBCHM so as to separate the MgO inclusions,

but follow the separation with enough vacuum exposure to remove all of the residual Mg. Thermochemical estimations of this sequence indicate that it is capable of producing the required lowering of oxygen content to the point at which alumina precipitation will not take place on freezing, and the residual precipitated MgO content will be negligible. It is to be emphasised that although the cost of this route would certainly be higher than existing alternatives, the advantages in using an alloy without oxide inclusions whether for castings, forgings or powder would more than outweigh the process cost increase, and would include the quantum increase in properties which we need. It is also to be noted that one of the advantages of using a combination of ISM and EBCHM is that both processes are admirably suited to a high degree of on-line monitoring and control¹⁰. Manual operations and operator judgement decisions are reduced to an insignificant level leading to a process sequence which has a very satisfactory degree of reliability in quality assurance.

Titanium Alloys

In this system, the approach has been reduced to one in which we have introduced a process step which will remove (either physically or by flotation) the exogenous particles which constitute the inclusion problem in the titanium alloys. The removal of HDI particles has been shown to be rapid and quantitative when the alloy is melted through either EBCHM¹¹ or plasma cold-hearth melting¹² (PCHM) and should the nature of the feed alloy be such as to require removal of HDI, either of these processes can be used. The removal of LDI is more problematical since the defect particles are chemically stable at high temperature and also have a bulk density which is close to that of the liquid alloy. Therefore we must rely on a dissolution mechanism for their removal. The residence time required for the dissolution of a "worst case" LDI i.e. one with high nitrogen, is known as a function of temperature, and several attempts have been made to relate this process time to the conditions prevailing in the hearth regions of both EBCHM and PCHM, using combined models of heat and mass transfer. Such estimations show that the time/temperature function in the hearths of existing commercial facilities is more than adequate to dissolve the "worst case" LDI, provided that it contacts the steady-state fluid regime assumed. It would appear from practical results, however, that the core of the removal problem is not the steady-state design, but instead is the prevention of short-circuiting by particles thrown from the feed end of the system into the ingot casting area. It is possible, by suitable design of the hearth¹³ to accomplish this aim with respect to those particles which are ejected from the melting region by degassing and splatter, but there still remains the problem of particles with positive buoyancy which become trapped in surface flows and are carried into the ingot. It has yet to be demonstrated that this effect can be totally prevented by using a Marangoni barrier created by beam-sweep programming. A more satisfactory way of removing the latter difficulty is the use of a first-melt VAR ingot as the hearth feed, in place of the commonly-used loose mixture of chips, cut scrap, and sponge. In the first-melt ingot, the LDI particles will remain un-dissolved but will be wetted by the liquid titanium alloy pool and therefore will not possess positive buoyancy when they arrive at the hearth. An example process sequence would then be VAR/EBCHM, as compared to the present 3 x VAR or EBCHM/VAR, with the corollary that the use of the EBCHM process as the final step in ingot manufacture would require adequate control on the solidification structure of the ingot. At present, work on these systems has demonstrated

that the proposed route is viable, and since the processes are qualified for manufacture of rotating parts the quantity of alloy melted is now reaching the stage when we can verify that the occurrence of LDI is indeed zero in a production weight of alloy where the occurrence rate in 3 x VAR would not have been zero, thus establishing the superiority of the process in a valid statistical manner.

MELTING AND SEGREGATION DEFECTS.

In respect of this type of defect, there is a considerable difference between titanium on the one hand and steels or superalloys on the other. The titanium alloys are much less sensitive to segregation variables, but the rates at which we are compelled to melt them (dictated by the VAR process heat balance) there is some segregation in all of the alloy compositions. All titanium alloys freeze as simple solid-solution beta structures and most of them have a very narrow freezing range with little solute rejection. As a result, the segregation problems encountered are those of macrosegregation rather than of interdendritic microsegregation -- indeed it is likely that some of the alloys (for example 6Al4V) have such a small freezing range that they solidify with a planar or cellular interface rather than a dendritic one (Fig 3). The macrosegregation defects are found in the final product as regions in which there is a variation in the transus temperature from the predicted norm. Such variations are reasonably easy to detect by etching procedures. They vary from alloy to alloy and also with application in regard to severity since the permitted range of heat treatment temperature with respect to the true transus temperature depends on the specification ruling for the application. We thus have a complex situation in regard to the accumulation of data on segregation defects in that an alloy which is satisfactory for one application may be defective in another. In most cases, however, the segregation can be closely linked to the operating parameters in the VAR process and is hence detectable at an early stage in processing through the use of correct monitoring of the VAR output data. The segregation thus observed takes the form of either beta stabilisation ("beta-fleck") or alpha stabilisation ("alpha-II"), depending on the segregating element. In the former case, the two most important elements are chromium (e.g. Ti-17) and iron (e.g. 10-2-3) segregating with a severity which depends on the VAR pool depth; in the latter the segregating element is usually aluminium with the only significant area being affected that of the final pool to solidify during the ingot hot-topping procedure.

The form and occurrence of the defects outlined above leads to a difficult judgement situation in quality assessment in that the billet material normally will become progressively less defective with distance from the original top of the VAR ingot. It is not possible to define the point at which it becomes acceptable in terms of the VAR operating parameters with a precision sufficient to establish a close rejection level. It is therefore customary to establish a standard excess cut-off by statistical means, with the provision that if a macro-etch test reveals further segregation, then further cut-off is necessary. The entire process is quite wasteful and given the rather arbitrary nature of the procedure coupled with the less-than-perfect control of many VAR furnaces it occasionally leads to the presence of defect material in the part production step. Fortunately, the nature of the two defect types is such that they will elongate during the billet and forging steps and so present a geometry which is very favourable for detection at the part manufacturing stage. They are hence to be regarded as a production delay and cost rather than as a cause of in-service failures.

The segregation defects which commonly occur in steels and superalloys are of a similar practical nature to those described above, but the details of their structure, formation and mechanical effects are quite different. The alloys all have long freezing ranges during which extensive interdendritic segregation will take place. The cooling rate during this process will determine the size and composition of the primary phases¹⁴ which in most cases are crucial to the mechanical properties of the alloy. The dendritic network is rather open and we may readily have fluid flow through the structure, leading to large pools or channels of interdendritic liquid, and conversely to collections of primary dendrites without interspace liquid. In the former, we have a final degree of segregation which is much more extensive than normal, leading to the precipitation of larger-than-normal fractions of primary phases, or also to the precipitation of phases which would not normally be observed in the alloy (for example, eutectic Laves phase or eutectic borides in the superalloys). In the latter we have regions in which there is an almost complete absence of the strengthening elements. Typical modes of appearance for the former type of segregation are freckles, centre-segregation or tree-rings; for the latter are "light-etching areas" or "LEA". As with the titanium alloy case, the degree to which these affect the mechanical properties is a complex function of alloy, application and severity of occurrence. They are all, however, rather more difficult to deal with than in titanium alloys since their causes are more random and more difficult to detect from VAR or ESR operating parameters. Consequently, we are less able to rely on billet or part inspection for their elimination.

A further type of defect is commonly found in the steels and superalloys which has no counterpart in titanium melting, namely the "white spot" defect, so named because of its resistance to the macro-etch solutions used in the alloy inspections. This defect has been extensively studied¹⁵ and it is concluded that the major source of the defect lies in the fall-in of dendrite fragments from the VIM electrodes used in VAR, although under certain circumstances they may also be produced by the VAR process itself from fall-in of the crown region of the ingot. The defect is usually found because of its association with inclusion agglomerations which are detected ultrasonically. The occurrence frequency of these "dirty white spots" in high quality superalloys is normally at a rate of approximately one per ingot in the VIM/VAR process. The occurrence rate of white spots free from inclusions is not known. As with the other types of defect, the significance of the white spot in mechanical terms depends on the application, alloy, defect size, associated inclusions and also its position in the part. At present most end-users have specifications which express in detail the acceptance/rejection criteria for white spots, based on data relating to particular applications. However, since the clean white spots are only detected by etching their surface section, and we have no way of determining the size from this appearance, the restrictions on white spot occurrence through etch detection are possibly too severe in an absolute mechanical sense but at the same time are a necessary precaution. There have been no identified in-service failures through white spots, but the rejection rate in production is such as to make the defect a priority matter in terms of cost.

REMOVAL OF SEGREGATION DEFECTS THROUGH MELTING AND REFINING PRACTICES.

Improvements in the situation outlined above centre around two issues; the control of the solidifying

structure and the reproducibility of the melting/casting method together with the reliability of the process monitoring method used. It has been clearly demonstrated by a number of workers¹⁶ that the limiting factor in the structures obtainable by conventional ingot casting techniques is the heat transfer out of the ingot centre i.e. the ingot centre Fourier number. In practical terms we have now reached the limit of possibilities in this regard through manipulation of the ingot surface heat transfer coefficients by, for example, the use of helium injection in the VAR crucible. Any further progress to be made can be done only through a reduction in the heat input to the ingot. In the consumable electrode processes there is an inherent link between the electrode melting rate, the power input and the consequent heat input to the ingot. It has been found that this combination leads to the situation where we may obtain an ingot with a surface acceptable for forging at a slightly lower rate in VAR than in ESR at an given ingot size. It is for this reason that we have chosen to use VAR in many applications where refining can be obtained by a variety of methods, but where the final ingot step requires control of the solidification structure, as in the triple melt process. The practical limits in the VAR process have been established by the competing requirements of a low melting rate for solidification control as opposed to the need for a high melting rate to minimise the occurrence of the white spot type of defect. As the ingot diameter increases, the range of permissible melting rates becomes progressively smaller, until we reach an ingot diameter at which there is no range of acceptable melting rates. This diameter is dependent on alloy composition and application, but is essentially the maximum size used in present practices in the triple melt route, where the "window" of operating variables in VAR is in consequence, uncomfortably small but acceptable to the customer provided very severe control is exerted on the VAR step. It is clear, however, that this practice is far from ideal and in addition it is highly unlikely that any developments will appear in the future VAR technology which will significantly alleviate the situation.

Many alternative processes and process routes have been suggested for the improvement of this situation. It has been proposed that the addition of alloy powder to the ingot pool would bring about the desired cooling effect, but in this method, the risk of creating precisely the type of defects described above is obviously high. The same criticism may be applied to the various proposals for building an alloy preform by metal spraying, as in the Osprey process, where we have the potential for the required structure refinement by rapid cooling, but at the expense of a high risk of refractory entrapment, and the added penalty of no foreseeable extension to titanium technology. In respect of more conventional routes to large ingots for forging, two new techniques have been proposed; the VADER¹⁷ process and low-enthalpy EB melting¹⁸ (LEEB), in both cases to be applied to alloy which has been refined by the routes described above.

Both of these techniques are designed to reduce the heat input to the ingot to the point at which metal entering the ingot mold has the minimum enthalpy content -- a similar idea to that of the semi-solid casting and injection methods (e.g. rheocasting) which have been used on lower melting-point systems, but so far not in the alloy systems in question at the required quality standards. VADER accomplishes this aim by generating a metal spray from an high current arc following which the spray falls into the mold without any superheating and with some solidification prior to reaching the mold. The process has been found to have its own unique problems in regard to inclusion content and composition

control, but has also demonstrated the potential to manufacture the required structures, in both superalloys and titanium alloys¹⁹.

The LEEB process has not been developed to the same extent as has VADER, but also has shown the potential to manufacture structures with much less segregation and finer grain-size than can be made with the conventional methods. In this case, the required change in heat input to the metal pool is accomplished by a manipulation of the EB heat balance, taking advantage of the fact that in this process the melting rate and the power input to the ingot can be decoupled due to the very high heat loss by radiation from the top surface of the ingot pool.

The most attractive features of these two processes are as follows;

- production of an ingot which can be processed by existing techniques
- use of melting and casting systems which are free from refractory and use only vacuum atmosphere
- easy coupling to advanced refining techniques
- excellent potential for close automatic control and monitoring.
- the potential, in principle, to eliminate all of the sources of defects described above, using relatively small extensions of well-understood state-of-the-art technology.

Possibly the most intriguing feature of these possibilities is that both of the process have already produced ingot material in alloys which are not considered to be forgeable in the conventional sense, but which after this processing proved to have sufficient ductility as to allow conventional forging. We are thus presented with a new range of possibilities in rotating part alloys without the need to invent and qualify new alloys. When this possibility is coupled with the potential for removing all random defects, we have provided the engine designer with a most attractive prospect -- that of being able to make a quantum jump in design without the need for generating an extensive new database.

It is debatable how much improvement in our present practices can be achieved by stricter process control and monitoring. Certainly, much of our engine materials are made in installations which are less than perfect in this regard. However the principle processes of VIM, VAR, and ESR are extremely complex in their internal parameters and leave us little in the way of external parameters with which to judge the progress of the operation. It is clear that in VAR, one of the keys to detecting deviations from an optimum ingot structure lies in the arc behaviour. However, the nature of this parameter is sufficiently complex as to have defied the development of suitably accurate monitoring systems, although we have achieved a moderate degree of process control in this respect. In the ESR furnace, a key control in the maintenance of conditions which avoid random centre segregation is the temperature distribution in the slag layer, but after at least ten years of understanding this fact, we have been unable to develop any real monitoring and control of this parameter, nor indeed is there any reason to believe that we can do so in the foreseeable future, even on theoretical grounds. The VIM process has been improved in a mechanical sense over the years so that its operation is simpler and less costly. However, it is still very much a manual operation with a great deal of the product quality depending on the skill of the operator. The monitoring of the results is very seldom automatic and equally seldom used in any SPC system. To a

large degree, the triple melt process was developed in a very timely manner in reducing our reliance on VIM quality, at least in wrought applications.

All of the processes which we are presently using are mature technologies with many years of development effort behind them, and they have well-defined limitations in both theoretical and practical senses. They do not have the potential for the major advance which we need in regard to the elimination of the critical defect types, and we must conclude that the best progress will be made by concentrating our efforts in development on processes which have at least the potential for these improvements

CONCLUSION

A survey of the defect types which represent the barrier to improvement in engine performance leads to the conclusion that we have reached the limits of our present process routes in both a practical and theoretical sense. The elimination of the critical defect types is best accomplished by concentrating on the new processes represented by EBCHM, VADER and LEEB. These processes offer the necessary potential for producing defect-free alloy at a cost less than that of powder routes, with the potential also for the required level of automatic process control and monitoring. If we follow this development path there is the good possibility of making large advances in engine reliability and performance without the need for any development in new alloys.

ACKNOWLEDGEMENTS

The author gratefully acknowledges the support of the Nickel Development Institute and the Natural Science and Engineering Council of Canada through the provision of a Research Chair during the course of this study. He is also grateful for the assistance of Mr A Schmalz in preparing Fig 3.

REFERENCES

1. Aircraft Accident Report # PB90-910406, 19 July 1989, National Transportation Safety Board, Washington, USA.
2. A. Mitchell; Proc. International Conference on Superalloys, eds. T. Khan and A. Lasalmonie, (ASM Europe, Paris, 1986), 233-241
3. C.E.Shamblen; "Electron Beam Melting and Refining 1990" ed R. Bakish, publ. Bakish Corp, Englewood NJ, USA, 1990, 128 - 135.
4. A. Mitchell and D.W.Tripp; Proc 7th International Conference on Titanium, San Diego, July 1992 to be published by AIME, Warrendale, PA, USA.
5. R.G.Menzies and C. Adaszczik; Proc. Vacuum Metallurgy Conference, eds. L.W.Lherbier and G.K.Bhat (Pittsburgh PA, TMS-AIME 1986), 65 - 73.
6. A. Mitchell and D.W.Tripp; "High Temperature Materials for Power Engineering" eds. E. Bachelet et al (Kluwer Academic Publishers, Boston 1990), 1665 - 1675.
7. S.M.Tilmont and H.R.Harker; "Electron Beam Melting and Refining 1990" ed R.Bakish, publ. Bakish Corp, Englewood NJ, USA, 1990, 135 - 146.
8. S. Fukumoto and A. Mitchell; Proc. Vacuum Metallurgy Conference, ed. L..Lherbier, (Pittsburgh, Sept 1991) to be published, TMS-AIME, Warrendale PA USA.
9. D.J.Chronister, S.W.Scott and D.R.Stickle; Proc AVS Conference, eds. L.W.Lherbier and G.K.Bhat, (AVS/AIME Warrendale, PA USA 1986), 51 - 54.
10. H. Stephan, W Dietrich and H Stumpp; "Electron Beam Melting 1986" ed R. Bakish, publ. Bakish Corp, Englewood NJ USA 1986, 127 - 159.
11. C.H.Entriken; "Electron Beam Melting 1985" ed. R.Bakish, publ. Bakish Corp., Englewood NJ, USA 1985, 40 - 54.
12. W.R.Chinnis; "Electron Beam Melting 1990" ed. R.Bakish, publ. Bakish Corp, Englewood NJ, USA, 128 - 135.
13. C.H.Entriken and H. Harker; US Pats Re 32,932 and 4,750,542; 5-30-1989
14. A.S.Ballantyne, -F Wadier and A. Mitchell; Proc. 6th International Conference on Vacuum Metallurgy, eds. G.K.Bhat and R. Schlatter (AVS, New York 1979), 599 - 624.
15. J-F Wadier, G. Raison and J. Morlet; Proc. Vacuum Metallurgy Conference 1985, ed. G.K.Bhat (AVS, New York 1985) 224 - 231.
also; A. Mitchell; Proc. Vacuum Metallurgy Conference 1986, eds. L.W.Lherbier and G.K.Bhat (TMS-AIME Warrendale PA, USA.), 55 - 61.
and ; J.P.Erdeljac, H.Henein and A. Mitchell; ISS Transactions, 1985, 6, 51 - 63.
and; M.D.Evans and J.F.Radavich; Proc. Vacuum Metallurgy Conference, eds L.W.Lherbier and J.T.Cordy (Iron & Steel Soc AIME, Warrendale PA, USA 1989) 65 - 71.
16. A.S.Ballantyne and A.Mitchell; Ironmaking and Steelmaking J., 1977, 4, 229 - 239.
also; A.S.Ballantyne, J.Kennedy and A.Mitchell; Proc. 5th International Conference on Vacuum Metallurgy, Munich 1976, 181 - 185.
and; A. Mitchell and A.S.Ballantyne; Proc 6th International Conference on Vacuum Metallurgy, eds. G.K.Bhat and R.Schlatter (AVS New York 1979) 569 - 599.
17. W.H.Sutton; Proc. 7th International Conference on Vacuum Metallurgy (Japan Iron & Steel Institute, Tokyo 1982) 2, 1420 - 1428.
18. A. Mitchell, D.W.Tripp, S.L.Cockcroft and C.H.Entriken; Electron Beam Melting 1991" ed R.Bakish, to be published, Bakish Corp., Englewood NJ, USA.
also; C.H.Entriken and H.R.Harker; US Pat 4,838,340; 6-13-1989.
19. Jia-long Xu, Zhi-chao Zang, Ping-wai Fang and Wu-yu Hu; J. Vacuum Sci & Tech. Second Series, 2,(4) Part IV, 1987, 2682 - 2684.

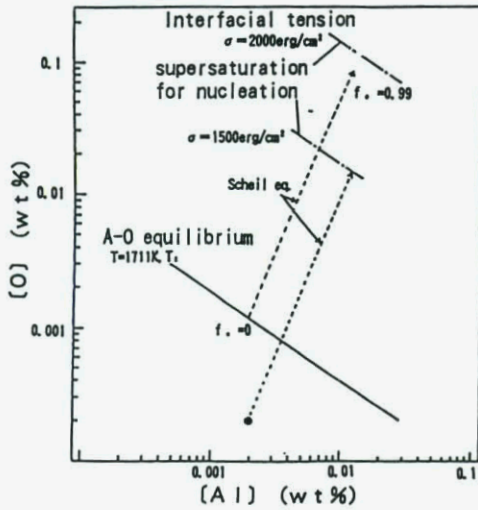

Figure 1. Segregation paths for Al and O in Maraging 250, following the Scheil Equation with the surface parameters shown (f_s is the fraction solid).

The data indicates that no Al_2O_3 precipitation will be observed at the point when the alloy is completely frozen, if the starting composition is; O < 2ppm and Al < 20ppm.

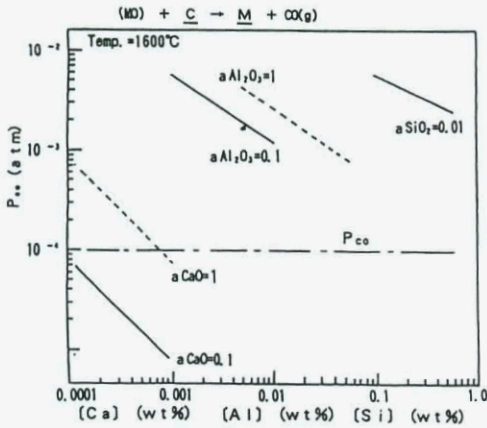

Figure 2. Equilibria in the carbon reduction reactions of interest, illustrating that in EB conditions all oxide inclusions except for CaO will be decomposed.

The data refers to a carbon concentration of 0.01 in Maraging 250.



Figure 3(a). Solidifying surface of CPTi showing the planar/cellular growth. (SEM image).

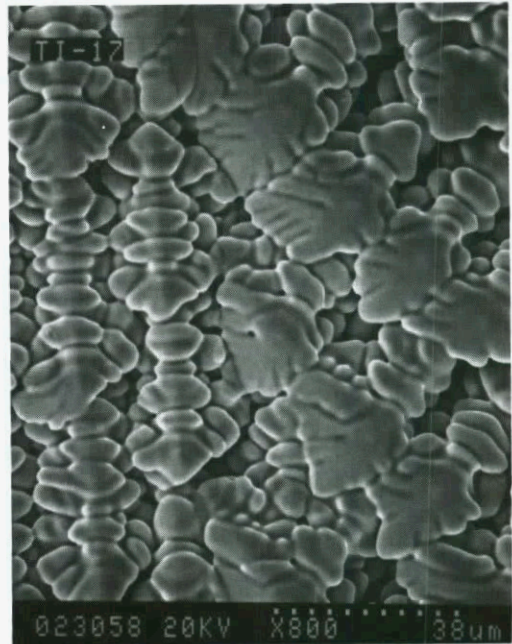

Figure 3(b) Solidifying interface in Ti-17 showing the dendritic nature of the growth. (SEM image).

PROCESS ENHANCEMENTS OF SUPERALLOY MATERIAL

Ronald H. Williams and Kristine A. Lark
Wright Laboratory, Materials Directorate
Wright Patterson AFB, Ohio 45433-6533, USA

Sharon Vukelich, Aeronautical Systems Division
Wright-Patterson AFB, Ohio 45433-6533, USA

Donald R. Parille and Richard W. Salkeld
Materials Engineering, Pratt & Whitney
East Hartford, Connecticut 06108, USA

SUMMARY

Due to the ever-increasing demand for improvements in engine performance and better fuel efficiency, complex high pressure turbine (HPT) blade designs have been introduced into military engines. Greater emphasis has, therefore, been placed on increasing the structural integrity and life of engine components. Material defects must be of a small enough size and sparse enough in population to enable the design of high thrust-to-weight ratio engines. This requirement has demanded the industry attainment of cleaner materials. In order to meet this requirement, possible process improvements were evaluated. Enhancements were incorporated into the melting and casting processes to reduce the size and number of dross defects within high pressure turbine blades. The accomplishment of this goal was through the efforts of a joint United States Air Force, Pratt & Whitney Task Force Team. Process implementation has been successful in reducing the remaining deleterious defects present in directionally solidified single crystal and polycrystalline nickel-base superalloy turbine blade materials. In conjunction with the introduction of melting and casting process improvements, the refinement of non-destructive inspection techniques was investigated.

INTRODUCTION

Turbine blade castings contain occasional material defects due to the inherent nature of the casting process. The need for blades to operate in environments calling for maximum performance has made microstructural control and casting cleanliness crucial. With cyclic fatigue being a life limiting factor for rotating components, the presence of material anomalies promotes initiation sites for fatigue failures. As a result of incidents involving single crystal turbine blades with dross, a joint United States Air Force, Pratt & Whitney "total quality" team was formed to investigate the problem. The team was given the name of "The Single Crystal Castings Task Force Team". Its mission was to evaluate the state-of-the-art in the design, manufacture, and inspection of single crystal turbine blades. Emphasis was placed on evaluating supplier casting processes and control and associated inspection methods. Based on detailed metallurgical investigations, a focus was placed on the cause and prevention of aluminum oxide (Al_2O_3) dross occurrences in blade castings.

The Task Force objective and strategies in this study were three-fold. Emphasis was placed on the identification of the sources of dross, implementation of process improvements and the evaluation of promising state-of-the-art non-destructive techniques.

BACKGROUND

Since the 1960s, high pressure turbine blades for aircraft gas turbine engines have been produced by the investment casting process. The process itself is not new technology, being rooted in the "lost wax process" practiced since ancient times. The design progression of simple, solid blades in first generation equiaxed superalloys to today's complex, multi-cavity blades in single crystal form, have placed increasingly difficult demands on the process to achieve dimensional, quality, and metallurgical conformance to exacting requirements. As currently practiced, therefore, it has become one of the most complex manufacturing methods in use today for engine components. The basic steps of the process are shown in Figure 1. Each operation has its own subset of procedures utilizing customized foundry materials and equipment. Each operation from preparation of master heats to mold construction and through to melting and casting is a potential source of inclusions, typically nonmetallic oxides, or contaminants in the final product. As a consequence, stringent process controls and sophisticated blade inspection techniques have been developed to assure the required quality level is consistently achieved.

Dross is a specific category of defect which falls within the general class of inclusions. It can be simply defined as an oxide material formed in molten superalloy from reaction of the metal with oxygen or oxides. Dross can occur from one of numerous sources associated with the melting and casting operations. A listing of these is shown in Figure 2. The formation and entrapment of dross in blade castings has been a concern for over 20 years, particularly with the introduction of directionally solidified (DS) technology. This process, schematically shown in Figure 3, increased by an order of magnitude the exposure time of molten superalloy to the furnace environment and the ceramics comprising blade molds and cores. Alloying elements such as aluminum and hafnium in Pratt & Whitney DS materials, (Figure 4) are strong oxide formers and they can reduce system ceramics, particularly those containing silica, to form dross.

Process improvements incorporated over the years by blade casting suppliers have been effective in reducing these alumina and/or hafnia-based dross occurrences. This Task Force program sought to drive the investment casting process to its next level of clean "dross-free" performance.

APPROACH

The approach taken to accomplish this next level of dross reduction was a) characterizing dross, b) conducting screening experiments, c) performing foundry studies, d) implementing process changes and e) measuring blade quality improvement. Strategies to pursue each of these tasks were developed in joint meetings of the Task Force and casting suppliers. A systematic review of the casting process identified a number of variables for further study. These are shown, in generalized form, in Figure 5. Experiments conducted in a casting research laboratory setting, supplemented with experimental foundry evaluations, were used to define factors for investigation in the production foundry. Statistical analysis tools, including Taguchi Design of Experiments, were employed to establish the significance of factors and levels evaluated in the foundry. Analysis of historical data, i.e., blade inspection results reporting dross occurrences, was also performed to establish links to process parameters. Following confirmation casting trials, factors having a significant impact on dross reduction were implemented in the manufacturing cycle.

Additionally, a decision to utilize electron beam cold hearth technology in the preparation of master heats was taken by the Task Force.

DROSS CHARACTERIZATION

An extensive metallographic study was conducted as part of the Air Force, Pratt & Whitney Task Force Team effort. Its objective was to examine the external and internal surfaces of single crystal turbine blades for dross indications to determine dross frequency, location, occurrence/relationship, orientation, and the effect of alloy chemistry, blade size and configuration on the dross formation. Over 500 blades were examined. Little or no external surface dross was found; however, all blades had received surface removal treatments prior to fluorescent penetrant inspection (FPI). These blades were then wire Electro-Discharged Machined (EDM) fillet-cut. Slightly high quantities of dross were found on the inner walls of blades, relating to an absence of surface treatments. The composition of the dross was identified to be predominantly Al_2O_3 , with the presence of nickel and chromium oxide. In other studies, local concentrations of elements characteristic to the supplier's particular process were also noted. With these analyses, it was determined the master heat melting and foundry remelt processes were the primary sources for dross. Mold/core and solidification effects were secondary. Two distinct dross morphologies were observed, as shown in Figures 6 and 7. One type is massive and lacy with a network penetrating into the surface. Less than ten percent of the internal dross observed fell into this category. The other more commonly observed type

was a surface dross film, which was shallow in depth, extending not more than 0.005 inch from the surface. It was observed that the shallow dross is typically aligned longitudinally with the primary blade orientation. No strong alloy chemistry effects were observed on the number of indications.

MASTER MELTING

Vacuum Induction Melting (VIM) is the primary melting process for most nickel-base superalloys used in today's engines. As such, it plays a key role in the quality of the finished parts. The process is relatively flexible, featuring independent control of time, temperatures, pressure and mass transport through melt stirring.^{1,2,3} It is an excellent process to produce a product where the chemistry of the alloy needs to be controlled tightly. A schematic of a VIM furnace for master melts is shown in Figure 8. In the vacuum induction melting process, a charge of typically 3,000 to 15,000 pounds is placed into a ceramic crucible. The crucible is surrounded by an induction coil and, with the application of power, the metal is heated to the desired temperature. During this heating and melting process, the molten metal is in contact with the walls of the ceramic crucible. The melting crucible material is not inert, therefore, contamination of the melt can take place by chemical reactions, whereby the more reactive elements in the alloy break down the crucible and form oxides. The crucibles may also deteriorate through spallation resulting from mechanical and thermal stresses. This results in particulates of the crucible contaminating the melt. In many instances, dross stringers are found attached to these particles. Upon reaching the desired melt temperatures, the crucible is tipped and the metal pours out over the lip of the crucible into a waiting ingot mold. Some of the contaminants will float to the back of the crucible, but unfortunately, many oxides will enter the ingot molds and may cause dross in subsequent blade castings. To reduce the frequency of inclusion/dross particles entering and residing in remelt ingot stock, melt shops have devised molten metal filtration schemes utilizing porous ceramics. These ceramic filters have been very effective in improving VIM ingot quality in recent years. However, as a result of our finding that the master heat remains a major source of dross in blades, new development work was undertaken to upgrade materials processing and equipment as well as filtering technology.

The cleanliness of alloys used for aerospace applications is an industry-wide issue. The United States Air Force has sponsored programs to evaluate the capability of the Electron Beam Cold Hearth Remelt (EBCHR) process to produce clean nickel-base superalloy ingots. The results from these programs have been promising and have shown improvements in the cleanliness of EBCHR ingots when compared to VIM starting stock.^{4,5} A schematic drawing of an EBCHR melt facility is shown in Figure 9. In the EBCHR process, ingots are cantilevered above the water cooled copper hearth. Electron beam guns are concentrated at the ends of the charge and the alloy is melted into the hearth. While the ingot is being melted, the guns alternately concentrate on the molten pool to maintain the desired level of superheat and, more importantly, the beam pattern acts as a dam to hold back contaminants floating near the surface. These contaminants are prevented from entering the ingot mold and end up harmlessly in the hearth rather than in the ingot. The EBCHR process has three distinct advantages over the VIM process. First, it must operate in a hard vacuum, thereby increasing refining and prohibiting system leaks; second, by melting in a copper container rather than a ceramic crucible, there is no chance of alloy contamination by chemical reaction or crucible spallation; third, the dam effect of the electron beam guns during pour is capable of reducing inclusion of oxides that are present in the starting charge. EBCHR lends itself as an ideal secondary melting process to improve the VIM electrode product and is being used for many Pratt & Whitney blade castings.

ASSESSMENT OF IMPLEMENTED PROCESS IMPROVEMENTS

As part of the Team's effort, an assessment was made of blade yield and quality improvements resulting from implemented process enhancements. Quality data based on the percentage containing dross defects called out by the supplier's FPI revealed the following improvements: In general, the percentage of scrap dropped by 50 percent when comparing blades cast from VIM ingot to VIM + EBCHR ingot. When comparing blades cast from VIM + EBCHR ingot to blades cast from this material combined with improved master melting and foundry process methods, blades rejected for containing dross dropped an additional 25 percent. Advanced molten metal filtration technology and modified mold and gating designs were instrumental in achieving these cumulative dross reductions.

To further quantify the effects of process improvements on the reduction of dross, a blade fillet study was conducted to assess the frequency of dross on internal blade wall surfaces. The blades were wire EDM filleted, visually inspected, and metallographically examined for dross on the blade internal wall. Just as with external surfaces it was observed that the frequency and size of internal dross were significantly reduced.

In summary, process modifications have resulted in extraordinary

improvements in the quality of high pressure turbine blades. Significant yield increases have been realized by the casting suppliers and have been attributed to the overall reduction of dross by at least 50 percent. Near "dross-free" quality products are now available; however, as engine rotational speeds and operating temperatures continue to increase, future blade designs and materials will require further reduction in size and frequency of dross. Far term approaches need to be evaluated and one such approach might be Electron Beam Remelting (EBR) at the casting centers in place of the currently used VIM.

NON-DESTRUCTIVE EVALUATION

A major part of this study and its success stemmed from the non-destructive inspections utilized by the casting producer and user to detect dross. Stringent non-destructive testing methods have been developed to detect defects that could affect the reliability of high pressure turbine blades. Among these are fluorescent penetrant and radiographic inspection techniques. Fluorescent penetrant inspection methods can vary significantly depending on established sensitivity requirements. Detection, however, requires the dross to be surface connected and of sufficient dimension to accommodate entry of the penetrant. Sensitive, but conventional, radiographic inspection methods are being used for subsurface and internal surface dross detection. A variety of techniques were attempted and the following describes the results.

TESTING TECHNIQUE	OBSERVATIONS
Ultrasonics	Incentive to internal dross
Electronic Potential Drop	Internal probe required. Lacks access and sensitivity.
Eddy Current	Might be applicable to deep dross in focused area.
Radiographic Computed Tomography, (X-ray CT)	May be applicable to focused area.
Enhance Digital Radiography/CT	Promising technique for dross and wall thickness.
Scanning Laser Acoustic Microscope	Slow and costly
Borescope Visual Inspection	Slow, high false call rate.

Based on in-depth assessment of these non-destructive testing techniques, the following conclusions were drawn: a) destructive analysis of turbine blades demonstrated enhanced digital radiography is more applicable to whole field volumetric detection of dross, b) X-ray CT and eddy current techniques appear to be more applicable to focused detection of dross or a back-up to digital radiography, and c) X-ray CT has a major potential advantage over current ultrasonic inspection techniques to measure wall thickness and image internal geometry. Applied research is continuing.

REFERENCES

- 1) G. L. Erickson, K. Harris, R. E. Schwer, "Optimized Superalloy Manufacturing Processor Critical Investment Cast Components", Cannon-Muskegon Corporation, Muskegon, MI, presented at the 1984 TMS/AIME annual meeting, Los Angeles, CA.
- 2) R. G. Menzies and C. B. Adaszczik, "Clean Melting of Ni-Base Alloys-A User's Viewpoint", Proc. of Conf. on Specialty Metals Melting and Processing, Pittsburg, PA, 1986, General Electric Company, Evendale, OH.
- 3) M. Fassler, Pratt & Whitney, private communication.
- 4) C. E. Shamblen, S. L. Culp, and R. W. Lober, "Superalloy Cleanliness Evaluation Using the EB Button Melt Test," Proc. of Conf. on Electron Beam Melting and Refining State of the Art 1983, R. Bakish, Ed., Bakish Materials Corp., 1983, pp. 61-94.
- 5) E. E. Brown and R. W. Hatala, "Electron Beam Refining of Nickel-Base Superalloys," Proc. of Conf. on Electron Beam Melting and Refining State of the Art 1983, R. Bakish, Ed., Bakish Materials Corp., 1983, pp. 103-117.

ACKNOWLEDGEMENTS

The authors would like to thank Mrs Marianne Ramsey, Mrs Teresa Low and Ms Susan Dilworth of the Wright Laboratory, Materials Directorate and Ms Nancy Giampolo, Pratt and Whitney, for editorial assistance and preparation of the manuscript. The authors also wish to thank the

following personnel from Pratt & Whitney Aircraft for their technical assistance during membership of the Single Crystal Castings Task Force Team:

Johnny Adamson
 Larry Anderson
 Chuck Biondo
 Steve Cargill
 Carl Demore
 Don Deptowicz

Mike Fassler
 Maury Gell
 Bill Gostic
 Ted Harris
 George Hood
 Clay Moran
 Bob Parker
 Bill Plank
 Kevin Smith

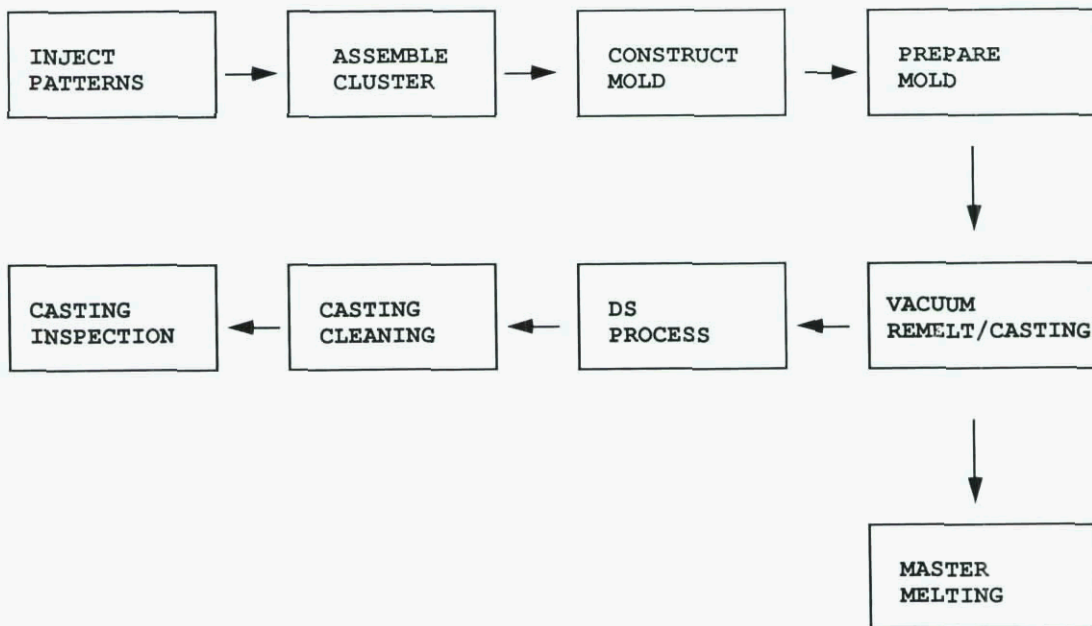
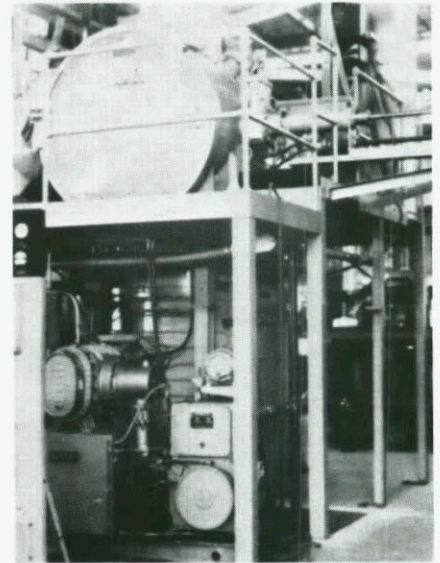
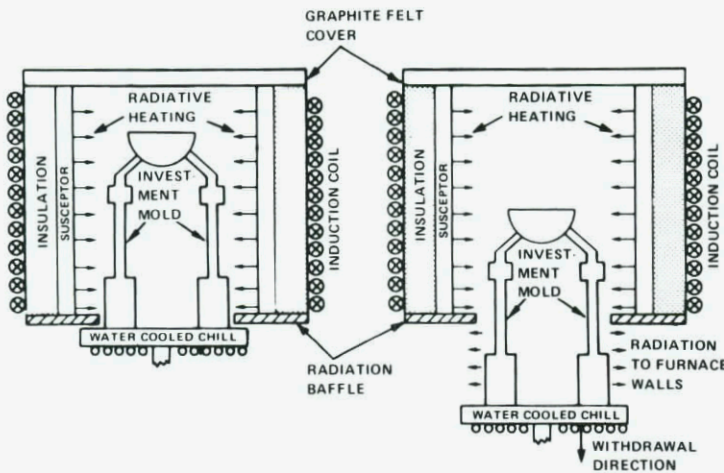

FIGURE 1: Basic steps for DS blade investment casting.

- Alloy Master Melt Production
 - Raw Materials, Revert
 - Ceramics - Crucible, Tundish
 - Alloy Oxidation - Vacuum Leaks
- Alloy Remelt at the Casting Stand
 - Alloy Oxidation - Vacuum Leaks
 - Crucible Ceramic Integrity
 - Crucible Cross Contamination
- Directional Solidification Casting Process
 - Core/Shell Integrity - Inclusions
 - Core/Shell Decomposition - Reaction Products
 - Ceramic/Metal Reactions in the Mold

FIGURE 2: Potential sources of dross in castings.



Typical Production
D.S. Furnace

FIGURE 3: Directional Solidification Process

Wt. %	PWA 1422	PWA 1480	PWA 1484
C	0.14		
Cr	9.0	10.0	5.0
Co	10.0	5.0	10.0
Mo			1.9
W	12.5	4.0	5.9
Re			3.0
Ta		12.0	8.7
Nb	1.0		
Ti	2.0	1.5	
Al	5.0	5.0	5.7
Hf	2.0		0.1
B	0.01		
Ni	R	R	R

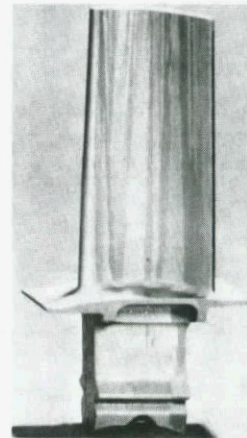

Polycrystal
PWA 1422

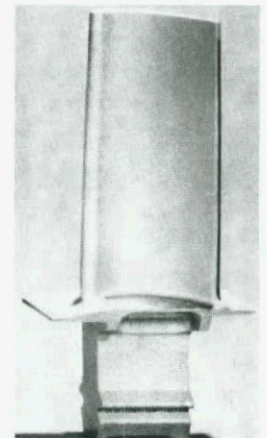

SingleCrystal
PWA 1480,
PWA 1484

FIGURE 4: Directionally solidified superalloy compositions.

Alloy Master Melt	Alloy Remelt	Blade Mold	DS Process
Melt practice	Crucible composition	Composition	Equipment features
Melt formulation	Crucible condition	Construction	Chillplate condition
Filtration	Melt practice	Gating	Furnace environment
Equipment features	Filtration	Degassing	Mold heating cycle
EBCHR	EBR	Firing	Mold cooling cycle

FIGURE 5: Process variables examined for dross reduction

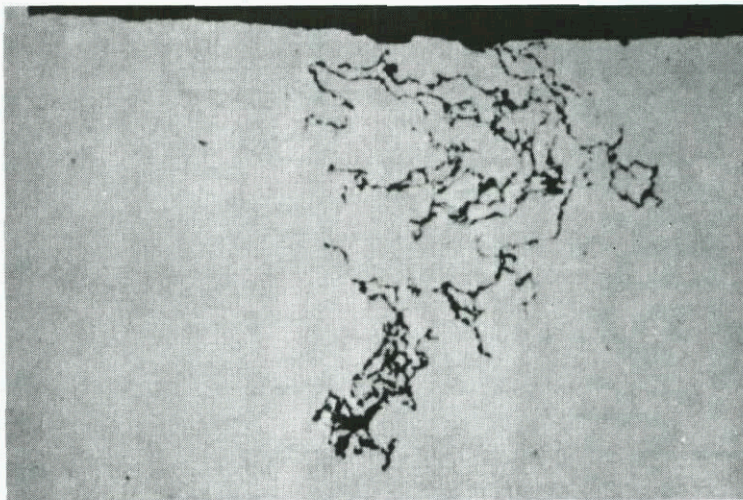

FIGURE 6: Lacy dross film penetrating casting surface. Mag 200X



FIGURE 7: Shallow surface dross film. Mag 200X

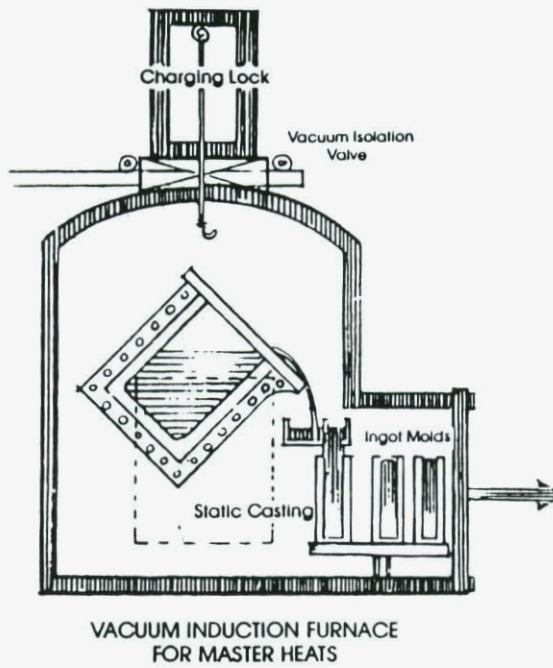

FIGURE 8: Vacuum Induction Melting Furnace.

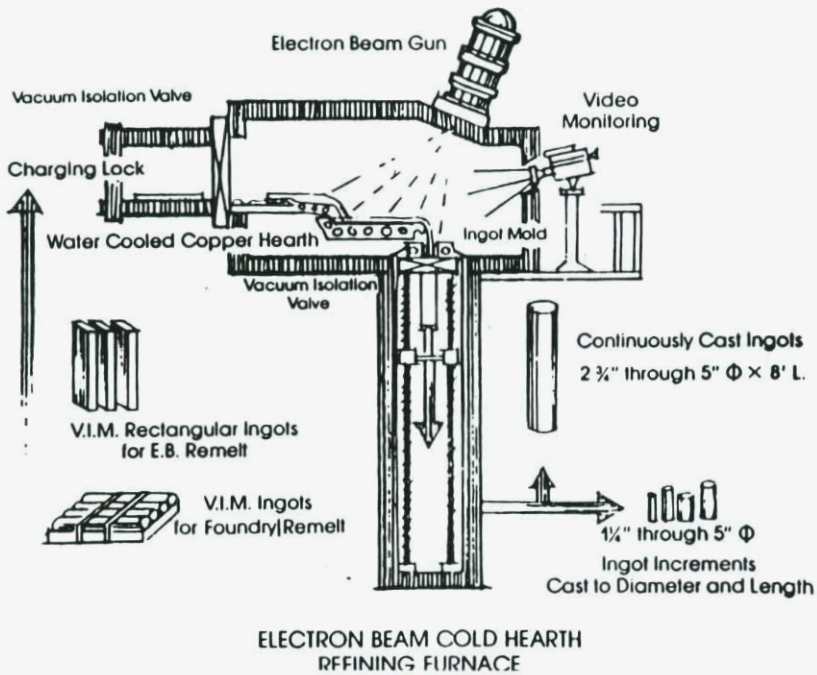

FIGURE 9: Electron Beam Cold Hearth Refining Furnace.

THE CONTROL OF CLEANNESS IN POWDER METALLURGY MATERIALS FOR TURBINE DISKS

by

G. Raison
Imphy S.A.
Techny
58160-Imphy
France

INTRODUCTION

Among the principal factors which determine the performance of aeronautical gas turbines are the mechanical and thermal loads supported by the rotating components. Progress in this area over the years required the use of alloys which became more and more difficult to produce by conventional ingot metallurgy. At the end of the 1960's, this led to the introduction of powder metallurgy techniques for the manufacture of these critical rotating parts.

Original hopes that the improved properties could be combined with lower production costs soon revealed to be unrealistic, and powder technology has rarely been substituted for conventional metallurgy in an existing component. Its introduction has rather been restricted to new programs, where it is justified by the improved properties made possible by increased additions of strengthening elements and better control of thermomechanical processing.

The first disks produced industrially by this route were mounted in military engines manufactured in the U.S.A. by Pratt and Whitney (F100) and General Electric (F404). Since then, their use has been extended to other engines. From the end of the 1970's, a similar approach was followed in the ex-USSR, where powder metallurgy is now widely employed. Europe seems to be lagging somewhat behind, since the first engines using this technique are currently undergoing industrial development, the largest program being SNECMA's M88 turbine.

1 - THE CONCEPT OF CLEANNESS IN POWDER METALLURGY

For temperatures up to 600°C, the alloys produced by powder metallurgy are little different from conventional materials in terms of fracture mechanics (Initiation and propagation of fatigue cracks and rapid fracture). However, the fact that they are used at higher stress levels automatically reduces the size of the critical defect which can lead to a macroscopic crack under low cycle fatigue conditions. This is illustrated qualitatively in figure 1 [1,2].

Above 600°C, environmental interactions become important, and alloy composition and microstructure have an increasingly significant effect on the temperature dependence of crack propagation rates.

The increase in operating temperatures of rotating components, together with the integration of damage tolerance requirements, have led to the development of specific alloys.

Because of the extreme homogeneity of powder metallurgy products, the principal defects which can give rise to fatigue cracks are exogenous inclusions, either directly if they are inert, or via their reaction products if they interact with the matrix.

In the case of argon atomized powders, which are the most commonly used, the origin of these inclusions has been able to be attributed to the following sources :

- fragments of furnace refractories;
- suspended inclusions entrained with the melt;
- metallic powder particles of other grades, whose effects can vary greatly, depending on their composition;
- argon occluded in the powder particles during atomization, and which can form bubbles of significant dimensions during thermomechanical processing or during the final heat treatment;
- organic or inorganic particles from the environment, or introduced during the various conditioning operations.

It is unrealistic to imagine a powder totally devoid of inclusions. It is more appropriate to speak in terms of a powder whose cleanness is satisfactory for a given application. Indeed, this is the true definition of quality. Product specification must be the result of close collaboration between the designer and the supplier.

Since powders contain billions of particles per kilogram, a statistical approach is required, cleanness being represented by a "concentration/size" distribution curve. The method to be adopted to obtain a powder of guaranteed cleanness is then as follows :

- a clean powder must be produced, i.e. one with as low an inclusion distribution as possible, taking into account the processes employed;
- by process control and non-destructive inspection, it must be ensured that this "normal" distribution is not modified in the range of harmful inclusion sizes.

In these conditions, the guarantee cannot be applied to the powder itself, but to a densified product not liable to subsequent contamination.

2 - CLEANNESS ASSESSMENT TECHNIQUES

The techniques employed are varied and are applied either directly to the powders, in which case they are specific to powder metallurgy, or to the consolidated products. The latter methods are also used for conventional products, and are simply adapted for the specific features of PM materials.

2.1 - ELUTRIATION

The principle of this method is indicated in figure 2. A powder sample weighing from a few hundred grams to 1 kg is sieved into narrow particle size fractions (diameter ratio 1.25 between successive fractions). Each size fraction to be examined is placed in suspension in a vertical water flow.

For a given size, any particles whose density is significantly less than that of the metal are entrained by the current, and are collected on a filter for subsequent counting, possibly completed by scanning electron microscopy examination and microprobe analysis. In order to yield valid results, it is essential to respect a rigorous operating procedure. It is then possible to collect exogenous particles larger than 50 μm . However, the technique does not reveal inclusions significantly larger than the powder size, soluble inclusions, those attached to a metal particle, or metallic particles of different composition [3].

As will be seen below, elutriation represents a powerful means of monitoring plant and process performance. Examination of the collected inclusions often reveals the source of the contamination [4]. As a routine tool, elutriation offers a rapid means of verifying the consistency of results.

2.2 - CHEMICAL DISSOLUTION

This technique is applied to the powder, to take advantage of the dispersed state. The metal matrix is selectively dissolved, leaving the inclusions intact, and these are subsequently collected by filtration, weighed, and possibly subjected to additional examinations. Theoretically, this technique separates all the inclusions, but in reality, certain of them are also dissolved. It thus represents only a relative means of quantifying the cleanliness.

The techniques described below apply only to consolidated products.

2.3 - MICROGRAPHY

This is the exhaustive technique *par excellence* It enables counting and identification of all types of inclusions or structural alterations due to reactive inclusions. However, as will be seen below, its sensitivity is extremely low.

2.4 - ELECTRON BEAM BUTTON MELTING

The principal of the method is explained in references [5] and [6]. A bar of the material to be evaluated is drip remelted into a water-cooled copper crucible. By controlling the heating cycle and electron beam displacement, the decanted inclusions are concentrated into a raft in the center of the button. The raft is subsequently examined in the scanning electron microscope, either *in situ* or after extraction by chemical dissolution of the metal. It is possible in this way to count, measure and analyze all inclusions stable with respect to the liquid metal and greater than about 40 μm in size. This test is relatively rapid, but requires excellent control of the melting and solidification processes. Figure 3 shows two curves, illustrating the distribution of inclusion sizes determined by two different remelters on the same metal [3]. In the case of remelter B, poor process control has led to the refinement of certain inclusions and reoxidation of the liquid metal, to form plates of alumina, whose size has no relation to the original inclusions. High performance EB button melting units, in which the various sequences are controlled by microprocessor, are presently available on the market. [11]

2.5 - ULTRASONIC INSPECTION

PM materials lend themselves particularly well to ultrasonic inspection, since they exhibit remarkable permeability and an extremely low background noise level. Studies on artificially seeded materials have shown that this technique reveals disbonding between the inclusions and the matrix, rather than the inclusions themselves [7,10]. The local conditions resulting from thermomechanical processing therefore condition the relationship between ultrasonic indications and defect sizes. For example, figures 4 and 5 [10] show the influence on the US response of the amount of hot work and the position in a cheese forging, produced from argon atomized Astroloy powder seeded with one particle per cm^3 of 220-250 μm alumina inclusions, then HIP consolidated and upset forged.

An approximate correlation can be established between the indications and defect size for massive non-reactive inclusions, but not for other types. The background noise level for a HIPed and forged material can be estimated to be of the order of 120-140 μm (equivalent flat-bottomed hole), compared to 70-90 μm for an extruded and forged material. This places the limit for the reliable detection of massive non-reactive inclusions at 220 and 140 μm respectively.

In spite of its limitations, the advantage of this technique is the possibility of examining large volumes, and to date, it is the only applicable non-destructive testing method.

2.6 - OTHER TECHNIQUES

A certain number of other techniques are currently undergoing evaluation, but have not yet reached the stage of maturity. These include acoustic microscopy, X-ray tomography, and the examination of thin slices by microfocus X-radiography. A requirement exists for a reliable non-destructive inspection technique for monitoring the critical zones of real components.

2.7 - COMPARISON OF THE DIFFERENT TECHNIQUES

Figure 6 shows the results of cleanness evaluations (number of inclusions per cm^3 greater than a given size) performed by elutriation, micrography, EB button melting and ultrasonic inspection on the same material, i.e. powders $< 125 \mu\text{m}$ and the corresponding densified products. The screen sizes used to classify the powders for elutriation must be multiplied by 1.3 to obtain the mean diameter, since non-spherical particles tend to present their smallest dimension to the sieve. In these conditions, satisfactory agreement is observed between the different methods, each having its specific range of maximum sensitivity :

- 20 to 50 μm for optical micrography;
- 50 to 100 μm for elutriation;
- $> 40 \mu\text{m}$ for EB button melting;
- $> 90 \mu\text{m}$ for ultrasonic inspection.

2.8 - SENSITIVITY OF THE CLEANNESSE ASSESSMENT TECHNIQUES

The material used for comparing the different techniques (preceding section) was deliberately chosen for its relatively poor cleanness, in order to optimize the statistical significance of the results.

In effect, in 1 kg of powder $< 80 \mu\text{m}$, there are about 10^{10} particles. In a cross-sectional area of 1 m^2 in a product densified from the same powder, there are about 10^9 particles, 10^8 of which are in the size range $63\text{-}80 \mu\text{m}$. It can thus be seen that optical micrography is several hundreds of times less sensitive than elutriation for revealing the inclusions which the latter technique can detect. The current cleanness level of TECPHY powders, determined by elutriation, is of the order of 10^{-8} (i.e. well below the

specifications), corresponding to counts of 0 to 5 inclusions per test in the size range 63-80 μm . Elutriation is thus already employed at the limit of its sensitivity, while optical micrography does not appear to be a useful means of quantifying the concentration of massive inclusions of large dimensions, and this is confirmed by experience.

Similar reasoning can be followed for EB button testing and ultrasonic inspection. The determination of a cleanliness diagram with a minimum degree of accuracy demands the examination of large quantities of material, involving tens or even hundreds of kg. Moreover, this is the situation for inclusion sizes at the acceptability limit, the problem being even more arduous for larger sizes, for which the counts and specifications are several orders of magnitude lower still.

This problem will be further discussed in the section dealing with inspection.

3 - PROCEDURE EMPLOYED AND RESULTS OBTAINED

As already mentioned, a powder metallurgy component with a cleanliness level satisfactory for a given application is characterized by an acceptable defect distribution and by a Quality Assurance plan which proves it. This result is obtained via a three-pronged procedure involving :

- powder manufacture;
- powder conditioning and processing;
- inspection.

3.1 - MANUFACTURE OF POWDER OF THEORETICALLY OPTIMUM CLEANNESS

This requires adequate equipment, well-controlled processes and appropriate training of personnel.

3.1.1 - Equipment

The equipment must satisfy a certain number of unanimously accepted rules, such as the use of stainless steel containers, powder conditioning under neutral atmosphere, or the prohibition of direct contact between the powder and any organic material. To these should be added a rule of simplicity and reliability of design. Particular attention must be given to two problems :

- Contamination by metal powders of other grades, which may be extremely harmful, depending on their composition, and which are highly difficult or

even impossible to detect. The only solution appears to be the use of dedicated equipment for a particular type of alloy.

- Conditioning involves multiple connections and disconnections of containers and capacities, which are potential sources of contamination. The solution adopted by TECPHY is to perform conditioning operations in a class 10 000 clean room, which has revealed to be much less of a constraint than might be thought.

3.1.2 - Control of processes and training of personnel

These two aspects go together. However well designed an equipment, its optimization, and that of the associated operating procedures, is above all else a matter of experience. Sources of contamination have been identified and the appropriate solutions implemented. Improved process control has also significantly reduced unscheduled stoppages, trouble-shooting operations being potential sources of contamination.

3.1.3 - Cleanness levels obtained

As an example, figure 8 shows the results of elutriation measurements on 11 consecutive powder batches produced by TECPHY. Considering the scatter inherent in the method (cf. § 2.8), these results indicate a consistently satisfactory cleanness level.

3.2 - ELIMINATION OF UNACCEPTABLE DEFECTS AND NEUTRALIZATION OF THOSE WHICH CANNOT BE DETECTED WITH CERTAINTY

Many attempts have been made to remove large inclusions by various pneumatic, electrostatic or impingement processes. Because of their poor efficiency, which is several orders of magnitude too low, together with their intrinsic complexity, itself a potential source of contamination, these techniques have so far not been adopted [8]. The only process in current industrial use is the elimination of the coarse powder fraction, together with its inclusions, by sieving. However, it should not be overlooked that the inclusions are generally not spherical, and the largest dimension of those remaining will be equal to the sieve size multiplied by a shape factor, or aspect ratio, which experience has shown to be about 1.6. In practice, powders for rotating parts are sieved to below between 45 and 125 μm , depending on the alloy and the intended application.

A certain number of defects can be caused by poor bonding between powder particles, due to organic inclusions or metallurgical segregations. Such defects are practically impossible to detect by NDI techniques [10], but various studies have shown that they can be rendered harmless by large amounts of mechanical work [9]. This deformation can be introduced by

forging after HIP densification, or by extrusion, the latter process offering certain additional advantages.

3.3 - INSPECTION DURING MANUFACTURE AND ON FINISHED PARTS

Inspection operations have two major objectives :

- a) To verify the consistency of the operating parameters, which guarantees the quality of the powder and semi-products consolidated by HIP or extrusion. The techniques employed are elementary analysis (including gases), elutriation or selective chemical dissolution (on the powder), and micrography and ultrasonic inspection (on consolidated semi-products). They may be completed by other examinations, involving the manufacturer's know-how.
- b) To detect accidentally defective parts (cracks, unacceptably large inclusions). This type of inspection is similar to that employed for conventional components, and involves the same techniques. However, the latter must be adapted to the size of the defects to be detected. In particular, although ultrasonic inspection is generally facilitated by an extremely fine and homogeneous microstructure, detailed studies are required to establish a valid basis of reference.

4 - CONCLUSIONS

Throughout this article, it has been endeavoured to emphasize the methodology adopted in order to guarantee the quality of powder metallurgy components. This procedure requires close collaboration between the powder producer and the aircraft engine manufacturer.

The investigations performed and the results obtained to date have enabled PM technology to be successfully employed for the high temperature rotating components of SNECMA's M88 engine, the first major application of its kind in France and in Europe. This program, which is currently entering the industrial stage, should be followed by other important developments.

Nevertheless, cleanness remains only a relative concept, and future generations of "ultra-clean" powders will require extensive work on both manufacturing processes and inspection techniques.

REFERENCES

1 - P. WILDGOOSE & CALL

"Powder Metallurgical Innovations for Improved Hot-section in Aeroengine Applications". Powder Metallurgy 1981 n° 2

2 - G.W. KONIG

"Comparison between the Properties of Conventional Wrought and Powder Metallurgical Alloys for Turbine Disc Applications". AGARD Conference Proceedings n° 368

3 - O. FARAL - G. RAISSON

"Propreté des poudres de superalliages" Marché STPA 85-015 Rapport Imphy n° 86/29 juin 1986

4 - C.E. SHAMBLLEN & D.R. CHANG

"Effect on Inclusions of LCF Life of HIP Plus Heat Treated Powder Metal Rene 95" Met Trans B vol. 16 B December 1985

5 - C.E. SHAMBLLEN - S.L. CULP & R.W. LOBER

"Super alloy Cleanliness Evaluation Using the EB Button Melt Test" Proceedings of the Conference on Electrobeam Melting and Refining. Stat on the Art 1983 - ed R. Bakish - Reno Nevada November 1983

6 - R.N. JARRETT

"Automated Electron Beam Melting for Superalloy Cleanliness Evaluation" journée ITMA - Paris March 1986

7 - P. BAUDUIN - G. RAISSON

"Propreté des Matériaux obtenus par Métallurgie des Poudres : Examens par Ultra-sons" Marché STPA 83/006 Rapport Imphy n° 85/16 janvier 1985

8 - W. BETZ

"High Performance PM Alloys : The Price of Allowing for High Stresses in Components" Proceedings of PM Aerospace Materials - Bern November 1984

9 - D.R. CHANG - D.D. KRUEGER - R.A. SPRAGUE

"Superalloy Powder Processing, Properties and Turbine Disk Applications" Superalloys 1984 ed. M. Gell & Al. The Metallurgical Society fo AIME 420 Commonwealth Drive - Warrendale - Pennsylvania 15086

10 - COSTEDOAT - MEURTIN - BRUN - RAISSON - CLEMENT

"Quantitative Evaluation of the Cleaness of HIP + Forge Astroloy Disks Produced from AA Powders of Controlled Inclusion Contents" Metal Powder Report vol. 43 n° 10 October 1988

11 - T. PAUCOD - C. DUCROCQ - A. LASALMONIE - F. SCHWARTZ

"High Temperature Materials for Power Engeneering 1990" Liege (belgium) 24-27 september 1990 - COST 501 and 505 ed.

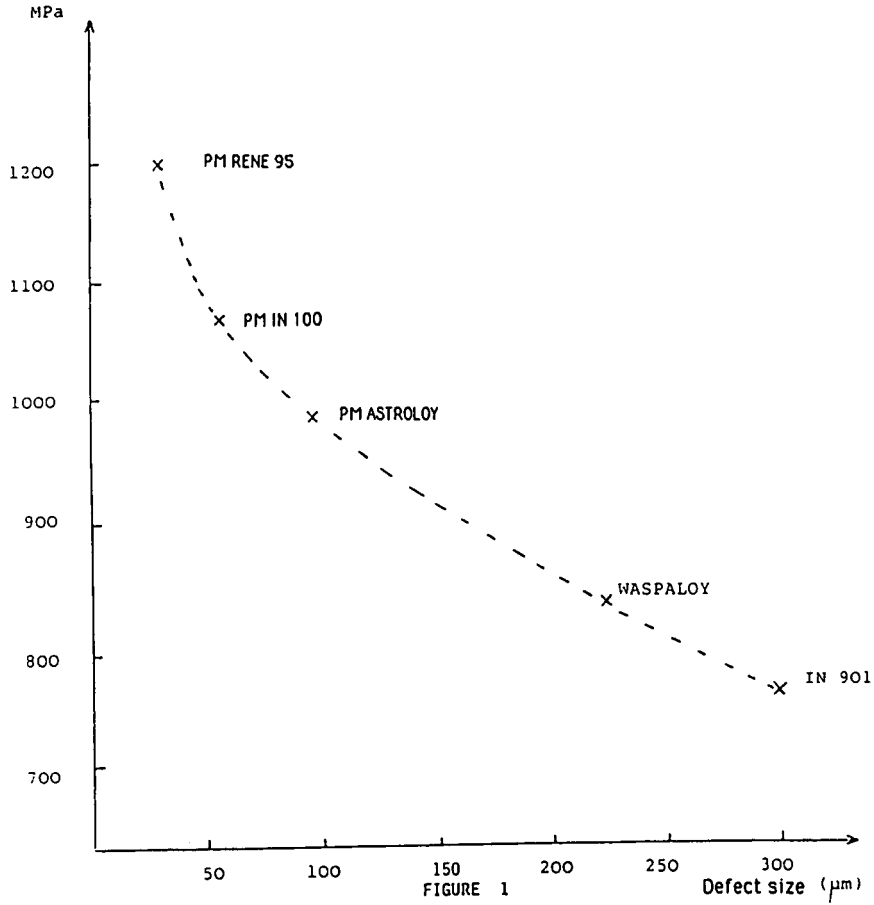

RELATIONSHIP BETWEEN CRITICAL LCF DEFECT SIZE AND YIELD STRENGTH (REF. 1).

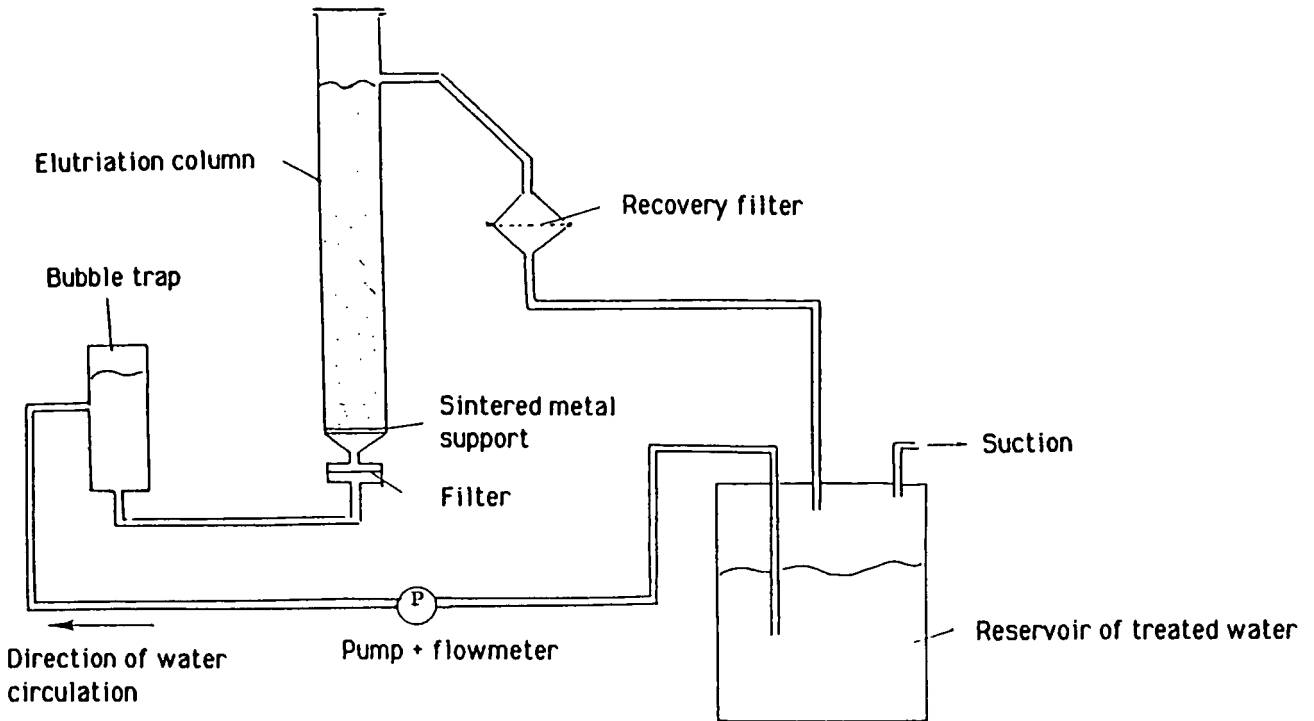

FIGURE 2

SCHMATIC OF AN ELUTRIATION APPARATUS

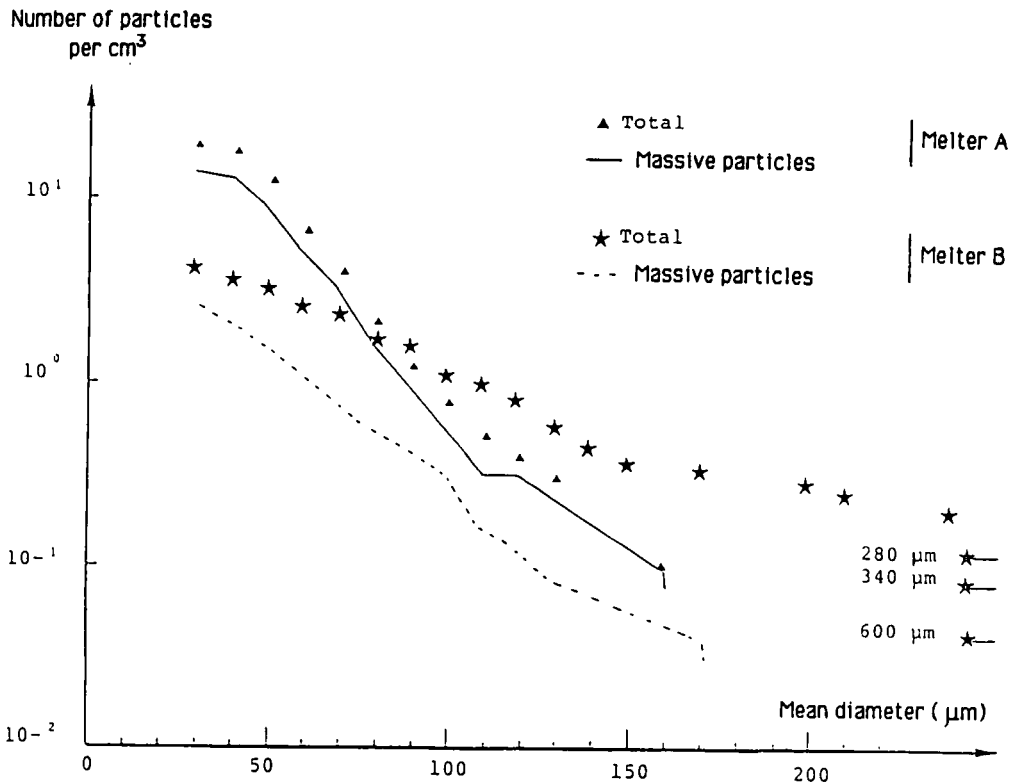

FIGURE 3

BE BUTTON REMELTING - EFFECT OF REMELTING ON THE CUMULATED INCLUSION DISTRIBUTION CURVE ($\xi 125 \mu\text{m}$ POWDER)

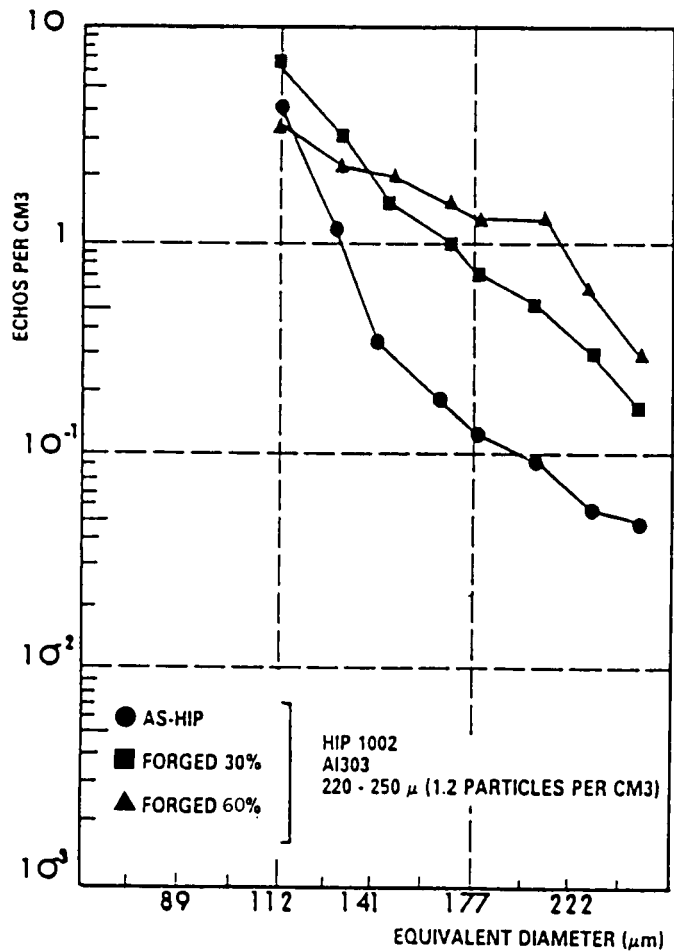

FIG. 4 Effect of hot working

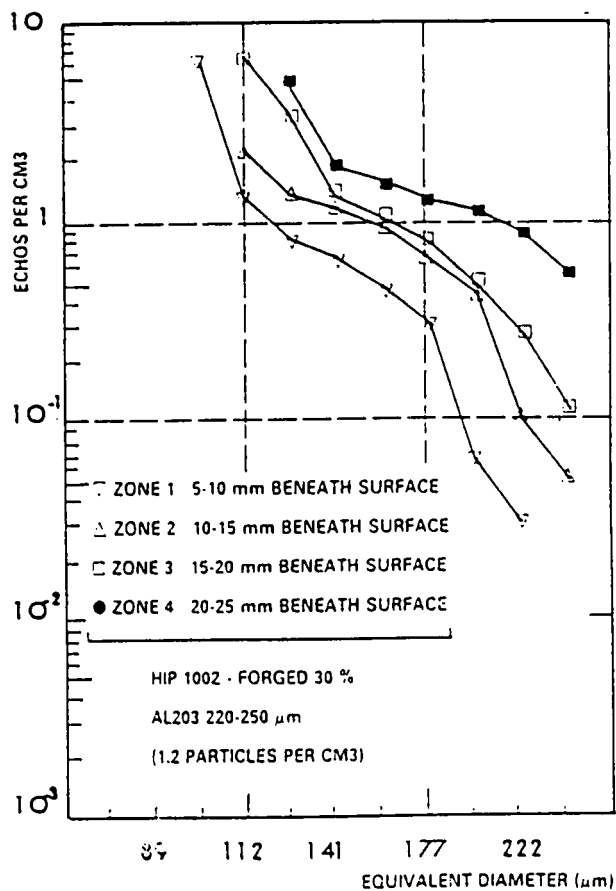

FIG. 5 Effect of zone position (forged 30%)

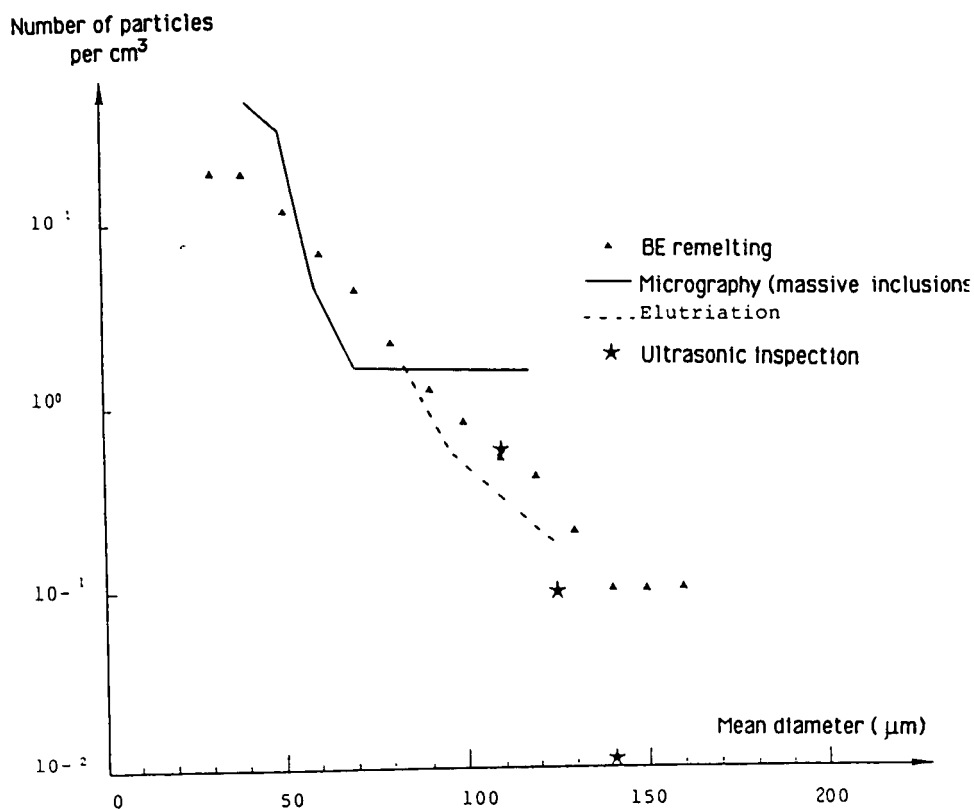

FIGURE 6

COMPARISON OF CLEANNESS EVALUATION TECHNIQUES (ϕ125 μm POWDER)

Number of particles in fraction ($\times 10^{-9}$)

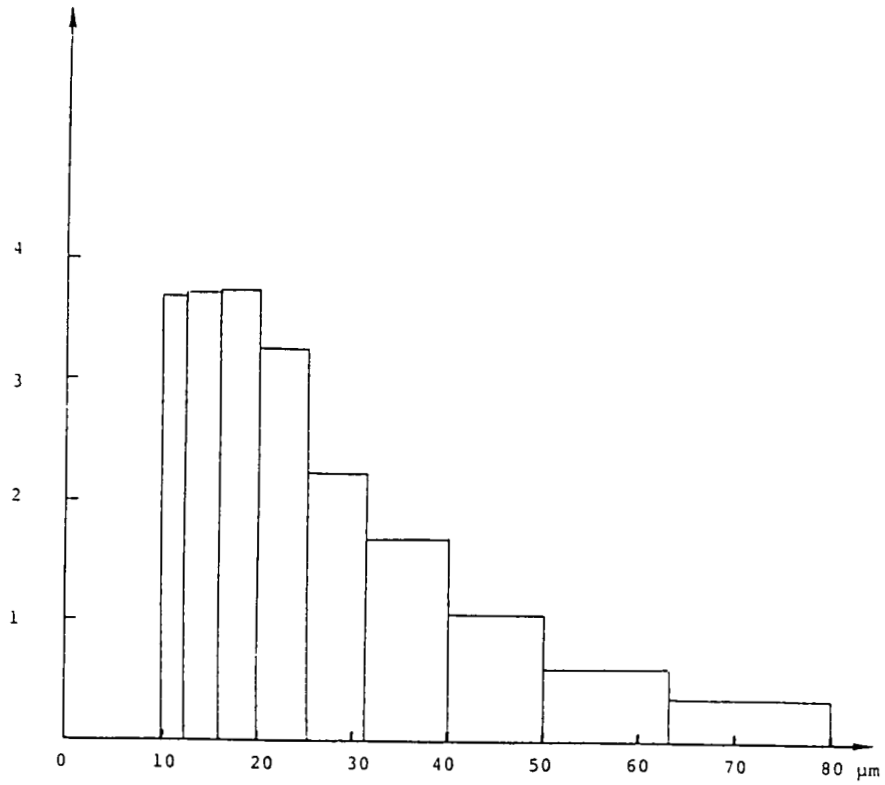

FIGURE 7

FRACTIONAL PARTICLE SIZE DISTRIBUTION FOR POWDERS $\leq 80 \mu\text{m}$

Number of particles per kg

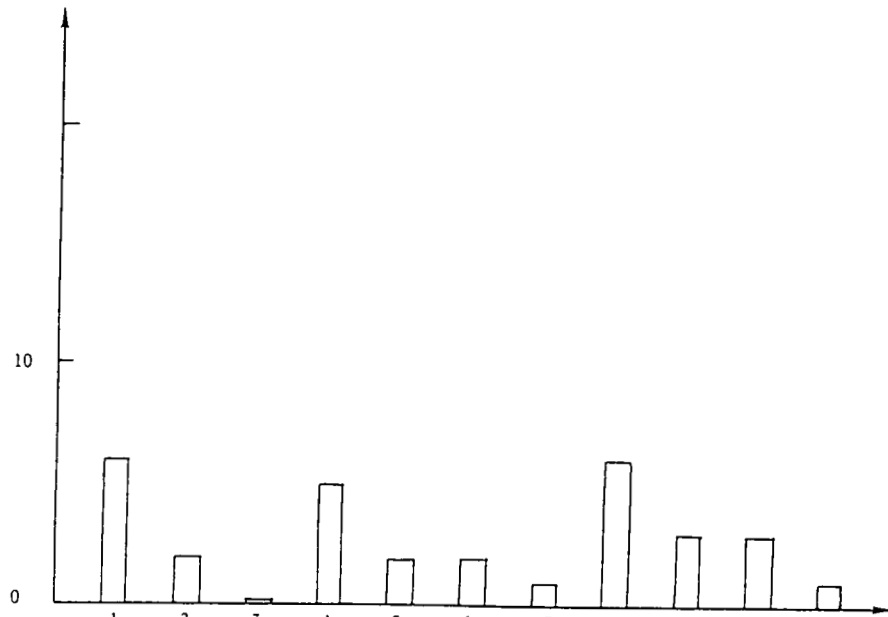

FIGURE 8

CLEANNESS OF 11 CONSECUTIVE POWDER BATCHES, DETERMINED BY ELUTRIATION OF THE 63-80 μm FRACTION

MAITRISE DE LA REPRODUCTIBILITE DU PROCEDE DE FORGEAGE

F. CHEVET
M. CARALP
FORGE SNECMA
USINE DE GENNEVILLIERS
291, Avenue d'Argenteuil
92200 GENNEVILLIERS
FRANCE

RESUME

Les propriétés des disques pour moteur d'avion en alliages base Titane et base Nickel, peuvent être notablement améliorées par le contrôle des déformations et des températures en cours de forgeage. Cette optimisation par des traitements thermomécaniques est utilisée de façon quasi systématique sur les moteurs les plus récents.

Pour répondre à cette exigence, SNECMA a mis en place une supervision de procédé dans ses Ateliers de Forge : des superviseurs, installés sur les outils de déformation à chaud, réalisent l'enregistrement et le traitement statistique des paramètres significatifs.

Ce nouveau suivi effectué en temps réel sur le process permet une détection immédiate des variations des fabrications et une correction rapide des déviations éventuelles.

La vérification de la reproductibilité des conditions de fabrication est devenue systématique et les méthodes d'assurance qualité du produit forgé, fortement dépendantes des conditions de transformation, ont ainsi progressé.

Enfin grâce à l'ensemble des connaissances ainsi acquises sur le procédé de forgeage, la maîtrise des traitements thermo-mécaniques s'est élargie. On a pu observer que des variations de paramètres, auparavant inaccessibles, avaient une influence déterminante sur la microstructure des pièces.

INTRODUCTION

Les disques des moteurs d'avion ont pour fonction de porter les aubes mobiles et de transmettre les puissances très importantes consommées (compresseur), ou fournies (turbine) par ces aubes.

Cependant, avant de remplir cette fonction mécanique, chaque disque doit d'abord retenir la force centrifuge due à sa propre masse. S'agissant de pièces destinées au transport aérien on comprend que ceci conduit à la recherche de la masse minimale. Pour le métallurgiste il en résulte une exigence de très hautes caractéristiques mécaniques.

Parallèlement les disques moteur présentent le niveau de sécurité le plus élevé car toute rupture en service mettrait en péril l'avion.

Cette association d'une recherche de caractéristiques optimisées au maximum et d'une garantie absolue du niveau de qualité confère à l'industrie du disque moteur une structure bien particulière.

C'est une des évolutions de ce métier que nous décrivons ci-dessous. Au delà de la mise au point des conditions de fabrication qui permette d'obtenir la qualité recherchée, il s'agit de vérifier à l'aide des "superviseurs" la réalité du respect des paramètres significatifs du procédé.

Cette démarche a rapidement dépassé le niveau de la stricte recherche de la conformité et permis de réaliser d'importants progrès dans la maîtrise de la qualité des pièces.

1. IMPORTANCE DES TRAITEMENTS THERMOMECHANIQUES

1.1 Amélioration des caractéristiques statistiques

Les disques moteur sont réalisés en matériau forgé base titane ou base nickel. Les caractéristiques de ces alliages ont soigneusement été optimisés par les élaborateurs. Cependant il est apparu des possibilités de les améliorer encore en contrôlant la microstructure au cours du forgeage réalisant ainsi un "traitement thermomécanique".

On trouvera figure 1 un exemple des niveaux minimaux requis pour un même alliage (Inconel 718), en fonction des grades de traitements thermomécaniques.

Entre le 718 standard et le 718 grain fin, la résistance augmente de 10%. L'Inco 718 DA (à vieillissement direct) permet de gagner 7% supplémentaires avec une microstructure encore plus fine et en conservant l'écroutissage résiduel de la dernière chaude.

1.2 Augmentation de la durée de vie en Forge

L'exemple précédent montre à quel point on peut améliorer le niveau de résistance d'un alliage par traitement thermomécanique. Mais l'affinement de la structure permet également une augmentation notable de la durée de vie en fatigue oligocyclique.

La figure 2 donne les résultats de fatigue obtenus dans différentes zones d'un disque de turbine en fonction de la microstructure. Dans les brides, la taille de grain plus grossière conduit à des durées de vie 7 fois moins élevées qu'au coeur de la pièce là où le grain est le plus fin.

Cet exemple est particulièrement démonstratif car les résultats proviennent de la même pièce. Il s'agit du même alliage, de la même coulée et du même traitement thermique. La cause de la variation énorme des résultats de fatigue est donc uniquement due à la différence des microstructures liées aux conditions de forgeage.

1.3 Utilisation des traitements thermomécaniques

Dans l'exemple ci-dessus, l'effet traitement thermomécanique est subi : les zones de brides moins déformées en dernière chaude ont une structure relativement grossière.

L'art du forgeron moteur, consiste à maîtriser les paramètres influents pour obtenir les structures désirées dans les différentes zones de la pièce où on le souhaite. Une adaptation correcte de la gamme de forgeage permet de réaliser la même pièce avec des microstructures uniformément fines telles que présentées sur la figure 3.

Ces exemples relatifs à l'Inconel 718 ne sont pas des cas isolés d'utilisation des traitements thermomécaniques. Ceux-ci représentent actuellement la règle quasi générale de la fabrication des disques moteur aussi bien pour les alliages base Nickel (718, Waspaloy...) que ceux base Titane (Ti 17, 6-2-4-2,...).

2. PARAMETRES A MAITRISER LORS DES TRAITEMENTS THERMO-MECHANIQUES

2.1 La température

La température (θ) est certainement le paramètre influant de façon la plus évidente sur le résultat final. La figure 4 montre l'évolution de la taille de grain de l'Inco 718 en fonction de la température. Si l'on veut obtenir une microstructure optimisée, le bon choix du temps et de la température de chauffage préalable au forgeage est primordial.

Le niveau de température joue également un rôle très important dans la cinétique des transformations métallurgiques (recristallisation, restauration...) pendant la déformation.

2.2 Le taux de déformation

Dire que, pour améliorer la structure par forgeage il faut contrôler le niveau de déformation est une évidence qu'il est inutile de démontrer ; par contre il faut bien avoir conscience

qu'il s'agit de déformations locales et que celles-ci varient d'un point de la pièce à l'autre.

Pour revenir à l'exemple de la figure 1, la modélisation par éléments finis (réf. 1) de la dernière chaude, montre que les structures grossières sont en relation avec des "zones mortes" peu déformées (figure 5).

Le contrôle de l'opération de forgeage suppose donc que l'on soit à même de déterminer ces déformations locales et d'en assurer la reproductibilité au cours de la fabrication industrielle.

Des études métallurgiques fines permettent de tracer des courbes telles que celles de la figure 6. Elles donnent l'évolution de la microstructure en fonction du taux de déformation (ϵ).

2.3 La vitesse de déformation

La recristallisation dynamique telle que celle qu'on a observée figure 6 dépend également de la vitesse ($\dot{\epsilon}$) avec laquelle la déformation a été appliquée. Il faut donc également en tenir compte lors du contrôle des opérations de forgeage.

2.4 L'échauffement adiabatique

L'énergie mécanique de la déformation se dissipe pour l'essentiel (plus de 90%) en chaleur. Ceci peut provoquer des échauffements relativement importants et donc des modifications de la microstructure. L'exemple le plus connu est le franchissement du transus Beta des alliages de Titane lors d'un forgeage trop rapide.

Dans ce cas aussi, la modélisation par éléments finis est un atout important pour la maîtrise de ces températures internes (figure 7).

2.5 Paramètres à maîtriser

On retiendra que la réalisation de traitements thermomécaniques nécessite le contrôle de :

- La température (θ)
- La déformation (ϵ)
- La vitesse de déformation ($\dot{\epsilon}$)
- L'échauffement adiabatique ($\Delta \theta$)

La sélection optimale de ces paramètres est du ressort du Bureau d'Etude Forge et des métallurgistes.

Mais l'assurance de la reproductibilité des fabrications est une préoccupation majeure à laquelle la Forge SNECMA répond par une stratégie de supervision du procédé de forgeage.

3. LA SUPERVISION EN FORGE

L'équipement des engins de la Forge SNECMA avec des superviseurs a été engagé depuis 1990. Un laminoir circulaire 500 T et une presse hydraulique 4000 T fonctionnent chacun avec un superviseur répondant aux caractéristiques spécifiques du procédé qu'ils mettent en oeuvre.

3.1 Matériel et Organisation

Sur le plan matériel l'implantation d'un superviseur sur un outil de Forge consiste à faire mesurer les principaux paramètres par un micro-ordinateur. Nous avons choisi un matériel relativement peu onéreux (compatible IBM industriel de la série 386).

La liaison avec les automates programmables des machines permet d'accéder à toutes les données d'effort ou de déplacement. Par ailleurs l'introduction des données relatives aux pièces n° de série, aux conditions de chauffage est faite par les opérateurs par l'intermédiaire d'un écran-clavier.

La figure 8 donne le schéma d'implantation d'une de ces installations. Actuellement les superviseurs sont installés sur deux postes de travail, mais à échéance de deux ans, tous les outils principaux en seront équipés.

3.2 Fonction du superviseur

Bien qu'ils s'adaptent aux spécificités de l'engin, les superviseurs répondent toujours à quatre fonctions principales :

1 - Les valeurs des paramètres spécifiques du procédé sont acquises à intervalles de temps réguliers et durant toute l'opération de forgeage;

2 - Les recettes de fabrication des différentes pièces produites peuvent être stockées et sont disponibles à tout instant au poste de travail.

3 - Une visualisation graphique d'évolution des paramètres du procédé, un synoptique d'état réel de la machine et d'autres outils d'aide au pilotage sont intégrés au superviseur.

4 - Le suivi régulier des paramètres du procédé permet un suivi statistique de la fabrication.

3.2.1 Acquisition des paramètres du procédé

Ces derniers sont de 2 types :

Les paramètres du procédé, dépendant ou non du temps, mesurés uniquement à un instant donné sont enregistrés sur un document de synthèse de la fabrication :

Ces données décrivent l'opération de forgeage et sont généralement peu liées au type d'outil. Elles sont enregistrées une fois par opération et sont reportées sur le document de synthèse de fabrication. Il s'agit essentiellement :

- . des temps de chauffe
- . des four utilisés
- . des temps de transferts avant forgeage
- . du temps total de déformation
- . des températures de défournement, début et fin de forgeage

Les paramètres spécifiques de l'outil de forgeage qui sont enregistrés en fonction du temps :

3 paramètres pour la presse hydraulique
(course, vitesse, effort).

9 paramètres pour le laminoir circulaire.

La figure 9 donne un exemple de document de fabrication édité suite à l'enregistrement de ces informations.

3.2.2 Gestion des recettes de fabrication

La recette de fabrication de pièce forgée comporte toutes les informations techniques géométriques, et thermiques nécessaires à un forgeage correct de la pièce. Ce document, intégré au superviseur peut-être consulté et géré de manière directe par l'opérateur.

Lorsque les automatismes le permettent un téléchargement à partir du superviseur fournit tous les réglages initiaux de la machine.

3.2.3 Visualisation de l'évolution des paramètres

Le superviseur ayant acquis toutes les informations sur l'opération de forgeage, il peut les restituer pour aider au pilotage de l'engin de forge. Deux types de restitution sont couramment effectués.

- un tableau synoptique de l'état de fonctionnement de la machine (voir figure 10)
- l'évolution en fonction du temps des paramètres significatifs (course, effort, vitesse...)

3.2.4 Suivi statistique des fabrications

Chaque opération de forgeage est synthétisée par un ensemble de paramètres globaux (8 à 15) qui caractérisent l'opération de déformation à chaud. Ceux-ci sont choisis de telle sorte qu'une variation quelconque du procédé affecte au moins l'un d'entre eux.

Les paramètres sont suivis par les procédés statistiques habituels (carte de contrôle) qui permettent de vérifier la reproductibilité du procédé.

4. VERIFICATION DE LA STABILITE DES CONDITIONS DE FORGEAGE

4.1 Vérification de la stabilité des conditions de forgeage

Le superviseur a accès à toutes les grandeurs caractéristiques de l'opération de fabrication. Il peut donc aisément détecter toutes les variations inhérentes à une quelconque activité humaine. Il remplit en ce domaine une fonction typique d'assurance qualité.

La figure 11 montre en superposition les évolutions de l'effort radial et du diamètre extérieur, en fonction du temps pour une succession de pièces laminées de la même série. La coïncidence des courbes est dans ce cas remarquable, indiquant qu'il y a une identité quasi parfaite de la transformation thermomécanique.

La figure 12 donne les mêmes informations pour une autre série de ce même type de pièce laminée à une autre date et par un autre opérateur. Les enregistrements obtenus sont différents des précédents. La supervision nous permet donc de constater les différences sensibles dans le mode d'utilisation de l'engin entre deux séries et deux opérations.

La supervision est donc un moyen efficace d'appréciation de la qualité et de la répétitivité d'une fabrication.

4.2 Suivi des paramètres de matriçage

Dans le cas du matriçage de pièces de très haute caractéristique (forgeage en matrices chaudes), le superviseur est utilisé de façon systématique pour vérifier la régularité des séquences de déformation. La figure 13 donne un exemple d'un des documents de dépouillement permettant de suivre les paramètres suivants :

- temps de transfert four ---> presse
- temps de forgeage
- temps de transfert presse ---> trempé
- température de la pièce avant et après matriçage
- température de l'outillage avant déformation

4.3 Détection d'une variation de température

Les superviseurs se sont révélés un moyen de détection très sensible des variations, mêmes tenues de température.

Le laminoir de 500 t est desservi par plusieurs fours et lors de séries suffisamment longues, un même type de pièce provient de l'un ou l'autre d'entre eux. Il s'agit de fours précis, réglés avec une tolérance de $\pm 10^{\circ}\text{C}$, mais tout en respectant cette tolérance, on peut observer des écarts entre 2 fours.

Le superviseur a permis de mettre en évidence ce type de petites variations. A effort de laminage constant les pièces issues du four A sont terminées plus rapidement que celles provenant du four B.

Il s'agit dans ce cas de variations minimales à l'intérieur des fourchettes admises pour la fabrication, mais les superviseurs devraient se révéler des outils extrêmement puissants pour se prémunir des dérives de température.

4.4 Suivi dimensionnel

Une des grandes ambitions de l'industrie de la Forge est de réduire la masse de métal engagée en réalisant un forgeage près des cotes.

La supervision de procédé apporte un suivi dimensionnel à chaud très utile à l'amélioration des performances. La figure 14 donne l'histogramme des diamètres extérieurs obtenus au cours du laminage d'une série de pièces. Nous avons pu vérifier ainsi l'excellente capacité du procédé pour obtenir des précisions de l'ordre du millimètre.

5 AMELIORATION DE LA CONNAISSANCE DU PROCEDE

Grâce aux superviseurs, des paramètres du procédé auparavant inaccessibles, sont suivis de manière systématique et leur évolution pour chaque type de pièce peut être analysée. La connaissance du procédé de forgeage s'élargit ainsi progressivement et la maîtrise des qualités métallurgiques de du produit devient plus efficace.

5.1. Traitement des données du procédé de laminage

La qualité métallurgique des disques et autres pièces forgées constituant un moteur d'avion est contrôlée à l'issu du cycle de forgeage.

Un examen de l'aspect micrographique et une analyse des caractéristiques mécaniques des pièces produites est réalisée à une fréquence qui dépend de l'importance fonctionnelle des pièces dans le moteur.

Malgré une optimisation continue, ce type de suivi est onéreux. Une appréciation de la qualité métallurgique des pièces pendant le déroulement du process permettrait de réduire le coût du suivi du produit et d'apprécier plus rapidement la qualité de nos fabrications.

Pour atteindre cet objectif, la détermination précise des relations qui existent entre les paramètres du procédé et les résultats sur le produit correspondant est indispensable. C'est dans ce cadre que nous analysons les données du procédé enregistrées .

Avant d'être corrélées, avec les résultats métallurgiques, les données précédentes doivent subir un traitement spécifique. Une ou plusieurs valeurs seulement résumant objectivement les variations du paramètre intervenues au cours du forgeage sont déterminées et conservées.

Ce traitement est réalisé à l'issue de l'opération de forgeage grâce à des outils micro-informatiques simples.

Ainsi, à partir de l'effort radial au cours du laminage, on calcule le temps de déformation, le temps d'application de l'effort maximum, l'effort moyen appliqué sur la pièce et l'énergie totale de déformation.

5.2 Cas du laminage d'une couronne simple en INCONEL 718

L'effort radial est le paramètre important du process de laminage puisqu'il détermine la déformation subie par la pièce et l'échauffement adiabatique.

L'influence de ce paramètre sur la microstructure d'une couronne simple en Inconel 718 laminée a été étudiée sur un lot de 4 pièces issues d'une même billette de matière , forgées à une date identique par le même opérateur.

5.2.1 Modification des paramètres de laminage

L'objectif que l'on s'était fixé était de laminar la même pièce en faisant varier l'effort de laminage de 165 à 215 T.

L'enregistrement des paramètres (figure 15) montre qu'un effort plus élevé conduit à une vitesse d'accroissement du diamètre plus grande et à un temps de laminage plus court. Entre les valeurs extrêmes d'effort le temps total est divisé par deux (52 à 26 secondes).

Corrélativement, les pièces forgées sous un effort important terminent la déformation à une température plus élevée sous l'action conjuguée :

- de l'échauffement adiabatique plus important
- temps de laminage plus court

Ce point est confirmé par les mesures de température en fin de déformation.

5.2.2 Observations micrographiques

La figure 16 montre que les microstructures obtenues sur pièces sont sensiblement différentes en fonction des conditions de forgeage.

- 165 tonnes ---> grain assez grossier
4 ASTM écroui
- 180 tonnes ---> grain partiellement
recristallisé
5 ASTM écroui + 9 ASTM
- 215 tonnes ---> structure totalement recristallisée
grain 8-9 ASTM

5.2.3 Interprétation métallurgique

Ce résultat est métallurgiquement logique. Il correspond à une loi quasi-générale et bien connue sur l'Inconel 718 : la recristallisation est favorisée par une température élevée (ref. 2)..

La pièce laminée avec 165 tonnes a été déformée trop froide pour pouvoir recristalliser. On observe le grain initial écroui.

Celle réalisée sous 215 tonnes a pu recristalliser totalement grâce au niveau de température plus élevé.

Les pièces laminées sous un effort intermédiaire présentent une recristallisation partielle.

5.2.4 Conclusions

L'exemple ci-dessus est très démonstratif parce que la variations des paramètres n'est pas excessive ou anormale. Il s'agit de conditions qui respectent les règles habituelles du métier.

La pièce sur laquelle ont été faits ces essais, ne présente pas de niveau de spécification sévère. Toutes les microstructures obtenues sont potentiellement capables des caractéristiques mécaniques requises.

Mais pour atteindre des niveaux de spécification élevés, l'application du savoir-faire courant n'est plus suffisant. La supervision de procédé est à la fois le moyen d'apprendre comment réaliser des pièces très optimisées et la possibilité de fiabiliser leur fabrication.

6. SUPERVISION DE PROCEDE ASSOCIEE A LA MODELISATION

Au cours des dix dernières années, l'industrie de la forge a fait des progrès remarquables grâce au développement de la modélisation par éléments finis (réf. 1). Ces méthodes sont extrêmement performantes puisqu'elles donnent accès à la connaissance des déformations et des températures internes ainsi qu'aux contraintes locales en cours de forgeage. Par contre, l'application de la modélisation est en partie freinée par les difficultés de vérifications expérimentales sur les outils industriels. Il y a bien eu des travaux de

sur des presses expérimentales, mais il s'agit souvent de pièces de petite taille et d'un nombre réduit d'essais.

La supervision est l'occasion d'acquérir une quantité significative de résultats dans des conditions satisfaisantes :

- 1° - L'acquisition est complète parce que les conditions expérimentales telles que les temps de chauffage et de transfert sont enregistrés.
- 2° - La répétabilité de la mesure est assurée grâce à l'observation d'un grand nombre de cas.
- 3° - Il peut s'agir de pièces de toutes sortes et de toutes dimensions.

La figure 17 montre la corrélation obtenue entre l'effort de forgeage mesuré et la prévision faite par le logiciel FORGE 2

Le résultat est tout à fait satisfaisant mais pour aboutir à cette vérification, il est nécessaire de disposer de toutes les données :

- 1° - Il faut prendre en compte le refroidissement pendant le temps de transfert four-presses pour accéder à la température réelle du matériau.
- 2° - Le forgeage réalisé théoriquement à vitesse constante comporte un ralentissement lorsque l'on approche de l'effort maximal. Celui-ci étant mesuré par le superviseur il est possible d'en tenir compte lors du calcul. La figure 17 montre que cette correction de vitesse est importante pour vérifier la bonne corrélation.

On voit à travers cet exemple très simple l'importance de ce que va apporter la supervision pour étalonner les techniques de modélisation du forgeage.

CONCLUSION

Une stratégie de supervision des procédés de forgeage a été définie par la Forge SNECMA et entre actuellement en application industrielle.

Les premiers résultats sont très encourageants. Les objectifs initiaux ayant été atteints, les superviseurs se révèlent en effet capables de détecter des variations même ténues des conditions de fabrications.

La mise en place de ce système de suivi de procédé entraîne dès à présent des progrès plus importants. La connaissance très fine des conditions de forgeage permet un approfondissement très prometteur des techniques de contrôle de la microstructure.

1. Logiciel de calcul Forge 2 réalisé par le CEMEF et diffusé par TRANSVALOR
CEMEF 06565 SOPHIANIPOLIS FRANCE
2. Thèse de M. CAMUS
Traitements Thermomécaniques
de l'alliage NC19 Fe Nb
Oct. 86.
Ecole Nationale de Chimie de Toulouse

INCONEL 718
SPECIFICATION DE CARACTERISTIQUES MECANQUES
EN FONCTION DU TRAITEMENT THERMOMECHANIQUE
(Essai de traction à 650°C)

SPECIFICATIONS	TAILLE DE GRAIN (A.S.T.M.)	Rp 0.2% (MPa)	Rm (MPa)	A 5d (%)	Z (%)
718 P.Q.	4 ou plus fin	865	1005	12	20
718 SUPER.	8 ou plus fin	931	1100	12	20
718 DIRECT-AGED (Trempe directe) (après forgeage)	10 ou plus fin (écroui)	1103	1172	12	20

Figure 1

Figure 2

INFLUENCE DE LA MICCROSTRUCTURE SUR LES CARACTERISTIQUES DE FATIGUE OLICYCLIQUE

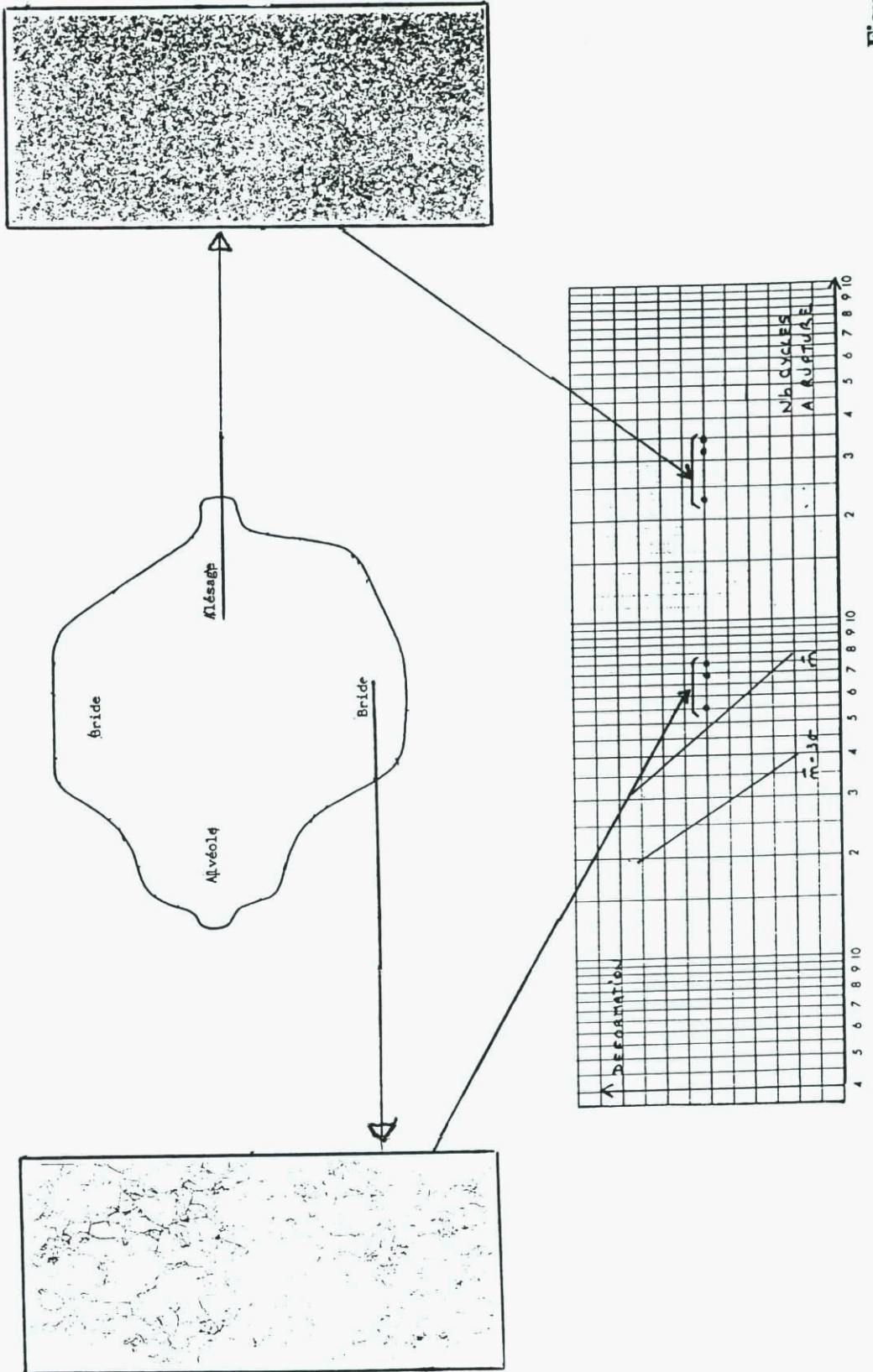

**ADAPTATION DU TRAITEMENT THERMOMECHANIQUE
POUR OBTENIR UNE MICROSTRUCTURE
UNIFORMEMENT FINE**

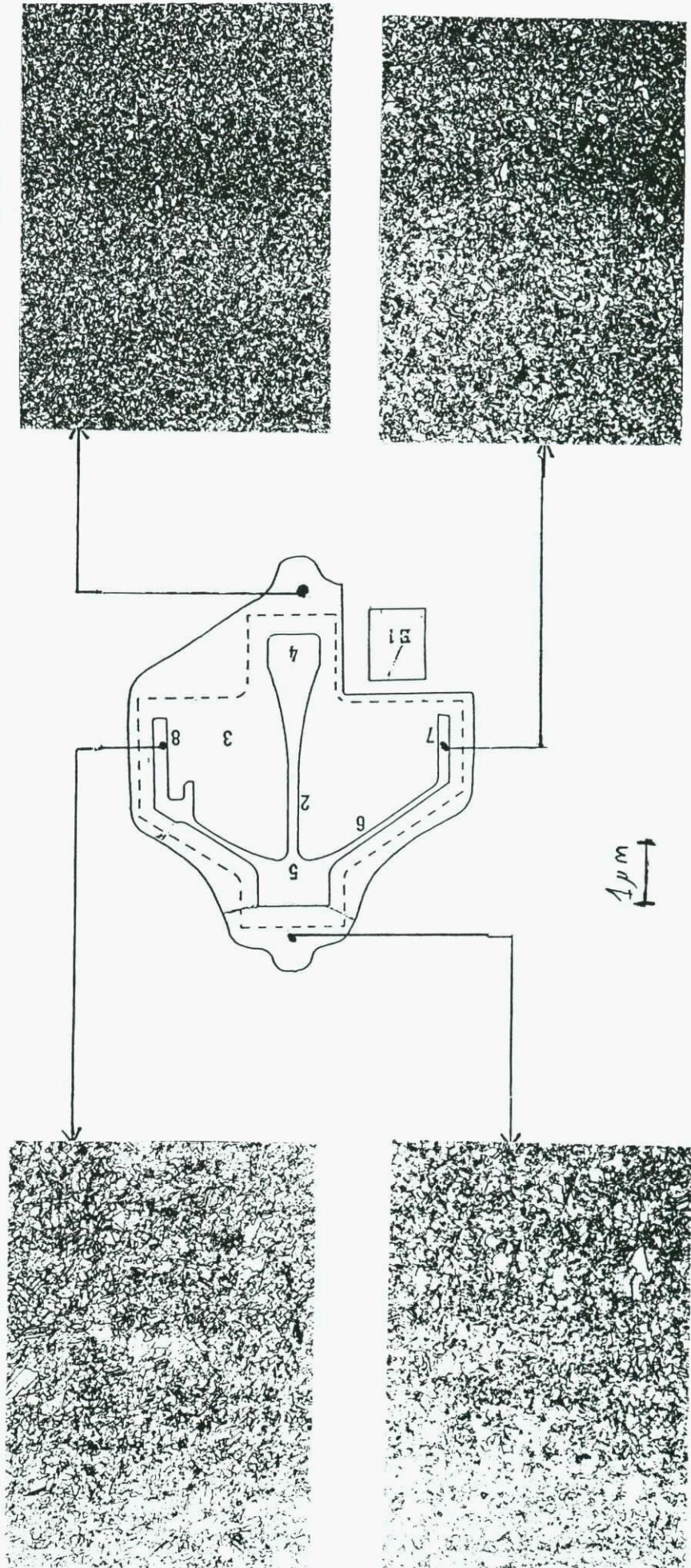

Figure 3

EVOLUTION DE LA TAILLE DE GRAIN DE L'INCONEL 718 EN FONCTION DE LA TEMPERATURE

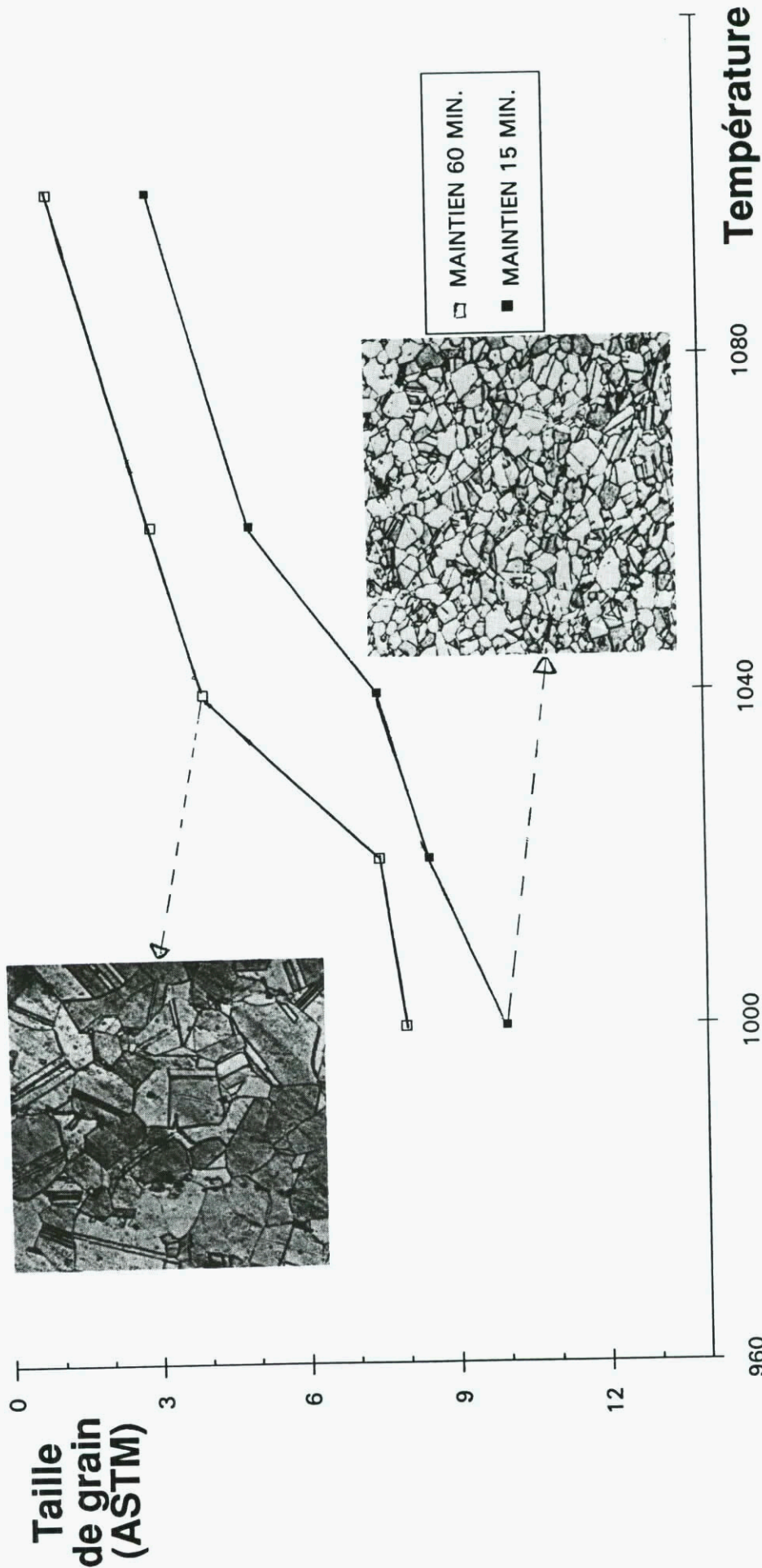
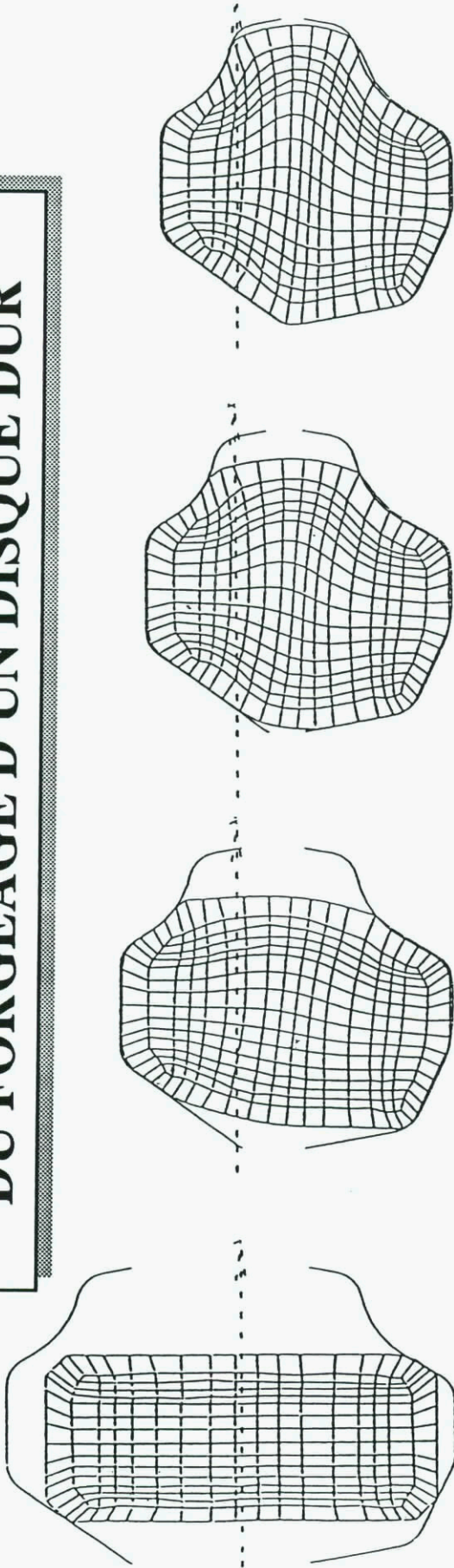

Figure 4

MODELISATION PAR ELEMENTS FINIS DU FORGEAGE D'UN DISQUE DUR



COURBES D'ISODEFORMATION

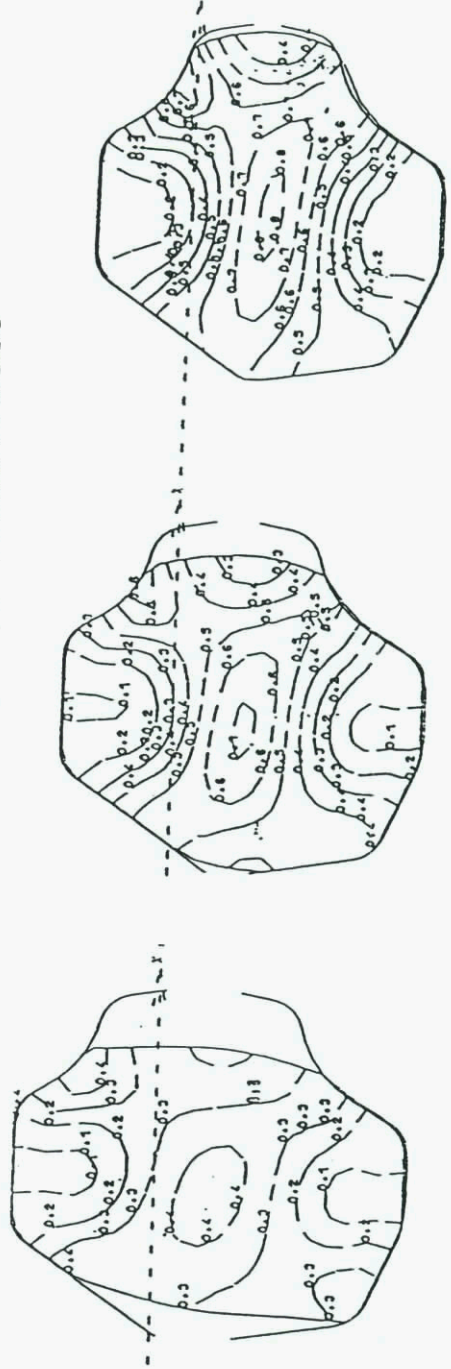

Figure 5

INCONEL 718
INFLUENCE DU TAUX DE DEFORMATION (ϵ)
SUR LA MICROSTRUCTURE
(Dépouillement d'un essai de torsion)

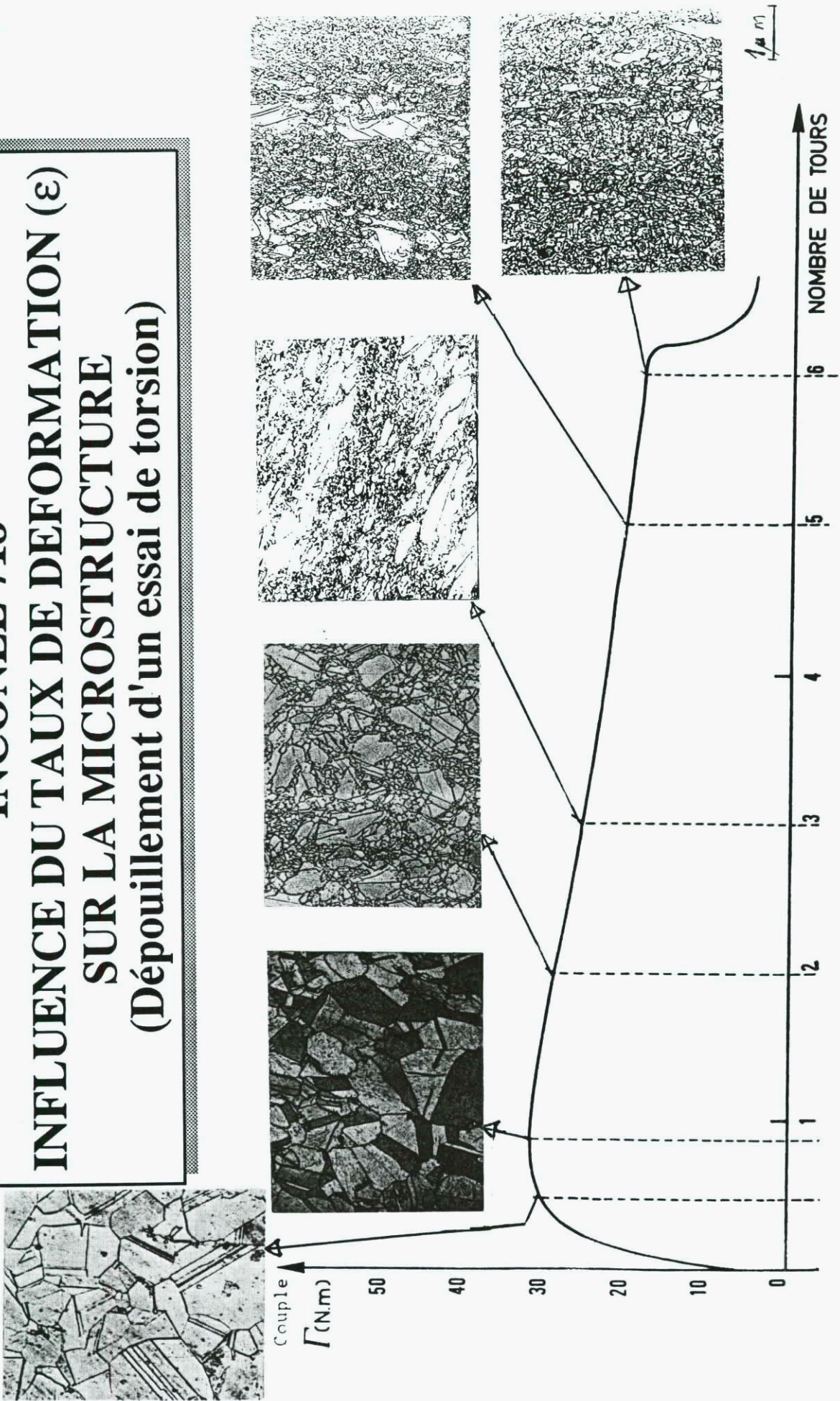

Figure 6

INFLUENCE DE LA VITESSE DE FORGEAGE SUR L'ECHAUFFEMENT ADIABATIQUE

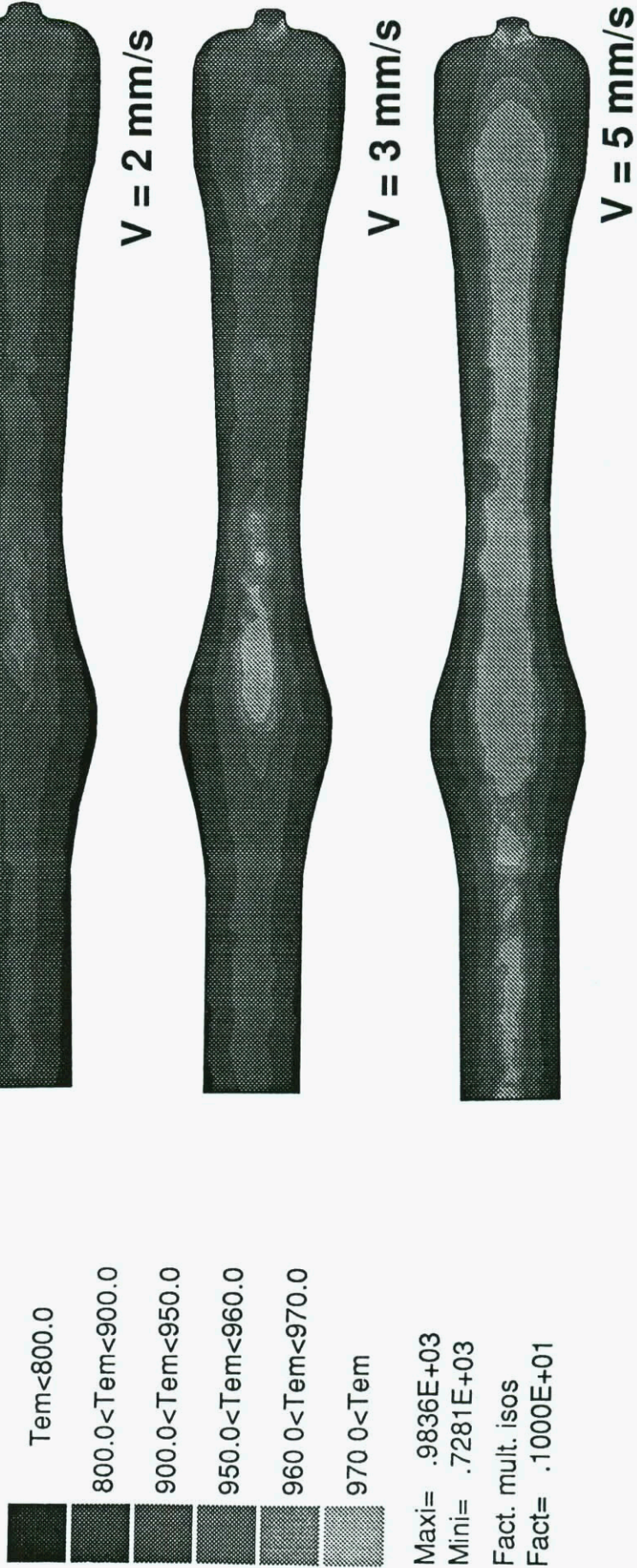
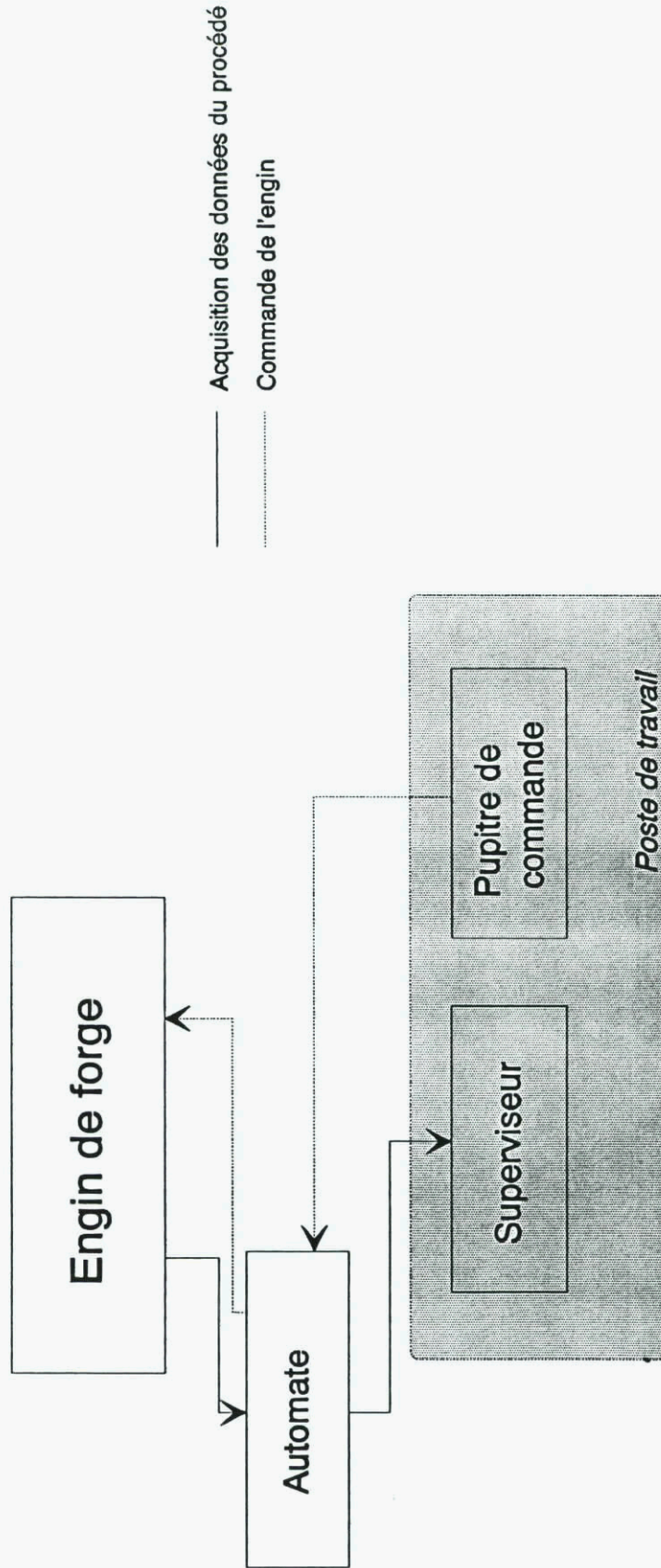

Figure 7

SCHEMA D'IMPLANTATION D'UN SUPERVISEUR SUR UN ENGIN DE FORGE



EXEMPLE DE RELEVÉ DE FABRICATION

LAMINOIR 500 Tonnes

Feuille de Température du : 1/3/92

N° Pièce:	XXX-XXX-XXX	N° OP:	270	N° Série:	SSSS	N° Lot	LLLLLLL					
Nom:	Pièce moteur		Matière:	MMMMM		Chauffe:	###°					
Lamineur:	Hédouin		Surveillant de température			Hamonet						
PRECHAUFFE	Température:	###°	Heure début:	###	Four:	38G						
Repère pièce	F.	H. Enf	T° Déf	H. Déf	T° déb	T° fin	Tp C	Tp T	Tp L	D ext	Haut.	D int
j184273	37g	17:53	1031	18:28	979	961	35	25.4	0.94	674.9	202.7	450.6
j184274	37g	17:55	1029	18:30	973	963	35	23.7	0.81	674.5	203.9	443.2
j184275	37g	17:57	1028	18:32	973	969	35	22.3	0.92	676.5	205.8	447.5
j184276	37g	17:59	1028	18:34	969	960	35	18.5	0.8	675	205.8	447.6

TABLEAU SYNOPTIQUE DE L'ETAT DE FONCTIONNEMENT DE LA PRESSE DE 4000 T

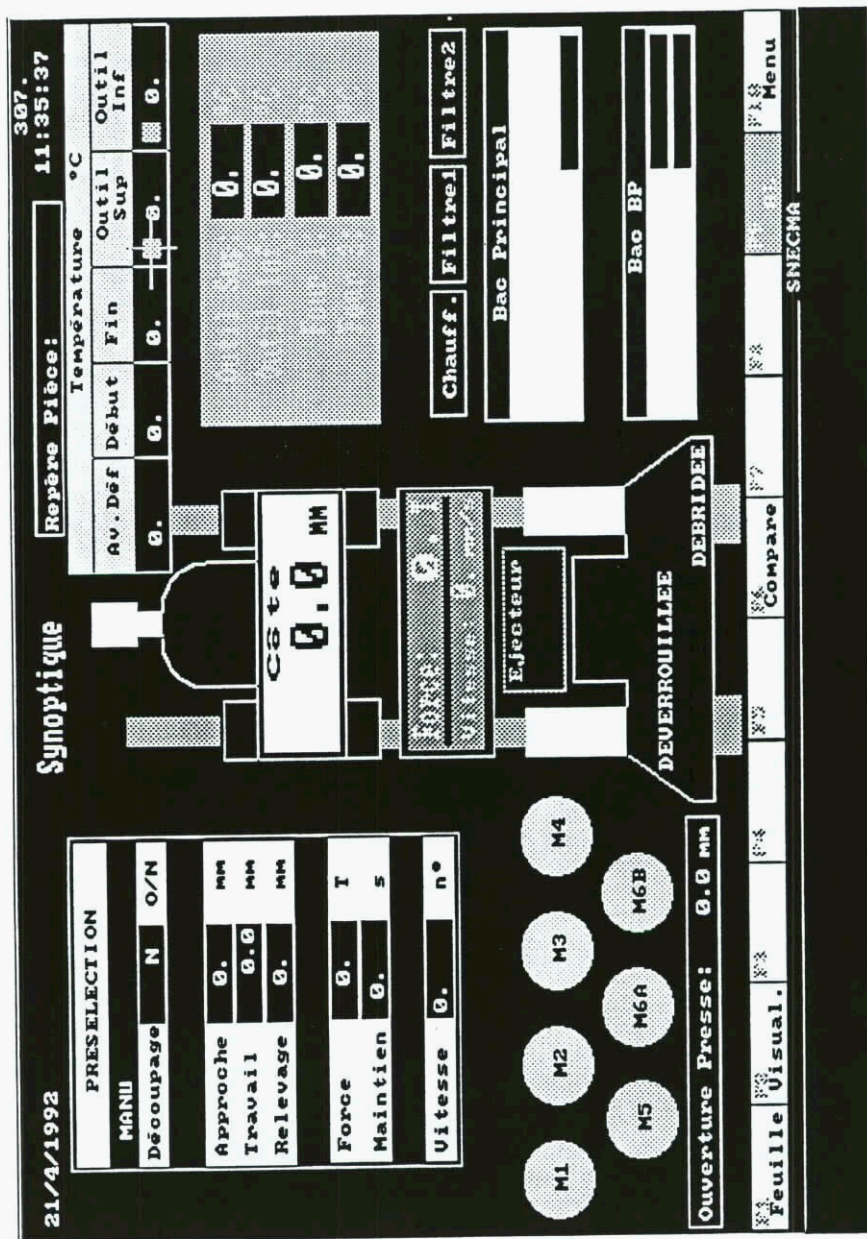

Figure 10

**VARIATIONS DE L'EFFORT RADIAL ET DU DIAMETRE EXTERIEUR
EN FONCTION DU TEMPS POUR UNE SERIE DE PIECES LAMINEES :
REPETITIVITE DES VARIATIONS AU SEIN DE LA SERIE**

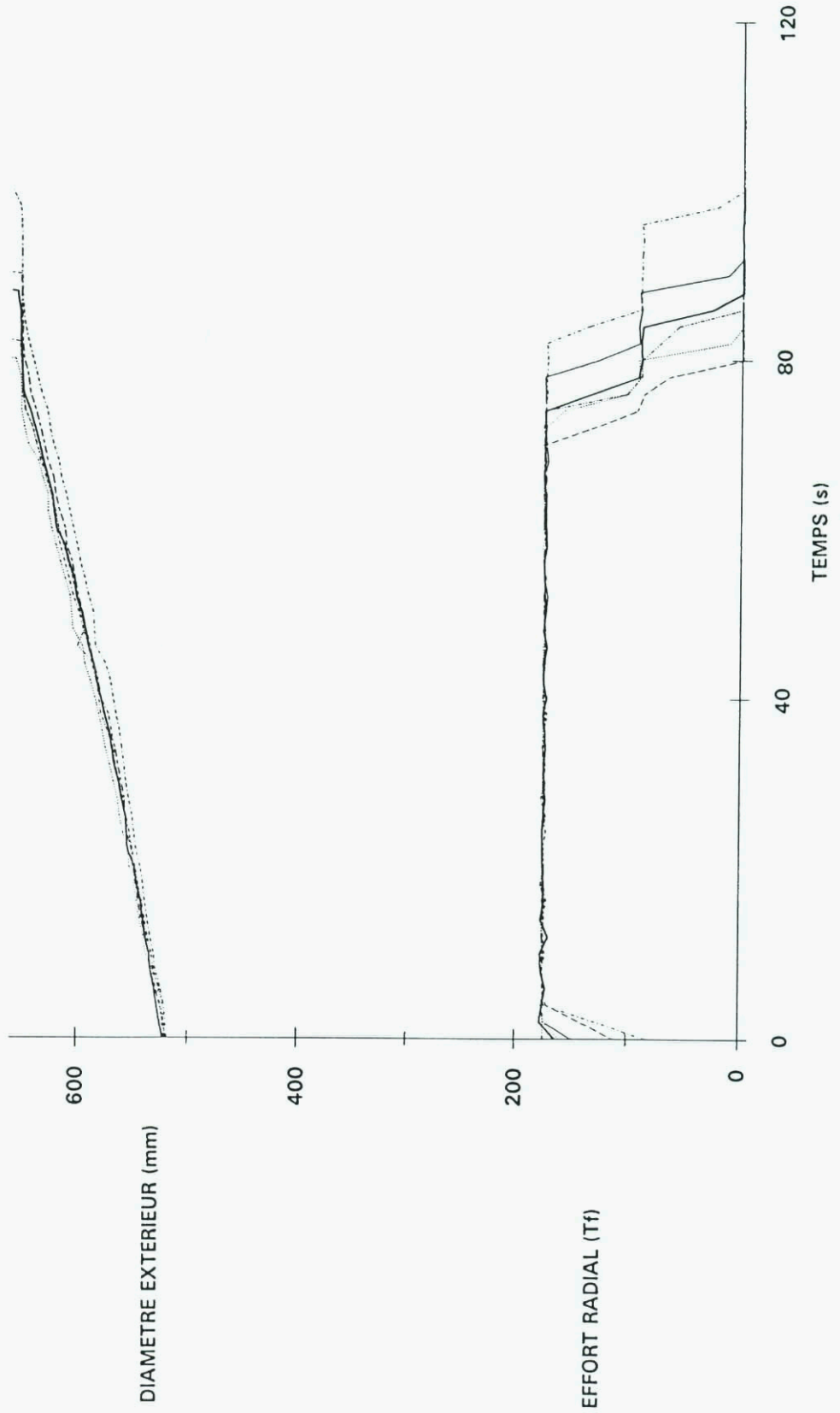

Figure 11

**VARIATION DE L'EFFORT RADIAL ET DU DIAMETRE EXTERIEUR
EN FONCTION DU TEMPS POUR UNE SERIE DE PIECES LAMINEES :
IRREGULARITE DES VARIATIONS AU SEIN DE LA SERIE
ET EXEMPLE DE NON REPETITIVITE ENTRE 2 SERIES**

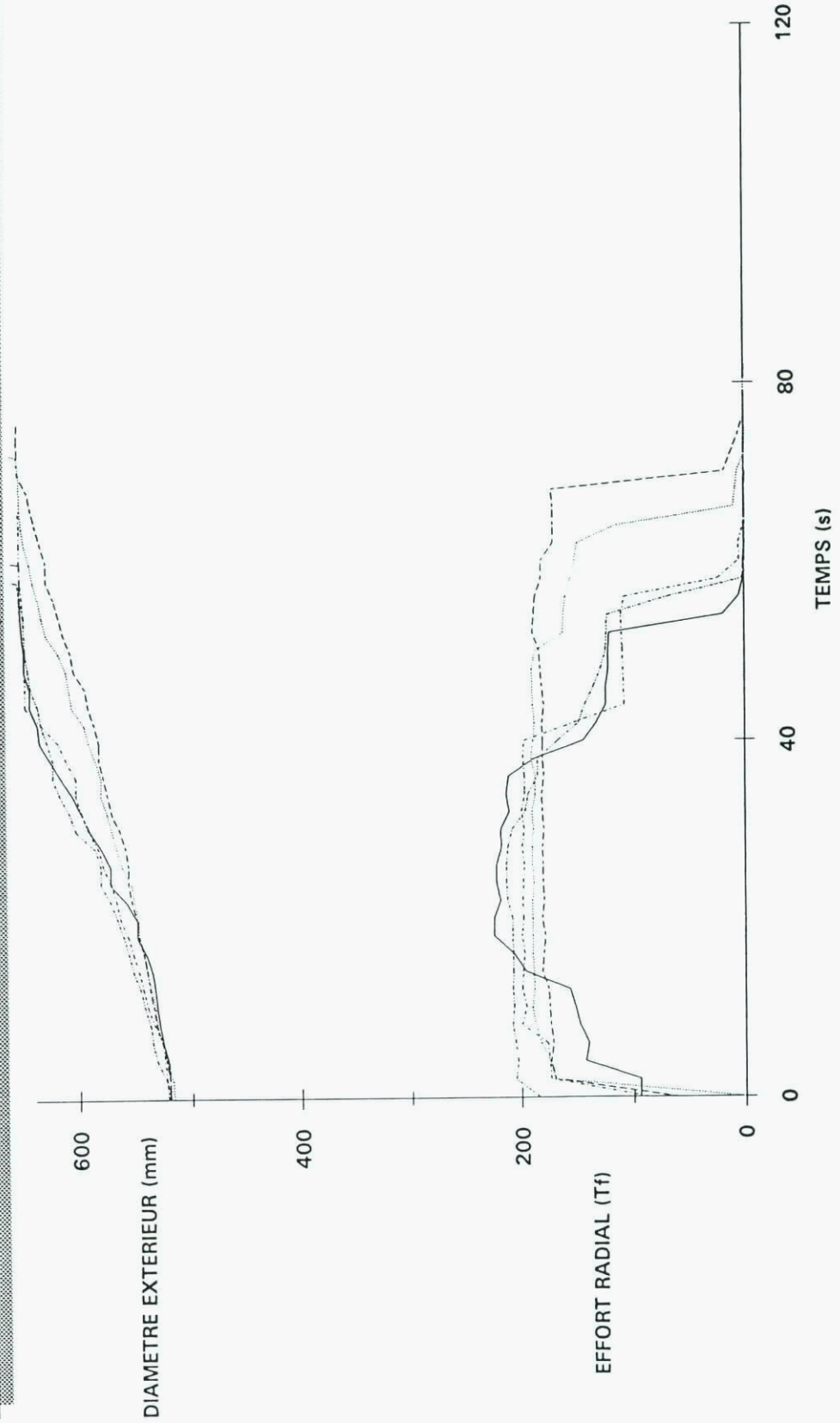

Figure 12

SUIVI DE REPETITIVITE D'UNE OPERATION DE MATRICAGE

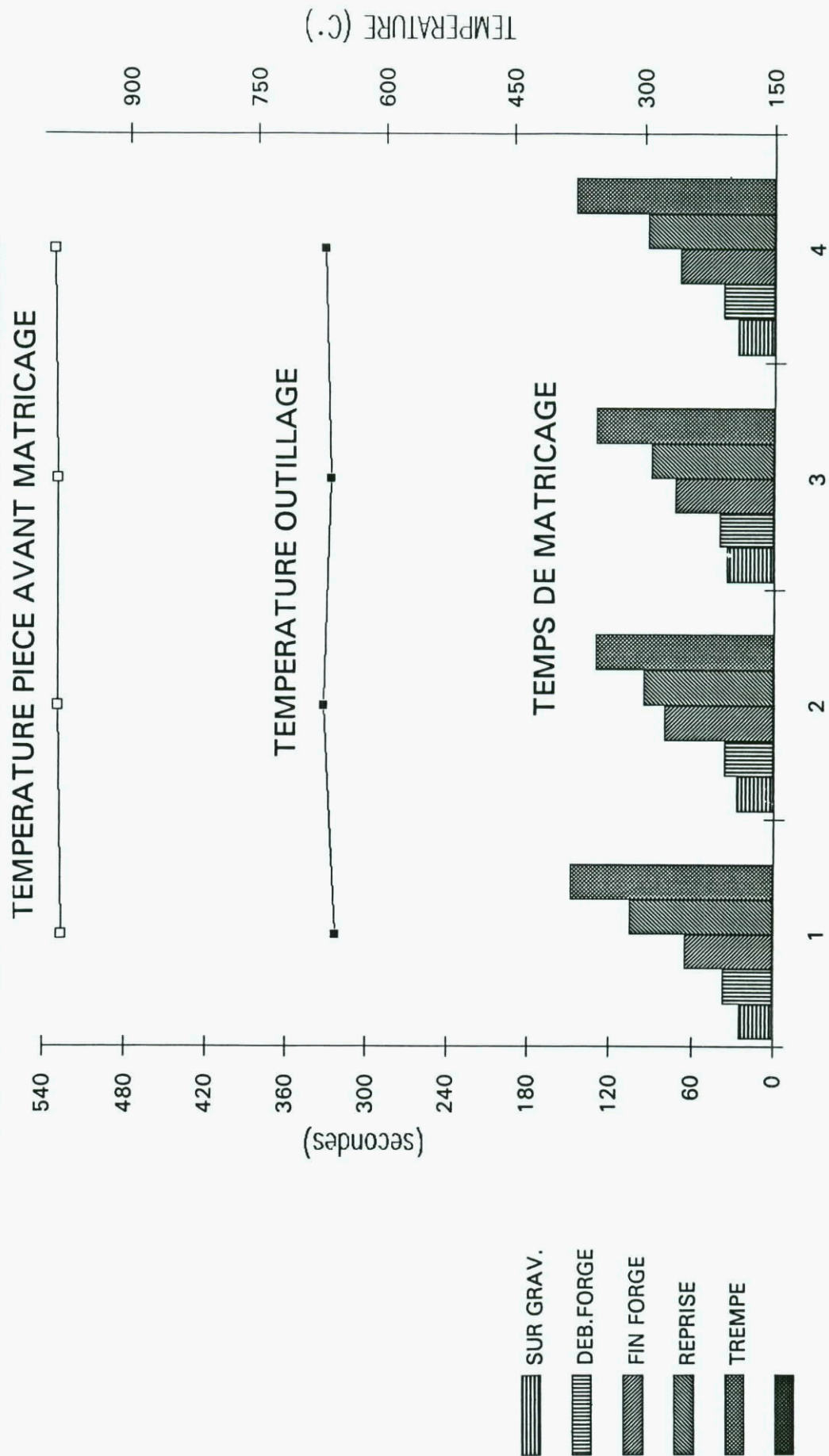

Figure 13

HISTOGRAMME DES DIAMETRES EXTERIEURS DE COURONNES LAMINEES CIRCULAIRES

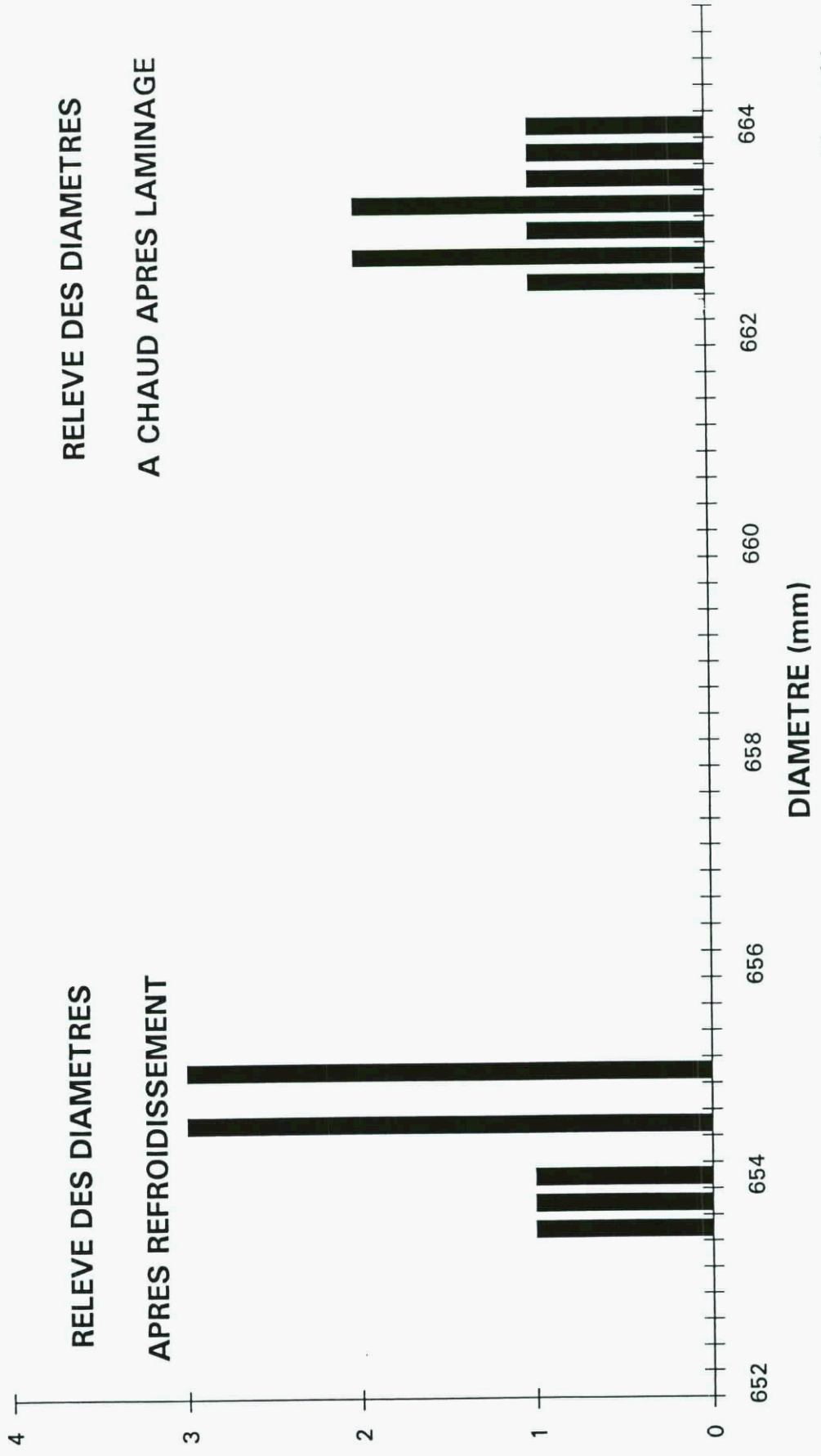

Figure 14

**ETUDE DE LAMINAGE D'UNE COURONNE SIMPLE EN INCONEL 718 :
 VARIATION DE L'EFFORT RADIAL ET DU DIAMETRE
 EXTERIEUR EN FONCTION DU TEMPS
 POUR LES 4 PIECES ETUDIEES**

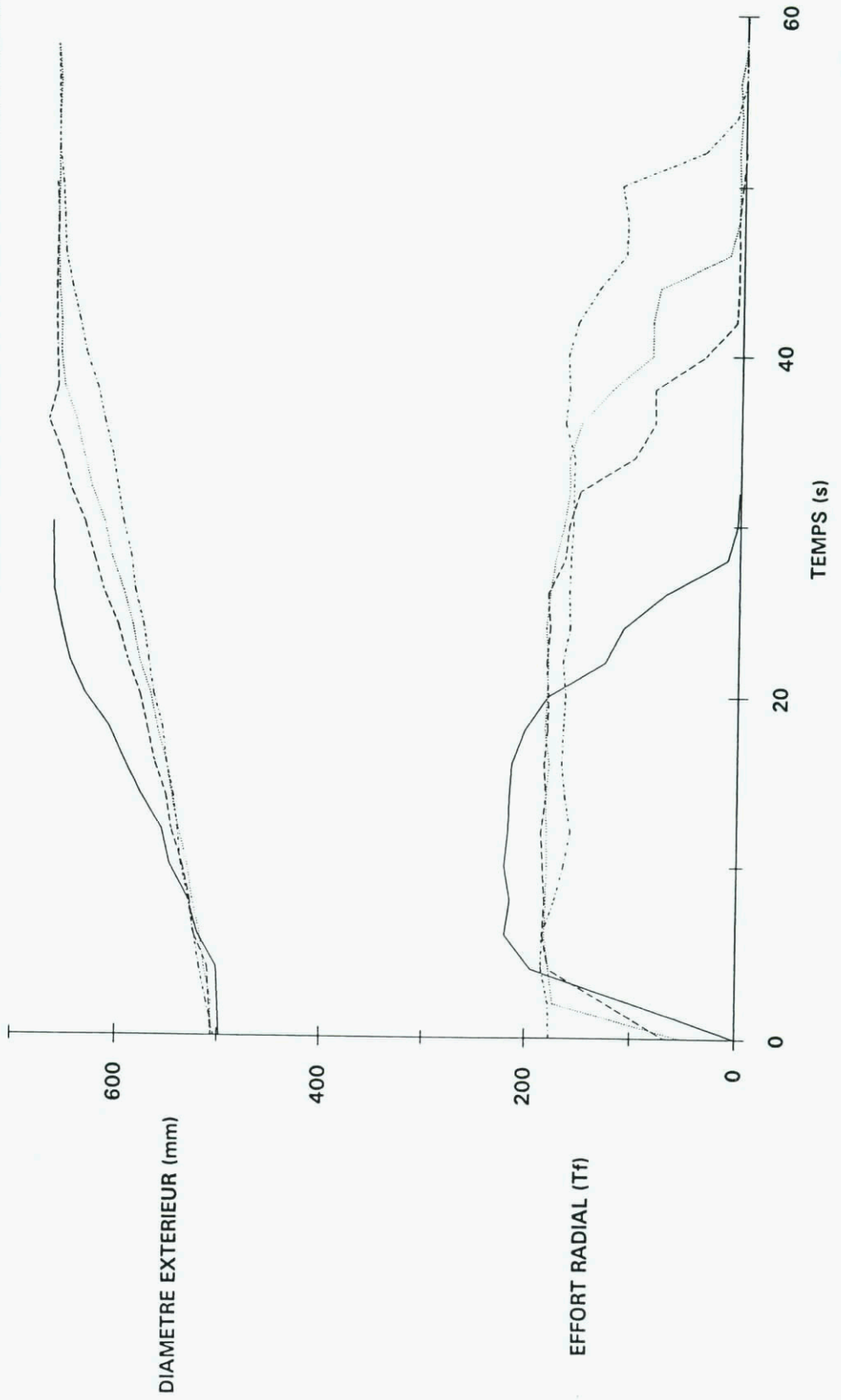
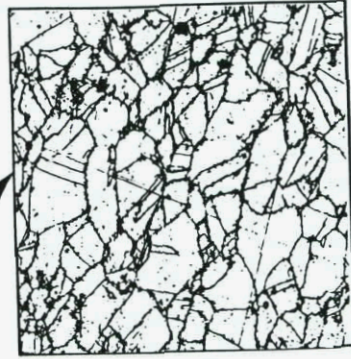

Figure 15

**ETUDE DU LAMINAGE D'UNE COURONNE SIMPLE
 EN INCONEL 718 : STRUCTURES MICROGRAPHIQUES
 ET PARAMETRES DU PROCEDE DES 4 PIECES ETUDIEES**

Effort radial moyen / Tf	215	182	179	165
Temps d'application de l'effort moyen / s	12	22	28	36
Temps de laminage / s	26	40	44	52
Température fin de laminage / °C	926	916	909	900



4 ASTM écroui

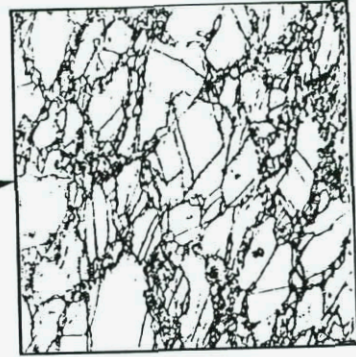

5 ASTM écroui + 9 ASTM

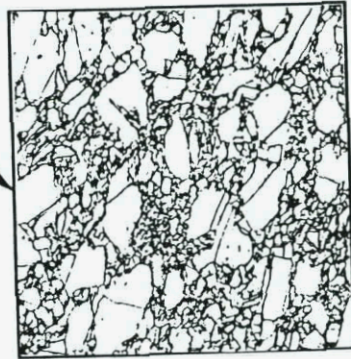

5 ASTM écroui + 9 ASTM

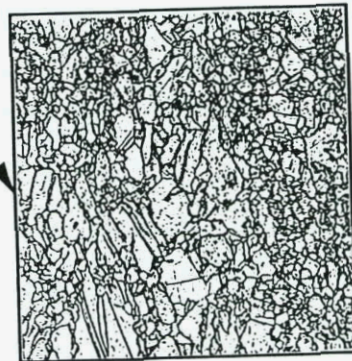

8-9 ASTM recristallisé

Figure 16

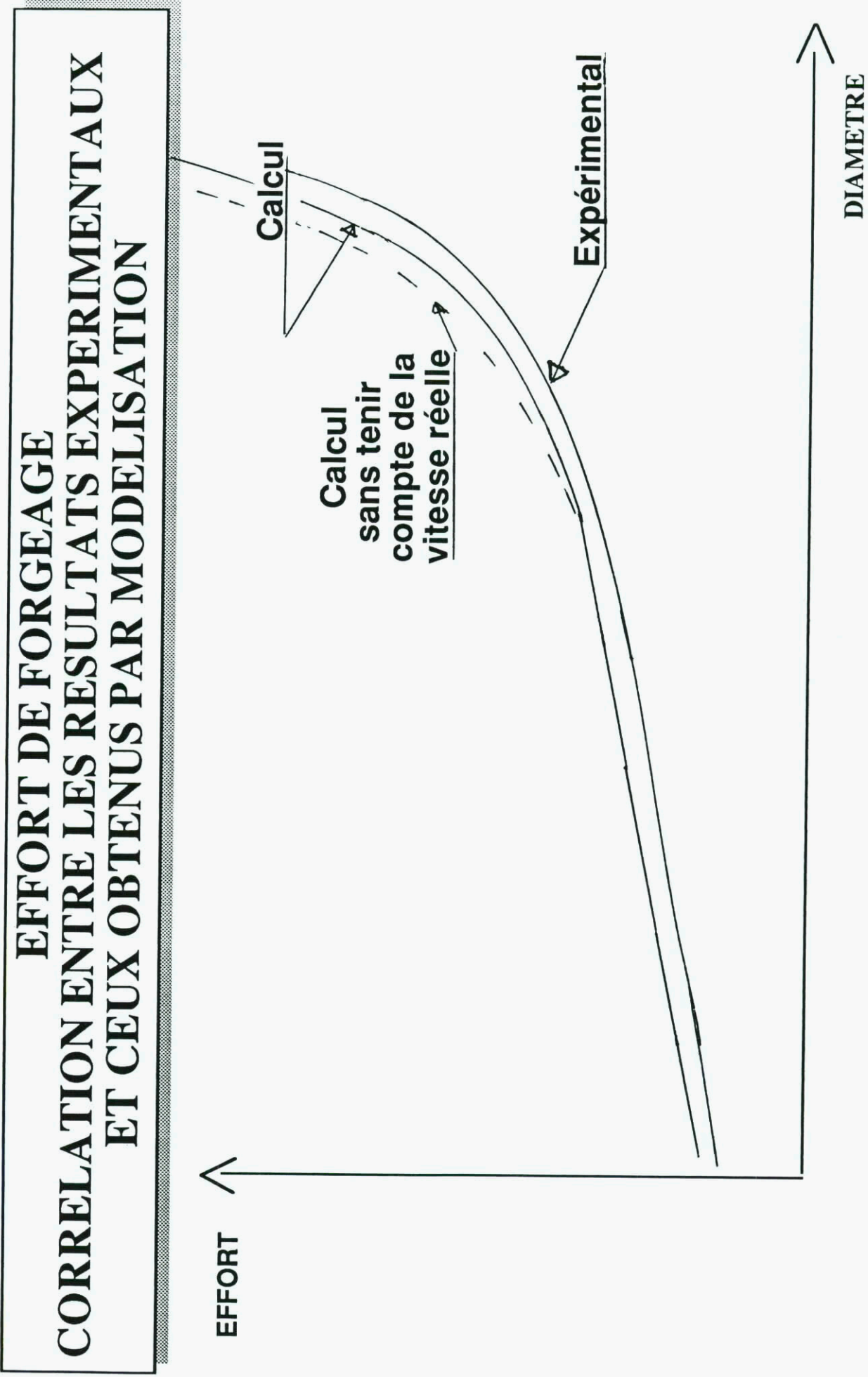

Figure 17

STATISTICAL CHARACTERIZATION OF RARE EVENTS

by

Charles Annis
Pratt & Whitney

Sharon Vukelich, USAF
ASD/ENFSF
Wright-Patterson AFB
OH 45433-6533
United States

Abstract

Inexpensive computing power has made computer-intensive methods, such as Monte Carlo simulation, available to a wide range of engineering problems, including risk assessments for structural components. Because well-designed structures have low probabilities of failure during their service lifetimes, it has become increasingly helpful to simulate the behavior of these unlikely events, so as to quantify the risk of failure.

This paper considers the behavior of the "tails" of the statistical distributions chosen to describe the behavior of life-controlling variables and their influence on the estimation of aggregate risk. It may seem obvious that the form of the probability distributions will necessarily have a profound influence on the resulting estimated probabilities of failure. What is perhaps less obvious are the subtle differences among candidate distributions in the range where most defining data will necessarily be obtained, namely between their fifth and ninety-fifth percentiles. We examine and compare several commonly used distributions: normal, log-normal, 2- and 3-parameter Weibull, and Beta.

Also considered here is the often used, but less often understood, concept of confidence associated with a probability of failure. Because it relies on knowing which one of several potential underlying probability distributions actually governs the observed behavior, it can result in a meaningless estimate of "confidence", and thus presents the potential for a false sense of security.

Introduction

The behavior of the "tails" of the statistical distributions chosen to describe the behavior of life-controlling variables has a profound influence on the estimation of aggregate risk. It may seem obvious that the form of the probability distributions will necessarily influence the probabilities of failure estimated from them. What is perhaps less obvious are the subtle differences among candidate distributions in the range where most defining data will necessarily be obtained, namely between their fifth and ninety-fifth percentiles. Thus, statistical tools correctly chosen and applied can still result in erroneous estimates of risk because the implicit assumptions on which they are based go unobserved. Several distributions commonly used in engineering risk assessment are examined and compared to illustrate this point.

Probability Distributions

A probability distribution describes the relative probabilities of two or more experimental outcomes, x_1, x_2, \dots , and its plot resembles a histogram when x is discrete. When x is continuous $P(x)$ vs x appears for example, as the familiar bell-shaped curve for the normal, or Gaussian, distribution as shown in Figure 1. This probability density is then used to estimate the probability that the distributed parameter takes on a value less than or equal to some predetermined limit. For example, in structural life assessment the distributed parameter might be cycles-to-failure and the limit of interest might be the 1/1000 quantile. In other words, we wish to determine the cyclic life with no more than one chance in a thousand of premature failure. (The specific quantile is determined by the particular problem under consideration; one-per-thousand is used here as an illustration.)

Now, if the underlying distribution were known with certainty then determining the 1/1000 cyclic life would be straightforward. In real circumstances, however, the underlying distribution is NOT known and several alternative models seem equally capable of describing the (limited) data available. While these distributions share the common trait of being unimodal (having a single "hump") and modeling the data over the range of observations, they exhibit widely differing behavior in their "tails", those quantiles quite removed from the center of the distribution.

Probability densities are referred to as either a "probability density function," pdf, or as its integral from left to right, the "cumulative distribution function," cdf. By convention the pdf is written to as $f(x)$, and the cumulative distribution function as $F(x)$. The cdf is used to determine quantiles of interest.

There are three measures of central tendency, the grouping of values near the population's center. These are the mean, the median, and the mode. The mean is the most familiar and represents the population's first moment or center of gravity. If the probability density were placed on a fulcrum, it would be balanced at the population mean. The mode is the most frequent observation and thus appears as the population's hump. The median is the value which is greater than half the population, and smaller than the other half. It is the 50th percentile. For symmetric distributions, these three fall atop one another.

What follows is a review of several probability distributions commonly employed in modeling component lifetime behavior. After a brief discussion of each, we will compare the behavior of their extremes ("tails").

The Normal Distribution

Perhaps the most familiar distribution because it occurs so often in nature is the normal, studied 200 years ago by Karl Gauss and for whom it is sometimes named. It is presented as Equation 1.

$$f(x) = \frac{1}{\sigma\sqrt{2\pi}} e^{-\frac{1}{2}\left(\frac{x-\mu}{\sigma}\right)^2} \quad [1]$$

The model parameter¹ μ is the population mean and locates the center of the distribution. The standard deviation, σ , describes the population dispersion and locates the point where the normal population distribution function changes from concave to convex.

The Log-Normal Distribution

Fatigue lifetimes are lognormally distributed. In nature it often occurs that the logarithm of a trait (such as cyclic capability) has a normal distribution, rather than the trait itself. Twenty years' experience in analyzing fatigue behavior indicates that the lognormal distribution provides a good model for observed behavior. As with many things in statistics, it is impossible to prove that something is true, only that the preponderance of data support that conclusion. Statistical goodness-of-fit tests can be used to gauge the suitability of a particular distribution to describe a collection of data, however for comparatively small sample sizes these tests usually can not exclude any of the distributions we discuss here. (As will be seen, the choice of distribution model can have an enormous influence on perceived reliability.)

The formulation of the lognormal distribution is as equation 1, but with x representing the logarithm of cyclic life rather than the actual cycle count. It is interesting to note that unlike the normal distribution where the mean, mode, and median are coincident, the lognormal distribution is skewed and thus these points occur at different locations in the population. Let μ be the location parameter, the mean of the logarithms, where $x = \log_e$ (cycles), and σ^2 be the variance of the logarithms. The mean of the cycles can be determined from $mean_{cycles} = \exp(\mu + \sigma^2/2)$. The mode is $mode_{cycles} = \exp(\mu - \sigma^2)$, and the 50th percentile, the median, is $median_{cycles} = \exp(\mu)$. Thus the mode is less than the median which is less than the mean. (The median always resides between the mode and the mean for any distribution.) As can be seen, the amount of skewedness depends on the relative size of μ and σ^2 . The point of all this is that the mean of the lognormal distribution is NOT simply the exponentiation of the logarithmic mean.

¹ In the philosophy of statistics population parameters such as μ are unknowable (because the population is infinite) but can be *estimated* from samples drawn from the population. The estimate is distinguished from the population parameter by a superscribed caret, eg: $\hat{\mu}$. This distinction adds little to our discussion and will not be followed here.

The Weibull Distribution

The Weibull distribution has enjoyed increased popularity in engineering applications in recent years, largely due to its flexibility and ease of use. It is the "Crescent Wrench" of statistical distributions: a single distribution can be used to approximate a variety of probability densities. The most common form of the Weibull is as its cdf, given in equation 2.

$$F(x) = 1 - e^{-\left(\frac{x-t_0}{\eta}\right)^\beta} \quad [2]$$

η is the "characteristic life," or 63.2 percentile. It acts as a location parameter and also a scale parameter. β describes the distribution's shape, and it also influences the distribution's dispersion. See figure 2. The third model parameter, t_0 , is an offset below which there is zero probability of failure. In many applications this is assumed to be zero and doesn't appear in the equation. It should be used with great care, since it defines the cyclic life with 100% probability of success.

The Beta Distribution

Although not as common among practicing engineers, the Beta distribution provides a useful description of some engineering situations. See figure 3. As with the previous distributions, the Beta is continuous, but unlike them it is defined on a finite interval. It can be symmetrical or skewed either right, as the lognormal, or left depending on its parameter values. The Beta distribution is given by equation 3.

$$f(x) = \frac{1}{x_2 B(a, b)} \left(\frac{x-x_1}{x_2}\right)^{a-1} \left(1 - \frac{x-x_1}{x_2}\right)^{b-1} \quad [3]$$

where $x_1 \leq x \leq x_2$ is the range over which x is defined, and $B(a, b) = \int_0^1 x^{a-1} (1-x)^{b-1} dx$. (This constant, as with the unwieldy constant in equation 1, is such that the integral of the resulting probability density is unity, ie: 100%.)

Because it is defined on an interval, (x_1, x_2) , the Beta distribution lends itself better to situations where x might represent a failure location which is geometrically constrained to occur within specific bounds, rather than cycle count.

Comparing Life Models

The methods for estimating distribution model parameters usually include a plot of the observed cdf on a grid representing that particular distribution. The data are sorted smallest to largest according to cyclic life, and each is assigned a quantile, estimated² by

² This formulation represents the median rank of the quantile. Other representations are also in common use, such as the mean rank, $F(i) = i/(N + 1)$. The differences are minimal and have little influence on the qualitative results presented here.

$F(i) = (i - 0.3)/(N + 0.4)$, where i is 1, 2, 3, ... N and N is the total number of observations in the sample. Figure 4 presents the cdf for the lognormal. The seven observations lie exactly on the line because they were defined to have come from this distribution. An actual random sample from the same distribution would exhibit noticeable scatter about the linear relationship, and not this idealized linearity. These observations were selected to illustrate their behavior when they are assumed to have come from other distributions. The point here is that several distributions could have given rise to these observations, as is illustrated by Figure 5 for the normal, 2 parameter Weibull, and lognormal.

Notice that while the cdf plots (figures 6 and 7) imply that the 2- and 3-parameter Weibull provide reasonable models for these seven pseudo-lifetimes, comparison with the resulting pdf indicates otherwise. Consider the 3-parameter Weibull. The centers of the lognormal and Weibull have similar shape, so the model works well over the range of data available. The behavior in the tails is radically different, as is seen in Figure 8. The difficulty is that, in actual practice, neither curve is known and so the only comparison possible is in this center region, and both models work well there.

The Beta model was selected to approximate the lognormal over a much wider range of cyclic lives. Notice that this would be impossible in practice, since the behavior of the tails would be unknown, and appears here for illustrative purposes. Figure 8 shows the Beta to be a reasonable model over a wide range. Even in this circumstance, however, the model differences would result in estimating a zero probability of failure prior to 1688 cycles, whereas the "true" (by definition) probability of early failure is 0.1%.

"Confidence" Intervals

It is often suggested that some of the difficulties associated with inferences based on small samples could be overcome by calculating confidence intervals for the quantiles. Philosophically, the sample at hand (the seven observations in this case) would be but one possible realization of a random sample of seven. Another sample would provide similar, but different numbers, and thus a similar, but different, estimate of the quantile. As the discussion continues, many samples of seven could be collected, and the lower quantile estimated from each. The confidence level (say 90%) is interpreted to mean that 90% of the quantiles estimated this way would include the unknown true value for that quantile. In many circumstances such a confidence estimate can be very valuable, especially when dealing with a small sample from a known population distribution. Implicit in any confidence calculation, however, is that the form of the underlying population distribution is known. This unspoken assumption is too often also forgotten. Thus a confidence interval is estimated based on the assumption of, say, a normal distribution, and the quantile, 1/1000 for example, is quoted with a high degree of confidence. The actual behavior could be radically different, simply because the underlying distribution was other than normal (or whatever had been assumed). Thus the "confidence" is more that the underlying distribution is what it was (implicitly) assumed to be than that a true value resides within an interval.

Alarming High Estimates of Risk

Thusfar, the examples were selected to show how an underestimation of structural reliability could arise, even though the statistical tools were correctly selected and applied, but the underlying assumption of a specific distribution was in error. There is also the potential of calculating an unrealistically high potential for disaster, again because the assumed distribution was not correct. Consider, for example, the behavior of the normal distribution. The seven idealized observations produce a normal distribution with values for lifetime that are less than zero. Clearly, this is silly. The physics of the process require that lifetimes be greater or equal to zero, so the silliness is obvious. Yet, if a similar sample were collected for material strength, or material elongation, for example, and these were assumed to be normally distributed when in actuality they were lognormal, then a similar situation results. The posited distribution (normal) would permit material capabilities lower than what could actually occur, and risk estimates based upon them would be alarmist.

Monte Carlo Simulation in Risk Assessment

The discussions heretofore have dealt with single distributions of a parameter of interest, usually cycles-to-failure. In most applications this distribution is unknown, but can be simulated using Monte Carlo methods. Briefly, the life-controlling variables are assumed to have particular statistical distributions and therefore some values (of stress or temperature or some other parameter) are more likely than others. These distributions are sampled from, and the resulting structural capability computed from the physical model of the system. The process is repeated, perhaps tens of thousands of times, and the resulting distribution of capabilities (eg: lifetimes) is constructed. The quantile of interest can then be determined directly. In this situation it is the modeling of the life-controlling variables themselves, rather than a model of the cyclic longevity, that present potential for trouble. Just as before, inappropriate statistical model selection can result in an aggregation of inaccuracies which culminate with erroneous failure lifetimes, and thus with erroneous estimates of risk.

Summary

Engineering use of statistical tools to assess potential structural risk represent a major improvement over previous methods based largely on empirical techniques. In many applications, however, these statistical tools are used with insufficient regard to the theoretical foundations on which they are built. The result can be an analysis which is correct in form and function, but considerably in error in its result. This apparent non-sequitur is often overlooked out of ignorance. We have presented a cursory overview of some common probability distributions and illustrated how this difficulty can arise in practice. As with most engineering problems, diligence in the application of fundamental principles must be the first step toward a solution.

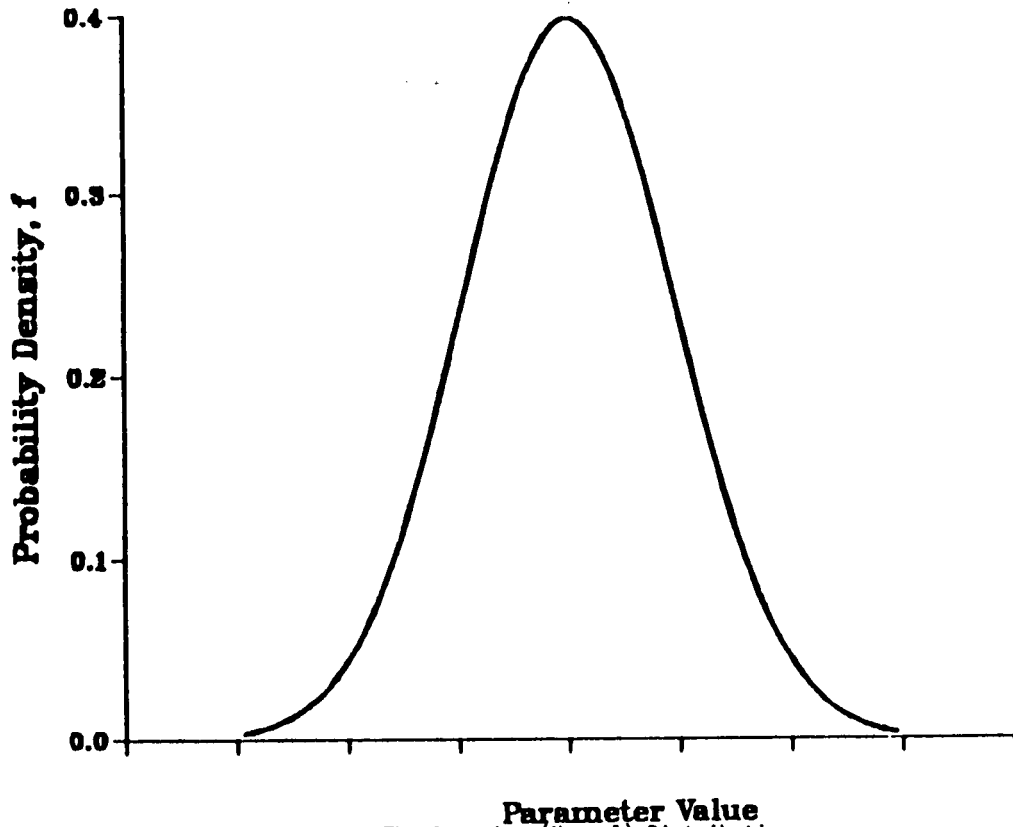

Figure 1: The Gaussian (Normal) Distribution

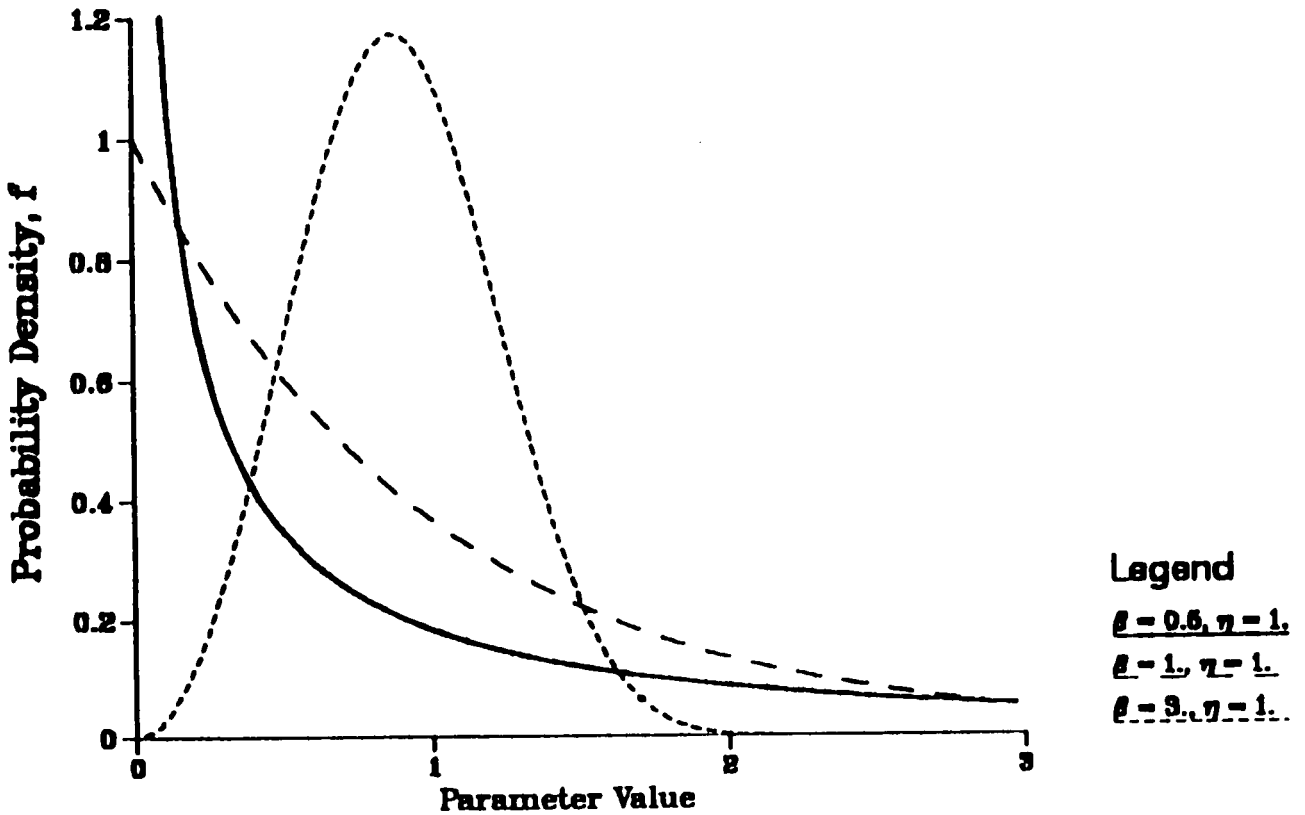

Figure 2: The Weibull Distribution With Various Scale and Location Parameters

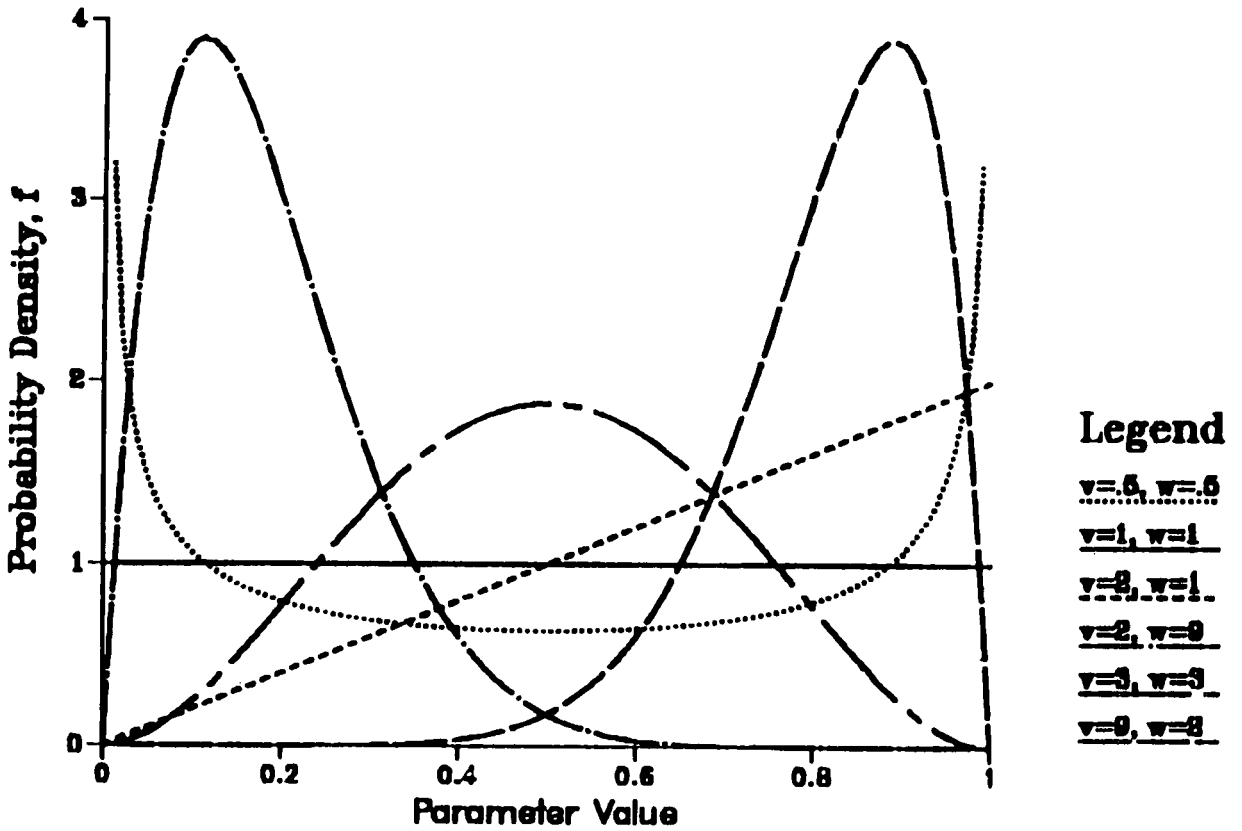

Figure 3: The Beta Distribution; v and w Correspond to a and b in Equation 3

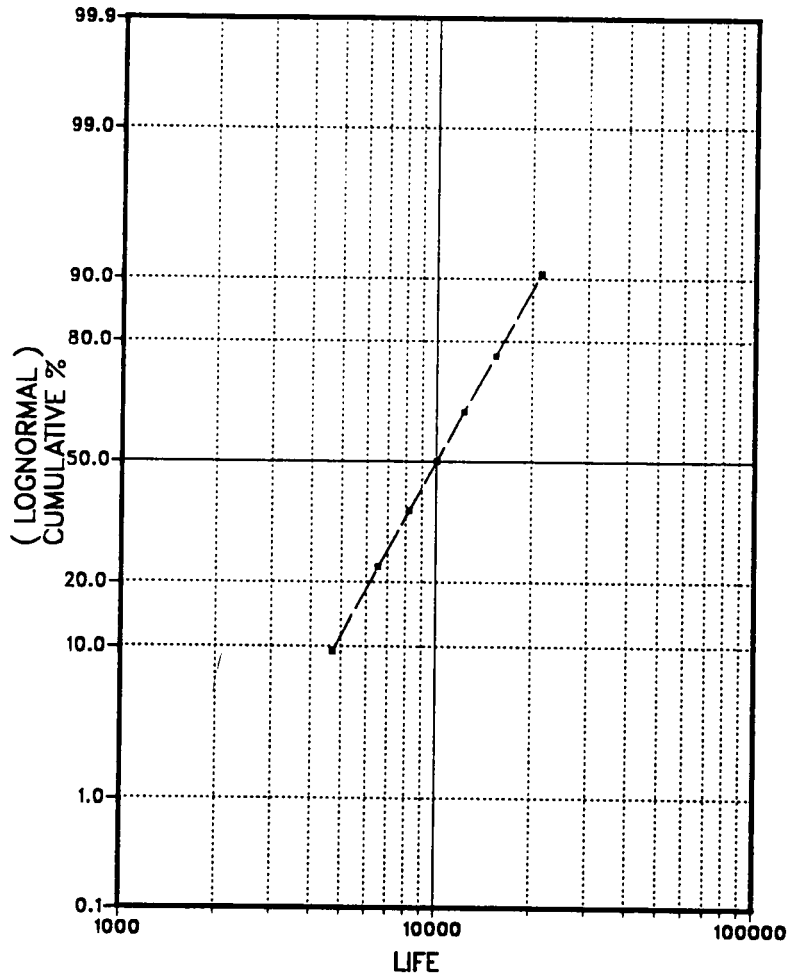

Figure 4: Lognormal CDF for Fatigue-type Data

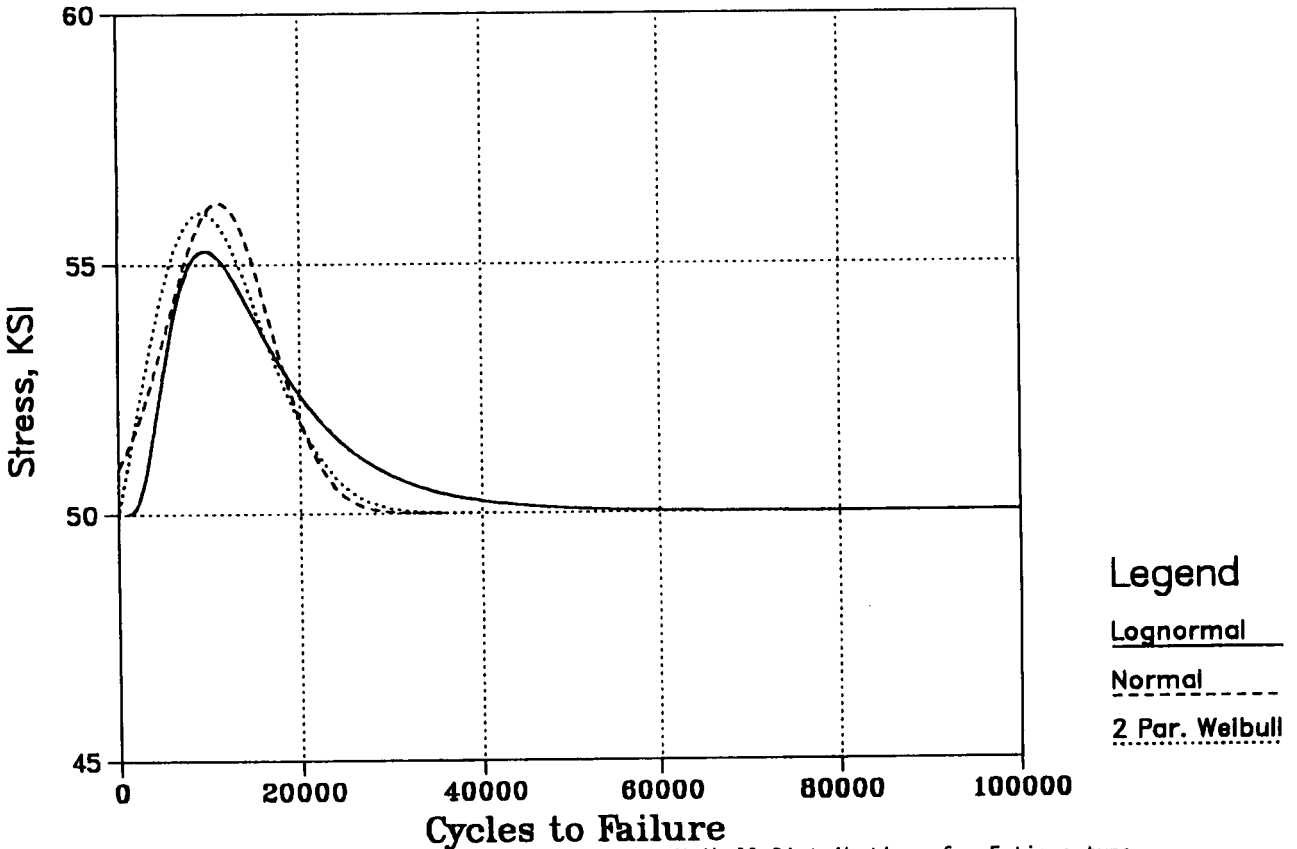

Figure 5: Lognormal, Normal, and 2 Parameter Weibull Distributions for Fatigue-type Data Show Similar Behavior Near the Center and Different Tail Behaviors

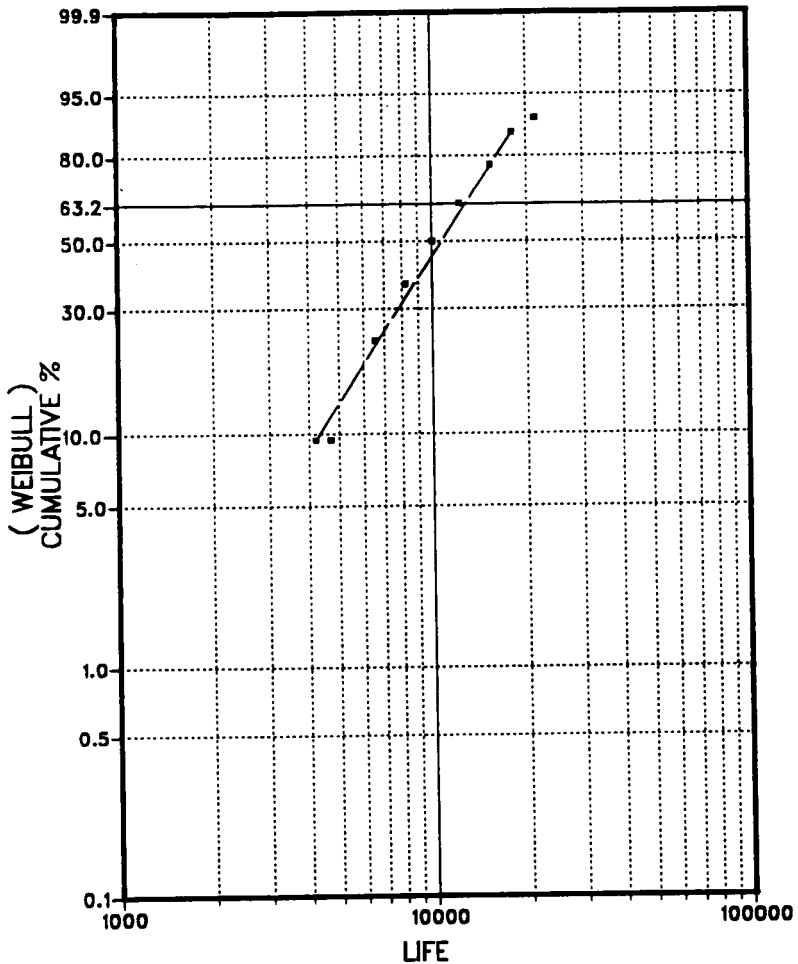

Figure 6: 2 Parameter Weibull CDF for Fatigue-type Data

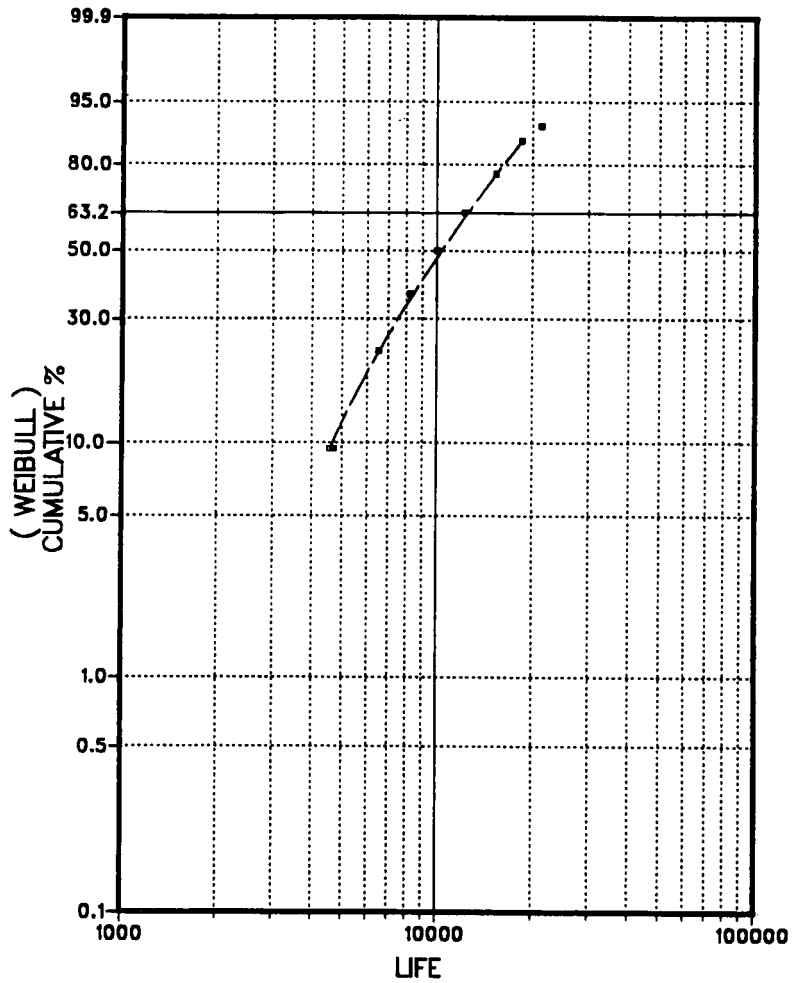

Figure 7: 3 Parameter Weibull CDF for Fatigue-type Data

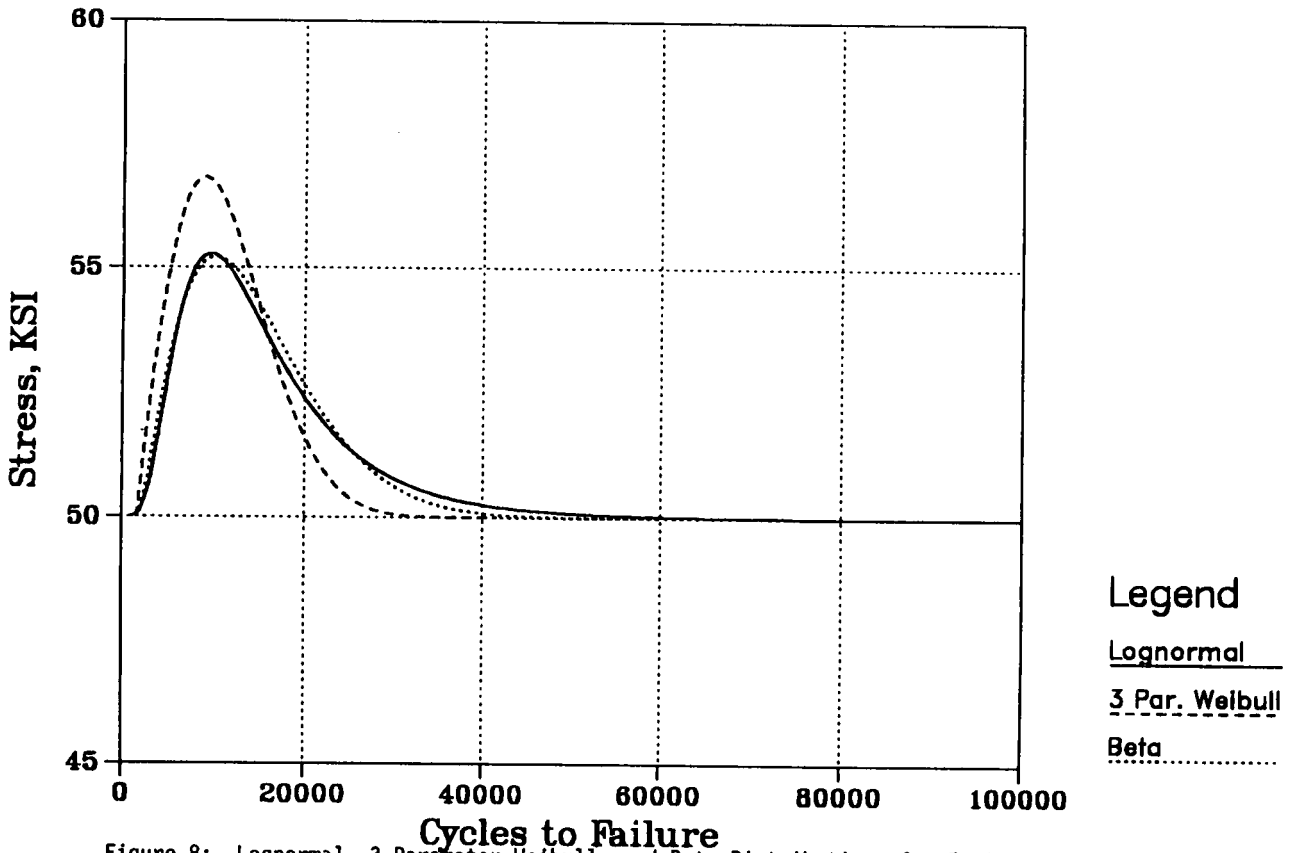

Figure 8: Lognormal, 3 Parameter Weibull, and Beta Distributions for Fatigue-type Data Show Similar Behavior Near the Center and Different Tail Behaviors

DEFECTS AND THEIR EFFECTS ON THE INTEGRITY OF NICKEL BASED AEROENGINE DISCS

G.F. Harrison

P.H. Tranter

Defence Research Agency, Pyestock, Farnborough,
Hampshire, GU14 0LS, UK

L. Grabowski

Rolls-Royce plc, PO Box 31, Derby, DE2 8BJ, UK

SUMMARY

By specific reference to the powder metallurgy alloy API the paper examines the role of defects in generating local residual stress fields. The effects of defect size and location on crack initiation and low cycle fatigue life are discussed. It is shown that at stress levels consistent with those experienced by current engine components, defects can act under cyclic loading as crack nucleators from cycle 1. Methods of calculating appropriate stress intensity factors are briefly reviewed and it is shown that at existing turbine disc operating temperatures, a linear elastic fracture mechanics stress intensity factor can be used to calculate crack growth rates. Finally, the major lifing methods used for aeroengine discs are briefly reviewed and attention drawn to the specific problems created by the presence of macrostructural defects.

1 INTRODUCTION

Since the conception of powered flight, with every new engine the design engineer has had the major technical objective of significant performance improvement over previous engines. In addition, the engine customer has been concerned to ensure that due attention has been paid to minimising specific fuel consumption and to reducing overall cost of ownership. The path to success lies in increasing engine thrust-to-weight ratio whilst reducing the number of aerofoil stages in the engine. Thus, in general, with every new engine, each stage has to do more work in a more hostile environment. Consequently, for such components, the increased pressure ratios and operating temperatures have resulted in the development of higher strength materials.

To meet the demanding physical and mechanical requirements, nickel based

materials have been alloyed to the extent that, for the most advanced high strength materials, conventional casting and forging manufacturing routes are no longer capable of producing segregation free materials. This in turn has led to the development and introduction of powder metallurgy processing procedures. However, in addition to the carbides and brittle second phase particles which are found in conventionally processed superalloys, powder materials may also contain pores and inclusions introduced during atomisation and consolidation procedures.

Although the drive towards cleaner materials is an essential part of improving structural integrity, defects are unlikely to be eliminated completely. Since it is well established that microstructural defects are likely to affect fatigue crack initiation, it is therefore essential to understand their role in controlling component service lives. This paper will concentrate on the influence of defects on the life of high strength powder metallurgy nickel based alloys; specific reference will also be made to lifing procedures for conventional wrought nickel base alloys.

2 DEFECTS IN NICKEL BASED DISC ALLOYS

To meet the highest operating temperatures and component stress levels demanded of advanced gas turbines, it has been necessary to develop a series of progressively higher strength nickel based superalloys. The generic microstructure of these alloys consists of a face centred cubic gamma matrix and a large volume fraction of the ordered gamma-prime precipitate $Ni_3(Al,Ti)$. As already pointed out, all engineering materials contain microstructural defects and, in the case of conventional wrought superalloys, these include carbides, nitrides and microporosity. Although these features should be considered as defects in the sense that they may act as

crack nucleators, in most materials they can be regarded as normal structural features introduced for specific purposes such as grain boundary pinning or to provide grain boundary strength. In practice since both laboratory specimens and engine components will contain large numbers of these defects, laboratory specimen testing can be considered representative of component behaviour. Indeed, even in the absence of these particles, microstructural features such as grain boundary triple points, twin boundaries etc are such that for nominally elastic stresses well below the measured yield strength, local plastic strain deformation can be introduced at such features, leading to eventual crack initiation.

As the demands placed on these materials have increased, the trend in alloy development has been to higher volume fractions of the gamma-prime precipitate to the extent that the consequent severely segregated initial cast billet cannot be homogenised by conventional high temperature forging without the risk of severe cracking. To overcome these limitations powder metallurgy processing routes have been developed. Fig 1 shows the microstructure of a typical powder metallurgy disc material, Astroloy API, and consists of a gamma matrix and a gamma-prime precipitate distribution of three distinct sizes (0.05, 0.2 and 1.5 microns). The grain structure is essentially "necklace" and comprises large grains in the range 25 to 75 microns surrounded by re-crystallised grains in the range 5 to 10 microns. This structure has been developed to optimise resistance to both creep and fatigue processes. However, defects are a particular cause for concern in powder metallurgy alloys since in addition to the microstructural defects already discussed, macrostructural pores and non-metallic inclusions can easily be introduced into the material during the production process. Indeed, Figs 2 and 3 illustrate two major types of defects found in an early 1980s vintage API material. The material contains a concentration of approximately 200 non-metallic alumina based defects per kilogram, of mean surface length approximately 30 microns, Fig 2. The material also contains a concentration of approximately 230 pores per kilogram, with an approximate mean diameter of 20 microns, Fig 3. Macrostructural defects, because of their size, can have significant detrimental effect on component life. In practice, however, because of the low occurrence levels of such defects, their effects may not be identified through specimen or even full scale component testing.

Machining and impact damage may also be considered within the macrostructural classification of damage. However, although machining damage and impact damage which occur prior to entry into service may be

addressed through improved manufacturing control and inspection, foreign object damage after entry into service can only be addressed through statistical risk analyses or through a Damage Tolerance approach (see 7.3 and 7.4).

3 GENERAL RESIDUAL STRESSES AND THE EFFECTS OF PORES AND DEFECTS ON LOCAL RESIDUAL STRESSES

Aero engine components operate in rapidly varying thermal environments. It is this combination of transient temperatures and the induced thermal and mechanical loads on the weakest elements in the disc that potentially lead to component failure. Account must therefore be taken of both the effects of basic material properties on the general thermal and mechanical stress levels within the component and of the influence of these stress levels on the operating failure modes. Additionally there is a need for analytical assessment of the effects of any possible defects on local stress concentrations and, where this may lead to particle cracking, of associated local stress intensities.

3.1 General Residual Stresses due to Processing and Heat Treatment

Before evaluating the local residual stress effects due to the presence of defects it is essential to have accurate quantitative knowledge on the magnitude of the global residual stresses introduced during production and heat treatment. The additional surface residual stresses introduced during conventional machining and/or surface treatments must also be evaluated.

Aero engine disc forgings are frequently subjected to a quenching operation as part of the heat treatment devised to optimise mechanical properties. Such procedures induce high thermal gradients, leading to plastic deformation and high residual stresses. To achieve accurate prediction of component life, it is therefore essential to have available, detailed information on the magnitude and distribution of these stresses. Using strain gauge/hole drilling techniques, surface stresses can be estimated to within $\pm 10\%$ of the measured values (Ref 1). However for sub-surface stress levels, hole drilling techniques are relatively unsatisfactory and measured values are accurate to only $\pm 25\%$. Since X-ray and neutron diffraction techniques cannot penetrate large depths in nickel and titanium superalloys, it has been necessary to develop finite element analysis methods. The accuracy of such a technique can only be demonstrated for simple geometries such as illustrated in Fig 4 (Ref 2). However, provided the thermal boundary conditions are well characterised and appropriate materials property data are

available, calculated values should be acceptable.

3.2 Local Residual Stresses due to Defects

It is now becoming recognised that global residual stress distributions must be included in all analyses associated with component life prediction. However, in the presence of macrostructural defects, significant additional residual stress fields can result as a consequence of the mis-match in coefficients of thermal expansion between the hard inclusions and the soft matrix during cooling from typical solution treatment temperatures. The induced plastic strain in the ligament between the inclusion and the free surface increases progressively as these inclusions approach the surface (compare Figs 5 and 6) (Ref 3). Since the associated stress fields also increase, this supports the tendency for surface/near surface failures in such materials.

Where defects occur in close proximity, strain field interaction can result in an increased local plastic strain concentration. The effect may be quantified using a fracture mechanics approach in which account is taken of this interaction by assuming an effective starter crack size of greater dimensions than for the case of the isolated defect.

3.3 Local Residual Stresses due to Pores

Finite element modelling of the effect of pores and inclusions as local stress concentrators confirms that size, shape, location and basic physical properties all influence the stress fields local to the defects. A spherical sub-surface pore has a stress concentration factor of about 2. However, if compressed during subsequent manufacturing processes, analysis has shown that the deformed pore can have a peak stress concentration ranging from between 1.5 and 3.0 depending on the orientation of the pore within the operating stress field (Ref 3).

3.4 Surface Residual Stresses due to Shot Peening

Component machining operations can result in tensile surface residual stress levels typically up to 300 MPa. Such levels of near surface residual stresses have significant adverse effects on the lives of engineering components. To alleviate these detrimental effects shot peening is frequently employed to ensure compressive residual stresses in the surface region and hence to improve component Low Cycle Fatigue (LCF) life. After shot peening the residual stress profile has a characteristic shape irrespective of the material or shot intensity (Ref 1). Typically, shot peening of a conventional wrought nickel base alloy produces an order of magnitude life improvement.

For powder metallurgy alloys, where crack initiation from surface defects is a major contribution to the failure process, such treatments would be expected to provide even more significant improvements to LCF lives. However, such information is of a highly proprietary nature and little has been published on this topic.

4 EFFECTS OF DEFECTS ON CRACK INITIATION AND LOW CYCLE FATIGUE LIFE

When macrostructural defects are present in a material, size, shape and location all influence crack initiation life and hence the observed scatter in the LCF characteristics of the material. The effects of defect size are illustrated for a specially seeded cast of powder metallurgy AP1 in Fig 7 (Ref 4). Although these results do indicate a small influence of size, location is shown to be the critical factor influencing LCF life. The effects of a wider range in size are illustrated in Fig 8 where it can be seen that the presence of such defects can reduce LCF life by at least an order of magnitude.

In the above tests, sufficient impurities were added to ensure the occurrence of a defect at the specimen surface. However, in practice, non-metallic inclusions are likely to be present at much lower concentrations and hence failures may result from surface or sub surface defects or from freely initiating cracks. Indeed, over the range of lives appropriate to current aero engine components, the crack nucleation event alters appreciably depending upon the level of the imposed loading conditions. This point is demonstrated in Fig 9 which contains 600°C LCF results for conventionally produced AP1 material. Superimposed onto these are fracture mechanics crack growth life predictions for specimens containing "just sub-surface" defect of 120 microns size. Firstly comparing the results of the doped material, Fig 8, with the predicted crack growth lives it can be seen that for the 120 micron defect size, crack nucleation is a rapid process occurring on initial loading or within the first few hundred cycles. Thus in these situations the obtained lives depend almost wholly on the crack growth characteristics of the material. Secondly, returning to Fig 9, at the highest stress condition the shortest fatigue lives agree closely with the calculated crack growth lives. Thus the "longer lives" obtained at a stress level of 1080 MPa and below may be attributed to any defects present being sub-surface or indeed to the absence of defects. However as also shown in this figure, as stress levels are reduced there is a progressively larger difference between predicted crack growth lives and experimental lives. This illustrates that crack nucleation is assuming a greater influence on total life.

Indeed, for lives greater than 10^6 cycles only about 1% of the total life is now spent in growing the crack from a microstructural size to the defined end point.

5 DETERMINATION OF STRESS INTENSITY FACTORS

5.1 Linear Elastic Crack Growth

In the presence of freely initiated cracks growing by a stage II mode I process, Linear Elastic Fracture Mechanics (LEFM) stress intensity models can be used to predict the rate of crack growth and thus to evaluate component life. For loading levels appropriate to aero engine discs, LEFM is generally applicable although for critical locations and at the highest operating stresses, analysis methods must deal with local yielding by accounting for crack tip plasticity. Solutions are normally based on boundary element, finite element or analytical evaluations in which crack aspect ratio, crack position and operating stress field are taken into account to produce normalised solutions.

A general formulation for stress intensity solutions for planar cracks in three dimensional bodies is given by (Ref 5) :

$$\Delta K = M_g M_b M_s F(\sigma) \Phi (\pi c)^{1/2} \quad (1)$$

where M_g is a general correlation factor the form of which varies with crack type (corner, surface, sub-surface) and position on the crack front.

M_b is a back face correction factor and increases ΔK as the back surface is approached.

M_s is a side face correction factor.

$F(\sigma)$ is a function which accounts for the effect of complex stress field.

Φ is an ellipticity correction factor which modifies the stress intensity factor at a given position on a crack front to account for aspect ratio.

'c' is the distance from the centre of the crack to the position on the crack front at which the stress intensity is being evaluated.

This solution can be applied with corner, surface and sub-surface cracks and to circular and elliptic crack fronts in uniform and complex stress fields (it was used in the calculation of the crack growth lives for AP1 presented in Fig 9). Additional solutions of particular relevance to the presence of pores, inclusions and penny shaped cracks emanating from ellipsoidal cavities are available in a recently published handbook of stress intensity

solutions (Ref 6).

5.2 Effects of Plasticity

The two basic assumptions of LEFM are that the material behaves as a linear elastic isotropic continuum and that crack tip plastic zone sizes are small compared to other dimensions (it has been estimated that the monotonic plastic zone size must be less than 1/50th of the crack length if the near crack tip stress field is to dominate the crack tip plastic response). In practice it has been found that very small cracks show anomalous behaviour relative to conventional crack growth response. This anomalous behaviour therefore may be attributed to the inability of stress intensity factor range based on LEFM to characterise small crack behaviour. Inaccuracies arise both with respect to crack geometry modelling and to the modelling of crack closure. Various investigators have suggested that after loading, as the applied load is subsequently reduced the crack front closes. Hence below a certain level, although there is still a remote tensile stress being applied to the body, the crack tip is closed. The calculated stress intensity has therefore to be corrected to account for this. Elber, amongst others, proposed that only a fraction of the positive loading cycle was effective in propagating cracks (Ref 7). Thus from direct measurements of opening and closure he identified an effective stress for incorporation into stress intensity calculations defined as:

$$\Delta \sigma_{eff} = \sigma_{max} - \sigma_{op} \quad (2)$$

where σ_{op} is the opening stress level, ie the remote stress level at which the crack tip is open.

Where crack opening has not been measured, empirical approaches must be used to quantify the effects of crack closure. The Walker modified effective stress intensity range expression

$$\Delta K_{eff} = C \sigma_{max} (1-R)^a \sqrt{\pi a} \quad (3)$$

can be used to correlate small crack growth rates for a variety of stress ranges and R-ratios provided elasticity conditions are maintained (Ref 8). However problems can arise when significant local plasticity is present. This is particularly true where reverse compressive plasticity flow can occur since this effectively increases the peak tensile stress in the subsequent loading cycle. The magnitude of this effect has been illustrated in strain controlled small crack growth tests in

IN100 (Ref 9), where it has been found that for a constant stress intensity range, increasing the tensile strain range, $\Delta\epsilon$, from 0.6% to 1.2% increased growth rates by a factor of approximately 25. A modified stress intensity equation of the form:

$$\Delta K_m = CE(\Delta\epsilon_\epsilon + \Delta\epsilon_p)\sqrt{\pi a} \quad (4)$$

has been found to account for the effects of plastic strain. When correlated in terms of ΔK_m , the range in growth rate was reduced from 25 to approximately 2.

The Dugdale model uses crack surface displacement to calculate closure stresses during unloading (Ref 10). These stresses influence the plastic yielding at the crack tip on subsequent loading. Newman developed finite element programmes to simulate the plasticity induced closure and the plasticly deformed material in the wake of the advancing crack tip (Ref 11). For small cracks at high stresses, the plastic zone range is no longer small with respect to the crack size and to obtain the plastic zone corrected stress intensity range Newman developed the general expression:

$$\Delta K_{eff} = (\sigma_{max} - \sigma_{min})\sqrt{\pi d} F\left(\frac{\rho}{d}, \frac{r}{w}, \frac{d}{w}\right) \quad (5)$$

where ρ is the plastic zone length
 C is the crack length and $d = (C + \rho)$
 σ_{max} is the maximum applied stress
 σ_{min} is the minimum applied stress

The boundary correction factor F accounts for the influence of hole radius and specimen width w . An appropriate expression has been provided for calculating ρ .

5.3 High Temperature Crack Growth (Oxidation and Creep Models)

With the increased operating temperatures under which turbine and compressor discs now have to operate, progressively the interactive effects of cycling and sustained loading have to be taken into consideration. As shown for the cast and wrought alloy, Waspaloy, Fig 10 (Ref 12), although defects and porosity may influence the crack initiation stage, even at temperatures up to 650°C under fatigue crack growth cycling, crack growth rates can be correlated in terms of the conventional stress intensity factors. The figure also shows that for five minute dwell-on-load testing, crack growth rates can still be presented in terms of ΔK . At 550°C both dwell and non-dwell data overlap, indicating

that at this temperature cyclic stress alone controls crack growth rate. However, at 600°C and 650°C the introduction of the dwell period has produced significantly greater crack growth rates. This suggests that as engine operating temperatures increase above a critical temperature, crack growth rate will be controlled by a combination of cyclic and static processes. Indeed, metallographic examination of failed specimens has shown that at all three temperatures, under cyclic loading, the fracture mode is transcrystalline with fatigue striations clearly visible. However, at both 600 and 650°C, the introduction of the dwell periods results in a change in crack growth mode from transcrystalline to intercrystalline growth. There is evidence to suggest that such a transformation in fracture behaviour is not due to a dominance of creep deformation processes but rather to surface corrosion effects. Such a model has been proposed by Gayda et al (Ref 13) and as illustrated in Fig 11 the model can be used to sum the effects of cyclic and static deformation modes. It predicts well crack growth rates for this alloy. The equation has the general form :

$$da/dN = (da/dN)_f + \int (da/dt)dt \quad (6)$$

where the pure fatigue term is assumed to be

$$da/dN = B\Delta K^m \quad (7)$$

and the time dependent contribution is assumed to be

$$da/dt = AK^s \quad (8)$$

which for triangular loading leads to

$$\frac{da}{dN} = B\Delta K^m + AK^s \left\{ \frac{(1-R^{s+1})/(1-R)^{s+1}}{(V(S+1)) + t_h(1-R)^s} \right\} \quad (9)$$

where A , B , m and s are material constants
 V is the frequency of the base line waveform
 t_h is the length of dwell at peak load
 R is the stress ratio.

The results are consistent with findings of Gayda et al for Rene 95 at 650°C and two minutes dwell. However the use of ΔK as a correlating parameter and the experimental observations suggest that rather than "creep

damage" such effects are more appropriately identified as "environmentally enhanced crack growth".

To date, time dependent crack growth does not occur in practice to any great extent since designers use materials in the elastic region with only small excursions into elastic-plastic conditions. Additionally, when sustained loading does occur in service this is most likely to be below the maximum operating conditions. Thus for sustained loading at elevated temperatures it may still be possible to use the conventional stress intensity range as a correlating parameter even when fracture surfaces show clear evidence of time dependent intercrystalline crack growth.

However, at the highest engine operating temperatures, time dependent creep processes are now beginning to assume greater influence on the behaviour of engine discs. Under such conditions the importance of dwell periods on overall crack growth rates would be expected to increase. Correspondingly, the requirements for non-linear correlating parameters such as the C^* parameter would also be expected to increase.

Cumulative damage models based on the C^* parameter have been developed and applied to creep fatigue crack growth in a variety of materials at elevated temperatures (Ref 14). This approach assumes that creep and fatigue components of crack growth can be added linearly to allow total crack growth per cycle to be expressed as:

$$\frac{da}{dN} = \frac{1}{f} \left(\frac{da}{dt} \right)_c + \left(\frac{da}{dN} \right)_f \quad (10)$$

where the first term gives the creep contribution and the second term that due to fatigue. In practice the first term can be expressed as:

$$\dot{a} = \frac{3C^{*0.85}}{\epsilon_f} \quad (11)$$

where \dot{a} is the crack growth in millimetres per hour
 C^* is in $\text{MJ/m}^2 \cdot \text{h}$
 and ϵ_f is the uniaxial creep ductility.

The second term is given by the Paris equation modified to account for crack closure effects. For AP1 the sensitivity of crack growth rate to ΔK and to C^* are illustrated in Figs 12 and 13. It can be readily seen that at such temperatures C^* is the better correlating parameter.

6 IMPLICATIONS FOR AERO ENGINE COMPONENTS

There is considerable experimental evidence to suggest that if constant load amplitude crack growth is interrupted by a single overload cycle, the rate of the initial subsequent crack propagation under the original cycle may be reduced. Correspondingly a large compressive overload may result in a period of accelerated growth. In practice, although airframe structures may experience severe overload effects, engine components experience only relatively minor overloads due to the major throttle movement during the take-off and landing stages of the flight profile. In practice, these are the operating conditions generally used in the design process and although it has been found experimentally in IN100 for example that a maximum overload ratio of 1.5 can reduce subsequent growth rates by as much as a factor of 4, for simulated mission cycling, relatively little retardation is in fact experienced (Ref 9). Thus it would appear that major throttle movements do not cause severe overloading and that any subsequent retardation is never fully developed prior to the next major cycle.

7 COMPONENT LIFE PREDICTION IN THE PRESENCE OF DEFECTS

All materials contain defects and hence any viable lifing methodology must address directly or indirectly the effects of these defects on component life. The various approaches to component lifing can be incorporated within three general categories, namely, safe life/database lifing, damage tolerance/retirement for cause and probabilistic lifing procedures. Considering these in turn:

7.1 Safe Life

For many years the Predicted Safe Cyclic Life (PSCL) methodology has been the basis of lifing procedures for critical rotating parts and is incorporated into engine disc certification requirements. In this approach parts are designed for a finite service life during which it is assumed that no significant damage will occur. No in-service inspections are necessary and safety is ensured by requiring components to be withdrawn from service before any detectable cracks have appeared (in this context "detectable" equates to a surface crack of length 0.75 mm).

This approach can be used when the defect density is sufficiently high to ensure that specimen tests are representative of the general material behaviour. For such situations there is a financial attraction in specimen testing as compared to full component testing. Additionally, with respect to the derivation of appropriate probabilities of

failure and associated confidence levels, sufficient specimen tests to satisfy the appropriate statistical evaluation procedures can more easily be undertaken. Specimens may reflect accurately both defect density and distribution and also appropriate component finishing standards, however, residual stresses due to processing and heat treatment are not easily represented in such testing. Although there is an acceptance of specimen testing in US lifing requirements, component testing remains the basis of UK lifing requirements.

In order to establish safe service lives, appropriate statistical procedures must be applied to representative test results to obtain a minimum property fatigue design curve. European Joint Airworthiness Requirements for civil engines (Ref 15) operate on a failure rate (ie first crack) such that at the declared service life, to a level of confidence of 95%, not more than 1 in 750 will have a crack of surface length greater than 0.75mm. The mandatory levels are set to take account of scatter and to ensure that the weakest component is withdrawn from service whilst still having an adequate margin of safety. Although not identified in the regulations the method for calculating the PSCL is based on the equation:

$$PSCL = \frac{N_{sm}}{\left(\frac{N_{max}}{N_{min}} \right)^{\frac{1}{6_{sd}} \left\{ \frac{h}{\sqrt{n}} + \lambda \right\}}} \quad (12)$$

- where N_{sm} is the geometric mean of the sample
 N_{max} is the $+3\sigma$ test life derived from spin pit testing of full sized discs
 N_{min} is the -3σ test life derived from spin pit testing of full sized discs
 6_{sd} is the number of standard deviations across the scatter band
 h is the number of standard deviations between the mean and the 95% point on the probability density function (= 1.645)
 λ is the number of standard deviations between the sample mean and the 1 in 750 failure position (=3)
 n is the sample size

Additional assumptions in the lifing regulations are that disc LCF lives show log-normal distribution and the life ratio between the $+3\sigma$ disc life and the -3σ disc life is not more than 6 to 1.

For conventional materials the basic method and the simplifying assumptions regarding fatigue scatter have withstood the test of time.

Thus in-service disc failures are an extremely rare occurrence and even when these remote events do occur they are generally attributable to failure in process control rather than the statistical lifing model.

However, for powder metallurgy materials and components containing defects, although the safe life approach may still be valid it must be adopted with extreme caution. In particular the assumption that the ratio in fatigue life distribution between $+3\sigma$ and -3σ is 6 to 1, may no longer be valid and the relevant value must be established from appropriate testing. The caution necessary in determining this value can be illustrated by examining some 600°C LCF data for the powder metallurgy material AP1 (Ref 16) as shown in Fig 14. From the sample of 33, 0.9% strain LCF test results the range in fatigue lives obtained is approximately 6. Applying median ranking methods the derived range in fatigue results between $+3\sigma$ and -3σ is 14. For 0.8% strain where only 10 test results are available, the range in fatigue lives obtained is again approximately 6, however in this case the derived range between $+3\sigma$ and -3σ is approximately 80. This illustrates the importance of adequate sample size in such determinations and the caution which must be applied if a safe life approach is used for such materials.

In an extension to safe life PSCL, it is now accepted by both the CAA and FAA Regulatory Authorities that the life end point can be taken to be either the traditional life-to-first-engineering crack (0.75mm surface length) or to be a fraction of the life to rapid fracture. A figure of $\frac{2}{3}$ burst life has now become acceptable in the latter context. This approach has the advantage that for all materials it provides a constant ratio between the declared component lives and life to eventual failure.

7.2 Database Lifing

In the standard safe cyclic life approach, each disc feature has to be individually analysed and for every new design of disc a fatigue design curve corresponding to the specific geometry has to be established from appropriate disc spinning tests. The fracture mechanics database approach has been developed as a means of accounting for the widely different geometries and stress field pertaining to critical component features thus enabling the compilation of a common database. The fracture mechanics methodologies discussed earlier enable the prediction of the number of cycles needed to grow a crack of an initial size, a_0 , to a final size, a_f . Conversely it follows that if the number of cycles required to produce a crack of length a_f is known, it must therefore be

possible to back-calculate an initial effective starter crack size, a_i . The fracture mechanics method can take account of varying stress field, ie component geometry, hence for all the discs of a material that are fatigued tested the initial effective starter crack sizes can be determined, as illustrated in Fig 15, and combined into a common database. Using a three parameter Weibull statistical model it is then possible to represent the distribution of initial starter crack sizes and from this to determine the maximum probable initial effective flaw size. This value can then be used in forward growth calculations to determine component lives for all discs to which the database applies. Fig 16 shows calculated initial crack sizes for a typical wrought material plotted in terms of the Weibull model. Fig 17 presents the statistical distribution ratio of achieved disc life to minimum life predicted by the database approach for Waspaloy (Ref 17). The range in the predicted results helps substantiate the safe life assumption for conventional materials that the range in life between the $+3\sigma$ life and the -3σ life is not greater than times 6.

In practice difficulties can arise in component lifing with respect to quantifying accurately the crack initiation and small crack growth stages for which continuum mechanics models do not apply. Such difficulties are enhanced by the presence of porosity and defects. However, since database quantifies the total component life it should automatically take account of both these aspects without requiring detailed consideration of the initiation and small crack growth processes which may be involved.

7.3 Damage Tolerance

In damage tolerance approaches to component lifing, damage is assumed to exist in the newly manufactured component. This damage is considered to take the form of small defects in the material and the size is generally set by the minimum level detectable by the NDE system used in final inspection. Again the residual life of the component is then determined by applying fracture mechanics concepts to calculate the cycles required to grow this maximum initial defect, a_{NDI} , to a critical size, a_f . Finally, an appropriate safety factor is applied to account for the inherent variability in the crack propagation process.

Since a damage tolerant life is based on proven NDI identifiable size, in practice this life may be extremely short and hence uneconomical. However, when applied within the PSCL concept, damage tolerance may be used to enable appropriate safe inspection intervals to be determined. It can be applied when there exists a remote probability of a defect being present. As shown in Fig 18

these intervals are generally set at half the predicted crack growth life. If on subsequent inspection the component is found to be crack free it is returned for another service interval until the PSCL is achieved. It is emphasised that in this context at the PSCL not more than 1 in 750 discs should contain a crack. To assess the reliability of such procedures it is necessary to construct Probability of Detection (POD) curves for the NDI system. This requires a representative set of component test specimens for inspection and application of appropriate statistical procedures to analyse and correlate the results. Currently work is in progress to produce an appropriate civil version of the USAF Mil Standard (Ref 18) for NDE system reliability assessment.

7.4 Retirement for Cause

Under both safe life and damage tolerant lifing, nearly all discs are retired from service while still having a large proportion of their potential life unused. Indeed, as illustrated in Fig 19 for conventionally forged disc materials such as Waspaloy, 80% of discs have a life in excess of twice the declared PSCL.

In the safe life approach discs are withdrawn at a given probability of cracking for the whole disc population. In Retirement-For-Cause (RFC) on the other hand, retirement is not implemented until cracks have been identified in individual discs (Fig 19). RFC uses in-service inspections to declare iterative life extensions beyond the damage tolerant life thus in general enabling a higher proportion of potential disc life to be utilised.

Since the safety levels operating during any service interval depends on the defects present at the time of inspection, initially the safety level is critically related to the inherent defect distribution associated with the manufacturing route. Under conventional safe life and damage tolerant lifing methods at the PSCL, to 95% confidence, not more than 1 in 750 discs should be cracked. However, as service lives increase, the number of cracks initiating and growing during the service interval will also progressively increase. Thus, as also shown in Fig 20 for a typical powder metallurgy disc alloy such as AP1, as many as 88% of the discs have lives in excess of twice the PSCL. However, as service lives are extended beyond the PSCL and hence as more discs will be cracked at each inspection interval, to maintain the original safety levels the reliability of the NDE system must be increased. In practice, this can only really be achieved by increasing the detectable crack size. If this were to be implemented it would automatically lead to smaller available residual lives and hence to shorter inspection intervals thus rapidly progressing towards an unviable, uneconomical procedure.

7.5 Probabilistic Lifting Methods

Recently there have been several attempts to incorporate both POD curves and flaw size distributions into more comprehensive probabilistic risk analyses. These approaches take the form of randomised models for the crack growth process and may include in addition to initial flaw size distributions and inspection reliabilities, other factors such as critical defect size, location, stress levels and crack growth parameters as random variables. Such schemes require appropriate probability distributions for all the random variables involved. It is possible to construct a probabilistic fracture mechanics lifting model broadly similar to the deterministic damage tolerant approaches outlined earlier. However, the primitive variables of the deterministic models must now be replaced by random variables for which suitable distributions are identified. The valid implementation of probabilistic fracture mechanics therefore depends on the availability of appropriate distribution functions for the various random variables and hence on the generation of appropriate statistically significant databases. In simple deterministic fracture mechanics modelling, component life is derived by incorporating known values of ΔK , $\Delta\sigma$, a_i and a_f into the well known Paris equation

$$da/dN = C\Delta K^m \quad (13)$$

The application of such a crack growth equation identifies two further random variables, namely the parameters C and m. The database calculations of pseudo starter crack sizes can be represented through a Weibull distribution function, and it is considered that this type of distribution is also appropriate for true starter crack sizes. In addition, from a large number of crack growth results in API available to the Authors, it has been possible to show that the exponent 'm' in the Paris equation is independent of temperature and that the constant C has a log normal distribution and so the material variability in crack growth can be accommodated by a random variation in C rather than in a jointly dependent variation in C and m.

8 FINAL COMMENTS

Materials are not perfect structures and hence below any set levels of inspection, components contain structural irregularities and defects.

For conventional wrought materials, defects are small and their occurrence sufficiently frequent that both specimen and component

testing reflect accurately component behaviour in service. However, for situations where macrostructural defects or pores may be present, it has been shown that for high applied stresses these defects can act as cracks from the first loading cycle.

Fracture mechanics lifting calculations must take into account both general residual stress fields and stress fields due to mismatch between the defect and matrix expansion coefficients. Additionally effects of crack tip plasticity, crack closure, stress ratio and elevated temperature dwell must be included in lifting calculations as appropriate.

For materials containing macrostructural defects, if the traditional safe life methodology is used this must be with extreme caution and with appropriately determined scatter factors.

Database lifting overcomes the problems of identifying the separate crack initiation and crack propagation phases. Provided a sufficiently large 'starter crack' size database is available the effects of macro-defects should be allowed for automatically.

Damage tolerance lifting approaches based on NDI inspection levels lead to safe but extremely short service lives. However, if combined with safe life concepts damage tolerance should enable the full PSCL to be achieved even when a full materials database is not available. Additionally the approach should still be safe in the extremely unlikely event of a large macro-defect being present in the component.

In RFC as the number of components experiencing crack initiation within the service interval increase, to maintain a constant probability of failure (ie safety level) it is necessary to set *larger* size NDI limits. This leads to lower service intervals and rapidly becomes uneconomic.

Probabilistic methods have the potential capability to account for the effect of defect size and distribution. They replace recognised primitive variables currently used in fracture mechanics analyses by random variables of known distribution. However such procedures rely on Monte Carlo type sorting routines and although it is reasonable to assume that the distributions obtained are appropriate to the total disc population, such approaches are not yet fully established.

REFERENCES

1. Ezeilo, A.N., Webster, P.S., Webster, G.A. and Webster, P.J., "Development of the Neutron Diffraction Technique for the Determination of Near Surface

- Residual Stresses in Critical Gas Turbine Components", in "Measurement of Residual Stresses Using Neutron Diffraction", NATO Advanced Research Group, Oxford, 1991.
2. Craighead, I.W. and Towers, O.L., "Modelling of Heat Treatment Processes and Prediction of Residual Stresses", in "Proc. of 6th World Congress on Finite Element Methods; Finite Elements in the Design Process", Oct 1990, paper 63.
 3. Hussey, I.W., Venables, R.A. and Pickard, A.C., "Superclean Materials - Needs and Opportunities", in "Proc. of High Temperature Materials Preparation Engineering Conference", Sept 1990, part II, pp 1493-1512.
 4. Thompson, F.A., Butler, C.P. and Siddal, R.J., "The Influence on the Low Cycle Fatigue Properties of the Nickel Based Superalloy APK1 Produced via the Powder Route", 108th Meeting AIME, 1979.
 5. Pickard, A.C., "The Application of 3-Dimensional Finite Element Methods to Fracture Mechanics and Fatigue Life Prediction", EMAS, 1986 (ISBN 0 947817 22 0)
 6. Murakami, Y., ed, "Stress Intensity Factors Handbook", SMSJ, Pergamon Press, 1987 (ISBN 0 08 034809 2)
 7. Elber, W., "The Significance of Fatigue Crack Closure", in "Damage Tolerance in Aircraft Structures", ASTM STP486, 1971, pp230-242
 8. Walker, K., "The Effect of Stress Ratio During Crack Propagation and Fatigue of 2043-T3 Aluminium", ASTM STP462, 1970
 9. Romanoski, G.R. and Pelloux, R.M., "The Fatigue Behaviour of Small Cracks in an Aircraft Turbine Disc Alloy", in "Elevated Temperature Crack Growth", ed Hall, S. and Nickolas, N., ASTM USA 1990
 10. Dugdale, D.S., "Yielding of Steel Sheets Containing Slits", J. of Mech. Physics and Solids, 8, 2, 1960, pp 100-104
 11. Newman, J.C., "A Nonlinear Fracture Mechanics Approach to the Growth of Small Cracks", AGARD (NATO) CP328, 1982, 6.1-26
 12. Byrne, J., Hall, R., and Grabowski, L., "Elevated Crack Growth in a Nickel Base Superalloy", in "Behaviour of Defects at High Temperatures", Sheffield, 1992.
 13. Gayda, J., Gabb, T.P. and Miner, R.V., "Fatigue Crack Propagation of Nickel-Base Superalloys at 650°C", in "Low Cycle Fatigue", ASTM STP942, 1982, pp 293-309
 14. Dimopulos, V., Nikbin, K.M. and Webster, G.A., "Influence of Cyclic to Mean Load Ratio on Creep/Fatigue Crack Growth", in "Crack Propagation Under Creep and Creep-Fatigue", ASMI, Oct 1986, 8620-001.
 15. Joint Airworthiness requirements - E (Engines), Civil Aviation Authority, 1986
 16. Grabowski, L. and Harrison, G.F., "The Effect of Neuber, Strain and Load Control Testing on the Fatigue Behaviour of Astroloy at 600°C", in "Behaviour of Defects at High Temperature", Sheffield, 1992.
 17. Asquith, G. and Pickard, A.C., "Fatigue Testing of Gas Turbine Components", High Temperature Technology, 6, 3, 1988
 18. Military Standard Engine Structural Integrity Programme (ENSIP), MIL-STD-1783 (US DoD), Washington, 1984.
- © Copyright Controller of HMSO 1992

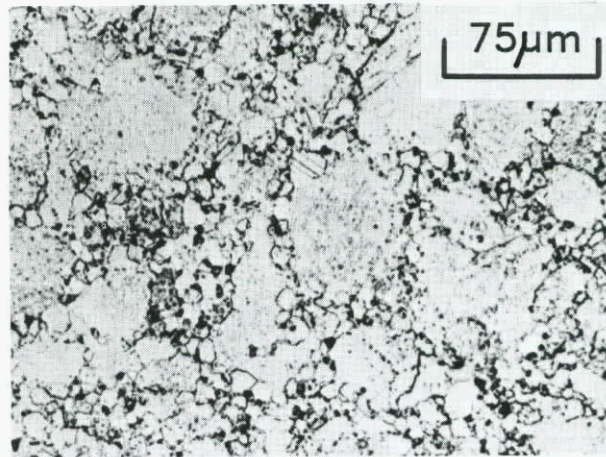

Fig 1 Microstructure of Astroloy

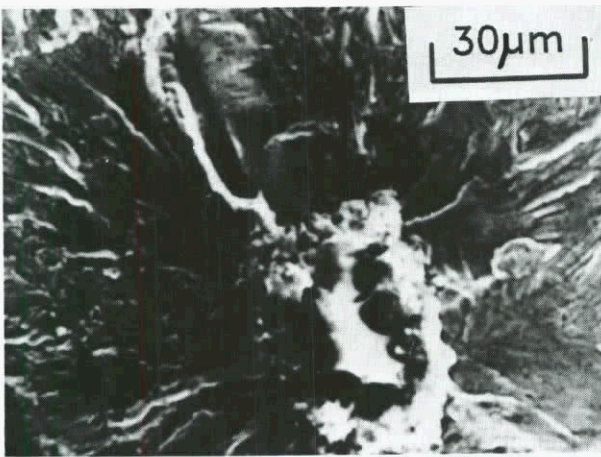

Fig 2 Failure site -
Non metallic inclusion

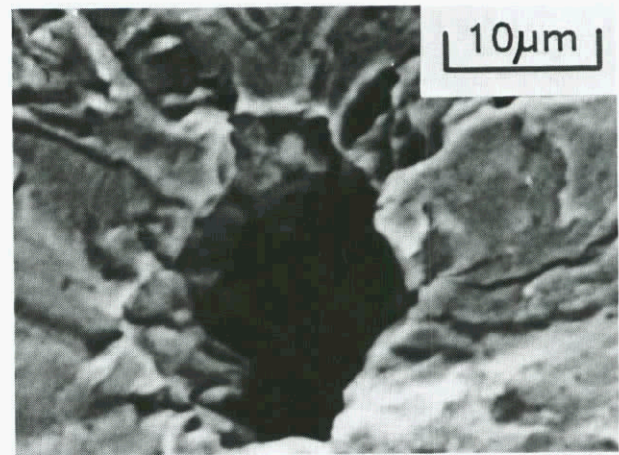

Fig 3 Failure site - Porosity

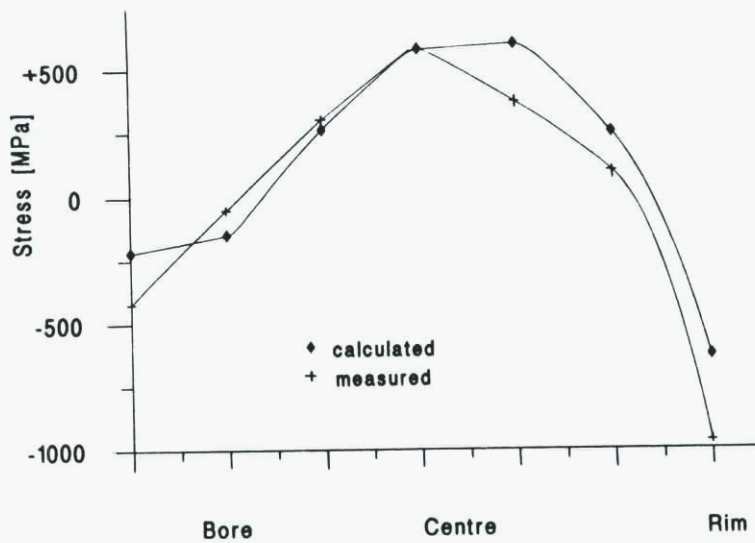

Fig 4 Comparison of measured and predicted residual hoop stresses in a plain disc

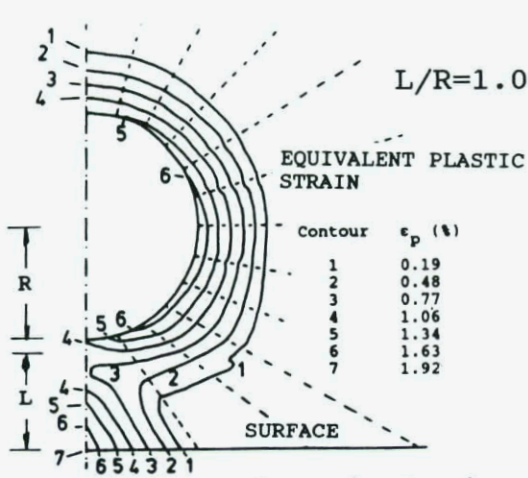

Fig 5 Near surface inclusion Residual strain field

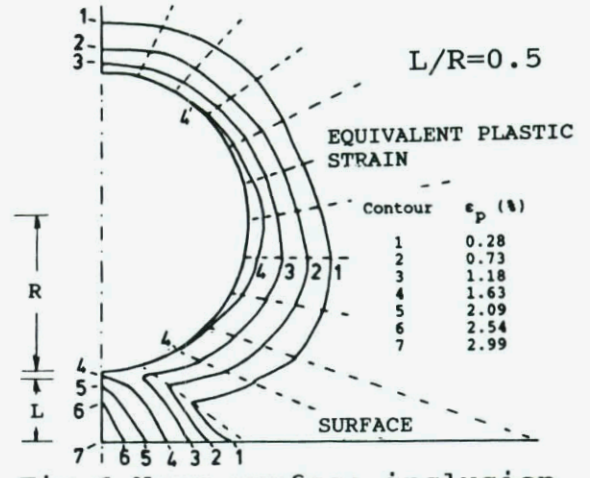

Fig 6 Near surface inclusion Residual strain field

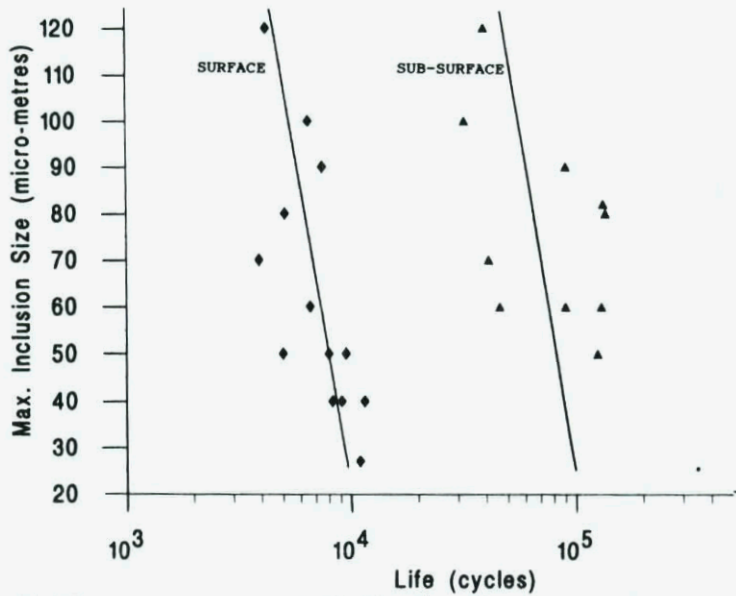

Fig 7 The effect of defect size and location on LCF life of seeded AP1 at 600 Deg.C

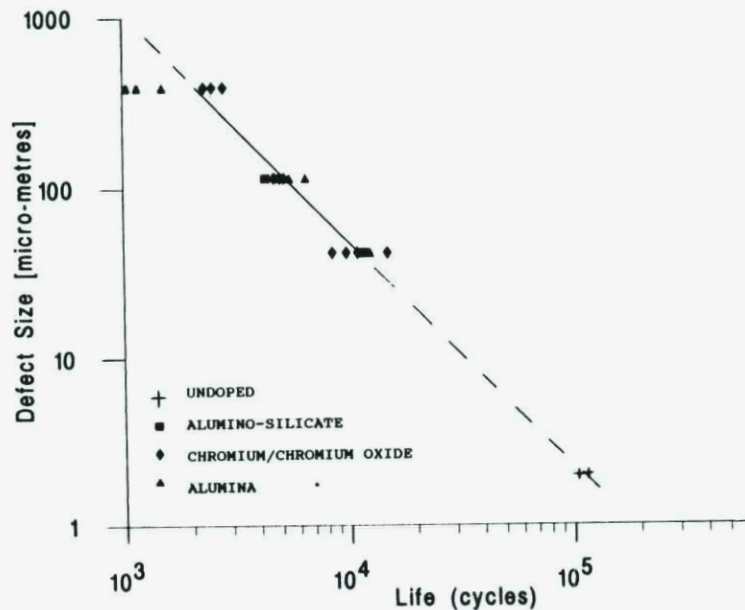

Fig 8 The effect of defect size on the LCF life of seeded AP1 at 600 Deg.C and 1080 MPa

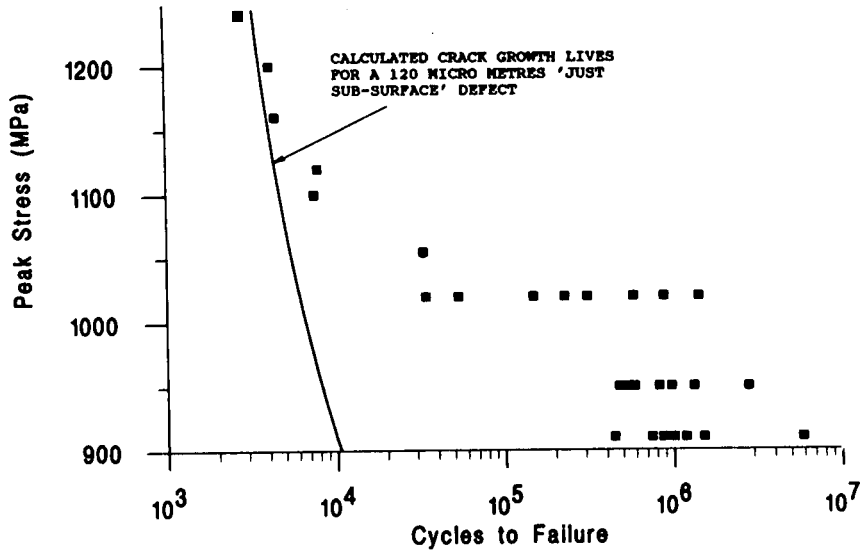

Fig 9 Load controlled LCF lives in AP1 at 600 Deg.C

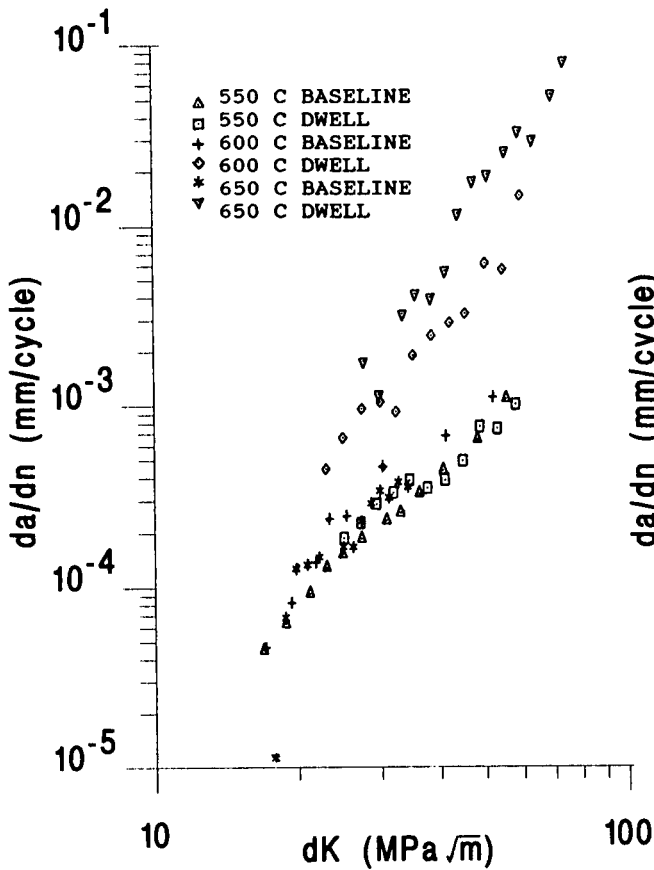

Fig 10 Base line (0.25 Hz) and 5 minute dwell crack growth in Waspaloy

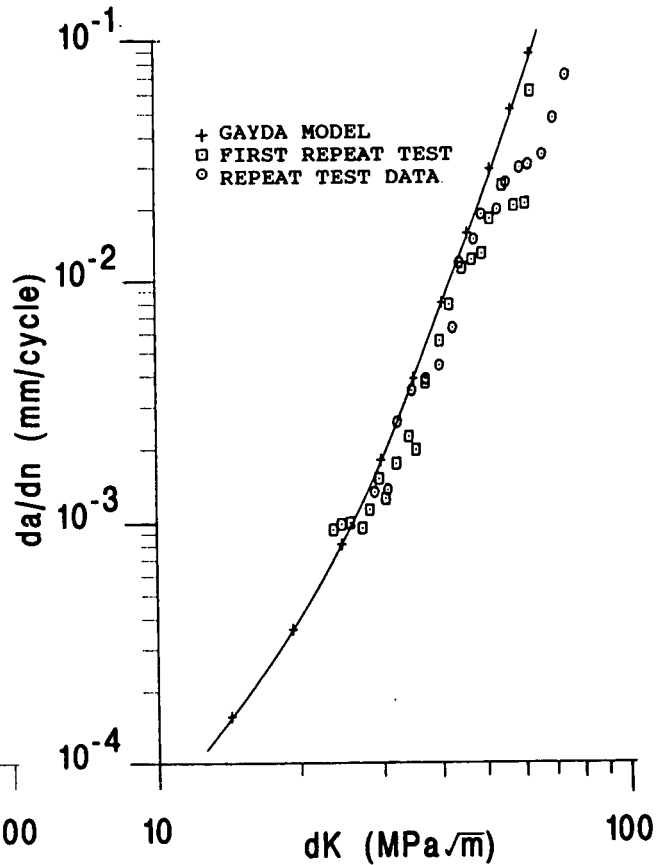

Fig 11 Comparison of predicted and experimental crack growth for Waspaloy at 650 Deg.C

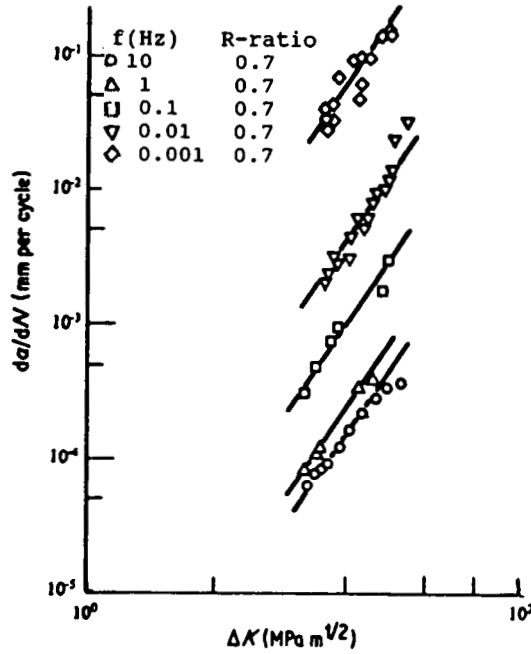

Fig 12 Effect of Frequency on crack growth in AP1 at 700 Deg.C

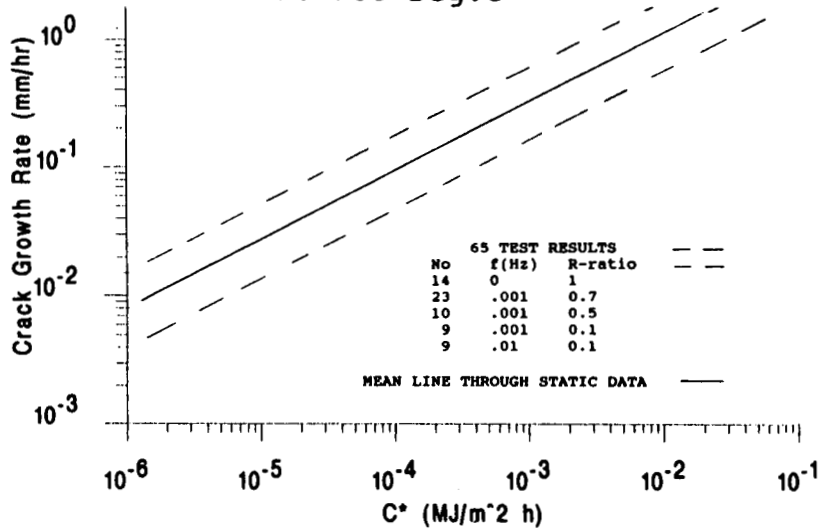

Fig 13 Sensitivity of crack growth rate to C* in AP1

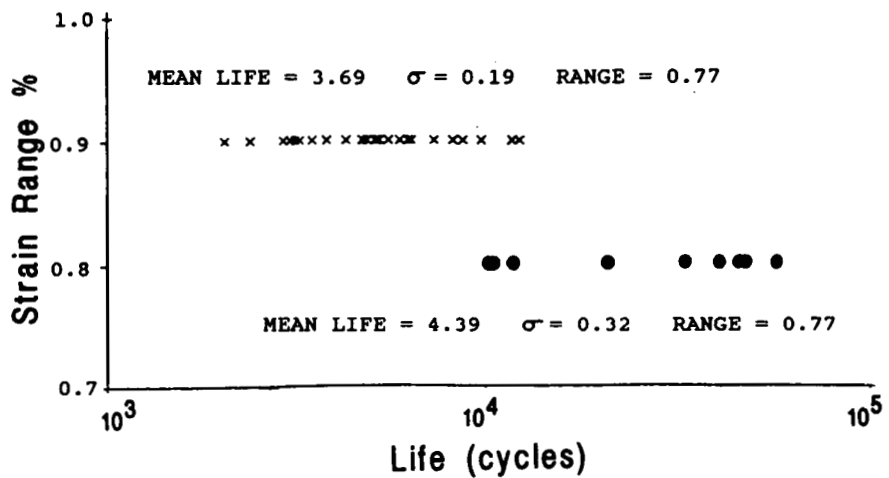

Fig 14 Fatigue scatter in AP1 under strain control cycling at 600 Deg.C

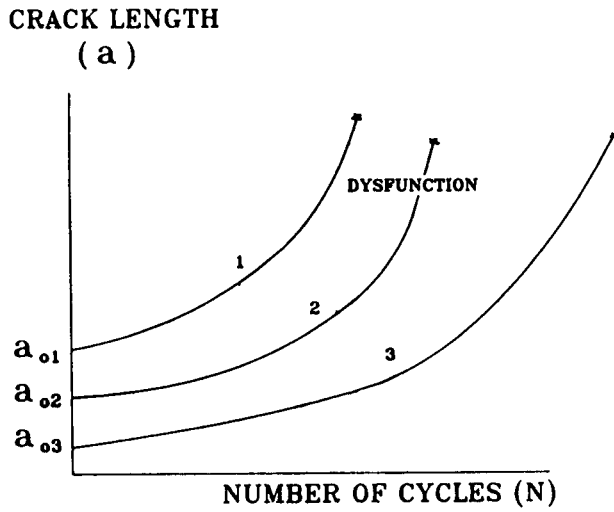

Fig 15 Back calculation of initial effective starter crack sizes

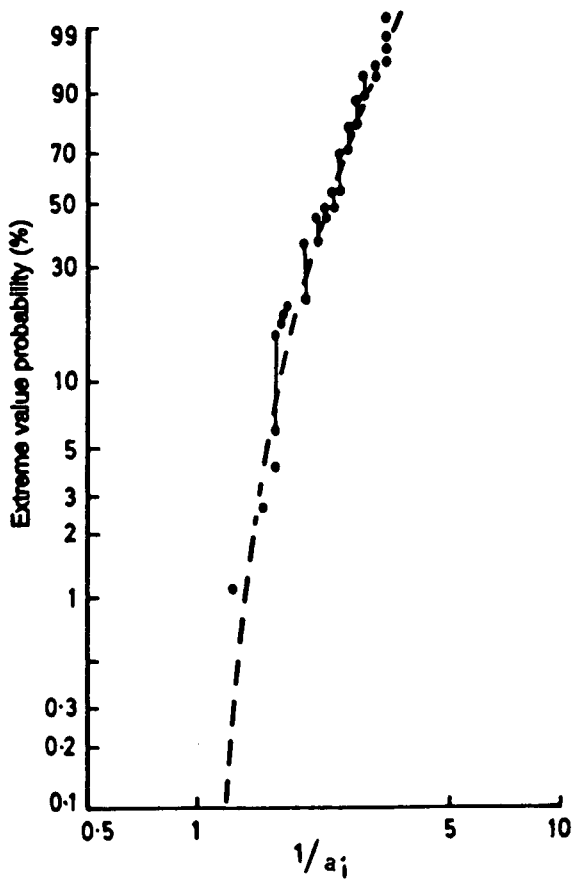

Fig 16 Typical distribution of material crack sizes for a wrought alloy

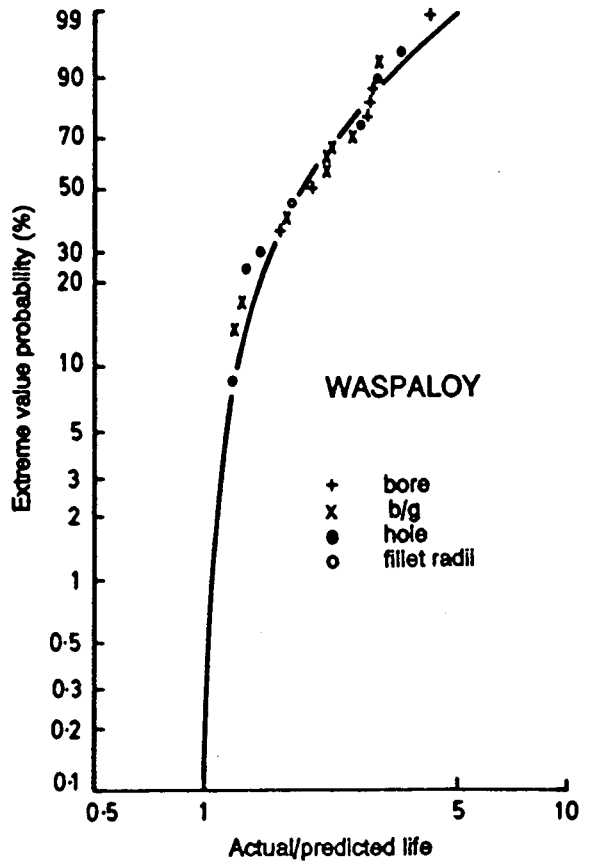

Fig 17 Comparison of actual and data base fatigue life predictions

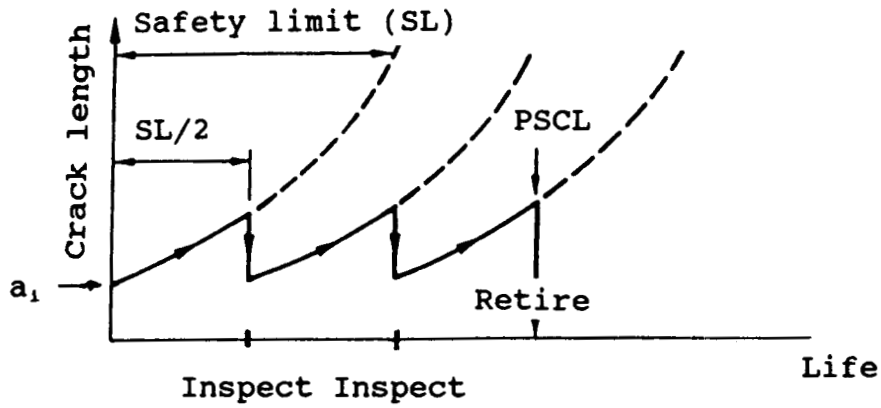

Fig 18 Schematic representation of combined Damage Tolerant-Predicted Safe Cyclic Life

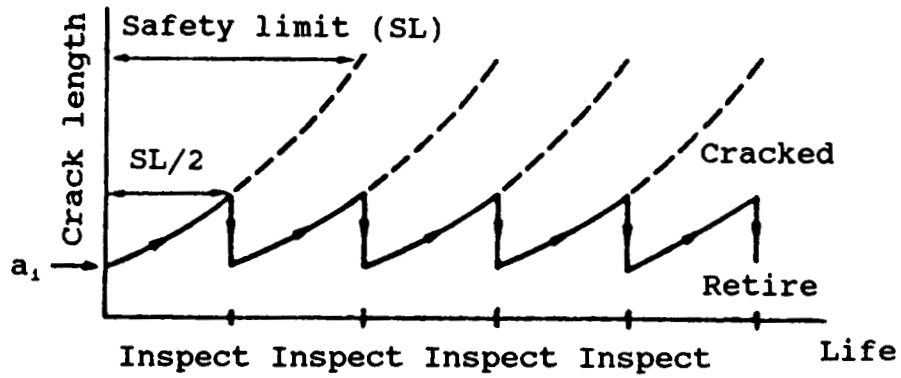

Fig 19 Schematic representation of Retirement for Cause inspection intervals

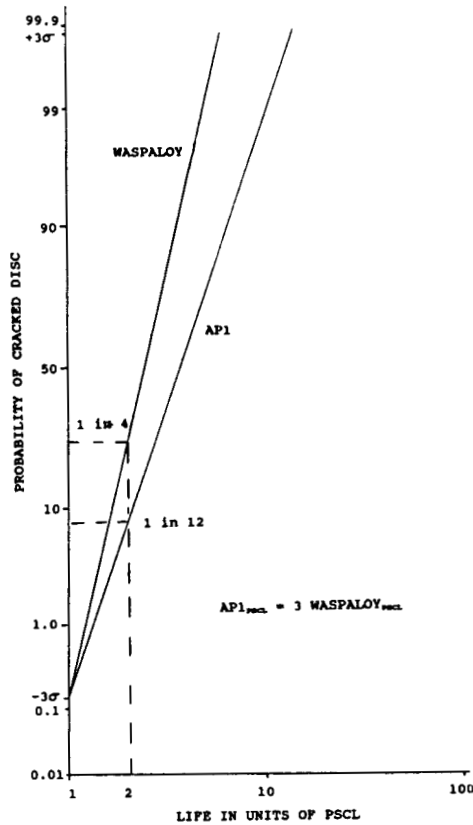

Fig 20 Comparison of Cumulative failure probabilities for Waspaloy and AP1 plotted in units of PSCL

TURBINE DISKS: LIFING AGAINST DEFECTS AND MATERIALS DEVELOPMENT

E. CAMPO, G. PASQUERO
 FiatAvio,
 Corso Ferrucci 112
 Torino (Italy)

A. FREDIANI, R. GALATOLO
 Dipartimento di Ingegneria Aerospaziale
 Via Diotisalvi 2,
 56126 Pisa (Italy)

SUMMARY

Structural integrity of turbine disks must be guaranteed with a high safety level. The Engine Structural Integrity Program as contained in MIL-STD-1783 is aimed to enhance disk safety. A major design requirement is the implementation of the Damage Tolerance concepts by assessing the disk life in presence of defects. This paper illustrates the MIL-STD-1783 impact on turbine design as well as on material requirements, putting more emphasis on induced discontinuity features than on evolutionary ones. Targets for future developments in lifing procedures as well as in innovative materials are defined taking into account possible differences in life management among NATO countries.

1. INTRODUCTION

Aeroengine turbine disks are high speed rotating components whose failure would yield high energy fragments, which are unlikely to be contained by the turbine casing. Since such a failure would constitute a hazard to aircraft safety, turbine disks are classified as fracture critical parts; their structural integrity must be guaranteed with a high global safety level against all possible failure modes. In the design phase the following failure modes are considered:

- High cycle fatigue
- Bursting -
- Low cycle fatigue.

High cycle fatigue due to vibratory stresses is prevented by a design to avoid coincidence between component natural frequencies and the predominant exciting engine orders. Bursting is the failure mode associated with overspeed which raises the component stresses beyond the material tensile strength. Low cycle fatigue is the failure mode associated with the component cumulative damage, due to the operative load spectra application by continuous service usage. Burst and low cycle fatigue requirements have been historically met by the application of design criteria which have limited the component stress levels according to the tensile and low cycle fatigue strength data of the selected material. The continuous development of new materials (fig.1), characterized by better tensile data, has allowed a continuous rise in stress level with a significant weight reduction of the component. This trend has been changed by the Engine Structural Integrity Program (ENSIP) requirements contained in MIL - STD-1783 issued in 1984 [1]. The major ENSIP requirement for fracture critical components is the implementation of the Damage Tolerance (DT)

concepts by assessing the component ability to resist failure due to the presence of flaws, cracks, or other damage for a specified period of usage. This paper aims to show some relevant figures about the impact of ENSIP on turbine disk design and material development, putting more emphasis on induced discontinuity features rather than on evolutionary ones.

2. LIFING: CONCEPTS AND MANAGEMENT

With reference to a component critical area, the cyclic fatigue life is given by the two terms corresponding to crack initiation (N_i) and to crack propagation (N_p):

$$N_t = N_i + N_p.$$

N_i is obtained by laboratory specimen and component cyclic testing up to the onset of engineering cracks, typically not larger than an equivalent 0.75 mm long surface semicircular crack. N_p has to be calculated on the basis of fracture mechanics material data by evaluating the cycles necessary to grow a defect from the initial size up to the critical one. The reliable service life in hours (S) can be established by typical material data taking the scatter factors (γ) and the mission exchange rates (β), both referred to the two fatigue stages, into account:

$$S_t = N_i / (\gamma_i \beta_i) + N_p / (\gamma_p \beta_p)$$

The conventional disk lifing approach considers the first term only and it is universally called Safe Life (SL) method. The innovative ENSIP approach considers the second term only and it is known as the DT approach. The crack initiation scatter factor γ_i is derived on the basis of the 3σ low cycle fatigue data band, where σ is the standard deviation. This band ranges from 10 for conventional materials up to 1000 for high strength powder metallurgy materials. The crack propagation scatter factor γ_p is less sensitive and it can be set equal to 2 for all the materials of interest. The exchange rates β_i and β_p are obtained by engine usage spectra analysis and are also related to the material data, since they represent the damage per mission hour expressed in terms of zero-max reference cycles. The two terms S_i and S_p are alternative terms in the "initial" life release. At the expiry of the initial life the parts can be withdrawn, following the so-called Hard Life (HL) system or the life can be extended by proper Non-Destructive Evaluation (NDE) following the Retirement For Cause (RFC) system. RFC is recommended as a tool to have a better use of the component potential life, by retiring

parts when cracks are actually detected, in contrast to the HL concept where the parts are retired when cracks have a low probability of occurrence. RFC scheme can be implemented within the ENSIP requirements by adding solely N_p terms. The same concept can be applied to conventionally lifed components by adding the N_p to the initial N_i term.

3. INITIAL DEFECT SIZE

The initial defect size is mainly related to the component Non-Destructive Evaluation (NDE) according to the ENSIP. In particular it is recommended that initial design and sizing of components be based on 0.75 mm length surface flaws. In Europe the relationship between initial defect size assumption and NDE capability is not fully accepted: European manufacturers prefer to rely on the material defect size distribution as a result of process, manufacture and handling [2,3].

4. IMPACT OF THE DT REQUIREMENTS ON THE DISK DESIGN

In the following of the paper, the impact of Damage Tolerance requirements on an actual turbine disk design will be illustrated. The relevant figures obtained on a IN718 disk lifed by the SL approach will be compared with those obtained for an Astroloy LC PM disk lifed by the DT approach. The PM material data have been obtained within a Fiat Avio technology program and they are summarized in the figures 2, 3 and 4. Figs. 2, 3 show the typical fatigue data respectively in terms of crack initiation by the traditional S/N curve, and in terms of crack growth versus stress intensity factor range. The inherent defect size distribution, derived by fractographic analysis of low cycle fatigue test specimens, is shown in fig. 4, which can be used to define the initial defect size according to the required remote probability of occurrence. For example, this yields an equivalent radius of 60 microns (European preferred approach). If the initial defect size has to be based on NDE capability according to the present state-of-art, it has to be fixed equal to an equivalent defect radius of 250 microns (USA approach). Fig. 5 compares the stress-cycles design relationships obtained by integrating the crack growth law, starting from the two assumed initial defects, with the similar relationship related to the Safe Life approach, as well as with the IN718 alloy SL curve. It is evident how the Astroloy LC PM allows a significant life increase in respect to the conventional IN718 when the safe life approach is adopted, while a dramatic life reduction arises when the damage tolerant approach is applied. The divarication created by the DT approach is even more significant when the lives are considered in terms of engine operation hours for a given stress level as reported in fig. 6, which shows the results based on an actual engine usage spectrum. The comparison can be done for a given service life and, then, the lifing approach impact is expressed in terms of allowable stress or required weight, as it is shown in Fig. 7.

5. DISCUSSION

The ENSIP requirements have been defined in order to enhance the structural safety level. This enhancement may be expressed for instance

by fig. 8, simply derived from the previous paragraph data, which shows the ratio between SL and DT life as a function of the stress level. It is evident that there is a dramatic reduction in releasable life obtained by the DT approach with respect to the SL one and that this ratio increases for longer lives. It is worth noting how the customer, by requiring a service life, implicitly determines the DT safety factor enhancement. In particular the longer the required life the higher the factor: that is a hard target gives place to an extremely severe safety factor. But safety enhancement has a cost: the previous paragraph data indicate clearly which are the alternative costs related to the damage tolerant application. The new engines designed in compliance with the MIL-STD-1783 have fracture critical parts heavier or with reduced life with respect to the engines developed in the 70ies. Technical literature on DT components has not stressed enough this aspect. An exception is the final discussion of the San Antonio AGARD SMP conference where it has been recorded that "... in designing the first engine to meet full ENSIP requirements, only 191 lbs was added to its weight..." [2]. A weight increase or a reduced life seem paradoxical consequences since there is no reason to develop new engines without challenging the performance data of existing proven safety engines. In order to balance the penalty associated with the damage tolerant requirements, the materials development must occur according to a new trend. The new key factors are fatigue crack growth resistance and defect size control and limitation. Fig. 9 illustrates the theoretical target in terms of cyclic life which should be set in order to keep weight and endurance of a DT disk at the same level of a conventionally lifed IN718 disk. It is evident how Astroloy has no chance to hit the target even improving its cleanliness far beyond the present state-of-art. A maximum initial defect size of 60 microns would require an innovative material with a crack growth resistance 3 times greater than for Astroloy LC PM. If reference is made to NDE capability the crack resistance enhancement should be more than 5. Fig. 10 shows the previous defined targets in comparison with a collection of crack growth data derived from Fiat Avio database and open technical literature [4]. It is evident how, even by taking as reference recent developed materials like N18, the defined targets are hard to achieve since the required further development is about equal to that of the last 10 years. It must be emphasized that the crack growth enhancement targets have been defined within the ENSIP framework. The frame of the present requirements will be overcome when reliable models will be set, able to account for the defect influence on crack initiation and these models will be introduced in the design practice. The new requirements will allow to establish new targets for materials development. A new trend will follow. It is desirable that the continuity with the former material development history will be recovered. The gap between the present best level material (N18) and the required target may be accepted if the RFC is to be implemented. In this case it should be possible an initial life release based on inherent defect size equal to 2/3 of the assumed reference target (SL lifed conventional disk having equal weight) and iterated subsequent release of 1/3 after NDE evaluation. Unfortunately, cost savings obtained by RFC are dependent on the fleet size and in this respect an uneven situation exists among

the NATO countries. The investment necessary to implement RFC gives a questionable profit for most of the NATO countries. Profit figures only become considerable for USAF.

6. CONCLUSIONS

The Damage Tolerance concepts are required by ENSIP to define the lives of the fracture critical parts. This enhances safety but has a negative impact on rotor weight. Further, ENSIP has induced discontinuity in materials development and diversification in life management practices. The materials development targets, in terms of crack growth behaviour, have been set in such a way as to make future aeroengine turbine disks have the same weight and the same life as conventionally designed disks. Despite this "zero advancement" hypothesis the required materials development is quite ambitious, since it implies a crack growth resistance enhancement equivalent to that achieved in the last decade. Damage Tolerance coupled with Retirement For Cause offers potential life cycle cost savings but the investment is such to make it profitable only for Airforces with large fleet sizes. A more advanced lifing approach based on both fatigue stages, by merging crack initiation and crack growth, is highly desirable in order to readdress the present diversified research efforts towards a common philosophy for the benefit of the NATO countries.

REFERENCES

1. Military Standard - Engine structural integrity program (ENSIP). MIL-STD-1783 (USAF). 30 November 1984
2. Damage Tolerance Concepts for Critical Engine Components. AGARD Conference Preceedings No. 393, 1985
3. AGARD/SPM Review. Damage Tolerance for Engine Structures. Report Nos. 768 (1988), 769 (1989), 770 (1990), 773 (1991).
4. Superalloys 1988, Edited by S. Reichman, D.N. Duhl, G. Maurer, S. Antolovich and C. Lund. The Metallurgical Society, 1988

**HISTORICAL TREND
 YIELD STRENGTH/DENSITY**

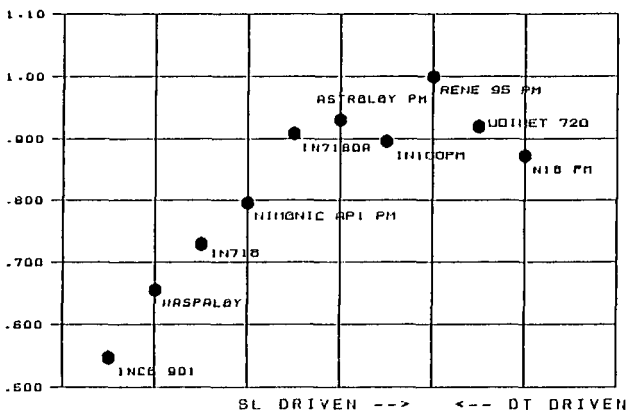

Fig. 1 Development of turbine disk alloys with reference to the specific yield strenght (Fiat data and data from ref. 4).

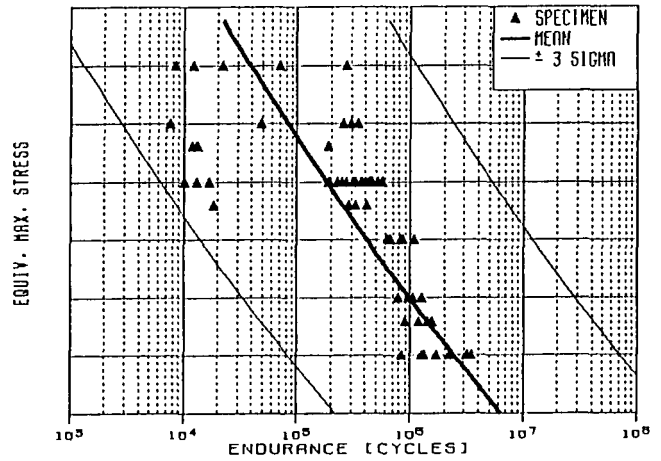

Fig. 2 LCF results obtained on Astroloy LC PM at 500 °C.

CRACK PROPAGATION

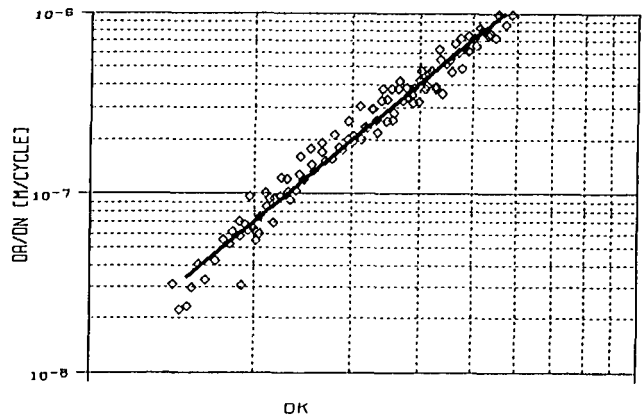

Fig. 3 Crack growth test results obtained on Astroloy LC PM at 500°C and R = 0.1.

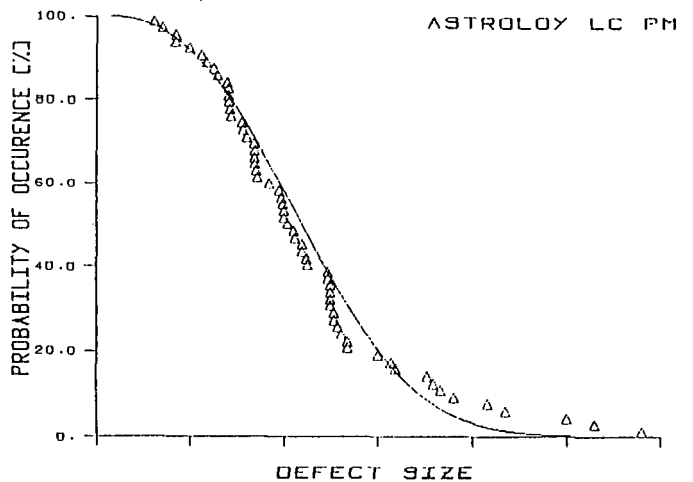

Fig. 4 Statistical distribution of the most severe defect size obtained on Astroloy LC PM

CYCLIC LIFE DESIGN CURVES

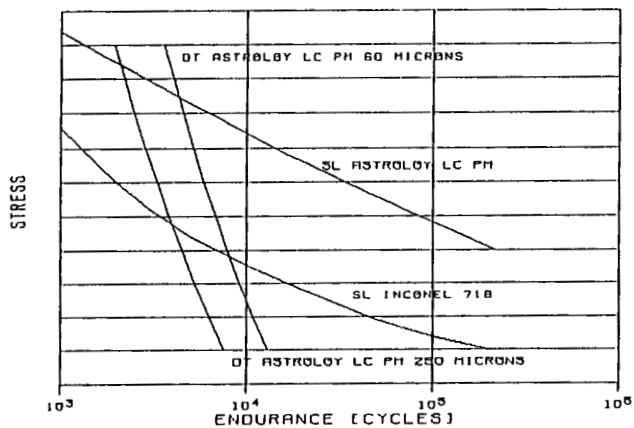

Fig. 5 Summary of LCF design curves for IN718 and Astroloy LC PM

SL/DT 250 MICRON RELATIVE LIFE [HOURS]

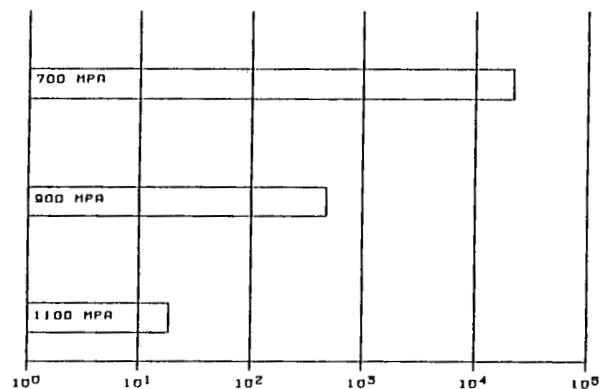

Fig. 8 Influence of the stress level on the ratio between SL and DT life.

RELATIVE LIFE [HOURS]

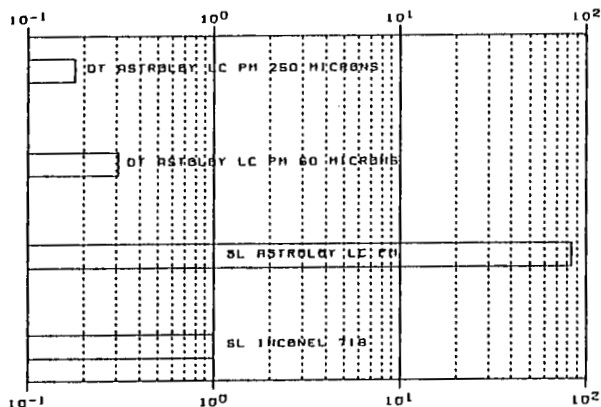

Fig. 6 Impact of lifing approach on the releasable life of an actual disk (geometry as datum).

LIFE TARGET

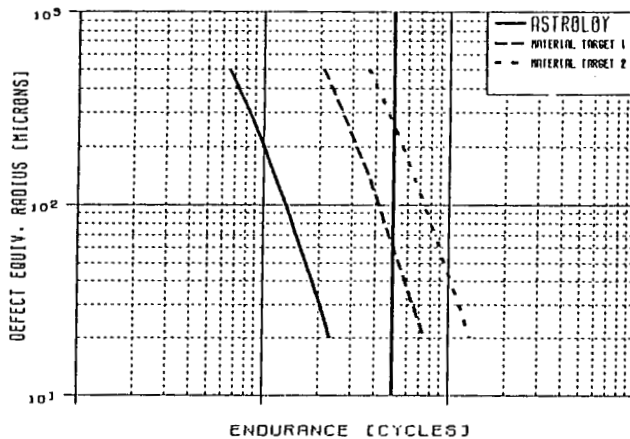

Fig. 9 Cyclic life target for future material development able to keep weight and life of current SL lived conventional disks.

DISC WEIGHT RELATIVE TO INCO 718 (SAME LIFE)

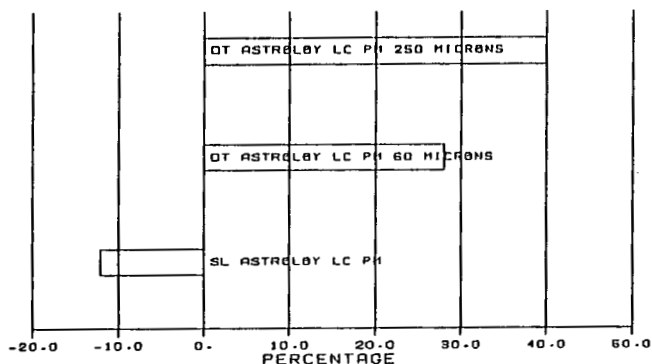

Fig. 7 Impact of lifing approach on the weight of an existing configuration disk (life as datum).

CRACK GROWTH RATE AT FIXED DK AND TEMP.

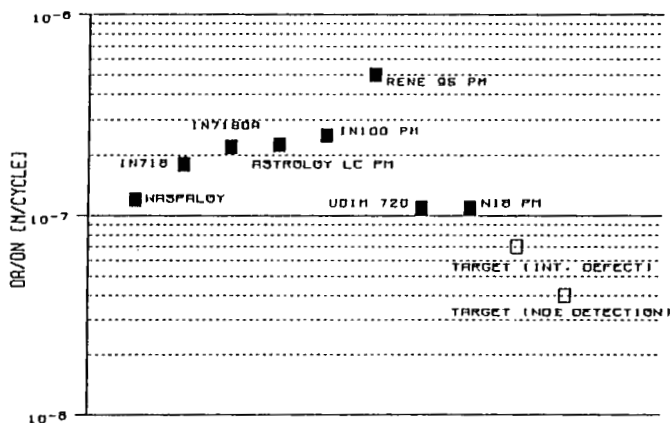

Fig. 10 Historical trend of disk alloy crack growth rates and targets to be assumed for future materials development.

SUBSTANTIATING POWDER METAL LIFE METHODOLOGIES FOR ENGINES

Dr. P.A. Domas
GE Aircraft Engines
General Electric Company
P.O. Box 156301, One Neumann Way, M/Z Q105
Cincinnati, OH 45215-6301, USA

1. ABSTRACT

The application of powder metal (PM) superalloys in aircraft turbine engine rotating components is prompted by performance driven high strength and creep resistance requirements. Fine grain, precipitation strengthened nickel-base alloys such as IN100, Rene'95 and Rene'88DT meet these requirements up to operating temperatures in the 1200-1300F (649-704C) range. In addition to burst and deformation limits, design constraints include durability (fatigue) and damage tolerance (crack growth resistance) capability to insure reliability and safety. Fatigue life for these alloys can be influenced by inhomogeneities (inclusions) intrinsic to the microstructure as the result of processing, and by perturbations of the surface integrity during component manufacture and subsequent usage. Understanding of PM fatigue behavior and substantiation of life assessment methodology must appropriately recognize these potential influences.

New testing, modeling, and analysis schemes are necessitated in engineering development programs addressing generation and validation of life prediction techniques for these materials. This paper outlines one approach to substantiating PM fatigue life prediction that attempts to recognize inhomogeneous fatigue initiation by incorporating probabilistic models and development testing methods that address material volume and component feature effects. Complications and limitations being addressed in ongoing work are discussed.

2. INTRODUCTION

Aircraft turbine engine performance is often measured by thrust to weight ratio. Increased thrust (generally associated with higher turbine operating temperature) and decreased weight (generally associated with use of stronger materials) and hence higher performance result when PM nickel-base superalloy disks are employed, for example. Ultimate tensile strengths over 200 Ksi (220 Mpa) at 1200F (649C) are typical. Unfortunately, these high strengths are generally accompanied by somewhat lowered ductility which can sensitize the material to potential imperfections (e.g. microstructural inclusions, machining scratches, etcetera). An illustration of this tendency is Figure 1, comparing typical PM material relative Ultimate strength (actual Ultimate strength divided by a normalizing value) and corresponding relative elongation to other typical forged disk materials. Further, among current PM microstructural constituents are nonmetallic (e.g. ceramic) inclusions that arise from PM material processing. These can contribute to fatigue failure mechanisms for these materials. The resulting potential inhomogeneous behavior necessitates consideration of the possible need for alternate fatigue life methods and substantiation programs.

3. INHOMOGENEITY - SIZE EFFECT

The potential presence of intrinsic microstructural inclusions and other imperfections such as voids (porosity) can, for some materials, lead to inhomogeneous material properties (size effect). As more material volume is subjected to test, for example, the minimum observed fatigue life will tend to decrease as a more complete sample of the total population of potential inclusions is included in the database, perhaps stabilizing only after a large volume has been tested.

Figure 2 illustrates dependence of fatigue life on inclusion content. Each point represents the result of a nominally identical PM Rene'95, smooth bar, strain controlled, low cycle fatigue test at 1000F (538C). Failure causing fatigue cracks in these bars initiated from ceramic inclusions of various sizes. Resultant lives varied by an order of magnitude. More importantly, within the considerable scatter, there is an apparent trend of reduced life with increased inclusion size. Similar results have been obtained for IN100^[1] where inclusions with area greater than 1×10^{-6} square inches (645 microns²) influenced the fatigue life at 1000F (538C).

While a reasonable theoretical postulate, and indeed evident in specific test data, "size effect" has not been consistently observed in fatigue testing of inclusion containing engine alloys. This is presumably associated, at least in part, to the inability of inclusion area (size) alone to explain the resulting life behavior. Other parameters such as matrix and inclusion mechanical properties and inclusion-matrix interface characteristics for example, in general, appear to contribute to the influence of inclusions.

4. SURFACE INTEGRITY INFLUENCE

Beside the need to appropriately address intrinsic inclusions as potential fatigue crack initiation sites, PM strength and ductility properties lead to a heightened awareness of potential sensitivity to surface anomalies. The relevance of this consideration is illustrated in Figure 3. In this chart, "Full Life" is expected fatigue life based on laboratory smooth bar testing. The vertical axis depicts the percent of full life obtained on PM reduced scale spin pit disks containing design limited features manufactured in several ways. With a nominal machining process, a slight loss in expected life was observed. This could be restored by any of several post processing (surface enhancement) options. Aggressive or abusive (high speed and feed rate) machining significantly reduced the available fatigue life.

Obviously, for any material, life studies relating to the impact of various manufacturing process options, and subsequent lock-in and enforcement of good quality control, are appropriate development steps. Figure 3 illustrates the potential breadth of impact of some of these variables for a PM material.

Having briefly examined these two principal elements of PM behavior, the next section discusses some life prediction method options which address the issues raised. These options range from fairly straightforward extension of conventional methodology to conceptually innovative (and challenging) alternatives.

5. POTENTIAL LIFE PREDICTION METHODOLOGIES

In simple terms, a typical applied fatigue life prediction method seeks to utilize laboratory observations coupled with some set of analysis rules to provide an estimate of component fatigue capability as a function of usage (in-service) environment (stress and temperature).

Without diminishing the significance of the inclusion and surface integrity questions, it is important to note that modern PM alloys are processed, machined, and inspected using the most sophisticated technology and highest quality control standards available to the aerospace industry. These are in fact "very high quality" materials. Observation of fatigue behavior for recent vintage powder materials (derived from cyclic, strain controlled testing of laboratory samples) is, not surprisingly, similar to that of other turbine engine disk materials when viewed on a Strain - Life (S/N) diagram. The question is whether or not there is a difference in the confidence with which one can project future behavior of large (component size) volumes of material based on observation of small volumes (samples) of material.

With reference to the Figure 4 schematic, a host of potential life prediction methodologies can be offered to address observed PM fatigue behavior. Several classes of life prediction methods can be envisioned. In the figure, two somewhat opposed classes are depicted. One termed "Empirical", the other "Probabilistic".

Empirical methods

One class of predictive methods could be considered primarily empirical in nature. Methodologies in this class might include, for example, a design approach that relied on the use of surface enhancement to suppress surface initiation at inclusions and thus assure low life results associated with surface initiation did not occur. In this approach, calculated critical area strain ranges would be used to enter the laboratory specimen S-N curve to obtain estimated available fatigue life. A second approach might employ seeded fatigue bars to generate design limit curves; selecting as the limiting S-N curve that which was seeded with the largest anticipated inclusion.

Such methods are desirable for their simplicity and are representative, essentially, of current conventional material practice. However, this type of approach suffers from lack of certainty as to effectiveness of the surface treatment in the former case and surety of capturing the largest inclusion behavior in the latter. If the method embodies the assumption that inclusions are always present in the critical areas, such as the seeded bar approach, it may be overly conservative as well. Nevertheless, with suitable testing and evaluation, these methods might be viable and well worthy of pursuit.

Probabilistic methods

Another class of methods is more analytic and could be considered probability based. These methods explicitly recognize the potential inclusion influence. They attempt to account for this

through probabilistic representation of the likelihood of inclusion occurrence in a critical area and variability in inclusion size and behavior. Among this class of methods, a comprehensive probabilistic methodology that includes the probability of: inclusion occurrence, inclusion size, cycles to initiation, cycles of propagation, etcetera could be used. This has the advantage of analytically estimating survival probability thus enabling explicit risk assessment and management. However, it has a significant disadvantage of requiring complete characterization of the inclusion size and nocivity (degree of "crack-like" behavior) distributions.

In addition, an issue arises for industry and regulatory agencies in defining appropriate risk levels for design limits. The apparent legal tenet that machines operate without risk of failure and presence of risk (or even a risk assessment calculation) implies "fault" or "error", is an unfortunate and incorrect paradigm significantly hindering general application of these methods.

Returning to Figure 4, a second potential method in this class is less rigorous but more readily applied. In this method, a limiting (remote) inclusion size is assumed to pre-exist in component critical locations. A limiting component life would then be defined based on predicted life (including perhaps crack initiation as well as crack propagation life) for this inclusion, in the unlikely event it were to actually occur. A potential advantage in this method is that the inclusion distribution does not have to be as completely defined since a limiting flaw size, perhaps somewhat arbitrarily chosen, is controlling. A pitfall is the false perception that risk assessment is no longer involved. A survival probability is associated with this calculation although it is now implicit. Further, if it is desired to utilize the "true" limiting inclusion size, if one exists, the same difficulty in obtaining a complete inclusion distribution returns.

A probability based method is appealing in that it has the capability to incorporate the inclusion information available from sampling of raw powder and to recognize in a quantitative fashion the variability, and risk associated with potential behavior. Also field experience, both positive and negative, can be used to calibrate distributions and provide a link between analysis and real world observation. Such methods lend themselves to addressing the broader issue of overall variability in engine component design. In fact there is ongoing US Air Force sponsored work to develop a Probabilistic Rotor Design System^[2,3].

"Holistic" approach to life assessment

Conceptually the evolving methodologies may ultimately be merged into what might be termed a Holistic Life Assessment approach as shown schematically in Figure 5. Design (component size, basic contour, rough features) would be on a deterministic basis. Average mechanical properties would establish component strength, fatigue, and damage tolerance capability and determine potential fracture criticality. Variabilities in the different properties, geometries, usage, etcetera would be input to a probabilistic assessment to determine potential sensitivities to various parameters. The final design would emerge from iterations to balance sensitivity and capability.

Variations of these and other methodologies are possible. The selection of a particular approach depends on the type, quantity, and quality of data that can be obtained; specific material behavior;

component criticality; and confidence level. Whatever method is selected, some form of verification or substantiation will be required. Part of that verification can come from the predictability of the design database (standard fatigue test specimens) but part must come from other sources in order to increase the volume of material evaluated and more realistically represent actual usage environment.

In pursuing the probabilistic class of methods further, the following considerations arise.

6. MATERIAL BEHAVIOR ASSESSMENT

For material behavior governed by homogeneous microstructure it is anticipated that a fairly comprehensive assessment of expected fatigue behavior can be obtained from a modest amount of material testing. Laboratory tests on relatively small fatigue bars sampled from several heats of material suffice to generate a stress versus fatigue life curve with reasonable confidence. However, even for nominally homogeneous material, Roth^[4], in discussion of competition in probabilistic analysis, has demonstrated sampling variability and part-to-part variability can lead to differences in observed fatigue capability. This concept of competition is also important in attempts to generate inclusion distributions using observations from fatigue test samples as will be discussed later.

Having recognized the presence of inclusions may lead to somewhat more heterogeneous fatigue behavior for powder metals, consideration for a more encompassing material testing plan emerges. Larger volumes of material (larger size or greater quantities of test specimens) should be sampled. The sample should be of sufficient size to capture a true representation of the material behavior.

When the occurrence rate of imperfections of importance (sufficiently large to significantly influence fatigue life) is low, the requisite volume of material necessary to capture a representative sample can become prohibitively large.

Fractography of fatigue and tensile test specimens

Faced with this need to test impractical quantities of material to empirically assess behavior, one can look more closely at the characteristics of the failed fatigue or tensile test specimens in hand. By inquiring as to the root cause for each failure, trends may be revealed that allow projection of future test outcomes based on observations to date. Coupled with the potential ability to use a statistical inclusion distribution to estimate life, this leads rather naturally to the use of failed test bar fractography as a means of sampling inclusion content.

Fractured laboratory tensile and/or fatigue test samples are microscopically examined for fatigue origins. Inclusion origins are recorded as to type, location, and size (area). These data provide an estimate of the material inclusion size distribution for use in probabilistic analysis.

A complication that arises from employing fatigue and tensile test results is an apparent censoring (masking) of the results that occur. Such tests are run at particular stress and temperature conditions on test bars of particular geometry and with varying degrees of surface residual stress, having been cut from forged components of varying size and shape. Roth^[4] has pointed to a competition taking place

in such tests and has shown that distributions derived from them can be misleading.

Direct assessment of powder cleanliness

Instead of examining failed test bars to arrive at inclusion distributions one can directly examine the powder product before consolidation using various inclusion separation methods. This is much preferred in that it avoids the censoring inherent with the other method. However, it results in observation of inclusions in a form prior to final forging, extruding, etcetera which may also lead to uncertainty in accuracy of the distribution for use in final life prediction.

Use of seeded test specimens

Having sampled the material in some fashion and obtained an inclusion size distribution, it remains to determine the impact of the inclusions on fatigue life.

With sufficiently high occurrence rates this behavior may be discernible from the laboratory bar fatigue database. More likely, only an indication of inclusion behavior will be obtained from that source since only a fraction of the test bars will initiate at an inclusions. Generally, most of the data will involve average inclusion sizes rather than the larger (design limiting) sizes of interest. An alternative is to employ seeded samples. Fatigue testing material known to contain a representative distribution of inclusion sizes or a specific size of interest (e.g. an extreme value) to validate behavior is as predicted or is bounded by the prediction methodology. Roth^[4] has shown for example that seeding studies in PM Rene '95 could validate probabilistic methods and demonstrate influence of other phenomenon such as natural fatigue sites. Figure 6^[4] illustrates successful life prediction of seeded PM alloy bars using the GE Aircraft Engines probabilistic life code MISSYDD (MISsion SYnthesis given Defect Distribution). A confident life assessment and validation program relies on appropriately defined material behavior. In general, all these elements: fractography of failed test pieces, powder cleanliness assessment, and behavior of seeded material will contribute to the requisite understanding and should be embodied in a powder lifing method validation effort.

7. COMPREHENSIVE SUBSTANTIATION APPROACH

A comprehensive substantiation of a probabilistic life method for a PM material goes well beyond historical practice. This is illustrated in the Figure 7 schematic. Historically, for conventionally forged disk materials, a confident laboratory fatigue curve supplemented by prior experience and component test correlations could verify a life prediction method. For the PM materials and the probabilistic method, new information needs to be incorporated. The inclusion distribution comes from the powder assessment and/or the smooth bar data base. To assess occurrence rate and critical volume scaling concepts, as well as surface integrity questions, reduced scale disks can be used. An example disk is sketched in Figure 3. Such tests facilitate bringing together stress analysis methods, realistic design geometries, realistic (e.g. multi-axial) stress fields, actual machining practice, more representative material volumes, and material behavior in one comparatively economic test vehicle. Finally, companion testing in material purposely seeded with known inclusion distributions provides comparison of behavior when inclusions are present

versus that when they may be present, enabling determination of inclusion tendency to behave as a crack, for example.

8. COMPLICATIONS AND LIMITATIONS

Perhaps the biggest complication for the probabilistic class of methods is the need for an inclusion distribution. Obtaining such distributions has proven to be extremely difficult and expensive. Understanding of observed differences between distributions obtained from tensile tests, fatigue tests, and raw powder cleanliness measurements is improved over the past but remains limited. Fortunately there has been considerable progress in developing production techniques for surveying powder cleanliness at supplier facilities that can potentially be used in statistical process control systems. While this somewhat facilitates obtaining distributions, their accuracy and viability will no doubt remain a major issue for these methods for some time.

Another important question is the severity or nocivity of specific inclusions. Are they benign or do they lead to early crack initiation? Simplistic models would hope to relate behavior to inclusion size alone. Below a certain size the inclusions are ineffective, above a certain size they behave as sharp cracks, perhaps, and could be treated using fracture mechanics. Experimental studies are revealing that parameters other than size are important. Among them temperature, stress, and inclusion location (surface or subsurface). Until this behavior is better understood empirical data and engineering interpolations will have to be employed.

Finally, less technical, but nonetheless vitally important to application of these approaches is the issue of appropriate risk. The quantification provided by probabilistic analyses is valuable and useful to the analyst. On the other hand the concepts of "risk" and "probability of failure" are currently incompatible with regulatory agency and general society visions of safety and reliability. A common standard of acceptance of appropriate risk levels is needed, or if it exists, it must be more widely disseminated and accepted by the populace if such life estimation methods are to become commonplace.

9. SUMMARY

The nature of PM nickel-base superalloys leads to their highly suited application in gas turbine engine components. High strength, uniform grain size, freedom from chemical segregation, high cleanliness, and excellent ultrasonic inspectability can be achieved. Characteristics that lead to these attributes also necessitate evaluation of the possible need for an alternative fatigue life prediction methodology and a more comprehensive method substantiation program. High strength, lessened damage tolerance potential in certain regimes, inherent inclusions and demanding machining requirements suggest probabilistic modeling and representative geometry testing as potential elements of such a methodology. Tests of fatigue bars and reduced scale disks (seeded and not seeded) can be used to validate the modeling, leading to confident design, manufacture and utilization. However, complexities in defining a confident inclusion size distribution, characterizing inclusion severity, and even the suitability of explicitly employing risk analysis in engine life prediction, present significant challenges that are being addressed.

10. REFERENCES

1. Annis, C.G., Mills, M.S., and Harris, J.A., "Engine Component Retirement for Cause, Volume II, Life Assessment Systems Development," AFWAL-TR-87-4069, August 1987.
2. Coomer, J.T., and Roth, P.G., "Probabilistic Rotor Design System (PRDS)," USAF Contract F33615-90-C-2070, work in progress, December 1991.
3. Roth, P.G., "Probabilistic Design - Philosophy for Implementation," presented at 1991 USAF Structural Integrity Program Conference, San Antonio, Texas, December 1991.
4. Roth, P.G., "Competition in Probabilistic Life Analysis," in Proceedings of the 1990 USAF Structural Integrity Program Conference, WL-TR-91-4067, August 1991.

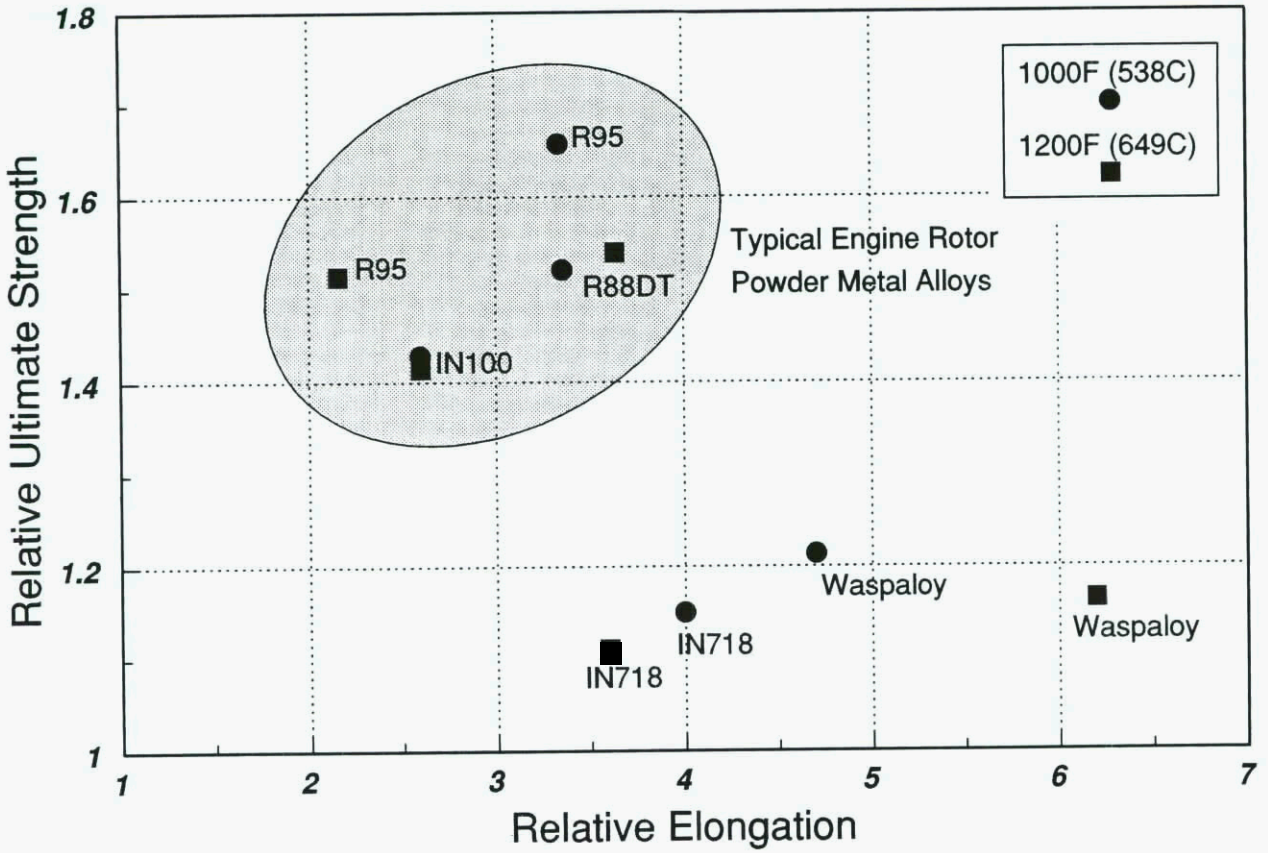

Figure 1. Relative strength and ductility Comparison.

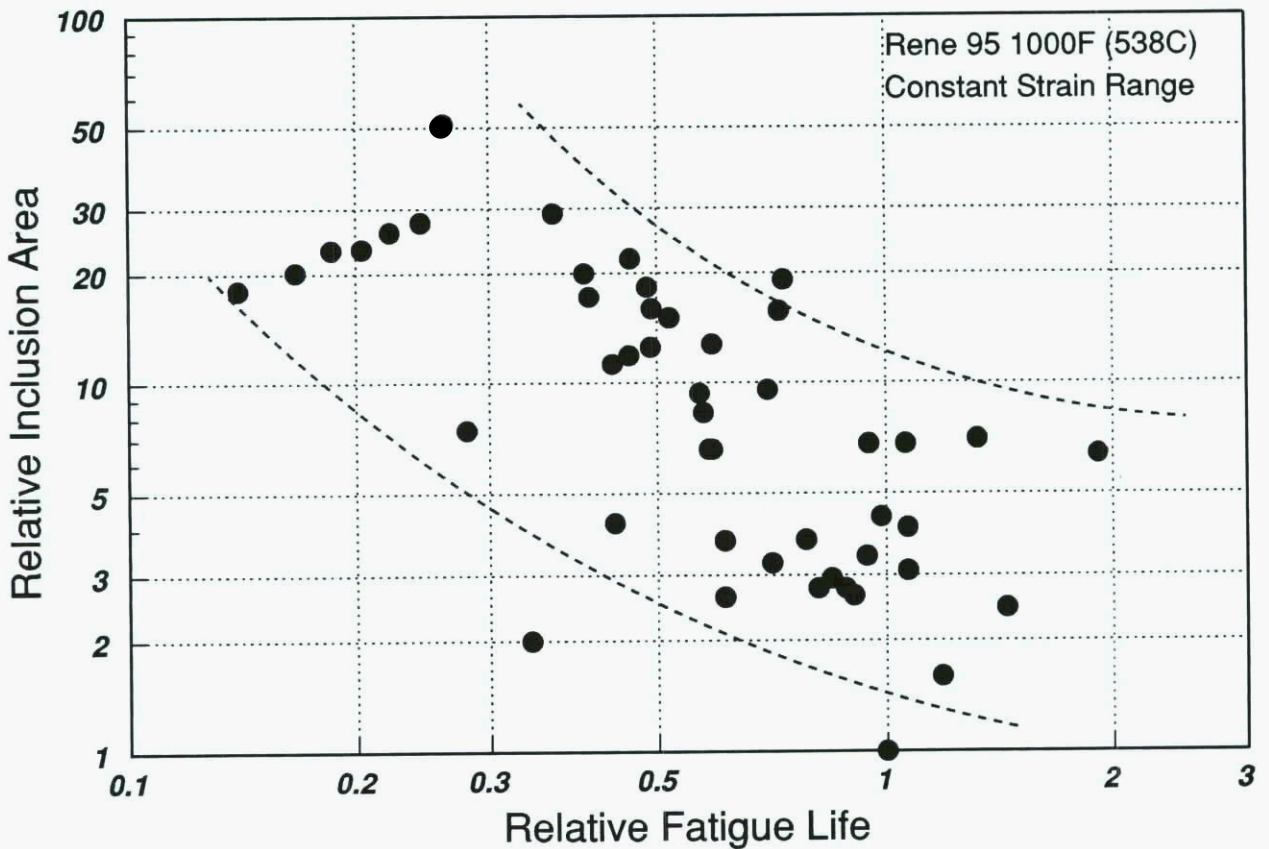

Figure 2. Fatigue life is a function of inclusion content.

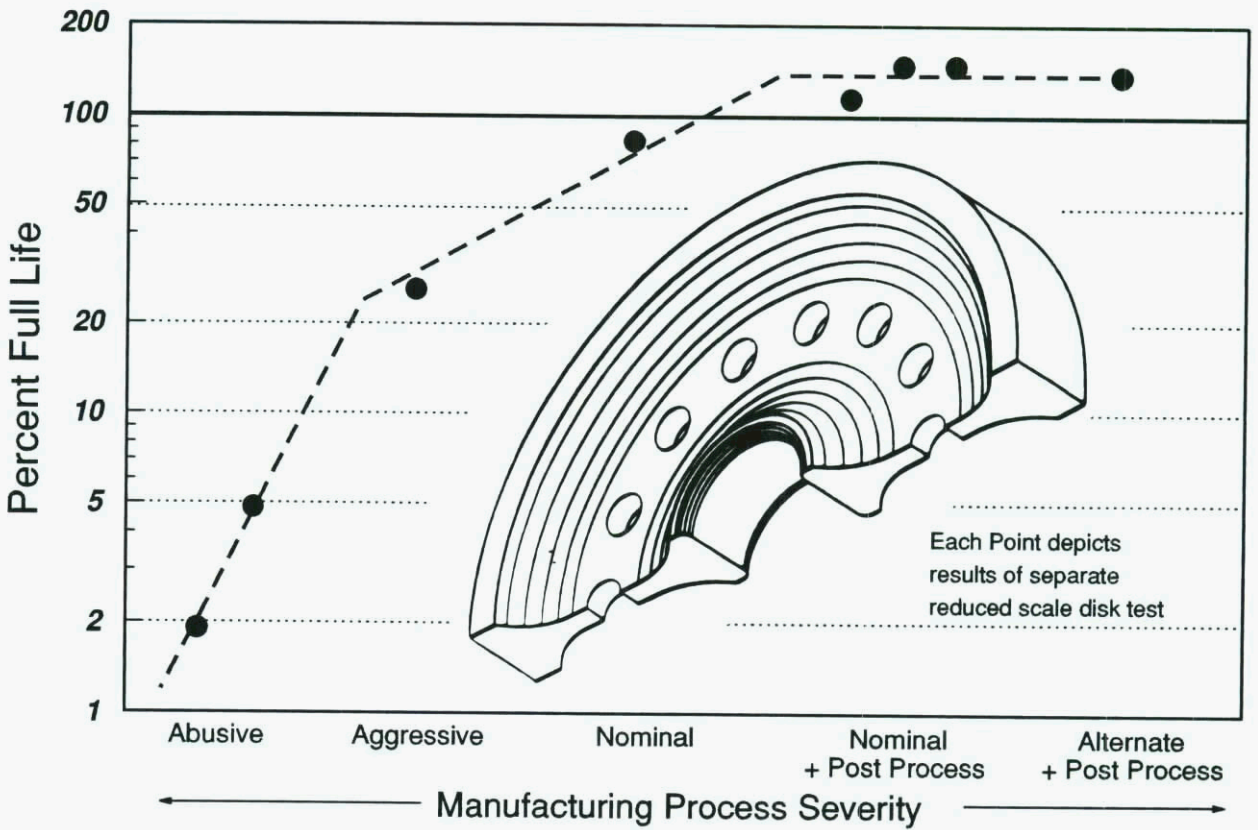

Figure 3. Example testing for processing substantiation. Nickel-base powder alloy, reduced scale disks.

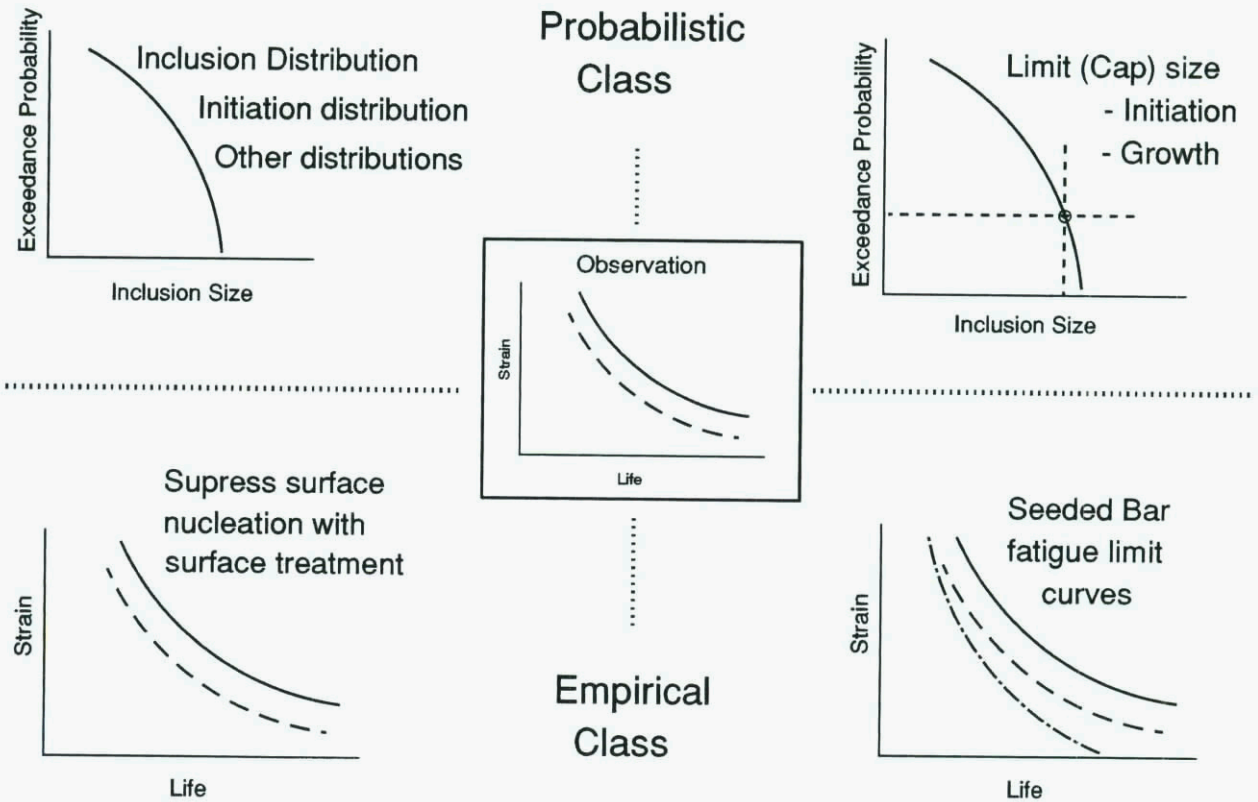

Figure 4. There are a multitude of potential life prediction methods.

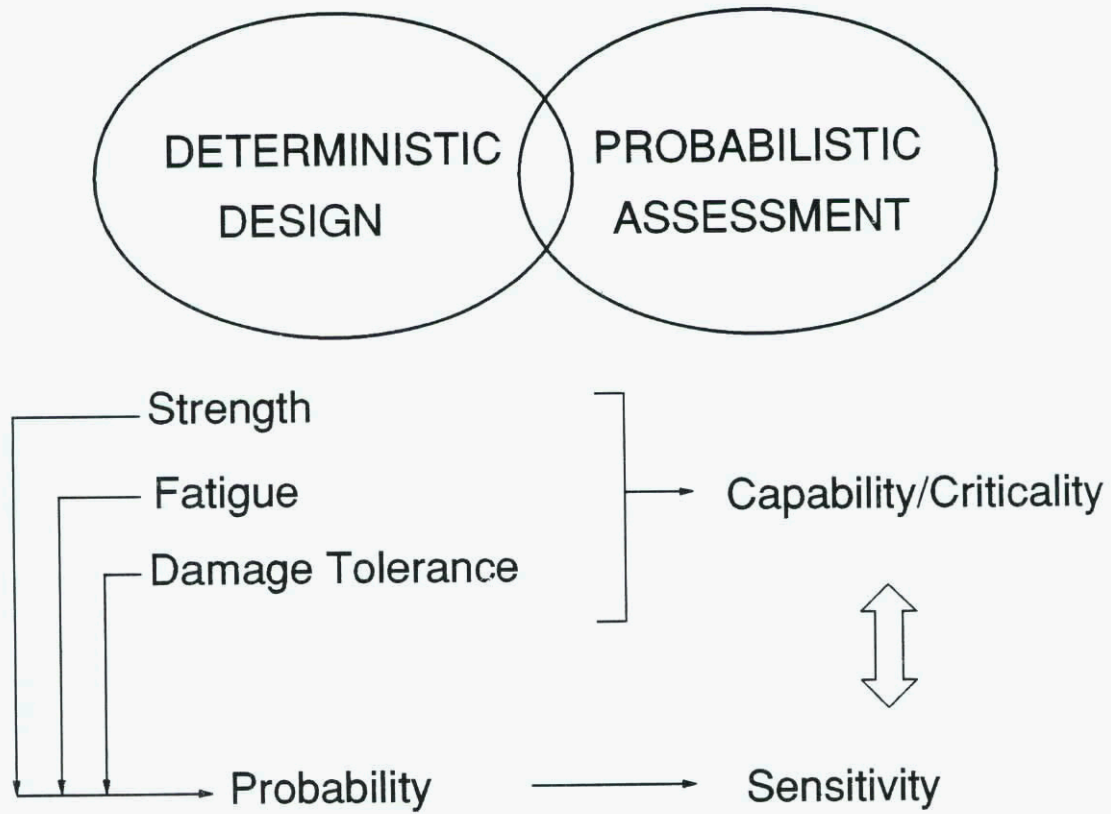

Figure 5. An "Holistic" approach to life assessment is preferred.

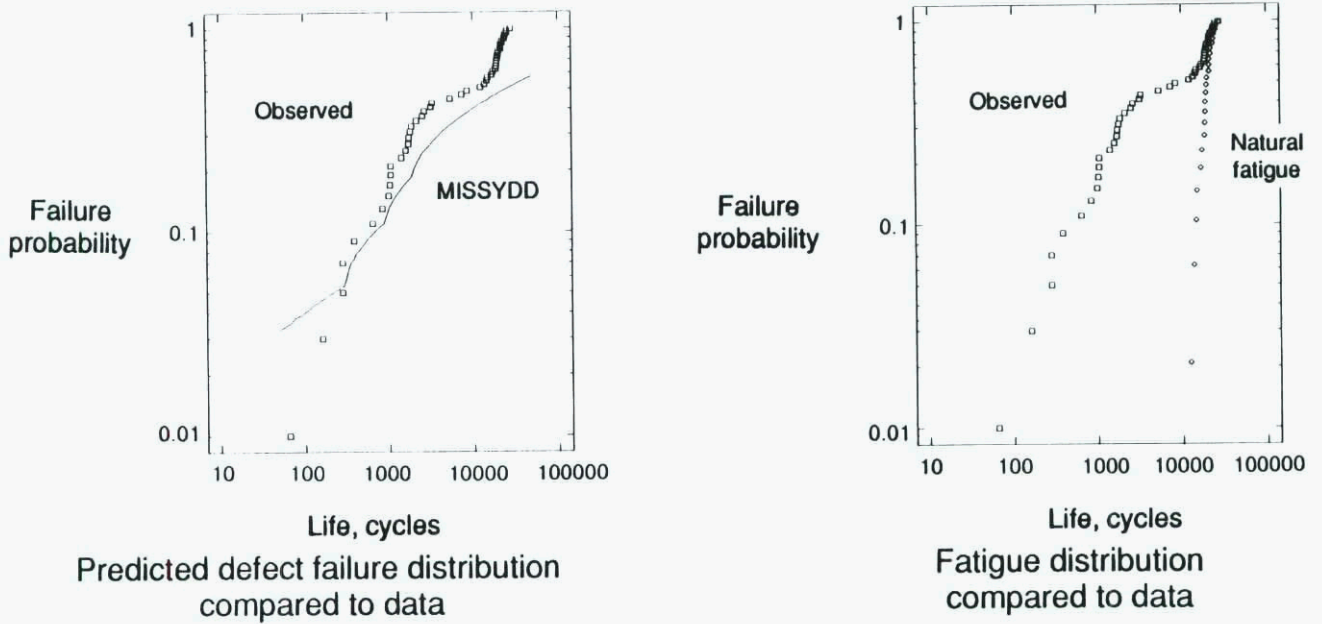

Figure 6. Successful probabilistic life prediction of seeded PM alloy test bars using MISSYDD computer code.

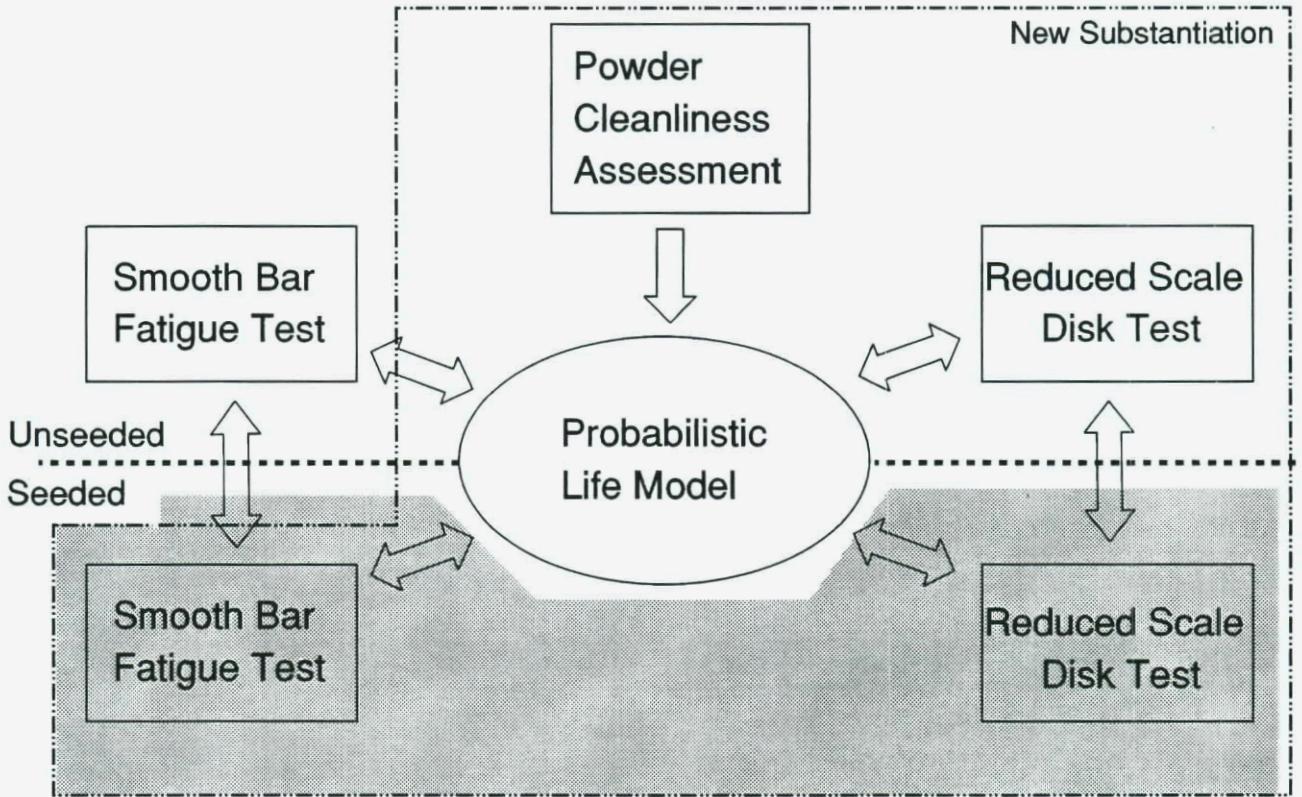

Figure 7. A strategy for substantiating powder metal life methodology.

PREDICTING DEFECT BEHAVIOUR

by

G.W. König* and J.W. Bergmann**

*MTU Motoren- und Turbinen-Union, Deutsche Aerospace, Dachauer Str. 665, W-8000 München 50

**IABG Industrieanlagen-Betriebsgesellschaft mbH, Einsteinstr. 20, W-8012 Ottobrunn, Germany

1. INTRODUCTION

Material defects have a tremendous effect on the fatigue life of engine components. The reason for this is that fatigue properties are determined by the "weakest element" rather than by the average strength of the material. This is readily demonstrated by many component tests. As an example Fig. 1 shows the results of a cyclic spinning test performed on a PM nickel-base turbine disc [1]. The total number of cycles was 11.225. At the end of this test a single crack was found in the disc bore. SEM investigations of the fracture surface revealed a nonmetallic inclusion (aluminium oxide) of approx. 50 micron diameter at the crack origin. In the remaining bore area no other fatigue crack could be detected. From the failure analysis it is evident that the fatigue life of the material at the crack origin is substantially reduced by the influence of the inclusion as compared to the (defect free) surrounding material.

This example demonstrates the importance of defects on the fatigue life of components and emphasizes the need for design tools to predict defect behaviour in components. Important questions regarding defect behaviour are:

- What are the types and density of fatigue relevant defects?
- What is the effect of size, shape and type of defects on fatigue life?
- What is the effect of loading conditions (strain range, temperature, load sequence) on defect severity?
- What is the effect of defect location?
- How is the effect of defects influenced by surface conditions (residual stresses)?

2. METHODOLOGY

Fatigue is a statistical phenomenon with contributing factors which are statistical in nature too. Therefore probabilistic lifing concepts appear to be appropriate (Fig. 2, [2]). Major components of any probabilistic lifing concept are:

- microstructural characterization
- load history
- material behaviour

The results of any lifing model can only be as significant as the input data. This paper reviews some important aspects regarding input data which are necessary for the prediction of defect behaviour by probabilistic models.

3. IMPORTANT INPUT DATA OF PROBABILISTIC MODELS

3.1 Materials defect characterization and quantitative description

The starting point of any defect characterization is a list of potentially harmful defects. This information can be obtained from fractographic observations of both component and specimen tests. These tests give information on the "weakest element" in the total volume of the test piece (as in the example shown above).

In a European collaborative COST programme [4] the benefits and disadvantages of different methods (optical microscopy on metallographic sections, electrochemical dissolution followed by a residue analysis, elutriation, electron beam melting, SEM analysis of crack origins) to evaluate defect densities in nickel-

base disc alloys (IN718 and U700 PM) were evaluated for following defect types:

- carbides
- carbo-nitrides
- oxides

Fig. 3 shows a comparison of these defects in terms of defect density vs. defect size as determined by quantitative metallography. This approach was used to assess the effect of different manufacturing routes of IN718 (VIM/ESR, VIM/VAR, VIM/EBCHR, PM/EXTRUSION) on defect distributions and hence fatigue behaviour.

A major problem in material characterization is the determination of low density defects. Most metallographic methods only consider a volume of the material which is small in comparison with the volume of full scale components. Related to the volume of metallographic investigated material there is a boundary below which no information on defects densities can be obtained (Fig. 3.) Nevertheless, defect densities give a good measure of material quality and a good basis for the ranking of materials, manufacturing routes and thermomechanical processing. For the estimation of life relevant low density defects, however, extrapolations relying on assumptions are necessary.

3.2 Material behaviour

Generally defects act as stress raisers resulting in plastic strain concentrations and early crack initiation. To quantify the effect of defects on fatigue life specimens containing artificial defects of definite type, size and shape have turned out to be very useful. The following results were largely obtained from a national German government funded "Materialforschungsprogramm" [3], in which a probabilistic lifing model has been developed. In the experimental part of this programme, the effect of aluminium oxide nonmetallic inclusion on the fatigue behaviour of the PM nickel-base alloy U700 was investigated including three different classes of defect sizes:

- undoped (inclusion size less than 20 micron)
- doped with dia. 50 and 100 micron particles (the related low and upper mesh sizes were 45/53 and 90/104 microns, resp.).

From this programme the following main observations of defect behaviour were obtained:

3.2.1 Effect of defect size on fatigue life

a) Comparison of specimen and component behaviour

Fig. 4 shows the number of cycles to failure as a function of strain range for doped and undoped plain specimens at 400 °C. With increasing defect size the fatigue life is considerably reduced. The life reduction decreases with increasing strain range. The slope of the life curves for the doped materials is steeper than for the undoped one. This means that the improvement of fatigue life by stress reduction is less effective in defective material than in "defect free" standard material.

Doped material data give relevant information for the prediction of component behaviour. Fig. 5 depicts the relation between the defect size and the number of cycles for the temperature and strain range of the crack initiation area of the bore crack shown in Fig. 1. The fatigue life of the bore crack is reasonably close to the corresponding doped specimen data. The fatigue life of the "defect free" material is more than an order of magnitude higher

than that for a 50 micron defect material. This explains the fact that no further cracks were produced in the disc bore (the density of 50-micron surface defects is less than 1 defect/bore area on an average).

b) Crack initiation behaviour

The total fatigue life consists of the regime of crack initiation and propagation. Since the main effect of defects is to be expected on fatigue initiation life special emphasis was put on the experimental determination of crack initiation behaviour. This was carried out by applying a marker load technique [5] which turned out to be much more sensitive and accurate to monitor short crack growth than the conventional alternative standard methods such as potential drop or replica.

With the marker load technique it is possible to monitor microcrack initiation and propagation in the very early stage of fatigue crack growth. Fig. 6 illustrates crack initiation and propagation at a non-metallic inclusion in life increments of 1000 cycles. In the early stage, microcracks develop at different locations of the inclusion. With increasing crack size these microcracks coalesce to a macrocrack which finally propagates as a semi-elliptical surface crack until fracture of the specimen. This example also demonstrates the potential of markerload technique to monitor subsurface crack growth.

In the test documented in Fig. 6 microcrack initiation started at the very beginning of the test. Nevertheless the effectiveness of the defect is less than that of a crack of the same size since various microcracks had to coalesce before a macrocrack was formed.

This is also reflected by crack growth behaviour. The crack growth rate of a microcrack starting from an inclusion is considerably reduced compared to a "natural" surface crack of the same depth, Fig. 7. This suggests that the severity of the inclusion is markedly less than of a crack of the same size and shape. The microcrack at the inclusion behaves similarly to a surface crack of the same absolute size (measured from the inclusion surface). When the microcrack grows to about twice the inclusion size, however, the influence of the inclusion vanishes and the crack growth rate becomes the same as for a "natural" surface crack.

The reduced crack growth rate in the vicinity of an inclusion macroscopically appears as an "incubation period". Here the incubation life is defined as the excess life to the pure crack propagation life starting from a crack of equal size as the defect (defect = crack; see Fig. 8). Fig. 9 shows a plot of the relation between strain range and incubation life. At high strain ranges the incubation life is equal to zero: Under these conditions a pure fracture mechanics life approach is applicable assuming the equivalence between defect and crack. The replica micrographs in Fig. 10 represent a crack of this category. With decreasing strain range (at a level corresponding roughly to the yield stress of the material) incubation life strongly increases. In this range even defective material has a considerable incubation period. At low strains fatigue cracks do not initiate at inclusions (see Fig. 11 which shows an evaluation of the probability of crack initiation at nucleation as a function of maximum strain). Exceeding the monotonic yield strain results in probabilities higher than 50 %.

c) Threshold for defect severity

A question of considerable practical importance is that about the minimum crack size leading to life reduction: From Fig. 4 it is evident that decreasing defect size increases fatigue life. The question is whether there is a defect size where further reduction no longer results in life benefits. Fig. 12 shows the relationship between strain range and defect size for a constant fatigue life of 20000 cycles, derived from Fig. 4. The extrapolation to the strain

level of the "defect free" material gives a threshold defect size of approx. 17 micron.

Possible underlying mechanisms of a minimum defect size for life reduction are:

- Competing other inhomogeneities

If the size of one defect type is reduced other types of inhomogeneities may become life relevant. It is frequently found that the "natural" defect size of a material has the order of magnitude of a "microstructural unit" which in many cases correlates with the grain size. The investigated material has a grain size of about 7 micron. Thus a threshold of roughly twice that size (17 micron) seems to be reasonable.

- threshold of fatigue crack growth

The short crack fatigue crack threshold of this material was found to be about $4.6 \text{ MPa} \sqrt{\text{m}}$ [6]. This gives a "threshold crack size" of approximately 15 micron for the loading conditions of Fig. 12 which is close to the extrapolated crack size of 17 micron.

3.2.2 Defect location

Internal defects are less detrimental than surface or near-surface defects. For a given defect size the advantage in fatigue life of internal defects is often found to be more than a factor of ten. This is also supported by results of component tests: Spinning tests performed on doped discs revealed hundreds of (surface bore) cracks but no evidence of life relevant internal cracks (in spite of the fact that for statistical reasons the number of internal defects in severely loaded areas is considerably higher than on the surface).

There are a number of reasons for the different behaviour of internal and surface defects:

- Internal defects in the crack initiation and early propagation phase are not exposed to the environment. Since oxidation enhances both crack initiation and propagation (Fig. 13) surface defects affect more the fatigue life than internal ones.
- The initial stress intensity for a defect of a given size is less in the interior than on the surface.

3.2.3 Defect density

Since fatigue is a "weakest element" phenomenon the fatigue life is determined by the most detrimental single defect and not by the defect density. Indeed, doped and undoped specimens with cracks starting from defects of equal size have about the same fatigue strength in spite of a factor of 10000 between the defect densities of both materials. However, this statement has following exceptions:

- In a medium loading range the efficiency of defects for crack nucleation is statistically distributed, i.e. only a fraction of defects acts as crack starters while others are completely inactive (see Fig. 11). Therefore, increasing defect density (moderately) reduces fatigue life (at least under certain loading conditions).
- With increasing defect density the probability of crack interaction increases (Fig. 14). The coalescence of two adjacent cracks increases the crack size and results in a reduced crack propagation life compared to single cracks. In advanced clean disc materials interaction of large defects is a very rare event which for many application must not be considered in design.

3.2.4 Residual stresses

In chapter 3.2.1 it has been demonstrated that in nickel-base alloys surface and subsurface is the most detrimental location for defects. It therefore seems promising to reduce the effect of defects by compressive residual surface stresses. The typical depth of compressive residual stresses by shot peening is about 100 microns which is about the upper limit of the defect size of

nonmetallic inclusions in modern PM disc alloys. The beneficial effect of shot peening can be confirmed on doped round bar specimens (Fig. 15). At intermediate strain ranges the fatigue life of doped specimens was increased up to a factor of ten by shot peening as a result of delayed crack nucleation (Fig. 9) as well as of smaller crack growth rates. The beneficial effect of shot peening disappears both at low and high strain ranges: At high strain ranges crack initiation occurs immediately independent of the presence of compressive stresses. At low strain rates crack initiation occurs mainly in the bulk; thus fatigue life tends to be independent of the surface condition. In notched areas with high stress gradients the advantageous effect of shot peening is of course more pronounced.

3.2.5 Load sequence

The results presented so far are related to constant amplitude loading. Under these conditions fatigue life is reduced by more than a factor of ten by the influence of small inclusions. In order to investigate the material under more realistic load conditions, strain controlled tests on smooth specimens were conducted using Cold TURBISTAN, a standardized load sequence for compressor discs [7, 8]. The life reduction by defects is even stronger for a realistic load sequence, Fig. 16. The reason is that the minor cycles in the load sequence strongly decrease crack propagation life but only moderately decrease crack initiation life. Since defective material has a higher percentage of crack propagation phase than "defect free" material, the life reduction is more pronounced in the defective material.

Life predictions have been made according to the local strain approach using two different damage parameters. The parameter after Smith, Watson and Topper only takes into account mean stress effects, $P_{WST} = (\sigma_{max} \cdot \epsilon_p \cdot E)^{0.5}$. The parameter P_f [9], derived from fractures mechanics, assumes a crack from the beginning of life, takes into account crack closure effects, mean stress and a damage dependent drop of the endurance limit during life. The comparison of experimental and predicted lives shows that P_f is more conservative than P_{WST} and meets the experimental results better in an overall view.

4. SUMMARY AND CONCLUSIONS

1. Material defects up to 100 microns in size considerably reduce the fatigue life of critical engine components.
2. Probabilistic models which may contribute important input to forthcoming design concepts, require input data on microstructural material characterization, material behaviour and load history.
3. A number of examples of defect characterization and material/defect behaviour in nickel-base alloys is given including results of specimen and component tests as well as of standard and doped powdermetallurgical materials.
4. The capabilities of life prediction is assessed on the basis of
 - comparison of specimen and component behaviour
 - prediction of mission fatigue (Cold TURBISTAN) based on constant amplitude load test results.

5. REFERENCES

- [1] H.Huff and G.W. König.:
 "Evaluation of Cyclic Spin Pit Tests for the Damage Tolerance of Discs"
 AGARD Meeting "Damage Tolerance Concepts for Critical Engine Components", AGARD-CP 393
- [2] H. Fischmeister, U. Quadfasel, V. Banhardt, A. Brückner-Foit, H. Jäckels, P. Eßlinger, G. König
 "Auf dem Weg zu einem probabilistischen Lebensdauermodell für Flugturbinen-Scheiben"
 Zeitschrift für Metallkunde, Bd. 81, 707-714, 1990
- [3] Materialforschungsprogramm "Entwicklung eines strukturabhängigen Werkstoffmodells für komplexe Hochtemperaturbeanspruchung" 03M3007, Teilbereich Scheibe,
 Partners of the German Cooperative Research Programme:
 IABG, Industrieanlagen-Betriebsgesellschaft mbH, Ottobrunn;
 Institut für Zuverlässigkeit und Schadenskunde im Maschinenbau, Universität Karlsruhe; Max-Planck-Institut für Metallforschung, Institut für Werkstoffwissenschaften, Stuttgart;
 MTU Motoren- und Turbinen-Union, München
- [4] Cooperative Research Programme COST 501; Round II, WP 2
 MTU-Project (Projectleader: W. Betz) : "Bewertung der Reinheit von Knetwerkstoffen für Turbinenscheiben", 03K 12027
- [5] G.W. König and E.E. Affeldt:
 "Experience with a Load Change Technique for Crack Growth Rate Measurements" Proc. of the Conference "Low Cycle Fatigue and Elasto-Plastic Behaviour of Materials", Elsevier Applied Science, 1987, 673-679
- [6] G.W. König, B. Nowak and E.E. Affeldt:
 "The Effect of Minor Cycles on the Growth Rate of Small Cracks in a Turbine Disc Alloy"
 Accepted presentation at the "Third International Conference on Low Cycle Fatigue and Elasto-Plastic Behaviour of Materials", Berlin 1992
- [7] A.J.A. Mom, W.J. Evans and A.A. ten Have:
 Turbistan, a Standard Load Sequence for Aircraft Engine Disks
 presented at the AGARD Specialists Meeting on Damage Tolerance Concepts for Critical Engine Components, San Antonio, Texas, April 1985, AGARD CP 393, pp. 20/1-11
- [8] J.W. Bergmann:
 "The Adequate Use of Standardized Load Sequences for Material Fatigue Evaluation".
 Proc. of SEECO '85 "Product Design Assurance in Engineering", Soc. of Environmental Engineers, London, 1985
- [9] M. Vormwald:
 The Consequences of Short Crack Closure on Fatigue Crack Growth under Variable Amplitude Loading.
 Fatigue Fract. Engng. Mater. Struct., Vol. 14, No. 2/3, pp 205-225 (1991)

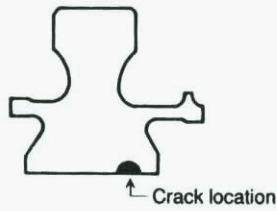

- Cyclic spin pit test
- Material : U700 PM
- Temperature : 400 °C
- Number of cycles : 11255

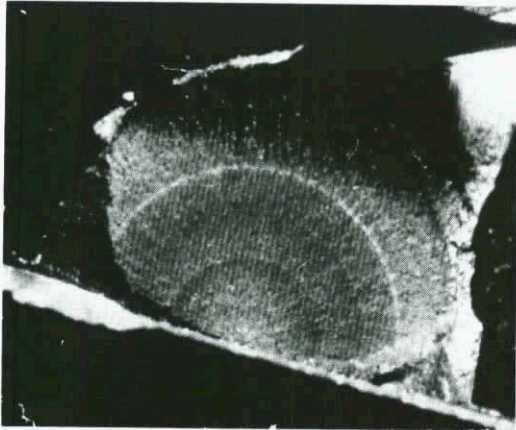

Fatigue crack : General view
 Final depth : 3.8 mm
 Final length : 6.2 mm



Crack initiation at an inclusion

Fig. 1 : Semielliptical surface crack in a disk bore

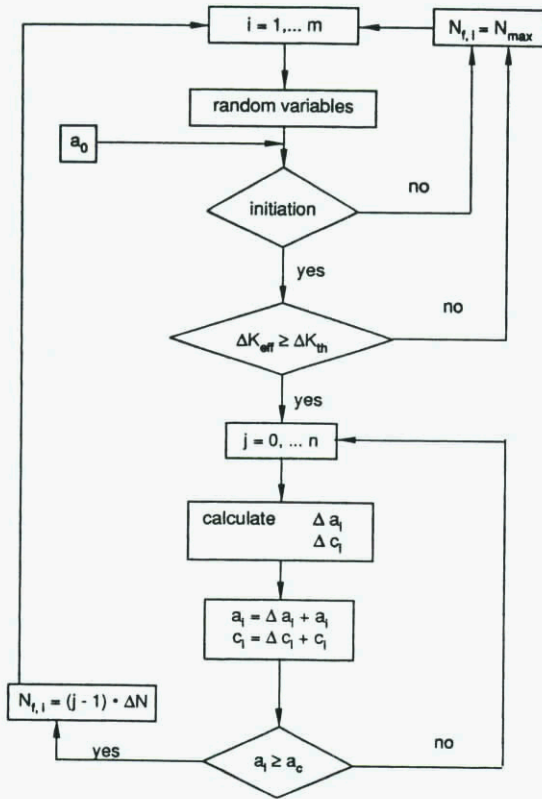

Fig. 2 : Simulation flow chart for the probabilistic living concept

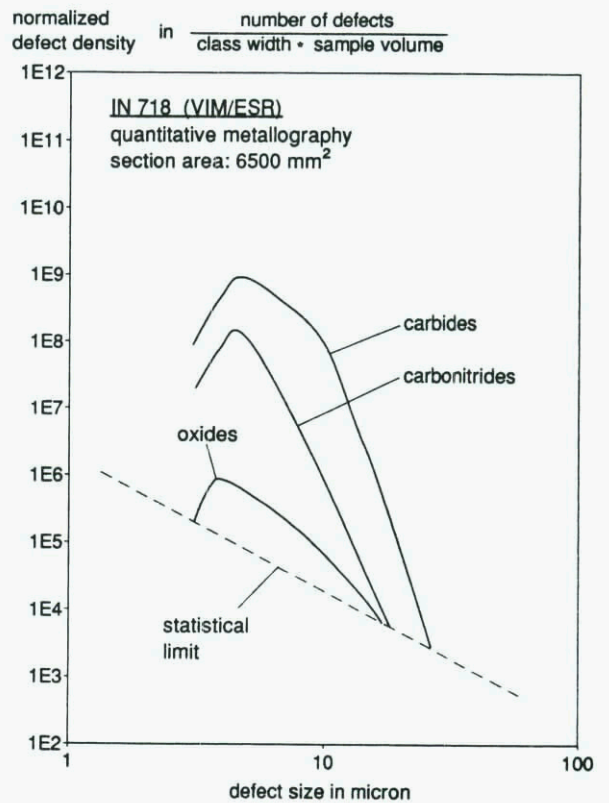

Fig. 3 : Density for various types of defects

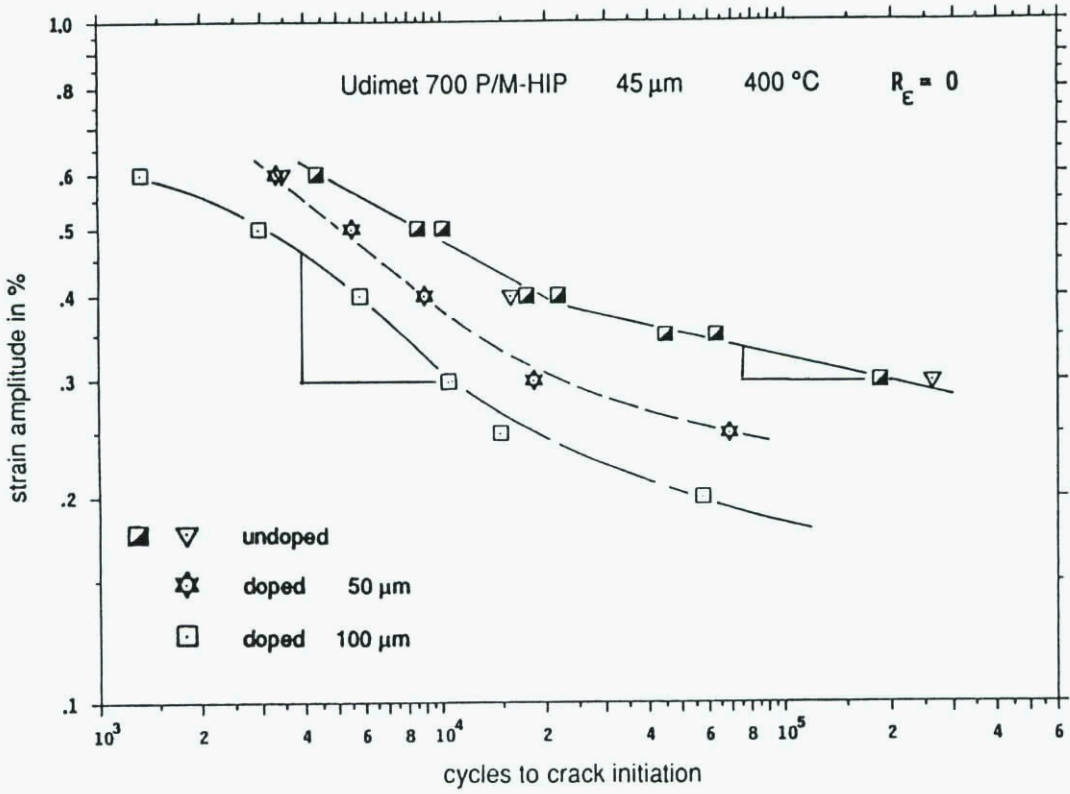

Fig. 4 : LCF - behaviour of smooth specimens under strain control

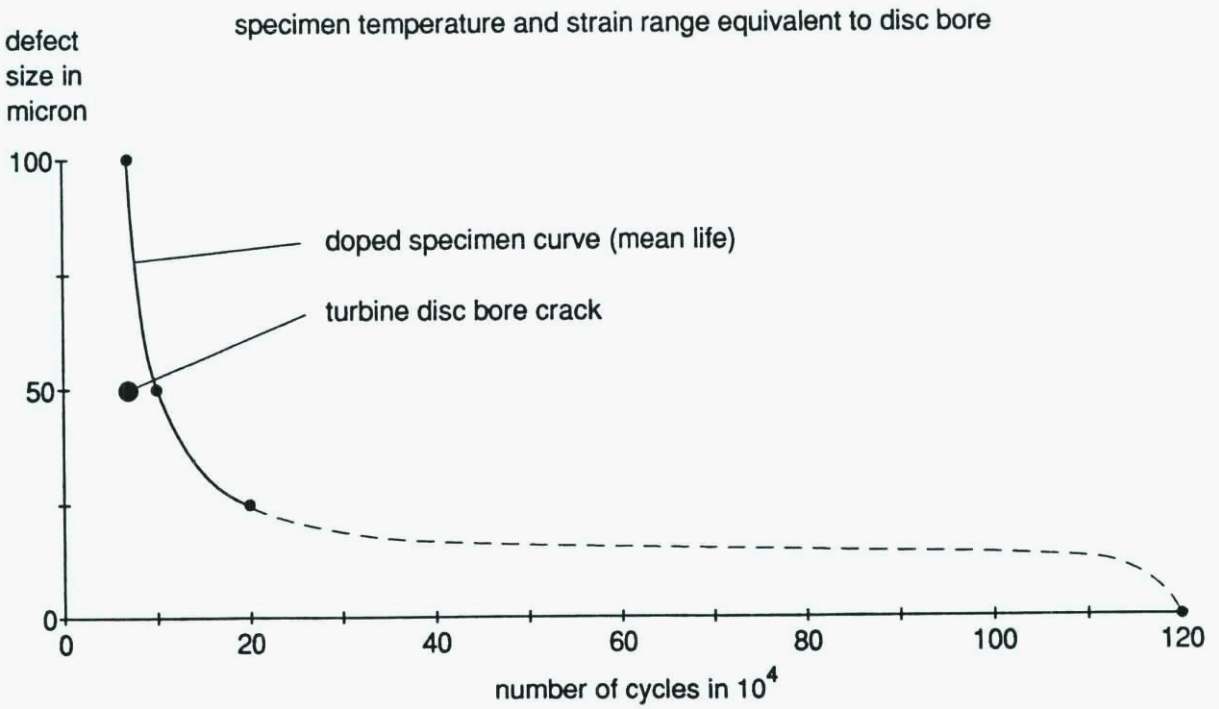

Fig. 5 : Comparison of lives of smooth specimens and disc bore, resp.

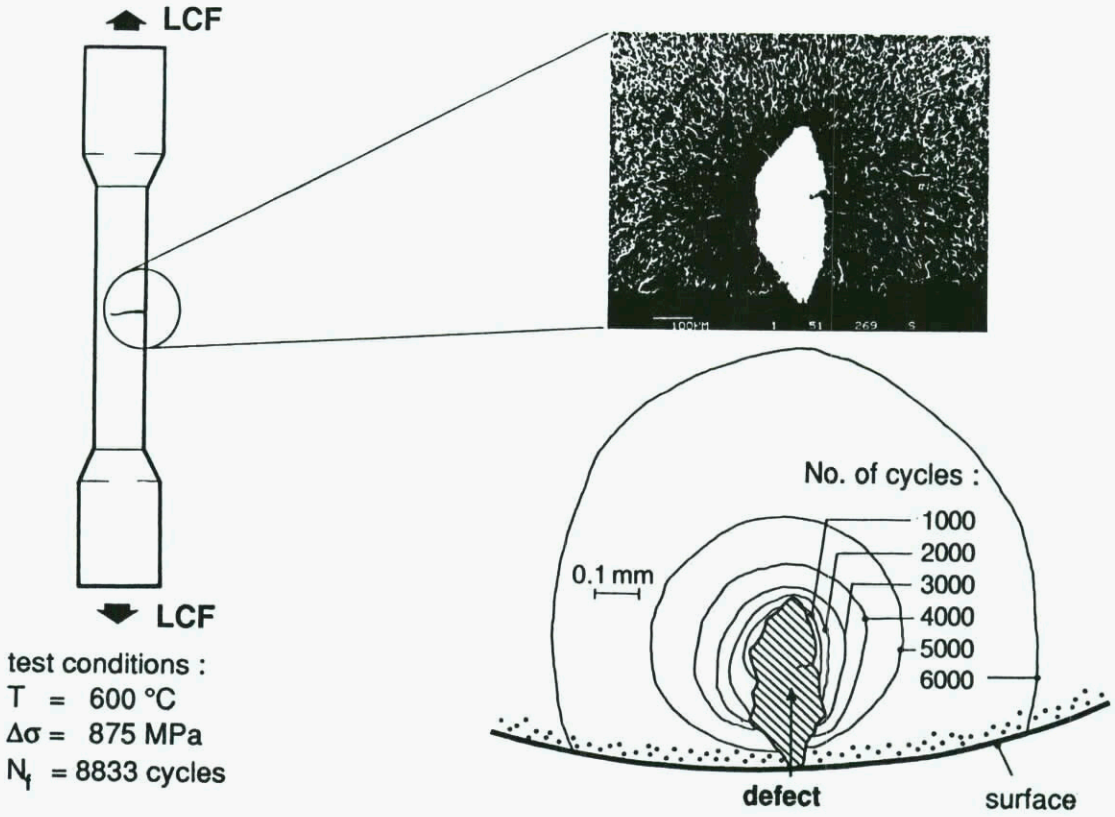

Fig. 6 : Crack initiation and microcrack growth at a nonmetallic inclusion

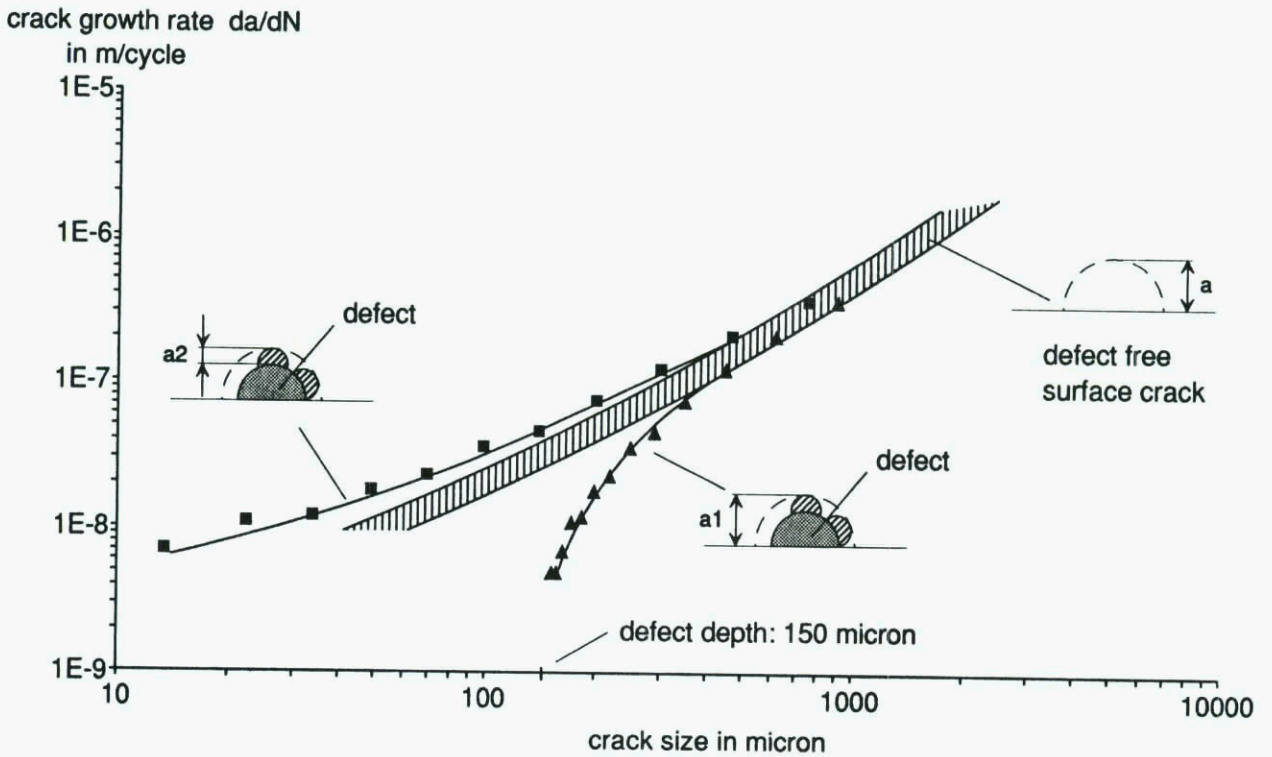

Fig. 7 : Behaviour of cracks starting from defects

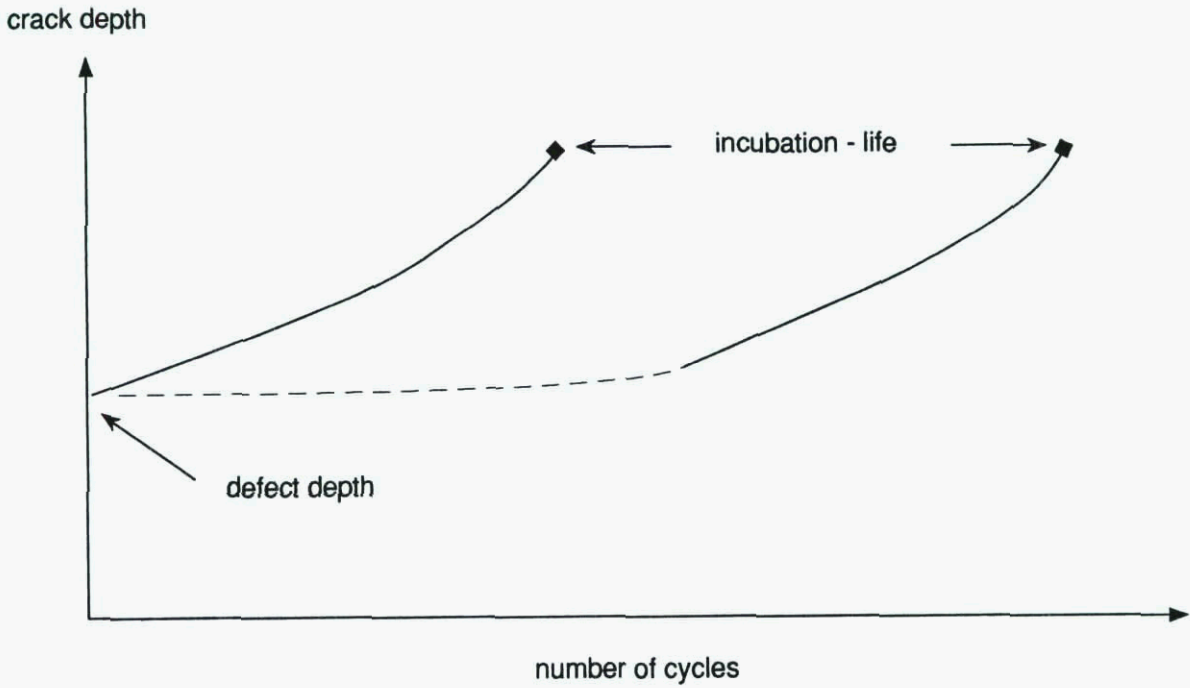

Fig. 8 : Definition of incubation - life

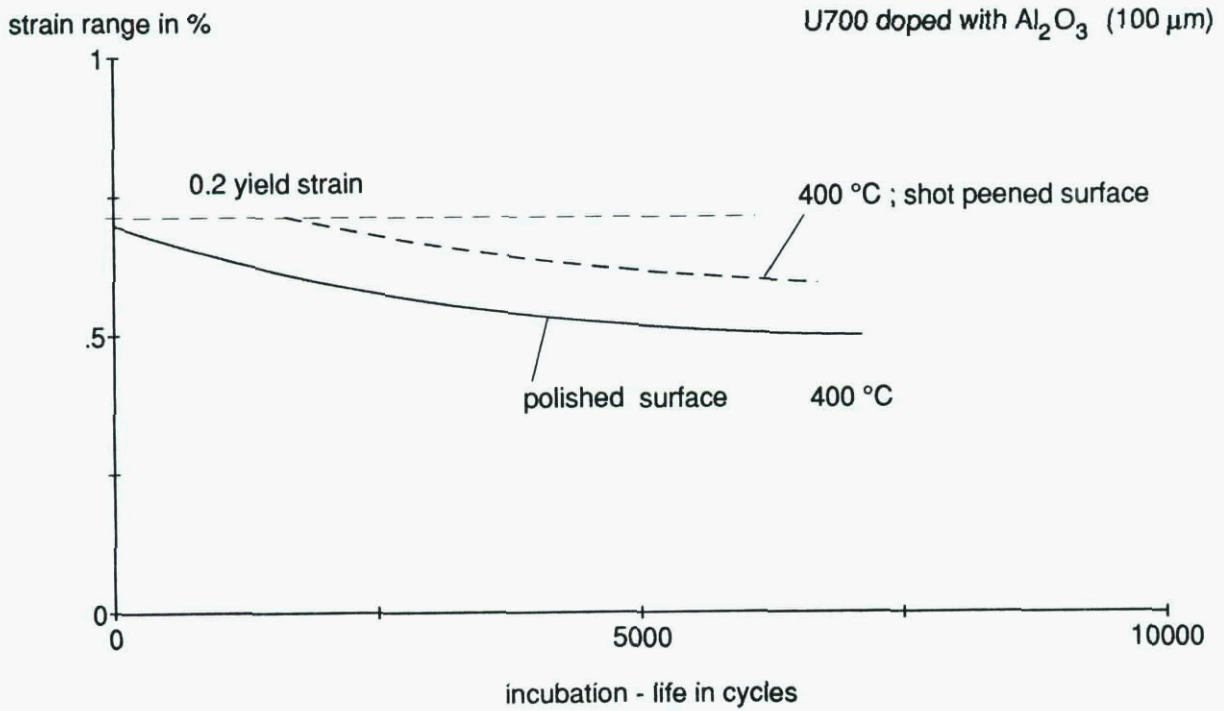

Fig. 9 : Strain dependent incubation - life

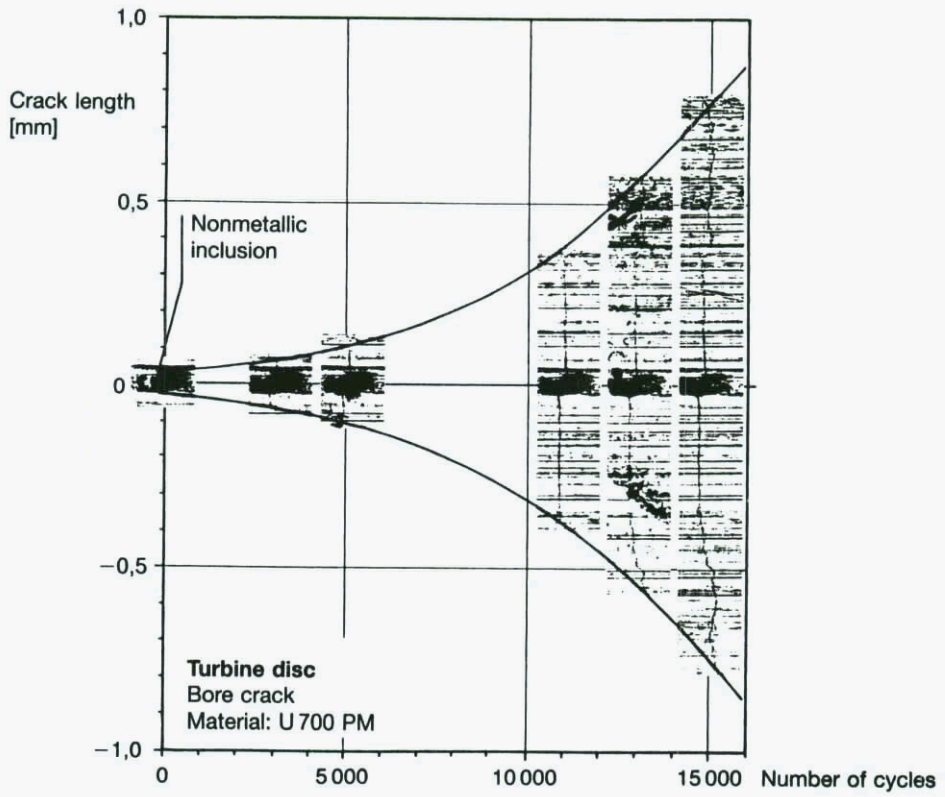

Fig. 10 : Replica micrographs of a bore crack

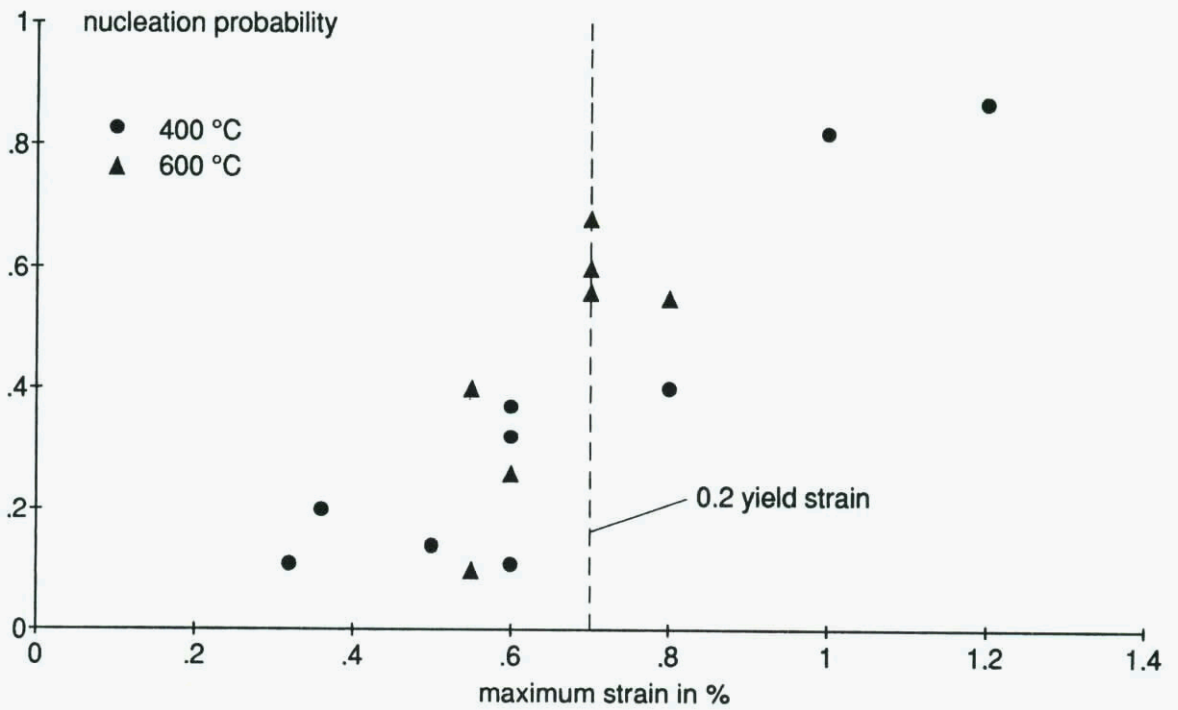

Fig. 11 : Probability of crack nucleation at inclusions

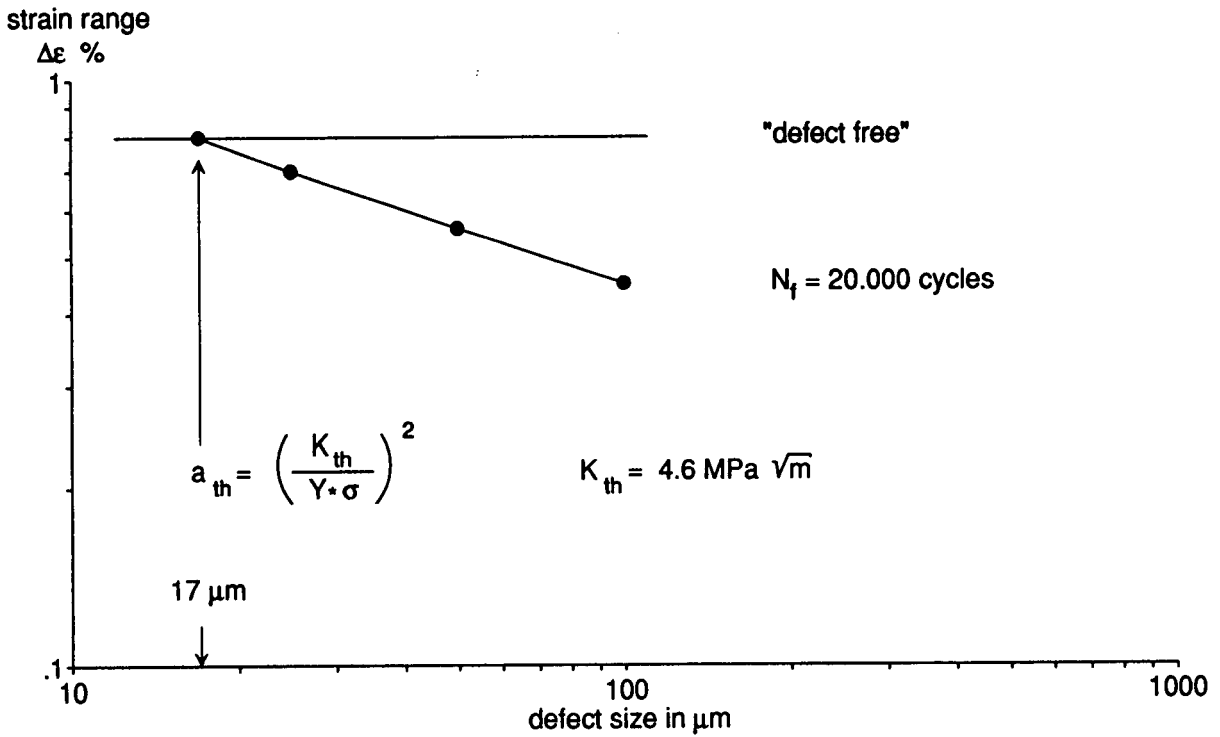

Fig. 12 : Defect size dependent threshold values

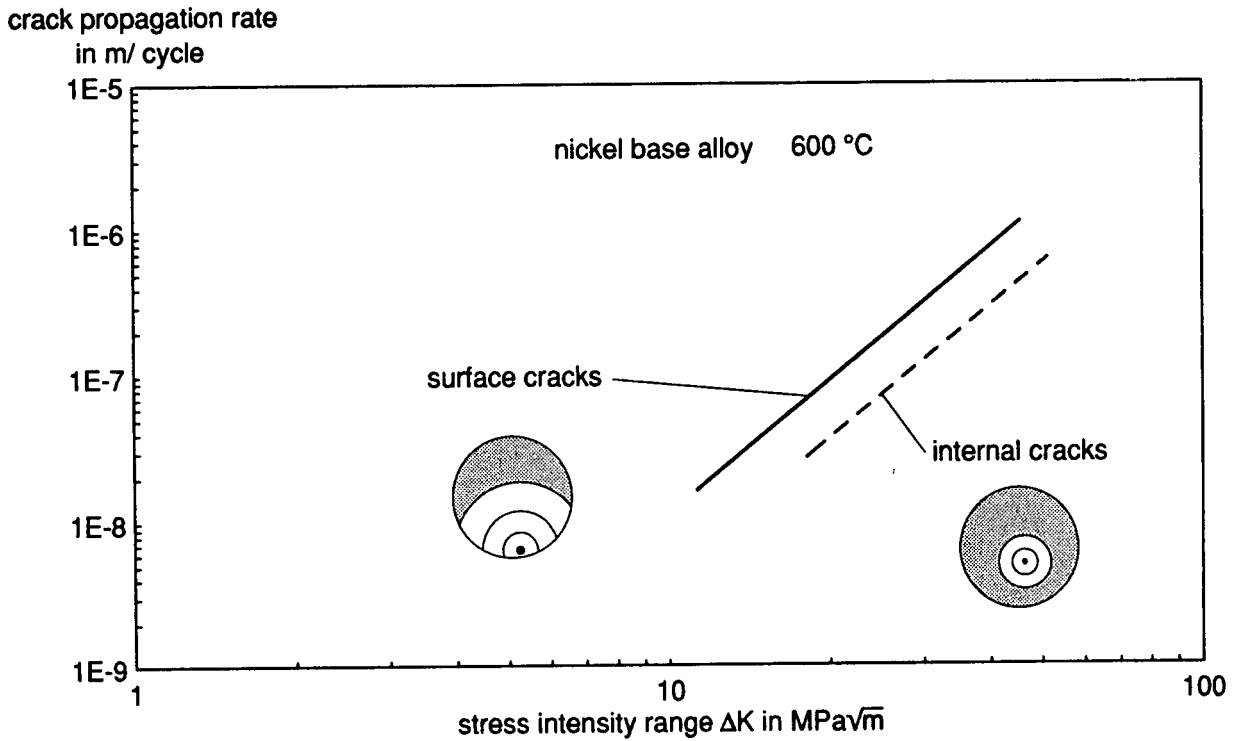

Fig. 13 : Crack propagation of surface and internal cracks

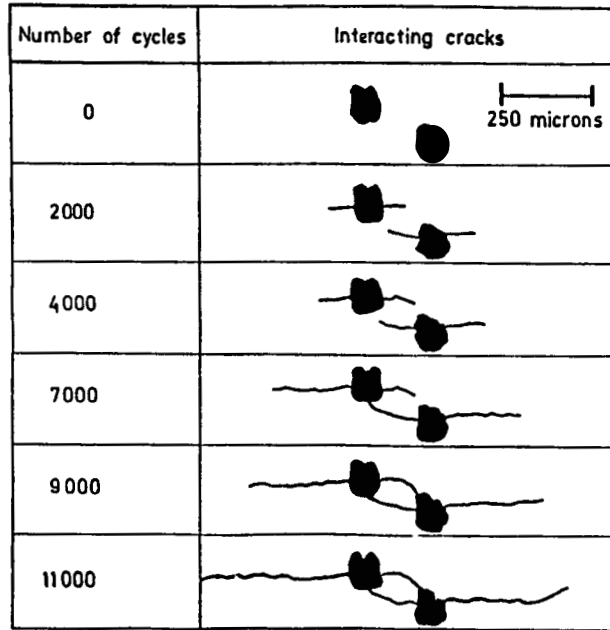

Fig. 14 : Development of interacting cracks

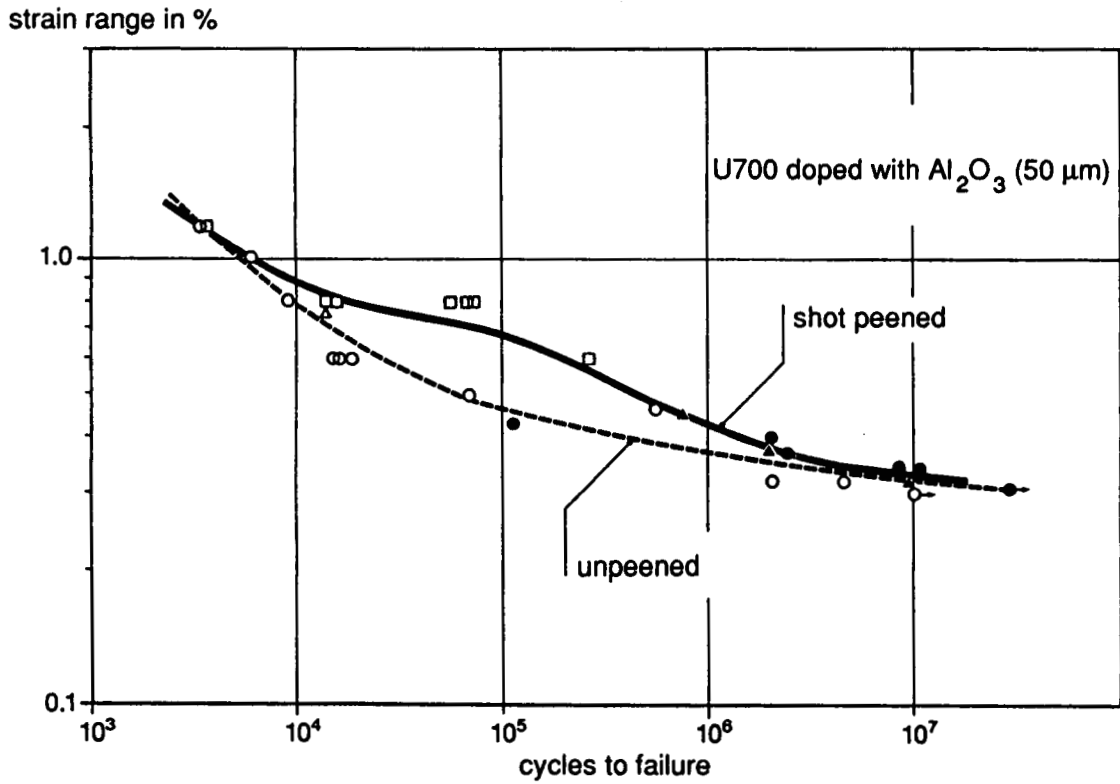

Fig. 15 : Influence of shot peening

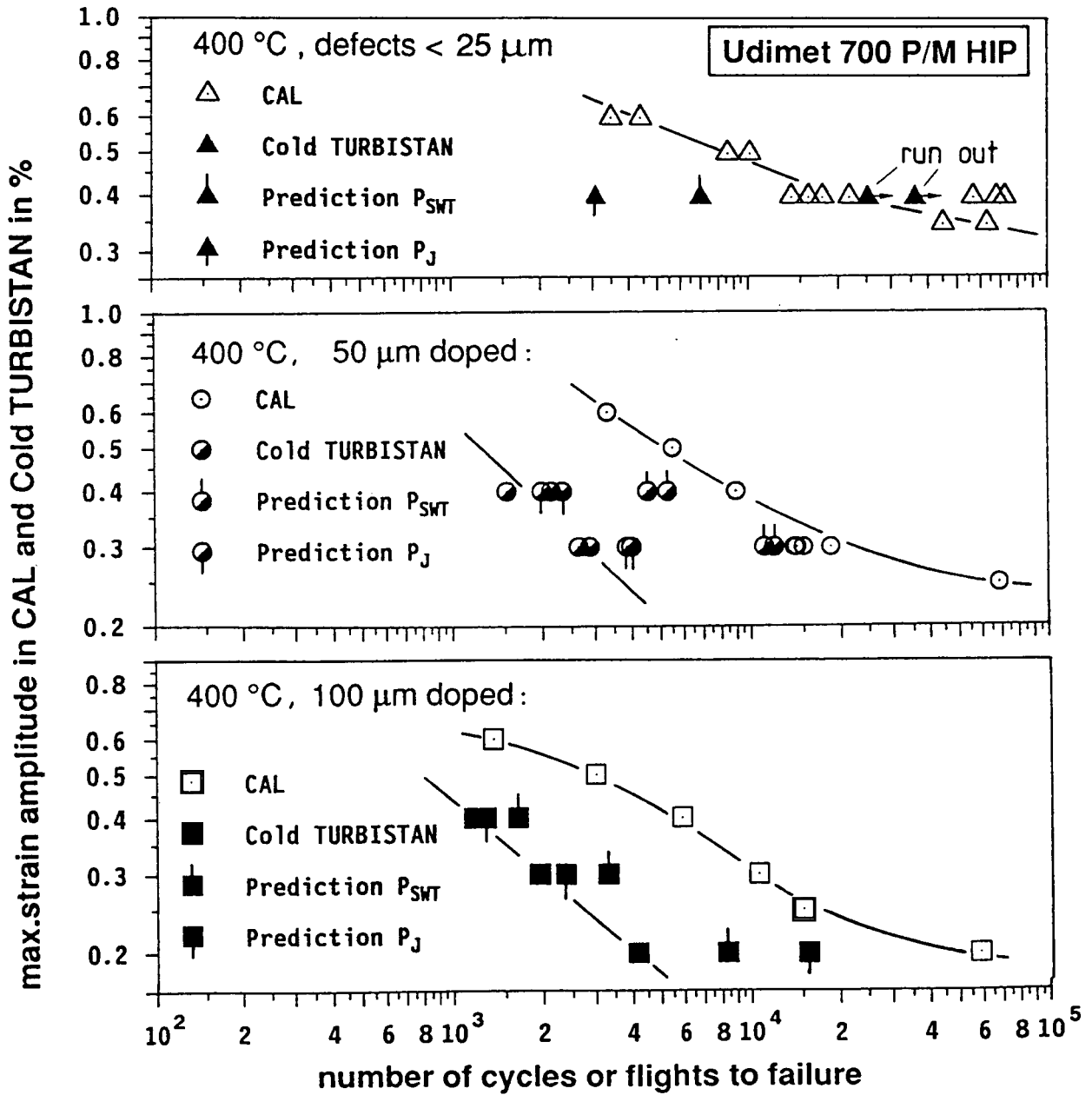

Fig. 16 : Constant (CAL) and variable amplitude tests and respective life predictions

REPORT DOCUMENTATION PAGE											
1. Recipient's Reference	2. Originator's Reference AGARD-R-790	3. Further Reference ISBN 92-835-0711-8	4. Security Classification of Document UNCLASSIFIED/ UNLIMITED								
5. Originator	Advisory Group for Aerospace Research and Development North Atlantic Treaty Organization 7 Rue Ancelle, 92200 Neuilly sur Seine, France										
6. Title	IMPACT OF MATERIALS DEFECTS ON ENGINE STRUCTURES INTEGRITY										
7. Presented at	the 74th Meeting of the Structures and Materials Panel, held in Patras, Greece from 27th—28th May 1992.										
8. Author(s)/Editor(s) Various	9. Date April 1993		11. Pages 114								
10. Author's/Editor's Address Various	12. Distribution Statement There are no restrictions on the distribution of this document. Information about the availability of this and other AGARD unclassified publications is given on the back cover.										
13. Keywords/Descriptors	<table style="width: 100%; border: none;"> <tr> <td style="width: 50%;">Aircraft engines</td> <td style="width: 50%;">Damage</td> </tr> <tr> <td>Jet engines</td> <td>Gas turbine rotors</td> </tr> <tr> <td>Defects</td> <td>Nickel alloys</td> </tr> <tr> <td>Nondestructive tests</td> <td>Titanium alloys</td> </tr> </table>			Aircraft engines	Damage	Jet engines	Gas turbine rotors	Defects	Nickel alloys	Nondestructive tests	Titanium alloys
Aircraft engines	Damage										
Jet engines	Gas turbine rotors										
Defects	Nickel alloys										
Nondestructive tests	Titanium alloys										
14. Abstract	<p>Engine failures due to materials defects are rare, but are still a cause for concern to both manufacturers and lifing authorities. In these circumstances it is recognised that the introduction of higher strength materials, new production routes and improved non-destructive evaluation methods may have significant implications for engine lifing and safety.</p> <p>The impact of inherent defects on present and future component manufacture and on aircraft engine operation is considered. Materials processing and control aspects are reviewed, placing particular emphasis on nickel and titanium engine disc materials.</p> <p>Variations in engineers', scientists' and lawyers' interpretation of the word "defect" was perhaps the most significant point to emerge from the meeting; so much so, that a small group agreed to progress a definition, and when established recommend it as standard AGARD materials technology.</p>										

<p>AGARD Report 790 Advisory Group for Aerospace Research and Development, NATO IMPACT OF MATERIALS DEFECTS ON ENGINE STRUCTURES INTEGRITY Published April 1993 114 pages</p> <p>Engine failures due to materials defects are rare, but are still a cause for concern to both manufacturers and lifting authorities. In these circumstances it is recognised that the introduction of higher strength materials, new production routes and improved non-destructive evaluation methods may have significant implications for engine lifing and safety.</p> <p>The impact of inherent defects on present and future component manufacture and on aircraft engine operation</p> <p>P.T.O.</p>	<p>AGARD-R-790</p> <p>Aircraft engines Jet engines Defects Nondestructive tests Damage Gas turbine rotors Nickel alloys Titanium alloys</p>	<p>AGARD Report 790 Advisory Group for Aerospace Research and Development, NATO IMPACT OF MATERIALS DEFECTS ON ENGINE STRUCTURES INTEGRITY Published April 1993 114 pages</p> <p>Engine failures due to materials defects are rare, but are still a cause for concern to both manufacturers and lifting authorities. In these circumstances it is recognised that the introduction of higher strength materials, new production routes and improved non-destructive evaluation methods may have significant implications for engine lifing and safety.</p> <p>The impact of inherent defects on present and future component manufacture and on aircraft engine operation</p> <p>P.T.O.</p>	<p>AGARD-R-790</p> <p>Aircraft engines Jet engines Defects Nondestructive tests Damage Gas turbine rotors Nickel alloys Titanium alloys</p>
<p>AGARD Report 790 Advisory Group for Aerospace Research and Development, NATO IMPACT OF MATERIALS DEFECTS ON ENGINE STRUCTURES INTEGRITY Published April 1993 114 pages</p> <p>Engine failures due to materials defects are rare, but are still a cause for concern to both manufacturers and lifting authorities. In these circumstances it is recognised that the introduction of higher strength materials, new production routes and improved non-destructive evaluation methods may have significant implications for engine lifing and safety.</p> <p>The impact of inherent defects on present and future component manufacture and on aircraft engine operation</p> <p>P.T.O.</p>	<p>AGARD-R-790</p> <p>Aircraft engines Jet engines Defects Nondestructive tests Damage Gas turbine rotors Nickel alloys Titanium alloys</p>	<p>AGARD Report 790 Advisory Group for Aerospace Research and Development, NATO IMPACT OF MATERIALS DEFECTS ON ENGINE STRUCTURES INTEGRITY Published April 1993 114 pages</p> <p>Engine failures due to materials defects are rare, but are still a cause for concern to both manufacturers and lifting authorities. In these circumstances it is recognised that the introduction of higher strength materials, new production routes and improved non-destructive evaluation methods may have significant implications for engine lifing and safety.</p> <p>The impact of inherent defects on present and future component manufacture and on aircraft engine operation</p> <p>P.T.O.</p>	<p>AGARD-R-790</p> <p>Aircraft engines Jet engines Defects Nondestructive tests Damage Gas turbine rotors Nickel alloys Titanium alloys</p>

<p>is considered. Materials processing and control aspects are reviewed, placing particular emphasis on nickel and titanium engine disc materials.</p> <p>Variations in engineers', scientists' and lawyers' interpretation of the word "defect" was perhaps the most significant point to emerge from the meeting; so much so, that a small group agreed to progress a definition, and when established recommend it as standard AGARD materials technology.</p> <p>Papers presented at the 74th Meeting of the AGARD Structures and Materials Panel, held in Patras, Greece from 27th—28th May 1992.</p> <p>ISBN 92-835-0711-8</p>	<p>is considered. Materials processing and control aspects are reviewed, placing particular emphasis on nickel and titanium engine disc materials.</p> <p>Variations in engineers', scientists' and lawyers' interpretation of the word "defect" was perhaps the most significant point to emerge from the meeting; so much so, that a small group agreed to progress a definition, and when established recommend it as standard AGARD materials technology.</p> <p>Papers presented at the 74th Meeting of the AGARD Structures and Materials Panel, held in Patras, Greece from 27th—28th May 1992.</p> <p>ISBN 92-835-0711-8</p>
<p>is considered. Materials processing and control aspects are reviewed, placing particular emphasis on nickel and titanium engine disc materials.</p> <p>Variations in engineers', scientists' and lawyers' interpretation of the word "defect" was perhaps the most significant point to emerge from the meeting; so much so, that a small group agreed to progress a definition, and when established recommend it as standard AGARD materials technology.</p> <p>Papers presented at the 74th Meeting of the AGARD Structures and Materials Panel, held in Patras, Greece from 27th—28th May 1992.</p> <p>ISBN 92-835-0711-8</p>	<p>is considered. Materials processing and control aspects are reviewed, placing particular emphasis on nickel and titanium engine disc materials.</p> <p>Variations in engineers', scientists' and lawyers' interpretation of the word "defect" was perhaps the most significant point to emerge from the meeting; so much so, that a small group agreed to progress a definition, and when established recommend it as standard AGARD materials technology.</p> <p>Papers presented at the 74th Meeting of the AGARD Structures and Materials Panel, held in Patras, Greece from 27th—28th May 1992.</p> <p>ISBN 92-835-0711-8</p>

AGARD

NATO  OTAN

7 RUE ANCELLE · 92200 NEUILLY-SUR-SEINE
 FRANCE

Télécopie (1)47.38.57.99 · Téléc 610 176

DIFFUSION DES PUBLICATIONS
AGARD NON CLASSIFIEES

Aucun stock de publications n'a existé à AGARD. A partir de 1993, AGARD détiendra un stock limité des publications associées aux cycles de conférences et cours spéciaux ainsi que les AGARDographies et les rapports des groupes de travail, organisés et publiés à partir de 1993 inclus. Les demandes de renseignements doivent être adressées à AGARD par lettre ou par fax à l'adresse indiquée ci-dessus. *Veuillez ne pas téléphoner.* La diffusion initiale de toutes les publications de l'AGARD est effectuée auprès des pays membres de l'OTAN par l'intermédiaire des centres de distribution nationaux indiqués ci-dessous. Des exemplaires supplémentaires peuvent parfois être obtenus auprès de ces centres (à l'exception des Etats-Unis). Si vous souhaitez recevoir toutes les publications de l'AGARD, ou simplement celles qui concernent certains Panels, vous pouvez demander à être inclu sur la liste d'envoi de l'un de ces centres. Les publications de l'AGARD sont en vente auprès des agences indiquées ci-dessous, sous forme de photocopie ou de microfiche.

CENTRES DE DIFFUSION NATIONAUX

ALLEMAGNE

Fachinformationszentrum,
 Karlsruhe
 D-7514 Eggenstein-Leopoldshafen 2

BELGIQUE

Coordonnateur AGARD-VSL
 Etat-Major de la Force Aérienne
 Quartier Reine Elisabeth
 Rue d'Evere, 1140 Bruxelles

CANADA

Directeur du Service des Renseignements Scientifiques
 Ministère de la Défense Nationale
 Ottawa, Ontario K1A 0K2

DANEMARK

Danish Defence Research Board
 Ved Idraetsparken 4
 2100 Copenhagen Ø

ESPAGNE

INTA (AGARD Publications)
 Pintor Rosales 34
 28008 Madrid

ETATS-UNIS

National Aeronautics and Space Administration
 Langley Research Center
 M/S 180
 Hampton, Virginia 23665

FRANCE

O.N.E.R.A. (Direction)
 29, Avenue de la Division Leclerc
 92322 Châtillon Cedex

GRECE

Hellenic Air Force
 Air War College
 Scientific and Technical Library
 Dekelia Air Force Base
 Dekelia, Athens TGA 1010

ISLANDE

Director of Aviation
 c/o Flugrad
 Reykjavik

ITALIE

Aeronautica Militare
 Ufficio del Delegato Nazionale all'AGARD
 Aeroporto Pratica di Mare
 00040 Pomezia (Roma)

LUXEMBOURG

Voir Belgique

NORVEGE

Norwegian Defence Research Establishment
 Attn: Biblioteket
 P.O. Box 25
 N-2007 Kjeller

PAYS-BAS

Netherlands Delegation to AGARD
 National Aerospace Laboratory NLR
 P.O. Box 90502
 1006 BM Amsterdam

PORTUGAL

Portuguese National Coordinator to AGARD
 Gabinete de Estudos e Programas
 CLAFA
 Base de Alfragide
 Alfragide
 2700 Amadora

ROYAUME UNI

Defence Research Information Centre
 Kentigern House
 65 Brown Street
 Glasgow G2 8EX

TURQUIE

Milli Savunma Başkanlığı (MSB)
 ARGE Daire Başkanlığı (ARGE)
 Ankara

Le centre de distribution national des Etats-Unis (NASA/Langley) ne détient PAS de stocks des publications de l'AGARD.
 D'éventuelles demandes de photocopies doivent être formulées directement auprès du NASA Center for Aerospace Information (CASI) à l'adresse suivante:

AGENCES DE VENTE

NASA Center for
 Aerospace Information (CASI)
 P.O. Box 8757
 BWI Airport, Maryland 21240
 United States

ESA/Information Retrieval Service
 European Space Agency
 10, rue Mario Nikis
 75015 Paris
 France

The British Library
 Document Supply Division
 Boston Spa, Wetherby
 West Yorkshire LS23 7BQ
 Royaume Uni

Les demandes de microfiches ou de photocopies de documents AGARD (y compris les demandes faites auprès du CASI) doivent comporter la dénomination AGARD, ainsi que le numéro de série d'AGARD (par exemple AGARD-AG-315). Des informations analogues, telles que le titre et la date de publication sont souhaitables. Veuillez noter qu'il y a lieu de spécifier AGARD-R-nnn et AGARD-AR-nnn lors de la commande des rapports AGARD et des rapports consultatifs AGARD respectivement. Des références bibliographiques complètes ainsi que des résumés des publications AGARD figurent dans les journaux suivants:

Scientific and Technical Aerospace Reports (STAR)
 publié par la NASA Scientific and Technical
 Information Division
 NASA Headquarters (NTT)
 Washington D.C. 20546
 Etats-Unis

Government Reports Announcements and Index (GRA&I)
 publié par le National Technical Information Service
 Springfield
 Virginia 22161
 Etats-Unis

(accessible également en mode interactif dans la base de données bibliographiques en ligne du NTIS, et sur CD-ROM)



AGARD

NATO  OTAN

7 RUE ANCELLE · 92200 NEUILLY-SUR-SEINE

FRANCE

Telefax (1)47.38.57.99 · Telex 610 176

**DISTRIBUTION OF UNCLASSIFIED
 AGARD PUBLICATIONS**

AGARD holds limited quantities of the publications that accompanied Lecture Series and Special Courses held in 1993 or later, and of AGARDographs and Working Group reports published from 1993 onward. For details, write or send a telefax to the address given above. *Please do not telephone.*

AGARD does not hold stocks of publications that accompanied earlier Lecture Series or Courses or of any other publications. Initial distribution of all AGARD publications is made to NATO nations through the National Distribution Centres listed below. Further copies are sometimes available from these centres (except in the United States). If you have a need to receive all AGARD publications, or just those relating to one or more specific AGARD Panels, they may be willing to include you (or your organisation) on their distribution list. AGARD publications may be purchased from the Sales Agencies listed below, in photocopy or microfiche form.

NATIONAL DISTRIBUTION CENTRES

BELGIUM

Coordonnateur AGARD — VSL
 Etat-Major de la Force Aérienne
 Quartier Reine Elisabeth
 Rue d'Evere, 1140 Bruxelles

CANADA

Director Scientific Information Services
 Dept of National Defence
 Ottawa, Ontario K1A 0K2

DENMARK

Danish Defence Research Board
 Ved Idraetsparken 4
 2100 Copenhagen Ø

FRANCE

O.N.E.R.A. (Direction)
 29 Avenue de la Division Leclerc
 92322 Châtillon Cedex

GERMANY

Fachinformationszentrum
 Karlsruhe
 D-7514 Eggenstein-Leopoldshafen 2

GREECE

Hellenic Air Force
 Air War College
 Scientific and Technical Library
 Dekelia Air Force Base
 Dekelia, Athens TGA 1010

ICELAND

Director of Aviation
 c/o Flugrad
 Reykjavik

ITALY

Aeronautica Militare
 Ufficio del Delegato Nazionale all'AGARD
 Aeroporto Pratica di Mare
 00040 Pomezia (Roma)

LUXEMBOURG

See Belgium

NETHERLANDS

Netherlands Delegation to AGARD
 National Aerospace Laboratory, NLR
 P.O. Box 90502
 1006 BM Amsterdam

NORWAY

Norwegian Defence Research Establishment
 Attn: Biblioteket
 P.O. Box 25
 N-2007 Kjeller

PORTUGAL

Portuguese National Coordinator to AGARD
 Gabinete de Estudos e Programas
 CLAFA
 Base de Alfragide
 Alfragide
 2700 Amadora

SPAIN

INTA (AGARD Publications)
 Pintor Rosales 34
 28008 Madrid

TURKEY

Milli Savunma Başkanlığı (MSB)
 ARGE Daire Başkanlığı (ARGE)
 Ankara

UNITED KINGDOM

Defence Research Information Centre
 Kentigern House
 65 Brown Street
 Glasgow G2 8EX

UNITED STATES

National Aeronautics and Space Administration (NASA)
 Langley Research Center
 M/S 180
 Hampton, Virginia 23665

The United States National Distribution Centre (NASA/Langley) does NOT hold stocks of AGARD publications.
 Applications for copies should be made direct to the NASA Center for Aerospace Information (CASI) at the address below.

SALES AGENCIES

NASA Center for
 Aerospace Information (CASI)
 P.O. Box 8757
 BWI Airport, Maryland 21240
 United States

ESA/Information Retrieval Service
 European Space Agency
 10, rue Mario Nikis
 75015 Paris
 France

The British Library
 Document Supply Centre
 Boston Spa, Wetherby
 West Yorkshire LS23 7BQ
 United Kingdom

Requests for microfiches or photocopies of AGARD documents (including requests to CASI) should include the word 'AGARD' and the AGARD serial number (for example AGARD-AG-315). Collateral information such as title and publication date is desirable. Note that AGARD Reports and Advisory Reports should be specified as AGARD-R-*nnn* and AGARD-AR-*nnn*, respectively. Full bibliographical references and abstracts of AGARD publications are given in the following journals:

Scientific and Technical Aerospace Reports (STAR)
 published by NASA Scientific and Technical
 Information Division

Government Reports Announcements and Index (GRA&I)
 published by the National Technical Information Service

NASA
 Washi
 United



317654++P+UL

UNLIMITED