

Please read

Knowledge Services has become aware of potential faults in some of our older scanned documents. We are putting this disclaimer on the front of every document in the batch concerned. We are making them available, as they do remain substantially usable.

The following document may contain errors. It was scanned when the software was at a previous version and quality checking was unable to pick up some of the problems that are now apparent.

Most of the errors will be cosmetic - variation in fonts and fuzziness. From time to time the OCR capability has proved faulty and word substitution has occurred.

We are sorry that this version of the report may be poorer than we would wish. If there are significant errors or you have doubts about what you are reading due to poor quality, please contact Knowledge Services as below and we will try to remedy the problem. Ensure that your request identifies that the current pdf version is unsatisfactory.

knowledge-services@dstl.gov.uk

332690

UNLIMITED

AGARD-LS-202

AGARD-LS-202

AGARD

ADVISORY GROUP FOR AEROSPACE RESEARCH & DEVELOPMENT
7 RUE ANCELLE, 92200 NEUILLY-SUR-SEINE, FRANCE

AGARD LECTURE SERIES NO 202

Current Concepts on G-Protection Research and Development

(Concepts actuels en R&D pour la protection anti-G)

The material in this publication was prepared at the request of the Aerospace Medical Panel and under the sponsorship of the Consultant and Exchange Programme of AGARD and will be presented on 15-16 May 1995 in Ohio, USA, 12-13 June 1995 in Königsbrück, Germany and 15-16 June 1995 in Farnborough, UK.

Processed / not processed by DIMS

.....signed.....date

NOT FOR DESTRUCTION

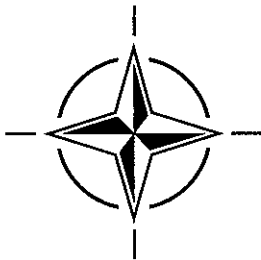

NORTH ATLANTIC TREATY ORGANIZATION

Published May 1995

Distribution and Availability on Back Cover

AGARD-LS-202



AGARD-LS-202

AGARD

ADVISORY GROUP FOR AEROSPACE RESEARCH & DEVELOPMENT
7 RUE ANCELLE, 92200 NEUILLY-SUR-SEINE, FRANCE

AGARD LECTURE SERIES NO 202

Current Concepts on G-Protection Research and Development

(Concepts actuels en R&D pour la protection anti-G)

The material in this publication was prepared at the request of the Aerospace Medical Panel and under the sponsorship of the Consultant and Exchange Programme of AGARD and will be presented on 15-16 May 1995 in Ohio, USA, 12-13 June 1995 in Königsbrück, Germany and 15-16 June 1995 in Farnborough, UK.

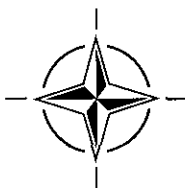

North Atlantic Treaty Organization
Organisation du Traité de l'Atlantique Nord

The Mission of AGARD

According to its Charter, the mission of AGARD is to bring together the leading personalities of the NATO nations in the fields of science and technology relating to aerospace for the following purposes:

- Recommending effective ways for the member nations to use their research and development capabilities for the common benefit of the NATO community;
- Providing scientific and technical advice and assistance to the Military Committee in the field of aerospace research and development (with particular regard to its military application);
- Continuously stimulating advances in the aerospace sciences relevant to strengthening the common defence posture;
- Improving the co-operation among member nations in aerospace research and development;
- Exchange of scientific and technical information;
- Providing assistance to member nations for the purpose of increasing their scientific and technical potential;
- Rendering scientific and technical assistance, as requested, to other NATO bodies and to member nations in connection with research and development problems in the aerospace field.

The highest authority within AGARD is the National Delegates Board consisting of officially appointed senior representatives from each member nation. The mission of AGARD is carried out through the Panels which are composed of experts appointed by the National Delegates, the Consultant and Exchange Programme and the Aerospace Applications Studies Programme. The results of AGARD work are reported to the member nations and the NATO Authorities through the AGARD series of publications of which this is one.

Participation in AGARD activities is by invitation only and is normally limited to citizens of the NATO nations.

The content of this publication has been reproduced
directly from material supplied by AGARD or the authors.

Published May 1995

Copyright © AGARD 1995
All Rights Reserved

ISBN 92-836-0016-9



Printed by Canada Communication Group
45 Sacré-Cœur Blvd., Hull (Québec), Canada K1A 0S7

Preface

Current Concepts on G-Protection Research and Development

A new class of fighter aircraft is emerging that will be operational or in advanced Test and Evaluation by 1995. These aircraft (e.g. MiG 31, YF-22, Eurofighter, Rafale) are capable of developing G far in excess of 9G (i.e. 12G will be a realistic capability). The operational envelope of these agile aircraft will depend upon the G protection provided to the aircrew. In response to this challenge, established and new laboratories using human-use centrifuges are developing new aircrew protection methods using different approaches yet frequently complementing the research of the others. These laboratories include: Armstrong Laboratory (US), SAM (UK), DCIEM (CA), LAMAS (FR), SAM (RU), KONIGSBRUCK Laboratory (GE) and FOA Laboratory (SW). In 1995, much of this research will have produced prototype flight-worthy equipment/methods with advanced understanding of their physiological bases. This lecture series will review: (a) pathophysiology of high sustained G (9G and above); (b) recent equipment development and reports on equipment T&E. Therefore this lecture series will be timely and extremely important regarding new advanced weapons systems. Numerous AGARD technology linkages will be manifest.

In consideration of recent funding constraints of AGARD, these lecture series will utilize maximally local scientific contributions with a guest lecture concept. Consequently the publication will be extensive containing the material of these guest lecturers and those of the permanently appointed lectures, i.e. all significant research in this area from major scientists in all major laboratories will contribute. In addition, with Dr. General Stupakov's participation, it will be a FSU collaborative research effort. Interestingly and relevant here is that the SAM (Moscow) G protection research programme is significant and with breakthrough potential.

Préface

Concepts actuels en recherche et développement pour la protection anti-G

Une nouvelle génération d'avions de combat est en cours de développement (MIG-31, YF-22, Eurofighter, Rafale, etc.). Ces avions, qui seront d'ici la fin 1995 soit au stade des essais, soit à celui de leur utilisation opérationnelle, seront capables de produire des accélérations supérieures à 9 +Gz (une valeur de 12 +Gz est envisagée pour certains d'entre eux). La capacité d'utilisation opérationnelle de ces aéronefs particulièrement manœuvrants dépendra de la qualité de la protection anti-G fournie à leurs équipages. Pour relever ce défi, plusieurs laboratoires, réputés ou moins connus, utilisant des centrifugeuses humaines effectuent des recherches complémentaires pour mettre au point de nouvelles protections anti-G. Ces laboratoires, dont la plupart appartiennent à des pays de l'OTAN, dépendent des Institutions suivantes: le Laboratoire Armstrong (AL) aux États-Unis (US), l'École de Médecine Aéronautique (SAM) au Royaume Uni (UK), l'Institut Civil et de Défense de Médecine Environnementale (DCIEM) au Canada (CA), le Laboratoire de Médecine Aérospatiale du Centre d'Essais en Vol (LAMAS) en France (F), l'Institut de Médecine Aérospatiale (IAM) de Russie (RU), le Laboratoire de Königsbrück en Allemagne (G) et le Département des Études Facteur Humain de l'Établissement de Recherche de la Défense Suédoise (FOA), (S). Plusieurs de ces travaux ont abouti en 1995 à la réalisation d'équipements de vols prototypes ou à la mise au point de nouvelles méthodes prenant en compte les avancées dans le domaine des bases physiologiques.

Ce cycle de conférences présente: (a) la physiopathologie des accélérations soutenues et très élevées (9 +Gz et plus), (b) les récents développements concernant les équipements et les moyens d'essais pour les évaluer. En conséquence, ce cycle de conférences est particulièrement important vis-à-vis des améliorations des nouveaux systèmes d'armes et arrive à un moment opportun. De nombreuses implications technologiques en découlent.

Eu égard aux contraintes budgétaires récentes imposées à l'AGARD, ce cycle de conférences fait appel, non seulement à des conférenciers permanents mais aussi, dans toute la mesure du possible, à des contributions locales, c'est-à-dire à des conférenciers invités; par conséquent, les publications sont particulièrement nombreuses. Ceci permet aux principaux scientifiques de tous les grands laboratoires de faire l'exposé de l'ensemble des travaux de recherche réalisés dans le domaine de la physiologie appliquée à la protection anti-G. De plus, la contribution du Médecin Général Stupakov (Russie) marque les efforts de collaboration Est-Ouest dans ce domaine de recherche. Dans ce contexte, il est important de souligner que les recherches menées par la Russie sont prometteuses du fait des percées technologiques potentielles.

List of Authors/Speakers

Lecture Series Director: Médecin en Chef Jean Michel CLERE
Laboratoire de Médecine Aérospatiale
Centre d'Essais en Vol
F91228 Brétigny-sur-Orge Cedex
FRANCE

Authors/Speakers

Dr. John BURNS
AL/CFTF
2504 Gillingham Drive
Suite No. 1
BROOKS AFB, TX 78235-5104
USA

General Guryi STUPAKOV
Chief of Institute of Aerospace
Medicine
Petrovsko-Rasumosvskaja Avenue 12
125083 Moscow A-83
RUSSIA

Dr. Fred BUICK
Human Protection Systems Division
DCIEM
1133 Shephard Avenue West
P.O. Box 2000
North York, Ontario
CANADA, M3M 3B9

Wing Commander Andy PRIOR
Head, Operational Aviation Medicine
RAF School of Aviation Medicine
Farnborough
Hants, GU14 6SZ
UK

Professor Ulf BALLDIN
Research Director
AL/CFTF
2504 Gillingham Dr.
Suite 1,
Brooks AFB,
Texas 78235-5104
USA

OTA Dr Heiko WELSCH
Leiter ABT II-
Flugmedizinisches Institut der Luftwaffe
Steinbornerstr. 43
D-01936 Königsbrück
GERMANY

Contents

	Page
Preface/Préface	iii
List of Authors/Speakers	iv
G-Protection Basis/Acceleration Physiology by Dr. J.W. BURNS	1
Negative to Positive Gz Acceleration Transition by Wing Commander A. PRIOR	2
Selection and Special Physiological Training of Flying Personnel to High +Gz-Maneuverable Flights-Main Concept by General G.P. STUPAKOV and Mr. M.N. KHOMENKO	3
Anti G-Suits by Médecin en Chef J.M. CLERE, G. OSSARD and M. KERGUELEN	4
Positive Pressure Breathing for G-Protection (PBG) by Wing Commander A. PRIOR	5
Increase of High Sustained +Gz Tolerance at the Expense of Pilot's Working Posture Change by General G.P. STUPAKOV and Mr. M.N. KHOMENKO	6
New Advances in Physiological Measurements during High-G: Technology by Professor U.I. BALLDIN	7
Methods for Measuring Physiological Responses and Protection in Man Exposed to High +Gz by Dr. F. BUICK, Mr. E.H. WOOD, Mr. M. PECARIC and Mr. J. MALOAN	8
Selection and Training of MiG-29 and Future Fighter Pilots by Col. M.C. Dr. H. WELSCH	9
G-Protection Capabilities and Current G-Protection Issues by Dr. J.W. BURNS	10
Les études menées par l'AGARD et les avancées nouvelles pour les programmes futurs by Médecin en Chef J.M. CLERE, P. SANDOR and A. LEGER	11



G-PROTECTION BASIS/ACCELERATION PHYSIOLOGY

JW BURNS

Crew Technology Division
 Armstrong Laboratory
 Brooks AFB TX 78235-5104
 USA

Our major objective is to protect the aircrew against the detrimental effects of $+G_z$ by developing and assessing equipment and techniques to enhance high sustained acceleration ($+G_z$) tolerance, and minimize the hazards of G-LOC. The payoff is reduced pilot fatigue and improved combat effectiveness. To accomplish these objectives it is imperative that we learn as much as possible regarding acceleration physiology and the influence that protective equipment and techniques have on acceleration physiology.

Figure 1 illustrates maneuvering acceleration and the resultant inertial force that I will be discussing throughout this lecture. $+G_z$ is the correct terminology, however, sometimes G or G_z will be used as abbreviations. There are several excellent textbooks which discuss the effects of acceleration in much greater detail (1,9). The three functional areas of the body most

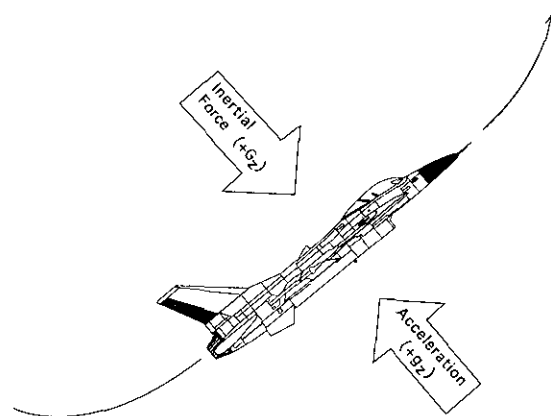

Figure 1. Maneuvering acceleration and the equal, but opposite, inertial force that aircrew are exposed to during flight.

sensitive to acceleration are: the cardiovascular system, the pulmonary system and the central nervous system (CNS). The cardiovascular and pulmonary systems will be addressed in this lecture and the CNS will be covered in a following lecture.

Two of the major cardiovascular problems associated with high sustained $+G_z$ are maintenance of venous return to the heart and the maintenance of blood pressure and blood flow to the brain. Eye-level blood pressure (ELBP) is known to decrease by 22-25 mmHg/G as a result of the inertial load on the eye-to-heart hydrostatic column of blood. Thus, the brain is at a disadvantage when the body is in the upright position ($+1G_z$), where, if mean blood pressure at heart level is 100 mmHg then brain level blood pressure will be around 78 mmHg, assuming a 30 cm eye-to-heart distance (Figure 2). As $+G_z$ progresses from $+1G_z$ to $+5G_z$ then ELBP will decrease from 78 mmHg to -10 mmHg, resulting in a G-induced loss of consciousness (G-LOC), assuming no interventions. During $+G_z$, venous return generally decreases significantly, whereas with adequate protective equipment and the anti-G straining maneuver (AGSM) adequate brain level blood pressure and flow can be maintained. Recent swine data demonstrate that with adequate venous return support (improved G-suit) brain level blood pressure and flow can be maintained with significantly reduced straining effort (4,5).

The normal cardiovascular compensatory responses to $+G_z$ are an immediate increase in heart rate (HR) and a slower increase in peripheral resistance and relocation of blood volume. Figure 3 illustrates the car-

Hydrostatic Blood Pressure Effects

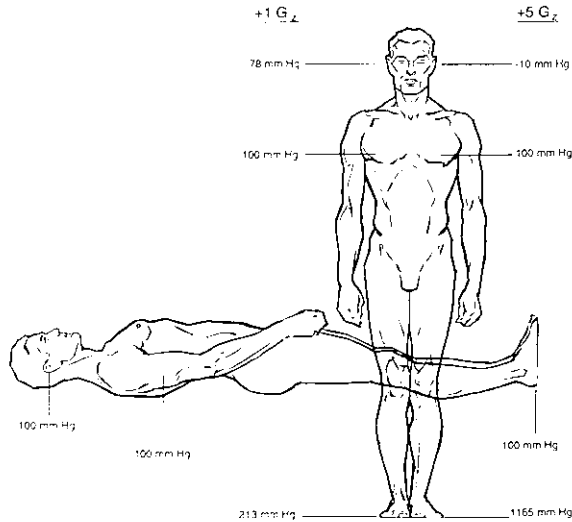

Figure 2. Schematic of the hydrostatic blood pressure in the supine position, and erect position at +1G_z and +5G_z.

divascular response to a +3G_z exposure in an anesthetized animal. Note the dramatic decrease in left ventricular and eye-level blood pressures with the onset of +G_z and the reflex compensation that occurs as the +G_z profile progresses. Although mean aortic pressure changed very little, the large reduction in pulse pressure was related to reduced left ventricular peak pressure resulting from a reduced venous return to the heart during +G_z. The rise in left ventricular pressure as the +G_z exposure progressed was an autonomic response (note increase in dp/dt) and was not associated with an increase in pulse pressure, probably because venous return had not improved, as evidenced by a decreased left ventricular end-diastolic filling pressure. Notice that the decrease in ELBP is almost linear with the onset of +G_z.

Venous return into the thorax can only occur when venous pressure at the venous inlets to the thorax is greater than intrathoracic pressure. There is generally a positive abdominal-thoracic venous pressure

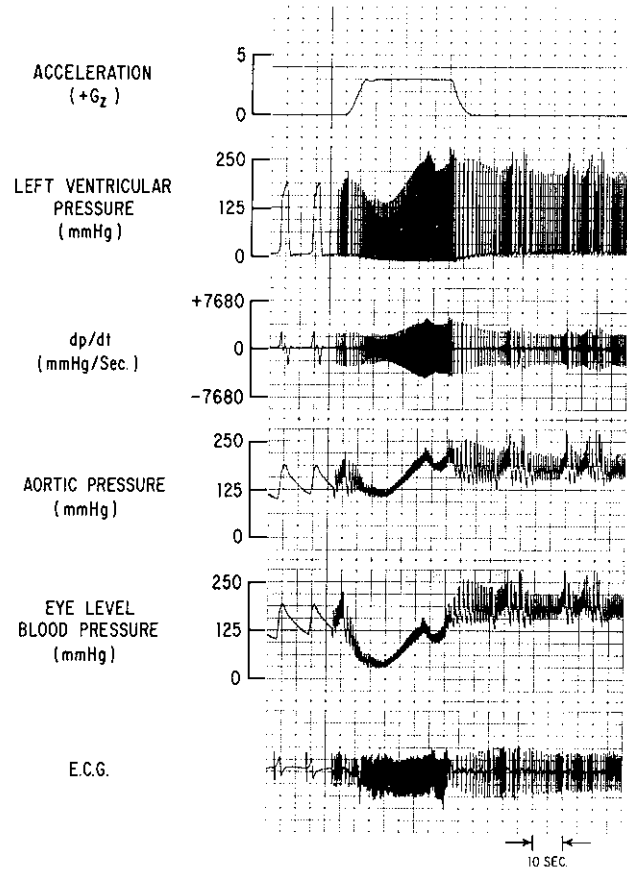
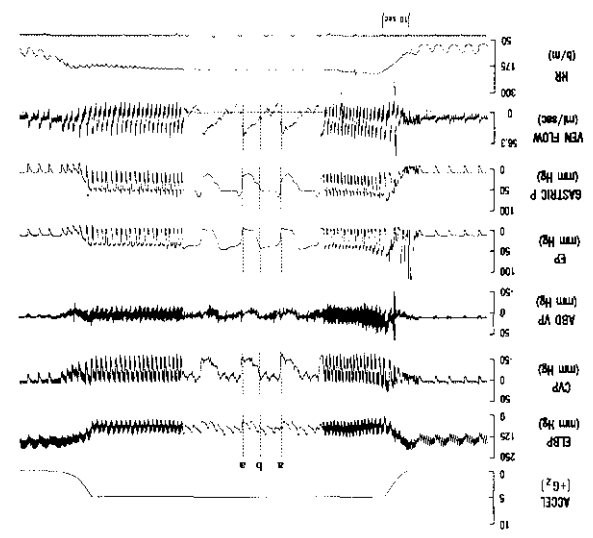

Figure 3. The influence of +3G_z for 30 sec on left ventricular, aortic and eye-level blood pressure of an anesthetized animal.

gradient, which is amplified by G-suit inflation (6). However, the gradient decreases dramatically during the strain, explaining the sharp reduction in venous return through the diaphragm at that time. Upon initiation of the AGSM venous flow abruptly becomes negative, gradually increases throughout the strain and then increases sharply during the no strain period (expiration/inspiration), and becomes greatest just prior to the next strain (Figure 4). If the AGSM is maintained too long venous return will be further decreased, as in the Valsalva maneuver, cardiac output will be dramatically reduced and ELBP will decrease, even though BP is normally elevated by the AGSM. On the other hand, if the time between strains is extended beyond several seconds the extended loss

of ELBP and blood flow to the brain will result in loss of vision and/or consciousness (G-LOC) if not corrected. Thus it is extremely important that the AGSM be cycled every 3-5 sec to allow venous return during expiration/inspiration between strains, followed by the generation of pressure during the strain. Pressure breathing for +Gz protection (PBG) adds an additional impediment to venous return by passively elevating intrathoracic pressure by as much as 60 mmHg at +9Gz (see below). Figure 5 illustrates the importance of a strong and rhythmic AGSM during a sustained +8Gz/30 sec exposure in man (2). ELBP was obtained from a cannula in the non-dominant radial artery of a centrifuge subject and connected to a transducer at eye level. Esophageal pressure (EP) was obtained from a latex rubber balloon catheter passed through the nasopharynx into the esophagus, placed at mid-chest level and connected to an external transducer. Note that when EP decreased during the expiration/inspiration period, between strains, ELBP fell precipitously below zero and then rose sharply when EP rose during

Figure 4. Influence of the anti-G straining maneuver (AGSM), measured by esophageal pressure (EP), on other measured parameters, especially venous flow.



the strain. At about midway through the +Gz exposure the subject was instructed to let up on the strain to lose approximately 25% of their peripheral vision to insure that they did not strain more than necessary. Note the reduction in EP at mid-exposure. Rushmer has demonstrated that rectal pressure, and thus abdominal pressure,

Figure 5. Human AGSM response to +8Gz with anti-G suit support. Note the dramatic fall in eye-level blood pressure between strains.

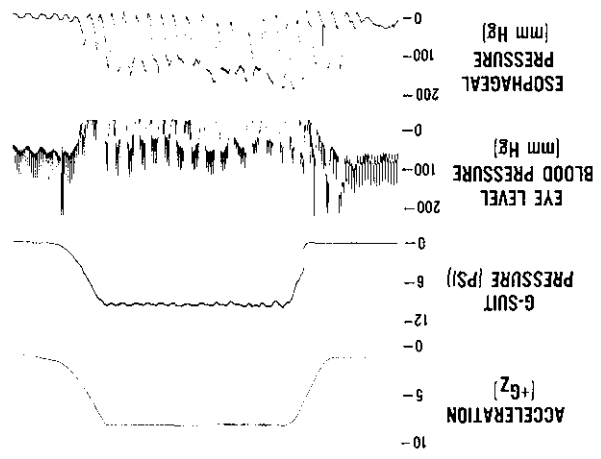
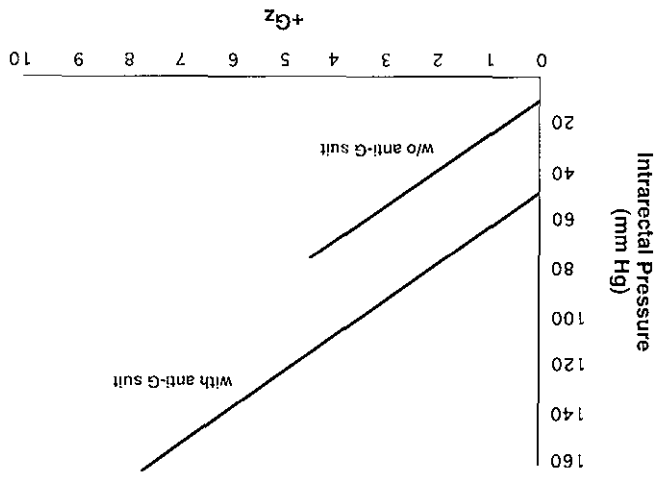

Figure 6. Intrarectal pressure with and without an anti-G suit at various +Gz levels. From: Rushmer, R.F. J. Aviat. Med. 18:96-101, 1947.



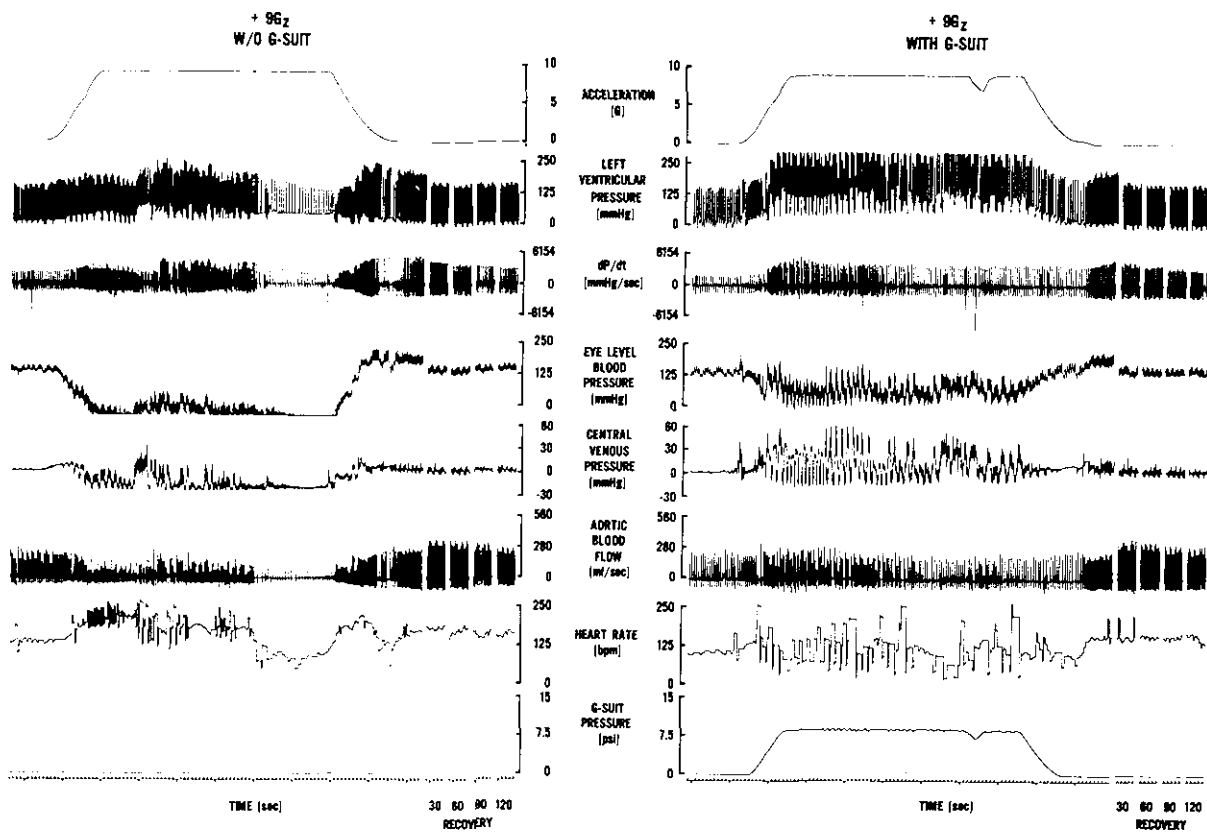

Figure 7. Sixty second exposure of unanesthetized swine to +9Gz without (left) and with (right) anti-G suit inflation.

increased linearly with +G_z, with and without an anti-G suit, but at a higher level with the G suit (Figure 6). He found that at +5G_z a column of blood could be supported to several centimeters above the dome of the diaphragm with G suit support (11). This information indicates that venous return from below the diaphragm is supported by hydrostatic tissue pressure. However, without anti-G suit support the compliance of the areas below the diaphragm allows venous pooling and insufficient venous return to the heart during high levels of +G_z. The anti-G suit provides anti-G support by reduced vascular compliance through increased arterial and venous transmural pressure. The newer, extended coverage anti-G suits amplify that protection by applying more uniform pressure to the lower body. Thus, the stiffer and less compliant the vascular

system becomes the less it is affected by +G_z.

An additional benefit of the inflated G-suit is the foundation it provides for the AGSM. Figure 7 illustrates the benefits of G-suit inflation for the swine. The left panel is a 60 sec +9G_z exposure without anti-G suit inflation. Note that the animal does very poorly. There are several obvious struggles during the exposure, but very little rhythmic straining. Towards the end of the exposure ELBP and CVP fall well below zero and there is no indication of any straining activity for over 10 sec, indicating loss of consciousness. However, the pressures and flow recover immediately upon reduction of the +G_z load. In contrast, the right panel is an identical +G_z exposure with the same animal, but with inflation of an abdominal bladder anti-G suit, which

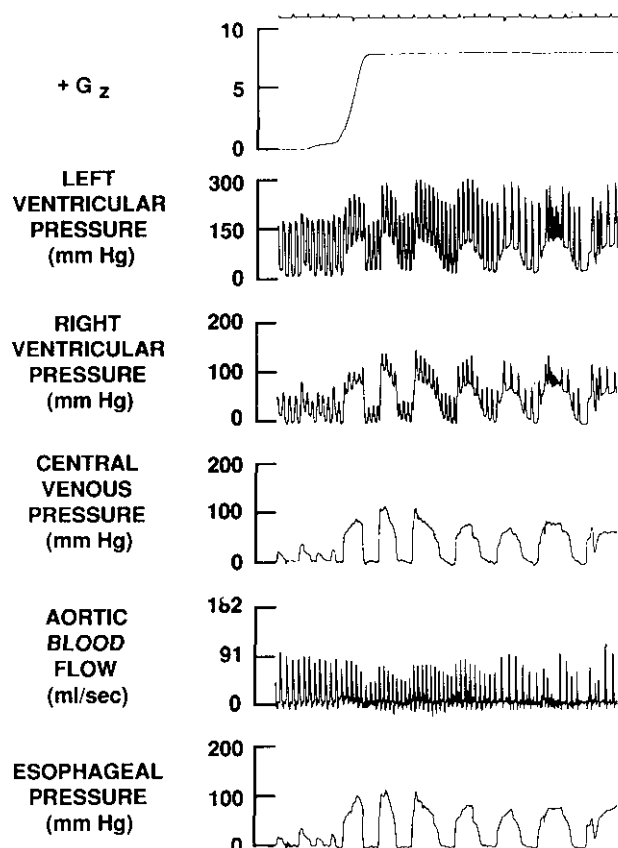

Figure 8. Demonstration of efficient transfer of intrathoracic pressure, as measured by esophageal pressure, into the cardiovascular system.

provides the foundation for performance of the classical, rhythmical, AGSM.

Currently, $+G_z$ protection is provided by: a) the standard 5 bladder G-suit, which has changed very little in design over the past 45 years; b) pressure breathing during $+G_z$ (PBG) in some aircraft; and c) the anti-G straining maneuver (AGSM), which is a very fatiguing physical maneuver. The inflated G-suit provides average relaxed $+G_z$ protection of 5.4 G, while the AGSM, singularly, or in combination with the G-suit can provide variable $+G_z$ protection to $+9G_z$, or greater, depending upon the efficiency and effectiveness of the AGSM and the physical condition of the performer. PBG can reduce the effort level during the AGSM by about 50%, thus decreasing the level of fatigue during $+G_z$.

The transfer of developed intrathoracic pressure into the cardiovascular system during the AGSM is demonstrated in Figure 8 which illustrates the influence of the AGSM on left and right ventricular pressure (LVP and RVP), central venous pressure (CVP) and EP (2). LVP, RVP and CVP were obtained from high fidelity solid state transducers while EP was obtained from an air filled latex balloon catheter. Note the close similarity between the different waveforms. Also note that the sharp rises in LVP, RVP and CVP are the result, almost exclusively, of extravascular intrathoracic pressure generation by the AGSM and thus transmural vascular pressures are minimally affected. The linear relationship between the augmentation of ELBP in response to developed EP during the AGSM in the swine at $+3$, $+5$ and $+7G_z$ is nicely demonstrated in Figure 9 (6).

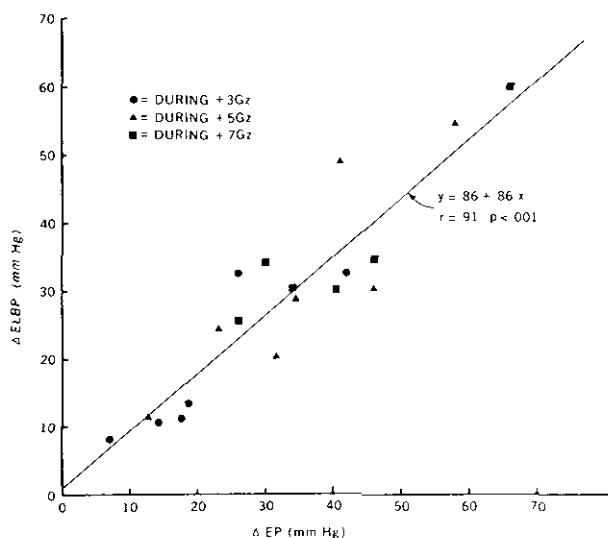

Figure 9. Linear relationship between the response of eye-level blood pressure (ELBP) to changes in intrathoracic pressure (EP).

More recent simultaneous pulmonary artery and aortic blood flow data from the swine demonstrate that during the AGSM output from the left ventricle increases relative to the right ventricle and during the no strain period the opposite occurs (5).

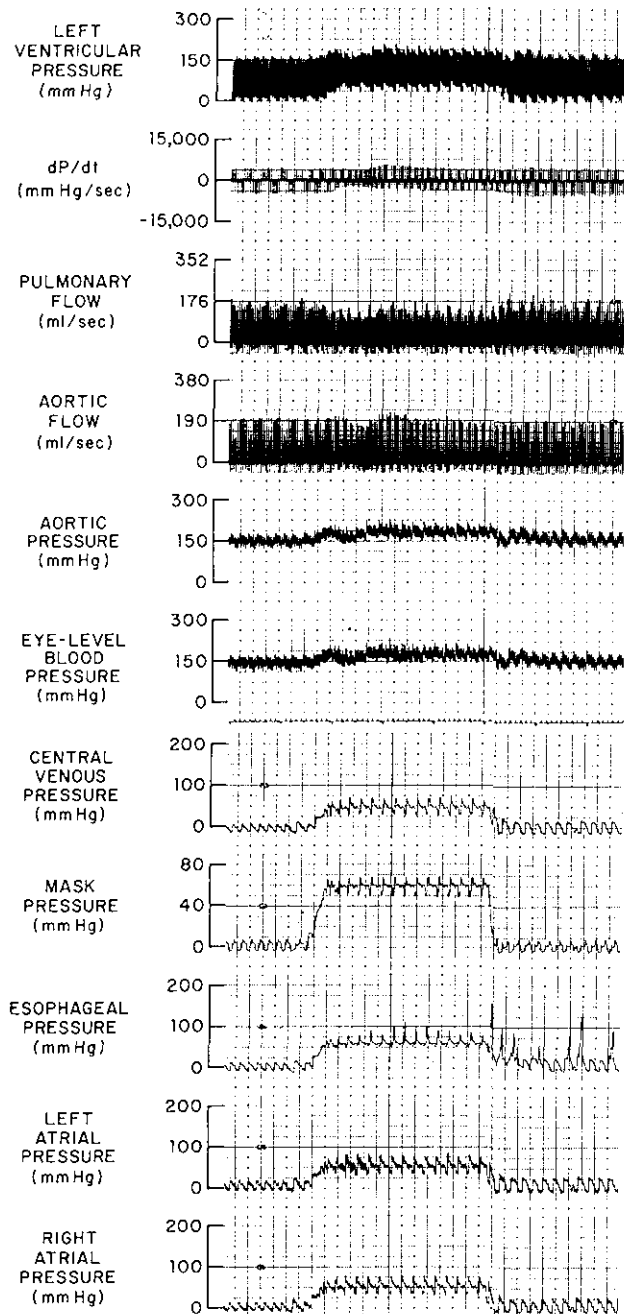

Figure 10. Effect of 60 mmHg pressure breathing at 0Gz.

Thus it appears that during expiration/ inspiration (no strain period) a bolus of blood is moved through the vena cava and right ventricle into the lung but not into the left ventricle, whereas, during the strain the increased intrathoracic pressure forces

blood out of the lung vasculature and through the left ventricle into the systemic circulation while slowing venous return into the vena cava and right ventricle.

Because of the fatiguing effort involved in performance of the AGSM and the continuing loss of pilots and aircraft to G-LOC it has become very important to develop additional techniques and/or equipment for G protection. A very successful G-protective technique, adopted from altitude protection, is pressure breathing during G (PBG). This technique provides balanced pressure (chest counterpressure) to the lungs at a maximum of 60 mmHg at +9Gz. It has been demonstrated that increased intrathoracic pressure from pressure breathing (PB) is transmitted into the intrathoracic vascular system on a 1:1 basis (8). Thus, blood pressure can be expected to rise by 60 mmHg, with an associated rise in G tolerance. The most significant benefit of PBG has been a reduction in fatigue, demonstrated by extended time at G. An additional benefit of PBG has been the ease of obtaining inspiratory air since it is available under pressure, even though, theoretically, the transthoracic pressure should be zero due to the chest counterpressure garment (3). Obviously the phasing of the counterpressure is not perfect, which is advantageous to the user.

Figure 10 illustrates the immediate effect in the swine of PB of 60 mmHg without increased acceleration and without G-suit inflation (4). Mean data from 12 swine demonstrate a reduction of stroke volume and cardiac output from both ventricles and an increase in heart rate (Table 1). The increase in mean aortic blood pressure (AP) was only about 1/2 of mask pressure, probably because of the absence of G-suit inflation. The percentage of transfer of intrathoracic pressure to the cardiovascular system is dependent upon the amount of counterpressure (i.e., legs, torso, arms, etc.), and can be as high as 125% of mask pressure (8).

Table 1 Pressure Breathing at 0 Gz

	Control	Pressure Breathing		
		10 sec	20 sec	30 sec
Peak LVP (mmHg)	152±19	181±26	193±36	195±35
LVEDP (mmHg)	11±9	58±13	61±13	61±10
Peak RVP (mmHg)	45±11	89±17	95±19	93±18
RVEDP (mmHg)	1±8	48±11	50±12	49±10
AP (mmHg)				
systolic	153±13	176±23	180±25	180±22
diastolic	109±14	136±19	139±19	142±21
mean	129±13	153±20	156±20	158±21
CVP (mmHg)				
max	21±7	63±6	65±5	64±5
min	2±9	46±6	49±7	47±7
mean	11±7	54±6	57±6	56±5
EP (mmHg)				
max	12±4	67±3	71±5	71±5
min	-5±4	51±3	54±3	54±5
mean	4±3	59±2	62±2	62±3
MP (mmHg)	6±2	63±2	65±2	64±2
LVSV (ml)	28±10	19±7	20±8	18±7
LVCO (L/m)	4.0±1.1	3.1±.9	3.2±.9	3.0±.9
RVSV (ml)	24±10	17±8	17±7	17±7
RVCO (L/m)	3.7±1.1	2.9±1.0	2.9±.9	2.8±.9
HR (b/m)	149±35	171±36	172±39	175±40

Data are mean ± SD; n=12

It can be seen from these data that the AGSM and PBG are similar in that they both produce intrathoracic pressure which augments cardiovascular pressures, most importantly head-level blood pressure for brain perfusion. The basic differences between these two pressure sources is that the AGSM is an active, fatiguing process which pressurizes the lung parenchyma from without, by respiratory muscle activity, whereas, PBG is a passive process which pressurizes the lung parenchyma from within through the face mask and the trachea.

Another recent improvement in G-protective technology has been the extended coverage anti-G suit (ECGS). The USAF version of the ECGS is the Advanced Technology Anti-G Suit (ATAGS). As shown on the right in Figure 11, this suit covers the entire legs and feet with a continuous bladder for uniform pressurization.

The suit on the left is the current USAF CSU-13B/P anti-G suit. The ATAGS has provided a 60% improvement in G-time tolerance on the centrifuge and a prototype has been well received by test pilots during preliminary flight trials.

The lung is seriously affected by +G_z, resulting in a dramatic ventilation/perfusion imbalance. Simplistically, blood is

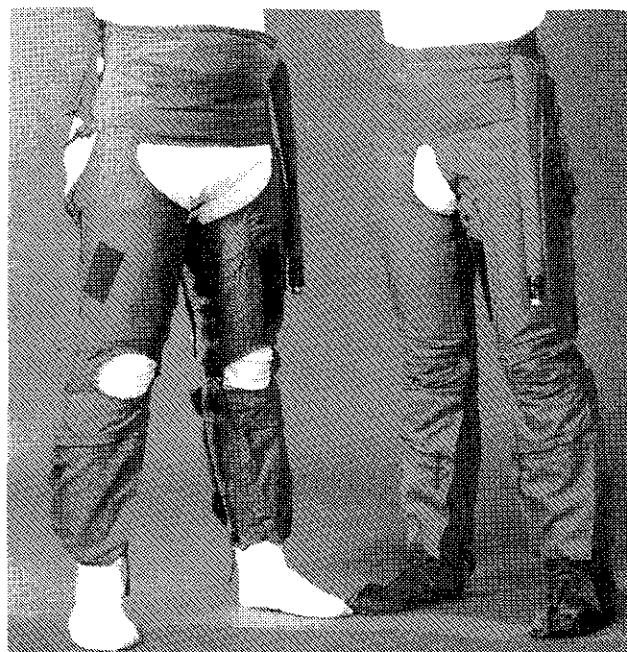

Figure 11. The USAF extended coverage anti-G suit on the right has been labeled the Advanced Technology Anti-G Suit (ATAGS). The suit on the left is the current USAF operational CSU-13B/P anti-G suit.

forced to the base of the lung and air is forced to the apices. Blood oxygenation occurs in the middle region of the lung. In the upper half of the lung capillaries collapse and blood flow stops. During sustained +G_z the increased weight of the blood in the lower lung zone collapses alveoli, and air flow stops resulting in a large right-to-left shunt of venous blood and significant desaturation of arterial blood (10). Figure 12 shows the progressive desaturation of arterial blood mea-

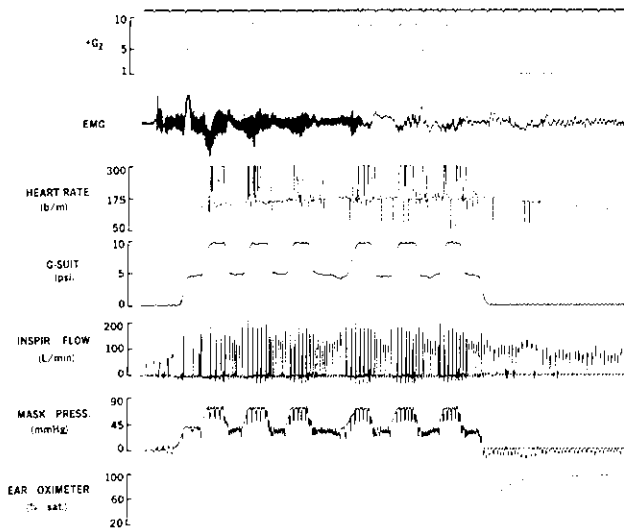

Figure 12. Ear oximeter representation of progressive arterial oxygen desaturation during a +5 to +9Gz centrifuge profile.

sured with an ear oximeter during a +5 to +9G_z exposure. The area of the lung where blood/gas exchange occurs is significantly reduced and limited to the middle zone of the lung. A complicating factor is the inflation of the anti-G suit during +G_z which elevates the diaphragm compressing the base of the lungs even further.

Table 2 5-9 SACM with ECGS

	Without PBG		With PBG	
	Control	5th 9 G	Control	5th 9 G
Peak LVP (mmHg)	153±17	310±38	152±12	316±30
LVEDP (mmHg)	14±6	180±25	12±9	170±49
Peak RVP (mmHg)	48±10	194±52	51±13	171±70
RVEDP (mmHg)	-1±13	150±40	1±11	130±65
AP (mmHg)	131±18	214±32	131±12	238±34
ELBP (mmHg)	125±18	58±20	124±12	73±28
CVP (mmHg)	10±9	138±24	12±10	126±51
EP (mmHg)	6±3	126±20	5±2	94±26
MP (mmHg)	7±0	4±1	7±1	55±5
LVSV (ml)	27±6	11±3	31±9	12±3
LVCO (L/m)	3.9±.9	1.4±.3	4.4±1.4	1.7±.7
RVSV (ml)	23±5	10±7	25±5	14±2
RVCO (L/m)	3.1±.1	1.3±.5	3.5±.9	1.9±.6
HR (b/m)	147±17	140±32	144±10	141±35

Data are mean ± SD; n=5
 ECGS=Extended Coverage G-suit

The swine has proven to be an excellent animal model for acceleration research (7). The swine is dimensionally similar to man and the swine does an excellent, spontaneous AGSM with adequate anti-G suit support. The value of the swine was recently demonstrated when the introduction of PBG into the operational U.S. Air Force was challenged by the aerospace medical community as being potentially hazardous because of high intrathoracic pressure (60 mmHg at +9G_z). Some of their concerns were: barotrauma; pneumothorax; air embolism; excessive transmural vascular pressure; cardiac valvular damage; over dilation of right ventricle following +G_z and PBG resulting in hypertrophy; and, pulmonary hypertension. Using extensive invasive cardiovascular instrumentation in the miniature swine we were able to investigate a number of the aeromedical concerns (4,5). Table 2 illustrates the very high pressure within the cardiac ventricles, the thoracic aorta and the thoracic vena cava during +9G_z, with an extended coverage G-suit (ECGS), and with and without PBG. Figure 13 illustrates the dramatic reduction of LVP, both peak pressure, and minimum pressure (end-diastolic pressure, LVEDP) when intrathoracic pressure (esophageal pressure, EP) was subtracted from peak LVP and LVEDP during the shaded +5 to +9G_z profile. The resultant transmural LVP was more like that observed during strenuous exercise. Thoracic AP responded similarly to maximum LVP when adjusted for EP.

The influence of the AGSM, PBG, and the ECGS on CVP during the +5 to +9G_z profile are shown in Figure 14. Note that when adjusted for EP the transmural CVP is well within normal values. When CVP was separated into strain and no strain segments of the AGSM there was a progressive rise in CVP during the no strain period, with and without PBG, throughout the +5 to +9G_z profile (Figures 15 and 16). The slope of the no strain rise in CVP dur-

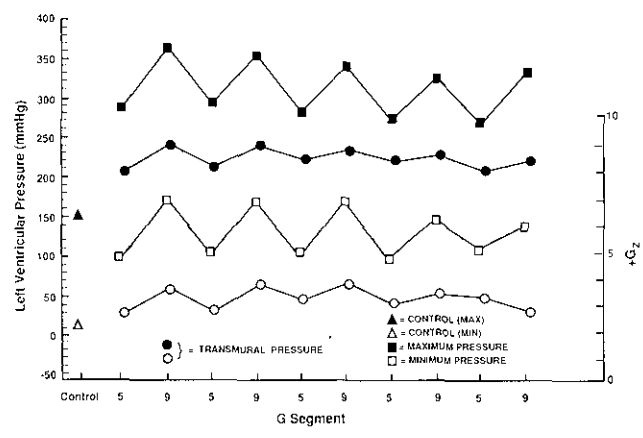

Figure 13. The influence of intrathoracic pressure (EP) on peak LVP and LVEDP during a +5 to +9Gz profile. When LVP and LVEDP were corrected for EP the resultant transmural pressure was significantly lower.

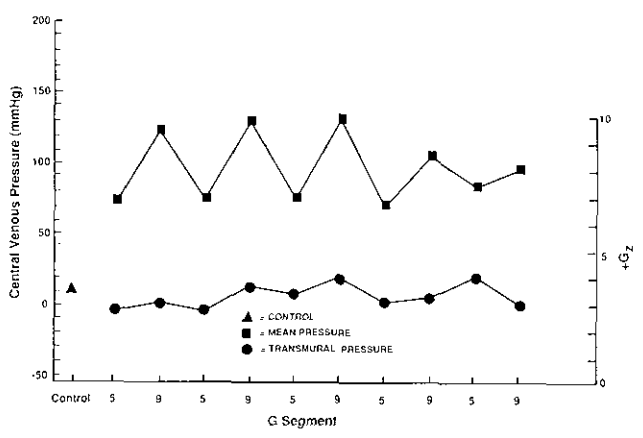

Figure 14. Mean CVP before (closed squares) and after (closed circles) correction for EP during the +5 to +9Gz profile.

ing 9G was significantly ($p=.026$) greater than the 5G slope without PBG. Whereas, the two slopes were the same during no strain with PBG. Again, note that when CVP was adjusted for EP the transmural pressure was within normal values. Peak RVP, RVEDP and LVEDP responded similarly to CVP both with and without PBG.

The data clearly demonstrate that the aeromedical concerns regarding elevated transmural pressure during PBG were unwarranted and that transmural cardiovas-

cular pressures within the thorax were not excessive during +Gz. Thus, the differential pressure across the cardiac valves was also not excessive and valvular damage would not be expected. The generation of much of the increased vascular pressure during +Gz was the result of the supplemental forces of the AGSM, PBG, and the ECGS. Of the three contributing factors, PBG was the least significant. There were no significant differences in the data comparison with and without PBG. Moreover, it has been demonstrated that AGSM-generated intrathoracic pressure can be as much as 2-3 times greater than the current operational PBG maximum of 60 mmHg (2).

The gradual rise in CVP and RVP at 5G and 9G during the +5 to +9Gz profile (Figures 15 and 16) was not related to PBG since it occurred both with and without PBG, nor was it related to the AGSM since the data were from the no strain phase of the AGSM. Therefore, the gradual rise in pressure appeared to be the result of the efficiency and effectiveness of the ECGS through a gradual displacement of blood from below the diaphragm into the chest. The start point of the pressure rise at 5G and 9G and the transmural pressure are higher with PBG (Figure 15) than without PBG (Figure 16). However, the data at the

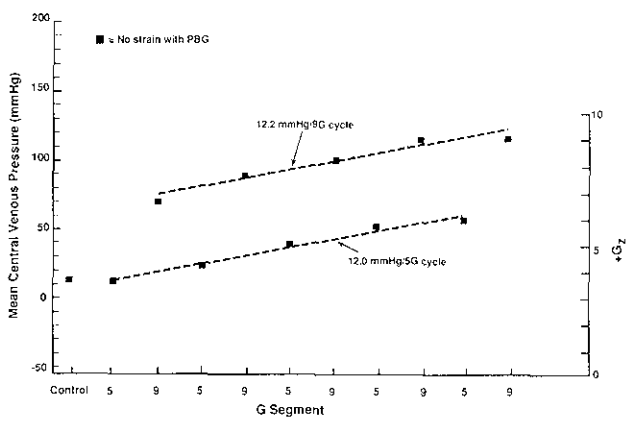

Figure 15. Mean CVP at +5Gz and at +9Gz during the no strain phase of the AGSM, with PBG.

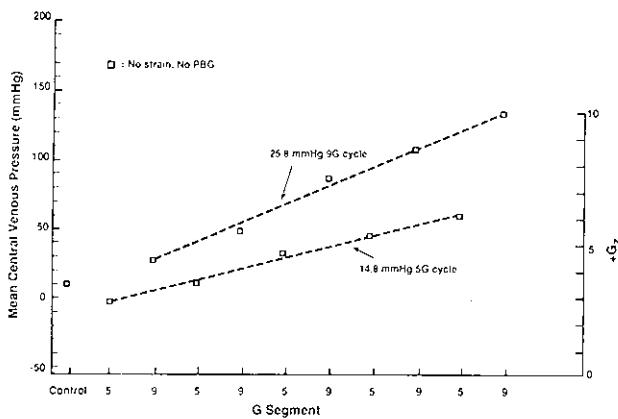

Figure 16. Mean CVP at +5Gz and at +9Gz during the no strain phase of the AGSM, without PBG.

last 5G and 9G plateaus, with and without PBG, were very similar. The fact that transmural pressure did not rise indicated that intrathoracic pressure must have followed the rise in CVP, supporting the supposition that there is a gradual displacement of fluid (blood) into the chest from body areas below the diaphragm. It is unknown whether the slope of the rise in CVP would continue at the same rate if the +5 to +9Gz profile had been extended beyond five 9G peaks.

References:

1. A Textbook of Aviation Physiology. Ed. JA Gillies. Pergamon Press, London, 1965.
 2. Burns, JW. High-G cardiovascular physiology. The Physiologist 35:S131-134, 1992.

3. Burns, JW and UI Balldin. Assisted positive pressure breathing for augmentation of acceleration tolerance time. Aviat. Space Environ. Med. 59:225-233, 1988.

4. Burns, JW, JW Fanton and JL Desmond. Hemodynamic responses to pressure breathing during +Gz (PBG) in swine. AGARD-CP-516, 10-1 to 10-5, 1991.

5. Burns, JW, JW Fanton and JL Robinson. The influence of the AGSM, PBG, and anti-G suit inflation on thoracic hemodynamics during +Gz in swine. J. Gravit. Physiol. 1:P48-51, 1994.

6. Burns, JW, MJ Parnell and RR Burton. Hemodynamics of miniature swine during +Gz stress with and without anti-G support. J. Appl. Physiol. 60:1628-1637, 1986.

7. Burton, RR. Positive (+Gz) acceleration tolerance of the miniature swine: Application as a human analog. Aerospace Med. 44:294-298, 1973.

8. Ernsting, J. Some effects of raised intrapulmonary pressure in man. AGARDograph 106. London, McKay, 1966.

9. Fundamentals of Aerospace Medicine. Ed. RL DeHart, Lea & Febiger, Philadelphia, 1985.

10. Glaister, DH. Pulmonary considerations of high sustained +Gz acceleration and G protection. Aeromedical & Training Digest. 4:39-43, 1990.

11. Rushmer, RF. The effect of positive radial acceleration on the intrarectal pressure. J. Aviat. Med. 18:96-101, 1947

NEGATIVE TO POSITIVE GZ ACCELERATION TRANSITION

Wing Commander A.R.J. Prior BSc PhD MB BS

Royal Air Force School of Aviation Medicine,
 Farnborough, Hampshire, GU14 6SZ. UK

SUMMARY

Sustained negative Gz acceleration is an uncommon stress; it is poorly tolerated by the pilot, the airframe is normally stressed to only -3Gz and operationally there is no defined advantage for performing such a manoeuvre. However, during repeated pulls of high +Gz it is common practice to push negative Gz whilst regaining aircraft energy prior to another high G turn. During the period of negative G, which might be for only 1 or 2 seconds, there is the rapid development of bradycardia, peripheral vasodilation and the likelihood of cardiac arrhythmias. In this physiological state the pilot then pulls positive G giving rise to profound changes in cerebral perfusion and a marked reduction in G tolerance. The use of anti-G trousers reduces the magnitude of this effect but there remains a significant lowering of G tolerance which, it is suggested, might contribute to the genesis of G-induced loss of consciousness.

INTRODUCTION

Studies into the physiological changes and the effects of sustained negative Gz acceleration on aircrew have not received nearly as much attention as those associated with positive Gz acceleration. There are several reasons for this relative neglect. Aircrew generally regard -Gz exposure to be dangerous, as do their medical advisors, and normally only sanction manoeuvres which give rise to -Gz as an emergency procedure. Indeed, in some air forces such manoeuvres are prohibited. Consequently, there has been little incentive to study the effects of an environment to which aircrew are not normally exposed although investigations into its therapeutic effects were carried out many years ago, figure 1. Symptoms appear at relatively low levels of -Gz, are particularly unpleasant and impair function more readily than corresponding levels of positive Gz acceleration. Furthermore, the structural limits for most fast-jet airframes are commonly set to -3Gz and the operational tactics employed in-flight have evolved taking this into account.

However, there are situations in flight in which negative to positive Gz acceleration transitions occur quite commonly. Depending on the aircraft type, a procedure is adopted where, following a high G excursion, the aircraft needs to regain energy prior to a further high G turn. In gaining energy there is frequently a transient exposure to -Gz followed by the next +Gz excursion. Verbal reports from aircrew indicate that the duration of -Gz is brief, only 2 seconds or so, but there has been no study to confirm either the duration or the extent of -Gz exposure during such manoeuvres (to the knowledge of the author).

A further confounding factor which has contributed to the lack of research effort directed toward -Gz acceleration, and certainly -Gz to +Gz transitions akin to those described in flight, has been the fact that most centrifuges, until recently, have required the re-orientation of the subject in the gondola in order to provide the -Gz acceleration exposure. This has been achieved either by pre-positioning or by the rotation of the subject once the centrifuge is in motion. Both ploys are unacceptable as the baseline physiological state of the subject is either -1Gz or a positive acceleration in excess of one. It is only with the advent of centrifuges with actively controlled, gimballed gondola systems that -Gz acceleration is readily achievable and reproducible. Even with such a centrifuge the subject is exposed to Gy acceleration during a transition from -Gz to +Gz and so is unlike the airborne situation as well as creating a risk of neck injury. As is often the case in acceleration research, the centrifuge has its limitations and the only way in which the research can be carried out satisfactorily is to perform it in-flight using an aircraft with suitable engineering and physiological instrumentation.

PHYSIOLOGY OF -GZ EXPOSURE

Cardiovascular effects

The physiological disturbances arises mainly in the cardiovascular system as a result of the inertial forces

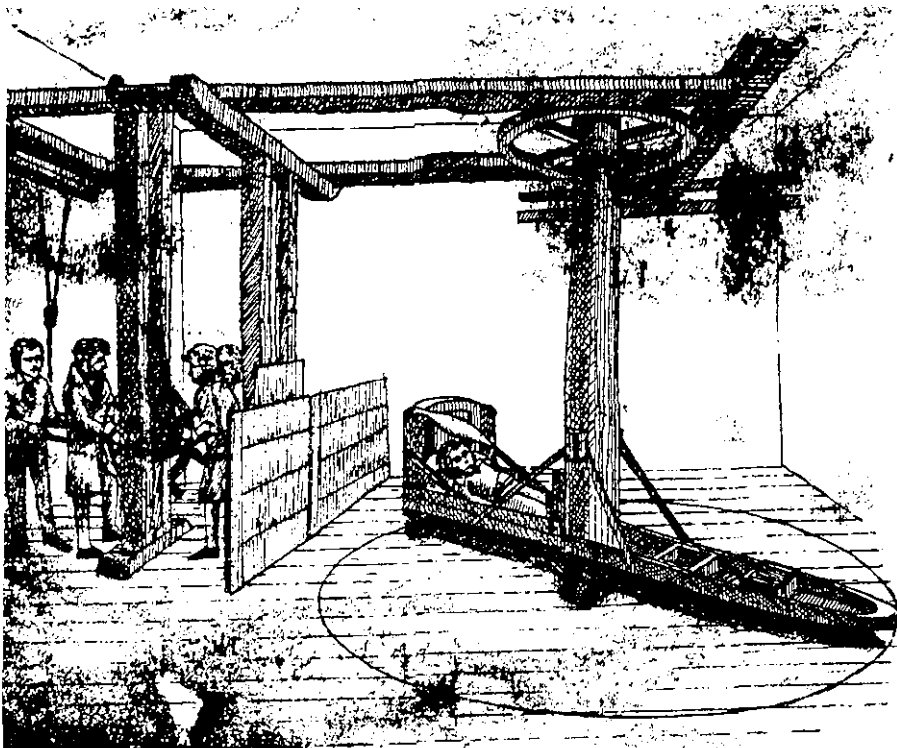

Figure 1. A psychiatric patient is exposed to negative G on the centrifuge at La Charite in Berlin, 1814 - 1818.

causing a rise in vascular pressure in the upper thorax, neck and head and a reduction in the vascular pressures at levels below the heart in the abdomen and lower limbs. There results a tendency to displace blood towards the head. Initially, mean arterial blood pressure rises by 20-25 mmHg/G at eye level, as a result of hydrostatic effects, so that at -3Gz the pressure rises to some 170 mmHg. Several seconds later the venous pressure rises following venous compartment filling and distension so that once equilibrium is reached, the venous pressure at eye level at -3Gz rises to over 100 mmHg. The high value for venous pressure arises because the effective length of the venous column is from the level of the head to the diaphragm under conditions in which there is distension of the venous compartment. This is unlike the situation seen during positive Gz acceleration where the point of venous hydrostatic indifference is located at the level of the right atrium.

Upon exposure to -Gz acceleration, the large and rapid rise of arterial pressure in the neck stimulates the baroreceptors of the carotid sinus causing a reflex bradycardia and generalised arteriolar vasodilation. The stretch of the wall of the carotid sinus gives rise to an intense stimulation of the baroreceptor with a discharge of vagal efferent impulses which, in turn, generate a bradycardia and an increased likelihood of a variety of cardiac arrhythmias, figures 2 & 3. The rhythm disturbance may simply take the form of a prolongation of the P-R interval or, if more

severe, a complete dissociation of atrioventricular activity, with ectopic beats and asystole. Arrhythmias are common during levels of -Gz greater than -1G and 5-7 second periods of asystole are not uncommon at -2.5Gz.

The pressure rise within the vessels of the brain resulting from negative Gz acceleration are balanced by a similar increase in the pressure of the cerebrospinal fluid, hence the transmural pressure remains unchanged and there is no risk of rupture of the vessels within the skull. With progressive venous engorgement and a reduction of cardiac output produced by carotid sinus stimulation, the arteriovenous pressure difference across the cerebrovascular bed falls leading to reduced cerebral blood flow and the symptoms of mental confusion and the possible loss of consciousness. The latter generally ensues following prolonged cardiac asystole or a slow ectopic rhythm both of which reduce cardiac output and further compromise cerebral blood flow.

"Red-out" or "red-mist" is a visual symptom experienced during -Gz acceleration and is analogous to grey-out or black-out with positive Gz acceleration. However, its occurrence is somewhat inconsistent to the extent that, in the author's experience, it has never been experienced first hand nor have any subjects participating in negative G trials, 14 in total, ever reported it. Nevertheless, the literature records

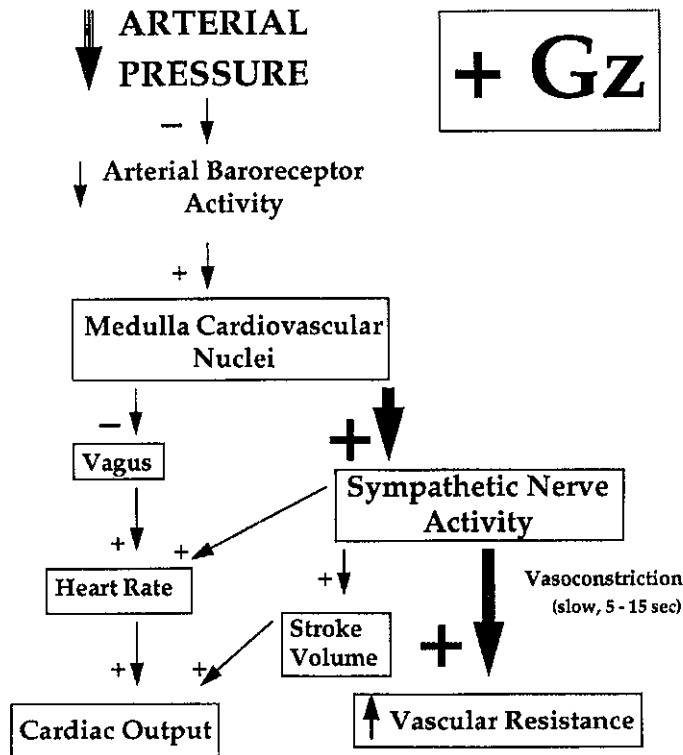

Figure 2. Reflex response to positive Gz acceleration.

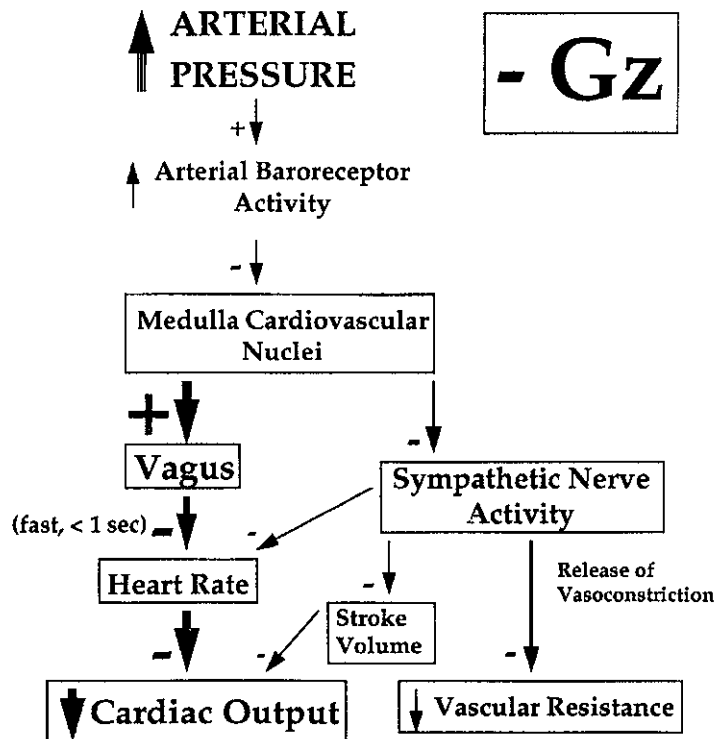

Figure 3. Reflex response to negative Gz acceleration.

symptoms of indistinct, blurred vision followed by loss of contrast and loss of vision. At this stage "red-out" sometimes appears. It has been observed that if the subject tries deliberately to keep his eyes wide open during negative G then most symptoms could be alleviated. This has given rise to the hypothesis

that the visual disturbance is due principally to the lower eyelid gravitating over the cornea leading to a mechanical visual occlusion and a redness appearing as bright light shines through the eyelid (Ryan, 1950; Lombard et al, 1948).

Pulmonary Effects

As with positive acceleration, on exposure to -Gz the regional distribution of ventilation and blood flow are changed. In negative acceleration the apex of the lung is better ventilated and perfused than the basal region. However, as the level at which pulmonary vascular pressure remains unchanged during changes in the Gz acceleration vector is at the junction of the middle and basal thirds, most of the lung remains perfused under negative acceleration. -Gz acceleration causes closure of the terminal airways, trapping gas in the apical regions, so generating a right to left shunt and a consequent desaturation of arterial oxyhaemoglobin.

Negative Gz acceleration also produces an headward displacement of the diaphragm so reducing vital capacity and the functional residual capacity. Overall, pulmonary ventilation is reduced which further compromises arterial oxygen saturation.

Tolerance

Generally speaking, negative acceleration is poorly tolerated. It is a most unpleasant experience in which there is a sensation of gross fullness in the head, difficulty with breathing, oedema of the soft tissues of the face, petechial and sub-conjunctival haemorrhages and loss of consciousness. Most individuals can tolerate -2Gz for 5 minutes and -3Gz for 10 - 15 seconds. At -5Gz the tolerable exposure time falls to no greater than 5 seconds. With experience, and possibly some degree of adaption, it is possible to tolerate -6Gz for short periods of time without immediate problems. This is seen in aerobatic display pilots although there is anecdotal evidence of gross dysarthria and ataxia following intense sessions of aerobatic flying in which negative Gz is a prominent feature.

NEGATIVE TO POSITIVE GZ ACCELERATION TRANSITIONS

Methods

In order to generate -Gz/+Gz exposure either a suitably gimbaled and controlled gondola on a high performance centrifuge must be used or the studies must be carried out in the air using an aircraft adequately stressed for such manoeuvres. However, recently a "coriolis acceleration platform", normally employed for vestibular research, has been adapted successfully so as to produce -Gz/+Gz transitions by changing the orientation of the subject whilst rotating the device at constant angular velocity (Banks et al,

1994). The device has a diameter of 6m and although reported to be well tolerated by participating subjects, the short radius does create a relatively large gradient of acceleration along the length of the subject so that the acceleration at the head differs considerably from that at the feet.

Centrifuge based experiments

In 1991, Lehr, Prior and Langewouters used the centrifuge at Konigsbruck, former E. Germany, to test the hypothesis that the relaxed tolerance to +Gz acceleration was adversely affected by a period of preceding -Gz acceleration exposure. Verbal reports from fast-jet and civilian aerobatic aircrew suggested that under some circumstances a manoeuvre in which "pushing" G was immediately followed by "pulling" G caused a dramatic reduction in G tolerance manifest by a profound, and sometimes unexpected, blackout.

Initially, the relaxed positive G tolerance of each subject was established using the criteria of 60% peripheral light loss as the end-point. Each subject then underwent either a 30, 16 or 2 second period of negative G exposure immediately followed by a transition to +Gz acceleration at a rate of 1G/s. Three levels of negative acceleration were used, -1.0, -1.4, and -1.8 Gz and the relaxed G tolerance from each of these -Gz baselines was obtained. Head and heart level arterial blood pressure were recorded using 'Portapres', a non-invasive device using a photoplethysmographic technique to monitor digital artery blood pressure and referenced to either head or heart level.

Figure 4 shows a typical trace of heart level arterial blood pressure, and the ECG, recorded from a subject exposed to -1.8Gz for 30s followed by a transition to 2.4Gz. The striking bradycardia upon exposure to negative G can be seen to occur within 2 or 3 beats followed by a rhythm disturbance and, towards the end of the 30s period, a rise in heart rate. Heart level arterial blood pressure falls progressively throughout the period of negative G exposure as generalised peripheral vasodilation and a fall in cardiac output ensues. Upon transition to 2.4Gz the heart rate increases after approximately 5s as does the heart level arterial blood pressure. Figure 5 shows the same centrifuge run but uses the capability of Portapres to reference arterial blood pressure measurement to eye level by means of its height correction unit. Here the profound influence of the hydrostatic pressure component of arterial blood pressure can be seen clearly as the applied acceleration changes from a negative to a positive value. Equally dramatic is the

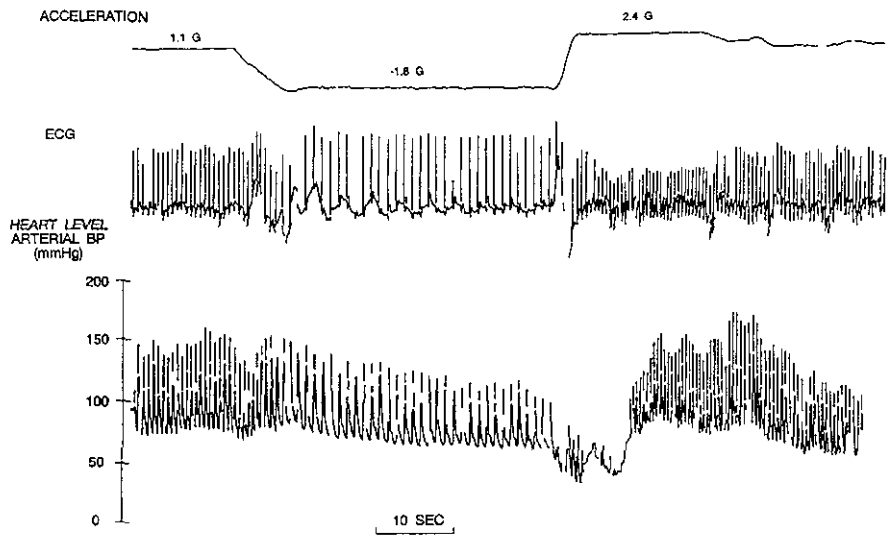

Figure 4. Typical heart rate and heart level arterial blood pressure response to -Gz acceleration. Negative Gz produced using the Konigsbruck centrifuge.

bradycardia induced by -Gz acceleration.

The normal relaxed G tolerance to +Gz acceleration of each subject was measured and compared to the G tolerance immediately following a period of negative G exposure. The meaned responses of 8 subjects are shown graphically in figure 6 for -Gz exposures lasting 2 and 16 seconds. All levels of preceding negative G in the range -1.0 to -1.8 Gz, for both 2 and 16 seconds, result in a reduction of relaxed G tolerance although the greater the duration

and magnitude of negative G the greater the reduction in positive G tolerance. It should be noted that -1.0 Gz for 2 seconds is sufficient to cause an average reduction in G tolerance of approximately 0.7 G. Such a negative / positive G manoeuvre is well within the realms of routine, operational, fast-jet flying and the results of this experiment suggest that pilots, in these circumstances, might well expect some reduction in their normal ability to tolerate G. Further, it can be postulated that negative / positive G manoeuvres might predispose to G-induced loss

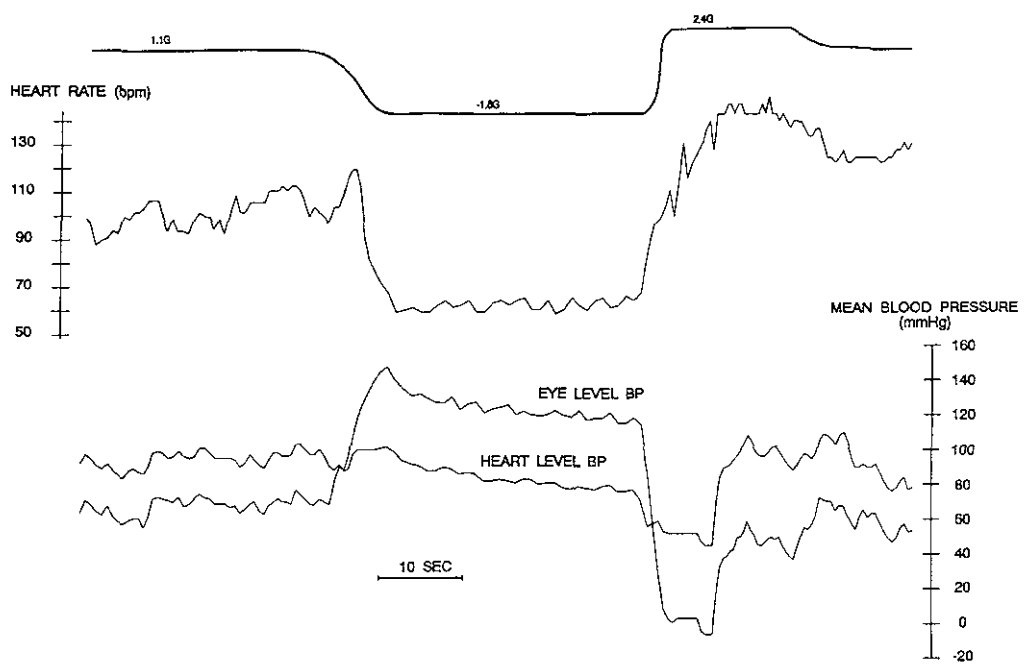
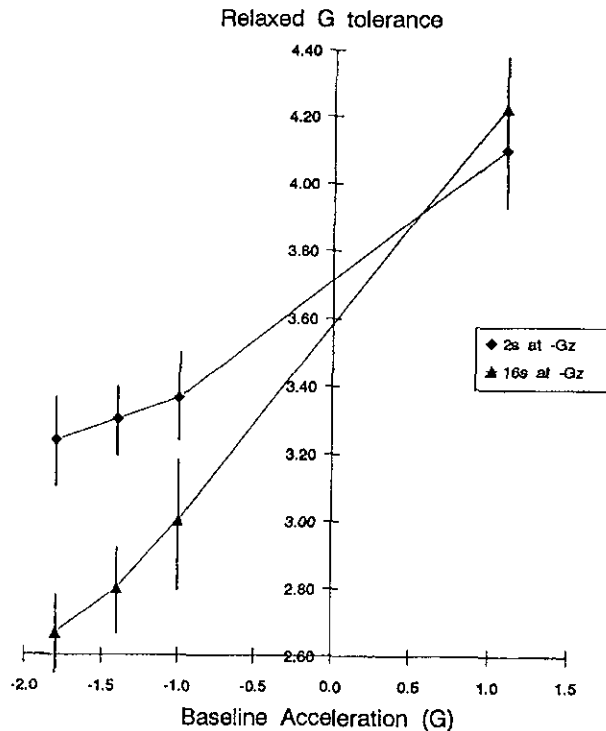

Figure 5. Portapres output recorded during the same acceleration profile as shown in figure 4. The profound changes in heart rate and eye-level arterial blood pressure can be seen clearly.

Figure 6. Mean responses of 8 subjects showing the decrement in relaxed G tolerance as a result of previous exposure to negative Gz acceleration.



of consciousness. However, all the centrifuge work described here was performed on unprotected subjects, that is they were not wearing anti-G trousers, and it is possible that in the operational scenario the anti-G trousers offer protection against the effects of negative to positive G transitions. It is with this in mind that a series of in-flight investigations were performed, firstly to see if the centrifuge results held true in the air and secondly to assess the protective value of anti-G trousers under these circumstances.

In-Flight Experiments

The conduct of in-flight experiments of this nature poses several problems as the aeroplane cannot be regarded simply as a centrifuge substitute. With an experienced pilot, and with practice, each acceleration excursion, or combination acceleration profile, can be reproduced with reasonable accuracy but at best there is an error of +/-0.2 G. Moreover, the acceleration onset rate, although very reproducible, cannot be demanded by specifying a particular value. It is largely a case of accepting what is possible for a given manoeuvre. There is also a finite, comparatively short time available for each sortie, so limiting the number of acceleration profiles which can be performed, and also a limit on the number of sorties that can be undertaken within a reasonable period of time. In this particular experiment there is the additional problem of assessing a G tolerance end-point without the use of either randomly illuminated fixed lights or a light

bar. It is for these reasons that the negative to positive G work in-flight was performed in a slightly unconventional manner.

The Portapres blood pressure monitor was mounted in the ejection seat personal survival pack and the hydrostatic pressure compensating transducer placed at neck level by means of a thin Velcro collar. A set of +Gz acceleration excursions were performed which started at 3.0 G and incremented by 0.5 G steps until the subject reported a substantial greyout. Negative to positive G profiles were then flown with the intention of applying negative G followed immediately by +3.5 Gz for 15 seconds at negative G levels of -0.5, -1.0 and -2.5 G for 2 and 10 seconds durations. The procedure was repeated for the conditions of inflated and uninflated anti-G trousers achieved by either enabling or disabling the aircraft anti-G valve. Thus each subject performed approximately 6 +Gz profiles followed by 12 negative to positive G transitions.

In order to gain an estimate of relaxed G tolerance the minimum neck level systolic arterial blood pressure occurring over any 5 second period during an acceleration profile was measured. This measurement was made for each of the initial set of +Gz excursions and compared with those resulting from 3.5 Gz preceded by negative G. If the minimum arterial blood pressure was, for example, 60 mmHg during 3.5 Gz preceded by -1.0 Gz and also 60 mmHg

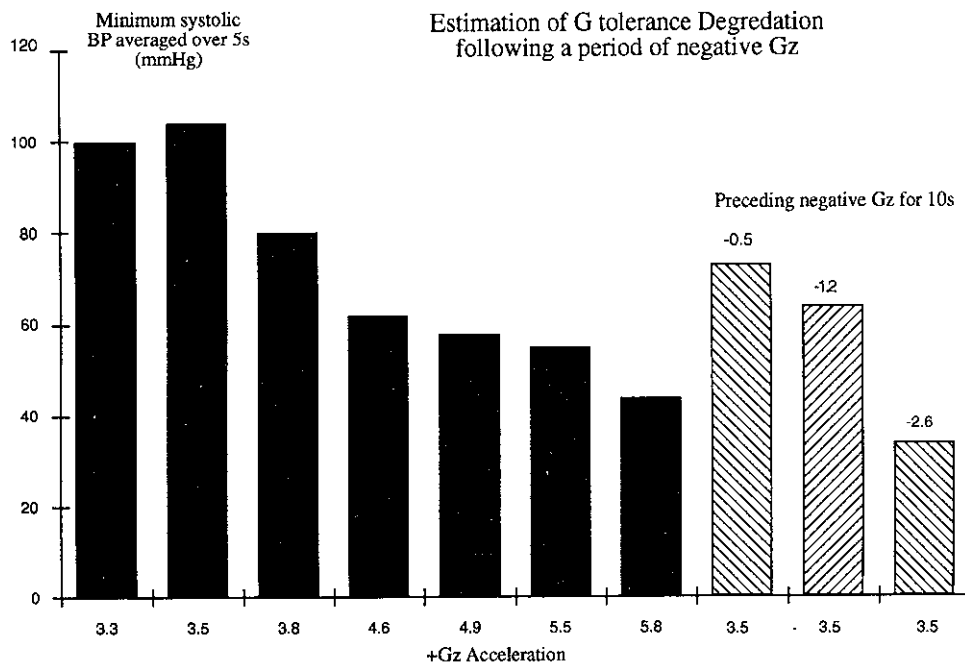
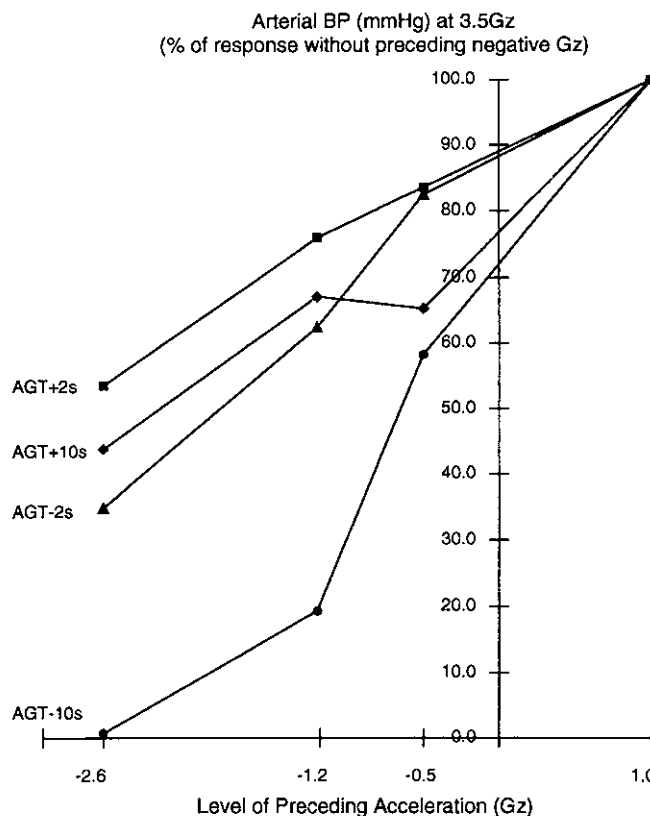

Figure 7. Mean responses of 6 subjects showing the minimum systolic blood pressure occurring during either +Gz excursions or +Gz excursions preceded by 10 seconds of -Gz.

during 4.6 Gz without preceding negative G, then it was estimated that G tolerance had decreased by 1.1G as a result of negative G being applied before a +Gz excursion. If the minimum arterial blood pressure values did not match exactly, then a linear extrapolation between acceleration values was performed.

Typical results are shown in figure 7 and the mean results of 6 subjects for each of the levels of preceding negative G, for 2 or 10 seconds and with or without anti-G trouser inflation, are shown graphically in figure 8. In all cases a period of negative G immediately before pulling positive G results in a more profound fall in arterial blood pressure and, by

Figure 8. Mean responses of 6 subjects showing the fall in arterial blood pressure at 3.5 Gz expressed as a percentage of the response without preceding negative Gz. The use of anti-G trousers (AGT+) during either a 2 or 10 second exposure (AGT+2s, AGT+10s) attenuates but does not abolish the fall in blood pressure.



inference, a reduced G tolerance. This is true regardless of the short duration of applied negative G or whether anti-G trousers are operative.

CONCLUSIONS

The effect of preceding negative G upon relaxed G tolerance is substantial and is operationally significant even when the duration of negative G is only 2 seconds. The effects are reduced by anti-G trousers but by no means abolished. It is possible that G-induced loss of consciousness might more readily occur under these circumstances and it is suggested that the investigation of such incidents, both prospective and retrospective, include an enquiry of the presence of preceding negative G.

REFERENCES

1. Banks RD, Grissett J D, Turnipseed G T, Saunders P L and Rupert A H. The "Push-Pull" effect. *Aviat. Space Environ. Med.* 1994; 65:699.
 2. Lehr A K, Prior A R J, Langewouters G, Ullrich B, Leipner H, Zollner S, Lindner P, Pongratz H, Dieterich H A and Theisen K. Previous exposure to negative Gz reduces relaxed +Gz tolerance. *Aviat. Space Environ. Med.* 1992; 63:405.
 3. Lombard C F, Roth H P and Drury D R. The influence of radial acceleration (centrifugal force) on respiration in human beings. *J. Aviat. Med.* 1948; 19:355.
 4. Ryan G E, Kerr W K and Franks W R. Some physiological findings on normal men subjected to negative G. *J. Aviat. Med.* 1950; 21:173.
-

SELECTION AND SPECIAL PHYSIOLOGICAL TRAINING OF FLYING PERSONNEL TO HIGH +G_z-MANEUVERABLE FLIGHTS — MAIN CONCEPT

Stupakov G.P., Khomenko M.N.

Air Force Institute of Aviation and Space Medicine
 Petrovsko – Razumosvskaja Avenue 12
 Moscow A-83
 Russia 125083

Abstract

For ensurance of the complete and efficient protection of flyers from exposure of high-sustained and rapid onset rate +G_z-acceleration profiles, together with administration of modern sophisticated counter-G technical appliances the important role plays individual physiological tolerance of flyer to the effects of high level +G_z-stress.

There has been verified the necessity of practical implementation of methods of determination of +G_z-acceleration tolerance to high-sustained +G_z-stress for selection, carrying-out of special physiological preparation of flyers in order to magnify their tolerance to such effects.

There have been presented the results of study of health and special physiological preparedness on pilot's individual tolerance to high-sustained +G_z-accelerations. There are disclosed the procedure and criteria of determination of pilot's ability to tolerate high level +G_z-accelerations in centrifuge tests for selection to transition and mastering the high performance fighter-aircrafts of type MIG-29 and SU-27.

There has been proved the possibility of individual pilot's tolerance to high sustained +G_z-acceleration prediction; based on data of statoergometric functional loading test on special physical trainer "Statoergometer".

For enhancement of flyers' tolerance to high-sustained +G_z-acceleration there has been proposed the complex of means and ways of special physiological preparation, involving carrying-out of ground and simulator training, course of physical training exercises on special trainers, realization of training centrifugation runs and special inflight training in aerobatic sorties.

There have been analyzed the methodological particularities of carrying-out and efficiency of various kinds of above mentioned special preparation of flyer and discussed the probable prospective ways of its further improvement.

* * *

Enacting in practice of new generation fighter aircrafts, which possess the top level performance capabilities, has significantly increased the requirements to flyer's tolerance limits. The flyer's endowment to sustain the effects of +G_z-stress is one of the most important factors, determining his combat preparedness and safety of agile maneuverable flight.

The experimental investigations and experience in transition to high maneuverable fighter aircrafts have suggested, that it is impossible to guarantee the complete and efficient protection of flyer from high leveled and intense +G_z-accelerations by exclusively new anti-G technical equipments, such as upgraded anti-G suit, positive pressure breathing, supination of pilot's seatback.

The important role plays also individual physiological endurance of pilot to high sustained +G_z-forces.

It was revealed, that significant importance may have development and implementation in practical work of adequate methods of HSG-tolerance evaluation in flyers, aimed at selection and procurement of means and ways for special physiological preparation of flyers to boost their ability to withstand the adverse effects.

In this lecture there have been presented the main results of long-standing scientific investigations and efforts of research workers at Russian Air Force Institute of Aviation and Space Medicine, dedicated to substantiation of methodological approaches for assessment of high +G_z-level tolerance in flying staff and special physiological training to flights with intense +G_z-accelerations.

1. The methods of determination of flyers' tolerance to high sustained +G_z

The proposed methods of flyers' tolerance prognostication to high leveled +G_z-accelerations embrace two directions.

The first — examination of flyers, piloting the high performance aircrafts, in centrifugation runs.

The second — examination on "Statoergometer" physical stand.

To check the flyers' state on centrifuge there has been validated the methodology, which allows:

- to simulate the main parameters of $+G_z$ accelerations (peak, onset rate, duration of action), which flyers face in intense maneuvering of fourth-generation fighter-aircrafts;

- to disclose the level of pilot's adaptive capability and existence of any hidden pathology under exposure of complex ACM profiles with application of standard anti-G suit;

- sufficiently precise to estimate flyer's individual tolerance to effects of high sustained $+G_z$ and prognosticate its durability in real flight conditions.

In the process of centrifuge examination the flyers have been subjected to the effects of two complex profiles of simulated air combat maneuvering, while using the standard anti-G garment (see Figure 1). The first profile consists of serial $+G_z$ -acceleration peaks at 4,0; 6,0 and 7,0 G each with duration of 15 seconds and onset rate equal to 1 G per second. Before reaching the every stage of $+G_z$ -acceleration profile and between neighboring peaks there is maintained during 15 s the plateau at 2 G. In case of good tolerability of $+G_z$ -accelerations exposure there has been conducted the repeated centrifugation of the same testee-pilot, approximately in 5—7 minutes after completion of the first one with increasingly alternating peaks SACM at 5,0; 7,5 and 8,0 G of analogous duration and onset rate. The used in presented procedure principle of stepped increment of repeated action of $+G_z$ -forces enables to warrant the maximal safety of carried-out investigation and simultaneously renders the rehearsal effect.

The estimation of individual tolerance of flyer to complex profile SACM has been done with taking into consideration of reached $+G_z$ -value. The changes of physiological indicators should not exceed some predetermined values, that is confirmed by absence of pathological aberrations of ECG, visual disturbances and stabile value of blood pressure (not lower than 40 mm Hg) in vascular arterial bed of ear lobe.

The explorations have shown, that flyers' individual tolerance to high $+G_z$ -accelerations mainly depends on the state of their health and psychophysiological and physical preparedness to such $+G_z$ -stresses.

The lowered tolerance to high $+G_z$ -accelerations at primary centrifugation in healthy flyers' population has been registered an average at 22,6% of cases. The persons with various diseases, as a rule, have lowered tolerance to high-level $+G_z$ -accelerations.

Among pilot population those, who are suffering from the cardio-vascular, gastrointestinal, nervous as well as urological diseases, approximately one half (50%) are characterized by lowered tolerance to high $+G_z$ complex profile. However, in majority of health pilots and pilots, having some diseases, the lowered tolerance to high-peak $+G_z$ -acceleration is mainly caused by insufficient psychophysiological and physical preparedness to counteract the unfavorable effects of hypergravitational forces.

These flyers do not possess in adequate degree the mandatory skills of protective, anti-G straining muscular procedures, and especially breathing anti-G strengthening. They are poorly familiarized with specific features of anti-G suit exploitation, they are also insufficiently trained in self-control procedures to ensue its psychophysiological state under exposure of intense $+G_z$ -accelerations.

Therefore, the urgent tasks in a system of special preparation of flying personnel, directed to heighten its tolerance to high-peak $+G_z$ -accelerations, are familiarization with peculiar features of high level $+G_z$ -submission on human organism as well as efficient elaboration of protective skills and managements.

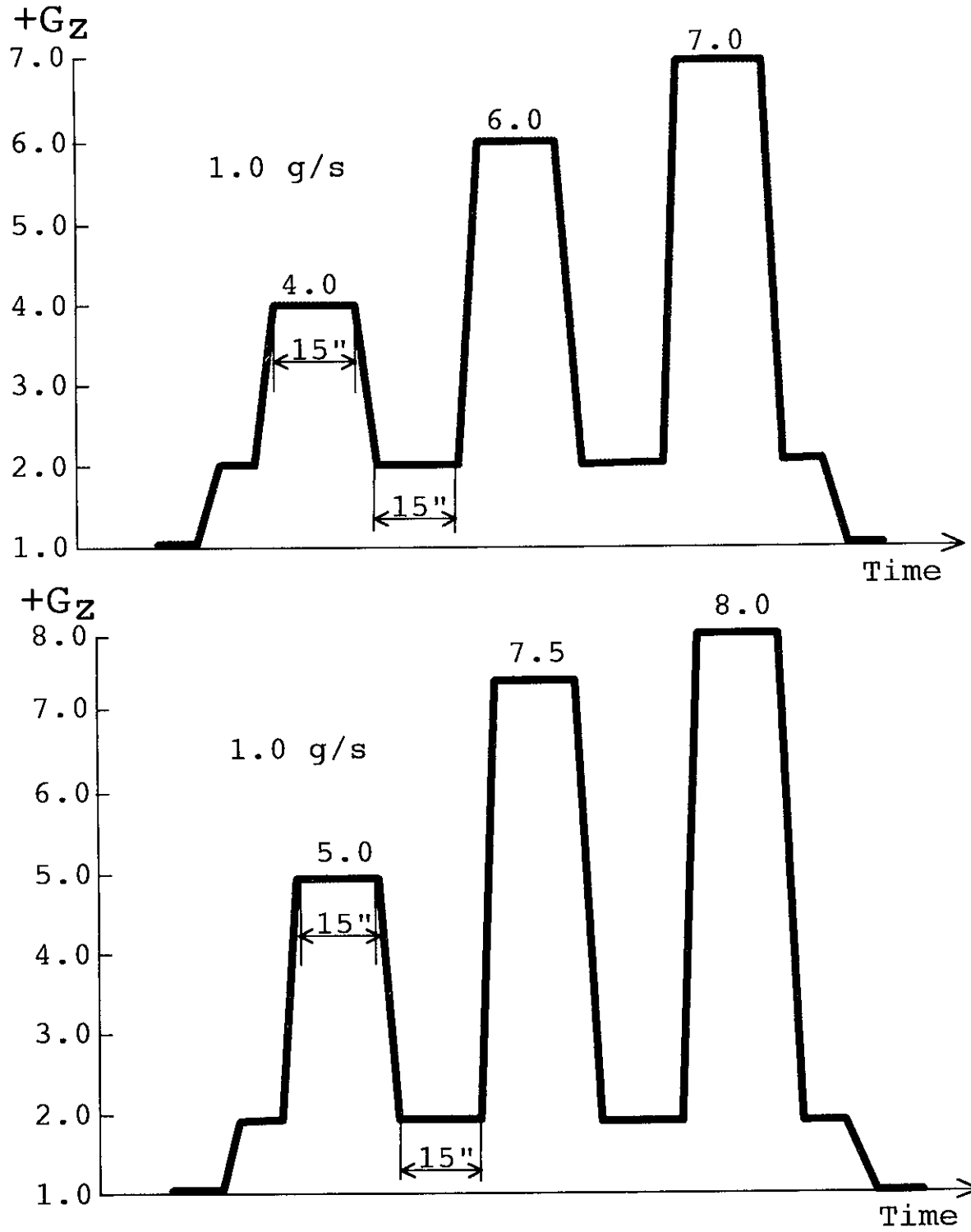

Fig. 1. +G_z - acceleration regimens for medical investigation and selection of pilots on centrifuge expert run

On a level with centrifuge testing of flying staff, the great importance should be attached to development of special loading tests, enabling to prognosticate the flyer's individual tolerance to high sustained +G_z-levels.

It was established in our experiments early, that under exposure on human organism of intensified +G_z-accelerations at 8—9 +G_z with duration intervals up to 30 s, the muscular efforts of legs on pedals, while exerting anti-G straining maneuvers, may reach 260—280 kG-power. This makes possible to improve the hemodynamics of upper body

parts and head at the expense of blood pressure raising. So, the individual tolerance of human to large scaled $+G_z$ -accelerations in much degree depends on its ability to develop and maintain protractedly the static strengthening of legs' and abdominal press muscles. To this relation for prognostication of flyer's individual $+G_z$ -stress tolerance we have worked out special functional loading test with static physical exertion, which is called as Statoergometric test.

This test is carried out on special gear, which was devised and constructed as "Statoergometer" (Figure 2). It consists of seat on a metal basement with standard flyer's restraint and fixation belt system, pedals with foot supporting surfaces and strain-gauge indicator, measuring static muscular strengthening of tested flyer.

Stand imitates the typical working posture of flyer in fighter's cockpit and feet pressure on pedals for ensurance of protective anti-G straining maneuver. The apparatus provides the possibility of individual fitting of pedals' position in dependence on pilot's accomplished standard angle of knee joint flexion. The force-measuring indicator gives to flyer and standing near him aviation physician the information about exercised by both legs of testee person value of muscular strengthening.

The statoergometric test is performed as follows. After appending the electrocardiographic sensor the test-subject has fixed himself to backseat with harness system. Before to start the loading test it is necessary to install with help of special goniometer and pedal displacement device the demanded knee joint flexion angle, equal to 120° of arc. After 5-minute duration rest and measurement of background data the test subject on a command of aviation physician causes by both legs muscular step-graded increasing pressure on pedal sequentially at 120, 160, 200, 240 and 280 kG-power with maintaining of required static effort for 30 seconds. The test is accomplished up to indicated level or interrupted due to physical exhaustion of testee, related to muscular fatigue or occurrence of some other objective and subjective signs, suggesting, that the test of physical strengthening tolerance determination should be stopped. In process of static loading and after its completion at 1-st, 2-nd and 5-th minute there have been performed electrocardiographic registration and monitoring and blood pressure measurements.

The signs of physical exertion tolerance threshold achievement are following:

- appearance of painful sensations;
- emergence of weakness, dizziness, headache, dyspnoe;
- inability to maintain required level of physical strain;
- electrocardiographic disturbances;
- exceeding the maximal systolic blood pressure beyond 220 mm Hg, and diastolic one beyond 120 mm Hg, or sharp fall of both parameters;
- marked tachycardia — above 85% level accordingly to Shepard's nomogram.

The expert evaluation of statoergometric loading test was performed, taking into consideration the parameters of physical effort culmination and physiological reaction, at 4 point scale:

- excellent (the consummation of full program of sequential efforts — 280 kG-power for 30 s);
- good (not less than 240 kG-power for 15 s);
- satisfactory (more than 160 kG-power for 30 s);
- poor (160 kG-power for 30 s and lower).

In case of physical strengthening threshold tolerance limit attainment the total estimation is decreased by 1 point.

The statoergometric loading test can not be replaced by widely spread and well known veloergometric test. Statoergometric loading test performance as well as action of high $+G_z$ hypergravitational forces provoke similar in its direction and markedness hemodynamic reaction, while use of veloergometric functional loading test reveals qualitative differences in cardio-vascular system response to these effects (Figure 3).

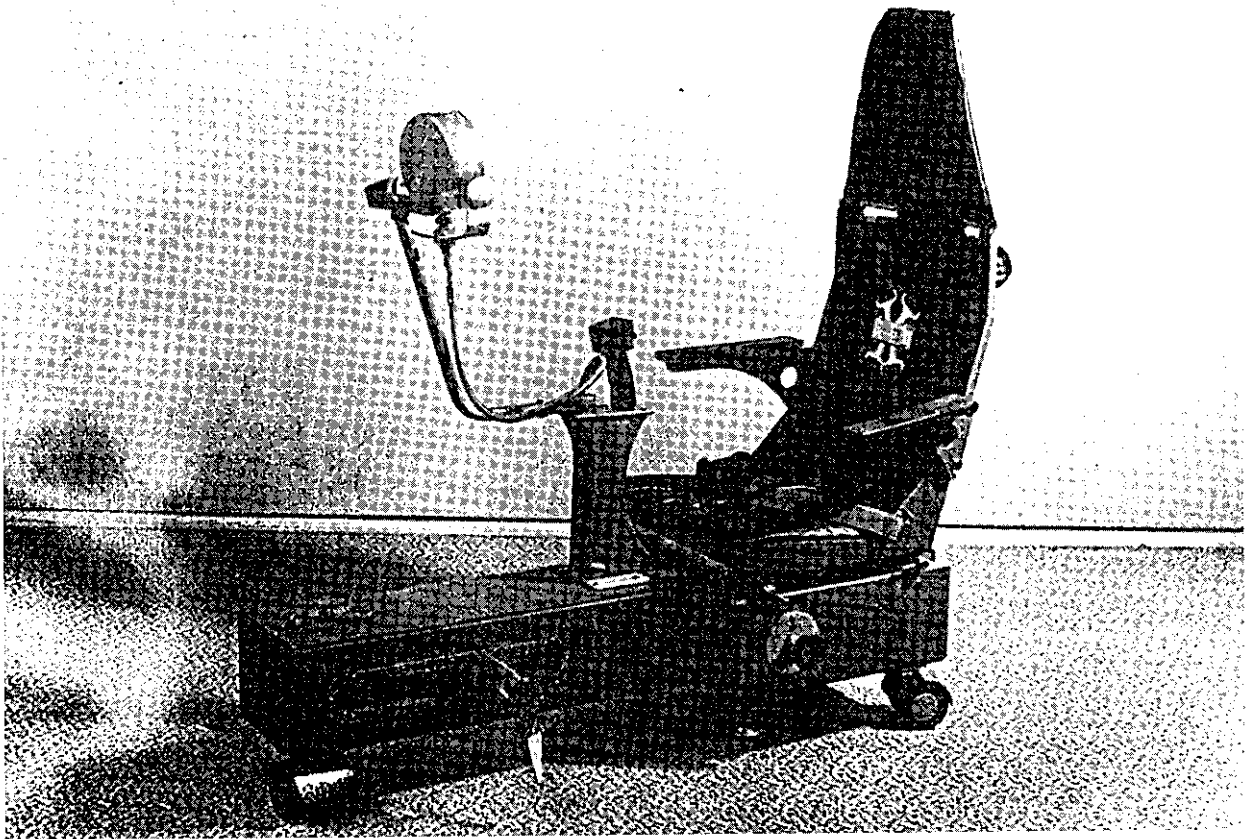

Veloergometric test
 (1100 kGm/min)

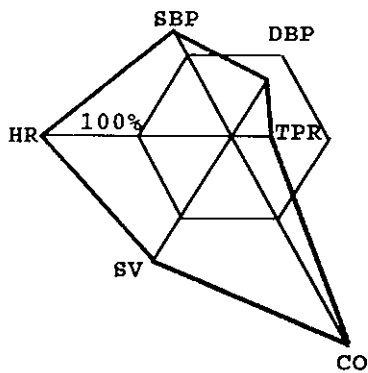

Statoergometric test
 (280 kG power)

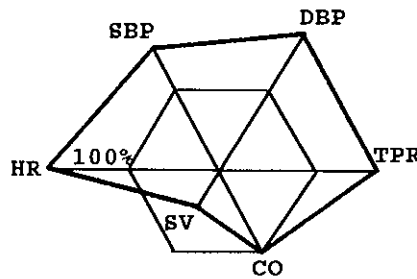

+G_Z Centrifuge test
 (+9 G)

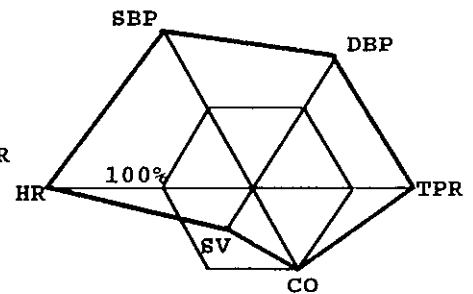

Fig. 3. Comparison of hemodynamic reactions under influence of +G_Z centrifugation, statoergometric and veloergometric functional load tests.

Graphic designations:

HR - heart rate;

DBP - diastolic blood pressure;

CO - cardiac output;

SBP - systolic blood pressure;

TPR - total peripheral resistance;

SV - stroke volume

All data are referred to initial level, which is equal to 100, and expressed in per cents.

The practical importance of statoergometric test is based on strict correlational interaction ($R=0,88$) between maximal static physical performance and single +G_Z centrifugation tolerance at peak values from 4 to 8 G for 30 sec without use of anti-G suit (Figure 4).

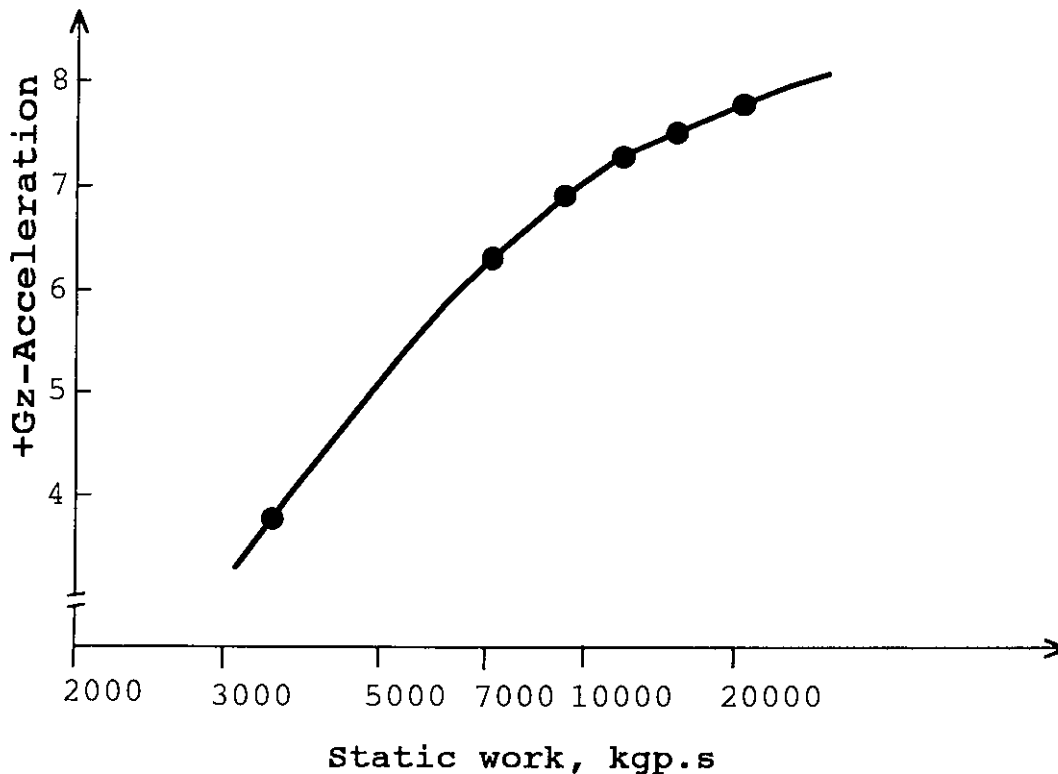

Fig. 4 Correlational interdependence between maximal static physical performance and +G_Z-tolerance.

As maximal static physical performance rises, so rises the limit of maximal endurable $+G_z$ -stress.

The individuals with high static physical performance are capable to withstand the $+G_z$ -accelerations at 8 G for 30 sec without anti-G suit, while persons with low static performance — less than 5 G.

In centrifuge experiments there was proved the possibility of prognostication in flyer staff the complex profile SACM tolerance with peaks up to 9 G for 15 seconds with help of statoergometric loading test accordingly to its estimation criteria.

The final possibility of prognostication of high level $+G_z$ -accelerations' tolerance on a base of statoergometric loading test was certified in special flight experiments with participation of 75 military flyers, who made expert test sorties on-board of MIG-29 fighter-aircraft.

The $+G_z$ -tolerance was estimated on a maximal $+G_z$ -peak, attained by flyer in flight without visual disturbances.

The results of investigations have confirmed sufficiently high correlation in flyers between maximal endurable $+G_z$ -acceleration in flight and statoergometric loading test performance (Figure 5).

The excellent mark of statoergometric test performance with a probability 0,75 corresponds to tolerance of $+G_z$ -accelerations at 8 G and higher, good mark — 7,5—8 G and satisfactory mark — 7 G and lower.

The excellent mark of statoergometric test performance leads to arrive at the conclusion about sufficient physical preparedness of flyer to flights with high $+G_z$ -intensities. The individuals with good and satisfactory mark of statoergometric test performance are recommended before being admitted to flights with high level $+G_z$ -stresses, to pass additional course of special physical training exercises, directed at force and static endurance development for leg and abdominal press muscles.



Fig.5. The dependence of flyer's maximal $+G_z$ - tolerance limit on mark of statoergometric endurance load test.

Evaluation of statoergometric test validity

* - difference is significant in relation to for mark "satisfactory"

** - difference is significant between marks "satisfactory" and "good"

The flyers with lower assessment of their statoergometric loading test tolerance can not be admitted to flights in high performance fighter-aircrafts and are needed in deepened medical examination with subsequent carrying-out of curative-prophylactic and rehabilitational measures.

In estimation of efficiency of performed curative-prophylactic and rehabilitational procedures as well as special physical training one should keep in mind, that augmentation of expert value of test by 1 point approximately corresponds to increase of $+G_z$ -tolerance of flyer by 1 G.

2. Special training of pilots to flights with high sustained $+G_z$

Striving to heighten the flyer's tolerance to high sustained $+G_z$ during transition on extremely maneuverable fighter-aircrafts, the specialists of our Institute have elaborated a complex of technical means and methods of special physiological preparation of flying staff. Such preparation envisions the teaching of flying personnel on special procedures of ground theoretical and simulator training, the course of physical exercises on special simulator gears, the instructive and familiarizing centrifugation and special inflight training during sorties. In process of special preparation there have been carried out the measures in following main directions:

- theoretical education in the field of hypergravitational physiology, elucidating the effects of high-sustained and rapid onset rate $+G_z$ -accelerations on pilot organism and their influence on flying performance;

- learning and training of protective counter-G muscular and breathing maneuvers, the specificities of pilot's behavior and breathing activity under influence of high-sustained and ROR $+G_z$ -accelerations;

- carrying-out of special physical training, directed for augmentation of efficiency of protective anti-G straining maneuvers;

- the instruction of pilot personnel in exploitation of new standard anti-G protective equipment;

- theoretical and practical preparation of pilot personnel to safety measures during action of high-sustained and rapid onset rate $+G_z$ -accelerations (the particularities of self-control for own psychophysiological state, criteria of attainment of dangerous conditions and methods of prevention of such events etc.).

Implementation of developed complex of technical means and procedures of special preparation of young and healthy flyer population with initial lowered $+G_z$ -tolerance allowed to elevate it by 2,5—3,5 G.

Approbation of special training course with participation of flyers' groups, pioneering the high performance fighter-aircrafts MIG-29 and SU-27, has confirmed, that 92% of trainees successfully passed centrifugation tests with $+G_z$ -acceleration peaks up to 9,0 G, with duration intervals at 15 s and onset rate 1 G/s and up to 8,0 G for 15 s time interval with onset rate 4,0 G/s with support of standard anti-G suit.

2.1. Theoretical and simulator preparation

On theoretical lessons the flyers are used to familiarize with specific features of $+G_z$ -acceleration effects, influencing organism and its work performance, under exposure of high-sustained and rapid onset rate $+G_z$ -stress. There has been learned the procedure of AGSM performance, including muscular and breathing protective skills, the construction and rules of exploitation of anti-G equipment.

On practical lessons with flying personnel there have been performed training sessions, aimed at:

- checking of the quality of anti-G suit fitting to pilot's body;

— familiarization of flyer with particularities of breathing under inflation of anti-G suit chambers;

— elaboration of anti-G straining maneuver skills, embracing muscular and breathing methods.

The sessions have been carried out on stand "Statoergometric". The flyer is sitting in chair and has fixed himself with harness restraint system. The sessions are performed at two levels of pressurization of anti-G suit chambers: 0,15 kGp/cm² — in first stage and 0,3 kGp/cm² — in second stage (what approximately corresponds to subjective sensations of pilot in real flights under exposure of +4—6 G_z-accelerations). The duration of each stage is 1 minute. The pressurization is created and dropped for 10—15 seconds. The total time of one training session at each stage is about 1,5 minutes. It is advisable to give the flyer between first and second training stages of pressurization of anti-G suit 5 minute rest.

Under effect of anti-G suit pressurization the pilot works out the skills of positive pressure breathing and procedure of protective physical strengthening of legs and abdominal press muscles. For this goal as the pressure in AGS chambers raises the flyer gains leg pressure effort on pedals and switches the breathing regimen from abdominal type to pectoral one, while simultaneously maintaining the abdominal press muscles in strengthened position (especially at inspiration phase). counter-acting to pressure of AGS abdominal bladder. The breathing pattern should be kept rhythmical, with shortened inspiration phase and delayed expiration with some lesser, than usual for concrete pilot, deepness of pulmonary excursion.

2.2. Special physical trainings

Recently carried-out investigations have shown, that in improvement of flyer's tolerance to high-sustained +G_z-acceleration the great importance has the realization of special physical sessions, aimed at development and formation of such professionally meaningful qualities, as force and static endurance predominantly abdominal press, leg, neck, spinal column muscles. Ability of pilot to perform the protective counter-G maneuvers to some degree depends on the physical preparedness of above cited muscular groups.

For working-out of these physical qualities it is desirable to apply the statodynamic exercises. These exercises should be performed in slowed tempo with involvement of a vast number of muscular groups at short-time Valsalva maneuver and thoracal breathing. Gaining of force and static endurance has been tracked predominantly in such body positions, in which were carried out the training exercises. Therefore for such physical training sessions we have developed special gears, complexes of exercises, which in vast degree consider the working posture of flyer in aircraft cockpit.

In our experiments we have assessed the efficiency of special physical training sessions for uplifting of flyer's +G_z-tolerance. On special trainer the healthy young people, who took part in investigation, have performed the complexes of exercises, which provide the lifting by arms and legs the bar in various working postures (Figure 6). The training weight of loading was about 70—80% from maximal level. Each session included the exercises for physical rehearsal of 2—3 muscular groups. There were performed 3 approaches. The trainees performed maximal endurable number of movements in slowed tempo without tugs and jerks. The rest interval between approaches was about 1,5—2 minutes. The sessions were held two times per week for 2,5 months.

After the ending of physical training program there was registered marked hoist of special physical qualities. The static endurance of leg, spinal column and abdominal press muscles has risen in average by 125,43 and 36% correspondingly.

In general, the whole course of such physical rehearsals has boosted the +G_z-tolerance by 0,5—1,0 G, mainly in individuals with lower initial level. However, in indi-

viduals with high initial $+G_z$ -tolerance level ($+6 G_z$ — for 15 seconds without anti-G suit) there was not registered the further improvement in $+G_z$ -tolerance.

Lately, the scientists and research workers of our Institute have carried out the investigations, dedicated to study the efficiency of isometric training exercises on static endurance of flyers with support of stand "Statoergometric". The training cycles were carried out 2 times in a week for 1 month. As the training loading was used the load about 75% from maximal performed static work capacity according to data of statoergometric test.

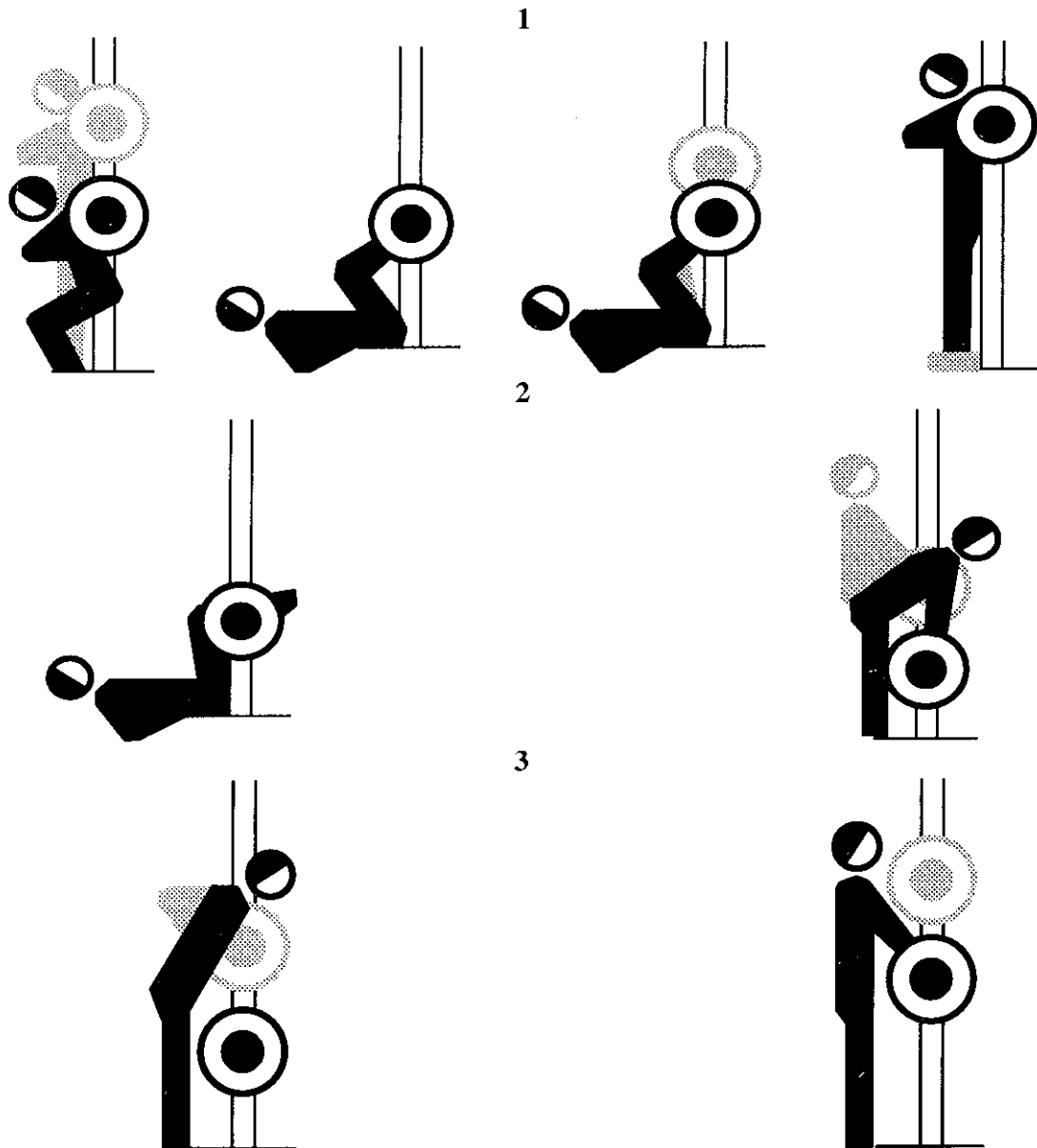

Fig. 6. Complex of special physical exercises with bar:

- 1. For leg muscles;**
- 2. For abdominal press and spine;**
- 3. For arm muscles.**

Before to start training session the flyer fixed himself by restrained system. In process of loading rehearsal he has generated by legs the stepped increasing push efforts on pedals at values 120, 160, 200 and 240 kGp with maintaining of each required exertion for 30 s. Additionally between serial approaches to fulfill the statoergometric loading exer-

tion maintaining there were carries out the training exercises for neck muscles with help of special neck loading appliance (Figure 7).

In investigations took part 26 military flyers, aged 25—39 years, which have demonstrated the satisfactory endurance of statoergometric loading test.

As a result of 8 sequential rehearsals the static endurance of abdominal press and leg muscles rose in average by 28,2% ($p < 0,001$), while the markedness of physiological reactions to static loading fell.

In total, the implementation of special physical training course with help at "Statoergometer" allows to raise the $+G_z$ -tolerance in average by 1,0 G.

The data, received in experimental investigations, have suggested the good efficiency of special training equipment, enabling for short-time periods to fulfill the complex training exercises of main muscle groups, which determine the flyer's tolerance to unfavorable effects of high-sustained $+G_z$ -accelerations.

It is necessary to accentuate, that physical rehearsal of force qualities should mandatory to be done in combination with means of general physical preparation: calisthenics, sport games, gymnastics, swimming etc. The complexing of various physical exercises on training session makes possible to solve in most efficient manner not only the tasks of special physical preparation, but to maintain the general physical condition of flying personnel at high level.

2.3. Centrifuge training

The most efficient method of preparation to flights with high-sustained $+G_z$ -accelerations is undoubtedly the centrifuge training run of flyers.

In accordance with procedure, developed by us, the centrifuge training of pilot personnel has been conducted for three working days. During centrifugation the flyers are subjected to sequential exposure of 3 cycles of G_z -accelerations profiles, with peaks of $+G_z$, varying from 2 to 9 G, and duration interval at each level for 15 seconds (Figure 8). It must be stressed, that flyers in centrifugation use the standard anti-G protective equipment.

At first day of centrifuge training the maximal peak of $+G_z$ -stress should not exceed 7 G; at second day it is raised up to 9 G with onset rate 1,0 G/s. At third day the centrifugation is performed with onset rate at 4,0 G/s and maximal peak of $+G_z$ -stress at 8—9 G in dependence on used anti-G suit.

Above mentioned scheme of centrifuge training takes into account the main characteristics of simulated aerial combat maneuvering (peak, onset rate, time of exposure at achieved plateau and repeatedness of action) influencing on pilot in flight on-board of high performance fighter-aircraft. Incidentally the used principle of stepped increment of $+G_z$ -accelerations considers the specific traits of flyer's organism adaptational reactions under effect of hypergravitation, what significantly raises the safety of carried-out centrifuge trainings. And this circumstance to some extent confirms the absence of GLOC events during centrifugation runs of flying personnel.

In a whole, the received data have suggested, that centrifuge training, as it is performed, allows to increase the individual $+G_z$ -tolerance of flyers by 1,5—2,5 G.



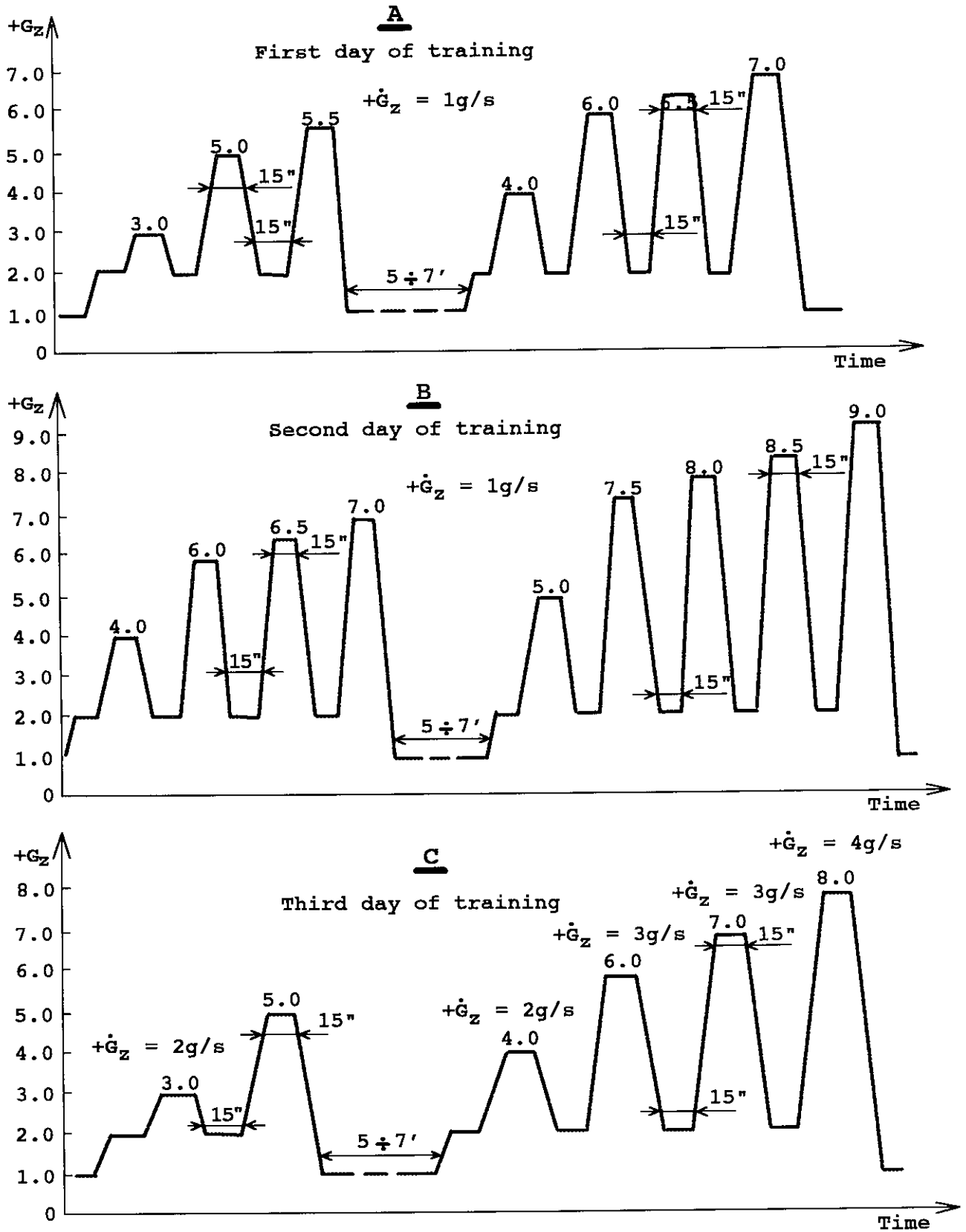

Fig. 8. Characteristics of +Gz-acceleration centrifuge training profiles.

2.4. Special inflight training of flyers in the sorties

The systemic flights with stunt and acrobatic maneuvering are a very effective way to lift the $+G_z$ -tolerance in flying personnel. In this connection it is necessary to provide the training sorties for pilots on a base of special flying complexes and aerial combat drills. These complexes enable from the physiological standpoint, with consideration of dynamic individual progress to master in a most safe way with high-sustained $+G_z$ -levels as well as to maintain and conserve the attained level of combat readiness and proficiency and to restore the required level of $+G_z$ -tolerance after prolonged suspension or abstentions from flying duties. Practical realization of such approaches must be based on consideration of relationships of flyer's adaptational reactions to repeated and chronic exposure of hypergravitational loads during flight, several sorties in flying day for week, month etc. Certainly, these specific features must be analyzed in context of flyer's professional activity, caused by performance of highly intensive $+G_z$ -maneuvering evolutions. Proceeding from such notions, we believe ourselves to be in the right to substantiate as reasonable the adherence to the following principles in process of special inflight training of pilot personnel during flights with intense and energetic maneuvering.

As it is well known, the flyer's control activity under influence of $+G_z$ -accelerations is shared multi-task performance. So at initial phase of flight training it is commendable to perform the aerobatics maneuvering sub-tasks with $+G_z$ -accelerations up to 6—7 G with duration of peak up to 15 s. The main goals of flight training in pilot personnel are to elaborate the solid flight skills in such bizarre conditions, as well as to acquire and master protective muscular and breathing counter-G maneuvers, the ability to control its own psychophysiological state.

After fulfillment of first stage of flight training the pilots are making a start to formation of flying skills under exposure of high-sustained $+G_z$ -accelerations with peaks more than +7 G and duration for 15 s. For solution of that task it is necessary to perform the systemic flying missions with sophisticated stunt flights. The rest intervals between two consecutive flight training missions should be not less than 2 days, in order to guarantee the complete restoration of physiological functions, and not more, than 10 days, in order to prevent the loss of training effect. The total number of flight missions, the admissible maximal peak of $+G_z$ -acceleration must be determined, taking into consideration the individual level of pilot's flying proficiency and his flying log-book.

It is desirable to plan for one flying day only 2 flight missions with intense $+G_z$ -maneuvers. In accomplishment of such missions the maximal $+G_z$ -tolerance and proficiency of flyer has been registered at second flight. Therefore, for the first flight it is commendable to perform the aerial combat maneuvers with $+G_z$ -peaks up to 7 G, and for the second flight mission with $+G_z$ -peaks more than 7 G. It was shown in our previous investigations, that initial compensatory-adaptive reactions of human pilot are revealed at 5—7-th seconds of repeated exposure of $+G_z$ -accelerations, but their maximal expressiveness occurs in 1—1,5 minutes. Hence, for mobilization of physiological compensatory mechanisms of organism and enhancement of its flying efficiency the flyer must perform at the beginning of acrobatic complex 1—2 maneuvers with $+G_z$ -peak accelerations at 4—5 G, and after that to make piloted evolutions with higher levels of $+G_z$ -accelerations. The gradual and smooth increase of $+G_z$ -acceleration enables to pilot more reliable and safer to control his psychophysiological state, because interval between occurrence of visual disturbances and $+G_z$ -loss of consciousness, as a rule, is more than 1,0 G.

For conservation and maintaining of achieved $+G_z$ -level acceleration tolerance it is necessary to perform not less than 4 sorties per month with total duration of aerial combat maneuvering activity up to 5 minutes with flight-free rest periods for 7—9 days. It should be stressed, that 3 sorties are performed with maximal $+G_z$ -acceleration peak at 7,0 G and duration for 15 s, and one sortie — with 9,0 G of same duration.

In case of temporary grounding or suspension from flying activity, lasting for 2—5 weeks, the $+G_z$ -acceleration tolerance level is decreased by 0,5—1,5 G. The initial level of psychophysiological tolerance and progress has been restoring for 2—4 flying days. This circumstance should be constantly kept in mind at planning of flight missions with high level $+G_z$ -acceleration for flyers, who were forced to be abstinent from their regular flying duties.

To maintain the required level of flyers' combat readiness and preparedness to flight with high-sustained $+G_z$ -profiles the major importance has also systemic carrying-out of special physical training exercises.

In turn, in case of abundant and excessive exposures to intense and frequent high $+G_z$ -accelerations there is possible not only the lowering of training effect, but appearance of cumulative effects in form of astheno-neurotic syndrome and decrease of $+G_z$ -acceleration tolerance. In order to minimize the probability and risk of cumulative effects of repeated action of high $+G_z$ -acceleration profile it is recommendable to perform not more often, than 2 sorties per flying day at 2 flying days per week.

The homeland experience of flight mission planning of high level $+G_z$ -acceleration sorties on high performance fighter-aircrafts has suggested, that for well trained combat pilots it is sufficiently to provide not more than 2 sorties with high $+G_z$ -maneuvering and maximal $+G_z$ -peaks up to 8—9 G for 15—20 s per one flying day. The rest intervals between 2 sorties must be not less than 60 minutes with consequent release from flying duties for period not less than 2 days. In some cases there may be required the realization of complex of restorative-rehabilitational measures under supervision of senior aviation physician.

For this reason only complex and correct administration of various counter-G means and procedures may warrant efficient protection of flyer from high-sustained $+G_z$ -levels in flight on-board of modern fighter-aircrafts.

Implementation in practice of developed in process of long-standing investigations complex of appliances and methods of selection and special training of flyers, directed to lift the high-sustained and steep onset rate $+G_z$ -acceleration tolerance, will conduce to more efficient use of maneuvering potentials in new generation fighter-aircrafts, augmentation of flyer's efficiency and ensurance of flying safety.



ANTI-G SUITS

Clère J.M., Ossard G., Kerguélen M.

Aerospace Medical Laboratory
 Flight Test Center
 F-91228 Brétigny-sur-Orge Cedex
 France

1. INTRODUCTION

The relaxed Rapid Onset Rate (1/Gs) G-level tolerance of an individual seated upright (primarily +G_z exposure) is about 4 G (Cochran et coll., 1954). Since pilots are expected to fly high performance aircraft with 9 +G_z capability, G tolerances must be increased by approximately 5 G. This increase is accomplished using the anti-G suit that accounts for about 1 G increase and the anti-G straining maneuver (AGSM) that increase G tolerance by 4 G. These operational methods to increase G tolerance are standard throughout the world, although some differences in the manner in which the AGSM is performed have been reported for the USSR and China.

The concept of preventing acceleration intolerance symptoms by an artificial system was recommended after World War I (WW-I). The first idea, in France, seems to be a kind of elastic band wrapped around the legs (a kind of support stocking). In 1932, in USA, the concept of the first "anti-G suit" was developed by Dr. Cecil Drinker, Harvard School of Public Health and Lt Cdr John Poppen, US Navy Bureau of Aeronautics. It was an inflatable abdominal belt which was tested on dogs and finally on humans. However, the G protection provided was poor, so research was discontinued (Poppen et Drinker, 1951). First real anti-G suits and their use as an artificial system for enhancing protection against G were made during WW-II.

In Australia, Cotton developed a non-stitched fabric pneumatic suit that increased G tolerance by about 30% (Brook, 1990). The "Cotton" suit was flown by American fighter pilots in the

Pacific and Europe. In Canada, Frank invented an anti-G suit that was filled with water offering an increase of 1 G and which saw limited combat in Europe. Several types of anti-G suits were developed in the world, but the 5 bladder inflated anti-G suit, prevailed and is the forerunner of the current operational anti-G suit. This early anti-G suit was developed by David M. Clark (manufacturer of cloth and underclothing) in close association with Drs. E.J. Baldes and Earl Wood of the Mayo Clinic Acceleration Research Group.

For a number of years, no major development of anti-G suits appeared in operational use. Several reasons explain this fact. The first is linked to the absence of any real necessity for such development. Life support systems are relatively inexpensive, but the increased capabilities they provide are difficult to quantify. This problem was exacerbated by the common feeling among crewmembers that "only the weak guys have a problem with G" (Hill, 1995). Life support systems by their very nature can encumber the crew member, penalize comfort, and take time to don. Pilots like flying their aircraft with minimal equipment. Already, when the first anti-G suits appeared as an operational system, they were only used by a few test pilots.

During the 80', several mishaps induced by G loss of consciousness (G-LOC) obliged us to reconsider anti-G protection (Pluta, 1984). So, centrifuge training was one of these new methods enabling to reduce the risk of G-LOC. If pilots, in good health, are well trained on a centrifuge, they are able to sustain a 9 +G_z run with no G-LOC. The necessity of improving anti-G suits is linked to the repetition of

acceleration periods during a dog-fight, which induces fatigue and reduces pilots ability to sustain high levels of acceleration several times. Furthermore, the goal of a new anti-G suits is also to improve combat effectiveness. So, improvements of anti-G suits stem from new concepts or from old concepts but using new technologies. This chapter is divided into several sub-chapters: description of anti-G suits, physiological effects and the different improvements made by several Air Forces.

2. DESCRIPTION OF AN ANTI-G SUIT

The different anti-G suits, such as the CSU-13B/P in US or the ARZ 817 and 820 in France, are typically standard anti-G suits. Current operational suits have a 5 bladder system and cut-away style. They have several goals. The main one is to protect pilots against G-load but they have, in fact, other benefits: they protect pilots in case of fire, they can be used to carry maps or other flight tools. Most of the time, they are worn over the flight suit. They are available in several sizes (4 to 6) for different male statures (female combat-pilots are emerging in certain NATO Air Forces). The suit is zipped onto the the body and with lacing or strapping, which allows for minor body adjustment, that can be accomodated with only 4 to 6 different sizes. The suit must fit snugly to the body so that the maximum benefit is obtained from pressurization of the bladders.

Anti-G suits are the essential part of a system which constitutes the anti-G system. This anti-G system comprises a gas supply, which is usually a gas compressed by the jet engine. This gas is filtered and supplied at a normalized pressure (200 to 1500 kPa or 29 to 220 psi). An anti-G valve which is set on the seat or in the cockpit delivers the pressure in the anti-G suit, via a hose. Specified air pressure as provided by this valve will not operate in G fields less than 2 +G_Z - so it is not activated during aircraft buffeting and moderate turns. However, at 2 +G_Z, in most NATO Air Forces, air pressure is provided at 7 to 10.4 kPa (1 to 1.5 psi) per G, depending on its type, to a maximum of approximately 70 kPa (10 psi). For different aircraft, in France, the anti-G suit gas is the same oxygen supplied for breathing and the

pressure schedule is always at 7 kPa per G (1 psi/G) to a maximum of 55 kPa. These schedules and specifications are normalized by the STANAG 3 200.

3. PHYSIOLOGICAL EFFECTS OF ANTI-G SUITS

Anti-G suits have several effects. The principle goal of anti-G suits is to increase arterial resistance by compressing the main arteries of the lower body (Wood et Lambert, 1952). This explains why the first anti-G systems were developed with cuffs set at the beginnings of the limbs. So, arterial pressure is increased as well as the relaxed G-level tolerance. At 4 +G_Z, this increase is approximately 15 mmHg that occurs because of a similar relative increase in vascular resistance. This increase in arterial pressure accounts for about 0.7 G increase in G tolerance or 50% of the increased G value of the suit. The other half increase in G tolerance comes from the reduction of the eye-heart vertical distance of 3 cm - raising the heart and diaphragm with the inflation of the abdominal bladder. This reduction of 3 cm at 5 +G_Z has the same effect as increasing the arterial pressure by approximately 11 mmHg or about 0.5 G (Burton, 1988; Rushmer, 1947). The least effective cardiovascular support provided by this anti-G suit is in the cardiac output and stroke index parameters that show where improvements can be made in the design of this suit to provide better support for venous return.

The relative contribution of the various elements of the pneumatic G-suit in enhancing G-tolerance has been determined (Burton et coll., 1974). As noted in the previous paragraph, the majority of increase in relaxed G-level tolerance comes from the abdominal bladder. Pressurization of legs accounts for only 0.2 G- this tolerance increase is in addition to the increased tolerance contribution of the abdominal bladder. A properly fitting anti-G suit without pressurization will increase relaxed G-level tolerance by 0.3 G that in addition to the increase in G-level tolerance from inflating the suit (Burton et Krutz, 1975). The approximate 1-1.5 G protection provided by the anti-G suit is independent of (additional to) the 1 G protection

from the baroreceptor response (GOR tolerance).

The effect of the operational anti-G suit on fluid shifts below the heart in the abdominal, thigh, and calf regions of a subject during a gradual onset rate (GOR : 0.1 G/s) to $5 +G_z$ without the suit and $7 +G_z$ with the suit has been studied. Without the suit, an increase in fluid volume of nearly 10% occurs below the heart, whereas, with anti-G support this fluid shift is reversed with a net reduction in fluid shift at $7 +G_z$ over $1 +G_z$ controls. Some shift in fluid below the heart begins immediately with the onset of G even with the anti-G suit that, of course, has not begun to inflate until $2 +G_z$. However, before $3 +G_z$ is reached, the anti-G suit begins to reverse the shift of fluid below the heart.

Even in these action modes, anti-G suits protect poorly (1.5 G) in comparison with more physiological methods such as a tank in which subjects were totally immersed and which permitted them to sustain 31 G (Gray et Webb, 1960). This is why several projects were pursued after WW-II in order to improve the efficiency of the anti-G suit ensemble.

4. EVOLUTION OF THE ANTI-G SUIT SYSTEM

The anti-G suit system, which comprises an anti-G suit, an anti-G valve and a gas supply has been improved at different levels : the anti-G suit it-self, the schedule of inflation, and the response time of the anti-G system.

4.1. Evolution of anti-G suits

For operational reasons and particularly for easy use, the 5 baldder anti-G suit has been used since WW-II. In fact, for a pilot flying a fighter with a standard reclined seat (between 10 to 20° back angle), the concept of an uniform pressurized anti-G suit is in contradiction with the physiologic basis (Burton, 1988). The hydrostatic pressure on the lower part of the body (feet and legs) is higher than on the thighs abdomen. This is why the idea of a system with uniform pressure and gradient pressure concept was incorporated in the pneumatic level anti-G suit and developed at USAF-SAM. This suit,

designated as the UP (uniform pressure) anti-G suit was evaluated using an Aerial combat maneuver (ACM) acceleration program (Shaffstall et Burton, 1980)

The uniform pressure suit utilized a pneumatic lever to apply pressure to legs, and a restricted abdominal bladder to apply pressure to the trunk area. The pneumatic levers were individually sized for each subject in order to transfer pressure to the calf region using a 4 :1 capstan - to leg-pressure ratio and a 5 :1 capstan to leg pressure ratio for the knee and thigh. Two valves were set to start suit pressure pressurization at $+2 G_z$; hence, suit pressurisation was expressed as $\text{psi} \times (G-2)$. One valve pressurized the abdominal part and the second the leg capstan system.

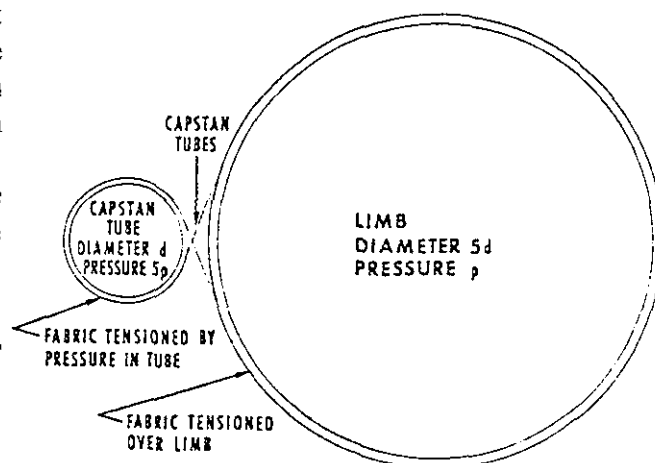

The principle of capstan anti-G suit (from Shaffstall et coll., 1980)

The evaluation of this anti-G suit demonstrated that, during a $4.5 - 7 +G_z$, 10 s, ACM profile, G-time tolerance was 497.0 ± 112 s with the following pressurization : abdominal bladder schedule : 83 hPa/(G-2) (1.5 psi/G-2), pneumatic lever schedule 517 hPa/(G-2) (7.5 psi/G-2). This tolerance was higher than the tolerance obtained with the standard USAF CSU 13/P anti-G suit, which was pressurized at the same schedule as the UP abdominal bladder. For this last anti-G suit, the time tolerance was only 213 ± 41 s. To explain this better performance, the study suggested an increased venous return. It also suggests that abdominal bladder support during high $+G_z$ accelerations is less important than adequate leg pressure.

These findings correspond to those of Burton and Krutz (1975) --namely, that the abdominal bladder is more important during accelerations when the subject is relaxed, and leg pressurization is the dominant factor during high +Gz accelerations which require straining. In order to obtain a better venous return, efforts have been made with other concepts : extended or full coverage anti-G suit. These concepts were recommended because the initial UP suit was bulky, hot, and slow to inflate using standard anti-G valves.

Several models of extended or very extended bladders suits were developed in US : the TLSS (Tactical life Support system) anti-G suit, the Navy EAGLE (Enhanced Anti-G Lower Ensemble) anti-G suit (Burns et Hill, 1994). In Europe, several models were also produced by different countries for their own new fighters : ARZ-830 anti-G suit for the Rafale program (Clère et coll., 1993) ; different extended anti-G bladders concepts was studied for EFA (Green, 1992).

The concept of extending coverage is linked to the utilisation of Positive Pressure breathing during G (PBG). Although this method increases G-time tolerance by reducing fatigue induced by AGSM, it has also a potential inverse effect which is to create chest pressure which is above normal pressure and potentially reduces venous return. This is why extended bladder anti-G suits enabling better venous return were developed.

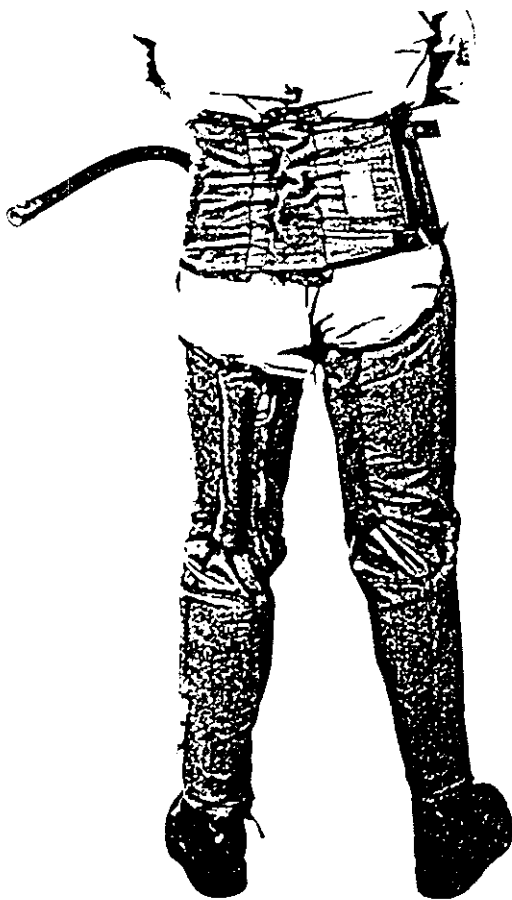

Front view of the Aerazur 830 anti-G suit



Rear view of the Aerazur 830 anti-G suit

Green (1992) reported the tolerance obtained with different brands of anti-G trousers : Standard UK Mk-4 suit, Extended Mk-4 suit, Intermediate FAGT (full cover anti-G trousers), crotchless FAGT and full FAGT

Relaxed G-level tolerance was estimated by a series of centrifuge runs of 15 s duration at peak G for each protective condition. The acceleration level of the next run was determined by the subject's visual response to

his previous run until the endpoint was achieved. In all cases, the G onset rate was 1 G/s. In this study, it was demonstrated that the crotchless anti-G trouser improves by 1.1 G the level of tolerance compared to the standard Mk-4 suit. Moreover, Extended coverage anti-G trousers have not significantly increased G tolerance.

Similar results were obtained in the study carried out in the Aerospace Medical Laboratory, in France (Kerguelen et coll., 1995). An ARZ-830 anti-G suit was evaluated by a similar protocol. This suit has 30% more bladder surface than the standard anti-G suit (ARZ 820). It was compared to the ARZ-AGSS of which the bladders have 50% more surface than the ARZ-830 and to a reference condition (no anti-G suit and relaxed). Under these experimental conditions, a gain of 2.1 G was observed with these two anti-G suit without statistically difference between them.

Nevertheless, if the comparison had been made with PBG (18 hPa/G 4 to 9 G), and with a 5-9 +G_z, 10 s SACM profiles, it would have concluded differently. It was observed during a first trial with an anti-G ensemble (VHA 90 counter pressure vest and a standard ARZ-820 anti-G suit (70 hPa/G-2)) that the G-time tolerance was approximately 3 minutes. In a second trial, with a similar protocol, it was observed that G-time tolerance was 5 minutes if ARZ-820 was changed to ARZ-830 (Ossard, Morgan et coll., 1994). This comparison is controversial because the population of subjects is not the same. Other arguments can be presented with other experiments which were carried out with full coverage anti-G suits.

Full coverage anti-G suits were developed to give better G level and time tolerance.

The anti-G suit which was developed by the Swedish for their Grippen aircraft program is a full coverage anti-G suit. It has the particularity of being worn below the flight suit and not over it (Balldin et coll., 1989). A 0.5 G level tolerance increase was observed if compared to a normal anti-G suit during a GOR (0.15 G/s). The schedule of PBG was 18 hPa/G, 4 to 9 +G_z and the anti-G suit schedule was 100 hPa/(G-2) (1.5 psi/(G-2)).

The ATAGS (Advanced Technology anti-G suit) was the latest modified version of the uniformed pressure suit. Compared to the CSU 13 B/P suit, it has an improved (internally restrained) abdominal bladder and provides complete bladder coverage of the legs, and also feet, by means of optional pressure socks.

With a 5-9 +G_z, 10 s SACM profiles, the G time tolerance was compared between ATAGS and CSU 13 B/P suit. It was demonstrated that with a schedule pressure of 103 hPa/(G-2) (1.5 psi/(G-2)), G time tolerance was 164 ± 38 s with ATAGS and only 80 ± 15 s with CSU 13 B/P inflated at the same pressure schedule (Fisher et coll., 1991).

In order to explain the improvement of G tolerance time, it was argued that a reduction of fatigue and an increase of venous return occurred with AGSM, when subjects wore an extended or a full coverage anti-G suit (Kruz et coll., 1990).

During the experiments presented above, several subjects sometimes found discomfort induced by the enhancement of the surfaces of the bladders and a certain difficulty of mobility or an heat stress (Lejeune et Loncle, 1993). In certain cases, this was not true and pilots rated ATAGS overall comfort as equivalent to standard anti-G suits (CSU 13 B/P) (Morgan et coll., 1993). But, it was sought a pressure schedule enabling an equivalent protection without this discomfort. These schedules are often lower than the standard schedules as it is presented in the following chapter.

4.2 Pressure Schedules of the anti-G pants

Since the fifties, in France, the pressure schedules of anti-G suits have been lower below (70 hPa/(G-2) or 1 psi/(G-2)) than the schedules currently used in the other NATO Air Forces which are often 100 hPa/(G-2) or 1.5 psi/(G-2)). After questioning several recently retired engineers and test pilots, it was assumed that, during this period, test pilots had the choice between the two schedules and most of the time they chose the low schedules giving them better comfort. After that, for reasons of simplicity, only the low schedule was set in the anti-G valves.

This subjective appreciation made us concerned. With the Rafale aircraft program, it was decided to study the potential interest of a 100 hPa/(G-2) or 1.5 psi/(G-2)) for improving G level tolerance compared to 70 hPa/(G-2) (Ossard, Clère et coll., 1993 et 1994). This study was carried out in the human centrifuge of the Aerospace Medical laboratory with a series of 10 s runs incremented by one G until G level tolerance limit (50% peripheral light loss, PLL) was reached. The G onset rate was 0.8 G/s. No statistical difference of G-level tolerance nor blood velocity difference measured by transcranial Doppler were found. Moreover, subjects found the highest pressure schedule uncomfortable.

Several authors, in the world, have performed similar research concerning a lower pressure schedule.

Meeker (1991) demonstrated that for a 5-9 +G_Z, 10 s SACM, the G time tolerance was not statistically different between an anti-G suit pressure schedule of 100 and 78 hPa/(G-2) (1.5 to 1.14 psi/(G-2)). It was recommended to use the lower schedule for the future. On the other hand, a lower pressure schedule (57 hPa/(G-2) or 0.83 psi/(G-2)) was insufficient.

In another similar experiment with PBG, uneven results were observed (Krock et coll., 1994). This experiment compared with extended coverage anti-G trousers different pressure schedules 55, 76, 103 hPa/(G-2) (0.8, 1.1, 1.5 psi/(G-2)). It was observed that the G level tolerance during a GOR (0.1 G/s) with the lowest pressure schedule was significantly different (84 s) from the other schedules (95, 94 s). During SACM, the statistical difference of G tolerance time was between the two lowest pressure schedules and the highest. The G level tolerances are 147 ± 46, 164 ± 31 and 232 ± 85 s from the lowest to the highest pressure schedules. It seems in this experiment, that the highest pressure schedule gives the best SACM tolerance. This difference is probably induced by the anti-G trouser and by the presence of PBG.

In a final experiment carried out at the Armstrong Laboratory with French equipment (a very extended coverage anti-G suit with

pressurized socks) and with PBG, it was demonstrated during a similar SACM profile that low pressure schedules inflating anti-G pants permit a long time tolerance. The anti-G suit had two different compartments (abdominal and legs) inflated respectively at a schedule of 62 and 56 hPa/(G-2). No statistical difference was observed between the tolerance obtained with this equipment and the ATAGS equipment using also a system of PBG. The time tolerance was approximately 5 mn (Ossard, Bellet et coll., 1994).

To conclude this chapter, we need to get obtain more results to validate an equal G tolerance with a pressure schedule around 70 hPa/(G-2) and 100 hPa/(G-2). It is normal that the lowest pressure schedule gives the least discomfort.

4.3 Response time of the anti-G valve ensemble

As the gas is supplied by the jet engine, all the gas circuits must be designed to give sufficient flow. In the past, with standard anti-G valves, a delay (approximately 2.5 s) was observed between the plateau of acceleration and the plateau of pressure in the anti-G suit. It was acceptable during the seventies, because the G onset rate of the jets was low. With the new generation aircraft, this delay have been considered as questionable. New electronic or pneumatic anti-G valves were developed for reducing this delay. Even, with a solenoid set on a pneumatic anti-G valve, it was possible to anticipate the inflation of the anti-G suit of several 100 ms. It was necessary to make sure that a reduction of the delay or even an anticipation, permitting a reduction of this delay, had an interest in terms of protection.

A study made by Burton (1988) demonstrated that a maximal 2 s delay was acceptable for G-tolerance when G onset rate was 6 G/s. It was demonstrated in this work that reducing delay, did not give a G protection advantage.

Cammarota J. (1978) found that the ALAR high-flow G-valve, a rapid response valve, and a servo valve programmed to anticipate the onset of G by 500 ms, all offered similar protection for G tolerance in ROR profiles, and duration

tolerance in SACM tests, but these were greater than the protection offered by standard ALAR G-valve.

In another experiment (Lejeune et coll., 1991), it was also demonstrated that it was no statistical difference of tolerance between situation with a 2 s delay and 2 s anticipation when G onset rate was 1 G/s.

In a final experiment, with PBG, it was demonstrated that the reduction of the delay even anticipation of inflation of the anti-G suit is very questionable. This experiment was carried out with G onset rate of 4 G/s and 9 +G_Z, 20 s plateaus. A pneumatic anti-G valve, set with a solenoid, controlled by a computer was enable to anticipate the level of pressure at the plateau of acceleration (and not the inflation before the onset of the G). Intolerance symptoms (G-LOC) were observed for several subjects who had physical endurance training. Less intolerance symptoms were observed without anticipation. It seems, for these subjects, that the very rapid inflation induced a parasympathic reflex. Indeed, the heart rate of these subjects was lower at the beginning of the 9 +G_Z plateau than at the rest period before the run (Clère, 1993).

5. CONCLUSIONS

Several improvements were carried out on the anti-G suits and on the anti-G valves. These improvements should enhance G tolerance and pilot effectiveness under G. Most of these improvements need to be applied in operational use and not be simply reserved for the research world. In order to achieve this, these new anti-G equipments must be the least cumbersome and intensive for pilots and efforts must be made to ensure their acceptability.

6. REFERENCES

Balldin U.I., Dahlbäck G., Larson L.E. Full coverage anti-G suit and balanced pressure breathing. FOA Rpt. n° c 50065-5.1, Feb. 1989.

Brook W.H. The development of the Australian anti-G suit. *Aviat. Space Environ. Med.*, 1990, 61 : 176-82.

Burns J.W., Hill R.C. Comparative Centrifuge Evaluation of the Air Force Advanced Technology Anti-G Suit (ATAGS) and the Navy Enhanced Anti-G Lower Ensemble (EAGLE). *SAFE J.*, 1994, 24 (1) : 31-5.

Burton R.R. A conceptual model for predicting pilot group G tolerance for tactical fighter aircraft. *Aviat. Space Environ. Med.*, 1980, 51 : 122-7.

Burton R.R. Physiologic bases of G-protection methods. *SAFE J.*, 1988, 18 (4) : 20-4.

Burton R.R. Anti-G suit inflation requirements. *Aviat. Space Environ. Med.*, 1988, 59 : 601-5.

Burton R.R., Leverett S.D., Michaelson E.D. Man at high sustained +G_Z acceleration: a review. *Aerospace Med.*, 1974, 45 : 1115-36.

Burton R.R., Krutz R.W. G-tolerance and protection associated with different anti-G concepts. *Aviat. Space Environ. Med.*, 1975, 46 : 119-24.

Clark D.M. Anti-blackout suit development. Bureau of Aeronautics report, Contract Noa (s) 8528, June 28, 1946.

Cammarota J. The effect of AGS inflation speed on tolerance. *Aviat. Space Environ. Med.*, 1978, 58 : 505.

Clère J.M. Effets physiologiques de la ventilation en pression positive sous accélération +G_Z. Thèse en Sciences, Paris XI, Orsay, 5 Jan. 1994.

Clère J.M., Burns J.W. Assisted positive pressure breathing: Effects on +G_Z human tolerance in centrifuge. *AGARD-AMP*, 1991? CP 516: 22.1-22.8.

Clère J.M., Cazenave J.M., Canini F., Poirier J.L., Lascourrèges P. Etude de la protection anti-G apportée par le gonflement anticipé du pantalon anti-G et de la ventilation en pression positive. *CRE n° 1187/CEV/LAMAS/DR*, 1993.

Clère J. M., Ossard G., Amichaud J.C., Turillon A., Kerguelen M., Marotte H. Evolution des pantalons anti-G français durant la dernière décennie. *Méd. Aéro. Spat.* 1993, 32 (125): 49-55.

- Cochran L.B., Gard P.W., Norsworthy M.E. Variations in human G-tolerance to positive acceleration. USN SAM/NASA/NM 001-059.020.10, Pensacola, FL, 31 August 1954.
- Fisher J.R., Solana K.E., Meeker L.J. Performance of Advanced Technology anti-G suit (ATAGS) during 5.0-9.0 +G_z simulated aerial combat maneuver (SACM). Proceedings of the 29th Annual SAFE Symposium, 11-13 Nov. 1991 : 268-71.
- Frank W.R., Stewart W.K. Test flights with hydrostatic suit. Canadian Royal Air Force 1939-1943. FPRC301.
- Gray R.F., Webb M.G. High G protection. US NADC, AML. Rpt n° NADC-MA-5910, Feb. 1960 (cited in AGARDograph n° 48, 1961).
- Green N.D.C. An assessment of the +G_z protection afforded by different coverage anti-G trousers. RAF-IAM Rpt. n° 724, 1992.
- Hill R.C. Recent advances in high sustained G protection. SAFE J., 1995, 25 (1) : 78-81.
- Kerguélen M., Ossard G., Clère J.M. Influence de la surface de recouvrement des pantalons anti-G sur la tolérance aux accélérations +G_z et la réponse cardio-vasculaire. CRE n° CEV/SE/LAMAS, 1995.
- Krock L.P., Russel R.L., Siegborn J., Balldin U.I. Reduced pressure in extended coverage anti-G trousers with assisted positive pressure breathing. Aviat. Space Environ. Med., 1994, 65 : 287-92.
- Krutz R.W., Burton R.R. The effect of uniform lower body pressurisation on +G_z tolerance and protection. in Preprints of Ann. Meet. of Aerosp. Med. assoc., 1974 : 62-3.
- Krutz R.W., Burton R.R., Forster E.M. Physiologic correlates of protection afforded by anti-G suits. Aviat. Space Environ. Med., 1990, 61 : 106-11.
- Lejeune D., Clère J.M., Ossard G., Leger A. Does the anti-G anticipation improve G tolerance. Aviat. Space Environ. Med., 1990, 61 (5): 494.
- Lejeune D., Loncle M. Isolement thermique des équipements PN. RE n° 3 CEV/LAMAS, 1993.
- Meeker L.J. Effects on G_z endurance : tolerance of reduced pressure. AGARD, 1991 CP-516 :15.1-15.4.
- Morgan T.R., Travis T.W., Hill R.C., Air force flight experience with the advanced technology anti-G suit (ATAGS). Aviat. Space Environ. Med., 1993, 64 : 405 (abstract).
- Ossard G., Clère J.M., Kerguélen M. Etude de la tolérance humaine aux accélérations +G_z avec deux lois de pressurisation du pantalon anti-G ARZ 830 (70 et 100 hPa/G). C.R.E. n° 1189 /CEV/LAMAS, 1993.
- Ossard G., Bellet J. P., Clère J. M. Evaluation des équipements de protection anti-G du Rafale et d'un pantalon anti-G prototype, en centrifugeuse sous fort jolt. RE n° 45/CEV/SE/LAMAS et EQ/MAI/1994/DR.
- Ossard G., Morgan T. R., McKenzie I., Clère J. M. Interest of low inflation schedules and extended coverage of anti-G suit associated with PBG. Aviat. Space Environ. Med., 1994, 65 : 448.
- Pluta J.C. LOC survey. Flying Safety, 1984: 25-8.
- Poppen J.R., Drinker C.K. Physiological effects and possible methods of reducing the symptoms produced by rapid changes in the speed and direction of airplanes as measured in actual flight. J. Appl. Physiol., 1951, 3 : 204-15.
- Rushmer R.F. A roentgenographic study of the effects of a pneumatic antiblackout suit on the hydrostatic columns in man exposed to positive radial acceleration. Am. J. Physiol., 1947, 151 : 459-68.
- Shaffstall R.M., Burton R.R. Evaluation of a uniform pressure anti-G suit concept. Preprints of 1980 annual Scientific Meeting, ASMA, 12-15 May 1980 : 96-7.
- Wood E.H., Lambert E.H. The effect of anti-Black-out suits on blood pressure changes produced on the human centrifuge. Fed. Proc., 1946, 5 : 115-6.
- Wood E.H., Lambert E.H., Baldes E.J., Code C.F. Effects of acceleration in relation to aviation. Fed. Proc., 1946, 5 : 327-44.

POSITIVE PRESSURE BREATHING FOR G PROTECTION (PBG)

Wing Commander A.R.J. Prior MBE BSc PhD MB BS

Royal Air Force School of Aviation Medicine,
 Farnborough, Hampshire, GU14 6SZ. UK

ABSTRACT

Modern, high performance, combat aircraft are capable of high sustained +Gz acceleration, at high G onset rates, for which enhanced G protection of the pilot is required if the performance of the aircraft is not to be limited by the capabilities of the pilot. Given that the pilot is essentially seated upright in the cockpit, the most suitable system of enhanced G protection is that of positive pressure breathing (PBG) with the possible addition of new anti-G trousers having considerably greater bladder coverage than previous garments. PBG used with in-service anti-G trousers reduces pilot fatigue and doubles G endurance. An anti-G straining manoeuvre (AGSM) is still required as the relaxed G tolerance of the pilot is increased by only 1G. PBG used with full or extended coverage anti-G trousers enables the pilot to tolerate 8G without needing to employ the AGSM and provides a high degree of protection against G-induced loss of consciousness. However, the increased bladder coverage of the trousers, and that of the chest counterpressure garment which is probably required for PBG, imposes a higher heat load on the pilot and has a tendency to reduce mobility. In addition, the oxygen mask must be capable of effecting an adequate seal of the PBG pressure against the face without user intervention, furthermore the system must be compatible with helmets containing display and sighting systems and be capable of use with NBC protective systems. Development PBG systems have yet to be fully optimised and their routine use by aircrew requires further assessment particularly with regard to the longer term consequences.

INTRODUCTION

With the advent of high performance, fly-by-wire, combat aircraft capable of sustained +Gz acceleration in excess of 9G, and at G onset rates greater than 15G/s, the need for an anti-G system to provide the pilot with enhanced protection in keeping with the performance of the aircraft was identified.

This need was largely stimulated by the high incidence of G-induced loss of consciousness (G-LOC), some 30% of F16 aircrew stated that they had experienced G-LOC in flight (Pluta, 1986), and the increasing number of fatal aircraft accidents attributed to G-LOC. An in-flight recording of arterial blood pressure during G-LOC is shown in figure 1. In several air forces a formal programme of centrifuge based high G training of fast-jet aircrew was instigated in an attempt to reduce the incidence of G-LOC. Meanwhile, the development of an anti-G system designed to enhance pilot G protection followed from research programmes of which the technique of positive pressure breathing was shown to be the most suitable in terms of implementation, protection afforded and pilot acceptability. However, as a technique to be used in isolation it was somewhat misrepresented as the solution to combat G-LOC.

Positive pressure breathing (PPB) is the application of pressure by a regulator to the breathing gas throughout the respiratory cycle. Currently, it is used operationally for emergency hypoxia protection on exposure to altitude above approximately 12,000 meters and as such is now known as positive pressure breathing for altitude protection (PBA). When the application of PPB is used for its ability to enhance G protection it is known as positive pressure for G protection (PBG). Thus, both PBA and PBG are the same technique but, from a subjective point of view, the techniques feel quite different from one another to the extent that a case could be made for renaming PBG so that aircrew in particular do not prejudge PBG adversely as a result of their personal experience of PBA. Whereas PBA, breathing at a pressure of, for example, 45 mmHg causes a reversal of breathing effort between inspiration and expiration, a feeling of fullness in the face and neck and is generally described as a moderately unpleasant experience, that of PBG, at the same breathing pressure, is virtually transparent to the user as a result of the concomitant application of G.

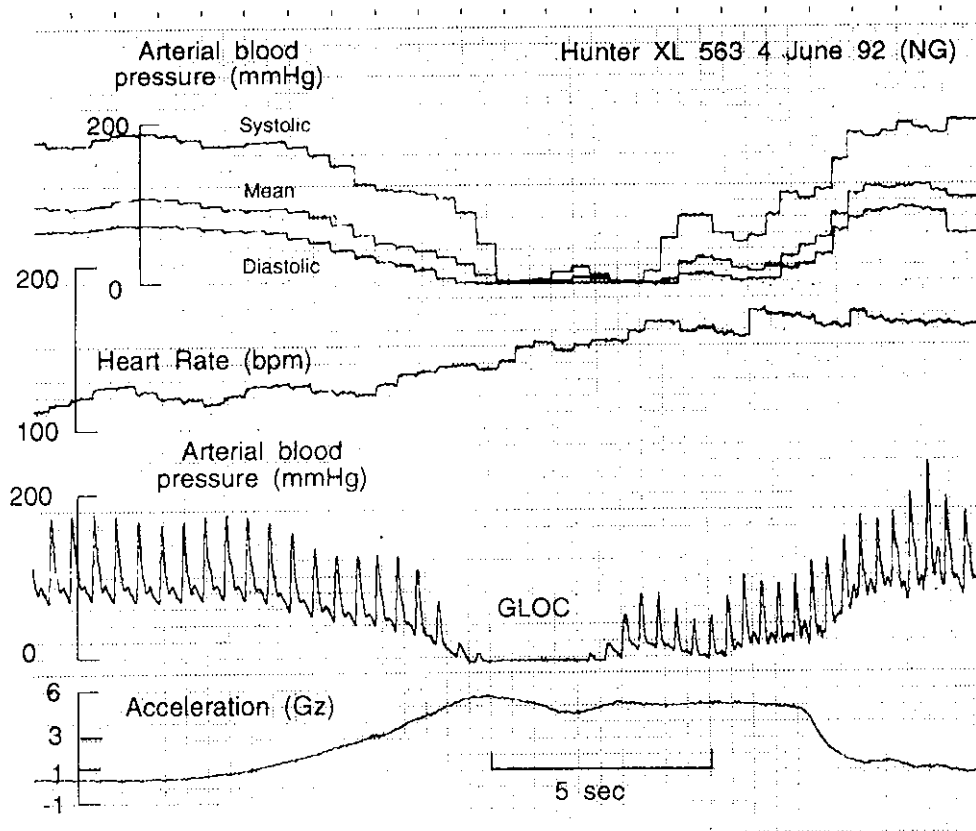

Figure 1. An in-flight recording of neck level arterial blood pressure during an occurrence of GLOC in the subject passenger. Note that the acceleration preceding the event was less than 1Gz.

PHYSIOLOGY OF PRESSURE BREATHING

Positive pressure breathing as a means of protection against the effects of hypoxia associated with exposure to altitudes above 12,000m is a well established technique and was described in the open literature by Gagge et al (1941). Its use as a means of providing protection against +Gz acceleration was described by Wood and Lambert (1952) but the details are scant. He found that PPB had no appreciable effect upon G tolerance, but the protective value of an anti-G suit was enhanced when the subject was pressure breathing.

Lung mechanics

The breathing of oxygen under pressure as an emergency procedure for altitude protection has the desired effect of increasing oxygen tension but also has effects upon the cardiovascular and respiratory systems which limit the level and duration of pressure breathing. In a subject who is instructed to relax his respiratory muscles, the lungs are fully distended at 20 - 25 mmHg pressure breathing and if the pressure exceeds 80 - 100 mmHg tearing of the lung parenchyma can occur (Henry, 1945). Under normal conditions, however, the expiratory

muscles are contracted throughout the respiratory cycle during pressure breathing and 30 mmHg mask pressure can be tolerated for 10 - 20 minutes. Above this pressure, breathing becomes very difficult and fatigue sets in rapidly. There is also a tendency for respiratory minute volume to increase with a corresponding fall in alveolar PCO₂.

Hypertensive effect of PPB

The physiological effects of PPB at 1G, for altitude protection, are described in detail by Ernsting (1966). Of direct relevance to G protection are his observations of the hypertensive effects of PPB. He reports that the elevated intrapleural pressure is applied directly to the heart and intrathoracic great vessels causing an initial rapid rise in arterial blood pressure equal to the increase in intrapleural pressure. This response, at 1G, was followed by a slight fall in mean arterial blood pressure and pulse pressure as a decreased venous return reduced the cardiac output. Approximately 10 - 15 seconds later, arterial blood pressure increased again, although the pulse pressure was still reduced, due to a resumption of venous return as limb venous pressures increased to that of the applied breathing pressure. With

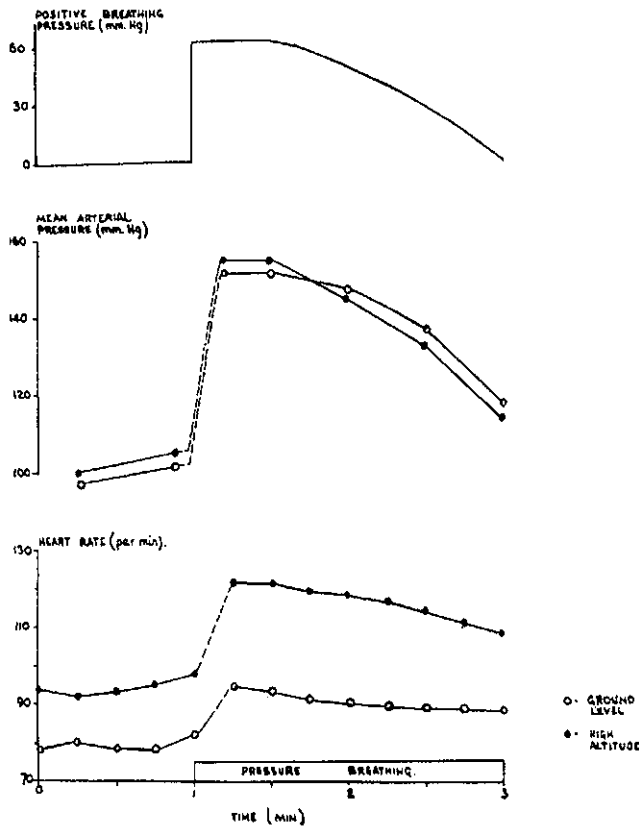

Figure 2. A sustained increase in arterial blood pressure results from the application of pressure breathing at 1Gz (PBA). From Ernsting (1966).

continuous PPB a sustained increase in mean arterial blood pressure of 50 - 100% of the level of applied breathing pressure was observed (figure 2).

When exposed to increased +Gz acceleration it is the reduction in head level arterial blood pressure that is the prime cause of symptoms. Therefore, any technique which results in an elevation of arterial blood pressure is likely to be of benefit under these circumstances and have the effect of improving G tolerance. In this way the G protective benefits of PBG are similar to those of the AGSM. The increased intra-pulmonary pressure is transmitted to the left ventricle and intra-thoracic vessels, and results in an increase in systemic arterial pressure. However, the high intra-thoracic pressure can impair venous return, so tending to compromise cardiac output and decrease systemic arterial blood pressure unless lower body counterpressure is applied, in the form of anti-G trousers, so as to maintain the pressure gradient between peripheral venous and central venous blood pressures.

Pressure breathing also tends to support the respiratory system during +Gz acceleration by reducing inspiratory breathing resistance and increasing the overall breathing volume of the lung. Gas exchange is thus improved by reducing the

effects of increased closing volume and increased weight of the thoracic wall associated with increased +Gz acceleration. High inspiratory volumes are also likely to assist the performance of an anti-G straining manoeuvre (Cote et al, 1986).

The possible routine use of pressure breathing as a means of enhancing G protection for aircrew has given rise to the voicing of safety concerns over the increased intrathoracic vascular pressures and potential risk of air embolism and rupture of the tympanic membrane (Jennings and Zanetti, 1988). In this paper, however, the authors fail to acknowledge the fact that although the pressures within the heart, the great veins and pulmonary circulation are raised, the transmural pressure remains normal and no additional work is placed upon the heart. Furthermore, pressure breathing has been used routinely for many years, both in altitude studies and aircrew training, at pressures up to 70 mmHg without there being any adverse effects. Therefore, it is concluded that the concerns expressed by Jennings and Zanetti are unfounded.

Effect of chest counterpressure

Ernsting (1966) further demonstrated that, at 1G, the increase in arterial blood pressure for any given level of breathing pressure was greater, with less reduction

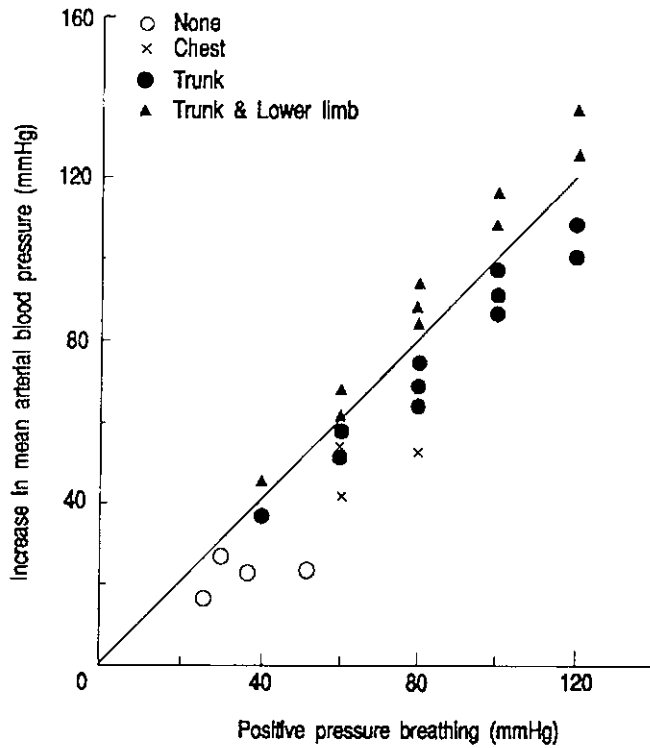
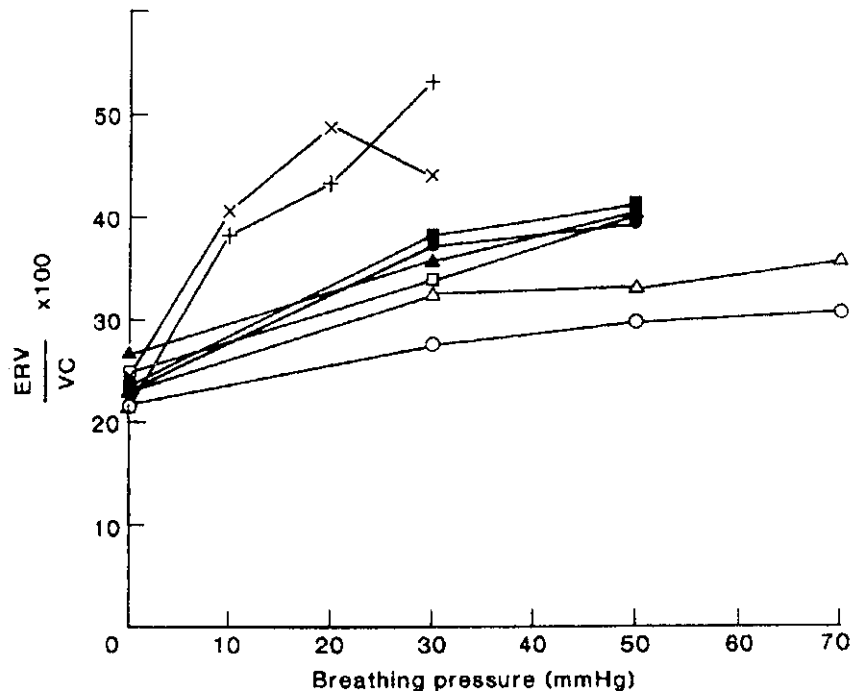

Figure 3. The effect of different extents of counter pressure coverage on the rise in arterial blood pressure induced by positive pressure breathing. From Ernsting (1966).

Key:

- x No counter pressure
- + Vest
- Waistcoat (Laced)
- Waistcoat (Laced) + anti-G Trousers (1:3)
- Waistcoat (Velcro) front bladder only
- Waistcoat (Velcro) front and back bladders
- ▲ Jerkin
- △ Jerkin + anti-G Trousers (1:1)

Figure 4. The effect of different degrees of chest counter pressure coverage on the ratio of expiratory reserved volume to vital capacity. The ratio is used as an estimate of lung distension during positive pressure breathing at 1G. From Brown (1990).



of pulse pressure, with the addition of chest counterpressure to PPB. Still greater increases in mean arterial blood pressure were attained by whole trunk and whole trunk plus limb counterpressure (figure 3). With the latter combination, arterial blood pressure increases in excess of the applied breathing pressure were observed, reaching 125% of the PPB pressure. Such chest or trunk counterpressure decreases lung distensibility during PPB resulting in a greater increase in intrapleural pressure at the same airway pressure.

Breathing against positive pressure tends to reduce the inspiratory reserve volume although the total lung capacity is increased and, in order to prevent lung over-distension when the applied breathing pressure exceeds 30 mmHg, chest counterpressure is required. An ideal counterpressure garment would maintain the sub-divisions of lung volume at similar levels to those observed whilst breathing at ambient pressure. Brown et al (1990) used the ratio of expiratory reserve volume (ERV) to forced vital capacity (VC) as a measure of lung distension during pressure breathing using different coverage chest counterpressure garments. Their results, shown in figure 4, indicate that not only is the coverage of the garment important in determining lung distension but also that the presence of inflated anti-G trousers has a marked effect. The minimum coverage of a chest counterpressure garment for PBA is generally accepted to be that of a waistcoat. Whether the

waistcoat should comprise inflatable bladders over both the front and back of the thorax, or just over the front, is still a matter of debate.

During PBG the situation differs in that, whilst under G, the weight of the chest wall and any protective clothing over it, for example a life preserver, contribute markedly to the effective counterpressure acting to prevent over-distension of the lungs. Thus, if a similar experiment to that of Brown (1990) is performed whilst using PBG at 5, 7 and 9Gz with either no chest counterpressure, full waistcoat or backless waistcoat, no significant difference in lung volume is found when compared to the control condition of no PBG. Figure 5 shows the results obtained by Green (1994). These results should not be regarded as sufficient evidence for the disposal of a chest counterpressure garment for PBG as there is no measurement of regional lung distension. Considerably more work is required before definite recommendations can be made safely although the evidence to date does point to the chest counterpressure garment being unnecessary under these conditions.

Effect of lower body counterpressure

Pressure breathing under 1Gz conditions, for altitude protection, results in the displacement of blood volume to the periphery of the body as a direct result of the raised intra-thoracic pressure. As shown in

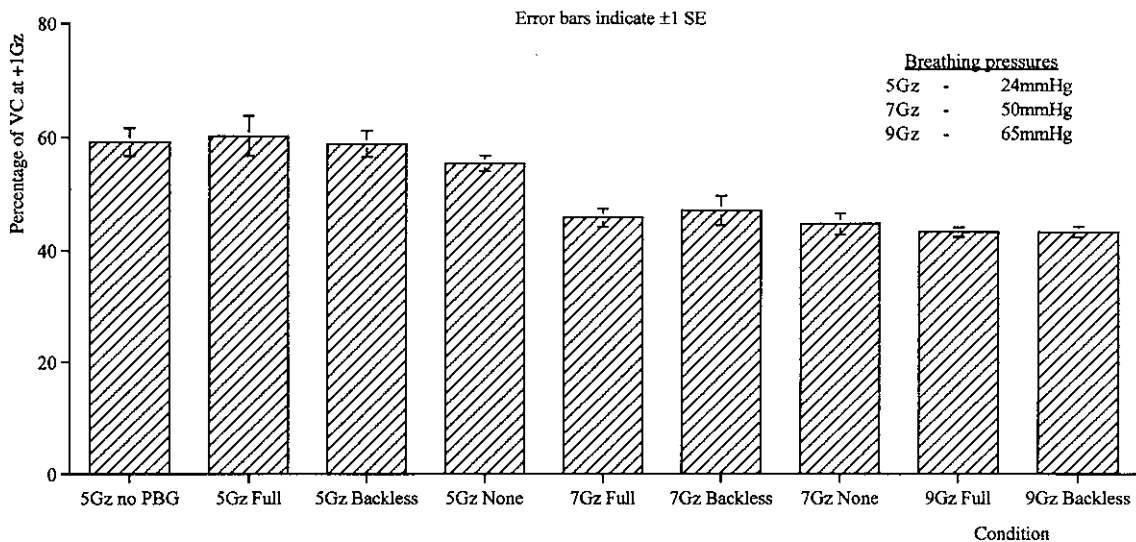

Figure 5. The effect of different degrees of chest counter pressure garment coverage upon lung distension, as expressed as a percentage of the subject's vital capacity at 1Gz, at 5, 7 and 9Gz. There is no significant difference between the conditions of no PBG, full chest coverage, coverage of the front of the chest only and no chest counter pressure. From Green (1994).

Figure 6. The reduction of effective blood volume as a consequence of a high intrathoracic pressure induced by positive pressure breathing. In time, the loss of effective blood volume leads to pressure breathing syncope. From Ernsting (1966).

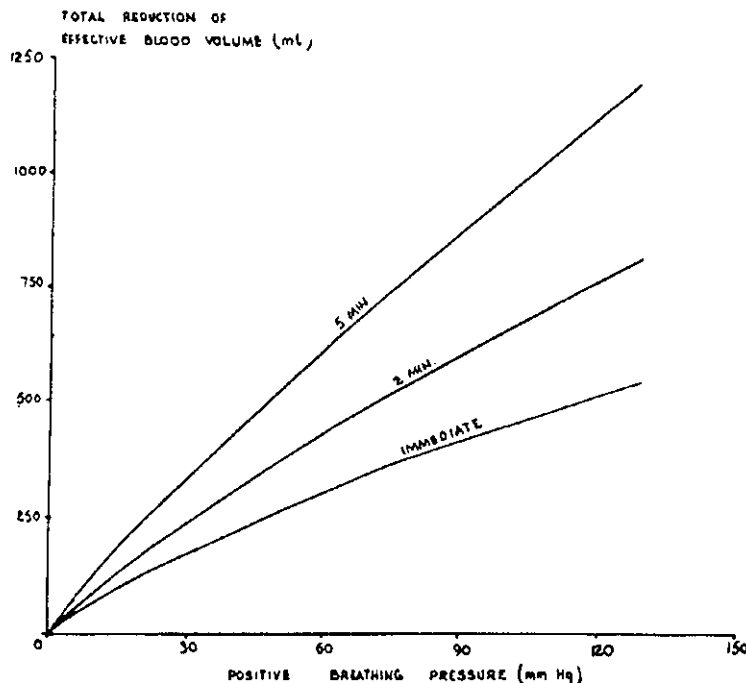

figure 6, from Ernsting (1966), the reduction in effective blood volume rises with increasing breathing pressure and increases with the duration of applied pressure breathing leading to the condition of pressure breathing syncope. Under increased +Gz acceleration there is already a marked tendency to peripheral venous pooling as a result of the increased hydrostatic pressure applied to the peripheral vasculature and, with the application of PBG, there is further loss of effective blood volume. Thus, with PBG although the raised intra-thoracic pressure tends to increase arterial blood pressure, the venous pooling which it also induces leads to reduced cardiac output. Without lower body counterpressure the result is a fall in arterial blood pressure and syncope but with conventional, in-service, anti-G trousers providing support to the circulation there is

a net increase in arterial blood pressure and so an improvement in G protection.

In respect of raising arterial blood pressure, PBG tends to act against itself and the outcome is determined by the balance between its direct hypertensive effects and those tending to induce venous pooling. The balance can be modified by changing both the applied breathing pressure and the effectiveness of the lower body counterpressure in preventing, or indeed reversing, venous pooling. Prior (1991) measured the changes in lower body blood volume at different +Gz accelerations with different coverage anti-G trousers whilst pressure breathing at 30 mmHg. The coverage of the anti-G trousers used is shown diagrammatically in figure 7

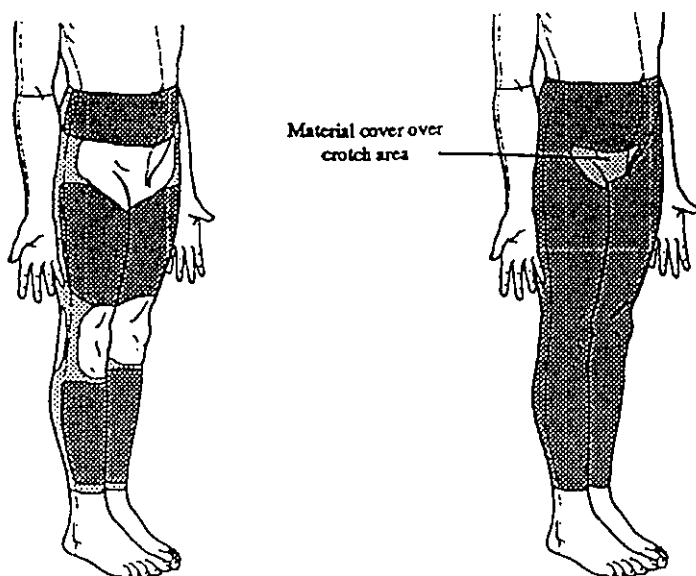

Figure 7. Schematic diagram of the bladder coverage of standard, in-service, anti-G trousers and developmental full coverage trousers.

Change in lower body blood volume (%)

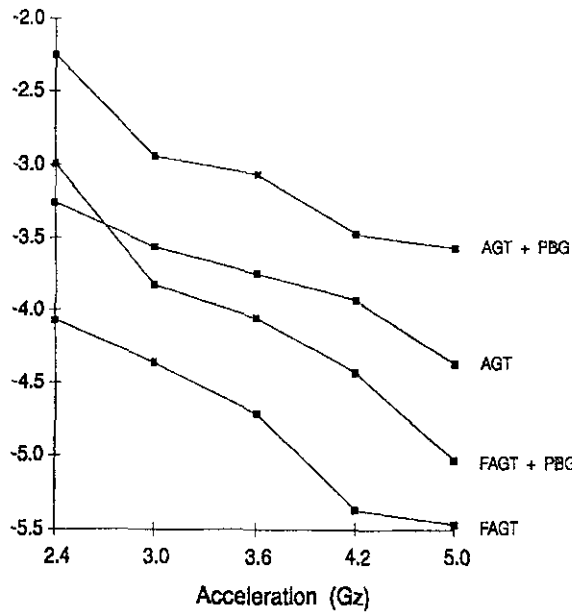

Figure 8. The reduction in lower body blood volume which ensues following inflation of either full coverage (FAGT) or normal coverage (AGT) anti-G trousers whilst under G and with, or without, PBG applied at 30mmHg pressure. From Prior (1991).

and the blood volume changes in figure 8. In the case of both garments their inflation results in the displacement of blood headwards and the addition of 30 mmHg pressure breathing reduces the magnitude of the shift in blood volume. However, the greater coverage anti-G trousers produce a larger change in blood volume both when used alone and in conjunction with pressure breathing. The resulting change in eye level arterial blood pressure on exposure to G is shown in figure 9. Relative to the use of standard coverage anti-G trousers alone, the addition of 30 mmHg PBG and the use of full coverage anti-G trousers (FAGT) both reduce the fall in blood pressure due to the applied Gz acceleration. When FAGT are used with PBG the arterial blood pressure fall is reduced markedly, indeed at 2.5 and 3.0Gz there is an increase in eye-level blood pressure under G. The full coverage anti-G trousers are far better at providing counterpressure to the lower body the result of which is manifest as a better preservation of eye-level arterial blood pressure whilst under G and using PBG. The efficiency of the system can be expressed as the ratio of applied breathing pressure to the rise in arterial blood pressure so that a 30mmHg rise in blood pressure as a result of 30mmHg PBG would be

Change in mean eye level arterial blood pressure (mmHg)

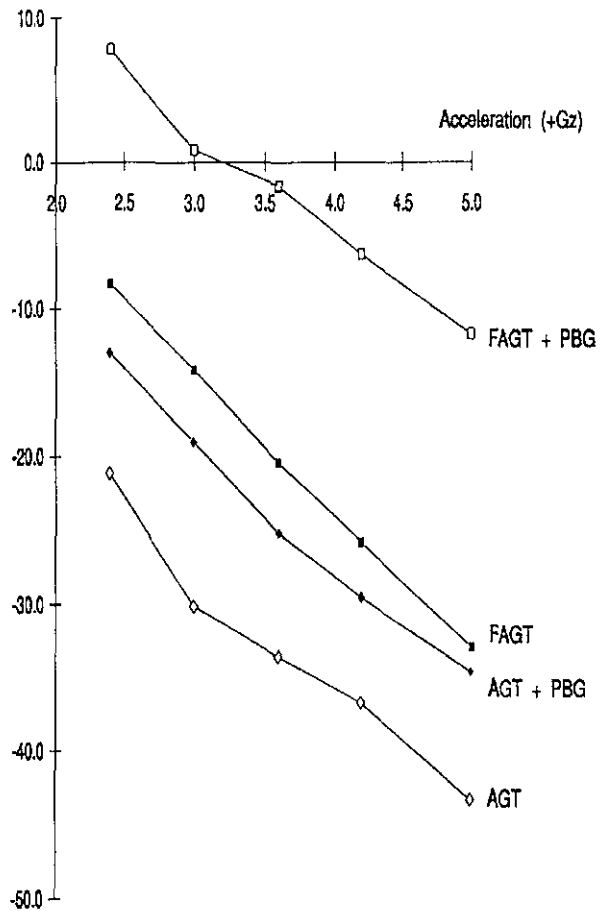

Figure 9. Eye level arterial blood pressure changes under G comparing the use of full coverage anti-G trousers (FAGT) or an in-service garment (AGT) with, and without, the addition of PBG at 30mmHg pressure. From Prior (1991).

regarded as 100% efficient. Figure 10 shows the difference between standard coverage and full coverage anti-G trousers in terms of the hypertensive efficiency of PBG where it can be seen that the latter garment allows the hypertensive effect of PBG to be more fully realised.

EFFECT OF PBG ON G TOLERANCE

PBG has been compared to the M-1 manoeuvre for its efficacy in augmenting G tolerance (Shubrooks, 1973). He found that PBG, at a pressure of 25 - 35 mmHg started 30 - 40 seconds before the onset of acceleration, increased relaxed G tolerance by 0.3 - 1.5G. This was not significantly different to that resulting from an M-1 manoeuvre performed without muscle tensing. With PBG raised to 40 mmHg pressure and generalised muscle tensing added to both the PBG and M-1 conditions, an increased tolerance of 0.7 - 2.2G resulted from pressure

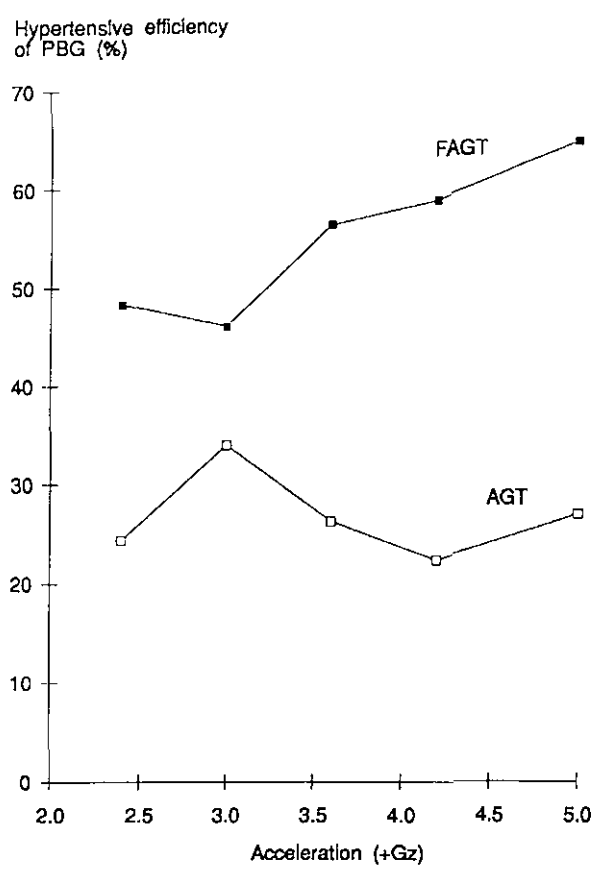

Figure 10. The "hypertensive efficiency" of PBG using either conventional (AGT) or full coverage (FAGT) anti-G trousers. From Prior (1991).

breathing. The mean increase in G tolerance was 1.2G and did not differ significantly from the protection given by an M-1 manoeuvre. When PBG was used in conjunction with an anti-G suit during an 8G exposure for 45 seconds it was noted that the performance of an AGSM was far less fatiguing than when PBG was omitted.

Similar results have been found both on the human centrifuge and during flight testing of a PBG system. Leverett et al (1973) used a breathing pressure of 30 mmHg at accelerations above 2Gz during 60 second exposures to 3, 6 and 8G. They confirmed that there was no difference in G protection between PBG and performing an M-1 manoeuvre but fatigue was less during the pressure breathing. They also noted that arterial oxygen saturation was better maintained during PBG. Glaister and Lisher (1976) found PBG of 5 mmHg per G improved G tolerance by 0.8G on the centrifuge. They proceeded to install the PBG system in a Hunter aircraft to investigate the usefulness of PBG in the air and to canvas aircrew opinion of the technique. Generally, aircrew were enthusiastic of the system, finding fatigue under G

to be reduced. Glaister and Lisher used a PBG system that is noteworthy in being the first to provide breathing pressure which increased in proportion to the +Gz acceleration. They had derived the pressure breathing schedule from observations made during investigations into the use of seat reclination for improved G protection, where pressure breathing was used to offset inspiratory difficulty arising from the increased weight of the chest wall under G. The system was arranged so that PBG cut-in abruptly at 2.5G, generating a mask pressure of 12.5 mmHg. However, during the flight trials this feature was found by aircrew to be particularly distracting and withdrawal of this particular feature of the pressure breathing schedule was requested.

Shaffstall and Burton (1979) investigated the value of providing chest counterpressure during positive pressure breathing for G protection. Up to this time experiments involving PBG had not included any garments specifically for the purpose of providing chest counterpressure. The breathing pressures involved had been relatively low and, to some extent, the increased weight of the chest wall under G fulfilled the role of a counterpressure garment. Shaffstall and Burton adopted the terms 'assisted' and 'unassisted' PPB for the conditions of pressure breathing under G with and without a chest counterpressure garment inflated to a pressure equal to that delivered to the oro-nasal mask. Using a simulated air combat manoeuvre (SACM) on the centrifuge, comprising repeated cycles between 4.5 and 7.0 Gz of 10 seconds duration at each G level, they found the tolerance time for this manoeuvre was increased by 27% when pressure breathing was augmented with chest counterpressure. There was no significant difference between the tolerance times for the conditions of anti-G trousers alone and unassisted PPB. It should be noted, however, that the method of delivery of pressure breathing differed from that used by Glaister and Lisher, PPB was delivered to the mask at a pressure of 30 mmHg, commencing 20 seconds before the onset of acceleration rather than increasing mask pressure in proportion to the prevailing +Gz acceleration.

Burns and Balldin (1983), however, used an assisted pressure breathing system which 'cut-in' at 1.2 Gz and increased mask pressure linearly to either 50 mmHg or 70 mmHg at 9.0Gz. They also used a centrifuge SACM profile and measured subjects' tolerance time of exposure to these repeated cycles of high G. Paradoxically, they found tolerance time, compared to the control condition of anti-G Trousers

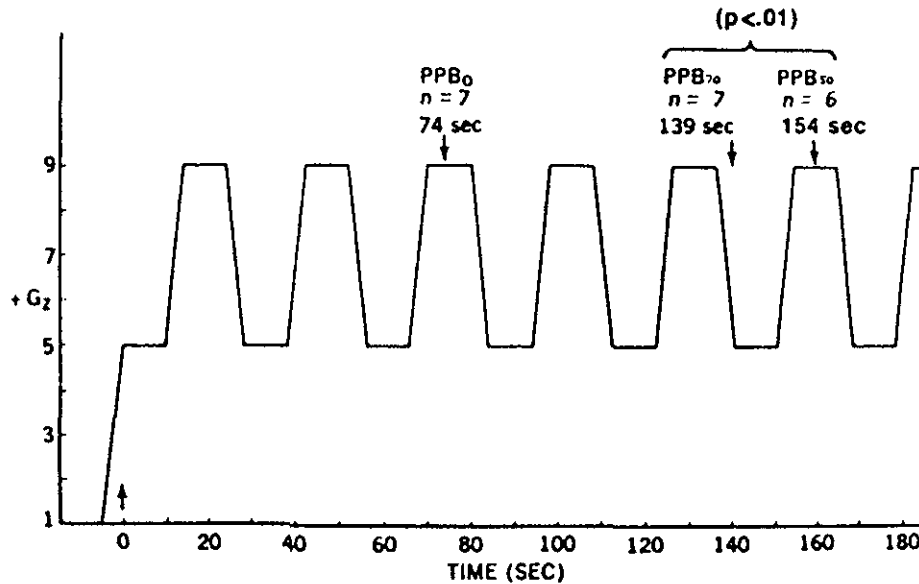

Figure 11. G endurance time during a simulated air combat manoeuvre, without PBG (PPB₀), with PBG at 17mmHg (PPB₇₀) or 50mmHg (PPB₅₀). From Burns and Balldin (1983).

only and straining, to be increased by 115% whilst pressure breathing to a maximum mask pressure of 50 mmHg but only an 88% increase with the higher pressure schedule (figure 11). The higher intrathoracic pressure generated by higher mask pressures would have been expected to cause a greater rise in arterial blood pressure so improving G tolerance. They attributed their findings to discomfort caused by a tightly fitted mask necessary to seal the higher pressures. Although not considered by the authors, it can be postulated that the degree of counterpressure to the lower body was inadequate in its support of the circulation at the higher mask pressures, so preventing the full hypertensive effects of pressure breathing to be realised.

Bagshaw (1984) conducted flight trials with a PBG schedule of 5 mmHg/G, starting at 4 G during increasing G, and terminating at 3 G during decreasing G. The press-to-test facility of the oxygen regulator was modified to deliver 100% oxygen during PBG, but deliver airmix before and after G. With instructions that straining could be added if needed, 71% of pilots felt that PBG increased tolerance to air combat manoeuvres and was more effective than using an AGSM, furthermore less fatigue was felt afterwards. The abrupt cut-in/cut-out of PBG at 4/3Gz was considered to be less than ideal.

In early 1987, USAF conducted flight trials in an F-16 aircraft fitted with prototype assisted PBG

systems designed to assess their G protective capability and effects on aircraft operation. This technology had been developed from the work of Burns and Balldin at USAFSAM using 50 and 70 mmHg at 9 G. The three pilots strongly endorsed PBG as an anti-G system, feeling that they were well-protected and probably could tolerate G loadings for longer durations and at greater than present limits. The prototype PBG systems, however, limited pilot mobility and comfort.

Several other studies into the efficacy of pressure breathing with chest counterpressure have been made, both on the centrifuge and in the air. Universally, the technique has been found to be of benefit in terms of reducing the amount of effort required to strain under G, thus reducing fatigue and so allowing subjects and pilots to pull G for longer. The delivery pressure schedules differ in all studies, both for the maximum pressures used and the acceleration at which pressure breathing first starts. However, all investigators have employed a linear rise of pressure with G between the cut-in point and maximum pressure. The studies also have in common the extent of lower body counterpressure; all have used standard, in service anti-G trousers appropriate to their country. They are all of similar design and are inflated with more or less the same pressurisation schedule (Domazuk, 1983; Bagshaw, 1984; Harding and Cresswell, 1987; Cresswell et al, 1988; Clere et al, 1988; Balldin et al, 1989).

During the 1950s, when attention was focused on providing high altitude protection for aircrew, many improvements were being made to full pressure suits so that they became potentially suitable for G protection. Seiker et al (1953) compared the protection given by RAF cutaway anti-G trousers with that of trousers having circumferential bladders and full coverage finding that it improved G protection by some 2.6G. With the more recent upsurge of interest in providing aircrew with improved G protection, full coverage garments have been re-examined and, of course, renamed giving rise to a number of variants known as Advanced Technology Anti-G Suit (ATAGS), Uniform Pressure Suit (UPS) or Full Coverage Anti-G Trousers (FAGT). It is when the enhanced lower body counterpressure provided by these garments is used in combination with PBG that dramatic improvements in G protection are seen.

Whereas the use of PBG with conventional coverage anti-G trousers enhances G endurance, in that the amount of effort required in performing an anti-G straining manoeuvre is much reduced, the improvement in relaxed G tolerance is small. Therefore, unless it is advocated that physical fatigue is an important factor in G-LOC, such a system is unlikely to be successful in reducing the incidence

of loss of consciousness. However, the combination of PBG and anti-G trousers using full coverage, circumferential bladders results in a relaxed G tolerance of 8.3G and allows 9G to be tolerated for several minutes with only minimal leg tensing effort being required intermittently to maintain full vision (Prior, 1989). Figure 12 shows a comparison of the relaxed G tolerances resulting from the use of conventional anti-G trousers (AGT) and full coverage G trousers (FAGT), with and without the addition of PBG. It can be seen that the use of PBG with AGT offers about 1G improvement in relaxed G tolerance and is comparable to the use of FAGT alone whereas the addition of PBG to FAGT allows a substantial improvement in tolerance and is in keeping with the findings concerning PBG hypertensive efficiency described in a previous section. It should be noted that although 9G can be tolerated with relative ease and clear vision, the eye-level arterial blood pressure is only just sufficient to maintain adequate retinal perfusion (figure 13). Any reduction in either the extent of anti-G trouser coverage or the level of breathing pressure available at a given acceleration is likely to result in substantial grey-out at 9Gz. In this context it is important to consider the flow characteristics of the PBG delivery system and its ability to maintain mask cavity pressure demand inspiratory flows (see below).

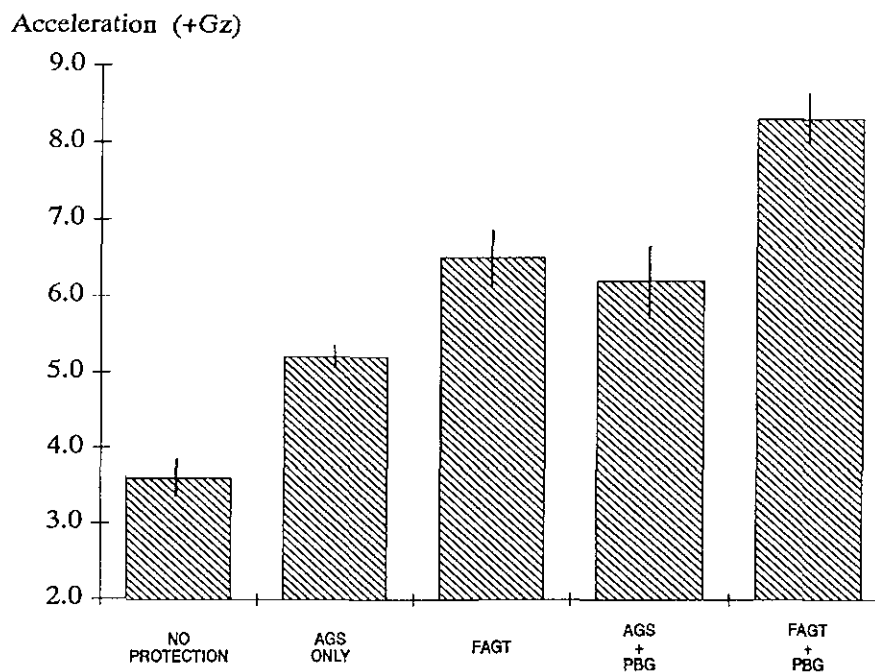

Figure 12. Relaxed G tolerance using either conventional (AGS) or full coverage (FAGT) anti-G trousers with, and without, PBG of 2G cut-in, 11mmHg/G. From Prior (1989).

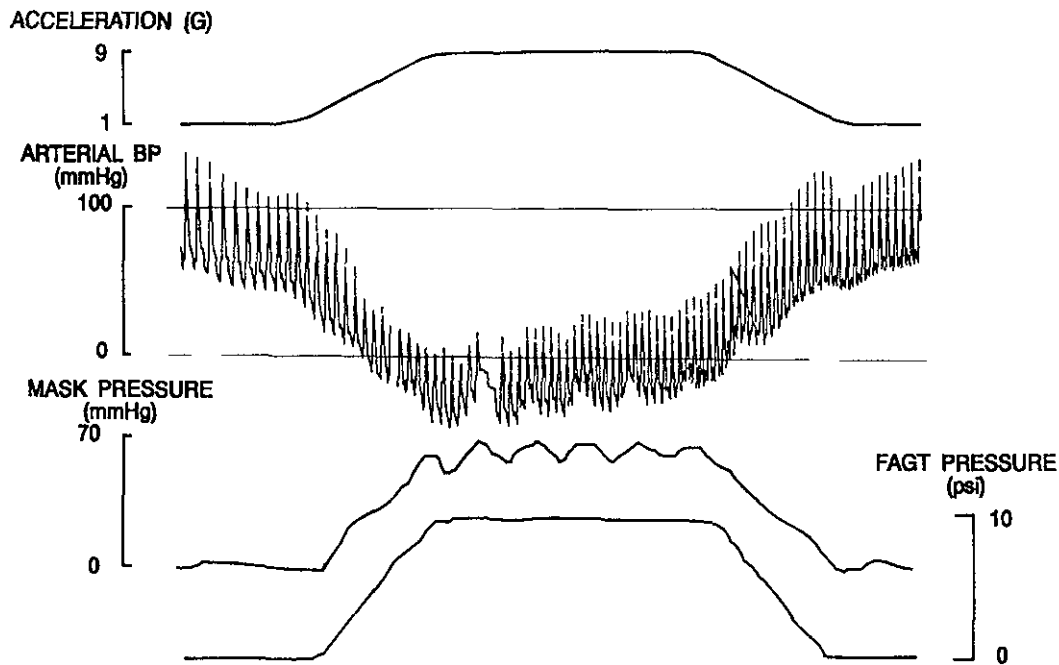

Figure 13. Eye-level arterial blood pressure, measured using Finapres, during a 9Gz centrifuge run using full coverage anti-G trousers and PBG at 65mmHg. The subject reported no loss in vision and remained relaxed (non-straining) throughout the run.

IMPLEMENTATION OF PBG

The usual arrangement for the implementation of a PBG system is shown in figures 14 and 15. A pneumatic signal is taken from the anti-G valve outlet and is fed to a 'G' module attached to the breathing regulator which responds by supplying positive pressure proportional to the magnitude of the pneumatic signal. Thus there is a sequence in which G is applied, the anti-G valve responds according to its specified pressurisation schedule, the anti-G valve outlet pressure is fed to the breathing regulator which then provides PBG according to a predefined

schedule of pressurisation. This arrangement has been adopted in view of the fact that the use of PBG in a high G environment without functioning anti-G trousers severely compromises the pilots ability to tolerate G. Also, it should be noted that if there is a complete failure of the anti-G trousers then PBG automatically ceases. When using a system comprising full coverage anti-G trousers and PBG, and so not performing any straining manoeuvre, if such a failure occurs at 9Gz then G-LOC ensues after a delay of approximately 2 seconds.

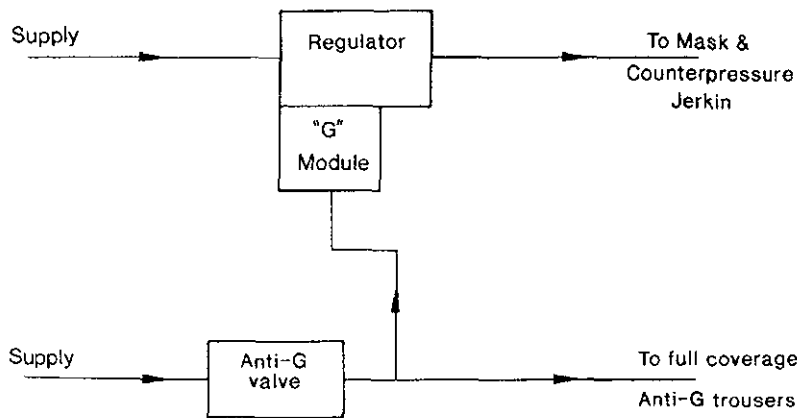

Figure 14. Schematic diagram of a typical PBG system in which the anti-G valve outlet pressure signals the breathing regulator to supply pressure breathing in proportion to the applied Gz acceleration.

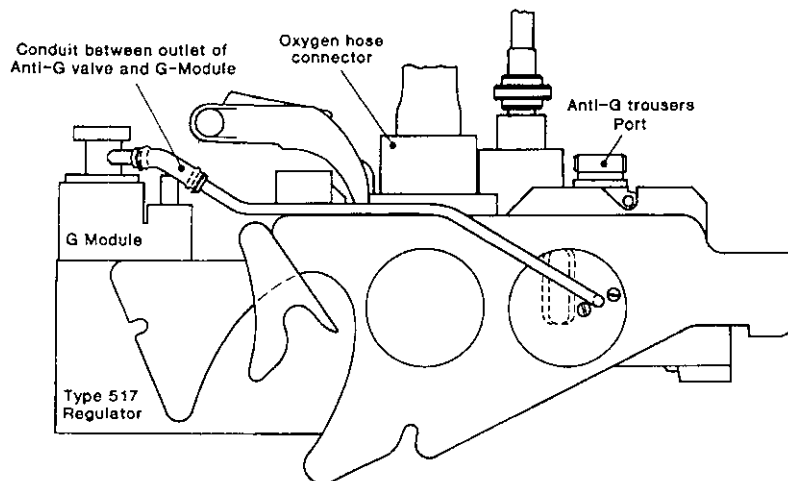

Figure 15. An implementation of the schematic diagram shown in figure 14. This arrangement is currently fitted to the RAF School of Aviation Medicine Hawk aircraft.

The current UK PBG regime is shown in figure 16 and is slightly unusual in that PBG starts at 2G, in most other systems a value of 4G has been chosen. It is most likely that the schedule will be changed in the near future to cut-in between 5G and 6G based on the general statement that G protection in excess

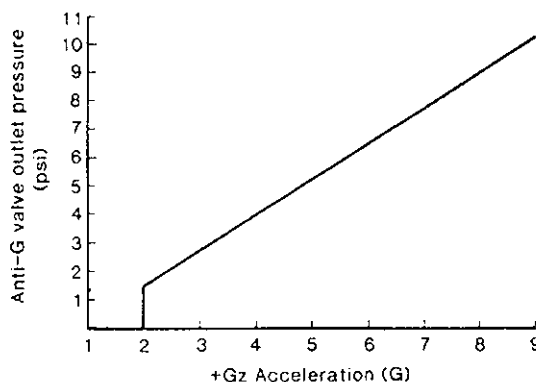
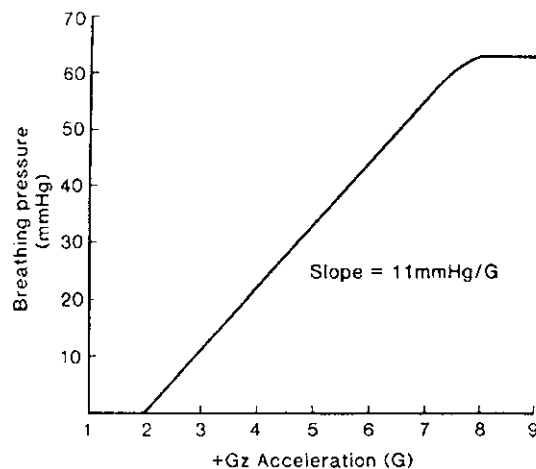

Figure 16. Current UK PBG and anti-G valve pressurisation schedules. These schedules are used in the RAF School of Aviation Medicine Hawk aircraft and as an interim system for EF2000.

of that required by the pilot is unnecessary and undesirable. At 9G most PBG systems provide a breathing pressure of between 50 and 70mmHg. Generally speaking the higher the pressure the better the protection afforded, providing there is adequate lower body counterpressure. Other considerations such as comfort, ease of breathing, the ability to talk, mask sealing and arm discomfort are also taken into account when deciding upon the optimum schedule. Work in this area has been performed on a largely empirical basis and has given rise to a variety of PBG schedules used by different air forces. To date no PBG is yet in service although the French Rafale, the UK, German, Spanish, Italian Eurofighter 2000 and the Swedish Gripen soon enter service all with PBG specified. In the USAF there is currently a programme to retrofit the F16 and F15 aircraft with PBG and the Finnish Air Force, Canadian Air Force and US Navy are to install PBG in their F18 aircraft. Much valuable information will be gained once these aircraft are flown using PBG routinely and it is likely that the various PBG schedules will come into accord in the light of pilot opinion.

Of the new aircraft entering service with PBG, all also have a high altitude capability which requires the pilot to be protected by PBA. The pressure breathing system has a dual function, providing both PBG and PBA, moreover the PBA system requires that the anti-G trousers inflate such that there is a ratio between trouser and breathing pressure of between 2:1 and 4:1 depending on the individual air force implementation. To further compound the situation these aircraft are also capable of pulling high G at high altitude and so require that the breathing pressure delivered to the pilot is the greater of the PBA and PBG pressures demanded. The breathing regulator is designed to accommodate these requirements, however, the aircraft tend to have

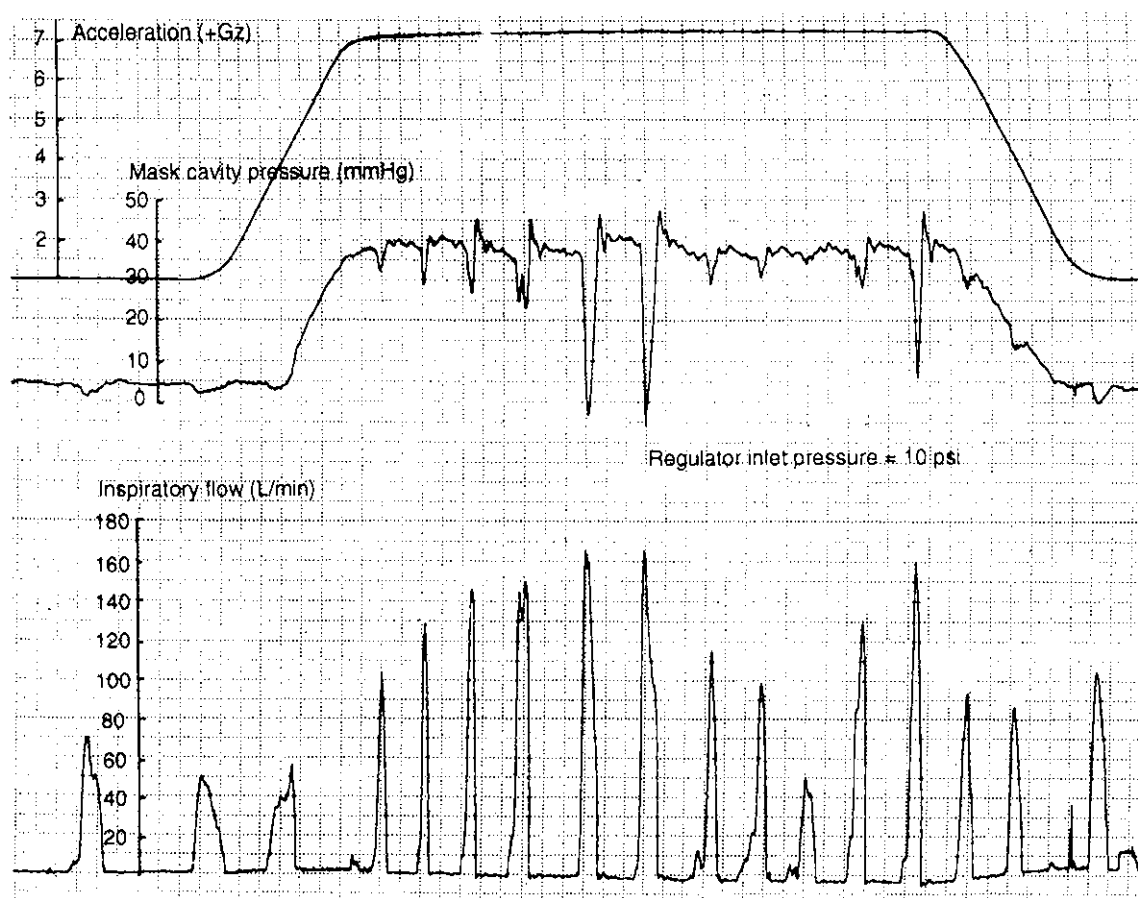

Figure 17. Original trace showing that a demanded inspiratory flow in excess of the capabilities of the regulator causes a fall in PBG mask cavity pressure.

severe space and weight constraints so that there is a need to make the regulators light and compact yet still be capable of meeting the inspiratory flows demanded by the pilot. Figure 17 shows the mask cavity pressure during PBG at various inspiratory flows. If the regulator has an inadequate flow capacity then, as shown, the mask cavity pressure can fall toward zero when even moderate respiratory demands are placed upon it.

DISADVANTAGES OF A PBG SYSTEM

A PBG system adds complexity to the aircraft life support system but this is a comparatively minor disadvantage. Of greater concern is the added aircrew protective clothing required, in particular the chest counterpressure garment and, if full or extended coverage anti-G trousers are employed, the surface area of the body which is covered by impermeable material. The extra bulk, decreased mobility and heat load imposed by such garments are at best a disadvantage and at worse a positive encumbrance which, in the view of some pilots, compromises his operational capability. In this respect the PBG system is the same as any other

protective assembly in that the clothing is only of value if the pilot is exposed to an environment which warrants the protection. In other words, unless high G is pulled on a regular basis, the equipment can be regarded as superfluous. On the other hand, the likelihood of G-LOC, and the possible loss of both aircraft and pilot, increases with the G performance of the aircraft.

With a PBG system the mask must seal against the face to prevent both a loss in mask cavity pressure and either distractingly noisy leaks or leaks which blow into the eyes causing them to run. However, the mask must remain comfortable on the face, not being so tight that it cannot be tolerated for extended periods of time. A variety of automatic mask tensioning systems have been devised which cause the mask to tighten onto the face to effect a seal as PBG is applied in response to Gz acceleration. Two common systems are employed. One is a bladder in the helmet at the nape of the neck, which inflates to the same pressure as the breathing pressure, tending to pull the helmet rearwards and so bring the mask into closer facial contact. The other system is a bladder interposed between the exoskeleton of the

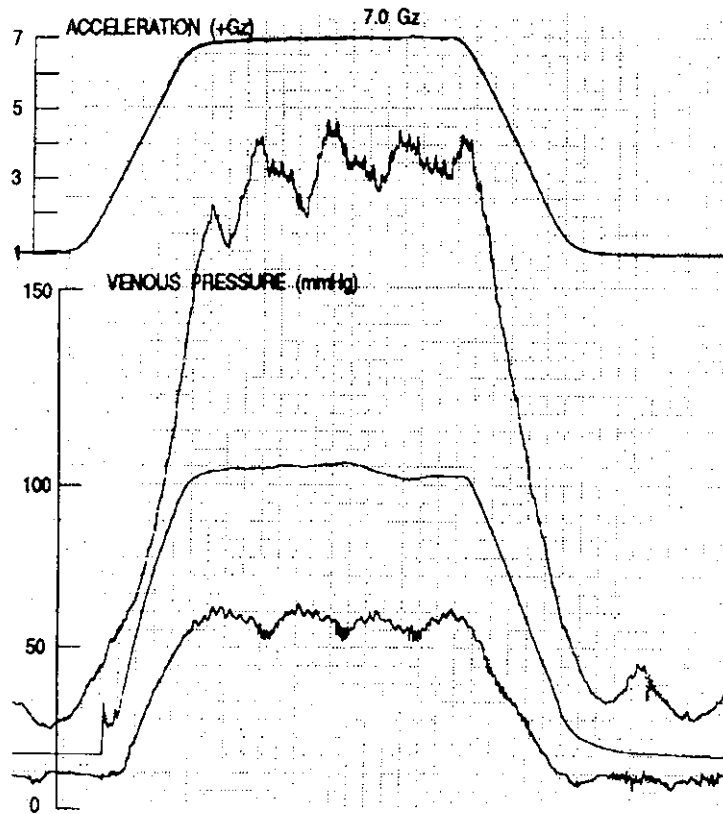

Figure 18. Forearm venous pressure rise during a centrifuge run with the subjects hands positioned 23cm below heart level and exposed to 7Gz with PBG at 55mmHg.

mask and its facepiece such that the inflation of the bladder pushes the facepiece more firmly onto the face. Both systems are currently being assessed by several research laboratories and by industry. However, it is the authors view that neither system is entirely satisfactory as they do not provide reliable mask sealing and are heavily dependent upon an almost perfect helmet and mask fit to the individual. In addition, the latest generation of aircrew helmets incorporates helmet sighting and display systems which require a particularly stable helmet platform

for their satisfactory operation. The mask sealing systems currently employed have a tendency to compromise helmet stability and may not be compatible with the helmet mounted devices. These problems may prove extremely difficult and costly to overcome, possibly leading to the value of PBG being questioned closely.

Under G the venous pressure in the arms is dictated principally by their vertical distance below heart

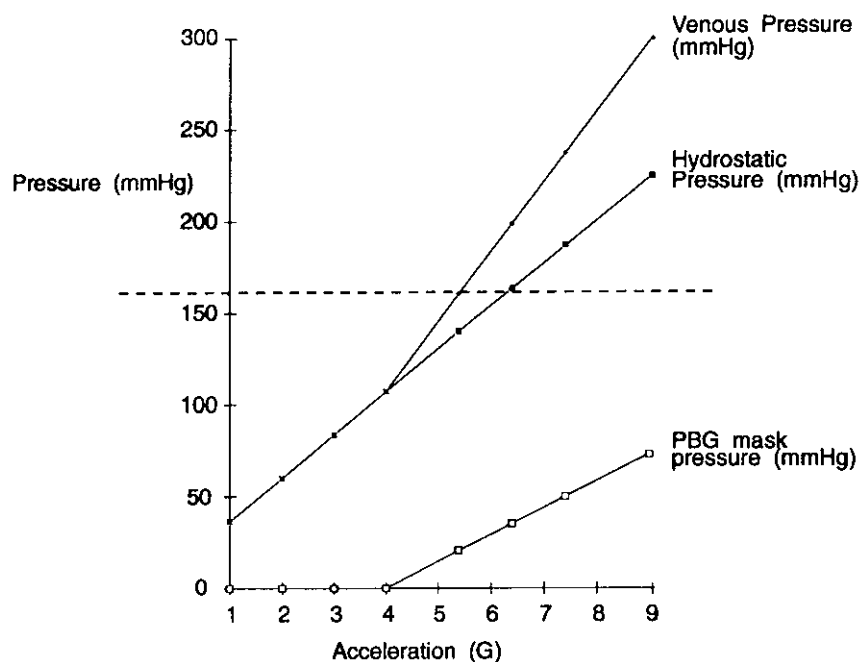

Figure 19. "Model" of forearm venous pressure changes with G showing the hydrostatic and PBG components of the final, predicted, venous pressure.

level and the consequent hydrostatic pressure so generated. Positive pressure breathing raises intrathoracic pressure such that, for peripheral venous return to continue, the venous pressure must rise to exceed that of the applied breathing pressure. Together these two effects determine the arm venous pressure and in the case of an aircraft which has the stick and throttle in a low position relative to the pilots heart, the pressures attained can be sufficiently high to cause either discomfort or overt pain. A typical trace of forearm venous pressure during PBG at 7Gz is shown in figure 18 and a simple model of the situation is depicted in figure 19 in which the contribution of PBG to the overall venous pressure can be seen. Thus, although PBG is not the prime cause of high G related arm pain it is an important contributor.

Previously, mention was made of the concerns expressed by Jennings and Zanetti (1988) with regard to the use of PBG. Their suggestions were regarded as unfounded and, in the case of intravascular pressure change during PBG, viewed as physiologically unsound. However, the long term consequences of the repeated use of PBG are unknown and certainly warrant further careful investigation especially with regard to regional lung distention. It is also quite likely that the use of PBG might exacerbate trivial upper respiratory infections which, in the normal course of events, would go unnoticed by aircrew, or be very minor, only to be turned into something a little more substantial by the use of PBG.

CONCLUSIONS

PBG, especially when used in conjunction with full coverage anti-G trousers, markedly increases the pilots ability to withstand high G and reduces the risk of G-LOC. However, many unknowns remain with the use of PBG ranging from the optimal pressure breathing schedule to long term medical consequences and the basic physiological changes which follow its application. Much will be learnt as the system comes into regular, service use when the extent of the disadvantages stated here become known and generally whether the system is acceptable and of sufficient value to aircrew to outweigh those disadvantages.

REFERENCES

1. Bagshaw, M. A Flight trial of positive pressure breathing during acceleration using RAF Hawk aircraft at a tactical weapons unit. RAF IAM Farnborough, Hants. IAM Report No. 637, October 1984.
2. Balldin, U.I., Dahlback, G.O. and Larsson, L.E. Forsvarets Forskningsanstalt. Full coverage anti-G suit and balanced pressure breathing. FOA Rapport, C 50065-5. 1, February 1989.
3. Brown, G.A., Gradwell, D.P., Harding, R.M. and Lupa, H.T. An evaluation of counter pressure garments by spirometric measurement of lung volume.
4. Burns, J.W. and Balldin, U.I. +Gz protection with assisted positive pressure breathing (PPB). In Preprints of Ann Aerosp Med Assoc, pp 36-37, 1983. (Full report: Aviat Space Environ Med 59: 225-233, 1988).
5. Clere, J.M., Lejeune, D., Tran-cong-chi, D., Marotte, H. and Poitier, J.L. Effects of different schedules of assisted positive pressure breathing on G-level tolerance. Safe Proceedings, 1988: 76-79.
6. Cote, R., Tripp, L., Jennings, T., Karl, A., Goodyear, C., and Wiley, R. Effect of inspiratory volume on intrathoracic pressure generated by an L-1 manoeuvre. Aviat. Space Environ. Med. 57: 1035-1038, 1986.
7. Cresswell, G.J., McPhate, D., Harding, R.M. and Farmer, E.W. Positive pressure breathing with and without chest counterpressure - an assessment in air combat manoeuvring flight. Aviat Space Environ Med 59: 480, 1988.
8. Domaszuk, J. The application of positive pressure breathing for improving +G, acceleration tolerance. Aviat Space Environ Med 54:334-337, 1983.
9. Ernsting, J. Some effects of raised intrapulmonary pressure in man. AGARDograph No 106. Technivision Services, England. 1966.
10. Gagge, A.P., Allen, S.C., and Marbarger, J.P. Pressure breathing. J Aviat Med 16: 2-8, 1945.
11. Glaister, D.H. and Lisher, B.J. Pressure breathing as a means of enhancing tolerance to sustained positive accelerations in Proceedings of a Symposium on Biomedical and Biophysical Aspects of Oxygen

- Systems, 17th Meeting of Air Standardization Coordinating Committee, Working Party 61, pp 138-144, Farnborough, Hants, 1976.
12. Green, N.D.C., Peterson, M.K. and Prior, A.R.J. Lung volumes during +Gz acceleration and positive pressure breathing - can lung over-distension occur? 65th Aerospace Medical Association Annual Scientific Meeting. San Antonio, Texas, 1994.
 13. Harding, R.M. and Cresswell, G.J. Royal Air Force flight trials of positive pressure breathing. *In* Proceedings of a Symposium on High G and High G Protection, Aeromedical, and Operational Aspects, pp 62-71. Royal Aeronautical Society, London, 1987.
 14. Henry, J.P. A determination of the mechanical limits to severe pressurisation of the mammalian lung. Committee on Aviation Medicine Report No 483. National Research Council, Washington, DC, 1945.
 15. Jennings, J. and Zenetti, C. Positive pressure breathing as a G-protection device: Safety concerns. *SAFE Journal*. 18(1): 52-57, 1988.
 16. Leverett, S.D., Burton, R.R., Crossley, R.J., Michaelson, E.D. and Shubrooks, S.J. Physiologic responses to high sustained +Gz acceleration. USAF School of Aerospace Medicine, SAM-TR-73-21, 1973.
 17. Pluta, J.C. LOC survey. *Flying Safety*. 1984; 25-28.
 18. Prior, A.R.J. Centrifuge assessment of the +Gz acceleration protection afforded by full coverage anti-G trousers. 60th Annual Scientific Meeting, Aerospace Medical Association. Washington D.C. 1989.
 19. Prior, A.R.J. The development of a system of enhanced G protection for aircrew of agile aircraft. PhD thesis, University of London, 1991.
 20. Shaffstall, R.M. and Burton, R.R. Evaluation of assisted positive pressure breathing on +Gz tolerance. *In* Preprints of Ann Aerosp Med Assoc, pp 80-81, 1977. (Full report: *Aviat Space Environ Med* 50:820-824, 1979).
 21. Shubrooks, S.J., Jr. Positive pressure breathing as a protective technique during +Gz acceleration. *J Appl Physiol* 35:294-298, 1973.
 22. Sieker, H.O., Martin, E.E, Gauer, O.H. and Henry, J.P. A comparative study of two experimental pneumatic anti-G suits and the standard USAF G-4A anti-G suit. Wright Air Development Center, WADC-TR-52-317, 1953.
 23. Wood, E.H. and Lambert, E.H. Some factors which influence the protection afforded by pneumatic anti-g suits. *J Aviat Med* 23: 218-228, 1952.
-

INCREASE OF HIGH-SUSTAINED $+G_z$ TOLERANCE AT THE EXPENSE OF PILOT'S WORKING POSTURE CHANGE

Stupakov G.P., Khomenko M.N.

Air Force Institute of Aviation and Space Medicine
 Petrovsko – Razumosvskaja Avenue 12
 Moscow A-83
 Russia 125083

Abstract

Lecture summarizes practical experience and results of theoretical investigations in the field of anti- G_z protection of flyer in high performance fighter-aircraft.

There have been examined the physiological and ergonomical issues of implementation in aerospace flying practice of the anti-G variable geometry seat, which are aimed at the prophylaxy of adverse effects of high sustained, rapid onset rate longitudinal ($+G_z$), lateral (G_y) and combined (G_z/G_y) accelerations.

There have been presented the results of estimation of protective efficiency for variable geometry seat, received at multiple centrifuge testings, as well as its advantages with reference to prolonged flights, which were discovered in ground flight simulator experiments.

There have been elucidated the main physiological particularities of effects of lateral G_y and combined (G_z/G_y) aerial combat maneuvering accelerations. There is verified the applicability of variable geometry reclining seat for prevention of some deleterious effects of hypergravitation of flyer's organism.

Significant role is shared to physiologo-hygienic aspects of flyer's articulate seat in context with arrangement scheme for flight cabin workstation in high performant fighter aircraft.

* * *

The aerial combat $+G_z$ -accelerations, acting on military flyer onboard of last generation fighter-aircrafts, are characterized not only by high peaks, but also by rapid onset rate as well as by extended duration. At such adverse conditions pilot may suffer from serious functional incapacitation up to loss of consciousness, in some cases — without any precursors in form of "gray-or blackout". As it is well known, emergence of unforeseeable loss of consciousness under exposure of high maneuverable aircraft control evolutions was the cause of some flying accidents.

So as to gain the flyer's tolerance to intense and powerful $+G_z$ -stresses, generated during high performant and energetic control of modern fighter-aircrafts, at present there have been used and developed various physiological procedures: selection of pilot personnel with especially high $+G_z$ -acceleration endurance centrifuge training, efficient rehearsal and sophistication of protective anti-G straining physical skills, general and special physical preparation of flying staff and so on. On a line with this, major attention in achievement of high $+G_z$ -tolerance levels has been shared to implementation, improvement and further development of physical means and ways of counter- $+G_z$ -protection.

However, the majority of aerospace medical specialists are biased to think, that the resources of $+G_z$ -acceleration tolerance enhancement at the cost of further adjustment and conditioning of traditionally used methods and practices in pilots to some extent are near to exhaustion.

In these circumstances there has been observed relatively reascent interest and urgency to implementation in fighter-aircraft cabins of special counter $+G_z$ -stress seats, which change the working posture of military flyer in reference to $+G_z$ -acceleration vector.

The initial theoretical premises to construction and design of such seats are following. In order to support the brain circulation, the most important thing is diminishment of aorto-retinal hydrostatic column height. So, any way and manner, which lead to reduction of the distance on a vertical line between heart and brain, will be efficient procedure to maintain vision and consciousness in flyer, submitted to high level $+G_z$ -accelerations.

This task may be solved by change of flyer's working posture in aircraft cockpit.

It is common knowledge, that during World War II some English and German fighter pilots before to start aircraft maneuvering with high $+G_z$ -level of accelerations have had bent forward and occupied the specific stance of "writhed" position. To alleviate to flyer the such posture occupation in some aircraft cockpits the aviation technicians have had raised a little the

control pedals up to 15 cm higher above their standard position. But heightened rate of spinal column traumas in that posture forced the flyers to give up such anti-G protective procedure.

Later, as a result of special investigations, it was acknowledged more rational and adequate the backward deflection of flyer's body in reference to acting $+G_z$ -acceleration vector at some angle. There was established, that the climbing of anti-G working posture protective efficiency has progressing character at deviation of body's longitudinal axis on angle more than 45° (Figure 1).

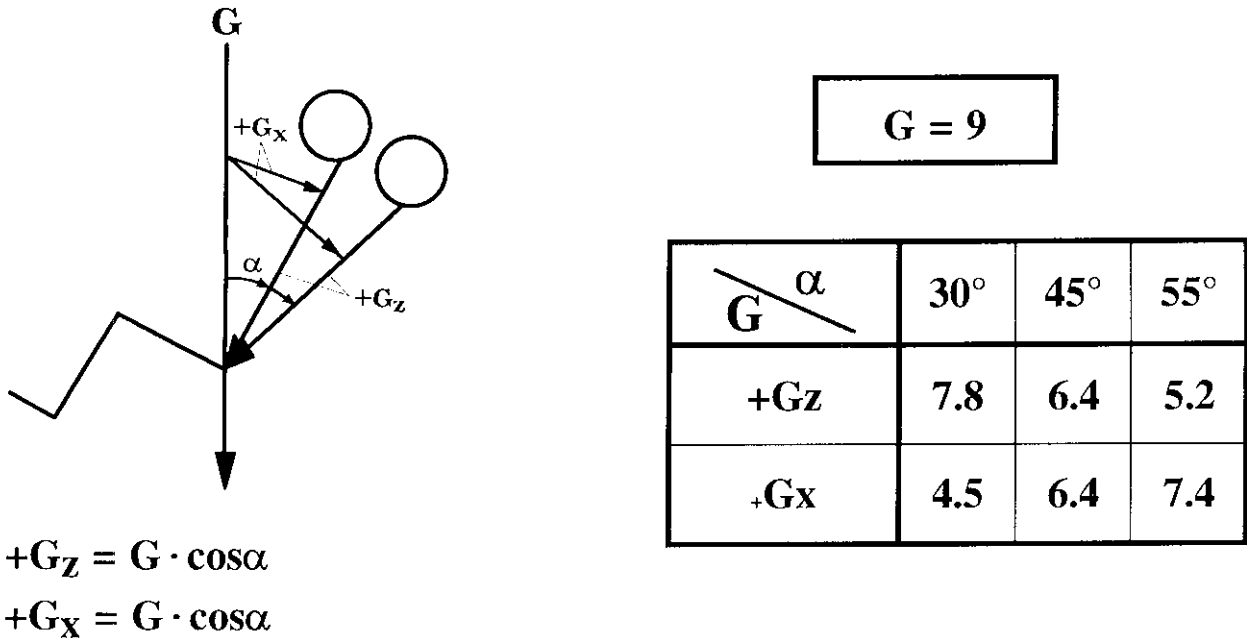

Fig. 1. Anti-G protective efficiency of seatback supination angles

This particularity may be theoretically explained, if one takes into consideration, that during flyer's torso supination the change of longitudinal constituent of acting on his body acceleration may be presented in form of trigonometric function $\cos\alpha$.

So, provided, that aorto-retinal angle (approximately equal $\approx 15^\circ$) and backseat supination changes from 30° up to 45° , we have come to conclusion, that absolute value of $\cos\alpha$ alters by 1,8 times less than at augmentation of above mentioned angle from 45° to 55° .

Rising the body longitudinal axis supination angle in reference to $+G_z$ -acceleration vector may serve as rather efficient way of counter- $+G_z$ -acceleration protection. But it should be kept in mind, that during $+G_z$ -acceleration vector angular co-ordinates modification, apart from hemodynamic effects, it is necessary to consider also other biomechanic reactions, the specific importance of which might significantly change with transfer from longitudinal $+G_z$ -accelerations to transverse $+G_x$ -ones (Figure 2).

As may be seen from drawing on Fig. 2, the main biomechanic feature of body position in deviation of its longitudinal axis by 45° from acting acceleration vector consists of equality between longitudinal and transverse components, which explains the particular traits of physiological criteria of tolerance to accelerations in such conditions. That is precisely, alongside with visual disturbances in equal expansion of inertial forces the limiting role begin to acquire the factors of transverse constituent of acceleration — breathing discomfort. With supine deviation of longitudinal body axis by 55° , there is decreased inertial pooling of blood in lower body and extremities, on one hand, and significantly arises the probability of breathing distresses.

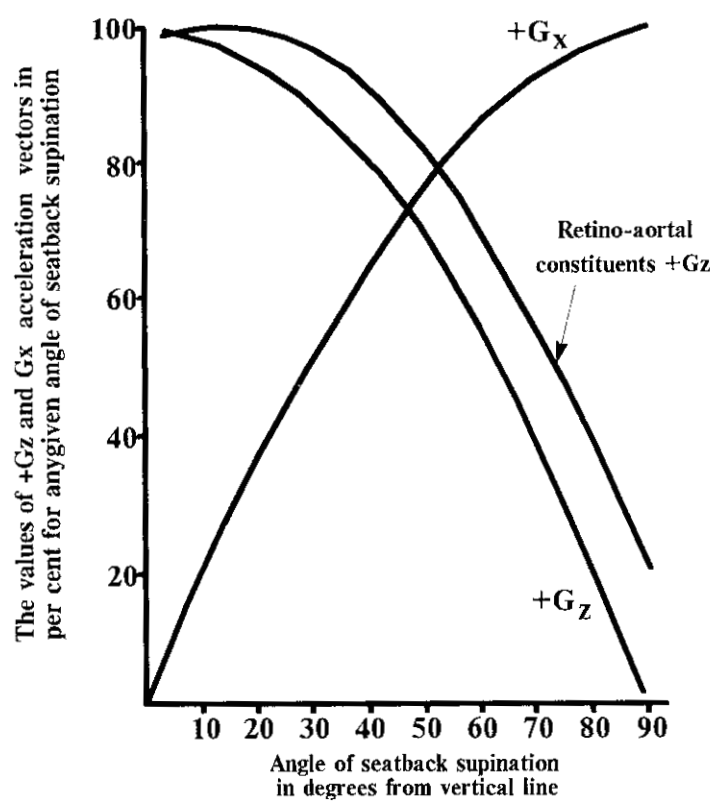

Fig. 2. The values of +G_z - and - G_x acceleration vectors in per cent for any given angle of seatback supination.

In investigations, made by our Institute research workers Bondarenko R.A. and Tikhonov M.A., there were detailed the specific relationships of physiologic mechanisms interaction in combined application of various anti-G means and devices: anti-G suit inflation, positive pressure breathing, augmentation of supination angle of backseat. The authors have noted, that in augmentation of longitudinal body axis supination angle from vector of acting +G_z-acceleration it is necessary to decrease the inflation pressure of anti-G suit in lower body region (Figure 3), but at the same time for compensation of growing transverse gravitational load on breast and

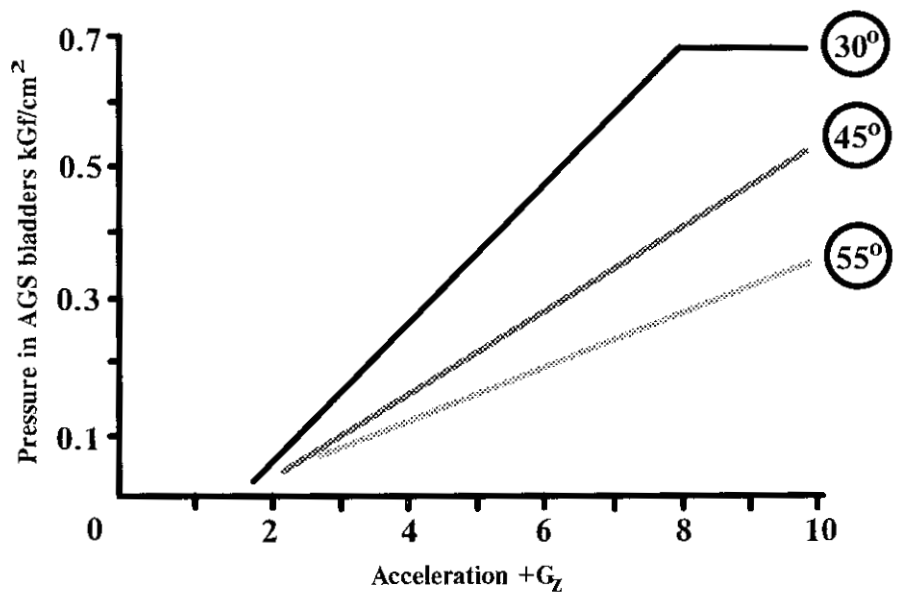

Fig. 3. Pressure regimens in AGS bladders in dependence on angle of seatback supination

belly areas there emerges the need to increase the level of positive pressure breathing up to 60 mm Hg. In turn, the positive pressure in breathing system, provoking the systemic increase of arterial blood pressure, shifts the boundary of thigh and leg arterial vasa occlusion, generated by positive pressure on lower body, increasing simultaneously the possibility of inertial blood depot filling in lower limbs.

Considering, that augmentation of backseat supination angle must be coupled with alteration of pressure regimen in bladders of anti-G suit and oxygen breathing system, the technical solution of this problem means the development of adaptive multi-regimen anti-G suit automated pressure regulator and oxygen breathing apparatus.

The other way of anti-G protection on a base of posture changes is a use of elevated thigh position (Fig. 4). In such posture there is decreased pooling of liquid phases in lower body which conduces to conservation of circulating blood volume and ergo might raise the tolerance in humans to action of $+G_z$ -accelerations.

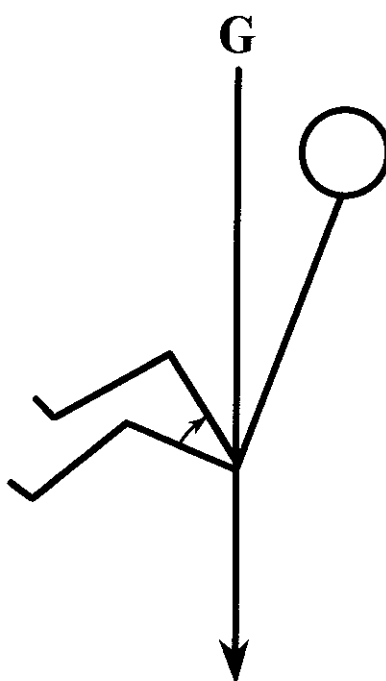

Fig. 4. Anti-G protective efficiency of thighs' elevated position

As a result of specially performed experimentations, directed for determination of flyer's optimal posture under exposure of $+G_z$ -stress, there was established, that there is a need in a strict observation and maintenance of alignment between supination angle of backseat and head support angle in reference to $+G_z$ -acceleration vector, as well as thighs and tibia in relation to body torso.

In relation to this in Russia sub specie to implementation on prospective fighter — aircrafts was developed and successfully tested in static conditions and dynamic exposures of $+G_z$ -accelerations on centrifuge the experimental model of variable geometry ejection seat. In standard position the seat has a backseat supination angle equal to 23° (seat bowl angle — 13°), and during reclining transformation under action of $+G_z$ -accelerations the angle of backseat supination extends up to 48° (seat bowl — 10°) (Fig. 5). Considering the aircraft's angle of attack, the angle of reclining of longitudinal body axis in reference to direction of acting $+G_z$ -accelerations resumes correspondingly the approximate values at 30° and 55° .

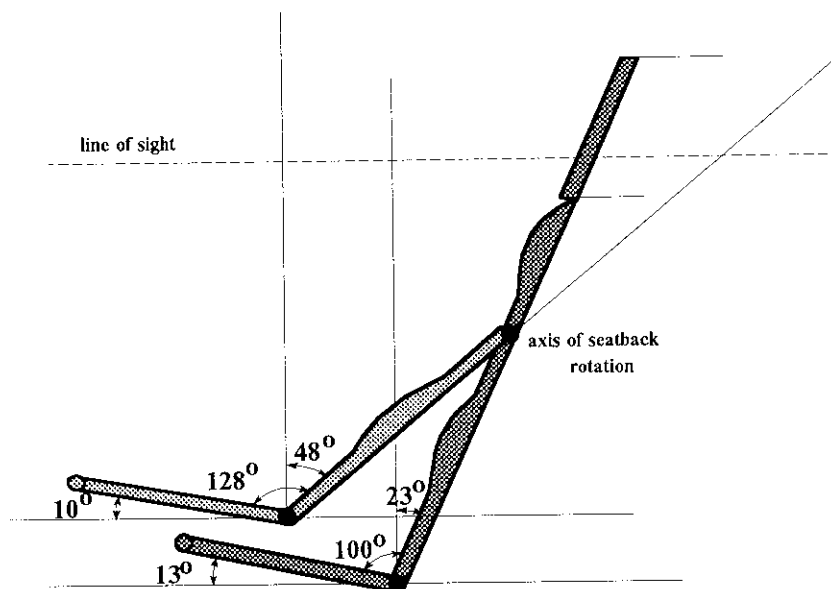

Fig. 5. Scheme of supination of variable geometry seat

The use of articulating variable geometry pilot seat, anti-G suit and positive pressure breathing system warrants to trained flyer the efficient protection against high-sustained $+G_z$ -acceleration levels (Fig. 6).

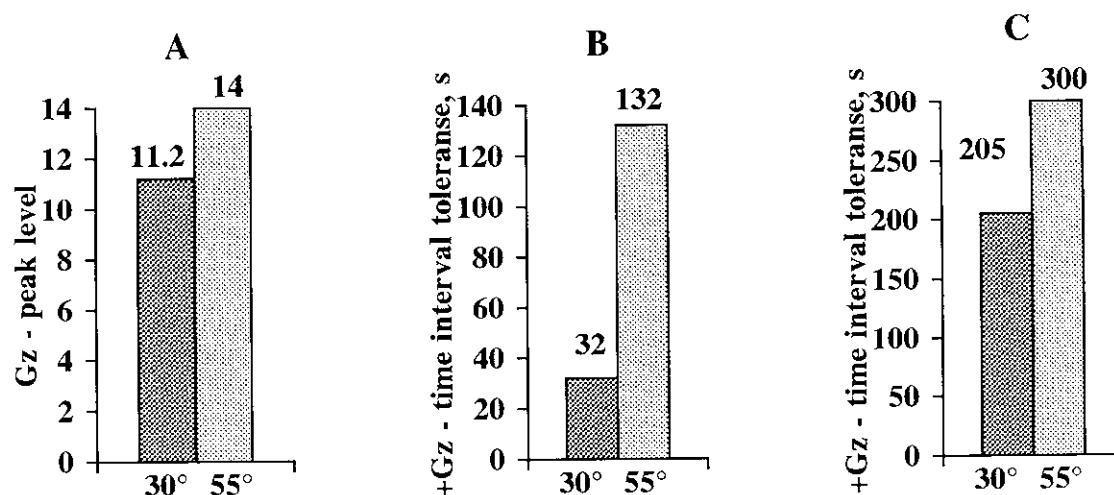

Fig. 6. Efficiency of seatback supination angle in positive pressure breath and AGS inflation

- A) Maximum tolerable $+G_z$ - level with onset rate 0.1 G/S;
- B) Maximum time duration limit of $+10.0 G_z$ tolerance;
- C) Maximum time duration limit of air combat maneuvering profile $+G_z$ - tolerance from $+5.0$ to $+9.0 G_z$

As can be seen from graphic data on Figure 6, the increase of backseat supination angle in articulating chair from 30° to 55° , combined with above cited additional protective means leads to enhancement of $+G_z$ -acceleration tolerance more, than 3,8 G. The total time duration of $+10 G_z$ -acceleration endurance augments more than 4 times, and tolerance to complex ACM profile of $+G_z$ -accelerations from $+5,0$ to $+9,0 G_z$ more than 1,5 times. The magnification of seatback supination angle up to 55° also significantly reduces the degree of physical fatigue and marked-

ness of organism's physiological reactions to submission of high-sustained $+G_z$ -acceleration levels (Fig. 7).

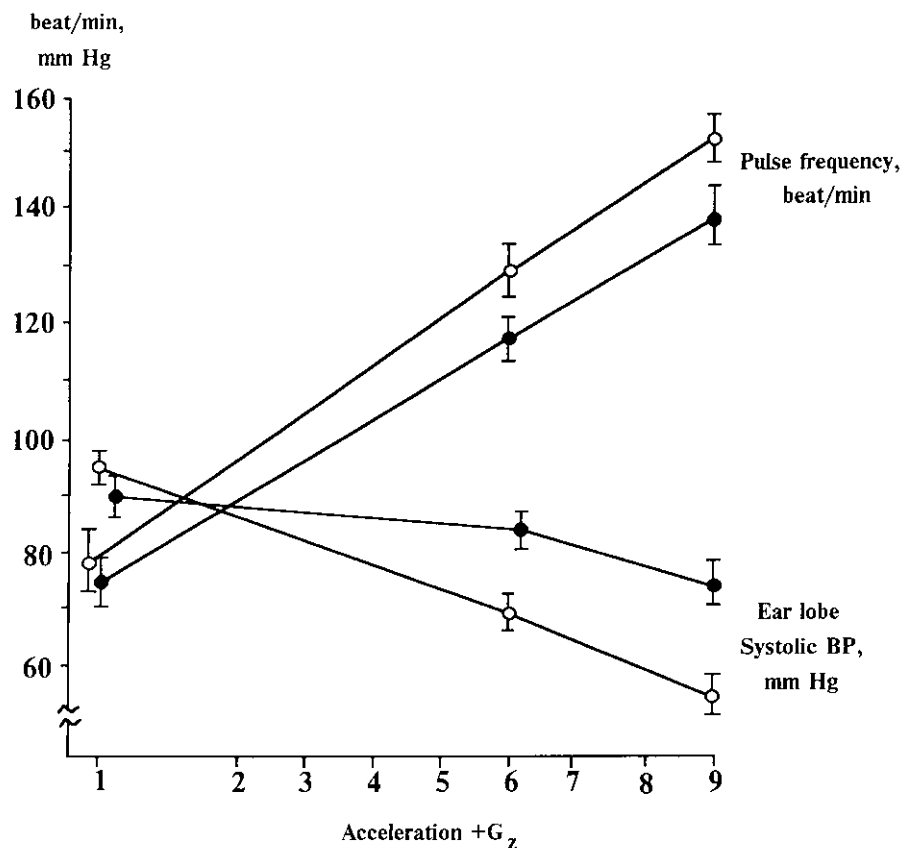

Fig. 7. Dynamics of pulse frequency and systolic blood pressure in vascular bed of ear lobe of test-subjects in variable geometry seat under inflation of anti-G suit and positive pressure breathing during $+G_z$ - acceleration exposure with onset rate 0.1 G/S

- - angle of seatback supination - 30°
- - angle of seatback supination - 55°

The work in variable geometry seat diminished the risk of occurrence of some prognostically unfavorable remote health effects due to repeated systemic exposures $+G_z$ -accelerations, such as sequelae of pelvic vasa lesions, deformation of bicuspid and tricuspid mitral valves, traumatic injuries of vertebral end-plates and ligamentary apparatus of spinal column.

Therefore, the alteration of working posture of flyer by enhancement of backseat supination angle, thighs elevation is an efficient way to increase the tolerance of flyer to $+G_z$, and corresponding technical solutions look very attractive and prospective.

But there exist some other aspects of flyer's posture change, which enable to increase its endurance to air combat maneuvering accelerations.

In example, performance of aerobatic evolutions and stunt flying on prospective fighter-aircrafts may be accompanied with action of side lateral accelerations (G_y) as well as combined effects of accelerations (G_z/G_y), where the significant role plays the acceleration vector. The peak of tolerable lateral accelerations is approximately 4 G lower in comparison with longitudinal $+G_z$ -acceleration one (Fig. 8). The time limit of tolerable combined action $+G_z/G_y$ acceleration has declined, when the value of constituent acceleration $+G_z$ exceeds 5G, and G_y — 2G (Fig. 9).

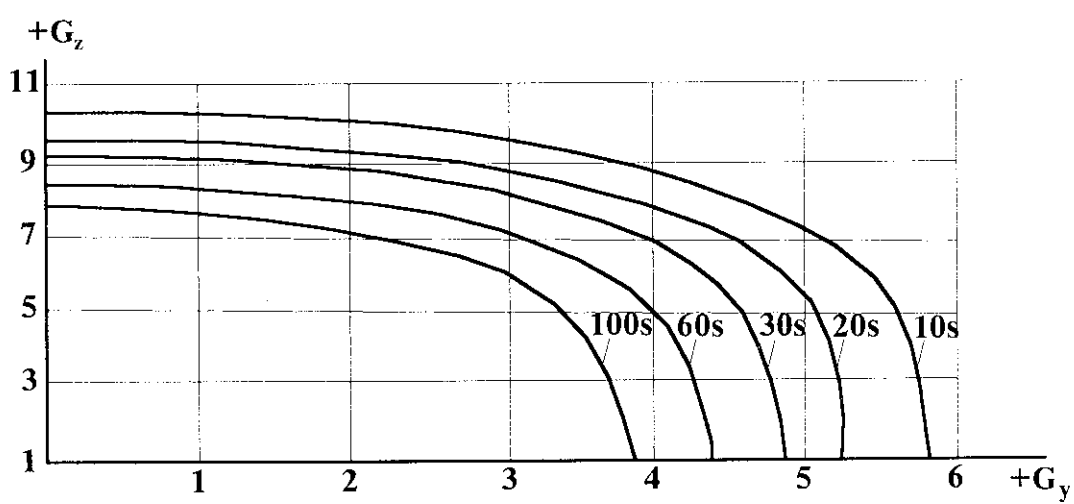

Fig. 8. Dependence of maximum tolerable values of +Gz and +Gy on their alignment and duration of action.

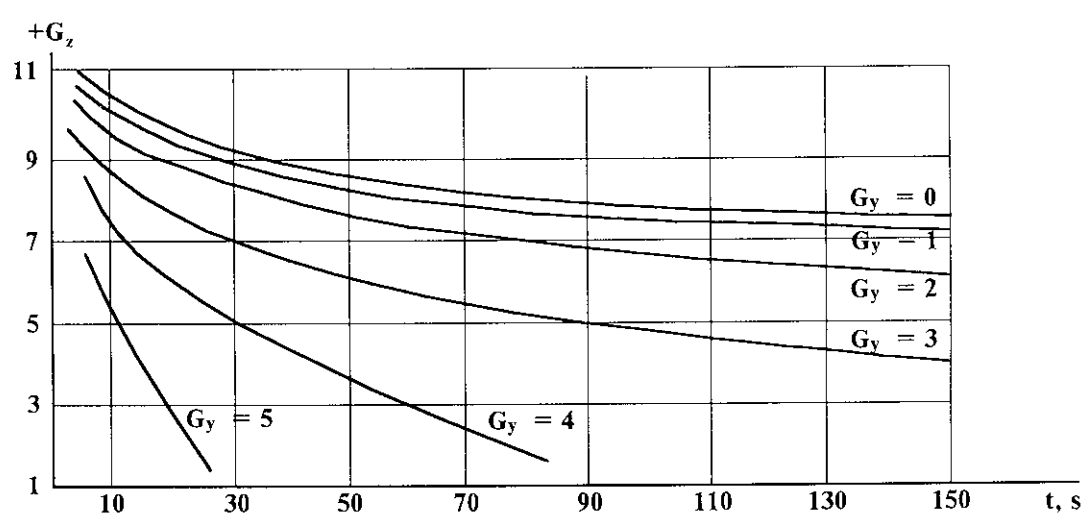

Fig. 9. Dependence of maximum tolerable duration time under combined exposure of +Gz/+Gy on value of +Gy - acceleration.

The main causes, limiting the flyer's tolerance under exposure of lateral, as well as combined accelerations, are blunt deviation of head and torso in direction of acceleration vector, important tiredness of posture supporting muscles, significant disorganization of working posture and painful sensations in forearm and cubital joint areas.

The cardio-vascular system reacts to the effects of combined accelerations G_z/G_y with increase of lateral acceleration constituent by heightened pulse rate and diminished stroke volume and cardiac output.

Breathing rate under combined action of $+G_z/G_y = 5,0/3,0$ accelerations is approximately 25%, while pulmonary ventilation 50% higher in comparison with same parameters, observed during exposure of longitudinal $+5,0 G_z$ -acceleration. To some extent there are rising the indices, characterizing the physiological cost of withstood subjection. Exempli gratia, under $1,0 G_y$ exposure the value of oxygen debt corresponds to level, which is registered under effect of $5,0 G_z$ -acceleration. In accordance with this trend under submission of lateral accelerations the pulmonary diffusion — perfusion processes are disturbed in much greater degree, than in action of

longitudinal accelerations, which is stipulated by shift of mediastinum, compression of pulmonary lobes, ebbing of alveolar ventilation and gaining of physiological pulmonary by-pass.

The lateral acceleration reveals extremely negative effects on pilot's performance: the equal probability of mission failure has been observed at much lesser peaks of $+G_z$ -accelerations, than $+G_z$, including the cases of combined exposures.

According to data, published by J.Frazier et al. (1982), under effect of $5,0 G_z$ -acceleration the quality of steering activity of flyer has been deteriorated only by 19% in contrast to static condition, while in experimental runs with combined exposure of $+5,0 G_z$ and $+1,0 G_y$ -accelerations this index plummeted by 45% and under $+5,0 G_z$ and $+2,0 G_y$ — even more by 70%.

It should be also stressed, that under combined action of accelerations there rises the probability of illusory spatial attitude perception.

The above noted phenomena of influence on organism of lateral and combined accelerations clearly suggest the necessity of development of prophylactic capabilities to cope their adverse and deleterious effects.

Successfully approbated and tested in experimental conditions seat of variable geometry with specially adjusted restraint and fixation system and side arm stick engine and plane controllers might be recommended as efficient way of protection of flyer against not only longitudinal, but lateral and combined accelerations too.

There was established, that in comparison with serially manufactured ejection seat of type K-36 DM with enhancement of seatback supination angle in reclining seat from 30° to 55° there occurs an extension of tolerance to combined action of $+G_z/G_y$ acceleration in average by 2-3 G and improves the efficiency of human operator performance approximately 2,5 times.

However, the augmentation of articulated seatback supination angles with corresponding body support surfaces has challenged a set of serious physiologic-ergonomic problems: there are sharply reduced the conditions of aircraft control organs accessibility and the scope of view for information-controlling field with in-cabin displays and instruments panels.

Disturbance of flyer's accessibility to reach engine throttle, control stick and some other organs is due mainly to backward departing of the brachial point and pedals — with upward removal of knee joint point. Bothered view of flight display panel is related to upward shift of pilot's line of sight. On account of this considerable part of display panel is dislocated from the zone of optimal visual performance, which is found in limits $\pm 15^\circ$ from standard position of sight line. When flyer's head leans on a headgear of seatback, the comfort zone of visual performance embraces only collimator and head-up display. For adequate perception of instrumental information pilot needs to refocus his visual axes and to incline his head in downward position, which in turn leads to additional straining of eye and neck muscles and in prolonged flight missions this may provoke premature muscular debilitation and lower pilot's work capability.

Therefore the augmentation of body support surfaces inclination angles in articulate seat demands not only the recalculation of accessibility zones for engine throttle, control stick, pedals or replacement of traditional plane's control stick by side-arm controller, but research and development of new arrangement schemes for onboard and instrument panels in aircraft cockpit. It should be emphasized, that the optimal sector for making-up of avionics indicators with consideration of their view conditions is located at upper part of instrument panel.

The results of conducted investigations have led to conclusion, that in formation of arrangement scheme for seat with augmented angles of body-supportive surfaces inclination it is necessary to ensure their optimal correlation with each other and optimal mutual allocation with engine throttle, control stick, pedals.

So, it should be noted, that position of pilot eyes' visual axes depends not only on back-seat supination angle, but this angle in itself plays certain role in formation of position of eyes' visual axes in comfortable working posture.

Important significance in change of seatback supination angle has a maintenance of some optimal angle in hip joint, the value of which lays in rather narrow range — from 100° up to 107° .

Especially important role for formation of flyer's working posture in reclining seat with augmented angles of supination of body surface supporting seatback belongs to a solution of optimal allocation between seat's headgear and spinal part of seatback.

The optimal position of flyer's head while fixating the eyes on point of instrumental board, located at eye level and determined on angle between horizontal collimator line of sight and eye-aural line, is characterized by values, which spread rather wide band. At vertical position of seatback the comfortable position of flyer's head is set by average value of 17° , and individual dispersion comes to average from 6° to 32° upward from horizontal line. In case of further seatback supination angle augmentation this value grows non-significantly, and at 55° supination angle reaches some average 26° (with individual dispersion from 12° up to 43°). These data suggest the necessity of taking into consideration the most frequently read by pilot indicators in the area of optimal visual performance, that is, not lower, than 15° from line of flyer's visual regards. So, for flyer being in a seat with seatback supination angle 30° , the most sampled indicators and displayed must be located not lower than 8° from collimator line of sight.

The profiled curvature of upper thoracic and neck parts of spinal column has its own referenced anthropometric point — the maximum promontory on perpendicular to seatback's plane (neck point — Fig. 10). During augmentation of seatback supination angle in seat from 0 to 55° the average value of neck point promontory changes insignificantly (from 100 to 150 mm), but individual variation is rather large: from 55—200 mm at 0° angle of seatback supination up to 75—220 mm — at 55° of the same parameter. This yields to the notion, that it is impossible to design strictly "unified", non-regulated profile of neck-brachial part of seatback, ignoring the seatback supination angles at all, because such construction will be awkward for predominant population of flyers.

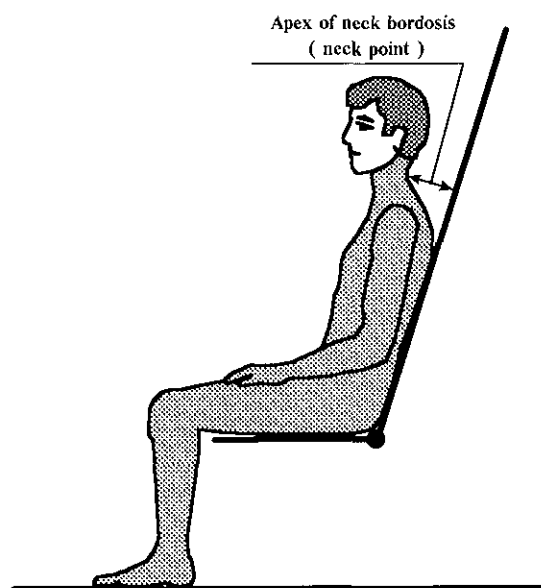

Fig. 10. Position of apex of neck bordosis (neck point).

An exemplary configuration of neck-brachial cradle for variable geometry seat and the limits of individual adjustment of such support assembly are presented in Fig. 11. The above indicated configuration of cradle enabled to build it on type of movable brachial support, fixed to backseat in point of rotation, which is situated 150—200 mm lower relatively to projection of neck point on backseat. Such technical solution allowed to decrease the risk of ejection escape trauma thanks to preliminary "pressing" of cradle and rear headgear toward backseat on safe value.

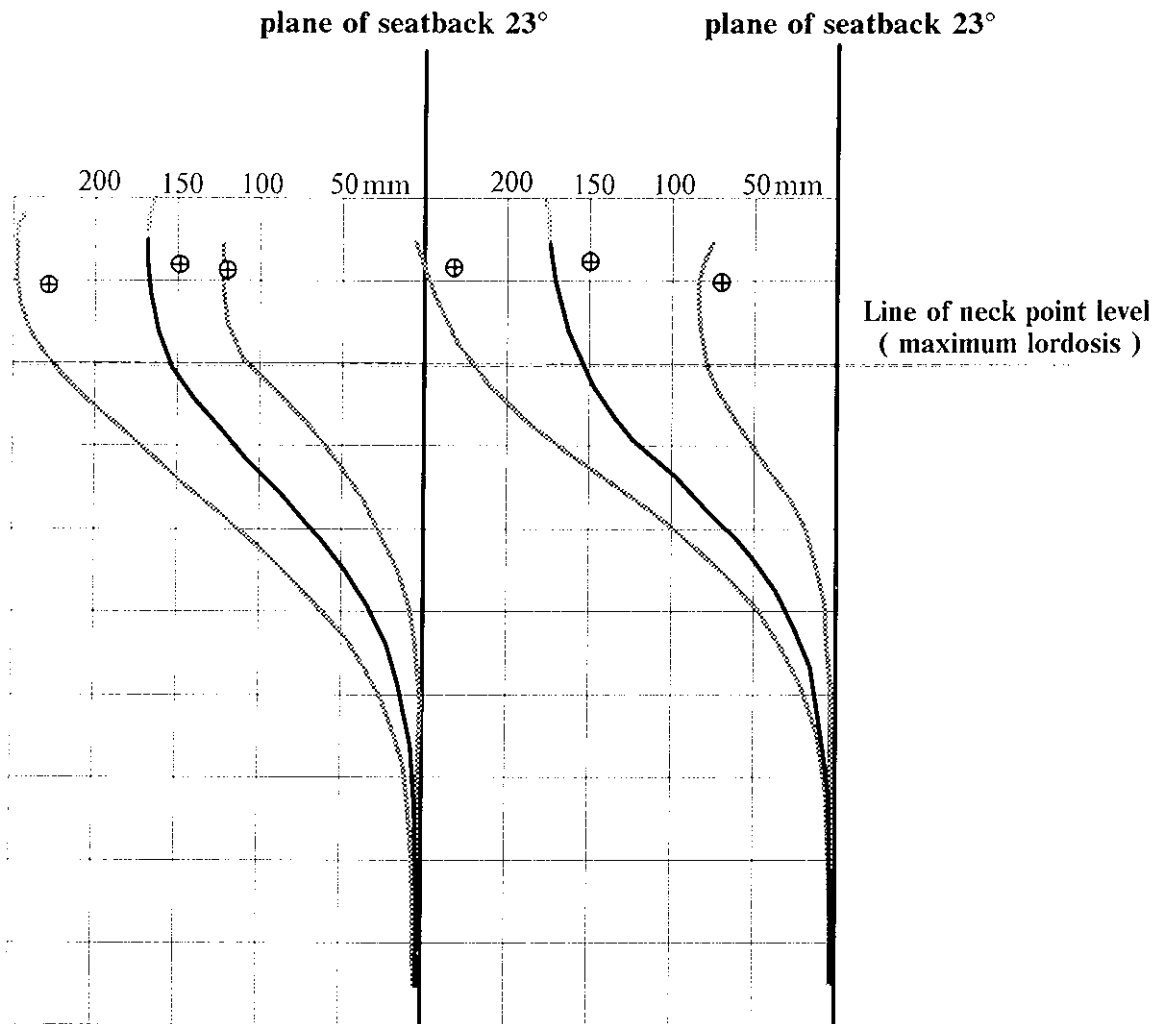

Fig. 11. Transverse profile of collar-shoulder bed cradle corresponding to anatomophysiological curvatures of spinal column in optimal conditions of line sight position

- - mean value;
- ⋯ - minimum and maximum values;
- ⊕ - occipital point.

Vertical adjustment of configured bed (on a maximum promontory — neck point) in reference to backseat demands significantly lesser limits: $\pm 50-60$ mm, which probably, made possible to restrict in a seat construction by only perpendicular "out-of-backseat" adjustment of mobile cradle element to ensure the flyer a comfortable posture with corresponding anatomophysiological curvature of upper-thoracic and neck parts of spinal column.

Starting from anthropometric characteristics of head and their alignment with coordinated of neck point, the occipital point (or point of contact with headgear) will be stationed 50—60 mm higher the neck point, and the limits of individual adjustment of headgear will in fact coincide with such at adjustment of cradle element.

According to prognostic estimations and expectations of specialists in 90-ies there will occur the real possibility to overcome the existing technical and physiologo-ergonomic limitations in implementation of variable geometry seats in agile aircraft fighter cockpits.

Striving to prevent the deterioration of sight levels in pick-ups of in-cabin panel display and instrument indication information, as well as reachability of control stick, engine throttle and some other control devices, which are traditionally placed in forward hemisphere of cockpit, the

arrangement scheme of variable geometry seat is made in such way, that during transformation of seat from seatback supination angle position at 23° to configuration with 48° of one, there practically does not occur the displacement of brachial point and eyes' visual axes. Despite this, the installation in aircraft cabin of variable geometry seat demands mandatory use of side-arm aircraft and engine throttle controllers, as well as pedals, which must ensue the transfiguration of seat in order to guarantee the maintenance of optimal zones of accessibility, while manipulating with them.

As a result of investigations, made in static conditions and under exposure of $+G_z$ -accelerations, there were determined the arrangement characteristics of side-arm aircraft stick controller and pedals (Fig. 12).

It should be stressed, that at installation of side-arm stick controller on height 250 mm above seat-referenced point "S" in conditions of high $+G_z$ -acceleration, exceeding 7,0 G, some test-subjects revealed and suffered from the painful sensations in muscles and petechial hemorrhages in skin of forearms, though in static conditions such arrangement of side-arm stick controller was quite agreeable. In this relation the arrangement characteristics of variable geometry seat under exposure of high $+G_z$ -accelerative forces need closer definition. This leads also to necessity of further improvement of existing anti-G garment and devices to bar unfavorable hydrostatic effects in forearm vessels.

It should be emphasized, that use of variable geometry seats makes possible not only to heighten the tolerance of flyer to high $+G_z$ -accelerations, but also significantly to improve the ergonomic environment for his controlling activity, especially in prolonged flying missions.

As data, received in our experiments, suggest, in case of application of mass-produced ejection seat with reestablished seatback supination angle at 17° the time limit of comfortable duration of flyer in it amounts 2—2,5 hours while in use of variable geometry seat with back-seat supination angle at 30° this parameter protracts up to 7 hours and at position 55° — even greater — 10 hours.

The periodic change of backseat supination angle in prolonged flying missions is a very efficient procedure to maintain the flyer's performance in demanded condition. It is worthy to note, that owing to redistribution of pressure on flyer's soft tissues, which contact the seat supportive surfaces, there occurs the delay in development of pain syndrome, which plays a leading role in lowering of pilot's functional state and work ability in long-standing duration in ejection seat of conventional configuration.

It is established, that maximum time limit of comfortable duration of flyer in reclining seat, achieved by periodic, as pilot wants, transfiguration of seat from position with seatback supination angle at 30° to one with 55° and vice versa, might extend even up to 16 hours.

However, despite some revealed advantages and assets, related to prospective implementation of variable geometry seats, there exist still some issues and aspects, which need further explorations. In particular, they involve the problems of safe bail out and ejection escape from aircraft as well as some other important things.

Therefore, the use of variable geometry seat in complex with anti-G suit and positive pressure breathing will enable significantly to raise the flyer's counter- $+G_z$ -acceleration protection in combat maneuvering of high performant fighter-aircrafts, which yields the blockade of adverse effects of immediate action of high-sustained $+G_z$ -accelerations on his body, as well as extends the prophylactic protective capabilities against negative sequelae of systemic and repeated $+G_z$ exposures.

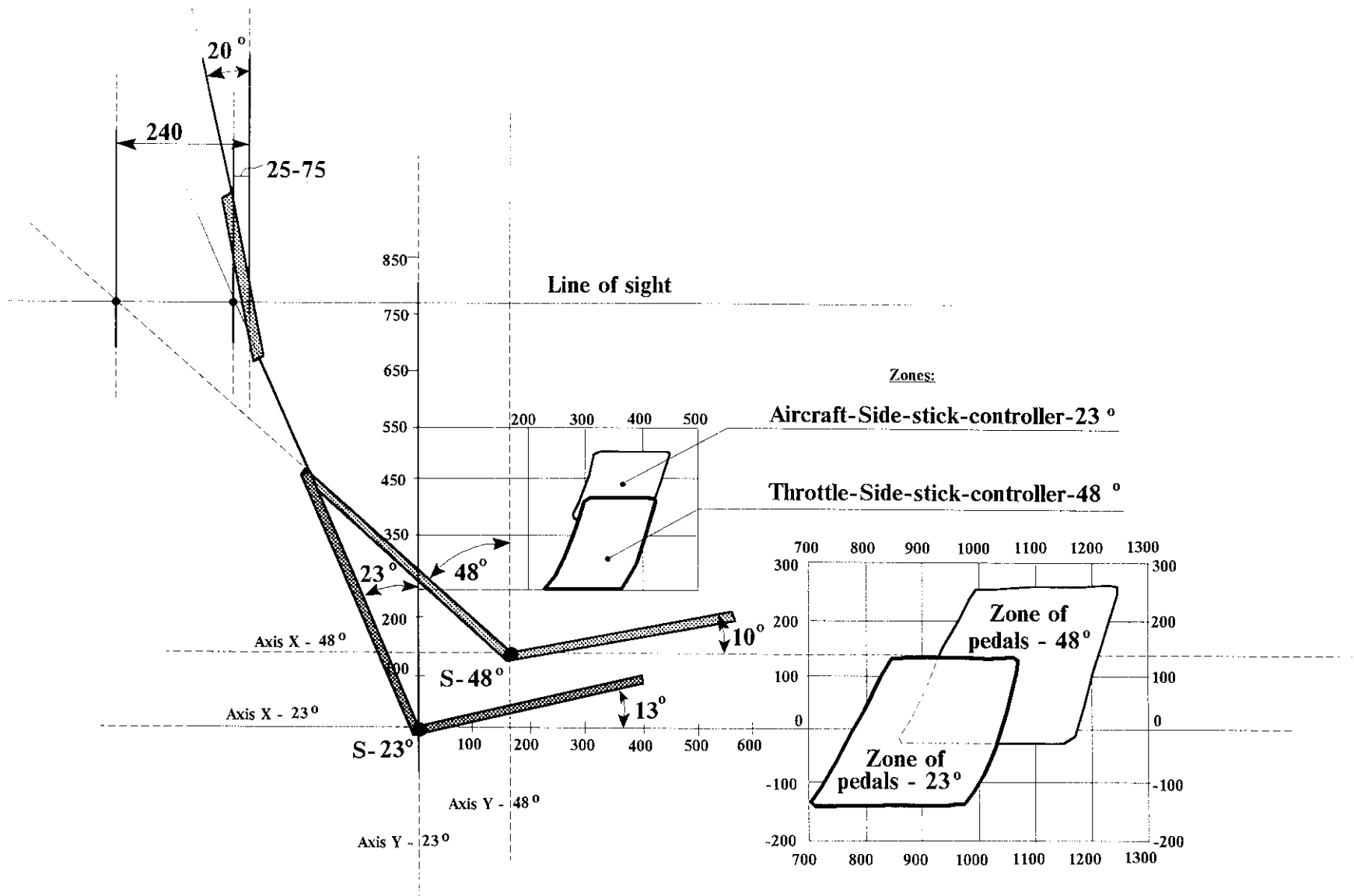

Fig. 12. Arrangement scheme of control organs at installation of changeable geometry seat in aircraft cabin.

NEW ADVANCES IN PHYSIOLOGICAL MEASUREMENTS DURING HIGH-G: TECHNOLOGY

Ulf I. Balldin, M.D., Ph.D.

AL/CFTF

2504 Gillingham Dr. Suite no. 1

Brooks AFB Texas 78235-5104

USA

National Defence Research Establishment, Sweden *

SUMMARY

New non-invasive techniques for measuring cardiovascular parameters have been introduced to the acceleration research in centrifuge and in flight in fighter aircraft. Transcranial Doppler blood flow velocity measurements have been used in the centrifuge to detect brain blood flow changes during high G. As probe movements during high G is a problem, a remote control probe system has been developed and tested for better accuracy. Infrared spectrophotometry has been tested during increased G, but further development is required. Ear opacity blood volume measurements of circulatory endpoints during high G has been re-introduced. The use of Finapres or similar equipment to measure finger blood pressure has shown to be a very effective tool in acceleration research, both in the centrifuge and in flight, when used properly. Impedance plethysmography has also shown to be a useful tool in acceleration research. Doppler ultrasound blood flow measurements and echocardiography are difficult to use at high G-level, if not new robotic techniques are developed. Subjective scales for ratings of perceived exertion during testing of G-protecting measures or during centrifuge fatigue studies seem to be valuable tools in acceleration research and may help to avoid the need for maximal tests in the centrifuge and thereby discomfort and injuries.

with venous, arterial and intracardial probes in human subjects during centrifuge exposure is requiring, time-consuming, and necessitates sterile conditions and thorough surveillance of the subjects. A risk of succeeding thrombophlebitis and thrombosis is always existing. As the subject usually is unaccompanied in the centrifuge car during the G-exposures and is only monitored by TV-cameras and voice communication, the safety of the subject during the runs is always of concern. The invasive techniques are, though, more often used in animal centrifuge experiments, e.g. the use of transonic flow probes in the common carotid and internal carotid arteries in baboons and the use of radio labeled microspheres (25, 36, 37).

NON-INVASIVE MEASUREMENTS

Non-invasive ECG, EMG and EEG measurements have successfully been accomplished during increased G-loads for many years. With the introduction of non-invasive measurements of cardiovascular response to increased G-forces in humans, part of the psychological stress can be diminished, there is no need for sterile conditions and the surveillance of the subjects does not have to be so intense. These medically safer, non-invasive techniques are, though, most used during resting conditions, when the probe outside the body easily can be manipulated and moved to the proper position for a good signal.

INTRODUCTION

The use of invasive measurements of intravascular blood flow and blood pressure

* Currently Visiting Scientist, Crew Technology Division, Armstrong Laboratory, Brooks AFB, Texas, USA

PROBLEMS WITH PROBE MOVEMENTS DURING HIGH G

A problem, however, is that many of the non-invasive techniques for cardio-vascular registrations are very sensitive to probe motions during high-G, which may result in the loss of the signal or false values. It is very difficult to move the probe when it is used in a human centrifuge with the subject sitting by himself without immediate access to the probe.

For that reason some of the non-invasive techniques of measuring physiological variables during resting conditions have not been very successful during exposure of subjects to high G-loads in the centrifuge. This is valid for *e.g.* Doppler ultrasound registrations of temporal artery blood flow, although some researchers have been able to successfully use this technique during moderate G-exposures without straining maneuvers (*e.g.* 24). The proper position of the probe is with this type of registration very critical, which has made the use of this technique very difficult or almost impossible during high G-loads with the execution of respiratory and muscle straining maneuvers to increase cerebral blood pressure in the centrifuge.

The connecting lines or optical fibers with laser Doppler registrations of the skin blood flow in the head region may also be very sensitive to movements during increased G-loads. As the temporal artery is an extracranial artery and the face skin flow is also outside the skull, these measurements only represents the vascular blood flow outside the brain at head level and are not necessarily reflecting changes in the brain blood flow. The large fluctuations in the skin flow with time and large variations with temperature cause these measurements to be of very little value for estimating changes in the blood circulation inside the skull at the brain level.

The temporal artery Doppler ultrasound flow meter has also been used in

combination with ECG-related pulse wave delay for +Gz tolerance assessment (19). Similar difficulties to obtain a true signal during high G forces, straining maneuvers and pressure breathing with a breathing mask must also appear with this technique.

Comparable drawbacks must apply to an equipment to measure eye-level blood pressure using the infrared photoelectric volume oscillometric variations with compression cuff and photo detectors above the superficial temporal artery (22). This device has, though, successfully been used up to 6 +Gz.

TRANSCRANIAL DOPPLER

The introduction of transcranial Doppler blood flow velocity registrations (TCD) for measuring brain blood flow with ultrasound (1), in *e.g.* the middle cerebral artery during increased G in the centrifuge, gave new information about the cerebral circulation during these conditions (16, 28, 29, 34). In some cases it has been possible to register the cerebral blood flow velocity changes during G-loads up to 12 G (G. Ossard, personal communication). With this technique it has also been possible to estimate the blood flow to different regions of the brain during increased G. For instance, estimations have been made of the perfusion of the visual cortex in human subjects exposed to increased G-loads in a centrifuge, while registering the blood flow velocity in the posterior cerebral artery using the TCD-technique (28).

A problem with the use of the TCD technique is, also here, the movements of the probe in relation to the underlying blood vessels during high G-loads, especially with simultaneous respiratory and muscular straining maneuvers. As the straining maneuvers are necessary to increase the heart level and cerebral blood pressure for improving the G-tolerance, it is important to make registrations including such maneuvers, when evaluating G-protection techniques.

REMOTE CONTROLLED TCD

A new technique has been developed to move the probe with three different motors, mounted on the helmet (7). Remote control of these motors allows precise tilting and sliding of the probe during G-exposures (see Figure 1). Prior to use of this device a good TCD signal from the middle cerebral artery must roughly be obtained. Thereafter, when the subject have donned the helmet, a more exact probe position may be found with the remote control system. The positions during high G may be mapped on a computer screen for proper repositioning during movements of the probe at recurrent G-exposures. Usually only vertical movements are required during G-loads. A computerized system has also been developed to automatically repositioning the probe to different precalibrated vertical positions during high G-loads (33). With this device, blood flow velocity in the middle cerebral artery can be registered at G-loads up to 9 +Gz with increased accuracy.

INFRARED SPECTROPHOTOMETRY

During many years ear oxymeters have been used in centrifuge experiments to detect slowly developing oxygen desaturation of the blood reaching the ear lobe. Other new devices that has been tested for measuring the cerebral microcirculation is the use noninvasive multiwavelength near infrared spectrophotometry based on the oxidative status of the brain (18, 40). With this method is possible to measure the relative quantities in the brain of hemoglobin, oxygenated hemoglobin, blood volume and oxidative status of cytochrome c oxidase. Reductions have been seen in Hb, blood volume and HbO₂ during G-exposures. However, with this technique several matters have to be considered before further use according to Glaister (18): a needed pressure of the probe to the skin, movements artifacts, weight of the equipment, quantification of the signal output and more experience with the technique is required before it can be used

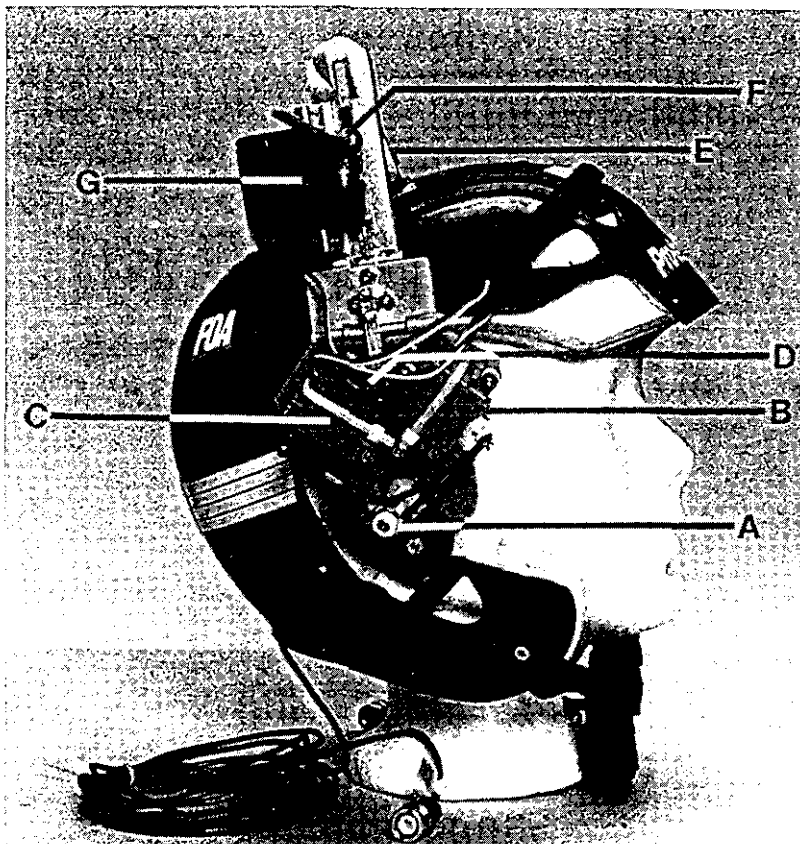

Fig. 1. The helmet with remote controlled probe. A) TCD-probe, B) and C) motors for tilting, D) knob to apply pressure of the probe to the skull, E) knob for gross tilting, F) knob for gross vertical movements, and G) motor for vertical movements of the probe.

From
 SAFE
 JOURNAL
 24 (1) 1994;
 Balldin &
 Werchan (7)

regularly in the centrifuge or aircraft environments.

However, a cerebral oximeter (Somanetics INVOS 3100) using the above described principle has been tested by Bagian et al (3) during graded hypoxia. Correlations have been made to an ordinary pulse oximeter and the cerebral oxygen measurements seemed to follow the general downward trends of arterial oxygen saturation values as measured with the pulse oximeter during desaturation (3). The ability of this cerebral oximeter to measure rapid changes in tissue oxygen saturation makes it a viable candidate for monitoring these changes in the dynamic acceleration environment according to the authors. Further development of this technique seems, however, necessary.

EAR OPACITY MEASUREMENTS

Other equipment for use of objective circulatory end-points to evaluate anti-G suits and respiratory and muscle strain-

ing maneuvers is the reintroduced photoelectrical ear pulse device for registering decrements in arterial pulsation and blood content in the ear (12, 38, 39). This device will be discussed elsewhere in more detail.

FINAPRES

The Finapres monitoring system (Ohmeda model 2300, Madison, WI) using a cuff for the continuous monitoring of finger arterial blood pressure has also been introduced in centrifuge activity. It uses a photoplethysmogram to measure blood volume in a segment of a finger. The fluctuating component of the plethysmogram is related to the arterial blood pressure in the finger and give an accurate measure of the blood pressure (30). The signal acts to alter the pressure in the cuff around the finger, holding the photoplethysmogram steady at a fixed value. The transmural pressure of the finger artery is, thus, kept at zero. In that way changes in the pressure of the cuff

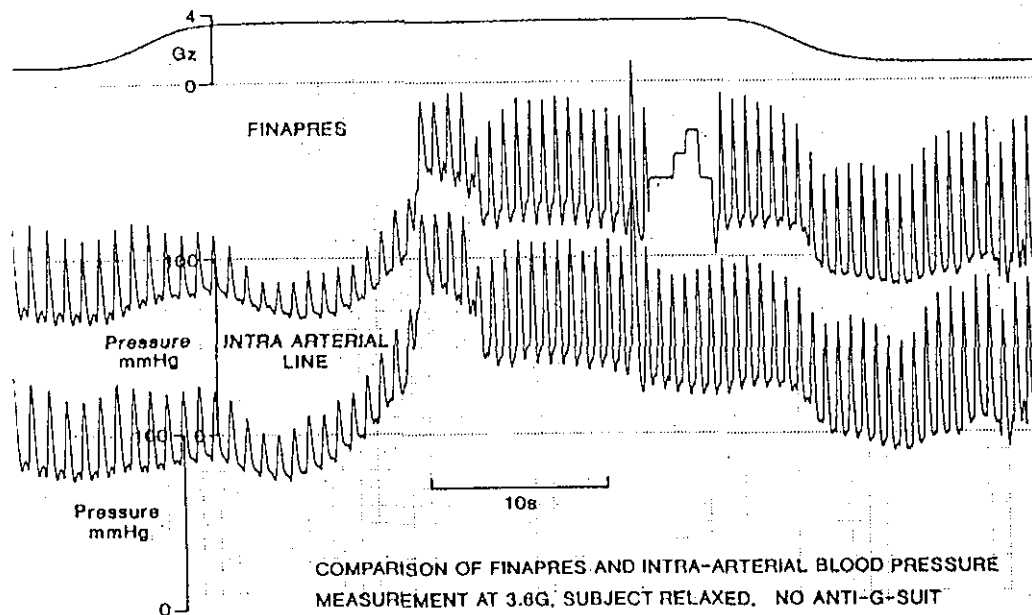

Figure 2. From PROCEEDINGS of the 28th ANNUAL SYMPOSIUM, SAFE ASSOCIATION 1990; I McKenzie (27)

equal the finger artery pressure. The Finapres technique has been validated to invasive measurements during orthostatic stress (20) and Valsalva maneuvers (21).

When used during acceleration in a centrifuge there is a tendency to underestimation of both systolic and diastolic blood pressure with the Finapres compared to intraarterial measurements (27). The systolic finger pressure may be about 12 mmHg lower with the Finapres and the diastolic pressure about 2 mmHg lower according to McKenzie (27), see Figure 2. However, it correlates well with intraarterial line measurements and the slope of the relationship between Finapres and intraarterial values is close to unity.

When using the Finapres during acceleration studies it is important to keep the probe at heart level. During high G the extra hydrostatic liquid column pressure effect is increased by the multiple of the actual G-force. To achieve the eye-level blood pressure a water column may be mounted on the subject's head to reference finger arterial pressure at heart level to eye level. This seems to be preferable to the positioning of the finger at eye-level, due to difficulties to have the Finapres work properly at or close to zero blood pressure, when an internal error checking routine is triggered (27).

It also important to keep the arm so that is supported in a way that prevents local tissue compression in the forearm during centrifuge exposures. Of three different devices used by McKenzie (27), consisting of a gutter supporting the forearm, a thumb suspension system and a padded flat plate supporting the whole arm, the latter performed best.

Still another factor of importance in the use of Finapres is to avoid cooling of the hand by a cool ambient temperature. The signal from the Finapres seems to be very sensitive to the finger temperature with lower temperatures causing vasoconstriction and impaired pulse amplitude registrations (C Lassvik, personal communication). This may be taken care of by, for

instance, a box enclosing the hand with electric heating pads.

With the Finapres technique it has been possible to measure blood pressure changes during centrifuge exposures up to 9 +Gz, even if the signal quite often is lost, at least intermittently, during such high G-loads. A recalibration procedure (which may be shut off) also may disturb the registration.

PORTAPRES IN FLIGHT

A similar but somewhat modified portable blood pressure monitor equipment (Portapres) has successfully been used in flight with a Hunter aircraft in the pilot's personal survival pack at both positive and negative G-loads as reported by Prior et al (31).

IMPEDANCE PLETHYSMOGRAPHY

Another physiological technique that recently has been successfully used in the centrifuge is the tetrapolar impedance plethysmography for measurements of regional blood volume changes in calf, thigh and abdominal segments (32). Passive electrodes are placed over the calf, thigh and abdominal regions and active electrodes on the foot and in the axillary region and conveys a 1 milliamp 50 KHz alternating current. The calculated volumes are expressed as changes from the baseline, with negative values reflecting decreases in volume. The results, using this method, suggest that hydrostatic changes alone during rapid onset +Gz are responsible for an observed decrease in eye-level blood pressure and that increased venous pooling is not a contributing factor to G-LOC in subjects wearing a well fitted anti-G suit.

CARDIAC OUTPUT USING DOPPLER ULTRASOUND

Direct measurements of cardiac output in man has been accomplished during parabolic flights using Doppler ultrasound (35). Measurements have been made on a

continuous basis during 1 G and 2 G and during the microgravity phases of the flight. Cardiac output was estimated using a purpose built Doppler flowmeter that measured the frequency shift, and hence the flow velocity of blood, through the ascending aorta. It used an ultrasound beam that projected vertically down the aorta via the jugular notch. The subjects were examined in seated, standing and supine positions and the cardiac output was recorded at various phases of the parabolic flights. An investigator has done the examination, why it seems difficult to perform these tests at high G in a centrifuge without the use of robotics, which still has to be developed.

ECHOCARDIOGRAPHY

Similar problems will appear with the use of echocardiographic registrations of the heart dimensions and changes during G. Research is currently going on in the centrifuge at Armstrong Laboratory, Brooks AFB, Texas with this technique at lower G-levels with a technician lying beside the subject and performing the investigation (P Celio, personal communication). Even

with this technique, robotic movements of the probe should possibly be of value to avoid the need for a technician in the centrifuge at higher G-levels.

SUBJECTIVE SCALES

Other methods to evaluate the effectiveness of a G-protecting device or procedure are the use of subjective scales for the experience of the effects of the stress. Likert (26) introduced scales for subjective experience of different stresses many years ago. They have successfully been used in centrifuge experiments for assessing the fatigue, comfort, sweating/heat stress and perceived level of G-protection for evaluating different G-protective equipments (cf 4, 23).

PERCEIVED EFFORT LEVEL

It would be operationally and medically advantageous in the research to have submaximal measures of G-tolerance without the need to go all the way to the subjects' maximal endpoint. Recent experience of extensive foot pain, edema and petechiae in a fighter pilot subject

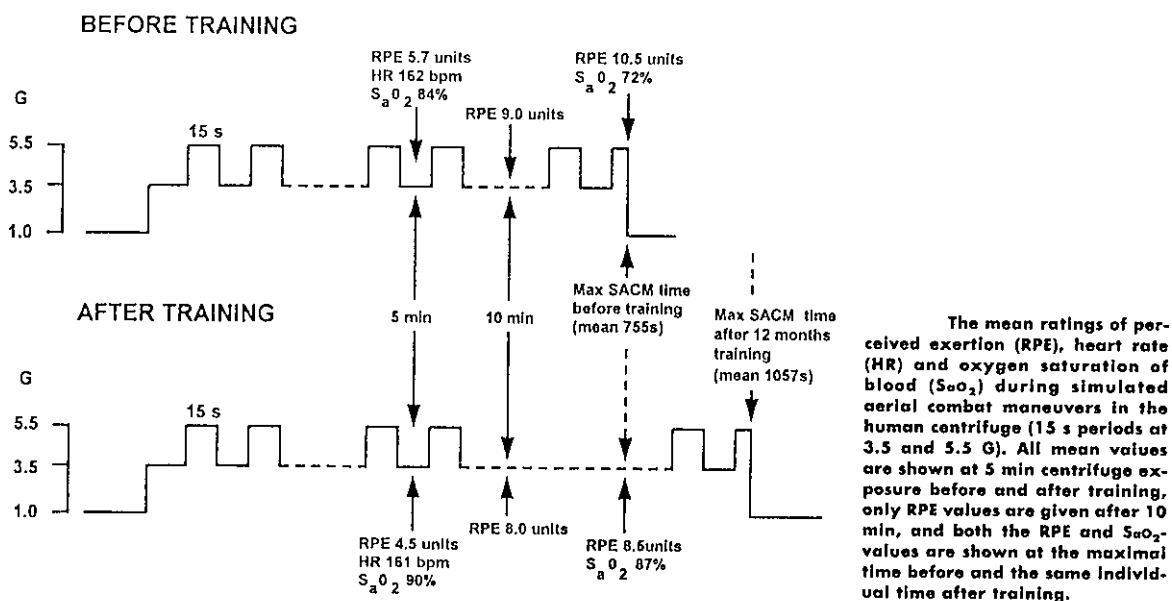

Figure 3. Reproduced with permission from Aviat. Space Environ. Med. Balldin et al. (6).

emphasized this need (5). He succeeded to accomplish 35 9 +Gz peaks (in a simulated aerial combat maneuver centrifuge G-profile consisting of 10 s alternating periods at 5 and 9 G) using extended coverage anti-G suit with pressure breathing during G.

Scales for ratings of perceived exertion developed by Borg (9) has successfully been used during different sports and exercise situations in healthy individuals (10,11,13), during environmental stress-changes in body temperature (8) and ambient pressure (41), during immersion testing of diving equipment (15), during testing of respiratory protective devices

(14) and to assess physical effort during various manual tasks (2,17).

The ratings of perceived exertion scale has also been successfully used in a centrifuge study before and after physical training (6), where it showed a significant difference in RPE values after the training (Figure 3). The technique is now routinely used in centrifuge studies of different G-protective measures or in centrifuge fatigue studies (cf 4, 23). An example of a finding of a non-difference between the use of an anti-G suit system with and without immersion protection in a 5 to 9 G simulated aerial combat maneuver G-profile is shown in Figure 4.

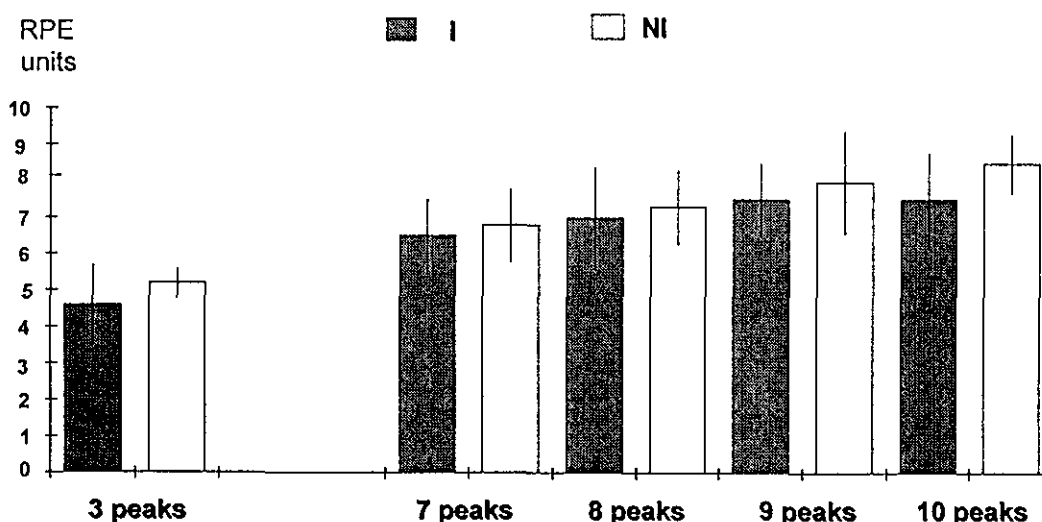

Ratings of perceived exertion (mean RPE-units +/- SD, modified 0-10 Borg scale) after different number of peaks at 9 G in SACM exposure with immersion (I) and nonimmersion (NI) suit. No significant changes were found between I and NI.

Figure 4. From SAFE JOURNAL 24 (3) 1994. Balldin et al. (7).

CONCLUSIONS

New advances in physiological measurements during high G include several non-invasive techniques. The high G environment comprises many difficulties as the subject can not easily be reached in the centrifuge. Remote control of the measuring probe is one solution. Careful use of other equipment allow good registrations

even without immediate availability of the subject. Subjective ratings are still another way to get important physiological information during high G. Further development of suitable techniques is required.

REFERENCES.

1. Aaslid R, Markwalder T-M, Nornes H. Non-invasive transcranial Doppler ultrasound recording of flow velocity in basal cerebral arteries. *J. Neurosurg* 1982; 57:769-774.
2. Asfour S, Ayob MM, Mital A, Betha NJ. Perceived exertion of physical effort for various manual handling tasks. *Am. Ind. Hyg Assoc. J.* 1983; 44:223-8.
3. Bagian JP, Tripp, McCloskey K, Arnold A. The effect of graded hypoxia on regional cerebral oxygenation. *Aviat. Space Environ. Med.* 1994; 65: 477.
4. Balldin UI, Krock LP, Linder J, Siegborn J. Operational G-tolerance is not decreased with an immersion protection garment worn under the extended coverage anti-G suit. *SAFE JOURNAL* 1994; 24 (3): 24-28.
5. Balldin UI, Krock LP, Linder J, Siegborn J. The need for limiting extended simulated aerial combat maneuver G-exposures in acceleration research. In: *Proceedings of the 41st International Congress of Aviation and Space Medicine, Hamburg 1993.* Draeger J, Schwartz R, ed. Monduzzi Editore, Bologna, Italy. 1993:237-40.
6. Balldin UI, Kuronen P, Rusko H, Svensson E. Perceived exertion during submaximal G exposures before and after physical training. *Aviat. Space Environ. Med.* 1994; 65:199-203.
7. Balldin UI, Werchan P, Eddy T. Remote control of Transcranial Doppler (TCD) probe during centrifuge exposures up to 9 +Gz. *SAFE* 1994; 24:36-42.
8. Bergh U. Perceived exertion during exercise at different body temperatures. In: Borg G, Ottoson D, ed. *The perception of exertion in physical work. Proceedings. Wenner-Gren Center International Symposium Series, Stockholm, 1986;* 46:123-34.
9. Borg G. Psychophysical bases of perceived exertion. *Med. Sci. Sport Exer.* 1982;5:377-81.
10. Borg G. Some studies of perceived exertion in sports. In: Borg G, Ottoson D, ed. *The perception of exertion in physical work. Proceedings. Wenner-Gren Center International Symposium Series, Stockholm, 1986;* 46:293-302.
11. Borg G, Johansson S-E. The growth of perceived exertion during a prolonged bicycle ergometer test at a constant workload. In: Borg G, Ottoson D, ed. *The perception of exertion in physical work. Proceedings. Wenner-Gren Center International Symposium Series., Stockholm, 1986;* 46:47-55.
12. Buick F, Maloan J. Ear opacity shows head-level blood flow cycling during steady state exposures to +Gz. (Abstract) *Aviat. Space Environ. Med.* 1992; 63:419.
13. Ceci R, Borg G, Borg P, Johansson S-E. Perceived exertion, heart rate and blood lactate in downhill skiing as compared to cross country skiing - A pilot study. In: Borg G, Ottoson D, ed. *The perception of exertion in physical work. Proceedings. Wenner-Gren Center International Symposium Series, Stockholm, 1986;* 46:303-15.
14. Dahlback GO, Balldin UI. Physiological effects of pressure demand masks during heavy exercise. *Am. Ind. Hyg. Assoc. J.* 1984; 45:177-81.
15. Dahlback GO, Balldin UI. Pulmonary atelectasis formation during diving with closed-circuit oxygen breathing apparatus. *Undersea Biomed. Res.* 1985; 12:129-37.

16. Desmond JL, Werchan PM. Transcranial Doppler stabilization during acceleration and maximal exercise tests. Proceedings of the SAFE Association. 1991.
17. Fleishman E, Gebhardt DL, Hogan JC. the perception of physical effort in job tasks. In: Borg G, Ottoson D, ed. The perception of exertion in physical work. Proceedings. Wenner-Gren Center International Symposium Series, Stockholm, 1986; 46:225-42.
18. Glaister DH. Current and emerging technology in G-LOC detection: noninvasive monitoring of cerebral microcirculation using near infrared. Aviat. Space Environ. Med. 1988; 59:23-8
19. Hrebien L. Current and emerging technology in G-LOC detection: pulse wave delay for +Gz tolerance assessment. Aviat. Space Environ. Med. 1988; 59:29-31.
20. Imholz BPM, Settels JJ, van der Meiracker AH, Wesseling KH, Wieling W. Non-invasive continuous finger blood pressure measurements during orthostatic stress compared to intraarterial pressure. Cardiovasc. Res. 1990; 24:214-21.
21. Imholz BPM, van Montrans GA, Settels JJ, van der Hoeven GMA, Karemaker JM, Wieling W. Continuous non-invasive blood pressure monitoring: reliability of Finapres device during the Valsalva manoeuvre. Cardiovasc. Res. 1988; 22:390-7.
22. Kobayashi H, Mizumoto C, Nakamura A, Shimazu H. Indirect monitoring system for eye level blood pressure and gray/black out during Gz loading. Aviat. Space Environ. Med. 1994; 65:481.
23. Krock LP, Russell RL, Siegborn J, Balldin UI. Reduced pressure in extended coverage anti-G trousers with assisted pressure breathing. Aviat. Space Environ. Med. 1994; 65:287-92.
24. Krutz RW, Rositano SA, Mancini RE. Correlations of eye-level blood flow velocity and blood pressure during +Gz acceleration. USAF School of Aerospace Medicine, Brooks AFB, Texas. Report SAM-TR 73-36, 1973:1-5.
25. Laughlin MH, Burns JW, Loxsom FL. The use of microspheres in the measurement of regional blood flows during +Gz stress. J. Appl. Physiol. 1979; 47:1148-56.
26. Likert RA. A technique for the measurements of attitudes. Arch. Psychol., N.Y., 1932, 140: 1-55.
27. McKenzie I. Non-invasive blood pressure measurements under G. In: Proceedings of the 28th Annual SAFE Symposium. Yoncalla, OR. 1990:7-11.
28. Njemanze PC, Antol PJ, Lundgren CEG. Perfusion of the visual cortex during pressure breathing at different high-G stress profiles. Aviat. Space Environ. Med. 1993; 64:396-400.
29. Ossard G, Clere J-M, Kerguelen M, Melchior F, Seylaz J. Response of human cerebral blood flow to +Gz accelerations. J. Appl. Physiol. 76(5): 2114-2118, 1994.
30. Penaz, J. Photoelectric measurements of blood pressure, volume and flow in the finger. In Digest of the Xth International Conference on Medicine and Biological Engineering. Dresden: 1973: 104-110.
31. Prior ARJ, Adcock TR, McCarthy GW. In-flight arterial blood pressure changes during -Gz to +Gz maneuvering. Aviat. Space Environ. Med. 1993; 64:428.
32. Self DA, White CD, Hainsworth R. Venous pooling does not accompany syncope resulting from acceleration stress in subjects wearing anti-G suits. Aviat. Space Environ. Med. 1995; 00:00-00.
33. Stranges SF, Eddy TC. A microcomputer controller for a transcranial Doppler helmet. Aviat. Space Environ. Med. 1994; 65:481.

34. Tripp LD, Chelette TL. Cerebral blood flow during +Gz acceleration as measured by transcranial Doppler. *J.Clin. Pharmacol.*, 1991, 31:911-914.
35. Watkin J, Woodcock J, Stone J. Direct measurement of cardiac output in man during parabolic flight using Doppler ultrasound. *Aviat. Space Environ. Med.* 1994; 65:478.
36. Werchan PM, Echon RM, Barber JA, Galindo S, Shahed AR. Estimation of rat cerebral blood flow (CBF) during +Gz centrifuge exposures leading to G-induced loss of consciousness (G-LOC). *Society for Neurosci. Abstr.*, (19) 2:1220, 1993.
37. Werchan PM, Schadt JC, Fanton JW, Laughlin MH. Cerebral and spinal cord blood flow dynamics during high sustained +Gz. *Aviat. Space Environ. Med.* 1994; 65:501-9.
38. Wood EH, Lambert EH. Objective documentation and monitoring of Gz tolerance. *SAFE J.* 1989; 19:39-48.
39. Wood EH, Buick F. Objective quantification of +Gz-tolerance and efficiency of protective devices and procedures. *Aviat. Space Environ. Med.* 1994; 65:480.
40. Yoshimoto S, Ueno T, Miyamoto A, Nagaoka S, Ishikura S, Yamagata M, Watanabae S. Cerebral circulation during parabolic flight measured by near-infrared spectrophotometer. *Aviat. Space Environ. Med.* 1994; 65:458.
41. Young AJ, Cymerman A, Pandolf KB. Differentiated rating of perceived exertion are influenced by high altitude exposure. *Med. Sci. Sports Exerc.* 1982; 14:223-8.

METHODS FOR MEASURING PHYSIOLOGICAL RESPONSES AND PROTECTION IN MAN EXPOSED TO HIGH +Gz

F. Buick†, E.H. Wood††, M. Pecaric†, J. Maloan†

† Defence and Civil Institute of Environmental Medicine
North York, Ontario, Canada M3M 3B9

†† Mayo Foundation
Rochester, MN, 55905, U.S.A.

SUMMARY

The often-used subjective measurements of +Gz tolerance are inadequate because they are prone to subjective bias and cannot document the time-dependent changes in the reacting physiology. This lecture describes non-invasive, objective measurements used to measure the human subject's physiological status, to monitor physiological reactions in order to compare the +Gz protective value of various +Gz countermeasures, and to measure endpoints which will guide the termination of +Gz exposure.

LIST OF SYMBOLS

- +Gz the inertial force vector acting in the forward direction
- e.g. +7Gz the inertial force vector with an absolute magnitude 7 times normal gravity; most commonly used to describe the amount of force acting on the body
- e.g. 7+Gz a general inertial force vector 7 times the normal gravity beginning from any level of force; typically used to describe a change in +Gz

1.0 INTRODUCTION

The human centrifuge offers a good platform with which to simulate some of the forces acting on the body as they might occur during high speed and maneuverable flight (13, 14). Using such a facility has led to the development of various methods for protecting against the effects of high +Gz exposure, methods such as the G-suit (24), the anti-G straining maneuver (23), and centrifuge training (10). These were important developments because exposure to high +Gz can lead to unconsciousness and potentially fatal consequences should it occur during flight.

Means of measuring the physiological responses and protection in humans exposed to high +Gz are as varied

as the number of laboratories studying these problems. This lecture will describe the procedures we are currently using at DCIEM.

2.0 METHODS FOR MEASURING +Gz PHYSIOLOGICAL RESPONSES AND PROTECTION

Conducting experiments in the centrifuge can be complicated. +Gz exposure is stressful for the centrifuge riders, their physiological changes can develop rapidly, and they are isolated from experimental personnel. The following principles have guided our methodology:

- (i) expose the subject to no greater magnitude or duration of +Gz than is required to satisfy the requirements of the experimental protocol;
- (ii) collect as much information as is necessary to ensure adequate description of the physiological changes and have confidence in those measurements.

Much of our efforts over the past several years have been aimed at understanding/measuring the physiological limits relevant to issues of +Gz tolerance and +Gz protection. We have endeavored to make our measurements as objective as possible. While comments from the centrifuge rider on the percentage vision loss during the preceding centrifuge profile are satisfactory in some instances, there are several problems when this measure becomes the primary metric for quantifying +Gz tolerance:

- (i) it is subjective and determined by the rider's ability to integrate and recollect a complex response, especially when anti-G straining maneuvers are involved;
- (ii) subjective measurements generally require more frequent profiles to reduce within-subject variability;
- (iii) changes in +Gz level during flight tend to be in the rapid-G-onset-rate range (>1+Gz/s)

and the head-level blood pressure and vision reactions are transient which cannot be documented by a single measurement;

(iv) in rapid +Gz onset profiles, there is insufficient time for warning signs of potential losses of vision and/or consciousness.

2.1 EXPERIMENTAL PROFILES

We are generally interested in measuring the physiological reactions to different +Gz levels or the "stimulus and the response". Also, we wish to find the +Gz level which evokes a predetermined endpoint in a particular subject. This endpoint would be used to measure +Gz tolerance. This follows the "bio-assay" approach developed for +Gz investigations by the Mayo Aeromedical Unit during the 1940s (1). A graph displaying the changes in some physiological variable (the dependent variable) with respect to +Gz level (the independent variable) offers a useful depiction of the progressive physiological deterioration with +Gz intensity and its improvement with +Gz protective procedures. The extent to which the physiological changes are transposed on the graph are a measure of the +Gz protection (see later discussion of Figures 6-8, 11).

Many of our investigations employ the relaxed, rapid +Gz onset rate with plateau centrifuge profile, for the following reasons:

(i) The rapid +Gz onset rate profile puts the greatest demand on our physiology, its adaptations, and on the performance of any +Gz protective procedure. In our centrifuge, the maximum rate is 2+Gz/s when the baseline is +1.4Gz. (While a slightly faster onset rate would be achieved by slight elevation of the baseline +Gz, our aim to maximally stress the cardiovascular system is achieved by the greatest Δ +Gz, i.e. from the lowest practical baseline +Gz possible.)

(ii) The centrifuge plateau is usually 15-20s. This is sufficient to expose the period of progressive failure and the subsequent period of compensation of the cardiovascular system. Thus, there will be a phase when the subject is at his most +Gz intolerant state, and susceptible to +Gz-induced loss of consciousness, followed by a phase whereby his reflexes will be fully activated.

(iii) The subject is usually relaxed during our investigations. While all of our centrifuge riders are trained in the use of anti-G straining maneuvers, accumulated physical fatigue and the need for a volition component to determine an experiment endpoint complicate the reproducibility of the physiological reaction under study.

(iv) While still using primarily rapid +Gz onset rate profiles, recently we have modified the centrifuge profiles by employing a fixed rise-time for the Δ +Gz (e.g. 3 s). Within limits, the time taken from baseline +Gz to any plateau +Gz is predetermined for an experiment. Thus, the time for cardiovascular reflexes to react will be constant at the moment the +Gz plateau is reached, regardless of the +Gz level of the plateau. If a constant +Gz onset rate were used for all profiles, it would take longer to reach the higher +Gz levels than the lower ones.

In a typical experiment, the order of profiles would expose the subject to a set of successive profiles from low +Gz to high +Gz and/or his endpoint. If this were the control condition, e.g. relaxed and without G-suit protection, it would be followed by the experimental condition. The same set of profiles carried out to the endpoint criterion would be used, this time with a G-suit. Ideally, the control responses should be verified at the end of the experiment, but sometimes only one or two profiles around the control +Gz tolerance or endpoint level can be repeated.

Keeping the total number of profiles to a practical level is important. Our subjects seem comfortable participating in 20 successive profiles separated by a short rest. It is important that the subject begins each profile from the same physiological condition. At least 1 min of recovery between profiles has been recommended (7). The total number of profiles will be determined by the +Gz increment between successive profiles. Some use 0.3 +Gz (20) which allows good discrimination of +Gz tolerance. To limit the number of profiles in one experimental session with two experimental conditions, we resort to 0.5+Gz increments, and further reason that potential +Gz protective procedures which fail to increase +Gz tolerance by at least 0.5 +Gz merit no additional study. The Table is a reproduction of the record sheet from one of our investigations showing the run-by-run account of +Gz exposure, the experimental conditions, the acceptability of the light bar and ear pulse recordings, and the subjective visual responses.

2.2 MEASUREMENTS

2.2.1 Mechanical

Before attributing any effect to +Gz intensity or the +Gz protective value of different procedures, +Gz levels and mechanical conditions must be verified. Our data acquisition system, both polygraph and computer, record the gondola accelerometer output and pressure in any of the life support equipment components, e.g. G-suit, oronasal mask cavity, jerkin. To confirm that subjects were relaxed during profiles, we record electromyographic activity from vastus lateralis, rectus abdominis, and intercostal muscles. A pneumograph could be placed around the rib cage to monitor chest wall motion and guard against possible breath-holding and straining. Until the mechanical conditions of the

+Gz exposure have been verified, no assessment or comparison of the physiological reactions should be made.

2.2.2 Physiological

The following sections describe our most frequent physiological measures in studies of +Gz protection. Most of our attention is directed to the cardiovascular and visual systems.

2.2.2.1 Electrocardiogram:

The five-lead electrocardiogram is the one measurement made on all centrifuge riders at DCIEM when they are exposed to greater than +3Gz, research or training alike. It helps the Flight Surgeon monitor the subject and the R-R interval from the EKG is used to calculate heart rate.

2.2.2.2 Blood Pressure:

The very thorough studies conducted at the Mayo Aeromedical Unit during the 1940s and '50s (24, 26) have given us much information about the cardiovascular aspects of human +Gz exposure. Those invasive studies are difficult to replicate today; however, advances in technology now give us the ability to perform some of these measurements indirectly.

Blood pressure at heart level is measured with the Finapres unit (4). While wrapped around a finger, a cuff-with-bladder photo-electric-plethysmographically controls arterial inflow to digit tissue to produce a real-time pressure waveform. Since any hydrostatic pressure differences are magnified by +Gz, it is essential that the relationship of finger position to a point of reference be known. Our standard procedure is to place the cuff on the middle finger of the left hand which crosses the chest at a level putting the cuff at the third intercostal space, approximately the location of the aortic valve. The forearm and hand are supported in a non-slip sling with the straps secured around the back of the neck. In this way, should the hand and chest be displaced during +Gz, they do so in concert. Keeping the thumb perpendicular to the forearm/hand midline appears to prevent the occasional loss of the blood pressure waveform during +Gz exposure.

2.2.2.3 Ear Opacity:

Blood in the ear, as measured by photo-electric plethysmography, is used as a marker of head-level perfusion. We use a non-invasive and non-obtrusive device to measure ear opacity fabricated after the design principles (28) first used at the Mayo Aeromedical Unit in the 1940s (Figure 1). Light from the unit is emitted at a wavelength of ~800 nm onto the ear surface. Hemoglobin absorbs this light, therefore, changes in the intensity of transmitted light detected at the photocell behind the ear are due to changes in total blood content. The lamp portion of the ear-piece is adjusted until the ear rests next to the detector. A strong opacity pulse indicates correct positioning of the ear-piece.

Ear blood flow and blood volume in the control condition at +1Gz must be stable. While thermogenic ointments can raise local blood volume within 20 min, our experience to date shows the effect to be transitory. Heating the pinna may produce a more stable blood volume level. In the Mayo earpiece, the lamp, in addition to providing the light source, heated the ear locally. This feature is lost in designs using solid-state components.

Similarly, the earpiece position must be stable. Plaster casts on the head provide a strong base for the supporting rod on which the earpiece is mounted. Head bands are also useful. Unfortunately, neither of these techniques is possible when helmets are used and earpiece size must be reduced to only its essential electronic components.

The oscillographic measurement of light transmission through the ear is filtered producing two recordings:

(i) Ear Opacity - The component of the detector output between DC-5 Hz produces the ear opacity record, the relatively low frequency changes in light transmission caused by changes in overall blood content of the ear.

(ii) Ear Opacity Pulse - This recording is derived from those output components between 1-5 Hz. It shows the rate of change of blood content produced by each heart beat.

The voltage output of the photocell is inverted so that increases in light transmission during +Gz show decreases in ear opacity, i.e. the blood content of the ear has decreased. Subsequent logarithmic transformation can express opacity output in terms of blood content as %Δ from rest.

It is possible to calibrate the ear opacity unit. Referring to Figure 2, the position of the ear opacity signal when the lamp is off simulates complete light absorption (artificial condition of maximum blood content). Calibration for the minimum opacity condition (maximum light transmission or a "bloodless" ear) is achieved by occlusion of local ear flow by pressurization of a miniature pneumatic capsule on the light source side of the ear-piece. Graded reductions in blood content of the pinna at +1Gz are produced by incremental capsule pressures which simulate the effect of decreased blood pressure at ear level during hypergravity. The Figure shows that as capsule pressure is increased from 20 to 100 mmHg, ear opacity is reduced. The ear opacity pulse is finally obliterated with a pressure of 120 mmHg.

2.2.2.4 Respiratory Measurements:

In some studies, it may be necessary to measure ventilation and/or inspiratory and expiratory flow. Calibrated pneumotachographs have performed satisfactorily for us in the centrifuge. A normal breathing pattern during +Gz exposure provides assurance that the rider is not

using the respiratory component of the straining maneuver. The inductance plethysmograph Resptrace and, as stated earlier, the pneumograph, also provide this information.

2.2.2.5 Vision:

We use two methods to measure the status of the visual field during +Gz exposure.

Semi-Objective. The centrifuge gondola contains a light bar situated 60 cm in front of the subject at eye-level. In addition to the central red light emitting diode (LED), there are two green LEDs positioned at 25 degrees from center of the visual field. The subject is instructed to focus on the center light at all times during hypergravity. When either the center LED or the peripheral LEDs are illuminated, the rider is to extinguish them as quickly as possible using finger-activated switches on the center/side control stick. Figure 3 shows the process. Each upward displacement on the peripheral or central visual field light record marks the illumination time of the LED. The deflection returns to baseline when the LED is switched off by the subject. The lights are presented in semi-random fashion by a technician monitoring the subject's responses. An unextinguished LED is evidence of complete light loss in that region of the visual field, the duration of which can be easily measured by the time between light on and off. The ability to detect an illuminated light bar LED will be affected by both the ambient light in the gondola and the intensity of the LED. Therefore, these must remain constant.

Subjective. After each +Gz exposure, the subject is asked to rate his vision during the exposure using the following descriptors:

- clear - vision was as clear as at rest;
- dim - less than one-half of normal vision lost;
- grey - over half of normal vision lost, but could still see the LED;
- peripheral light loss (PLL) - unable to see peripheral LEDs;
- central light loss (CLL) - unable to see central LED.

These descriptors are used to rate four situations: (i) worst status of vision in peripheral field; (ii) worst status of vision in central field; (iii) best status of vision in peripheral field after the situation in (i); and (iv) best status of vision in central field after the situation in (ii). These responses are recorded on the data sheet shown in the Table.

Any discrepancies between the subjective and the semi-objective assessment of visual status in the preceding profile are queried immediately.

3.0 OBSERVATIONS

3.1 CIRCULATORY RESPONSES DURING +Gz

Some of the measurements from one subject in an experiment with an extended coverage G-suit are reproduced in Figure 3. In the left panel of the Figure, accelerometer output shows smooth rapid +Gz onset from +1.4Gz baseline reaching +5Gz sustained for 20 s. The G-valve responded properly as indicated by the G-suit pressure record and respiration was continuous as confirmed by the rhythmic movement of the chest wall. As +Gz and G-suit pressure increase, systolic blood pressure begins to increase from the resting value of 130 mmHg. Head-level blood pressure is lowered in the early phases as reflected by the decreased ear opacity level and the decreased amplitude of the ear opacity pulse. The lowest pulse amplitude occurred 4.5 s after leaving baseline +Gz. Only when heart-level blood pressure reached 160 mmHg, 2 s after plateau +Gz, is there recovery of ear pulse amplitude and ear blood content. The peripheral light response shows the well-known delayed reaction of the development of visual symptoms. This subject experienced peripheral light loss 6.5 s after baseline +Gz. The time-dependent circulatory changes correlate with the impairment of vision (22). Complete visual blackout occurred after a secondary decrease in head-level perfusion. Despite increased G-suit pressure in the +5.5Gz exposure shown in the right panel of Figure 3, the further increased hydrostatic gradients result in complete loss of ear pulse. The pulse is obliterated when brain-level arterial pressure falls to zero. When 3-4 s of ear pulse obliteration is observed during any +Gz exposure, the profile is terminated to avoid possible loss of consciousness. This subject only experienced peripheral light loss on the moment of deceleration. Close inspection of the ear pulse shows slight improvement as the run was being terminated. The profile was repeated and the subject completed the run with virtually identical physiological responses, but with complete visual blackout.

This example shows how obliteration of the ear pulse is an objective and unmistakable endpoint. Attainment of a pre-determined endpoint terminates +Gz exposure. The ear pulse endpoint is reproducible and has the added feature that it manifests itself near the subject's +Gz tolerance level. Obliteration of the ear pulse is also a useful warning sign for potential loss of consciousness. The average time from abolished ear pulse until unconsciousness is 6 - 7 s (2, 21).

3.2 MEASURING +Gz TOLERANCE AND +Gz PROTECTION

+Gz tolerance can be any metric used to describe the capacity of an individual to withstand +Gz exposure with or without the development of measurable bodily reactions. These reactions could be of any nature such as physiological, sensory, motor, cognitive, or performance-based. Physiological +Gz tolerance is generally described more specifically as either +Gz intensity tolerance or +Gz duration tolerance. The Canadian Forces have no aircraft which can sustain high levels of +Gz;

therefore, most of our studies focus on +Gz intensity tolerance, that +Gz level producing a reliable, reproducible, and measurable physiological symptom or set of symptoms. Of course qualifiers such as protection (e.g. relaxed or straining) and type of centrifuge profile must be clearly described when quoting +Gz tolerance values. For a group of 15 relaxed and unprotected subjects exposed to 15 s rapid +Gz onset rate profiles, the average +Gz level at which ear pulse was abolished was +4.0Gz (range +3.0 to +5.0Gz) (13).

The +Gz protective value of any procedure or equipment must be described with the same considerations for measurement and description as for +Gz tolerance. Whereas +Gz tolerance relies ultimately on the responses to one +Gz level, this need not necessarily be the case for quantifying +Gz protection. The physiological changes over several +Gz levels are monitored and then compared in different +Gz protection conditions. Therefore, observations at submaximal +Gz levels could be sufficient to adequately measure +Gz protection.

Figure 4 shows a series of successive +Gz profiles and oscillographic recordings from a 1943 bio-assay performed at the Mayo Aeromedical Unit centrifuge studying protection from the Progressive Arterial Occlusion Suit (PAOS). In the third tracing from top (Run no. 2AA-13), there is zero ear pulse at onset of +5Gz plateau and a subsequent 5 s (retinal anoxic reserve time) failure to respond to peripheral light signal (PLL). Next, there is compensatory recovery of ear pulse 7 s after plateau onset, followed by two secondary failures at cyclic 10 s intervals, and a corresponding 5 s delayed PLL. Maintenance of the ear pulse and peripheral light responses at +8Gz with pressure in the suit (Run no. 2AA-10) shows a protective value of > 3 +Gz. Similarly, the suit plus the M-1 maneuver (Run no. 2AA-11) shows a protective value > 5 +Gz.

Figure 5 shows the kymograph recordings corresponding to the +Gz exposures in Figure 4. The top channel displays respiratory tidal volume. The central channel records ear opacity as a shadow (white tracing) of the sensing filament, the "string", of an Einthoven string galvanometer. In this Figure only, upward deflection indicates decreased ear opacity, i.e. loss of blood content. Vertical white lines delineate 5 s intervals. The peak deflections in ear opacity at +6 and +8Gz with suit pressurized (Run no. 2AA 6 and 10) were similar to control run deflections (Run no. 2AA 3, 12 and 13). These equivalent objective indices of decreased circulation at brain level document a protective value for the suit of 3.3 +Gz (see Figure 6). Note the compensatory increases of ear blood content which began about 7 s after onset of plateau +Gz followed by secondary failures at cyclic 10 s intervals as seen in Run no. 2AA-13 (Run 2AA-13 was a control recheck of an earlier exposure to +5Gz).

Figure 6 shows the graphic measurement of protection of the PAOS suit based on indices of the circulatory changes at brain level shown in Figures 4 and 5. The cross-hatched region, which covers the area of equivalent

decrements in ear blood content with and without suit protection, documents a protective value for the PAOS suit of 3.3 +Gz for this subject. The cyclic increases in ear opacity to near the +1Gz control level during the exposure to +9Gz with the M-1 straining maneuver and the PAOS indicates a total protective value of > 5 +Gz for this experienced subject.

From a subject on the DCIEM Centrifuge, Figure 7 shows the quantitative measurement of protection of the standard 5-bladder G-suit based again on circulatory changes from photoelectric plethysmography. The axes have been reversed from that in Figure 6 to show an alternate display method. The Figure shows %Δ in blood content from rest as measured after 5 s at different plateau +Gz levels for a subject. Using the asymptote of the change in blood content as a definition of +Gz tolerance, the +Gz tolerance was +4.0Gz without a G-suit and +5.2Gz with a standard 5-bladder G-suit. Therefore the +Gz protective value of the suit was 1.2+Gz.

The amplitude of the ear opacity pulse, when below 100% control, is related to head-level blood pressure. In Figure 8, the equivalent decrements in pulse amplitude with and without suit protection document a protective value for the standard suit of 1.2 +Gz for this subject.

The methods described in the preceding sections have been used most recently at DCIEM in the development of new +Gz protective equipment for use in the CF-18. Figure 9 show a video monitor view of a subject in the centrifuge. Heart rate and +Gz level are displayed in the upper right and left corners of the Figure, respectively (7.6G on the monitor is only a crude reading of the true heart-level value of +7.5Gz). Above the subject's right shoulder is a vertical arrangement of three LEDs indicating: (i) ear opacity pulse (light illuminated when pulse is present at ear pinna level); (ii) illumination of the central visual field stimulus (subject required to extinguish central visual field light on light bar in front); (iii) illumination of the peripheral visual field stimulus (subject required to extinguish peripheral visual field light on light bar).

Figure 10 shows a representative recording from an experiment using rapid onset rate +Gz profiles in the DCIEM centrifuge. In this run with a 3 s +Gz rise time and a 15 s +Gz plateau, a G-suit pressure of 420 mmHg and a mask cavity pressure of 78 mmHg combine to increase heart-level systolic blood pressure to 220 mmHg after 2 s at +7Gz. As shown by the ear opacity pulse, this level of blood pressure supports continuous circulation to head-level. This subject shows no significant muscle tension for the abdomen or legs. Heart rate was approximately 104 bpm during most of the run. Also, each time the lights in the peripheral and central visual field are illuminated, they are extinguished by the subject. From records such as these and from additional post-run assessment of the subjective visual light loss, it is possible to graph the progressive physiological deterioration with increasing +Gz level and any improvement provided by +Gz countermeasures.

Figure 11 shows the measurement of improved protection to the status of peripheral vision afforded by the combination of pressure breathing during +Gz (PBG) and an extended coverage G-suit. The visual status ratings apply to the subject's perception of his worst peripheral vision during the just-completed +Gz exposure. Equivalent symptoms of visual deterioration with the advanced +Gz protective system were not produced until +Gz levels ~ 2.5 units above control (i.e. with the standard G-suit) were reached. This also demonstrates the value of the bio-assay with subjective measurements. This particular bio-assay required 12 +Gz runs.

4.0 CONCLUSION

This series of recordings and graphs show the value of the bio-assay approach and non-invasive physiological monitoring for assessing the physiological effects of acceleration, and for objectively measuring +Gz tolerance and the +Gz protective value of various +Gz countermeasures. The responses can be compared at intermediate +Gz levels and at +Gz levels producing exposure endpoints such as zero ear pulse or visual light loss.

The methods described are those currently being used at DCIEM. Some of these, and other methods, have been documented elsewhere:

- endpoints (5, 12);
- bio-assay (2, 3, 8, 27);
- +Gz tolerance (6, 9, 11, 16, 17, 18);
- general methodology (15, 19, 20, 25).

5.0 REFERENCES

1. Baldes E, Code C, Lambert E, Wood E. Human centrifuge and studies of blackout. *J. Physiol.* (Lond.) 1945; 104.
2. Beckman E, Duane T, Ziegler J, Hunter H. Some observations on human tolerance to accelerative stress: Phase IV. Human tolerance to high positive G applied at a rate of 5 to 10 G per second. *J. Aviat. Med.* 1954; 25:50-66.
3. Bergeret P. Bio-assay Techniques for Human Centrifuges and Physiological Effects of Acceleration. NATO AGARD. New York: Pergamon Press, 1961: pp 176.
4. Boehmer R. FINAPRES. *Medical Electronics.* April, 1988, Reprint.
5. Coburn K. Physiological endpoints in acceleration research. *Aerospace Med.* 1970; 41:5-11.
6. Cochran L, Gand P, Norsworthy M. Variations in human G tolerance to positive acceleration. U.S. School of Aviation Medicine, Naval Air Station, Pensacola, Florida. Research Report NM001 059.02.10. August 31, 1954.
7. Denton A. A first run effect on the human centrifuge. Report No. 758. Institute of Aviation Medicine, Royal Air Force, Farnborough, Hants, United Kingdom. November 1993.
8. Downey VM, Lorentzen FV, Lambert EH. Effect of the crouch position on the increase in tolerance to positive acceleration afforded by an antiblackout suit. *J. Aviat. Med.* 1949; 20:289-299.
9. Edelberg R, Henry J, Maciolek J, Salzman E, Zuidema G. Comparison of human tolerance to accelerations of slow and rapid onset. *J. Aviat. Med.* 1956; 4:482-489.
10. Gillingham K, Fosdick J. High-G training for fighter aircrew. *Aviat. Space Environ. Med.* 1988; 59:12-19.
11. Krutz R, Rositano S, Mancini R. Comparison of techniques for measuring +Gz tolerance in man. *J. Appl. Physiol.* 1975; 38:1143-1145.
12. Kydd G, Fenichell R, Crosbie R. Relationship of carotid pressure and end point during acceleration. *J. Appl. Physiol.* 1960; 15:903-906.
13. Lambert E. Comparison of the physiologic effects of positive acceleration on a human centrifuge and in an airplane. *J. Aviat. Med.* 1949; 20:308-335.
14. Lambert E. Effects of positive acceleration on pilots in flight, with a comparison of the responses of pilots and passengers in an airplane and subjects on a human centrifuge. *J. Aviat. Med.* 1950; 21:195-220.
15. Leverett S, Zuidema G. Standardization of human centrifuge techniques. In: Gauer O, Zuidema G, ed. *Gravitational Stress in Aerospace Medicine.* Boston: Little, Brown and Company, 1961: Appendix 5, pp 263-270.
16. Ludwig D, Krock L. Errors in measurement of +Gz acceleration tolerance. *Aviat. Space Environ. Med.* 1991; 62:261-265.
17. Sandler H, Rositano S, McCutcheon E. An objective determination of +Gz acceleration tolerance. *Acta Astronautica* 1977; 4:541-553.
18. Stoll A. Human tolerance to positive G as determined by the physiological end points. *J. Aviat. Med.* 1956; 27:356-367.
19. van Patten R. The relevance of acceleration metrics. Proceedings of Twenty-seventh Annual Symposium of SAFE Association. New Orleans, LA, 1989: 211-213.
20. Whinnery J, Jackson W. Reproducibility of +Gz tolerance testing. *Aviat. Space Environ. Med.* 1979; 50:825-828.

21. Wood E. Development of anti-G suits and their limitations. *Aviat. Space Environ. Med.* 1987; 58:699-706.
22. Wood E. Some effects of the force environment on the heart, lungs and circulation. *Clin. Invest. Med.* 1987; 10:401-27.
23. Wood E, Hallenbeck G. Voluntary (self protective) maneuvers which can be used to increase man's tolerance to positive acceleration. *Fed. Proc.* 1945; 4:78-79.
24. Wood E, Lambert E. Some factors which influence the protection afforded by pneumatic anti-g suits. *J. Aviat. Med.* 1952; 23:218-228.
25. Wood E, Lambert E. Objective documentation and monitoring of human Gz tolerance when unprotected and when protected by anti-G suits or M-1 type straining manuevers alone or in combination. *SAFE J.* 1989; 19:39-48.
26. Wood E, Lambert E, Baldes E, Code C. Effects of acceleration in relation to aviation. *Fed. Proc.* 1946; 5:327-344.
27. Wood E, Lindberg E, Code C, Baldes E. Effect of partial immersion in water on response of healthy men to headward acceleration. 1963; 18:1171-1179.
28. Wood E, Sutterer W, Cronin L. Oximetry. In: Glasser O, ed. *Medical Physics, Vol. III.* Chicago, Ill: Year Book Publishers Inc., 1960: 416-445.

6.0 ILLUSTRATIONS

Table. Reproduction of part of run record sheet from human centrifuge experiment at DCIEM.

CONTROL		RUN COMPLETION										VISION: Clear, Dim, Grey, Black	COGN	QUESTIONNAIRE		OTHER	
run#	video tape time	Gz Plateau	Condition control - exper +	AGSM at G onset no (-), yes (+)	PBG, no (-), yes (+)	15s plateau completad? ✓	Early stop	Light bar record Satisfac t?	Ear pulse record Satisfac t?	AGSM intensi ty (mild, moder ate, or heavy)	Worst periph'l vision status	Worst central vision status	Best periph'l vision status	Best central vision status	Cognitive status (clear, hazy, poss GLOC, def GLOC)	ECG	Other Investigator or subject remarks
1	10:49	4.0	-	-	-	✓		✓	✓	-	CDGB	CDGB	CDGB	CDGB	C		OK
2	10:53	5.0	-	-	-	✓		✓	✓	-	CDGB	CDGB	CDGB	CDGB	C		OK
3	10:56	5.5	-	-	-	✓		✓	✓	-	CDGB	CDGB	CDGB	CDGB	C		OK
4	10:59	6.0	-	-	-	✓		✓	✓	-	CDGB	CDGB	CDGB	CDGB	C		OK
5	11:01	6.5	-	-	-	✓		✓	✓	-	CDGB	CDGB	CDGB	CDGB	C		OK
6	11:05	5.0	-	-	+	✓		✓	✓	-	CDGB	CDGB	CDGB	CDGB	C		OK
7	11:07	6.0	-	-	+	✓		✓	✓	-	CDGB	CDGB	CDGB	CDGB	C		OK
8	11:09	7.0	-	-	+	✓	✓	✓	✓	-	CDGB	CDGB	CDGB	CDGB	C		OK
9											CDGB	CDGB	CDGB	CDGB	C		OK
10	11:12	6.5	-	-	+	✓		✓	✓	-	CDGB	CDGB	CDGB	CDGB	C		OK
11	11:14	7.0	-	-	+	✓		✓	✓	-	CDGB	CDGB	CDGB	CDGB	C		OK
12	11:18	5.5	-	-	+	✓		✓	✓	-	CDGB	CDGB	CDGB	CDGB	C		OK
13	11:21	4.5	-	-	+	✓		✓	✓	-	CDGB	CDGB	CDGB	CDGB	C		OK
14	11:26	5.0	+	-	+	✓		✓	✓	-	CDGB	CDGB	CDGB	CDGB	C		OK
15	11:27	6.0	+	-	+	✓		✓	✓	-	CDGB	CDGB	CDGB	CDGB	C		OK
16	11:30	7.0	+	-	+	✓		✓	✓	-	CDGB	CDGB	CDGB	CDGB	C		OK
17	11:32	7.5	+	-	+	✓		✓	✓	-	CDGB	CDGB	CDGB	CDGB	C		OK
18	11:35	4.5	+	-	+	✓		✓	✓	-	CDGB	CDGB	CDGB	CDGB	C		OK
19	11:37	5.5	+	-	+	✓		✓	✓	-	CDGB	CDGB	CDGB	CDGB	C		OK
20	11:39	4.0	+	-	+	✓		✓	✓	-	CDGB	CDGB	CDGB	CDGB	C		OK
21	11:41	5.0	+	-	+	✓		✓	✓	-	CDGB	CDGB	CDGB	CDGB	C		OK
22	11:43	5.5	+	-	+	✓		✓	✓	-	CDGB	CDGB	CDGB	CDGB	C		OK
23	11:46	4.5	-	-	-	✓		✓	✓	-	CDGB	CDGB	CDGB	CDGB	C		OK
24											CDGB	CDGB	CDGB	CDGB	C		OK
25											CDGB	CDGB	CDGB	CDGB	C		OK
26											CDGB	CDGB	CDGB	CDGB	C		OK
27											CDGB	CDGB	CDGB	CDGB	C		OK
28											CDGB	CDGB	CDGB	CDGB	C		OK
29											CDGB	CDGB	CDGB	CDGB	C		OK
30											CDGB	CDGB	CDGB	CDGB	C		OK

Figure 1. Original ear piece and clamp assembly for measuring ear opacity at Mayo Aeromedical Unit in 1940s. Recent prototype ear pieces are similar.

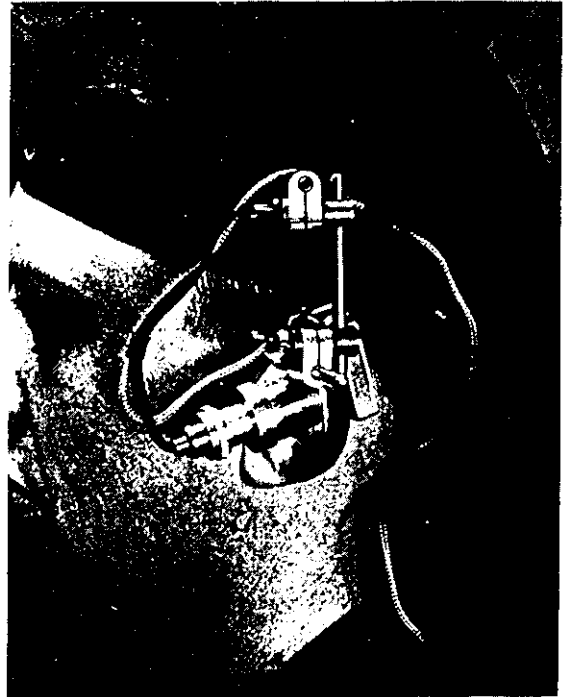

Figure 2. Calibration of ear opacity measurement system at +1Gz with incremental capsule pressures reducing blood content (ear opacity) and obliterating ear opacity pulse.

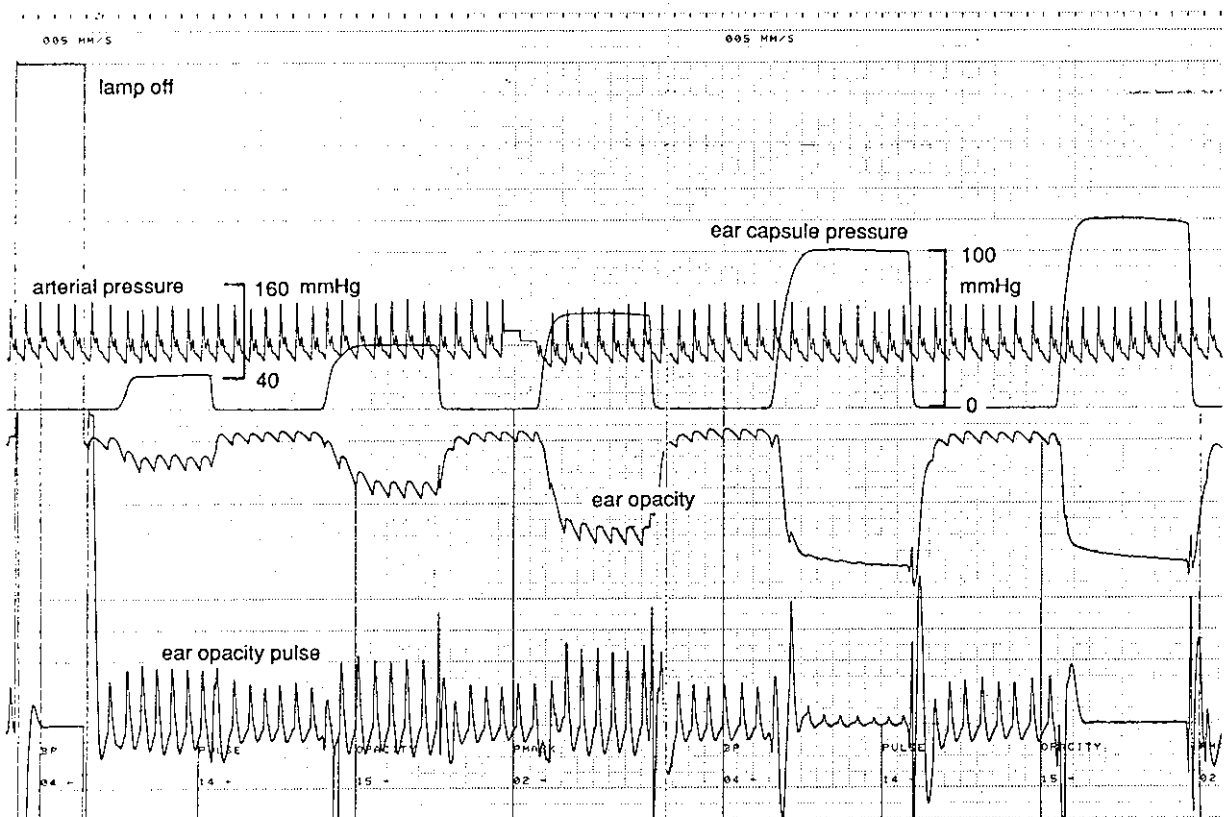

Figure 3. Recording of hypergravity exposure from human subject relaxed and wearing extended coverage G-suit on DCIEM centrifuge in 1993. Left panel shows full-duration exposure to +5Gz and right panel shows exposure to +5.5Gz terminated early due to zero ear opacity pulse.

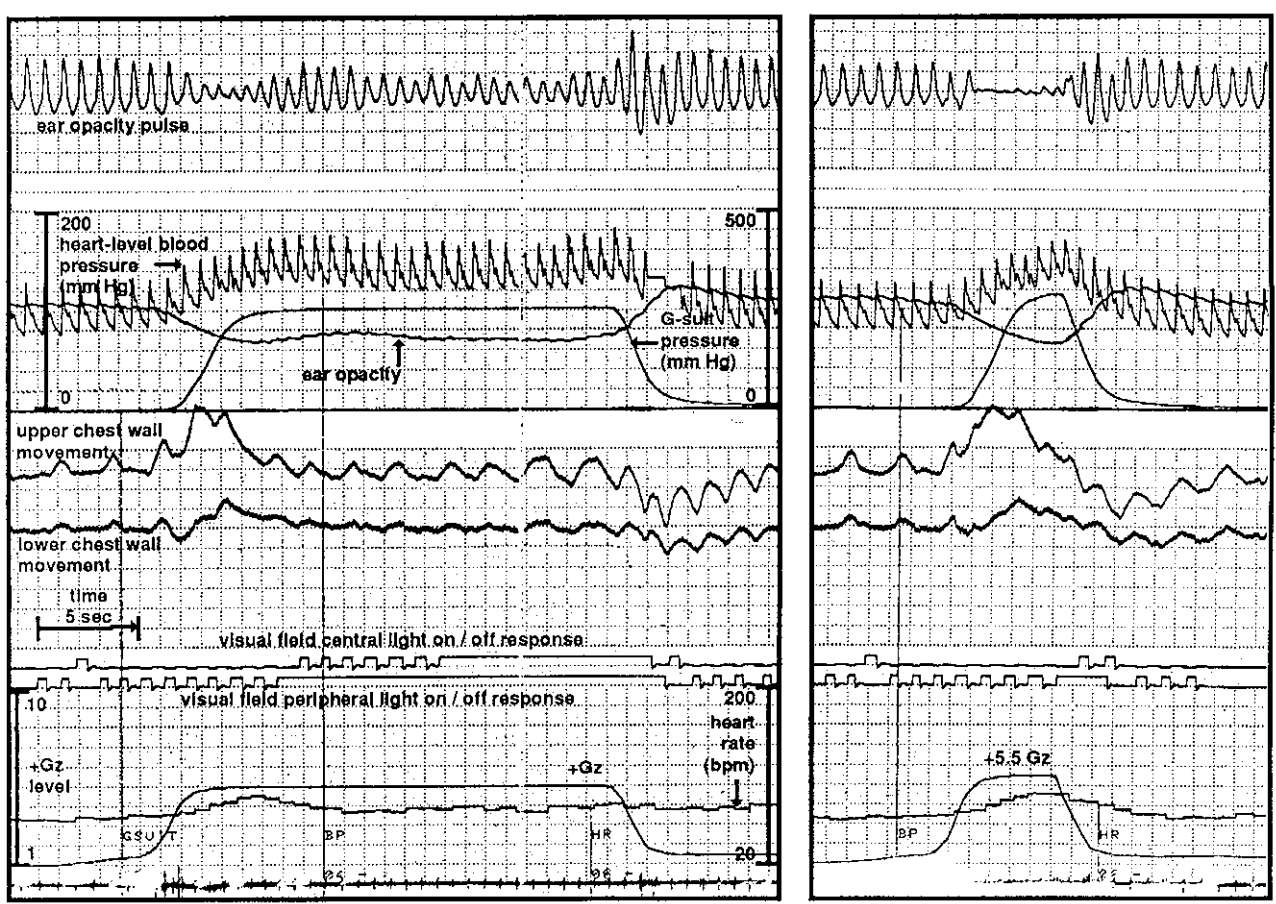

Figure 4 Successive top-to-bottom oscillographic recordings from bio-assay of +Gz protection from Progressive Arterial Occlusion Suit (with occlusive arm cuffs) performed at Mayo Aeromedical Unit on 16 February 1943. Top left hand corner of the Figure identifies the channels: light response, ear flow pulse, sound response, synchronization and 1 sec signal, electrocardiogram, (Subject No. 2AA), and acceleration.



Figure 5. Photokymographic recordings made synchronously with those shown in Figure 4.
 Vision: PLL - peripheral light loss; CLL - central light loss.

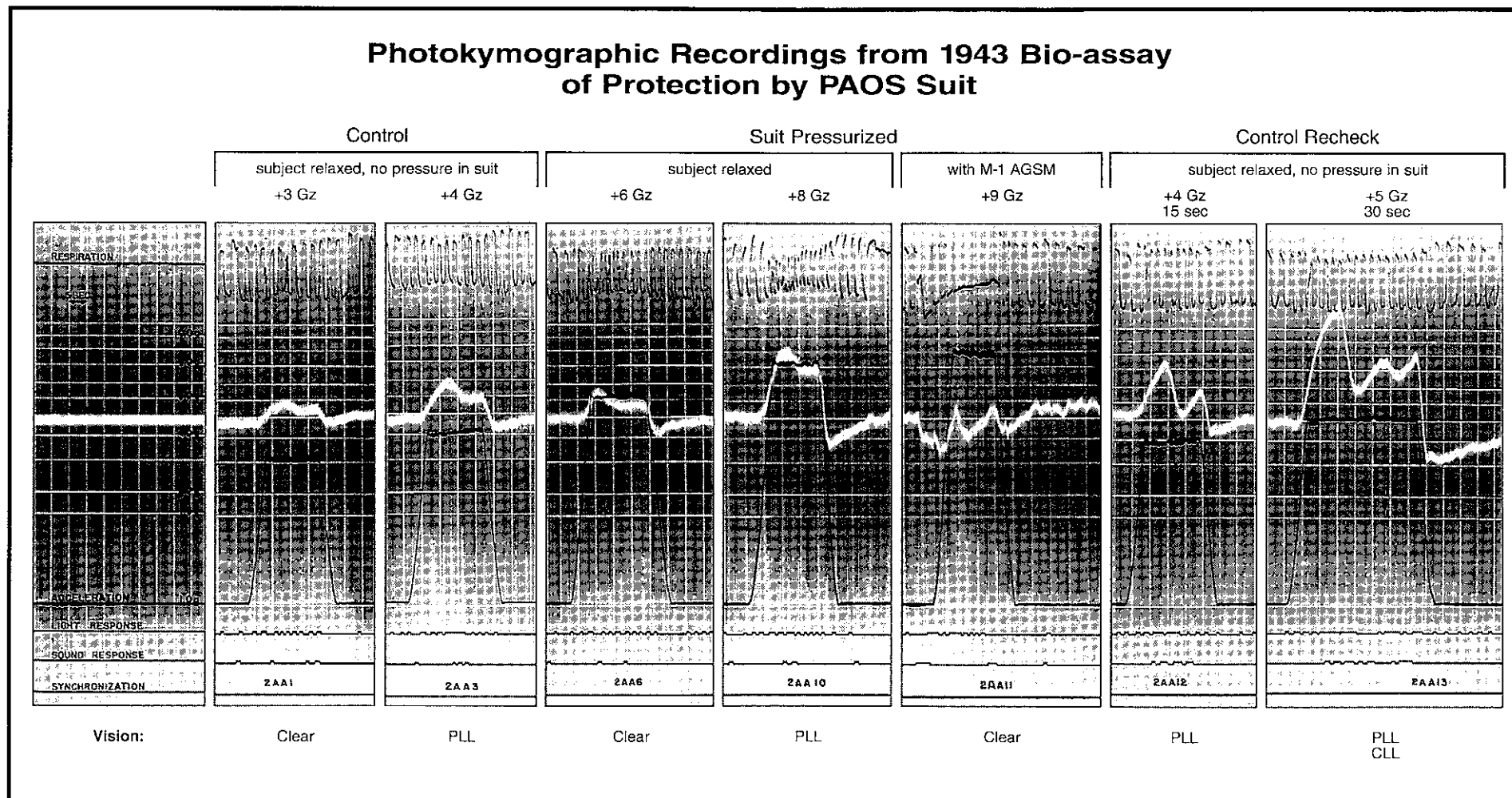

Figure 6. Reduced decrease (deflection) in ear opacity with Progressive Arterial Occlusion Suit.

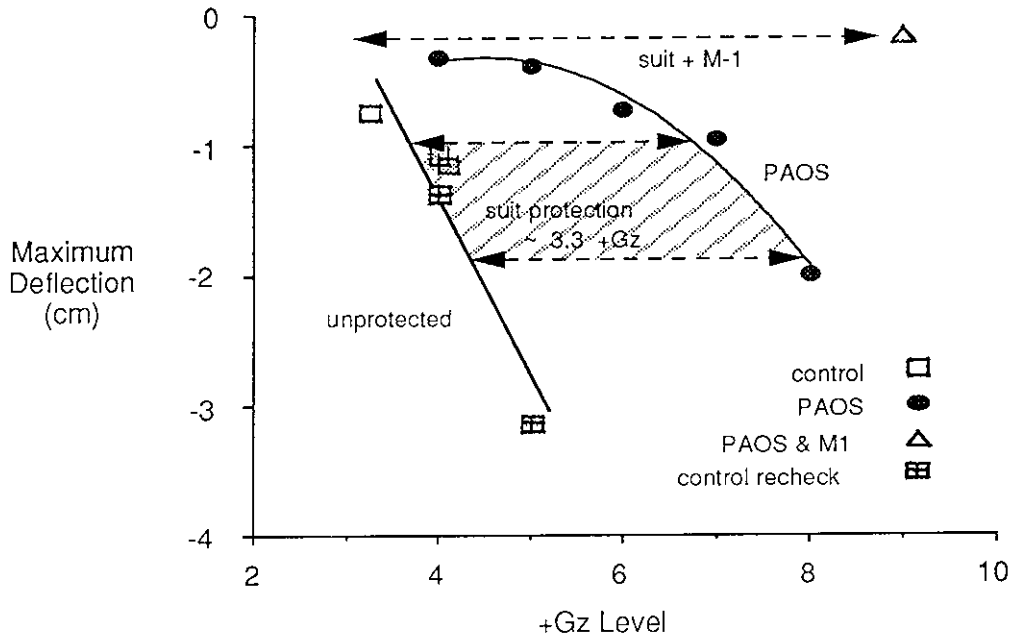

Figure 7. Variation in blood content at ear level at 5s mark of exposure to different plateau +Gz levels without and with standard 5-bladder G-suit.

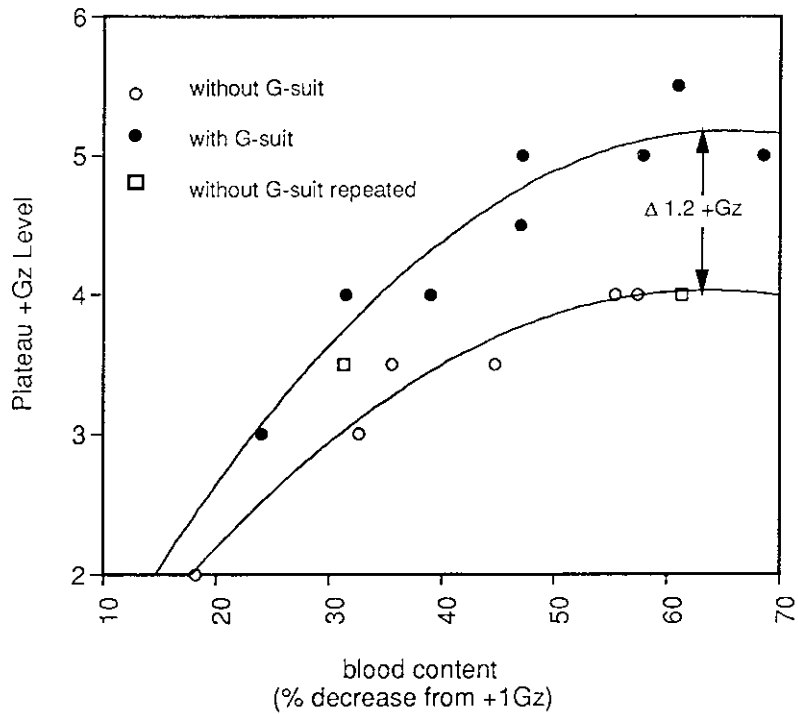

Figure 8. Delayed decrement in ear pulse reduction with standard five-bladder G-suit at different +Gz levels.

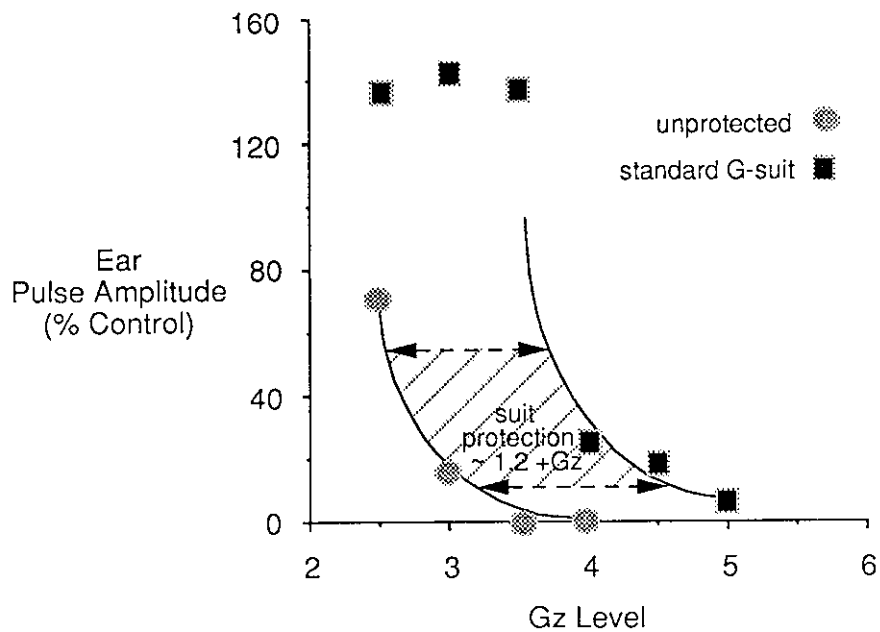

Figure 9. Video monitor view of relaxed and conscious subject using extended coverage G-suit and PBG in DCIEM Centrifuge.

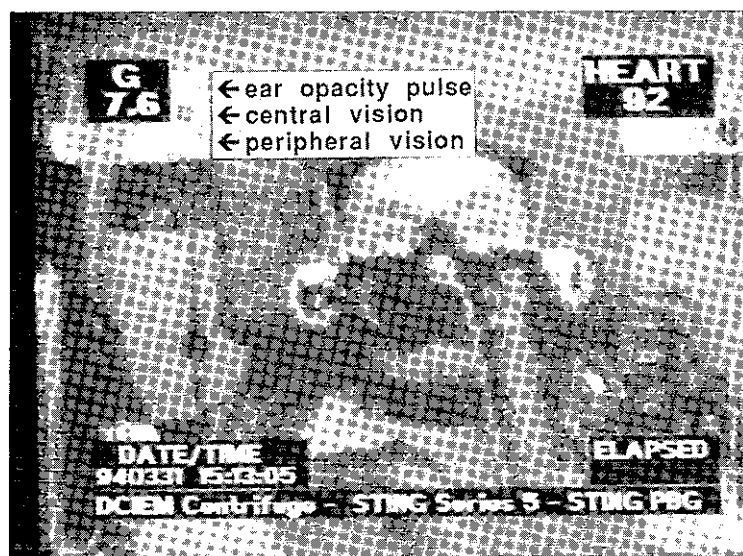

Figure 10. Physiological record of relaxed human subject during exposure to +7Gz protected by positive pressure breathing and extended coverage G-suit, and maintaining peripheral and central vision.

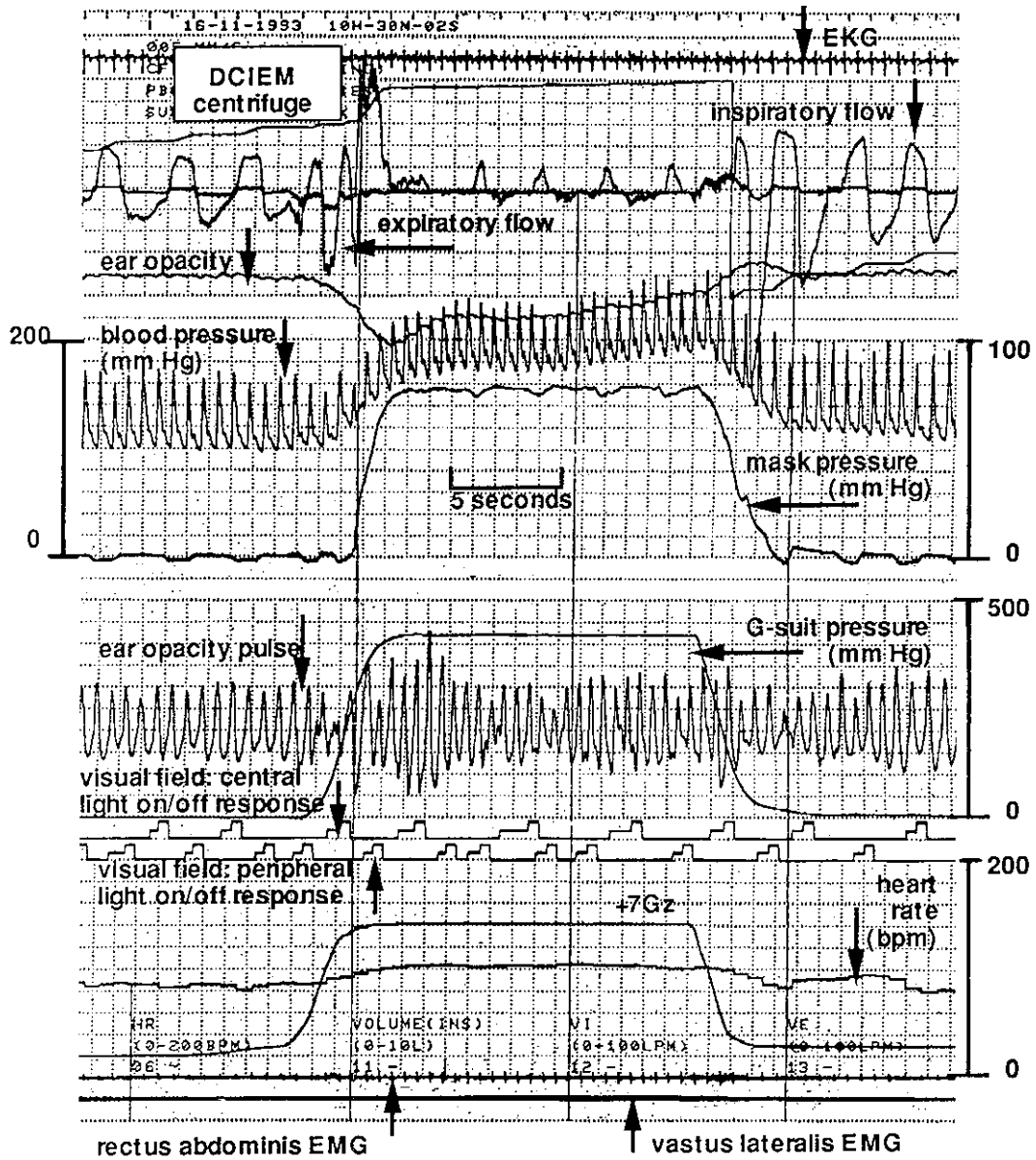
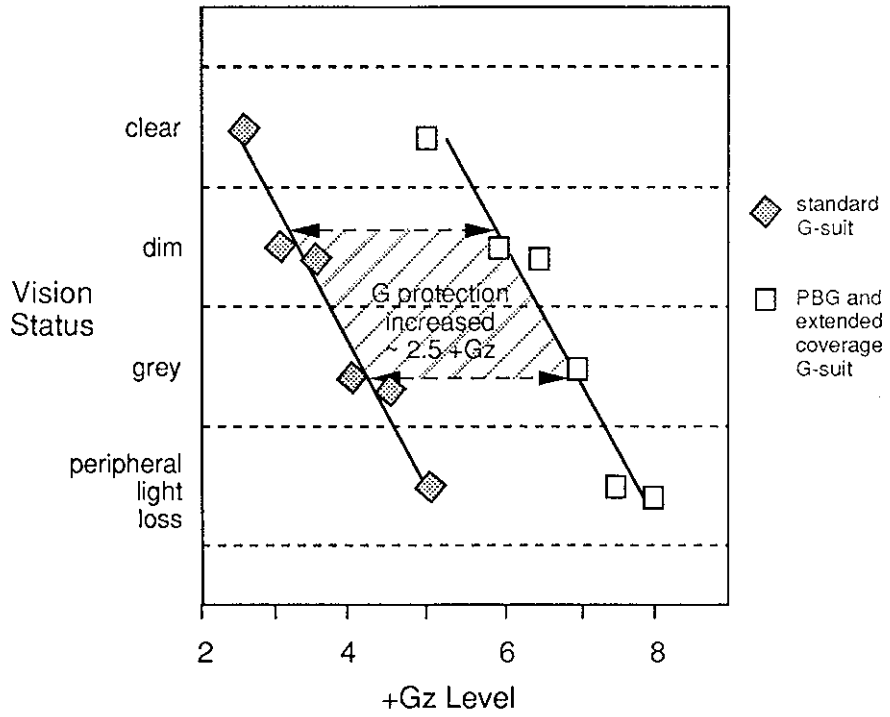

Figure 11. Graph of improved peripheral vision status with positive pressure breathing and extended coverage G-suit.





Selection and Training of MiG-29 and Future Fighter Pilots

Col. MC Dr. H. Welsch

German Air Force Institute of Aviation Medicine*
 Head of Department II - Aerospace Physiology -
 Koenigsbrueck, Germany

SUMMARY

With the reunification in October 3rd in 1990 the German Air Force took possession of not only 24 MiG-29 modern fighter aircraft, but also of the human centrifuge at Koenigsbrueck near Dresden, Saxony. Until now the MiG-29 is the only high performance fighter aircraft of the German Air Force, whose pilots need a training in a human centrifuge in accordance with the STANAG 3827. The Office of the Surgeon General GAF took the occasion to generate a new basic program for the German Air Force not only for the few pilots of the MiG-29, but for the future fighter pilot generation. The program includes the preselection of young pilot candidates on a voluntary basis, to exclude candidates without normal physiological cardiovascular reflexes against acceleration forces, the training for student pilots of fighter aircraft before starting fighter pilot school, and the training and qualification program for fighter pilots, flying or be designed to fly the MiG-29 fighter aircraft or other high performance aircraft such as F-16, F-18, and Mirage 2000 as exchange pilots in the USAF, the CAF, or in France.

INTRODUCTION

Until October 1990 the German Air Force had the human centrifuge of the GAF Institute of Aviation Medicine at Fuerstenfeldbruck at its disposal. Pilot candidates of the GAF officers school at Fuerstenfeldbruck could ride the centrifuge during there physiological training on a voluntary basis. There was no need for GAF pilots to undergo a regular acceleration training, because the fighter aircraft of the GAF - the F-4F „Phantom“, in service now about 30 years, was flown over all the years without a special g-training on a human centrifuge. Other aircraft of the GAF, such as the Alpha-Jet or the PA-200 „Tornado“ are not dedicated for air

combat missions, nevertheless the Alpha-Jet, primarily designed as a training-aircraft, is capable of a lot „g“. Therefore the human centrifuge at Fuerstenfeldbruck was used most the time for training of foreign nation pilots. In addition, this centrifuge was also used for some experimental trials.

The demand of the use of a human centrifuge became more urgent for the GAF during the preparation phase for the fighter pilot generation of the European Fighter Aircraft respectively the European Fighter 2000, or other high performance fighter aircraft of the next generation, superseding the gray „Phantom“. Plans of an upgrade of the human centrifuge at Fuerstenfeldbruck respectively the definition of the technical needs of a new centrifuge were just nearly completed, when the reunification of both parts of Germany happened on October 3rd 1990. The decision was made to safe the human centrifuge at Koenigsbrueck and to disassemble the human centrifuge at Fuerstenfeldbruck for two reasons: First, the human centrifuge at Fuerstenfeldbruck has ended its life circle and would have needed an expensive upgrade, secondly the human centrifuge at Koenigsbrueck, in service since 1986, has a guaranteed working life of 20 years, that means until the year 2006. Following this decision, the building of the former human centrifuge at Fuerstenfeldbruck now is used for the G-LAB disorientation demonstrator respectively disorientation trainer.

For the human centrifuge at Koenigsbrueck in the end of 1992 a new concept was developed with respect of the necessity of a human centrifuge aided acceleration training of the future fighter pilot generation. This concept includes diagnostic centrifuge runs for selection, training for G-inexperienced student pilots, and special training and qualification runs for pilots of modern high performance fighter aircraft.

* Director: BrigGen MC Dr. F.-J. Daumann

GENERAL DESCRIPTION OF THE HUMAN CENTRIFUGE (HC) AT KOENIGSBRUECK

General

The human centrifuge at Koenigsbrueck was constructed by AMST, a consortium in Austria, and went into service in 1986. The use of HC happens first of all for medical evaluation, screening and training of pilots and student-pilots, but makes it also possible to test equipment and material under high-G-conditions. For medical evaluation, screening and training of pilots and student-pilots the HC has a gondola, whose center of gravity is situated in a distance of 10 meters from the main-rotation-axis. To change the direction of the resultant acceleration-vector for the pilot the gondola can execute rotations around two axis. This so called roll and pitch motions of the gondola will be done by hydraulic-motors. For test of equipment and material the gondola may be changed with a material-platform, at which this system in contrast to the gondola can't execute roll and pitch motions.

To obtain physiological data of the pilot and for safety reasons the HC is equipped with an advanced medical monitoring system. Pre-amplifiers for all biomedical monitoring devices are located in the gondola. Signals are fed from the gondola via slip rings to the monitoring devices, which are located in the control room of the HC.

Performance Characteristics

The following is an overview of the performance characteristics of the HC:

Maximum acceleration

- with the gondola: 12 G
- with the material-platform: 40 G

Maximum G-onset rate: 5 G/sec.

Acceleration-limits for the resultant vector:
 (by using the gondola)

$-12 \text{ G} < G_x < +12 \text{ G}$

$-6 \text{ G} < G_y < +4.9 \text{ G}$

$-3 \text{ G} < G_z < +12 \text{ G}$

- Roll motion range: -90 to 135 degrees
- Roll angular velocity range: ± 1.2 radians/sec.²
- Roll angular acceleration range: ± 1.2 rad/ sec.²

- Pitch motion range: ± 90 degrees
- Pitch angular velocity range: ± 1.0 radians/sec.

Pitch angular acceleration range: ± 1.0 radians/sec.²

Variation in roll and pitch angle after reaching steady state: ± 1 degree

Payload capacity

- with the gondola: 200 kg
- with the material-platform: 150 kg

System Components

The seat in the gondola is specially designed to accommodate medical evaluation and training also. The seat has a powered up/down adjustment mechanism, operated from a switch in the gondola. Foot pedals, arm, and the head restraints are adjustable by electrical motors also. In the case of an actual emergency, easy and quick access to the pilot is essential. Many centrifuges are designed for access through the top of the gondola. On the HC at Koenigsbrueck the seat can be tilted downwards out of the gondola. The seat is then in a supine position, which places the head close to heart level for better recovery and examination.

For active training with the HC a control stick and a throttle are installed in the gondola. Further on it is possible to use two one-key-keyboards (installed on the right and left arm), a ten-key-keyboard and a joy-stick. The one-key-keyboard on the left arm or the switch located on the control stick can be used as a "dead-man" control. A Gz-meter and an indicator for the rotation-velocity are installed in the gondola also.

The anti-G-suit pressure supply is realized by an air compressor outside of the gondola. This air compressor is also used for the air ventilation in the gondola. Two anti-G-valves are installed in the gondola, the anti-G-valve from the MiG-29 and the anti-G-valve from the Alpha-Jet. Both anti-G-valves have a press-to-test button to check suit inflation. The oxygen supply system is realized with two 4 liter bottles, which are located on the back of the seat.

An open microphone located in the gondola allows vocal communication with the pilot. An loud-speaker is also positioned in the gondola to allow the pilot to hear the instructor and/or physician. This arrangement allows continuous, hands-free communication between the gondola and the control room. Two video cameras located in the gondola can be used for visual control. The medical monitoring system is one of the most exciting parts of the HC, which provides extensive physiological monitoring during manned

centrifuge operations. It is used to gather research data and to ensure the safety of the pilot. Signals from the medical monitoring devices are recorded by pre-amplifiers which are installed in the gondola. For the data transfer from the gondola to the control room a PCM-system with 16 channels is used. The following physiological parameters may be recorded:

- Electrocardiogram (ECG), a cardiometer is built into the ECG unit in the control room,
- Electroencephalogram (EEG),
- Electromyogram (EMG),
- Electronystagmogram (ENG),
- Blood Pressure,
- Peripheral Pulse Curve from the ear,
- Blood Velocity, measured with a Doppler Flowmeter,
- Respiration (rate and volume),
- Concentration of oxygen and carbon dioxide in the respiration air.

All this parameters can be stored on magnetic tape and on the medical computer.

Control System and Acceleration Profiles

The HC can be operated in three different modes. In the first mode, the manual control mode (MM), the operator manually inputs with potentiometers the parameters for the centrifuge run. In this mode, the operator initiates the start and stop of the centrifuge. The MM is used for maintenance and inspection of the HC.

In the second mode, called the automatic mode (AM), pre-programmed acceleration profiles are used for automatic HC-runs. This accomplishes two advantages:

- the pilot is provided with precisely the same stimulation at exactly the same G-level, when the same profile is selected and/or run again and
- provides accurate, repeatable runs between different pilots for identical profiles.

Finally, the pilot control mode (PM) allows the operator to use a pre-programmed parameter field, which set the maximum conditions, and provides a varying target on the monitor in the gondola. The pilot initiates the onset, offset and G-level, according to his control stick motions. During this mode of control, the pilot essentially has control of the onset, offset, and G-levels of the HC within the limits set by the selected parameter field.

A G-profile for the AM consists of a lot of support-points for each drive system of the HC. For accurate runs it is necessary that the interval of time between two support-points is not greater than 20 ms. The duration of time for one G-profile is selectable and can reach values up to 20 minutes. But on the control computer not all the support-points must be stored. Only this points are stored, which are necessary to recover the exactly G-profile. The other points will determine by interpolation before the HC starts.

In the PM the complete parameter field is stored on the control computer. Such a parameter field consists of

- the selected control element
- maximum G-level
- maximum onset and offset-rate
- the basic acceleration level and
- maximum duration of time of the run.

The flight path of the target is generated by another computer system.

SELECTION AND TRAINING

The common objective of screening, selection, examination, and especially training with the HC is to ensure, that both the candidate and the examiner get information about the individual actual acceleration tolerance and the conclusion, what that means in respect of the personal health, pilot career, and flying safety. In this context not fixed hurdles like the STANAG-profile are the most important thing, but the way to reach this goal, if there is any real possibility for the individual to do so. Therefore, not only centrifuge rides were offered at Koenigsbrueck, but always an overview upon the whole acceleration physiology, like aerobic and anaerobic muscle and cardiovascular training, nutrition and life style, and psychological training aids.

Common for each candidate or pilot is the following procedure in the gondola of the HC:

- briefing about acceleration physiology, the effects of acceleration forces to the human organism, especially the cardiovascular system, and the instructions for the actual profile on the HC,
- medical examination including, ECG, blood pressure, oral temperature, and physical examination by the flight surgeon or physiologist before each exposition in the HC,

- at the start and after the end of each profile the candidate or pilot has to answer green diode-light signals, which illuminate stochastically at the peripheral light bar. The interval-time varies between 600 ms and 1200 ms. The reaction time and the faults (the answer must be given between the minimum of 100 ms and a maximum of 1000 ms) were recorded and are useful to compare the situation awareness before and after each run on the HC,
- during evaluation and training the ECG, the ear-pulse, the respiration frequency, the voice communication, and the video signal are monitored and recorded. The reaction time will be measured only during the passive runs (PM). The correct answer in time to the green illuminating diode-light at the light bar in the periphery is a good method to get objective indices of the alertness of the candidate. The light signals will come upon g-levels greater than +1.6 g_z.
- the first typical profiles for each individual on the HC are the warm-up-run profile EP 01 (Fig. 1) and the gradual G-increase profile LP 01 (Fig. 2). These two profiles are realized in the AM and are always the first profiles for each candidate, student-pilot or pilot. This interval-profile EP 01 will give a first impression of the peculiarity of the HC and is a common preparation for the following profile, the determination of the individual natural unprotected G-tolerance with the linear profile LP 01,

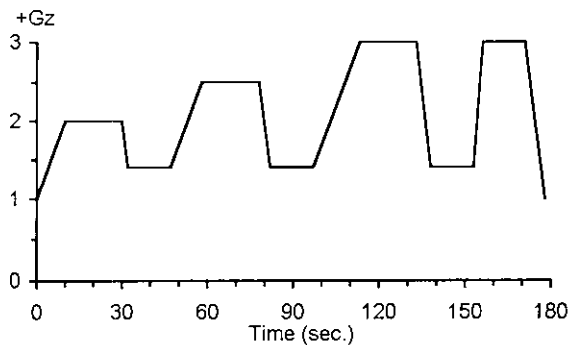

Fig. 1:

warm-up-run profile EP 01:
 first 3 onset: 0.1 gs⁻¹, last onset 0.5 gs⁻¹
 offset: 0.3 gs⁻¹, first 3 plateaus 20 s, last 10 s.

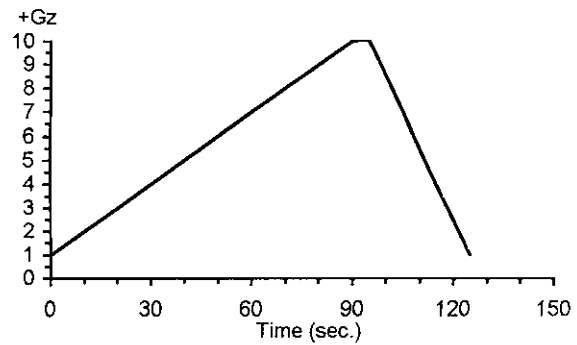

Fig. 2:

linear profile LP 01: gradual onset: 0.1 gs⁻¹
 gradual offset: 0.3 gs⁻¹

- each profile will start on the 1.0 g_z basis, but during the profile itself the lowest G-level remains by 1.4 g_z, the „idling speed“ of the HC. The reason is to reduce further more unnecessary coriolis effects during deceleration,
- the deceleration of the HC after normal and emergency termination of any profile will be -0.3 gs⁻¹, with the experience, that a smoother deceleration is more protective than a rapid deceleration in case of cardiovascular disturbances. The „lost“ time during a smooth deceleration is more valuable than the disadvantage of a rapid deceleration with blood pooling on the right heart side due to the reflux, the decrease of the heart rate, and the additional coriolis effect,
- medical examination including, ECG, blood pressure, and physical examination by the flight surgeon or physiologist after each exposition in the HC,
- individual debriefing.

Each profile may be terminated either by the candidate in the gondola himself by releasing the stick or releasing the „dead mans button“, or by the medical responsible physician at the medical monitor console, or the chief engineer. There is altogether a fourfold redundancy for safety reasons.

Natural G-tolerance of pilot candidates

During the first examination of pilot candidates in the GAF Institute of Aviation Medicine at Fuerstenfeldbruck physiological and psychological clinical methods are used for the decision, if the candidate is physically and mentally healthy to

start a pilots career. The special qualification for operations in a high-g environment cannot be developed with common clinical methods. Therefore the examination of the natural, that means „relaxed, passive“ G-tolerance might be an additional item to select especially qualified young candidates for the career in a high performance fighter aircraft.

The examination includes:

- briefing about acceleration physiology, the effects of acceleration forces to the human organism, especially the cardiovascular system, and the instructions for the passive evaluation in the HC,
- starting with a „warm-up“ interval-profile EP 01 (Fig. 1),
- followed by the linear profile LP 01 (Fig. 2) with an gradual onset of 0.1 gs^{-1} ,
- determination of the natural g-tolerance by using either the individual symptoms answered verbal by the candidate (grayout, tunnelvision), or monitored symptoms like depression of the ear pulse curve, more than two wrong (e.g. inadequate) reactions upon the light diodes, or typical visual findings on the video monitor.

There is neither active nor passive anti-G-protection.

The evaluation includes the following criteria:

- natural G tolerance:

3.5 to 3.9 g_z :	2 points
4.0 to 4.6 g_z :	4 points
> 4.6 g_z :	6 points
- heart rate during the preparation phase (during the time, when answering the light signals before starting the first profile):

> 120 s^{-1} :	0 points
100 to 119 s^{-1} :	1 points
80 to 99 s^{-1} :	2 points
60 to 79 s^{-1} :	3 points
- heart rate at the end of the 3 g_z plateau during the warm-up run profile:

> 160 s^{-1} :	0 points
140 to 159 s^{-1} :	1 points
120 to 139 s^{-1} :	2 points
100 to 119 s^{-1} :	3 points

The qualification result will be:

less qualified:	< 5 points
qualified:	6 to 8 points
especially qualified:	9 to 12 points

The qualification results of the voluntary, since May until December 1994 „ranked“ 97 candidates:

less qualified:	7
qualified:	49
especially qualified:	41

This qualification result however will be only an additional value for the screening method to get a new fighter pilot generation. We expect to get information of the usefulness of this evaluation perhaps after five to ten years, when the candidates are licensed pilots. We know very well, that g-tolerance measurements in the early phase of the pilot career will not be able to predict the qualification of an excellent fighter pilot. But we think, that even the finding, that one individual seems to be really not qualified for the high-g environment, the candidate will use this finding to choose an alternative profession, or a pilot career with a transport aircraft.

Training of student pilots

Before starting the pilot school in the USA the young, G-inexperienced student pilots and students for the weapon system officers school join the G-training course on the HC at Koenigsbrueck. Their flight experience is about 18 to 20 flying hours on the Beech Bonanza F 33 lightweight aircraft during their screening period in Goodyear, Arizona. The first course started in November 1993, the last course exclusive for the G-training ended in February 1995. Since March 1995 the G-training is an integrated part of the one-week physiological training course at Koenigsbrueck.

The objective of this course is, that the students become familiar with the G-environment. They should learn to perform active maneuvers to increase their G-tolerance, thus the effectiveness of muscle straining maneuvers and especially of the correct breathing technique, they should learn, how effective the anti-G equipment works, they should get the impression, how to avoid G-LOC, and they might get the impression and experience of G-LOC.

The training program consists of:

- briefing about acceleration physiology, the effects of acceleration forces to the human organism, especially the cardiovascular system, and the instructions for the first passive evaluation in the HC,
- starting with the „warm-up“ interval-profile EP 01 (Fig. 1), no anti-G equipment,

- followed by the linear profile LP 01 (Fig. 2) with a gradual onset of 0.1 gs^{-1} , no anti-G equipment, to determine the individual natural G-tolerance.
- Theory and exercise of muscular anti-G straining technique and anti-G breathing technique, supported by a breathing monitor device, is the step, before the student will practice these techniques - equipped and supported by anti-G-trousers - during sustained G-profile of about 40 to 60 seconds duration.
- The individual relaxed G-tolerance will be the clue for the following active and passive training profiles. To increase the effectiveness of a short training course and to avoid unnecessary G-LOC without any training effect, the following profiles will be limited to a maximum G-level of 4.0 g_z to 6.0 g_z . The reason is, that the students should stay on the borderline between their individual G-tolerance and the optimal G-level for the special task, they have to fulfill during the following profiles.
- The first training profile is an active trapezoid profile (PM), no anti-G-trousers. The G-level will be normally limited to 4.0 g_z . The G-level should be high enough, that without an accurate breathing maneuver G-LOC may occur due to the long duration of the profile, but which is low enough, that the student may learn, how easily and effective the grayout can be terminated by adequate active anti-G maneuvers.
- The next profile is a passive interval profile (AM), consisting of three plateaus of 3.5 g_z followed by three plateaus of 4.0 g_z (TP1A: Fig. 3) in the minimal version and three plateaus of 5.0 g_z followed by three plateaus of 5.5 g_z (TPID: Fig. 4) in the maximum version.

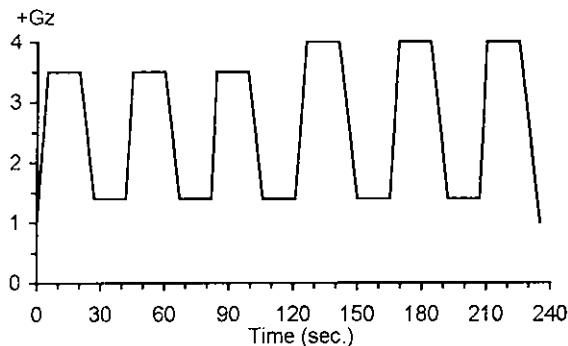

Fig. 3:
 minimum level interval training profile TP 1A:
 first 3 plateaus 3.5 g_z , second 3 plateaus 4.0 g_z ,
 onset: 0.5 gs^{-1} , 0.7 gs^{-1} , 1.0 gs^{-1} , offset 0.3 gs^{-1} ,
 plateau duration 15 seconds.

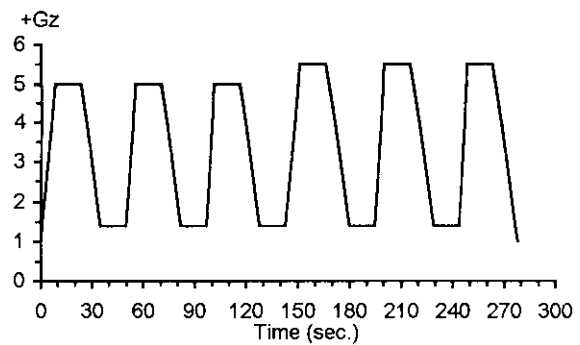

Fig. 4:
 maximum level interval training profile TP ID:
 first 3 plateaus 5.0 g_z , second 3 plateaus 5.5 g_z ,
 onset: 0.5 gs^{-1} , 0.7 gs^{-1} , 1.0 gs^{-1} , offset 0.3 gs^{-1} ,
 plateau duration 15 seconds

The onsets up to the plateaus are 0.5 gs^{-1} , 0.7 gs^{-1} , and 1.0 gs^{-1} respectively. The duration of each plateau is 15 seconds. This interval profile should improve the technique of straining and breathing maneuvers. The students wear proper fitted anti-G-trousers.

- The next profile is an active interval profile (PM), consisting of four plateaus with an increasing G-level of 3.0 g_z , 3.5 g_z , 4.0 g_z , and 4.5 g_z (AV 03: Fig. 5). After this pretence the student is then instructed to perform g-profiles of his own with different G-onsets and G-levels. The maximum G-level is 4.5 g_z in the minimum version (profile AS 06) and 7.0 g_z in the maximum version of this active profile (profile AS 11). The anti-G-trousers will be worn.

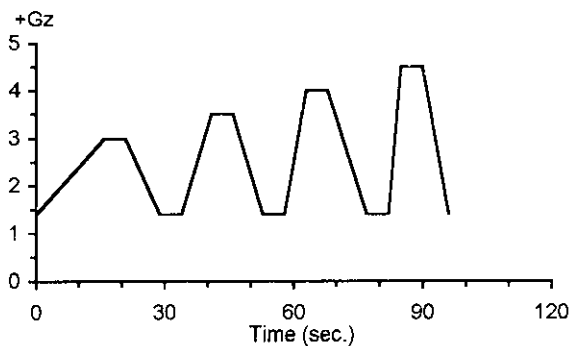

Fig. 5:
 active training profile: pretence - profile AV 03

1st plateau 3.0 g_z , onset: 0.1 gs^{-1} , offset 0.3 gs^{-1} ,
 2nd plateau 3.5 g_z , onset: 0.3 gs^{-1} , offset 0.3 gs^{-1} ,
 3rd plateau 4.0 g_z , onset: 0.5 gs^{-1} , offset 0.3 gs^{-1} ,
 4th plateau 4.5 g_z , onset: 1.0 gs^{-1} , offset 0.3 gs^{-1} .
 Plateau duration 15 seconds.

After this pretence: active free maneuvering up to 4.5 g_z (profile AS 06) or up to 7.0 g_z (profile AS 11).

- The last and qualification profile is the passive linear profile LP 01. To document the result and the effort of the training the student should perform the anti-G-manuevers in the following procedure:

First: The student should stay relaxed until he get the first impressions of beginning grayout symptoms. This point will be announced by the word „now“ by the student. On „now“ he starts the muscular straining maneuver. This actual G-level will be documented and denominated as the first peripheral light loss (1.PLL).

Second: When the student get the second time his beginning grayout symptoms during his muscular straining phase he takes a deep breath and begins with the anti-G-breathing maneuver. This actual G-level also will be documented and denominated as the second peripheral light loss (2.PLL).

Third: When the student get the third time his beginning grayout symptoms he should terminate his run voluntary by releasing the „dead man“ button: Termination by the student. Most the times the profile will be terminated by the instructor however due to typical objective indications, thus as depressed ear pulse curve, inadequate or missing answers to the diode-light signals, exceeding the limit of the maximum heart rate, or passing the G-level of 7.0 g_z. This maximum G-level is chosen as safety limit to avoid unnecessary risks, because the lower body of the student isn't protected by anti-G-trousers.

7.0 g_z should be enough for the first attempt.

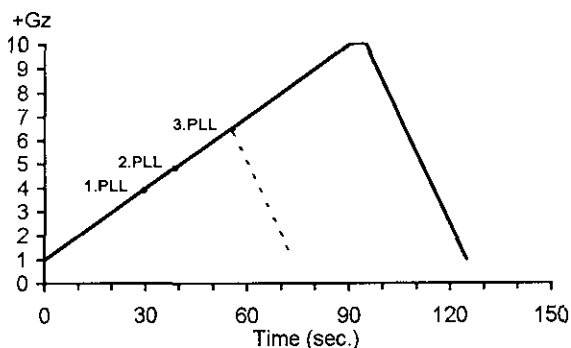

Fig. 6:

qualification profile

linear profile LP 01: gradual onset: 0.1 gs⁻¹
 gradual offset: 0.3 gs⁻¹

1. PLL: relaxed G-tolerance, no anti-G-manuevers
2. PLL: G-tolerance increased by muscular straining maneuvers
3. PLL: G-tolerance increased by additional anti-G-breathing maneuvers

The qualification results of the first 66 students:

1. PLL: 3.90 g_z ± 0.45 g_z (2.9 4.9 g_z)
2. PLL: 4.94 g_z ± 0.55 g_z (3.7 6.3 g_z)
3. PLL: 6.45 g_z ± 0.55 g_z (4.9 7.4 g_z)

This indicates, that the muscular straining maneuver will increase the G-tolerance by about 1.0 g_z, and the additional breathing maneuver will increase the G-

tolerance by another 1.5 g_z. On an average of 2.5 g_z the G-tolerance will be increased by both techniques even under worse conditions: the student has his first training of the technique, there are only 2 days of training, and the operational in-flight anti-G-technique is not used, thus as starting straining and breathing maneuvers simultaneous at the first beginning of the acceleration exposure to avoid blood pooling in the lower body compartment in the early phase of the acceleration exposure.

Training of MiG-29 pilots

The training or qualification program of pilots with G-experience uses most of the above described profiles, thus the EP 01 (Fig. 1), the LP 01 (Fig. 2), the active profile AV 03 (Fig. 3) with the following profile AS 11 (limitation: 7.0 g_z). He will wear his own anti-G-trousers, connected to the anti-G-valve after determination of the actual relaxed G-tolerance. Normally the aim of the qualification program is the performance of the STANAG profile ST 01 (Fig. 7). The pilot has the opportunity to perform this qualification profile by preparation of himself with some „warm-up“ maneuvers like in an actual air combat scenario. He has to reach the 7.0 g_z-level plateau with the minimum duration of 20 seconds and the minimum onset of 1.0 gs⁻¹ by pulling back the control stick rapidly to his stomach. This maneuver has to start on the 1.4 g_z idling G-level.

STANAG-profile :

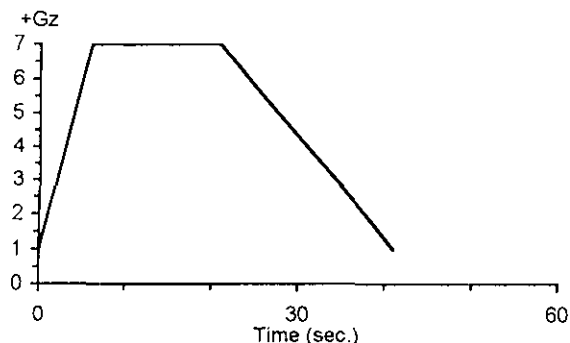

Fig. 7:

qualification profile ST 01 (STANAG 3827):

- g-onset: $> 1.0 \text{ gs}^{-1}$
- plateau duration: $> 15 \text{ s}$
- gradual offset: 0.3 gs^{-1}

In the high-G training program the pilot may perform typical simulated Air Combat Maneuver Training Profiles (ACMTP) from the weapon system MiG-29 and other high performance aircraft.

For this simulation a special method was developed, which used the original data from the flight recorder. So it is possible to provide a very realistic training for the pilots. Such profiles are realized in the automatic mode (AM). The reason for the AM is, that the installed software is not fast enough to simulate adequate reactions of the gondola speed to the stick inputs in a high dynamic environment. The delay time due to the calculation time of the analog steering mode would be not realistic and would produce pilot induced oscillations.

The disadvantage of the automatic mode AM by using ACMTPs is that the pilot is not able to foresee the lapse of the profile and so the possibility consists that the pilot is surprised by high G-onset rates and high G-levels and G-LOC may occur. Therefore we use the display in the gondola for information about the actual and the following flight parameters as shown on Fig. 8:

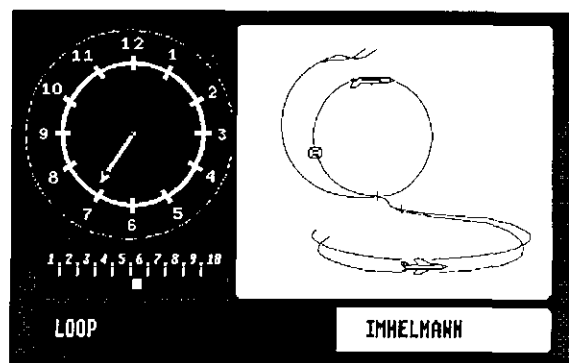

Fig. 8: Visual display layout for ACMTP in the automatic mode (AM)

On the right hand side the actual flight figure is shown as graphical presentation with a cursor which shows the actual position in the flight figure. On the left hand side a G-level indicator and a scale with all numbers of the flight figures of the profile are simulated. Here shows a cursor the actual flight figure. At the bottom the actual and the next flight figure as written text are displayed.

It is no question, that the better training is the active training in the pilot control mode: visual scene like in the aircraft with the target aircraft in the front.

In the pilot control mode (PM) the HC at Koenigsbrueck has two possibilities for using the display in the gondola:

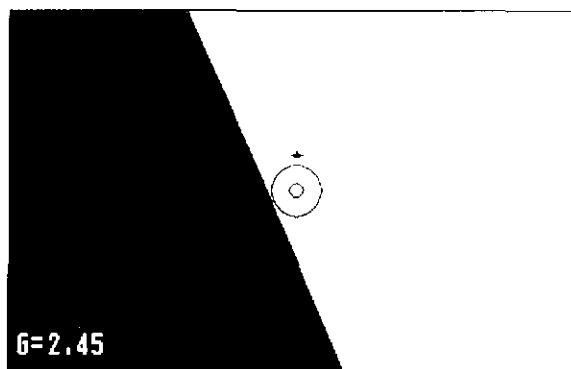

Fig. 9: simulated artificial horizon and target

The display (Fig. 9) shows the horizon which shall rotate at an angle equal to the roll angle. The target symbol shall start at the center of the display and shall move proportionally on the display to show the error between the G-level commanded in the target file and that commanded by the pilot.

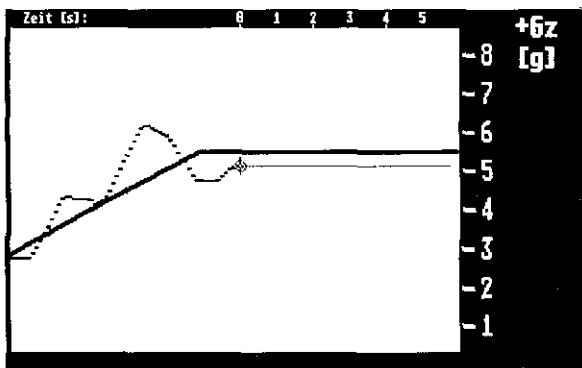

Fig. 10: coming up G-level indication

The display (Fig. 10) shows a curve which moves from right to left and displays the G-level of the target. The G-level commanded by the pilot is also displayed in a dotted line. The difference between both curves is the error.

Both display modes in the PM are very simple.

Upgrade of the HC at Koenigsbrueck

The upgrades of the HC would be accomplished to adapt the centrifuge for simulation of NATO-specific tactical fighter aircraft to improve the realism and effectiveness of training in air combat *maneuvering and weapons system use*. The main part of such an upgrade is an interactive control system, which has the following components:

- Visual System,
- Aircraft Instrument Simulation,
- Aircraft-Specific Aeromodels,
- new Computer Control System.

Two visual systems are for flight simulation and target tracking. They consist of visual displays and image generating computers. The integration of the student's visual system with the control system and simulated flight controls must be so that the visual scene corresponds to the pilot's control inputs and the motion of the HC. For aircraft instrument simulation there may be used a special CRT monitor in the gondola. Simulated instruments are generated by computer and may be arranged to simulate any aircraft configuration. Two special aeromodelling control subsystems may be used to simulate the control and motion response of specific aircraft. The aeromodels calculated flight values are based on the inputs by stick, throttle, and rudder by the student pilot and the instructor. The G-loads G_x , G_y , and G_z are transmitted to the control computer, which converts the values for pitch, roll and yaw motions of the HC.

The second part of the initiated upgrade is the adaptation of aircraft-specific life support systems. So the integration of a pressurized air supply

system to accommodate a variety of anti-G-suit systems, also including PPBG-systems, are mandatory assumptions for future pilot training.

DISCUSSION

The human centrifuge at Koenigsbrueck, primarily constructed for medical research and diagnostic is now in service preponderant for pilot candidate selection and student pilot training. The effort of the student pilot training seems to be one great promising method to prepare the student pilots for the coming-up G-environment. The aim of this training is, to avoid unnecessary G-LOC not only during the pilot school, to produce flying safety, and perhaps to reduce unnecessary mismatch feelings during the first realistic air combat training missions in the T 37 or T 38. Secondly student pilots with uncommon motion sickness problems in the HC (in the HC at Koenigsbrueck less than 0.1 % of centrifuge-runs have to be terminated due to motion sickness, the logical consequence of the 10 m arm of the gondola and the active three degree of freedom gimbal system), poor G-tolerance or even pathologic G-tolerance may be detected early enough, so that first further medical diagnostics should be done, before the expensive pilot school starts. The decision, if a preselection during the training of the student pilot should be done, is under discussion.

Also under discussion is the question, if the up to now voluntary evaluation of the natural G-tolerance of the young pilot candidates should be mandatory. The question, if the results of the evaluation should determine or at least influence the selection of this 18 to 20 year old male population for future qualification for agile fighter aircraft, may be answered perhaps after a period of 5 years. Then the self control of our judgment of today is possible.

The training of our MiG-29 pilots and other pilots, which are designed to fly high performance aircraft seems to be necessary. Although most of the pilots don't have difficulties to reach the qualification of the STANAG-profile, the poor and ineffective anti-G-technique, which needs a lot of wasted energy, shows us, that there was a lack of information on anti-G-techniques to most of the pilots in the past. To get the impression of the effectiveness of optimized anti-G-maneuvers might be one reason to join at least once the G-training course. To get the impression of their own limits and to produce self-confidence by getting on the limits in a safe environment might be also an effective contribution to flying safety.

References:

1. AGARDograph No.322, AMP Working Group
14
High G Physiological Protection Training
December 1990
2. AGARD CP No.516
High Altitude and High Acceleration Protection
for Military Aircrew
October 1991
3. AGARD CP No.396
Medical Selection and Physiological Training
of Future Fighter Aircrew
December 1985
4. Bulbulian R., Crisman RP., Thomas MC.,
Meyer LG:
The effects of strength training and centrifuge
exposure on +Gz tolerance.
Aviat. Space Environ. Med. 1994; 65:
1097-1104
5. Welsch H., Zöllner S., Miosga J.:
Diagnostik, Ausbildung und Forschung in der
Außenstelle der Luftwaffe für Flugmedizin
Flugsicherheit 5/93; 3-12

G-PROTECTION CAPABILITIES AND CURRENT G-PROTECTION ISSUES

JW BURNS

Crew Technology Division
 Armstrong Laboratory
 Brooks AFB TX 78235-5104
 USA

FEMALE +G_z TOLERANCE

With the inclusion of females as pilots of high performance combat aircraft there is a necessity to determine their G tolerance and endurance capabilities, which is a reflection of strength.

Males, as a group, are significantly stronger than females. For hand operated controls the strength of the 5th percentile male is similar to the 50th percentile female (4). Males demonstrated an average 71% greater forces on hand controls and 61% greater foot control forces than females. However, the strength of both males and females can be improved about the same amount with physical conditioning. Weaker individuals benefit the most from physical conditioning programs, whereas, very fit individuals show little improvement. There is a poor correlation (avg. 0.2) between body size and strength within gender. Thus there are some small individuals who are very strong and conversely some large individuals who are relatively weak. Anthropometrically, about 90% of males and 40% of females meet the current size requirements for pilots.

Current +G_z-protective equipment has been designed using male anthropometry. Because of the very distinct anthropometric differences between the male and female, life support equipment fit becomes a critical issue. A properly fitting anti-G suit is necessary for adequate protection during +G_z. A poorly fitting anti-G suit places the female aircrew at increased risk and impacts their ability to optimally perform during high G maneuvering. A recent field survey of female aircrew revealed that 50%

TO MOD

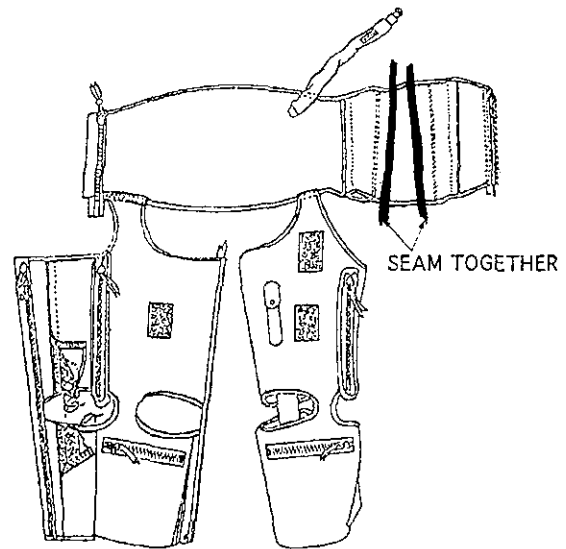

Figure 1. Technical Order (TO) anti-G suit modification allows for circumferential reduction in waist, thigh, and calf.

of the respondents felt that their anti-G suit was too loose in the waist. Moreover, 14% of the respondents experienced lower rib pain or discomfort when the anti-G suit inflated during +G_z (7). The anti-G suit Technical Order (TO) allows for a circumferential reduction in the waist, thigh and calf of the anti-G suit to accommodate smaller personnel (Figure 1). However, TO modifications are not adequate for some females, especially for relief of lower rib cage pain. At Armstrong Laboratory we have added several additional modifications (AL mod.) to provide a "best fit". The additional modifications are: 1) a V-shaped dart in the lumbar restraint material to bring the suit in at the waist; and 2) lower the upper edge of the abdominal bladder below the rib cage in the seated position (Figure

AL MOD

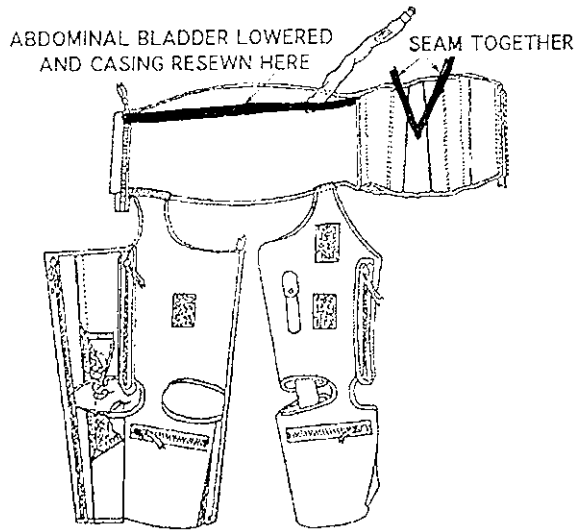

Figure 2. Armstrong Laboratory (AL) anti-G suit modification allows for lowering the abdominal bladder for comfort, and placement of a dart in the lumbar restraint for a better female fit.

SIZE RANGES OF MALES

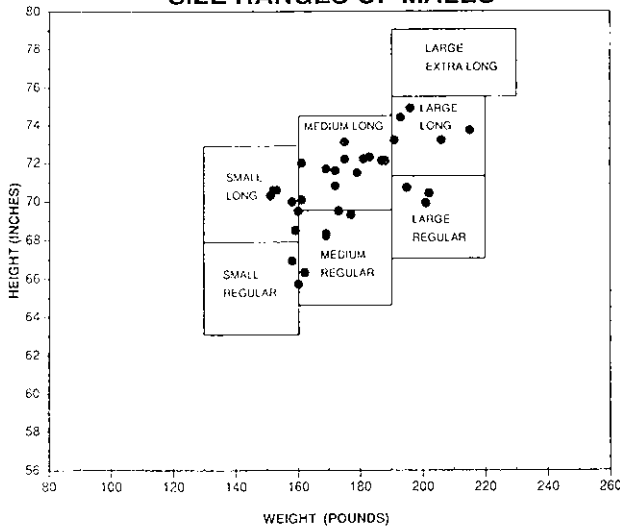

Figure 3. Current male anti-G suit sizes related to weight and height.

2). These two additional modifications have provided a comfortable, effective anti-G suit fit for those females who were not adequately fitted with the TO modification. Figure 3 illustrates the current anti-G suit (CSU-13B/P) sizes designed for males, and

SIZE RANGES OF FEMALES

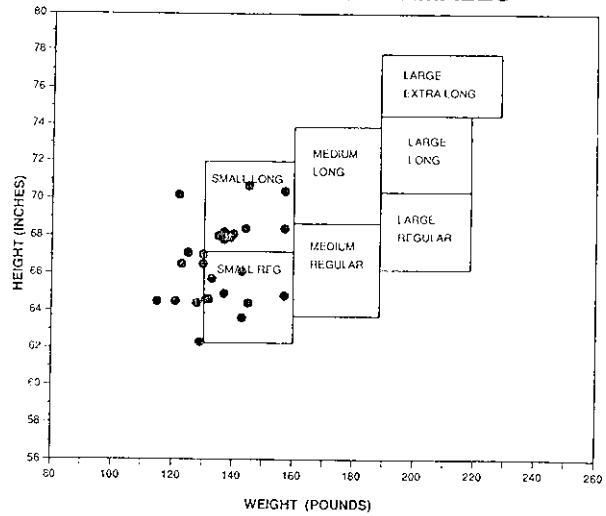

Figure 4. Current male anti-G suit sizes and the scattering of sampled females within those

the scattering of sampled males within those sizes. Figure 4 illustrates the same male sizes as Figure 3 with the scattering of sampled females within those sizes. Twenty seven percent of surveyed female aircrew were below the currently available height and weight anti-G suit size ranges.

To date, two female F-16 pilots have used Armstrong Laboratory facilities for the AL modification to their anti-G suit. One of the female pilots required a reduction of the upper edge of the abdominal bladder by 3 in. and relocation of the air hose inlet by 1/2 in. Both modified anti-G suits were cleared by a formal safe-to-fly board and are now being used operationally by the two female pilots. Armstrong Laboratory has an ongoing program to evaluate the female size requirements for the current CSU-13B/P anti-G suit, as well as pressure breathing chest counterpressure garments and masks (COMBAT EDGE), and an extended coverage anti-G suit now under development. From the size requirements, new patterns will be developed for fabrication and testing of the newly sized anti-G suits and chest counterpressure garments, if necessary.

G-LAYOFF

Anecdotal information has been available for many years suggesting a positive relationship between time away from +G_z exposure (G-layoff) and a reduced G tolerance. However, little empirical data exist to corroborate the observations.

Experienced aircrew frequently report that resumption of high +G_z flying after an extended layoff is accompanied by a period of reduced +G_z tolerance. This effect abates with the resumption of normal flying activity, but is frequently severe enough to be viewed as hazardous. Numerous aircraft and aircrew have been lost during first flights following layoff. Pilots of high performance aircraft are instructed to perform several lower +G_z "warm up" maneuvers early in their mission to check-out the +G_z-protective equipment and get a feel for their G tolerance for that day. Figure 5 is a schematic of factors and kinetics of G-layoff for illness, TDY, PCS, leave, a non-fly-

EFFECT OF LAYOFF ON G TOLERANCE

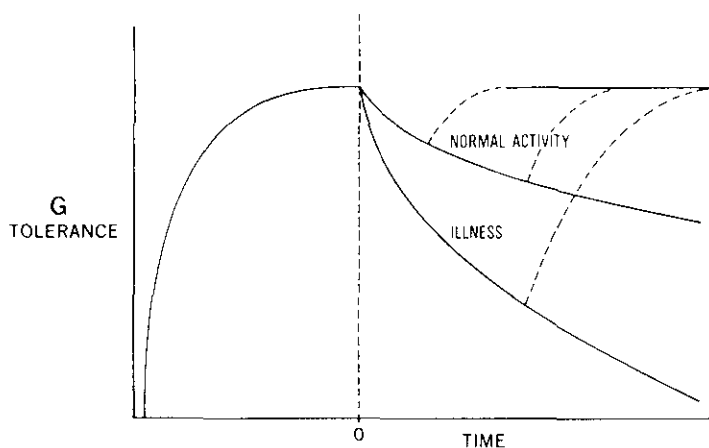

Figure 5. Schematic of G-layoff effects on +G_z tolerance.

ing assignment, etc. There is a finite time and exposure rate to develop an acceptable level of G tolerance (Figure 6) and a finite time to reestablish that level after a layoff. The rate of deterioration and reestablish-

EFFECT OF FREQUENCY OF G EXPOSURE ON G TOLERANCE

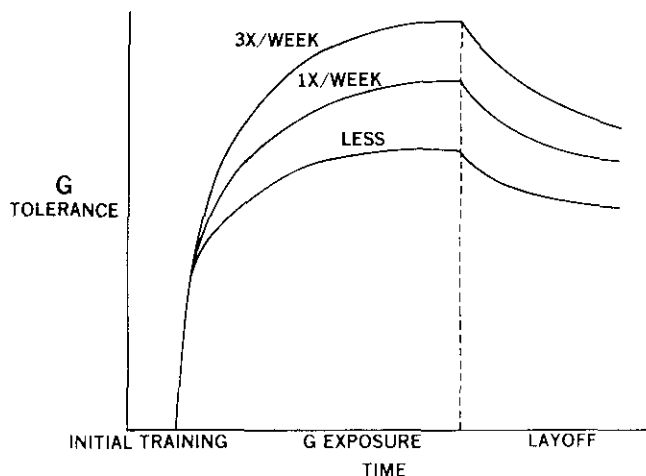
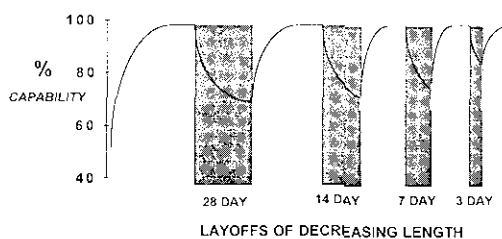

Figure 6. Schematic of frequency of +G_z exposure effects on +G_z tolerance.

ment of G tolerance after a G-layoff is variable from one pilot to another and appears to depend upon the physical activity of the pilot. Those pilots who maintain an active weight lifting program seem more likely to maintain their G tolerance for a longer period of time during a G-layoff (slower decay rate).

Following a recent suspected G-layoff related loss of aircraft and pilot due to G-LOC we were requested by the USAF Air Combat Command (ACC) to experimental-

DESIGN STRATEGY



CONDITION EACH SUBJECT TO FULL CAPABILITY, THEN LAYOFF, RECONDITION, AND GIVE SHORTER BREAKS UNTIL EFFECT IS LOST.

Figure 7. Design strategy to investigate G-layoff effects.

SACM ENDURANCE FINDINGS
 (28 DAY LAYOFF)

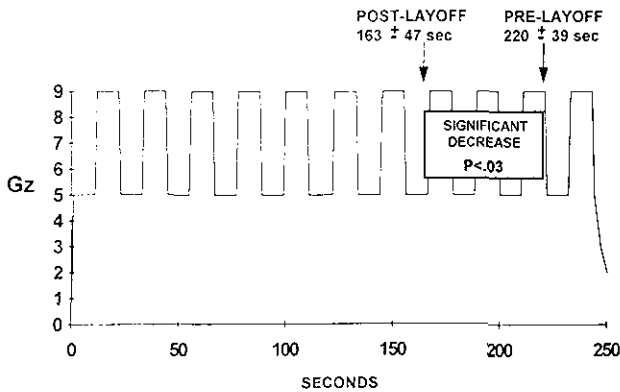

Figure 8. Results of 28 day layoff from +Gz.

ly investigate the relationship between G-layoff and +G_z tolerance. Eight volunteer centrifuge subjects were trained to consistent performance using a rigorous +G_z exposure regimen (+5 to +9G_z simulated aerial combat maneuver, SACM) twice weekly to exhaustion, followed by a 28 day layoff from +G_z (Figure 7). The subjects relaxed gradual, and rapid onset +G_z tolerance, and endurance during the +5 to +9G_z SACM were monitored, as well as their aerobic and anaerobic exercise capacities, before and after the 28 day G-layoff period. Relaxed gradual and rapid onset tolerance appeared unchanged by layoff, but endurance during the +5 to +9G_z SACM was significantly reduced from 220 sec to 163 sec (Figure 8) by layoff (p<.03). No differences were apparent in pre- or post-layoff aerobic or anaerobic capacities. The reduced endurance observed in this study may reflect the reduced +G_z tolerance reported to follow prolonged interruptions to a normal flying schedule, but they are not related to changes in aerobic or anaerobic metabolism, or relaxed responses to +G_z. This study has been extended to include a 14 day lay-off period with similar findings (5).

The AGSM is a major factor in the mainte-

nance of vision and consciousness for most pilots during high levels of +G_z. Loss of AGSM proficiency is a contributing factor to G-LOC. The AGSM should be automatic and come naturally during +G_z so as not to interfere with optimum aircrew performance during critical combat maneuvering. Thus, to regain proficiency after G-layoff, it is necessary to perform non-critical "tune-up" sorties to provide the aircrew an opportunity to re-establish AGSM proficiency before demanding sorties.

+G_z-INDUCED LOSS OF CONSCIOUSNESS (G-LOC)

Over the years a significant loss of aircraft and life have been attributed to G-LOC. Human-based centrifuge research to reduce the incidence of G-LOC has resulted in the development of several pieces of +G_z-protective equipment or techniques such as an extended coverage anti-G suit (ECGS), the anti-G straining maneuver (AGSM), tilt-back seats, and positive pressure breathing during +G_z (PBG). These equipment or techniques, used alone, or in combination,

G-TIME TOLERANCE CURVE

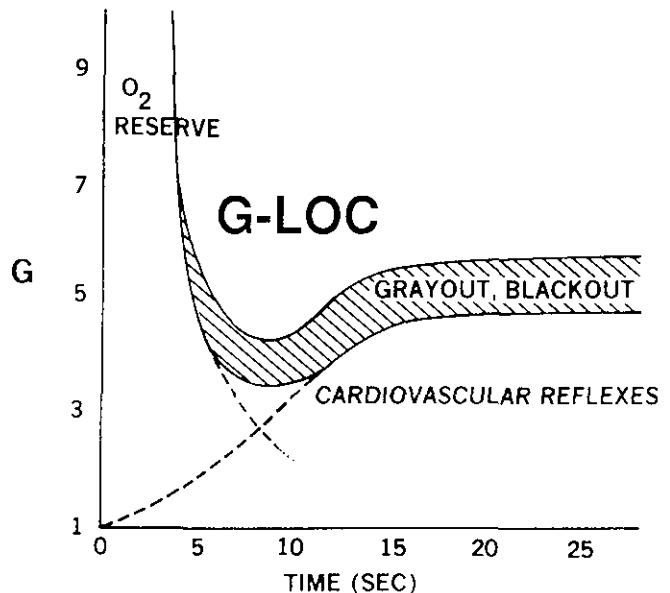

Figure 9. Human tolerance to +Gz and time.

**EFFECT OF G-ONSET RATE
 ON G TOLERANCE**

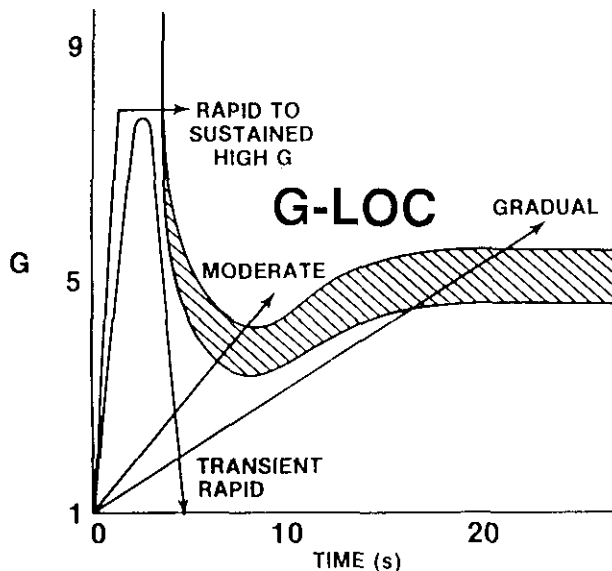

Figure 10. Human tolerance to +G_z and time at various +G_z onset rates.

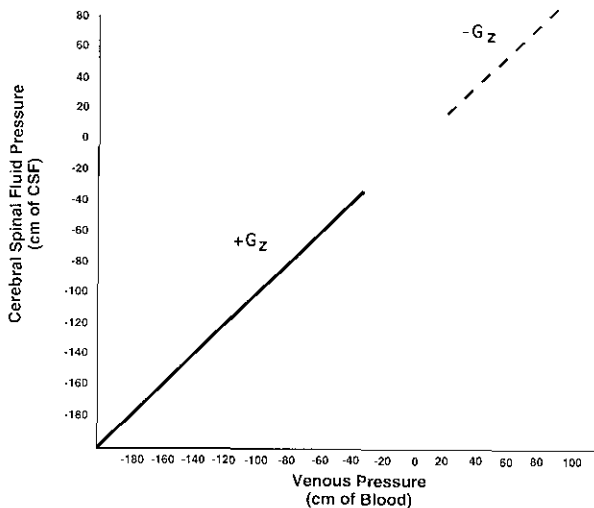

Figure 11. Linear relationship between intracranial venous blood pressure and cerebrospinal fluid pressure at the same vertical level, at both -G_z and +G_z. From Rushmer et al. *Am. J. Physiol.* 151:355-365, 1947.

can provide protection up to, or possibly greater than +9G_z, if used effectively. However, high +G_z is not a necessity for G-LOC; it can, and has occurred at relatively low +G_z levels (3-5 +G_z). G-LOC is unique to the flight maneuvering environment, including aerobatics and military aviation, in that it occurs in healthy aircrew. It is insidiously dangerous because it can happen with little or no warning. Figure 9 is a schematic of the G-time tolerance curve derived by Stoll (10) from human subject centrifuge data obtained by Beckman. Note there is a 5 sec energy (O₂) reserve where loss of consciousness does not occur, even at +9G_z. Cardiovascular reflexes, although triggered immediately upon +G_z, require approximately 10-15 sec for maximum effect; much too slow to provide any significant protection in the current high performance aircraft. The area below and to the left of the curve is consciousness and the area above and to the right of the curve is the area of unconsciousness. Figure 10 illustrates the effect of the rate of +G_z onset on the G-LOC response. When the onset of +G_z is gradual or moderate the visual symptoms of grayout and then blackout generally occur, providing a warning to the aircrew of impending G-LOC. However, if the onset rate is rapid (2G/sec or greater) and sustained beyond the energy reserve of the brain, then G-LOC can occur in an unprepared pilot without any warning. Note again that an aircrew can be exposed to very high +G_z for a period less than the O₂ reserve time without any visual symptoms.

It has always been assumed that G-LOC was the result of a dramatic reduction or cessation of cerebral blood flow during +G_z. Recently that assumption has been verified by the flow probe measurement of baboon cerebral blood flow during +G_z (13). LOC occurred 10-15 sec after cessation of cerebral blood flow during an exposure to +8G_z. Interestingly, the expected hyperemic response following G-LOC did not occur. Whereas, at the lower level of +4G_z a hyperemic response was observed.

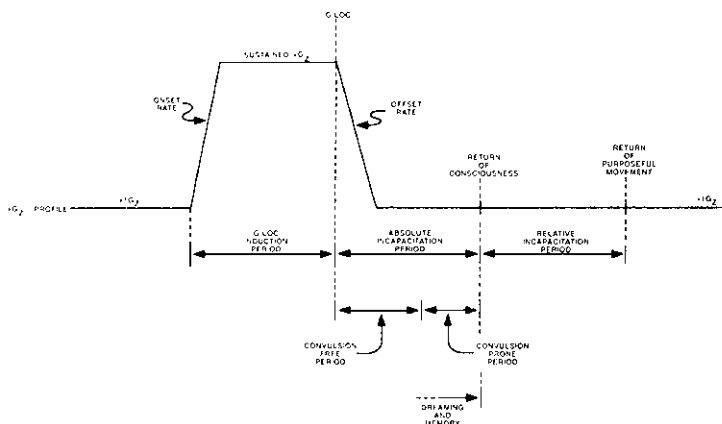

Figure 12. Schematic of the kinetics and secondary occurrences during G-LOC. From Whinnery, JE. *IEEE Eng. Med. Biol.* 10:41-45, 1991.

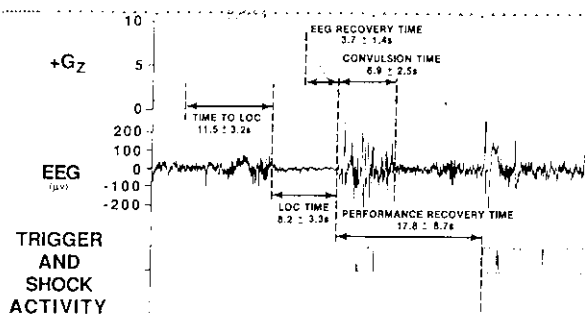

Figure 13. Kinetics, secondary occurrences and performance recovery during G-LOC in the unanesthetized baboon.

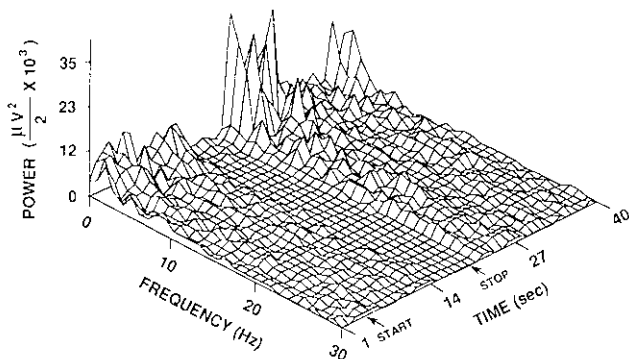

Figure 14. EEG power spectral analysis from unanesthetized baboon during G-LOC. Note isoelectric trough at time of G-LOC.

When rats are exposed to $+G_z$ and remain conscious the level of brain lactate, adenosine and other metabolites increase (12). However, when rats are exposed to higher $+G_z$ levels which result in G-LOC these metabolites are less than in conscious rats during $+G_z$. Thus, G-LOC may be a protective mechanism when perfusion is inadequate by limiting the excessive build-up of toxic metabolites.

Rushmer (9) demonstrated the positive correlation between intracranial venous pressure and cerebrospinal fluid pressure at the same vertical level in monkeys, during both $-G_z$ and $+G_z$ (Figure 11). These observations indicate that cerebral vasculature, especially the veins and small vessels, are almost perfectly protected from large and sudden changes in intravascular pressure during $+G_z$ by an equal change in cerebrospinal fluid pressure.

Figure 12 illustrates the kinetics and some of the secondary characteristics of G-LOC. Time to G-LOC during sustained $+G_z$ in the relaxed human is 5-7 sec (15). Similar data have been obtained by Rossen et al. using human subjects (8). They reported LOC within 6.8 sec after occlusion of cerebral blood flow using a rapid-filling inflatable cervical cuff. Time to LOC in the unanesthetized baboon during sustained $+8G_z$ was 11.5 ± 3.2 sec (Figure 13). The difference between man and the baboon is attributed to two major factors: 1) the baboon has a shorter eye-to-heart distance, thus providing added G-LOC protection; and 2) the unanesthetized baboon struggles during $+G_z$, which raises arterial blood pressure and thus increases $+G_z$ tolerance, requiring a longer time for G-LOC (1). Once G-LOC occurs, unconsciousness, or absolute incapacitation, lasts approximately 12-15 sec in man, sometimes associated with convulsions, followed by another 12-15 sec of relative incapacitation, where the pilot or centrifuge subject is confused or

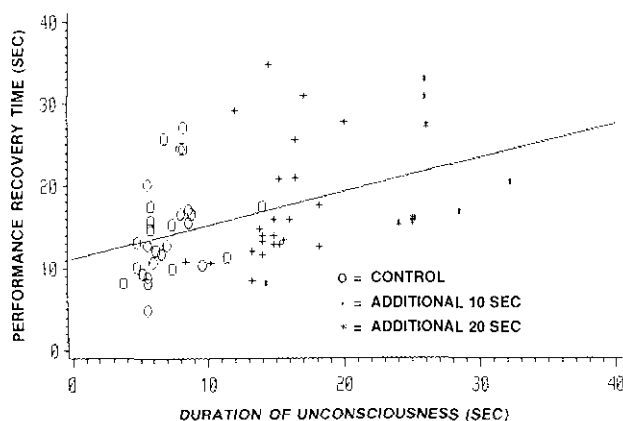

Figure 15. Performance recovery time following G-LOC versus duration of unconsciousness.

disoriented. In the baboon LOC is associated with an isoelectric EEG (Figures 13 and 14) which is followed by 6.9 ± 2.5 sec of convulsions as EEG activity returns after the $+G_z$ level is reduced, and then another 11 sec before performance has returned to control level. Performance recovery time in the baboon is extended when the duration of unconsciousness is prolonged (Figure 15).

Convulsions during G-LOC in the baboon lasted nearly twice as long as that reported in the human (14), possibly because of the extended time at LOC in the baboon. The tonic spasms, or hyperextension, and the convulsive activity observed in humans or animals during LOC are considered to be the result of loss of control by the cerebrum over the reticular formation (6). The electrical activity of the reticular activation system (RAS) has been shown to increase during LOC when cerebral activity has stopped (2). When the reticular formation has been experimentally destroyed, anoxic spasms or seizures do not occur (11). In the baboon tonic spasm, such as hyperextension of the head, occurred during the early phase of LOC, whereas convulsions did not occur until cerebral blood flow was reestablished during and after offset of $+G_z$ while the animal was still unconscious. The same observation has been reported in

humans after G-LOC (14), after neck occlusion (8) and after cardiac arrest (3).

Typical human observations during, and/or following some, but not all, G-LOC episodes:

- 1) unaware of LOC (amnesia)
- 2) no pre-LOC light loss or tunnel vision
- 3) convulsions or flail during LOC
- 4) tingling in the extremities and mouth
- 5) possible dreaming
- 6) confusion
- 7) euphoria
- 8) embarrassment
- 9) denial

References:

1. Burns, JW, PM Werchan, JW Fanton and AB Dollins. Performance recovery in the baboon following $+G_z$ -induced loss of consciousness. AL/CF-TR-1993-0110, Dec 1993.
2. Dell, PC. Humoral effects on the brain stem reticular formations. In: Reticular Formation of the Brain. Henry Ford Hospital International Symposium. London, Churchill. pp 365-379, 1957.
3. Gastaut, H and M Fischer-Williams. Electro-encephalographic study of syncope. Its differentiation from epilepsy. Lancet 2:2:1018-25, 1957.
4. McDaniel, JW. Strength capability for operating aircraft controls. In: Advances in Industrial Ergonomics and Safety. Ed. F Aghazadeh. Taylor & Francis, Bristol, PA. VI (pp 705-712), 1994.
5. Morgan, TR, RC Hill, JW Burns and RD Vanderbeek. Effects of G-layoff on subsequent tolerance to $+G_z$. Aviat. Space Environ. Med. 65:448, 1994.
6. Noell, WK and EB Dombrowski. Cerebral localization and classification of convulsions produced by severe oxygen

lack. SAM Proj. 497-1. School of Aviation Medicine, Randolph Field, TX, 1947.

7. Ripley, GL, KE Solona and RC Hill. Female anti-G suit fit and comfort. *SAFE J.* 24:41-45, 1994.

8. Rossen, R, H Kabat and JP Anderson. Acute arrest of cerebral circulation in man. *Arch. Neurol. & Psychiat.* 50:510-528, 1943.

9. Rushmer, RF, EL Beckman and D Lee. Protection of the cerebral circulation by the cerebrospinal fluid under the influence of radial acceleration. *Am. J. Physiol.* 151:355-365, 1947.

10. Stoll, AM. Human tolerance to positive G as determined by the physiological end points. *J. Aviat. Med.* 27:336-339, 1956.

11. Ward, Jr., AA. Decerebrate rigidity. *J. Neurophysiol.* 10:89-104, 1947.

12. Werchan, PM, R Echon, JA Barber, S Galindo, Jr. and AR Shahed. Estimation of rat cerebral blood flow during +G_z centrifuge exposure leading to G-induced loss of consciousness. *Society for Neurosci. Abstr.* 19:part 2, p 1220.

13. Werchan, PM, JC Schadt, JW Fanton and MH Laughlin. Total and regional cerebral blood flow during recovery from G-LOC. *Aviat. Space Environ. Med.* Submitted.

14. Whinnery, JE. Observations on the neurophysiologic theory of acceleration (+G_z) induced loss of consciousness. *Aviat. Space Environ. Med.* 60:589-593, 1989.

15. Whinnery, JE. Theoretical analysis of acceleration-induced central nervous system ischemia. *IEEE Eng. Med. Biol.* 10:41-45, 1991.

LES ETUDES MENEES PAR L'AGARD ET LES AVANCEES NOUVELLES POUR LES PROGRAMMES FUTURS

par

J.M. CLERE, P. SANDOR, A. LEGER*

Laboratoire de Médecine Aérospatiale
Centre d'Essais en Vol
F-91228 Brétigny-sur-Orge Cedex
FRANCE

* Sextant Avionique
rue Toussaint Catros, BP n° 91
F-33166 Saint-Médard en Jalles
FRANCE

1. INTRODUCTION

L'AGARD, de son nom anglais "Advisory Group for Aerospace Research and Development" est une agence du comité militaire de l'Atlantique Nord (OTAN). L'AGARD est un groupe d'experts appartenant à différents thèmes de recherche.

Ces groupes d'experts sont appelés Panel et sont au nombre de 7. Ils ont tous pour vocations de:

- recommander des moyens efficaces permettant aux pays membres d'utiliser leurs capacités de recherche et de développement pour le bénéfice de la communauté de l'OTAN,
- d'apporter des conseils et une aide scientifiques et techniques au comité militaire de l'OTAN dans le domaine de la recherche et des réalisations aérospatiales (en particulier les applications militaires),
- faire progresser les sciences aérospatiales susceptibles de renforcer la défense aérienne,
- Améliorer la coopération entre pays membres dans le domaine de la recherche et des réalisations aérospatiales,
- Echanger des informations scientifiques et techniques,
- Apporter une aide aux pays membres afin d'accroître leur potentiel scientifique et technique,
- Fournir une assistance scientifique et technique selon les besoins exprimés aux autres organismes de l'OTAN et aux pays membres.

Le Panel de Médecine Aérospatiale est un des 7 panels. Au même titre que les autres, il cherche à assurer l'ensemble des missions qui ont été évoquées auparavant en tenant compte des directives érigées par le conseil des délégués nationaux.

A ce jour, 3 directives sont en vigueur:

- dégager de l'opération "tempête du désert" l'expérience acquise pour assurer une amélioration des procédures d'emploi des forces et une amélioration des systèmes utilisés dans le cadre de ce type d'opération.

- étudier les facteurs rentrant en jeu lors d'opérations militaires en temps de paix pour mettre au point les études devant être menées par chacun des pays membres. Ces études doivent déboucher sur le développement de nouvelles recherches et sur l'évolution des technologies assurant la garantie de l'efficacité de ces opérations.

- prévoir, à travers le projet "AGARD 2020", les évolutions scientifiques et techniques majeures devant apparaître durant les 2 prochaines décennies pour pouvoir mieux assurer leurs développements.

Le Panel de Médecine Aérospatiale, composé de quatre sous comités (systèmes de protection des équipages, sciences cliniques, facteurs humains, systèmes neuro-sensoriels) ont pour

thèmes ceux de la médecine, de la physiologie et de la psychologie. Il s'agit d'améliorer l'efficacité et la protection des personnels impliqués dans les opérations militaires de l'OTAN à destinée aéronautique ou spatiale.

Depuis les dernières années, les symposia, les cours, les conférences à thèmes (appelées communément de leur nom anglais "Lecture Series"), les groupes de travail ont tenté d'atteindre au mieux ces buts.

Dans le cadre des accélérations +Gz, plusieurs thèmes font l'objet du travail de présentation ci-après.

2. ETUDES MENEES PAR L'AGARD DANS LE CADRE DES ACCELERATIONS +Gz

Depuis le début de l'aviation, chaque génération d'avion a eu une vitesse plus élevée que la génération précédente. A contrario, les avions de combat du type F14, F15, F16, F18, Mirage 2000, Tornado ne correspondent pas à ce critère puisque, la plupart d'entre eux, ont des vitesses égales ou inférieures à celles des avions précédents (F-4 Phantom, Mirage III, Lightning, etc...). Bien qu'à première vue, ils puissent ne pas être très différents, ces avions ont des caractéristiques spécifiques qui entraînent des contraintes physiques supérieures à celles rencontrées sur la génération d'avions précédente.

En effet, l'introduction massive de l'informatique embarquée et une nouvelle aérodynamique, complétée par un (ou/des) moteur(s) assurant un rapport poussée - poids supérieur à un - ont permis des évolutions plus serrées et plus contraignantes pour le pilote. Les accélérations sont devenues élevées (>7 +Gz), et peuvent être soutenues sans diminution de la vitesse de l'avion, elles sont appliquées de façon rapide (jusqu'à 10 G/s). Ce domaine de contrainte mécanique était inconnu de façon opérationnelle sur la génération d'avions précédente. C'est pourquoi plusieurs études ont été menées dans les pays de l'OTAN et parfois sous l'égide de l'AGARD pour s'assurer de la capacité des pilotes non seulement à tolérer ces

accélérations mais aussi pour s'assurer de leur intégrité physique malgré l'environnement.

Ces travaux, menés par plusieurs équipes de cliniciens ou de physiologistes, peuvent être regroupés de façon schématique en trois thèmes :

- pathologie cardio-vasculaire observée sur modèles animaux
- anomalies cardio-vasculaires observées sur l'homme et imputées aux accélérations +Gz
- manifestations ostéo-musculaires et vestibulaires liées à des accélérations +Gz élevées et soutenues.

2.1 Les manifestations cardio-vasculaires observées sur modèle animal

Toute une série de manifestations pathologiques a été observée sur les coeurs d'animaux centrifugés. En effet, Burton et MacKenzie (1975) et MacKenzie et coll. (1976) ont montré que des mini-porcs soumis à des accélérations élevées, soutenues et répétées durant plusieurs semaines développaient des cardiomyopathies et des hémorragies sous endocardiques. Ces observations ont alors provoqué une inquiétude dans la communauté scientifique mais des travaux complémentaires ont amendé ces craintes initiales.

En effet, un travail (Burns et Coll., 1983) a montré que ces manifestations pathologiques n'étaient pas directement liées aux accélérations mais aux effets de la contention. L'immobilisation de ces animaux par une contention stricte provoquait un stress par lui-même. La concentration en hydroxyproline, considérée comme un facteur favorisant ces manifestations pathologiques, était d'autant plus élevée que le stress de contention se prolongeait.

Un autre travail (Gillingham, 1978) est venu lui aussi tempérer les inquiétudes initiales. Un sujet d'expérimentation, qui avait plus de 700 lancements en centrifugeuse, dont un grand nombre était supérieur à 6 +Gz, se tua dans un accident automobile. Son autopsie révéla qu'il ne présentait aucune manifestation histologique au niveau des structures endothéliales et de son myocarde.

Néanmoins le doute persistait et l'inquiétude du corps médical amena, en France, l'utilisation de l'écho cardiographie comme moyen de sélection des pilotes de Mirage 2000 afin de s'assurer de l'intégrité cardio-vasculaire de ces pilotes.

2.2 Etude échocardiographique - Groupes de travail N° 13 et 18

"Etude échocardiographique des équipages de l'OTAN"

Afin de s'assurer de l'intégrité cardio-vasculaire des nouveaux pilotes de Mirage 2000, l'Armée de l'Air française a autorisé le Centre Principal d'expertise du personnel navigant à pratiquer une écho cardiographie chez des pilotes de Mirage III, F1 et Jaguar. Les premières observations ont alors montré qu'une grande partie de ces pilotes avaient un coeur de dimension supérieure à la moitié du thorax. Le coeur droit semblait hypertrophié. Une étude comparative mit alors en évidence une différence significative entre les dimensions du coeur droit des pilotes de combat et celles des coeurs de pilotes d'avion de transport (Ille et coll., 1985). Une étude en composante principale a cherché à définir quelles étaient les variables échocardiographiques les plus importantes (Quandieu et coll., 1986). Un autre travail ayant pour objet d'expliquer l'origine de ces anomalies montre que la pression dans le ventricule droit chez un babouin soumis à une accélération de 7 +Gz est triple de celle mesurée au repos (Borredon et coll., 1986).

C'est ainsi que les groupes de travail N° 13 et 18 sur l'écho cardiographie ont été successivement créés en 1987 et 1991. Le premier groupe a établi un protocole d'examen échocardiographiques reconnus par les différentes équipes de l'OTAN, puis a constitué, à partir des données observées en France, une base de données unique et a formulé l'analyse statistique adaptée (AGARD, 1990). Cette base de données est gérée par le service de cardiologie de la base de Brooks AFB. Le deuxième groupe de travail, actuellement en exercice, a pour mission d'effectuer une étude longitudinale des dimensions du coeur des pilotes d'avions de chasse au cours de leur carrière. A chaque

étape, le groupe informe la communauté scientifique s'il y a lieu de statuer sur l'éventuel aspect pathogène des accélérations +Gz.

Mais les accélérations élevées et soutenues, si elles sollicitent particulièrement le système cardio-vasculaire, sollicitent aussi d'autres organes en particulier le rachis vertébral et ses muscles ainsi que le système vestibulaire.

2.3 Le système vertébral et musculaire - groupe de travail N° 17

Des incidents ou des accidents pathologiques intéressant la sphère musculo-squelettique des pilotes soumis aux accélérations +Gz ont été rapportés depuis très longtemps (Phillips, 1959). Avec la mise en service des avions du type F16 et F18, les inquiétudes du corps médical ont été confirmées par plusieurs exemples. En effet, une figure aérienne à 8 +Gz sur F-16 a entraîné une fracture-compression de la sixième vertèbre cervicale chez un médecin du personnel navigant alors que celui-ci avait la tête en rotation gauche (Andersen, 1988).

Plusieurs études (Schall, 1983, 1989) ont montré des fractures compression des corps vertébraux des cinquième et sixième cervicales et des hernies des disques intervertébraux, en particulier du nucleus pulposus, des C5-6 et C6-7 chez des pilotes de F15 et F16. Certaines de ces hernies ou fractures étaient accompagnées d'un syndrome cervico-brachial avec paresthésies au niveau du bras gauche et ont nécessité soit, un traitement avec une minerve et des analgésiques soit, une chirurgie fixatrice. Une de ces études rapporte une triple fracture cervicale avec tétraparésie lors d'un vol en G négatif sur F4.

Des études systématiques menées à l'aide de questionnaires anonymes ont cherché à mettre en évidence une relation entre les manifestations pathologiques et le niveau d'accélération.

Il a été établi que les pilotes de F-18 ont plus de manifestations pathologiques que les pilotes de A-7 et de A-4 (ayant un niveau d'accélération moindre) et que la position "check 6" (rotation

arrière de la tête) favorise ces manifestations (Knudsen et coll., 1988).

D'autres études ont montré que 10% des pilotes suivant un entraînement en centrifugeuse à 8 +Gz présentaient des douleurs rachidiennes (Wurster et coll., 1990) et que plus de 60% des sujets participant à une expérimentation concernant la mobilité de la tête sous faible facteur de charge (<5 +Gz) présentaient des cervicalgies (Léger, 1989).

Dans les armées de l'air finlandaise (Aho et coll., 1990) et suédoise (Harms-Ringdahl et coll., 1991) respectivement 48 et 43% des équipages d'avion de combat paraissent souffrir de cervicalgies.

La prévalence de ces manifestations dans toutes les armées de l'air a abouti à l'organisation d'un symposium par le panel de médecine aérospatiale de l'AGARD en 1990. A la suite de ce symposium et pour édicter des règles visant à réduire ces manifestations, le groupe de travail N° 17 a été organisé.

Son travail, publié dans le volume AGARD AR 317, a eu pour objet de statuer sur le suivi médical et physiologique des pilotes et de présenter des recommandations concernant les équipements de tête et de proposer des mesures de prévention pour la sélection et l'entraînement.

Certains pays (France, Norvège, Belgique, etc...) de l'OTAN fondent leur sélection sur des radiographies du rachis mais les clichés ne sont pas automatiquement interprétés de la même façon par chaque équipe et il est nécessaire d'uniformiser les critères de pathologie et de sélection (Kazarian et Bek, 1979). De plus, le risque des rayons X semble excessif pour certaines équipes des pays de l'OTAN par rapport à l'intérêt qu'apporte la radiologie.

La sélection des équipages peut aussi s'appuyer sur des nouvelles techniques d'investigation comme l'imagerie à résonance magnétique nucléaire (IRM) qui ne présente pas ces risques. En revanche, cette nouvelle méthode est critiquable par la variabilité des interprétations

des clichés IRM. Ainsi, deux études ont montré que des clichés, interprétés de façon indépendante par deux spécialistes différents, n'aboutissaient à une interprétation similaire que dans 23%, voire 11% des cas! Bien qu'il soit nécessaire de sélectionner les équipages, il ne semble donc pas exister de techniques d'investigation faisant l'unanimité quant à leur valeur prédictive et à leur innocuité.

Par ailleurs, il a été démontré que les muscles du cou sont sollicités à plus de 100% lors d'accélération élevées lorsque la tête est en rotation. Un entraînement physique spécifique a donc été proposé afin d'augmenter la force de ces muscles.

A côté de ces moyens physiologiques (entraînement), plusieurs pays ont développé des moyens technologiques visant à réduire les contraintes. Ainsi, le casque peut être allégé grâce à l'utilisation de nouveaux matériaux; en revanche, l'équipement de tête est de nouveau alourdi par l'introduction du viseur visuel de casque, nouvel élément du système d'armes. Des systèmes d'aides à la mobilité de la tête ont été également développés. Il s'agit de divers dispositifs qui viennent supporter la tête en prenant appui soit sur les épaules de l'utilisateur, soit sur le siège. Ces systèmes ont été imaginés et dessinés voire réalisés et testés en laboratoire.

La répétition des accélérations élevées obtenues dans un avion d'entraînement performant, semble être une excellente méthode pour réduire le risque de traumatismes cervicaux. En effet, il a été montré que les pilotes qui n'avaient pas volé pendant une longue période présentaient un risque plus élevé de traumatismes du cou que ceux qui volaient régulièrement. C'est pourquoi, après un arrêt prolongé, il est recommandé de s'entraîner sur ce type d'avion avant de piloter un avion de combat.

2.4 Le système vestibulaire - groupe de travail N° 17

L'orientation dans l'espace fait appel à des capteurs (oeils, système vestibulaire, propriocepteurs) et aux structures supérieures

du système nerveux pour intégrer les informations provenant de ces capteurs.

Les otolithes étant sensibles, par leur structure, aux accélérations, il a été suggéré que des accélérations élevées et soutenues peuvent être à l'origine d'altérations fonctionnelles ou lésionnelles. En fait, l'expérience acquise dans ce domaine repose sur des données provenant d'expérimentations menées en centrifugeuse ou de cas cliniques faisant suite à des vols de combat ou de voltige aérienne:

Les observations en centrifugeuse sont extrêmement limitées et ont été rapportées dans trois situations différentes.

Au cours des très nombreuses expérimentations menées en centrifugeuse à des niveaux d'accélération inférieurs à 9 +Gz aucun trouble pathologique n'a été relaté. Le seul cas pathologique chez l'homme a été observé à très haut facteur de charge: à la suite d'un entraînement à un niveau d'accélération supérieur à 15 +Gz, dans la centrifugeuse de Johnsville dans le cadre du programme X-15, un sujet a présenté des anomalies de l'équilibre qui ont été attribuées à une séparation otoconiale. Chez l'animal, ce type d'incident a été observé pour des accélérations de plus de 12 +Gz soutenues au moins 3,25 minutes (Lychakov D.V., 1988).

L'aviation de combat ne semble pas non plus avoir fait l'objet de pathologies vestibulaires liées aux accélérations. En revanche, lors d'une présentation de voltige aérienne effectuée au cours du championnat de Belkeschaba, un vertige giratoire a été déclenché par une accélération d'environ 11 -Gz (Ivanova, 1984). Ce vertige régressa spontanément entre la deuxième et la huitième semaine. Un bilan paraclinique complet ne mit pas en évidence d'anomalies particulières; ce bilan comportait des potentiels évoqués somatographiques, un écho-cochléogramme, des oto-émissions acoustiques, un électroencéphalogramme et une psychométrie.

Il ne semble pas exister de raisons particulières pour évoquer un risque potentiel vestibulaire lorsqu'un pilote est soumis à une accélération

supérieure à 15 +Gz de courte durée (comme cela se produit lors des éjections). En revanche, il y a lieu d'être plus circonspect si cette accélération se prolonge, comme dans le cas de l'entraînement des pilotes de X-15 sur la centrifugeuse de Johnsville.

Pour s'assurer de l'intégrité fonctionnelle du labyrinthe, plusieurs tests paracliniques peuvent être utilisés. Ils sont décrits dans une batterie de tests devant être effectués dans l'ordre chronologique suivant:

- électroystagmographie
- test des saccades oculaires
- étude du nystagmus spontané et stimulé
- test de poursuite visuelle
- test de positionnement dans l'espace
- test calorique.

Ces tests n'ont qu'une valeur qualitative et ne peuvent être interprétés que par des spécialistes. C'est pourquoi la recherche de moyens adaptés et fiables a fait l'objet d'un rapport récent destiné à apprécier la valeur prédictive de ces tests (Von Gierke, 1992).

Il existe des alternatives à cette batterie de tests; En effet, l'utilisation de générateurs d'illusions sensorielles permet soit d'évaluer la composante vestibulaire lors de la désorientation spatiale, soit de sensibiliser les équipages à cette désorientation. Ces générateurs d'illusions sensorielles sont utilisés par certaines forces aériennes en complément de la centrifugeuse.

A ce jour, la détection d'une fragilité vestibulaire chez certains pilotes et l'entraînement aux illusions sensorielles restent une préoccupation qui ne recevra de réponse véritablement opérationnelle qu'après de nombreux travaux. Une base de données, répertoriant les profils de stimulation et l'évolution des variables vestibulaires, est en cours de constitution au sein du Panel de Médecine Aérospatiale de l'AGARD. Cette base de données devrait permettre à moyen terme de mettre au point la sélection et l'entraînement les plus efficaces.

Les problèmes d'altération pathologique du vestibule d'une part et/ou d'altération fonctionnelle d'autre part s'intègrent dans le

sous des facteurs de charges plus élevés dans la mesure où la phonation resterait encore possible.

3.4.3 Innocuité des accélérations

L'absence d'effet pathologique chez l'homme du nouvel environnement lié aux performances des avions doit être vérifiée grâce à des études sur modèle animal puis sur l'homme soumis à de très hauts facteurs de charge ($> 12 +Gz$).

Il a en fait été montré que l'utilisation de la surpression ventilatoire pouvait entraîner des douleurs au niveau des membres supérieurs lorsque ceux-ci sont en position basse (Prior et coll., 1993). Cependant, l'expérience acquise en France montre que ces douleurs disparaissent dans la mesure où ces membres sont en position élevée (Clère, 1994).

Il sera nécessaire d'établir des bases de données OTAN pour évaluer à long terme l'innocuité des accélérations rencontrées dans ces nouveaux avions.

Bibliographie

Aho J., Homalainen O., Vanharanta H. Neck pain among Finnish military pilots. *Ann. med. Milit. Fenn.*, 1990, 65: 74-90.

AGARD AR-297. Echocardiography in NATO Aircrew. 1990.

Andersen H.T. Neck injury during exposure to sustained high-G forces in the F-16B. *Aviat. Space Environ. Med.*, 1988, 59: 356-8.

Anton D., Burton R.R., Flageat J. Léger A., Oosterveld W. The musculoskeletal and vestibular effects of long term repeated exposure to sustained High G. AGARD-AR-317, 1994.

Barer B. Communication personnelle avec Mr. Clère - 1992.

Borredon P., Paillard F., Liscia P., Cailler B., Ille H., Didier A. Coeur droit et accélérations $+Gz$ soutenues et de haut niveau. *Rev. Méd. Aéro. et Spat.*, 1986, 25, (98): 139-44.

Burns J.W., Laughlin M.H., Witt W.M., Young J.T., Ellis J.P. Pathophysiologic effects of acceleration stress in the miniature swine. *Aviat. Space Environ. Med.*, 1983, 54: 881-93.

Burton R.R., McKenzie W.F. Cardiac pathology association with high sustained $+Gz$: I Subendocardial hemorrhage. *Aviat. Space Environ. Med.* 1976, 47: 711-7.

Clère J.M. Effets physiologiques de la ventilation en pression positive sous accélération $+Gz$. Thèse en Sciences, Paris XI, Orsay, 5 Jan. 1994.

Frazier J.W., Repperger D.W., Toth D.N., Skowronski V.D. Human tracking performance during combined $+Gz$ and $\pm Gy$ stress. *Aviat. Space Environ. Med.*, 1982, 53 (5): 435-9.

Gillingham K.K. Absence of high-G stress cardiopathy in a human centrifuge rider. USAF SAM-TR-78-17, 1978.

Harms-Ringdahl K., Ekholm J., Schüldt K., Linder J., Hogbeck T., Schyllert M.L. Neck and Lumbar pain, clinical examination, mobility, muscular strength and endurance in a group of jet pilots. *Aviat. Space Environ. Med.*, 1991, 62: 454 (abstract).

Ille H., Didier A., Allégrini N., Maurel C. Sélection et surveillance des pilotes de Mirage 2000: Apport de l'échocardiographie. AGARD, 1985, CP-396: 32.1-32.13.

Ivanova B. Communication personnelle avec Mr J. Firth, 1984.

Kazarian L.E., Belk W.F. Spinal column injuries and abnormalities. AMRL, 1979, TR-79-74.

Kerguelen M., Ossard G., Clère J.M. Influence de la surface de recouvrement des pantalons anti-G sur la tolérance aux accélérations $+Gz$ et la réponse cardio-vasculaire. CRE n° CEV/SE/LAMAS, 1995.

Knudson R., McMillan D., Doucette D., Seidel M. A comparative study of G induced neck injury in pilots of the F/A-18, A-7 and A-4. *Aviat. Space Environ. Med.*, 1988, 59: 758-60.

Léger A. Communication personnelle avec Mr J.M. Clère - 1989.

Lychakov D.V. et coll. Changes in the otolith apparatus of rats and fish after long-term rotation with increased acceleration. *Kosm. Biol. Aviat. Med.*, 1988, 22: 27-33.

McKenzie W.F., Burton R.R., Burns J.W. HSGz stress cardiomyopathy: pathogenesis and effect of physical conditioning. Preprints of the Annual Scientific Meeting. Aerospace Medical Association, Washington DC, 1976: 211.

McKenzie W.F., Burton R.R., Butcher W.I. Cardiac pathology associated with high sustained +Gz: II stress cardiomyopathy. *Aviat. Space Environ. Med.*, 1976, 47: 718-25.

Pillips P.B. Brain injury from high-G pull-out? *Aviat. Med.*, 1959, 30: 198 (abstract).

Prior et coll.

Quandieu P., Vicaut E., Lefèbvre J., Piédecocq, Ille H., Didier A. Etude de paramètres échocardiographiques obtenus chez deux populations de pilotes. I Analyse statistique. *Rev. Méd. Aéro. et Spat.*, 1986, 25, (99): 219-28.

Quandieu P., Vicaut E., Lefèbvre J., Boitard M., Piédecocq, Ille H., Didier A. Etude de paramètres échocardiographiques obtenus chez deux populations de pilotes. II Proposition d'un index échocardiographique généralisé. *Rev. Méd. Aéro. et Spat.*, 1986, 25, (100): 286-91.

Sandor P., Grateau P., Gulli Ch., Clère J.M. Influence du facteur de charge sur la reconnaissance vocale; aspects méthodologiques. RE n° CEV/SE/LAMAS, 1995.

Schall D.G. Non-ejection cervical spine fracture due to defensive aerial combat maneuvering in an RF-4C: a case report. *Aviat. Space Environ. Med.*, 1983, 54: 1111-6.

Schall D.G. Non-ejection cervical spine injuries due to +Gz in high performance aircraft. *Aviat. Space Environ. Med.*, 1989, 60: 445-56.

Von Gierke H.E. Evaluation of tests for vestibular function. *Aviat. Space Environ. Med.*, 1992, 63 (2 suppl): AI-A34.

Wurster W.H., Langhoff J., Burchard E.C. Neck injury prevention possibilites in a high-G environment experience with high sustained +Gz training of pilots in the GAF-IAM human centrifuge. AGARD-AMP, 1990, CP-471: 16.1-16.6.



REPORT DOCUMENTATION PAGE													
1. Recipient's Reference	2. Originator's Reference AGARD-LS-202	3. Further Reference ISBN 92-836-0016-9	4. Security Classification of Document UNCLASSIFIED/ UNLIMITED										
5. Originator	Advisory Group for Aerospace Research and Development North Atlantic Treaty Organization 7 rue Ancelle, 92200 Neuilly-sur-Seine, France												
6. Title	Current Concepts on G-Protection Research and Development												
7. Presented at/sponsored by	The AGARD AMP Lecture Series on "Current Concepts on G-Protection Research and Development" held in Ohio, USA, May 15-16, 1995; Königsbrück, Germany, June 12-13, 1995; and Farnborough, UK, June 15-16, 1995.												
8. Author(s)/Editor(s) Various			9. Date May 1995										
10. Author's/Editor's Address Various			11. Pages 132										
12. Distribution Statement	There are no restrictions on the distribution of this document. Information about the availability of this and other AGARD unclassified publications is given on the back cover.												
13. Keywords/Descriptors	<table style="width: 100%; border: none;"> <tr> <td style="width: 50%;">Aerospace medicine</td> <td style="width: 50%;">G-protection</td> </tr> <tr> <td>Flight crews</td> <td>Antigravity</td> </tr> <tr> <td>Flight clothing</td> <td>Stress (physiology)</td> </tr> <tr> <td>Pilots (personnel)</td> <td>Tolerances (physiology)</td> </tr> <tr> <td>G-suits</td> <td>Positive pressure</td> </tr> </table>			Aerospace medicine	G-protection	Flight crews	Antigravity	Flight clothing	Stress (physiology)	Pilots (personnel)	Tolerances (physiology)	G-suits	Positive pressure
Aerospace medicine	G-protection												
Flight crews	Antigravity												
Flight clothing	Stress (physiology)												
Pilots (personnel)	Tolerances (physiology)												
G-suits	Positive pressure												
14. Abstract	<p>A new class of fighter aircraft is emerging that will be operational or in advanced Test and Evaluation by 1995. These aircraft (e.g. MiG 31, YF-22, Eurofighter, Rafale) are capable of developing G far in excess of 9G (i.e. 12G will be a realistic capability). The operational envelope of these agile aircraft will depend upon the G protection provided to the aircrew. In response to this challenge, established and new laboratories using human-use centrifuges are developing new aircrew protection methods using different approaches yet frequently complementing the research of the others. These laboratories include: Armstrong Laboratory (US), SAM (UK), DCIEM (CA), LAMAS (FR), SAM (RU), KONIGSBRUCK Laboratory (GE) and FOA Laboratory (SW). In 1995, much of this research will have produced prototype flight-worthy equipment/methods with advanced understanding of their physiological bases. This lecture series will review: (a) pathophysiology of high sustained G (9G and above); (b) recent equipment development and reports on equipment T&E.</p>												



ASAP

NATO  OTAN

7 RUE ANCELLE • 92200 NEUILLY-SUR-SEINE
 FRANCE

Télécopie (1)47.38.57.99 • Télex 610 176

DIFFUSION DES PUBLICATIONS

AGARD NON CLASSIFIEES

Aucun stock de publications n'a existé à AGARD. A partir de 1993, AGARD détiendra un stock limité des publications associées aux cycles de conférences et cours spéciaux ainsi que les AGARDographies et les rapports des groupes de travail, organisés et publiés à partir de 1993 inclus. Les demandes de renseignements doivent être adressées à AGARD par lettre ou par fax à l'adresse indiquée ci-dessus. *Veuillez ne pas téléphoner.* La diffusion initiale de toutes les publications de l'AGARD est effectuée auprès des pays membres de l'OTAN par l'intermédiaire des centres de distribution nationaux indiqués ci-dessous. Des exemplaires supplémentaires peuvent parfois être obtenus auprès de ces centres (à l'exception des Etats-Unis). Si vous souhaitez recevoir toutes les publications de l'AGARD, ou simplement celles qui concernent certains Panels, vous pouvez demander à être inclu sur la liste d'envoi de l'un de ces centres. Les publications de l'AGARD sont en vente auprès des agences indiquées ci-dessous, sous forme de photocopie ou de microfiche.

CENTRES DE DIFFUSION NATIONAUX

ALLEMAGNE

Fachinformationszentrum,
 Karlsruhe
 D-76344 Eggenstein-Leopoldshafen 2

BELGIQUE

Coordonnateur AGARD-VSL
 Etat-major de la Force aérienne
 Quartier Reine Elisabeth
 Rue d'Evere, 1140 Bruxelles

CANADA

Directeur, Services d'information scientifique
 Ministère de la Défense nationale
 Ottawa, Ontario K1A 0K2

DANEMARK

Danish Defence Research Establishment
 Ryvangs Allé 1
 P.O. Box 2715
 DK-2100 Copenhagen Ø

ESPAGNE

INTA (AGARD Publications)
 Pintor Rosales 34
 28008 Madrid

ETATS-UNIS

NASA Headquarters
 Code JOB-1
 Washington, D.C. 20546

FRANCE

O.N.E.R.A. (Direction)
 29, Avenue de la Division Leclerc
 92322 Châtillon Cedex

GRECE

Hellenic Air Force
 Air War College
 Scientific and Technical Library
 Dekelia Air Force Base
 Dekelia, Athens TGA 1010

ISLANDE

Director of Aviation
 c/o Flugrad
 Reykjavik

ITALIE

Aeronautica Militare
 Ufficio del Delegato Nazionale all'AGARD
 Aeroporto Pratica di Mare
 00040 Pomezia (Roma)

LUXEMBOURG

Voir Belgique

NORVEGE

Norwegian Defence Research Establishment
 Attn: Biblioteket
 P.O. Box 25
 N-2007 Kjeller

PAYS-BAS

Netherlands Delegation to AGARD
 National Aerospace Laboratory NLR
 P.O. Box 90502
 1006 BM Amsterdam

PORTUGAL

Força Aérea Portuguesa
 Centro de Documentação e Informação
 Alfragide
 2700 Amadora

ROYAUME-UNI

Defence Research Information Centre
 Kentigern House
 65 Brown Street
 Glasgow G2 8EX

TURQUIE

Millî Savunma Başkanlığı (MSB)
 ARGE Dairesi Başkanlığı (MSB)
 06650 Bakanlıklar-Ankara

Le centre de distribution national des Etats-Unis ne détient PAS de stocks des publications de l'AGARD.

D'éventuelles demandes de photocopies doivent être formulées directement auprès du NASA Center for AeroSpace Information (CASI) à l'adresse ci-dessous. Toute notification de changement d'adresse doit être fait également auprès de CASI.

AGENCES DE VENTE

NASA Center for
 AeroSpace Information (CASI)
 800 Elkridge Landing Road
 Linthicum Heights, MD 21090-2934
 Etats-Unis

ESA/Information Retrieval Service
 European Space Agency
 10, rue Mario Nikis
 75015 Paris
 France

The British Library
 Document Supply Division
 Boston Spa, Wetherby
 West Yorkshire LS23 7BQ
 Royaume-Uni

Les demandes de microfiches ou de photocopies de documents AGARD (y compris les demandes faites auprès du CASI) doivent comporter la dénomination AGARD, ainsi que le numéro de série d'AGARD (par exemple AGARD-AG-315). Des informations analogues, telles que le titre et la date de publication sont souhaitables. Veuillez noter qu'il y a lieu de spécifier AGARD-R-*nnn* et AGARD-AR-*nnn* lors de la commande des rapports AGARD et des rapports consultatifs AGARD respectivement. Des références bibliographiques complètes ainsi que des résumés des publications AGARD figurent dans les journaux suivants:

Scientific and Technical Aerospace Reports (STAR)
 publié par la NASA Scientific and Technical
 Information Division
 NASA Headquarters (JTT)
 Washington D.C. 20546
 Etats-Unis

Government Reports Announcements and Index (GRA&I)
 publié par le National Technical Information Service
 Springfield
 Virginia 22161
 Etats-Unis
 (accessible également en mode interactif dans la base de
 données bibliographiques en ligne du NTIS, et sur CD-ROM)



AGARD

UNLIMITED

NATO  OTAN

7 RUE ANCELLE • 92200 NEUILLY-SUR-SEINE

FRANCE

Telefax (1)47.38.57.99 • Telex 610 176

DISTRIBUTION OF UNCLASSIFIED

AGARD PUBLICATIONS

AGARD holds limited quantities of the publications that accompanied Lecture Series and Special Courses held in 1993 or later, and of AGARDographs and Working Group reports published from 1993 onward. For details, write or send a telefax to the address given above. *Please do not telephone.*

AGARD does not hold stocks of publications that accompanied earlier Lecture Series or Courses or of any other publications. Initial distribution of all AGARD publications is made to NATO nations through the National Distribution Centres listed below. Further copies are sometimes available from these centres (except in the United States). If you have a need to receive all AGARD publications, or just those relating to one or more specific AGARD Panels, they may be willing to include you (or your organisation) on their distribution list. AGARD publications may be purchased from the Sales Agencies listed below, in photocopy or microfiche form.

NATIONAL DISTRIBUTION CENTRES

BELGIUM

Coordonnateur AGARD — VSL
Etat-major de la Force aérienne
Quartier Reine Elisabeth
Rue d'Evere, 1140 Bruxelles

CANADA

Director Scientific Information Services
Dept of National Defence
Ottawa, Ontario K1A 0K2

DENMARK

Danish Defence Research Establishment
Ryvangs Allé 1
P.O. Box 2715
DK-2100 Copenhagen Ø

FRANCE

O.N.E.R.A. (Direction)
29 Avenue de la Division Leclerc
92322 Châtillon Cedex

GERMANY

Fachinformationszentrum
Karlsruhe
D-76344 Eggenstein-Leopoldshafen 2

GREECE

Hellenic Air Force
Air War College
Scientific and Technical Library
Dekelia Air Force Base
Dekelia, Athens TGA 1010

ICELAND

Director of Aviation
c/o Flugrad
Reykjavik

ITALY

Aeronautica Militare
Ufficio del Delegato Nazionale all'AGARD
Aeroporto Pratica di Mare
00040 Pomezia (Roma)

LUXEMBOURG

See Belgium

NETHERLANDS

Netherlands Delegation to AGARD
National Aerospace Laboratory, NLR
P.O. Box 90502
1006 BM Amsterdam

NORWAY

Norwegian Defence Research Establishment
Attn: Biblioteket
P.O. Box 25
N-2007 Kjeller

PORTUGAL

Força Aérea Portuguesa
Centro de Documentação e Informação
Alfragide
2700 Amadora

SPAIN

INTA (AGARD Publications)
Pintor Rosales 34
28008 Madrid

TURKEY

Millî Savunma Başkanlığı (MSB)
ARGE Dairesi Başkanlığı (MSB)
06650 Bakanlıklar-Ankara

UNITED KINGDOM

Defence Research Information Centre
Kentigern House
65 Brown Street
Glasgow G2 8EX

UNITED STATES

NASA Headquarters
Code JOB-1
Washington, D.C. 20546

The United States National Distribution Centre does NOT hold stocks of AGARD publications.

Applications for copies should be made direct to the NASA Center for AeroSpace Information (CASI) at the address below. Change of address requests should also go to CASI.

SALES AGENCIES

NASA Center for
AeroSpace Information (CASI)
800 Elkridge Landing Road
Linthicum Heights, MD 21090-2934
United States

ESA/Information Retrieval Service
European Space Agency
10, rue Mario Nikis
75015 Paris
France

The British Library
Document Supply Centre
Boston Spa, Wetherby
West Yorkshire LS23 7BQ
United Kingdom

Requests for microfiches or photocopies of AGARD documents (including requests to CASI) should include the word 'AGARD' and the AGARD serial number (for example AGARD-AG-315). Collateral information such as title and publication date is desirable. Note that AGARD Reports and Advisory Reports should be specified as AGARD-R-*nnn* and AGARD-AR-*nnn*, respectively. Full bibliographical references and abstracts of AGARD publications should be included.



*332690**P*UL*

Printed by Canada Communication Group
45 Sacré-Coeur da KIA 0S7