

331761

128AP

AGARD-AR-335

AGARD-AR-335

AGARD

ADVISORY GROUP FOR AEROSPACE RESEARCH & DEVELOPMENT
7 RUE ANCELLE, 92200 NEUILLY-SUR-SEINE, FRANCE

L. Pollock 16/5/95

NOT FOR DESTRUCTION
PROCESSED BY DIMS

AGARD ADVISORY REPORT NO 335

Flight Vehicle Integration Panel Workshop on Pilot Induced Oscillations (Atelier sur le pompage piloté)

*This Advisory Report has been prepared at the request of the
Flight Vehicle Integration Panel of AGARD, formerly
the Flight Mechanics Panel.*

Processed / not processed by DIMS

.....CM.....signed.....Aug. 95.....date

NOT FOR DESTRUCTION

NORTH ATLANTIC TREATY ORGANIZATION



Published February 1995

Distribution and Availability on Back Cover

UNLIMITED

Preface

Instability of the pilot/airframe combination has probably been a problem from the beginning of manned flight. The rapid advances made in aviation following the Second World War greatly increased the incidence of PIO problems and led to a large amount of research and development work aimed at understanding and mitigating these difficulties. Criteria and requirements were developed which could be used in design to obtain satisfactory PIO qualities.

Nevertheless, in spite of all this work, and even with the great flexibility in modern control technologies available to the designer, PIO problems still often occur with new aircraft; in fact it is the power and responsiveness of modern control systems which makes them susceptible to various "non-linear" effects such as time delays, rate limits, actuator saturation, etc., leading to unexpected PIO difficulties.

It is thought that an AGARD Flight Mechanics Panel initiative on this topic would be timely and relevant.

A Workshop, involving presentations from appropriate specialists in the Handling Qualities, Control System Design and Testing fields, was proposed with the objectives of:

- Reviewing the experience of the problem.
- Re-examining the latest PIO research.
- Defining factors which may contribute to the development of PIO problems in an aircraft.
- Illuminating new methods which are being used to analyse and avoid/overcome these problems.

In order to get timely and full co-operation of specialists, the format of the workshop was informal briefings, material subsequently being selected and compiled to form this summary document.

This Workshop was integrated with the symposium on Active Control Technology, using the proposed round table discussion at the close of the symposium as the lead into the Workshop. The Workshop, itself, took place on the Friday following the symposium. It was chaired by an ex-Panel member with knowledge of the field who would be expected to produce a summary document for inclusion in the conference proceedings.

With current experience, it is clear that a universal solution of the PIO problem is still evading the engineering community. The cost of these problems in terms of programme delay and financial terms is significant, particularly when aircraft and crew safety may be or has been at risk.

The gathering together of specialists to discuss this problem from their various points of view was expected to lead to positive gains in the state of knowledge regarding PIOs, provide a significant step toward their elimination and contribute to the avoidance of PIO-associated programme costs and penalties.

In this regard, it is believed from the feedback, both at the time and subsequent to the Workshop, that the objectives were achieved or even exceeded. The open discussion of the problems and possible solutions has helped to foster a continuing openness which can only benefit all who are involved in the design, manufacture and procurement of aircraft which feature the type of control systems to which these problems most frequently apply.

Thanks are due to all those who made contributions to this Workshop and to those who facilitated its running in conjunction with the ACT Symposium.

Keith McKay
British Aerospace, Military Aircraft Division
Chairman, AGARD FMP PIO Workshop.

Préface

Il est vraisemblable que l'instabilité du couple pilote/cellule a posé des problèmes dès les premiers vols pilotés. Les progrès rapides réalisés dans le domaine de l'aviation après la deuxième guerre mondiale ont eu pour résultat, entre autres, la forte croissance des problèmes de pompage piloté (PIO), ainsi que le lancement d'un volume considérable de travaux de recherche et développements ayant pour but la compréhension et la mitigation de ces difficultés. Des critères et des spécifications de conception étaient élaborés pour assurer l'obtention de qualités PIO acceptables.

Cependant, en dépit de tout ce travail, et malgré la grande souplesse autorisée par les technologies de pilotage modernes, les concepteurs des nouveaux aéronefs rencontrent souvent des problèmes PIO. À vrai dire, la puissance et la sensibilité de fonctionnement mêmes des systèmes de pilotage modernes sont à l'origine de leur susceptibilité à divers effets «non-linéaires», tels que les retards, les limites de vitesse verticale, la saturation des vérins etc..., ce qui crée des difficultés PIO imprévues.

Le Panel AGARD de la Mécanique du Vol a considéré qu'il était opportun et approprié de prendre une initiative à ce sujet.

Un certain nombre de spécialistes dans les domaines des caractéristiques de manœuvrabilité, de la conception des systèmes de commande et des essais ont été invités à animer un atelier de travail avec pour objet de :

- faire le point de l'expérience acquise dans ce domaine
- réexaminer les résultats des derniers travaux de recherche en PIO
- définir les facteurs susceptibles de contribuer au développement des problèmes PIO
- d'exposer les nouvelles méthodes qui sont utilisées pour analyser et éviter/surmonter ces problèmes.

Afin d'assurer l'entière coopération des spécialistes au moment voulu, l'atelier a été organisé sous la forme d'une série de briefings en petit groupe, les textes ayant été sélectionnés et assemblés par la suite pour constituer le présent sommaire.

Cet atelier faisait partie du symposium sur les technologies des systèmes de contrôle actif, la table ronde qui clôturait le symposium ayant servi d'introduction aux travaux de l'atelier qui se sont poursuivis le vendredi. L'atelier a été présidé par un ancien membre du Panel avec une certaine expérience dans ce domaine, qui a été chargé d'établir un résumé des travaux pour le compte rendu du symposium.

Dans l'état actuel des connaissances, il semblerait que la solution universelle des problèmes de PIO échappe encore à la communauté technologique. Les coûts engendrés par ces problèmes suite aux retards accumulés sont considérables surtout lorsque la sécurité des équipages et des aéronefs est en cause.

Ce groupe de spécialistes, réuni pour discuter des différents aspects du problème, a eu pour mandat de faire avancer l'état des connaissances des phénomènes de PIO, de marquer une étape importante dans l'élimination des problèmes et de contribuer à la réduction des coûts et des pénalités qui grèvent les programmes de développement à l'heure actuelle.

Eu égard aux commentaires exprimés lors de l'atelier et par la suite, ces objectifs ont été atteints, voire même dépassés. La discussion ouverte sur les problèmes et les solutions possibles a favorisé une nouvelle ouverture d'esprit, qui ne peut être que bénéfique pour tous ceux qui sont impliqués dans la conception, la fabrication et l'acquisition des aéronefs qui intègrent les différents types de systèmes de commande concernés par ces problèmes.

Nos remerciements sont dûs à tous ceux qui ont présenté des communications lors de cet atelier, ainsi qu'à ceux qui ont facilité son organisation conjointement avec le symposium ACT.

Keith McKay
British Aerospace
Military Aircraft Division
Président, AGARD FMP Atelier de travail
sur le pompage piloté (PIO)

AGARD

ADVISORY GROUP FOR AEROSPACE RESEARCH & DEVELOPMENT
7 RUE ANCELLE, 92200 NEUILLY-SUR-SEINE, FRANCE

AGARD ADVISORY REPORT NO 335

Flight Vehicle Integration Panel Workshop on Pilot Induced Oscillations (Atelier sur le pompage piloté)

This Advisory Report has been prepared at the request of the Flight Vehicle Integration Panel of AGARD, formerly the Flight Mechanics Panel.

DRIC DISTRIBUTIONS
KENTIGERN HOUSE
65 BROWN STREET
GLASGOW G2 8EX
TELE: 041 224 2434



North Atlantic Treaty Organization
Organisation du Traité de l'Atlantique Nord

The Mission of AGARD

According to its Charter, the mission of AGARD is to bring together the leading personalities of the NATO nations in the fields of science and technology relating to aerospace for the following purposes:

- Recommending effective ways for the member nations to use their research and development capabilities for the common benefit of the NATO community;
- Providing scientific and technical advice and assistance to the Military Committee in the field of aerospace research and development (with particular regard to its military application);
- Continuously stimulating advances in the aerospace sciences relevant to strengthening the common defence posture;
- Improving the co-operation among member nations in aerospace research and development;
- Exchange of scientific and technical information;
- Providing assistance to member nations for the purpose of increasing their scientific and technical potential;
- Rendering scientific and technical assistance, as requested, to other NATO bodies and to member nations in connection with research and development problems in the aerospace field.

The highest authority within AGARD is the National Delegates Board consisting of officially appointed senior representatives from each member nation. The mission of AGARD is carried out through the Panels which are composed of experts appointed by the National Delegates, the Consultant and Exchange Programme and the Aerospace Applications Studies Programme. The results of AGARD work are reported to the member nations and the NATO Authorities through the AGARD series of publications of which this is one.

Participation in AGARD activities is by invitation only and is normally limited to citizens of the NATO nations.

The content of this publication has been reproduced directly from material supplied by AGARD or the authors.

Published February 1995

Copyright © AGARD 1995
All Rights Reserved

ISBN 92-836-1013-X



Printed by Canada Communication Group
45 Sacré-Cœur Blvd., Hull (Québec), Canada K1A 0S7

Table of Contents

	Reference
Preface	iii
Préface	iv
Editorial Summary by K. McKay	E-1
PIO — A Historical Perspective by D.T. McRuer and R.E. Smith	1-1
The Process for Addressing the Challenges of Aircraft Pilot Coupling by R. A'Harrah	2-1
Observations on PIO by R.H. Smith	3-1
Unified Criteria for ACT Aircraft Longitudinal Dynamics by R. Hoh	4-1
Looking for the simple PIO Model by J.C. Gibson	5-1
The Relation of Handling Qualities Ratings to Aircraft Safety by J. Hodgkinson	6-1
Experience of the R. Smith Criterion on the F-15 SMTD Demonstrator by D.J. Moorhouse	7-1
SCARLET: DLR Rate Saturation Flight Experiment by J.R. Martin and J.J. Buchholz	8-1
SAAB Experience with PIO by P.-O. Elgcróna and E. Kullberg	9-1
Aeroelastic Pilot-In-The-Loop Oscillations by W.J. Norton	10-1
Handling Qualities Analysis on Rate Limiting Elements in Flight Control Systems by D. Hanke	11-1
Calspan Experience of PIO and the Effects of Rate Limiting by C. Chalk	12-1



Editorial Summary

by

Mr. Keith McKay, FRAeS
Chairman,
AGARD FMP PIO Workshop
Manager, Airframe Technology EF2000
British Aerospace Defence
Military Aircraft Division
Warton Aerodrome
Preston, Lancs. PR4 1AX
United Kingdom

1) Introduction

Instability of the pilot/airframe combination has been a problem from the beginning of manned flight. The rapid advances made in aviation following the Second World War greatly increased the incidence of PIO problems and led to a large amount of research and development work aimed at understanding and mitigating these difficulties. Criteria and requirements were developed which could be used in design to obtain satisfactory PIO qualities. Nevertheless, in spite of all this work, and even with the great flexibility in modern control technologies available to the designer, PIO problems still often occur with new aircraft; in fact it is the power and responsiveness of modern control systems which makes them susceptible to various "non-linear" effects such as time delays, rate limits, actuator saturation, etc., leading to unexpected PIO difficulties. With current experience, it is clear that a universal solution of the PIO problem still evades the engineering community. The cost of these problems in programme delay and financial terms is significant. The gathering together of specialists to discuss this problem, from their various points of view, has led to positive gains in the state of knowledge regarding PIOs; it has provided a significant step toward their elimination and contributed to the avoidance of PIO associated programme costs and penalties.

A number of experts in the fields of Flying Qualities, Flight Testing, and Pilot Modelling were invited to attend the workshop and give their views and experience before an audience made up of those pilots and ACT engineering specialists, with an interest in the PIO problem, who cared to stay on in Turin for the extra day.

All of the contributors created an open and frank discussion of the problems which exist and with which the flight controls and flying qualities communities are still struggling to overcome. There were a number of significant inputs from the floor, either in response to questions or as comments regarding the individuals experience.

2) Report Structure

This editorial summary has been generated from the information provided, including the free discussions after each

presentation. The summary also acts as an overall introduction to the presentations.

For ease of both reading and editorial convenience, this report has been assembled with each of the presentations as separate sections, so that they can be treated as separate, stand alone papers, as well as being seen as a contribution to the overall workshop

Two papers have also been generated from the Workshop, the first being presented to the AIAA Guidance, Navigation and Control Conference, held in Phoenix, Arizona¹, and the second being included in the Conference Proceedings of the AGARD FMP ACT Symposium².

3) The Workshop Format

By agreement with the presenters, the Workshop was structured into a number of presentations, with a time allowance for questions following each. Initially, the objective was to complete the presentations in time to allow a general discussion, but this turned out to be impractical. Adequate levels of discussion were completed after each presentation.

The presentation titles and presenters, in order of presentation, were:

1. "PIO - A Historical Overview", -
D.T.McRuer, R.E.Smith
2. "The Process for Addressing the Challenges of Aircraft-Pilot Coupling"
R.A.Harrah
3. "Observations on PIO"
R.H.Smith
4. "Unified Criteria for ACT Aircraft Longitudinal Dynamics"
R.Hoh
5. "Looking for the Simple PIO Model"
J.C.Gibson
6. "Experience of the R.Smith Criterion on the F-15 STOL & Maneuver Technology Demonstrator"
D.J.Moorhouse

7. "Relation of Handling Qualities to Aircraft Safety"
J.Hodgkinson
8. "Scarlet: DLR Rate Saturation Experiment"
J.R.Martin & J.J.Buchholz
9. "SAAB Experience of Rate Limiting and PIO"
P-O.Elgcrona & E.Kullberg
10. "Handling Qualities Analysis of Rate Limiting Elements in Flight Control Systems"
D.Hanke
11. "An Investigation of Pilot Induced Oscillation Phenomena in Digital Flight Control Systems"
W.A.Flynn & R.E.Lee
12. "Calspan Experience of PIO and the Effects of Rate Limiting"
C.Chalk

4) The Workshop Presentations and Discussions

4.1) Historical Overview

Duane McRuer set the scene for the Workshop by providing a valuable background history to the subject of PIO. In this he was ably supported by Rogers Smith. The records, on both video and as time histories, of the PIOs which have occurred provided very graphic and sobering evidence of the problems and consequences with which pilots can be confronted.

These problems have manifested themselves since the earliest days of manned flight. The earliest recorded examples of Pilot Induced Oscillation date back to the Wright Brothers first aircraft. The earliest video record dates from just before World War II, with the XB-19 aircraft which suffered a pitch PIO on touchdown.

The examples on video covered aircraft from the XB-19, through to aircraft such as the Space Shuttle, the YF-22 and, most recently, the JAS-39 Grippen. The video included the F-4 incident, when the aircraft was destroyed as the PIO diverged. It was noted that often in the past the blame had been apportioned to the pilot, who might be referred to as "ham handed", and in one case, the XF-89, the problem was solved by a change of pilot.

The influence of variable pilot gain in the problem is significant, and easily shown by the various types of task for which PIO is notorious, e.g. precision landing in turbulent conditions, air to air tracking, flight refuelling, etc. Most of the videos related to landing, although in the case of the YF-22, the aircraft was performing a low fly by for publicity purposes and the second JAS-39 incident occurred during an airshow.

Certainly one of the major problems that was highlighted in this session related to the recognition and reporting of PIO incidents. There is a tendency for pilots not to recognise the event which has occurred as a PIO or to admit or discuss the event, having struggled with the problem and survived. In at least the case of the YF-22, the pilot was unaware that he was

in a PIO, although he was aware of a control problem. This is a usual and typical reaction, and is characterised by the pilot feeling totally disconnected from the response of the aircraft. There is an apparent strong feeling that to admit to a PIO is to invite blame, which is incorrectly apportioned to the pilot and this aspect was addressed later and in more detail during the Workshop.

The presenters have concluded that the occurrence of PIO must be regarded as a failure of the design process. In some cases, such as the YF-16 or the JAS-39, the potential for a problem was identified before flight trials commenced, by various means. However, for one reason or another, the message was not reacted to in time and the consequence was the occurrence of an incident or accident.

It was noted that all the catastrophic PIO occurrences included the adverse effects of actuator rate limiting. This was to be dealt with in some detail in later presentations to the meeting, as were the possible strategies for alleviating the problems which arise from the excessive phase delays which actuator rate limiting bring about.

A good initial reference for the understanding of the PIO and its subsequent development is provided by reference 2, published recently by AGARD. This report, which deals with the handling qualities of highly augmented aircraft, and the Working Group that produced it, have provided much needed discussion of the problem and allowed a sharing of the understanding from all interested parties within NATO.

In the discussions which followed this presentation, there were a number of comments regarding the adequacy of the design process and the need to adequately "stress" the control system design before flight. In particular, one comment related to the Lavi where a moving base simulation suggested problems, but that this was eliminated prior to flight and no PIOs have ever occurred. The problems seen related to actuator rate limiting in one case, associated with crosswind landing, where it was possible for the pilot to become out of phase with the aircraft response.

The more unusual example quoted from this aircraft related to the effects of asymmetric stores under manoeuvre loads. Under these conditions, the pilot would move the stick to recover the lateral balance, but the FCS demanded roll rate in response to the stick motion. The results gave clear evidence of a tendency to PIO prior to flight. The effects was fixed.

It was commented that the Space Shuttle fails all criteria that it can be subjected to, and requires very experienced pilots and careful handling. The view was expressed that the vehicle only awaits the "trigger" for a major happening!

4.2) The Process for Addressing the Challenges of Aircraft-Pilot Coupling

The objective of the design, as described by Ralph A'Harrah, should be the provision of an aircraft and control system

which has Level 1 handling qualities and is free from PIO, or as Ralph preferred, **Aircraft-Pilot Coupling**.

This proposed name takes the emphasis away from the contribution of the pilot, although it is recognised that the problem cannot occur in the absence of the pilot. The essence is that Aircraft-Pilot Coupling is a design failure in the flight control system, to which the pilot will unwittingly contribute by performing his task, i.e. that of controlling the aircraft to meet his particular performance requirements.

It was suggested that a good starting point for the design process would be the design requirements set out in Mil-F-8785C, supplemented by the guidelines of Mil-STD-1797, or any other criteria with which the design organisation in question has experience and which can be demonstrated to have merit.

Ralph A'Harrah recommended that the Total Quality message was appropriate for this application, i.e. right first time, and that to achieve this required the building of a design team which sees the design through from concept to implementation and test. The team should consist of control system designers, handling quality experts, pilots, simulation engineers and, most significantly, must include managers for it to be successful and ensure that all buy into the problems and their solutions.

In following the process to the achievement of an aircraft which is free of adverse A-PC characteristics, it was noted that the key is to ensure that the design in question is adequately "stressed", i.e. that the FCS is rigorously examined for the possibility of aircraft-pilot coupling using the best tools and facilities that are available to the team. In the event that the results obtained are suspect, then the analysis must be taken to the point of developing a fix, prior to flight test, if possible.

In the discussion which followed the presentation, the example of the X-31 aircraft was quoted by Rogers Smith as being one where the programme moved forward very smoothly once the team was co-located at Dryden. The international team was described as "seamless", once all the specialists were gathered together. Prior to this point, there had been some working difficulties when the FCS design team were remote to the test and development activity.

4.3) Design Criteria for PIO Assessment

A common theme which emerged from a number of the presentations is that, as yet, there is no common, unified view with regard to the design criteria which should be used to design and evaluate systems to be free of PIO tendencies. This aspect was particularly illustrated by the presentations which followed in this next section.

The views expressed are those of the presenters and, clearly, some represent extreme views not held by the majority of people working in the field.

Design criteria based upon service experience are not available as, it is suspected, most occurrences are not reported or perhaps even recognised. Within experience in Europe, however, those occurrences which are known about, at least to the author, do not show any marked difference in character from those which have occurred in flight test, although the range of configurations may be extended.

There were considerable arguments as to which criterion was best, but perhaps the message should really be that there is no one criterion, proven as yet, which fully describes all of the problems which may be encountered and can be applied without significant "limitation as to applicability" and engineering interpretation.

4.3.1) Observations on PIO

The meeting received a verbal blast from Ralph Smith; his feelings were that the problem has been skirted around for a number of years and no real progress had been made. This is an area where there are significant arguments over the effectiveness of the existing criteria at prediction of PIO and even the database upon which the criteria have been based. This latter view is not generally shared, and the consensus of the workshop rather pointed in a different direction. Nevertheless, within this presentation there is food for thought and the technical information deserves consideration.

In his presentation, which is self explanatory, Ralph Smith expressed a number of concerns which found accord with members of the audience, especially when he suggested that all FBW aircraft should be designed to be proof against PIO, whether for military or civil application.

Ralph Smith presented the concept which summarises the conditions which are necessary for the PIO to occur. The PIO process involves elements of aircraft dynamics, closed loop control and a "trigger". This latter is the item which can suddenly cause the pilot to increase his gain to the point that the total loop is driven unstable. He described a simple model based upon a synchronous pilot whose response to an aircraft state variable is of the form of a simple "bang-bang" input, combined with a dead space and a delay. With this simple model, in which the aircraft dynamics are represented by a transfer function, if a limit cycle is encountered, then the interpretation is that a PIO is likely to occur in flight.

Chic Chalk proposed that the pilot input would be synchronous with the crossover of the rate response through the zero, which corresponds to the attitude starting to move in the opposite direction. Such concepts were supported by John Gibson and others.

Ralph Smith noted that it is possible to have aircraft with adequate "performance" whilst having deficient handling qualities, and that this then placed heavy demands on pilot training and costs of operation in service, when such a combination occurred. A specific comment related to the behaviour of trainee pilots, which could be very different with respect to their gains employed, until they were familiar with their tasks.

There was debate as to what might constitute a trigger and whether or not it had to be the pilot or the control system which would constitute it. But the view was also expressed that maybe it does not matter what it is, there will always be one waiting to catch the unwary under some circumstances which will be found under the right conditions one day.

In the discussions, the Space Shuttle was cited as an excellent example of an aircraft for which this was the case. It fails to meet all the available design criteria with regard to resistance to PIO and does have a tendency for PIO unless handled very carefully by experienced, trained pilots. The difficulty arises because the PIO susceptibility is difficult to assess. The essential element of the process which needs to be followed up is to ensure that the control system is adequately stressed during its design and development, using whatever facilities can be thrown at the problem, even if this means flying tight control manoeuvres and in a way which may or may not be realistic of normal pilot activities in flight.

4.3.2) Unified Criterion for ACT Aircraft Longitudinal Dynamics

Roger Hoh indicated that the USAF is pursuing the PIO issue actively and is encouraging R&D on a joint basis with a number of researchers.

He stated that the phase lag at the crossover frequency was a key parameter in understanding the sensitivity or susceptibility of an FCS design to the possibility of PIO. His presentation showed how new criteria based upon phase lag were developing following the debates which had been held by AGARD Working Group 17, which are reported in reference 2. He was at pains to point out the benefits which had accrued by extending the discussion into an international forum; all involved had benefited from sharing of experience and ideas.

Most of the more recent developments with regard to design criteria stem from the activities of Working Group 17, noted in reference 2. This document also provides a good background for anyone new to the Handling Qualities arena and who wishes to quickly acquire a level of understanding of the overall problems which are present, especially with a modern highly augmented aircraft flight control system.

The concepts associated with phase delay would appear to capture the essential characteristics of the frequency response enabling an accurate assessment of PIO susceptibility, especially when the phase "roll-off" is taken into account. This latter term relates the rate of change of phase at the 180° crossover point to the susceptibility to PIO.

A clear message from this presenter was that care was needed if the aircraft featured a control system strategy which does not mimic that of a classical stable aircraft controller. In such circumstances, the Low Order Equivalent Systems approach was seen to be deficient with its ability to analyse the aircraft, particularly for PIO.

The view was expressed that whatever criteria was developed, it would have to account for the shape of the frequency

response curve, and that how the gain and phase varied around the crossover point is as important as the actual gain at 180° phase. The "Phase Delay" concept captured this nicely, and could even account for rate limiting by its effects on the shape of the frequency response curve. When combined with the "Dropback" criterion proposed by John Gibson, the results were very encouraging.

The presentation concluded with an assessment of the T-38 PIO incident, examining the effectiveness of the criteria which are available for prediction of PIO susceptibility. The results were somewhat varied and resulted in a heated debate regarding the validity and how the criteria had been applied. This served to illustrate that, at present, there is still some way to go, as each criterion would appear to be effective in the hands of the inventor, but problematic in the hands of others.

The subject of the feel system drew some debate. The tactile cues received by the pilot do include both force and motion and there is a suspicion that sticks which rely only on force detract from the handling. This is again an area of major debate, and it is not clear whether the problem is really one of having pilots learn to cope with a new philosophy, whether there are undesirable tactile effects or whether a combination of the two applies.

Dave Moorhouse expressed the view that the feel system, if well designed, should be transparent to the pilot. If not well designed, then it could be a major source of problem. Certainly, poorly designed feel systems have been major contributors to handling problems in general and PIOs in particular.

4.3.3) Looking for the Simple PIO Model

John Gibson highlighted that one problem was the gap which occurs between aircraft projects and the influence that this has on keeping expertise current and on the ability to learn the lessons from the past without repeating the same mistakes. Perhaps this further highlights the need to keep design teams current; use of aircraft demonstrator projects was seen as a possible way to maintain expertise and ensure the lessons of the past are not lost to each successive generation.

He described the development of criteria based upon the phase rate/phase delay concepts. His comments on the F-8 PIO trace, which he had not seen until the meeting, indicate that the trace developed as he would have anticipated, with a clear decrease in frequency as the amplitude of the oscillation increased, due to the effects of actuator rate limiting. The trace supported his ideas regarding the development and symptoms of PIO, confirming the synchronous behaviour of the pilot with the aircraft attitude.

The YF-22 traces show the same effects, although the initial trigger for the response might not have been the pilot, but was somewhere in the aircraft itself. The pilot commented that he felt "disconnected from the stick".

In developing his approach to designing out the high order rigid body PIO, the LAHOS data base had been used,

although this does not include non-linear effects. This had resulted in examination of the Phase Delay (or Average Phase Rate, which is the same number) around the crossover point, coupled with the frequency at the crossover. The gain at this point is important. Clear boundaries were identified, gradeable as Level 1, 2 or 3, which had been subjected to vigorous simulation exercises over the last three years. This was despite the apparent scatter to be found in the Level 2 data contained within LAHOS. Use of high and low order effects can be used to distinguish the cases required for the analysis.

The choice of the boundaries was worked up from simulation results, and experience showed that these seemed to be suitable and effective. They have been supported over a number of years by the work performed on flight demonstrator aircraft such as FBW Jaguar and EAP. A brief experiment performed on the Calspan Lear Jet had enabled confirmation, in part, of the concepts in flight, as the experiments yielded the predicted answers.

The use of phase delay is particularly liked as it can account for the effects of rate limiting via the influence on the shape of the frequency response. It details the phase lag in the problem area. This also applies to amplitude effects, which can also be investigated.

The clear message from this work is that the process must be to design for Level 1 handling qualities and then stress the flight control system to examine its behaviour under high pilot gain conditions, for a range of input amplitudes. If the aircraft can only oscillate at high frequency, then the problem is solved as the amplitude cannot be large. In response to a question, John Gibson stated that it does not matter what causes the violation of the absolute criteria.

PIO and Handling Qualities design are separate assessments and should be treated as complementary, rather than simultaneous tasks.

4.3.4) Experience of the R.Smith Criterion on the F-15 SMTD Demonstrator

Before making his presentation proper, Dave Moorhouse added some information regarding the YF-22 incident. The aircraft was making a second low pass over the runway with very little pilot activity when the event commenced. The trigger was within the aircraft, as the selection of the gear was made. He concluded that **there is always a trigger** and that the only way to proceed is to **fix the system**.

As a manager, he stressed that part of the problem is the seeking of a yes-no answer and that what was not needed was the advice from specialists arguing over whether or not there is a problem. His experience was generated from application of the R.Smith criteria as an absolute to both the F-22 and the F-16 MATV aircraft. This had shown the effects of the added thrust vectoring capability to be zero. He reported that there would be a paper published at the AIAA conference on the subject of the effects of rate limiting seen in flight of the F-15 SMTD aircraft. He recommended that people involved in assessing PIO should utilise the R.Smith criterion, but should

modify their application of it. The key to understanding the sensitivity of a design was to set up a task which would adequately stress the system, for example by setting up an HQDT type task for a landing approach condition. In the case of the F-15 SMTD, this had not revealed the problems indicated by the criterion.

A debate followed, predictably, regarding what had occurred and whether or not there had been a problem.

(Editor's Post-Meeting Note: This discussion resumed at the AIAA meeting in August, 1994. As a result of the comments made at Turin, Dave Moorhouse had reviewed all of the F-15 SMTD data and had found the undesirable characteristics which had been reported by Ralph Smith. He also reported that he was previously unaware of the information).

4.3.5) The Relation of Handling Qualities Ratings to Aircraft Safety

John Hodgkinson showed the work which he is undertaking to relate the handling qualities rating to aircraft safety. Another clear message is that the managers must be made aware that the presence of Aircraft-Pilot Coupling is a safety related issue, and is at least as important as structural integrity. (There is a suspicion that more accidents occur due to APC or PIO than due to structural failure!).

It could be shown that the Cooper-Harper ratings could be correlated with probability of aircraft losses, with CHR 6 corresponding to a probability of loss of 1 in 10^{-3} and CHR 3.5 corresponding to a probability of loss of 1 in 10^{-9} , or effectively not within the fleet life of the aircraft.

A comment was also passed regarding the C-17, where, during the development of the aircraft, a rate limit had been applied to the tailplane, and a pitch PIO had been forecast and occurred.

4.4) The Adverse Influence of Actuator Rate Limits

One of the major contributions to catastrophic PIO events is that due to actuator rate limiting, as noted in the opening presentation by Duane McRuer and Rogers Smith. The effect of rate limiting is to add further phase lag between the pilot command and the aircraft response and to reduce the frequency of the crossover point. A number of the events in the introductory video featured rate limiting, most notable recent examples being the JAS-39 and the YF-22 accidents. Rate limiting also featured in the Shuttle, YF-16, Tornado and many other major occurrences of PIO.

The modelling undertaken by BAe arose from the incidents with Tornado (MRCA), where rate limiting and acceleration limiting in the actuator played a major part in the incidents. Subsequent work led to very detailed investigation of the actuation system, as there continued to be surprises from this piece of equipment, which eventually led to some modifications in the flight control system of the aircraft. The

work identified the extra phase lags which can result very abruptly once the actuator rate limits.

The alternative approach to rate limiting, as proposed by Ralph A'Harrah, whereby the actuator control loop incorporates additional logic to command the reversal as soon as the command reverses is clearly very beneficial, but does require some care in its implementation, in order to correctly match input and output, once the high rate demands cease.

Ralph A'Harrah recommended that the actuator rate capability should be allocated by the function to be fulfilled, not by the displacement that has to be achieved. Use of this latter can lead to the effect of freezing the pilot out of the control loop.

4.4.1) SCARLET: DLR Rate Saturation Flight Experiment

A number of presenters reported work upon a strategy whereby the effects of rate limiting could be mitigated or even removed. The basic strategy concept was developed by Ralph A'Harrah, but experiments have been carried out at Calspan, at DLR Braunschweig and other centres to examine the benefits which might accrue. The object is to eliminate the undesirable effects of the additional time delays which rate limits add to the control system.

The first presentation on this subject to the Workshop was made by Jennifer Martin, who is currently working at DLR Braunschweig. The presentation described the testing performed on an actuator alternative control strategy which causes the actuator to reverse immediately the input demand reverses, rather than waiting for the actuator to reach the demanded position before reversing.

The main benefit of the strategy, tested as the Project Scarlet on the ATTAS in-flight simulator during 1992, is the removal of the adverse phase lag effects due to rate limiting. The testing performed showed that even with the actuator in rate limit, the control movement followed the demanded input much better than with that in the case without this modification to the actuator loop. PIO was successfully prevented, whereas without the modification, a PIO did occur. The experiments progressed to examine the effects with a Rate Command, Attitude Hold control system, again showing the benefit of having the actuator follow the command. These flight experiments are continuing.

4.4.2) SAAB Experience with PIO

The presentation by Per-Olov Elgerona and Erik Kullberg is very significant in this respect. They reviewed the past experience in Sweden with PIO, and indicated that the JAS-39 system originated from demonstration work performed on a FBW Viggen aircraft. Although this was reported to have experienced Level 2 or 3 handling, due to excessive time delays, it never experienced rate limiting or PIO.

Rate limiting played a very significant part in both accidents to the JAS-39 Grippen. The first accident was described as a design error, in that the design was known to be sensitive

prior to flight. However, the process did not catch up with the evidence and require modification before flight.

The first accident started as a response to lateral turbulence with a control system which augmented the dihedral effect, making the aircraft very sensitive in roll. More than one presenter, who had been involved with Saab in the subsequent work, commented that the JAS-39 "mini-stick" probably had a very significant effect, as it requires only very small movements to demand full control and had a skewed axis. Once the rate limits were reached, the PIO developed initially in roll, then in pitch. Modifications to reduce the gain, which also reduced the manoeuvrability, were introduced and the aircraft was assessed using a HQDT test. Using results of this a criterion was developed which allowed the margins from rate limit to be established.

However, as development progressed, there was a desire to boost agility at lower speeds and modifications were introduced. Assessment showed that under extreme conditions, using full roll and pitch stick, rate saturation and departure from stabilised flight could be reached. However, the decision was taken to continue.

The second accident featured a roll PIO as the pilot aggressively rolled wings level to accelerate in front of the crowd watching the aircraft at the Stockholm water festival. The subsequent response and pitch up to high AoA caused the pilot to eject after 5.9 seconds, fortunately without causing any harm to those on the ground or the pilot.

The solution being implemented on the JAS-39 is similar to that proposed by Ralph A'Harrah and tested in the Scarlet experiment at DLR and also on the Calspan Lear Jet. This works well to reduce the phase loss due to the actuator, but needs careful blending of the signals to avoid further problems due to the actuator not being at the demanded position.

4.4.3) Development of Handling Qualities Criteria Including Rate Limiting

Dietrich Hanke, of DLR, had assessed the impact of rate limiting and the alternative control strategy on the aircraft handling qualities, with a view to defining possible new criteria for use in design and assessment of such systems. A Model was developed allowing the effects of actuator rate limiting to be described in the frequency domain, from which appropriate handling qualities criteria can be derived. Using describing functions, he had arrived at a margin between the bandwidth of the system and the onset of rate limit, which he titled the "Amplitude Margin".

His work clearly showed the effects of rate limiting, with the cliff-edged behaviour apparent as the frequency reaches that for onset of rate limiting, for a given amplitude of input. Clearly, amplitude and frequency effects will need to be accounted for in any new handling qualities criteria.

4.4.4) Calspan Experience of PIO and the Effects of Rate Limiting

Chic Chalks personal experience of PIO is considerable, following a long standing interest in the subject over most of his working years. During this experience, the major concern that he has uncovered is that of the attitude towards the pilot following a PIO incident. There is still a tendency to consider a PIO as a failure of the pilot, whereas it must be properly regarded as a failure of the control system and its design process.

Over a period of some years, the Calspan Corporation have undertaken a series of experiments with the NT-33A and Lear Jet aircraft to examine the effects of rate limiting compensating devices. During these experiments, the results have shown that, when rate limiting is present, the pilots will tend to adopt a simple non-linear, "bang-bang" mode of control, which is keyed by either the zeroes on the rates or the attitude peaks.

If the trace of the DFBW F-8 aircraft is examined, then the correlation between the zero crossings of the pitch rate with the "decision" event can be clearly recognised. Eventually, the result is a constant amplitude motion with a "bang-bang" pilot response. The slope of the stick response relates to the feel system, but the "decision" point is when to reverse the response direction.

All of the PIOs which had been examined seemed to feature this behaviour. The default is perhaps contained within the pilot's brain.

Modelling of this behaviour using a Simulink package was described, and the results clearly indicate a decrease in oscillation frequency as the input amplitude is increased. With this model, it was possible to examine which terms influenced the response of the aircraft. From this study, rate limiting has a very clear influence on the frequency. A PIO prone aircraft has a lower frequency than a good aircraft, the consequence is that as the PIO frequency is approached. The characteristics are the same as shown by Ralph Smith's model.

Using such a model, it could be possible to define a design criterion along the lines of if the frequency at the crossover point is less than 4 rad/second, then there will be a problem if the response grows. Such a model can be used to discriminate between good systems and PIO prone systems.

4.5) An Investigation of Pilot Induced Oscillation Phenomena in Digital Flight Control Systems

In one of the final presentations, we were brought back to the possibility of the pilot coupling with the elastic modes of the aircraft. Duane McRuer had already indicated that this coupling with higher dynamic modes had been responsible for the loss of several CH-53 helicopters, particularly with underslung loads.

This presentation centred around the coupling of the pilot with the structural modes of the airframe. A number of examples were quoted, the most notable being the F-111

when carrying heavy external store loads under wing. When the pilot made an abrupt roll input, this excited the wing bending and torsion, which due to its low frequency and the effect on the response, he tried to oppose. He recognised the coupling, so clamped the stick, whereupon the aircraft shook both him and the stick.

This was referred to as a "Pilot Assisted Oscillation" or perhaps a "Pilot Augmented Oscillation". He let go, and due to the out of balance, the stick travelled stop to stop!

A further example was that of a large transport aircraft, in this case the C-17. Excitation of the wing frequencies, in a somewhat similar manner to the F-111, had coupled with the pilot's stick inputs, causing a "ratcheting" effect on the response of the aircraft. A brief paper describing these effects was made available prior to the workshop and is contained in reference 5, which will be included in the full report of the Workshop which will be prepared for AGARD over the next few months.

5) Conclusions

During the week of the ACT Symposium, of which the Workshop was the final part, a number of persons expressed their concerns with this problem in connection with the large transport aircraft, where the sheer size of the aircraft will place the structural primary modes within the frequency range of both the pilot and FCS.

This is clearly an area where there could be increasing concern and activity, if safety records are to be maintained in line with current expectations, particularly of the travelling public.

The clash of results from the different criteria currently in use is probably one of the main problems associated with getting management backing for the necessary design changes at an early enough stage. Often the technical arguments are clouded by arguments about whether or not the criteria used really apply. What should be considered is what is actually happening.

Theory and empiricism may still be the best way to judge the problem in a consistent fashion, despite the possible drawbacks. The key is to have it applied with the full background of engineering experience, using a team of engineers with an established track record to adequately "stress" the control system and ensure that the possibilities are addressed adequately. The use of the simple "bang-bang" model to excite the system should enable the designer to examine the behaviour somewhat more rigorously than has been the case to date.

The mere fact that there is a possibility of coupling should be enough to say that a change is needed as the problem will occur sometime, under the right stimulus. The design objective should then include ensuring that there is no possibility of the pilot coupling with the aircraft in a way

which could lead to significant oscillation with a large amplitude.

There are a number of conclusions which can be drawn from the data presented and the discussions which occurred at the Workshop:

1. **The term PIO places an unwarranted emphasis on the pilot**, when the problem is actually due to the flight control system design.
2. The phenomenon is perhaps better named **Aircraft Pilot Coupling**, thus avoiding the stigma which might be attached to the pilot by the unknowing and uninitiated. However, not all the attendees subscribed to this concept or nomenclature.
3. **PIO or adverse Aircraft Pilot Coupling is one result of the design process failing**
4. **The "design process" objective should be the achievement of Level 1 handling qualities and freedom from undesirable PIO or APC.** It should be noted that these objectives are not necessarily met by just considering either one or the other. **They must both be examined rigorously.** It is not sufficient just to design to achieve Level 1 handling qualities.
5. The design team who will implement the process should **include FCS designers, handling qualities experts, simulation engineers, test pilots and project management**, to ensure proper and effective communication and ownership regarding possible development events.
6. In the design process, every effort should be made, using whatever criteria are decided upon, to **search for the problem** and to **"stress" the flight control system design adequately** to ensure the problem has been designed out.
7. **The use of a simple "bang-bang" pilot model** to examine the behaviour of the system under varying input amplitudes is an essential aspect of "stressing" the system design.
8. **Adverse APC should be designed out** not avoided by requiring the pilot to fly the aircraft in a very controlled manner. This can never be relied upon under all circumstances and will almost inevitably catch the design out some day.
9. **Large transport aircraft should be designed to meet the same handling requirements** as military fighter aircraft, whether for military or civil application.
10. **Care is required before passing to a flight test stage in the event that there are aspects of the aircraft response that are not understood.** It is necessary to completely understand unexpected happenings which might occur during analysis, simulation - both manned and non-real time, rig test, etc.
11. **Remember that Murphy's Law applies, i.e. "If it can happen, it will happen".** The design process should recognise this, not only as a technical problem, but also as a management problem. The

management obligation is to **listen, understand and act** accordingly.

12. Aircraft-Pilot Coupling probably accounts for more aircraft incidents and accidents than does structural failure. **Never rely on the adage, "the pilot never will fly that way"! He probably will, given the "right" circumstances.**
13. Control System design and development will remain a **"Discovery Process"**. This should be recognised and the whole design team should recognise this and plan to be flexible in their approach.

6) Recommendations

The first recommendation is that the term **"Pilot Induced Oscillation"** should be either be avoided and replaced by a name such as **"Aircraft Pilot Coupling"**, or it should be recognised as not being the fault of the pilot.

The term should be explained and all associated should be educated to understand that it is not a "pilot cause" which can be removed by training, selection, or whatever. It is accepted that the pilot is involved in closing the loop that causes the instability, but the phenomenon is essentially a control system design failure. The current popular understanding attaches blame, even if inadvertently, where there should be none.

The second recommendation is that **the processes involved in the design, qualification and certification should be re-examined. PIO or Aircraft Pilot Coupling obeys Murphy's Law, i.e. if it can happen, it will happen.**

It is no defence to say "the pilot will never fly that way". It may be improbable, but not impossible. The design process should set out to positively search for signs of Aircraft Pilot Coupling problems in the design process and act accordingly if they manifest themselves.

Finally, the Flying Qualities community should seek to arrive at one set of universally accepted criteria to describe and evaluate the sensitivity of a design to Aircraft Pilot Coupling.

At present, there are a number of criteria which may be partially successful, with some of the latest ideas looking very promising. It would be productive to seek the common ground rather than concentrate on the differences all the time. From the discussions which took place at the Workshop, it is clear that there are a number of possible approaches to the problem. It is important to share ideas, and the AGARD meeting has once again facilitated this, as it did for Handling Qualities with Working Group 17.

7) **References**

1. Duane McRuer,
"Human Dynamics and Pilot Induced Oscillations."
22nd Minta Martin Lecture, December 2, 1992,
M.I.T.
2. Wunnenberg, H. et al;
"Handling Qualities of Unstable Highly Augmented
Aircraft".
AGARD Advisory Report AR279.

Acknowledgements

To Mr. Peter Sully, Department of National Defence, Canada, for proposing the original idea for the Workshop and Mr. Stewart Baillie, Flight Research Laboratory, N.R.C., Canada, for his assistance in finalising the proposal.

To Mr Franco Sella and Prof. Fulvia Quagliotti for providing the opportunity and facilities to hold the Workshop and to the Students of the Politecnico of Turin for their assistance.

To all the presenters and contributors to the Workshop, but especially Per-Olov Elgcrona and Erik Kullberg for sharing their experiences with the JAS-39 so readily and openly, that all workers in this field may benefit from their unfortunate experiences.

PIO - A Historical Perspective

presented by
Mr. Duane T. McRuer
Chairman, Systems Technology, Inc.
357, S. Meadows Ave.
Manhattan Beach, CA 90266
United States

&

R.E. Smith
NASA, Dryden

Introduction

These problems relating to Pilot Induced Oscillations have manifested themselves since the earliest days of manned flight. The earliest recorded examples of PIO date back to the Wright brothers first aircraft. The earliest filmed records date back to just prior to World War II, with the XB-19 aircraft which suffered a pitch PIO just prior to touchdown.

Four classes of PIO have been identified, into which all of the known incidents can be fitted. These are:

1. Essentially Single Axis, Extended Rigid Body Effective Vehicle Dynamics.
2. Essentially Single Axis, Extended Rigid Body with Significant Feel-System Manipulator Mechanical Control Elements.
3. Multiple Axis, Extended Rigid Body Effective Vehicle Dynamics.
4. PIOs Involving Higher Frequency Modes.

Historic PIO Incidents and Their Lessons

The video clips which accompanied this presentation, illustrate a number of these different PIO categories, starting with the clip of the XB-19 pitch PIO on landing.

Reference 1 presents detail descriptions, or specific references, for the PIO incidents which were referred to during this presentation. Tables 1A to 1C provide a brief synopsis of the major aspects of the incidents, whilst the notes which follow provide additional comment. Some of the incidents described in the tables were included in the video clips presented during the discussion.

In the case of the XF-89, which suffered a PIO in pitch during a dive recovery, the chosen solution was to change the test pilot for the trials, to one with a lower gain and more relaxed flying technique. As a result, this incident was not repeated during the testing.

The YF-12 incident is of interest. The aircraft was a forerunner of the SR-71A aircraft, and features a very long slender fuselage, being designed for sustained high supersonic cruise conditions. This represents one of the earliest cases of the pilot interacting with the flexible aircraft dynamic behaviour. This aircraft also exhibited an early example of a severe category III PIO wherein the effective aircraft dynamics presented to the pilot were affected by the amplitude of the pilot's inputs.

In the case of the MRCA, the two incidents resulted from an initially overgeared system, but the subsequent response was dominated by the adverse effects arising from the actuation

Summary of Video Sequences

■ Shown by D.T.McRuer

- XB-19 Circa, 1941
- F-4 Low altitude speed record attempt, White Sands, 18.5.1961
- YF-16 First flight, Fort Worth, 1974
- ALT-5 Space Shuttle, Enterprise, Edwards, 26.10.1977
- F-8 DFBW NASA Dryden, 18.4.1978
- YF-22 Edwards, 25.4.1992

■ Shown by R.E.Smith

- JAS-39 Linkoping, 1990
- JAS-39 Stockholm, 1993

system rate limiting, resulting in a large amplitude pitch motion and loss of control just prior to touchdown.

Because of its high visibility, the PIO on the Space Shuttle ALT-5 flight has probably contributed more to PIO research than any other single incident. As the first landing of a shuttlecraft on a normal runway, the pilot was correcting for a higher than expected energy state while simultaneously engaged in very tight precision closed-loop control. Initially there was a mild lateral PIO, followed by a longitudinal PIO. The latter involved oscillations at two frequencies, corresponding to path and attitude modes. After analysis, the fundamental culprit in the effective dynamics was found to be excessive effective time delay (greater than 0.25 sec.). With such large lags, the emphasis on the pilot is stay out of the control loop as much as possible, using intermittent, pulse-like corrections when needed. The video clip, which was filmed from some distance away, clearly shows the PIO start and progression, even from a distance.

For the B-58, in the case of the yaw damper being lost, the aircraft became very difficult to control. This was an early example of the "omega phi/omega d" effect in lateral control; unfortunately leading to a fatal crash.

The M2F2 Lifting Body produced a series of PIO incidents during its test career.

The CH-53 has exhibited a range of non-rigid body modes which have resulted in PIO. These have occurred over a period of time and frequently involve the motions generated

by the underslung loads. Frequently, in such cases, the result is the loss of the load from under the helicopter.

As an early fly-by-wire, sidestick controlled, aircraft, the lessons from the YF-16 are significant in several ways. During the high speed taxi runs before the scheduled first flight, the pilot began to rock the wing from side to side to gain a better appreciation for the aircraft. This was his practice from flying production test operations on the F-111 aircraft. For the YF-16, where the sidestick was essentially force-sensitive, this rapidly became overcontrol, developing into a PIO. In a wonderful feat of airmanship, the pilot chose to become airborne to regain control of the aircraft. In this case, the PIO was first seen in the in-flight simulation performed in the NT-33A aircraft. However, this was overlooked as the aircraft was prepared for flight. Again, the video recording shows the onset of the motion and the subsequent divergence that occurred

Excessive time delays resulted in the F-18 having a PIO, following which the aircraft was forbidden to undertake carrier landings or formation flying until the fix for the delays was developed and incorporated.

The YF-22 incident arose when the pilot brought the aircraft into a condition which had never been evaluated before. The incident occurred whilst flying a low approach and overshoot for the second time in front of the gathered pressmen. The mode was such that the pilot made a more aggressive forward stick input, raising the gear at the same time, which influenced the response via a discrete gain change and caused an excessive nose down pitch. The view downwards from the

Table 1A - Famous PIOs

- Longitudinal PIOs - Extended Rigid Body
 - XS-1 PIO during gliding approach and landing, 24 Oct 1947; NACA pilot Herbert Hoover
 - XF-89A PIO during level off from dive recovery, early 1949; pilot Fred Bretcher; Large amplitude Category I PIO
 - F-86D PIO during formation flying when pulling Gs; Category II PIO
 - F-100 PIO during tight manoeuvring
 - F-101 Aft c.g.
 - X-15 Gliding flight approach and landing, 8 June 1959; pilot Scott Crossfield; (NASA TM X-159, Sept, 1959, Finch & Matranga, NASA TN D-1057, July 1961, Matranga) Category II PIO
 - Sea Dart Post take-off destructive PIO
 - YF-12 Mid frequency (Category III PIO) & high frequency flex mode involvement (Category I PIO)
 - MRCA Short Take-off, 1975; Heavy Landing, 1976
 - Shuttle ALT-5 during landing approach glide, 26 Oct 1977; pilot Fred Haise; both attitude and path modes involved; Category II PIO
 - FBW F-8 PIO during touch and goes, 18 April 1978; pilot John Manke; Category III PIO
 - YF-22 PIO during low approach and wave off in afterburner, 25 April 1992; pilot Thomas Morgenfield; Category III PIO
 - JAS-39 PIOs during approach, 1990; PIO during demonstration, 1993; Category II & III PIOs

cockpit is exceptional, causing the pilot to be aware of the change of attitude at low level. This resulted in a stick reversal. In response to the question as to why the pilot did not break out of the PIO loop, he stated that he thought something had broken and had not recognised the PIO, the rate limiting effects having detached him from the aircraft.

The last examples shown on video were the two incidents which occurred with the JAS-39 Gripen. The first accident happened during a landing approach in gusty conditions. The roll activity put the actuation into rate saturation, and the motion transferred from roll to pitch, just prior to touchdown. Loss of control ensued and the aircraft ended by rolling over following a combined roll and pitch demand from the pilot.

The second accident, which occurred during the Stockholm Water Festival, again started following a rapid stick input, which caused rate saturation and the PIO rapidly diverged into a pitch up to very high AoA, at which point the pilot ejected. The time from loss of control, the start of the PIO, to ejection was of the order of 5.9 seconds.

It is considered that in this case, the stick dynamics may have contributed significantly to the problem which the pilot encountered.

A full background into the causes and effects of PIO is also contained in reference 2, which deals with the handling qualities of highly augmented aircraft.

Pilot-Behaviour-Theory Based Categories for PIO

In severe PIO cases, there is always a precursor, i.e. some unusual set of circumstances which lead to the aircraft being in a sensitive situation. Then follows the "trigger mechanism",

i.e. that which actually causes the PIO to break out on this occasion, when it did not on maybe several hundred other times at the similar condition. Finally, there are the pilot mode "shifters" which cause the response of the pilot to change, to a synchronous or "bang-bang" control mode.

Studies of the pilot behaviour in the severe PIOs show changes to the pilot behavioural characteristics, and there are detectable changes in the pilot-organised system pattern and the pilot-pattern transitions. Along with these effects, it is possible to detect the Controlled-Element dynamic transitions, from FCS and aircraft configuration shifts and the sensitivity to the pilot input amplitude.

Three categories for the PIOs can be derived based upon the pilot behaviour:

- Category I - Essentially Linear Pilot-Vehicle System Oscillations.
- Category II - Quasi-Linear Pilot-Vehicle System Oscillations
- Category III - Essentially Non-Linear Pilot-Vehicle System Oscillations with Transitions.

The Design Process

One of the main concerns which arises from the past experience relates to the failure of the design processes involved in the FCS development activities. There is plenty of evidence, as shown, for this failure, but what is behind it?

The process starts with the design criteria and the analysis which is performed using these criteria. Perhaps there are

Table 1B - Famous PIOs

- Lateral-Directional PIOs - Extended Rigid Body
 - KC-135A Mild Lateral-directional PIO associated with omega-phi/omega d, late 1950s (AFFTC TR-58-13)
 - B-52 Roll PIO while refuelling
 - F-101B Lateral PIO at high q, subsonic (AFFTC 58-11)
 - X-15 Lateral PIO, 1961; (NASA TN D-1059, Nov, 1961), Category II PIO
 - Parasev Paraglider Research Vehicle lateral rocking PIO during ground tow, 1962; pilot Bruce Petersen
 - B-58 Lateral-directional control associated crash, Sept 14, 1962; pilot Ray Tenhoff
 - M2-F2 Lifting Body Lateral-directional PIO, 10 May 1967; pilot Bruce Petersen (NASA TN D-6496)
- Longitudinal PIOs - Extended Rigid Body Plus Mechanical Elaborations
 - A4D2 High speed PIO, circa 1957; Bobweight and primary control system involved; Category III PIO
 - T-38 High speed PIO, 26 Jan 1960; Category III PIO
 - F-4 Low altitude record run second pass, 18 May 1961; pilot Cmdr Jack Feldman, RIO Ens Hite; Destructive PIO

Table 1C - Famous PIOs

- Lateral-Directional PIOs - Extended Rigid Body Plus Mechanical Elaborations
 - A-6 Lateral effective bobweight effects; Category I PIO
- PIOs Associated with Higher Frequency Non-Rigid Body Modes
 - CH-53E Airplane-Pilot Coupling with Flexible Modes; several major instances in precision hover and with heavy sling loads, including crashes, heavy landings, dropped loads, etc., 1978 - 1985; Extreme Category I to II PIOs
- 3D, Multi-Axis PIOs
 - X-5 31 March, 1952; pilot Joe Walker
 - YF-16 "First Flight", pilot Phil Oestricher, Category III PIO
 - ALT-5 Lateral PIO, just prior to longitudinal PIO; 26 Oct 1967; pilot Fred Haise
 - F-14 High Alpha, with some Beta; pilot Don Evans
 - AD-1 Oblique Wing

problems with the design criteria themselves, in that they do not represent the necessary conditions satisfactorily to ensure freedom from PIO.

Testing, both in ground simulators and, if possible, in airborne simulations must seek to "stress" the design adequately to ensure that any inherent problems are uncovered. It may even be possible to identify the trigger mechanisms from such stressing of the control system design.

Clearly, there have been examples where this stressing has been carried out, but the information gained has not been acted upon, probably because of programme timescale pressures. It is this failure of the design process which is in most urgent need of attention if the problems of PIO are to be satisfactorily resolved.

Conclusions

PIO has been a phenomenon of concern to both pilots and aircraft designers since the earliest days of flight. However, the severity and frequency of occurrence has increased with the advent of power flight controls and the use of Fly-by-Wire flight control technology. This stems from the effective increase in the time delays which these systems have the potential to introduce, with the consequence that they may "separate" the pilot from the control.

In almost all the cases in which the aircraft suffered severe PIO and loss of the aircraft, actuator rate limiting has played a major part. Once in rate limit, the actuator adds significant phase lag to the response very rapidly, such that it is impossible for the pilot to compensate for the effects.

The problem can be solved, and some design teams have demonstrated that this is the case. The key is to have the right tools, apply the chosen criteria correctly, stress the FCS design

properly and take account of the lessons which this provides for the design process.

Lastly, it must be recognised that the FCS design process will remain a Discovery Process, and that sufficient flexibility in the management and design team is an essential ingredient, such that the lessons which can be learned are incorporated in a timely manner. All involved in the process, from FCS design engineer, through handling qualities specialist, the test pilots to the team project management have a role to play in ensuring that the process works satisfactorily. Good technical communication is the essential prerequisite for success

References

1. Duane McRuer,
"Human Dynamics and Pilot Induced Oscillations."
22nd Minta Martin Lecture, Dec. 2nd, 1992, M.I.T.
2. H. Wunnenberg et al;
"Flying Qualities of Unstable Highly Augmented Aircraft".
AGARD Advisory Report 279.

The Process for Addressing the Challenges of Aircraft Pilot Coupling

Mr. Ralph A'Harrah
Manager, Flight Systems
High-Speed Research, RH
Office of Aeronautics
NASA Hq
Washington, DC 20546-0001
United States

1) Introduction

The term "Pilot Induced Oscillation" is misleading in that it places an undue emphasis on the role of the pilot in the process. Clearly, the phenomenon cannot occur in the absence of the pilot, but the term PIO suggests that the pilot is in some way responsible for the occurrence. **He is not.**

The phenomenon may be better described by the title "Aircraft-Pilot Coupling", or A-PC. This may be considered to better describe what is actually occurring when the pilot is trying to perform his normal function, i.e. that of controlling the aircraft which he is flying.

For a designer, the objective should be to ensure that there is no possibility of A-PC occurring. Associated with this, the goal should also be to achieve Level 1 handling qualities. The key is to understand the Process involved in design and test and to ensure that this is exercised to achieve the objective. This has to be set alongside the management goals of better, faster and cheaper, in order that the manufacturer can remain competitive in the market.

2) Aircraft-Pilot Coupling Issues

The key issue facing the design teams is how to arrive at an aircraft design which is free from adverse aircraft-pilot coupling. Associated with this is the issue of improving the flying qualities specifications to improve the effectiveness at

discrimination between satisfactory and adverse levels of pilot coupling.

This then raises the question of whether the approach should be proactive during the design, or reactive in the event of there being an incident or accident during the test of the vehicle.

Conventionally, the design process is confused by the lack of consensus which frequently exists between test pilot opinions and the effect this then has on the commitment and constituency of the team for elimination of the effects of A-PC. There are also questions as to whether the existing vehicles have a latent tendency to A-PC which has yet to be shown and which may defeat generalised treatments.

3) The Process Objectives and Means to Achievement

The process for addressing the challenges of aircraft-pilot coupling is considered to have the following major objective;

- No adverse A-PC characteristics combined with the achievement of Level 1 flying qualities.

To achieve this it is essential that both the Project Management and the A-PC elimination team must have the same objective. This also relates to the overall Management goal of *better, faster and cheaper*, and as such this concurs with the Total Quality Management aspiration of "right first time".

A-PC Workshop

Aircraft-Pilot Coupling Issues

- How to design/develop an advanced aircraft free of adverse A-PC
- How to improve flying qualities specification to provide improved effectiveness in discriminating between satisfactory and adverse levels of A-PC
- Proactive during the design/development, or reactive after the accident
- Lack of test pilot consensus/commitment/constituency on the elimination of A-PC
- Are catastrophic A-PC's lurking in the background of many aircraft, or isolated occurrences that defy general treatment

To meet the goal, there are three areas which must be considered, i.e. the Team to tackle the problem, the Tools to be used and, lastly, the A-PC Process itself.

3.1) The A-PC Team

The first requirement is the correct team composition, constituted early in the design process, and left to run with the task to its completion, with at least sufficient continuity to ensure that nothing is missed. In this way, it is important that the team itself decides when help is needed, not the manager. It is essential that the team is empowered to ensure that the process

runs through successfully to the achievement of the goals set out.

including ground based simulators and in-flight, variable stability simulators. Analysis techniques with which the team has experience and confidence should be used to back up this work, and this will undoubtedly provide the basic design evidence for any possible changes.

A-PC Workshop

A-PC Team

- A team formed at the conception of the program
 - Early definition of the full "Team" is recommended
 - facilitates the sense of "ownership" of the consequences of the groups actions
 - minimises the disruptive "reinventing" of the team to include new members
 - Additional outside experts to help with special challenges
 - done at the request of the team
 - based on a team perceived need
- A team empowered to define the A-PC process needed to meet the goal

However, it should be recognised that if, from their own knowledge, the team has something which it regards as better, and with which it has a proven track record, then it should be allowed to use it as a normal tool.

3.3 The A-PC Process

The process which will be followed most often is essentially iterative in nature. Frequently the first iteration is regarded as a practice attempt at the design. The iterations will continue until the team meets the goals which have been set for it. All of the tools will be employed in the process, and it is essential that the pilots are fully involved throughout the design activity.

The team should consist of personnel drawn from Test Pilots, Flying Qualities engineers, FCS Design engineers, Simulation specialists and, most importantly, a representative from the Project Management organisation, preferably at a level with executive authority. The team should have access to outside

The process is therefore one of starting with a set of design criteria, or specification, to act as a set of design guidelines, followed by simulation, then detailed analysis of the results.

A-PC Workshop

A-PC Tools

- Flying qualities specifications, such as MIL-F-8785C
- Ground based simulators
- In-flight variable stability aircraft
- A-PC research results considered by the A-PC team to be more effective than the specification
- Standard analytical/computational tools

Within the process, avoidance of adverse A-PC may be assisted by giving adequate consideration as to how the control functions are allocated between the control effectors. In this case, it may be more appropriate to allocate the rates of control movement by the function to be performed, rather than by the more conventional method of allocating the rates according to the displacements which are required. A consequence of failing to allocate the control functionality correctly is

help from recognised experts in the field, should this be required, but only at the request of the team based upon a perceived need for the assistance. It is also desirable that the Customer has either representation on the team or has very close liaison with the team, to ensure that there is understanding and ownership of the findings from the team.

3.2) The A-PC Tools

Probably the best starting point, which the team might consider for the tools to be used, is the Flying Qualities definition presented in Mil-F-8785C, although the team could actually start with any proven specification with which they have had previous experience.

Flight simulation is seen as the major component for the assessment and elimination of any adverse A-PC effects,

A-PC Workshop

Suggestions for A-PC Team consideration

- Take advantage of the guidance available from the Flying Qualities specification
 - Compliance is not the issue, because beating the Spec is not difficult
- For Fly-by-Wire Controls
 - The incremental time delay associated with the pilot's input exceeding the actuator rate limits should be included as part of the Mil-Spec time delay budget
- For multi-input controls
 - For unstable aircraft, to assure that the critical stability augmentation system input is not nulled by the rate or position saturation caused by other inputs
 - For allaircraft, to assure that the pilot's input is not nulled by rate or position saturation caused by other inputs
 - to minimise the elevon coupling associated with the pilot's control input being allowed to exceed 100% of the surface authority (causing an off-axis upset)

A-PC Workshop

Aviation Accident Information

- Commercial Aircraft
 - 1959 to 1990 data indicate a relatively constant 1.5 fatal accidents per million flights
 - 10 fatal accidents in 1989, 7 in 1985
 - 70 - 75% of commercial accidents were considered the responsibility of the flight crew
- General Aviation
 - 400+ fatal accidents per year from 1985 - 90
 - 80% of accidents are attributed to the pilot

the generation of out of axis inputs in response to control commands.

One of the key features to be examined and avoided is the pilot commenting that he feels frozen out from the control loop. This is usually a sign of impending disastrous behaviour from A-PC. In this respect, it is essential that the incremental time delay which can result when the pilot's input exceeds the capability of the actuator rate limit should be included as part of the Mil-Spec time delay budget. For Level 1 Handling, this time delay must be less than 100 millisecc. Compliance with the specifications should not prove to be too difficult. The key is to treat the specification as a set of guidelines and meet the intent. It is this aspect that may, and usually does, produce the most difficulty, as the designers need to understand the intention behind the specification rather than simply the rules which it declares.

4) Conclusions

From past experience, it can be concluded that the description of Pilot Induced Oscillations places an unwarranted emphasis on the role of the pilot in these events. Whilst it is clear that they can not occur without the pilot, they are not due to the pilot, but to a failing in the process for design of the system including the pilot in the control feedback loop. A better term for them would be **Aircraft-Pilot Coupling**.

The goal for any design team must be the avoidance of adverse A-PC effects. This is probably best attained by ensuring that the team designs the system to achieve Level 1 Handling Qualities. It is suggested that a specification such as Mil-F-8785C should prove to be an adequate starting point for this process.

The team to engage in the design process must be properly constituted with representatives from all of the disciplines that must contribute to the process. Included in the team should be FCS designers, Flying Qualities engineers, Simulation experts, Test Pilots and, perhaps most significantly, representatives of the Management Team and Customers. It is important that co-operation forms the basis of the team operation.

It is essential that the design is properly "stressed" during its development and assessment, i.e. the problems must be searched for using all possible tools and criteria with which the team is both familiar and comfortable and with which it has had experience of successful use in the past. The role of simulation cannot be overstressed in the pursuance of this goal, whether this be ground based or in flight.

Finally, if a problem is found then it is imperative that it is analysed, understood and a fix is designed before it enters into the flight test phase. The consequences of failing to do this have been well illustrated in the preceding presentation. In this context, it may be as important for the Managers to experience the problem at first hand, perhaps via the use of in-flight simulation in a real environment and under realistic conditions.

References

1. Mil-F-8785C
Flying Qualities of Piloted Airplanes.



Observations on PIO

Ralph H. Smith High Plains Engineering

1) Background and History

The presentation started with an analogy. Comparison of the handling characteristics of a Porsche with those expected from a modern combat type aircraft indicate that we accept significantly poorer handling performance with the aircraft than we would with a high performance road vehicle.

The work which led to the evolution of the Smith-Geddes criteria stems from work performed for the USAF in relation to the F-15 aircraft. The logic that arrived at the criteria stemmed from a belief that the existing handling qualities criteria were inadequate for assessing the PIO susceptibility of an aircraft, and that the only successful way to test for this was to use the methods of Handling Qualities During Tracking (HQDT). The work which was performed was offered for the update of Mil 1797, but was not incorporated.

In introducing himself to the audience, the presenter stated that he was not "a member of this church", and that his views were considerably at variance with the majority of those who might speak on this subject.

The presentation concentrated on the understanding of PIO and the process by which it originates, using a simple model to demonstrate the characteristics which are inherent. The presentation also provided an explanation of the Smith-Geddes criteria, without resorting to the detail of the theories which support the criteria.

The major thrust relates to the application to the assessment of PIO susceptibility and includes a commentary on the state of the control law development, together with the associated flight test technology, as perceived from the position of the presenter.

(Editorial Note - The slides which form the basis of the presentation are nearly self explanatory and the notes which follow are therefore derived from the transcription of the Workshop recording of the presentation and subsequent discussion.)

2) Comments on the Criteria and the Assessment Process

As noted above, the criteria proposed for the assessment of PIO susceptibility was derived in response to an Air Force Test Centre requirement for a reliable method with which to evaluate aircraft passing through their hands.

The presenter showed that his belief was that all FBW aircraft should obey the same Handling Qualities requirements, and that his real concern was aimed at the designs of commercial aircraft which featured FBW control systems. Specifically, it was considered possible that these aircraft were being designed PIO prone.

The presenter believed that when an aircraft failed to meet some particular criteria which might prove to be significant, then a possible way forward was to amend the criteria, rather than to identify the cause of the non-compliance and then fix it. He expressed the personal belief that this had in fact occurred in the past. The view was expressed that there was a significant improvement to be had from the Handling Qualities are by adopting an improved approach.

In assessing aircraft, the presenter's view was that specific testing for PIO susceptibility was avoided and that, at least in the past, the PIOs had been discovered by accident, rather than being deliberately sought prior to cure. The result of this approach was often an accident or incident. Poor handling qualities had been accepted as necessary adjunct of obtaining good performance.

Within the USAF test community, there had been a different approach adopted. The work undertaken there had been targeted at identification of the system dynamics and the test pilots had been trained to stay out of the control loop as far as is possible. In this way, they were better equipped to cope with PIO prone dynamic behaviour. It was also found that it was difficult to get a trained test pilot to close the loop in the same way as a Service pilot would.

It was the experience with working with test pilots that brought about the doubts in the presenter's mind with regard to handling qualities evaluations. This stems from the variability or subjectivity of a pilot's views, and indeed it is possible to obtain a range of comments from an individual pilot.

3) Understanding the PIO Process

Fundamentally, PIO is a simple process, although there are many issues related to it which will never be fully understood. A very simple model of the pilot behaviour could be developed of a "synchronous" or "bang-bang" type, where the pilot is modelled as responding in this manner to an observation parameter, such a aircraft attitude or normal acceleration.

The non-linearity involved in reality is extremely complex, but is probably not entirely relevant with regard to the specifications of what has to be achieved with regard to provision of good handling qualities and resistance to PIO. In this respect, the presenter expressed severe reservations with regard to the applicability of task oriented flying qualities and Cooper-Harper ratings as a means to ensuring the aircraft is free of adverse PIO characteristics.

Use of these methods was considered to hinder the resolution of the parametric effects which might be considered in the establishment of a design, or in the repair of a design. The alternative PIO rating might be acceptable, but did not fit with the concept of task oriented Flying Qualities tests. This stems from the difference between the assessment of closed loop stability and overall system performance.

Theory was considered to be a better way to diagnose possible PIO.

The simple model which has been evolved consists of a "bang-bang" pilot, with a threshold and a time delay, followed by a representation of the aircraft dynamics by an appropriate transfer function, or a simulator. The feedback could be various, e.g. normal acceleration, flight path angle, attitudes etc.

Using such a model, the results of which correlate with the PIO traces which arise from flight test, it was possible to define "go" or "no-go" tests for PIO. For a PIO to exist, this simple model must exhibit a limit cycle, at least. An example, correlated with flight, was shown for a roll response. Plotting the results in the phase plane, it was demonstrated that a reduction of the command gain would remove the instability and limit cycle tendency of this simple system.

One of the concerns which comes from the work presented and expressed by the presenter, is that a student pilot, because he does not have the training, is more likely to adopt a command strategy which approaches this simple model and hence may be more likely to run into the problems which result.

4) Application of the Criteria

The basic Smith-Geddes criteria has been applied by the Air Force Test Centre over some period of time and to many aircraft in the current inventory. Use of the criteria had predicted problems with the Shuttle, the B-2 and the C-17, all of which had experienced problems with PIO in some form. The presenter expressed his confidence with the criterion in the hands of a team of engineers who had been close to its derivation.

The same does not appear to have been universally the case when used by engineers who were not involved in the derivation, but only the application.

(Editorial Note - Clearly, from the discussion which ensued, there was a significant debate going on within the US regarding the effectiveness of the criteria, or perhaps the meaning of the results that were produced. Successes and failures to show what was actually happening were claimed, but without resolution of the arguments at this meeting.)

References

1. AFFDL TR-78-154
Handling Quality Requirements for Advanced Aircraft Design: Longitudinal Mode
Smith & Geddes
2. AFFDL TR-77-57
A Theory for Longitudinal Short-Period Pilot Induced Oscillations
Smith
3. AFWAL TR-81-3090
Notes on Lateral-Directional Pilot Induced Oscillations
Smith
4. AFFDL TR-75-119
A Theory for Handling Qualities with Applications to MIL-F-8785B
Smith
5. 1994 SAE Aerospace Atlantic Conference
Dayton, Ohio, April 20, 1994

Automobile Analogy

- This Porsche can be positioned within 25 mm of a desired point, lap after lap, under racing conditions
- If we were able to control our autos with no more precision than that possible with a modern fighter in power approach:
 - roadway lane widths would have to be 30 meters
 - our garage doors would have to be 15 meters wide
- The typical fighter can't repeatedly touch down within a 60 meter box without eventually breaking something
 - non-carrier landing aids

HPE

Handling Qualities of Current Operational Aircraft

- Most operational aircraft probably have significantly deficient handling qualities
- This does not prevent them from being effective systems, with acceptable levels of performance
- Handling deficiencies contribute to
 - excessive demands on pilot training & proficiency
 - the accident rate
 - more complex & costly subsystems (e.g. gunsights, HUD)
 - continuous process of FCS "fixes"—mostly software
 - increased life cycle costs

HPE

Observations on PIO

Ralph H. Smith

High Plains Engineering
Tehachapi CA 93561
USA
0091-805-821-1911

AGARD Workshop on PIO
May 13, 1994
Turin Italy

HPE

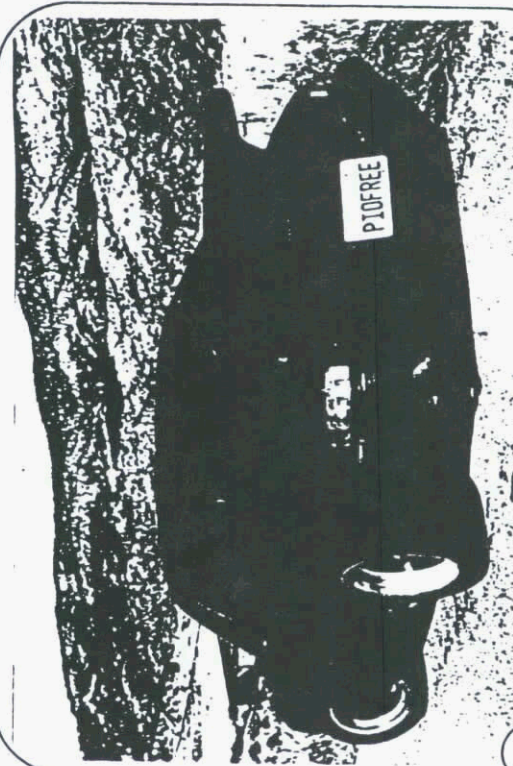

Official Test Vehicle, High Plains Engineering

HPE

Typical Handling Quality Flight Test--As Performed by the Research Community:

- Design a test, selecting desired and acceptable levels of performance, to facilitate use of the Cooper-Harper scale for pilot evaluations
- Conduct some preliminary tests; discover that desired performance "requirements" can't be met, even with "good" airplanes
- Redefine performance "requirements" so that "good" airplanes are rated as "good"
- Complete flight test; write research report; present paper in some neat vacation spot
- Result: Continue to be unable to understand why PIO occurs; get money for new tests

HPE

Flight Testing

- Aircraft are not adequately flight tested for handling qualities
 - Testing is done to verify contractual requirements, not for safety of flight assurance
 - Flight test expertise is shut out of the process until a safety of flight problem arises
 - » Not consulted for definition of requirements
- Manufacturer & program management:
 - When the design specification is met, the job is done
 - Cost & schedule can be quantified; PIO susceptibility is not

HPE

FCS Design & Development

- The process of FCS design & development is "broken"
 - we face a flight control crisis
 - FBW commercial transports are main concern; potential public safety hazard is real
- FCS design technology is unstructured
 - designs are ad hoc
 - no professional standards for designers
 - critical design decisions are not broadly reviewed
 - unbalanced focus on software implementation
- Specifications for handling qualities, however poor, are often ignored

HPE

Flight Testing (Continued)

- PIO testing is specifically avoided
- When design specifications are met, criticisms of handling quality deficiencies are not treated professionally
- Very strong tendency by pilots to overlook or rationalize poor handling qualities as the price to be paid for sensational performance

HPE

Flight Testing (Continued)

- **Technology community has ignored lessons-learned from flight test**
 - over-reliance on variability stability aircraft for criteria development
 - design of flight test experiments has been done in a vacuum
 - academic approach to understanding handling qualities
 - lack of critical thinking
- **Flight test lessons-learned haven't been well-documented**
 - political pressures
 - incompetent technology management
 - the good stuff never seems to get exposed

HPE

Understanding PIO: Three Necessary Conditions for PIO

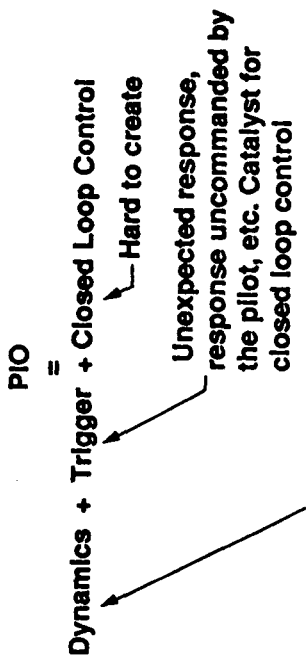

Smith-Geddes Criteria

HPE

Peer Review of R&D

- **What's to be done when the process breaks down?**
 - governmental control of the technology
 - no effective oversight
 - the "buddy system" at its worst
 - intolerance for new ideas
- **The good news: in the USA, government is not a monolith**
 - the flight test branch of government has, for almost 20 years, ignored the research community
 - consequence: there has been real progress made from flight test experiences with real airplanes

HPE

Recognizing PIO Susceptibility

- May take years, when not identified in flight test
- Misleading to base design criteria on aircraft having *no known* PIO problems in operations
 - most PIO from operations probably go unreported
 - three necessary conditions for PIO
 - statistical improbability in routine operations
 - statistics probably correlate with accident rate

HPE

Recognizing PIO Susceptibility: Subjective Evaluations

- Insufficient for PIO Identification
- Pilots are asked to do the impossible:
 - Cooper-Harper scale is deficient
 - flight test techniques are often flawed
 - task-oriented handling qualities - another bogus concept for the *Handling Qualities Hall of Shame*, along with "equivalent systems"
- Pilots are only human
 - pilots aren't always reliable evaluators

HPE

13

Quantifying PIO Susceptibility: The Smith-Geddes Criteria

- AFFDL-TR-75-119, A Theory for Handling Qualities With Applications to MIL-F-8785B, R.H. Smith
- AFFDL-TR-77-57, A Theory for Longitudinal Short-Period Pilot Induced Oscillations, R.H. Smith
- AFFDL-TR-78-154, Handling Quality Requirements for Advanced Aircraft Design: Longitudinal Mode, R.H. Smith & N.D. Geddes
- AFWAL-TR-81-3090, Notes on Lateral-Directional Pilot Induced Oscillations, R.H. Smith

HPE

14

Smith-Geddes Criteria:
 Criterion Phase Angle vs Cooper-Harper Rating
 AFFDL-TR-78-154

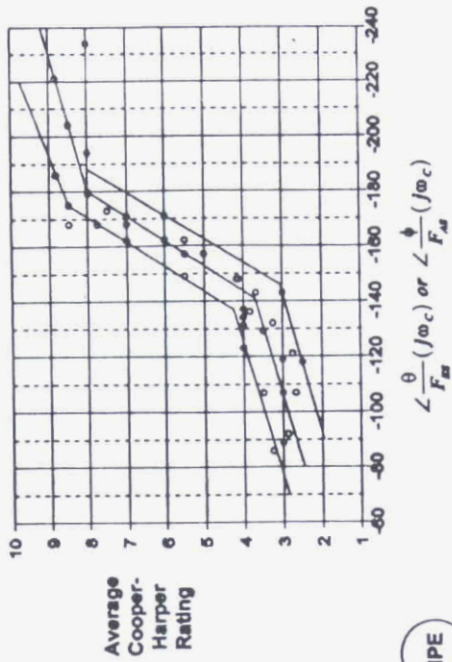

HPE

15

Smith-Geddes Criteria: Example
 Pitch Rate to Stick Force Frequency Response—Flight Test Data

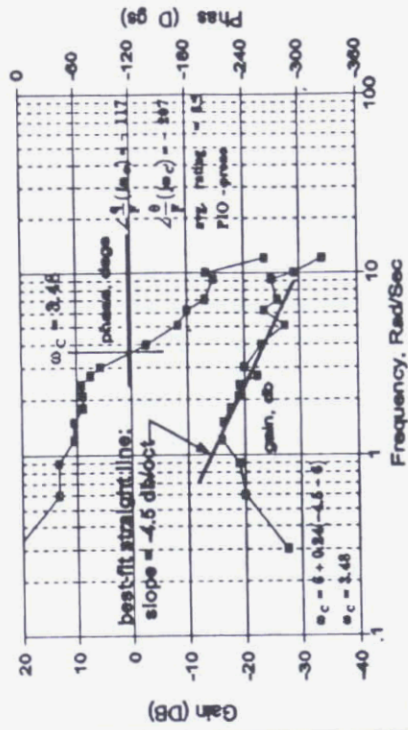

HPE

16

Successful Applications of S-G Criteria

- No known failures of these criteria in PIO prediction or evaluation with actual aircraft
- At least 13 known aircraft, since 1976; approximately 30 different modes and configurations
- Approximately 50 NT-33A configurations
- One dedicated PIO flight test: Bjorkman, USAF Test Pilot School, 1986
- PIO successfully predicted, *prior to occurrence*, in at least 8 cases (Shuttle ALT was the first)
- Successfully predicted Level 1 for all cases with real airplanes for which *valid* handling qualities data are believed to exist

HPE

Rating Scales and PIO

- Cooper-Harper scale is unsuited for identification of PIO susceptibility
 - intermixes task performance & pilot-in-the-loop stability
 - decision tree structure unable to resolve specific parametric effects
- PIOR scale may be acceptable
 - but not in the context of a task-oriented flight test
 - mostly rates closed loop stability
 - still invokes task performance

HPE

PIO Complexity

- PIO isn't that complicated; the basics are really very simple
 - While there are psychological issues that may never be understood, and
 - While the effects of nonlinearities are fascinating and complex,
 - Such considerations are largely irrelevant to the engineering problem of developing criteria and writing design specifications

HPE

PIO Susceptibility and Task-Oriented Flight Tests

- PIO susceptibility cannot be reliably determined from task-oriented handling quality flight tests
 - misleading, unconservative results
 - ok for operational T&E of system performance
 - non-PIO configurations identified from such tests may, in fact, be PIO-prone (necessary conditions for finding PIO not satisfied by test design and implementation)
 - example: LAHOS data

HPE

Position Statement

- Theory is more reliable for diagnosing PIO susceptibility than are pilot evaluations
 - This has been the history of PIO experiences at Edwards AFB since 1976
- Theory has been very useful to the flight test team
 - Confirmation of suspected PIO problem
 - Prediction of PIO frequency has been a confidence builder
 - Guide for evaluation of proposed FCS redesign

HPE

Beyond the Basics: Motivations for Extending the Smith-Geddes Theory

- S-G strictly applies to pre-PIO conditions
- S-G predicts PIO susceptibility, not severity
 - necessary condition for PIO?
- Need extended theory:
 - predict PIO severity
 - incorporate effects of feel system on PIO
 - account for FCS gain effect on PIO

HPE

Inducing Closed Loop Control

- Closed loop, pilot control is required for PIO
 - probability is inversely related to pilot skill
 - test pilot is worst possible candidate for finding PIO
 - doesn't normally "track"
- HQDT
 - forces closed loop pilot control
 - enables PIO identification

HPE

Significance of FBW to Handling Qualities and PIO

- With FBW, aircraft size, type, mission have become irrelevant
 - same FCS design requirements should apply for all aircraft
 - Clinton campaign motto: "it's closed loop control, stupid!"
- Commercial transports, especially those using FBW, should be certified or re-certified to be PIO-free
 - by criteria
 - by HQDT flight tests

HPE

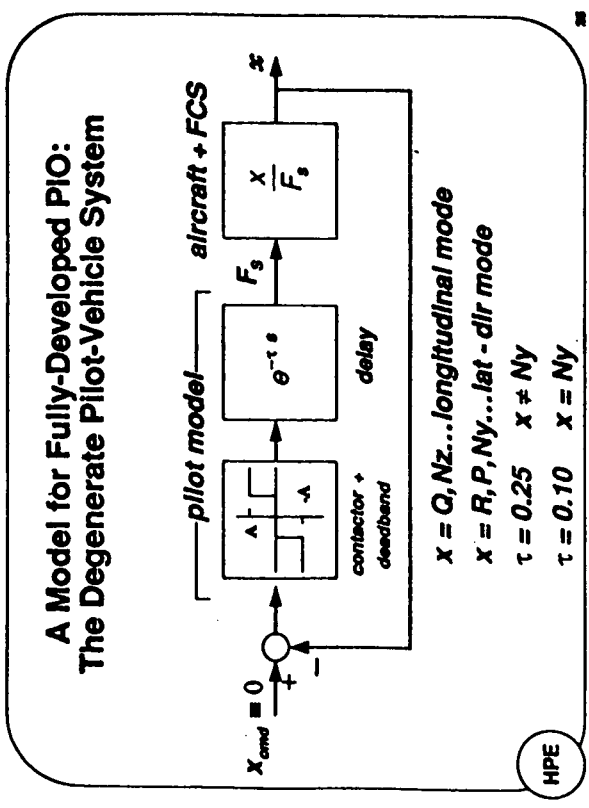

HPE

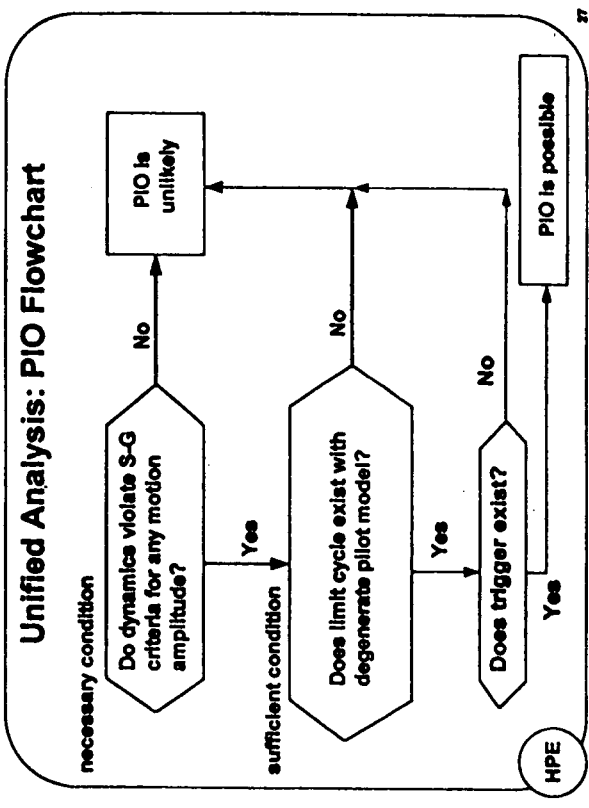

HPE

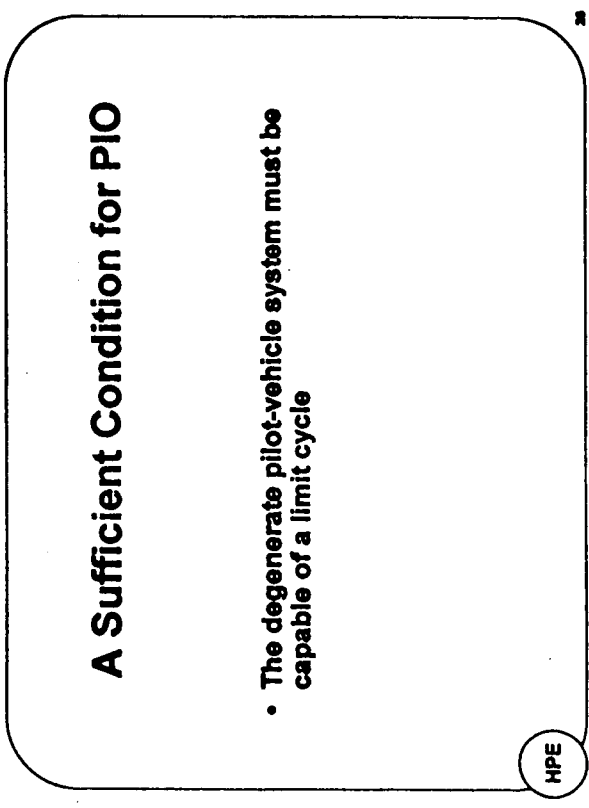

HPE

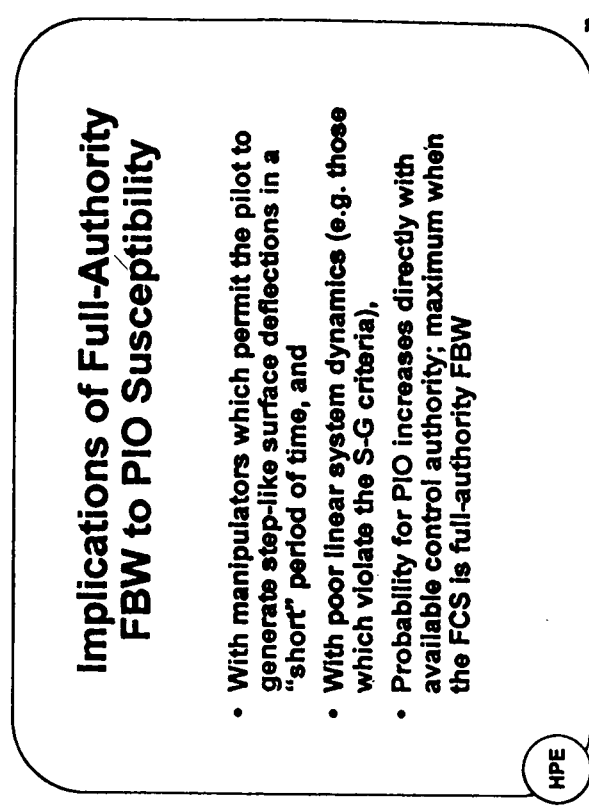

HPE

Manipulator Designs to be Avoided

- Those which permit the pilot to generate large control surface deflections within about one pilot delay period (0.25 seconds, or so), will promote PIO

HPE

22

PIO in "Linear" Airplanes is Possible

- The pilot can provide the nonlinearity
- No rate limiting is required
- No surface deflection limit is required

HPE

21

PIO vs Roll-Ratcheting

- Unified by this theory
- Roll-ratchet is just another form of PIO

HPE

23

The Student Pilot

- Can adapt the degenerate control structure
 - inexperience
 - excitement
- Can create PIO with an aircraft that, in experienced hands, is not PIO susceptible

HPE

22

Implications of Theory: Effect of Stick Force Gradient

- Increasing gradient has similar effect to reducing pilot + airplane system gain in a position-sensitive FCS
- Stick force amplitude is constant in PIO
- Increased gradient implies reduced stick deflection in PIO
- Result is increased gain margin of the pilot-vehicle system, when deflection is the control law input

HPE

Control Authority: Effect of Command Gain vs Stick Gradient (Position Command System)

- Theory appears to have been confirmed by recent flight and simulator tests
- Flight test:
 - Feel system unmodified
 - Command path gains reduced
 - PIO susceptibility reduced (eliminated?)
- Simulation:
 - PIO eliminated with:
 - » increased force gradient at constant gain
 - » decreased gain at constant force gradient

HPE

Stick Force Gradient vs Command Path Gain

- Reducing command gain is similar to increasing stick gradient
- Increasing stick gradient to minimize PIO, without changing command gain, has the advantage of retaining original control authority, but with increased stick force level

HPE

Preferred Pilot-FCS Interface Design

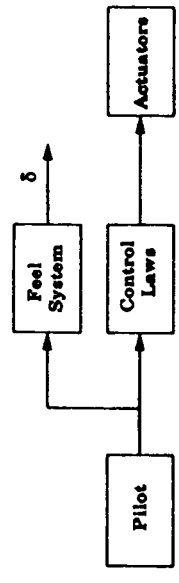

- Minimizes system phase lag at the criterion frequency
1. $\angle \frac{\delta}{F}(\omega_c)$ is eliminated from the system phase $\angle \frac{Q}{F}(\omega_c)$ (typically about 25 degrees)
 2. Cooper-Harper rating is optimized, according to the Smith-Geddes criteria

HPE

Unified Criteria for ACT Aircraft Longitudinal Dynamics

Mr. Roger H. Hoh
Hoh Aeronautics Inc.
Vista Verde Center #217
2075 Palos Verdes Dr. North
Lomita, CA 90717
United States

1) Introduction

Roger Hoh pointed out that the USAF was pursuing the PIO issue actively and was in the process of appointing contractors to research the problem and was encouraging them to share experience and work together to a solution. He went further, by suggesting that the AGARD community could, perhaps, assist in this process, as had occurred in the past with, for example, Working Group 17, which had examined the Handling Qualities issues for highly augmented and unstable aircraft. A key issue within this process was identified as "the encouragement of people to express their ideas openly".

2) Possible Criteria and the Characteristics They Try to Encompass

Essentially, the analysis commences with examination of the small amplitude, short term response of the aircraft as indicated in figures 1. Here, the areas examined are the attitude bandwidth, ω_{BW} , and τ_p , the flight path bandwidth and any dropback. With this established, the analysis moves to the moderate amplitude response, looking at attitude quickness as the critical parameter.

Phase lag at the crossover point is seen to be a key element of any criteria which attempts to evaluate this problem of PIO susceptibility. Examination of the trends for increasing pilot gains allows establishment of the phase margins. Using Mil-STD-1797 as a guideline sets a limit of 45° phase margin under the conditions of maximum pilot tracking gain. If the pilot continues to track with increasing gain, then it becomes essential to examine the phase roll-off. Two examples of differing characteristics are shown in the figure 1. The problem relates to identification of how far you can go before running into the problems.

Figure 2 illustrates the type of boundaries which can be applied to the small amplitude, short term control measures of Phase Delay, Pitch Attitude Bandwidth, dropback and, finally, flight path bandwidth and pitch attitude bandwidth.

Figure 3 illustrates the concept of quickness, which is routinely applied to the rotary wing aircraft, but is not yet used in the fixed wing application. The concept is analogous

to bandwidth, except that it applies to manoeuvres of larger amplitude. The figure illustrates the expected shape of the boundaries and how the terms are defined from the frequency response.

2.1) The Concepts of Phase Delay

Phase delay captures the "shape" of the frequency response curve nicely. For many systems, which feature classical aircraft behaviour typical of aircraft without complex augmentation and actuation systems, it is possible to use the Low Order Equivalent Systems (LOES) approach as for these cases the shape is described via the "time delay". In these cases, PIO will occur when a small increase in gain is accompanied by a large loss of phase. However, for aircraft which do have complex augmentation, then such an approximation is likely to be misleading as the phase roll-off cannot be captured adequately via an equivalent systems approach. For such systems, it becomes essential to examine the phase roll-off in detail. Figure 4 illustrates the differing aircraft response types which may be encountered, with clearly very different characteristics.

In examining the database for the effectiveness of the Various criteria, it became apparent that some cases did not fit well with the recommended criteria for assessing handling qualities and PIO susceptibility. Figures 5 and 6 illustrate some of the effects. However, when the John Gibson dropback criterion was added and applied, then the points mostly came into a sensible fit. As an alternative approach, work at NASA Dryden has utilised the flight path bandwidth, with equal success.

Of interest, it was noted that the Space Shuttle failed all the criteria, whichever way they were looked at. Whilst it is perhaps not surprising that this vehicle does have a PIO tendency, what is surprising is that the pilot evaluations are not to be trusted. The vehicle awaits the appropriate trigger for a major PIO and this should not be a factor in the decision process. The deficiency is there, should be recognised and fixed.

2.2) Triggers

From what had already been presented, it was clear that the concept of a "trigger" mechanism is warranted. However, it is not clear what the actual triggers are. Ralph Smith indicated that the trigger mechanism could actually be within the aircraft, or it could be the pilot, usually responding to some external influence. Both are significant and neither aspect should be ignored in any analysis or assessment. During the discussions which took place during the workshop, it was suggested that it may never be possible to identify all the triggers which are out there waiting for the right set of circumstances.

2.3) The Effects of Rate Limiting

Presently, no criteria are available which relate to the implications of rate limiting for fixed wing aircraft. The use of Attitude Quickness parameters is the closest approach, but this is confined to the helicopter fraternity. Combining the Attitude Quickness with bandwidth at small amplitude does enable the effects of rate limiting to be picked up with the use of aggressive Mission Task Elements.

2.4) Response Characteristics and Appropriate Analysis Techniques

One of the problems which has to be faced is that with Active Control Technology, it is possible to make the response look like anything that you want. However, different mechanisation will influence the response shaping. Again, figure 4 illustrates this effect.

Classical aircraft responses have the form of k/s between the phugoid and short period for the flight path response. The application of Equivalent Systems depends on this characteristic being followed. If the system under investigation does not follow this pattern, as many ACT systems do not, then the Equivalent Systems approach cannot be used reliably. An example of this is with a rate demand, attitude hold system, which does not follow the form of k/s . If the LOES methods are applied to this type of controller, then it is possible to fix the pitch response but degrade the path response.

2.5) Feel System Influence

One concern which was raised in the presentation relates to the question of whether or not to include the feel system in the model for assessment and establishment of the criteria. Ideally, a common approach would be adopted for all criteria, based upon first principles. Currently, it is believed that the choice is made somewhat arbitrarily, depending upon the team's past experience rather than upon any deterministic assessment.

3) Concluding Remarks and Discussion

As far as criteria development is concerned, the presenter agreed with Ralph Smith that all aircraft needed to be evaluated against some criteria. In this regard, the work which had been reported by John Gibson appeared to capture the

response shaping characteristics very nicely. It had been shown that these methods even capture the T-38 PIO.

On this basis, it would appear that there is a combination of criteria required to adequately predict the susceptibility to PIO and that no single criteria could adequately capture the characteristics in a meaningful way.

In the discussion which followed this presentation, the effects of rate limiting were raised. These effects can be sufficient in their own right to bring about a PIO tendency. It was admitted that PIO usually starts out of rate limiting, but the effect of rate limiting is to lock the PIO in. This requires very positive action to unlock, e.g. by either clamping or letting go of the stick. It was noted that this is not always psychologically either possible or desirable!

Rate limiting effects are not covered in any of the flying qualities specifications. The question was asked, "Why not?". To cover this aspect, the criteria needs to cover the effects of amplitude and it is not clear how to incorporate this effect into the criteria. This could imply problems for "Carefree Handling" systems, in that do we really understand what is required to achieve the carefree handling objective when the effects of amplitude on the handling qualities criteria remain to be defined.

Chic Chalk raised a point about the T-38 PIO. Analysis performed by STI had shown that the pilot could not adopt to the change in dynamic characteristics which occurred with the bobweight working and not working. He pointed out that on the T-38 it was possible to move the controls without moving the bobweight due to the effects of the actuation control valve.

Figure 7 summarises some of the characteristics of the T-38 PIO which has been reported by Northrop in report NOR-64-143 and has been subjected to analysis by Systems Technology, Inc. Figure 8 shows the flight record of the PIO itself.

This particular PIO case has been the subject of many separate analyses over a period of time, due to its unusual features. Here it has been analysed using the various available current criteria with varying effect, as illustrated in figures 9 to 12. Use of the Mil-STD-1797A approach, i.e. the equivalent systems CAP criteria is shown in figure 9. This indicates that the effect of removing the bobweight is to reduce the predicted handling rating to Level 3.

Use of the "Gibson" criteria, shown in figure 10, indicates that both with and without the bobweight, the vehicle would be likely to have a PIO, due to low gain margins without the bobweight and because of the bobble and dropback combined with high phase rates with the bobweight.

Figure 11 shows an application of the R. Smith criterion, which indicates there should be no PIO, with or without the bobweight and that the bobweight should improve the aircraft's handling.

Using the bandwidth and overshoot/dropback criteria, the results of figure 12 show that this predicts a PIO with the bobweight and not without it.

From the evidence of these analyses, it could be concluded that there is sufficient evidence that a PIO could be predicted, as could the effects of the bobweight on this particular aircraft. However, during the discussions, it became apparent that the impact of the actuation behaviour may have had a dominant effect on the overall behaviour of the aircraft, and that separating out the effects of the actuation and bobweight may not be as straight forward as at first thought.

ANATOMY OF A PILOT INDUCED OSCILLATION - EFFECT OF τ_p

(DATA FROM NEAL-SMITH T-33 FLIGHT TESTING)

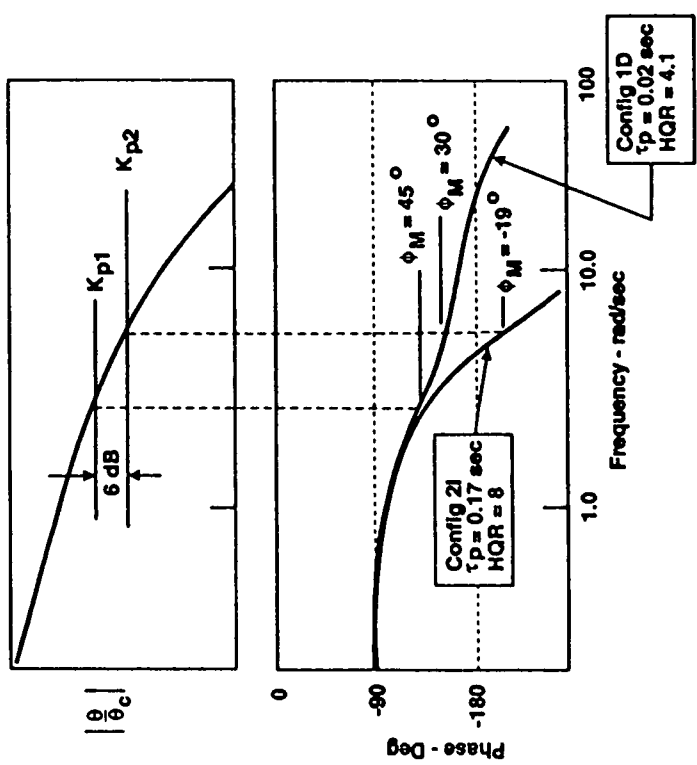

UNIFIED CRITERION FOR SMALL-AMPLITUDE, SHORT-TERM CONTROL

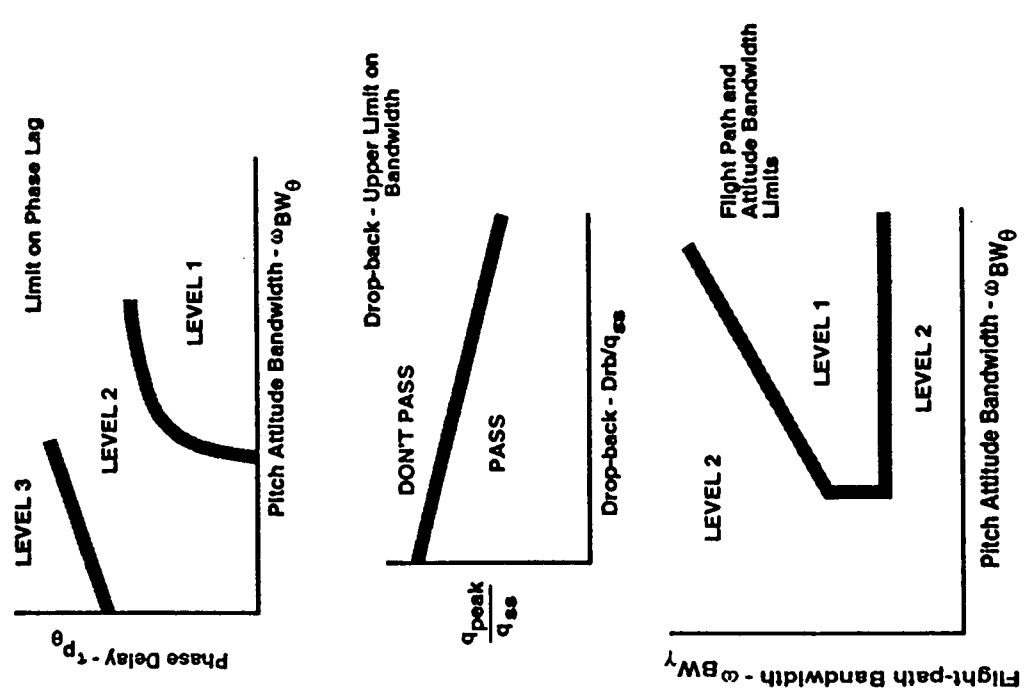

**ATTITUDE QUICKNESS CRITERION AS A MODERATE AMPLITUDE
 AGILITY REQUIREMENT**

BASED ON OPEN LOOP BOXCAR INPUTS OF VARYING DURATION AND
 AMPLITUDE.

IS ANALOGOUS TO BANDWIDTH, EXCEPT IT APPLIES TO LARGER
 AMPLITUDE MANEUVERS.

DEFINITION OF CRITERION PARAMETERS, AND EXPECTED SHAPE OF
 BOUNDARIES IS SHOWN BELOW.

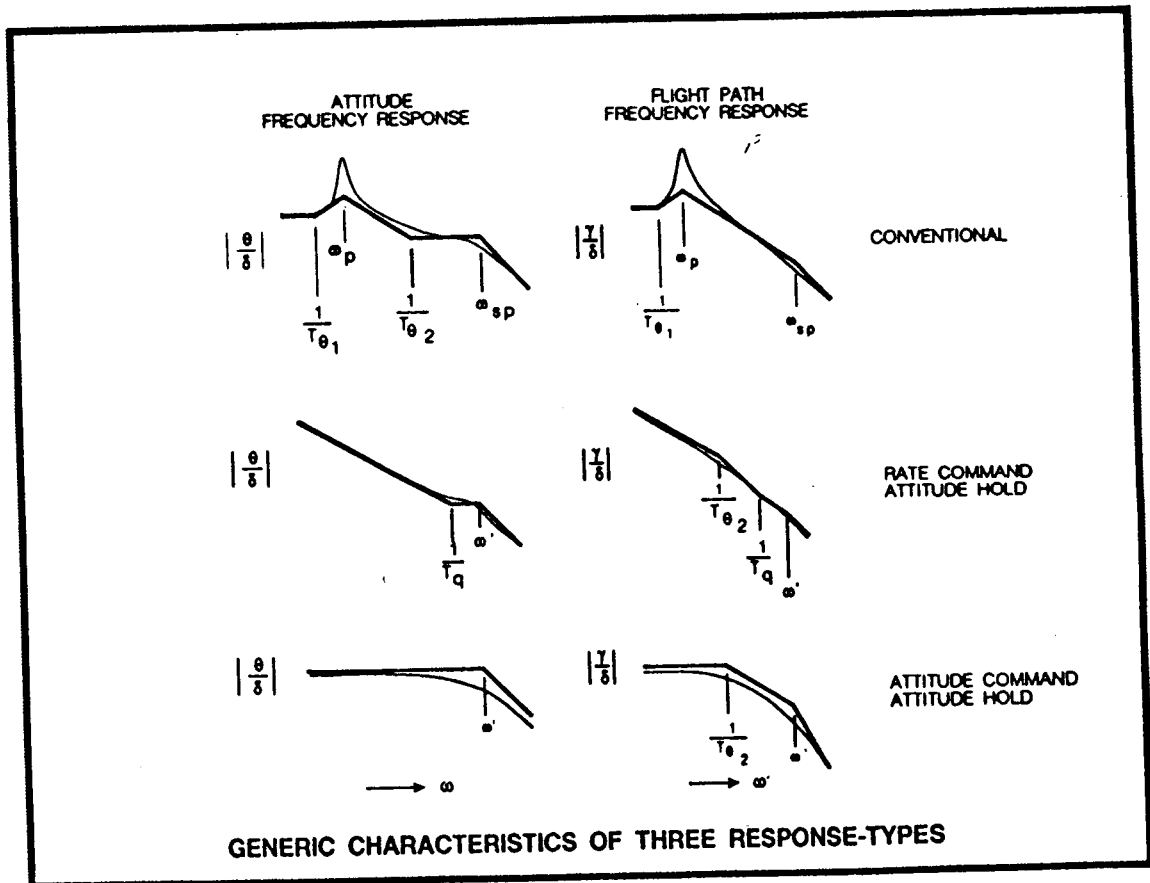
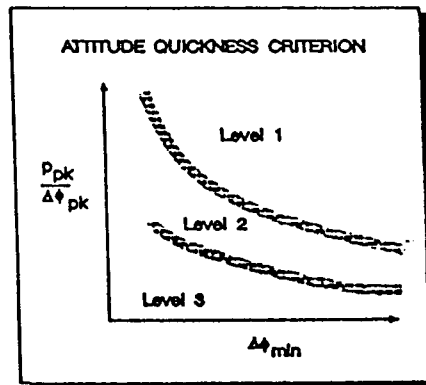
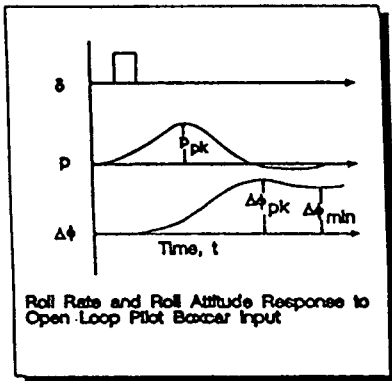

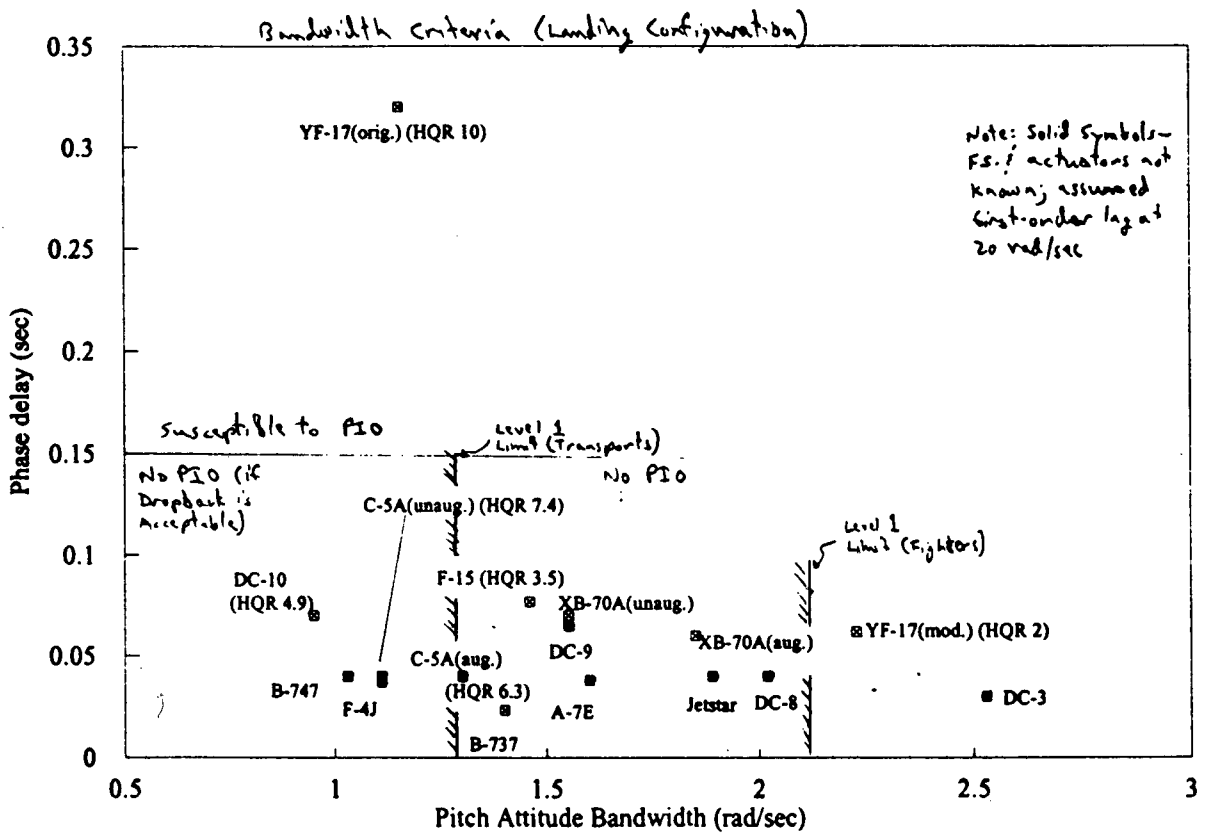
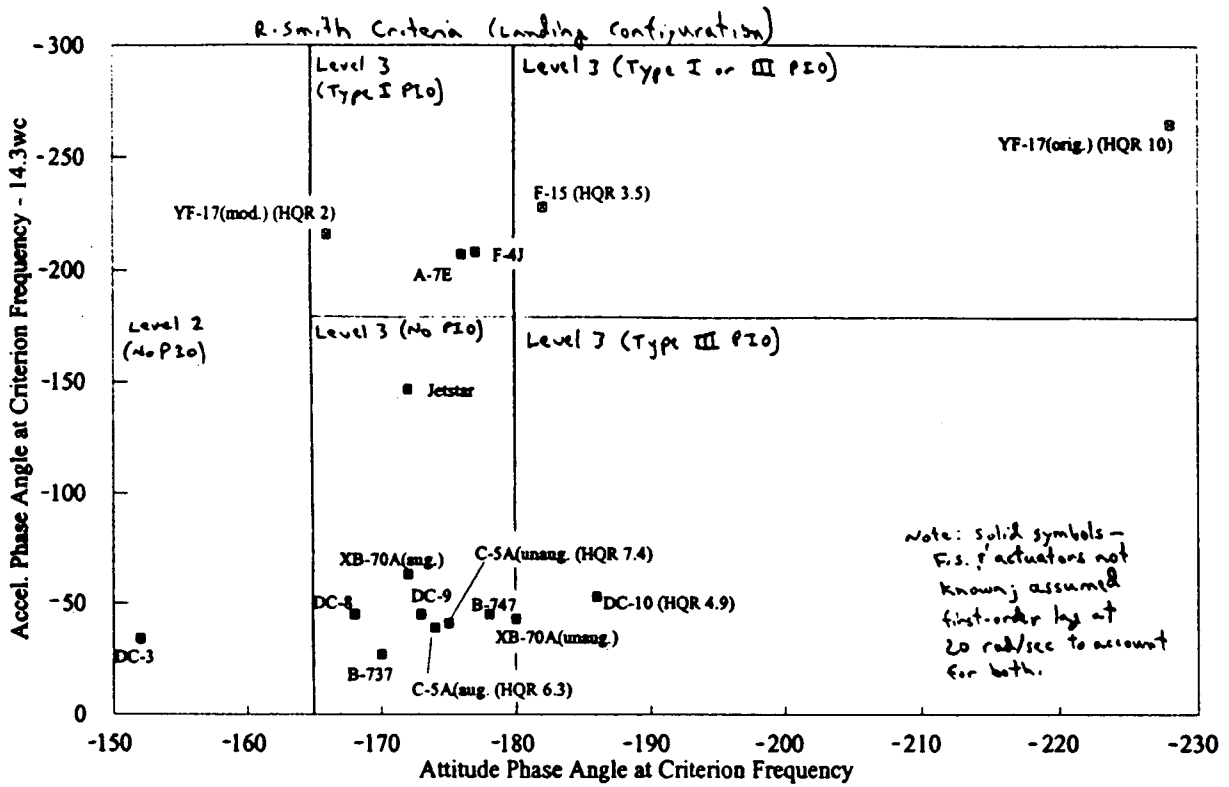

EXAMPLE APPLICATION OF PIO CRITERIA

- T-38A PIO: $M = 0.91$, $h = 6500$ ft
- Nonlinear bobweight effects
- Reached load factors of about $+8g$, $-9g$
- No bobweight:

$$\frac{\theta}{F_c} \approx \frac{M_{F_c}(s+3.18)}{s(s+20)[s^2+2(.4)(7)s+7^2][s^2+2(.18)(18)s+18^2]}$$

- Bobweight loop closed:

$$\frac{\theta}{F_c} \approx \frac{M_{F_c}(s+3.18)}{s(s+21.8)[s^2+2(.1)(9.8)s+9.8^2][s^2+2(.23)(17.7)s+17.7^2]}$$

TIME HISTORY OF THE PIO

- Analyzed by Systems Technology, Inc.
- Results published in Northrop Report NOR-64-143

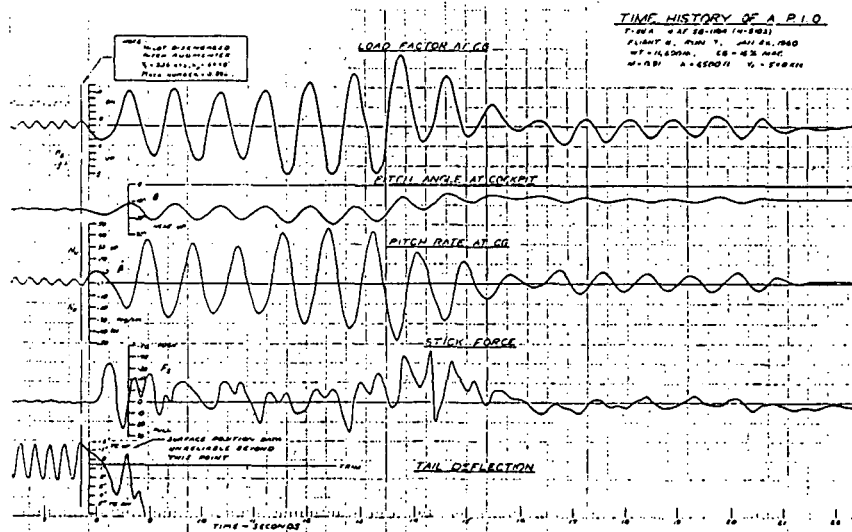

APPLICATION OF MIL-STD-1797A CRITERIA

- Equivalent Systems (CAP) criteria: handling qualities Levels

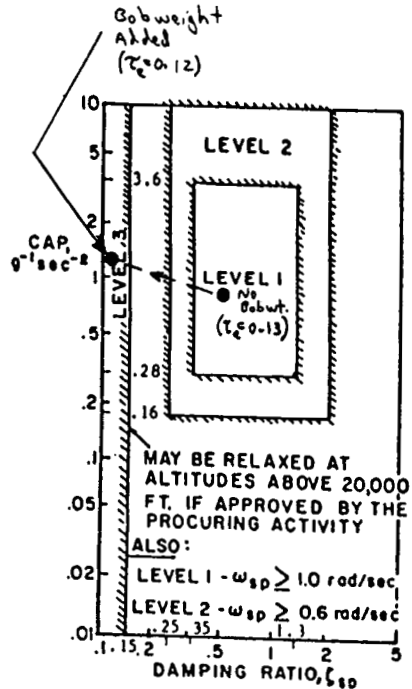

- No bobweight: Level 2
 - High time delay
- With bobweight: Level 3+
 - Level 2 time delay
 - Below Level 3 damping

APPLICATION OF MIL-STD-1797A CRITERIA

- Gibson design criteria (no handling qualities Levels)

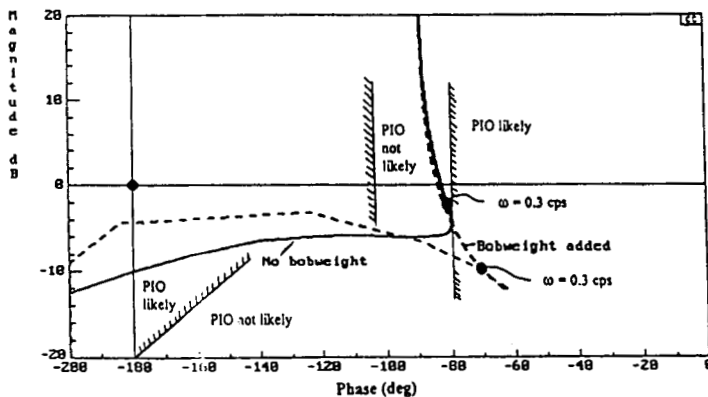

- No bobweight: PIO likely
 - Low gain at 0.3 cps
 - High phase rate
- With bobweight: PIO likely
 - Bobble and dropback
 - High phase rate

APPLICATION OF PROPOSED CRITERIA

- R. Smith (including Level boundaries for comparison purposes)

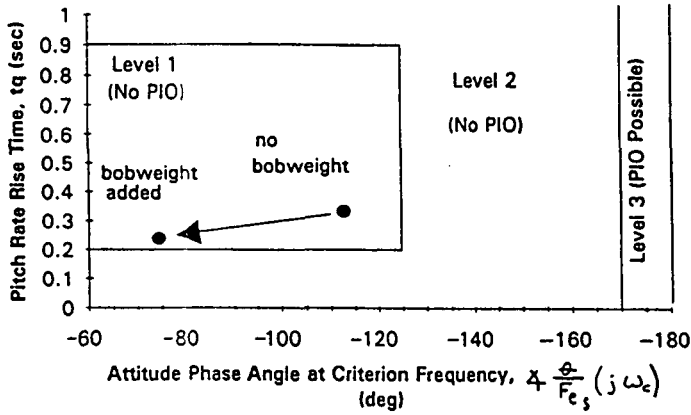

- No bobweight: No PIO
 - Solid Level 1
 - Meets stringent limits
- With bobweight: No PIO
 - Solid Level 1
 - Improved handling

APPLICATION OF NEW CRITERIA

- Bandwidth plus overshoot/dropback (including Levels)

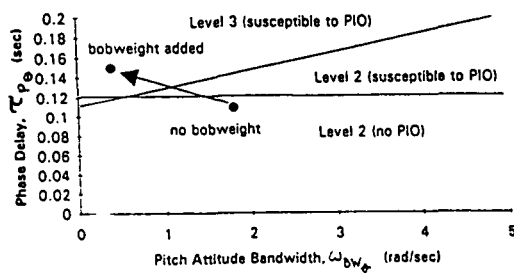

- No bobweight: No PIO
 - Level 2 (low Bandwidth) (gain margin limited)
 - No pitch bobble
- With bobweight: PIO likely
 - Level 3+
 - Pitch bobble

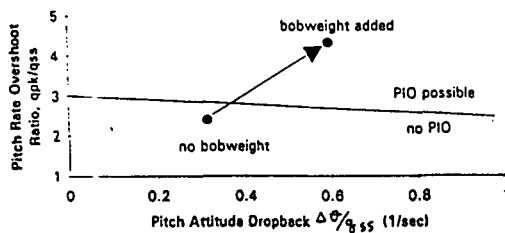

Looking for the simple PIO model

Mr. John C. Gibson
Consultant
19, Victoria Road
St Annes, Lancashire
England
FY8 1LE
United Kingdom

1) PIO Characteristics

The PIO record of the NASA F-8 DFBW in Figure 1 is an amalgam of many general features to be found in such events. There is a tight task, to keep the nosewheel off the ground despite limited rear fuselage clearance; excessive lag from the 0.1 second time delay; an initially small rapidly diverging attitude oscillation; the onset of actuator rate saturation leading to a marked reduction in frequency, accompanied by a tail strike to spur on the pilot's efforts; some full amplitude stick inputs; removal of the time delay but with no immediate effect; selection of SAS "on" changing the dynamics sufficiently to produce a subsiding oscillation; a corresponding increase in frequency; and eventual recovery. The pilot's inputs track the frequency with varying form, from effectively an initial sinusoid in anti-phase with the attitude, to an irregularly non-linear form where the phasing of the fundamental wanders about in between the pitch rate and the attitude peaks.

Among such generality, the fine detail varies from case to case. In the Figure 2 PIO (which initiated the PIO criteria developments over many years at BAe Warton), the landing task was routine and the pilot perceived the event as some initial turbulence response followed by a large pitch up despite full forward stick. Although to an engineer this was plainly a PIO, the pilot was completely unaware that an oscillation driven by his inputs had occurred. The input sinusoid fundamental diverges from a small beginning and tracks the attitude very closely, the frequency reducing as rate saturation sets in. There is an additional higher frequency dither which may be neuromuscular, possibly associated with the natural frequency of the pitch control circuit.

In the Figure 3 event, with an intermediate FCS standard, the reverse situation applied. It could be identified only because the pilot said he had frozen the stick just before touchdown as he felt he was entering a PIO. The record shows a reduction in amplitude, an increase in frequency from the final approach stick pumping, and an increase in stick dither. These are insufficient to indicate a PIO by analysis, the previous pumping being of entirely normal character induced subconsciously. However, it confirmed a prediction made by the author that this FCS standard would be found unsatisfactory, and it led directly to prohibition of its use for take off and landings until the final standard was introduced.

In the phase between initial and intermediate FCS standards, a Panavia company conducting Tornado performance take off trials performed an acceleration with the initial augmentation standard engaged in order to reduce the stick load to achieve

full leading edge down tail angle, Figure 4. The intent was to switch off the augmentation as the aircraft rotated for lift off, but the deep saturation due to excessive command gain allowed a sharp pitch up before the tail moved off its stops. The resulting corrections launched the pilot into an instant fully developed large amplitude PIO, which subsided at once after the augmentation was eventually switched off. Dominated by the actuation characteristics, the PIO remained virtually constant over a speed increase greater than 100 knots. In this example there was no divergence from a small beginning; the pilot's inputs were irregular and non-linear; and the fundamental phasing lies somewhere between the pitch rate and attitude peaks.

The YF-22 PIO, Figure 5, did not occur during take off or landing but in a low altitude fly-by. Set off by an unexpected trim change, the PIO diverged rapidly from small to large amplitude. The rate limiting said to be a factor is not obviously evident in the stabilator or nozzle records. Presumably it was located within the control law functions in such a way as to add substantial phase lag, explaining the failure of the relatively smooth stabilator trace to reflect the sharp corners of the stick input trace. At first the pilot's inputs were non-linear and slightly irregular, with the phasing drifting from the attitude towards the rate peaks, but then entered a period of gross irregularity.

The oscillation in Figure 6, from the FBW Jaguar digital FCS research aircraft, shows how powerful is the attraction to the "PIO frequency" (nominally where the attitude lags the stick by 180°) even for the most minute amplitudes. The flight was in cloud, and a pitch mode change selected by the pilot resulted in a change of trim stick position faded over a few seconds. At the same instant the HUD failed, leaving the pilot with only the head down attitude indicator. He immediately entered what he described as a $\pm 1/2^\circ$ attitude PIO, but as the traces show it was much smaller than that, approximately $\pm 0.06^\circ$ with a stick amplitude of ± 2 mm or less. There was about the same pitch acceleration as is normally excited in the landing flare pitch pumping, due to the high PIO frequency of 1.8 Hz which also agreed precisely with the analytical value. Apparently this enabled the pilot to maintain a low input, but he misinterpreted its double integration into an assumed attitude oscillation which was not otherwise visible to him. The high pitch rate sensitivity (see Reference 1) of the design led to excessive gain at the PIO frequency, but all other PIO indicators were negligible. In this example the pilot's inputs were essentially linear and in anti-phase with the attitude - or more probably in phase with the pitch acceleration which was the only physical cue available.

Figure 7 is included as a reminder that roll PIO can be just as much a problem. In this case the cause was a mixture of spoiler actuator rate saturation and excess command gain and phase lag at the PIO frequency, and it was eliminated by attention to the latter. Nowadays one would certainly consider the new rate limit algorithms called for by A'Harrah as well. A result of the saturation is that both spoilers operate simultaneously for periods, in which the control power is effectively doubled. Here the pilot inputs again contain a range of phasing and non-linearity. (Similar actuation effects may be the cause of reported occasional roll PIO on some modern jet airliners, and it is known that a command filter has been provided to cure this on one such FBW type.)

2) The Pilot

It is one thing to determine what the pilot did in each of these PIO examples, but quite another to develop a theoretical pilot model which could predict before the event the exact behaviour seen there. The non-linearity and irregularity makes success unlikely in the extreme. One reason for seeking the simplest possible pilot model for PIO is evident in the film of the Figure 1 PIO. The extreme variations in attitude so close to the ground would be stupefying. It is typical that pilots in such PIO believe that something has failed and their reaction is little more than a desperate survival effort to prevent the aircraft from impacting the ground - the "lawn dart trick" of the YF-22 pilot. The lack of connection felt by the pilot between the stick and the response has been discussed further in Reference 1. These factors are ample explanation for the "out of body experience" described by a speaker at the Workshop. A subtle control strategy could not be expected. It is also unnecessary to invoke the control of normal acceleration in landing or take-off pitch PIO, and meaningless in roll PIO which is of generally identical character.

In the pursuit of understanding normal closed loop pilot behaviour and of optimum handling qualities through the FCS design process, the simplest functional pilot-aircraft model, K/S, has been of inestimable value even though it does not represent reality perfectly and despite the existence of highly detailed structural models of the human pilot. In the world of chaos theory - and a major PIO is certainly chaotic! - simple though non-linear deterministic equations have been shown to provide accurate global representations of random or chaotic behaviour in innumerable fields of science. Examination of PIO records shows the dominant role of the zero crossings of the attitude rate, representing the peaks in attitude but more precisely delineated both in the records and in the pilot's visual perception. This point signals the reversal of the stick motion and enables a simple model of the pilot behaviour to be constructed which gives a sufficiently good global representation of the flight events, even though it will not be exact.

Such a model is implicit in the fixed base simulation PIO assessment techniques used for many years at BAe Warton. Simply by exciting the PIO frequency oscillation at all stick amplitudes including the largest possible, without regard for any task "trigger", it is possible to determine the susceptibility to PIO. The nature of the stick force and displacement characteristics (which must of course be

accurately simulated) tends to induce the variations in shape and phasing seen in the examples above. A conventional pitch stick will tend to produce a sinusoidal input with its peaks locked to the attitude peaks. Shorter travel and/or lighter forces will tend to produce a more relay-like action, but probably retaining some elements of the sinusoid. This would typify a normal roll stick but can be seen in the NASA F-8 record. A very short travel stick is likely to produce an almost pure relay-like action, as in the YF-22, with its fundamental apparently locked to the rate peaks. (See Figure 14 in Reference 1.)

Although non-linear analytical models of such behaviour have not been employed at Warton, the simulator being the preferred option, such models should be perfectly feasible. Two have in fact been proposed at this Workshop, by Chalk and R.H.Smith, and it is strongly recommended that such models should be more widely considered. Some development to include the quasi-sinusoidal inputs would be desirable, since these occur about as often as the more relay-like type.

3) The Aircraft

Despite the need to ensure that PIO can be detected by such methods, it should be mandatory to try to ensure its elimination in the design process itself. It is not too simplistic to assert that PIO happens because it is possible, and that it will not occur where it is not. It is not a mysterious oscillation conjured up by mischance or pilot incompetence. It is a well defined manifestation of a closed loop instability where the necessary aircraft contribution is readily identified. Three of the major aircraft properties relevant to PIO susceptibility, its phase delay, PIO frequency and PIO gain, have been discussed in Reference 1. The gain has not been much considered in the past literature, and is further addressed in the following.

The evolution of the Tornado FCS design to solve the early PIO problem took place over a short period of time commencing more than 18 years ago, pre-dating such material as the LAHOS data and the comprehensive methodology developed at Warton through subsequent projects. It is instructive to compare its PIO parameters with the current criteria, Figure 8. The intermediate design was not a response to the PIO, having been prepared before it occurred, but as it was an obvious improvement it was adopted. The author's reservation noted above was based on there being little change in the pitch dynamics, suspected as being a primary factor but without a positive means of quantifying the effects at that time. The main change was a significant gain reduction at the PIO frequency. This is indeed confirmed by the current criteria, there being little difference in phase delay or frequency but an improvement in gain of one HQ level. The Figure 3 event finally led to the agreement that further improvement was mandatory, which was provided by the final design. The main deficiency of the unaugmented aircraft was sluggishness but with no PIO tendency, and it had in fact always been considered slightly easier to land in this mode than in the initial augmented mode!

The significance of the PIO gain in its own right was seen in a Calspan experiment discussed in Reference 2, where a

configuration was rated 8 and 9 for tracking at 6.9 lb/g. When the stick force per g was increased to 11 lb/g, it was rated 4 for flight refuelling. A somewhat similar experiment was done in a brief BAe familiarisation exercise with the Calspan Learjet 25B. This was designed to explore the effect of the PIO gain in configurations with acceptable phase delay and satisfactory PIO frequency, Figure 9. The handling of cases 1, 2 and 3 was rated essentially levels 1, 2 and 3 respectively, which was the hoped for result. At 6 lb/g, case 3 exhibited a small and continuous oscillatory tracking behaviour, though safety of flight and gross loss of control were not remotely an issue. At 12 lb/g, without a change in dynamics, it became relatively smooth and was rated Level 2 for tracking. The obvious mis-match between the stick force per g and the attitude sensitivity was noted by the pilot.

High order roll PIO is identical in principle to pitch PIO. Because the stick forces are usually light, PIO gain limits based on response amplitude per force input are unlikely to work. The maximum PIO attitude response that can be generated by using full stick displacements have to be specified instead, as noted in Reference 1.

While stating which parameters are useful PIO identifiers, it can be equally desirable to point out those that are not. In the LAHOS and other Calspan flight research data, the "equivalent model" that exactly represented each set of dynamics was of course the basic short period mode plus the lag filter, rather than another nominal mode plus a time delay which looks less and less like a lag the larger its values become and the more deeply one examines all the relevant response characteristics. It is very clear that the PIO susceptibility cannot be identified from the lag value itself but only from the whole integrated response. Figure 10 shows examples where the effect of added lags varied from excellent to no change in rating to catastrophic, without any obvious correlation to their value. The effect is subsumed in the combined effects of the phase delay or average phase rate (Reference 1), PIO frequency and gain.

Figure 11 shows how easily the PIO frequency can be obtained by pencil and ruler from the Bode plots of the Shuttle Orbiter at three PIO flight conditions. The phase delay takes only a little longer. The stick characteristics are not given in detail and so the PIO gain factor is not well clarified, though it does appear to be large. The method is much simpler and at least as accurate as the more elaborate analyses reported in the source, and is a well proven design process.

Another example of the need to examine the actual response rather than some mode parameter or formulaic expression is shown in Figure 12. This violates the nominal linear PIO boundary of $2\zeta_{sp}\omega_{sp} \geq 1/T\theta_2$, which was postulated in considerable discussion about the results as the true explanation for the PIO at low stick forces. In fact even at 1 lb/g the attitude margins are quite substantial because the phase shift associated with the violation occurs at a high enough frequency to cause no serious harm. As shown in Reference 1, if the short period frequency is very low then this violation does indeed create problems. In this example it seems much more probable that the PIO was in flight path

and not attitude at all. In the simulation experiment, height and height rate were the principal parameters displayed to the pilot, the attitude being available only on a head down attitude ball. Flight path angle, equivalent to vertical velocity, always lags the stick by 180° at the short period frequency, while vertical path or height displacement lags by 180° or more at all frequencies. These are notoriously difficult to track in a closed loop manner, and the flight path angle margins here are very small. The truth of the matter could now be resolved only by examining the simulation records - if they are still available after 30 years!

The most difficult aircraft response characteristic to deal with in the prevention of PIO is often the rate limiting, inevitably part of most systems. Its effects depend greatly on its location, but it almost always has at least an unsatisfactory influence on the PIO frequency and gain at large stick amplitudes and at worst may cause catastrophic closed loop instability, pilot-coupled or not. The minimisation of high frequency command gain and phase lag can do much to ameliorate it. It may be that this beast has finally been tamed by the development of rate limit algorithms to eliminate their phase lag, which were called for by A'Harrah. If these are positively confirmed to have no adverse handling effects, as preliminary studies appear to show, then a major cause of non-linear response PIO will have been eliminated.

4) Criteria Formalisation

18 years after the Tornado PIO was successfully resolved, it seems inexplicable that similar PIO problems can still occur. For whatever reason, current formal methods are not working. The Vista F-16 is a powerful tool which should be put to use in establishing a universally acceptable set of criteria for the prevention of PIO by design. It should do this by determining the PIO qualities of a sufficiently wide range of linear and non-linear dynamic qualities, both in pitch and in roll, to establish a customer-defined set of Level boundary limits on whatever parameters are found best to quantify PIO. Only by doing this will it be possible to resolve the claims of the many competing criteria and guarantee a PIO-free future for all. It is not particularly difficult to identify the means.

References:

- 1 Gibson, John C., "The prevention of PIO by design", AGARD FMP Symposium on Active Control Technology, Turin, 9 - 12 May 1994
- 2 Gibson, John C., "The development of alternate criteria for FBW handling qualities", AGARD CP-508, 1991

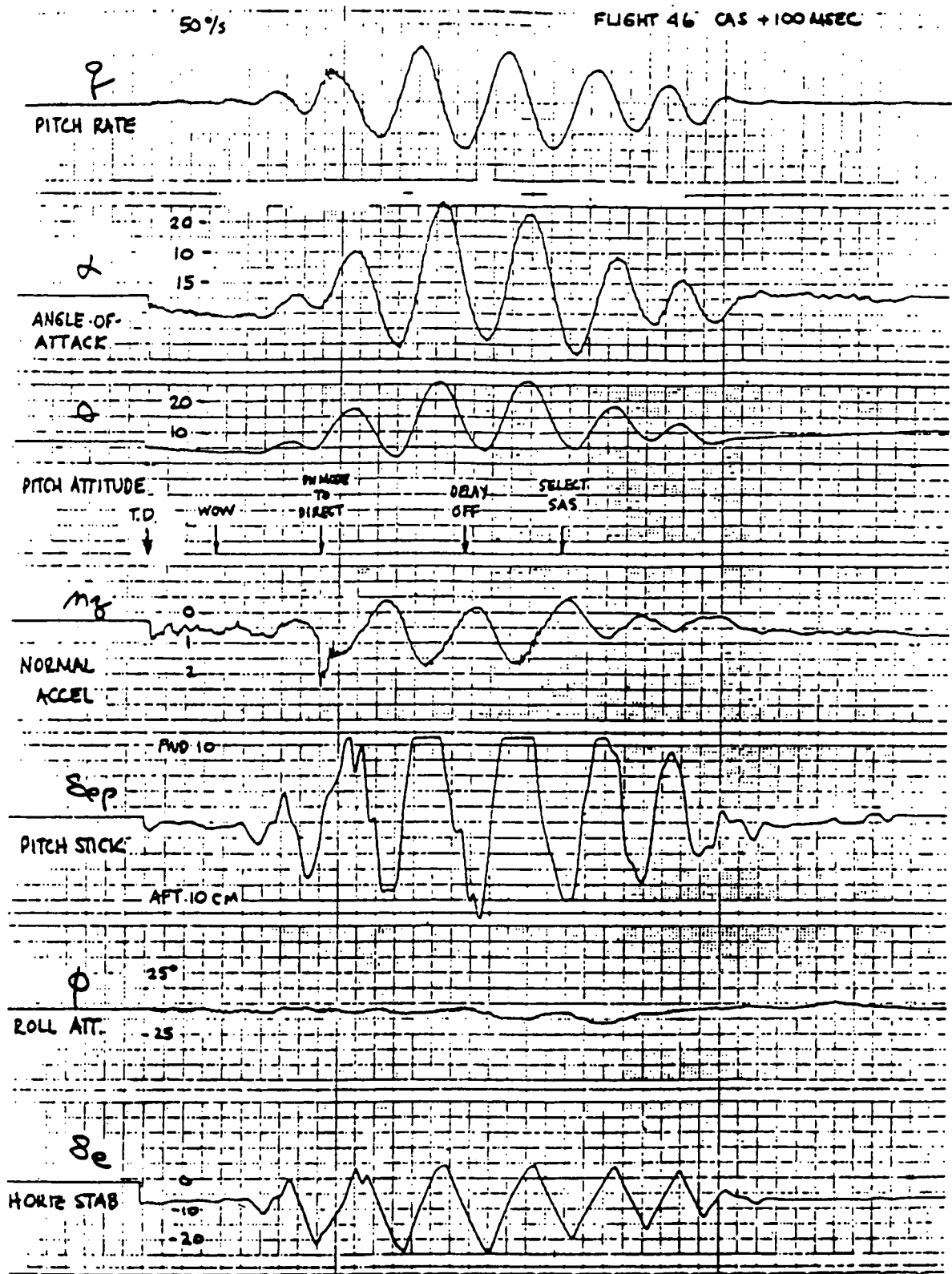

Figure 1 NASA F-8 DFBW go-around PIO

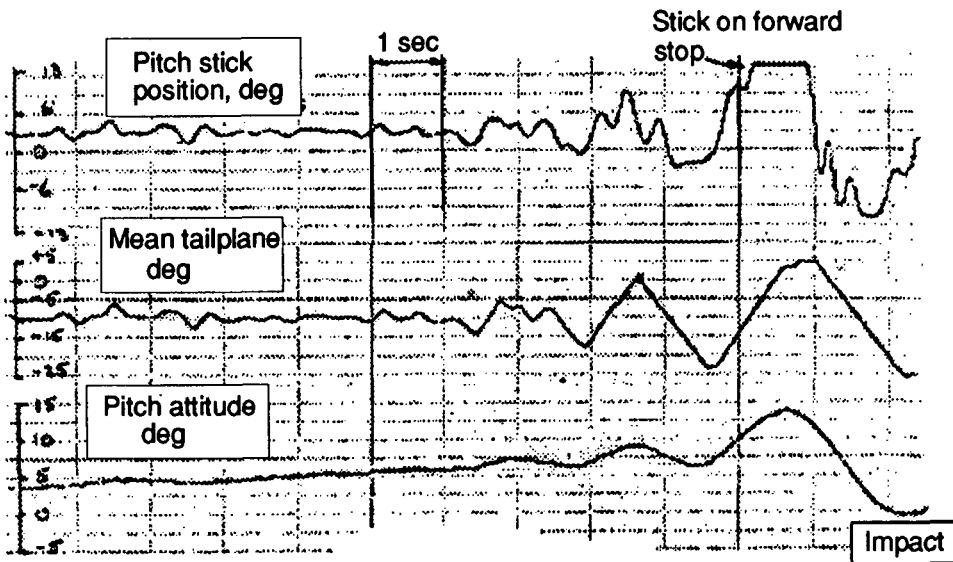

Figure 2 Landing PIO
(Tornado, initial FCS)

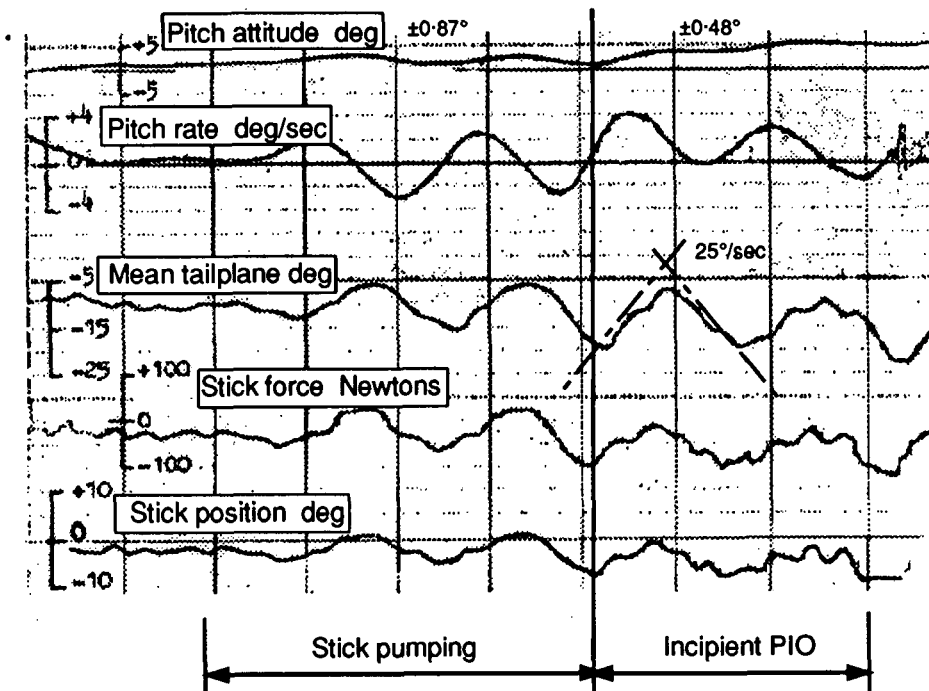

Figure 3 Incipient landing PIO
(Tornado, intermediate FCS)

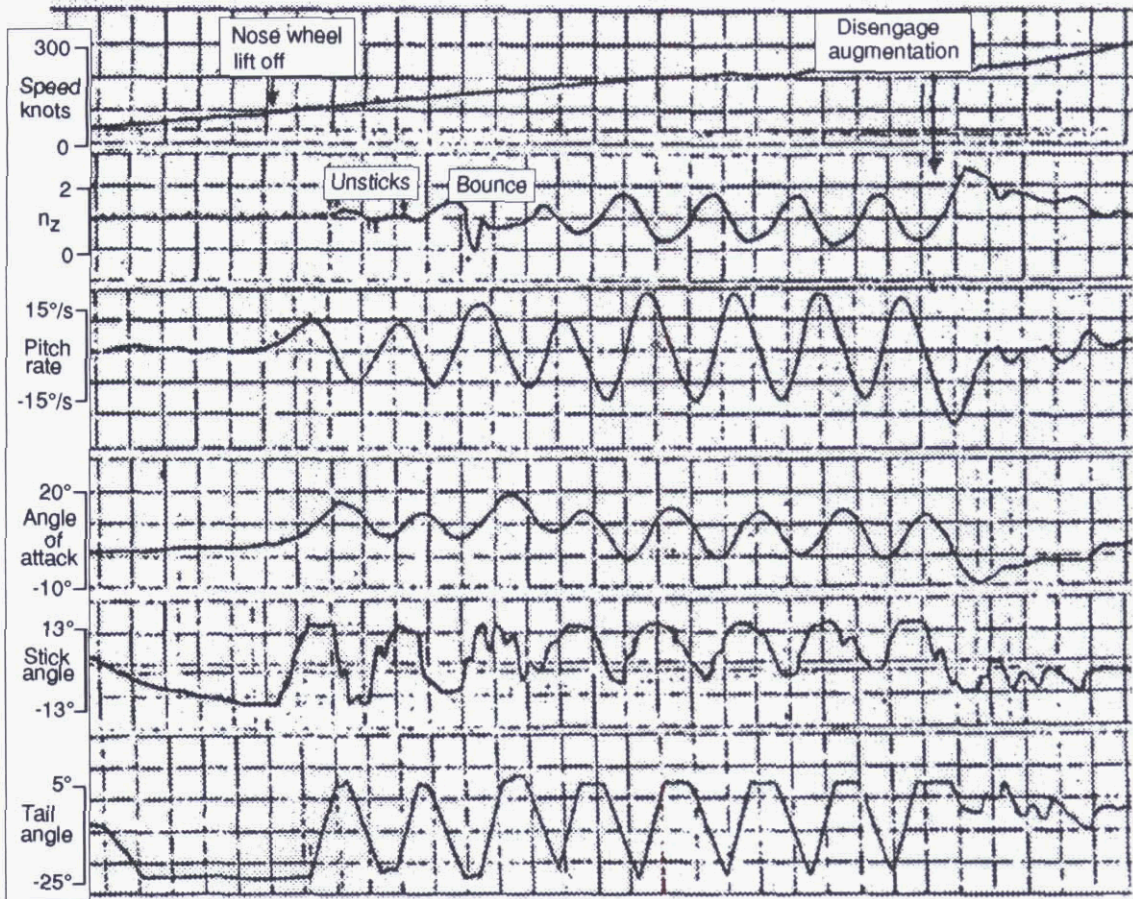

Figure 4 Tornado short take-off PIO

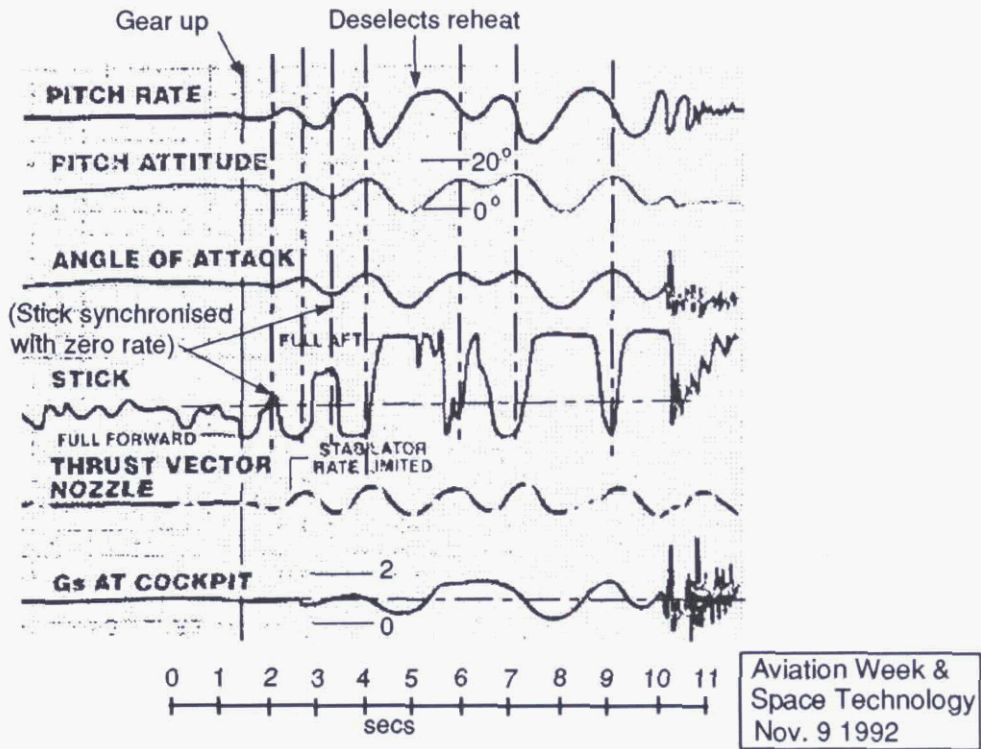

Figure 5 YF-22 landing PIO

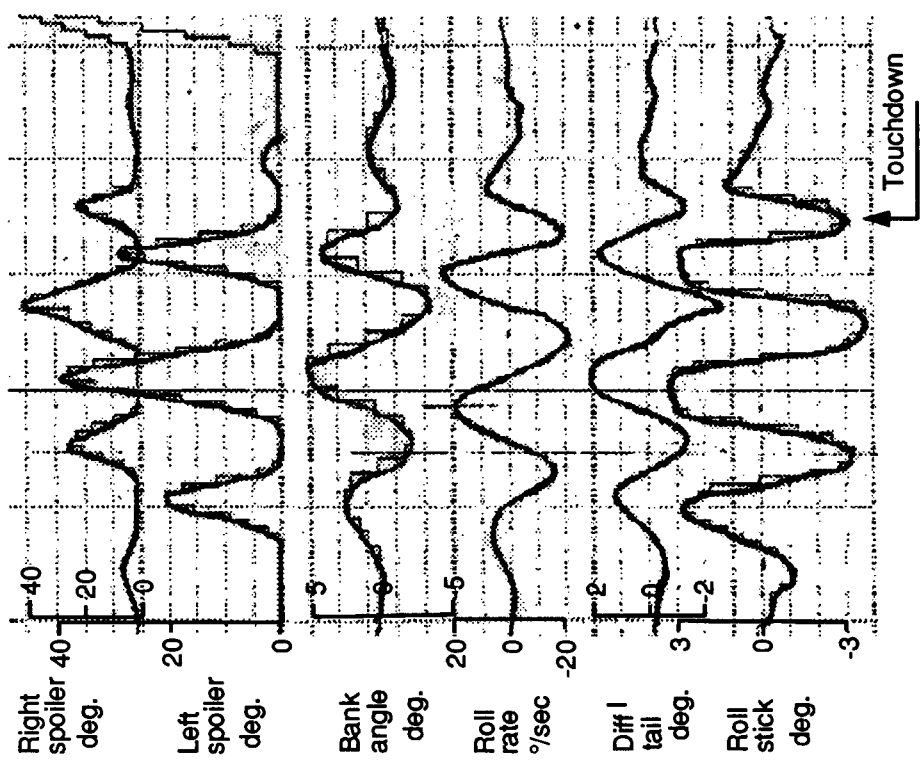

Figure 7 Early Tornado landing roll PIO

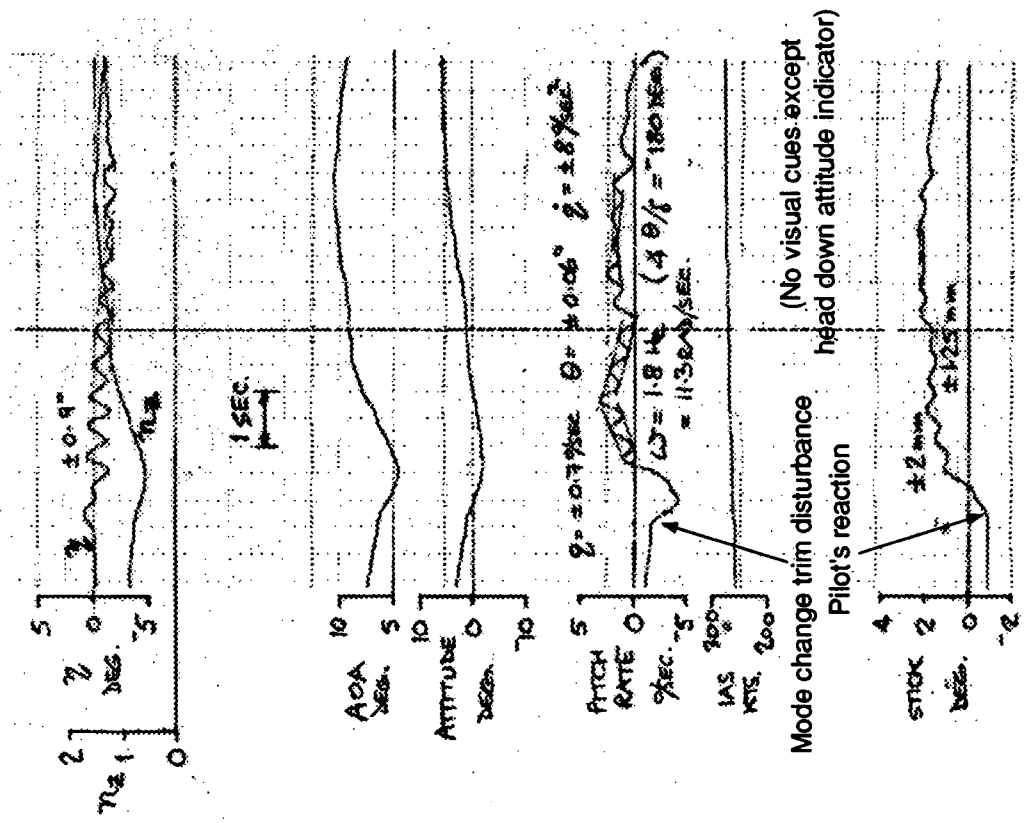

Figure 6 "Pseudo-PIO" in FBW Jaguar

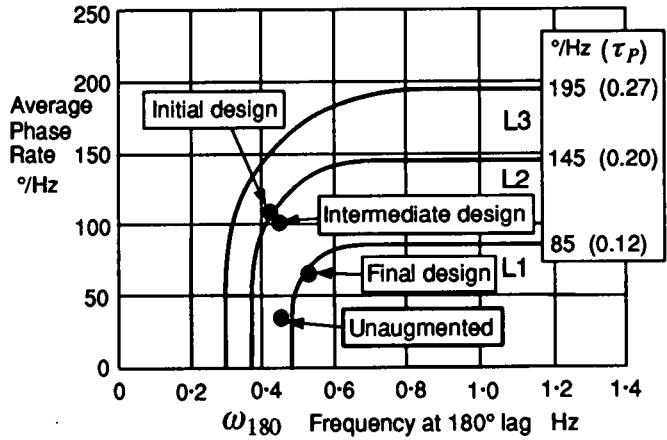
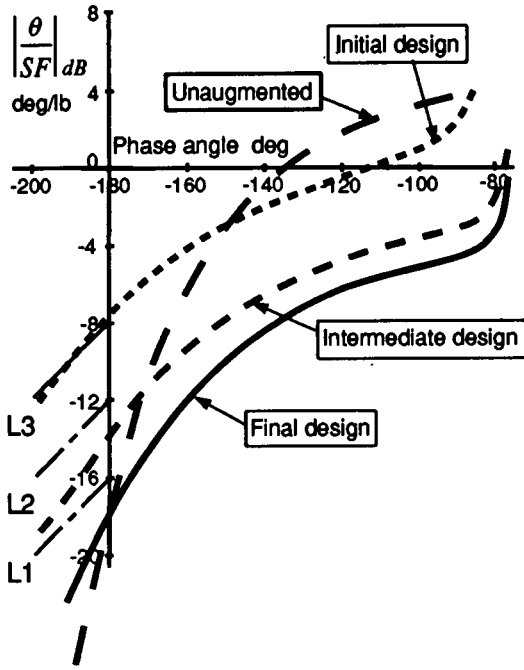

Figure 8 Tornado in retrospect - Cat.C handling

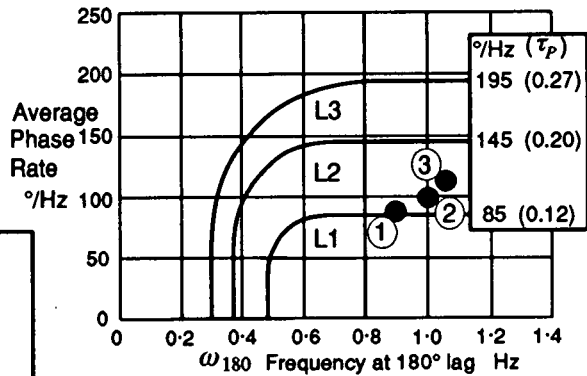
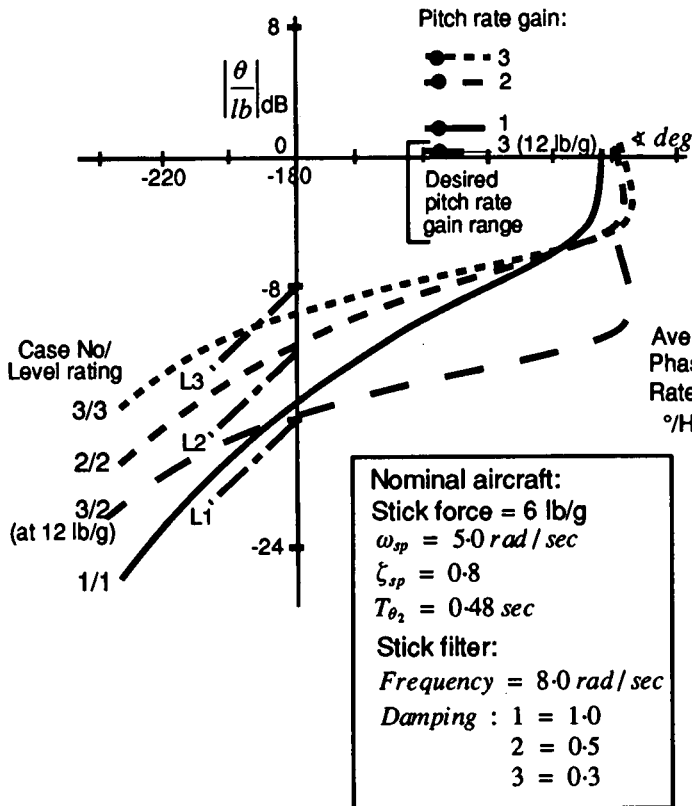
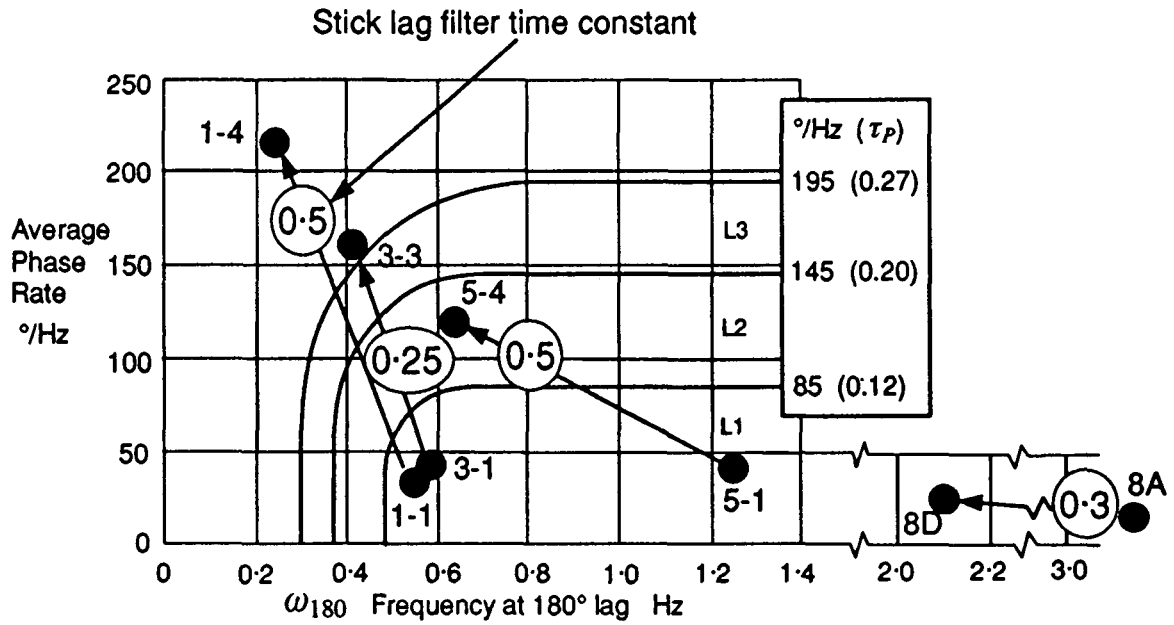
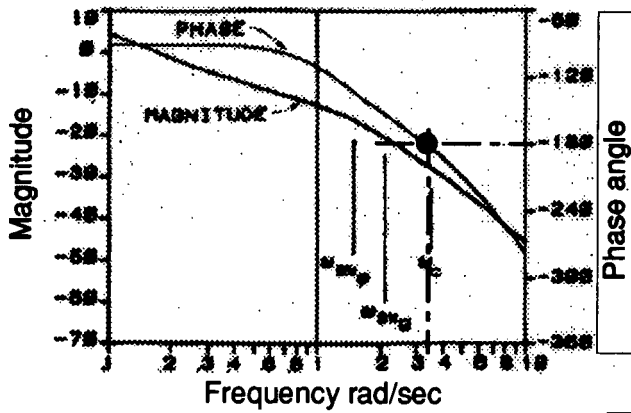

Figure 9 Calspan Learjet PIO phase and gain experiment



Case No.	Lag constant	PIO gain	Rating
1-1	0	Level 1	4 (sluggish response)
+ lag = 1-4	0.5 sec	» Level 3	10 (severe PIO)
3-1	0	Level 1	4, 5 (oscillatory, low damping)
+ lag = 3-3	0.25 sec	> Level 3	10 (severe PIO)
5-1	0	Level 1	5, 7 (oversensitive, abrupt)
+ lag = 5-4	0.5	Level 2	6 (smoother but PIO tendency)
8A	0	Level 1	6 (grossly excessive bobble)
+ lag = 8D	0.3	« Level 1	2 (excellent attitude control)

Figure 10 Non-correlation of added lag and PIO margins



A) ALT Landing PIO
 Actual PIO frequency = 0.57 Hz
 -180° phase frequency = 0.55 Hz

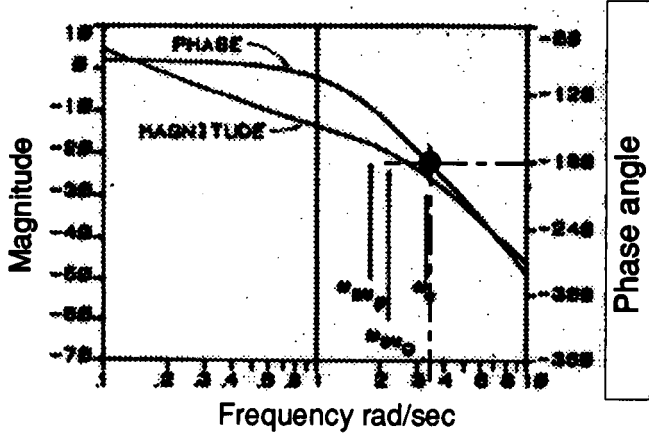

B) PIO at altitude
 Actual PIO frequency = 0.49 Hz
 -180° phase frequency = 0.52 Hz

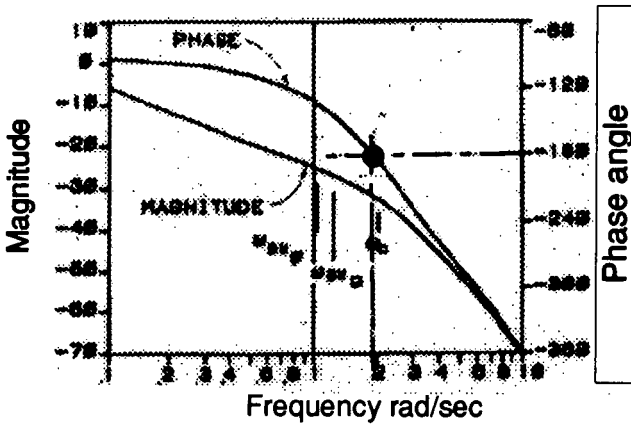

C) Cockpit display PIO
 Actual PIO frequency = 0.32 Hz
 -180° phase frequency = 0.32 Hz

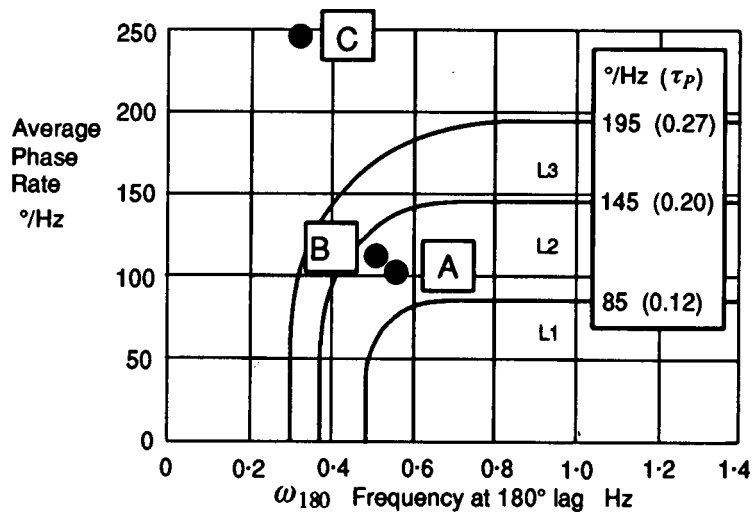

Taken from:
 J.Guidance July-August 1984
 Prediction and occurrence
 of pilot induced oscillations
 Twisdale, Kirsten

Figure 11 Shuttle orbiter PIO examples

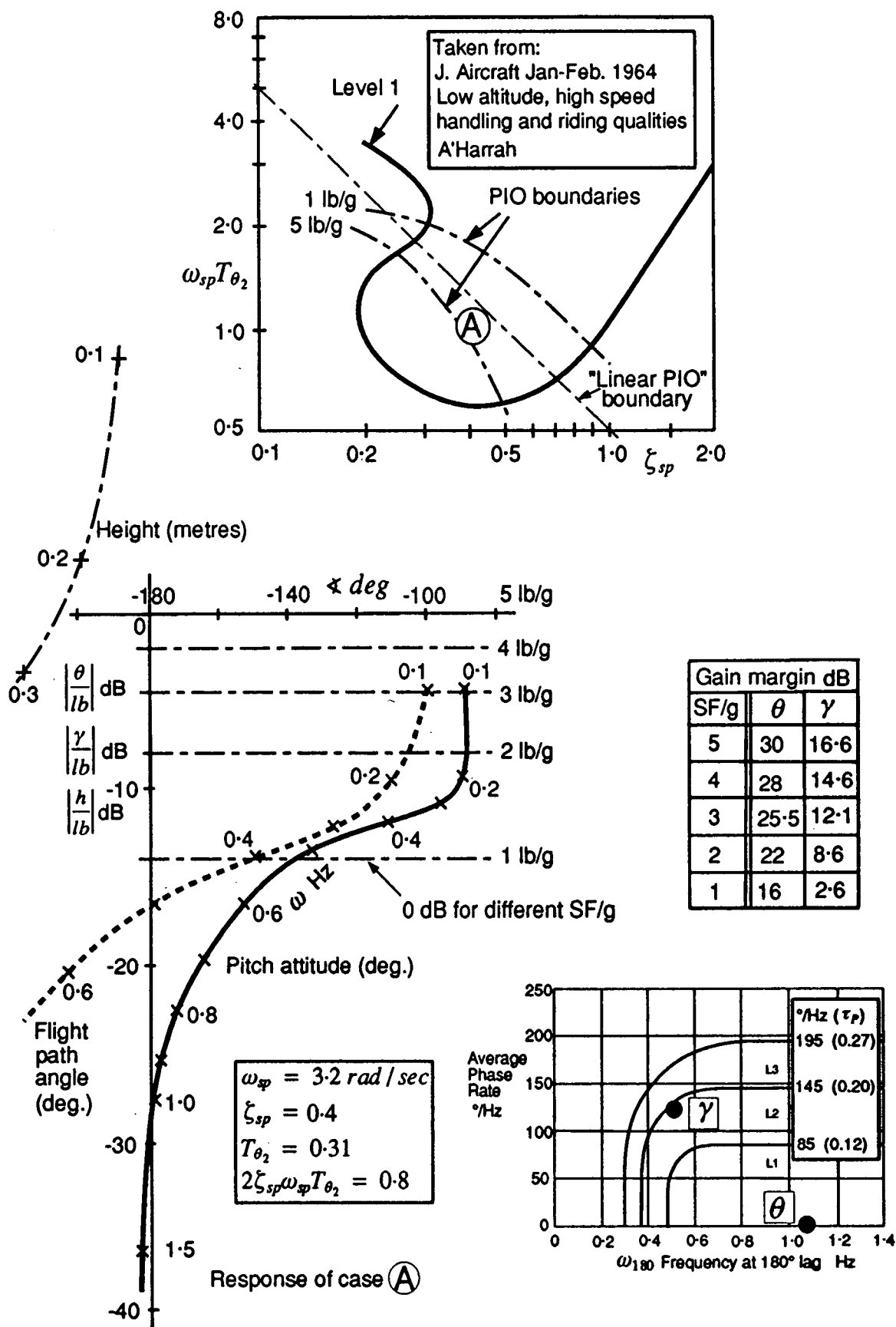

Figure 12 Probable height-related PIO

The Relation of Handling Qualities Ratings to Aircraft Safety

Mr. John Hodgkinson
McDonnell Douglas Aerospace
Transport Aircraft Unit
Dept 1XM, Mail Code 36-41
3855 Lakewood Blvd.
Long Beach, CA 90846
United States

1) **Introductory Remarks**

Before making the presentation, a few comments were offered regarding the experiences with PIO with which MDA and their forerunner companies have been involved.

Firstly, the F-4 accident, captured in film during the speed runs at White Sands, followed when the pilot was undertaking a 3g turn onto the line for the run. The pilot had trimmed the aircraft before the run to pitch up in the event that he let go and decided to abort the speed run. In the event, during the turn, a roll PIO started and he failed to let go in time to save the aircraft.

Recently, one of the new products had also run into problems with PIO. A rate limit of 12.5°/sec. had been introduced on the pitch control due to possible loading problems on the tail. Whilst this was opposed by handling qualities specialists, the change had been implemented and the aircraft had subsequently encountered the predicted PIO.

This brought the presenter to the main theme of his presentation, that of relating the handling qualities issues, and specifically the PIO, to aircraft safety. It is essential that the programme managers recognise that PIO is safety critical in that it is loss of control, and that when it is encountered, it is as dangerous as a structural failure of the airframe.

2) **Accident Statistics, Adverse Weather and Implications for Design for Safety**

Air accident statistics collected from 1960 to 1991 clearly indicate that air travel has been, and continues to be, an extremely safe mode of transportation. Improvements in safety can be largely attributed to the emphasis placed by manufacturers on technologies such as fail-safe design for structure and systems. However, the improvement has seemed to approach an asymptotic limit near 4 accidents per million departures.

Many of the accidents which still occur happen during poor weather conditions of low visibility, rain, fog, snow slush, cross winds, etc. The data indicate that maybe you cannot

design a better pilot and that human error cannot be suppressed. Alternatively, a question could be asked, "Why is it, that these carefully selected, highly trained men and women who are thoroughly checked for health, who demonstrate high standards of discipline and awareness, who are continuously undergoing refresher training are actually held responsible for many of these accidents?"

A different approach is considered here.

The notion of "pilot error" represents a pilot stressed to failure. It is assumed roughly equivalent to loss of control, loss of the aircraft and loss of continued safe flight or landing. It is not considered as a pilot mistake. As the accidents seem to indicate the total absence of mechanical aspects, but the effects of weather are significant, this latter seen to be the major factor in the analysis. Design for safety in adverse weather holds promise for a highly leveraged means of improving safety.

3) **Current Design Philosophy**

Current design techniques centre around four safety tools

1. Function Hazard Analysis
2. Failure Modes and Effects Analysis
3. Fault Tree Analysis
4. Zonal Analysis

Use of these techniques has reduced the effects of equipment failures such that they are very infrequent causes of accidents. The effects of weather are not subject to such rigorous assessments. The poor weather, all-up-aircraft state is not yet explicitly addressed in the requirements. Improving aircraft safety in adverse weather without mechanical failures might have a major impact on overall safety. More and more, designers are becoming aware of the effects of low-level, chronic disturbances which can have just as damaging consequences as acute stress. In such circumstances, the increase of loss of control probability associated with adverse

weather can and does add up to become a chief contributor to the deterioration of flight safety.

It is important to have a set of criteria for allowable aircraft handling qualities in the face of adverse weather. Such criteria should allow numerical relationship between atmospheric weather states and allowable handling qualities.

4) Development of a Relation of Flying Qualities Criteria and Loss of Control

One possible way to apply the FAR design criteria of FAR25-1309 is to require the aircraft be protected from a postulated "loss of aircraft due to loss of control in a particular weather type" with the same 10^{-9}

per flight hour safety standard. Reference 1 presents an analysis which takes the probability of a gust encounter based upon r.m.s. gust intensity and the associated probability of loss of control and then approximates the probability of the pilot's losing control by multiplying the probability of encounter of a gust of a particular intensity with the probability of the loss of control due to that level of gust.

Whilst the analysis has been performed for aircraft entering into adverse weather conditions, the effects of PIO are very similar, in that they also represent aircraft loss of control, although possibly due to different cause. Nevertheless, the same logic and arguments can be applied, and indeed, the effect of PIO susceptibility may well be a major contributor to the problems with adverse weather where a close control task is required, approaching touchdown.

The Cooper-Harper scale represents a workload metric which can be related to the probability of losing control of the aircraft during any particular task, for a give scenario consisting of

1. the aircraft's equations of motion and associated handling qualities,
2. a task,
3. an assumed failure state,
4. the weather state,
5. any disturbance state of interest,
- 6.
7. etc.

Examination of the Cooper-Harper handling qualities rating scale gives a rating of 9 the interpretation that the aircraft will suffer occasional loss of control, whilst a rating of 1

indicates that the handling is excellent with no pilot compensation required to achieve the desired performance..

If the Cooper-Harper rating distribution is recorded for a given task as a random normal variable, then a relationship between CHR and the probability of loss of control, as shown in the figure, is achieved.

If an analysis is performed on an aircraft's control system, then the design goal is for catastrophic failures to occur with a probability of $\leq 1 \times 10^{-9}$ per flight hour, or effectively never within the aircraft's operational life in a large fleet of aircraft. By analysis, it is possible to show that this coincides with the Cooper-Harper Rating of ≤ 3.5 , as shown in

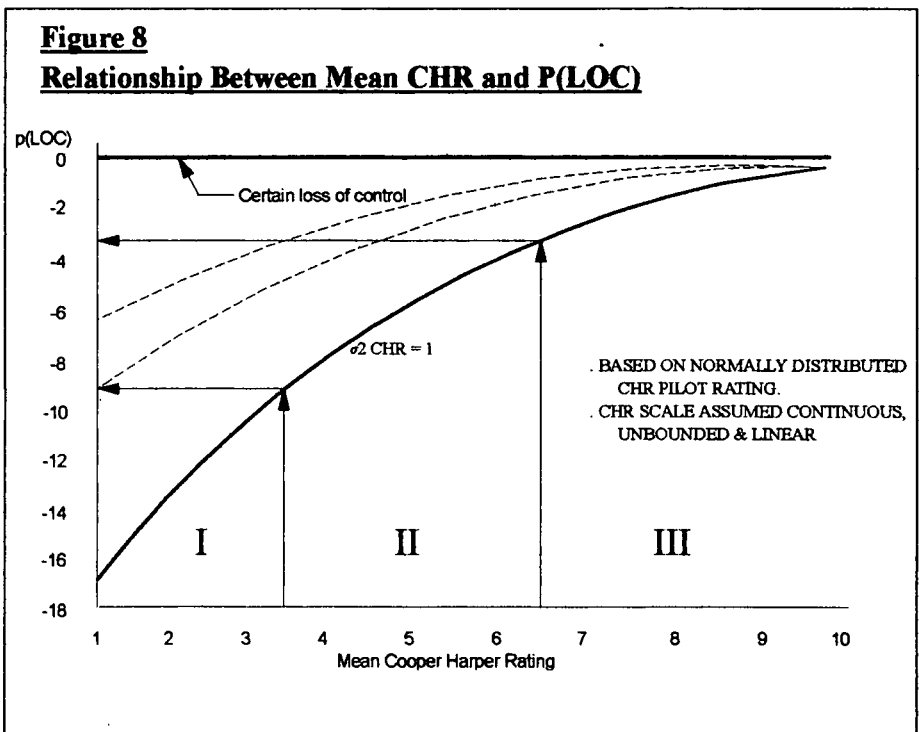

detail in reference 1.

Similarly, the analysis can be extended to show that CHR 6 corresponds to probabilities of loss of control of $\leq 10^{-3}$. This is summarised in the figure, where Level I, Level II and Level III have been equated to the probability of loss of control, based upon the results of the simulation studies performed..

5) Concluding Remarks

The results which have been derived form this analysis indicate how the safety of aircraft may be improved by ensuring the aircraft are designed to have good overall aircraft flying qualities and freedom from PIO susceptibility. Whilst the analysis was originated for the effects of adverse weather, it can be extended to cover the effects of PIO susceptibility.

The primary object behind this exercise is to educate the management team as to the worth of having good, i.e. Level I, handling qualities, especially for large passenger transport

aircraft, when conventionally this might not be the case, and significant safety improvements may be obtained.

The scenario that can be postulated is the occasion when all the adverse events happen together and the pilot for some reason has to make a correction, e.g. a side-step on approach, whilst coping with other events. It is under these conditions that the pilot gain can increase to the point where the system no longer responds properly and the PIO is entered.

Having good handling to start off with provides that extra margin which, under such circumstances, can lead to the avoidance of an incident or accident, as even if the handling degrades, it is unlikely to become unsafe. However, if the aircraft is Level II to start off, then under such conditions, it may well enter Level III or worse.

Reference

1. AIAA93-31059
"Flying Qualities for Adverse Weather"
D.Gillette, M.Page, J.Hodgkinson

Experience of the R.Smith Criterion on the F-15 SMTD Demonstrator

Mr. David J. Moorhouse
S/MTD Chief Engineer
Wright Laboratory, WL/FIMS
Building 450, 2645 5th St., Ste 16
Wright Patterson AFB
Ohio 45433-7922
United States

aircraft and the assessment of the PIO proneness from prediction compared to the flight experience.

1) Introduction

Before making his presentation proper, Dave Moorhouse added some information regarding the YF-22 incident. The aircraft was making a second low pass over the runway with very little pilot activity when the event commenced. The trigger was within the aircraft, as the selection of the gear was made. He confirmed that the pilot was unaware of the PIO, but that he had the impression that the aircraft had "broken" in some way that he did not understand.

He concluded from this incident that, with any flight control system, **there is always a trigger** and that the only way to proceed is to adequately stress the system by ensuring that aggressive flight tasks are evaluated and then **fix the system** if any adverse problems are encountered.

2) Experience with the R.Smith Criterion

As a manager, he stressed that part of the problem is the seeking of a yes-no answer and that what was not needed was the advice from specialists arguing over whether or not there is a problem. His experience was generated from application of the R.Smith criteria as an absolute to both the F-22 and the F-16 MATV aircraft. This had shown the effects of the added thrust vectoring capability to be zero. He reported that there would be a paper published at the AIAA conference on the subject of the effects of rate limiting seen in flight of the F-15 SMTD aircraft.

He recommended that people involved in assessing PIO should utilise the R.Smith criterion, but should modify their application of it. The intended paper for the AIAA meeting would address the experience of Flight Simulation, a discussion of the Neuromuscular cues which a pilot might receive and how the Ralph Smith Criterion should be modified in its application. Included in the content would be the effects of the eddy-current stick damper designed for the

The key to understanding the sensitivity of a design was to set up a task which would adequately stress the system, for example by setting up an HQDT type task for a landing approach condition. In the case of the F-15 SMTD, this had not revealed the problems indicated by the criterion, although there had been some evidence of the aircraft being close to the outbreak of a PIO due to the effects of actuator rate limiting.

A debate followed, predictably, regarding what had occurred and whether or not there had been a problem. Ralph Smith maintained that a problem had indeed occurred, although Dave Moorhouse stated that he was not aware of any adverse behaviour, other than that which he described.

Reference

1. D.J.Moorhouse
"Experience with the R.Smith Criterion on the F-15 STOL and Maneuver Technology Demonstrator"
AIAA Paper 94-3671

(Editor's Post-Meeting Note: This discussion resumed at the AIAA meeting in August, 1994. As a result of the comments made at Turin, Dave Moorhouse had reviewed all of the F-15 SMTD data and had found the undesirable characteristics which had been reported by Ralph Smith. He also reported that he was previously unaware of the information).

SCARLET: DLR Rate Saturation Flight Experiment

Jennifer R. Martin
 Jörg J. Buchholz
 Institut für Flugmechanik
 Deutsche Forschungsanstalt für Luft- und Raumfahrt e.V.
 Lilienthalplatz 7
 38108 Braunschweig
 Germany

SUMMARY

The time delay which arises due to rate limiting in a control system has been identified as a contributing factor to the occurrence of pilot induced oscillations (PIO's) (Ref 1). Recent discussions concerning PIO prevention measures have proposed the elimination of this time delay through an alternate control scheme (Ref 2). In response to this proposal, the SCARLET (Saturated Command And Rate Limited Elevator Time delay) project was initiated in order to study the effects of both the time delay and the elimination scheme on the handling qualities of a contemporary fly-by-wire aircraft.

A flight experiment was carried out in 1992 using DLR's ATTAS In-Flight Simulator (Ref 3). The flight test included runs with two different control laws: a conventional control scheme and the alternate control scheme (ACS). Results of the experiment demonstrated both the negative effect of rate saturation and the effectiveness of ACS to reduce the equivalent time delay and improve tracking performance.

In order to further validate the concept of an alternate control scheme, the algorithms were adapted for use with a model-following control system. Pilot-in-the-loop simulations have shown improved performance through the use of ACS during rate saturated conditions. A second flight test will be performed this year in order to further evaluate the use of the alternate control scheme to eliminate the rate limit induced time delay and reduce the danger of PIO.

1. INTRODUCTION

1.1 The Problem

Actuator rate saturation can lead to a significant time delay between the actuator input and the actuator output. This time delay arises due to the interaction of two rate limited elements in the control system: the actuator itself, and the *command* to the actuator (actuator input). The actuator is rate limited due to 'real-world' effects. Fig 1 depicts a typical actuator consisting of a motor or hydraulic booster and a controller. The error between the actuator command and the output is calculated by the controller and used to drive the motor. The motor, however, can only respond with a limited rate due to constraints in electric current or hydraulic flow. The actuator command, on the other hand, is intentionally limited, either by a software rate limiter somewhere in the control system, or simply by the pilot, if the stick is moved with a limited rate.

Consider now a situation in which the rate limited command is faster than the actuator, as shown in Fig 2. In the first time period ($0 < t < t_1$), the actuator strives to reach the command with its maximum rate; however, a discrepancy will develop between the magnitudes of the command and the output due to the difference in rate limits. When the command then changes direction at t_1 , its magnitude is greater than that of the actuator output, and therefore the command begins to move *into* the direction of the output while the actuator continues in its *original* direction as it tries to meet the command. Only when the magnitudes of the two signals meet at t_2 will the actuator finally change direction to follow the command. The time period between the reversal of the command and the reversal of the actuator output is the time delay T_D .

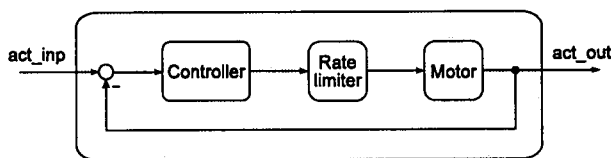

Fig 1 Actuator

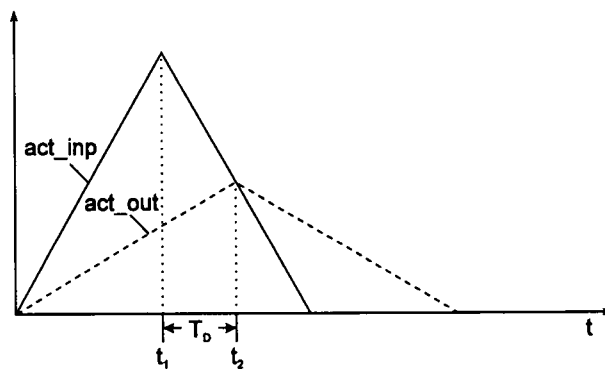

Fig 2 Time delay

It can also be noted that the time delay will be maximum for some middle value of the rate limited command. If the commanded rate is only *slightly* faster than the maximum actuator rate, as in Fig 3a, then the discrepancy between the two signals and therefore the corresponding time delay will remain small. On the other hand, if the commanded rate is *much* faster than the maximum actuator rate (Fig 3c), then the discrepancy between the signals will be large, but the time between the reversal of the command and the point at which the magnitudes become equal again will be small. For the simple case shown here, the maximum time delay will be reached when the input rate is twice as fast as the output rate, as illustrated in Fig 3b. Thus it is important to note that only when the command is limited, and the rate limit is moderately faster than the maximum actuator rate, will the time delay be significant.

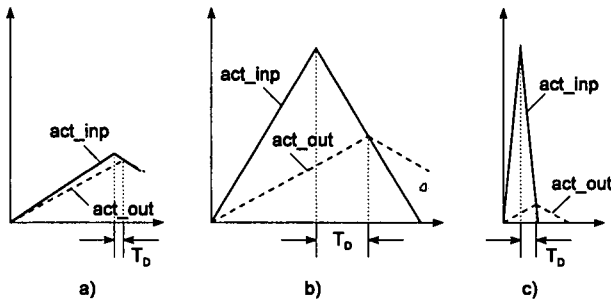

Fig 3 Different time delays

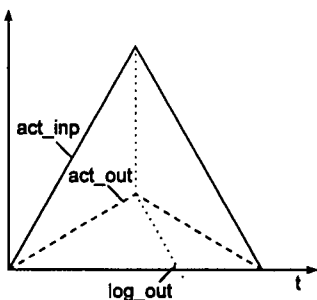

Fig 4 Time delay elimination

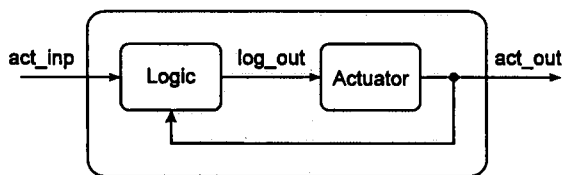

Fig 5 Smart actuator

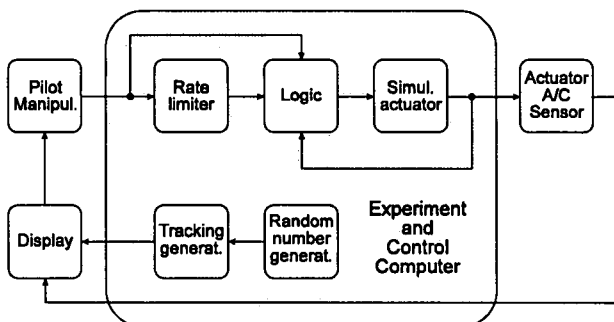

Fig 6 The experiment

1.2 The Solution

The time delay could be eliminated if the actuator reversal occurred at the same point as the command reversal, as shown in Fig 4. Therefore, a solution is suggested through the following Alternate Control Scheme (ACS) (Ref 2):

If the actuator is rate saturated, then coordinate the reversal of the actuator rate with the reversal of the command.

The ACS can be implemented through the use of a logic block placed directly before the actuator in the control loop, as depicted in Fig 5. The actuator command from the control system is fed into the logic block. The logic then determines whether ACS is required based on information about the command and the actual actuator output. When ACS is to be activated, the logic block provides an output signal which serves as a new actuator input. This modified input is calculated to produce the desired actuator output. If ACS is not required, then the logic block simply passes on the normal actuator command as input to the actuator.

This process is clearly illustrated in Fig 4. In the first time period the command demands more than the actuator can achieve, such that as before a discrepancy develops between the magnitudes of the signals. However, when the command changes direction, the logic switches on and produces the output shown, which serves as the *new* actuator input. The actuator now strives to follow the logic output and thus changes direction *immediately*, and therefore the time delay disappears. The basic design philosophy is that when conditions are right for the occurrence of the time delay (i.e. the actuator is saturated), then the normal control system structure is bypassed, and the information about the command reversal is passed *directly* to the actuator. Thus the time delay is eliminated.

2. FLIGHT TESTING

2.1 The Experiment

In order to evaluate the solution strategy, a flight test was performed using DLR's In-Flight Simulator ATTAS (Advanced Technologies Testing Aircraft System). ATTAS's Experiment and Control Computer (ECC) is depicted in Fig 6. The slow rate limit of the actuator was simulated using a software rate limiter, such that the ATTAS actuator never reached its true saturation state. This rate limiter is portrayed as the 'simulated actuator' block. A second rate limiter was used to limit the actuator *command* (pilot input). This rate limit was set such that the maximum time delay would be produced, so that the time delays could be seen clearly. A tracking generator supplied a pitch angle tracking task for the pilot to follow. The pilot compared the commanded pitch angle on the display with the actual pitch angle of the aircraft and then closed the outer feedback loop using the stick deflection to command an elevator deflection. Thus in this experiment, the actuator input was directly proportional to the pilot command. The ECC also contained the Alternate Control Scheme algorithm in a logic block. Test runs were flown using two different control laws, CCS (Conventional Control Scheme) and ACS. With CCS, the logic block was a simple one-to-one feedthrough and thus the normal aircraft was flown. With ACS, the logic block was active and provided a modified input to the actuator when necessary. This setup allowed the effects of the ACS to be evaluated and compared with the unmodified configuration.

2.2 Test Results

The time histories of the test runs demonstrate the advantage of ACS. Fig 7 shows the results of a test run with a very slow elevator and the Conventional Control Scheme. The tracking task represents the desired pitch angle; the actual pitch angle of the aircraft is also shown. By comparing these two curves it can be clearly seen that the pilot was *unable* to fulfill the tracking task. The presence of the time delay created undesirable coupling between the aircraft and pilot. Oscillations developed which increased in amplitude until about 50 seconds, at which point the pitch angle became so

large that the maximum allowable speed was exceeded and the safety pilot took over control. With ACS, however, the pilot was able to follow the tracking task much more closely, as shown in Fig 8. Although there is still significant discrepancy between the desired and actual pitch angles due to the extremely slow elevator, the correspondence between the curves is much higher and oscillations did not develop. There was no apparent tendency toward undesirable aircraft-pilot coupling. In general, the flight test data demonstrates that the use of ACS decreased the equivalent time delay and the tracking error.

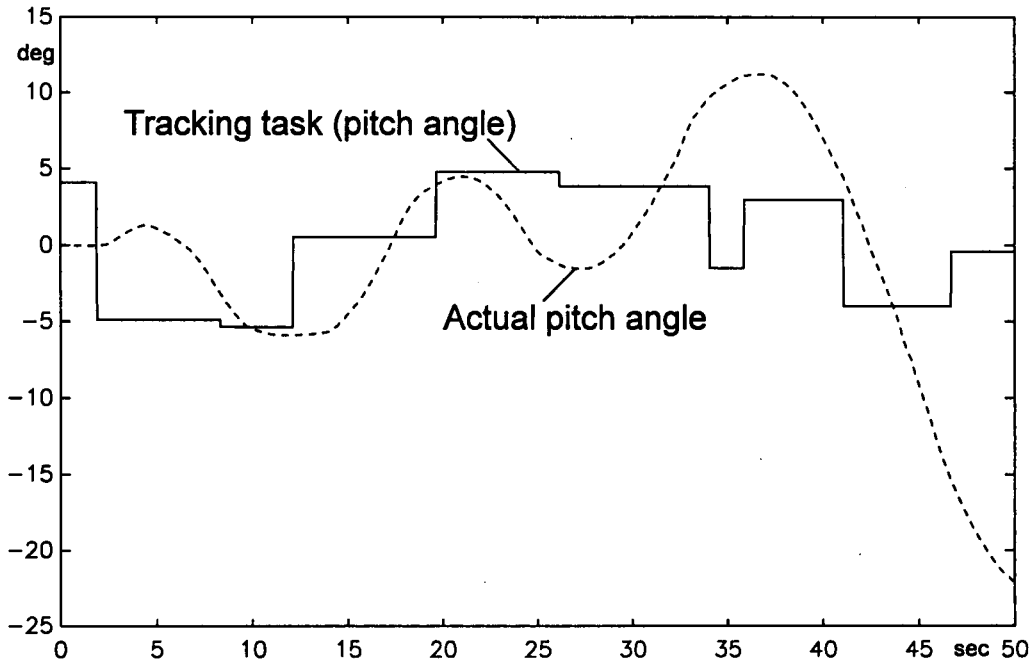

Fig 7 Conventional control scheme

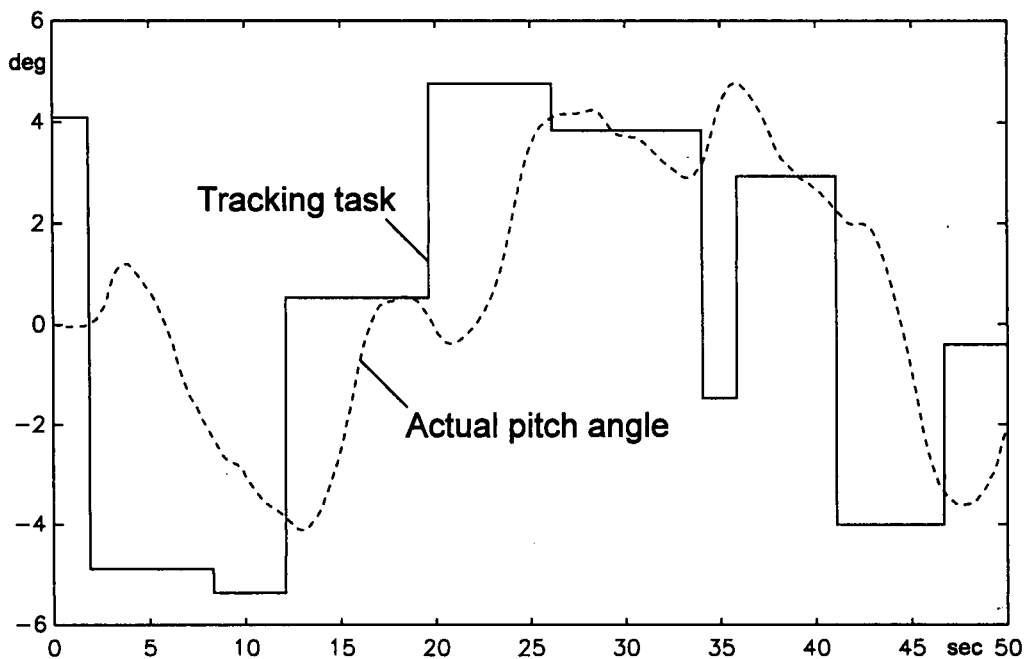

Fig 8 Alternate control scheme

3. EXTENSION OF ACS CONCEPT

3.1 Model-following Control System

The next step of the project was to extend the application of ACS to a more complex and realistic control system. For this purpose a model-following control system was chosen as illustrated in Fig 9. In this type of system the actuator input is no longer proportional to the stick deflection. Rather, the pilot input is forwarded to a model, which calculates the desired aircraft response. The output of the model is then used in the feedforward block to calculate the necessary control input to the real aircraft which will produce the desired response. In order to compensate for disturbances and model uncertainties, a feedback loop compares the model response with the actual aircraft response and calculates the error. The sum of the feedforward command and the feedback command becomes the input for the actuator. In addition, a rate command control law was implemented at the stick, such that the stick deflection is proportional to a commanded aircraft rate. The pilot command is therefore no longer directly related to the actuator input. Although the same ACS strategy can be used in this case, the control system differences dictate that the ACS activation criteria must be based on the *pilot* command instead of the actuator input. Thus as shown in Fig 9, the logic block uses information about the pilot command and the saturation state of the actuator in order to determine whether ACS is necessary.

The underlying idea is to 'meet the pilot's expectations'. The pilot makes an input at the stick and consequently expects a change in the aircraft's motion. Normally the forward path elements (model, feedforward) transform the pilot inputs into actuator commands which will produce the expected response. However, when the actuator is saturated, then the normal control law issues commands which the actuator *cannot* follow. When there is then additionally a reverse in the command, as was illustrated in Fig 2, the time delay arises and prevents the aircraft from responding immediately to the pilot control inputs. However, because the pilot *expects* a change from the aircraft, the lack of one can lead the pilot to make a *larger* control input in an attempt to produce a response. In general this creates the type of high-gain closed-loop feedback which can lead to undesirable aircraft-pilot coupling. In this situation, ACS should be activated such that the actuator

reacts as quickly as possible when the pilot commands a change in the aircraft motion. This will in turn ensure that the pilot's expectations are met. In order to accomplish this, the logic block checks the actuator saturation state and the pilot command- when the actuator is saturated and the pilot commands a change, the normal control system is bypassed and the pilot commands are forwarded directly to the actuator. This scheme eliminates the time delay and thus reduces the potential for PIO's.

3.2 Simulation Results

Pilot-in-the-loop simulations were carried out as a first step in evaluating the extended implementation of ACS. The simulations were configured similarly to the first flight experiment in that the pilot was given a tracking task to follow and tests were performed with both the CCS and ACS control laws. A comparison of the two schemes is shown in Fig 10. Once again it can be seen that with a rate limited actuator and CCS the pilot was unable to follow the tracking task, and large amplitude oscillations developed as a result of aircraft-pilot coupling. For the same configuration, ACS led to much better tracking accuracy and smaller system amplitudes.

The source of this improvement can be seen by comparing the pilot input, actuator command and actuator reaction (Fig 11). In the CCS case, the pilot inputs lead to control system commands which the actuator cannot follow. A comparison of the slopes of the control system and actuator curves shows that the control system command rate is much faster than the actuator can achieve. The constant slope of the actuator indicates that the actuator rate is saturated. The time delays can be seen explicitly in this time history as the distance between the reversal of the control system command and the reversal of the actuator. The corresponding ACS time history shows the disappearance of the time delays. Although the pilot inputs in this case also lead to control system commands which the actuator cannot follow, ACS ensures that the actuator reverses immediately when the pilot commands a change. Thus the time delay does not occur. This can be seen by comparing the control system and actuator traces and noting that the two curves always reverse at the same time.

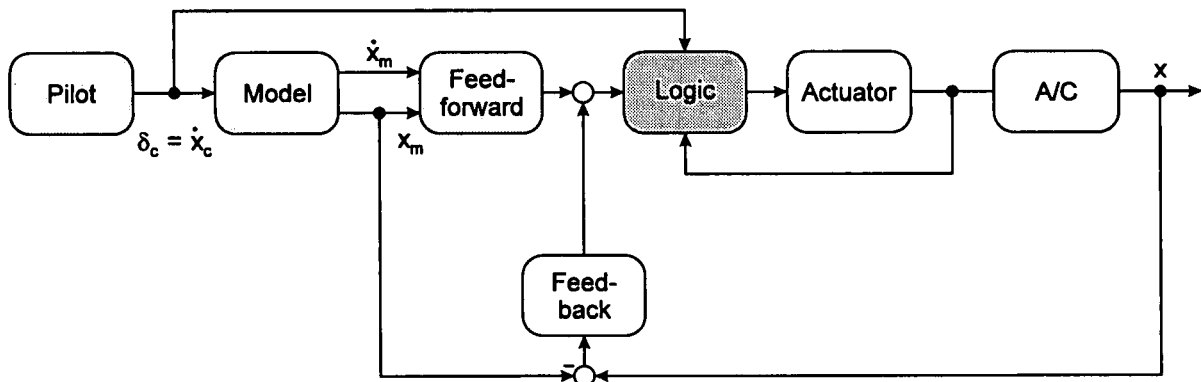

Fig 9 Model following control system

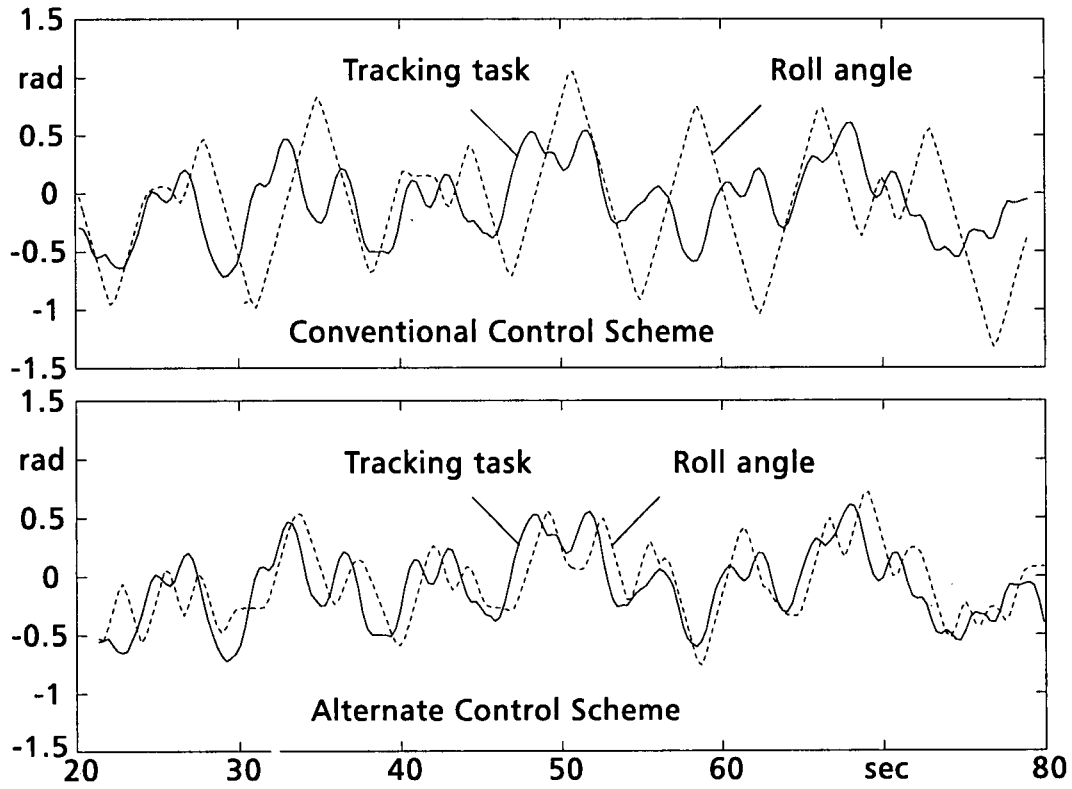

Fig 10 Pilot-in-the-loop simulation

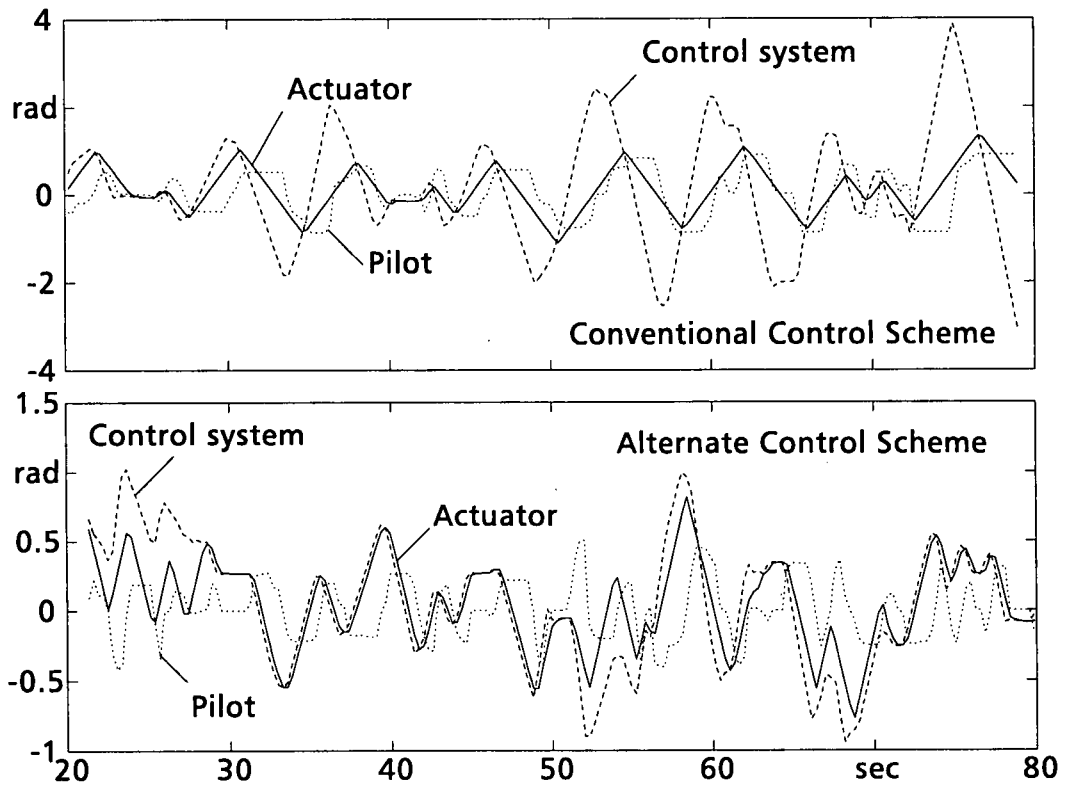

Fig 11 No time delay with alternate control scheme

This lower figure also illustrates the fact that ACS only activates when necessary, i.e. when the actuator is saturated. In regions where the pilot inputs are moderate and the actuator can follow the control system commands without saturating, ACS remains off and the normal control law is used. This situation occurs between approximately 30 and 50 seconds, where the actuator curve follows the command curve very closely. However, if the pilot, for whatever reason, makes a sharp input which produces a commanded rate *greater* than the actuator can achieve, then ACS switches on and ensures that the pilot's expectations are met. This scenario occurs in the latter half of the trace. At approximately 51 seconds the pilot pushes the stick sharply, and the resulting divergence of the control system and actuator curves indicates that the actuator has saturated. When the pilot then commands a change in direction at about 52 seconds, ACS switches on and the actuator changes direction immediately. The actuator remains saturated for most of the next 20 seconds or so, and the coordination of the actuator and command reversals through ACS can clearly be seen. Once the commands are reduced and the actuator can again satisfy the demands, the system returns to the normal control law. This occurs at approximately 72 seconds, beyond which the actuator once again follows the control system closely.

4. CONCLUSIONS AND FUTURE PLANS

The SCARLET project to date has successfully demonstrated the ability of ACS to reduce the negative effects of rate limit induced time delays, and has also shown that the basic strategy can be extended to more complicated control systems. Currently a second flight test is being prepared to further evaluate the application of ACS to a model-following control system. While the first flight test demonstrated the advantageous application of ACS to reduce the closed loop time delay, during the next flight test emphasis will be shifted to obtaining extensive pilot ratings and feedback in order to more closely evaluate the benefits of ACS with regard to flying qualities.

5. REFERENCES

1. McRuer, D., "Human Dynamics and Pilot-Induced Oscillations", Minta Martin Lecture, Massachusetts Institute of Technology, December 1992.
2. A'Harrah, R.C., "Communiqué with DLR and others", NASA HQ, Washington, D.C.; 1992.
3. Buchholz, J.J., "Time delay induced by Control Surface Rate Saturation", Zeitschrift für Flugwissenschaften und Weltraumforschung, 17, 1993, pp 287-293.

SAAB Experience with PIO

E. Kullberg
&

Mr. Per-Olov Elgcrona
Specialist, Flight Control
SAAB-SCANIA AB
SAAB Military Aircraft
Tumstigen 5
S-58266 Linköping
Sweden

1) Introduction

In their presentation Per-Olov Elgcrona and Erik Kullberg reviewed the past experience in Sweden with PIO, which had been so publicly witnessed with the second accident to the JAS-39 aircraft at the Stockholm Water Festival.

Prior to commencing on the JAS-39 project, SAAB's experience of the PIO phenomenon had commenced with the J-35 aircraft. This aircraft had high stick sensitivity combined with a linear gearing of the stick to elevator. Following the PIO, the solution devised was to add a non-linear gearing and improve the stability augmentation of the system.

For the next aircraft project, the AJ-37 Viggen, significant work was performed on the handling qualities and resistance to PIO, based upon new information received during the 1960's from Ashkenas, McRuer and A'Harrar. By 1963, Sweden had developed its own specification for flight control system design and for handling qualities.

The latest versions of this AJ-37 aircraft have a digital flight control system. The AJ-37 Viggen has never experienced a problems with PIO in its service to date.

The JAS-39 flight control system originated from demonstration work performed by SAAB on a FBW AJ-37 Viggen aircraft. This aircraft had been flown with instability levels of up to 4% chord at low Mach Number. This was the limit for this aircraft. Although this aircraft was reported to have experienced Level 2 or 3 handling, due to excessive time delays within the flight control system, it never experienced rate limiting or PIO. On this basis, it was deemed that there was sufficient knowledge and confidence to proceed with the JAS-39 aircraft project, and the JAS-39 specification was written around this experience, with a demanding handling qualities requirement.

2) The Role of Actuation Rate Limiting

Examination of the time delay requirements in the fly-by-wire experiments resulted in the requirement to achieve Level 1

handling qualities, with a time delay of less than 100 milliseconds. The measured time delay, from flight test, was actually around 70 to 90 milliseconds in both roll and pitch axes. It was noted that this requirement resembles the recommendations of both MIL-F-8785C and Mil-STD-1797.

2.1) The First PIO Accident to the JAS-39

The design criteria used relates to the total time delay in the system. Whilst under ordinary linear circumstances, this can be achieved with comparative ease, once the actuator exhibits rate limiting, the effective time delay increases rapidly beyond 100 milliseconds.

Actuator rate limiting played a very significant part in both accidents to the JAS-39 Gripen. The first accident was described as a design error, in that the design was known to be sensitive prior to flight. However, the design process did not catch up with the evidence and require modification before flight. Following the accident, the whole process was reviewed and scrutinised with regard to the design of the flight control system.

The first accident started as a response to lateral turbulence with a control system which augmented the dihedral effect, making the aircraft very sensitive in roll. More than one presenter, who had been involved with Saab in the subsequent work, commented that the JAS-39 "mini-stick" probably had a very significant effect, as it requires only very small movements to demand full control and had a skewed axis. Once the rate limits were reached, the PIO developed initially in roll, then in pitch.

Examination of the Nichols plots shown in the figures will quickly reveal the impact of the rate limiting.

Further, on the JAS-39, the controls are used for both stabilisation and control, and there is thus competition between the requirements for the control capability. Clearly, if the pilot demand uses all the capability that is present, then there is no capability left for the stabilisation of the aircraft. The effect can be likened to approaching an invisible cliff

edge, all is acceptable until there is a sudden loss of control and the aircraft departs from controlled flight.

2.2) The Development of the "Fix"

Modifications to reduce the gain, which also reduced the manoeuvrability and agility at low speeds, were introduced and the aircraft was assessed using a HQDT test. Detail assessment enabled the establishment of a "footprint", from parametric variation of stick inputs in both pitch and roll, taking into account the effects of atmospheric disturbances such as gusts and turbulence, where rate limiting effects could be encountered, and hence these regions could be avoided.

Typical examples of the results of this assessment are shown in the figures which accompany this presentation. Using results of this, a criterion was developed which allowed the margins from rate limit, or the distance from the cliff edge, to be established. Within these bounds, the aircraft can be safely operated without any particular concern.

Typically, for a given system evaluation, the results of around 1000 landings would be examined for the effects and the presence of rate limiting. In this way, different control system designs could be evaluated. The more control activity a system showed, then the closer the system would be to the adverse effects of rate limiting and the consequent significant increase in the time delays which result.

However, as development progressed as planned through the flight test programme, there was a desire to boost agility at lower speeds and modifications were introduced. Assessment showed that under extreme conditions, using full roll and pitch stick, rate saturation and departure from stabilised flight could be reached. It was understood that it was vital not to reach rate saturation for any length of time as the effects of the reduced gain and additional phase lag would cause the aircraft to become unstable. The possibility of the "cliff edge" was found and action was taken, but unfortunately the wrong conclusions had been drawn.

The decision was taken to continue flying, as there were only a small number of aircraft involved in the test programme and all flying was to take place under very controlled circumstances which would minimise the possibility of any problems developing. It was known that for production, the problem had to be solved and the solution was defined some months before the second accident occurred.

2.3) The Second Accident to the JAS-39

A time history of the second accident, which occurred during the public demonstration at the Stockholm Water Festival, was shown. The second accident featured a roll PIO consequent upon the pilot aggressively rolling to wings level to accelerate in front of the crowd watching the aircraft. The roll input was sufficient to drive the actuation to the deflection limit and shortly after the rate limit was reached. This caused the aircraft to roll more than expected, so the stick was reversed, driving well into the rate limiting since the stick was demanding the limit of both deflection and rate. The figure showing the stick deflection in roll and pitch as a crossplot is

the record of this incident. With the rate limiting in effect, the inner stabilisation loops were ineffective. Analysis has shown that the effective time delay between pitch stick and pitch acceleration response increased from less than 100 milliseconds to around 800 milliseconds. The subsequent response and pitch up to high AoA caused the pilot to eject after 5.9 seconds, fortunately without causing any harm to the crowds on the ground or the pilot.

3) The Chosen Solution

In the short term, the objective is to restart the flight test programme for the aircraft. In the meantime a longer term solution is being designed around the concept of making the actuator reverse when the stick is reversed.

The solution being implemented on the JAS-39 is similar to that proposed by Ralph A'Harrah and tested in the Scarlet experiment at DLR and also on the Calspan Lear Jet. This works well to reduce the phase loss due to the actuator, but needs careful blending of the signals to avoid further problems due to the actuator not being at the demanded position. In addition, the effects of noise at around 10 Hz needs to be considered.

Assessments performed so far indicate that the revised control strategy is effective in controlling the response during stick pumping and when the stick is let go. However, one result is that the response to a step input is reduced, which tends to reduce the aircraft agility. This would appear to be an essential compromise, if aircraft safety and freedom from PIO is to be ensured.

4) Conclusions Regarding Pilot-Induced Oscillation

From the experience gathered within SAAB, the conclusions which can be drawn are summarised as follows:

1. That PIO susceptibility is independent of the type of flight control mechanism, i.e. whether or not the aircraft is FBW or conventional.
2. PIO is the result of "disharmony" between the pilot's action and the aircraft's reaction, i.e. there is an excessive time delay between the input and subsequent response.
3. The causes of PIO are now known to be associated with a susceptible aircraft, a demanding pilot task and a trigger event.
4. Within these factors, the aircraft susceptibility is the only one over which there is any consistent control. The other factors are associated with "chance".

Typical causes of PIO have been identified as:

1. A susceptible aircraft, e.g. a vehicle either high stick sensitivity or excessive time delay or phase lag.
2. System non-linearities, e.g. unblended changes in gain which are not controlled by the pilot, rate limiting of the control surfaces and excessive deadband in the stick sensor system.

FLIGHT TEST FUNCTION
 TIPSTEG TUNGT FPL, LST UTE
 H034 = 1978. Mech = 0.33

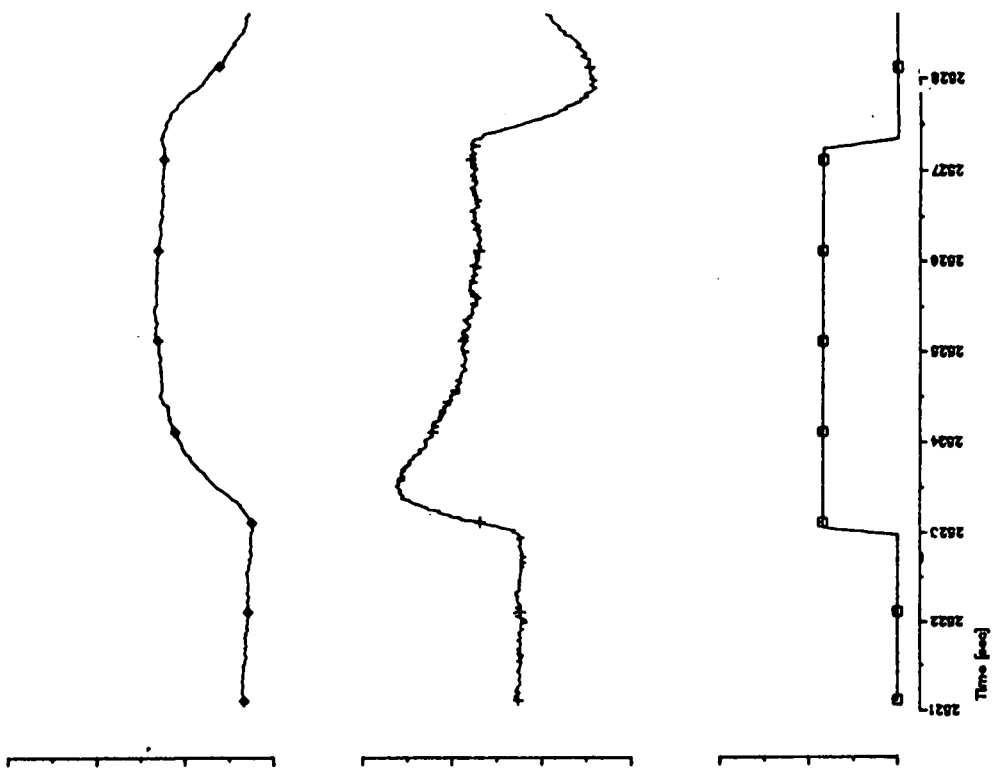

FLIGHT TEST FUNCTION
 TIPSTEG, LÄTT FPL, LST UTE
 H034 = 2014. Mech = 0.29

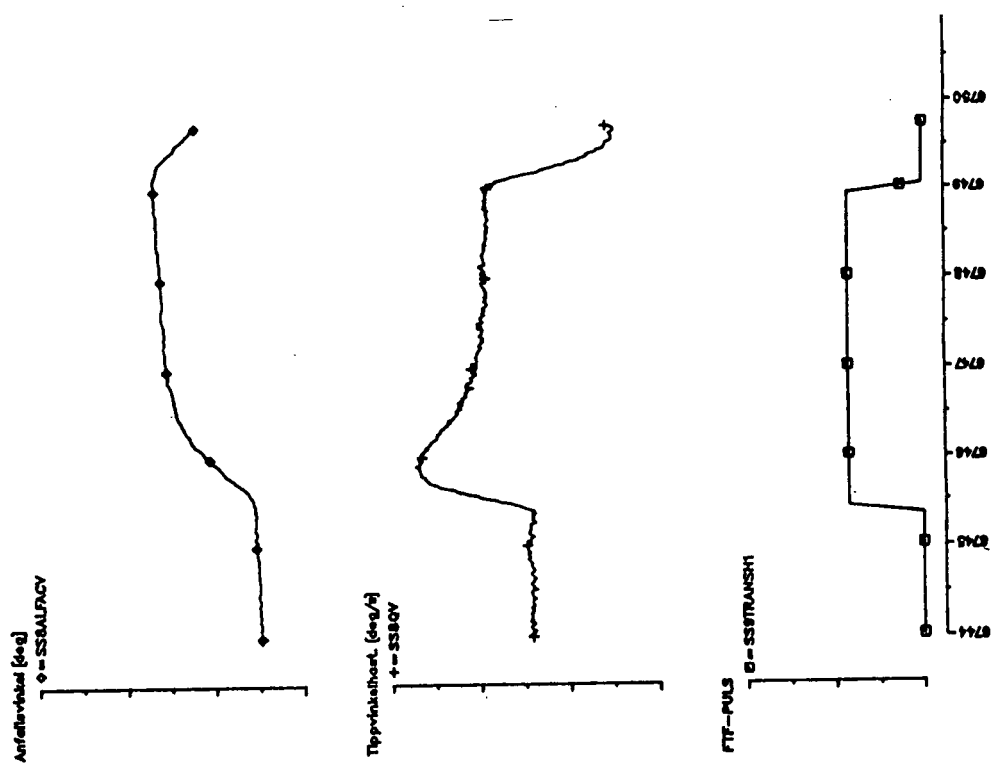

CAT-CIPA, L, H/M = 1/0.25
 Spak gradient: 0.40

- 1: NOM;J2, J4137, 4345
- 2: NOM;J2, K5755, 3200
- 3: NOM;J2, K5756, 5786
- 4: NOM;J2, K5757, 4046
- 5: NOM;J2, K5757, 4245
- 6: NOM;R+FTL, J4215, 4197
- 7: FTF;J2, J4137, 5047
- 8: FTF;J2, K5756, 5556
- 9: FTF;J2, K5757, 4676

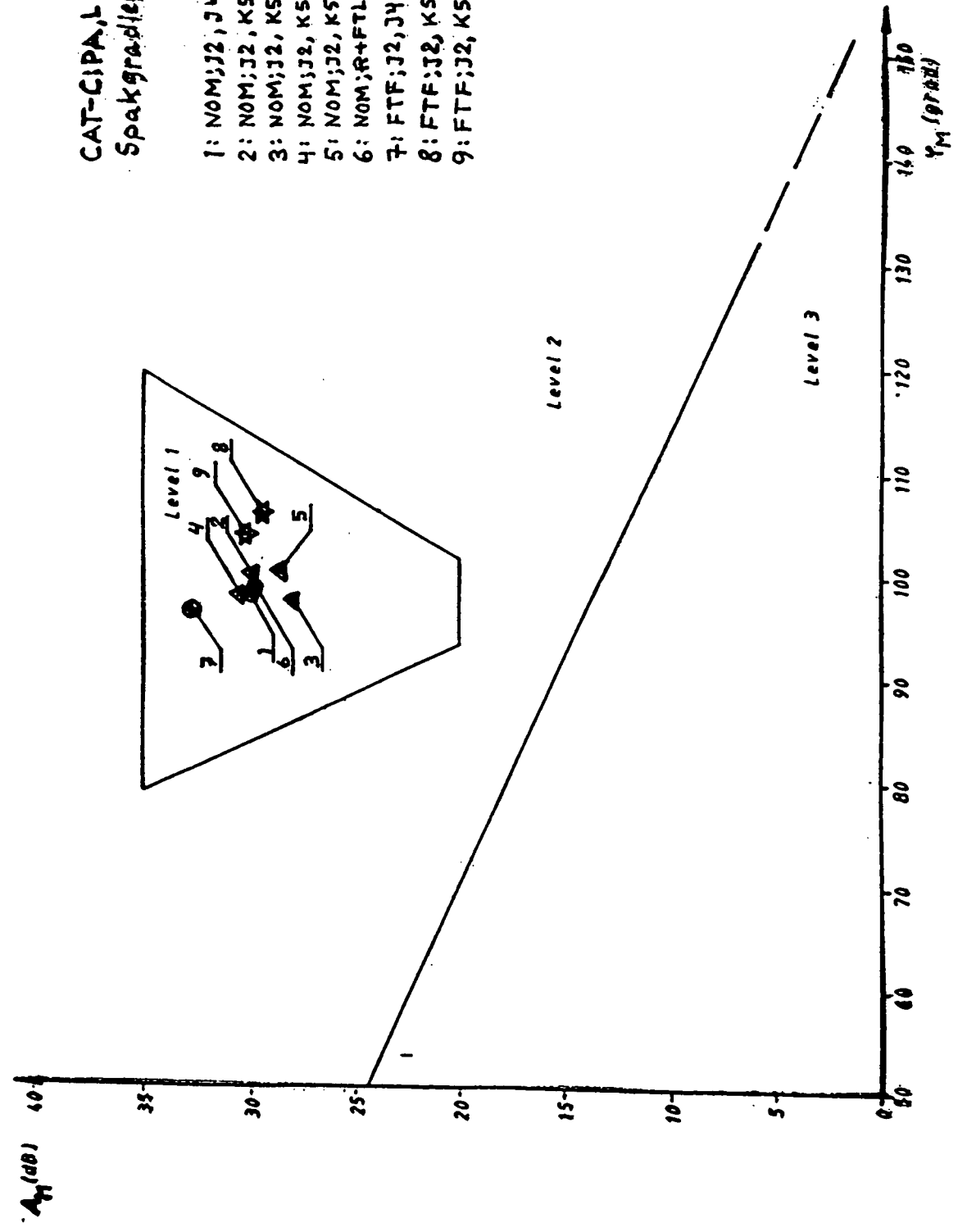

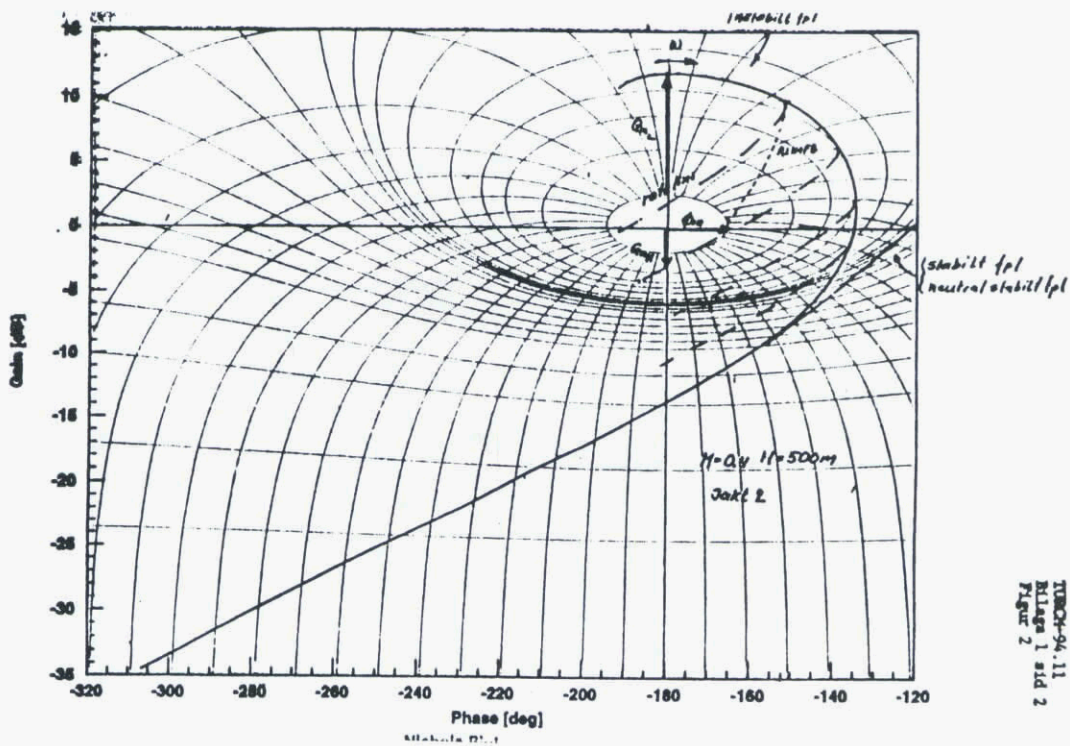
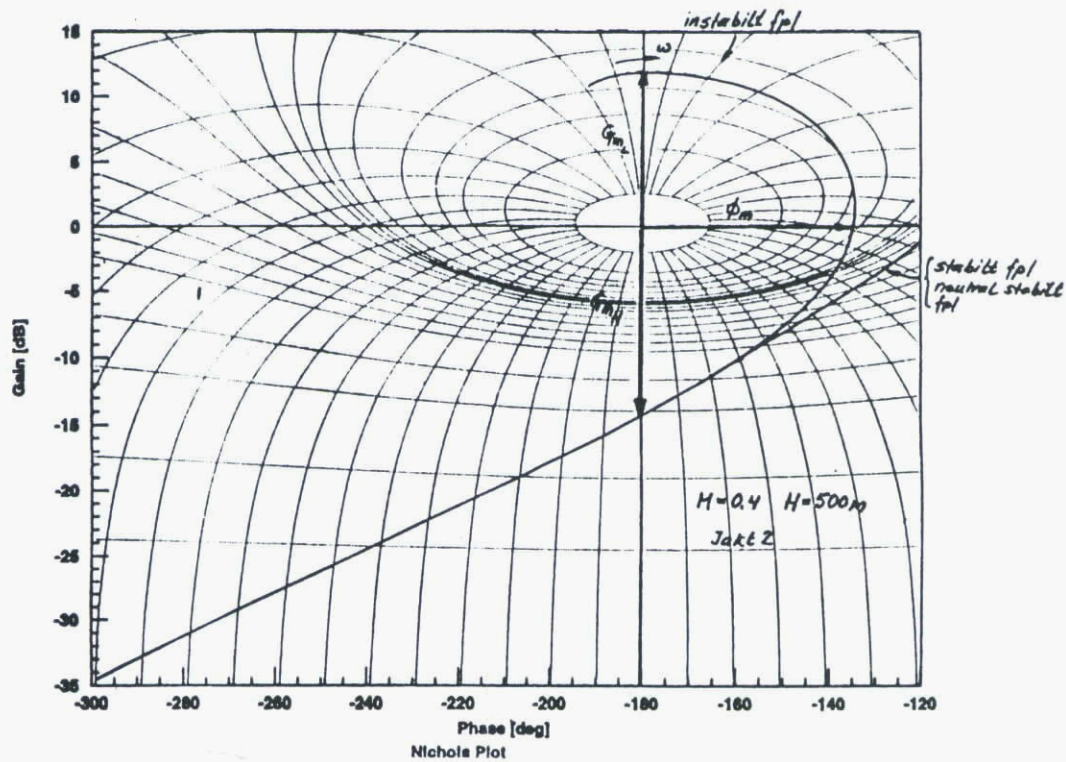

TIMON-94-11
 Bilaga 1 sid 2
 Figur 2

SPECIAL CONSIDERATIONS.....(cont.)

Control surfaces are used both for stabilisation and manoeuvring ("competition")

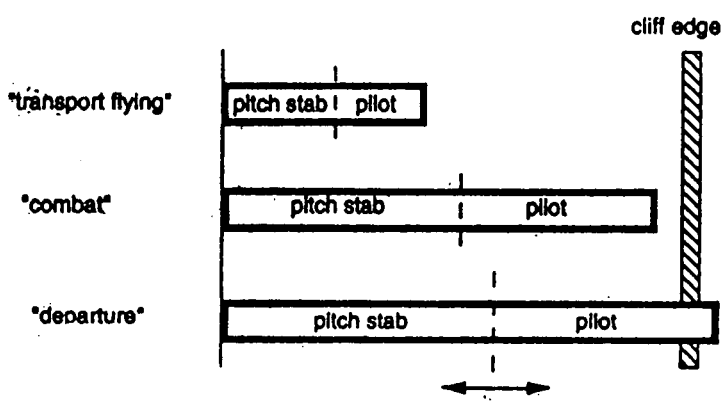

JAS 39 Flight Control System

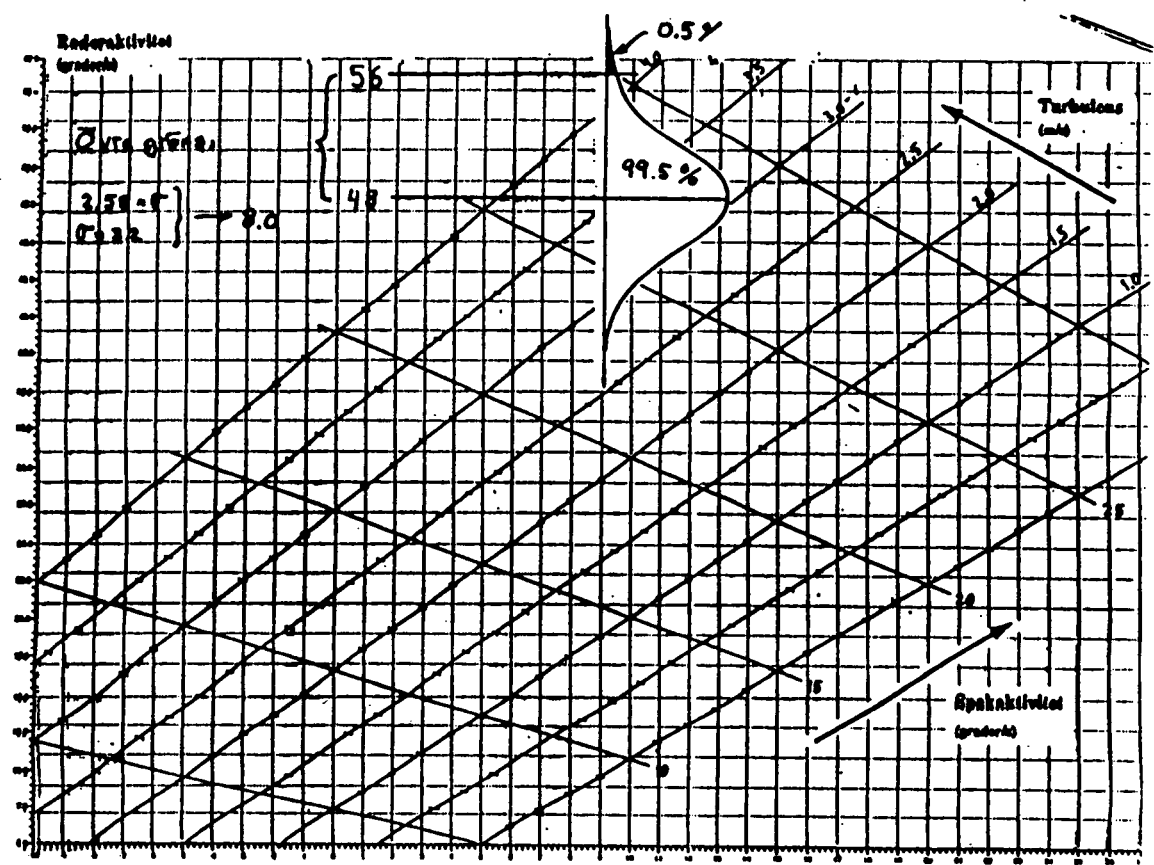

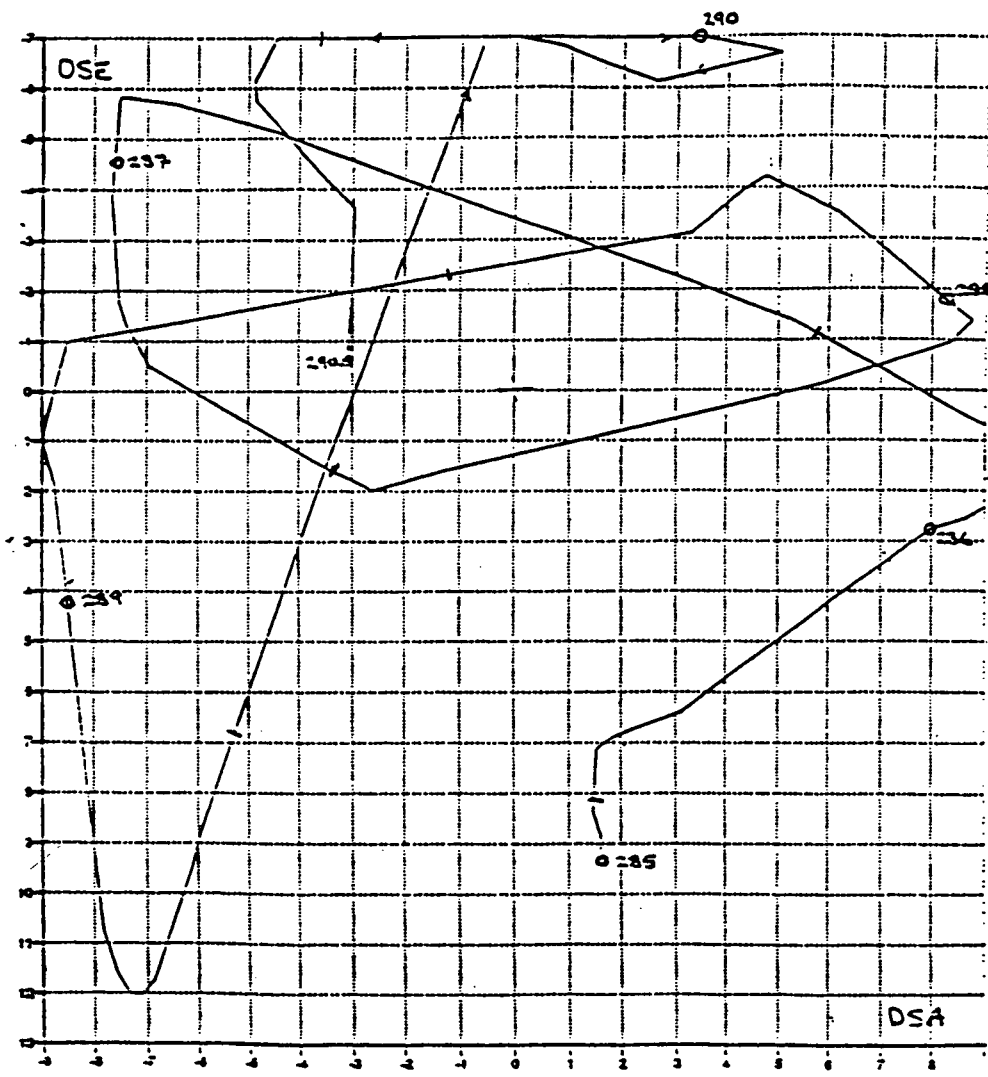

Stick deflection through roll-to-wings-level to the pitchup.

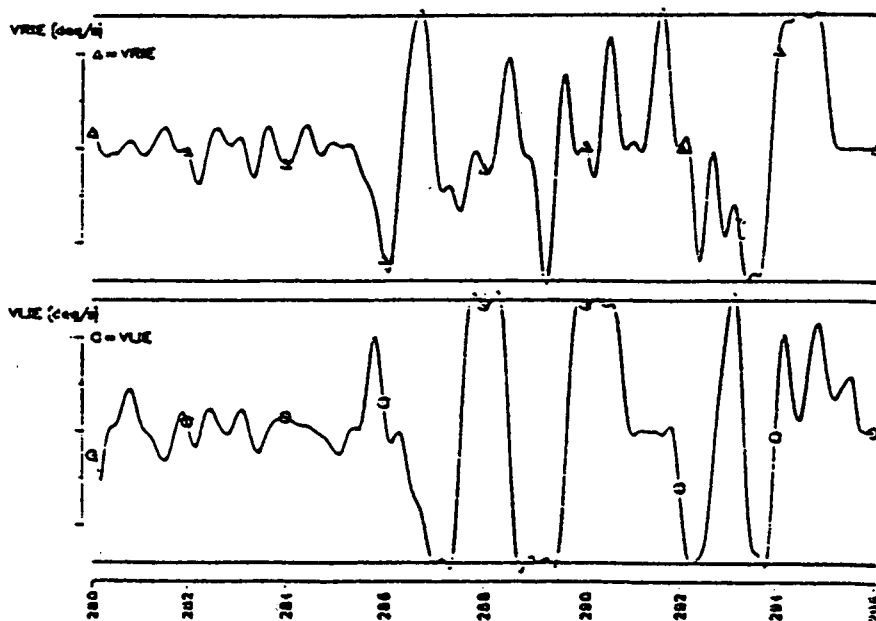

Elevon speed, right (VRIE) and left (VLIE)

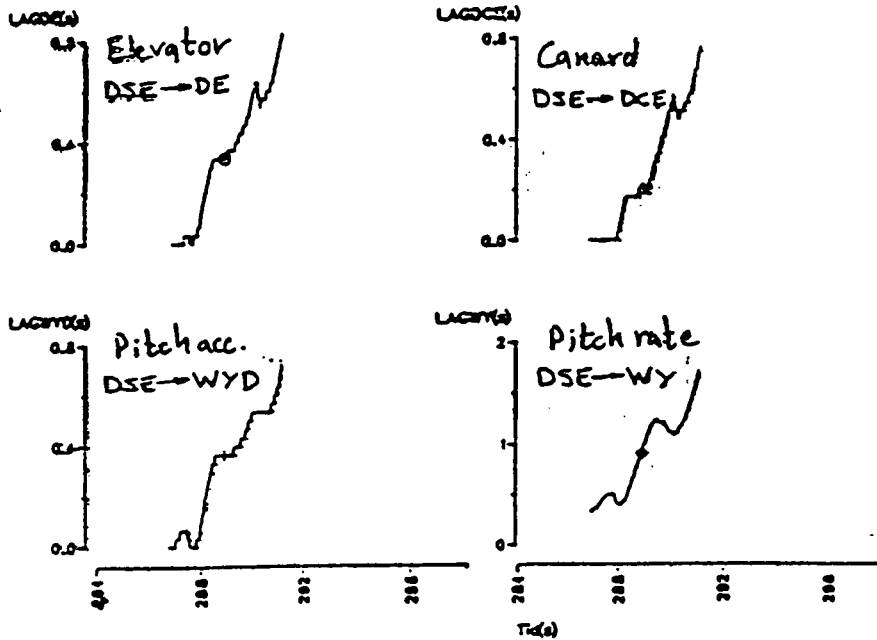

Time-lag in pitch as a function of time.

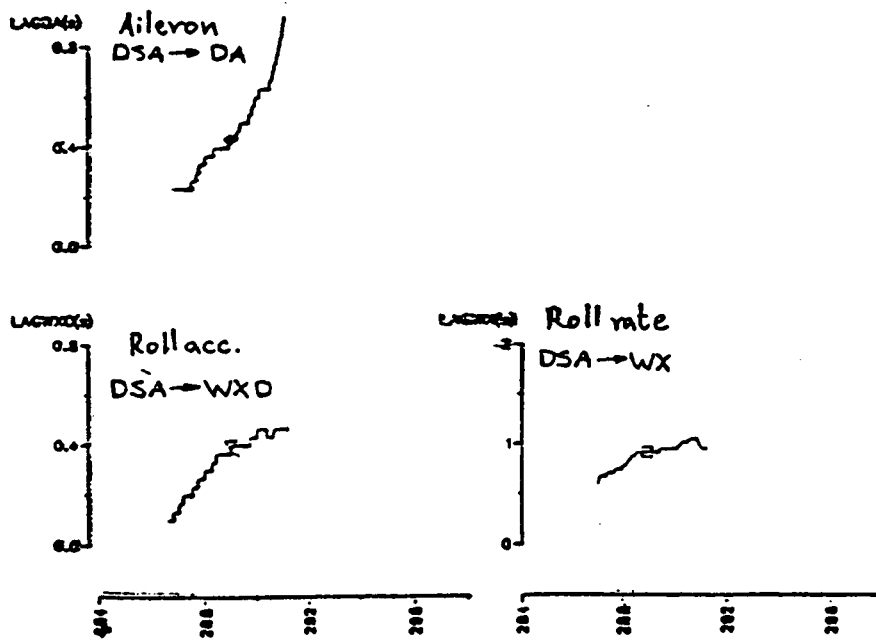

Time-lag in roll as a function of time

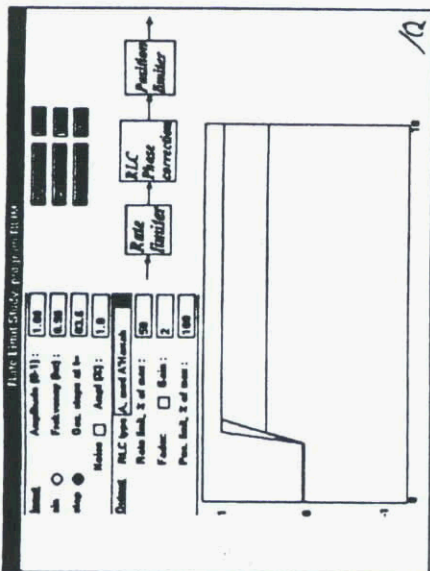

Typ A, stog, utan brus, utan fader

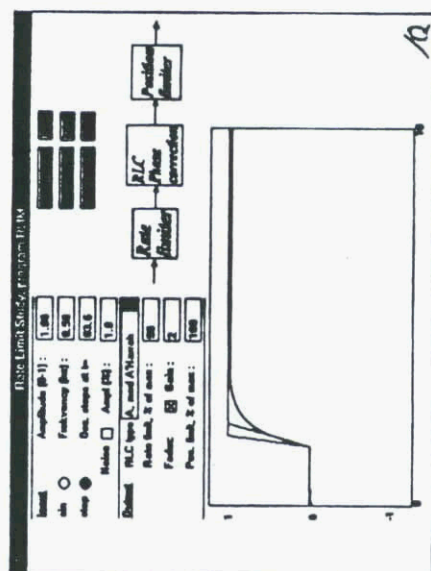

Typ A, stog, utan brus, med fader

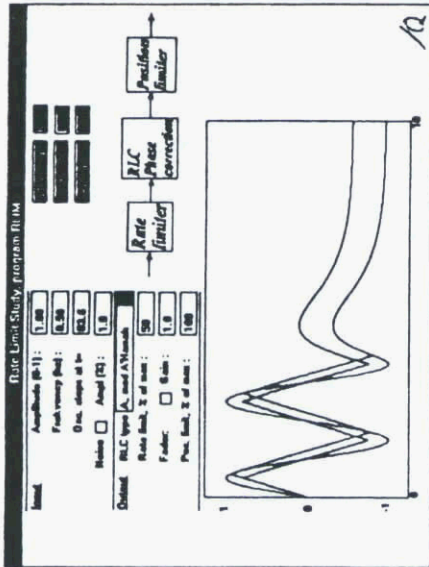

Typ A, utan brus, utan fader

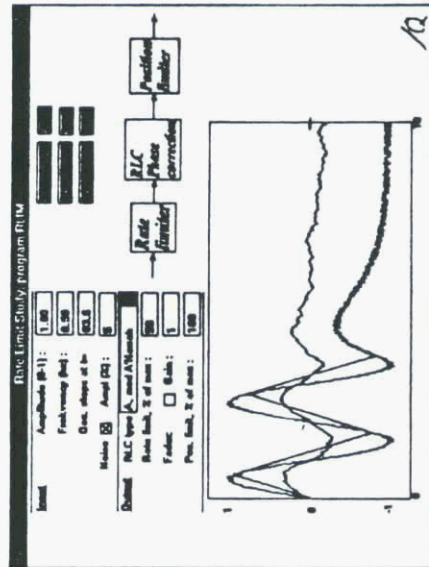

Typ A, med brus, utan fader

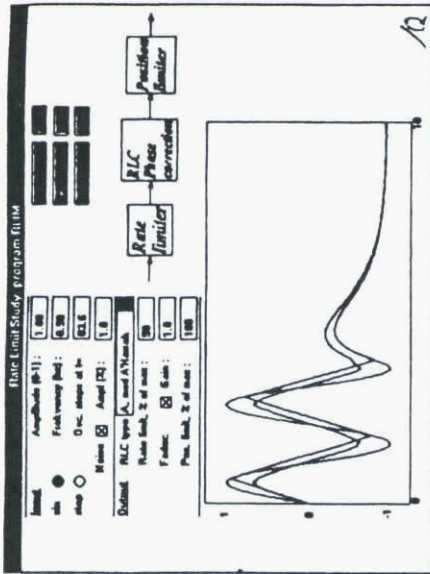

Typ A, med 1% brus, med fader

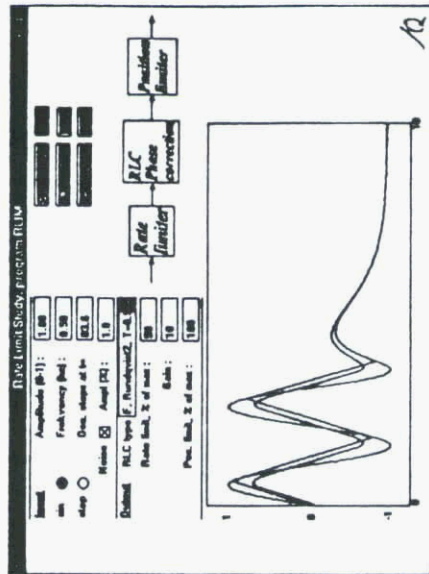

Typ F, med 1% brus

AEROELASTIC PILOT-IN-THE-LOOP OSCILLATIONS

Captain W.J. Norton
US Air Force Officer
9197 Lime Avenue
California City, CA 93505
United States

ABSTRACT

Pilot-induced oscillation (PIO) is an unwanted and inadvertent closed-loop coupling between the pilot and one or more independent response variables of an aircraft. PIO typically results when the pilot attempts to perform a high gain tracking task using the usual cues of acceleration or attitude. Control system and aircraft characteristics within the bandwidth in which the pilot is active can contribute to a coupling between the pilot response and aircraft dynamics. The result is a neutrally damped or undamped out-of-control condition in which the pilot is often making intentional extreme and repetitive inputs in an effort to damp the motion but only serves to enhance it. Pilot-augmented oscillation (PAO) is an unintentional closed-loop coupling which does not involve a tracking task. Another aircraft variable which may lead to PIO or PAO is aeroelastic deformation of the vehicle structure. This elastic response can produce pilot cues or aircraft rigid body motion which can be enhanced when the pilot attempts to damp the oscillation and PIO results. Or, the elastic oscillations alone may lead to PAO. The potential for aeroelastic pilot-in-the-loop coupling is not widely recognized, and this can mean resources expended in ineffectual or non-optimal solutions to the problem until the aeroelastic source is recognized. This paper will characterize the aeroelastic/pilot coupling phenomena without reproducing the fundamental research which has already been published on more general PIO. Examples of aeroelastic PIO and PAO will be provided to illustrate the various ways in which the phenomena can manifest itself, including recent experiences with the C-17A and the V-22. An examination of the potential for predicting this coupling will also be provided. Lastly, recommendations for flight test methodology to uncover and investigate aeroelastic pilot-in-the-loop coupling will be provided.

NOMENCLATURE

AOA	angle of attack
ASE	aeroservoelasticity
CG	center of gravity
EFCS	electronic flight control system
g	acceleration due to gravity
HQDT	handling qualities during tracking
Hz	hertz (cycles/second)
LCO	limit cycle oscillation
PAO	pilot-augmented oscillation
PIO	pilot-induced oscillation
V/STOL	vertical/short takeoff and landing

BACKGROUND

The aeroelastic behavior of an air vehicle can affect its stability and control in ways which are often not fully appreciated. The aeroelastic characteristics are determined by structural inertia, structural stiffness, and airloads. These elastic effects are, most fundamentally, the deformation of lifting surfaces and fuselage or the altering of their incidence. The principle results are a change in trim requirements which may result in maximum trim authority being reached earlier than predicted, a change in lift

distribution and pitching moments, and reduction in control surface effectiveness. One good example of the later phenomenon is the decreases in the rolling moment normally expected of a rigid wing whereby wing torsional deformation produces an effective reduction in the angle of attack (AOA) of the wing-aileron combination. Taken to extremes, this effect can yield an opposite moment than expected of a lateral control input (aileron reversal). Other examples of aeroelasticity affecting stability and control are wing torsion producing a washout or reduction in AOA at the outboard portion of the wing, fuselage bending altering tail incidence, and elevator chordwise distortion (known as rollup). Wing, fuselage, and aileron distortion tends to be destabilizing while tailplane, elevator, and general control surface distortion is usually stabilizing. A potential aeroelastic effect on controllability of a mechanical flight control system is unanticipated loads in the mechanical system (cables, pushrods, etc.) producing uncommanded control surface deflections.

Another source of stability and control problems is the feedback of structural modes of response through the electronic flight control system sensors to the control algorithms. These sensors (normal and lateral accelerometers, pitch, roll and yaw rate gyros, etc.) which are mounted to the structure, will also measure acceleration and angular velocities produced by structural deformations such as fuselage bending and torsion. Control surface rotation due to structural deformation and their elastic modes will also be fed back via surface position sensors. These structural responses can be perceived by the flight computers as uncommanded surface deflections. The aeroelastic signals from the sensors will be fed into the flight control system computer, which will in turn command control surface deflections to counter what it takes to be aircraft rigid body motion or erroneous control surface positions. The phase lag from the sensor to the control surface motion may be such that a sustained motion can result. It is possible for this structural feedback to produce large neutrally damped or even divergent oscillations of the control surface, resulting in overall system instability and the possibility of structural failure. These problems lie in the field of aeroservoelasticity (ASE).

The effects of structural coupling can be reduced by placing the sensors at ideal locations or "sweet spots" within the structure. These are generally locations with the least motion overall, but may be where particular structural modes are least likely to create feedback problems. The point of least angular motion is ideal for a gyro sensor and the point of least linear motion is ideal for an accelerometer. The lower order structural modes generally contain the most energy, produce the least structural deflection, and are the most likely to be within the active bandwidth of the flight control laws and the pilot responsiveness. More typical today, the structural signal is simply filtered at the frequency of concern. Ground vibration tests and ground resonance tests are used to verify the positioning of these structural filters. These tests verify the mandated gain margin to prevent ASE instabilities. However, no such criteria exists to ensure against aeroelastic pilot-in-the-loop instabilities. Analytical and hardware simulators are used to verify that the filters do not adversely degrade handling qualities.

INTRODUCTION

A detailed definition of the fundamental PIO problem will provide the foundation for a more general definition of the aeroelastic pilot-in-the-loop oscillation effects.

PIO Definition

Pilot-induced oscillation is the undesirable and inadvertent closed-loop coupling of the pilot with one or more independent response variables of the aircraft (References 2 and 3). The phenomenon typically manifests itself during a high gain pilot task such as visual tracking. It is characterized by repetitious, and often large control inputs in concert with a zero damped or divergent aircraft resonant oscillation, such as pitch or roll (example response in Figure 1. from Reference 4). The pilot attempts to damp the oscillation but the control inputs act only to sustain or drive the response to greater amplitude because of an unfavorable phase relationship between the input and the aircraft response. Therefore, a PIO

constitutes an out-of-control state and, if allowed to diverge to extreme attitudes and rates, can produce destructive flight loads. The aircraft may otherwise have stable stick-free or stick-fixed dynamics, and perhaps even generally adequate handling qualities at the flight condition.

The high gain visual tracking tasks most commonly associated with PIO include aerial refueling, formation flight, air-to-air tracking, ground gunnery, and approach and landing. Performing these tasks involve acute pilot attention to visual (including displayed information) and vestibular cues, i.e. personally sensed attitude and rates, neuromuscular and proprioceptive dynamics (e.g. seat-of-the-pants). Accelerations as low as 0.01g (Reference 2) can be sensed by pilots and thus contribute to coupling. Exactly how a pilot processes and reacts to these sensory inputs is still not entirely understood, and yet they lie at the heart of the PIO problem. The mere presence of the mass of the pilot's hands on the controls can be destabilizing in some instances (the limb bobweight effect). The mere anthropometric dimensions of the pilot has the effect of alter input gains in a limb bobweight influence. Should the aircraft response to the pilot's input fail to produce the desired result as revealed by the sensory response, the pilot will correct the input as basic vestibular and flying experience dictates. If the correction results in a greater perceived response error, the unstable input-response condition can result. The pilot-dependent nature of PIO makes it somewhat insidious in that one pilot may experience the event where another may not because of individual sensitivity, reactions, experience, and control techniques.

An important example of an independent response variable component of the PIO instability is control system time delay in the affected axes which induces phase lag within the bandwidth of the pilot response. The delay could be the product of feel (i.e. bungee) or control system nonlinearities, computation delays for digital systems, or higher order system dynamics (Reference 3). When the PIO is associated with a rigid body mode of the aircraft (dutch-roll, short period, etc.) as an independent variable, it has been found that a modal damping of 2 percent or less is required for a resonant condition (Reference 3). PIO is also often associated with saturation of the control system, i.e. high rate maximum control inputs or control surface rate-limiting (adding phase lag), and control system nonlinearities. Abrupt control inputs have also been associated with PIO onset (Reference 4). The switch from attitude tracking to pilot-felt acceleration tracking has been observed to be part of PIO initiation (Reference 4). The human dynamics involved with this "switching" is not well understood at this time. Transients due to turbulence, control system activation/deactivation or mode changes, and abrupt trim changes are additional possible contributors.

Aeroelastic Pilot-in-the-Loop Definition

It is essential for the most effective solution to a aeroelastic coupling problem that the source of the instability be properly identified. This is not always readily accomplished because of the complexity of the pilot-vehicle system and the nature of the pilot-in-the-loop phenomena. An aircraft variable which has contributed to such instabilities but one which is not commonly considered is the aeroelastic modes of response of the airframe. These are such deformation modes as wing torsion, fuselage first longitudinal bending, vertical tail pitch, and podded engine yaw. Each mode has an associated frequency, mode shape, and damping; all of which are subject to change as a function of the aerodynamic loads (airloads, air density, shock wave effects). When excited by a maneuver (inertia, airload change) gusts, or internal mechanical impulse, the structure will oscillate at these modal responses at its particular damping rate. Periodic mechanical vibrations of the air vehicle are also present in the system. One or more modes may play in a PIO or PAO event.

AEROELASTIC PIO can be defined as

TYPE I - Aeroelastic structural deformation produces accelerations or attitude changes at the pilot station which results in PIO when the pilot intentionally attempts to counter these dynamics.

TYPE II - Aeroelastic structural deformation produces an aircraft rigid body response which results in PIO when the pilot intentionally attempts to counter these dynamics.

AEROELASTIC PAO can be defined as

Aeroelastic oscillations or mechanical vibrations produces accelerations at the pilot station which the pilot unintentionally couples with, sustaining or enhancing these dynamics.

Examples of these instabilities will be presented in a following section.

Including all of the factors acting in an aeroelastic/pilot coupling event, a block diagram of the system containing these elements would look like Figure 1. Since the practical limit of a manual pilot input bandwidth is about 3 Hz, the structural elastic modes contributing to an aeroelastic PIO would typically be restricted to this level as well. However, there have been examples of PIO in which the pilot response and the PIO resonance did not share the same frequency, especially when the system goes from nonsaturation to saturation (Reference 3). Because PAO is an unintended input created by a physical vibration of the pilot/stick or pilot/throttle systems, frequencies above 3 Hz can come into play. The excited and sensed elastic mode may alter the gain and phase characteristics of the control system such as to allow a PIO to develop at a frequency different from the elastic mode's frequency. While few PIO problems have been rooted in aircraft elastic modes, these sorts of PIOs continue to appear during flight tests and must be understood to be properly dealt with.

One noteworthy source of PIO which has been observed is fuel slosh. This has been encountered on the T-37A, KC-135A, and KC-10, most notably when an attempt was made to damp dutch-roll oscillations using rudder. The momentum affects of the fuel slosh at approximately the same frequency as the dutch-roll motion served to enhance the oscillations to a PIO. Changes in fuel tank baffling cured this problem. This an example of an inertia coupling phenomena that falls between the more classical PIO problem and aeroelastic PIO. A similar instability has resulted from the pendulum motion of sling loads below helicopters and V/STOL aircraft.

EXAMPLES OF AEROELASTIC PIO & PAO

What follows are a few cases of aeroelastic PIO and PAO which were readily uncovered with just a little library research. They illustrate both types of aeroelastic/pilot coupling and just a few of the many conceivable mechanisms for the instability. There have probably been many instances of aeroelastic pilot-in-the-loop instabilities in the history of mechanical flight which either have gone undocumented or were resolved without being identified as such.

YF-12A

The Lockheed YF-12A (Figure 3) experienced a small-amplitude PIO of about 1.0 Hz during the high pilot gain aerial refueling task (Reference 5). The severity of the PIO increased as fuel was on-loaded to maximum capacity. The cause of this anomaly was the first longitudinal fuselage bending mode at approximately 2.5 Hz which produced a small but perceptible vertical acceleration at the pilot station when excited, which the pilot then naturally attempted to damp manually. This fuselage bending was induced by the frequent elevon inputs during refueling which changed the airload distribution on the wings/aft fuselage with respect to the rest of the airframe. The unusually long cantilevered forward fuselage of the aircraft served to amplify the amount of fuselage pitching at the pilot station as a result of the first bending mode. Figure 4 (from Reference 5) illustrates the longitudinal fuselage bending mode shape and shows the cockpit motion that the modes produced. This problem represents a Type I aeroelastic PIO. The PIO was an annoyance only and the pilot was able to avoid reacting to the fuselage

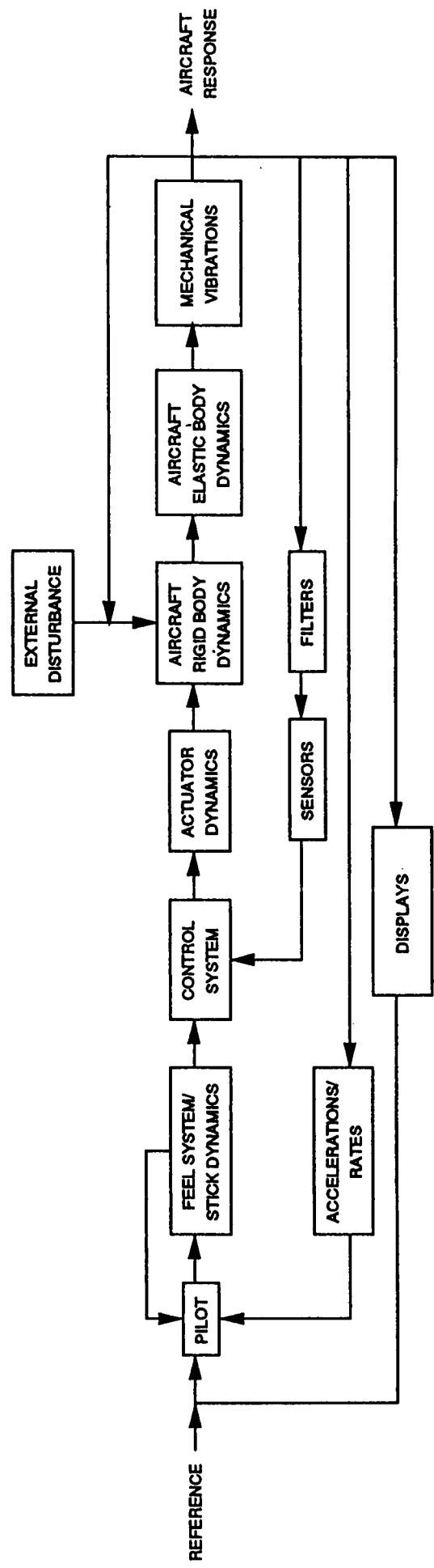

DO DISK THREE/NORTTECH

bending response with sufficient concentration once the dynamics of the problem were understood. It is important to note that the PIO frequency was less than half of the source structural mode. The two frequencies may not be coincident in frequency and this can complicate determining the source of the PIO.

Note in Figure 4 that the positioning of the gyro package and instrumentation (accelerometer) package is optimized to preclude the influence of fuselage elasticity. The gyro package is placed near the point of least rotational acceleration from the mode, and the accelerometers placed at the point of least normal acceleration from the mode. Feedback of signals from either of these packages through a flight control computer would not be expected to produce a PIO or limit cycle response due to structural feedback (the ASE issue). However, it was not sufficient in itself to preclude a PIO problem.

F-111

All models of the F-111 fighter-bomber (Figure 5) have experienced a sustained heavy underwing store oscillation characteristic called limit cycle oscillation (LCO) (Reference 6) at the edges of its flight envelope. Generally associated with high pitch inertia stores and at various wing sweep angles, wing elastic motion at about 2.8 Hz results. For the more common LCO case, antisymmetric wing bending and torsional deformations result in an asymmetric airload distribution which produces an uncommanded rolling moment. In fact, the store oscillation is frequently initiated by an abrupt maneuver, particularly in the lateral axis. When the pilot attempts to arrest the rolling motion manually, the tendency to enter a PIO is very great. The lateral stick movements deflect the outboard roll spoilers on the wings in a sense that enhances the divergent rolling motion. This, then, is an example of Type II aeroelastic PIO since the wing deformation is producing a rigid body roll which leads to PIO when the pilot enters the loop to bring the rolling moment to zero. When the pilot attempted to hold the stick centered after the oscillation was excited, the aircraft rolling motion had a tendency to rock the pilot from side to side, inadvertently commanding additional alternating roll commands. Thus, an aeroelastic PIO became an aeroelastic PAO when the pilot attempted to take himself out of the loop.

Rutan Voyager

The Rutan *Voyager* aircraft (Figure 6) flew around the world non-stop and unrefueled on 14 through 23 December 1986. The aircraft was unconventional in design and construction, and was exceptionally flexible under airloads. Among its many unusual flight characteristics, the plane suffered from what its crew called "pitch porpoising" (Reference 7). The root cause of this porpoising was symmetrical wing bending which could be induced by a vertical wind gust or a sudden longitudinal input from the pilot. Coupling between the wing bending mode and fuselage bending enhanced the wing motion. The event occurred at heavy weights (regardless of cg position) and 82.5 knots, doubling in amplitude each 1.5 cycles. Apart from decelerating, the pilot had to manually damp the pitch oscillations with longitudinal stick inputs, applying forward stick as the nose pitched down, etc. This proved to be a very difficult task and any error would only worsen the situation, adding PIO to what was essentially an incipient flutter mode. Only the development of a special autopilot for the aircraft to actively damp the motion made the aircraft suitable for its mission. This is representative of a Type I aeroelastic PIO with the "wing flapping" producing a pitch acceleration at the pilot station naturally leading to PIO unless the pilot was especially attentive.

Initial plans to decouple the wing and fuselage modes by adding mass to the wing tips on a cantilever beam extending ahead of the tips, effectively reducing the wing bending frequency, were dropped. Instead, bob weights were added in the pitch control system to improve stick dynamics in the necessary bandwidth and to reduce the pilot workload in damping the motion. Even given this, the *Voyager* remained a marginally safe aircraft.

V-22 Osprey

The tilt-rotor V/STOL (vertical/short takeoff and landing) Bell Helicopter Textron V-22 aircraft (Figure 7) suffered a number of pilot-in-the-loop instabilities during its early development which involved aeroelastic modes of the aircraft and digital flight control system characteristics (Reference 8 and 9). The test team encountered a 3.2-Hz PAO above approximately 250 knots (conventional "airplane" mode) in which the pilot/lateral stick system coupled with the antisymmetrical wing fore/aft (chord) bending mode. Later, above 300 knots (airplane mode), a 4.3-Hz PAO was uncovered which involved the coupling of symmetrical wing fore/aft bending with pilot input to the thrust control lever and longitudinal stick. The airframe oscillations caused the pilot's arm to make unintended small, periodic thrust and pitch inputs. This limb bobweight effect permitted PAO involving the pilot input at a frequency which a pilot is normally unable to intentionally command physically. This same instability manifested itself at 3.8 Hz during accelerations and decelerations while carrying a sling load on the aft hook. The difference in oscillation frequency may have been due to an increase in wing modal frequency with a reduction in wing fuel, or the the pendulum motion of the load may have been a primary contributor to the instability. These problems were alleviated with notch filter additions to the flight control laws to attenuate the pilot input in the forward path at the troublesome frequencies. These PAOs were highly pilot-dependent; with one pilot experiencing the instability but another unable to duplicate the instability. This was partially attributed to the varying anthropometric gains of the individual pilots.

An uncomfortable 1.8 Hz vertical bouncing oscillation was experienced at low power settings during approaches to hover. The pilot was coupling with symmetrical wing span-wise (beam) bending which probably had the effect of altering the engine thrust vectors and producing uncommanded variations in descent rate. The pilot response appears to have been an example of Type II aeroelastic PIO, and was resolved with a reduction in feedback gains. Another very unusual V-22 instability occurred on the ground. It involved a 1.4-Hz lateral translation mode of the airframe on its landing gear (helicopter mode), producing a rigid body roll oscillation, which the pilot tended to couple with through stick response. The coupling excited the upper focus roll mode of the aircraft. Although the PIO disappeared when the stick was released, the solution involved additional stick mass balancing in the lateral axis for pilot-in-the-loop inertia. This zero airspeed instability involved elastic response in the sense that the stiffness of the landing gear system (spring rate) combined with the inertia of the airframe determined the frequency of the oscillation. The excitation of the rigid body mode of the system implies that, rather than being an inertia coupling instability, it may have been a Type II aeroelastic PIO.

C-17A Globemaster III

An aeroelastic pilot-augmented oscillation was found to exist on the McDonnell Douglas C-17A (Figure x) during a roll with an abrupt application of lateral stick (Reference x). The coupling produced a pronounced 2.2 hertz roll "ratcheting" oscillation superimposed on the steady-state roll. The sharp aileron and spoiler input excited the wing fundamental antisymmetric bending mode, with heavy outboard engine nacelle pitching motion, which produced an oscillatory lateral acceleration at the pilot station, shaking the pilot-stick limb bobweight system. This caused the pilot to inadvertently command lateral stick inputs which had the effect of sustaining the wing bending and lateral accelerations, especially when the stick was held out of the center detent in the region of high forward path gains. The antisymmetrical bending mode, necessarily containing some torsion because of the wing sweep, would produce a lift distribution proverse to the existing roll during one half of the modal cycle and adverse roll lift during the second half of the cycle. The change in engine thrust vectors resulting from the nacelle pitching and wing deformation may also have contributed to the oscillatory roll response. This resulted was an oscillatory lateral oscillation superimposed on the steady-state rolling moment. The ratcheting was also excited by gusts, and by sideslip maneuvers during which the electronic flight control system (EFCS) commanded aileron to counteract the rolling moment produced by the yaw. In one of the earliest versions of the EFCS software the PAO resulted in a Limit Cycle Oscillation (LCO) with heavy and sustained rolling oscillations which prompted flight termination. The PAO was worse at the high speed and high altitude regions of the flight envelope. The C-17A possesses a relatively high gain control system required for its tactical mission and, combined with the heavy aeroelastic oscillations common

Figure C1 Example Roll Ratcheting

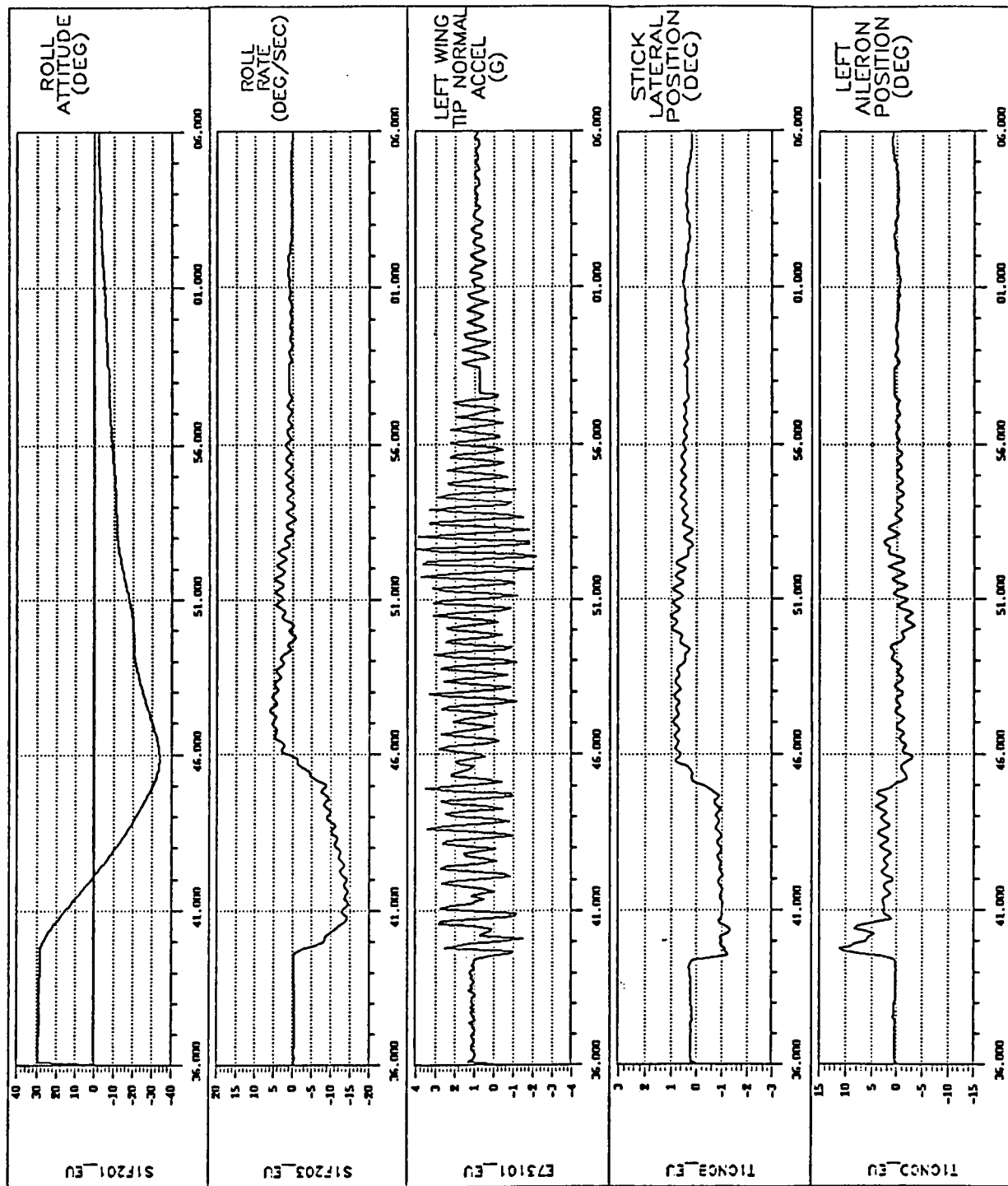

with large transports aircraft, increased the potential for aeroservoelastic and aeroelastic pilot-in-the-loop instabilities.

The roll ratcheting was a very undesirable characteristic which had the potential for causing additional dynamics and controls difficulties during development testing, and produced wing loads in excess of design limits. Later EFCS software versions reduced gains in the forward stick path for the lateral axis, and this eliminated the PAO potential. Further gain changes and digital filtering was planned at the time of writing to further reduce the feedback to an acceptable level. A recovery procedure was briefed for flights intended to investigate the roll ratcheting response or for tests in which there was a high potential for exciting the oscillation. The procedure involved centering the stick after achieving a safe attitude and decelerating. A stick-fixed condition was maintained because experience had shown this to be effective and because the stick pendulum frequency was not known with certainty. The roll ratcheting was also experienced when commanding heading changes with the autopilot (AP) - an ASE instability.

Figure 2 shows the worse case roll ratcheting response. Note the sharp aileron input and the stick maintained out of the center detent during the roll. The motion at the pilot station, the resulting stick motion and aileron response are visible. The ratcheting is evident as the scalloping of the roll rate response trace. Note the large wing tip response at the 2.2-hertz fundamental antisymmetric bending frequency

PREDICTION OF AEROELASTIC PIO & PAO

The prediction of aircraft structural dynamics is based upon well-developed structural and aerodynamic modeling methods combined with sound mathematical solution techniques. However, each component of the analysis incorporates many simplifying assumptions in the reduction of the myriad nonlinearities and to make the solution more tractable and less costly in computer resources. The modeling of unsteady aerodynamics and transonic flow is still limited. And, the prediction of separated flow characteristics is currently not possible. The mechanisms responsible for structural damping is still not entirely understood or fully predictable. The structural resonant frequencies, mode shapes, and particularly attendant acceleration amplitude at specific points within the airframe are not precise. Combining these models with the models of the rigid body aircraft aerodynamics and the control system modeling would produce considerable uncertainties in a simulation incorporating all of these features. Such tests concentrating on areas of suspected PIO/PAO susceptibility may yield useful data. But it would neither guarantee the existence nor nonexistence of any such instability. Of course, refining the analysis variables with the use of flight test data would significantly improve the applicability of the results.

The early prediction of a pilot-in-the-loop oscillation problem can permit corrections to be made to an aircraft prior to initial flight and to avoid testing and production delays, and to combat cost overruns. There are many references which discuss techniques for the analysis of the general PIO instability (Reference 2, 3, 4, 5, and 9), and there is no point in reproducing that work in detail in this paper. These analysis methods may be useful in predicting aeroelastic PIO, and possibly PAO, providing structural response is included in the overall system model. This was attempted in at least one case with limited success (Reference 5). The difficulty comes in the modeling of this response as a simplified control system element in the required notation.

The more common computational analysis methods for predicting potential PIO are explained in Reference 4. They require the modeling of the pilot, usually as a pure gain controller. However, this has occasionally been found to be inadequate simplification. Modeling random turbulence disturbances also commonly uses a model, albeit an empirical one. Smith (Reference 2) states that a resonant pilot-vehicle system, that is one with distinct resonant peaks apparent in transfer function plots (such as in Figure 8, from Reference 3), is a necessary requirement for PIO. He further states, at least for a typical longitudinal

PIO, that the phase margin of the pilot input and pilot-sensed acceleration in the affected axes must be less than zero. The other particulars of these methods will not be reproduced here. The more basic modeling of the pilot/controller system, normally as a simple spring/mass/damper system has more promise for revealing PAO when excited with the predicted aeroelastic or mechanical vibrations the air vehicle is likely to experience. The amplitude of these inputs would then be varied to cover the range of uncertainty in this parameter.

An essential tool for predicting any system instabilities is a simulation. A purely analytical simulation without hardware-in-the-loop or pilot-in-the-loop would require models of system nonlinearities and modeling of the pilot neuromuscular dynamics (a very nonlinear system in itself), in addition to the basic aircraft rigid body dynamics, which add considerable uncertainty to the results. Such simulations are typically done, however, to provide initial insight into potential PIO instabilities. The use of man-in-the-loop ground-based simulators, particularly fixed-based simulators, has occasionally been able to identify PIO instabilities which later occurred in flight or reproduced those which have occurred (Reference 2). The validity of such a test is greatly enhanced in the actual control system flight hardware is included. Oscillation the motion-based simulator in the most likely axes and at possible amplitudes can go a long way toward uncovering PAO. The difficulty comes in the limited frequency response of many such simulators. An electromechanical shaker attached to the controller, with the pilot's limb physically present or simulated, may also provide useful data.

The aircraft model in the simulations should include estimated structural dynamics to provide an initial look at any potential ASE instabilities. These estimated dynamics are in simplified equation forms which predict the displacement rates at the control system package location and possibly control surface position feedbacks resulting from structural deformation. This simulation, however, will not demonstrate the existence or nonexistence of aeroelastic PIO unless the aerodynamic effects of structural elasticity and the accelerations at the pilot station from these deformations are modeled. This could be done in the same manner as for the sensor package for the pilot station response, but has not or is seldom done because the prediction of these effects would be so simplified to permit a real-time simulation that the nuances which play in a PIO event would most likely be lost. A real-time simulation including any reasonable estimation of non-rigid aerodynamics is probably not possible with the current computer and mathematical tools. Inflight simulators have been very helpful in uncovering pilot-in-the-loop instabilities (Reference 4), but the dissimilar aircraft makes it unsuitable for revealing aeroelastic PIO susceptibility.

ALLEVIATION TECHNIQUES

A flight controls engineer would likely assume a strictly control system dependent instability when initially seeking the solution to a PIO/PAO. The general resolution would then be software changes, probably in the form of notch or roll-off filters, or to alleviate system nonlinearities in the bandwidth in which the instability occurs. This can be a very lengthy process of code changes, digital modeling, and simulator tests before the new software is available for flight. The process may require several months, and the new control laws may not produce overall handling qualities as desirable as those preceding the change.

Three basic methods of preventing basic PIO exist, and they hold equally promise for preventing PAO. The first and most common method is to attenuate the pilot input in the bandwidth in which the difficulties occur. A filter in the appropriate stick input channel is commonly used today for digital flight control systems, with a mechanical stick damper, perhaps a viscous damper, used for the non-electrical mechanical effect. This is the "inelegant" solution in that any gain change within the 0 to 3-Hz bandwidth has the potential for degrading general aircraft responsiveness. The second method, when possible without producing additional problems, is to attenuate the feedback signal (in a fly-by-wire system) which is playing a dominant role in creating the instability. The later technique assumes that sufficient test data have been collected to isolate the troublesome feedback channel. If a prior

consideration is given to all possible sources of troublesome feedbacks, including aeroelastic, then the precise mechanism for the anomaly can be determined. Identifying the mechanism can assist in isolating the source to a particular transducer. This is critical in optimizing a solution which will not adversely impact desirable system dynamics. The third method is to eliminate control system phase lags (Reference 2) and nonlinearities. This could involve considerable system optimization to, again, avoid undesirable handling qualities. All system changes must be checked in flight for full validation. All of these solutions presume that it is impractical to make major changes which would change the rigid dynamics of the aircraft. The rigid body modes are determined by the moments of inertia of the vehicles and the aerodynamics (such as the positioning of the wing) at the particular flight condition, and so are difficult and expensive to alter.

Unfortunately, eliminating a Type I aeroelastic PIO at the root cause would mean shifting a structural resonant frequency of the resultant amplitude of structural deformation to prevent coupling. This means a structural change to the air vehicle which is considerably more expensive in resources than a control system change. As an example, it could consist of stiffening a major portion of the airframe. This would entail considerable manufacturing drawing and tooling changes and reanalysis of a portion of the flight loads and structural dynamics. Repeating a portion of the loads and flutter flight testing, and even some of the attendant ground tests, may also be required. The only cost-effective solution would be changes to the control systems as described previously. Eliminating a Type II aeroelastic PIO would be equally difficult, requiring the structural mode changes just discussed or a rigid body aircraft mode change to decouple the response. The rigid body response can be automatically damped with an electronic stability augmentation system or similar function of an overall fly-by-wire system. This should prevent pilot coupling. So, in the end, a control system change is the more likely solution for aeroelastic PIO and PAO. However, recognizing the true source of the instability would provide clues to a solution much easier to implement or one with less adverse impact on the overall system dynamics and aircraft flying qualities.

For a mechanical control system, or electrical systems with mechanical controllers, the addition of an artificial feel system or modifications to an existing feel system can reduce PIO susceptibility. This can take several forms, using one or more of three basic elements (Reference 10). The viscous damper already introduced provides higher stick forces proportional to the rate of stick deflection. A bellows gives a spring gradient that is a function of airspeed and altitude and is essentially a mechanical gain changer. The bobweight will increase stick force per g, and is essentially a mechanical feedback of pilot-applied forces. All of these elements, when properly applied to a control axes affecting PIO, have seen various level of success. However, such measures should be taken with care because of the potential for destabilizing influences beyond the PIO condition, largely because of nonlinearities added to the system, and instances wherein the feel system itself was at the root of a PIO (Reference 9). Similarly, stick friction, break-out forces, preloads, and deadbands or hysteresis also have the potential for either exacerbating or reducing the PIO susceptibility

TESTING METHODOLOGY

Inter-Discipline Communication

The structural dynamics and flight controls members of the flight test team must maintain a close line of communication between each other. Aside from potential aeroelastic/pilot coupling, aeroservoelastic concerns demand this sort of interaction as well. When a pilot-in-the-loop oscillation incident does occur, the structural dynamics team can assist in identifying any potential aeroelastic contribution by comparing the oscillation frequency with structural modes isolated in ground vibration and flight flutter testing. If an aeroelastic contribution to the instability appears to be possible, the structures team can perform analysis or recommend data channels for use in controls analysis to verify this contribution. If the aircraft is not adequately instrumented to verify an aeroelastic contribution to the oscillation, the structures team can recommend transducer installations which will assist in the investigation.

Testing Techniques

The fundamental handling qualities test methods are as suitable for revealing aeroelastic pilot-in-the-loop oscillation susceptibility as they are for other PIO tendencies. PAO would most likely also be uncovered as a consequence. These methods typically consist of performing high gain handling qualities during tracking (HQDT) tasks such as air-to-air tracking. Other basic stability and control tests such as abrupt pull-ups and push-overs or sideslips with an attitude capture on return to steady level flight have a higher potential for exciting structural elastic modes which could contribute to a PIO event. However, such maneuvers are seldom performed during HQDT. The sharp manual control inputs common of flight flutter testing (Reference 1) will produce the highest manually-induced elastic response and, although also not normally concurrent with a high gain pilot task, might uncover any inherent aeroelastic/pilot resonance. An opportune gust or the inertia effects of stores release also has the potential for producing the elastic response that results in an instability. Thus, the potential exists for an aeroelastic PIO to reveal itself during any portion of the early development flight testing. Therefore, the normal envelope expansion testing should consist of concurrent structural dynamic and flying qualities testing in the normal build-up fashion with basic tasks performed as early in the test program as reasonable. The early look at operationally realistic mission tasks which has become common in military flight test efforts may also provide insight in this regard.

Because PIO/PAO susceptibility may be strongly dependent on individual pilot sensitivities and reactions, a single Cooper-Harper rating (Reference 10) among a sampling of pilots indicating poor handling qualities should not be dismissed as anomalous. The damping of the basic rigid body modes of the aircraft should be tracked during the build-up and care taken when they approach the 2 percent criteria mentioned earlier. The frequencies of structural modes should be tracked in concert with the rigid body modes during the build-up to provide warning of the potential for the coupling of these modes. This requires the close association of the flying qualities and structural dynamics test engineers. Tests should, of course, include failure cases with stability augmentation systems off (where practical), reversion to mechanical systems, and other such conditions to ensure PIO-free control in these states. Such systems have the potential for artificially damping an elastic mode when active, so an aeroelastic pilot-in-the-loop oscillation may develop when they are turned off.

Recovery Techniques

The normal PIO recovery procedures, once the pilot or test team recognizes the event as such, is to either:

1. *Neutralize the controls and hold fixed until the dynamics die-out, while decelerating;*
- or
2. *Release the controls to remove the pilot from the loop, while decelerating.*

The concurrent deceleration out of the test condition is best achieved by only pulling the throttles back but may be enhanced with a pull-up. The latter technique may aggravate the aeroelastic component of the PIO, so it should be used judiciously. The choice of recovery techniques would be based upon aircraft, or the failure of one technique to produce the recovery expeditiously. Either method should be suitable for an aeroelastic PIO or PAO.

The F-111 aeroelastic PIO discussed previously illustrates one case in which the recovery procedure proved to be critical. Recall that when the pilot attempted to hold the stick centered during the recovery, the aircraft rolling motion had a tendency to rock the pilot from side to side, inadvertently commanding additional alternating roll commands. In the worst conditions, when the pilot had released the stick, the light lateral stick damping inherent in the design had permitted the pendulum mode of the stick to couple with the rolling inertia produced by the LCO to again create an unstable response. In such a stick-free

situation, the stick had been known to move on its own laterally from stop-to-stop, again producing uncommanded bank-to-bank roll. Recovery by centering the stick and decelerating out of the condition proved to be safe and effective. However, some exciting rides were experienced.

Instrumentation

A basic error which is often made when performing flying qualities tests is to limit the instrumentation to parameters directly associated with the control system and rigid body response. Other parameters must be included to allow for analysis of unexpected events such as ASE anomalies and PIO, including aeroelastic PIO and PAO. The following list is an example of the instrumentation which should be included from the start, or added once a problem occurs which requires investigation. Derived parameters for these basic measurands are not included in the list. Additional useful information on required instrumentation can be found in Reference 9.

Basic control system instrumentation:

- pilot inputs (control forces and deflections)
- control surface deflections
- sensor output (gyros and accelerometers)
- primary system outputs
- primary system feedbacks
- mechanical systems responses

Basic rigid body dynamics instrumentation:

- three-axes cg accelerations
- three-axes cg angular rates
- three-axes pilot station accelerations

Basic structural dynamics instrumentation:

- fuselage bending and torsion
- wing surface bending and torsion
- tail surfaces bending and torsion

The structures parameters could be derived from accelerometers at the extreme of the surfaces or properly located and oriented strain gages. The modal data would need to be interpreted by reference to ground vibration or flight flutter test data.

CONCLUSION

The effects of aeroelastic influences on aircraft controllability are frequently overlooked when attempting to resolve a problem uncovered in flight test. This may be particularly true of pilot-induced oscillations. The work already undertaken to predict PIO will assist in the prediction of aeroelastic PIO, but must be combined with adequate pilot and structural models, both of which greatly increase the uncertainty in the results. Simulations and the inclusion of flight test results should enhance the applicability of the results, but the prediction of aeroelastic PIO or PAO remains a very uncertain undertaking. During flight testing, communication between the structural dynamicists and the flight controls teams must be maintained to deal with combined phenomena such as aeroelastic PIO. Likewise, both structural and controls parameters must be included in a flight test instrumentation suite to provide the data required to deal with such combined effects. Luckily, the time-worn envelope expansion and suitability test techniques and PIO recovery procedures are sufficient for an aeroelastic/pilot coupling instability. Failure to recognize the aeroelastic source for a pilot-in-the-loop instability may delay the resolution to the problem and lead to time-consuming and expensive solutions which adversely effects desirable system dynamics.

(NOTE: This paper is an expansion of an earlier work on the subject of aeroelastic/pilot coupling presented in Reference 13.)

REFERENCES

1. Norton, William J., Captain, USAF, Structures Flight Test Handbook, AFFTC-TIH-90-001, Air Force Flight Test Center, Edwards AFB, California, November 1990.
2. Smith, Ralph H., A Theory for Longitudinal Short-Period Pilot Induced Oscillations, AFFDL-TR-77-57, Air Force Flight Dynamics Laboratory, Wright-Patterson AFB, Ohio, June 1977.
3. Smith, Ralph H., Notes on Lateral-Directional Pilot Induced Oscillations, AFWAL-TR-81-3090, Air Force Flight Dynamics Laboratory, Wright Patterson AFB, Ohio, March 1982.
4. Bjorkman, Eileen A, Captain, USAF, Flight Test Evaluation of Techniques to Predict Longitudinal Pilot Induced Oscillations, AFIT/GAE/AA/86J-1, Air Force Institute of Technology, Wright-Patterson AFB, Ohio, December 1986.
5. Smith, John W. and Berry, Donald T., Analysis of Longitudinal Pilot-Induced Oscillation Tendencies of the YF-12 Aircraft, NASA TN-D-7980, February 1975.
6. Norton, William J., Captain, USAF, "Limit Cycle Oscillation and Flight Flutter Testing," presented in the Society of Flight Test Engineers 21st Annual Symposium Proceedings, 1990.
7. Yeager, Jeana, Rutan, Dick and Patton, Phil, Voyager, Alfred A. Knopf, Inc., New York, 1987.
8. Yen, Jing G., "Osprey Pilot-in-the-Loop Aeroelastic Stability," Bell Helicopter Textron, Inc., 1991.
9. Lunn, Kenn, Dunford, Philip J. and Sullivan, Pat, "V-22 Tiltrotor Development & Flight Characteristics," presented in the Society of Flight Test Engineers 23rd Annual Symposium Proceedings, 1992.
10. Norton, William J., Captain, USAF, C-17A Flutter Flight Testing, AFFTC-TR-93-13, Air Force Flight Test Center, Edwards AFB, California, October 1993.
11. Ashkenas, Irving L., Jex, Henry R. and McRuer, Duane T., Pilot-Induced Oscillations: Their Cause and Analysis, NOR-64-143, Northrop Corporation, 20 June 1964.
12. Flying Qualities Theory and Flight Test Techniques, Chapter 14, "Analysis and Testing of Aircraft Feedback Augmentation Flight Control Systems," USAF Test Pilot School, Smolka, James W., Captain, USAF, 21 March 1983.
13. Norton, William J., Captain, USAF, "Aeroelastic Pilot-Induced Oscillation," presented in the Society of Flight Test Engineers 23rd Annual Symposium Proceedings, 1992.

Handling Qualities Analysis on Rate Limiting Elements in Flight Control Systems

Dietrich Hanke

Deutsche Forschungsanstalt für
Luft- und Raumfahrt e.V.
(DLR)
Institut für Flugmechanik
D - 38108 Braunschweig
Germany

1. SUMMARY

Rate saturation conditions caused by rate limiting elements (RLE's) in flight control systems can contribute to severe pilot induced oscillation. In order to gain more theoretical insight in this problem the paper deals with the development of rate limiter describing functions in order to establish a theoretical basis for open and closed loop handling qualities analysis in the frequency domain. Although rate limitation produces nonlinear system behaviour it could be shown that rate limiter describing functions could be applied to existing methods used in handling qualities analysis of pilot/ aircraft systems.

A new handling quality parameter, **the rate limiter onset frequency**, is defined as a measure of input amplitude and frequency. Here the onset frequency in reference to the system bandwidth could be a suitable parameter in defining handling qualities boundaries for flight control systems with RLE's.

The response in amplitude and phase is presented for different types of input signals such as triangle and sinusoidal oscillations. Rate limiter cascading is considered too.

Further, the suitability of various existing handling quality criteria are compared with the RLE results especially with respect to

PIO. Finally the improvements in system behaviour by applying an alternate control scheme (ACS), as proposed by A'Harrah, will be discussed.

2. INTRODUCTION

Rate saturation conditions in flight control systems are well known as an element which can contribute to severe pilot induced oscillation (PIO). Recently, the problem of rate saturation caused by rate limiting elements (RLE) in flight control systems has been revived due to the proposal to overcome rate saturation produced handling problems by using an alternate control scheme (ACS) providing that the rate of the RLE has the same sign as the commanded rate so that the input and output signals are in phase [1].

Due to this proposal flight tests have been carried out at DLR [2] and Calspan [3] in order to evaluate both the ACS-algorithm and the expected handling quality improvements.

The intention of this investigation is to describe the dynamic behaviour of rate limiting elements in the frequency domain through describing functions in order to provide the basis for both the pilot/ aircraft system analysis and the definition of parameters which will influence handling qualities.

Although RLE's cause nonlinear system behaviour it will be shown in this investigation that linear methods could also be used when RLE's are active in the flight control path. Further it will be shown that existing methods used for handling qualities analysis on pilot/aircraft systems in the frequency domain such as open and closed loop approaches are also applicable [4].

3. RATE LIMITER DESCRIBING FUNCTION FOR TRIANGLE TYPE INPUT SIGNAL

Assuming that the RLE will be excited by a triangle type input (rate limited input) then the output signal is only affected by the RLE if the input rate is higher than the limited rate of the RLE. The time response of both the input and the output signal in the steady state oscillation condition is shown in figure 1.

From this figure the describing function of the nonlinear rate limiting element as a function of input amplitude and frequency can be derived for the amplitude

$$A = X_o/X_i = X_o^o t_o / X_i^o t_i$$

with

$$t_o = t_i$$

and

$$k = X_o^o / X_i^o$$

it follows

$$A = k$$

and for the phase

$$\phi = - \omega_i T_D$$

with

$$\omega_i = \pi/2 t_i$$

it follows

$$\phi = - \pi/2 (1 - k)$$

$$0 \leq k \leq 1$$

By defining the ratio of the rate limiter rate to the input signal rate as k both the amplitude and the phase angle will be linear functions of k .

An important parameter is the frequency at which the RLE will become active. This frequency is called the

RLE onset frequency,

$$\omega_{onset}$$

The onset frequency can be calculated as

$$X_i^o = X_o^o$$

$$X_i^o = X_i \omega_i 2 / \pi$$

$$\omega_{onset} = X_o^o / X_i \pi/2$$

or

$$\omega_{onset} = k \omega_i$$

It turns out that this frequency is proportional to the RLE rate and inverse proportional to the input amplitude.

The frequency response of the triangle type excited RLE is shown as bode plot in figure 2 indicating that there is no amplitude or phase delay as long as the RLE will not onset. After onset the amplitude decreases with -20dB/decade and the phase shows an initial steep gradient with a final value of -90 degrees at high frequencies.

The frequency response for different input amplitudes is characterized by different onset frequencies. That means that the frequency response curve is shifted to the left along the frequency axis in case of increasing amplitudes and vice versa.

For simplification the frequency could be normalized by the onset frequency so that the frequency response is valid for all input amplitudes. The RLE onsets then at the normalized frequency of one.

The time delay which is often used instead of phase delay can be calculated as

$$T_D = t_i (1 - k)$$

The time delay has a maximum at a specific rate ratio or frequency.

The maximum time delay occurs exactly at a rate ratio of

$$k = 0.5$$

or at

$$\omega = 2 \omega_{\text{onset}}$$

The time delay as a function of input amplitude and frequency is illustrated in figure 3. From this figure it could be derived that by doubling the input amplitude the onset frequency will be halved and the maximum time delay will also be doubled. Large amplitudes provide a sharp maximum and small amplitudes a flat maximum of time delay.

4. RATE LIMITER DESCRIBING FUNCTION FOR SINUSOIDAL TYPE INPUT SIGNAL

Figure 4 indicates the time response of a fully active RLE in the steady state oscillation condition excited by a sinusoidal input signal.

The situation for different rate ratios of RLE rate and input rate is represented in figure 5.

It is seen that the rate limiter onsets if the rate limitation is equal to or lower than the maximum rate of the sinusoidal input. After that the input signal rate varies with the cosine so that there are conditions where the output signal will 'meet' the input signal at a rate which is lower than the RLE rate so that the output signal will follow the input signal (the RLE remains deactivated).

Due to this fact there are conditions where the RLE is only partly active. These conditions are given in the regions I and II as shown in figure 5. Region III is the area

where the input signal rate is always greater than the RLE rate, so the RLE will be active at all times.

Due to these nonlinearities it is necessary to use for each set of conditions different RLE describing functions.

In region I the output of the RLE will meet the input signal before the maximum of the input signal is reached. After the 'meeting point' the output will follow the input signal. Because the amplitude and phase are defined in reference to the maximum amplitude and the change of sign of the input signal we can conclude that there is no RLE produced amplitude and phase delay in region I.

The condition that the output signal exactly meets the input signal at its maximum is given for

$$k = X_o / X_{\text{imax}} = 0.725$$

or with

$$\omega_{\text{onset}} = \omega_i k \pi / 2$$

at

$$\omega_i = 1.38 \omega_{\text{onset}}$$

Because amplitude and phase delay will occur only for RLE rates lower than 0.725 (Region II) this frequency is called

the effective RLE onset frequency

$$\omega_{\text{onset effective}}$$

The amplitude and phase values in region II can be calculated by solving the equation

$$f(t) = \sin(t) - \cos(t_o) (t - t_o) - \sin(t_o) = 0$$

with $\cos(t_o) = k$

in order to get the point of intersection of the RLE rate with the input sine signal. The equation could not be solved explicitly. This was done by using the Newton approximation method.

The amplitude is then approximated by using a quadratic function of k and the

phase by using a linear function of k as for

Region I

$$1 \geq k \geq 0.725$$

$$A = 0$$

$$\phi = 0$$

Region II

$$0.725 > k > 0.537$$

$$A = 1 - 4.51 (0.725 - k)^2$$

$$\phi = - 173 (k - 0.537) - 32.5$$

Region III

$$k \leq 0.537$$

$$A = k \pi/2$$

$$\phi = - \arccos (k \pi/2)$$

For

$$k \leq 0.537$$

or for

$$\omega \geq 1.86 \omega_{\text{onset}}$$

the condition is given where the input rate is always higher than the RLE rate so that the RLE is active all the time.

This behaviour is illustrated in the bode plot in figure 6.

The general results drawn from the triangle type excited RLE are also valid for sinusoidal inputs.

The explicit time delay can be calculated by using the relationship

$$\phi = \omega_i T_D$$

For region III the time delay is given by

$$T_D = - \arccos(k \pi/2) / \omega_i$$

The amplitude and phase response is very similar to that of the triangle type input but the RLE onset is shifted by the factor of 1.38 to higher frequencies.

Figure 7 gives the phase delay as a function of input amplitude and frequency. Illustrated are curves of constant phase delay produced by the RLE as the theoretical onset (dotted curve), the effective onset (bold solid curve) and constant phase curves of different amount of phase delay. By changing the RLE rate the whole set of curves will be shifted along the frequency axis.

5. CASCADED RATE LIMITER DESCRIBING FUNCTION

In flight control systems often additional signal rate limitation is implemented in order to avoid actuator rate saturation caused by large pilot command inputs in combination with large augmentation of system commands so that several RLE's could be active in the flight control path.

This situation where several RLE's are in series is identified as **cascaded rate limitation**.

The cascaded rate limitation situation is exemplified in figure 8.

The total frequency response of cascaded rate limitation is given by multiplying the transfer function blocks as it is valid for linear transfer functions but interchanging the transfer blocks is not allowed for nonlinear systems. As long as the frequency is lower than the onset frequency of the relevant RLE the transfer function will have zero dB in amplitude and zero degree in phase.

Assuming that the rate limitations of the different RLE's are different it is obvious that with increasing input frequency or amplitude the RLE with the lowest rate

value will be active first (lowest onset frequency) because the input signal will pass all RLE's with higher rates.

If the input frequency is further increased the other RLE's become active (onset) if their onset frequencies are reached. The amplitude and phase between two RLE's will then be fixed by their rate ratio. These values remain constant and independent of the input frequency and amplitude.

In cases where the lowest RLE is in front of the RLE's with higher rate settings they will never be active because the lowest RLE output rate is always lower than that of the others.

The frequency response of a cascaded rate limiter situation with three RLE's is shown in figure 9.

This figure illustrates an example for three RLE's in series showing that each rate limiter will be active (onset) one after the other and each contribute in amplitude and phase with a constant value which is given by the value at the onset frequency. The amplitude slope remains also in the cascaded situation - 20 dB/ decade.

It is clearly seen that cascaded rate limitation degrades the total frequency response tremendously. Important for the total behaviour is the ratio of the onset frequencies of the different RLE's.

Figure 10 indicates the phase response in case of similar sinusoidal type input showing the behaviour where different RLE's became active at their individual effective onset frequencies.

As far as handling qualities are concerned it can be concluded from this figure that implementing cascaded rate limitation in flight control systems makes little sense because the frequency response will additionally be degraded.

6. COMPARISON OF THEORETICAL RESULTS WITH REAL MEASUREMENTS

Apart from signal rate limitation realized in

the flight control computer systems the actuator generally became rate saturated if larger amplitudes were commanded.

As an example figure 11 shows the frequency response of an electro-hydraulic actuator of DLR's flying simulator ATTAS which is used for direct lift control excited with increasing amplitudes. It is seen that for a commanded amplitude of 20% of the maximum stroke the actuator is rate saturated. Further it is seen that the onset frequency is reduced with increasing amplitude and that the amplitude slope of - 20 dB/ decade and the steep phase delay is evident as it is theoretically described.

In that case where the actuator input signal is electronically rate limited such that the actuator itself did not become rate saturated the frequency response results in the linear summation of both the frequency response of the actuator and the rate limiter amplitude and phase as exemplified in figure 12.

7. INFLUENCE OF RATE LIMITATION ON PILOT/ AIRCRAFT SYSTEM HANDLING QUALITIES

A typical pitch axis closed loop control situation as it is used for pilot/ aircraft handling quality analysis is shown in figure 13.

Handling quality criteria or parameters are based on closed loop parameters e.g. the Neal-Smith criterion [5] with pilot lead/lag phase and resonance of the closed loop system or on open loop parameters like bandwidth , phase delay and phase rate [6,7].

The rate limiter describing function provides the base for investigating the influence of rate limitation on closed or open loop systems very easily by using the established handling quality analysis methods.

7.1 The rate limiter onset frequency

It is obvious that the **rate limiter onset frequency** as a function of input amplitude is the key parameter with respect to aircraft handling qualities because for the pilot the dynamic behaviour of the aircraft will change dramatically at this frequency.

If the pilot is not able to adapt to the sudden dynamic change pilot induced oscillation can occur and control could be lost.

Increasing the input amplitude will drive the onset frequency to lower frequency values as it is shown in figure 7.

Existing handling quality criteria imply linear response of the controlled plant and all handling quality parameters are therefore only valid for these conditions. For nonlinear behaviour as it is given when rate limitation becomes active the handling quality criteria should be adapted. The rate limitation problem could be tackled by defining **flying qualities** as a function of **input amplitude** represented by **RLE-onset frequency**.

As it is exemplified in figure 14 linear flying quality criteria are valid in the region below the RLE onset boundary. Above the boundary RLE behaviour has to be considered for pilot/ aircraft stability analysis. Further this representation could be used to define the allowed distance of the RLE onset frequency relative to the task bandwidth for the linear system (**RLE-onset margin**).

For instance the **task dependent amplitudes** have to be defined to avoid at the bandwidth frequency ω_{BW} the RLE onset. Because flying qualities are inherently connected to flight safety the probability of exceeding the defined amplitude could also be an adequate approach to define the allowed input amplitudes. In order to provide an onset margin the RLE-onset frequency should

have a suitable distance from the bandwidth frequency for level 1 flying qualities.

In cases where higher amplitudes are required from both the pilot and/ or the flight control system as normally used and the RLE becomes active, the influence of the RLE should be such that the flying qualities do not become worse than level 2 but with double amplitude by no means should 'jump' to level 3 or create pilot induced oscillation as it is required in the MIL-F-8785 specifications.

Additional analysis, simulation and flight tests have to be done to provide the data to be able to define RLE- onset margins or to show that in a rate limited condition the bandwidth reduction is acceptable.

7.2 Open/ closed loop handling quality parameters

The influence of RLE on handling qualities could be studied by comparing the effects on existing handling qualities criteria.

In figure 15 RLE produced time delay is compared with the bandwidth criterion [6] showing that the boundaries from level 1 to 3 are exceeded in case of increased amplitudes. Assumed is an aircraft with 0.25 s time delay where a RLE is added. The behaviour is quite nonlinear depending on both amplitude and frequency.

Further, the influence of RLE on open and closed loop parameters could also be demonstrated by using the Nichols plot [5]. Figure 16 exemplifies how the phase and amplitude margin of the open loop system and how the closed loop bandwidth and resonance are effected by a RLE.

Curve A represents a typical aircraft short period response with a pilot modelled by a pure gain and a time delay of .3 s providing a closed loop bandwidth of about 1.5 rad/s.

Curve B shows how curve A is influenced by the RLE which becomes active at the onset frequency of $\omega_{onset} = 1$.

Further it can be derived that the phase/amplitude slope remains nearly unchanged but that the bandwidth defined by phase and gain margin is heavily reduced. If the pilot would increase his gain in order to stay with the needed bandwidth of 1.5 rad/s (curve C) by applying e.g. double amplitude the onset frequency shifts to .5 rad/s and he would get 8 dB resonance. Finally with higher gains the system would become unstable.

So the initial bandwidth could never be recovered by a pure gain. Due to the fact that the dynamic will change very rapidly the pilot will have no time to adapt to the new situation. Instinctively he will increase his gain which leads to the described control problems.

RLE's in flight control systems require a detailed analysis by considering the input amplitude in order to define the RLE-onset margin.

However it must be considered that the frequency analysis for a control loop presumes steady state oscillation conditions where the pilot 'has time to adapt' to the changed dynamics. In real flight the dangerous PIO prone situations are given by the unforeseen dynamic change where the pilot is not able to adapt fast enough to the new dynamics.

Therefore devices have to be implemented in flight control systems which are able to avoid rate saturated conditions or which 'improve' the dynamics such that the flying qualities are only degraded but not so much that PIO could develop.

The potential of ACS to avoid PIO in rate limited situations as proposed in [1] will be discussed in the next chapter.

7.3 Potential of ACS on handling qualities

The alternate control scheme (ACS) providing the sign of the output signal rate equal to the input rate if the rate limiter is active means that the phase delay becomes

zero.

This situation is shown in the time domain in figure 17 and in the frequency domain in figure 18 (Nichols plot).

In the Nichols plot curve D represents the frequency response of the rate limited system with an ideal phase compensation. The frequency response is only effected by amplitude reduction. It can be seen that the pilot could recover the initial bandwidth by increasing his gain without any danger of instability. System degradation is only given by the fact that the system is gain limited.

Similar results could be obtained by using the Gibson criterion [7] where the phase rate at the -180 phase is used to predict PIO behaviour (Figure 19).

The solid curve represents a modern fighter type airplane. Assuming a RLE onset at $\omega = 2.3$ rad/s (dotted curve) PIO is predicted. The same situation with RLE compensation by ACS is illustrated by the bar-dot curve. In this specific case the total behaviour would even be improved by the compensated RLE compared to the initial configuration.

So the ACS seems to be a good solution to avoid PIO's when RLE's become active in flight control systems by assuring at least level 2 flying qualities.

8. CONCLUSIONS

Rate limiter describing functions have been derived and have been used in pilot/aircraft analysis by using established methods. By this, insight into the influence of RLE's in flight control systems has been gained showing that phase and amplitude are heavily reduced if the RLE becomes active. As a key parameter the RLE-onset frequency was defined which can be used as a measure of the input amplitude. RLE's in flight control systems make system dynamics input amplitude dependent which leads to the requirement

to define input amplitude dependent handling qualities too. Here the onset frequency of RLE's in reference to the bandwidth frequency could be a suitable parameter to define handling quality boundaries for flight control systems with RLE's. Further, the frequency response behaviour of RLE cascading configurations has been derived showing that the overall system dynamics will additionally be degraded and therefore should be avoided in any case.

From a handling qualities standpoint the main problem is seen by the fact that control dynamics will change suddenly when RLE's onset and the pilot is not able to adapt fast enough to the changed dynamics. Instinctively he will respond by increasing his gain to compensate the bandwidth reduction.

Because a pilot's adaptation capability depends strongly on his skill RLE onset is generally dangerous and PIO could happen. Therefore, RLE onset should be prevented in any case or if so the consequences of RLE should be reduced so that at least level 2 flying qualities are assured.

It is shown that the ACS as a means for counteracting RLE phase delay could fulfil these requirements.

9. REFERENCES

1. A'Harrah, R.C.,
"Communique with DLR and others,"
NASA HQ, Washington DC,
July 14, 1992
2. Buchholz, J.J.,
"Saturated command and rate limited
elevator time delay, SCARLET,"
DLR IB 111-93/18, April 1993
3. Ohmit, E.E.,
"Testplan for NT-33 In-flight
investigation into flight control system
rate limiting,"
Calspan NT-33A TM No. 605, June
1993
4. Hanke, D.,
"The influence of rate limiting
elements in flight control systems on
handling qualities,"
DLR IB 111-93/61, September 1993
5. Neal, T.P., Smith, R.E.,
"An in-flight investigation to develop
control system design criteria for
fighter airplanes," Vol. I and II
AFFDL-TR-70-74, 1970
6. Hoh, R. et al.,
"Proposed MIL Standard and
Handbook
-Flying Qualities of Air Vehicles,"
Volume II: Proposed MIL Handbook
AFWAL-TR-82-3081, Volume II
November 1982
7. Gibson, J.C.,
"Piloted handling qualities design
criteria for high order flight control
systems," AGARD-CP-333 on "Criteria
for handling qualities on military
aircraft," April 1982 pp.4.1-4.15

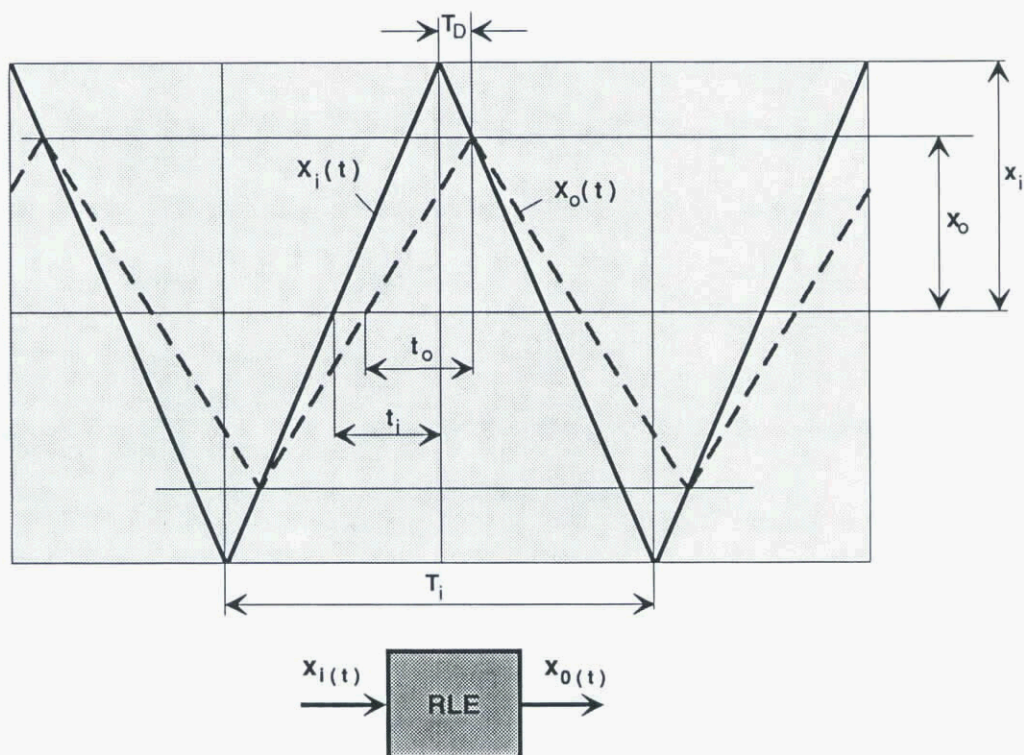

Figure 1 RLE time response (triangle type input)

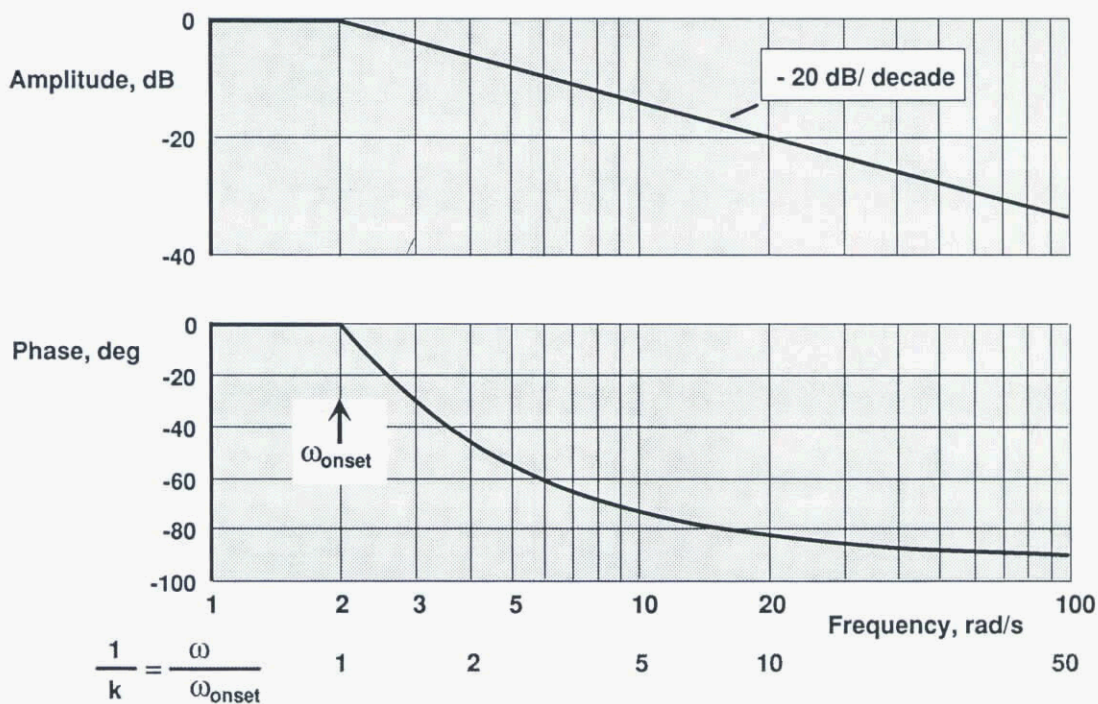

Figure 2 RLE frequency response (triangle type input)

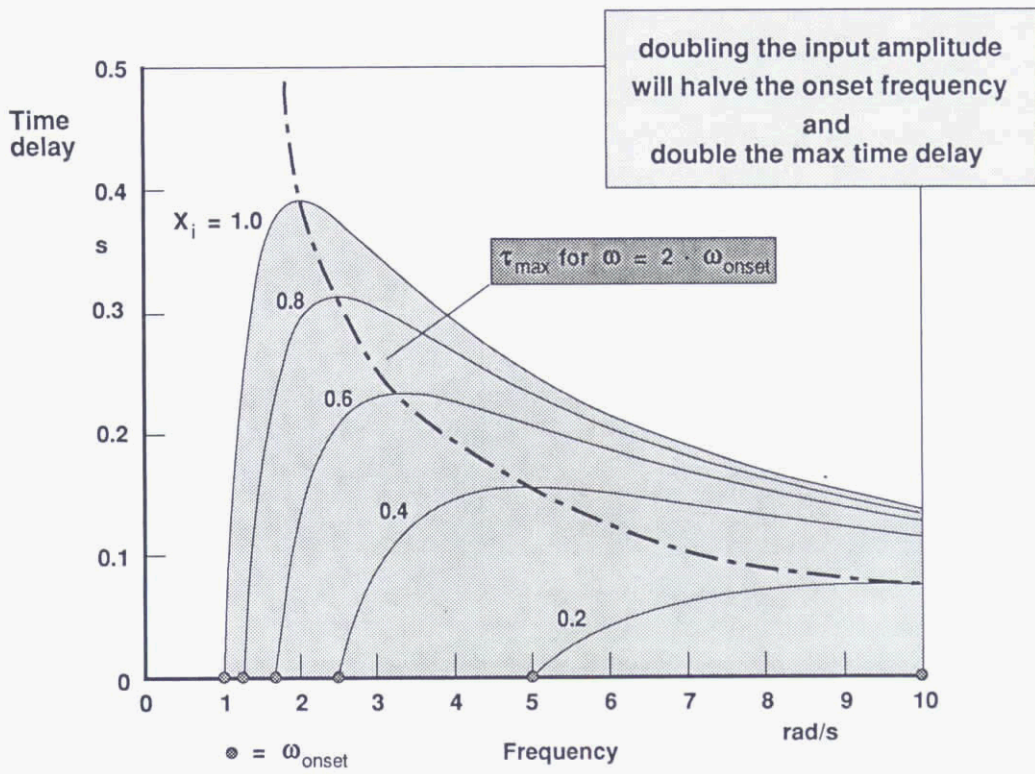

Figure 3 RLE produced time delay

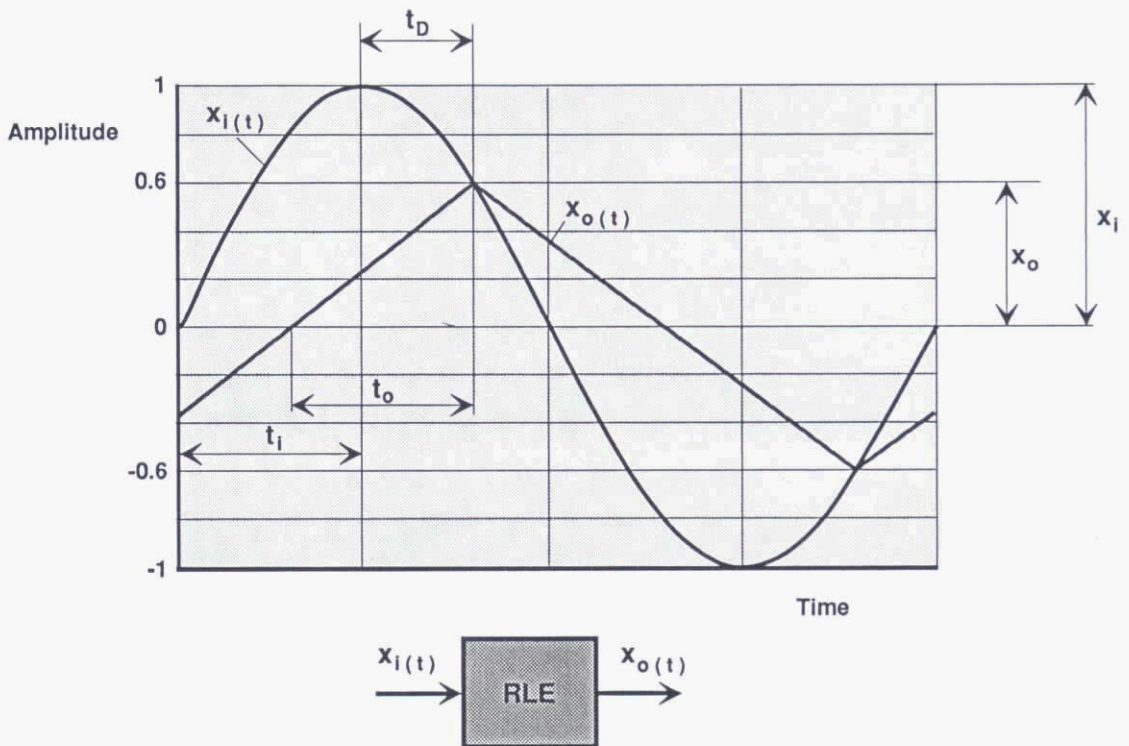

Figure 4 RLE time response (sinusoidal input)

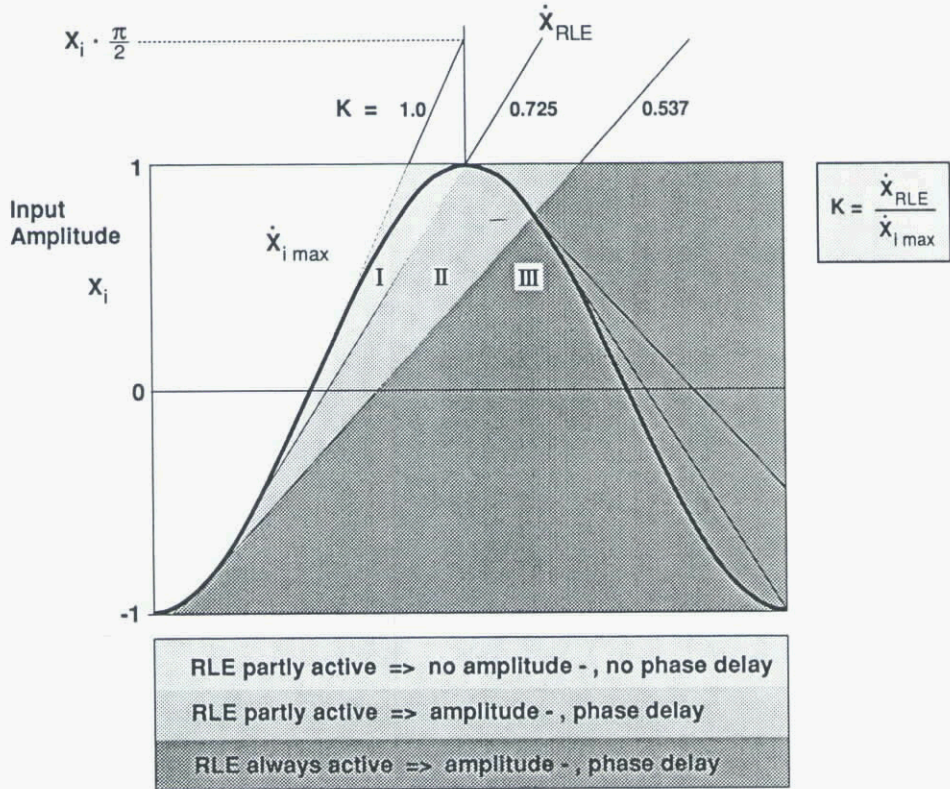

Figure 5 RLE time response (sinusoidal input)

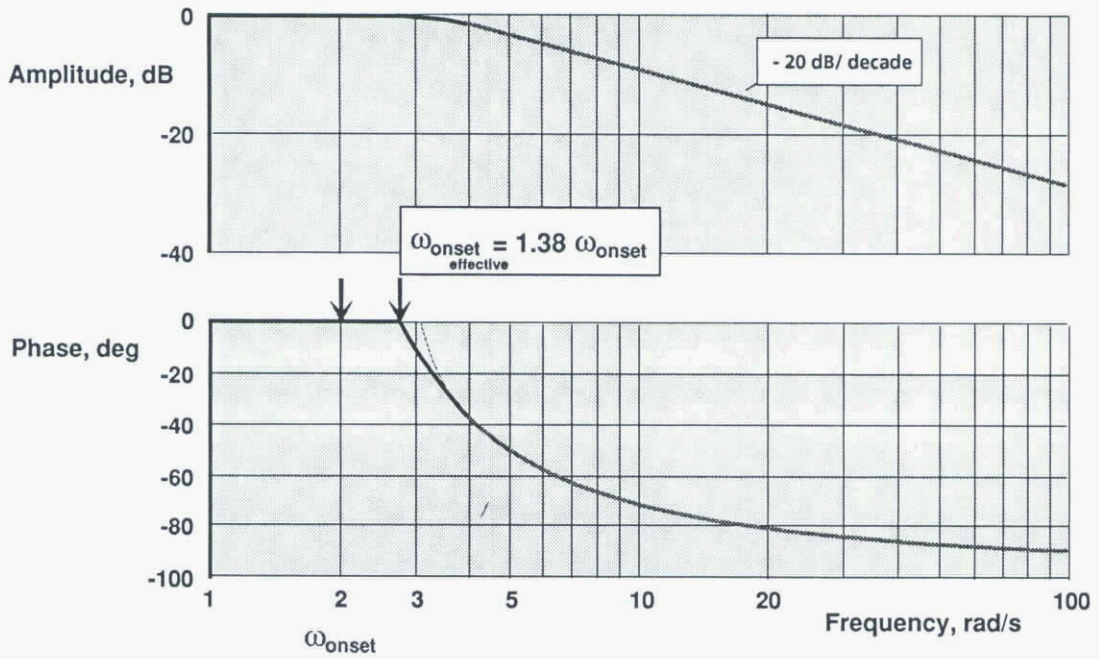

Figure 6 RLE frequency response (sinusoidal input)

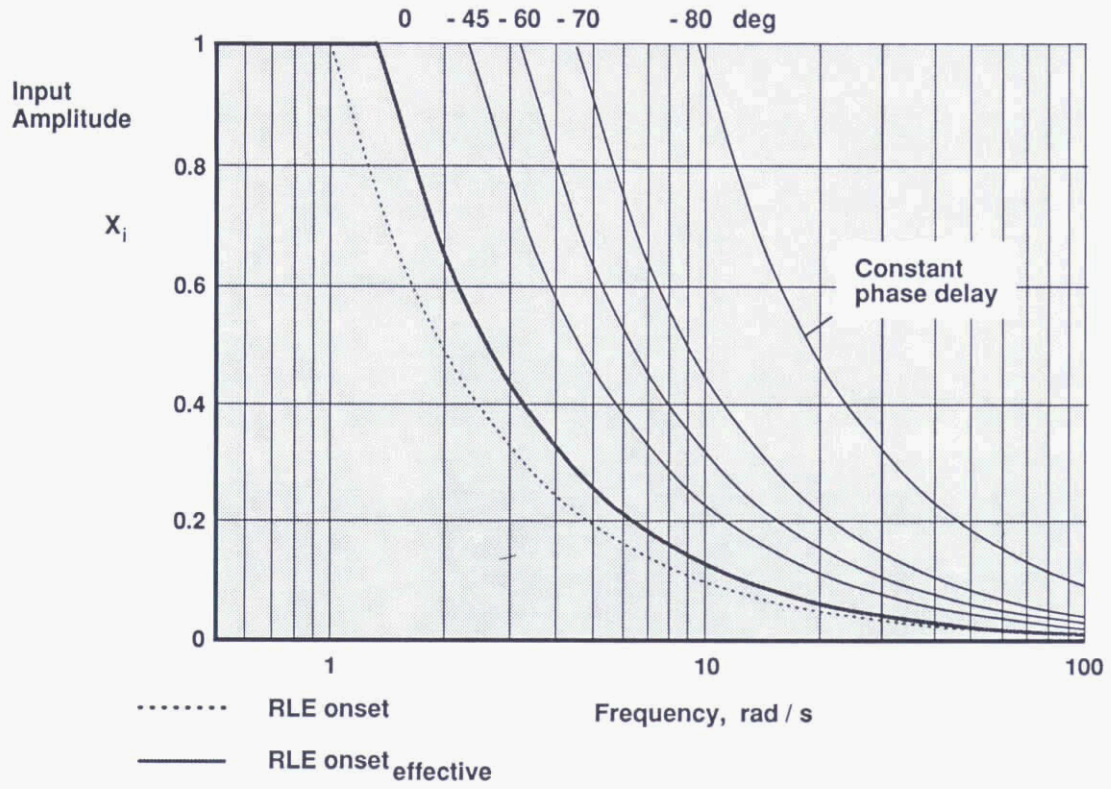

Figure 7 RLE produced phase delay

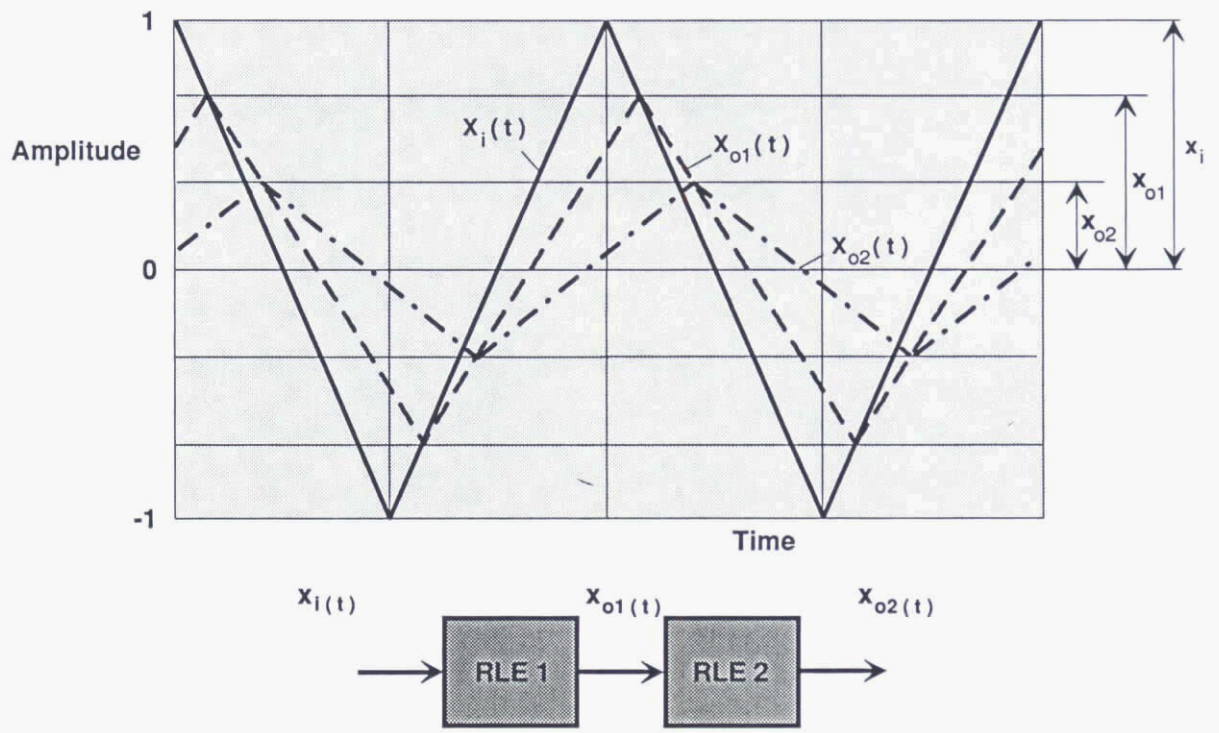

Figure 8 RLE cascading time response

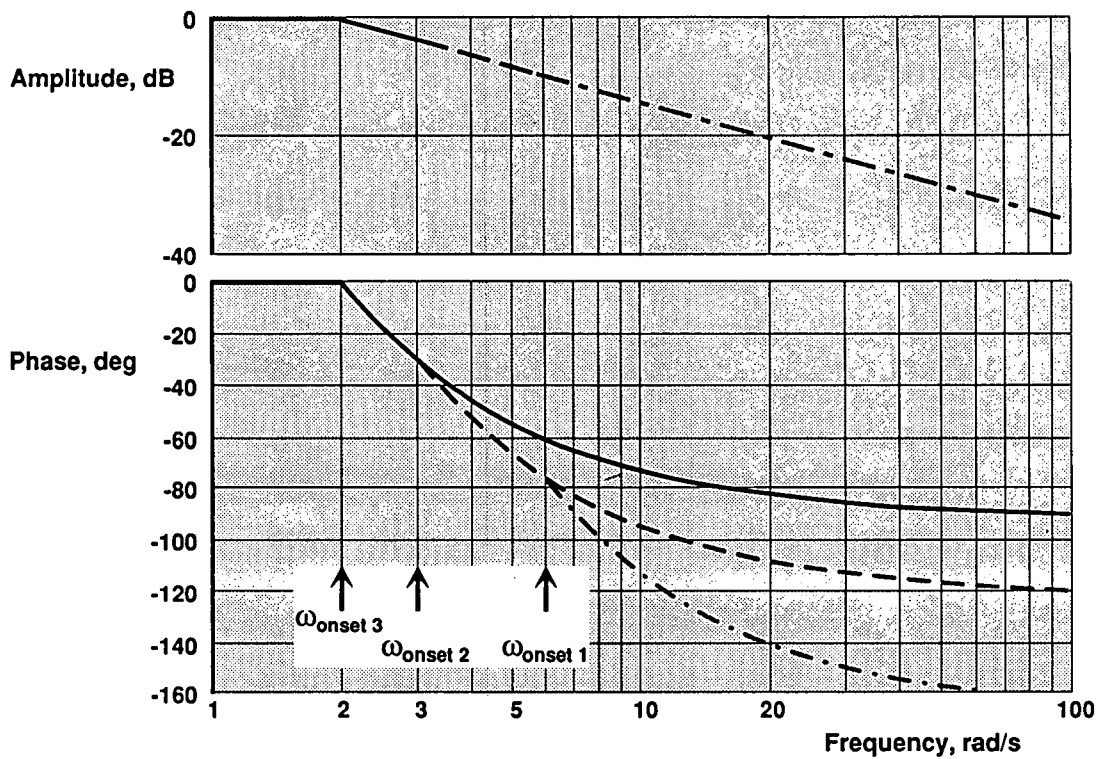

Figure 9 Cascaded RLE frequency response (triangle type input)

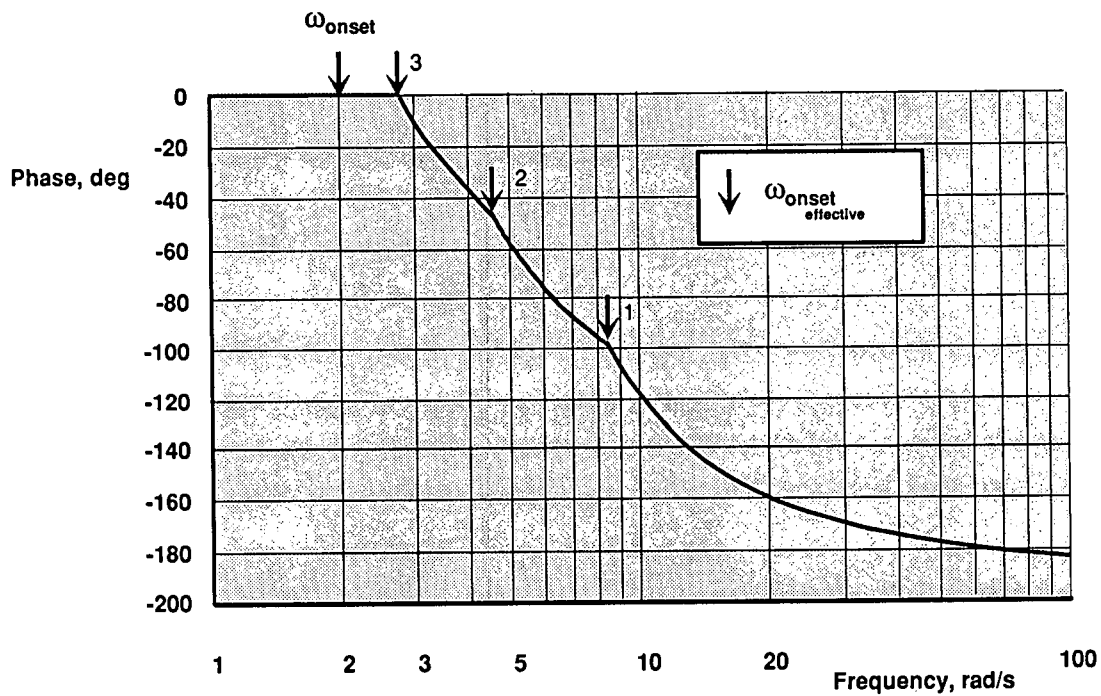

Figure 10 Cascaded RLE frequency response (sinusoidal input)

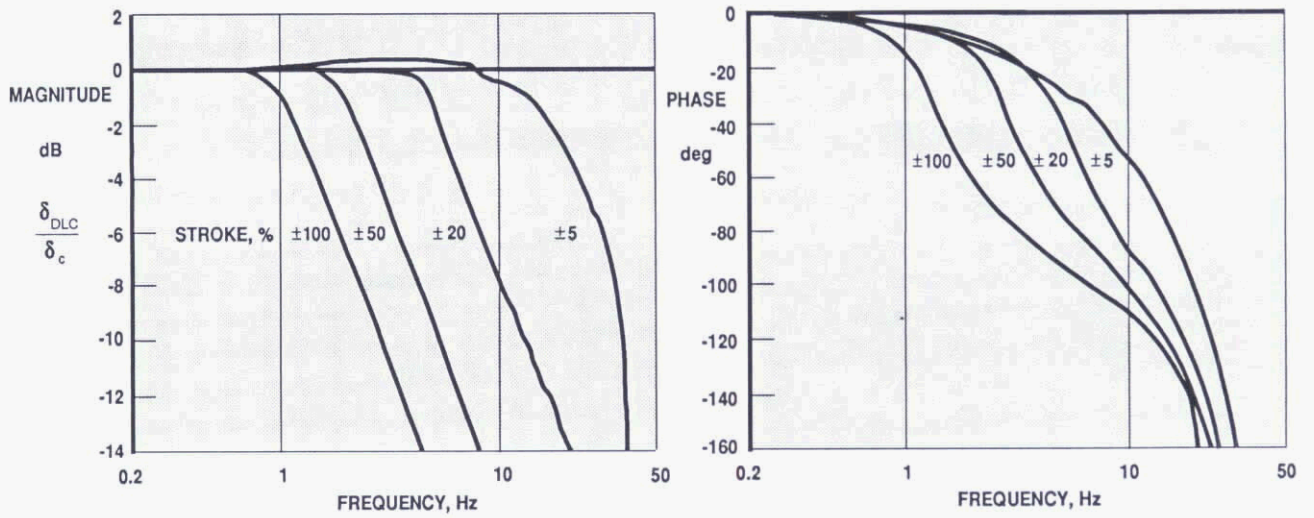

Figure 11 Measured frequency response of a rate saturated actuator

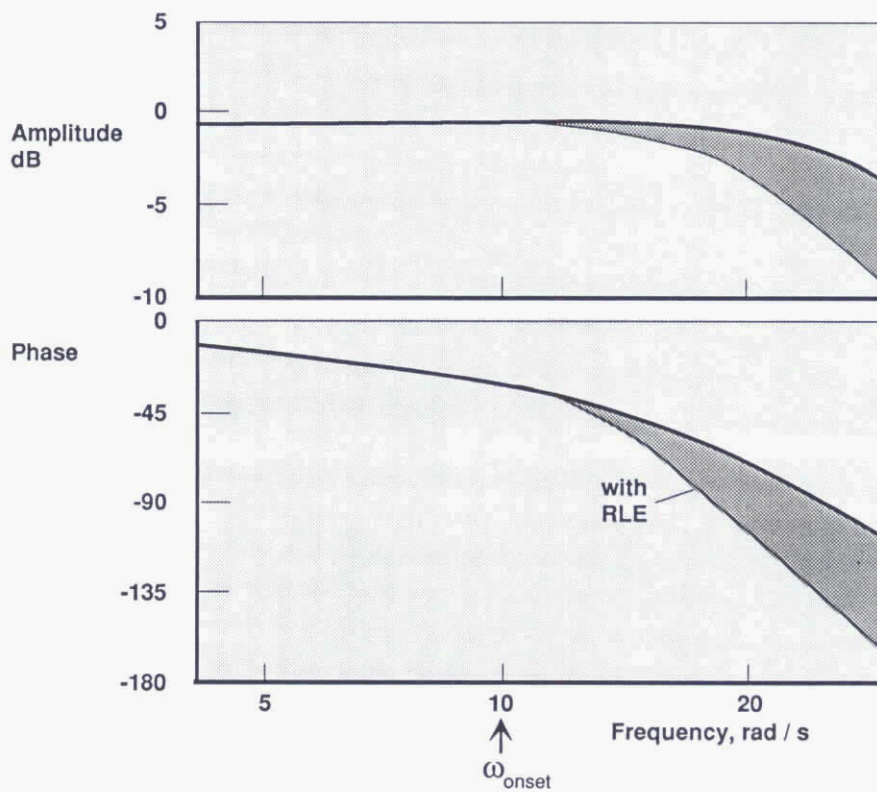

Figure 12 Actuator frequency response with input rate limitation

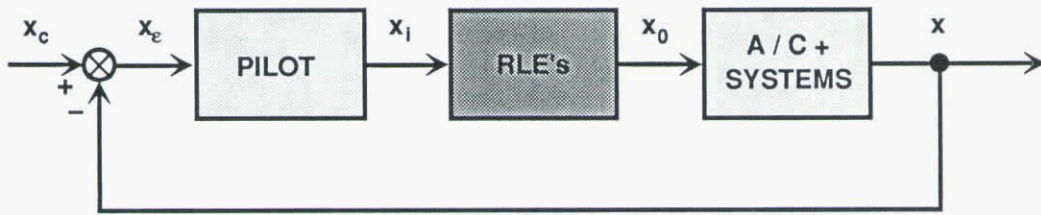

Figure 13 RLE's in pilot/ aircraft system

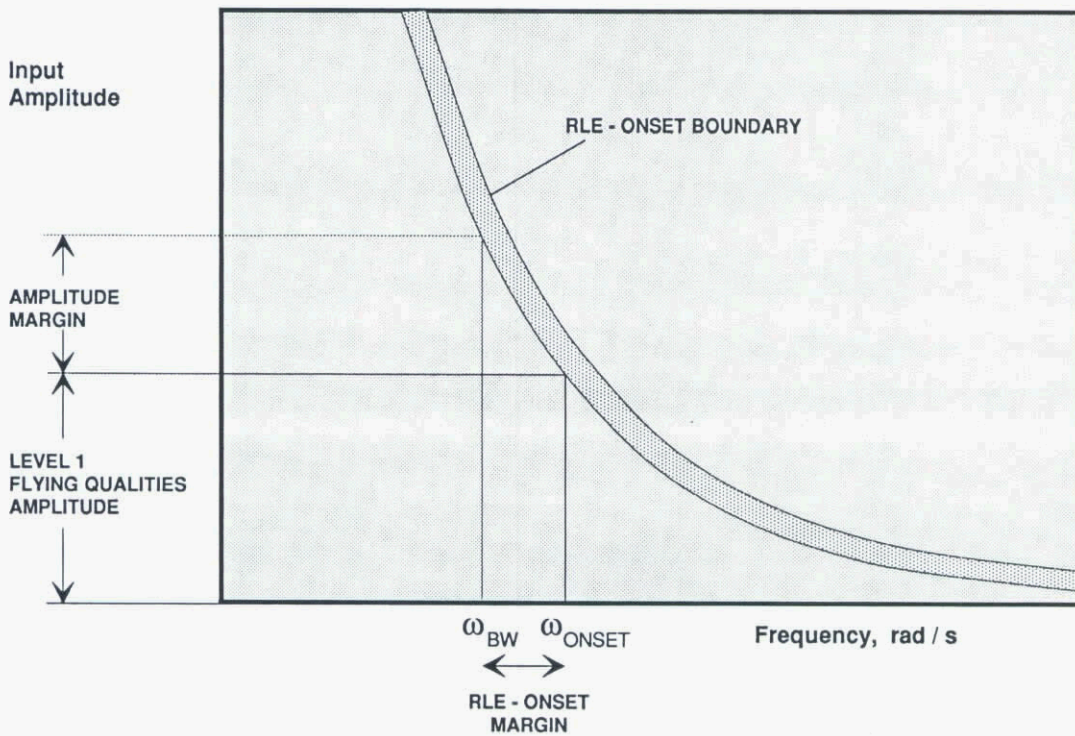

Figure 14 RLE onset frequency - a flying quality parameter

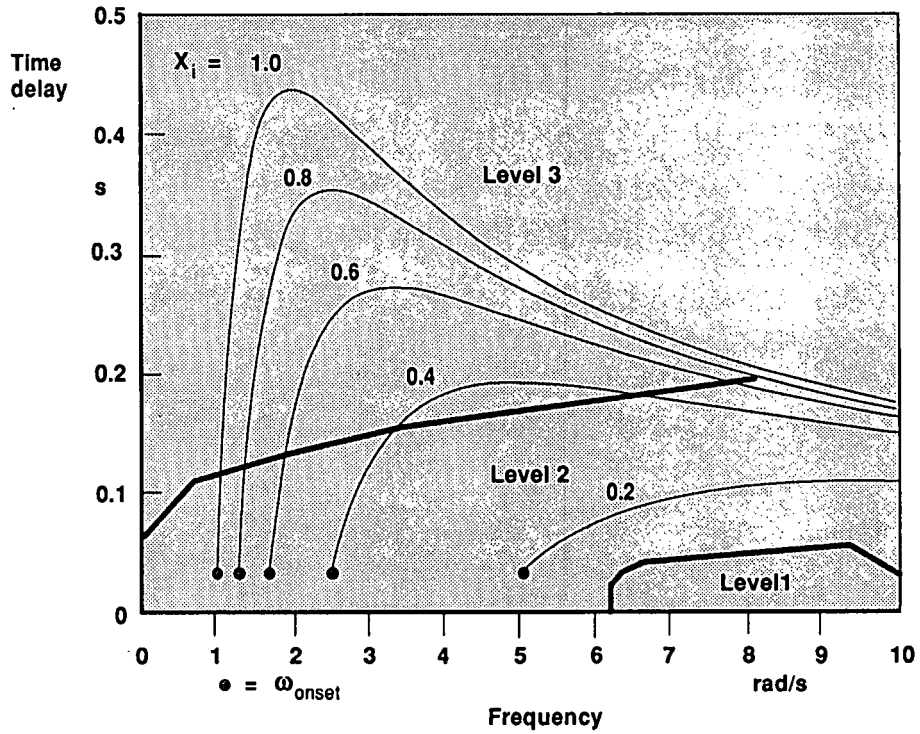

Figure 15 RLE influence on bandwidth criterion

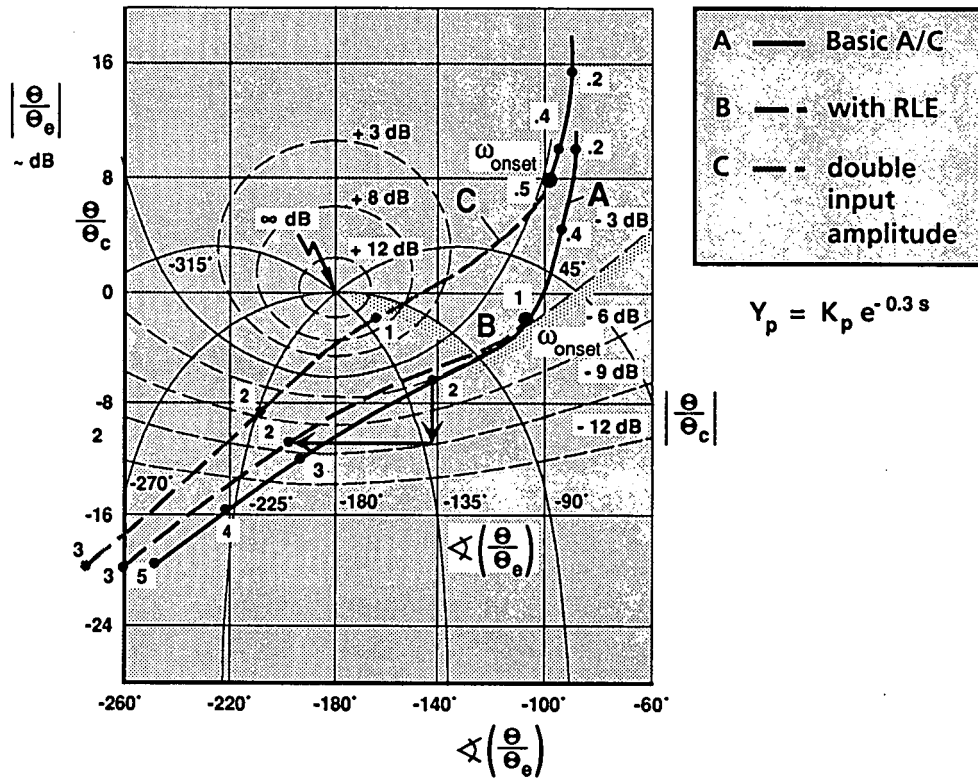

Figure 16 Influence of RLE on open/ closed loop system

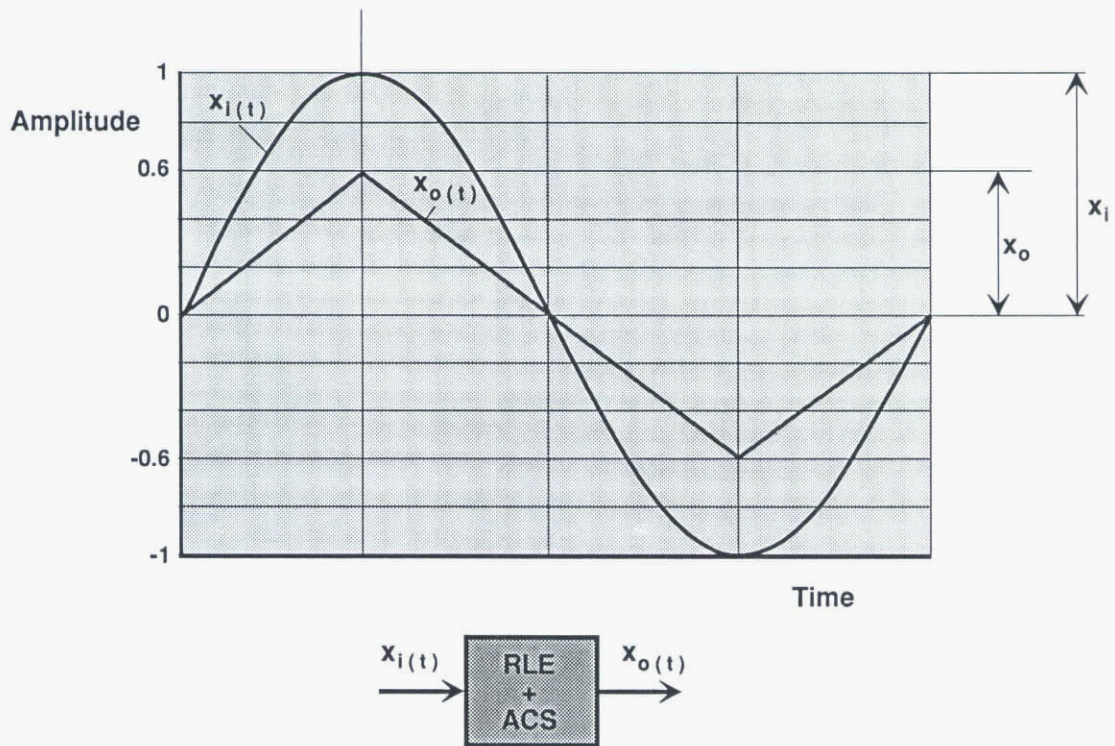

Figure 17 RLE compensation by alternate control scheme (ACS), time response

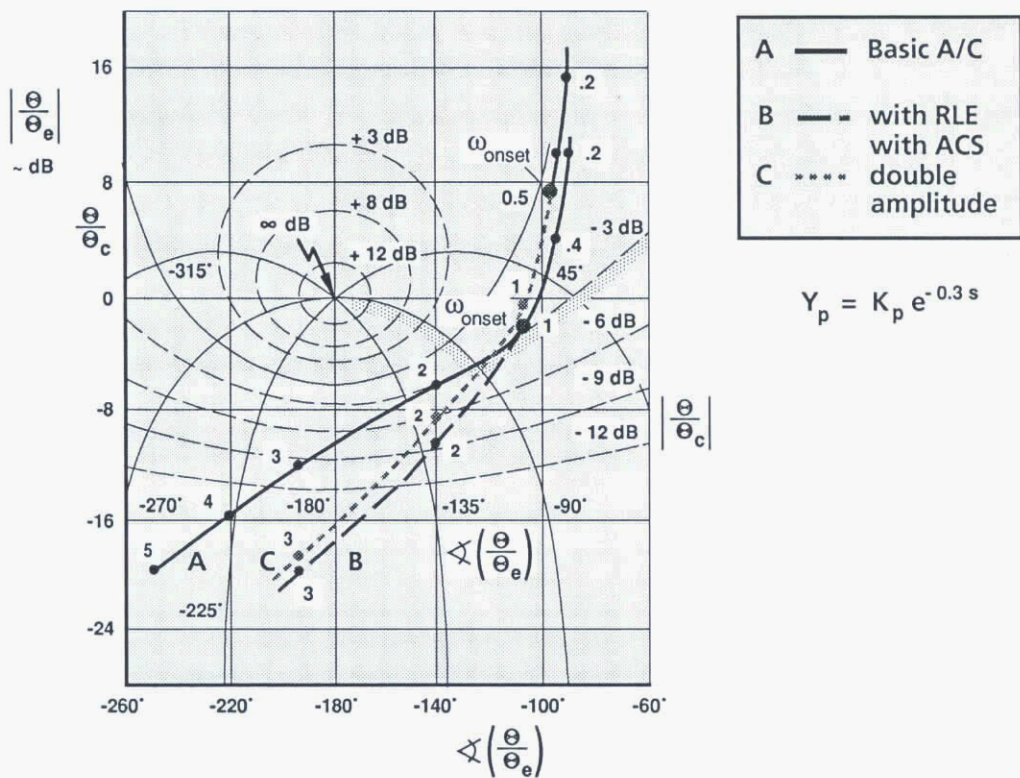

Figure 18 RLE compensated by ACS, frequency domain

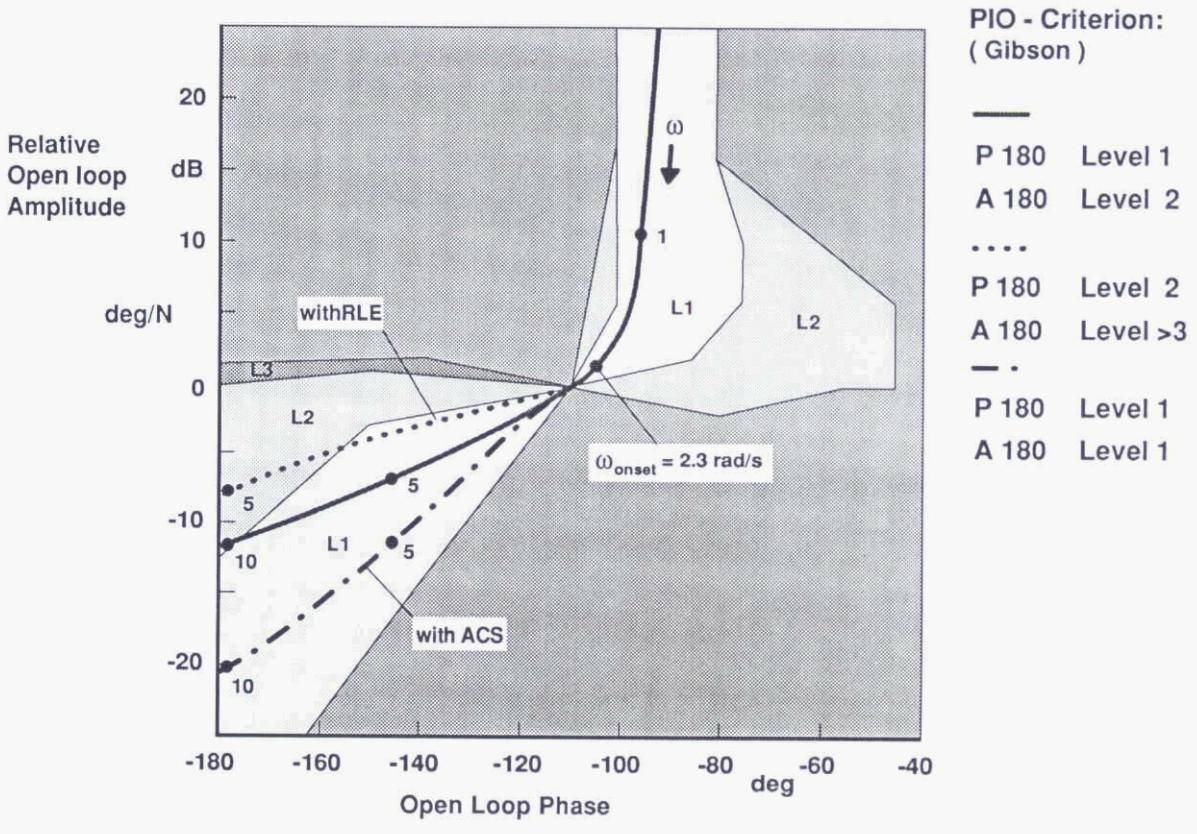

Figure 19 Pitch frequency response limits (Gibson criterion)

Calspan Experience of PIO and the Effects of Rate Limiting

presented by

Mr. Charles R. Chalk
Consultant
4150 Harris Hill Rd.
Williamsville
New York 14221
United States

formerly of
Arvin Calspan Corporation
Buffalo, New York

1) Introduction

The experience of PIO within the Calspan Corporation is considerable, following a long standing interest in the subject. During this experience, the major concern that has been uncovered is that of the attitude towards the pilot following a PIO incident. There is still a tendency in many areas of aviation to consider a PIO as a failure of the pilot, whereas it must be properly regarded as a failure of the control system and its design process.

Over a period of some years, the Calspan Corporation have undertaken a series of experiments with the NT-33A and Lear Jet aircraft to examine the effects of rate limiting compensating devices. The notes which follow summarise the presentation given on some of the aspects which have been investigated both analytically and experimentally in flight tests.

2) Simple Pilot Models

The interest in pilot modelling has re-awoken with the recent incidents resulting in the losses of the YF-22 and JAS-39 aircraft. In the past, a number of authors have identified that human dynamics are a primary cause of PIO, with lack of piloting skill and errors of judgement under stress as contributing factors in the occurrence of PIO.

From a study of PIO incidents, all of which involved control surface rate limiting, it was observed that the pilots tended to switch the sign of their control command when either pitch or roll rate changed sign. This is illustrated by the vertical dashes on the time histories of the PIOs in the NASA Digital Fly-By-Wire (DFBW) F-8 (figure 1) and the Calspan Learjet (figure 2).

These time histories show that, when rate limiting is present, the pilots will tend to adopt a simple non-linear, "bang-bang" mode of control at a selected amplitude which exhibits a finite rate of change and which is keyed by either the zeroes on the rates or the attitude peaks. The sense of the control action is as follows, for figure 1:

1. Nose rising; hold the stick forward,
2. Nose stops; keys switch to aft stick,
3. Nose falling; holding stick aft,
4. Nose stops; keys switch to forward stick.

For the traces shown in figure 2, then a similar trend is seen, but related to roll rate and roll attitude. The model which this gives of the pilot action is very similar to that proposed by Ralph Smith in his presentation.

All of the PIOs which have been examined during the course of this investigation have seemed to feature this behaviour. The default control mechanism used by the pilot is perhaps contained within the pilot's brain.

2.1) Analytical Modelling Results

Figures 3 and 4 show two forms of the modelling which have been used to simulate the effects of rate limiting in this study of PIO sensitivity and mechanisms. The model was created using a Simulink modelling facility and is matched to the results of tests performed on the Calspan Learjet aircraft.

The results, shown in figures 4, 5 and 6, clearly indicate a decrease in oscillation frequency as the input amplitude is increased. With this model, it was possible to examine which terms influenced the response of the aircraft. From this study, rate limiting has a very clear influence on the frequency. A PIO prone aircraft has a lower frequency than a good aircraft,

the consequence is that as the PIO frequency is approached, the amplitude of the motion will increase. The effect of actuator rate limiting is to rapidly cause the amplitude to increase as the rate limits are reached.

The characteristics are the same as shown by Ralph Smith's model.

Summarising the findings, the non-linear pilot model developed exhibits trends which closely match the trends observed in flight test for PIO incidents involving surface rate limiting. Such a model may be used to discriminate analytically between PIO free and PIO prone systems. Using such a model, it could be possible to define a design criterion along the lines of if the frequency at the crossover point is less than 4.5 rad/second, then there will be a problem if the response grows monotonically with increase of input amplitude.

3) Software Rate Limiter Concepts

As already described, a software rate limit concept had been proposed by Ralph A'Harrah and this proposal has resulted in several studies being performed on the Calspan Learjet aircraft, in addition to those experiments already described by DLR on their ATTAS aircraft.

The rate limit concept (RLC) has the following form:

$$\text{IF } |\delta_{c(n)} - \delta_{c(n-1)}| / > \delta_{oLIMIT} \Delta T \text{ THEN}$$

$$\delta_{o(n)} = \delta_{o(n-1)} + \text{Sign Of } [\delta_{c(n)} - \delta_{c(n-1)}] \delta_{oLIMIT} \Delta T$$

$$\text{ELSE IF } |\delta_{c(n)} - \delta_{c(n-1)}| / < \delta_{oTHRESHOLD} \Delta T \text{ THEN}$$

$$\delta_{o(n)} = \delta_{o(n-1)} + [\delta_{c(n)} - \delta_{c(n-1)}]$$

$$+ (1 - e^{-K_f \Delta T}) [\delta_{c(n-1)} - \delta_{o(n-1)}]$$

$$\text{ELSE } \delta_{o(n)} = \delta_{o(n-1)} + [\delta_{c(n)} - \delta_{c(n-1)}]$$

where

δ_c	=	RLC input
δ_o	=	RLC output
ΔT	=	Sample Time
n	=	Frame count
δ_{oLIMIT}	=	Rate limit
$\delta_{oTHRESHOLD}$	=	Rate threshold for activation of bias removal
K_f	=	Bias removal inverse time constant

The software rate limiter described above was implemented in the pitch and roll commands of the Calspan Learjet aircraft with a software cycle time of 10 milliseconds.

A series of tests were performed by Rogers Smith from NASA Dryden, the tests consisting of a powered approach with an offset to be corrected just prior to touchdown on the runway. The basic characteristics were chosen to give an aircraft with a quick, but not objectionable, response. The rate limit and transport delay were then added until the aircraft became PIO prone. The rate limiter was removed and the aircraft evaluated to establish the PIO prone tendency was due to the rate limiter and not the delay, (Figure 7). The rate limiter was then added and the landing task performed. In this way, the impact of adding in the rate limiter control algorithm could then be established.

Variations of command gain were made for a chosen rate limit value of 50°/sec, with up to double gain being examined. Lastly, the roll stick deflection per pound was reduced by a third and the position command gain to the ailerons was tripled so as to keep a constant roll response per pound.

All of the variations were evaluated with the same offset approach and landing technique and Cooper Harper ratings given for the resulting handling qualities. PIO ratings were assigned in accordance with the Chalk PIO Tendency Classification scale.

4) Results

Configurations with slightly high command sensitivity, time delay in the command path and phase shift associated with rate limiting were evaluated as Level 3 with strong PIO tendency in this offset landing task.

When the rate limiter concept software was added to the command path, these configurations were raised to high Level 2 in their ratings with no PIO tendency, although undesirable motions were still observed during the landing task.

Tables 1 and 2 summarise the tests which were performed, whilst Table 3 summarises the findings of the flight test evaluations with and without the RLC concept operating.

These findings were very clearly supported by the video recordings of these landings, which were shown following the completion of this presentation. Subsequently, further tests have been performed to assess the efficacy of the rate limiter concept and these have broadly given similar conclusions.

5) Conclusions

The effect of the rate limiting control concept is to convert an aircraft which would be rated as Level 3 and PIO prone to one with improved Level 2 handling and which is non-PIO prone, although there are some unusual tendencies for the pilot to become accustomed to, relating to the apparent non-linearity of the command characteristics. There is also a need to attend to the fading out of the rate limiter algorithm if the effects of mismatched demand and control position are to be minimised.

Certainly, the concept has been demonstrated to be beneficial in overcoming the adverse effects of actuation rate limiting

and does appear to be worthy of further detailed investigation. Further work on the fading out of the rate limiting algorithm will be essential for the adoption of the system into a real aircraft project.

References

1. C.R.Chalk
"Study of a Software Rate Limit Concept"
FRM No. 636; IR&D No. 85-892
2. C.R.Chalk.
"Pilot Models for PIO Analysis and Roll Ratchet Anaysis"
FRM No. 650; IR&D No. 85-901
3. P.R.Deppe.
"Flight Evaluation of a Software Rate Limiter Concept"
Calspan Report 8091-1
4. P.R.Deppe, C.R.Chalk, M.Shafer.
"Flight Evaluation of an Aircraft with Side and Centerstick Controllers and Rate Limited Ailerons"
Calspan Report 8091-2

Figure 1

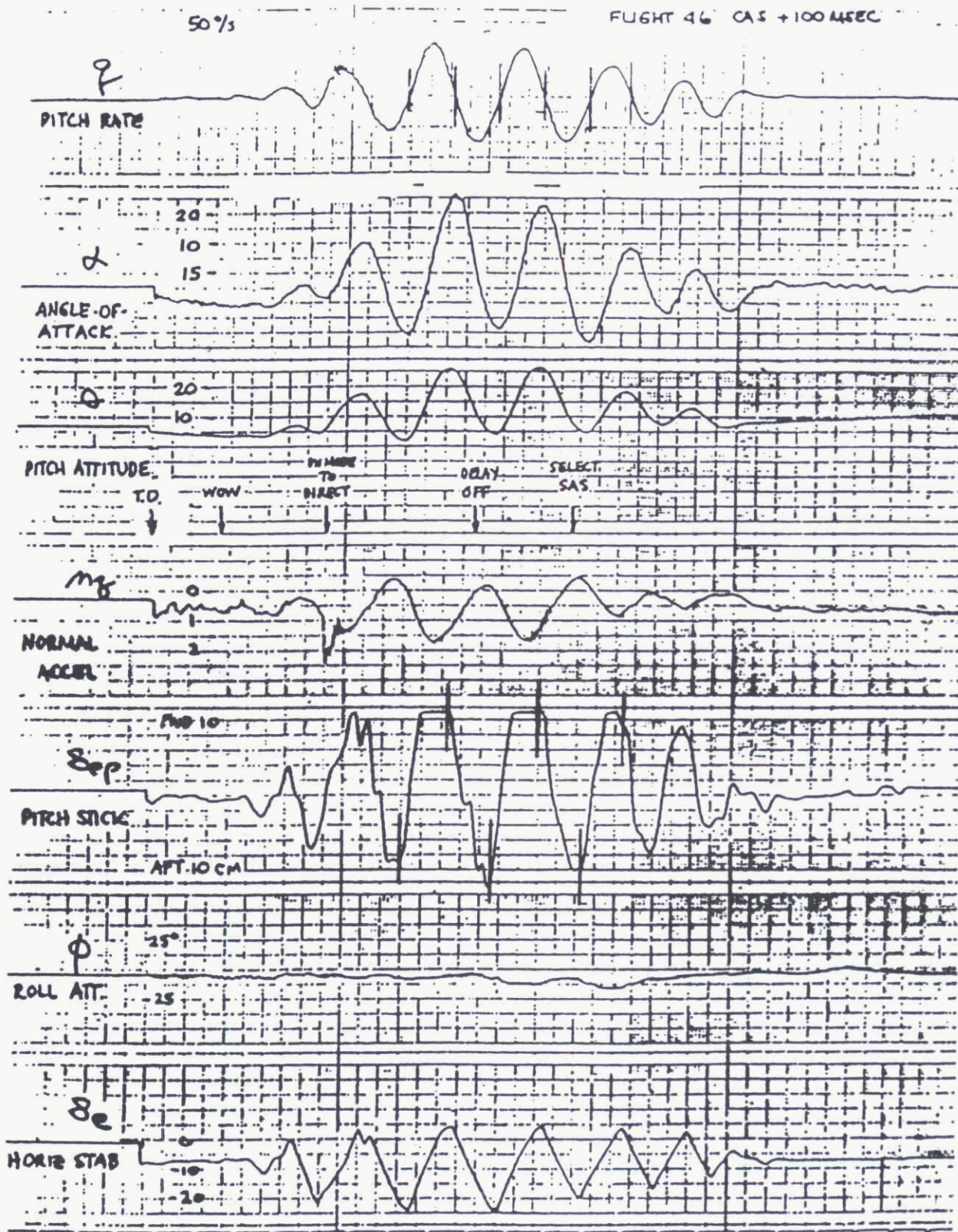

Fig. 1 Flight Recording of F-8 DFBW PIO
(NASA Ames/Dryden Flight Research Facility)

12-6

Figure 4

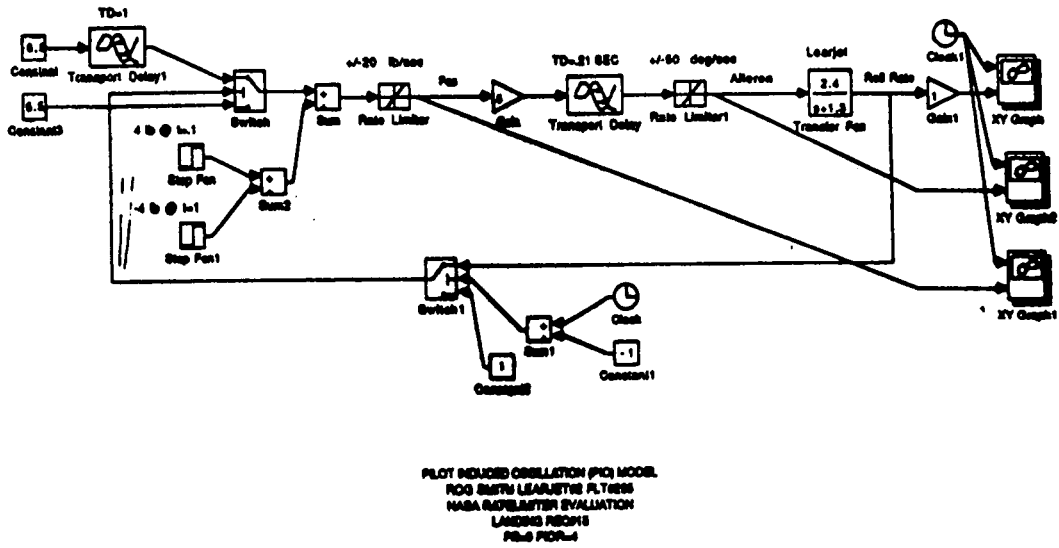

Figure 5

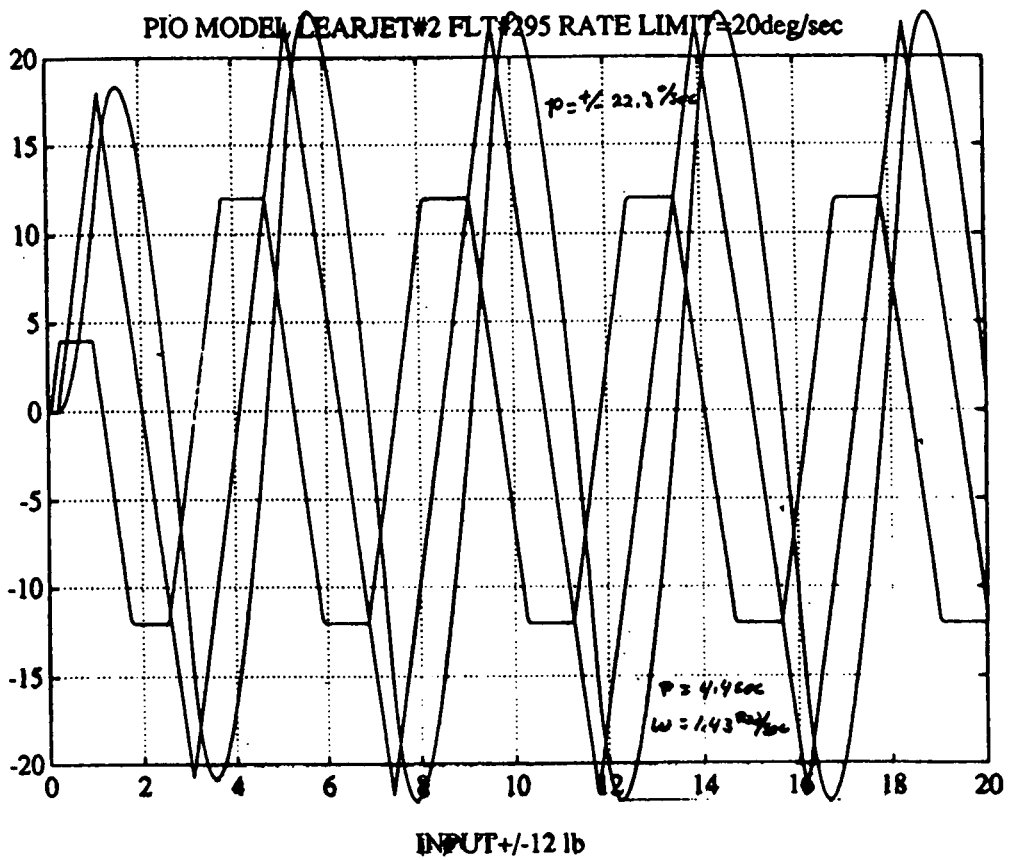

Figure 6

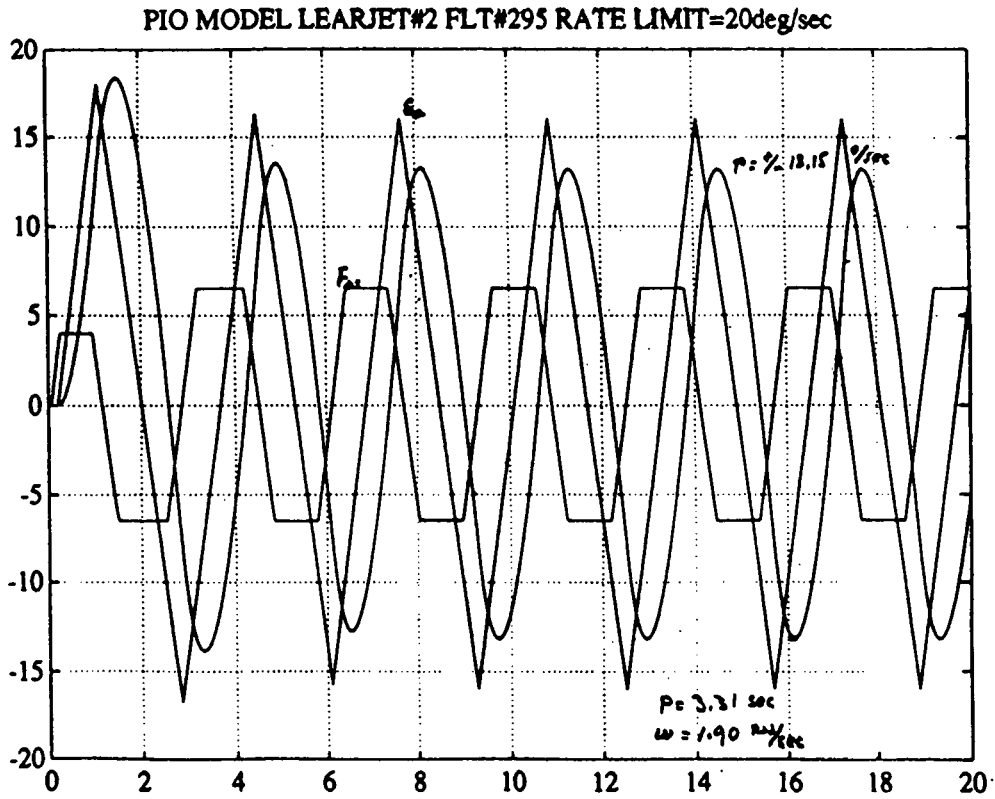
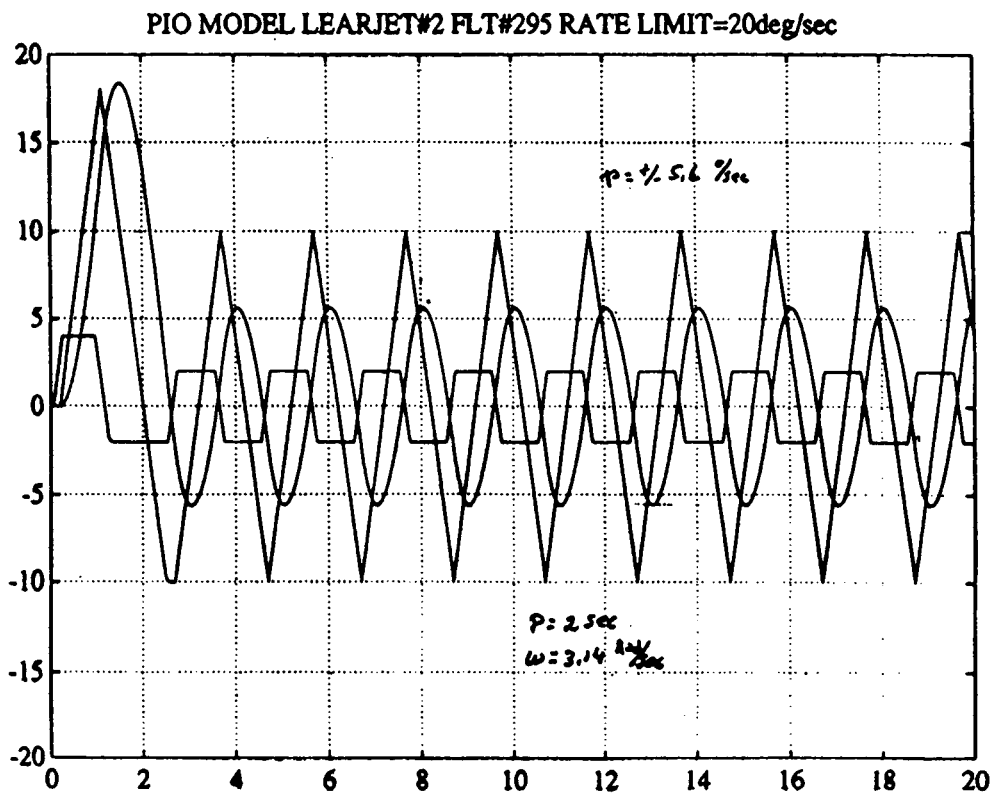

Figure 7



12-8

Figure 8

Non-Linear Airplane

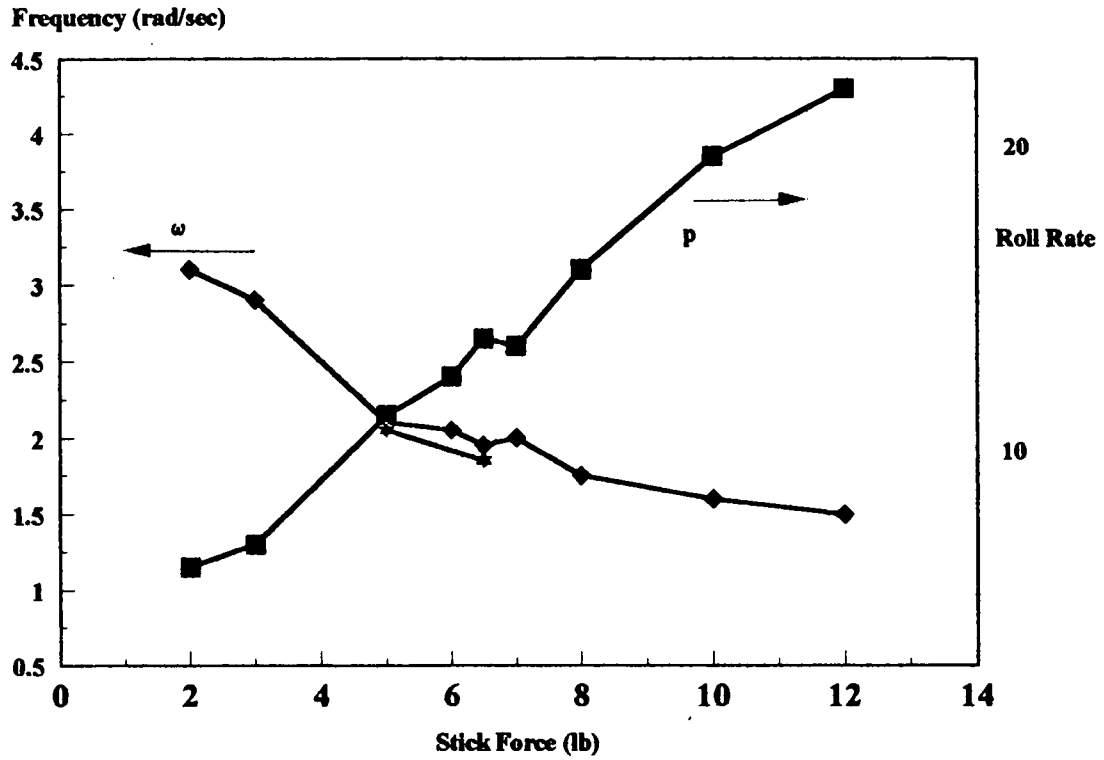

Figure 9

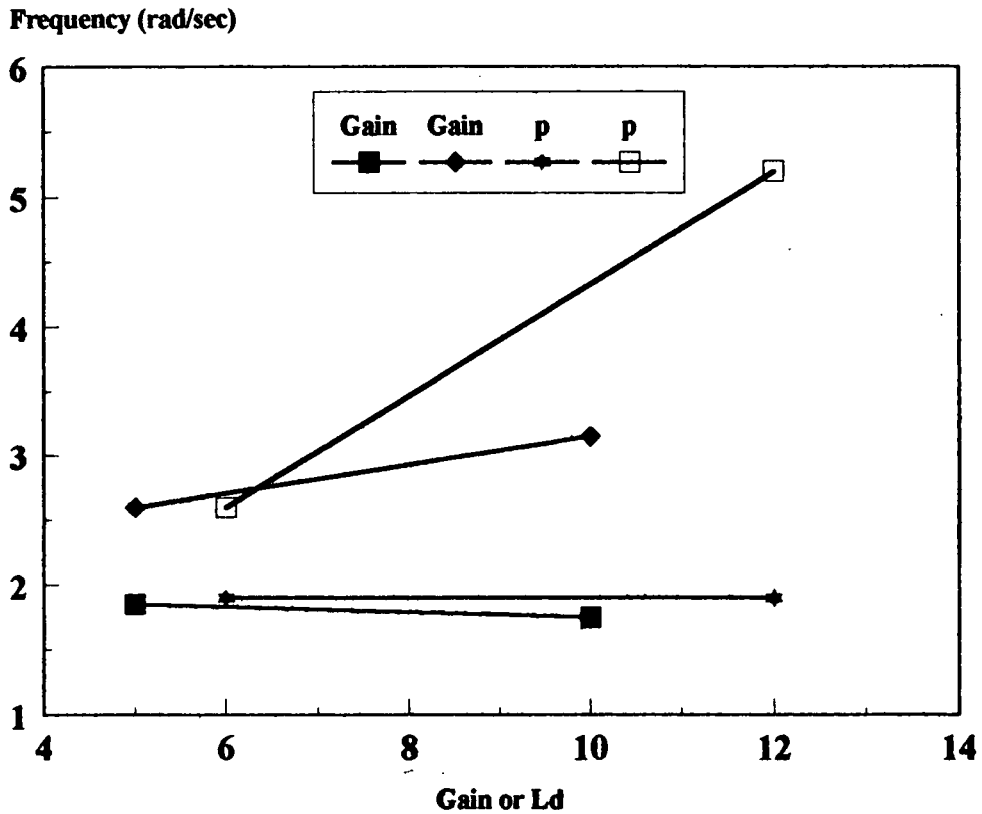

Figure 10

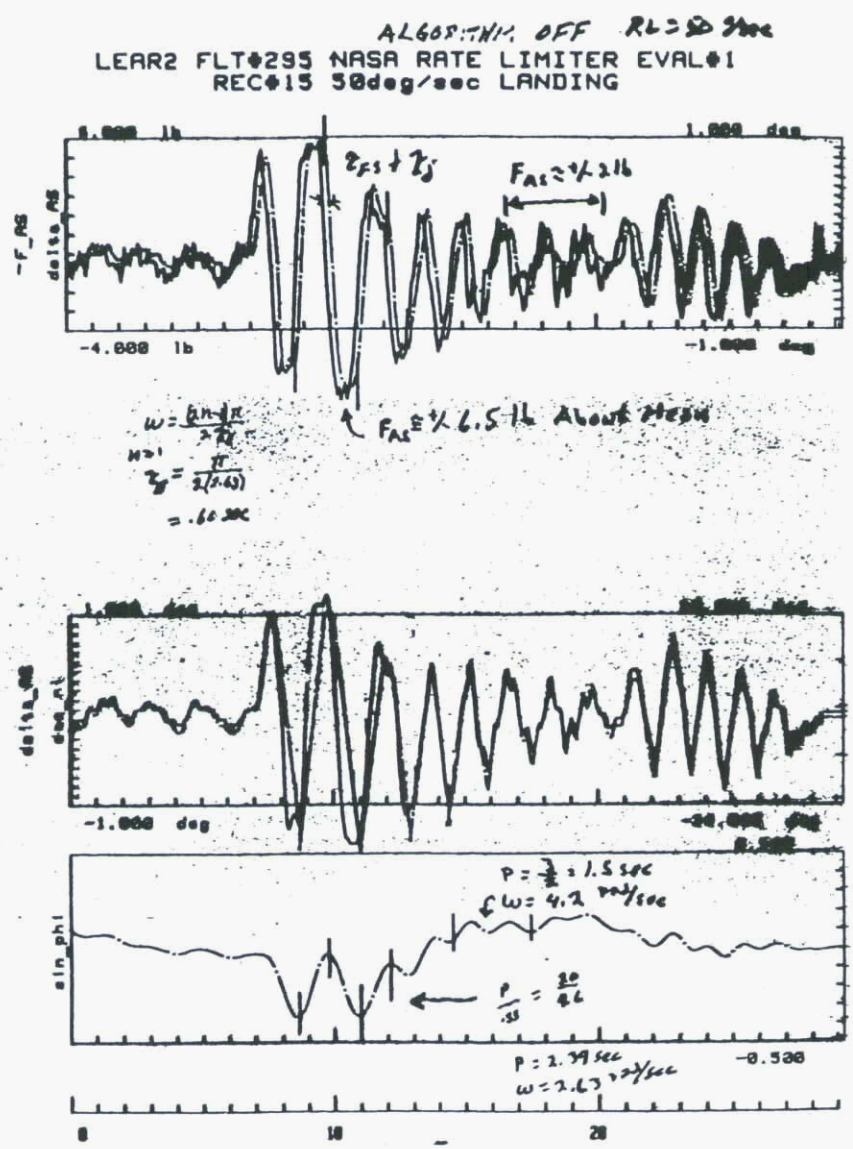
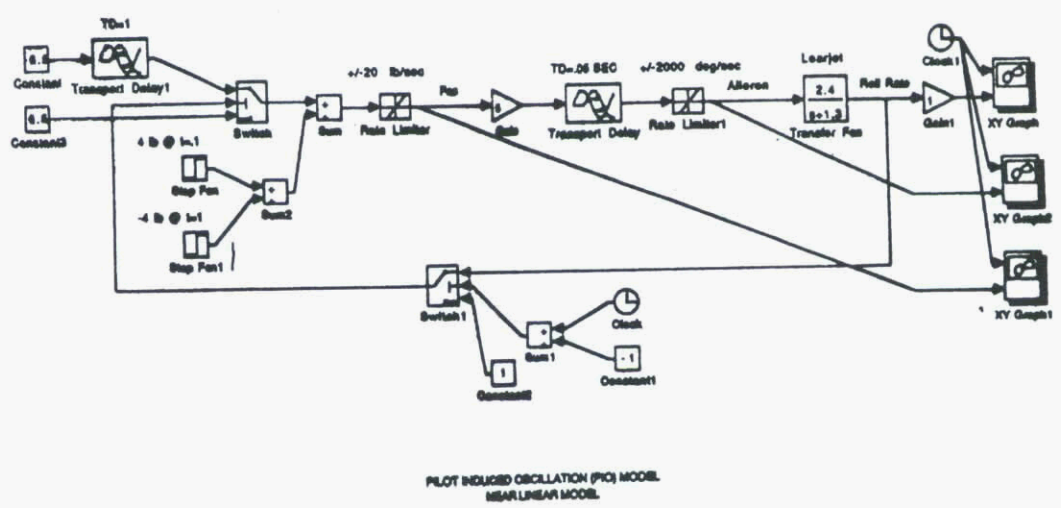

Figure 11



12-10

Figure 12

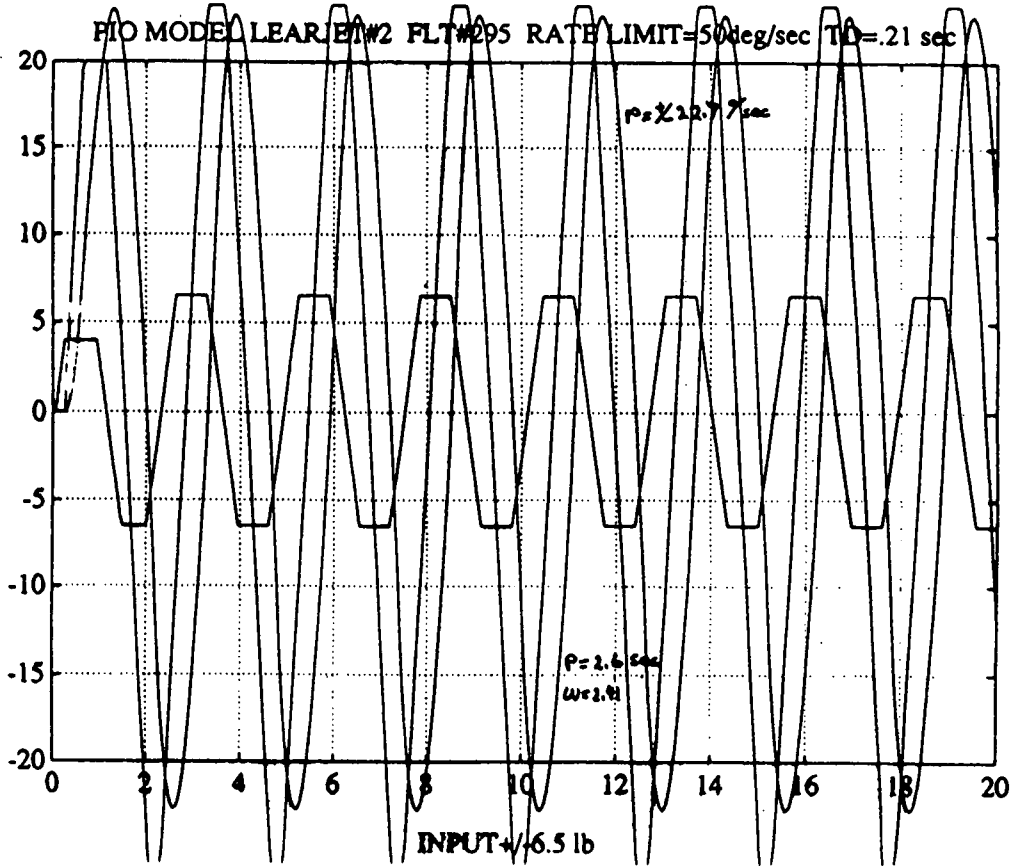

Figure 13

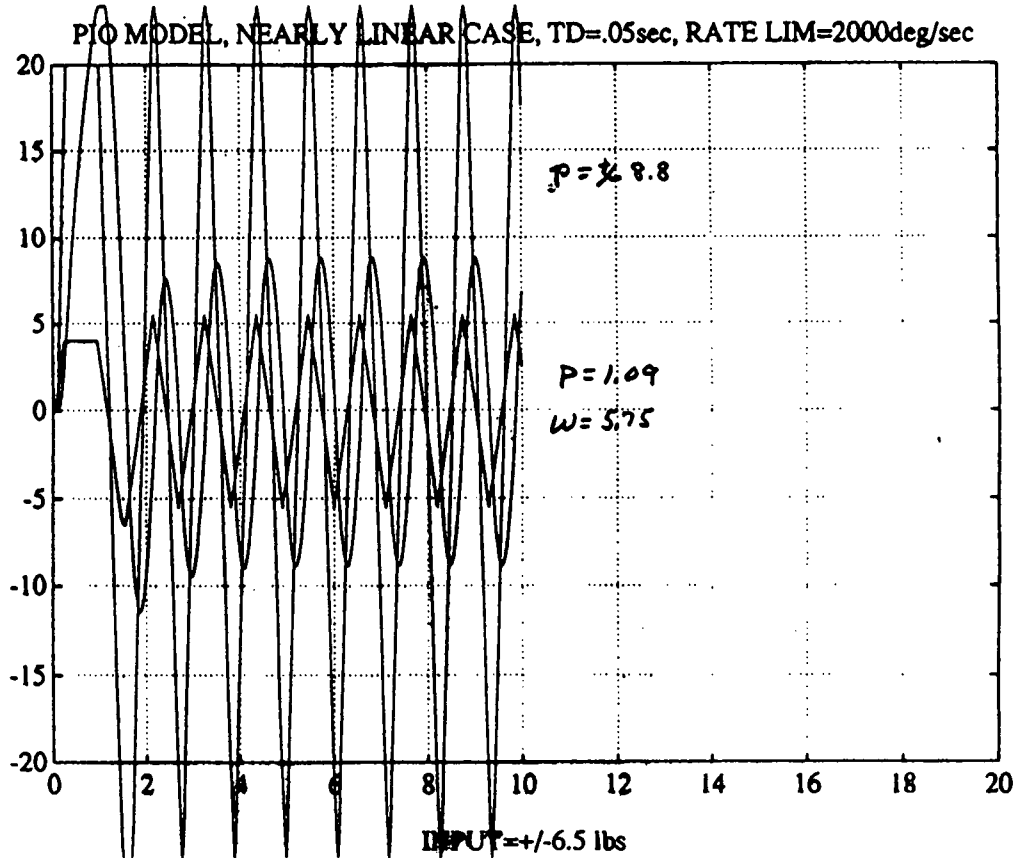

Figure 14

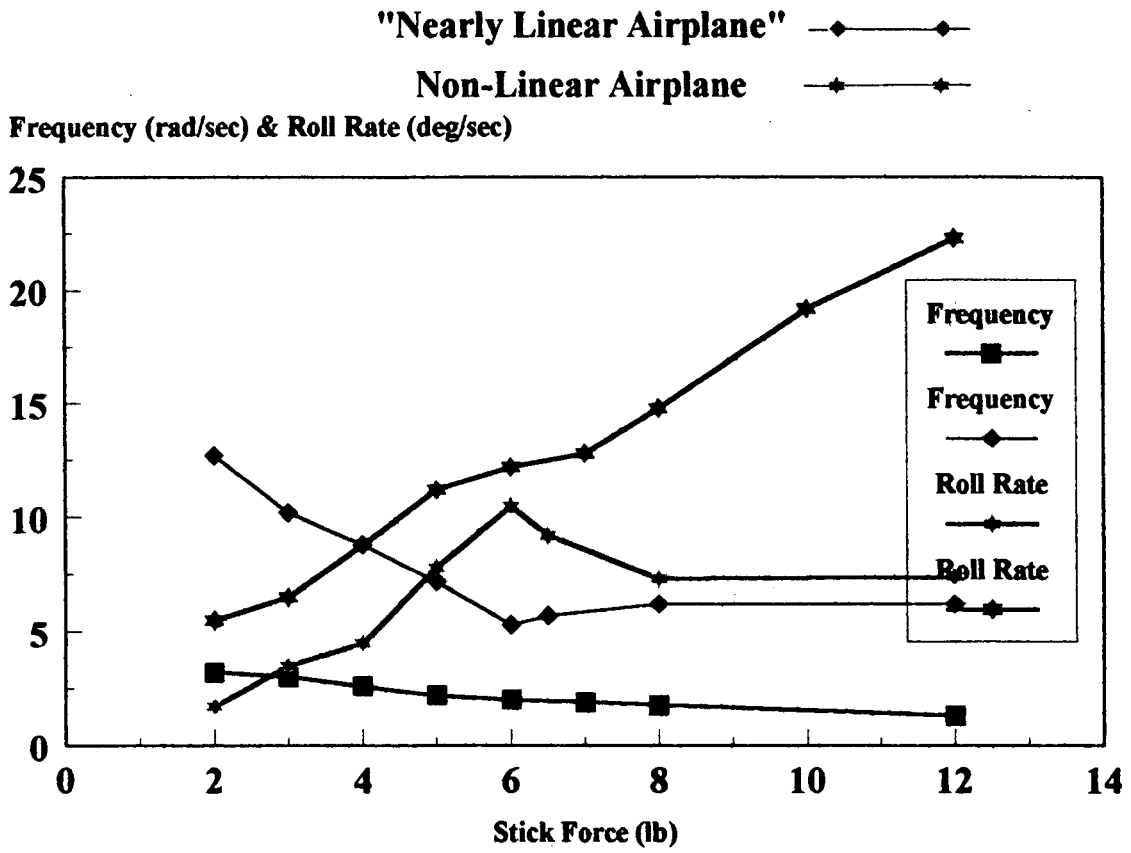

Table I
 Test Conditions

FLT #	LAND #	AXIS	RATE LIMIT (deg/sec)	RLC ON/OFF	RLC KI (deg/deg)	RLC THRESH (deg/sec)	TRANS. DELAY (msec)	CMD GAIN (deg/in)	STICK GRAD. (in/in)
295	1	Roll	20	Off	4	2	90	-25	0.2
	2			On	4	2	90	-25	0.2
	3			On	4	2	90	-25	0.2
	4			On	4	4	90	-25	0.2
	5	Roll	50	Off	6	2	165	-25	0.2
	6			On	6	2	165	-25	0.2
	7			On	6	2	165	-25	0.2
	8			On	6	2	165	-50	0.2
	9			On	6	2	165	-75	0.067
297	1	Pitch	10	Off	4	2	150	-9	0.167
	2			On	4	2	150	-9	0.167
	3			On	4	2	150	-9	0.167
	4	Roll	50	On	6	2	165	-25	0.2
	5			On	0	2	165	-25	0.2
	6	Roll	20	On	4	2	90	-25	0.2
	7			On	4	2	90	-25	0.2
	8			Off	4	2	90	-25	0.2
	9			On	0	2	90	-25	0.2
	10			On	4	2	90	-50	0.2
	11			On	4	2	90	-75	0.067

Table II
 Default Parameters for RLC Algorithm

RATE LIMIT (deg/sec)	THRESHOLD (deg/sec)	KI (deg/deg)
20	2	4
50	2	6

Table III
 Summary of Time Histories Presented in Appendix G

FLIGHT #	RECORD # (Note 1)	AXIS	RATE LIMIT (deg/sec)	RLC ON/OFF	TOUCH-DOWN	PILOT RATING (HQR)	PIO RATING
295	11	Roll	20	Off	No	10	5
295	12	Roll	20	On	Yes	4	2
295	15	Roll	50	Off	Yes	8	4
295	16	Roll	50	On	Yes	5	2
297	6	Pitch	10	Off	Yes	7	4
297	8	Pitch	10	On	Yes	4	2
297	15	Roll	20	On	Yes	4	2
297	19	Roll	20	Off	No	10	5

Note: The full-scale "spikes" on flight 295 time histories are due to inadequate recording scaling of the command signals resulting in occasional saturation of the recorded signals.

REPORT DOCUMENTATION PAGE			
1. Recipient's Reference	2. Originator's Reference AGARD-AR-335	3. Further Reference ISBN 92-836-1013-X	4. Security Classification of Document UNCLASSIFIED/ UNLIMITED
5. Originator Advisory Group for Aerospace Research and Development North Atlantic Treaty Organization 7 rue Ancelle, 92200 Neuilly-sur-Seine, France			
6. Title Workshop on Pilot Induced Oscillations			
7. Prepared at/sponsored by The request of the Flight Vehicle Integration Panel (FVP) of AGARD			
8. Author(s)/Editor(s) Various			9. Date February 1995
10. Author's/Editor's Address Various			11. Pages 128
12. Distribution Statement There are no restrictions on the distribution of this document. Information about the availability of this and other AGARD unclassified publications is given on the back cover.			
13. Keywords/Descriptors			
Aircraft Oscillations Airframes Stability		Flight control Pilots (personnel) Active control	
14. Abstract			
<p>Instability of the pilot/airframe combination has been a problem from the beginning of manned flight. The rapid advances made in aviation following the Second World War greatly increased the incidence of PIO problems and led to a large amount of research and development work aimed at understanding and mitigating these difficulties. Criteria and requirements were developed which could be used in design to obtain satisfactory PIO qualities. Nevertheless, in spite of all this work, and even with the great flexibility in modern control technologies available to the designer, PIO problems still often occur with new aircraft.</p> <p>With current experience, it is clear that a universal solution of the PIO problem still evades the engineering community. The cost of these problems in programme delay and financial terms is significant. The gathering together of specialists to discuss this problem, from their various points of view, has led to positive gains in the state of knowledge regarding PIOs; it has provided a significant step toward their elimination and contributed to the avoidance of PIO associated programme costs and penalties.</p> <p>This report summarizes the presentations and discussions from a Workshop on the subject of PIO, sponsored by the Flight Mechanics Panel of AGARD, and held in conjunction with the Symposium on Active Control Technology, Turin, May 1994.</p>			

2
-
4

AGARD

NATO  OTAN

7 RUE ANCELLE • 92200 NEUILLY-SUR-SEINE

FRANCE

Télécopie (1)47.38.57.99 • Téléc 610 176

DIFFUSION DES PUBLICATIONS

AGARD NON CLASSIFIEES

Aucun stock de publications n'a existé à AGARD. A partir de 1993, AGARD détiendra un stock limité des publications associées aux cycles de conférences et cours spéciaux ainsi que les AGARDographies et les rapports des groupes de travail, organisés et publiés à partir de 1993 inclus. Les demandes de renseignements doivent être adressées à AGARD par lettre ou par fax à l'adresse indiquée ci-dessus. *Veuillez ne pas téléphoner.* La diffusion initiale de toutes les publications de l'AGARD est effectuée auprès des pays membres de l'OTAN par l'intermédiaire des centres de distribution nationaux indiqués ci-dessous. Des exemplaires supplémentaires peuvent parfois être obtenus auprès de ces centres (à l'exception des Etats-Unis). Si vous souhaitez recevoir toutes les publications de l'AGARD, ou simplement celles qui concernent certains Panels, vous pouvez demander à être inclu sur la liste d'envoi de l'un de ces centres. Les publications de l'AGARD sont en vente auprès des agences indiquées ci-dessous, sous forme de photocopie ou de microfiche.

CENTRES DE DIFFUSION NATIONAUX

ALLEMAGNE

Fachinformationszentrum,
 Karlsruhe
 D-76344 Eggenstein-Leopoldshafen 2

BELGIQUE

Coordonnateur AGARD-VSL
 Etat-major de la Force aérienne
 Quartier Reine Elisabeth
 Rue d'Evere, 1140 Bruxelles

CANADA

Directeur, Services d'information scientifique
 Ministère de la Défense nationale
 Ottawa, Ontario K1A 0K2

DANEMARK

Danish Defence Research Establishment
 Ryvangs Allé 1
 P.O. Box 2715
 DK-2100 Copenhagen Ø

ESPAGNE

INTA (AGARD Publications)
 Pintor Rosales 34
 28008 Madrid

ETATS-UNIS

NASA Headquarters
 Code JOB-1
 Washington, D.C. 20546

FRANCE

O.N.E.R.A. (Direction)
 29, Avenue de la Division Leclerc
 92322 Châtillon Cedex

GRECE

Hellenic Air Force
 Air War College
 Scientific and Technical Library
 Dekelia Air Force Base
 Dekelia, Athens TGA 1010

ISLANDE

Director of Aviation
 c/o Flugrad
 Reykjavik

ITALIE

Aeronautica Militare
 Ufficio del Delegato Nazionale all'AGARD
 Aeroporto Pratica di Mare
 00040 Pomezia (Roma)

LUXEMBOURG

Voir Belgique

NORVEGE

Norwegian Defence Research Establishment
 Attn: Biblioteket
 P.O. Box 25
 N-2007 Kjeller

PAYS-BAS

Netherlands Delegation to AGARD
 National Aerospace Laboratory NLR
 P.O. Box 90502
 1006 BM Amsterdam

PORTUGAL

Força Aérea Portuguesa
 Centro de Documentação e Informação
 Alfragide
 2700 Amadora

ROYAUME-UNI

Defence Research Information Centre
 Kentigern House
 65 Brown Street
 Glasgow G2 8EX

TURQUIE

Millî Savunma Başkanlığı (MSB)
 ARGE Dairesi Başkanlığı (MSB)
 06650 Bakanlıklar-Ankara

Le centre de distribution national des Etats-Unis ne détient PAS de stocks des publications de l'AGARD.

D'éventuelles demandes de photocopies doivent être formulées directement auprès du NASA Center for AeroSpace Information (CASI) à l'adresse ci-dessous. Toute notification de changement d'adresse doit être fait également auprès de CASI.

AGENCES DE VENTE

NASA Center for
 AeroSpace Information (CASI)
 800 Elkridge Landing Road
 Linthicum Heights, MD 21090-2934
 Etats-Unis

ESA/Information Retrieval Service
 European Space Agency
 10, rue Mario Nikis
 75015 Paris
 France

The British Library
 Document Supply Division
 Boston Spa, Wetherby
 West Yorkshire LS23 7BQ
 Royaume-Uni

Les demandes de microfiches ou de photocopies de documents AGARD (y compris les demandes faites auprès du CASI) doivent comporter la dénomination AGARD, ainsi que le numéro de série d'AGARD (par exemple AGARD-AG-315). Des informations analogues, telles que le titre et la date de publication sont souhaitables. Veuillez noter qu'il y a lieu de spécifier AGARD-R-nnn et AGARD-AR-nnn lors de la commande des rapports AGARD et des rapports consultatifs AGARD respectivement. Des références bibliographiques complètes ainsi que des résumés des publications AGARD figurent dans les journaux suivants:

Scientific and Technical Aerospace Reports (STAR)
 publié par la NASA Scientific and Technical
 Information Division
 NASA Headquarters (JTT)
 Washington D.C. 20546
 Etats-Unis

Government Reports Announcements and Index (GRA&I)
 publié par le National Technical Information Service
 Springfield
 Virginia 22161
 Etats-Unis
 (accessible également en mode interactif dans la base de
 données bibliographiques en ligne du NTIS, et sur CD-ROM)



NATO  OTAN

7 RUE ANCELLE • 92200 NEUILLY-SUR-SEINE

FRANCE

Telefax (1)47.38.57.99 • Telex 610 176

DISTRIBUTION OF UNCLASSIFIED

AGARD PUBLICATIONS

AGARD holds limited quantities of the publications that accompanied Lecture Series and Special Courses held in 1993 or later, and of AGARDographs and Working Group reports published from 1993 onward. For details, write or send a telefax to the address given above. *Please do not telephone.*

AGARD does not hold stocks of publications that accompanied earlier Lecture Series or Courses or of any other publications. Initial distribution of all AGARD publications is made to NATO nations through the National Distribution Centres listed below. Further copies are sometimes available from these centres (except in the United States). If you have a need to receive all AGARD publications, or just those relating to one or more specific AGARD Panels, they may be willing to include you (or your organisation) on their distribution list. AGARD publications may be purchased from the Sales Agencies listed below, in photocopy or microfiche form.

NATIONAL DISTRIBUTION CENTRES

BELGIUM

Coordonnateur AGARD — VSL
Etat-major de la Force aérienne
Quartier Reine Elisabeth
Rue d'Evere, 1140 Bruxelles

CANADA

Director Scientific Information Services
Dept of National Defence
Ottawa, Ontario K1A 0K2

DENMARK

Danish Defence Research Establishment
Ryvangs Allé 1
P.O. Box 2715
DK-2100 Copenhagen Ø

FRANCE

O.N.E.R.A. (Direction)
29 Avenue de la Division Leclerc
92322 Châtillon Cedex

GERMANY

Fachinformationszentrum
Karlsruhe
D-76344 Eggenstein-Leopoldshafen 2

GREECE

Hellenic Air Force
Air War College
Scientific and Technical Library
Dekelia Air Force Base
Dekelia, Athens TGA 1010

ICELAND

Director of Aviation
c/o Flugrad
Reykjavik

ITALY

Aeronautica Militare
Ufficio del Delegato Nazionale all'AGARD
Aeroporto Pratica di Mare
00040 Pomezia (Roma)

LUXEMBOURG

See Belgium

NETHERLANDS

Netherlands Delegation to AGARD
National Aerospace Laboratory, NLR
P.O. Box 90502
1006 BM Amsterdam

NORWAY

Norwegian Defence Research Establishment
Attn: Biblioteket
P.O. Box 25
N-2007 Kjeller

PORTUGAL

Força Aérea Portuguesa
Centro de Documentação e Informação
Alfragide
2700 Amadora

SPAIN

INTA (AGARD Publications)
Pintor Rosales 34
28008 Madrid

TURKEY

Millî Savunma Başkanlığı (MSB)
ARGE Dairesi Başkanlığı (MSB)
06650 Bakanlıklar-Ankara

UNITED KINGDOM

Defence Research Information Centre
Kentigern House
65 Brown Street
Glasgow G2 8EX

UNITED STATES

NASA Headquarters
Code JOB-1
Washington, D.C. 20546

The United States National Distribution Centre does NOT hold stocks of AGARD publications.

Applications for copies should be made direct to the NASA Center for AeroSpace Information (CASI) at the address below.

Change of address requests should also go to CASI.

SALES AGENCIES

NASA Center for
AeroSpace Information (CASI)
800 Elkridge Landing Road
Linthicum Heights, MD 21090-2934
United States

ESA/Information Retrieval Service
European Space Agency
10, rue Mario Nikis
75015 Paris
France

The British Library
Document Supply Centre
Boston Spa, Wetherby
West Yorkshire LS23 7BQ
United Kingdom

Requests for microfiches or photocopies of AGARD documents (including requests to CASI) should include the word 'AGARD' and the AGARD serial number (for example AGARD-AG-315). Collateral information such as title and publication date is desirable. Note that AGARD Reports and Advisory Reports should be specified as AGARD-R-*nnn* and AGARD-AR-*nnn*, respect

S
P
I
N
W
U



331761++P+UL

Printed by  Group
45 Sacré-Cœur  la K1A 0S7

ISBN 92-836-1013-X