

DTIC FILE COPY

AD-A179 932

AFWAL-TR-86-3105

HIGH-TEMPERATURE TEST TECHNOLOGY

H.A. Hanson and J.J. Casey
Fluidyne Engineering Corporation
5900 Olson Memorial Highway
Minneapolis, MN 55422



DTIC
ELECTE
MAY 05 1987
S D
D

February 1987

Final Report for Period September 1984 - January 1986

Approved for public release; distribution unlimited.

FLIGHT DYNAMICS LABORATORY
AIR FORCE WRIGHT AERONAUTICAL LABORATORIES
AIR FORCE SYSTEMS COMMAND
WRIGHT-PATTERSON AIR FORCE BASE, OHIO 45433-6553

87 4 29 036

NOTICE

When Government drawings, specifications, or other data are used for any purpose other than in connection with a definitely related Government procurement operation, the United States Government thereby incurs no responsibility nor any obligation whatsoever; and the fact that the government may have formulated, furnished, or in any way supplied the said drawings, specifications, or other data, is not to be regarded by implication or otherwise as in any manner licensing the holder or any other person or corporation, or conveying any rights or permission to manufacture use, or sell any patented invention that may in any way be related thereto.

This report has been reviewed by the Office of Public Affairs (ASD/PA) and is releasable to the National Technical Information Service (NTIS). At NTIS, it will be available to the general public, including foreign nations.

This technical report has been reviewed and is approved for publication.

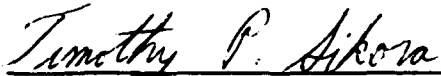
TIMOTHY P. SIKORA
Project Engineer
Project Engineering Group
Structures Test Branch

SANFORD LUSTIG, Chief
Structures Test Branch
Structures Division

FOR THE COMMANDER

HENRY A. BONDARUK, JR., COL, USAF
Chief, Structures Division

If your address has changed, if you wish to be removed from our mailing list, or if the addressee is no longer employed by your organization please notify AFWAL/FIBT, W-PAFB, OH 45433 to help us maintain a current mailing list.

Copies of this report should not be returned unless return is required by security considerations, contractual obligations, or notice on a specific document.

Unclassified

SECURITY CLASSIFICATION OF THIS PAGE

AD-A179 932

REPORT DOCUMENTATION PAGE

1a. REPORT SECURITY CLASSIFICATION Unclassified		1b. RESTRICTIVE MARKINGS	
2a. SECURITY CLASSIFICATION AUTHORITY		3. DISTRIBUTION/AVAILABILITY OF REPORT Approved for public release: Distribution Unlimited	
2b. DECLASSIFICATION/DOWNGRADING SCHEDULE			
4. PERFORMING ORGANIZATION REPORT NUMBER(S)		5. MONITORING ORGANIZATION REPORT NUMBER(S) AFWAL-TR-86-3105	
6a. NAME OF PERFORMING ORGANIZATION Fluidyne Engineering Corp	6b. OFFICE SYMBOL (If applicable)	7a. NAME OF MONITORING ORGANIZATION Structures Test Branch (AFWAL/FIBT) Project Engineering Group	
6c. ADDRESS (City, State and ZIP Code) 5900 Olson Memorial Drive Minneapolis, MN 55422		7b. ADDRESS (City, State and ZIP Code) AFWAL/FIBT Wright-Patterson AFB OH 45433-6553	
8a. NAME OF FUNDING/SPONSORING ORGANIZATION Structures Test Branch	8b. OFFICE SYMBOL (If applicable) AFWAL/FIBT	9. PROCUREMENT INSTRUMENT IDENTIFICATION NUMBER F33615-84-C-3213	
8c. ADDRESS (City, State and ZIP Code) AFWAL/FIBT Wright-Patterson AFB OH 45433-6553		10. SOURCE OF FUNDING NOS.	
		PROGRAM ELEMENT NO. 62201F	PROJECT NO. 2401
		TASK NO. 05	WORK UNIT NO. 24
11. TITLE (Include Security Classification) High-Temperature Test Technology			
12. PERSONAL AUTHOR(S) Hanson, Henry A.; Casey, John J.			
13a. TYPE OF REPORT Final	13b. TIME COVERED FROM Sep 84 TO Jan 86	14. DATE OF REPORT (Yr., Mo., Day) 87 March	15. PAGE COUNT 178
16. SUPPLEMENTARY NOTATION			
17. COSATI CODES		18. SUBJECT TERMS (Continue on reverse if necessary and identify by block number)	
FIELD	GROUP	SUB. GR.	
22	01	Test Facilities, High-Temperature Testing, High-Temperature Test Equipment	
11	07		
19. ABSTRACT (Continue on reverse if necessary and identify by block number) This report describes the findings of a study to determine the state of the art for high-temperature (1000-3000°F) fatigue and static testing of full-scale aerospace vehicle structures and structural components. Facilities, test equipment, instrumentation and test methods currently used by government, industry, and research organizations were surveyed and their capabilities evaluated. The purpose of this survey was to determine what state of the art techniques, equipment, and transducers are available for use in high-temperature structural testing, and to determine if there are any vacuum and cryogenic facilities available which could be adapted for use in high-temperature testing of full-scale aerospace vehicle structures and components containing liquid hydrogen. Recommendations are made for development work in order to establish or enhance the basic capabilities required to meet these needs. <i>Key: 62201F</i>			
20. DISTRIBUTION/AVAILABILITY OF ABSTRACT UNCLASSIFIED/UNLIMITED <input checked="" type="checkbox"/> SAME AS RPT. <input type="checkbox"/> DTIC USERS <input type="checkbox"/>		21. ABSTRACT SECURITY CLASSIFICATION Unclassified	
22a. NAME OF RESPONSIBLE INDIVIDUAL Timothy P. Sikora		22b. TELEPHONE NUMBER (Include Area Code) (513) 255-2318	22c. OFFICE SYMBOL AFWAL/FIBT

FOREWORD

The work documented in this report was performed by Fluidyne Engineering Corporation for the Department of the Air Force, Air Force Wright Aeronautical Laboratories, Flight Dynamics Laboratory, Wright-Patterson Air Force Base, Ohio under Contract F33615-84-C-3213. Air Force Project Engineers were Lt. Charles Waryk and Timothy Sikora of Structures Test Branch, Structures and Dynamics Division. Sanford Lustig, Branch Chief, also provided technical direction. The work was performed in the period from September 1984 through January 1986.

The cooperation of numerous test facilities and equipment suppliers who responded to the survey conducted during the course of this study is gratefully acknowledged.

The authors wish to acknowledge the contributions of Bernard C. Boggs, who served in a consulting capacity providing expertise and assistance in several facets of the program.



Accession For	
NTIS CRA&I	<input checked="" type="checkbox"/>
DTIC TAB	<input type="checkbox"/>
Unannounced	<input type="checkbox"/>
Justification	
By	
Distribution	
Availability Codes	
Dist	Availability For Special
A-1	

TABLE OF CONTENTS

	<u>Page No.</u>
1.0 INTRODUCTION	1
2.0 PROGRAM APPROACH.....	3
2.1 AFWAL Visit to Define High-Temperature Test Facility Requirements.....	3
2.2 Literature Search.....	4
2.3 High-Temperature Measurement Conference.....	4
2.4 Facility and Equipment User Survey.....	5
2.4.1 Facility and Equipment User Screening Contact List.....	5
2.4.2 Facility and Equipment User Screening Survey Questionnaire.....	7
2.4.3 Facility and Equipment Survey Follow-up Contacts.....	8
2.5 Equipment and Instrumentation Supplier Survey Questionnaires.....	9
2.5.1 Survey Questionnaires.....	9
2.5.2 Follow-up Contacts and Visits.....	11
2.6 Consultant	12
3.0 ADVANCED HIGH-TEMPERATURE TEST FACILITY REQUIREMENTS	13
3.1 Advanced Reference Vehicle Definition.....	13
3.2 Test Facility Requirements.....	16
4.0 TECHNOLOGY REVIEW (CURRENT STATE OF THE ART).....	19
4.1 Infrared Radiant Heating Techniques and Equipment.....	19
4.1.1 Radiant Heating Requirements.....	19
4.1.2 Tungsten Filament Quartz Lamps - Equipment User Survey Results.....	21

	<u>Page No.</u>
4.1.3 Tungsten Filament Quartz Lamps - Equipment Supplier Survey Results..	27
4.1.4 Graphite Elements - Equipment User Survey Results.....	30
4.1.5 Graphite Elements - Equipment Supplier Survey Results.....	34
4.1.6 Vortek Heater - Survey Results.....	34
4.1.7 Miscellaneous Heaters Survey Results.....	36
4.2 Structural Loading Techniques and Equipment	37
4.2.1 Structural Loading System Requirements.....	38
4.2.2 Loading System Components - Survey... Results.....	39
Hydraulic System.....	40
Load Control System.....	42
Load and Reaction Fixtures.....	42
4.3 Instrumentation.....	47
4.3.1 Temperature Instrumentation.....	48
4.3.2 Strain Instrumentation.....	54
4.3.3 Deflection Instrumentation.....	66
5.0 ADVANCED HIGH-TEMPERATURE TEST FACILITY BUDGET COST ESTIMATE.....	69
Vacuum System.....	68
Cryogenic System.....	72
Radiant Heating System.....	77
Structural Loading System.....	80
Instrumentation.....	81
Temperature	81
Strain	82
Deflection	82
Load Cells.....	83
Signal Conditioning.....	83

		<u>Page No.</u>
	Signal Conditioner Criteria.....	84
	Preamp Criteria.....	84
	Controller for Signal Conditioner on Preamp Criteria.....	84
	Real Time Processing.....	85
	Computers.....	85
	Electrical Power Substation.....	85
	Water Cooling System.....	87
	Buildings.....	87
	Miscellaneous	94
	Cost Summary.....	94
6.0	GOVERNMENT AND INDUSTRY VACUUM AND CRYOGENIC FACILITIES	95
7.0	CONCLUSIONS AND RECOMMENDATIONS.....	106
7.1	Radiant Heating Test Technology Findings....	106
7.2	Structural Loading Test Technology Findings	108
7.3	Instrumentation Findings.....	109
7.3.1	Temperature.....	109
7.3.2	Strain.....	109
7.3.3	Deflection.....	110
7.4	Vacuum Test Technology and Available Equipment Findings.....	110
7.5	Full-Scale High-Temperature Test Facility - Study Findings.....	111
7.6	Component Test Facility - Study Findings....	113
REFERENCES	114
APPENDIX A	Facility and Equipment Survey Forms.....	A-1
APPENDIX B	Equipment Supplier Survey Forms.....	B-1
APPENDIX C	Vendor Literature.....	C-1
APPENDIX D	Vacuum Chamber Facility Descriptions.....	D-1

LIST OF FIGURES

<u>Figure No.</u>	<u>Title</u>	<u>Page</u>
1	Advanced Reference Vehicle	
2	Peak Reference Vehicle Equilibrium Temperatures (°F)	
3	High-Temperature Structural Test Facility Schematic	

LIST OF TABLES

Table 1	High-Temperature Test Facility Requirements
Table 2	Tungsten Filament Tubular Quartz Lamp Heater Experience
Table 3	Graphite Heater Experience
Table 4	Elevated Surface Temperature Instrumentation - Literature Survey
Table 5	Elevated Surface Temperature Instrumentation - Equipment User and Supplier Survey
Table 6	Results of a Brief Literature Survey of Elevated Temperature Strain Instrumentation
Table 7	Elevated Temperature Static Strain Instrumentation Questionnaire Responses
Table 8	Elevated Temperature Deflection Instrumentation - Equipment User Survey
Table 9	Elevated Temperature Deflection Instrumentation - Suppliers Survey
Table 10	Structural Test Facility Budgetary Cost Estimates
Table 11	Summary of Budgetary Cost Data
Table 12	Government and Industry Facilities with Vacuum and/or Cryogenic Test Capabilities - Survey Results

1.0 INTRODUCTION

The overall objective of this project was to determine the state of the art for high-temperature (1000-3000°F) fatigue and static testing of full-scale aerospace vehicle structures and structural components.

Vehicles are being proposed by the Air Force which will fly significantly higher, farther, and faster than current machines. For example, the proposed Orbit-On-Demand Vehicles (alternately referred to as Transatmospheric Vehicles), which combine space and atmospheric operations, will fly at speeds in excess of Mach 20. Aerodynamic heating from these hypersonic speeds will produce vehicle surface temperatures as high as 3000°F. In many designs, cryogenic fuel tankage represents a large percentage of the total structural weight. Requirements for airframe structural concepts, which will provide structural integrity under the extreme environments associated with these flight regimes and at the same time will not penalize the vehicle from a weight standpoint, are associated with these new designs.

Accurate structural tests with good flight parameter simulation will be required to verify analysis and certify structures for desired mission profiles. With the state of the art of computational structural modeling, it is not possible to assure the safety of aircraft designs without testing.

Close simulation of actual aerodynamic heating/cooling and inertial and aerodynamic loading conditions is important to determine material strength degradation at high temperatures and to determine the effects of thermal gradients in structures. Test conditions should be representative of the flight requirements. Accurate simulation of the loading and the high thermal gradients

imposed by cryogenic fuels will be very important. Cryogenic fuel tank simulation will be needed. Altitude simulation may also be necessary since thermal conductivity of the insulation used on some vehicles is altitude dependent. Instrumentation should measure structure temperatures, strains and deflections induced by boost and entry environments acting on the vehicle which includes an internal liquid hydrogen fuel tank.

To meet this objective, facilities, test equipment, instrumentation, and test methods currently used by government, industry and research organizations were surveyed, and their capabilities were evaluated. The purpose of this survey was to determine what state-of-the-art techniques, equipment and transducers are available for use in high-temperature structural testing, and to determine if there are any vacuum and cryogenic facilities available which could be adapted for use in high-temperature testing of full-scale aerospace and vehicle structures and components containing liquid hydrogen.

The information obtained in the surveys has been evaluated to determine whether Air Force testing needs can be met within the state of the art and to determine budgetary costs for a facility to meet these needs. Finally, recommendations are made for development work in order to establish or enhance the basic capabilities required to meet these needs. We have evaluated the survey data and recommended these which will aid the Air Force in defining structural test facility plans.

2.0 PROGRAM APPROACH

The major task in this study involved conducting a survey to define and evaluate:

- ° State-of-the-art techniques and equipment used by industry, government, and research organizations for testing full-scale structures and components at elevated temperatures.
- ° Modular radiant heater configurations for maximum heat flux for both transient and steady-state conditions.
- ° State-of-the-art transducers and techniques (including methods for attachment of transducers to aerospace materials, and limitations of those methods) used by industry, research organizations, and government for measurement of temperature, strain, and deflection at temperatures from 1000-3000 °F.
- ° Government and industry cryogenic and vacuum facilities which could be adapted to high-temperature testing of full-scale aerospace vehicles and vehicle components containing liquid hydrogen.

2.1 AFWAL Visit to Define High-Temperature Test Facility Requirements

Early in the program, we made a visit to the AFWAL Flight Dynamics Laboratory, Structural Test Branch, to discuss the expected requirements for high temperature structural test work to be done by AFWAL and other Air Force programs. The Air Force requirements established in this meeting helped form a basis for

evaluating the facilities, equipment, and transducers identified in the surveys.

For cost evaluation and comparison purposes, a Reference Test Vehicle was selected. Test facility requirements were also defined based on Reference Vehicle test requirements.

2.2 Literature Search

We made brief literature search in order to determine the locations where information relative to the state of the art of high-temperature test equipment, test methods, measurement techniques, and transducers could be best located. We used information from the literature in developing the survey questionnaires and contact lists.

A brief determination of the probable structural materials of future aerospace vehicles was made prior to conducting the transducer and measurement technique survey. The appropriate ranges over which temperature, strain, and deflection are to be measured and possible restrictions on transducer output were also investigated.

2.3 High-Temperature Measurement Conference

In March 1985, FluidDyne members engaged in this project attended the Conference on High-Temperature Measurements for Experimental Mechanics held in Knoxville, Tennessee. Most of the papers presented were on high-temperature strain measurements and included both optical and strain gage techniques. Much of the work described was developmental in nature but a good deal of the strain gage papers covered installation and calibration. Topics included gage materials, apparent strain, drift, gage factor variation with temperature, and lead wire types and connec-

tions. A number of papers described test specimen surface preparation in considerable detail. Organizations represented included nuclear, metals processing and aerospace, especially those concerned with aircraft engine development.

2.4 Facility and Equipment User Survey

2.4.1 Facility and Equipment User Screening Contact List

The first step in the survey process involved compiling a preliminary list of test technique and equipment information sources to be contacted. FluidDyne contacts, AFWAL personnel, Bernard Boggs (consultant), computer literature searches, Air Force references, NASA/Aerospace references, and other sources were used in developing the initial screening contact list.

We made telephone contacts with most organizations prior to mailing questionnaires to identify specific personnel with necessary information, to obtain proper addresses, and for establishing cooperative relationships.

We updated the contact list continually to add sources that were identified through contacts made during the course of the survey.

The following government and industry aerodynamic structure testing facilities were contacted.

Government Facilities

Air Force Rocket Propulsion Lab.....	Edwards AFB, CA
Arnold Engineering Development Center.....	Tullahoma, TN
NASA-Ames Research Center.....	Moffett Field, CA
NASA-Dryden Flight Research Facility.....	Edwards AFB, CA

NASA-Mashall Space Flight Center.....	Huntsville, AL
NASA-Jet Propulsion Lab.....	Pasadena, CA
NASA-Johnson Space Center.....	Houston, TX
NASA-Johnson Space Flight Center..... White Sands Test Facility	Las Cruces, NM
NASA-Kennedy Space Center.....	FL
NASA-Langley Research Center.....	Hampton, VA
NASA-Lewis Research Center.....	Cleveland, OH
NASA-Lewis Research Center..... Plum Brook Station	Sandusky, OH
Vandenberg AFB	VAFB, CA
Air Force Wright Aeronautical Laboratories... Flight Dynamics Lab	WPAFB, OH

Industrial Facilities

Aerojet Solid Propulsion Company.....	Sacramento, CA
AiResearch Mfg. Co. of California.....	Los Angeles, CA
Boeing Aerospace Company.....	Seattle, WA
Douglas Aircraft Company.....	Long Beach, CA
Grumman Aerospace Corporation.....	Bethpage, NY
General Dynamics Corporation..... Ft Worth Division	Ft Worth, TX
General Dynamics Corporation..... Convair Division	San Diego, CA
Lockheed Corporation.....	Burbank, CA
The LTV Corporation.....	Dallas, TX
Martin Marietta Corporation..... Denver Division	Denver, CO
Martin Marietta Corporation..... Orlando Division	Orlando, FL
McDonnell Aircraft Company.....	St. Louis, MO
McDonnell Douglas Astronautics.....	Huntington Beach, CA
Rockwell International Corp.....	Downey, CA
Rockwell International Corp.....	El Segundo, CA

Rockwell International Corp..... Seal Beach, CA
Sandia National Laboratory..... Albuquerque, NM

Sources contacted were limited to domestic only. No foreign facilities were contacted.

2.4.2 Facility and Equipment User Screening Survey Questionnaires

We took special care in preparing the survey data forms to assure getting back a high percentage of questionnaires mailed. Recommendations were obtained from References 1 and 2 regarding questionnaire layout and format and general pitfalls to be avoided. Each questionnaire was accompanied by: (1) a letter of transmittal describing the program and outlining the purpose of the survey and the data and information needed; and (2) a letter from Colonel Roger J. Hegstrom urging cooperation in the survey. (See Appendix A.)

The screening questionnaire, entitled High-Temperature Structural Test Facilities Questionnaire, (see Appendix A) was used for the majority of the facility and equipment user contacts. The questionnaire was kept brief and easy to fill out to encourage response. The information requested was very limited, intended principally to determine if the facility, equipment, and/or instrumentation had sufficient desired capability to warrant further consideration.

An alternate questionnaire, entitled Cryogenic Test Facility Questionnaire, (see Appendix A) was mailed to organizations known to have cryogenic capabilities. The information requested was more comprehensive and detailed.

Response to the facility and equipment user screening survey was excellent. Responses were received from 29 of the 31 sources contacted. Organizations proved to be very willing to cooperate.

Because of busy schedules, personnel changes, vacations, and the fact that questionnaires were not always sent to the person or persons in the organization with the necessary information, follow-up contact work was required.

2.4.3 Facility and Equipment Survey Follow-up Contacts

We made follow-up telephone contacts with those sources found useful and willing to cooperate in the initial screening contacts. Because of the large number of potential information sources and the limited budget, we made follow-up contacts by telephone. This proved to be a very satisfactory and cost effective method for determining the state-of-the-art technology and general facility capabilities. We made a facility visit to the AFWAL Flight Dynamics Laboratory.

Key elements of the survey and evaluation efforts regarding fatigue and static loading system test techniques and equipment included mechanical loading system types, maximum test specimen temperature, methods for attachment of the loading systems to the test article surface, methods for thermal protection of structural test system components, and controls for loading systems. The key elements of the survey and evaluation efforts regarding modular radiant heater equipment were maximum heat flux capability, maximum attainable test specimen temperature, heater life, module cooling designs and heating element control methods. The information obtained from the survey included capabilities and limitations of the testing methods and techniques.

The key elements of the survey and evaluation efforts regarding transducers and measurement techniques included suitability of transducers for the range of test conditions, methods and limitations for attachment of transducers and cabling and protection from excessive heat. The information obtained from the survey included capabilities, limitations, and availability of the instrumentation.

The survey also included a determination of potential government and industry cryogenic and/or vacuum facilities which could be adaptable for high temperature structural testing of full-scale aerospace vehicles and vehicle components containing liquid hydrogen. The survey was focused on determining whether a given facility had the necessary cryogenics, vacuum, and electrical power systems, the capabilities of the systems if they so exist, and the feasibility of adding the needed systems if they do not exist. In addition to cryogenic and vacuum capabilities, the facility must have or be capable of adding sufficient electrical power.

We sent follow-up questionnaire forms, requesting detailed information about equipment capabilities and test experience, were sent to organizations found to have special experience and information to offer regarding high-temperature structural testing (see Appendix A).

2.5 Equipment and Instrumentation Supplier Survey

2.5.1 Survey Questionnaires

Major vendors of testing equipment and measurement transducers were also surveyed to determine the capabilities and costs of equipment suitable for the high-temperature test requirements.

Research organizations with special instrumentation expertise were also included in the survey. The list of equipment transducer and measurement technique information sources to which surveys were mailed is presented below.

Radiant Heating Suppliers

Research Inc.	Eden Prairie, MN
Fostoria Corporation.....	Fostoria, OH
Lux Therm Products	Torrance, CA
Vortek Industries Ltd.....	Vancouver, BC

Strain Instrumentation Suppliers and Developers

Comtel Midwest Co.	Minnetonka, MN
Hitec Corporation	Westford, MA
Willard Pearce Associates.....	Allison Park, PA
Babcock & Wilcox,	Columbus, OH
Research & Development Div.	
Battelle Columbus Laboratories.....	Columbus, OH
McDonnell Douglas	St. Louis, MO
United Technologies Research Center.....	East Hartford, CT
Paul Beckman Company.....	Elkins Park, PA

Deflection Sensor Equipment Suppliers

Bentley Nevada Corporation.....	Minden, NY
Allen-Bradley Company.....	El Paso, TX
Celesco Transducer Products.....	Canoga Park, CA
Gould Inc. Measurement Systems Div.....	Oxnard, CA
Hitec Corporation	Westford, MA
Hottinger Baldwin Measurements Inc.....	Framingham, MA
MTS Systems Corporation.....	Minneapolis, MN
Schaevitz Engineering.....	Pennsauken, NJ

Temperature Instrumentation Suppliers

Omega Engineering Inc.....	Samford, CT
Driver-Harris Company.....	Harrison, NJ
Alnor Instrument Company.....	Skokie, IL
Paul Beckman Company.....	Elkins Park, PA

We developed four different survey forms, appropriate to the various types of equipment and instrumentation being surveyed. These forms include: (see Appendix B)

- Infrared Radiant Heating Equipment Supplier Questionnaire.
- High-Temperature Strain Instrumentation Supplier Questionnaire.
- High-Temperature Displacement Sensor Supplier Questionnaire.
- High Surface Temperature Instrumentation Supplier Questionnaire.

The information requested in these surveys included high-temperature capabilities, limitations, costs, and commercial availability of equipment and instrumentation.

2.5.2 Follow-Up Contacts and Visits

Follow-up telephone contacts were made with those sources found useful and willing to cooperate in the initial screening contacts.

Visits were made to Research, Inc., the major supplier of infra-red heating equipment for structural testing. Research, Inc. has provided radiant heating systems for NASA/Langley, NASA/Houston, NASA/Huntsville, Wright Patterson AFB, Boeing, and many other aircraft companies.

A visit was made to MTS Systems Corporation, a supplier of automatic programmable structural loading systems.

2.6 Consultant (Bernard C. Boggs)

Mr. Bernard C. Boggs served in a consulting capacity providing expertise and assistance in several facets of the program. Contributions included assisting in the interpretation of facility requirements; assisting with the development of facility layout and cost information; recommending additional information sources; and reviewing survey forms.

Mr. Boggs has extensive experience in structural test engineering. At WPAFB he was involved in the planning, developing and implementing of major facility modification and construction programs to support the exploratory and advanced development structural test programs conducted by the Experimental Branch, Structures Division, Flight Dynamics Laboratory. He was responsible for the operation, maintenance and modernization of all electrical, cryogenic, load application, hydraulic and pneumatic systems and associated electronic controls as well as for all facility modifications to meet future requirements. He was involved in the development of new techniques and procedures for environmental simulation and control.

3.0 ADVANCED HIGH-TEMPERATURE TEST FACILITY REQUIREMENTS

3.1 Advanced Reference Vehicle Definition

The proposed high-temperature test facility would have the capability for accommodating a wide range of future test programs requiring elevated temperature, altitude (vacuum) and/or cryogenic simulation. It is not possible at this time to define the full range of test structures to be tested. Many of the programs and test vehicles are yet to be designed.

The supersonic Transatmospheric Vehicles (TAV's) are examples of future vehicle concepts with special high-temperature structural test requirements. Fuel and oxidizer tankage represents a major portion of vehicle weight. High performance thermal insulations are required to accommodate the large temperature gradients associated with storage of hydrogen at -423°F and aerodynamic heating of outer surfaces to temperatures as high as $+3000^{\circ}\text{F}$.

For purposes of defining typical test facility requirements, the "Baseline Vehicle" used in Reference 3 (page 3-6) for formulation and evaluation of structural concepts for hot structure integral cryogenic tankage was selected as a Reference Vehicle. This selection was made by Air Force personnel in a meeting at WPAFB. Design data for the delta winged, rocket powered vehicle, which uses an all metallic integral fuel tank airframe system, are presented in Figure 1. Peak equilibrium isotherms are shown in Figure 2. Test requirements are thought to be typical of future hypersonic vehicles.

Test materials described in Reference 3 were also defined as typical. We subsequently decided to use these as a basis for defining attachment requirements.

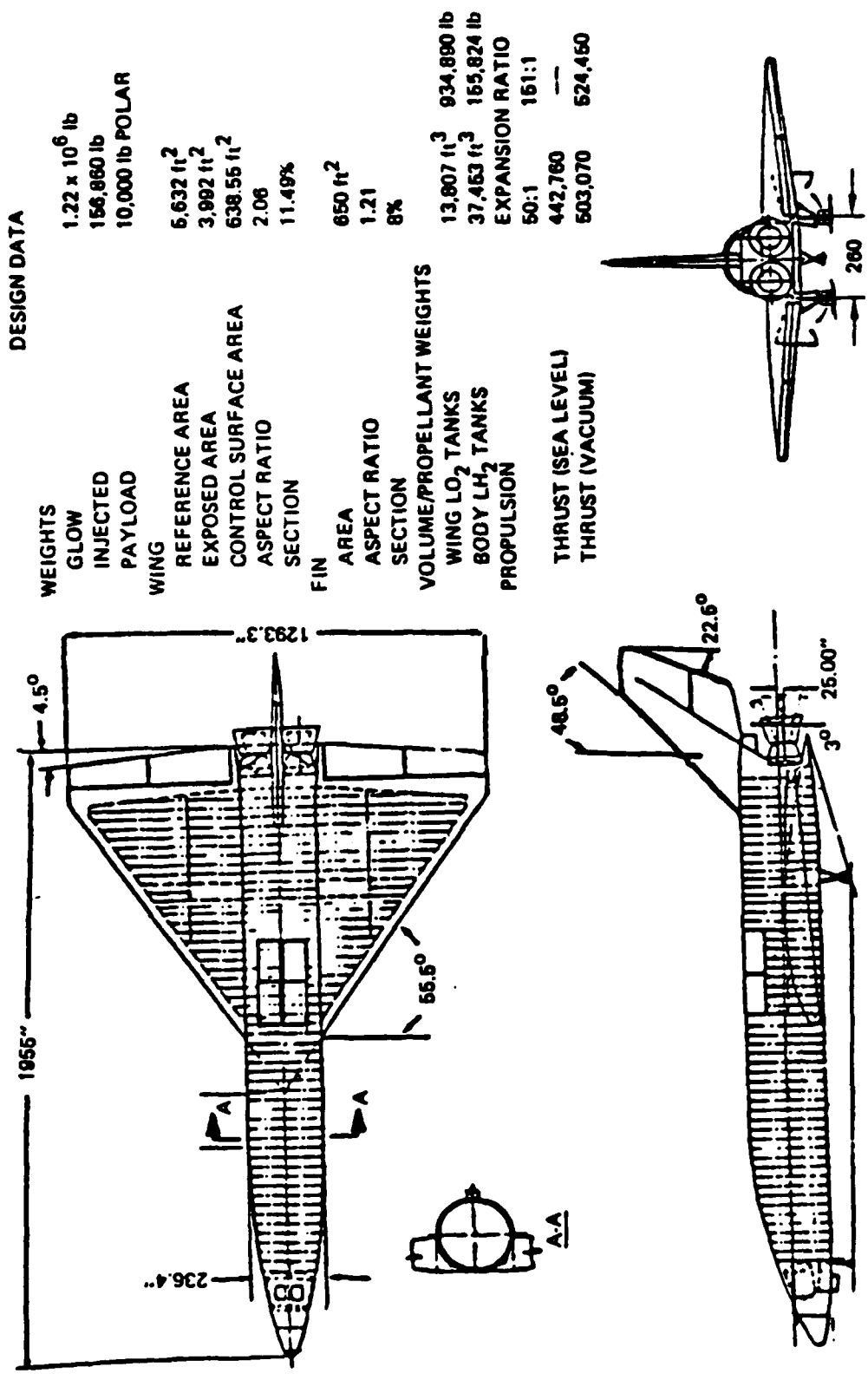

FIGURE 1. ADVANCED REFERENCE VEHICLE
(Reference 3)

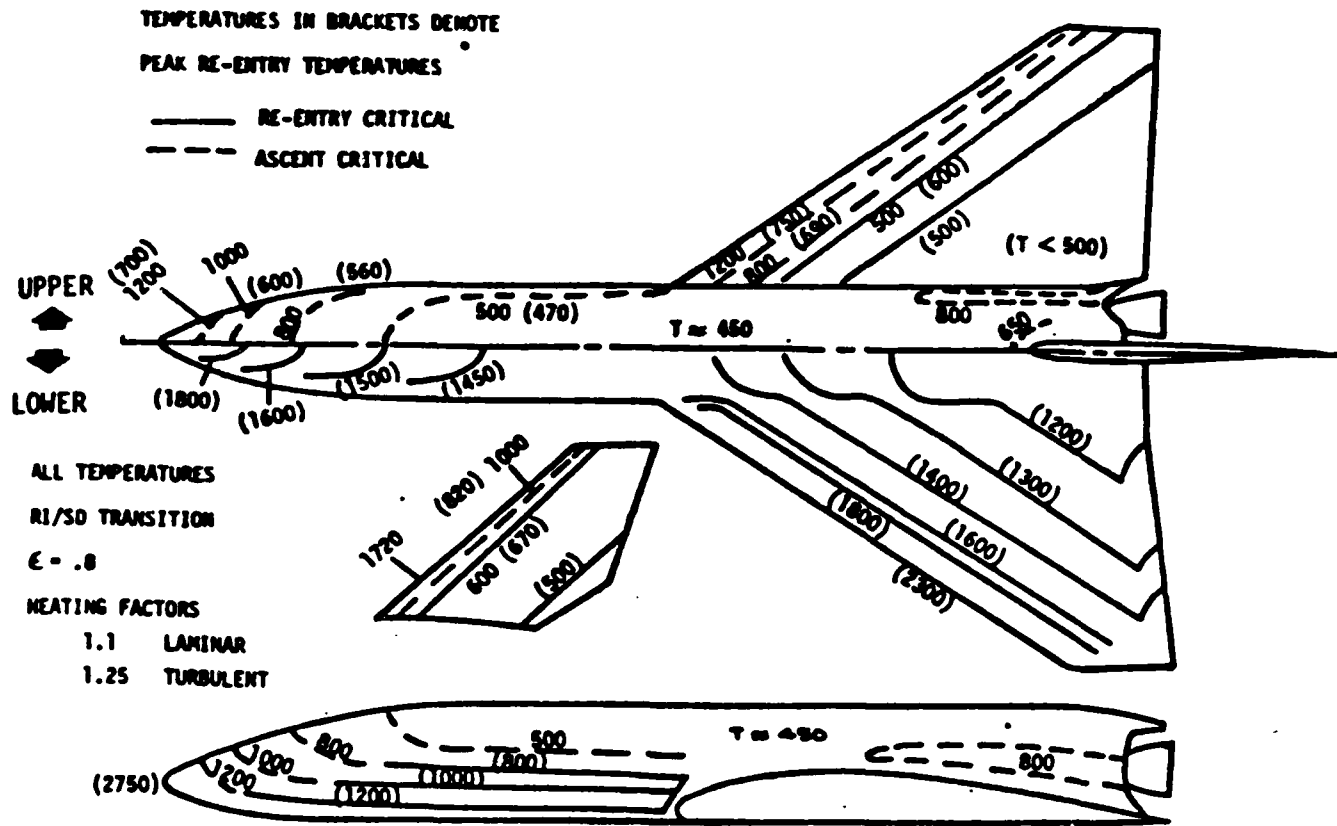

FIGURE 2. PEAK BASELINE VEHICLE EQUILIBRIUM TEMPERATURES ($^{\circ}$ F) -
 TRAJECTORY 180

(Reference 3)

3.2 Test Facility Requirements

Test facility requirements are summarized in Table 1. These represent minimum requirements to test the structural integrity of the Reference Vehicle and certify it for a typical mission profile. These requirements are assumed to be typical of those necessary to meet future Air Force needs.

Two different size test chambers were considered. The larger, a horizontal vessel (100 ft diameter x 150 ft long), would be used for structural verification of the complete delta wing or a major portion of the fuselage. The smaller test chamber (30 ft diameter x 60 ft long) would be used primarily for testing a portion of the wing or a significant length of fuselage.

Both proposed facilities would have vacuum capabilities for altitude simulation, cryogenic systems (liquid hydrogen and nitrogen) for fuel temperature and load simulation, radiant heating for elevated temperature (aerodynamic heating) simulation, and a structural loading system for aerodynamic and inertial load simulation. Static and fatigue testing could be done in the same chamber at different times. The facilities would be capable of simulating flight parameters associated with high speed flight.

The facilities would be capable of meeting new complex technical requirements for studying new flight structures. They would be capable of meeting the new challenges resulting from hypersonic cryogenic fueled vehicles with advanced structural materials.

TABLE 1. HIGH-TEMPERATURE TEST FACILITY REQUIREMENTS

Item	Full-Scale Test Facility		Component Test Facility	
	Requirement	Source	Requirement	Source
1. Test Chamber Size	100 ft dia x 150 ft long	AF	30 ft dia x 60 ft long	Air Force (AF)
2. Heating				
◦ Maximum Vehicle Surface Temp.	3000 F	AF	3000 F	AF
◦ Vehicle Surface Area	100 ft x 100 ft	AF	1200 ft ²	FluIDyne (FD)
◦ Maximum Power Requirements	350 MW*	FD	45 MW	FD
◦ Number of Heater Control Panels (Areas 4 ft x 4 ft)	700	AF	84	FD
◦ Maximum Temp. Rise Rate	20 F/sec	AF	20 F/sec	AF
◦ Required Number of Temp. Sensors	4000	AF	480	FD
3. Loading				
◦ Maximum Vehicle Weight	1.2 x 10 ⁶ lbs	AF	100,000 lbs	FD
◦ Maximum Vehicle Load	3 x 10 ⁶ lbs vertical 443,000 lbs axial	AF	250,000 lbs vertical 300,000 lbs axial	FD
◦ Maximum Tail Load (Yaw)	assume negligible		assume negligible	FD
◦ Number of Load Control Channels (1 every 50 sq ft)	200	AF	50	FD
◦ Number of Deflection Sensors Required	100	AF	12	FD

* 175 MW delivered to surface

TABLE 1. HIGH-TEMPERATURE TEST FACILITY REQUIREMENTS (continued)

Item	Full-Scale Test Facility		Component Test Facility	
	Requirement	Source	Requirement	Source
° Maximum Deflection	3 feet	FD	3 feet	FD
° Number of Strain Gages	2000	AF	240	FD
Requirements				
° Maximum Strain (microstrains)	5000	FD	5000	FD
° Required gal/min Hydraulic Fluid	1000	FD	250	FD
4. Chamber Press Requirements				
° Maximum	+25 psig	AF	+25 psig	AF
° Minimum	1 x 10 ⁻⁶ torr	AF	1 x 10 ⁻⁶ Torr	AF
5. Cryogenics				
° LH ₂ Storage	560,000 gal	AF	225,000 gal	FD
° LN ₂ Storage	300,000 gal	AF	30,000 gal	FD
° Maximum Flow Rate of LH ₂	33,000 gpm	FD	13,000 gpm	FD
° Maximum Flow Rate of LN ₂	12,509 gpm	FD	1,300 gpm	FD
6. Safety Requirements				
° Distance	500 ft	AF	500 ft	AF
° Barrier	Height = 80 ft	AF	Height=80 ft	AF

4.0 TECHNOLOGY REVIEW (CURRENT STATE OF THE ART)

4.1 Infrared Radiant Heating Techniques and Equipment

An important objective of this study was to identify the state of the art techniques and equipment for heating full-scale aerospace vehicle structures to temperatures as high as 3000°F. The investigation was limited to modular radiant heater configurations. Study of solar, chemical, convective and inductive techniques was not within the scope of the program.

Radiant heating, with an electrical resistance type heat source, is and has been the most widely used heating method for thermostructural testing. Electrical heating affords the advantage of being able to provide large amounts of energy on demand without a large storage capacity. Its simplicity of control and the fact that any number of individual heating zones can be designed to provide different temperature profiles is in major part responsible for its popularity. Power control can be regulated to provide any precise temperature using thermocouples for temperature measurement and feedback in a control zone. Like aerodynamic heating, radiant heating is a surface heating phenomenon, hence it can produce excellent simulation.

4.1.1 Radiant Heating Requirements

The following basic heater criteria are required for full-scale elevated temperature thermostructural testing:

- ° Suitability for heating large, sometimes complex shaped, test vehicle surface areas to high temperatures (1000 - 3000°F). Full-scale aerospace vehicles may have as much as 10,000 sq ft of surface area to be heated.

- ° Ability to duplicate temperature as a function of time throughout a flight mission profile. Capability for automatic programmable closed-loop multiple zone temperature control. Full scale aerospace vehicles may require as many as 700 independent control channels.
- ° Sufficient heat flux density to produce test vehicle surface temperature rise rates up to 20°F per second.
- ° Ability to operate in vacuum (pressures as low as 10^{-6} torr). Altitude simulation is required for some thermal protection systems.
- ° Reasonably compact. The space available within the vacuum test chamber will be small and crowded with loading connections and other instrumentation.
- ° Reasonable lamp life at the maximum temperature at which testing is intended. Typical vehicle mission to be simulated may be a few hours long.
- ° Reasonable cost. Although the cost of a single module may not be large, a great many modules may ultimately be required.
- ° Since there will be hydrogen in the test vehicle, air cooling of equipment must be avoided. Closed water systems and inert gases such as nitrogen are acceptable.

4.1.2 Tungsten Filament Quartz Lamps - Equipment User Survey Results

The structural test facility and equipment user questionnaire (see Appendix A) sent to industry, and government facilities requested information regarding radiant heating state-of-the-art techniques and equipment used. The information solicited included types of application, types of lamps and heaters, as well as highest test specimen temperature levels achieved. This served as a screening survey, identifying sources with potentially useful information. Additional information was then obtained through follow-up questionnaires or follow-up telephone contacts.

Based on questionnaire responses, radiant heating with T-3 tungsten quartz lamps is the most popular method employed for high-temperature thermostructural testing.

T-3 tungsten filament quartz lamps are available commercially in lengths from 10 inches to 38 inches depending on voltage. They consist of a small diameter spiral coil shaped tungsten filament encased in a sealed 3/8-inch-diameter quartz tube filled with inert gas to protect the tungsten from oxidation. The tungsten filament can be heated to about 5400°F. The surrounding quartz tube, however, must be externally cooled (typically by blowing gas across the quartz surface) to below 2500°F to maintain structural stability. End seals must be cooled to about 650°F or lower to limit oxidation.

A detail description of tungsten quartz lamps and their operating characteristics is provided in Reference 4. Typical commercial heater assemblies are described in Section 4.1.3 of this report.

Survey information regarding high temperature infrared tungsten quartz lamp test experience and capabilities is summarized in Table 2. The survey results suggest that there has been little change in the state of the art in the last 20 years.

Most of the very high-temperature applications (above 2500°F) were material tests where the specimen heated area was very small, typically less than a few square feet. There were no large scale/long term structural tests reported above 2500°F. In fact, most of the larger applications were at temperatures below 2000°F. Lamp cooling was reported to be the major obstacle for very high heating rates and high equilibrium temperatures. It is difficult to get enough cooling gas flow for the quartz tube and end seals for high rates of heat dissipation.

The general consensus from the surveys is that the maximum practical power density from tungsten quartz lamps is about 150-175 Btu/sq ft-sec. For special short term applications, 200 Btu/sq ft-sec can reportedly be obtained.

NASA Marshall Space Flight Center reported heating 400 sq ft of test specimen to temperature levels ranging from 1200°F to 2500°F. This is the largest high-temperature application reported with tungsten quartz lamps.

NASA Dryden Flight Research Facility reported heating 170 sq ft of specimen area to temperatures in the range 1000-2000°F. It is currently testing a hypersonic (Mach 8) wing structure at temperatures up to 1900°F. They also reported having ordered a new updated radiant heating system designed for 2500°F with heat rates to 150 Btu/sq ft-sec to be controlled to +10°F. Teledyne is providing the control system and Research Inc. is supplying the heater system. It intends to explore the envelope of quartz lamp testing for vehicle structural testing.

TABLE 2. TUNGSTEN FILAMENT TUBULAR QUARTZ LAMP HEATER EXPERIENCE

	Max. Temp.	Max. Temp. Operating Experience	Lower Temp. Operating Experience			
User	Temp.	Spec. Size	Application	Max. Temp.	Spec. Size	Application
1. AEDC	1200°F	few ft ²	Spacecraft Thermal Testing			Small solar simulator
2. Rockwell (El Segundo)	1800°F					
3. Grumman	1000°F	6 ft x 6 ft	Aircraft Structural			
4. Sandia Rad Heat Fac.	3000°F	Small	Thermo-Structural	1200°F	200 ft ²	Solar Receiver
5. Boeing	3000°F	Small Furnace	Material Tests	2000°F	Large Vehicle Areas	Dyna Soar Program
6. McDonnell St Louis	2000°F+	Small		1800°F	Large	Gemini Program
7. NASA* (Dryden)	2600°F	6 Ft ²	Structural Testing	1900°F	Large	Hypersonic Wing Struct. 170 ft ² largest specimen area 1000-2000°F)
8. LTV	2000°F		Structural Testing			No work in vacuum

* Ordered new system capable of heating large surfaces to 2500°F with heat rates to 150 Btu/ft²-sec and with control to ± 10°F.

TABLE 2. (Continued)

	Max. Temp.	Max. Temp. Operating Experience	Lower Temp. Operating Experience	Comments
User	Temp.	Spec. Size	Spec. Size	Application
9. General Dynamics (Ft Worth)	600°F			Structural Testing
10. Lockheed (Rye Canyon)	1800°F	Small		Materials Study
11. AiResearch	200°F			Space Simulations
12. WPAFB	3000°F	70 ft ²		Thermantic Structure
13. NASA (Langley)	1800°F	Small		
14. Rockwell (Downey, CA)	1600°F			Space Shuttle Structural Components
15. NASA Marshall	1200 - 2500°F	400 ft ²		Shuttle Orbiter Structural Thermal Testing
16. McDonnell (Huntington Beach)				12.5 megawatts lamp power

Very limited experience was reported with vacuum conditions. Some test work has been done in soft vacuums with tungsten quartz lamps but not routinely. Users reported experiencing problems with electrical arcing as pressure is reduce to the 1-to-0.1-torr level. Breakdown is a function of the product of pressure level and electrical gap lengths. Fixture damage is common. No large scale testing in a vacuum was reported. Very little experience was reported with hard vacuums (10^{-6} torr). Sandia indicated that when operating in a vacuum, it typically operates with much lower power densities than in air.

Extensive automatic, programmable, closed-loop, multiple zone temperature control experience was reported. Silicon controlled rectifiers (SCR's) have replaced ignitron mercury-arc type rectifiers. State-of-the-art control would appear to be adequate for the high-temperature test facility.

Some of the more important reasons given by users for choosing and preferring tungsten quartz lamps are summarized below.

- ° Rapid dynamic response compared with graphite elements which are more massive.
- ° Tungsten quartz lamps are less susceptible to oxidation than graphite elements.
- ° Commercially available hardware.
- ° Tungsten elements dissolve on failure, whereas graphite elements can short and spark to ground, subsequently creating safety and test setup damage problems.

Problems and limitations (associated with tungsten quartz lamps) reported by equipment users include:

- ° Maximum lamp power density output for large scale applications requiring long lamp life limited to about 150-175 Btu/sq ft-sec. Basic limitation is the number of elements that can be packed into a given area while still keeping the lamp end seals from overheating. The maximum heat flux density to a test specimen is about 100 Btu/sq ft-sec. The maximum efficiency (heat to specimen) with a tungsten quartz lamp configuration is in the range of 50-70%.
- ° End seal oxidation and high-temperature failure of the quartz tube limits the maximum specimen temperature. Cooling the quartz envelope and end seals is difficult with very high-temperature operation. The lamps droop and darken when operated hot.
- ° Cooling of the lamps in a vacuum is difficult. Air cooling cannot be done if the test specimen contains hydrogen.
- ° Electrical arcing is a problem in a vacuum. As the pressure level is decreased, the potential for corona and breakdown is increased.
- ° Specimen outgassing. When heating carbon-carbon test specimens, quartz lamps become dirty and tend to heat up.

4.1.3 Tungsten Filament Quartz Lamps - Equipment Supplier Survey Results

In addition to radiant heating equipment users, equipment suppliers were also surveyed. Survey information included advertised capabilities, commercial availability, state-of-the-art techniques, field operating experience, and equipment costs. Solicited information included lamp hardware, reflector configurations, cooling configurations, maximum flux density, maximum specimen temperature experience, costs, operating experience, etc.

The survey verified a suspicion that there are currently few commercial suppliers of high-temperature tungsten quartz radiant heating equipment for large-scale aerothermal structural testing. Twenty years ago, during a period when hypersonic vehicle development work flourished, there were several commercial suppliers offering various types of tungsten quartz lamp holders and reflector systems. Equipment and capabilities offered during this time period are described in Reference 4.

A decline in the heater demand has brought with it a decrease in the number of commercial offerings. We believe that two former suppliers, Pyro-Metrics and Lunar Infrared, are no longer in business. In addition, the Hi-Shear product line is now marketed by Lux Therm Products.

Fostoria Corporation:

Fostoria Corporation reports that they have concentrated attention on lower temperature infrared heating equipment in recent years. Their current commercial infrared heater offerings are all air-cooled, hence maximum specimen temperatures are

limited to 900-1000°F. They are reportedly, not actively pursuing higher temperature radiant heating applications where water-cooled reflectors are required.

In the late sixties Fostoria supplied a water-cooled heater configuration to Wright-Patterson AFB for heating a nose cone. Tungsten lamps were arranged on 3/4-inch centers. This system was capable of heating the nose cone to approximately 2100°F.

Lux Therm

Lux Therm offers radiant heaters with T-3 lamps. We were unable to obtain additional technical information regarding performance and capabilities.

Research Incorporated

Research Inc. has provided systems to various NASA facilities (Langley, Huntsville, Houston, etc.), Wright-Patterson AFB, Boeing, McDonnell Douglas, and other aircraft suppliers. They continue to offer a commercial line of water-cooled high-temperature tungsten quartz radiant heaters (see Appendix C -- Data Bulletin D518.1B.)

Research Inc. proposes that 2500°F be considered a practical upper-test specimen temperature limit with tungsten quartz lamps for large scale structural test applications where high-heat fluxes and long lamp life are required. They further propose that the maximum practical absorbed test specimen heat flux density for long term periods is about 100 Btu/sq ft-sec. Higher levels have been demonstrated, but only on very small areas and with very short lamp life.

A gas-cooled lamp and water-cooled reflector configuration is recommended for the desired high-temperature structural test application. Air-cooled reflectors are recommended only for low temperature and low-heat flux applications. Ceramic reflectors are not recommended by Research Inc. for high-heat flux densities. Ceramic is a poor reflector and can also break down under high-heat flux. For high reflectance, specular metals are required. Aluminum is recommended. Copper is less desirable because it will tarnish. Stainless steel is not recommended because it is a poor reflector and also will tarnish. Gold plating can be utilized if higher reflectance is required.

For the desired application, Research Inc. recommends using 6000-watt halogen cycle lamps (Model Q6M53/CL/HT) on 1/2-inch centers. Since each lamp is 10 inches long, they propose packing the equivalent of 28.8 lamps per square foot of area. This translates into a lamp power density output of 173 KW/sq ft (165 Btu/sq ft-sec). Assuming efficiency ranges between 50 and 70 percent, only about 100 Btu/sq ft-sec is received by the specimen. Lamp voltage is 480 volts.

Solid-state (Silicon Controlled Rectifiers) power controllers are recommended. The Model 650, shown in Appendix C (Data Bulletin D650.1) is typical. Solid-state controllers have replaced thyratrons and ignitron-type mercury-arc rectifiers.

The Microstar microcomputer controller and programmer shown in Appendix C is an example of the kind of control equipment that is recommended. Thermocouples are recommended for temperature control transducers. The thermocouple is relatively cheap and accurate. Radiation pyrometers can be used, but require filters to eliminate reflection from the lamps. They also require correction for emissivity of specimen material (which may change

with time or temperature). One should select a pyrometer which is not responsive to radiation below 4 wavelength; tungsten is 2 . Probably the most severe disadvantage of pyrometers is their requirement for line of sight to the specimen. Crowding with lamps, connections and instrumentation make this very difficult.

Lamps should be located reasonably close to test specimens. A three-inch distance is typical.

Maximum efficiency (heat to specimen) with a tungsten quartz lamp configuration is about 72%. We consider 50% efficiency as a more practical limit.

Research Inc. reported having placed an array of T-3 lamps inside a larger quartz tube, with air forced through the larger tube for cooling. This arrangement was configured for a vacuum application. High heat flux levels, but very short lamp life (a few minutes) was reported.

4.1.4 Graphite Elements - Equipment User Survey Results

Survey information regarding high-temperature graphite element heater test experience and capability is summarized in Table 3.

Graphite elements have been used extensively for thermal structural tests of Space Shuttle thermal protection systems. A graphite radiant heating array for Shuttle wing leading edges is shown in Appendix C. Heat flux to 200 Btu/sq ft-sec is advertised by McDonnell Douglas.

The large scale testing experience reported in the survey was limited to test specimen temperature levels below 2650°F.

TABLE 3. GRAPHITE HEATER EXPERIENCE

	<u>User</u>	<u>Max. Temp.</u>	<u>Spec. Size</u>	<u>Environ.</u>	<u>Application</u>	<u>Comments</u>
1.	Rockwell (El Segundo)	2400 F	10ft x 10 ft	Vac	Space Shuttle Tiles	Operating exp. in vacuum simulating 60,000 ft elev.
2.	AEDC		Small	Vac		Operating exp. in vacuum
3.	Grumman	3500 F	2 ft x 3 ft	Air	Adv. Devel. Re-entry Vehicle Elevon Cont. Panel	Operating exp. in vacuum at 10 ⁻⁵ torr
4.	Sandia	5000 F	15 in dia x 2 ft cylinder			Can get heat flux 400-500 Btu/ft ² -sec
5.	Boeing	High	few ft ²			No large test vehicles heated with graphite See Appendix C
6.	McDonnell (St Louis)	2600 F	Vehicle "Leading Edges"	Air	Vehicle Structural Testing	
		4,000- 5,000 F	Small	Vac		
7.	LTV	2650 F	30 ft ²	Vac (10 ⁻⁵ torr)	Space Shuttle Nose Cone	75-80 elements (19 control zones)
8.	WPAFB	4150 F 1800F	6 in x 6 in 2 ft x 2 ft	Nitrogen		170 Btu/ft ² -sec
9.	McDonnell (Huntington Beach)					

Rockwell reports heating 100 sq ft to 2400°F (Shuttle tiles), LTV reports heating 30 sq ft of test surface to 2650°F (Shuttle nose cone) and McDonnell Douglas reports heating Shuttle wing leading edges to 2600°F.

Temperature levels up to 6000°F or higher and heat flux densities of 400 to 450 Btu/sq ft-sec were reported for small test specimen sizes (few square feet). Graphite heaters are used extensively for simulating nuclear heating effects.

Unlike tungsten quartz lamps there have been changes in graphite heater equipment and experience during the last twenty years.

More vacuum experience was reported with graphite heaters than with tungsten lamps. Rockwell International reported using graphite heaters back in the nineteen sixties when running launch profiles. Running launch profiles at about 60,000 ft they encountered arcing problems with lamps. Arcing problems were eliminated by using graphite heaters. They reported heating a 10 ft x 10 ft test specimen to 2400°F with the specimen mounted in an altitude chamber and programmed for launch profile and reentry (0-100,000 ft).

At high-temperature levels, oxidation in air can be a problem. McDonnell Douglas reports using graphite heaters (see Appendix C) for heating leading edges in air to 2600°F. Above 2600°F, a soft vacuum or inert gas atmosphere was used to prevent oxidation.

LTV reported having provided silicon carbide coated graphite elements for NASA to test a high-temperature wing section in an oxidizing atmosphere.

A special concern was indicated regarding the ability to operate in a hard vacuum because of outgas problems with graphite heaters.

No major problems with automatic control of graphite heaters was reported. Multi-zone control of 19 zones (75 to 80 heating elements) with each zone having programmed time/temperature profile for a given reentry profile was reported by LTV.

No major problems with safety were reported. Some failures of graphite elements to ground were reported. Test specimens can be damaged by arcing.

Some of the more important reasons given by users for choosing and preferring graphite heaters are summarized below.

- ° Graphite heaters operate with lower voltage than tungsten quartz lamps. They are, therefore, easier to handle from a safety standpoint.
- ° Graphite heaters are attractive because once designed they can be relatively cheap to make.
- ° Graphite heaters have the ability to provide high-heat flux rates.
- ° The use of graphite heaters eliminated arcing problems when operating at pressure altitudes up to 100,000 ft.
- ° Grumman reported 100-hour graphite rod life. This was actually better than that of tungsten quartz lamps.

Problems and limitations reported by equipment users included:

- ° Major limitation with graphite is the need for inert atmosphere or vacuum environment at high temperature to reduce oxidation. Life can be short in an atmospheric environment.
- ° There are no commercial equipment suppliers. (See section 4.1.5.)
- ° Carbon is fragile - must be careful of shock.
- ° Graphite can break and then short (arc) to ground.
- ° Graphite heaters tend to be porous, hence outgassing can be a problem in a hard vacuum. It is difficult to pump all the gas out at low vacuum levels.
- ° Graphite heaters are dirty.

4.1.5 Graphite Elements - Equipment Supplier Survey Results

No commercial suppliers of graphite heater systems for structural testing were identified in this study. Generally systems are custom built by users. However, McDonnell Douglas has built such systems for Government use.

4.1.6 Vortek Heater - Survey Results

An argon plasma arc lamp system is manufactured by Vortek Industries, Ltd. of Vancouver, Canada. The plasma arc lamp was developed to provide a higher power than was available from other continuous operating light sources.

The Vortek lamp system includes a lamphed and a service module. The lamphed includes water-cooled electrodes (copper base with tungsten tip) and connections for the various ancillary flow sources. A DC arc having a color temperature of approximately 6500°K is struck between the electrodes in argon gas at a pressure of 7 atm. The lamp envelope is a quartz tube, 21 mm in diameter, which is cooled by a spiralling stream of deionized water. The argon plasma arc is suspended in the center of the quartz tube, inside the spiralling cooling water flow. The arc is vortex-stabilized, i.e., the argon gas is given a high rotational velocity as it enters the lamp envelope. The arc diameter is 11 mm.

Three sizes of standard lamps are available:

Length	Input	Output
200 mm	100 KW	45 KW
150 mm	150 KW	60 KW
100 mm	300 KW	120 KW

Higher power systems are also produced by Vortek to meet special requirements.

The ancillary equipment contained in the service module includes a closed loop deionized water system for cooling the lamp envelope, a closed loop argon recirculation system, a power supply with AC to DC conversion, a high voltage ignitor, and a control system.

The major application of the Vortek lamp is in the semiconductor processing industry where it is used in optical annealing equipment. The high temperature of the arc and the high rate of heat

delivery allow annealing processes to be completed in a fraction of the time required using early equipment. This results in improved quality of the optically annealed components.

This system has a higher output power than any other available continuous power lamp. The AFWAL Structures Test Branch has purchased the most powerful system made by Vortek and is testing its performance for heating structural material surfaces. A single lamp with a 6-inch x 4.5-inch reflector was purchased initially; this was found to deliver 1 KW/sq cm (880 Btu/sq ft-sec) to a 24-square-inch surface located 3 mm from the lamp. A second lamp assembly, having two lamps and a single two-cusp reflector, is being purchased by AFWAL for further evaluation.

While this system is capable of producing very high heating rates, at present the cost of the system is quite high. For a given heated surface area requirement, the Vortek system would cost on the order of 10 times as much as a system using T-3 lamps.

4.1.7 Miscellaneous Heaters - Survey Results

In addition to the three principal heater types described above, a few miscellaneous techniques were reported being used for thermostructural testing.

Vought Aerospace and Defense Corporation reported having used helical shaped silicon carbide Glowbars fabricated by Carborundum. The maximum allowable element temperature was reported to be about 3200°F. Maximum attainable test specimen temperature is correspondingly much lower.

Boeing Aerospace reported using a four module arc imaging device capable of delivering up to 700-1000 Btu/sq ft-sec. Arc imaging heaters are used for material tests and other applications where test specimen area requirements are small. Grumman Aircraft Systems Division also reported experience with carbon arc lamps.

Boeing Aerospace also reported using a 10,000°R plasma heater. Lamps are Xenon short arc plasma type purchased from Duratest. High cost was reported to be the major problem.

4.2 Structural Loading Techniques and Equipment

The combination of intense aerodynamic heating (skin temperatures approaching 3000°F or more on leading edges), large cryogenic fuel tanks with temperatures down to -423°F, and the need for compact lightweight airframes with thermal protection systems means high-temperature gradients which can cause significant thermal stresses. Unlike lower Mach number vehicles, thermal stresses may no longer be small compared to applied loads.

While aerodynamic loading will tend to be more or less in phase with heating, inertial loading may not be. Inertial loading is dependent on vehicle weight and type of maneuvers to be encountered. For the selected Reference Vehicle (see Figure 1), over 90% of the gross total weight is liquid hydrogen and oxygen. Maximum inertial loads for this vehicle will tend to occur early in the flight during the ascent portion of the mission when the fuel tanks are full. Peak aerodynamic heating on the other hand will occur more or less midway through the reentry portion of the flight. Peak loading and heating will thus occur at different times in the mission.

Simulation of combined stresses from thermal and applied loads requires that transient heating be accompanied by transient load-

ing. Thermostructural testing must be conducted under true-time conditions. In accordance, both heating and loading must be programmed.

The structural loading system must be able to apply loads of prescribed values at prescribed times to a test structure. It must be capable of simulating in-flight loading of an aircraft throughout its mission profile. The duration of a typical mission, including ascent and descent, will be of the order of an hour or more. For evaluating vehicle service life based on total allowable mission cycles (fatigue type testing) it will be difficult to compress the time history by shortening the cycle time to reduce test time. Unfortunately, thermal effects are much more sensitive to time than applied loading effects.

An important objective of this project was to identify the state-of-the-art techniques and equipment for satisfying these load simulation requirements.

4.2.1 Structural Loading System Requirements

The following basic loading requirements are required for high-temperature thermostructural testing.

- ° Suitability for loading large test vehicle surface areas (up to 10,000 sq ft) having temperature levels as high as 3000°F. System must be able to interface with radiant heating equipment.
- ° Capability for automatic programmable closed-loop load control. Automatic multiple zone load control is required; likely vehicles may require up to 200 independent control channels.

- The system must be suitably small. The space available within the vacuum test chamber will be small and crowded with loading connections and instrumentation. The system must have the capability of operating at high vacuum (if altitude simulation is necessary).
- Reasonable cost. Although the cost for a single channel may not be large, a great many modules may ultimately be required.
- Ability to duplicate aerodynamic and inertial load profiles as a function of time throughout a flight mission.
- Need to be able to load to 2.5 G's. If the vehicle weight is 1.2×10^6 lbs, then 3×10^6 lbs loading is required.

4.2.2 Loading System Components - Survey Results

The high-temperature structural test facility users questionnaire requested information regarding structural loading state-of-the-art techniques and equipment used. The information solicited included types of application and types of equipment as well as the highest temperature test specimen loaded. This served as a screening survey, identifying sources with potentially useful information. Additional information was then obtained through follow-up questionnaire or follow-up telephone contacts.

Survey results suggest that most structural loading systems have been developed or built by the individual user facilities using commercially available components (i.e., actuators, controllers, load cells, etc). There are, however, suppliers of complete systems.

Total systems are commercially available from suppliers such as MTS and FluidDyne. They offer turnkey automatic programmable closed-loop multiple zone loading systems. Even with turnkey systems it is customary for the customer to provide all load fixturing. Commercial systems typically terminate with rod or clevis ends on actuators. Current state-of-the-art equipment is essentially designed for low temperature operation at atmospheric pressure levels.

The survey included a visit to MTS Systems Corporation. They have provided automated static and fatigue loading equipment to several government airframe test facilities.

There is in-house experience at FluidDyne with turnkey loading systems. FluidDyne recently supplied an airframe fatigue test facility capable of applying a wide range of loads simulating in-flight loading of an aircraft throughout its service life to the AERO Industry Development Center, Republic of China (Taiwan).

Cyber Systems is an example of a supplier of load control systems for full-scale aircraft fatigue testing.

Most of the major airframe test facilities report using multi-channel electronically controlled, hydraulic actuated structural loading systems with capability to apply repetitive loads of prescribed values. The system is typically comprised of three basic subsystems: the Hydraulic System, the Load Control System, and Loading and Reaction Fixtures.

Hydraulic System

A typical hydraulic system consists of all the hydraulic components required to convert the signals generated by the Load

Control System into loads on the test structure, and provide the necessary load feedback and safety monitoring information to the Load Control System. The major elements are load cylinders, servo valves, manifolds, load cells, hydraulic power supply, cooling water system, and interconnecting piping. As many as 200 load control channels (one serving each 50 sq ft of test vehicle surface), might be required for a full-scale test vehicle such as the Reference Vehicle.

In a typical system, several electric motor driven variable displacement pumps maintain the desired flow and hydraulic pressure. A system satisfying the high-temperature test facility requirements for testing the full-scale Reference Vehicle would have a hydraulic system capable of providing up to 2000 gpm at 5000 psi to 200 servo valves.

The hydraulic power supply will require a cooling system to dissipate the power transferred to the oil in the form of heat. A water system with cooling towers is typical.

Servo valves regulate the direction and flow rate of hydraulic fluid to the cylinders. Individual cylinders simulate different loading conditions.

Load cells are an integral part of typical servo loops, providing force feedback for load control and error monitoring. Each cylinder will have a load cell attached to the cylinder rod and the test article.

Distribution manifolds normally transfer oil from the power room to and from the test chamber. Each manifold subsequently distributes oil to and from several servo valves.

Load Control System

State-of-the-art Load Control Systems are built around multi-channel central processors with wide range test features and auxiliary data acquisition capabilities. These systems provide computer controlled closed loop operation of individual servo-controlled hydraulic cylinders and special purpose functions for the application of structural loads to test articles. They perform all of the control and data acquisition tasks, including monitoring of the loading process to assure that load spectrums are faithfully implemented and to protect test articles from damage caused by incorrect load applications.

Load control software performs the function generator and servo controller functions. Systems are capable of running large spectrum tests in accordance with load spectrum tapes or are able to operate independently using manually input load spectrum data.

The load control systems provide monitoring and are able to control special actions of various abnormal or normal conditions.

Load and Reaction Fixtures

Application of the required loads for static and fatigue tests is accomplished by means of electronically controlled hydraulic actuators. For low-temperature applications, the desired loads are typically applied to the vehicles or components by means of load rods and whiffletrees, which are in turn attached to loading pads bonded to the aircraft surface.

In performing structural tests at temperatures of 1000-3000°F, the method of applying the desired loads to the vehicles and components is the major consideration. Attachment methods which

preserve the appropriate stresses in the test structure while having the capability to withstand the elevated surface temperature are critical. In addition, thermal insulation of the hydraulic cylinders from the loading rods and radiation shielding of the hydraulic actuators, reaction structure, and load control equipment surrounding the test article also become more critical at these higher temperatures than at the more typical 500-600°F temperature levels needed to simulate aerodynamic heating at speeds on the order of Mach 3.

If the loading and load control equipment can be adequately protected from the thermal environment, no special requirements will be placed on the load system components other than being able to operate in a vacuum and with load attachments at 1000-3000°F, as opposed to more conventional temperatures. Thermal protection is much easier when radiant heat sources are used to heat the test article surface, as opposed to convective or inductive heating and, therefore, restriction of the heating methods to radiant heating is entirely appropriate.

Since the electric power requirements for the radiant heat sources will be large when testing at very high temperatures, such testing could pose some problems regarding the need for power conditioning and electrical isolation of the load control and data acquisition equipment.

In view of the above discussion, the key elements of the survey and evaluation efforts regarding fatigue and static test facilities, techniques, and equipment were methods for attachment of the whiffletree type loading systems to the test articles, methods for thermal protection of structural test system components, and electrical isolation capabilities of electronic components.

Survey results suggest that silicone rubber bonded tension plates, developed over twenty years ago for testing Mach 2 or 3 vehicles (see Reference 7) represent the state-of-the-art technology for low temperature structural testing. Plates are typically of the order of 2 x 2 inches with spacing of the load application points depending on test specimen stiffness and load distribution. A minimum spacing of 6 inches is commonly used. These plates permit excellent temperature simulation while loading because the plate and bonding agent allows rapid heat conduction.

Unfortunately, silicone rubber bonded tension patches have a maximum allowable temperature limit of 600°F for steady-state static testing and 400-500°F for fatigue testing. Higher temperatures can be accommodated for short time transient testing.

The survey revealed no advances in high-temperature tension patch technology. For temperatures above 600°F, experience is limited to loading applied through direct mechanical attachments as described below.

One of the first high-temperature test simulations (using tungsten filament quartz lamps) with rapid loading was done on the Hawk Missile at AFWAL. As reported in Reference 7, load application was accomplished with flexible steel cables and quartz conical compression washers. Holes were drilled through the test structure and the cable-quartz washer combination threaded through and loaded in tension. Research on this quartz compression loading washer indicated that thermal shielding would be minimal and would not affect the temperature distributions.

This method is not practical for general test work because drilling through the structure alters its strength characteristics and the washers are prone to chip and break.

With some high-temperature test articles it is possible to apply loading to a cool backside of the test specimen. McDonnell Douglas, St. Louis, reported structural testing with specimen temperatures as high as 3700°F, but with structural loading applied to the cool backside (300-400°F).

Boeing reported using pin joints, welds, bolts, and other mechanical load attachment methods for temperature levels above 600°F. They suggested using quartz tie rods for compressive loads, since quartz has high compressive strength and low conductivity. For tensile loads, materials like Rene 41 might be considered. A good deal of Rene 41 was used in the Dyna Soar project. Boeing reported a maximum load specimen temperature of 2500°F.

NASA Ames Dryden Flight Research Facility reported high-temperature structural loading test experience with the X-15 wing tests (test specimen temperatures to 1200°F). They reported using high-temperature cables, which ran through the radiant heater reflectors to 1-inch wide by 0.050-inch thick corrugated strips which were riveted to the upper surface of the wing structure. The lower part of the corrugation was riveted to the wing and the upper corrugation was attached to cables. Hydraulic jacks were located outside the radiant heating system in a cool environment to avoid overheating the load cells and actuators.

NASA Ames Dryden also reported test specimen temperatures to 1900°F with current Hypersonic Wing Tests. The test article was specially designed as a test structure, with hard points for

attachment of mechanical rods built into the structure. Mechanical rods with bayonet-type fittings for attachment apply both compressive and tensile stresses. The rods pass through the radiant heating system to hydraulic jacks located in a cooler environment. The rods which apply horizontal loads are subject to heat conduction into the load cells, so water cooled fittings are installed in series with the loading rods to prevent the load cells from becoming hot. The load cells are also shielded from radiation with insulation. The wing structure is cantilevered with the root attachments being water cooled fittings to prevent the support structure from becoming too hot.

High-temperature techniques mentioned by other users included quartz rods, pull rods (turbine alloy materials) and carbon straps. Ceramic insulators have been used between actuators and load rods.

In addition to locating hydraulic cylinders outside the reflector area, water cooling of the actuators has also been done. Rockwell International (Downey, CA) reportedly shrouded the actuators and passed nitrogen through them for cooling.

High-temperature test specimen materials have included Rene' 41, Inconel, metal matrix composites, etc.

The major problem with direct mechanical attachments (i.e., load points, holes, welding, etc.) is that they can alter structure strength characteristics and thus compromise true simulation of the test vehicle.

Installation and operation of loading equipment within the confines of a vacuum chamber introduces special problems. One problem will be packaging the actuators and fixtures within the

small and crowded test chamber. Hydraulic and cooling systems must be capable of operating in a vacuum. Special designs may be required.

4.3 Instrumentation

All three types of instrumentation used in elevated temperature structural testing, i.e., temperature, strain and deflection, have the same basic criteria.

- ° Suitability for measurements at high temperature from 1000 °F to 3000 °F.
- ° Capability of being and remaining attached to likely aerospace vehicle materials.
- ° Durability at the maximum temperature at which measurement is intended.
- ° Suitably small - the environment in the region close to the test vehicle will be crowded with loading connections to the vehicle, with radiant heating equipment and with other instrumentation.
- ° Reasonable ruggedness.
- ° Either no requirement for calibration after installation or ease in calibration if required.
- ° Capability of operating at high vacuum.
- ° Reasonable cost - although the cost of a single instrument together with its processing equipment may not be large, a great many instruments of all types will be required.

In general, the necessary instrumentation must be attached to that surface of the vehicle whose characteristic is to be measured. In assessing the suitability of the instrumentation for measurement, some assessment must be made of the likely material. At this time it cannot be known with any degree of certainty what that material may be. For the outer surface of the vehicle, the assumption has been made for this study that the highest temperature regions of the vehicle, i.e., the stagnation region of the body and the stagnation lines of the lifting and stabilizing surfaces will be similar to corresponding regions of the Space Shuttle, i.e., carbon-carbon composites with a silicon carbide outer coating.

For lower temperature regions of the outer surface, the analysis of Reference 3 indicates that the outer material may be a super-alloy honeycomb such as Inconel 718 and/or Rene 41. The outer material will be attached to spars or frames. These in turn will be attached to truss members which provide internal support.

4.3.1 Temperature Instrumentation

4.3.1.1 Design Criteria

In structural testing, temperature instrumentation will be required to provide control of the radiant heating environment as well as to provide diagnostic information for strain and deflection measurements. The control function, which is probably the more important of the two, requires reliable information throughout the entire temperature-loading cycle. For safety reasons, redundancy is required, particularly in the high heating regions.

4.3.1.2 Temperature Instrumentation - Survey Results

The structural test facility and equipment user questionnaire sent to industry and government facilities requested information regarding temperature measurement state-of-the-art techniques and equipment used.

Questionnaires on measurement of high temperatures were also prepared and submitted to manufacturers. At the same time, a brief literature survey of such instrumentation was conducted in order to aid in interpreting questionnaire responses as well as to supplement the instruments which were identified in the responses. Results of the literature survey are shown in Table 4.

The table indicates that the instrumentation likely to be of use can be divided into two kinds, contact and non-contact types. The contact types consist entirely of various kinds of thermocouples. Other instrument types exist and may be of use by the time the facility is to be designed, but at present they are in the development phase. The platinum resistance thermometer has temperature capabilities in the region of interest but it may not be suitable in general since resistance changes not only with temperature but also with change in geometry. To be of use, the resistance thermometer would have to be used on unstrained surfaces.

For relatively high-temperature regions, the thermocouples may be welded to the surface whether that surface be external or internal. Where the surface is not a metal, e.g., the fuselage nose cap and the stagnation regions of aerodynamic surfaces, welding is not suitable.

TABLE 4. ELEVATED SURFACE TEMPERATURE INSTRUMENTATION - LITERATURE SURVEY

<u>Instrument</u>	<u>Temp. Range °F</u>	<u>Status</u>	<u>Remarks</u>
<u>Thermocouples</u>			
K(Chromel-Alumel)	Amb. to 2000	Operational	
R(Pt: Pt - 13% Rhodium)	Amb. to 2700		
S(Pt: Pt 10% Rhodium)	Amb. to 2700		
B(Pt - 6% RH: Pt - 30% RH)	<1000 to 3100		Become brittle with age
WRe(W - 5% Re: W - 20% Re)	32 to 4200		Longer life and far less emf drift than K T/C's
Microsil-Nisil			
(Ni-Cr-Si/Ni-Si-Mg)	>1800		
J(Iron-Constantan)	to 1400		
E(Chromel-Constantan)	to 1600		
(Pt 40 Rh-Pt 20 Rh)	to 3092		
<u>Resistance Temperature Detectors</u>			
Platinum	-300 to 1400	Operational	Good linearity; good long term stability
Tungsten	-100 to 5000		
<u>Pyrometers</u>			
<u>Radiation</u>			
Broad Band	0 to 7000		
Single Band Pass	0 to 7000		
Ratio (Two Color)	0 to 7000	Operational	Require line-of-sight
Optical	1400 to 6300		Compares color of incandescent body with that of controlled wire filament
Infrared	0 to 6000		Compares radiation emitted with that emitted by a controlled source
<u>Infrared Thermometers</u>	-30° to 2000°	Experimental	Require Line-of-Sight; need temperature protection; can be up to 1000 ft from target; very small target
<u>Optical Fiber Thermometer</u>	(500 to 2000 C)	Operational	Radiant energy from a sensor is optically coupled to photosensors for conversion to an electrical signal.

Alternative methods of attachment/fabrication of relatively high temperature thermocouples are being developed for the temperature measurement of stator vanes and turbine blades of jet engines. The objective of much of this work is a reliable, high-temperature, fast-response thermocouple which interferes as little as possible with the flow field. The best result thus far is a thin-film instrument deposited in successive layers on the vane or blade. Careful surface cleaning and deposition of a suitable substrate are necessary. (See, e.g., Reference 5).

A thermocouple attached to a gas turbine experiences a somewhat different environment than one attached to a surface which undergoes varying temperature and stresses typical of an aerospace vehicle. In the latter case, durability, reasonable accuracy at high temperature and relatively small size are all important; fast response is perhaps less necessary.

A relatively thick-film thermocouple can be built up in the same manner as a thin-film instrument thus providing additional durability. The thick film provides additional margin against oxidation or evaporation of the thermocouple material at high temperature.

It will probably be necessary to provide temperature measurements on the highest temperature regions of the vehicle even though strain measurements may not be required. To provide the proper temperature distributions in the regions where strain measurements are required, the correct temperature must be maintained in the stagnation regions and therefore measurements must be made. Thermocouples have been successfully attached to carbon-carbon composites and heated to at least 2500°F (see Ref. 6). As in all attachments to high temperature surfaces, careful cleaning of the surface followed by multicoating and, at least in

this case, curing with a suitable adhesive is necessary. There is some uncertainty concerning possible chemical reaction between the thermocouple material and carbon at high temperatures (Reference 6).

Results of the equipment user and manufacturers survey are shown in Table 5. Information from those respondents whose experience lies outside the temperature range of interest have not been included. Where results from the screening questionnaire indicated that the respondents had particularly useful information, follow-up telephone calls were made or in some cases, follow-up questionnaires were sent. As expected, thermocouples and pyrometry are the principal means of measuring elevated temperatures by those organizations responding. Since, in general, instrumentation requiring line-of-sight may not be feasible, thermocouples remain the single device proven capable of measuring temperature through the desired temperature range. Although care must be taken in selecting the appropriate thermocouple metals, in attachment to the surface and in selection of leads, existing thermocouple thermometry will be satisfactory for high temperature structural testing.

4.3.2 Strain Instrumentation

4.3.2.1 Design Criteria

In addition to the criteria for all the instrumentation as indicated in Section 4.3, the following are specific to the strain instrumentation.

- ° maximum strain approximately 5000 microstrains (0.5%)
- ° relatively small variation of gage factor with temperature

TABLE 5. ELEVATED SURFACE TEMPERATURE INSTRUMENTATION
 EQUIPMENT USER AND SUPPLIER SURVEY

User/Developer	Instrument Type	Maximum Surface Temp. °F	Remarks
Boeing Aerospace/Tulalip/ Kent	Tungsten-Rhenium T/C IR (Barnes Engrg.)	4500 6000	
Grunman	Pyrometers	3500	
Lockheed Corp. (Burbank, Rye Canyon, Palmdale)	Thermo-Electric	2000	
LTV	Optical Pyrometer Chr-Al T/C	3700 2450	Space Shuttle Nose Cap Attached with ceramic cement
Martin Marietta - Denver, CO	E (Chr/Const) T/C	1000	
McDonnell Douglas - Huntington Beach	K (NiCr/NiAl) and E (Chr/Const) T/C	2000	
McDonnell Douglas St. Louis, MO	T/C (Noble Metal) Pyrometers	3200 5000	
Rockwell Int'l/Downey	Various	2000	
Rockwell Int'l El Segundo	Heat Flux Sensors + Embedded T/C's	2400	

TABLE 5. ELEVATED SURFACE TEMPERATURE INSTRUMENTATION
 Continued

User/Developer	Instrument Type	Maximum Surface Temp. °F	Remarks
Sandia National Labs	T/C	3000	Ultrasonic thermometry developed at Sandia - used when temps are beyond capability of refractory metal T/C. Difficult measurement.
	Optical Pyrometer	>3000	
	Ultrasonic Thermometry	>3000	
AEDC		1200	Elevated temp. struc. testing
AF Rocket Propulsion Lab	Tungsten - Rhenium T/C	4200	
	Optical Pyrometer	3600	
Wright Patterson AFB	Tungsten - Rhenium T/C	4200	
NASA/Dryden	T/C	2600	
NASA Langley	J (Fe/Const)	1800	
NASA Lewis/Cleveland		2000	

- ° slight zero shift with temperature

4.3.2.2 Strain Instrumentation - Survey Results

As was the case for temperature sensors and for the same reasons, a brief literature survey of suitable strain instrumentation was conducted. At the same time, users and manufacturers were surveyed. Results of the literature survey are shown in Table 6.

Table 6 is not intended to be a comprehensive survey of existing strain instrumentation. The literature survey upon which the table is based was conducted in order to uncover the most common types of such instrumentation together with their uses and limitations.

Strain instrumentation, like temperature instrumentation, falls into two main categories, contact and non-contact. Contact types are either welded or cemented to the specimen surface and as a result, suffer from difficulties in attachment and differential expansion problems between the gage and the specimen surface. Other problems which can occur in a contact strain sensor are:

- ° Variation in gage factor due to variation in resistivity of the gage material with temperature.
- ° Variation in resistance of the gage with temperature due to variation in non-electrical internal properties of the various materials comprising the gage.

TABLE 6. RESULTS OF A BRIEF LITERATURE SURVEY OF ELEVATED TEMPERATURE STRAIN INSTRUMENTATION

Type	Principle	T _{max} of	Status	Remarks
<u>Resistance</u>	Resistance varies with strain			
Wire Gages		1300*	Operational	
Thin Film		1200	Operational (Probably)	Fragile
Weldable (Ailtech)		1100	Operational	
<u>Capacitive</u>	Capacitance varies with strain			
Differential (Boeing/Hitec)		1500	Operational	Manufactured by Hitec
Cerl-Planar		1200	Operational	Drift Rates approximately 0.2 microstrains/hr.
Thin Film		1500	Experimental	United Technologies - untested as of mid '85
<u>Acoustic</u>				
Acoustic Guided Wave Sensor	Wave velocity varies with strain		Very Experimental	
<u>Optical</u>				
Double Core Fiber Optic	Crosstalk between 2 optical fibers is dependent on strain and is independent of temperature	1200	Experimental	Connect to metal surface, requires laser, needs optical access
Speckle Photogrammetry	Illuminate specimen by laser, giving speckle pattern; photograph. Use interferometer as comparator to measure displacements between strained and unstrained specimen photographs.			

* pt. - 8% W said to have been used successfully to 1800°F

- ° Variation in zero strain of the gage or drift resulting from metallurgical changes associated with continued exposure to temperature.
- ° Failure of thin lead wire/gage junction due to handling.
- ° The gage must be electrically isolated from the specimen surface. Depending upon the type of gage, this may or may not be a problem.
- ° A problem mentioned above, i.e., differences in coefficients of thermal expansion between gage and specimen can usually be reduced by calibration. However, there can still be a problem where the resultant apparent strain is large compared to the loading strain.

Non-contact types are radiative in nature and must be able to "see" the specimen surface. This presents a real difficulty when considering the use of such instruments for elevated-temperature structural test application. Here the region in the vicinity of the specimen is crowded with radiant heat lamps and reflectors as well as loading and deflection sensor attachments.

Results from questionnaire response are presented in Table 7. Information from those respondents whose experience lies outside the temperature range of interest have not been included. Where results from the screening questionnaire indicated that the respondents had particularly useful information, follow-up telephone calls were made or in some cases, follow-up questionnaires were sent. It may be seen that apart from some optical techniques which suffer from the same line-of-sight requirement as optical temperature instrumentation, only two instruments suitable for temperatures above 1000°F are commonly used. These

TABLE 7. ELEVATED-TEMPERATURE STATIC STRAIN INSTRUMENTATION
 QUESTIONNAIRE RESPONSES

User/Developer	Instrument Type	Maximum Surface Temp. °F	Remarks
Babcock & Wilcox	Ailtech	1000	Attach - Weld
	Hitec	950	Attach - Weld
	Cerl Planar	950	Attach - Weld
	B&W	1500	Attach - Weld
	B&W Fiber Optic	1000	Attach - Weld
	Free Filament	>1000	Attach - Ceramic Adhesives - Adhesives are Hygroscopic - Large apparent strain can cause ceramic cracking
Battelle Columbus	Free Filament	2000	Rod-Flame Spray (Rokide) Problems: G.F. differs between tension and compression - Large apparent strain - Zero Shift - Drift
Boeing Aerospace/Tulalip/ Kent	Hitec/Boeing Capacitive Ailtech Weldable		
General Dynamics - Ft. Worth	Micro Measurements	600	
Grumman	Ailtech Extensometers	1200	
Lockheed Corp. (Burbank, Rye Canyon, Palmdale)	BLH/Measurement Group	800	
LTV	Optical (High Temp.) Strain Gages (to 1000°F)		

TABLE 7. ELEVATED-TEMPERATURE STATIC STRAIN INSTRUMENTATION
QUESTIONNAIRE RESPONSES - Continued

User/Developer	Instrument Type	Maximum Surface Temp. °F	Remarks
Martin Marietta (Denver, CO)	LVDT	Low	
McDonnell Douglas (Huntington Beach)	Hitec Capacitance	1500	
McDonnell Douglas (St. Louis, MO)	Hitec Capacitance	1500	(1) The coax lead systems are bulky and difficult to install. (2) The gages are intended for axial strain measurements - bending strains require standoff correction. (3) Radiant heat lamps cause excessive electrical noise in the system. (4) The gages are prone to zero shift errors in vibratory environments due to internal leadwire construction.
Rockwell Int'l (Downey)	Various	1200	
Sandia Nat'l Labs	Hitec Capacitance	1500	
United Technologies Research Center	Fiber Optic Holographic	1500 >3000	
AEDC	Laser Interferometry	1200	Elevated Temp. Structural Testing

TABLE 7. ELEVATED-TEMPERATURE STATIC STRAIN INSTRUMENTATION
QUESTIONNAIRE RESPONSES - Continued

User/Developer	Instrument Type	Maximum Surface Temp. °F	Remarks
Wright Patterson AFB	Hitec, BLH Hitec Capacitance	1500 1500	Flame (Rokide) Spray
NASA/Dryden	Ailtech Weldable Hitec Capacitance	1200 1500	Spot Weld Attach't Spot Weld Attach't - Shift, Durability, Noise, Temp. Sensitivity and Apparent Strain Problems
NASA Langley	Strain Gage (Micromeasurements)	700	
NASA Lewis/Cleveland	Probably Extensometer	2000	

are: the Boeing/Hitec capacitance gage, useful to 1500°F; and the Ailtech weldable gage whose upper limit is 1200°F. It is believed that the CERL-Planar gage is also used effectively up to approximately 1200°F.

Even the above gages must be used with great care in order to achieve useful results. For example, the Boeing/Hitec gage, useful to 1500°F has been reported as subject to a number of problems as follows.

- ° Apparent Strain - as discussed earlier this is the result primarily of a mismatch between the thermal coefficient of expansion of the gage and of the specimen surface to which the gage is attached. Theoretically this can be eliminated by careful temperature calibration.
- ° Durability - The lead wires from connectors to gage are very fine and extremely delicate. They can either separate from the gage or actually break unless they are very carefully attached and handled.
- ° Noise - When used in a radiant lamp environment, a great deal of scatter is experienced, which is not present in the absence of such heating.
- ° Temperature Sensitivity - If the gages are exposed, and where quartz lamps are used, they pick up every flash of the lamp. A metal shield can prevent this but great care must be taken to avoid a "cold" spot on the specimen.
- ° Shift - Inconsistency has been reported in the zero reading from day-to-day, complicating the measurement process.

In addition, the gages are designed for axial strain measurements. Since the gage element is elevated above the specimen surface, bending strains require a standoff correction.

Battelle Columbus reports the successful use of a free filament gage, i.e., without a foil backing, to 2000°F. However, the gage exhibits the following problems:

- ° The gage factor depends upon whether the specimen is in tension or compression. The effect apparently occurs at the loops in the gage.
- ° The apparent strain is very large. It is due to differences in coefficients of thermal expansion and to differences in resistivity, when the latter is considered to be a part of apparent strain. It can be very much reduced by calibration.
- ° Zero shift, probably due to plastic deformation of the substrate, but it may also be due to slippage of the wire in the encapsulation (ceramic). There is a hysteresis which is essentially constant and can be accounted for by simply knowing whether or not the system is heating or cooling.
- ° Drift, probably a metallurgical effect. It has been noted that when kept at temperature for 15 minutes to an hour, the drift stabilizes. This is probably due to the aluminum in the gage oxidizing and protecting the gage from further metallurgical change.

Based upon the literature survey and the questionnaire responses, at the present time there are no reliable and proven strain gages useful beyond 1500°F, although free-filament gages may be useable to 2000°F.

4.3.3 Deflection Instrumentation

4.3.3.1 Design Criteria

The same general requirements as necessary for temperature and strain instrumentation which were described in Section 4.3.1.1 are also applicable to deflection instrumentation. In addition, deflection sensors must be capable of measuring deflections of three feet or more estimated deflection rates of as much as 250 inches/second.

4.3.3.2 Deflection Instrumentation Survey

The structural test facility and equipment user questionnaire included requests for information concerning deflection instrumentation. Results are given in Table 8. Information from those respondents whose experience lies outside the temperature range of interest have not been included. Where results from the screening questionnaire indicated that the respondents had particularly useful information, follow-up telephone calls were made or in some cases, follow-up questionnaires were sent. Questionnaires were also sent to suppliers of such instrumentation. Results of these surveys are given in Table 9.

The results indicate that no deflection sensor is capable of operating in the high-temperature environment required. Therefore cooled shields are necessary for the instrument with an attachment from the instrument to the specimen which may or may

TABLE 8. ELEVATED-TEMPERATURE DEFLECTION INSTRUMENTATION - EQUIPMENT USER SURVEY

User	Instrument Type	Maximum Surface Temp. °F	Connection	Remarks
Boeing Aerospace, Tulalip/ Kent	Laser Interferometer Potentiometer		Quartz Rod	
General Dynamics - Ft. Worth	Lockheed	260	Wire	
Grumman Aerospace	Potentiometer	350		
Lockheed Corp. (Burbank, Rye Canyon, Palmdale)	Collins	600		
LTV	Optical Extensometer	3700		
Martin Marietta - Denver, CO	Laser Interferometer			
McDonnell Douglas - Huntington Beach	McDonnell	350		
McDonnell Douglas St. Louis, MO	Interferometer (Autocollimation Type)			Small Deflections
Rockwell Int'l Downey	Various	600		

TABLE 8. ELEVATED-TEMPERATURE DEFLECTION INSTRUMENTATION (Continued)

User	Instrument Type	Maximum Surface Temp. °F	Connection	Remarks
Arnold Engineering Development Center		1200		Elevated Temp. Struct. Testing
Wright Patterson AFB	LVDT Potentiometer	200 Amb		Range - 10 inches Range = 12 ft
NASA/Dryden	Potentiometer (approximately 150°F Limitation)	1900	Stainless Steel Cable, Quartz Rod	
NASA Lewis/Cleveland	Probably Extensometer	2000		

TABLE 9. ELEVATED-TEMPERATURE DEFLECTION INSTRUMENTATION - SUPPLIERS SURVEY

Supplier	Instrument Type	Max. Temp. °F	Operation in High Vacuum	Range	Remarks
Celeco Transducer Products	Potentiometer	250	Uncertain	To 1000"	Cost approx. \$300
Hitec Corporation	Capacitive Reactance	1600		0.070"	
Hottinger Baldwin Measurements, Inc.	Inductive Displacement	660	to 10 ⁻⁹ Torr	to 15"	Cost \$600 to \$1800
Schaevitz Engineering	Linear Variable Differential Transformer (LVDT)	1200	to 10 ⁻⁶ Torr	to 4"	Cost \$3000 to \$5000

not have to be cooled as well. Depending upon the circumstances, cables or low coefficient of thermal expansion rods such as quartz or Invar have been used successfully as connectors from the instrument to the specimen. Corrections for change in length of the connector due to heating may or may not be required depending upon the accuracy desired.

As indicated above, Table 9 presents the results of questionnaires sent to deflection instrument suppliers. Since there are a large number of suppliers of potentially suitable contact type instruments, no attempt was made to include them all or even a significant number of them. Instead, questionnaires were sent to a relatively few firms whose instruments differed substantially from one another in order to be able to assess them as a class.

We were not at all certain that a deflection sensor can operate successfully in a high vacuum. Accordingly, this was one of the questions asked of suppliers of such instruments.

Results of Table 9 indicate a considerable difference in the responses. Nearly all of the types shown may be suitable for some combinations of range, vacuum capability, cost and temperature shielding requirements.

5.0 ADVANCED HIGH-TEMPERATURE TEST FACILITY BUDGET COST ESTIMATE

For cost evaluation and Air Force planning purposes, a budget cost estimate was developed for a high-temperature test facility capable of testing full-scale airframe structures such as the selected Reference Vehicle. Test facility requirements are described in Section 3.2. The test chamber and major support systems are shown conceptually in Figure 3. The test chamber is a horizontal vessel 100 ft in diameter and 150 ft long.

A cost estimate was also developed for a smaller airframe component test facility. The test chamber in this facility is 30 ft in diameter and 60 ft in length.

Major facility components and the sources and assumptions used in estimating their costs are described below.

Vacuum Test Chamber

One of the important environmental parameters to be simulated in the test chamber is vacuum. Many thermal protection systems require vacuum for proper simulation of thermal conductivity. Effects of ultrahigh-altitude simulation (Reference 8) which can affect the test include corona discharge or arc-over of electrical equipment and material property changes resulting from outgassing. Manual controlled fixed pressure level operation to 10^{-6} torr will satisfy test facility requirements. We assume that automatic programmed altitude simulation is not necessary. The cost of adding the ability to change pressure levels rapidly would be very high. Large cryogenic pumping capability would be needed.

For personnel safety and test specimen protection in the event of a hydrogen leak, the test specimen must be surrounded by an inert atmosphere (typically nitrogen or high vacuum) during operation. Where an inert gas is to be used, a vacuum test chamber is required to remove oxygen prior to filling with nitrogen or other inert gas. The test chamber must be designed for a positive relief pressure of 25 psig to permit rapid removal of hydrogen and to allow for pressure control and removal to burn (flare) stack.

A budget estimate of \$61.5 million (installed) for the large 100-by 150-ft test chamber and support equipment (including vacuum pumps, etc.) was obtained from CBI Na-Con Inc. The costs are based on a system meeting the following design requirements.

- ° Chamber Shape..... Horizontal Domed End Chamber
- ° Chamber Diameter..... 100 ft.
- ° Chamber Length..... 150 ft.
- ° Material Steel with SS clad liner
- ° Vacuum Pressure..... 1×10^{-6} torr
- ° Maximum Positive Pressure..... 25 psig
- ° Pump Down Time from
Ambient Pressure..... 24 hours
- ° Reinforcing rings with internal load fittings to accommodate test vehicle loads.

- End domes with reaction fittings designed to carry inward-outward forces to accommodate test vehicle loads.
- One end of dome designed to be hinged to the chamber and to be opened for test specimen access.
- Flanged openings provided for: Emergency flare stack vents, electrical, instrumentation and other line penetrations; viewports; test vehicle pressure relief system; lines for liquid and gaseous hydrogen; liquid and gaseous nitrogen; gaseous helium; drain; and monitoring and control devices.
- Roughing pump system (Roots blowers and boosters).
- Cryopumps used for 1×10^{-6} torr (2 of 8 cryopumps included are for test specimen outgassing).
- Liquid nitrogen pumps and vaporizer for approximately one hour gaseous nitrogen repressurization to atmospheric.
- Internal water baffles provided to protect cryopumps.
- Controls, motor control center, liquid nitrogen piping for cryopumps.
- Air purge system.
- SS liner to minimize outgassing rates.

A budget cost estimate of \$8.5 million (installed) was obtained from CBI Na-Con for the smaller 30-ft diameter by 60-ft long

vacuum chamber and support system. The same basic design criteria applies as given above with the exception of vessel diameter and length.

CBI has provided vacuum chamber systems for many major NASA and industrial facilities. An example is shown in Appendix C.

Cryogenic System

When cryogenic tankage is carried in an aerospace vehicle, the tank will act as a heat sink whenever it contains cryogenic fluid. Consequently, large thermal gradients can develop between a cryogenic vessel and the adjoining structure. Even larger thermal gradients will develop as aerodynamic heating occurs during subsequent flight. When aerodynamic heating is encountered, the temperature of the external structure will increase markedly. In the scope of work of this project it is assumed that skin temperatures, especially in the region of leading edges may be as high as 3000°F for hypersonic flight. Meanwhile, the temperature of the cryogenic tankage remains near the boiling point of the liquid that is being contained. Consequently, the thermal gradients that exist immediately before flight will become even more pronounced in the heating regime.

Large thermal stresses can develop. Regardless of how the thermal deformations are accommodated, the effectiveness of the design should be evaluated in a full-scale structure test. The test procedure is relatively straight-forward when the cryogenic liquid in question is chemically inert. Two familiar examples of chemically inert cryogenic liquids are helium and nitrogen. On the other hand, cryogenic fuels used as propellents are by nature chemically active, and to employ cryogenic liquid fuels safely in full-scale high temperature structure tests is a painstaking, costly undertaking.

An important requirement of the proposed High-Temperature Test Facility is the ability to test liquid hydrogen-fueled structures. Liquid hydrogen capabilities are required for dead load and thermal simulation. Cryogenic temperature simulation is important for verification of tank structures and thermal protection techniques.

Liquid hydrogen, the cryogenic material being considered here, is hazardous for three primary reasons (Reference 10). First, a relatively small amount of energy suffices to ignite mixtures of gaseous hydrogen and air. For instance, the ignition energy requirement for hydrogen and air are similar to those for mixtures of gasoline and air. Secondly, mixtures of gaseous hydrogen and air have wide flammability limits. Finally, when hydrogen occupies a confined space, it can detonate, should it become mixed with air and ignited. Hydrogen mixed with oxygen has an even greater tendency to detonate; here detonation can occur even when the mixture is unconfined if ignited.

Extensive aerospace experience over the last thirty years has considerably reduced the risk of handling and storing liquid hydrogen. Care and correct techniques are required, and the preceding discussion explains why cryogenic fuel simulation is a frequently used practice when the fuel is liquid hydrogen.

Liquid nitrogen can, in most cases, be substituted for liquid oxygen for structural testing purposes. Liquid nitrogen is sufficiently inert chemically to present no fire or explosion hazards. Consequently, its low cost and ready availability explain why liquid nitrogen is generally preferred for cryogenic fuel simulation. Unfortunately, liquid nitrogen has several disadvantages for simulating liquid hydrogen. Most of these are caused by discrepancies between important physical properties of

the two liquids. The existence of property discrepancies is not surprising, for many physical properties of liquids are at least roughly correlated with their molecular weights (Reference 11). Since the molecular weight of nitrogen is 28, while that of hydrogen is only 2, considerable property differences would be expected. By this reasoning, helium (molecular weight = 4) might be the best possible hydrogen simulator when physical property resemblance is desired.

However, liquid helium has two important drawbacks, namely high cost and a very low boiling point (-452°F). The low boiling point leads to a requirement for extensive thermal insulation and it also contributes to large losses of an expensive material. Therefore, although gaseous helium is used to simulate gaseous hydrogen, such a simulation is seldom feasible in the liquid regime, at least as far as full-scale tests are concerned.

An especially important problem with nitrogen is its relatively high boiling point (-320°F) compared with that of liquid hydrogen (-423°F). The boiling point difference means that when liquid nitrogen is used, the structure will experience somewhat less severe thermal gradients than are anticipated in actual use. Secondly, the high nitrogen boiling point means that expansion joints, seals, etc., will be tested non-conservatively, i.e., these test conditions will be less severe than expected service conditions. A third consequence of the boiling point difference concerns material embrittlement. It is well known that many metallic and organic materials become embrittled at cryogenic temperatures. The lower the exposure temperature, the more likely it is that embrittlement will take place. When liquid nitrogen is used to simulate liquid hydrogen, embrittlement tendencies are less likely to be detected.

Liquid nitrogen also leaks less readily than does liquid hydrogen. Leakage rates vary inversely with both viscosity and molecular weight. Since liquid hydrogen is less viscous and has a lower molecular weight than liquid nitrogen, its propensity to leak more readily than liquid nitrogen is evident. Owing to its lower viscosity alone, liquid hydrogen leakage will be ten times that of liquid nitrogen (Reference 10). Clearly freedom from nitrogen leakage does not guarantee freedom from hydrogen leakage during actual service.

A general disadvantage of liquid nitrogen cryogenic fuel simulation is that such testing cannot be used to assess the safety of a liquid hydrogen system. Finally, cryogenic fuel simulation offers less protection against design analytical uncertainties and omissions, against human error, etc., than does liquid hydrogen testing.

No really satisfactory simulant for hydrogen has been identified.

The major components of the cryogenic systems (hydrogen, nitrogen, and helium) are shown in Figure 3. The basic system approach used for purposes of estimating costs is patterned after that presented in Reference 9.

As shown in Figure 3, the test specimen tank becomes part of the closed loop hydrogen system. Hydrogen can be transferred to and from the test vehicle and storage dewar by a reversible pressure system with programmed control to simulate fuel usage.

The full-scale test facility (100- by 150-ft chamber) must be capable of handling large quantities of hydrogen and nitrogen. The test Reference Vehicle will carry 156,000 lbs of liquid nitrogen and 935,000 lbs of liquid oxygen. Assuming at least two

gallons of cryogenic material will be required in the closed loop system for every one gallon in the test specimen, liquid hydrogen storage requirements will be 560,000 gallons and nitrogen 300,000 gallons (simulant for oxygen)

For the smaller component test facility (30 ft x 60 ft), liquid hydrogen storage is assumed to be 225,000 gallons and nitrogen 30,000 gallons.

The test specimen tank and/or the storage dewar can be pressurized with gaseous hydrogen (using a vaporizer) to move the liquid to and from the test specimen. Vaporizers and superheaters can also provide gaseous hydrogen for test specimen warmup and cool-down.

Included in the system are both flare stacks for emergency disposal of hydrogen from the test chamber and operational flare stacks for depressurizing and unloading storage dewars. The system also has provisions for rapid transfer of liquid hydrogen back to the storage dewars should leaks develop in the test specimen.

A gaseous helium system is required for purging the hydrogen system prior to filling with hydrogen.

Liquid nitrogen is required for purging the test chamber prior to transferring hydrogen to the test specimen tank; as oxygen simulant in the test specimen tank; for cryopumping for evacuating the test specimen tank; for radiant heater lamp cooling; and for test specimen surface cooling. Again transfer from the test vehicle to dewar is by a reversible pressurization system with gaseous nitrogen using vaporizers.

Budgetary costs for the cryogenic systems are presented in Table 10.

Radiant Heating System

The high-temperature test facility radiant heating requirements based on testing the Reference Vehicle are presented in Section 3.2. Because of high vehicle speeds, very high external surface temperatures, up to 3000°F, must be simulated. The infrared radiant heating system must have automatic programmable closed-loop multiple zone temperature control for real-time simulation of aerodynamic heating.

For purposes of developing a budgetary cost estimate for the test facility, a state-of-the-art tungsten quartz lamp system was assumed. Budget pricing information was obtained from Research Inc. for a lamp system capable of heating 10,000 sq ft of surface area with 700 control channels.

Estimated costs for radiant heating equipment are presented in Table 10.

Costs for installation, electrical wiring, plumbing, support structures, will be test program specific. Rough estimates have been included in Table 10 for completeness.

The proposed state-of-the-art equipment is designed for operation at atmospheric pressure. Special designs may be required for operation in a vacuum. Lamp cooling and corona discharge are two major problems that must be addressed. This will increase costs.

- (1) High heat flux capability required for 500 ft² -- (35 control zones)

Based upon the estimated peak equilibrium temperatures on the surface of the reference vehicle (see Figure 2), it was assumed that the maximum heat flux capability is required over approximately 500-ft² of vehicle surface, i.e., the vehicle nose and the lifting surface leading edges.

To get maximum possible heat flux, Research Inc. recommends the 6-KW halogen cycle tungsten filament quartz lamps (10-inch length) spaced one half inch center to center. This configuration, with approximately 29 lamps per sq ft, is capable of producing 165 Btu/ft²-sec, of which probably a maximum of 100 Btu/ft²-sec can be transferred to the test specimen (assume maximum efficiency between 50-70%). A total of 14,500 lamps is required for the 500-ft² of surface area.

For budget estimating purposes, Research Inc. proposes using Model 5209-10 High Density Modular Radiant Heater elements (see Appendix C - Data Bulletin D518.1B for description of single heater element). Water is used for cooling the reflectors and inert gas must be used for cooling the quartz lamps.

The 500-sq ft area will be divided into 35 individual heating zones (each zone approximately 4 ft x 4 ft). In each zone, power will be regulated to provide the precise desired temperature using thermocouples for temperature measurement and feedback in a control zone. Research Inc. proposes a 3,000 amp Model 650 SCR Power Controller (see Appendix C - Data Bulletin D650.1) for each zone. They further propose the Micristar Temperature Controller (see Appendix C).

The maximum heat flux capabilities may be inadequate for achieving the maximum 3000°F temperature levels. Graphite heaters, as shown in Appendix C, may be required for selected high-temperature zones such as leading edges.

- (2) Moderately high heat flux capability required for 4,500 ft² -- (315 control zones)

Approximately half of the Reference Test Vehicle surface will have temperature levels averaging around 1600°F. For this lower heating requirement, 20 lamps per sq ft is assumed to be sufficient. The maximum lamp output capability is thus 115 Btu/ft²-sec, of which only about 68 Btu/ft²-sec can be transferred to the test specimen surface.

For budget estimating purposes, Research Inc. proposes using High Density Modular Radiant Heater elements similar to the Model 5208-10. Fewer lamps are required, but reflectors, lamp housings and cooling systems are similar to those in the high heat flux zones.

The 4,500 sq ft surface area will be divided into 315 individual, automatically controlled zones. A 2,000 amp Model 650 SCR Controller and Micristar Temperature Controller will be used for each zone.

- (3) Lower heat flux capability required for additional 5,000 ft² -- (350 control zones)

Approximately half of the Reference Test Vehicle surface will have temperature levels below 1400°F. For this lower heating requirement, 15 lamps per sq ft is assumed to be sufficient. The maximum lamp output capability is thus 85 Btu/ft²-sec, of which

only about 50 Btu/ft²-sec can be transferred to the test specimen surface.

For budget estimating purposes, Research Inc. proposes using High Density Modular Radiant Heater elements similar to the Model 5208-10. Fewer lamps are required, but reflectors, lamp housings and cooling systems are similar to those in the high heat flux zones.

The 5,000-ft² surface area will be divided into 350 individual, automatically controlled zones. A 1,500 amp Model 650 SCR Controller and Micristar Temperature Controller will be used for each zone.

Structural Loading System

Simulation of combined stresses from thermal and applied loads dictates that transient heating be accompanied by transient loading. Structural loading system equipment and techniques for simulating aerodynamic and inertial loads are described in Section 4.2.2.

For budget estimating purposes, an automatic closed-loop control hydraulic system capable of providing up to 2,000 gpm at 5,000 psi to 200 servo valves (one serving each 50-ft² of test vehicle surface) is assumed for the large full-scale test facility. A similar, but smaller, system with only 50 load channels is assumed for the smaller component test facility.

For facility costing purposes, the structural loading system is comprised of the three basic subsystems: the hydraulic system, the load control system, and load fixturing.

The major elements of the hydraulic system include electrically driven variable displacement pumps, oil cooling system, interconnecting piping and valving, hydraulic cylinders, servovalves and load cells for applying loads to the test article.

For the load control system, a multi-channel, computer controlled system with auxiliary data acquisition is assumed. It would perform all of the tasks, including monitoring of the loading process to assure that the load spectrum is faithfully implemented, and to protect the test article from damage caused by incorrect load application.

State-of-the-art equipment, with the exception of special water-cooled shrouding of the load cylinders and load cells has been assumed. The system would be capable of meeting Test Facility Requirements for the Reference Vehicle.

Estimated costs for structural load system equipment are presented in Table 10.

Instrumentation

Facility instrumentation components include signal transmission, conditioning, processing and recording equipment as well as those instruments which properly belong to the facility instead of the test specimen.

Temperature

Temperature instrumentation is required both for temperature control and for evaluation of vehicle strain. Test facility requirements (see Section 3.2) specify a need for 4,000 temperature sensors. Of these, we assume that some 2,500 are

required for high-temperature radiant heat control on the vehicle surface. Platinum-rhodium thermocouples with high-temperature sleeving may be required in the high-temperature regions. Other, more expensive thermocouples/techniques may be required in the very high heating regions.

Strain

Test facility requirements specify that capability be provided for measurement of strain at 2000 locations throughout the test vehicle. There has been no state-of-the-art equipment identified which is capable of operating at temperature levels above approximately 1500°F. Special designs will be required.

Deflection

Test facility requirements specify that capability be provided for measurement of deflection at 100 locations throughout the test vehicle. For budgetary cost estimate purposes we assume that a water-cooled housing can be used around each deflection instrument to protect it from the heating environment. We believe that each instrument can be attached to the test specimen by an uncooled quartz rod.

The total cost per location is estimated to be \$20,000 (\$1,000 for deflection sensor, \$10,000 for water-cooled housing, and \$9,000 for the long, slender quartz rod). For 100 units, the cost is then estimated at \$2 million.

Load Cells

Load cells are required as an integral part of the test vehicle loading system. Some 200 have been assumed.

Signal Conditioning

Included in the signal conditioning system are signal conditioners proper, preamps and controllers for signal conditioners and preamps. Descriptions are as follows.

Signal Conditioner Criteria

- ° Programmable gain and band width amplifier per channel (assume MV to volts gain requirement)
- ° Thermocouple signal conditioners contain reference temperature compensation
- ° Excitation voltage per channel provided for all channels except thermocouples
- ° Resistance and voltage calibration for strain gage and deflection sensor channels. Also shorted sensor detection.
- ° Open thermocouple detection on thermocouple channels
- ° Programmable filter
- ° Signal conditioner interconnection cabling (excludes sensor cabling)
- ° High temperature stability

- Bridge completion and automatic balancing of strain gage bridges
- Standard rack mount.

Preamp Criteria

- Preamp per channel
- Programmable gain 1-to-1000X
- Programmable band width 1-to-40-K Hz
- High linearity and stability
- High input impedance
- Remote calibration
- Standard rack mount
- Simultaneous sample-and-hold amplifier per channel.

Controller for Signal Conditioner on Preamp Criteria

- Provides programmable control functions for signal conditioner and preamp; includes setup, calibration, sample-and-hold control
- Digital interfaces

- ° Driver software for controlling functions for signal conditioner and preamps.

Real Time Processing

It is certain that much of the data obtained is needed for control and limiting functions. Required hardware and software for this purpose are functions of many parameters such as numbers of channels, required sampling rates, required accuracy, etc., and these are not known at this time. A very rough estimate of cost has been made in order to arrive at an overall facility cost.

Computers

Computers are required for both data and control, integrating the many interrelated subsystems into a functioning overall system.

Electrical Power Substation

Estimation of required power input to the reference vehicle based upon the specified vehicle surface temperature, assuming the use of tungsten filament quartz lamps with an efficiency of 50% (heat to specimen) and assuming zero back face heat-conduction loss, is approximately 250 MW. Without specific reference vehicle design details, it is not possible to calculate back face heat loss. For purposes of estimating the facility cost, a total input of 350 MW has been assumed. Since the peak usage is of relatively short duration, making the assumption that the substation can operate at somewhat higher loads for brief periods, 300-MW transformer capacity has been assumed.

For the full-scale test vehicle facility, the following equipment has been assumed for the power substation.

- 3 Primary Transformers (100 MW each)
Transformers used to step the 230,000 volt distribution voltage down to 34,500 volts. Costs assumed to be \$9/KVA per General Electric budget estimate.

- 300 Secondary Transformers (5 MW each)
Transformers used to step the 34,500 volt intermediate voltage down to the 480 volt level. Costs assumed to be \$12/KVA per General Electric budget estimate.

- 3 High Voltage Primary Breakers
Costs assumed to total \$500,000 per General Electric budget estimate.

- 300 Secondary Breakers
Cost of each breaker assumed to be \$40,000 per General Electric budget estimate.

Substation equipment costs total about \$33 million. Another \$25 million is assumed for construction and engineering (75% of equipment costs). Construction costs include steel structures, cables, insulators, etc.

Maximum power requirements for the smaller airframe component test facility are assumed to be 45 MW.

Water Cooling System

For the full-scale test facility, a water cooling system must be provided capable of dissipating the estimated 350 MW of power from the radiant heaters. Water cooling is required for the lamp reflectors, the hydraulic loading system, the deflection sensors, and the vacuum chamber. An external water spray system, as shown in Figure 3, is envisioned for cooling the vacuum test chamber.

For budgetary cost purposes, a cooling tower system comprised of two large cooling towers (50,000 gpm each) was assumed. The major components include cooling towers, cooling tower basins, turbine pumps, piping, water treatment system, water storage tank, and pumphouse and cooling tower building. Estimating costs are summarized in Tables 10 and 11.

In addition to equipment costs, power and space requirements are important considerations. Each cooling tower basin will have a footprint approximately 100 ft x 100 ft. An acre may be required to accommodate the entire system. Fan and pump power requirements are estimated to exceed 2,800 horsepower.

Buildings

Costs for a test vehicle fabrication building (150 ft x 200 ft) and engineering test operations building (150 ft x 150 ft) have been included in the facility cost estimates. The latter would house operating controls panels, data acquisition and data processing equipment.

TABLE 10 (continued)

	100 ft Diameter x 150 ft Long		30 ft Diameter x 60 ft Long		Total
	Equipment	Install	Equipment	Install	Total
	(\$ millions)	(\$ millions)	(\$ millions)	(\$ millions)	(\$ millions)
3.0 Cryogenics					
(1) Protective Embankments		2.5		2.25	2.25
(2) Liquid Hydrogen Storage	5.0	0.5	2.0	0.2	2.2
(3) Liquid Nitrogen Storage	1.5	0.5	0.6	0.2	0.8
(4) Gaseous Helium Storage	3.0	0.5	1.2	0.2	1.4
(5) Gaseous Nitrogen Storage	3.0	0.5	1.2	0.2	1.4
(6) Vaporizers and Superheaters	1.5	0.5	0.6	0.2	0.8
(7) Burn Stacks	2.5	1.0	2.5	1.0	3.5
(8) Backup Safety Systems	0.5	1.0	0.5	1.0	1.5
(9) Valves, Piping & Controls	1.0	1.0	0.4	0.4	0.8
(10) Testing & Checkout	0.5	1.0	0.5	1.0	1.5
(11) Hydrogen Sensors, Gauges, etc.	0.5	0.5	0.2	0.2	0.4
		<u>Subtotal</u>		<u>Subtotal</u>	<u>16.6</u>
		28.5		28.5	
4.0 Structural Loading					
(1) Hydraulic System					
◦ Pumps & Oil Cooling					
◦ Servo Valves					
◦ Water Cooled Cylinders					
(2) Load Controllers, Programmer & Data Acquisition					
(3) Hydraulic Power Building					
(4) Misc. (Pressure Lines, etc.)					
		<u>Subtotal</u>		<u>Subtotal</u>	<u>5.0</u>
		11.9		11.9	
		7.5		7.5	
		3.8		3.8	
		0.4		0.1	
		<u>0.2</u>		<u>0.1</u>	
		11.9		5.0	

TABLE 10 (continued)

	100 ft Diameter x 150 ft Long		30 ft Diameter x 60 ft Long		Total
	Equipment	Install	Equipment	Install	Total
	(\$ millions)		(\$ millions)		(\$ millions)
5.0 <u>Cooling Water System</u>					
(1) Cooling Towers					2.0
(2) Cooling Tower Basins					0.2
(3) Water Pumps					0.2
(4) Water Treatment System					0.4
(5) Pumphouse & Cooling Tower Building					2.0
(6) Water Storage Tank					0.2
(7) Miscellaneous					0.5
		Subtotal		Subtotal	5.3
6.0 <u>Instrumentation</u>					
6.1 Instruments					
Temperature (4000)					3.0
Strain (2000)					1.2
Deflection (100)					
sensors, rods, jackets					
Load Cells (200)	2.0	1.0	0.3	0.1	0.4
Signal Conditioning (6300)	1.0	0.2	0.1		0.1
Signal Conditioners					
Preamps	2.9	0.2	0.4		-
Controllers	4.7		0.6		-1.1
Real Time Processing	0.5		0.1		-
Computers	10.0		2.0		2.0
	2.0		1.0		1.0
		Subtotal		Subtotal	24.5
7.0 <u>Test Vehicle Fabrication Building</u>					
(200' x 150')					2.0

TABLE 10 (continued)

	100 ft Diameter x 150 ft Long Equipment (\$ millions)	30 ft Diameter x 60 ft Long Equipment (\$ millions)	Total (\$ millions)
8.0 Engineering Test Operations Building			
(1) Operator Building (150' x 150')	1.5		1.3
(2) Data Acquisition & Data Processing	<u>1.0</u>		<u>0.9</u>
	Subtotal	Subtotal	2.2
9.0 Electrical Power			
(1) Power Substation	33.2	4.0	7.0
9.10.0 Miscellaneous			
(1) Air Compressor Building (40' x 30')	0.1		0.1
(2) Parking (200' x 150')	0.1		0.1
(3) Perimeter Fence & Gates	0.05		0.05
(4) Roads (1625')	0.1		0.02
(5) Dikes (200')	0.25		0.25
(6) Security System	0.1		0.1
(7) Sirens, Emergency Showers, Fire Extinguishers			
(8) Site Preparation	0.1		0.1
(9) Lighting (Building, Test Chamber, Outside Floodlights, Transformers)	0.2		0.16
(10) Emergency Lighting Units	0.1		0.08

TABLE 10 (continued)

	100 ft Diameter x 150 ft Long		30 ft Diameter x 60 ft Long		Total
	Equipment	Install	Equipment	Install	Total
	(\$ millions)	(\$ millions)	(\$ millions)	(\$ millions)	(\$ millions)
(11) Electrical Grounding					0.25
(12) Concrete & Foundations					0.16
(13) Sewers					0.20
(14) Building Heating and Air Conditioning					0.40
(15) Electrical Cable, Wiring, Wiring Trays, Conduit, Excavated Trenches					0.40
(16) Fireproofing, Insulation, Painting					0.16
(17) Structural Steel					0.02
		Subtotal		Subtotal	2.6
					<u>3.4</u>

TABLE 11. SUMMARY OF BUDGETARY COST DATA

(Millions - 1985 dollars)

	100 ft Dia. x 150 ft	30 ft. Dia. x 60 ft
1. Radiant Heating System	45.3	5.6
2. Vacuum System Including Chamber	72.2	13.5
3. Cryogenic System	28.5	16.6
4. Structural Loading System	11.9	5.0
5. Cooling Water System	5.3	1.1
6. Instrumentation	24.5	4.6
7. Test Vehicle Fabrication Building	2.0	0.3
8. Test Operations Building	2.5	2.2
9. Electrical Substation	58.1	7.0
10. Roads, Security, Site Preparation, Lighting, Concrete, Sewers, HVAC, Electrical Cabling, Fireproofing, and Steel	3.4	2.6
11. Miscellaneous (10% of above)	<u>25.3</u>	<u>6.0</u>
	279.0	64.5
Design at 10%	<u>28.0</u>	<u>6.5</u>
	307.0	71.0

Miscellaneous

Estimated costs for items such as site preparation, concrete and foundations, structural steel, roads, dikes, sewers, lighting wiring, etc. are included in the Miscellaneous category in Table 10.

Cost Summary

Total costs for a full-scale high-temperature test facility with a 100-ft-diameter by 150-ft-long test chamber complete with all ancillary equipment are estimated to approach \$307 million. These costs are for a new greenfield installation, not a retrofit of existing facilities. They assume that 350 MW of power are available.

Total costs for a high-temperature airframe component test facility with a 30-ft-diameter by 60-ft-long test chamber complete with ancillary equipment are estimated to approach \$71 million. Again these costs are for a new greenfield installation.

The costs provided above are for separate stand alone facilities. If both a small and a large test chamber were to be incorporated in a single facility, some auxiliary equipment could be shared. Total facility costs would be less than the sum of costs given above.

For the most part, we have assumed state-of-the-art hardware is available in spite of the fact that some equipment is not compatible with the required test environment (especially the 3000°F temperature and the 10^{-6} torr pressure level).

6.0 GOVERNMENT AND INDUSTRY VACUUM AND CRYOGENIC FACILITIES

The initial project scope-of-work called for a determination of government and industry cryogenic facilities adaptable for high-temperature testing of a full-scale aerospace vehicle and vehicle components containing liquid hydrogen. During the course of this study, the scope-of-work was expanded to include vacuum facilities in addition to cryogenic facilities.

Vacuum is one of the important environmental parameters to be simulated. Many thermal protection systems are altitude dependent. Vacuum capabilities are also required when test specimen contains liquid hydrogen for purging air from the test chamber prior to filling with inert gas. Inert gas is required to protect against the event of a hydrogen leak.

The structural test facility and equipment user questionnaire (see Appendix A) sent to industry, research organizations, and government facilities requested information regarding cryogenic and vacuum test capabilities. Information solicited included vacuum chamber sizes, vacuum level capabilities, and liquid hydrogen and liquid nitrogen test capabilities. Again, the screening questionnaire was used principally to determine whether a facility had sufficient capability to warrant further consideration. A more detailed and comprehensive alternate questionnaire entitled Cryogenic Test Facility Questionnaire (see Appendix A) was mailed to facilities known to have cryogenic capabilities. Follow-up contact calls were made to facilities having potential useful capabilities.

The objective of the survey was to identify candidate facilities which might be capable of, or adaptable for, fatigue and static testing of full-scale aerospace vehicles with cryogenic fuels, high temperature, humidity or vacuum.

There are a large number of parameters to be considered when evaluating adaptability of a facility for high-temperature structural testing of full-scale airframes with cryogenic fuels and altitude simulation. Three major issues are:

- (1) Electrical Power Available (very large power requirement).
- (2) Vacuum Test Capabilities
 - ° Vacuum chamber size, shape and orientation
 - ° Minimum test chamber working pressure
 - ° Maximum allowable test chamber working pressure
 - ° Test Vehicle access provisions
 - ° Test chamber provisions for accommodating radiant heating and the accompanying cooling requirements
 - ° Test chamber provisions for accommodating large reactive loading forces.
- (3) Cryogenic Test Capabilities
 - ° Liquid hydrogen storage
 - ° Liquid nitrogen storage
 - ° Vaporizers and superheaters
 - ° Flare stacks, etc.

° Safety considerations.

Survey Findings (Electrical Power)

The radiant heating power requirements are estimated to be as high as 350 MW for the large full-scale test facility and 45 MW for the smaller airframe subscale or component test facility. The larger requirement is equivalent to the entire output from a large power plant. None of the facilities surveyed have this kind of electrical power available.

Additional work is needed to evaluate the feasibility of being able to supply these kinds of power requirements, particularly since they are nonsteady/short-term loads. This may be the single most important consideration in the site selection process. It is possible that there are no facilities or locations where the full-scale test facility power requirements can be provided.

Survey Findings (Vacuum Test Facilities)

Those vacuum test chambers identified in the survey, having at least one major dimension of 20 ft or more, are listed in Table 12. Smaller chambers would not be particularly useful for reference vehicle component testing. Descriptive information obtained from the survey contacts and Reference 12 is provided in Appendix D. Many of the major environmental chambers in this country (those equipped to subject assemblies or subsystems to basic operational conditions of altitude, temperature, and humidity), are described in Reference 12. These facilities were built in the nineteen-sixties to support NASA orbital and planetary flight programs as well as military and commercial satellite and spacecraft vehicles.

TABLE 12. GOVERNMENT AND INDUSTRY FACILITIES WITH VACUUM AND/OR CRYOGENIC TEST CAPABILITIES - SURVEY RESULTS

Facility	Vacuum Test Capability							Vacuum Chamber Description
	Chamber Size	Minimum Pressure	Maximum Pressure	LH ₂ Storage	LN ₂ Storage			
1. NASA Lewis Plum Brook (Space Power Facility)	100' Dia x 121' High	10 ⁻⁸ Torr	1 ATM	Yes	Yes			Appendix D
2. Johnson Space Center (Space Environmental Simulation Chamber "A")	65' Dia x 120' High	10 ⁻⁶ Torr						Appendix D
3. Arnold Engineering Development Center (Mark I Chamber)	42' Dia x 82' High	10 ⁻⁹ Torr	1.7 ATM	No	Yes			Appendix D
4. NASA Lewis Plum Brook (B-2 Spacecraft Propulsion Research Facility)	38' Dia x 55' High	10 ⁻⁸ Torr		34,000 gal*	56,000 gal			Appendix D
5. McDonnell Douglas St. Louis (Space Simulation Chamber)	30' Dia x 35' Long	10 ⁻⁸ Torr	5 psig	No	14,000 Gal			Appendix D
6. McDonnell Douglas Huntington Beach (Space Simulator)	39' Dia Sphere	10 ⁻⁹ Torr	1.0 ATM	No	Yes			Appendix D
7. Martin Marietta Denver, CO	29' Dia x 65'	10 ⁻⁵ Torr	1.0 ATM	10,000 gal.	56,000 gal.			
* 34,000 gal (Railcar)	--			200,000 gal (1/2 mile away)				

TABLE 12 (Continued)

Vacuum Test Capability

Facility	Chamber Size	Minimum Pressure	Maximum Pressure	LH ₂ Storage	LN ₂ Storage	Vacuum Chamber Description
8. Boeing Aerospace Co. (Kent Space Center Simulation Chamber "A")	30' Dia x 40' High	10 ⁻¹⁰ Torr		No	45,000 gal.	Appendix D
9. Jet Propulsion Lab (Space Simulation Chamber)	25' Dia x 85' High	10 ⁻⁶ Torr		No	28,000 gal	Appendix D
10. NASA Langley (60 Foot Simulator)	60' Dia Sphere	10 ⁻⁴ Torr	1 ATM			
11. NASA Langley (55 Foot Chamber)	55' Dia x 55' High	10 ⁻⁴ Torr	1 ATM			
12. General Dynamics Corp. Ft Worth, TX (High Altitude Lab)	35' x 50' x 12'	3.3 Torr	1 ATM	No	Yes	Appendix D
13. Lockheed Corp. Burbank, CA	25' x 60' x 21'	2 Torr	1 ATM	Yes (<1,000 gal)	Yes	
14. Sandia National Labs	10,000 ft ³	0.1 mm Hg	1 ATM	No	No	
15. LTV Aerospace & Defense	15' Dia x 25' Long	10 ⁻³ Torr		No	480,000 SCF	
15. Rockwell International El Segundo, CA	16' Dia x 70' Long	1.2 Torr	1 ATM	5,300 gal	5,000 gal	
17. Grumman Aerospace	19' Dia x 26' Long	10 ⁻⁶ Torr		No	Yes	Appendix D

TABLE 12 (Continued)

Vacuum Test Capability

	Facility	Chamber Size	Minimum Pressure	Maximum Pressure	LH ₂ Storage	LN ₂ Storage	Vacuum Chamber Description
18.	Rockwell International Seal Beach	27' Dia x 30' Long	10 ⁻⁸ Torr				Appendix C
19.	Wright Patterson AFB	No			No	10,000 gal	
20.	NASA Johnson Space Center White Sands Facility	No			Yes	Yes	
21.	Boeing Aerospace Co. (Tulalip Hazardous Test Laboratories)	14' Dia x 20' Long	10 ⁻⁷ Torr		14,000 gal	10,000 gal	
22.	Rockwell International Downey, CA	No			2,500 gal	14,000 gal	
23.	NASA John Kennedy Space Center	No			900,000 gal		
24.	Air Force Rocket Propulsion Laboratory	30' Dia.	10 ⁻⁵ Torr	1 ATM	No	Yes	
25.	NASA Marshall Space Flight Center	15' Dia x 20' Long	10 ⁻⁹ Torr		275,000 gal	8,800 gal	

The Facilities Described Below are Mentioned in Literature but not Surveyed (Current Status Unchecked)

26.	NASA Goddard (Space Environment Simulator)	27' Dia x 40' High	10 ⁻⁹ Torr				
-----	--	--------------------	-----------------------	--	--	--	--

TABLE 12 (Continued)

Vacuum Test Capability

Facility	Chamber Size	Minimum Pressure	Maximum Pressure	LH ₂ Storage	LN ₂ Storage	Vacuum Chamber Description
27. NASA Goddard (Dynamic Test Chamber)	35' Dia x 59' High	10 ⁻³ Torr				
28. Bendix Aerospace	20' Dia x 27' Long	10 ⁻⁸ Torr				
29. General Electric	21' Dia Max.	10 ⁻⁹ Torr				
30. Hughes Aircraft	15' Dia x 36' High					
31. RCA (Princeton, NJ)	24' Dia.					
32. Myle Lab (Huntsville)	10' x 12' x 33'					

Most of the vacuum chambers were built for testing missiles, spacecraft and subsystems in a simulated thermal-vacuum space environment. Most are space simulation chambers designed for testing spacecraft under conditions of extreme cold, high vacuum, and collimated solar radiation. They are typically capable of providing the required 10^{-6} torr pressure level or lower. However, many of the chambers (particularly the larger ones) are vertically oriented vessels, and are not configured to accommodate large structural reactive loads.

No vacuum chamber large enough for full-scale airframe testing (minimum size of 100-ft diameter x 150-ft length) was identified.

The two largest facilities were the NASA Lewis Plum Brook "Space Power Facility" (100-ft diameter x 121-ft high) and the Johnson Space Center "Space Environmental Simulation Chamber A" (65-ft diameter x 120-ft high). Actual available test volumes are smaller than the overall chamber dimensions given above. Both chambers appear to have adequate vacuum capability, and both are large enough for large subscale or component testing if not full-scale testing. There are, however, some serious, yet-to-be-addressed concerns regarding the adaptability of either facility for the proposed high temperature structural testing. Are these facilities able to withstand positive pressures (up to 25 psig) as required for rapid removal of hydrogen from the test chamber should a leak develop (it appears that generally they are not designed for pressure levels above atmospheric)? How would these facilities accommodate large reactive loads? How would these facilities dissipate the enormous quantity of heat generated by the radiant heating lamps? Is adequate power available? Answers to these questions go beyond the scope of work of this study.

There are test chambers with sizes comparable to the specified 30-ft diameter by 60-ft-long component test facility. With respect to their adaptability, many of the same concerns stated above apply. Again, most vessels are not configured for static and fatigue airframe testing.

The NASA Lewis Plum Brook "B-2 Spacecraft Propulsion Research Facility" is one potentially adaptable facility and worth additional investigation. The vacuum chamber (inside clear space: 33-ft diameter x 55-ft high) is large enough for major component testing. The facility is designed for an ultimate vacuum of 5×10^{-8} torr. Unlike most other vacuum test chambers, it will accommodate positive pressures, as required for emergency hydrogen removal, and it has hard mountings for structural reactive loading. In the past a 34,000 gallon railcar has been used for hydrogen storage. The facility also has two 28,000 gallon liquid nitrogen storage tanks. An external rocket engine test stand facility located approximately a half mile away has a 200,000 gallon dewar of liquid hydrogen.

Survey Results (Cryogenic Capabilities)

Large quantities of hydrogen and nitrogen will be required for testing future Air Force aerospace vehicles. For a full-scale airframe test of the reference vehicle, liquid hydrogen and liquid nitrogen storage requirements are estimated to be 560,000 gallons and 300,000 gallons, respectively. In the Reference Vehicle, hydrogen tankage is located in the fuselage. Since test specimen length rather than diameter will be the critical dimension, hydrogen requirements will scale with the length of the test chamber. The 30-ft by 60-ft component test facility is expected to need 225,000 gallons of liquid hydrogen, and 30,000 gallons of liquid nitrogen.

Test facilities having liquid hydrogen and/or liquid nitrogen storage and test capabilities are identified in Table 12.

NASA Kennedy Space Center is the only facility identified with sufficient liquid hydrogen storage and handling capabilities for a full-scale test facility. The principal liquid hydrogen storage areas are at Launch Complexes A and B. At each of these two locations, 900,000 gallons of liquid hydrogen is stored for shuttle launching.

NASA Marshall Space Flight Center reports 275,000 gallons of available hydrogen storage at their Structural Thermal Test Facility. This facility was designed and used for shuttle orbiter thermal protection system verification tests. Nitrogen storage is small and there are no large vacuum chambers.

NASA Plum Brook has a 200,000 gallon hydrogen storage dewar located near the external rocket engine test stands. This might possibly be used in the B-2 Spacecraft Propulsion Research Facility.

Boeing reports that they are presently installing a 14-ft-diameter by 20-ft-long vacuum chamber at one of their Tulalip Hazardous Test Site areas. Plans also call for moving an available 14,000 gallon liquid hydrogen dewar and installing delivery lines at that area. Another site at Tulalip has been used for high-temperature testing of structural components containing liquid hydrogen. It has been used to simulate the boost cycle radiant heat environment on a structure containing liquid hydrogen for a proposed space transportation system.

Hydrogen storage and delivery losses may be a major consideration in test site selection. Kennedy Space Center reports losing

about 450 gal/day by boil off from 900,000 gal of storage. How much liquid hydrogen to store and for how long a period of time are important questions to be answered. Another consideration is the proximity of the test location to a hydrogen supplier because of losses during transportation.

Safety is another critical consideration. On this basis, hydrogen is simply not practical at some test facility locations.

7.0 SUMMARY AND CONCLUSIONS

This report documents the results of a survey to determine the state-of-the-art techniques, equipment and adaptable facilities for testing full-scale aerospace structures. The major findings of this study, including both technological and economic considerations, are summarized below.

7.1 Radiant Heating Test Technology Findings

- ° In spite of the fact that there has been little change in tungsten quartz lamp radiant heater technology in the last twenty years, quartz lamps remain the most practical and popular method employed for large scale thermostructural testing.
- ° No large scale structural testing with tungsten quartz lamp heaters has been reported with test specimen temperatures above 2500°F. Most of the large scale applications have been at temperatures below 2000°F.
- ° Commercial tungsten quartz heater equipment has been designed for atmospheric pressure. No commercial equipment designed for hard vacuum has been identified. Potential problems to be resolved for the use of such equipment in a vacuum include quartz and end seal cooling, electrical arcing, and packaging within the compact confines of a vacuum chamber. Design and development work is needed for large scale high temperature heating with long lamp life in a vacuum environment.
- ° Test specimen outgassing can be a problem. When heating carbon-carbon composite test specimens, quartz lamps become dirty and tend to heat up.

- The maximum practical power density output from commercial tungsten quartz heater systems for large scale applications where long lamp life is required is about 150-175 Btu/ft²-sec. Maximum heat flux density to test specimen is about 100 Btu/ft²-sec. The basic limitation is the number of elements that can be squeezed into a given area while still keeping the lamp end seals from overheating. These rates are for commercial hardware operating in atmospheric pressure environment. Cooling is expected to be more difficult in a vacuum environment, hence maximum output may have to be reduced.
- No commercially available graphite heater equipment has been identified.
- No large scale structural testing with graphite heaters has been reported with test temperatures above 2650°F. Temperature levels up to 6000°F or higher have been reported for small test specimen sizes (a few square feet).
- Graphite heat flux densities of 400-450 Btu/ft²-F have been reported for very small test specimens. More moderate levels of 200 Btu/ft²-sec have been reported for larger scale structural test applications.
- There has been more experience working in a vacuum with graphite heaters than with tungsten lamps. Outgassing characteristics of graphite is a potential problem for hard vacuum operation.

- Automatic programmable closed-loop multiple zone temperature control technology is well developed. Equipment is commercially available with the ability to duplicate temperature as a function of time throughout a flight mission.

7.2 Structural Loading Test Technology Findings

- Commercially available hydraulic loading systems are designed for low temperature/atmospheric pressure operation. No commercial hardware designed for high temperature or hard vacuum has been identified. Methods for thermal protection of hydraulic cylinders, load cells and other structural test system components need to be developed. The impact of a vacuum environment on loading equipment operation needs to be investigated.
- No advanced high-temperature tension pad technology has been reported. For temperatures above 600°F, reported test experience is limited to direct mechanical attachment. Special loading and fixture problems need to be solved for 3000°F applications.
- Automatic programmable, closed-loop multi-zone load control technology is well developed. Equipment is available commercially with ability to duplicate aerodynamic and inertial load profiles as a function of time throughout a flight mission.
- Since the electric power requirements for the radiant heat sources will be large when testing at very high temperatures, special power conditioning and electrical isolation of the load control and data acquisition equipment may be required.

7.3 Instrumentation Findings

7.3.1 Temperature

- ° Thermocouples of suitable materials and application methods appropriate to both the specimen material and the surface temperature expected are probably suitable at temperatures to about 3000°F.
- ° Optical instrumentation is suitable for temperatures above 3000°F but require line of sight from instrument to specimen. Line-of-sight access will generally not be available because the region of the specimen will be crowded with radiant heating devices, load attachments and attachments for deflection sensors.

7.3.2 Strain

- ° There is no strain instrumentation suitable for temperatures to 3000°F. The Boeing/Hitec capacitance gage has a useful upper temperature of 1500°F; the Ailtech weldable gage can be used to 1200°F; and the CERL-Planar capacitive gage can be used to 1200°F.
- ° Battelle-Columbus reports a free-filament gage useful to 2000°F, but significant corrections are required.
- ° Use of strain gages at temperatures approaching their limit requires great care in installation, in attachment of leads, and in calibration.

- ° Other types of strain instrumentation, primarily optical, are under development, but are not yet ready for use.

7.3.3 Deflection

- ° A number of different types of deflection sensors exist which cover the measurement range required. None of these can withstand the high-temperature environment expected in the test chamber, but they could be protected with water-cooled shields.
- ° Connections between the deflection sensor and the specimen can probably be made, possibly with uncooled rods (quartz) or with water-cooled rods.
- ° At least some of these sensors can be expected to operate successfully at vacuums to 10^{-6} torr.

7.4 Vacuum Test Technology and Available Equipment Findings

- ° Outgassing from test specimen materials (i.e., carbon-carbon composites, etc.), insulation, and radiant heating equipment could make it difficult to maintain vacuum levels as low as 10^{-6} torr.
- ° For high-temperature thermostructural testing, a large number of penetrations will be required in the vacuum test chamber to accommodate the electric power, water, hydraulic, cryogenic, control and instrumentation lines required. Sealing may be a problem.

- ° For high-temperature thermostructural testing, the vacuum test chamber must have internal load fittings and be designed to accommodate large structural reactive loadings. Most existing large vacuum chamber facilities (which are typically space simulation chambers) are not configured to accommodate large structural loading.
- ° For high-temperature thermostructural testing, the vacuum test chamber must be designed to accommodate positive pressures for rapid removal of hydrogen pressure buildup should a leak develop. Again, most existing large vacuum chamber facilities are not configured for positive pressures.
- ° There are large vacuum chamber cooling requirements.
- ° There are significant safety considerations that must be addressed.

7.5 Full-Scale High-Temperature Test Facility - Study Findings

The minimum test chamber size requirement is estimated to be 100-ft diameter by 150-ft long.

Radiant heating electrical power requirements for testing the full-scale reference vehicle are estimated to be as high as 350 MW. None of the facilities surveyed have this level of power available. Additional work is needed to evaluate the feasibility of being able to supply such a large power requirement, particularly since peak power will be of relatively short duration.

No existing vacuum chamber test facility large enough for a full-scale airframe test of the reference vehicle has been identified.

For a full-scale airframe test of the reference vehicle, liquid hydrogen and nitrogen storage requirements are estimated to be 560,000 gallons and 300,000 gallons, respectively. NASA Kennedy Space Center is the only existing facility identified with sufficient hydrogen storage and handling capabilities to meet these requirements. Unfortunately, the Space Center does not have the large vacuum test capabilities, the required power or other structural test capabilities needed.

Because of the large quantities of hydrogen required and particularly because of the losses associated with storage and transporting large quantities, proximity of the supplier to the facility will be an important issue in site selection.

A full-scale airframe structure test facility (new greenfield installation) is estimated to cost \$307 million. The electrical switchgear, vacuum chamber system, and the radiant heaters are the major cost items. No existing government, industry or research facilities have been identified which could be modified to provide the desired capabilities for a significantly lower cost.

Test facility operating costs will be very high. Radiant heater operating costs will dominate, but power requirements for vacuum pumps, water pumps, cooling tower fans, and hydraulic pumps will also be substantial.

Test facility space requirements for support system equipment will be an important site consideration. A few acres will be needed for electrical switchgear and cooling towers.

Other important site considerations include large cooling water requirements, safety considerations, and facility availability.

7.6 Component Test Facility - Study Findings

The minimum test chamber size for a component test facility is estimated to be 30-ft diameter x 60-ft long.

Radiant heating electrical power requirements for testing large components of the reference vehicle are estimated at 45 MW. This requirement is large but much more feasible than 350 MW.

Existing vacuum facilities have been identified that might be adaptable for testing components of full-scale airframes containing hydrogen. The NASA Lewis Plum Brook B-2 facility is one example.

For testing components of the full-scale reference vehicle, we estimate that a 40-ft section of fuselage can be tested in the 60-ft-long test chamber. Therefore, hydrogen storage requirements are presumed to be as large as 225,000 gallons. Existing facilities with hydrogen storage capabilities are identified.

The cost for a new greenfield component facility with 30-ft-diameter by 60-ft-long test chamber is estimated to be \$71 million. Unlike the large full-scale test facility, existing test facilities have been identified which offer promise for being adaptable with significant cost savings realized. Additional work is needed to review these options and estimate conversion costs.

REFERENCES

1. Erdos and Morgan, "Professional Mail Surveys," Krieger Publication Co., 1983.
2. Sudman, Seymour and Bradburn, Norman, "A Practical Guide to Questionnaire Design," 1982
3. Dishman, G.A., Hepler, A.K. and Swegle, A.R., "Hot Structures for Lifting Reentry Vehicles," Boeing Aerospace Company, AFWAL-TR-83-3122, January 1984.
4. Schiff, E., "Study of Heating Methods for Structural Testing > 3,000 F," General Dynamics/Convair, WPFDL-TR-65-13, April 1965.
5. Kreider, K. G., Semancik, S. and Olson, C., "Advanced Thin Film Thermocouples," NBSIR 84-2949, October 1984.
6. Telecon with Dr. Donald M. Curry, NASA JSC on 7 July 1985.
7. Boggs, B.C., "The History of Static Test and Air Force Structures Testing," Technical Report AFFDL-TR-79-3071, June 1979.
8. Di Taranto, R.A. and Lamb, J.J., "Preliminary Investigations of Hyper Environments and Methods of Simulation," WADC-TR-57-456, July 1957.
9. Technical Brochure for Liquid Hydrogen/Nitrogen Structures Test Sub-Facility, Building 65, Area B, WPAFB, Ohio, March 1968.

10. Lloyd, D.R. and Murphy, W.J., "Handling Hazardous Materials," NASA SP-5032, Washington, DC, September 1965.
11. Reid, R.C. and Sherwood, T.K., The Properties of Gases and Liquids: Their Estimation and Correlation, Mc-Graw-Hill, New York, 1958.
12. Pirrello, C.J., Hardin, R.D., Heckart, M.V., and Brown, K.R., "An Inventory of Aeronautical Ground Research Facilities, Volume III - Structural and Environmental Facilities," McDonnell Aircraft Company, NASA-CR-1876, November 1971.

APPENDIX A

FACILITY AND EQUIPMENT USER SURVEY FORMS

FLUIDYNE

ENGINEERING CORPORATION

5900 Olson Memorial Highway
Minneapolis, Minnesota 55422

IN REPLY REFER TO

11 October 1985

1445

Subject: High Temperature Structural Testing of Full Scale Aerospace Vehicles

Dear

Fluidyne has a contract with the U. S. Air Force (F33615-84-C-3213), Wright-Patterson Air Force Base, Tim Sikora, Project Engineer, (513) 255-2318, to determine the state of the art of high temperature structural testing of full scale aerospace vehicles. (See attached Air Force letter.) The program includes a survey of elevated temperature structural and other high temperature test facilities to determine appropriate test equipment, test methods, measurement techniques and transducers (temperature, strain, and deflection), and cryogenic facilities for testing full scale aerospace vehicle structures and components to temperatures of 1000°F to 3000°F.

We would appreciate it if you would fill out the attached survey questionnaire and return it to us at your earliest convenience. We have enclosed an addressed, stamped envelope for this purpose. Survey data will aid the Air Force in defining necessary criteria for establishing new structural test facilities or in modifying existing facilities both contractor and government to meet future testing needs.

At this stage in the program, it appears that existing facilities, techniques and instrumentation will be inadequate to permit the Air Force to do the kind of testing they desire and thus a great deal of development work will be required. Information about your facilities, experience and capabilities will help to define the required advancements to the state of the art as well as to establish the priorities for accomplishing these developments.

If you are not the person who can provide us with the information we need, we would be grateful if you would forward this to the appropriate individual.

If you have any questions about this survey, please call me at (612) 544-2721. We appreciate your cooperation in this survey.

FLUIDYNE ENGINEERING CORPORATION

Henry A. Hanson
Project Leader

Attachments
Ez382-L



DEPARTMENT OF THE AIR FORCE
AIR FORCE WRIGHT AERONAUTICAL LABORATORIES (AFSC)
WRIGHT-PATTERSON AIR FORCE BASE, OHIO 45433

29 JUL 1985

REPLY TO
ATTN OF: FIB

SUBJECT: High Temperature Test Technology Study

TO:

1. The Air Force Wright Aeronautical Laboratories has initiated a study investigating the state-of-the-art of high temperature testing. This study will determine manufacturers and suppliers of elevated temperature heat sources and instrumentation. An investigation into industry and government elevated temperature test facilities and their capabilities is also being conducted.
2. The contract to perform this study was awarded to Fluidyne Engineering Corporation with Dr Henry A. Hanson as Project Leader. The attached survey is an integral part of this study. Your cooperation with Dr Hanson and his associates in the collecting of this data will be appreciated and will enable the Air Force to determine current elevated temperature capabilities and to plan for future testing.

A handwritten signature in cursive script, appearing to read "R J Hegstrom".

ROGER J. HEGSTROM, Colonel, USAF
Chief, Structures and Dynamics Division

1 Atch
Survey

HIGH-TEMPERATURE STRUCTURAL TEST FACILITIES QUESTIONNAIRE

TEST FACILITIES: _____ DATE: _____

ORGANIZATION: _____

CONTACT: _____ TELEPHONE NO: _____

1. Have any of your facilities utilized infrared radiant heating equipment?

Yes No

If yes,

What were the applications?

Structural Testing

What were the lamp types?

Tungsten/quartz . . .

Graphite Strip . . .

_____ . . .

What was the highest test specimen surface temperature? _____

2. Have any of your facilities utilized structural load equipment?

Yes No

If yes,

What type of equipment?

Static . .

Fatigue .

What was the highest test specimen surface temperature?

Static Tests . .

Fatigue Tests .

What were the applications?

Aircraft,

What are the maximum available test areas?

For Static Tests: _____ ft x _____ ft Height _____ ft

For Fatigue Tests: _____ ft x _____ ft Height _____ ft

3. Have your facilities employed the following instrumentation?

	Yes	No	Max. Test Specimen Temp.	Manufacturer
Temperature	<input type="checkbox"/>	<input type="checkbox"/>	_____	_____
Strain	<input type="checkbox"/>	<input type="checkbox"/>	_____	_____
Deflection	<input type="checkbox"/>	<input type="checkbox"/>	_____	_____

4. Do any of your facilities have cryogenic test capability? Yes No

If yes, please indicate the type

Liquid Hydrogen

Liquid Nitrogen

5. Do any of your facilities have vacuum test capability? Yes No

If yes,

What is the minimum vacuum chamber pressure? _____

What is the maximum allowable chamber pressure? _____

What is the vacuum chamber size? _____

6. Remarks:

CRYOGENIC TEST FACILITY QUESTIONNAIRE

TEST FACILITY: _____ DATE: _____

ORGANIZATION: _____ TELEPHONE NO: _____

1. Does this facility have cryogenic capability? Yes No

If "yes," please provide the following information:

Liquid hydrogen (LH₂) capacity _____

Max pressure and flow rate _____

Liquid nitrogen (LN₂) capacity _____

Max pressure and flow rate _____

Are vaporizers and superheaters available? Yes No

If "yes," please indicate the following:

	<u>Vaporizer Capacity</u>	<u>Superheater Capacity</u>	<u>Max Temperature</u>
LH ₂	_____	_____	_____
LN ₂	_____	_____	_____

Are gaseous hydrogen flare stacks or burn ponds available? Yes No

If "yes," what are the number and sizes?

2. Does the facility have gaseous nitrogen capability? Yes No

If "yes," what is the capacity and pressure?

3. Does the facility have space which can be used for structural testing a vehicle (which would contain cryogenic liquid)? Yes No

If "yes," what is the available area? _____ ft x _____ ft
height _____ ft

Is there overhead crane capability? Yes No

If "yes," what is the crane capacity? _____

Is there test vehicle access to the test area? Yes No

If "yes," what are the dimensions? _____

What delivery methods are available for a test vehicle (e.g., flatbed)?

What potential is there to expand the test area?

4. What provision is there for personnel safety?

5. Does the facility have radiant heating capability? Yes No

If "yes," please provide the following information:

- Lamp types
- Tungsten/quartz.
 - Graphite strip..
 - _____..

- Reflector surface
- Ceramic.....
 - Copper.....
 - Stainless steel.
 - Aluminum
 - _____

Lamp manufacturers:

Lamp cooling method:

Reflector cooling method:

- Air
- Water
- CO₂
- _____

Total available lamp power _____

Max flux density
(To specimen) capability _____

Test specimen area at
maximum flux density _____

Duration at max flux density _____

Method of power modulation:

- On-off switching
- Variable auto-transform
- Thyratrons/Ignitrons . .
- Solid State
- _____

Method of specimen temperature control:

- Manual control
- Automatic set point
on-off control
- Fully automatic closed
loop using time -
temperature or
other programming . . .

Temperature control transducers:

- Thermocouple
- Fluxmeter
- Optical pyrometer . . .

Number of temperature control channels

6. Does the facility have structural loading capability for aerospace vehicles? Yes No

If "yes," please provide the following information:

Type of loading

- Hydraulic
- Pneumatic
- Mechanical
- Electrical
- _____

Load Control

- Manual
- Automatic time-load program

Maximum loading rate _____

Number of control channels _____

Load control transducers _____

Load attachment methods _____

Maximum specimen temperature _____

Maximum load cycling frequency _____

7. Does the facility have vacuum testing capability? Yes No

If "yes," please provide the following information:

Minimum pressure _____

Time to minimum pressure (from atmospheric) _____

Vacuum chamber size _____

INFRARED RADIANT HEATING EXPERIENCE

1. What lamp/reflector configurations have you used?

Lamp types:

Tungsten/quartz

Graphite strip

Reflector surface:

Ceramic

Copper

Stainless Steel

Aluminum

Lamp manufacturer(s):

Lamp cooling method(s):

Reflector cooling method(s):

Air

Water

CO₂

Total available lamp power:

Maximum dissipated flux density
(to specimen) capability:

Test specimen area at maximum
flux density:

Duration at maximum flux density

2. What control equipment have you used?

- Method of power modulation:
- On-Off Switching
 - Variable Auto-Transform.
 - Thratrons/Ignitrons . . .
 - Solid State.
 - _____

- Method of specimen temperature control:
- Manual Control
 - Automatic Set Point
 - On-Off Control
 - Fully Automatic Closed
 - Loop Using Time
 - Temperature or other
 - Programming

- Temperature control configuration:
- Analog
 - Digital.

- Temperature Control Transducers:
- Thermocouple
 - Fluxmeter
 - Optical Pyrometer.
 - _____

Number of temperature control channels: _____

3. How large a test specimen area have you heated in your facility?

Test Specimen Temperature between 1,000 - 2,000°F	Test Specimen Temperature between 2,000 - 3,000°F
Largest Specimen Area: _____	_____
Time at Temperature: _____	_____

4. Problems and Limitations?

HIGH-TEMPERATURE STATIC AND FATIGUE TEST LOADING EXPERIENCE

1. What high-temperature specimen load attachment methods have you used?

Tension and compression pads:

- Pad material and size _____
- High-temperature bonding materials _____
- High-temperature specimen materials
(pad bonded to) _____
- Maximum test specimen temperature _____

Shear strips:

- Strip material and size _____
- High-temperature bonding materials _____
- High-temperature specimen materials _____
- Maximum test specimen temperature _____

Direct mechanical attachment:

- Attachment method: _____

- High-temperature specimen materials _____
- Maximum test specimen temperature _____

2. What high-temperature loading and transfer linkage have you used?

Type loading:

- Hydraulic
- Pneumatic
- Mechanical
- Electrical
- _____

Type load linkage:

- Loading cables and rods
- Struts and beams
- Sheet metal linkage . . .
- _____

Linkage cooling provisions:

Linkage materials:

Maximum test specimen temperature:

3. What high-temperature specimen load control methods have you used?

Type load control:

Manual control. . . .

Automatic time-load
program.

_____ . . .

Number of control channels _____

4. What high-temperature load control transducers have you used?

Load cells. . .

Deflection . . .

LVDT.

5. Please give the following details on highest temperature test specimen with loading:

Maximum loading rate _____

Maximum specimen temp. _____

Maximum frequency
(load cycling) _____

6. Who designed your test loading systems?

In-house design.

Commercial manufacturer

7. Remarks:

CRYOGENIC TEST FACILITY QUESTIONNAIRE

TEST FACILITY: _____ DATE: _____

ORGANIZATION: _____ TELEPHONE NO: _____

1. Does this facility have cryogenic capability? Yes No

If "yes," please provide the following information:

Liquid hydrogen (LH₂) capacity _____

Max pressure and flow rate _____

Liquid nitrogen (LN₂) capacity _____

Max pressure and flow rate _____

Are vaporizers and superheaters available? Yes No

If "yes," please indicate the following:

	<u>Vaporizer Capacity</u>	<u>Superheater</u>	
		<u>Capacity</u>	<u>Max Temperature</u>
LH ₂	_____	_____	_____
LN ₂	_____	_____	_____

Are gaseous hydrogen flare stacks or burn ponds available? Yes No

If "yes," what are the number and sizes?

2. Does the facility have gaseous nitrogen capability? Yes No

If "yes," what is the capacity and pressure?

3. Does the facility have space which can be used for structural testing a vehicle (which would contain cryogenic liquid)? Yes No

If "yes," what is the available area? _____ ft x _____ ft
height _____ ft

Is there overhead crane capability? Yes No

If "yes," what is the crane capacity? _____

Is there test vehicle access to the test area? Yes No

If "yes," what are the dimensions? _____

What delivery methods are available for a test vehicle (e.g., flatbed)?

What potential is there to expand the test area?

4. What provision is there for personnel safety?

HIGH SURFACE TEMPERATURE INSTRUMENTATION USER QUESTIONNAIRE

Please provide the following information concerning your experience with instrumentation to measure high surface temperatures:

Type of Instrumentation	_____	_____	_____
Manufacturer	_____	_____	_____
Instrumentation Usage	_____	_____	_____
Max Temperature	_____	_____	_____
Surface Material	_____	_____	_____
Method of Attachment	_____	_____	_____
	_____	_____	_____
	_____	_____	_____
	_____	_____	_____
	_____	_____	_____
	_____	_____	_____
Problems including Drift, Durability, etc.	_____	_____	_____
	_____	_____	_____
	_____	_____	_____
	_____	_____	_____
	_____	_____	_____

Remarks :

HIGH-TEMPERATURE STRAIN INSTRUMENTATION USER QUESTIONNAIRE

Please provide the following information concerning your experience with measuring surface strains of materials at high-temperatures:

Type of Instrumentation _____

Manufacturer _____

Instrumentation Usage _____

Max Temperature _____

Surface Material _____

Method of Attachment _____

Problems including Zero Shift, Durability, etc. _____

Remarks:

HIGH-TEMPERATURE STRUCTURAL DEFLECTION MEASUREMENT EXPERIENCE

1. What kind of sensors have you used to measure structural deflection of high-temperature specimens?

<u>Transducer Type</u>	<u>Manufacturer</u>	<u>Model</u>	<u>Deflection Range</u>	<u>Max. Allowable Temperature</u>
----------------------------	---------------------	--------------	-----------------------------	---------------------------------------

2. What methods of cooling and shielding transducers have you used?

3. What methods of attaching sensors to hot test specimens have you used?

4. What is the highest test specimen temperature at which you have measured structural deflection?

5. Remarks:

APPENDIX B

EQUIPMENT SUPPLIER SURVEY FORMS

FLUIDYNE

ENGINEERING CORPORATION

5900 Olson Memorial Highway
Minneapolis, Minnesota 55422

IN REPLY REFER TO

19 September 1985

1445

Subject: Radiant Heating Equipment for High Temperature Application

Fluidyne Engineering Corporation has a contract with the U. S. Air Force (F33615-84-C-3213), Wright-Patterson Air Force Base, Tim Sikora, Project Engineer, 513-255-2318, to determine the state of the art for high temperature structural testing of full scale aerospace vehicles. An important part of the study is a survey to determine the availability of modular infrared radiant heating equipment, techniques, and methods for heating test vehicles and components to temperatures in the range of 1000°F to 3000°F. Survey data will aid the Air Force in defining necessary criteria for establishing new structural facilities to meet future testing needs. Survey data will also help define any advancements to the state of the art which will be required.

We would appreciate it if you would fill out the attached survey questionnaire and return it to us at your earliest convenience. We have enclosed an addressed, stamped envelope for this purpose. The objective is radiant heating equipment for very high-temperature application (to 3000°F). In the event that your equipment has not been used in this regime, we would appreciate any thoughts, ideas, or recommendations that you can offer. Also, if some information can be provided more appropriately with reports or plots, this would be quite acceptable.

If you are not the person who can provide us with the information we need, we would be grateful if you would forward this to the appropriate individual.

If you have any questions about this survey, please call me (612-544-2721). We appreciate your cooperation in this survey.

FLUIDYNE ENGINEERING CORPORATION

Henry A. Hanson
Project Leader

/sjl
Attachments
Ez382-L

FLUIDYNE
ENGINEERING CORPORATION
5900 Olson Memorial Highway
Minneapolis, Minnesota 55422

IN REPLY REFER TO

24 July 1985

1445

Subject: Instrumentation for Measuring Strain at High Temperatures

Fluidyne Engineering Corporation has a contract with the U. S. Air Force (F33615-84-C-3213), Wright-Patterson Air Force Base, Tim Sikora, Project Engineer, 513/255-2318, to determine the state of the art for high-temperature structural testing of full scale aerospace vehicles. An important part of the study is a survey to determine the availability of instrumentation to measure aerospace vehicle structural strain in the range 1000°F to 3000°F. We would appreciate it if you would fill out the attached survey form and return it to us at your earliest convenience. We have enclosed an addressed, stamped envelope for this purpose.

We realize that you may not be able to answer all of the requested items definitively, particularly those on attachment to materials. In that case, we would appreciate your estimates with an indication that they are only estimates. Also, if some item can be answered more appropriately in terms of available plots, this would be perfectly satisfactory. Brochures may also be useful.

Survey data will aid the Air Force in defining necessary criteria for establishing new structural facilities to meet future testing needs. Survey data will also help define any advancements to the state of the art which will be required.

If you have any questions about this survey, please call me (612) 544-2721. We appreciate your cooperation in this survey.

FLUIDYNE ENGINEERING CORPORATION

Henry A. Hanson
Project Leader

/dls
Attachments
Ez382-L

FLUIDYNE
ENGINEERING CORPORATION
5900 Olson Memorial Highway
Minneapolis, Minnesota 55422

IN REPLY REFER TO

25 July 1985

1445

Attention:

Subject: Instrumentation for Measuring Strain at High Temperatures

Fluidyne Engineering Corporation has a contract with the U.S. Air Force (F33615-84-C-3213), Wright-Patterson Air Force Base, Tim Sikora, Project Engineer, 513/255-2318, to determine the state of the art for high-temperature structural testing of full scale aerospace vehicles. An important part of the study is a survey to determine the availability of instrumentation to measure aerospace vehicle structural strain in the range 1000°F to 3000°F. Sometime ago we contacted Eaton Corporation in Los Angeles about high-temperature strain gages. They supplied us with general information concerning Ailtech weldable gages SG 425 and MG 425 and suggested that for further information we should contact Comtel Midwest.

We have developed a questionnaire listing the specific information which we need for the survey and have enclosed a copy. We would appreciate it if you would fill out the attached survey form and return it to us at your earliest convenience. We have enclosed an addressed, stamped envelope for this purpose.

We realize that you may not be able to answer all of the requested items definitively, particularly those on attachment to materials. In that case, we would appreciate your estimates with an indication that they are only estimates. Also, if some items can be answered more appropriately in terms of available plots, this would be perfectly satisfactory. Brochures may also be useful.

Survey data will aid the Air Force in defining necessary criteria for establishing new structural facilities to meet future testing needs. Survey data will also help define any advancements to the state of the art which will be required.

If you have any questions about this survey, please call me (612) 544-2721. We appreciate your cooperation in this survey.

FLUIDYNE ENGINEERING CORPORATION

John J. Casey
Assistant Project Engineer

/pb
Attachments
Ez382-L

FLUIDYNE

ENGINEERING CORPORATION

5900 Olson Memorial Highway
Minneapolis, Minnesota 55422

24 July 1985

IN REPLY REFER 1445

Attention:

Subject: Displacement Sensor Instrumentation for High-Temperature Application

Fluidyne has a contract with the U.S. Air Force (F33615-84-C-3213), Wright-Patterson Air Force Base, Tim Sikora, Project Engineer, (513) 255-2318, to determine the state of the art for high-temperature structural testing of full scale aerospace vehicles. An important part of the study is a survey to determine the availability of instrumentation to measure structural deflection of test vehicle components with temperatures in the range 1000°F to 3000°F.

Future Air Force vehicles will fly at the fringes of the atmosphere at speeds in excess of Mach 10. Vehicle temperatures, particularly surface temperatures near leading edges, will be as high as 3000°F. We are trying to identify instrumentation, techniques, and methods of measuring structural deflection of these hot test vehicles and components. We expect that there may not be any instrumentation available that can be used insitu. It may be possible, however, to position the displacement transducer away from the hot zone and transmit displacement to the transducer via extension rods. If necessary, thermal radiation shields and insulation could be applied to protect sensitive components.

We would appreciate it if you would fill out the attached survey questionnaire and return it to us at your earliest convenience. We have enclosed an addressed, stamped envelope for this purpose. We realize that you may not be able to answer all of the requested items definitively, particularly those on adapting your hardware to high-temperature applications. In that case, we would appreciate any thoughts, ideas, or recommendations that you can offer. Also, if some items can be answered more appropriately with reports or plots, this is quite acceptable.

Survey data will aid the Air Force in defining necessary criteria for establishing new structural test facilities to meet future testing needs. Survey data will also help define any advancements to the state of the art which will be required.

If you have any questions about this survey, please call me (612) 544-2721. We appreciate your cooperation in this effort.

FLUIDYNE ENGINEERING CORPORATION

Henry A. Hanson
Project Leader

/pb
Attachments
Ez382-L

INFRARED RADIANT HEATING EQUIPMENT SUPPLIER QUESTIONNAIRE

ORGANIZATION: _____ DATE: _____

CONTACT: _____ TELEPHONE NO.: _____

Is your company a supplier of radiant heating equipment? Yes No

If you are a supplier, please answer the following.

1. What lamp hardware do you employ?

Lamp Types		Manufacturer
Tungsten/Quartz	<input type="checkbox"/>	_____
Graphite Strips	<input type="checkbox"/>	_____
_____	<input type="checkbox"/>	_____

Lamp cooling method:

Lamp arrangement:

2. What reflector hardware is used?

- Reflector surface:
- Ceramic
 - Aluminum
 - Copper
 - Stainless Steel
 - _____

Reflector cooling method:

- Air . .
- Water.
- CO₂ . .
- _____

Reflector arrangement:

3. Does your company provide control equipment? Yes No

If yes,

What method of power modulation do you use?

- On-Off switching
- Variable Auto-Transform . . .
- Thyratron/Ignitron
- Solid State
- _____

What method of temperature control do you use?

- Manual control
- Automatic setpoint on-off control
- Fully automatic closed - loop using time - temperature or other programming

What is the temperature control configuration?

- Analog
- Digital

What temperature control transducers are employed?

- Thermocouple
- Fluxmeter
- Optical pyrometer
- _____

Remarks:

4. Please give the following details on the highest heat flux density application using your equipment.

What was the maximum heat flux density to the test specimen? _____

What was the maximum heated area (at maximum flux density)? _____

What was the maximum time (at maximum flux density)? _____

What was the maximum specimen surface temperature (at maximum flux density)? _____

5. Please provide examples of high-temperature testing applications where your radiant heating equipment has been employed

<u>Application</u>	<u>Customer</u>
_____	_____
_____	_____
_____	_____

6. What safety provisions are provided with your equipment?

Cooling system failure:

Temperature sensor failure:

Personnel protection:

7. Please provide estimate of radiant heating system costs (cost per kilowatt).

8. Remarks:

HIGH SURFACE TEMPERATURE INSTRUMENTATION SUPPLIER QUESTIONNAIRE

SUPPLIER: _____ DATE: _____

CONTACT: _____ TELEPHONE NO: _____

Does your company supply instrumentation for measuring high surface temperatures (1000°F to 3000°F)? Yes No

If "yes," please provide the following information:

Type of Instrumentation _____ _____ _____

Temperature Range _____ _____ _____

Durability at Max. Temperature _____ _____ _____

Resolution at Max. Temperature _____ _____ _____

Drift (mV vs Time at Max. Temperature) _____* _____* _____*

Cost _____ _____ _____

Method of Attachment for High-temperature Usage:

To Superalloy Metals _____

Max Temperature _____ _____ _____

* Preferably a plot if available

Attachment
Method

_____	_____	_____
_____	_____	_____
_____	_____	_____
_____	_____	_____
_____	_____	_____

To Composites
Such as Carbon -
Carbon Structures*

Max Temperature

_____	_____	_____
-------	-------	-------

Attachment
Method

_____	_____	_____
_____	_____	_____
_____	_____	_____
_____	_____	_____
_____	_____	_____

Remarks:

* Temperature °F	Carbon-Carbon Structure	
	Thermal Coef. of Conductivity, BTU/Hr-Ft-°F	Thermal Coef. of Expansion Inches/inch
1000	4.0 to 7.7	0.002
3000	4.5 to 8.0	0.0075

HIGH-TEMPERATURE STRAIN INSTRUMENTATION SUPPLIER QUESTIONNAIRE

SUPPLIER: _____ DATE: _____

CONTACT: _____ TELEPHONE NO: _____

Does your company supply instrumentation for measuring high-temperature (1000°F to 3000°F) surfaces? Yes No

If "yes," please provide the following information:

Description of Instrumentation	_____	_____	_____
	_____	_____	_____
	_____	_____	_____
	_____	_____	_____
	_____	_____	_____
Temperature Range	_____	_____	_____
Max. Strain	_____	_____	_____
Size of Instrumentation	_____	_____	_____
Durability at Max. Temperature	_____	_____	_____
	_____	_____	_____
	_____	_____	_____
Variation of Gage Factor with Temperature	_____*	_____*	_____*
	_____	_____	_____
	_____	_____	_____

*Preferably a plot if available

Variation of
Zero Shift With
Temperature

_____	_____	_____
_____	_____	_____
_____	_____	_____

Cost

_____	_____	_____
-------	-------	-------

Method of Attach-
ment for High-
Temperature Usage:

to Superalloy
Metals**

Max Temperature

_____	_____	_____
-------	-------	-------

Attachment
Method

_____	_____	_____
_____	_____	_____
_____	_____	_____
_____	_____	_____
_____	_____	_____

Remarks:

* Preferably a plot if available
** For example, Inconel 718 and Rene'41

HIGH-TEMPERATURE DISPLACEMENT SENSOR SUPPLIER QUESTIONNAIRE

ORGANIZATION: _____ DATE: _____

CONTACT: _____ TELEPHONE NO: _____

1. Please list the different types of displacement transducers supplied by your company.

Transducer Type

Displacement
Range

Max Allowable
Temperature

Frequency Response
(HZ)

Type of Output
(e.g. electrical,
visual, etc.)

Size

Cost

2. Please describe how you would make High-Temperature Deflection Measurements: (i.e., where the specimen temperature is higher than the maximum allowable deflection transducer temperature):

3. Please give examples of High-Temperature Testing Applications:

3. Remarks

APPENDIX C

VENDOR LITERATURE



MODEL 5208 HIGH DENSITY RADIANT HEATER

FOR SUSTAINED HIGH TEMPERATURE OPERATION

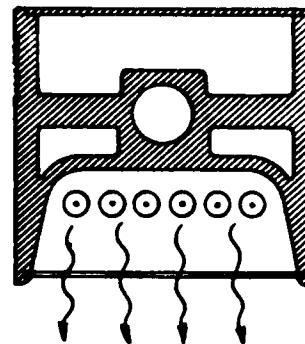
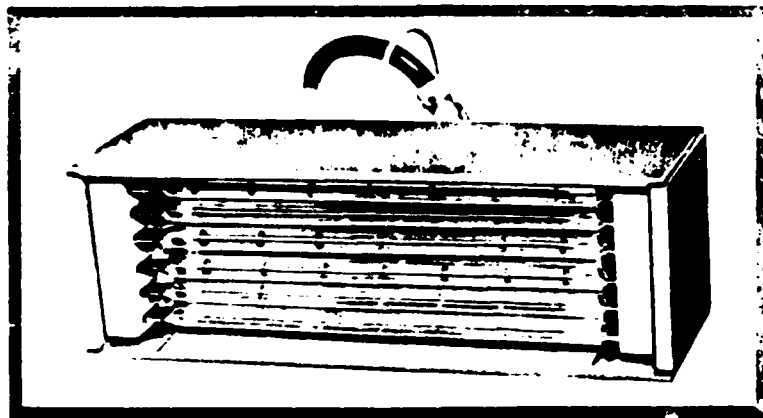

DESCRIPTION

Sustained or variable high radiant heat flux densities can be produced on a workpiece surface by the new Model 5208 High Density Modular Radiant Heater. The unit employs six tungsten-filament tubular quartz lamps type T-3 in compact array to produce up to 100 KW/ft² radiant energy on a workpiece area.

All-component cooling permits sustained operation at high temperature levels. The reflector and case body are water cooled and the lamp chamber, enclosed behind a quartz window, may be air cooled for prolonged life without cooling the workpiece.

Rapid heating rates and high workpiece temperatures can be produced with the Model 5208 Heater (see table below). Available in sizes to accommodate lamp lighted lengths of 5, 10 and 16 inches.

APPLICATIONS

- Fuse ceramic coatings on metals and other substrates (i.e., porcelain enameling.)
- Stress relieve weld joints after welding over large and small localized areas.
- Pre-heat weld joint areas prior to automatic welder head pass in order to achieve greater welding speed with reduced residual weld joint stress.
- Braze sandwich honeycomb panels quickly to reduce grain growth and excessive interior heating of workpiece.
- Anneal continuously moving metal strips.
- Flash-coat tin on sheet metal web to produce a specular finish.
- Add large quantities of heat to a rapidly moving web without introducing additional convection losses, as required for (a) laminated sheet plastic curing, (b) paper dehydrating, (c) heat set ink drying, (d) paper binder curing, and (e) skin delamination.
- Produce instantaneous (i.e. approximately 1/2 second response) heat on sundry specimens in a laboratory.

IMPORTANT FEATURES

FORCED COOLING: Provides maximum trouble-free operating life. Water-cooling of reflector body maintains its high reflectivity and cools the modular case. Air-cooling of the quartz lamps, both tubes and endseals, prolongs their life. A clear quartz window encloses the lamps to prevent the workpiece surface from being convection cooled.

STANDARD SIZES: Choose from three standard sizes to build a high-density radiant heating array. See Specifications on reverse side.

HIGH HEAT-FLUX DENSITIES: Heater module is designed to accommodate six lamps side-by-side to produce highest possible heat-flux density. See table on reverse side.

HIGH WORKPIECE TEMPERATURES: The high heat-flux capability makes very high specimen temperatures attainable. Example: a .02-inch thick sheet Titanium specimen can be heated to 3300°F in 1 1/2 seconds.

COMPACT SIZE: Ideal for (1) use in restricted spaces, (2) grouping together to produce a continuous very-high-density radiant heating panel.

ENCLOSED CASE: The entire modular unit has an enclosed water cooled case to cover all electrical components and thermally hot components.

EASY SERVICING: Unit is designed so that expendable components (e.g. lamps and quartz window) can be installed or serviced.

MANY MOUNTING PROVISIONS: Unit can be mounted by (a) threaded holes, (b) water connections, or (c) air connections

VERSATILITY: Units can be used to surround a wide variety of workpiece shapes to produce both high and low density radiant heat. Low density arrays may be attained by (a) deleting some lamps from the unit, (b) operating lamps at very low voltage. Also, quartz windows may be eliminated for low density applications where lamp envelope heating ceases to be a problem.

RAPID HEATING AND COOLING: Immediate quartz lamp emitter response provides efficient heating within seconds after power is applied (approximately 90% of output in 2 to 3 seconds). Heat output can also be terminated within a few seconds after power is removed, since the reflector body and quartz components are force-cooled.

EXAMPLES OF HEATING RATES

Heating rates are dependent on (1) voltage applied to the heater, (2) specimen or workpiece characteristics and (3) specimen heat loss characteristics. At left are examples of heating rates for a half inch thick specimen (stainless steel with surfaces blackened to increase absorption) indicating the heating rate on each specimen with Model 5208-10 unit operated at rated and double rated voltage. Curve T shows a greater heating rate for a .050 inch thick specimen with double rated voltage applied to heater unit

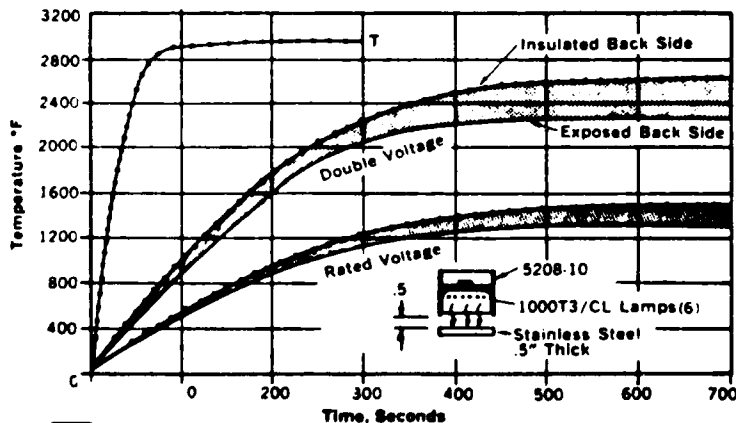

Ø7 DIA POWER KNOCKOUT(2)
AIR EXHAUST

1/8" NPT AIR INLET
Ø10-32 NF (2)
M/G HOLE

PORT "P" PLENUM PRESSURE
MEASUREMENT
Ø1/8" 32 NF TIRE

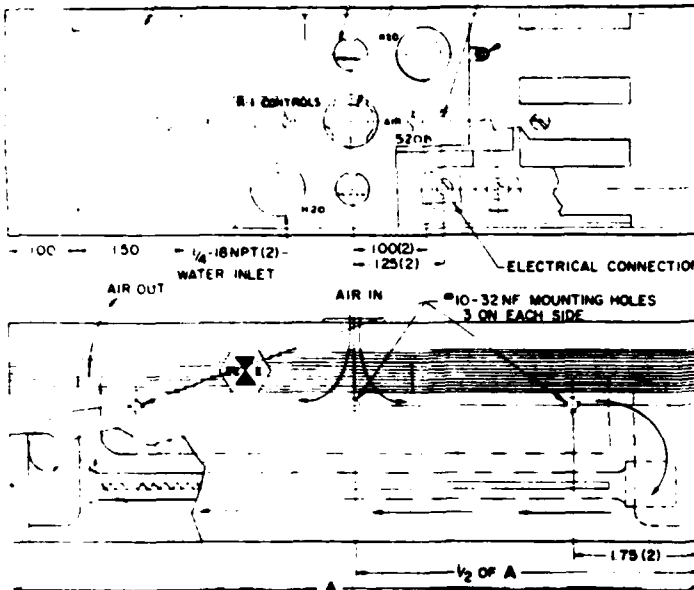

95(2)

315

196

OPTIONAL POWER
CONNECTOR SET

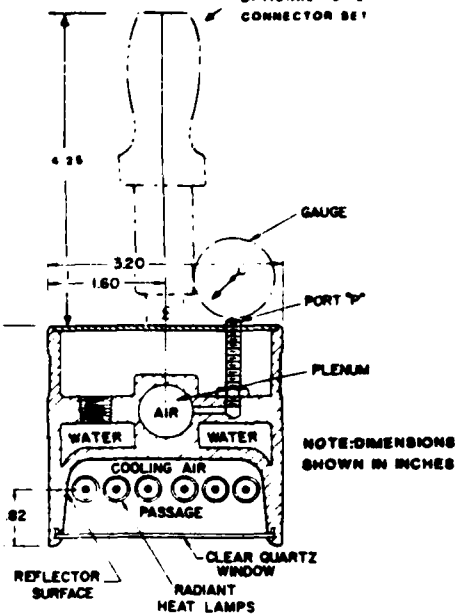

PERFORMANCE DATA

HEAT FLUX DENSITY - Up to 720 watts per square inch at target plane. See heat flux density in table.

POWER RATING - Specifications Table shows power dissipated at rated and double rated voltages. When operating at voltages greater than rated, operate at a reduced duty cycle.

POWER - Power may be hooked up to each side of the lamp bank by removing the two top vented covers to expose the bus bar. Power wiring can enter the unit through one or both of the 5/8-inch diameter knockout holes provided on the top side. Use three conductor 600 volt high temperature insulated wire wired to terminals shown.

SPECIMEN TEMPERATURE - Maximum depends upon (1) high lamp filament temperature and (2) high radiant energy absorption and low heat losses of the specimen. Highest attainable specimen temperature is undetermined; however, 3300°F has been attained on titanium.

SPECIMEN HEATING RATE - Depends upon (1) thermal mass, (2) radiant energy absorption, and (3) heat losses of the specimen. High heating rates are attained when thermal mass and heat losses are low.

EMITTER CHARACTERISTICS - Emitter is a tungsten filament in Argon atmosphere enclosed in a 3/8 inch O.D. clear quartz tube. Emitter operates at approximately 4000°F at rated and 5400°F at twice rated voltage, with .83 and .64 micron spectral energy peaks, respectively. Iodine cycle "Q" lamps operate at 5400°F.

REFLECTOR - Specular aluminum with internal water cooling provision.

SERVICES - Include power, water and air. Power is applied through standard knockout holes. Clean cooling water at 70°F or less at flow rates given in Specifications Table must be provided through the two ports provided as shown in drawing above. Clean cooling air should be supplied at rates given in table.

MOUNTING PROVISION - Fasten the unit to sturdy support bracket via at least two of the six Ø10-32NF threaded mounting holes provided on the unit. Mount units so that the insulated end covers can be removed in order to service lamps. Allow clearance for the hot exhaust cooling air out the slots located on the top of the unit. Unit may also be supported by the water connection fittings (i.e., two Ø1/4-18 NPT ports) or by the cooling air inlet fitting located at the center of the unit.

WATER FOR COOLING - Hook up water for cooling reflector body in and out of the two Ø1/4-18 NPT ports marked H₂O located on the top side of the unit. Use clean water at 70°F or less above ambient dew point at 200 psi maximum. Provide flow rates given on the table shown at right.

AIR FOR COOLING - Hook up shop air to Ø3/8-18 NPT port centered at top side of unit. Provide plenum pressures given on table shown at right. The air should be clean, free from oil, and at 100°F or less. Measure plenum pressure at port "P" with your gauge. The air is used to cool the lamp endseals, lamp envelopes and quartz windows.

INSTRUMENTATION OF WORKPIECE - To measure and control the rapid heating rates attainable with this unit, use a suitable rapid-responding temperature sensor such as a thermocouple junction fastened directly to the specimen.

SPECIFICATIONS

MODEL NUMBERS		5208-5		5208-10		5208-16		
Overall Length, A		9.50 (24.13)	12.63 (32.08)	12.63 (32.08)	18.63 (47.32)	18.63 (47.32)	18.63 (47.32)	
Dimension B connector option		4.0 (10.16)	7.1 (18.03)	7.1 (18.03)	13.1 (33.27)	13.1 (33.27)	13.1 (33.27)	
Weight, pounds		8	12	12	17	17	17	
L A M P S (not included)	Type	500T3 T/CL	1200 T3/CL T/NT	1000 T3/CL T/NT	2000T T3/CL T/NT	1600T T3/CL T/NT	3200T T3/CL T/NT	
	Lighted Length, Inches (cm)	5.00 (12.70)	6.00 (15.24)	10.00 (25.40)	9.75 (24.77)	9.75 (24.77)	16.00 (40.64)	15.75 (40.01)
	Rated Voltage, Volts	120	144	240	240	480	240	384
Total Power Dissipated at Rated Voltage, kW		3.0	7.2	6.0	12.0	36.0	9.6	19.2
Total Power(1) Dissipated at 2x Rated Voltage, kW		8.1	19.4	16.2	32.4	(4)	25.9	51.8 (13)
Net Heat Flux at Window Surface at Rated Voltage, Watts/in ²		123	246	130	260	780	133	266
Net Heat Flux at Window Surface at 2x Rated Voltage, Watts/in ²		333	666	349	699	(4)	360	720
Current at Rated Voltage, Amperes		25	50	25	50	75	40	50
Cooling water Flow(2) Recommended, GPM		.2	.6	.5	1.0	1.1	.8	1.4
Cooling Air(2) Recommended	Plenum pressure at port "P", psig	7	12	11	15	23	13	19
	Flow, CFM	14	26	23	25	31	26	19
NOTES: (1) Operator above rated voltage to 2x rated voltage is permissible for transient heating only. (2) Lesser flow rates are permissible when duty is reduced. Greater flow rates are always better. (3) Voltages above 480 are not recommended in this unit. (4) Do not operate above rated voltage. * Horizontal operation only.								
ORDERING EXAMPLE	5208	-10	Basic Model	-10	Lighted Length	(Order lamp separately from above table)		



PHASER
MODEL 64600



DATA-TRAK
MODEL 6310



THERMAC
MODEL 625

CLOSED-LOOP TEMPERATURE CONTROL

Standard THERMAC® Temperature/Power Controllers and DATA-TRAK® Curve-Following Programmers offer practical, high-performance closed-loop temperature control for both static (setpoint) or dynamic (programmable) heating conditions. PHASER® Proportional Power Controllers are ideal for manual open loop control.

*Trademark of Research, Inc., Minneapolis, Minnesota



RESEARCH INC

BOX 24064 MINNEAPOLIS MINNESOTA USA 55424

PHONE (612) 941-3300

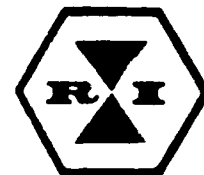

PROCESS CONTROLS DIV.
RESEARCH INC

THREE PHASE SOLID STATE SCR POWER CONTROLLER Model 650

BASIC FEATURES

- PHASE-LOCK-LOOP FOR LINE NOISE REJECTION AND ABSOLUTE TRACKING
- DISTRIBUTED ZERO CROSS, ZERO CROSS OR PHASE ANGLE CONTROL
- MODULAR DESIGN
- ONE BOLT SCR HEATSINK MOUNTING (AIR)
- AIR OR LIQUID-COOLED
- VOLTAGE REGULATION
- AUTOMATIC FREQUENCY SYNC (45-65 Hz)
- INPUT/OUTPUT LINEARITY (STANDARD)
- SWITCH SELECTABLE INPUT SIGNALS
1-5 Ma, 4-20 Ma, 10-50 Ma, 0-5 VDC
- PLUG-IN TIMING BOARD, GATE BOARDS, OPTIONS
- OUTPUT SIGNAL CONDITIONING FOR LOAD MATCHING
(HEATERS, TRANSFORMERS, INCANDESCENT)
- EASY ACCESS TO FUSES
- 1T FUSES STANDARD (EXCEPT WITH ICT)
- HOCKEY PUK SCR
- 2 LEG. HYBRID, 6-SCR OR INSIDE DELTA CONTROL
- 19" WIDE SNAP OFF FRONT COVERS
- SIZES AVAILABLE TO 830 KVA
- DC ELIMINATION OPTION

DESCRIPTION

Model 650 offers three basic modes of electrical power control for industrial or commercial applications — PHASE ANGLE, ZERO CROSSOVER, and DISTRIBUTED ZERO CROSSOVER. Controllers accept low level input signals and proportion power to the load linearly with respect to the input.

A unique PHASE-LOCK-LOOP controls the phase to phase SCR firing and provides extremely accurate timing. AUTOMATIC FREQUENCY SYNCHRONIZATION eliminates all frequency stability problems. SCR gate voltages are isolated.

VOLTAGE COMPENSATION establishes the 650 as a constant voltage controller eliminating a droop in process when the line voltage changes. CURRENT COMPENSATION closes the loop internally on current providing constant current to the load.

Output (0-100% of E RMS) is linear with respect to an input signal (0-100%) or with respect to manual setting.

Our Model 650 is only 19 inches wide and is modular in design. All components are plug-in or mounted for easy access and quick replacement. It accepts all standard input signals.

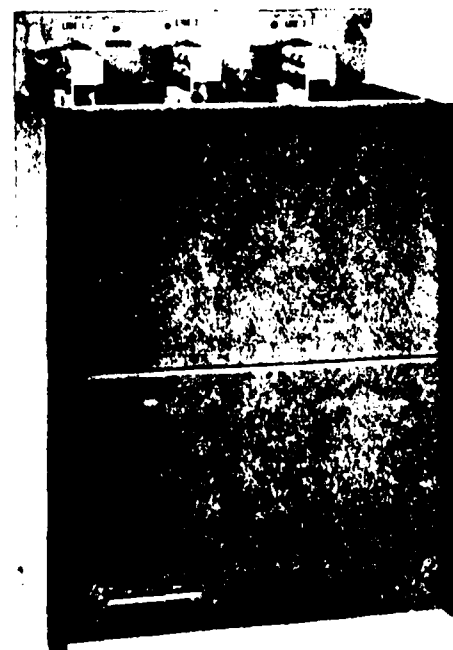

APPLICATIONS

- OVENS AND AUTOCLAVES • TRANSFORMERS AND INDUCTIVE LOADS • DIRECT RESISTANCE HEATING • TUNGSTEN LAMPS • NICHROME ELEMENT FURNACES • MOLYBDENUM ELEMENT FURNACES • SILICON CARBIDE ELEMENT FURNACES • PORCELAINIZING FURNACES • ELECTRODE BOILERS • GLASS MELTING FURNACES • CHAMBER HEATERS • HUMIDITY STEAM GENERATORS

8 0 0 0

DIGITAL CONTROL PRODUCTS

- Micristar™
- Micricon™
- Micrhost-IDC

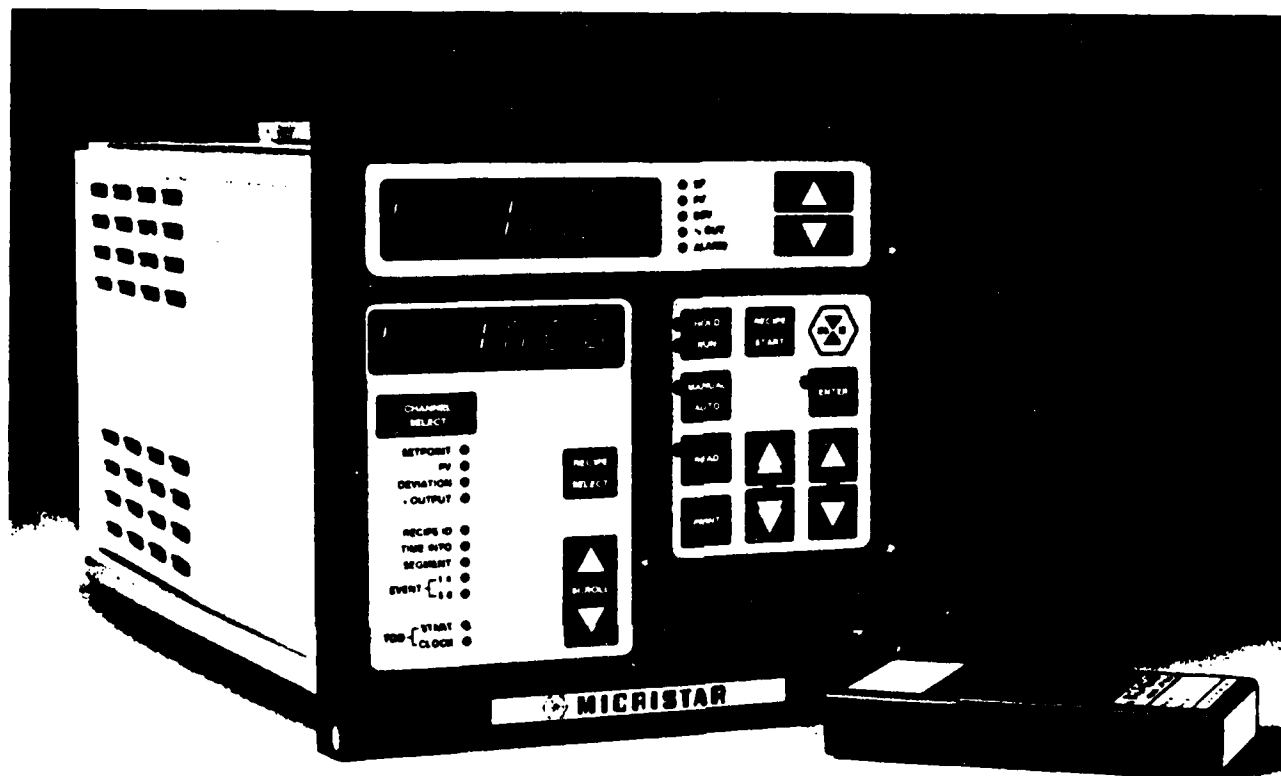

Micristar™

Micristar offers a significant advance in digital process control technology. It is a full-featured controller/programmer, specifically designed to provide solutions to a variety of industrial process control problems. Micristar can be configured as a simple, single-loop controller to manipulate the variables of both batch and continuous processes, or it can be supplied as a one-or two-loop programmed set point controller. It can also be integrated into a distributed intelligent network with centralized communications and overall process supervision and

management. Micristar is field configurable by plug-in modules, and via the Command Cartridge, Micristar is easily loaded for a variety of program data recipe selections. Micristar has both local RS232 and an RS422/RS423 communications ports to permit local alarm recording and data base printing and centralized process supervision and management. This exceptionally user-friendly instrument provides a more favorable cost/performance comparison between digital process controllers comparably priced but with fewer features.

- Applications: Batch process control • Continuous process control
 • Programmed setpoint control • Distributed networking
 • Product testing • R & D

MCDONNELL AIRCRAFT COMPANY

MCDONNELL DOUGLAS



ENGINEERING AND RESEARCH
TECHNICAL FACILITY DESCRIPTION

Thermal Structures Laboratory

The Thermal Structures Laboratory conducts thermal or thermal/structural tests on components of spacecraft, missiles, and aircraft requiring a controlled temperature environment simulation for complete evaluation. The laboratory consists of multiple channels of silicon controlled rectifier power controllers combined with programmed temperature controllers. This equipment provides the capability of imposing time based simulation of aerodynamic or solar heating profiles over large complexly shaped surfaces and can include the simultaneous application of structural loads. Graphite element radiant heaters and infrared quartz lamps are the primary heat sources, with controlled temperature fluids and thermal blankets frequently used. Recent experience includes tests of the Advanced Strategic Air Launched Missile, in which aerodynamic and engine heating profiles were combined with launch and aerodynamic induced structural loads. Past experience includes thermal/structural tests of Space Shuttle oriented thermal protection systems.

Operational Characteristics

- Power Capacity 2,160 kVA for 30 sec
1,080 kVA Continuously
- Temperature Capability Less than ambient to 4,000°F.
Maximum Rate 350°/Second
- Maximum Heat Flux 200 Btu/ft²Sec
- Control Channels 9 Channels of Portable Power units can be utilized at laboratory locations remote from the Thermal Structures Facility.
- Available Test Area 90 x 150 ft reinforced floor structural test area
- Air Supply 4 in. Dia. Line @ 600 psi
- Liquid Nitrogen 3 in. Dia. Line @ 100 psi

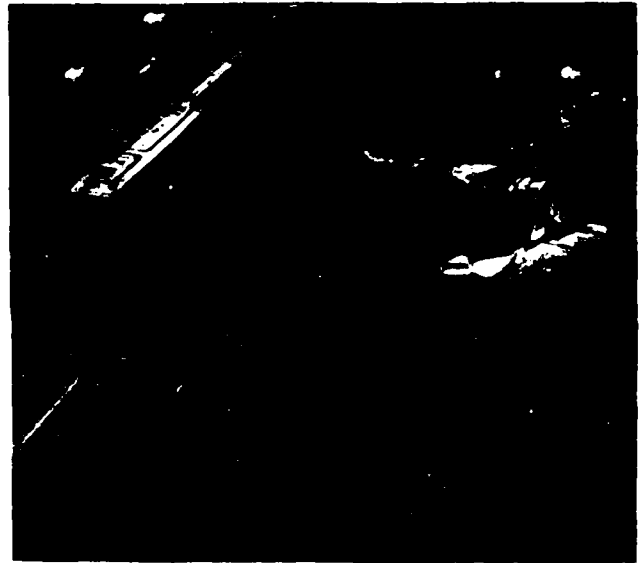

GRAPHITE RADIANT HEATING ARRAY FOR SHUTTLE WING LEADING EDGES.

Applications

The Thermal Structures Laboratory is used to subject various aircraft, missile, and spacecraft components to the laboratory simulated environmental effects of aerodynamic heating and loading, similar to those encountered during launch, reentry, or high Mach No. flight. The facility is also used for test programs requiring combined environments such as thermal/vacuum or thermal/vibration/acoustic. In addition, it is used to evaluate high temperature resistant coatings, insulations, mechanical properties of materials, elevated temperature curing, or heat treating.

Instrumentation

- Modular Data System provides capabilities for recording up to 1,024 channels of data on magnetic tape, on-site tabulation, and automatic data tabulation for post test evaluation.
- Portable data monitoring and recording equipment provides up to 100 channels of information.

FACILITY LOCATION	DEPT NO 253	BUILDING NO. 10
CITY St. Louis	STATE Mo	



THERMAL VACUUM CHAMBER

For Rockwell International At Seal Beach, California

PHYSICAL CHARACTERISTICS:

- Size:** 27' ϕ OD x 30' long cylinder.
- Door:** Truncated end bell, side hinged.
- Personnel Door:** 3'6" W x 6'6" H located in the main door.
- Material:** 304 stainless steel shell with A36 and A283C carbon steel stiffeners.

VACUUM CAPABILITIES:

- Ultimate Pressure:** 1×10^{-8} torr with the thermal shrouds cold.
- Roughing System:** 2 stage, 3 train, air cooled system. 3000 CFM nominal 1st stage, 1500 CFM 2nd stage. 90 minute pump down to 2×10^{-1} torr. Controlled pump down of 5 torr per minute to 50 torr.
- High Vacuum System:** 6—48" ϕ cryopumps (240,000 liters per second total for N₂).
 Chamber isolation valves provided for each cryopump.
 1—1000 L/sec air, air cooled turbo-molecular pumping system.

THERMAL CAPABILITIES:

- Shroud:** Cylindrical, single circuit aluminum extrusion, open shroud with 11 independent zones. Optically dense to the work space. Boiling LN₂ system.
- Test Space:** 25' ϕ with 20' W x 30' L flat work space floor.
- Shroud Temperature Range:** -320°F with a boiling liquid nitrogen system. -297°F (90°K) with 40 KW heat load concentrated on any 25% of shroud. Warm-up from -320°F to 50°F with gaseous nitrogen in 4 hours with recirculating system using a 150 HP stainless steel blower and a 125 KW heater.

CONTROL & DATA ACQUISITION:

Complete Computer Control of all Vacuum, Thermal and Test Operations and Data Logging.

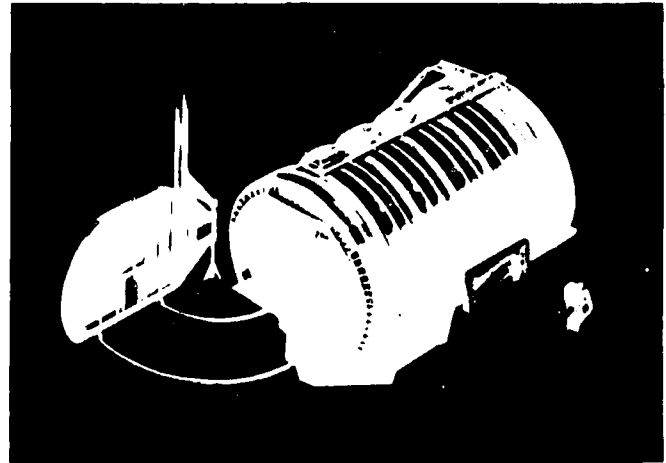

Three separate computer trains, provided for data and operations with a fourth computer to supervise and furnish central data logging and thermal analysis. All four computers intercommunicate or operate independently. All critical operations can be accomplished through any machine.

- Statistics:** 2000 thermocouples, 140 analog and 600 digital data and operational points; 9 color CRT/KBD 4 B&W CRT/KBD, 49.5 megabyte of disc storage, 71 megabytes RAM, 5 tape storage units, 6 printers, one color plotter, complete software, complete graphic panel, full hardware, manual override.

AUXILIARIES:

Controlled rates of repressurization with gaseous nitrogen or air. An exhaust blower is used to provide a breathable atmosphere in the chamber after a GN₂ repressurization and to provide conditioned air to the chamber while working in the chamber setting up a test. The system is supplied with an oxygen analysis system to monitor the building and chamber oxygen levels.

A temperature controlled quartz crystal microbalance and a residual gas analyzer are provided to determine the composition of air and contaminants in the chamber.

A thermally controlled test vehicle handling and moving fixture is provided to move test vehicle into and out of the chamber.

A high vacuum compatible TV system is installed in the chamber. A wireless communications system is provided for the system operating personnel.

APPENDIX D

VACUUM CHAMBER FACILITY DESCRIPTIONS

NASA LEWIS RESEARCH CENTER -- PLUM BROOK STATION
SPACE POWER FACILITY

The Space Power Facility (SPF) of the NASA-Lewis Research Center is located on the 8,000 acre Plum Brook Station 5 miles south of the Lake Erie port of Sandusky, Ohio and 56 miles west of Cleveland. It is the largest controlled-environment test chamber in the world. The most attractive feature of this facility is the versatility of its ancillary systems in providing a test configuration and environment peculiar to the needs of the particular program involved. Solar and thermal simulation systems are not fixed in the facility but can be adapted to fit required test geometry. The size of the test chamber and its associated shop, assembly, and disassembly areas, its remote location on the Plum Brook Station, and the inherent capability of related Station facilities and equipment are the mixture of ingredients which mark it as a truly national test facility. Programs having need of either a wide range of pressures down to hard vacuum, a range of temperatures from outer space to atmospheric ascent condition, controlled gas composition, etc., or having specialized needs such as clear distance, large volume, solar simulation, contamination simulation or control, etc., can be accommodated.

FACILITY DESCRIPTION

The basic facility consists of a 100-ft diameter by 121-ft high vacuum chamber, large assembly/shop area, clean room, disassembly area (shielded test support area), test control center, office building, cryogenic and vacuum equipment areas plus associated facility and test support systems. Installation and removal of test articles is facilitated by two 50-by 50-ft doors and three railroad tracks which run through the chamber and adjoining high bay areas. These high bay areas are themselves useful test facilities.

TEST CHAMBER

Test Chamber Concrete Enclosure:

Inside Diameter	130 ft
Inside Height	150 ft

Aluminum Test Chamber:

Inside Diameter	100 ft
Inside Height	121 ft

NASA LEWIS RESEARCH CENTER -- PLUM BROOK STATION

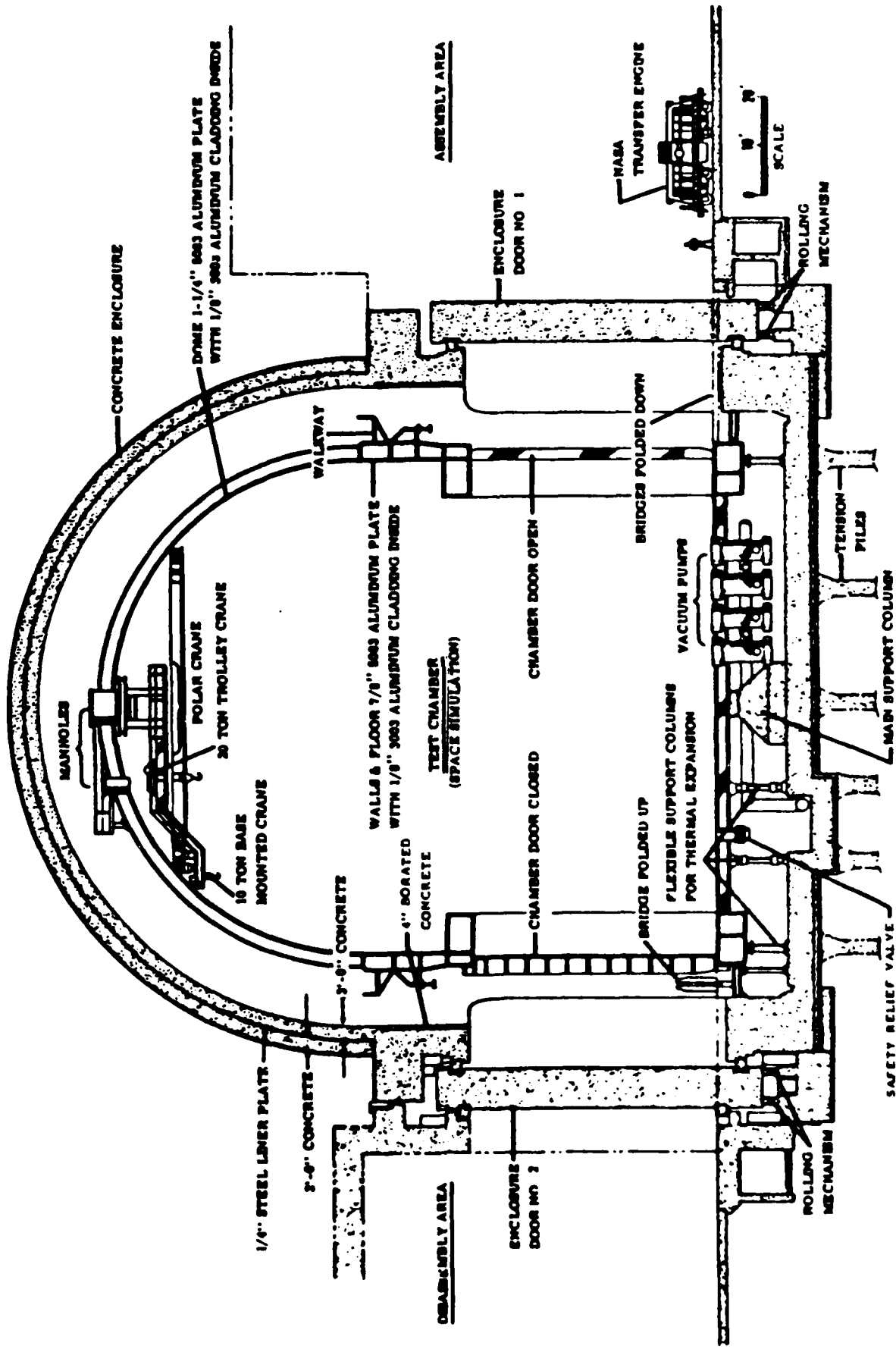

Space Power Facility
 Elevation Cross-Section

NASA JOHNSON SPACE CENTER
SPACE ENVIRONMENTAL SIMULATION CHAMBER A

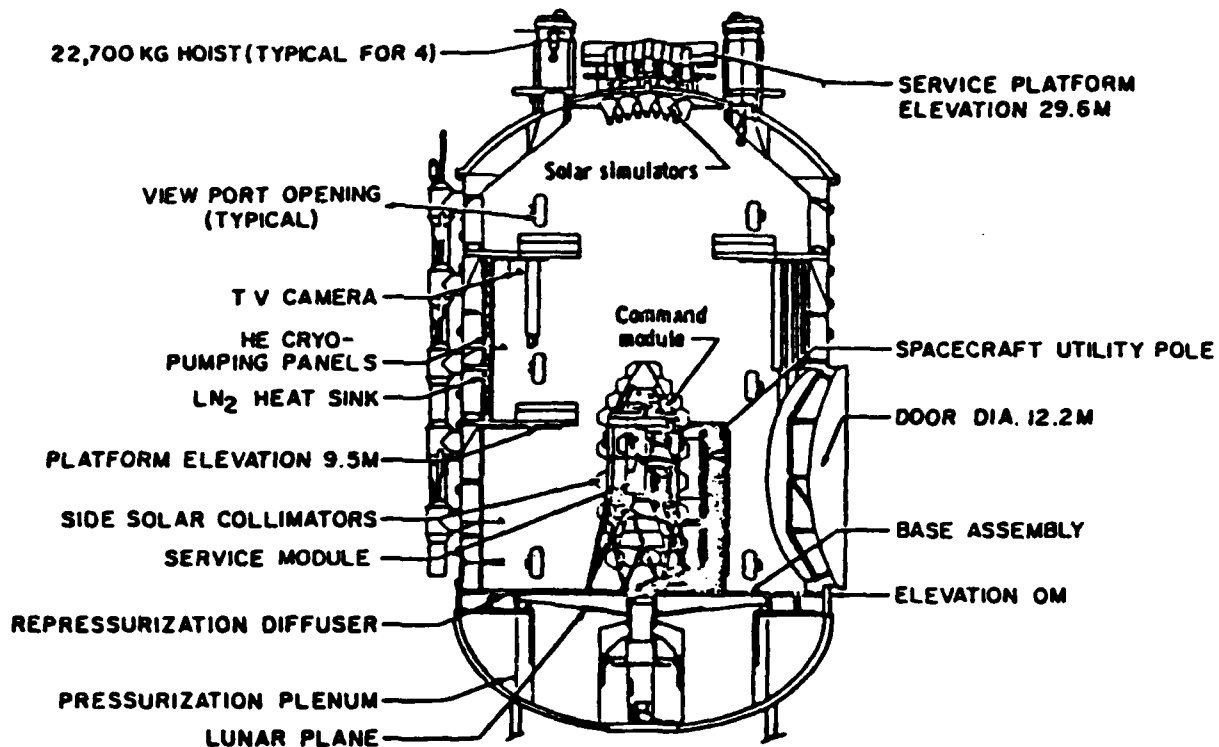

DESCRIPTION

This chamber is collocated with Chamber B in the Space Environment Simulation Laboratory (SESL) and shares major ancillary systems and supporting facilities with that chamber. (Chamber B is described in the following resume.)

The 19.8-m-diameter x 36.6-m-high stainless steel vacuum vessel provides a working volume within a 90°K heat sink shroud of approximately 16.8 m x 27.4 m. Primary access is through a 12.2-m-diameter hinged side door. A modular system of carbon arc solar simulators provides a vertical, 4-m-diameter solar field beamed downward from the top of the chamber and a 4-m-wide x 10-m-high one beamed horizontally from the side of the chamber. Solar intensity is variable from 0.5 to 1.0 solar constant; uniformity is $\pm 20\%$ and the decollimation half angle is 50 min. The floor of the chamber on which test fixtures may be mounted will sustain a load of 90,800 kg; it may be rotated during tests to provide real-time directional cycling of the side sun. A system of mechanical roughing pumps, 20°K cryopumps, and valved-oil diffusion pumps provides a pumping capacity of 20 torr-liters/sec for condensable gases and 0.3 torr-liters/sec for noncondensable gases at a pressure of 1×10^{-6} torr. Usual chamber inleakage is less than 8 torr-liters/sec air. Time to reach thermal-vacuum test conditions is 7 hr.

Several special equipment features and procedures provide an exceptionally low particulate and molecular contamination environment for tests of sensitive hardware. Real-time and near-real-time monitoring of the contamination environment during test is provided by several complementary types of special instrumentation. Man-rated capability is supported by 2 sets of 4-m-diameter x 4.6-m-long double man locks, one pair at ground level and the other located 9.5 m above. Other man-rated features include an emergency repressurization system; facility environmental control breathing systems; a 6-man hyperbaric chamber; and suiting, prebreathing, and emergency medical treatment facilities.

ARNOLD ENGINEERING DEVELOPMENT CENTER

Aerospace Environmental Chamber (Mark I)

GENERAL DESCRIPTION

The Aerospace Environmental Chamber (Mark I) consists of a large vertical cylindrical vacuum tank, pumping systems, thermal environment systems, vehicle support and attitude control equipment, controls, and instrumentation suitable for conducting tests on large space vehicles. A schematic of the facility is shown in Fig. 8.1, and the chamber and associated equipment areas are shown in Fig. 8.2. The building which houses the chamber has ten working floors—four below and six above ground. The chamber is contained in a room 68 by 68 by 109 ft high. Service areas within the building provide space for test article buildup and for maintenance of related equipment.

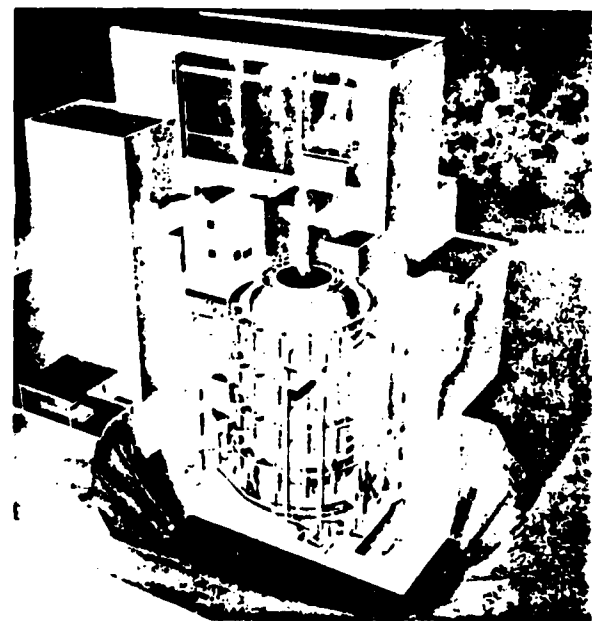

Mark I Facility Arrangement

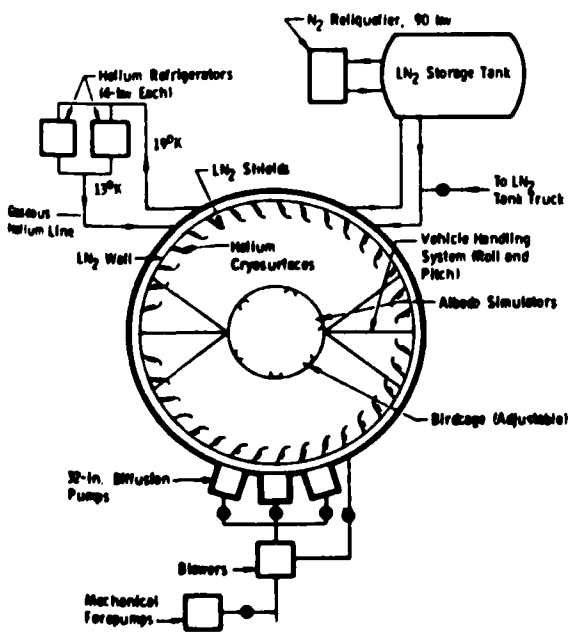

Mark I Schematic

ENVIRONMENTAL CHAMBER

The Mark I environmental chamber is a 42-ft-diam, 82-ft-high, cylindrical vessel with 0.875-in.-thick walls and 1.5-in.-thick elliptical heads. The chamber shell is constructed of 304L stainless steel for minimum outgassing and good corrosion resistance. Five circumferential walkways, equally spaced vertically, surround the chamber for ready access in operation and maintenance.

The nominal inside working dimensions of the chamber are 34 ft in diameter and 65.5 ft in height. With minor rearrangement of the internal cold surfaces, a vehicle 72 ft long can be accommodated. Vehicle entrance to the chamber is

NASA LEWIS RESEARCH CENTER -- PLUM BROOK STATION
SPACECRAFT PROPULSION RESEARCH FACILITY (B-2)

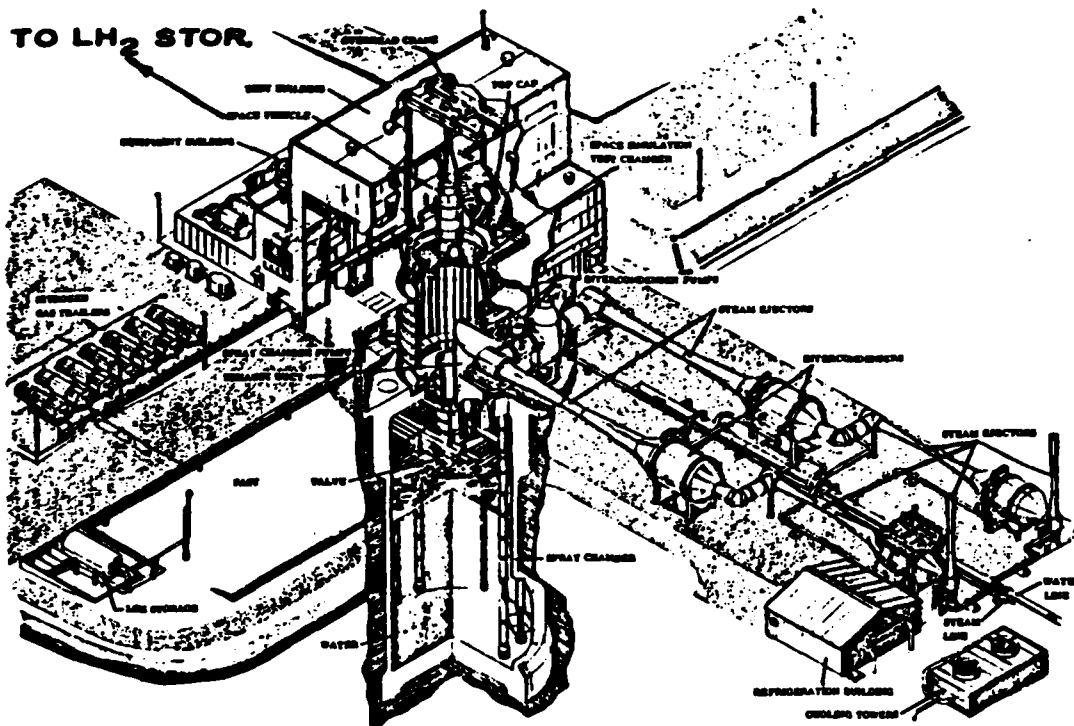

DESCRIPTION

This facility is capable of simulating vacuum, cryogenic temperatures, and thermal radiation for test packages up to 22 ft in diameter and 50 ft high, and for firing sequences up to 380 sec with a vacuum start.

The following major elements comprise the facility: a test building, an equipment building, a 3-stage exhaust system, a waste treatment retention pond, propellant oxidizer and fuel storage, an electrical substation, a refrigeration system, and a service building. Major support components or equipment includes a control center (located in "B" control building), a steam plant, and steam accumulators.

The vacuum test chamber has the following capabilities:

Vacuum Space Soak: 5×10^{-6} torr

Cold Wall: -320°F

Radiant Heat: 130 W/ft², maximum intensity

Chamber (inside clear space): 33 ft diameter x 55 ft high

LN₂ Capacity: 200 gal/min, maximum flow.

The exhaust system has a capacity of 1550 ft³/sec at one psia; the 3-stage steam ejector has a steam rate of 348 lb/sec.

manned tests. All compartments are equipped with radio frequency and hard line communications equipment.

Applications

- Full-scale thermal-vacuum testing of spacecraft and subsystems
- Manned altitude tests for spacecraft system verification, crew training and crew/system integration

Associated Equipment

Cryogenic and High Pressure Test Facility

This facility, used for servicing and testing both cryogenic and high-pressure systems, is located next to the chamber area. The facility is equipped to handle hydrogen, oxygen, and nitrogen in both the liquid and gaseous forms. Test and servicing pressures to 10,000 psi are obtainable.

Liquid Nitrogen Pumping System

The liquid nitrogen system for chilling the chamber shroud is also available for use in tests of cryogenic systems. Storage capacity of the system is 14,000 gallons of liquid nitrogen. The pumping system can deliver up to 160 gallons of LN₂ per minute at pressures to 110 psig.

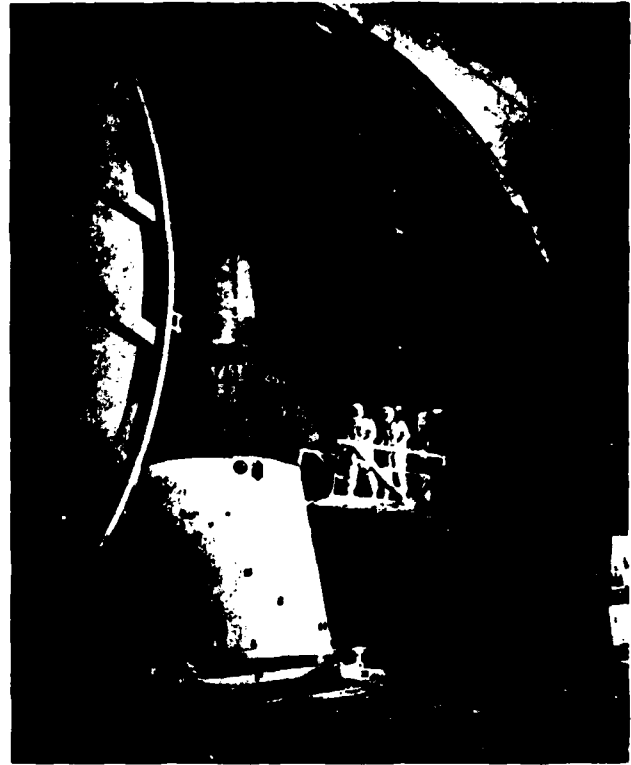

**MANNED TESTING OF GEMINI SPACECRAFT
(ASTRONAUTS ENTERING CAPSULE FROM
MANLOCK)**

MCDONNELL AIRCRAFT COMPANY

MCDONNELL DOUGLAS



ENGINEERING AND RESEARCH
 TECHNICAL FACILITY DESCRIPTION

30-Foot Space Simulation Chamber

The 30-foot chamber is used for thermal-vacuum testing of spacecraft and spacecraft subassemblies. The chamber is capable of being man-rated and of being certified in compliance with NASA safety criteria for manned altitude testing.

Operational Characteristics

Configuration

The chamber is a horizontal stainless-steel cylinder 30 feet in diameter and 35 feet long. It is closed on one end by a spherical head and on the opposite end by a full-opening door. Personnel locks are attached to one side of the chamber. These compartments are 11 feet in diameter. They are connected in series; the primary lock is 20 feet long and the secondary is 8 feet long.

Thermal Shroud

The chamber is lined with an aluminum shroud which can be maintained at temperatures from -300°F to +275°F by the circulation of liquid or gaseous nitrogen through passages in the shroud. The shroud, coated with a high emissivity epoxy paint, can dissipate 250 watts per square foot at -300°F on the door area and 125 watts per square foot on the remaining portions.

Vacuum Pumping System

The pumping for the chamber includes seven 35-inch fractionating oil diffusion pumps capable of operating at 52,000 liters per second per pump; two mechanical pumps, one capable of operating at 1,000 scfm and the other at 250 scfm; and a steam ejector capable of 3,300 scfm. This pumping system is capable of attaining a chamber pressure of 5×10^{-9} Torr in seven hours from atmospheric conditions.

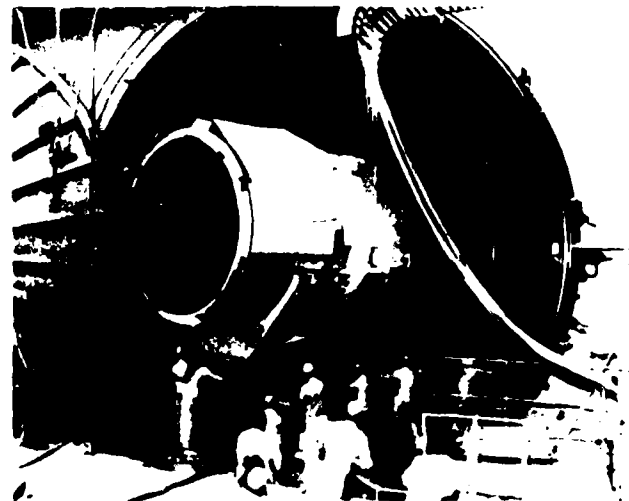

AIRLOCK/MULTIPLE DOCKING ADAPTER BEING MOVED INTO CHAMBER FOR SYSTEMS VERIFICATION TESTS

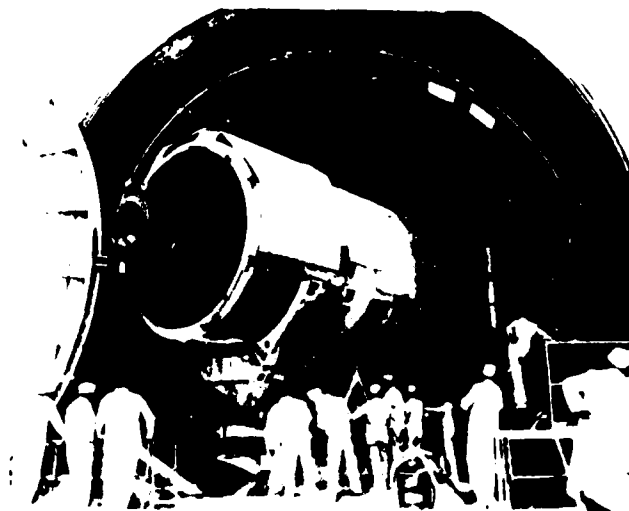

Man Rated

This facility has manned testing certification capability in accordance with the requirements of NASA Directive 8825.2. The dual compartment manlock serves to accommodate Rescue Observer Teams during manned tests. Rescue personnel are stationed in the primary lock at an intermediate altitude to facilitate emergency procedures in the event of an accident. The secondary lock is used to exchange rescue personnel without affecting the main test. The primary manlock is air-conditioned for the comfort of rescue observers during long

Pumping System Capability					
	Absolute Pressure (Torr)	Specimen Gas Load	Pump-Down Time (Hours)	Equivalent Altitude (Feet)	(Naut Miles)
Steam Ejector	87.0	100 lb/min	.16	50,000	8.2
and Mechanical Pumps	26.0	60 lb/min	.21	75,000	12.3
	8.3	25 lb/min	.26	100,000	16.4
Diffusion Pumps	2.0	0 lb/min	.36	135,000	22.2
	1×10^{-4}	17.1 Torr Liters/sec	3.0	325,000	53.5
	1×10^{-7}	8.5×10^{-3} Torr Liters/sec	7.0	540,000	89.0
	5×10^{-9}	zero	9.0	1,900,000	312.0

FACILITY LOCATION	DEPT NO 25b	BLDG NO 103
CITY St. Louis	STATE Mo	

MCDONNELL DOUGLAS -- HUNTINGTON BEACH, CA.
SPACE SIMULATION LABORATORY

SCHMATIC

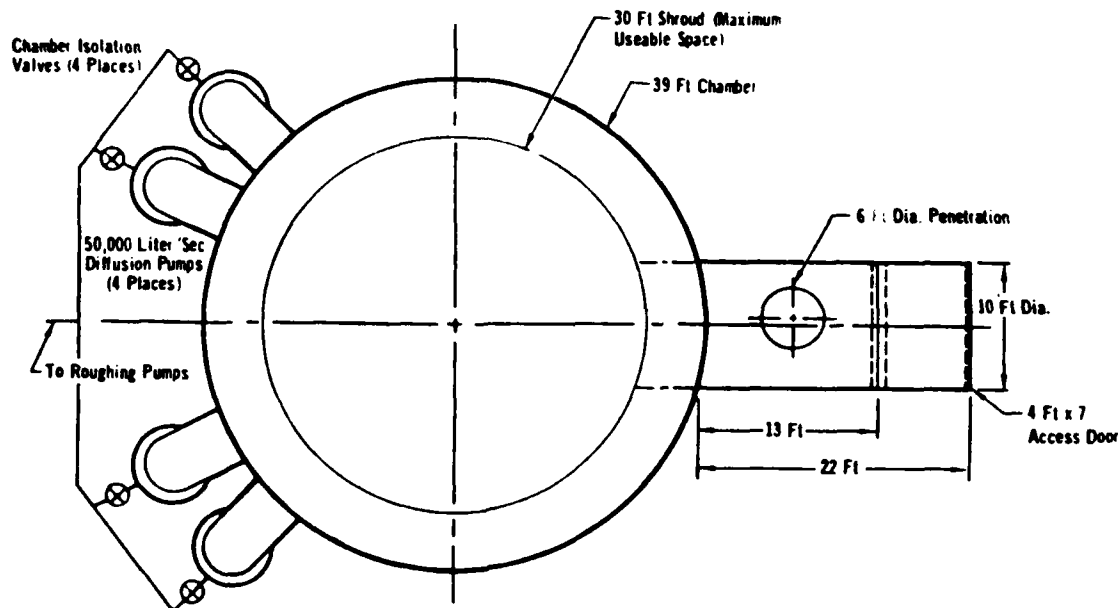

FACILITY PERFORMANCE DATA

Thirty-Nine-Foot-Diameter Space Simulator Pumping Curve

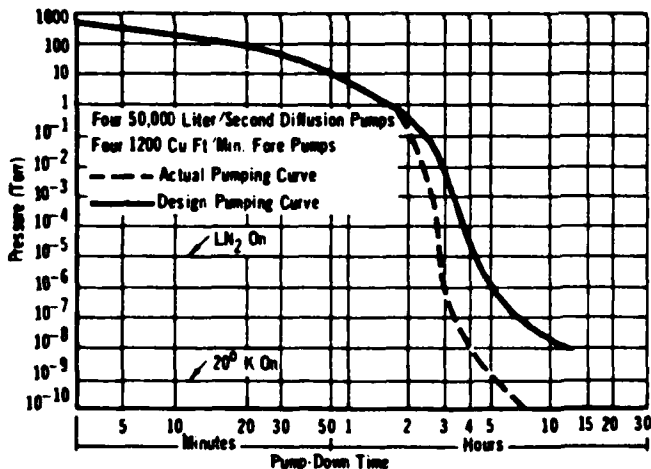

Facility Name: 39-Foot Space Simulator

Type of Environments Simulated*: 1

Type of Pump or Ejector**: 1, 2, & 3

Temperature Range (°C): Ambient and -195

Minimum Work Pressure (Torr): 1×10^{-9}

Man-Rated: Yes

Chamber Dimensions (ft): 39D Sphere

Maximum Specimen Dimensions (feet): 30 (in any dimension)

ADDITIONAL ENVIRONMENTAL CHAMBERS

Facility Name	Type of Environments Simulated	Type of Pump or Ejector**	Temp. Range (°C)	Rel. Hum. (%)	Alt. (ft)	Min. Work Pressure (Torr)	Man-Rated	Solar Sim.***	Chamber Dimen. (ft)	
									Dia.	l x w x h
Space Sta. Sim	2	1	Ambient	-	91K	-	Yes	No	12	40L
Prim. Airlock(a)	1	1, 2	Ambient	-	-	1×10^{-6}	Yes	4D/130	10	13L
Sec Airlock	2	1	Ambient	-	250K	-	Yes	-	10	7L
Space Simul.	1	1, 2	-195 to 135	-	-	1×10^{-6}	No	-	10	12L
Space Simul.	1	1, 3, 7, & 8	-195 to 253	-	-	1×10^{-10}	No	4D/130	8	8L
Plus 3 other space simulation chambers, two 5D x 6L (ft) and one 3D x 4L (ft).										

* 1 Space Simulations, 2 Altitude, 3 Salt Spray, 4 Dust, 5 Humidity, 6 Solar Simulation, 7 Thermal
 **Type of system used to evacuate chamber: 1 Roughing Pumps, 2 Oil-Diffusion, 3 Cryo-Pumping, 4 Steam Ejector, 5 Air Ejector, 6 Sputter-Ion, 7 Titanium Sublimation, 8 Sorption
 ***Beam size (ft) and intensity (watts/ft²) a: attached to 39-foot Space Simulator

(Reference 12)

BOEING KENT SPACE CENTER

SCHMATIC

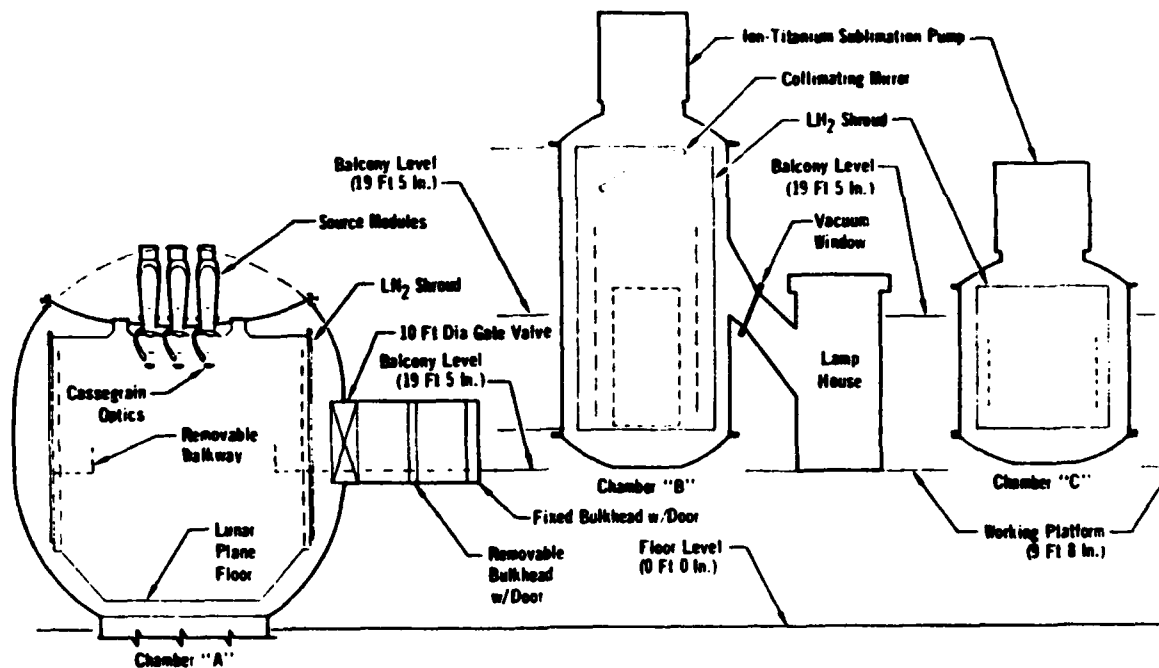

FACILITY PERFORMANCE DATA

Operating Envelope (Not Available)	Facility Name:	Chamber A
	Type of Environments Simulated*:	1,6
	Type of Pump or Ejector**:	1,3,6
	Temperature Range (°F):	Not Available
	Altitude (feet):	Not Available
	Minimum Work Pressure (Torr):	10 ⁻⁷
	Man-Rated:	No (Antichambers are constructed as manlocks if chamber becomes man rated)
	Chamber Dimension (feet):	39 dia x 50H

ADDITIONAL ENVIRONMENTAL CHAMBERS

Facility Name	Type of Environs Simulated*	Type of Pump or Ejector**	Temp. Range (°C)	Rel Hum. (%)	Alt. (ft)	Min. Work Pressure (Torr)	Man-Rated	Solar Sim.***	Chamber Dimen. (ft)	
									Dia.	l x w x h
Chamber B	1,2,6	1,3,6	N/A	N/A	N/A	10-11	No		10	20H
Chamber C	1,2	1,3,6	N/A	N/A	N/A	10-11	No	N/A	10	10H
Chamber 1	1,6	1,3,6				10-10	No	x-25L	5	5L
Chambers 2,3,4	1,6	1,3,6				10-10	No	x-25L	3	4L
Chambers 5,6	1,6	1,2,3				10-10	No	x-25L	2.5	2.5L
Chamber 9	1,6	1,3,6				10-9	No	x-25L	3	6L

* 1 Space Simulations, 2 Altitude 3 Salt Spray, 4 Dust, 5 Humidity, 6 Solar Simulation, 7 Thermal
 **Type of system used to evacuate chamber: 1 Roughing Pumps, 2 Oil-Diffusion, 3 Cryo-Pumping, 4 Steam Ejector, 5 Air Ejector, 6 Ion-Titanium Sublimation
 ***Beam size (ft) and intensity (watts/ft²)

(Reference 12)

JET PROPULSION LABORATORY ENVIRONMENTAL TEST FACILITY

The Jet Propulsion Laboratory maintains NASA-owned Environmental Test Facilities for its research programs. These facilities may be made available, with NASA approval, to any government agency and, under certain conditions, to private industry when their unique capabilities are required for precise thermal balance and design verification.

The 25-foot Space Simulator, built in 1961, has undergone modifications through the years to keep pace with expanding simulation requirements. In addition, a 10-foot Space Simulator was built in 1965 to further enhance the JPL ground test capabilities. Both of these large facilities are capable of producing high-quality space simulation for testing spacecraft under conditions of extreme cold, high vacuum, and intense, highly uniform, collimated solar radiation.

These facilities provide high-quality empirical verification of mission performance and have

supported many NASA orbital and planetary flight programs as well as military and commercial satellite and spacecraft programs, including support for programs of foreign governments. Typical test usage of the space simulator includes:

- Temperature distribution studies of thermal models
- Qualification tests of flight spacecraft prior to launch
- Spin-balance tests of flight spacecraft in a vacuum up to 60 rpm
- Vacuum coating of large optical components using filament or electron beam processes

A liquid nitrogen-cooled shroud is available as a radiative heat sink. Test periods of several weeks' duration (24 hours a day) are possible.

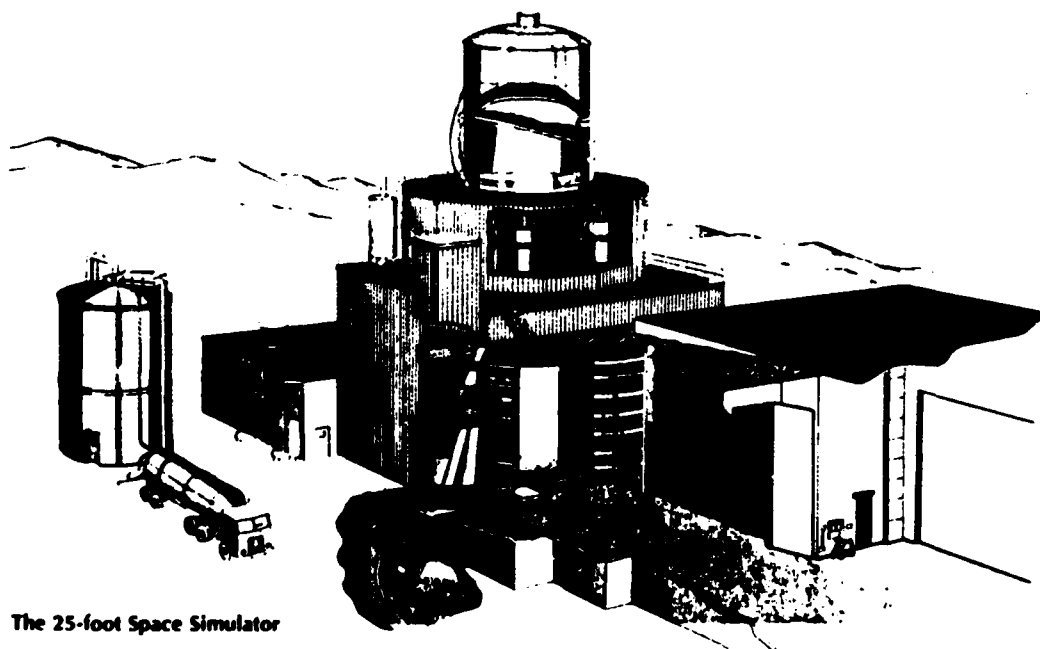

The 25-foot Space Simulator

Front Cover: Galileo in the Space Simulation Chamber

JET PROPULSION LABORATORY
ENVIRONMENTAL TEST FACILITY

The 25-foot Space Simulator chamber is a stainless-steel cylindrical vessel 27 feet in diameter and 85 feet high; a 15- by 25-foot side-opening access door is provided for test-item loading. A personnel door provides entry through the access door. The minimum operating pressure of the chamber is 5×10^{-6} torr. The walls and floor are lined with thermally opaque aluminum cryogenic shrouds controlled over a temperature range of -320° to $+200^{\circ}\text{F}$ (-196°C to $+93^{\circ}\text{C}$) by liquid or gaseous nitrogen. The off-axis solar simulation system consists of an array of 37 xenon 20- to 30-kilowatt compact arc lamps, an integrating lens unit, a penetration window, and a one-piece collimator. This provides a simulated solar beam that is reflected down into the test volume by the collimating mirror, which is temperature controlled with gaseous nitrogen through a range of -100° to $+200^{\circ}\text{F}$ (-73°C to $+93^{\circ}\text{C}$).

The test volume of the Simulator, 20 feet in diameter and 25 feet high, can be irradiated by a beam of simulated solar energy selected from

a variety of beam sizes and intensities shown in the accompanying table. The maximum beam diameter is 18.5 feet, which can provide intensities up to 2.7 solar constants. With a smaller collimating mirror and different integrating lens unit, a 9-foot diameter beam with intensities up to 12 solar constants can be provided. The spectrum is that of xenon arc lamps, as modified by the simulator optics. The uniformity of these beams is ± 5 percent as measured by a 0.25-inch diameter PIN diode detector. The collimation angle varies from ± 1 degree to ± 2 degrees as a function of beam selection. A water-cooled douser is provided to simulate eclipse of the sun.

The simulated space environment can be established in about 75 minutes. Test conditions can be terminated and access provided to the test item in about 2.5 hours.

A 1000-square-foot clean room facility is available for test article assembly and system test prior to environmental testing. An air lock separates the class 10,000 clean room from the Simulator.

CURRENT SOLAR PERFORMANCE CAPABILITIES

Mixer and Beam Diameter (Feet)	Lamps Available	Maximum Operating Solar Intensity (SC) ^a All Lamps at 25 kW ^b	Collimator Size (Feet)
SSB-18.5	37	2.7	23
SSB-15.5	37	4.1	23
SSB-15	37	4.3	23
SSB-8	7	2.6	23
SSC-11	37	8.0	15
SSC-9	37	12.0	15

^a1 Solar Constant = 126 W/ft².

^bOperation at these solar intensities may limit test duration.

GENERAL DYNAMICS CORPORATION -- FORT WORTH, TX
HIGH ALTITUDE LABORATORY

SCHMATIC

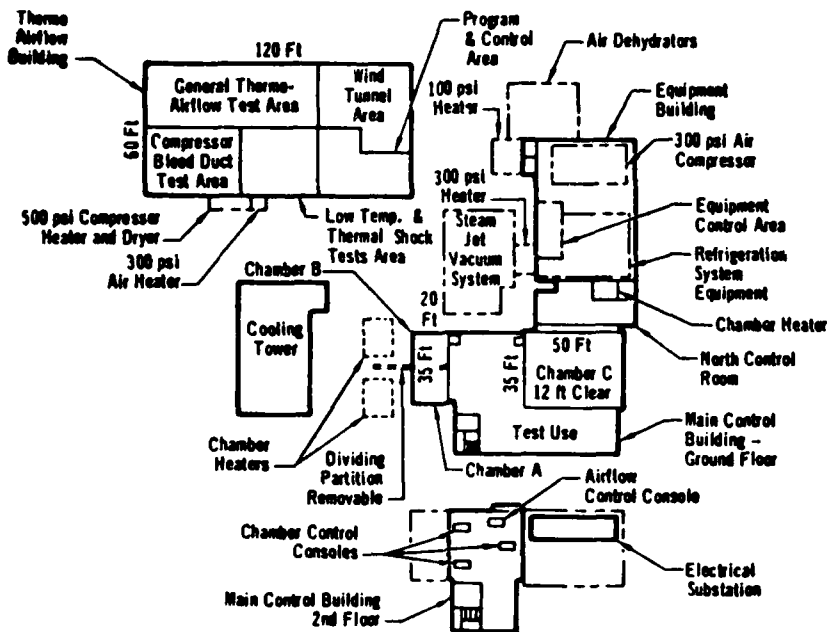

FACILITY PERFORMANCE DATA

Facility Name: High Altitude Laboratory

Type of Environments Simulated*: 2,5,7,8
 Type of Pump or Ejector**: 4
 Temperature Range (C°): -73 to 205
 Altitude (feet): 120,000
 Minimum Work Pressure (Torr): 3.3
 Man-Rated: No
 Chamber Dimensions (ft): Two - 34 x 50 x 14
 Three - 35 x 20 x 14

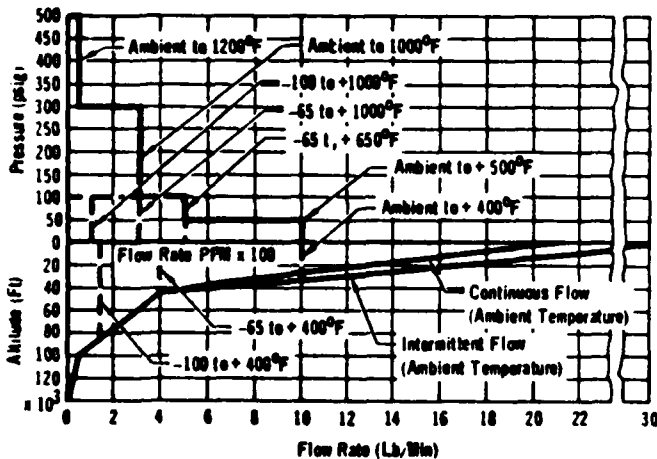

ADDITIONAL ENVIRONMENTAL CHAMBERS

Facility Name	Type of Environ Simulated*	Type of Pump or Ejector**	Temp. Range (C°)	Rel Hum. (%)	Alt. (ft)	Min. Work Pressure (Torr)	Man-Rated	Solar Sim.***	Chamber Dimen. (ft)	
									Dia.	l x w x h
Zaleski	2,7,8	6	-73 to 82	Amb.	80K	21.1	No	No	7x7x7	
Tenney (2)	2,7,8	6	-73 to 260	Amb.	120K	3.3	No	No	3x3x4	
Tenney	5	N/A	1 to 93	Amb.	Atmos	N/A	No	No	1.5x1.5x4	
Amer. Inst. Co.	9	N/A	Amb. to 93	Amb.	Atmos	N/A	No	No	4x2x1.5	
Blue M	5	N/A	-18 to 93	Amb.	Atmos	N/A	No	No	4x4x4	
Amer. Inst. (2)	7	N/A	Amb. to 260	Amb.	Atmos	N/A	No	No	2x2x3	

* 1 Space Simulations, 2 Altitude, 3 Salt Spray, 4 Dust, 5 Humidity, 6 Solar Simulation, 7 Thermal
 8 Low Temperature, 9 Fungus
 **Type of system used to evacuate chamber: 1 Roughing Pumps, 2 OIL-Diffusion, 3 Cryo-Pumping,
 4 Steam Ejector, 5 Air Ejector, 6 Mechanical Pumps
 ***Beam size (ft) and intensity (watts/ft²)

(Reference 12)

GRUMMAN AEROSPACE

SCHEMATIC

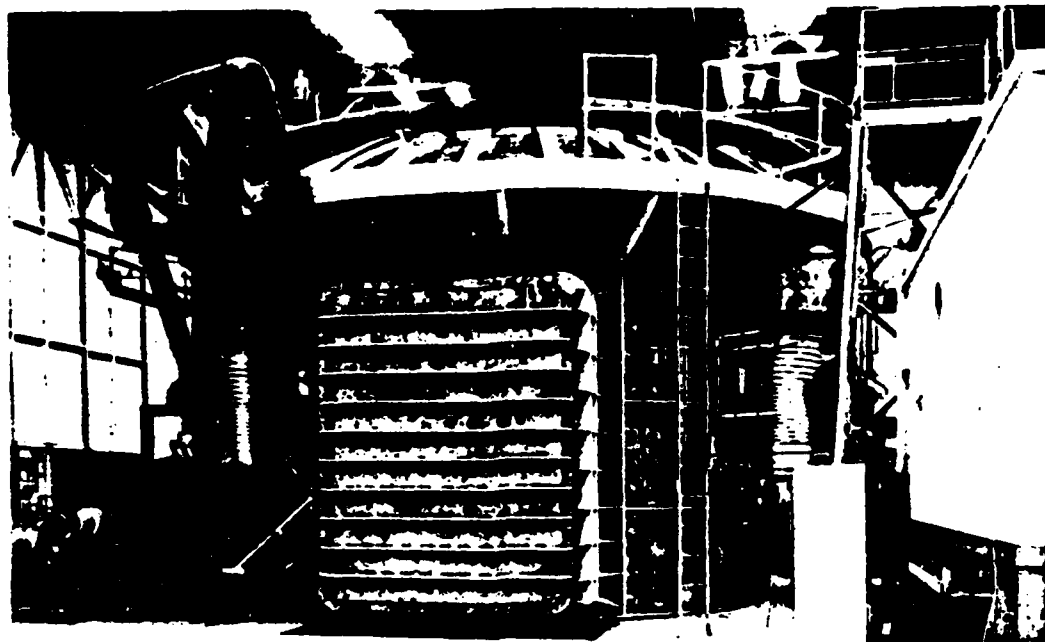

FACILITY PERFORMANCE DATA

Typical Pumpdown (Clean, Dry and Empty)

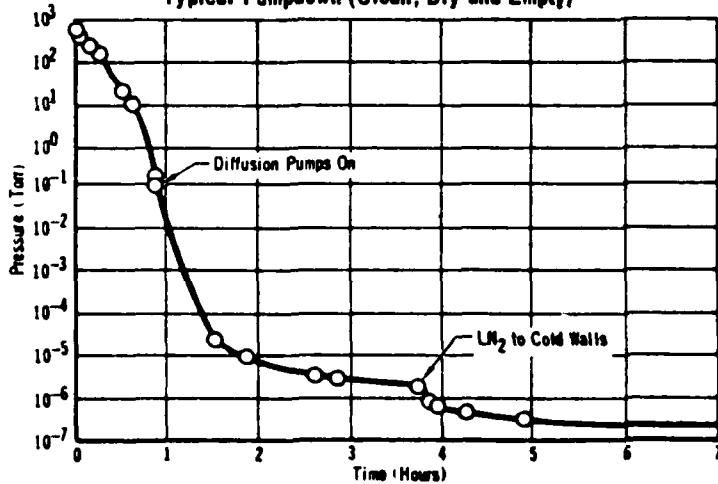

Facility Name: 19 x 26-Foot Vacuum Chamber

Type of Environments Simulated*: 1, 2

Type of Pump or Ejector**: 1, 2

Temperature Range (°C): -206 to +176

Altitude (feet): -

Minimum Work Pressure (Torr): 1 x 10⁻⁷

Chamber Internal Dimensions (feet): 15W x 20H

Maximum Specimen Size (ft): Not Available

ADDITIONAL ENVIRONMENTAL CHAMBERS

Facility Name	Type of Environs Simulated*	Type of Pump or Ejector**	Temp. Range (°C)	Rel Hum. (%)	Alt. (ft)	Min. Work Pressure (Torr)	Man-Rated	Solar Sim.***	Chamber Dimen. (ft)	
									Dia.	l x w x h
22-Ft Sphere	1, 6	1, 5	Ambient	N/A		1.5	No	Yes	18	
4-Ft Chamber	1, 2	1, 2	-206 to 149	N/A		10 ⁻⁶	No	No	3.58	x 8L
7-Ft Chamber	1, 2	1, 2	-206 to 149	N/A		5 x 10 ⁻⁹	No	No	5	x 6L
8x34-Ft Chmbr	1, 2, 6	1, 2	-195.5	N/A		10 ⁻⁷	No	Yes	8	x 34
4-Ft Chamber	1, 2, 5	1, 2	-17.7 to 71	to 95%		10 ⁻⁵	No	No	4	x 4L

* 1 Space Simulations, 2 Altitude, 3 Salt Spray, 4 Dust, 5 Humidity, 6 Solar Simulation, 7 Thermal
 **Type of system used to evacuate chamber: 1 Roughing Pumps, 2 Oil-Diffusion, 3 Cryo-Pumping, 4 Steam Ejector, 5 Air Ejector
 ***Beam size (ft) and intensity (watts/ft²)

(Reference 12)