

AD-A175 379

12



AFWAL-TP-86-3071  
Volume I

V/STOL CONCEPTS AND DEVELOPED AIRCRAFT  
VOL I - A Historical Report (1940 - 1986)

B. Lindenbaum  
Universal Energy Systems

November 1986

Final Report for Period 3 September 1978 - 26 June 1986

Approved for public release; distribution is unlimited.

DTIC FILE COPY

DTIC  
S DEC 29 1986 D  
E

FLIGHT DYNAMICS LABORATORY  
AIR FORCE WRIGHT AERONAUTICAL LABORATORIES  
AIR FORCE SYSTEMS COMMAND  
WRIGHT-PATTERSON AIR FORCE BASE, OHIO 45433-6502

UNCLASSIFIED

SECURITY CLASSIFICATION OF THIS PAGE

REPORT DOCUMENTATION PAGE

1a. REPORT SECURITY CLASSIFICATION <b>UNCLASSIFIED</b>		1b. RESTRICTIVE MARKINGS	
2a. SECURITY CLASSIFICATION AUTHORITY		3. DISTRIBUTION/AVAILABILITY OF REPORT Approved for public release; distribution is unlimited.	
2b. DECLASSIFICATION/DOWNGRADING SCHEDULE			
4. PERFORMING ORGANIZATION REPORT NUMBER(S)		5. MONITORING ORGANIZATION REPORT NUMBER(S) AFWAL-TR-86-3071, Vol I	
6a. NAME OF PERFORMING ORGANIZATION Universal Energy Systems	6b. OFFICE SYMBOL (If applicable)	7a. NAME OF MONITORING ORGANIZATION Flight Dynamics Laboratory	
6c. ADDRESS (City, State and ZIP Code) 4416 Dayton-Xenia Rd Dayton OH 45432		7b. ADDRESS (City, State and ZIP Code) AFWAL/FIA Wright-Patterson AFB OH 45433	
8a. NAME OF FUNDING/SPONSORING ORGANIZATION	8b. OFFICE SYMBOL (If applicable) AFWAL/FIA	9. PROCUREMENT INSTRUMENT IDENTIFICATION NUMBER F33615-83-C-3000	
8c. ADDRESS (City, State and ZIP Code) AFWAL/FIA Wright-Patterson AFB OH 45433		10. SOURCE OF FUNDING NOS.	
11. TITLE (Include Security Classification) (U) V/STOL Concepts & Developed Aircraft, A Historic Report, Vol I, (1940-1986)		PROGRAM ELEMENT NO. 62201F	PROJECT NO. 3038
12. PERSONAL AUTHOR(S) Bernard Lindenbaum		TASK NO. 00	WORK UNIT NO. 01
13a. TYPE OF REPORT Final	13b. TIME COVERED FROM 78-10-03 TO 86-06-26	14. DATE OF REPORT (Yr., Mo., Day) 860626	15. PAGE COUNT 454
16. SUPPLEMENTARY NOTATION This report is the final product of joint effort with the U.S. Navy, begun in Oct 1978, under contract N00019-78-C-0552 with the University of Dayton.			
17. COSATI CODES		18. SUBJECT TERMS (Continue on reverse if necessary and identify by block number)	
FIELD	GROUP	V/STOL Aircraft, VTOL Aircraft, VATOL Rocket Belts, Platforms <i>cont'd p. 11</i>	
01.2	G103		
19. ABSTRACT (Continue on reverse if necessary and identify by block number) This report is the first volume of a comprehensive historical and technical review of VTOL and V/STOL concepts both aircraft built and important design studies accomplished since the start of U.S. Government sponsored effort in the late 1940's. This volume contains an introductory review of V/STOL aircraft concepts and the rationale behind them. The concepts are categorized by propulsion system. This volume contains definitive information and technical reviews of the rocket belt, turbojet/turbofan platform type (wingless) vehicles, and turbojet/turbofan vertical attitude takeoff and landing aircraft. Contained in this volume are 454 pages containing 211 figures and 47 tables.			
20. DISTRIBUTION/AVAILABILITY OF ABSTRACT UNCLASSIFIED/UNLIMITED <input checked="" type="checkbox"/> SAME AS REPORT <input type="checkbox"/> DTIC USERS <input type="checkbox"/>		21. ABSTRACT SECURITY CLASSIFICATION UNCLASSIFIED	
23. NAME OF RESPONSIBLE INDIVIDUAL DANIEL B. LOWRY		22a. TELEPHONE NUMBER (Include Area Code) 513-255-2377	22b. OFFICE SYMBOL AFWAL/FIA

FOREWORD

△  
The purpose of this document is to present a comprehensive, in-depth review of the serious efforts made in the development of VTOL and V/STOL concepts and aircraft other than the helicopter. The time period covered is from the beginning of organized government-sponsored activity in the late 1940's through the present, during which a very large study and development activity has taken place. Conventional helicopters are not included because their development history is a sizeable subject in itself and one which is already well-documented. Included ~~however~~ are V/STOL aircraft which do use rotors but are aimed at providing cruise speeds and aerodynamic efficiencies similar to those of conventional airplanes. Although not aircraft in the conventional sense, wingless VTOL vehicles which use direct thrust (rocket or turbojet/turbofan) for lift in all flight modes also are included since such machines do have a close relationship to some of the more commonly accepted forms of VTOL aircraft. → *to p 6*

Preparation of this document was sponsored jointly by the U.S. Air Force and Navy to provide a ready reference and guide in the continuing and future development of VTOL and V/STOL vehicles. The document is arranged to permit easy incorporation of new developments and, also, the making of revisions when new material becomes available relating to concepts and aircraft already covered. A decimal numbering system is used to identify the various sections and subsections to allow easy revision and expansion.

Categorization and grouping of the various vehicles and concepts is based on the propulsion system with "disc loading", progressing from high to low, being used to establish the order of presentation. This led to four major propulsion categories: rocket, turbojet/turbofan, propeller and rotor. These, plus the "Introduction and Background," make up the five sections of the document which is to be presented in a series of volumes.

To date only the first volume has been completed and published. It contains, in addition to the Introduction and Background section, sections covering: Rocket Based Vehicles, Turbojet/Turbofan-Powered Vehicles of the wingless type, and Turbojet/Turbofan-Powered Aircraft of the Vertical Attitude Take Off and Landing type. Other volumes, yet to be written, are intended to cover all of the other forms of turbojet/turbofan V/STOL aircraft, aircraft which use propellers, and those which use helicopter type rotors.

The various VTOL and V/STOL efforts of interest are collected into the pertinent sections and reviewed to provide such information as:

Origin of the concept and the reason for interest in it.  
Merits and questions regarding the concept.  
Company-sponsored work done.  
Objectives of the work.  
Government interest, funding and contracts.  
Progress made, successes achieved.  
Failures, problems revealed and solutions.  
Outcome of the programs and reasons for termination.  
Chronology of the programs significant events.  
Relationship to other VTOL and V/STOL efforts.  
Contributions to advancement of the state-of-the-art.  
Concluding observations.

Preparation of the document required examination and review of a large amount of information obtained from private individuals, government files, public documents and companies. Cooperation from companies and government agencies has been excellent; without their help, much material would not have been available. Proprietary material, without specific permission to use, and classified information have not been included.

Unfortunately, it was not possible to maintain a uniformly good depth of coverage of all the significant VTOL and V/STOL efforts because of the variability in the amount and nature of the material available on each subject. Included in each case is all the important available information essential to the review.

The following have provided information used in this first volume.

Aerospatiale  
Bell Aerosystems Company  
Flight Dynamics Research Corporation  
Garrett-AiResearch Manufacturing Company of California  
General Dynamics Corporation  
Grumman Aerospace Corporation  
Ling-Temco-Vought Aerospace  
Lockheed Corporation  
Northrop Corporation  
Piasecki Aircraft Corporation  
Societe Nationale d'Etude et de Construction de Moteurs  
d'Aviation (SNECMA)  
Teledyne Ryan Aeronautical  
Thiokol Corporation  
Vereingte Flugtechnische Werke-Fokker, GMBH  
Williams International Corporation  
U.S. Army Infantry School, Ft. Benning  
U.S. Army Tank Automotive Research and Development Command  
Headquarters, U.S. Marine Corps.  
U.S. Navy David Taylor Naval Ship Research and  
Development Center  
U.S. Navy, Naval Air Systems Command  
U.S. Navy Naval Weapon Center

TABLE OF CONTENTS

<u>SECTION</u>	<u>TITLE</u>	<u>PAGE</u>
	FOREWORD . . . . .	ii
	TABLE OF CONTENTS . . . . .	iv
	LIST OF FIGURES . . . . .	vii
	LIST OF TABLES . . . . .	xx
1	INTRODUCTION AND BACKGROUND . . . . .	1-1
	REFERENCES TO SECTION 1 . . . . .	1-29
2	ROCKET BASED VTOL VEHICLES . . . . .	2-1
	2.1 INTRODUCTION . . . . .	2-1
	2.2 DIRECT (UNAugMENTED) ROCKET THRUST VEHICLES . . . . .	2-11
	2.2.1 U.S. Army Small Rocket Lift Device (SRLD) Program (1957-1961) . . . . .	2-11
	2.2.2 Bell Aerosystems "Rocket Belt" and Rocket "Pogostick" Developments (1957-1962) . . . . .	2-12
	2.2.3 Aerojet-General Corporation Small Rocket Lift Device (SRLD) Study for the U.S. Army (TRECOM) (1958-1959) . . . . .	2-29
	2.2.4 Thiokol-Reaction Motors Division "Jump Belt" . . . . .	2-33
	2.3 AUGMENTED ROCKET THRUST VEHICLES . . . . .	2-46
	2.3.1 Introductory Comments . . . . .	2-46
	2.3.2 Sud-Aviation Augmented Thrust Rocket Vehicle, "Ludion" (1964-1968) . . . . .	2-53
	REFERENCES TO SECTION 2 . . . . .	2-62
3	VTOL AND V/STOL AIRCRAFT WITH TURBOJET/ TURBOFAN PROPULSION . . . . .	3-1
	3.1 INTRODUCTION . . . . .	3-1
	REFERENCES TO SECTION 3.1 . . . . .	3-13

TABLE OF CONTENTS (continued)

<u>SECTION</u>	<u>TITLE</u>	<u>PAGE</u>
3.2	TURBOJET/TURBOFAN POWERED WINGLESS VEHICLES . . . . .	3-14
3.2.1	Introductory Comments . . . . .	3-14
3.2.2	Bell Aerosystems Company Turbojet Individual Mobility Devices (1966-1969) . . . . .	3-17
3.2.3	U.S. Marine Corps Small Tactical Aerial Mobility Platform (STAMP) and U.S. Army Individual Lift Device (ILD) Program . . . . .	3-31
3.2.3.1	Introductory Comments . . . . .	3-31
3.2.3.1.1	Marine Corps STAMP Program . . . . .	3-31
3.2.3.1.2	U.S. Army Individual Lift Device (ILD) Program . . . . .	3-39
3.2.3.2	Williams International WASP I (Marine Corps STAMP) and WASP II (Army ILD) . . . . .	3-41
3.2.3.2.1	WASP I (Marine Corps STAMP) (1971-1972) . . . . .	3-43
3.2.3.2.2	WASP II (Army ILD) (1978-1983) . . . . .	3-52
3.2.3.3	Garrett-AiResearch Manufacturing Company STAMP (1972-1974) . . . . .	3-70
3.2.3.4	Naval Weapons Center Ejector Augmented STAMP and Alperin Jet-Diffuser Ejector Propulsion System (1974-1976) . . . . .	3-91
3.2.3.5	Piasecki Aircraft Company Preliminary Design Study (1973) . . . . .	3-101
	REFERENCES TO SECTION 3.2 . . . . .	3-115
3.3	TURBOJET/TURBOFAN L/C-VERTICAL ATTITUDE TAKE-OFF AND LANDING (VATOL) AIRCRAFT . . . . .	3-117
3.3.1	Introduction . . . . .	3-117

TABLE OF CONTENTS (continued)

<u>SECTION</u>	<u>TITLE</u>	<u>PAGE</u>
3.3.2	Ryan Aeronautical Company X-13 (Model 69, "Vertijet") (1947-1957) . . . . .	3-131
	REFERENCES TO SECTION 3.3.2 . . . . .	3-166
3.3.3	SNECMA C.450 Coleopter (1951-1959) . . . . .	3-167
	REFERENCES TO SECTION 3.3.3 . . . . .	3-222
3.3.4	U.S. Navy David Taylor Naval Ship Research and Development Center (DTNSRDC) VATOL Remotely Piloted Vehicle, XBQM-108A (1973-1977) . . . . .	3-223
	REFERENCES TO SECTION 3.3.4 . . . . .	3-244
3.3.5	Vertical Attitude Take-Off and Landing (VATOL) Airplane Design Studies (1954-1959) . . . . .	3-245
3.3.5.1	Introductory Comments . . . . .	3-245
3.3.5.2	Temco Design Study (1953-1954) . . . . .	3-251
3.3.5.3	Convair Design Study (1953-1954) . . . . .	3-270
3.3.5.4	Lockheed Design Study (1954-1955) . . . . .	3-282
3.3.5.5	Ryan Aeronautical VATOL Aircraft Designs (1954-1957) . . . . .	3-314
	REFERENCES TO SECTION 3.3.5 . . . . .	3-340



Accession For	
NTIS GRA&I	<input checked="" type="checkbox"/>
DTIC TAB	<input type="checkbox"/>
Unannounced	<input type="checkbox"/>
Justification	
by _____	
Distribution/	
Availability Codes	
Avail and/or	
Dist	Special
A-1	

LIST OF FIGURES

<u>FIGURE NO.</u>	<u>DESCRIPTION</u>	<u>PAGE</u>
1.1	Leonardo da Vinci's Vertical Lift Machine (Helicopter), 1490 . . . . .	1-2
1.2	Sir George Cayley's Combined Helicopter - Airplane Concept, 1809 . . . . .	1-3
1.3	Hall-Matthews Fan-In-Wing Airplane Concept, 1921 . . . . .	1-3
1.4	Stoppable Rotor (Rotor-Wing) Airplane Concept by R. P. Pescara, 1922 . . . . .	1-4
1.5	W. Margoulis Tilting-Propeller Airplane Concept, 1922 . . . . .	1-5
1.6	Ramon Oriol's Vertical Attitude Take-Off and Landing Airplane Concept, 1924 . . . . .	1-6
1.7	Jean de Chappedlaine's Vectored Thrust Concept, 1926 . . . . .	1-7
1.8	J. C. Johnson Stoppable Rotor STOL Airplane, Flown in 1929 . . . . .	1-7
1.9	Gerard P. Herrick HV-2A Stoppable Rotor (Rotor-Wing) Autogyro-Airplane, Flown in 1937 . . . . .	1-9
1.10	General Electric "Heliplane" Concept, Helicopter to Airplane Transition . . . . .	1-10
1.11	Chronology of Developed Experimental V/STOL Airplanes . . . . .	1-11
1.12	Major Categories of VTOL and V/STOL Vehicles - Rockets and Turbojet/Turbofan Approaches . . . . .	1-15
1.13	Major Categories of VTOL & V/STOL Vehicles - Propeller and Rotor Approaches . . . . .	1-16
1.14	Power Required to Produce Static Thrust for Different Propulsion Systems . . . . .	1-20
1.15	Static Thrust Specific Fuel Consumption vs. Disc Loading for Different Propulsion Systems . . . . .	1-21

LIST OF FIGURES (continued)

<u>FIGURE NO.</u>	<u>DESCRIPTION</u>	<u>PAGE</u>
1.16	Thrust Versus Mach Number for Several Bypass Ratios . . . . .	1-23
1.17	Propulsive Efficiency Envelopes of Propellers . . . . .	1-24
1.18	Downwash Velocity as a Function of Disc Loading . . . . .	1-26
1.19	Effect of Disc Loading on Perceived Noise Levels . . . . .	1-26
1.20	Turboprop Noise Levels as a Function of Propeller-Tip Mach Number and the Number of Blades . . . . .	1-27
1.21	Exhaust Noise from Jet Engines as a Function of Jet Exhaust Velocity . . . . .	1-27
2.1.1	Lunar Module . . . . .	2-2
2.1.2	Categories of Rocket Powered Vehicles . . . . .	2-3
2.1.3	Bell Aerosystems Lunar Flight Vehicle (LFV) . . . . .	2-4
2.1.4	Bell Aerosystems Manned Flying System (MFS) . . . . .	2-4
2.1.5	German World War II Bachem BA-349B "Natter" VTO Interceptor . . . . .	2-5
2.1.6	Bachem BA-349B Rocket Airplane Mounted on VTO Apparatus . . . . .	2-7
2.2.2.1	Important Elements of the Bell Aerosystems Rocket Belt . . . . .	2-13
2.2.2.2	Bell Aerosystems Nitrogen-Powered Rocket Lift Device Tethered Flight Test Rig . . . . .	2-15
2.2.2.3	Bell Aerosystems One Man Rocket Powered Pogostick . . . . .	2-16
2.2.2.4	Bell Aerosystems Two Man Rocket Powered Pogostick . . . . .	2-16

LIST OF FIGURES (continued)

<u>FIGURE NO.</u>	<u>DESCRIPTION</u>	<u>PAGE</u>
2.2.2.5	Bell One-Man Rocket Powered Flying Seat . . . . .	2-17
2.2.2.6	NASA Kinesthetically-Controlled Jet Platform in Hover Flight . . . . .	2-20
2.2.2.7	Bell Aerosystems Methods of Vectoring Rocket Thrust . . . . .	2-20
2.2.2.8	Bell Aerosystems SRLD Feasibility Demonstrator for U.S. Army . . . . .	2-23
2.2.2.9	Final Configuration of the Bell Aerosystems Rocket Belt, in Flight . . . . .	2-25
2.2.2.10	Flight with Bell Aerosystems Rocket Belt, Rear View . . . . .	2-26
2.2.2.11	Bell Aerosystems Analog-Type Rocket Belt Pilot Trainer . . . . .	2-27
2.2.4.1	Improvement in Capability with Jump Belt . . . . .	2-34
2.2.4.2	Jump Belt Concept Patented by Alexander H. Bohr of Thiokol, Rocket Motor Division . . . . .	2-36
2.2.4.3	Thiokol RMD Proposed Production Solid Propellant Jump Belt . . . . .	2-37
2.2.4.4	Thiokol RMD Mock-Up of Solid Propellant Jump Belt . . . . .	2-38
2.2.4.5	Three Views of Thiokol RMD Hydrogen Peroxide Jump Belt Configuration . . . . .	2-39
2.2.4.6	Thiokol RMD Small Rocket Lift Device (SRLD) Configuration Using Hydrogen Peroxide . . . . .	2-42
2.2.4.7	Jumping with Thiokol RMD Nitrogen Gas Jump Belt . . . . .	2-43
2.2.4.8	Thiokol RMD Low Capacity (200 lb/sec) Hydrogen Peroxide Jump Belt . . . . .	2-44
2.3.1.1	Aerospace General Rocket Powered Helicopter . . . . .	2-47

LIST OF FIGURES (continued)

<u>FIGURE NO.</u>	<u>DESCRIPTION</u>	<u>PAGE</u>
2.3.1.2	Bell Aerosystems Rocket Belt with Shrouded Fan Thrust Augmentation . . . . .	2-50
2.3.1.3	Martin Baltimore Model M380-2 Tilt Wing Plus Lift-Fan V/STOL Airplane Design . . . . .	2-51
2.3.1.4	Inboard Profile of Martin Baltimore Model M380-2 V/STOL Aircraft . . . . .	2-52
2.3.2.1	Sud-Aviation Original Strap-On Augmented Thrust Rocket Belt Concept . . . . .	2-54
2.3.2.2	Sud-Aviation Strap-On Augmented Thrust Rocket Belt with Shock Absorbing Landing Device . . . . .	2-54
2.3.2.3	Sud-Aviation "Ludion" Individual Lift Device . . . . .	2-56
2.3.2.4	Sud-Aviation Ludion in Tethered Flight . . . . .	2-58
2.3.2.5	Sud-Aviation Ludion in Free Flight . . . . .	2-58
3.1.1	Categories of Turbojet/Turbofan Propelled VTOL and V/STOL Aircraft . . . . .	3-2
3.1.2	Thrust Requirements of a VTOL Fighter . . . . .	3-3
3.1.3	Representative Propulsion Arrangements for VTOL and V/STOL Aircraft . . . . .	3-6
3.2.1.1	Bell Aerosystems Lunar Landing Research Vehicle (LLRV) . . . . .	3-15
3.2.1.2	Bristol Siddeley "Flying Pig" . . . . .	3-15
3.2.1.3	Hiller Helicopters Proposed Turbojet Lift Wingless Vehicle . . . . .	3-16
3.2.2.1	Jet Belt Patent (No. 3,243,144) Issued to John K. Hulbert . . . . .	3-18
3.2.2.2	Bell Aerosystems Jet Belt System in Flight . . . . .	3-19
3.2.2.3	Bell Aerosystems Jet Flying Belt . . . . .	3-22
3.2.2.4	Williams Research WR-19 Turbofan Engine . . . . .	3-25

LIST OF FIGURES (continued)

<u>FIGURE NO.</u>	<u>DESCRIPTION</u>	<u>PAGE</u>
3.2.2.5	Bell Aerosystems' Jet Lift Individual Mobility System Platform Type Arrangements . . . . .	3-27
3.2.2.6	Bell Aerosystems Wingless Twin Turbofan Engine Concept . . . . .	3-28
3.2.3.2.1.1	STAMP Vehicle as Originally Visualized by Williams Research . . . . .	3-44
3.2.3.2.1.2	Williams Research STAMP Vehicle with Tether Line Attached . . . . .	3-45
3.2.3.2.1.3	Williams Research STAMP Vehicle Side View . . . . .	3-46
3.2.3.2.1.4	Williams Research STAMP Vehicle in Flight, Safety Tether Line Unloaded . . . . .	3-47
3.2.3.2.1.5	Williams Research STAMP Vehicle, Rear View - Identification of Key Elements in Control System . . . . .	3-49
3.2.3.2.1.6	Williams Research STAMP Vehicle, Side View - Identification of Key Elements in Control System . . . . .	3-50
3.2.3.2.2.1	Williams International WASP II in Flight . . . . .	3-53
3.2.3.2.2.2	Williams International WASP II on Ground Handling Dolly . . . . .	3-59
3.2.3.2.2.3	Three-View Drawing Williams WASP II . . . . .	3-60
3.2.3.2.2.4	Main Components of Williams International WASP II . . . . .	3-61
3.2.3.2.2.5	Williams WR19-7 Internal Engine Details and Air Flows . . . . .	3-64
3.2.3.2.2.6	Williams International WASP II Theoretical Pitch Angle with Speed . . . . .	3-66
3.2.3.3.1	STAMP Vehicle as Visualized by AiResearch . . . . .	3-71

LIST OF FIGURES (continued)

<u>FIGURE NO.</u>	<u>DESCRIPTION</u>	<u>PAGE</u>
3.2.3.3.2	AiResearch STAMP Feasibility Demonstrator Vehicle, Side View . . . . .	3-72
3.2.3.3.3	AiResearch STAMP Feasibility Demonstrator Vehicle, Front View . . . . .	3-73
3.2.3.3.4	AiResearch Feasibility Demonstrator STAMP Vehicle Rear View . . . . .	3-74
3.2.3.3.5	Cockpit of Garrett AiResearch STAMP Feasibility Demonstrator Vehicle . . . . .	3-75
3.2.3.3.6	AiResearch STAMP Feasibility Demonstrator Vehicle in Tethered Flight . . . . .	3-76
3.2.3.3.7	Inboard Profile AiResearch STAMP Feasibility Demonstrator . . . . .	3-78
3.2.3.3.8	Airflow Diagram - AiResearch STAMP Feasibility Demonstrator . . . . .	3-79
3.2.3.3.9	Schematic View of Structural Arrangement of AiResearch Feasibility Demonstrator . . . . .	3-83
3.2.3.3.10	Control System - AiResearch STAMP Feasibility Demonstrator . . . . .	3-85
3.2.3.3.11	Method of Obtaining Roll Control - AiResearch STAMP Feasibility Demonstrator . . . . .	3-86
3.2.3.4.1	J. Bertin (France) Concept of a Small Lift Device . . . . .	3-92
3.2.3.4.2	Naval Weapons Center Twin ETA (Twin Chamber) STAMP Vehicle Concept . . . . .	3-93
3.2.3.4.3	Naval Weapons Center Twin ETA (Single Chamber) STAMP Vehicle Concept . . . . .	3-94
3.2.3.4.4	Configuration Comparison-- Coanda/Jet Diffuser Ejector and Typical High Performance Ejector . . . . .	3-96
3.2.3.4.5	Alperin Jet Diffuser Ejector - In Cross Section . . . . .	3-97

LIST OF FIGURES (continued)

<u>FIGURE NO.</u>	<u>DESCRIPTION</u>	<u>PAGE</u>
3.2.3.4.6	Elements of Alperin Jet Diffuser Ejector . . . . .	3-97
3.2.3.5.1	Piasecki Aircraft Model 159B STAMP Design, Bottom Rear View . . . . .	3-105
3.2.3.5.2	Piasecki Aircraft Model 159B Design, Top Rear View . . . . .	3-106
3.2.3.5.3	Piasecki Aircraft Model 159B Design with Two RC Engines - General Arrangement Drawing . . . . .	3-107
3.2.3.5.4	Piasecki Aircraft Model 159B Design - Structural Arrangement . . . . .	3-109
3.3.1.1	Ryan Aeronautical Vertical Take-Off and Landing Apparatus . . . . .	3-119
3.3.1.2	Boeing Sea Control Fighter Shipboard Handling . . . . .	3-120
3.3.1.3	Vought VATOL Airplane with Tricycle Landing Gear and Prong for Platform Engagement . . . . .	3-121
3.3.1.4	North American Aviation Erecting System for Tail Sitter Airplane, 1956 . . . . .	3-122
3.3.1.5	Focke-Wulf FW860 Self-Erecting VATOL Light Recce-Fighter . . . . .	3-124
3.3.1.6	Hiller Helicopters Single Place Tail Sitter Concept, 1950 . . . . .	3-126
3.3.1.7	Northrop Articulating Cockpit for Design N336-12 . . . . .	3-127
3.3.1.8	Focke-Wulf FW860 Self-Erecting VATOL Operation . . . . .	3-128
3.3.1.9	North American Aviation VATOL (Tail Sitter) Concept with Tilting Nose and Fold-Out Lift Engines, 1956 . . . . .	3-130
3.3.2.1	Ryan Aeronautical Company X-13 Approaching Landing Platform at Edwards AFB, 1957 . . . . .	3-132

LIST OF FIGURES (continued)

<u>FIGURE NO.</u>	<u>DESCRIPTION</u>	<u>PAGE</u>
3.3.2.2	Ryan Test Bed for Exploring Vertical Flight Control-Gimbaled Nozzle and Wing Tip Reaction Jets . . . . .	3-134
3.3.2.3	Ryan VTOL Test Bed with Cockpit, "Wings" and Pilot in Hovering Flight . . . . .	3-135
3.3.2.4	Capability Required of Ryan X-13 VATOL Airplane . . . . .	3-137
3.3.2.5	Ryan X-13 with Conventional Landing Gear . . . . .	3-138
3.3.2.6	Ryan X-13 In Flight with VTOL "Pogo" Type Undercarriage . . . . .	3-139
3.3.2.7	Ryan X-13 General Arrangement . . . . .	3-141
3.3.2.8	Cutaway Perspective of Ryan X-13 . . . . .	3-142
3.3.2.9	Ryan X-13 Inboard Profile . . . . .	3-143
3.3.2.10	Ryan X-13 Chin Hook in Engaged Position on Cable. Pilot Seat Tilted Forward . . . . .	3-145
3.3.2.11	Ryan X-13 View Looking Down on Airplane Hanging from Platform Cable . . . . .	3-146
3.3.2.12	Ryan X-13 Upward Ejection Seat . . . . .	3-148
3.3.2.13	Ryan X-13 Attitude Stabilization System . . . . .	3-153
3.3.2.14	Ryan X-13 Operation from Flatbed Trailer Platform . . . . .	3-156
3.3.2.15	Ryan X-13 Flatbed Trailer in Horizontal Position . . . . .	3-157
3.3.2.16	Ryan X-13 Actual Take-Off Sequence . . . . .	3-158
3.3.2.17	Ryan X-13 Basic Flight Test Missions . . . . .	3-160
3.3.2.18	Ryan X-13 Estimated Performance . . . . .	3-161
3.3.3.1	ONECMA Coleopter Supersonic Fighter . . . . .	3-168

LIST OF FIGURES (continued)

<u>FIGURE NO.</u>	<u>DESCRIPTION</u>	<u>PAGE</u>
3.3.3.2	Propulsive Ring-Wing Concepts Covered in Helmut G. von Zborowski's French Patent No. 1,051,259 . . . . .	3-169
3.3.3.3	SNECMA C.450.01 Coleopter . . . . .	3-171
3.3.3.4	SNECMA "Flying ATAR" Testbeds C.400 P.2 and C.400 P.1 . . . . .	3-174
3.3.3.5	Elements of the SNECMA Supersonic Coleopter Fighter . . . . .	3-176
3.3.3.6	The Coleopter Ramjet Configuration . . . . .	3-178
3.3.3.7	SNECMA Spoiler System for Engine Thrust Modulation and Thrust Vectoring . . . . .	3-181
3.3.3.8	SNECMA Concepts for Roll Control Using Engine Efflux . . . . .	3-181
3.3.3.9	General Arrangement SNECMA Coleopter C.450.01 . . . . .	3-183
3.3.3.10	Major Elements of the SNECMA Coleopter C.450 (Earlier Design) . . . . .	3-184
3.3.3.11	Exploded View of SNECMA C.450.01 Coleopter . . . . .	3-185
3.3.3.12	SNECMA ATAR E-5V Used in C.450.01 Coleopter . . . . .	3-187
3.3.3.13	Thrust vs. Airspeed SNECMA ATAR E-5 Turbojet Engine . . . . .	3-189
3.3.3.14	SNECMA C.450.01 Ring-Wing Structure . . . . .	3-191
3.3.3.15	SNECMA C.450.01 All-Moving Tail . . . . .	3-193
3.3.3.16	SNECMA C.450.01 Oleo-Pneumatic Landing Gear Assembly . . . . .	3-193
3.3.3.17	SNECMA C.450.01 Fuselage-to-Wing Attachment Strut . . . . .	3-193
3.3.3.18	SNECMA C.450.01 Cockpit . . . . .	3-195
3.3.3.19	SNECMA C.450.01 Tilting Seat and Controls . . . . .	3-196

LIST OF FIGURES (continued)

<u>FIGURE NO.</u>	<u>DESCRIPTION</u>	<u>PAGE</u>
3.3.3.20	SNECMA C.450.01 Stabilization and Control System . . . . .	3-199
3.3.3.21	SNECMA Coleopter Translational Motion and Jet Deflection Sequence . . . . .	3-200
3.3.3.22	SNECMA C.450.01 VTOL and Transition Flight Maneuvers . . . . .	3-203
3.3.3.23	SNECMA Coleopter Ground Handling and Maintenance Concept . . . . .	3-204
3.3.3.24	SNECMA C.450.01 on Flatbed Trailer and Erecting Process . . . . .	3-205
3.3.3.25(a)	SNECMA C.450.01 with Trailer and Maintenance Shelter--Vertical Position . . . . .	3-208
3.3.3.25(b)	SNECMA C.450.01 Engine Removal on Trailer--Horizontal Position . . . . .	3-208
3.3.3.26	SNECMA Model Test Apparatus for Determining Vertical Flight Control Power . . . . .	3-210
3.3.3.27	SNECMA Coleopter Pulse-Jet Powered Model in Free Flight . . . . .	3-210
3.3.3.28	SNECMA Coleopter Pulse-Jet Powered Model with Ring Wing . . . . .	3-210
3.3.3.29	SNECMA C.400 P.1 In Test Rig to Check Control and Stabilization Systems . . . . .	3-212
3.3.3.30	SNECMA C.400 P.3 Test Apparatus Simulated Vertical Descent Test . . . . .	3-212
3.3.3.31	SNECMA Oscillation Test Rig . . . . .	3-214
3.3.3.32	SNECMA C.400 P.1 Radio Controlled Flying Testbed . . . . .	3-215
3.3.3.33	SNECMA C.400 P.1 Testbed Hovering Under Safety Gantry . . . . .	3-216
3.3.3.34	Components of SNECMA (ATAR Velant) C.400 P.2 . . . . .	3-218
3.3.3.35	SNECMA C.400 P.2 In Free Hovering Flight . . . . .	3-219

LIST OF FIGURES (continued)

<u>FIGURE NO.</u>	<u>DESCRIPTION</u>	<u>PAGE</u>
3.3.4.1	DTNSRDC XBQM-108A VATOL Remotely Piloted Vehicle in CTOL Position . . . . .	3-226
3.3.4.2	DTNSRDC XBQM-108A General Arrangement . . . . .	3-227
3.3.4.3	DTNSRDC XBQM-108A $C_L$ - $C_D$ Characteristics . . . . .	3-228
3.3.4.4	DTNSRDC XBQM-108A Thrust Vectoring Control Vane Assembly . . . . .	3-231
3.3.4.5	DTNSRDC XBQM-108A Static Longitudinal Pitching Moment Characteristics . . . . .	3-235
3.3.4.6	DTNSRDC XBQM-108A Lateral-Directional Stability Characteristics . . . . .	3-235
3.3.4.7	DTNSRDC XBQM-108A In Tethered Hover Test . . . . .	3-238
3.3.4.8	DTNSRDC Tethered Test System for XBQM-108A . . . . .	3-239
3.3.4.9	DTNSRDC XBQM-108A Shipboard Launch and Retrieval Concept . . . . .	3-241
3.3.5.1.1	Transition of YF-16 VATOL Model In NASA Langley 40' x 80' Wind Tunnel . . . . .	3-249
3.3.5.1.2	YF-17 Model in VTOL Position . . . . .	3-250
3.3.5.2.1	General Arrangement Temco Model 39 . . . . .	3-252
3.3.5.2.2	Combat Mission Profile Temco Model 39 . . . . .	3-253
3.3.5.2.3	Time History of Take-Off and Landing for Temco Model 39 . . . . .	3-257
3.3.5.2.4	Inboard Profile Temco Model 39 . . . . .	3-258
3.3.5.2.5	Pilot and Seat Positions in Conventional and in Vertical Mode Flight, Temco Model 39 . . . . .	3-260
3.3.5.2.6	Instrument Panel Arrangement Temco Model 39 . . . . .	3-261
3.3.5.2.7	J-71 Engine and Turbo-Fan Installation Temco Model 39 . . . . .	3-263
3.3.5.3.1	Convair VATOL Configuration IVA . . . . .	3-271

LIST OF FIGURES (continued)

<u>FIGURE NO.</u>	<u>DESCRIPTION</u>	<u>PAGE</u>
3.3.5.3.2	Control Method Selected by Convair for VATOL Light Weight Day Fighter . . . . .	3-274
3.3.5.3.3	Pivoting Ventral Fin and Under- carriage Arrangement Convair Configuration IVA . . . . .	3-276
3.3.5.3.4	Inboard Profile Convair Configuration IVA . . . . .	3-277
3.3.5.4.1	General Arrangement, Lockheed CL-295-1 Dependent VATOL Airplane Design with Wright TJC32C4 Turbojet Engine . . . . .	3-283
3.3.5.4.2	General Arrangement, Lockheed CL-295-3 Dependent VATOL Airplane Design with GE X-84 Turbofan Type Engine . . . . .	3-284
3.3.5.4.3	General Arrangement Lockheed CL-295-4 Independent VATOL Airplane Design with GE X-84 Engine . . . . .	3-285
3.3.5.4.4	General Arrangement, Lockheed CL-295-2 Independent VATOL Airplane Design with GE J79-X207 Engine . . . . .	3-286
3.3.5.4.5	Lockheed VATOL Airplane Design Vane System for Low Speed and Vertical Flight Control . . . . .	3-292
3.3.5.4.6	Lockheed CL-295-1 VATOL Airplane Design Cockpit Arrangement . . . . .	3-295
3.3.5.4.7	Lockheed CL-295-1 VATOL Airplane Design Forward Fuselage Showing Auxiliary Air Inlet System . . . . .	3-296
3.3.5.4.8	Two Mast System for use with Lockheed Dependent Airplanes . . . . .	3-299
3.3.5.4.9	Two Mast Ground Handling Apparatus - Face View, Lockheed Dependent Airplane . . . . .	3-300
3.3.5.4.10	Two Mast Ground Handling Apparatus - Side View, Lockheed Dependent Airplane . . . . .	3-301
3.3.5.4.11	Three Mast System for use with Lockheed Dependent Airplanes . . . . .	3-302
3.3.5.4.12	Pitch Control Van System for Low Speed and Vertical Flight, Lockheed CL-295-1 . . . . .	3-306

LIST OF FIGURES (continued)

<u>FIGURE NO.</u>	<u>DESCRIPTION</u>	<u>PAGE</u>
3.3.5.4.13	Lockheed Self-Erecting System for Independent Airplane . . . . .	3-308
3.3.5.4.14	Detail of Folding Ventral Fin - Lockheed CL-295-4 Self-Erecting Airplane . . . . .	3-309
3.3.5.5.1	Air Force Light Day Fighter Mission Requirement . . . . .	3-316
3.3.5.5.2	Air Force Dispersed Site Fighter-Bomber Basic Mission Profile . . . . .	3-319
3.3.5.5.3	Ryan Model 115 Dispersed Site Fighter-Bomber 3-View . . . . .	3-325
3.3.5.5.4	Ryan Model 115C Dispersed Site Fighter-Bomber, 3-View . . . . .	3-326
3.3.5.5.5	Ryan Model 115 Dispersed Site Fighter-Bomber Inboard Profile . . . . .	3-328
3.3.5.5.6	Weight Distribution for Three Configurations of the Ryan Model 115C Dispersed Site Fighter-Bomber . . . . .	3-331
3.3.5.5.7	Basic Bombing Mission Profiles for the Three Configurations of the Ryan Model 115C Dispersed Site Fighter-Bomber . . . . .	3-332
3.3.5.5.8	Point Interception Mission Profile (Single Head-On Pass) for the Three Configurations of the Ryan Model 115C Dispersed Site Fighter-Bomber . . . . .	3-333
3.3.5.5.9	Maximum Airspeed Variation with Altitude at Combat Weight for the Three Configurations of the Ryan Model 115C Dispersed Site Fighter-Bomber . . . . .	3-334
3.3.5.5.10	VTOL Take-Off and Landing Unit for the Ryan Model 115C Dispersed Site Fighter-Bomber . . . . .	3-335
3.3.5.5.11	Ground Apparatus for the Ryan Model 115 VATOL Airplane . . . . .	3-337
3.3.5.5.12	Weapon System Development Program for the Ryan Model 115C Dispersed Site Fighter-Bomber . . . . .	3-338

LIST OF TABLES

<u>TABLE NO.</u>	<u>DESCRIPTION</u>	<u>PAGE</u>
1.1	Developed Experimental VTOL and V/STOL Aircraft Thru 1980 . . . . .	1-12
1.2	Static Thrust Characteristics of Propulsion Systems . . . . .	1-19
2.1.1	Rocket-Powered VTOL Vehicle Projects . . . . .	2-8
2.1.2	Developed Rocket-Powered Individual Lift Devices . . . . .	2-10
2.2.2.1	Chronology of Bell Aerosystems' Rocket Belt Development . . . . .	2-18
2.2.2.2	Specifications of Bell Aerosystems Rocket Belt . . . . .	2-24
2.2.3.1	SRLD Design Specification . . . . .	2-31
2.2.4.1	Thiokol RMD Jump Belt (SRLD) Demonstrator Characteristics . . . . .	2-40
2.3.2.1	Characteristics of Sud-Aviation Ludion . . . . .	2-60
3.1.1	Turbojet/Turbofan Aircraft Included in Section 3 . . . . .	3-11
3.2.2.1	Chronology of Bell Aerosystems Jet Belt Development . . . . .	3-20
3.2.2.2	Characteristics of Williams Research WR-19 Engine . . . . .	3-26
3.2.3.1	Chronology of Marine Corps STAMP and Army ILD Programs . . . . .	3-32
3.2.3.2	Contracts for STAMP Program . . . . .	3-35
3.2.3.3	Target Design Specifications for STAMP . . . . .	3-37
3.2.3.2.1	U.S. Government Funding of Bell and Williams Jet Belt/Jet Platform Development . . . . .	3-41
3.2.3.2.2	Information on Williams International WASP I and WASP II . . . . .	3-42

LIST OF TABLES

<u>TABLE NO.</u>	<u>DESCRIPTION</u>	<u>PAGE</u>
3.2.3.2.2.1	WASP II Principal Performance Characteristics . . . . .	3-52
3.2.3.2.2.2	WASP II Weight Breakdown . . . . .	3-62
3.2.3.2.2.3	Williams WASP II Actual Fuel Flow and Endurance Summary . . . . .	3-63
3.2.3.3.1	AiResearch STAMP Vehicle Fan Characteristics . . . . .	3-81
3.2.3.3.2	Vertical Lift Performance of AiResearch STAMP Vehicle . . . . .	3-82
3.2.3.5.1	Primary Requirements Used by Piasecki Aircraft in the Preliminary Design, Model 159B . . . . .	3-102
3.2.3.5.2	Weight and Performance Summary Piasecki Model 159B . . . . .	3-110
3.3.2.1	Ryan X-13 Chronology . . . . .	3-131
3.3.2.2	Engine Thrust, Losses and Net Thrust (S.L. Standard Day), X-13 . . . . .	3-147
3.3.2.3	Net Thrust and Roll Control Thrust Vs. Temperature and Altitude, X-13 . . . . .	3-149
3.3.2.4	Weight Breakdown of X-13 . . . . .	3-150
3.3.3.1	Coleopter Chronology . . . . .	3-172
3.3.3.2	C.450.1 Principal Characteristics . . . . .	3-186
3.3.3.3	SNECMA ATAR E-5 Engine Characteristics . . . . .	3-188
3.3.3.4	SNECMA C.450.1 Ground Handling Trailer Characteristics . . . . .	3-202
3.3.4.1	XBQM 108A Characteristics . . . . .	3-229
3.3.4.2	Estimated Control Powers Available For XBQM 108A . . . . .	3-233
3.3.4.3	XBQM 108A Force and Moment Characteristics at 90° Angle of Attack . . . . .	3-234

LIST OF TABLES

<u>TABLE NO.</u>	<u>DESCRIPTION</u>	<u>PAGE</u>
3.3.4.4	Mission Capabilities of XBQM-108A with Turbofan Engine . . . . .	3-242
3.3.5.1	VATOL Aircraft Designs Reviewed . . . . .	3-245
3.3.5.2	Summary of VATOL Aircraft Design Characteristics . . . . .	3-246
3.3.5.2.1	Performance Summary TEMCO Model 39 . . . . .	3-254
3.3.5.2.2	Characteristics of TEMCO Model 39 . . . . .	3-255
3.3.5.3.1	Performance Summary Convair Configuration IVa . . . . .	3-272
3.3.5.3.2	Characteristics of Convair Configuration IVa . . . . .	3-272
3.3.5.4.1	Weight, Thrust and Dimension Summary Lockheed VATOL Day Fighter Designs . . . . .	3-287
3.3.5.4.2	Performance Summary Lockheed CL-295-1 and CL-295-4 Designs . . . . .	3-288
3.3.5.5.1	Performance Requirements for Dispersed Site Fighter-Bomber (Primary Requirements) . . . . .	3-318
3.3.5.5.2	Weight Comparison of Ryan Hanging and Tail-Sitter Designs . . . . .	3-320
3.3.5.5.3	Ryan Aeronautical Estimates of Weight Empty and Fuel Required for the Primary Interest Mission, Hanging VATOL Aircraft Designs . . . . .	3-322

## SECTION 1

### INTRODUCTION AND BACKGROUND

The Wright Brothers undertook their successful development of the powered airplane using the horizontal or "conventional" take-off and landing (CTOL) approach, a solution necessary for flight with the low power-to-weight ratios possible at the time. However, many earlier advocates believed that powered aircraft would actually be based on the vertical takeoff and landing (VTOL) principle. Among the most notable of these early proponents were Leonardo da Vinci, who sketched the first helicopter in 1490 (Figure 1.1) and Sir George Cayley, who proposed a combination helicopter and airplane in 1809 (Figure 1.2), where the rotors converted to flat, disc-shaped fixed wings through the use of blade feathering. Cayley is considered to be the "Father of British Aviation".

Contrary to the expectation that the CTOL airplane's success would have dampened interest in the VTOL solution, that success actually spurred an increase in VTOL activity both in the helicopter and other-than-helicopter approaches. The first flyable but not really practical helicopter actually appeared in 1930 (d'Ascanio) to be followed by the successful Focke FW61 and Sikorsky VS-300 machines, making their first flights in 1936 and 1940 respectively. However, the first VTOL airplane, the Convair XFY-1, did not fly until 1953. Even before this 1953 historical benchmark, various patents and development efforts anticipated the aircraft that have been built and flown since then and the following examples taken from Reference 1.1 are noteworthy. In 1921 Hall and Matthews proposed a fan-in-wing approach (Figure 1.3) and a unique rotor-wing airplane (Figure 1.4) was revealed by R. P. Pescara in 1922. In that same year W. Margoulis, Director of the French Eiffel Laboratory, published a description of a tilting-propeller airplane (Figure 1.5). Science and Invention magazine of June 1924 presented Ramon Oriol's "Vertical Attitude Take Off and Landing (VATOL)" airplane (Figure 1.6) and even the Hawker-Siddeley Harrier vectored thrust concept was proposed, in very rudimentary form, by Jean de Chappedelaine in 1926 (Figure 1.7). He visualized turbo-blowers on the fuselage sides with mixing of the engine exhaust and blower airflow; the efflux was to be directionally controllable to vector the thrust from vertically upward to fore or aft for translational flight. Vectoring was to be accomplished by rotating the blower's outer casing. J. C. Johnson, in 1929, demonstrated a stoppable rotor airplane (Figure 1.8) flown successfully in the ultra-STOL mode. Although this was not designed for VTOL, it had the rudiments

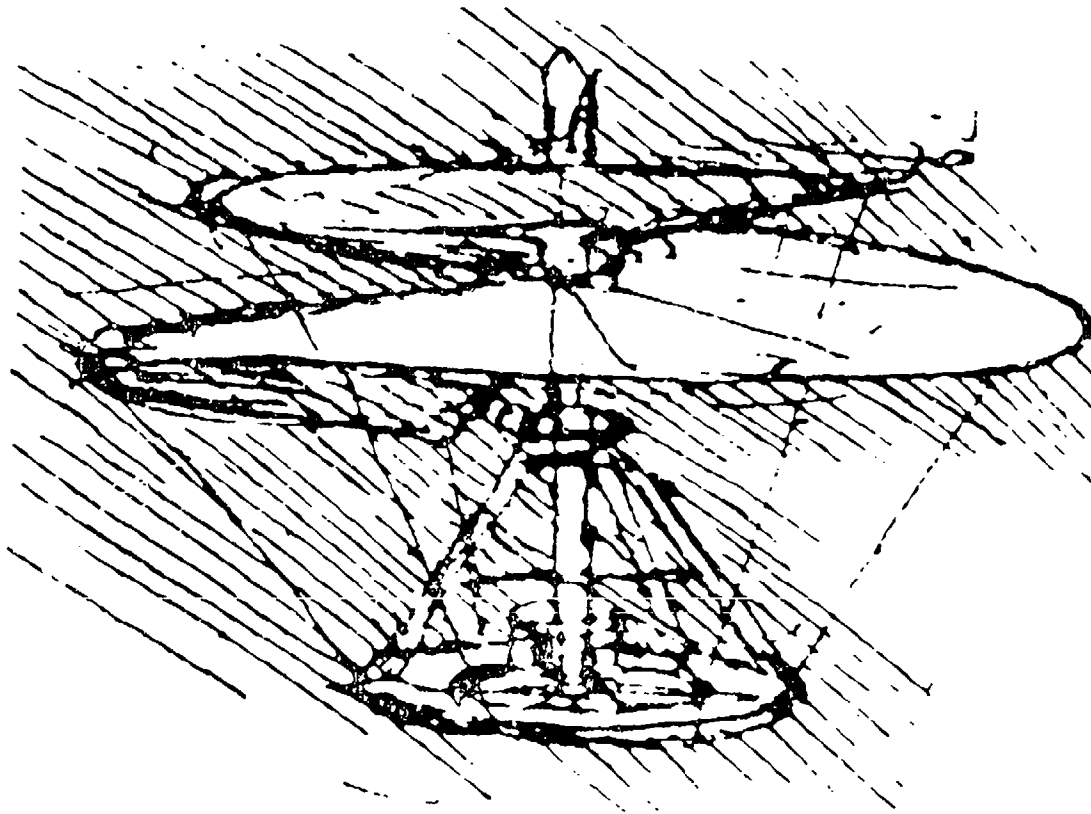

Figure 1.1 Leonardo da Vinci's Vertical Lift Machine  
(Helicopter), 1490

(Courtesy: Thomas Y. Crowell Company, Inc.  
Publisher of Flight Through the Ages by  
C.H. Gibbs-Smith)

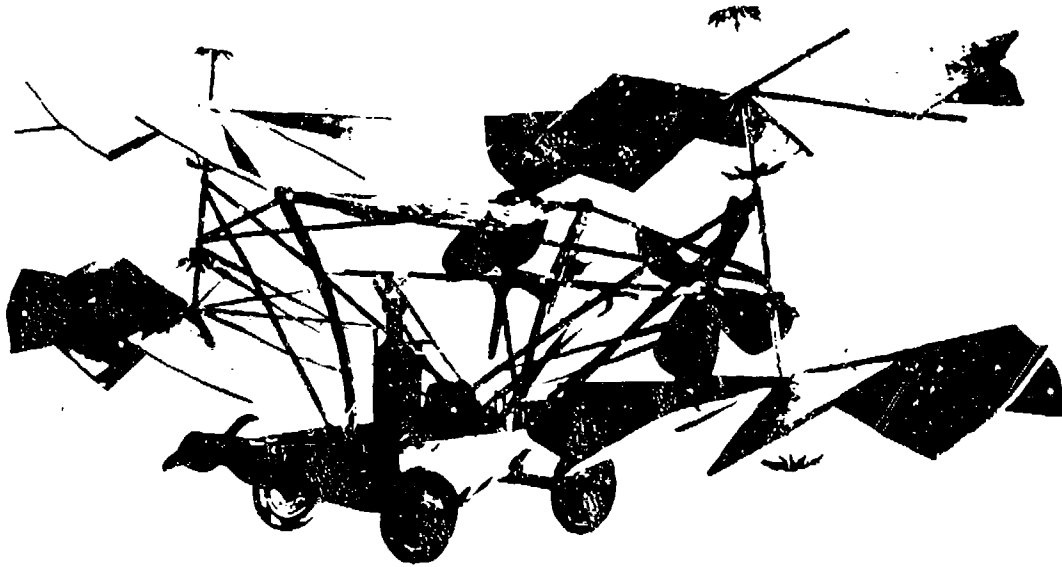

Figure 1.2 Sir George Cayley's Combined Helicopter - Airplane  
Concept, 1809 (Courtesy: Smithsonian Institution)

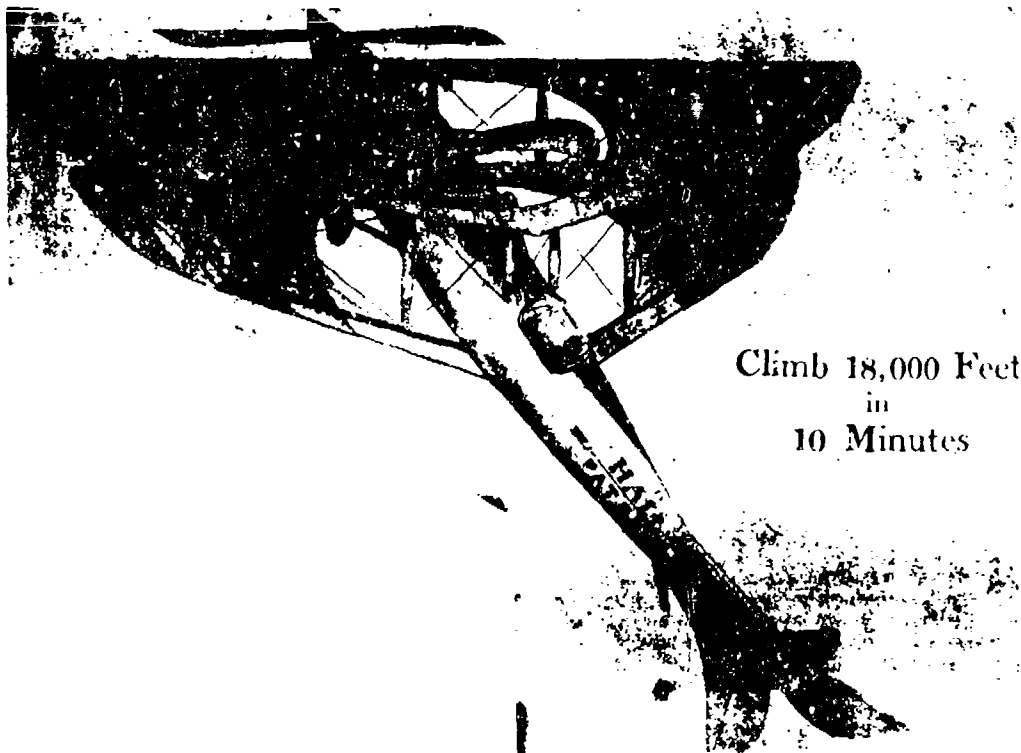

Figure 1.3 Hall-Matthews In-in-Wing Airplane  
Concept, 1921 (from Reference 1.1)



Figure 1.4 Stoppable Rotor (Rotor-Wing) Airplane Concept by  
R. P. Pescara, 1922 (from Reference 1.1)

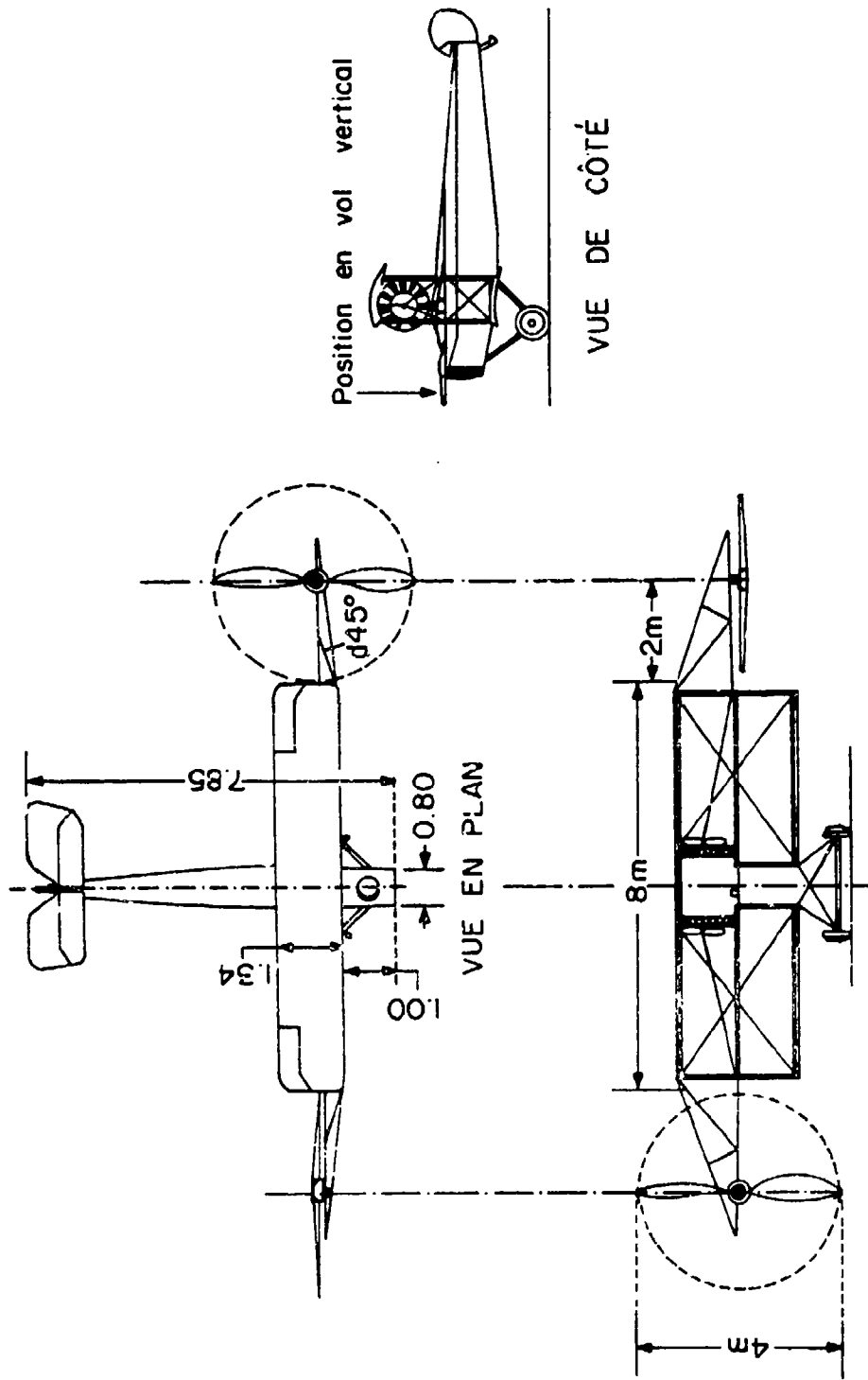
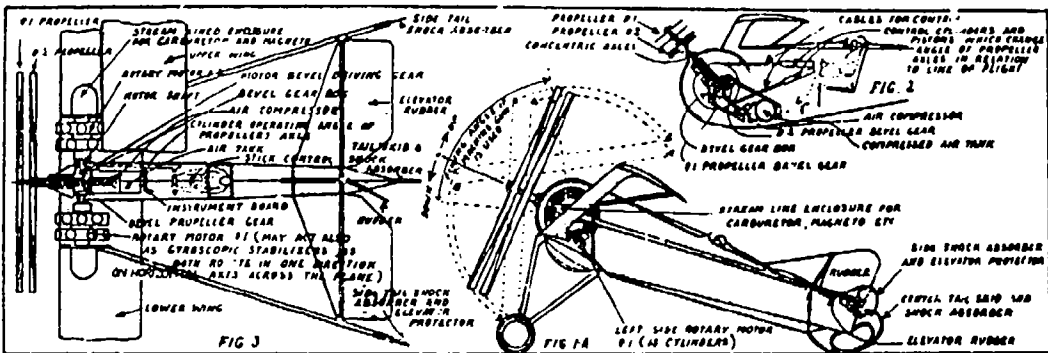
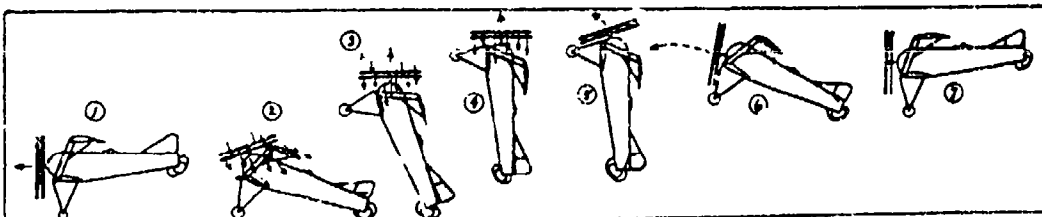

Figure 1.5 W. Margoulis Tilting-Propeller Airplane Concept, 1922 (from Reference 1.1)

# Airplane-Helicopter Flyer



The small plane with the aid of two large propellers rotating in opposite direction is lifted almost vertically from the ground by tilting the propellers to a horizontal angle. The length of the propellers is one-third of the wing length. The motors that drive them through bevel gears are of the rotary variety and are mounted outside the fuselage for cooling. The plane is equipped with both horizontal and vertical rudders which are controlled by cables to the stick and wheel. The propeller angle is changed by air cylinders.



Above is shown the angle of tilt of the propellers used in raising the plane from the ground tilted straight up first and then down to pull the plane into horizontal flight as it rises. Below - method of landing. As plane nears ground it is suddenly nosed upward to check forward speed. The propellers are slowed down so plane lands on tail. - Ramon Oriol.

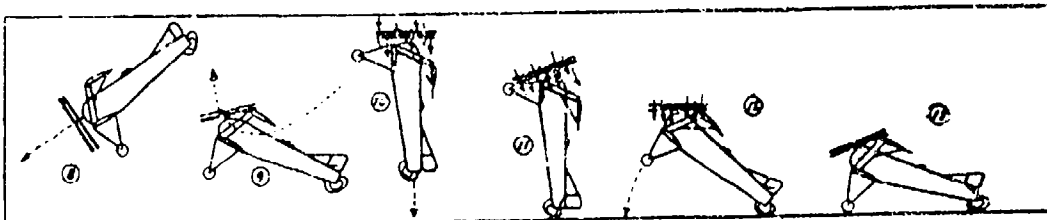

Figure 1.6 Ramon Oriol's Vertical Attitude Take-Off and Landing Airplane Concept, 1924 (This Reference 1.1)

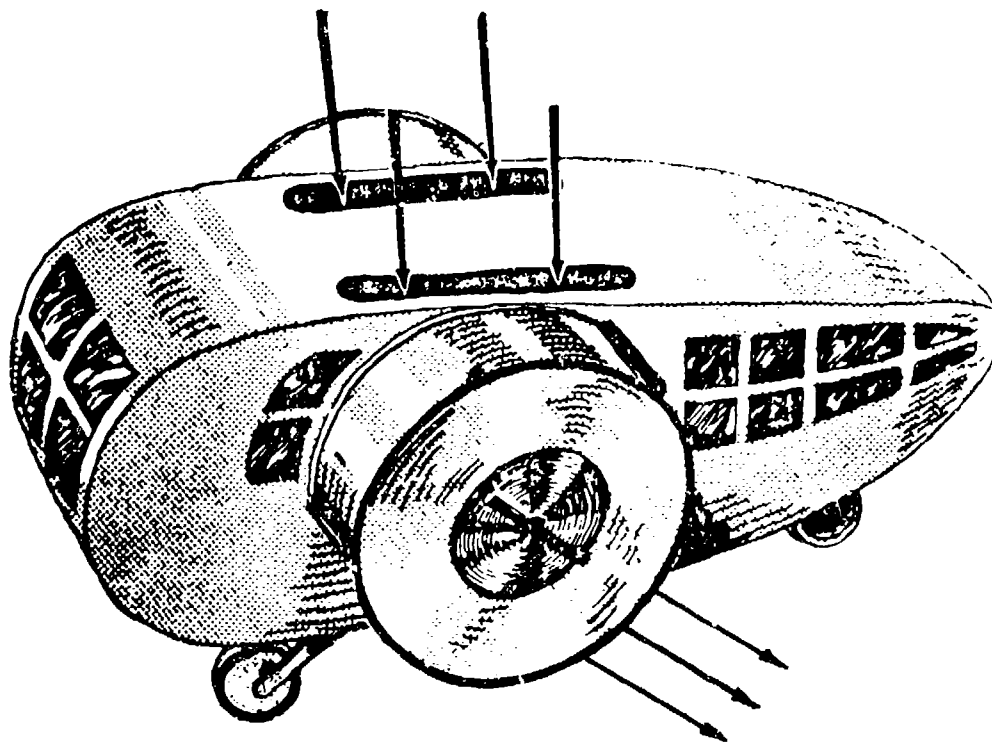

Figure 1.7 Jean de Chappedlaine's Vectored Thrust Concept, 1926 (from Reference 1.1)



Figure 1.8 J. C. Johnson Stoppable Rotor STOL Airplane, Flown in 1929 (from Reference 1.1)

for such operation. Another form of stoppable rotor aircraft was initiated by Gerard P. Herrick in 1927 culminating in his "Convertaplane," the model HV-2A (Figure 1.9). This was tested with limited success in 1937 as an autogyro (unpowered rotor). However, Herrick did consider a powered rotor system to provide VTOL. The final example of an early VTOL aircraft concept is General Electric's tilting prop-rotor machine shown diagrammatically in Figure 1.10. Efforts to develop this concept took place between 1940 and 1945.

The helicopter was the first form of VTOL aircraft to achieve success and it has developed into a highly useful and versatile vehicle for hover, low speed, and short range operations, but its inherent speed and cruise efficiency limitations made it an unacceptable replacement for the conventional airplane. Paradoxically, the very success of the helicopter convinced a number of aircraft developers that the faster, more cruise-efficient VTOL airplane<sup>1</sup> was a realizable and better solution and that it could find both military and commercial markets. However, not until after World War II did operable forms of VTOL aircraft begin to emerge, their practical realization being made possible by the newly available turbine engines with their outstandingly high power-to-weight ratios. While it was possible to develop piston engine-powered VTOL machines, these required helicopter-type rotors to produce enough lift for vertical flight. The Bell XV-2 is an example of such a solution. These piston engine airplanes, however, had unacceptably high empty weight fractions, substantially higher than that of the helicopter, and were not capable of providing economically viable operational VTOL systems.

The modern VTOL airplane era began in the early 1950's with the development of the turboprop-equipped "Pogo" tail-sitting machines by Convair (XFV-1) and Lockheed (XFV-1) for the U.S. Navy. Since then, a variety of concepts has been proposed, ranging from those using helicopter-type rotors to those relying on rocket thrust for vertical flight. A considerable number have been developed, and surprisingly, most flew with varying degrees of success. Figure 1.11 and Table 1.1 give a chronological picture of these efforts.

Regardless of the degree of success achieved, knowledge about the various concepts and their associated development efforts is helpful in the generation of new concepts, evaluation of research and development plans, and in avoiding pitfalls during the creation of new VTOL aircraft. Hence, within the limitations imposed by proprietary rights, security

---

<sup>1</sup>As used in this document, VTOL and V/STOL aircraft are defined as vehicles capable of taking off and landing vertically while retaining cruise efficiencies and speeds approximately equal to those of conventional airplanes.

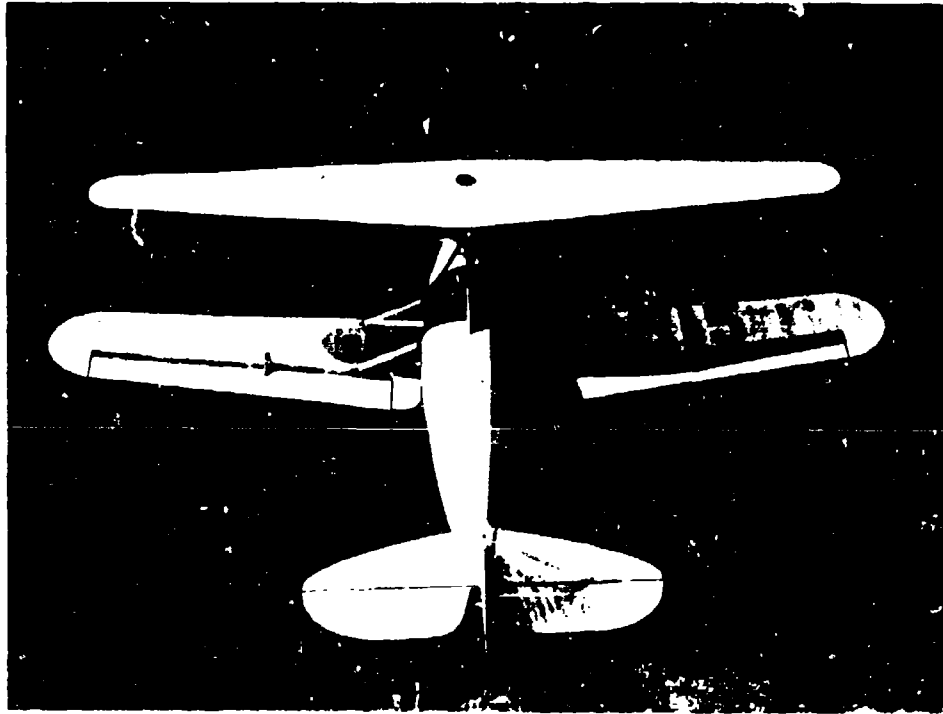

Figure 1.9 Gerard P. Herrick HV-2A Stoppable Rotor  
(Rotor-Wing) Autogyro-Airplane, Flown in  
1937

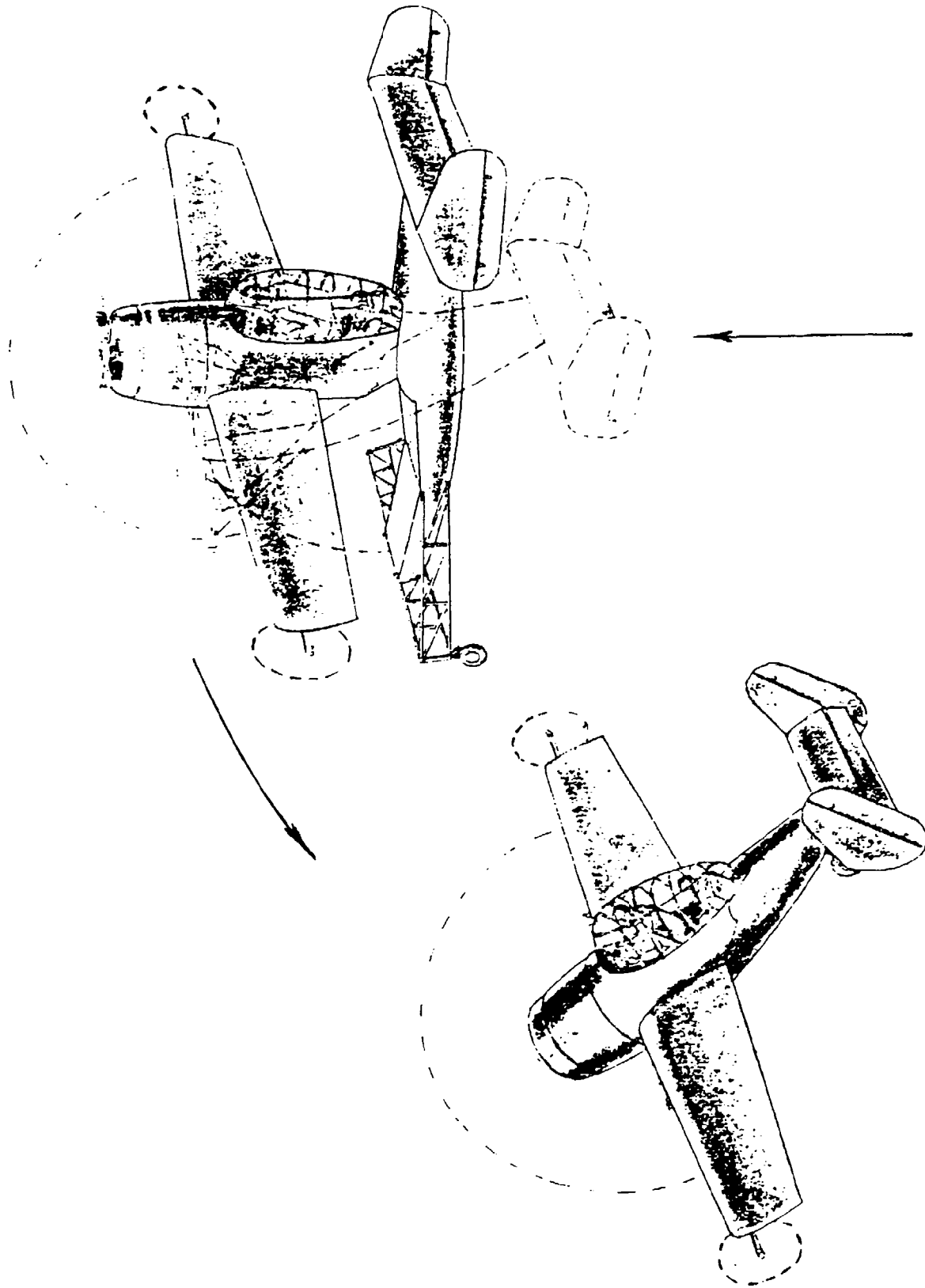

Figure 1.10 General Electric "Heliplane" Concept, Helicopter to Airplane Transition (from Reference 1.7)

DEVELOPED EXPERIMENTAL V/STOL AIRCRAFT

DATE OF FIRST V/STOL FLIGHT

	1950	1955	1960	1965	1970	1975	1978
CONVAIR TAIL XY-1 SITTERS		LOCKHEED XF-119	RYAN X-13	SNECCA C-450			
DEFLECTED SLIPSTREAM			RYAN VZ-3RV				
TILT WING			VERTOL VZ-7PH HILLER X-18	LIV RYAN XC-142A CANADAIR CL-94			
TILT PROP ROTOR & DUCTED PROP		BELL XV-3	DOAK VZ-4DA	CURTISS WRIGHT X-100 & X-19	BELL X-27A		BELL XV-15
LIFT FAN			AVROCAR VZ-9	RYAN XV-5A			
JET EJECTOR				LOCKHEED XV-4A			
TILTING JET ENGINES		BELL XV-7		RYAN XV-5B VRSJUD VJ100C			
VECTORED THRUST JET ENGINES		BELL X-14	HAWKER P-1127		SOVIET MIKOYAN DO-31	SOVIET YAK-36 VFW VAK-1918	
LIFT ENGINES + CRUISE ENGINES			SHORT SC-1	DASSAULT BALZAC	DASSAULT MIRAGE IIIV		

\*NOT NUMBERED

Figure 1.11 Chronology of Developed Experimental V/STOL Airplanes

**TABLE 1.1**  
**DEVELOPED EXPERIMENTAL VTOL AND V/STOL AIRCRAFT THRU 1980**

Company	Aircraft Designation	Funded by	U.S. Government Contract Dollars (millions)	First Free VTOL Flight	First Complete Transition
1. AVRO (Canada)	AVROCAR (VA-9)	U.S. Army/Air Force	6.3	Jan 1961	Not transitioned, only slow speed flight in ground effect performed
2. Bell Aerospace	ATV	Company	0	Nov 16, 1954	NA
3. Bell Aerospace	X-14	U.S. Air Force	2.2	Feb 19, 1957	May 24, 1958
4. Bell Aerospace	X-22A	U.S. Tri-Service	25.0	Mar 17, 1966	Mar 1, 1967
5. Bell Helicopter	XV-3	U.S. Army/Air Force	9.8	Aug 23, 1955	Dec 1958
6. Bell Helicopter	XV-15	U.S. Army/Navy/MASA	44.0 thru Aug '80	May 1977	July 24, 1979
7. Boeing-Vertol	VZ-2PH	U.S. Army/Navy	2.0	Apr 1957	July 1958
8. Canadair (Canada)	CL-84	Canadian Army	0	May 7, 1965	Jan 17 1968
9. Convair (S.D.)	XFY-1 (Pogo)	U.S. Navy	20.0	Aug 2, 1954	Nov 2, 1954
10. Curtiss-Wright	X-100	Company	0	Apr 1960	Apr 1960
11. Curtiss-Wright	X-19A	Company & Tri-Service	12.0	June 26, 1964	crashed during partial transition
12. Dassault (France)	Balzac V	French Government	0	Oct 18, 1962	Mar 18, 1963
13. Dassault (France)	Mirage III V	French Government	0	Feb 12, 1965	June 22, 1966
14. Doak Aircraft	VZ-40A	U.S. Army	3.5	Dec 1958	May 4, 1959
15. Dornier (Fed. Rep. Germany-FRG)	DO-31E	FRG	0	July 14, 1967	Dec 16, 1967
16. EWR-SUD (FRG)	VJ-101C	FRG	0	Apr 10, 1963	Sept 20, 1963
17. Hawker Siddeley (Brit. Aerosp.)	P-1127 (Krestrel)	U.K.	20.0	Nov 19, 1960	Sept 12, 1961
18. Hiller	X-18	U.S. Air Force	6.0	No VTOL attempted	Nov 1959*
19. Ling-Temco-Vought	XC-142A	U.S. Tri-Service	147.4	Dec 29, 1964	Jan 11, 1965
20. Lockheed	XFV-1 (Pogo)	U.S. Navy	20.0	**	Apr 1954
21. Lockheed	XV-4A	U.S. Army	3.5	Nov 30, 1962	Nov 8, 1963
22. Lockheed	XV-4B	U.S. Air Force	6.3	No VTOL attempted	crashed during conventional flight - 1969
23. Yakovlev (U.S.S.R.)	"Freehand"	USSR	0	1965 (est.)***	NA
24. Rockwell International	XFV-12A	U.S. Navy	85 (approx.) thru Dec 1980	not flown, program terminated May 1981	
25. Ryan Aeronautical	X-13	U.S. Air Force	12.3	May 28, 1956	Nov 28, 1956
26. Ryan Aeronautical	VZ-3RY	U.S. Army	2.5	{ Incapable of hover Min. Speed = 15Kt	Jan 21, 1959 first flight
27. Ryan Aeronautical	XV-5A	U.S. Army	20.0	July 16, 1964	Nov 5, 1964
28. Ryan Aeronautical	XV-5B	NASA	1.0	June 24, 1968	NA
29. Short Brothers (United Kingdom)	SC-1	U.K.	0	Oct 1958	Apr 6, 1960
30. SNECMA (France)	C.450.01	Company	0	Feb 1960 (crashed)	not accomplished
31. VFW (FRG)	VAK-191B	FRG	0	Oct 1971	Oct 1972
32. Yakovlev (U.S.S.R.)	VAK-36	U.S.S.R.	0	Mar 1974	NA

\*Conventional T.O. only, partial transition made between Nov. 1959 and July 1961.  
 \*\*No VTOL's attempted from ground; all hover, vertical climb and descent done at altitude after conversion.  
 \*\*\*Flown at Domodedovo Air Show, July 1967  
 NA-Not available.

and material available for review, a substantially comprehensive coverage of the known concepts and associated development efforts is presented in this report.

Figure 1.11 shows that, up to 1978, at least 29 different experimental VTOL airplanes were built and flown; this does not include the various hoverable (engine) test beds and wingless VTOL vehicles. Noteworthy is the prolific activity between 1955 and 1967 contrasted with the relative inactivity during the following years. However, interest in VTOL development had not disappeared; study and research work did continue, albeit on a more selective basis. During the years 1950 to 1979, many studies, analyses, designs, and developments were conducted on V/STOL aircraft for the purpose of meeting selected mission requirements. Over \$450 million has been spent directly on the experimental aircraft by the U.S. Government (see Table 1.1). This does not include the considerable additional funds spent privately by U.S. industry, by the U.S. Government on other V/STOL studies, research and development, and by foreign governments and companies. To date (1985) only one V/STOL aircraft has achieved production, the AV-8 series (Harrier) attack airplane developed in England by Hawker-Siddeley.

A number of factors contributed to the decrease in V/STOL activity during the 1967 and 1978 time period. These were:

1. The decision by the U.S. Air Force not to operate transport airplanes directly into a combat zone. This led to the termination of the medium intra-theater tilt-wing transport development effort based on the XC-142A experience. In 1970 the Air Force opted for short take-off and landing (STOL) transports to move material and troops to airstrips well behind the combat zone, with the Army being expected to complete the delivery using helicopters. This decision led to the Boeing YC-14 and McDonnell-Douglas YC-15 STOL transport developments.

2. The assignment of roles and missions to each of the services by the Department of Defense. As a result, the Army, which had been a leader in V/STOL airplane research and exploratory development, shifted all of its V/STOL efforts to advanced type helicopters, the lone exception being the tilt rotor XV-15.

3. The decision by the U.S. and German governments to cancel the development of the jointly funded US/FRG V/STOL tactical fighter in 1968 because it had become too costly and complex.

4. The lack of any pressing U.S. or NATO requirements for operational V/STOL aircraft systems.

In Europe, V/STOL development also had been worked on vigorously. From 1959 to 1970, the Federal Republic of Germany (FRG) carried out the most ambitious effort resulting in three

different V/STOL airplanes. EWR<sup>1</sup> Sud VJ-101, VFW<sup>2</sup> VAK-191E and Dornier Do-31. Accompanying these efforts were substantial supportive research and development work. Active FRG interest in V/STOL appears to have ceased shortly after completion of the government sponsored V/STOL transport study competition in 1970 and the decision to abandon the US/FRG V/STOL tactical fighter. Except for England, interest also had waned in the other previously active Western countries: Canada, France, and Italy. Some interest in VTOL remotely piloted vehicles existed up to about 1980, principally by Dornier in the Federal Republic of Germany.

Starting in the mid-1970's, the U.S. Navy revived interest in V/STOL and a number of U.S. aerospace organizations were involved in Navy-sponsored studies. Serious consideration was given to the possibility of replacing all or part of the conventional sea-based air force with V/STOL type aircraft beginning in the 1990-2000 time period. Since 1980 Navy interest has diminished. Also, starting in the 1970's the Soviet Union has shown a strong interest in Naval VTOL fighter type aircraft systems as evidenced by their YAK-36 and Kiev type carrier developments.

Following the successful testing of the Bell Helicopter Company XV-15 tilt rotor aircraft during the early 1980's a program to develop a larger machine for multi-service use has been undertaken by the U.S. Department of Defense. This is to be a light utility transport with the Navy being assigned primary responsibility for the development. Designated the V-22, Osprey (formerly JVX) this tilt rotor machine is targeted for production starting in the early 1990's with a considerable number to be procured by the Marine Corps., Navy, Army and Air Force.

In the foregoing paragraphs, the acronyms VTOL and V/STOL have been used interchangeably, although they really should not be. While the early thinking was VTOL oriented, the realization that even short running take-offs could substantially increase the useful load, quickly led to concentration on concepts capable of operating in both the vertical and short take-off and landing modes. Most of the concepts developed since the vertical attitude take-off and landing (VATOL) "Pogo" airplanes of 1950-57 have been of the horizontal attitude type and aimed at V/STOL.

Figures 1.12 and 1.13 show that the variation in V/STOL aircraft concept possibilities is unexpectedly large and numerous studies have shown that no one approach and no one design can be superior in all important considerations and characteristics. Just as with the conventional take-off and landing airplane and the helicopter, it is probable that some approaches eventually will dominate for specific uses (fighter, transport, utility, etc.), particularly as investment in and experience with selected concepts accumulates. However, study and exploration of the various approaches can be expected to continue for many years.

<sup>1</sup> - Entwicklungsring.

<sup>2</sup> - Vereinigte Flugtechnische Werke.

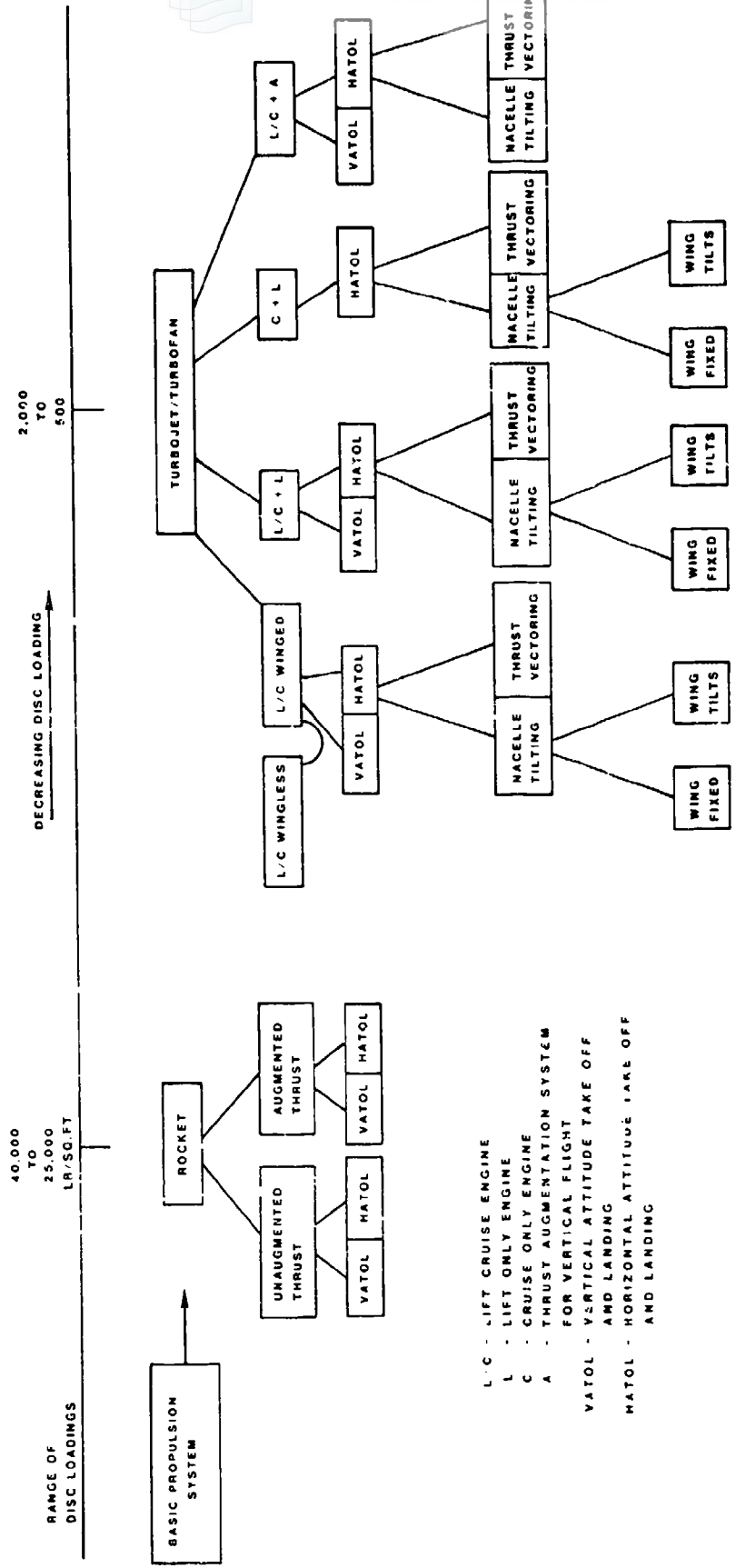

L/C - LIFT CRUISE ENGINE  
 L - LIFT ONLY ENGINE  
 C - CRUISE ONLY ENGINE  
 A - THRUST AUGMENTATION SYSTEM  
 FOR VERTICAL FLIGHT  
 AND LANDING  
 MATOL - HORIZONTAL ATTITUDE TAKE OFF  
 AND LANDING

Figure 1.12 Major Categories of VTOL and V/STOL Vehicles - Rockets and Turbojet/Turbofan Approaches

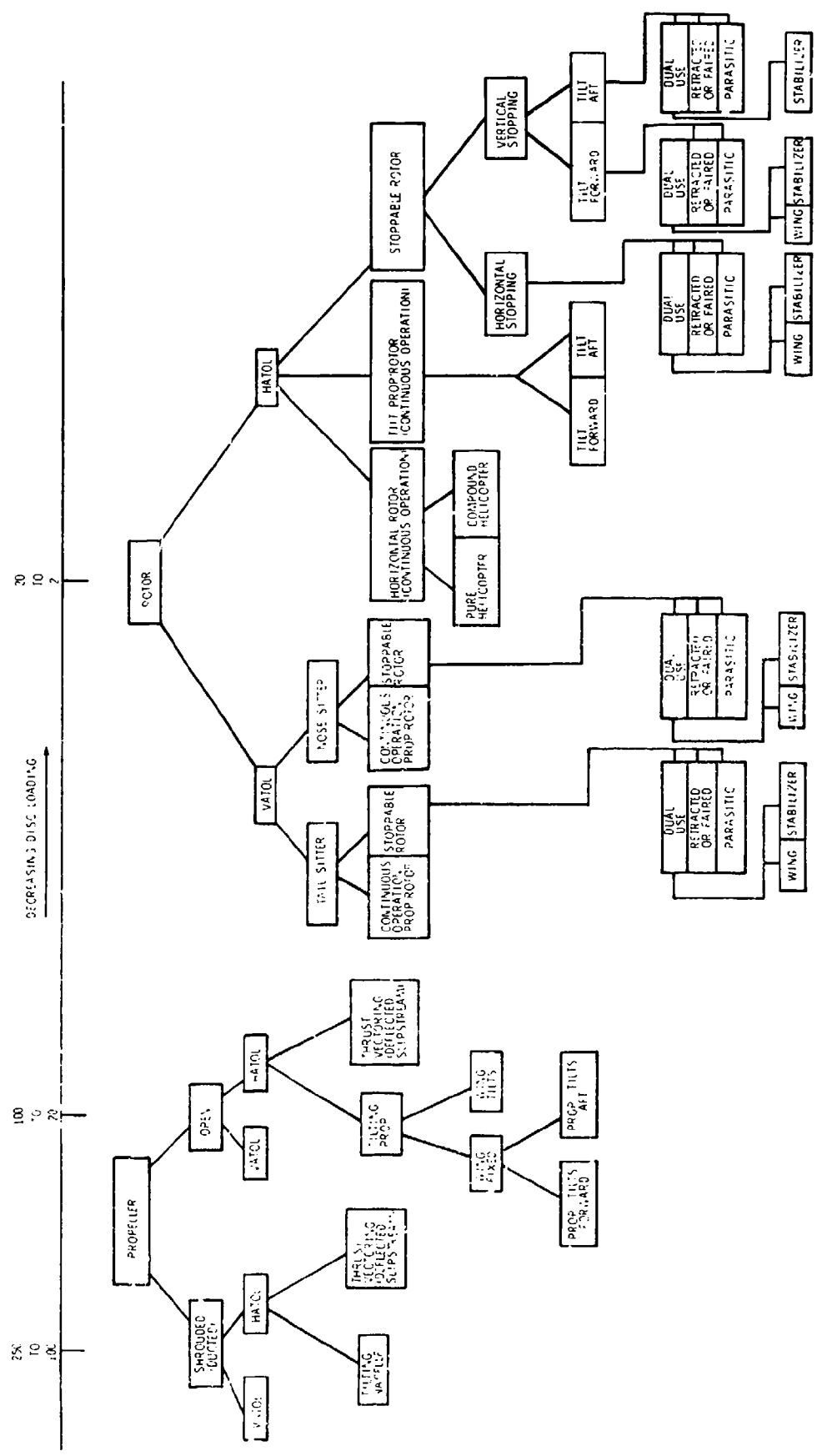

Figure 1.13 Major Categories of VTOL & V/STOL Vehicles - Propeller and Rotor Approaches

Many factors enter into a V/STOL concept selection; some of the most obvious are:

Operational flexibility	Transition and conversion behavior
Hover efficiency	STOL capability
High speed capability	Useful load-to-empty weight ratio
Cruise efficiency	Costs (development, production, operational)
Combat effectiveness	Maintainability
Downwash velocity & temperature	Reliability
Noise	Flight safety
Flight control characteristics	Human factors (e.g. pilot & passenger seating position)
Steep gradient descent capability	

While all of these, plus other factors, impact on concept selection and the implementing airplane designs, the propulsion system is the key element; it has an overriding influence on the airplane design and its characteristics.

"Disc loading" (defined as thrust divided by a representative area, e.g. propeller disc, shroud exit and jet nozzle areas) provides a rational basis for categorizing the various propulsion systems, for bringing out merits and drawbacks, and for making concept and design comparisons. Hence, this report is based on such a categorization, using a progression (Figures 1.12 and 1.13) that starts with the highest disc loading types (rocket thrusters) and ends with helicopter type rotors, the lowest disc loading devices. All of the known concept possibilities appear in Figures 1.12 and 1.13 under the primary propulsion system classifications of Rocket, Turbojet/Turbofan, Propeller, and Rotor. This Volume (I) presents those concepts which use Rocket and Turbojet/Turbofan propulsion (in wingless vehicles and VATOL type aircraft). Subsequent volumes will deal with propeller and rotor concepts.

Fundamentally, V/STOL propulsion systems are of two types: those which provide thrust only during vertical and low speed (sub-aerodynamic) flight and those which have the dual function of supplying vertical lift and cruise propulsion. These latter operate continuously in all powered flight modes. A third propulsion system is found in some V/STOL aircraft where the primary system is not used to aid vertical flight, being employed to provide thrust only in transition and conventional flight, as in conventional airplanes. In such V/STOL aircraft, all vertical lift is provided by separate propulsion devices. Figures 1.12 and 1.13 identify the possible propulsion combinations.

The rocket motor and turbojet engine, as basic force producers, deliver the required thrust with the least "disc area" (highest disc loading) and with the least rotor or engine weights, but use the largest amounts of fuel. Reduction in static thrust fuel consumption can be obtained by increasing

the effective disc area (and propulsion system weight) through the use of mass flow augmenters. These can be ejectors, fans, propellers or helicopter type rotors.

Table 1.2 gives information on some of the static thrust (hover) characteristics of the various propulsion systems. Merits and drawbacks are apparent in the downwash velocities and temperatures, hover fuel consumption and system weight. Obviously, other characteristics are significant also, such as noise, system complexity, reliability, cost, installed volume, transition flight behavior, etc. For the dual function propulsion systems, cruise efficiency is a troublesome factor of much concern.

Figure 1.14 shows the variation in power required for static thrust in terms of power loading and disc loading for the various propulsion systems. Power required is significant primarily because it is an index of the fuel needed during the vertical and very low speed flight modes. The powerful effect of disc loading is evident in Figure 1.15 and from Table 1.2; it is seen that the difference can be as much as 20 times between helicopter type rotors (0.001 lb fuel/lb thrust/min) and turbojets (0.020). Obviously, the propulsion system weight (installed) and aerodynamic interference effects must be considered, in addition to the system fuel consumption, to get a complete picture of the relative hover and low speed flight duration capabilities of the different propulsion approaches.

Propulsive efficiency and the resultant fuel consumption also are of interest in conventional mode forward flight (cruise). Here, the intended operating speed has an important influence on propulsion system selection. As with conventional airplanes, it is evident that turbojet and low bypass ratio (BPR) turbofan engines are best for transonic and supersonic flight, while the lower disc loading systems are more suitable for the subsonic regime. However, all of the propulsion systems generally are compromised when they are used to provide thrust in vertical flight. For example, use of only lift-cruise engines for thrust in all flight modes leads to oversized engines for cruise resulting in high fuel consumption.

Regarding the vehicle categories of Figure 1.12, it should be noted that there are vehicles which fly without using aerodynamic lift; these are classed as wingless. Generally, these use rocket propulsion (e.g. Rocket "Pogostick", Figure 2.2.2.3) or an airbreathing jet engine (e.g. Williams WASP I, Figure 3.2.3.2.2), and fall into the lift/cruise (L/C) propulsion category. Considering the definition of VATOL (Vertical Attitude Take-Off and Landing) and HATOL (Horizontal Attitude Take-Off and Landing) the distinction between them is that the longitudinal axis of the VATOL's airframe is vertical during VTOL while that of the HATOL is horizontal. During transition, the VATOL machine tilts to an approximately horizontal atti-

TABLE 1.2  
 STATIC THRUST CHARACTERISTICS OF PROPULSION SYSTEMS

System	"Pisc Loading" (lb/sq ft)	Bypass Ratio	Pressure Ratio	Thrust to Weight	Efflux Velocity ft/sec	Efflux Temperature °f	lb Fuel/ lb Takeoff Thrust min
Rocket	25,000-40,000	0	--	25 to 60/1	5,000	2,000-2,500	0.17 to 0.25
Turbojet (see A/B)	1,000-2,000	0	2.0 to 2.5	6 to 10/1 <sup>1</sup> 10 to 20/1 <sup>2</sup>	2,000-2,800	1,600 to 1,800	0.01 to 0.02
Turbojet (with B/B)	1,500-3,000	0	3.0 to 3.8	5 to 8/1	3,000-4,000	3,500	0.02 to 0.04
Turbofan	500-1,000	1 to 6	1.1 to 2.0	5 to 9/1 <sup>1</sup> 2 to 12/1 <sup>2</sup>	1,500-1,800	1,000-1,500	0.006 to 0.01
Turbofan (with B/B)	1,000-2,000	1.0 to 2.0	1.7 to 3.0	5 to 8/1	2,000-3,000	3,500	0.025 to 0.05
High Fan	400-800	10 to 20	1.19 to 1.33	4 to 6/1	350-600	ambient to 140	0.005 to 0.008
High Fan	500-1,000	4 to 6	1.14 to 1.28	4 to 5/1	600-800	270	0.003 to 0.01
Low Fan	100-200	35 to 80	1.05 to 1.12	2 to 4/1	200-325	near ambient	0.003 to 0.004
Unshrouded Propeller	50-100	30 to 100	1.014 to 1.05	3.5 to 7/1	130-300	near ambient	0.002 to 0.003
Shrouded	100-200	200 to 900	1.001 to 1.014	7 to 10/1	40-130	ambient	0.001 to 0.002

<sup>1</sup> Disc loading is defined as the thrust divided by a representative area of the device; e.g., exit area of rocket or turbojet nozzle.  
<sup>2</sup> Includes engine, ducting, valves, shafting, gear boxes in addition to the fan or propeller.  
 Conventional engine types.  
 Lift engine types.

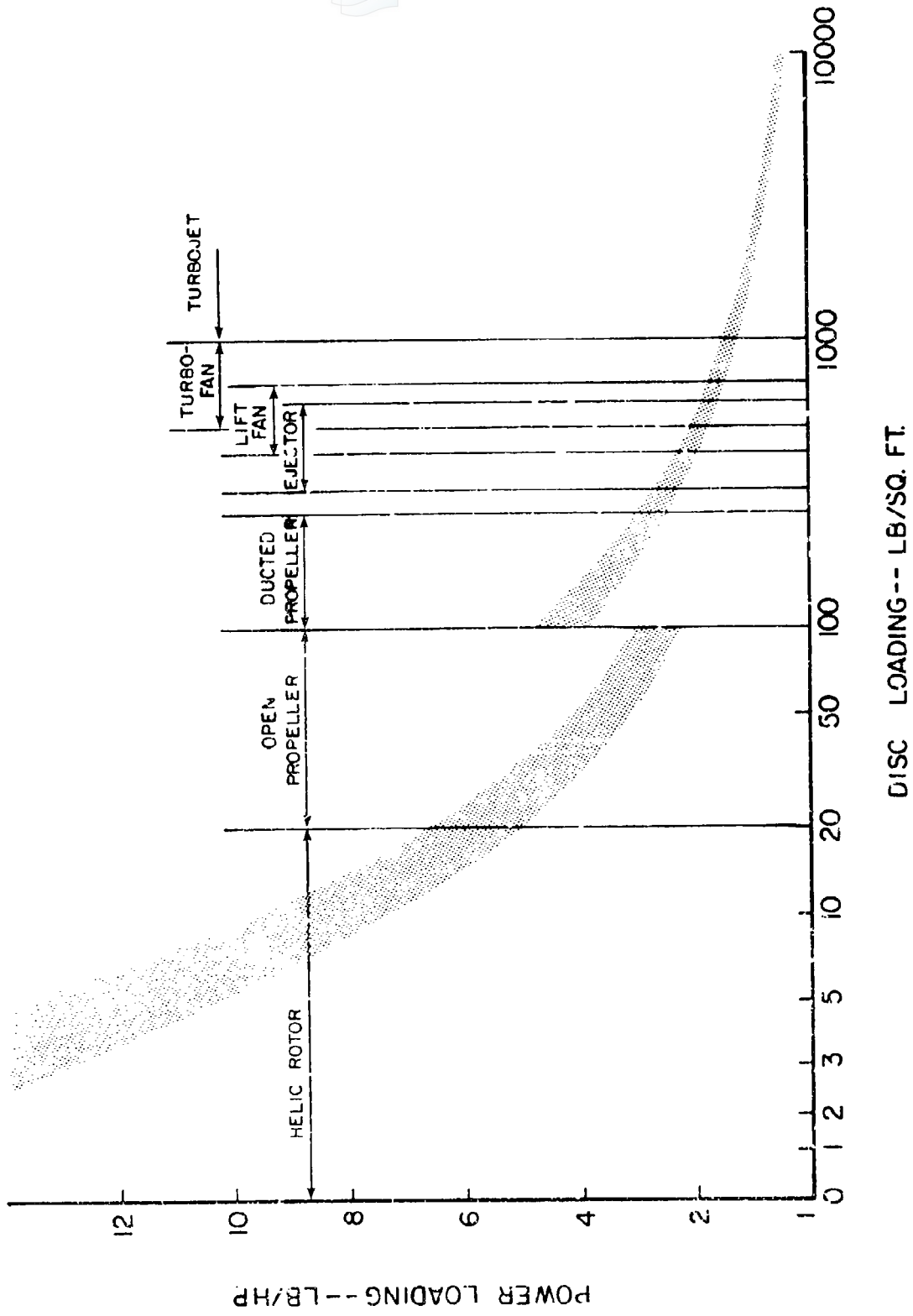

Figure 1.14 Power Required to Produce Static Thrust for Different Propulsion Systems

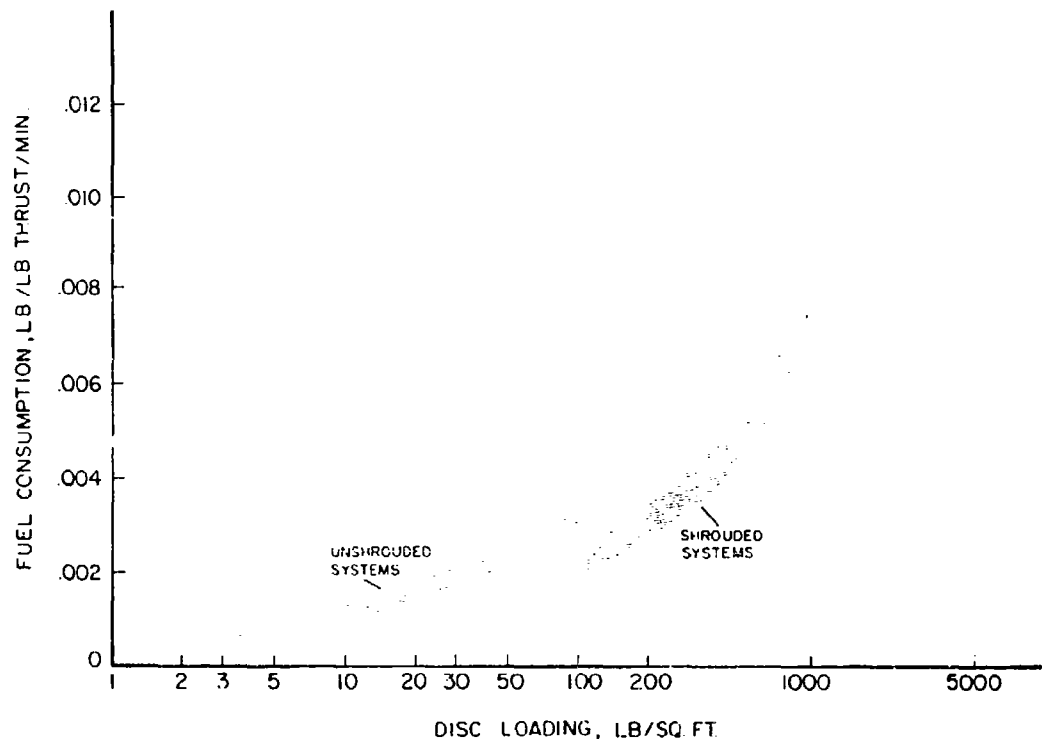

Figure 1.15 Static Thrust Specific Fuel Consumption vs. Disc Loading for Different Propulsion Systems

attitude in conventional mode flight; the fuselage of the HATOL remains essentially horizontal from vertical through transition flight.

Open (unshrouded) propellers may be competitive in propulsive efficiency with high disc-loaded shrouded systems even at speeds of about Mach 0.8; below this, the unshrouded type is generally superior. It is noteworthy that unpublished studies done by Hamilton Standard, Division United Technologies Corporation have indicated that it may be possible to build unshrouded propellers capable of flying up to 1.2 Mach while retaining quite good propulsive efficiency compared with turbofans.

A particular merit of the high bypass-ratio (BPR)<sup>1</sup> fans and propellers is their inherent increase in thrust with decreasing flight speed at constant power. This is the well-known lapse rate. Figure 1.16 shows the effect of BPR on static thrust amplification for a few propulsion systems designed to cruise at Mach 0.8. The higher the BPR, the higher is the available static thrust; but it may be difficult to take full advantage of this potential with very high BPR systems since there are performance compromise problems arising from design conflicts in blade area, tip speed and blade twist required for VTOL and for cruise flight. These conflicts must be resolved to obtain relatively efficient operation in both modes.

The rotor, which also operates as a propeller ("Prop-Rotor"), is basically a propeller of very high BPR with disc loadings (about 12 to 15 lb/sqft) between those of the conventional helicopter rotors and V/STOL type propeller. Theoretically, the prop-rotor is capable of operating at the same forward speeds as the conventional propeller with at least equal propulsive efficiencies. However, the prop-rotor has greater problems in such areas as structural dynamics and incorporation of proper blade twist to permit both good hover and cruise efficiencies. Depending upon the V/STOL airplane requirements used, e.g. cruise speed and hover endurance, there will be an optimum disc loading for propellers or prop-rotors (and also turbofans); the disc loading selected directly impacts on vehicle concept decisions, e.g., tilting vs. fixed wing.

It appears that advanced propellers, using current aerodynamic and structural technologies, could have relatively high propulsive efficiencies even at Mach 0.8. Figure 1.17 compares these new propellers with earlier types. The ideal thin blade is one which experiences no compressibility losses.

---

<sup>1</sup>By-Pass-Ratio (BPR) - Ratio of air mass flow (cold) through the engine by-pass duct to the air mass flow (hot) through the engine core.

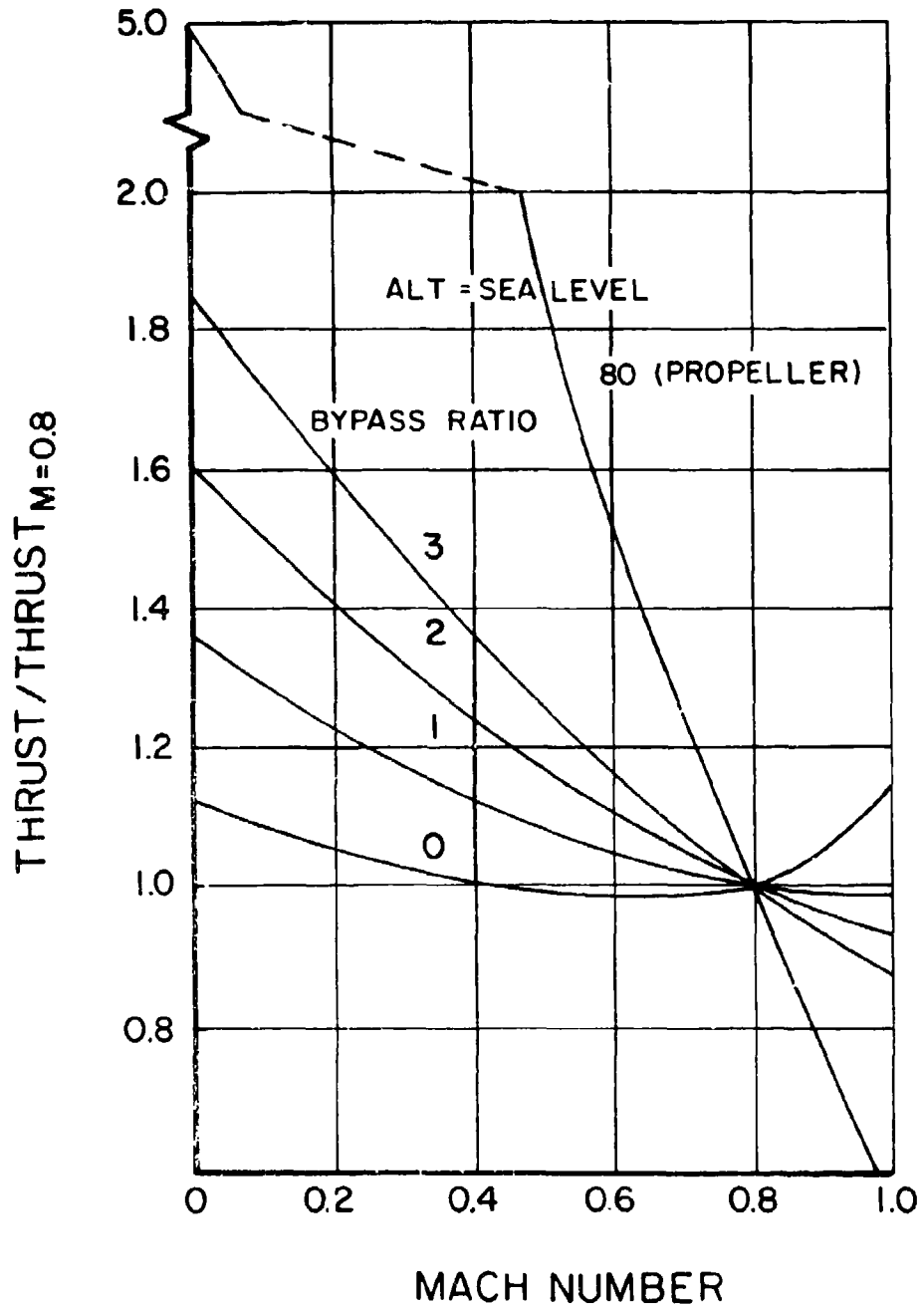

Figure 1.16 Thrust Versus Mach Number for Several Bypass Ratios (from Reference 1.3)

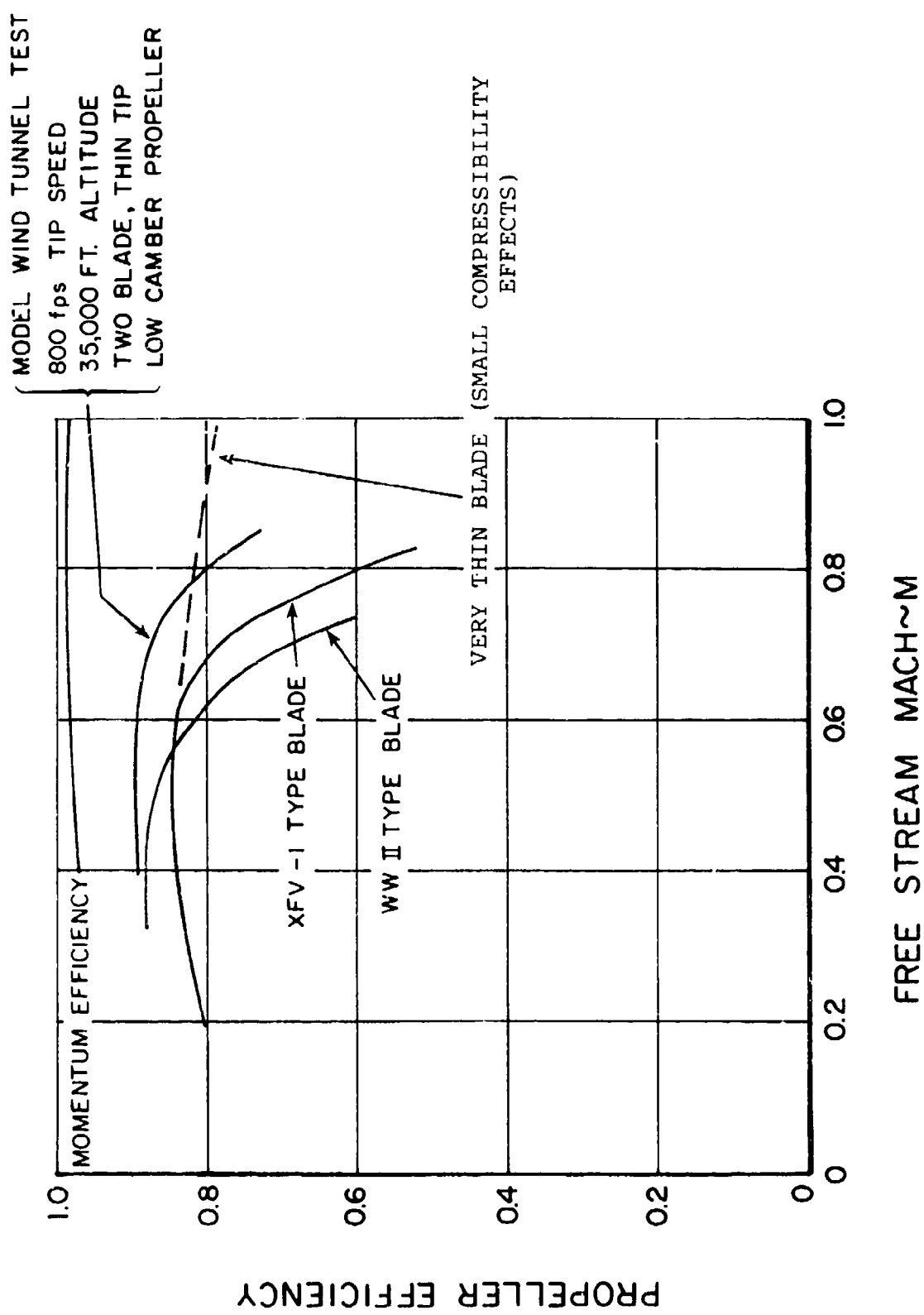

Figure 1.17 Propulsive Efficiency Envelopes of Propellers (from References 1.4 and 1.6)

Beyond these aforementioned propulsion system characteristics, there are a number of other outstanding considerations, three primary ones being downwash, noise and flight control. Downwash effects on the surface beneath the aircraft are complex, being influenced by the nature of the flow (swirl and vorticity) as well as velocity and temperature. Shown in Figure 1.18 are the minimum velocities which can be expected from the various propulsion systems under sea level standard day conditions.

Among the important factors affecting noise generation are disc loading, tip speed and jet exhaust velocity, with noise being reduced as these decrease. This is illustrated by Figures 1.19, 1.20 and 1.21. In general, for military aircraft, noise may not drive propulsion system selection, except when special requirements are introduced (e.g., "stealth" type operations). Low noise generation propulsion systems are critically important to civil V/STOL aircraft.

For satisfactory flight, the V/STOL airplane must have sufficient longitudinal, lateral, directional and vertical control in all flight modes to handle the six basic degrees of motion freedom including trim requirements. Some propulsion systems can provide such control in vertical and low speed flight with relatively little expenditure of energy or power because control is inherent in the system. Others use a substantial amount of engine power to produce the required moments and forces and, further, can introduce appreciable additional complexity into the aircraft. The helicopter rotor, with its high stored energy (inertia) and its cyclic and collective control of blade pitch, is an excellent example of the former type of lift system while the turbofan-powered Harrier is an example of the latter type.

Other possibly important vertical lift system capabilities are: vehicle behavior after loss of an engine or thruster, power-off landing capabilities (e.g. helicopter type autorotation), maneuver capability in both low and high speed flight, and lift system influence on STOL performance.

Vehicle behavior, after an engine loss during sub-aerodynamic flight, can be an important consideration in the selection of concepts and configurations. Two factors are involved: lift degradation and flight control. Lift loss due to an engine failure is determined by the number of engines and the actual lift generator used (e.g. rotors, propellers, fans or direct jet thrust). The lower disc loading lift generators suffer the least lift reduction upon loss of an engine in a multi-engine, interconnected system. Lift loss can cause a forced descent which, at worst, can result in a controlled

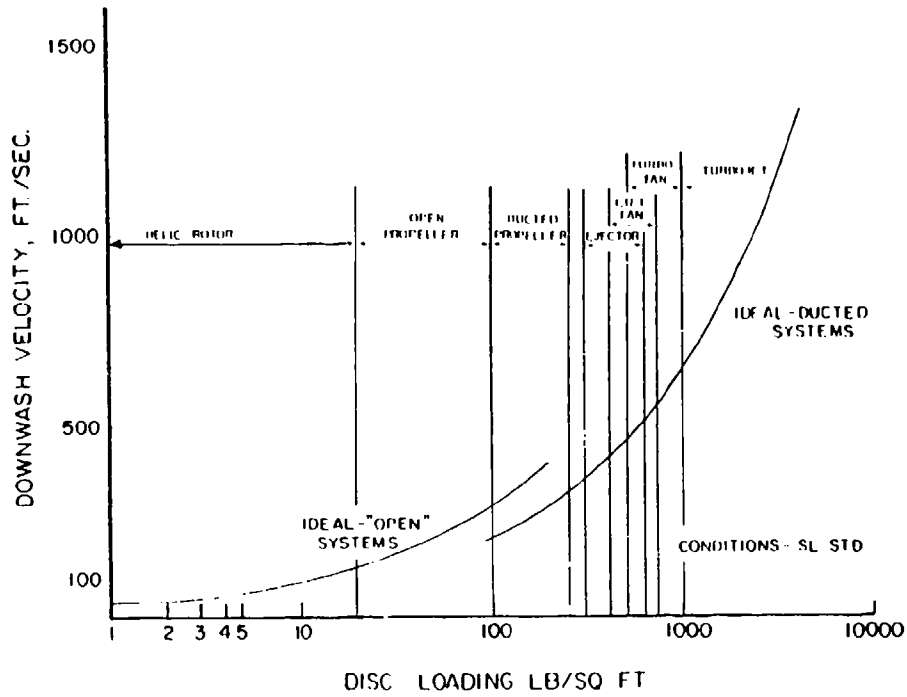

Figure 1.18 Downwash Velocity as a Function of Disc Loading

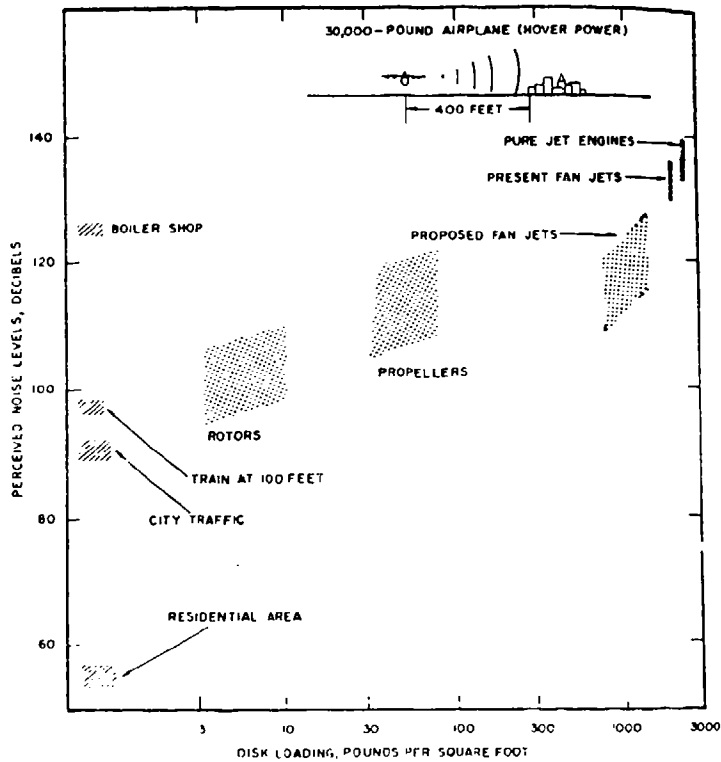

Figure 1.19 Effect of Disc Loading on Perceived Noise Levels (from Reference 1.2)

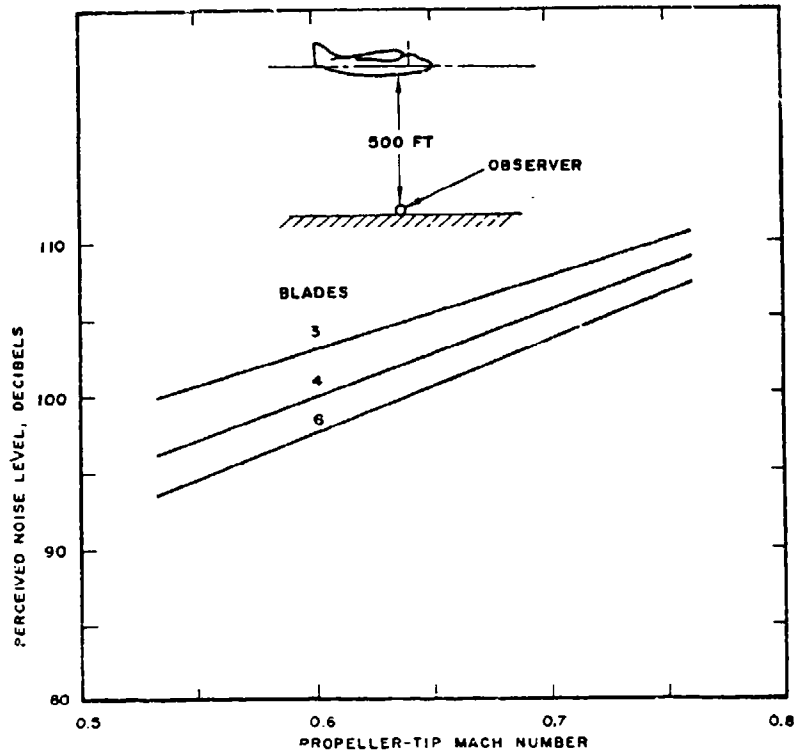

Figure 1.20 Turboprop Noise Levels as a Function of Propeller-Tip Mach Number and the Number of Blades (from Reference 1.2).

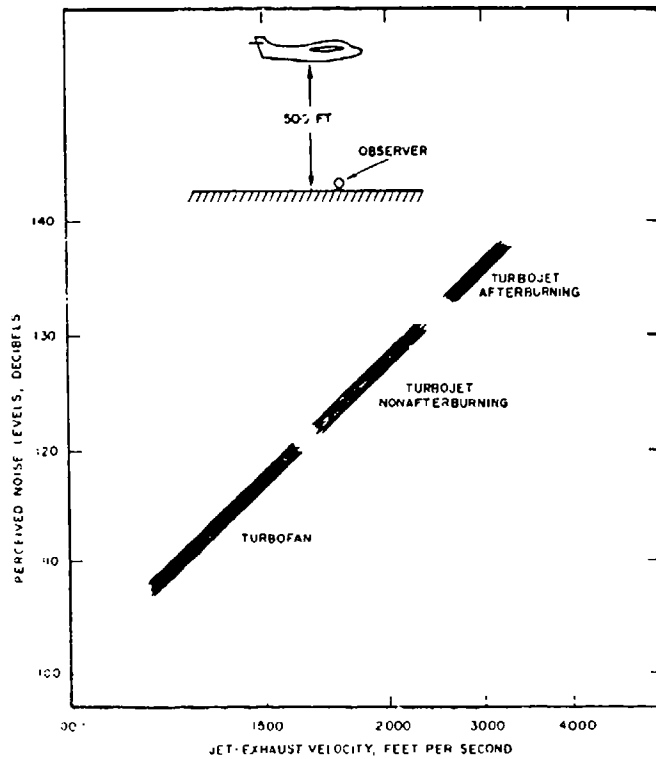

Figure 1.21 Exhaust Noise from Jet Engines as a Function of Jet Exhaust Velocity (from Reference 1.2).

crash landing if adequate control power is available. Possibly of more serious consequence is the inability to trim or control the vehicle after an engine failure since this can lead to an uncontrolled situation. It will be found that the various VTOL aircraft concepts and configurations can be categorized with respect to behavior after an engine loss. Some notable examples out of many are: the Soviet YAK-36 which will lose a substantial amount of lift and become longitudinally uncontrollable necessitating pilot ejection upon an engine failure; the single engine Harrier which loses all vertical lift and control; the Mirage III V which loses only a small amount of lift and retains control; and the propeller driven XC-142 which retains a large percentage of lift and has adequate control after an engine is shut down. The decision regarding design to provide lift and control after an engine failure will be influenced by the operations required of the aircraft (fighter, transport, etc.) and by the impact of the design features on such factors as airplane complexity, weight, performance and cost. A VTOL fighter which loses lift and control after an engine failure during VTOL still may be the optimum airplane from a total system standpoint.

In this report, the presentation approach taken is to group together those designs and developed aircraft having similar basic conceptual philosophies rather than following a strictly chronological order. It is hoped that this will provide a more meaningful review of the past V/STOL efforts.

REFERENCES - SECTION 1

- 1.1 Eugene K. Liberatore, "Convertible Aircraft," Vol. 13 of Rotary Wing Aircraft Handbooks and History, Prewitt Aircraft Co., 1954.
- 1.2 "Report-Beyond the Horizon, Flight in the Atmosphere, 1975-1985, Vol. III, Vertical Takeoff and Landing," USAF, AFSC Task Force, Jan. 1967.
- 1.3 "Vertical Take-Off and Landing Concepts Applicable to Drones/RPVS," USAF RPV Mission Analysis Study, 1973-1974, Appendix G-11.
- 1.4 C. Rohrback and F. B. Metzger, "The Prop-Fan, A New Look in Propulsors," AIAA Paper No. 75-1208, AIAA/SAE 11th Propulsion Conference, Sept. 29-Oct. 1, 1975.
- 1.5 F. C. Swanborough, "Vertical Flight Aircraft of the World," Aero Publishers, U.S.A., 1964.
- 1.6 "VTOL Strike RPV Study," Lockheed-California Co., LR-26175, Contract No. F33657-74-C-0190, Dec. 12, 1973.
- 1.7 "Proposal for Construction of Heliplane, Model XGEH-1C," General Electric Company Proposition No. G.O. 20438 (proposal prepared by York Research Corporation), Feb. 8, 1944.

## SECTION 2

### ROCKET BASED VTOL VEHICLES

#### 2.1 INTRODUCTION

The term "vehicles" instead of aircraft is used in the title of this section because rocket propulsion systems can operate without need for an air environment. The best known rocket powered VTO vehicles are the Intercontinental Ballistic Missiles, space vehicle launch boosters and the Lunar Module. Of these, only the Lunar Module (Figure 2.1.1) was designed for both vertical take-off and landing. All of these rocket systems fall into the direct (un-augmented) thrust category of Figure 2.1.2. When operating in the Earth's atmosphere, rocket propulsion systems can take advantage of the surrounding air mass through use of augmenters to increase their thrust and reduce specific fuel consumption.

Since the unaugmented rocket system does not require an air environment for thrust, it is suitable for extraterrestrial use. Bell Aerospace, expanding on their successful development of their Rocket Belt system (Figure 2.2.2.1) performed studies for NASA on a Lunar Flying Vehicle (LFV) in 1964 and on a Manned Flying System (MFS) in 1965 illustrated in Figures 2.1.3 and 2.1.4 and flew a two-man platform (Figure 2.2.2.4) in 1967.

While the technology base for rocket propulsion systems is very well developed, including flight control through thrust vectoring, and such systems could be readily incorporated into V/STOL aircraft, relatively little has been done in this direction. Generally, the propellants considered for use create logistic, safety and operational cost problems. Further, the very high specific fuel consumption seriously limits thrust-borne flight time, seriously reducing operational flexibility when compared with air breathing propulsion systems. But rocket motors and their ancillary equipment are relatively simple systems and they deliver the highest thrust-to-dry weight of any propulsion system. Hence, they have found operational use in airplane assisted take off (RATO) and zero length launch of remotely piloted vehicles and missiles.

An example of a vertical take off airplane solely using rocket propulsion for flight was the German Bachem Ba 349 "Natter" (Reference 2.1) developed near the end of World War II (Figure 2.1.5). This was an expendable, manned, rocket-powered interceptor designed to attack enemy bomber formations. Although fitting into the VATOL classification in Figure 2.1.2, it was not really a VTOL aircraft in the normally accepted

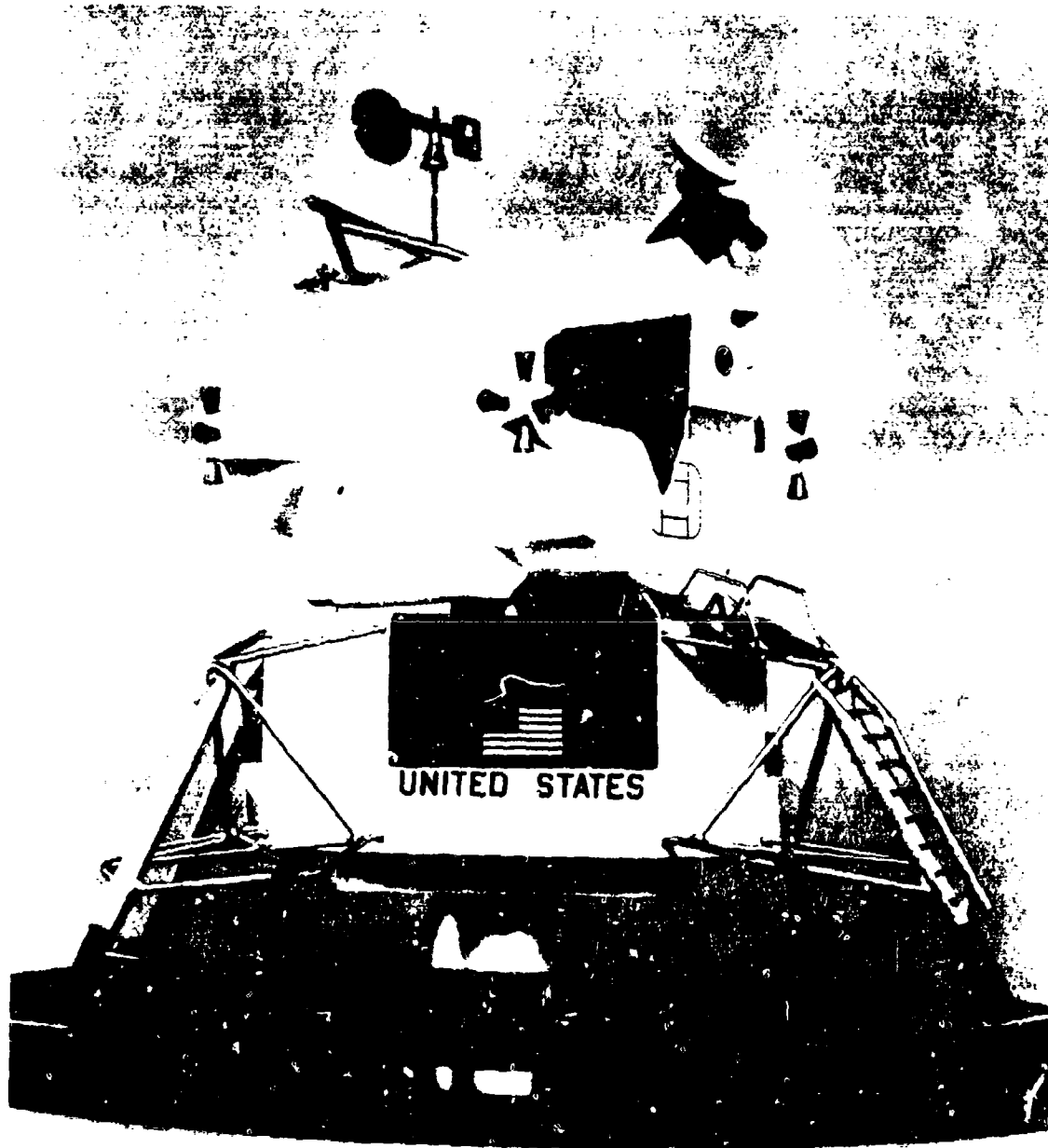

Figure 2.1.1 Lunar Module

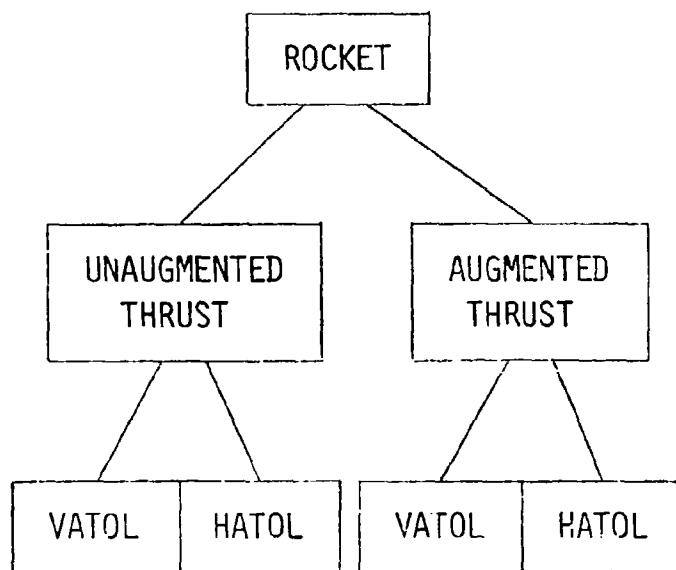

Figure 2.1.2 Categories of Rocket-Powered Vehicles

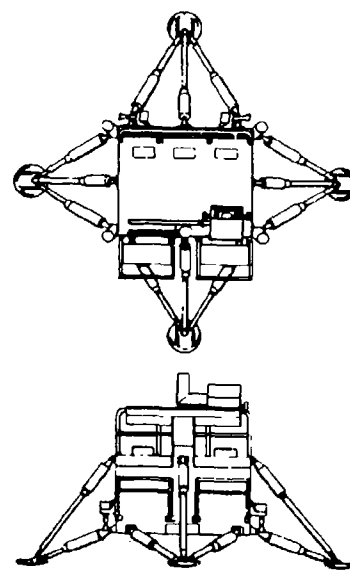

Figure 2.1.3 Bell Aerosystems Lunar Flight Vehicle (LFV)

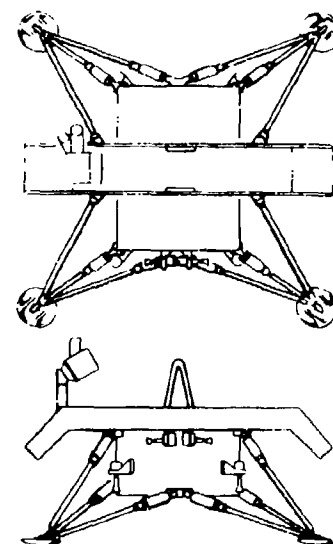
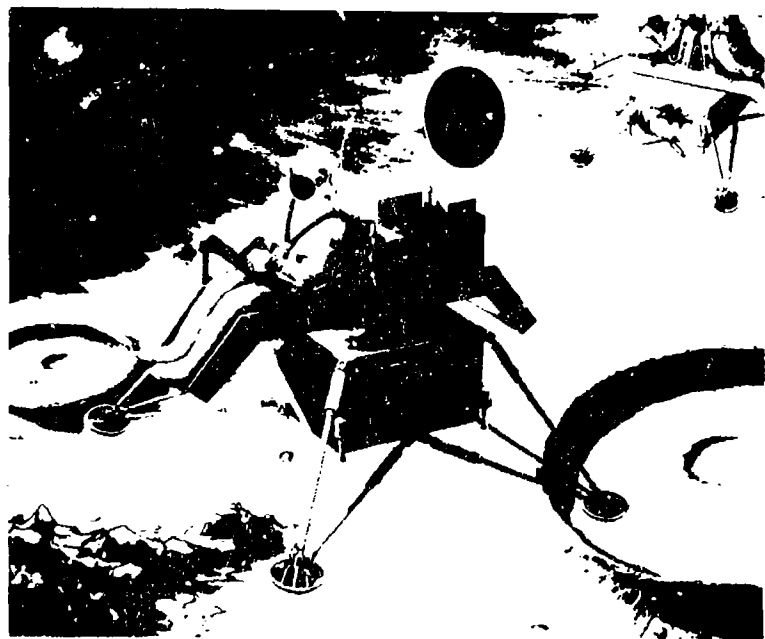

Figure 2.1.4 Bell Aerosystems Manned Flying System (MFS)



Figure 2.1.5 German World War II Bachem BA-349B "Natter" VTO Interceptor  
(Courtesy of BPC Publishing Ltd., London, England)

sense because it was designed for vertical take-off on rails (Figure 2.1.6) but not for hovering or vertical landing. The VTO was used primarily to eliminate conventional take-off operations. The airplane was arranged to disassemble in the air after attacking the enemy bombers; parachutes were used to recover the pilot, instruments and aft fuselage containing the control system and rocket motors.

A large variety of propellants are available for rocket propulsion and these can be of the bipropellant (fuel plus oxidizer) or monopropellant type where decomposition is used to provide heat and pressure. Further, the bipropellants can be either of solid or liquid type. Selection of the propellant usually is based upon such factors as: cost, safety, toxicity, handling problems, specific impulse (determines amount of propellant required), heat generated (affects rocket motor design), storage characteristics, etc. To date, nearly all of the VTOL vehicles studied or built have been based on a liquid monopropellant with the preference being for hydrogen peroxide ( $H_2O_2$ ). This is a relatively safe, easy to handle material, generating moderate temperature ( $1300^\circ F$ ) and giving off no toxic or corrosive emissions. Its cost is about 50 cents/lb for 90% concentration (in 1980), when obtained in large quantities.

Despite the negative aspects of rocket propulsion, several studies and developments based on such propulsion have been carried out. These are listed in Table 2.1.1. The important characteristics of the unaugmented and augmented thrust rocket-powered vehicles are given in Table 2.1.2 and the following paragraphs discuss these vehicles (the Lunar Excursion Vehicles are not included). Although the Martin "Super Fan" VTOL airplane M-380-2 (Figure 2.3.1.3) and the helicopters may not be considered to be true members of the rocket powered VTOL vehicle family, these are shown because they are good examples of rocket propulsion thrust augmentation systems which use rotors.

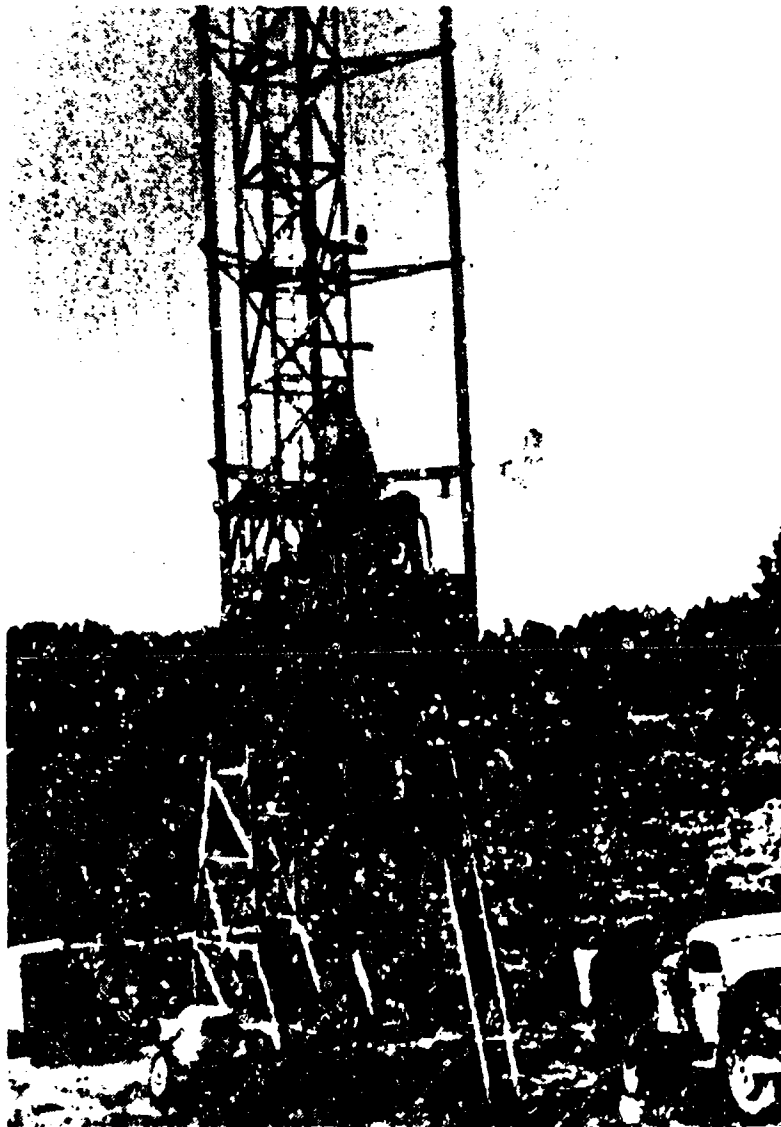

Figure 2.1 6 Bacher BA-349B Rocket Airplane  
Mounted on VTO Apparatus

**TABLE 2.1.1**  
**ROCKET-POWERED VTOL VEHICLE PROJECTS**

Company & Vehicle	Vehicle Mission	Purpose of Effort	Sponsor	Time Period of Effort	U.S. Gov't Contract No.	U.S. Gov't Funding, \$	Remarks
<b>UNASSIGNED ROCKET CONCEPTS</b>							
1. Pachen Werke GmbH Ba 349 A80, "Mistral" V10 Aircraft	Bomber interceptor	Develop & produce low cost interceptor	German Air Force (Luftwaffe)	1944	none	zero	36 built for test and evaluation. War ended before production started.
2. Bell Aerospace (formerly Bell Systems) "Rocket Belt"	Individual flight (mobility)	In-house concept exploration	Company	1957	none	zero	Tethered flights made.
3. Thinkol Reaction Motors Inc. (Bell "Jump Rocket")	Improved ground mobility for individuals	In-house concept exploration	Company	1958-1959	none	zero	Jump capability and high speed running demonstrated
4. Aerojet Systems Division of Aerojet General, Army Small Rocket Lift Device (SRLD)	Individual flight (mobility)	Study feasibility of SRLD	U.S. Army TRECOCM	June 1958- July 1960	DA44-177-TC-595	56,456	No hardware built under the contract.
5. Bell Aerospace "Rocket Belt" (Army Small Rocket Lift Device-SRLD)	Individual flight (mobility)	SRLD Flight demonstration	U.S. Army TRECOCM	Aug. 1960- May 1961	NA	50,000 (Approx)	Very successful program. Over 3,000 flights made without a malfunction.
6. Bell Aerospace One Man "Popostick"	Individual flight (mobility)	Explore jet lifted platform concept	Company	1963-1964	none	zero	Flown successfully. Also used to demonstrate kinesthetic control.
7. Bell Aerospace Flying Chair	Individual flight (mobility)	Explore jet lifted platform concept	Company	1963-1964	none	zero	Flown successfully.
8. Bell Aerospace Two Man "Popostick"	Individual flight (mobility)	Explore jet lifted platform concept	Company	1963-1964	none	zero	Flown successfully.
9. Bell Aerospace Lunar Flying Vehicle	Lunar transportation	Design study for NASA	NASA	1968	NA	250,000	No vehicle built.

NA - Not Available.

TABLE 2.1.1 (Cont'd)

<u>Company &amp; Vehicle</u>	<u>Vehicle Mission</u>	<u>Purpose of Effort</u>	<u>Sponsor</u>	<u>Time Period of Effort</u>	<u>U. S. Gov't. Contract No.</u>	<u>U. S. Gov't. Funding, \$</u>	<u>Remarks</u>
<b>AUGMENTED THRUST CONCEPTS</b>							
1. The Martin Company "Superfan" concept	Combat surveillance	Design Study of V/STOL aircraft	Company	1959-1960	none	zero	The "superfan" concept was to be used as a means for increasing the vertical lift of a tilt-wing V/STOL airplane.
2. Sud Aviation "Ludon"	Individual mobility	Development of vehicle prototype	French Army	1965-1968	none	zero	Used ejector system to augment rocket thrust but flight durations still too low for operational use. Flight Control system satisfactory.
3. Kellett Aircraft KH-15 "Stable Mable"	Helicopter stability research	Build a simple helicopter for rotor stabilization system research	U.S. Navy Office of Naval Research	1953-1954	NOMR-1563(00) NOMR-1222(00)	300,000*	Rotor driven by hydrogen peroxide rocket motors mounted at rotor blade tips. Vehicle flew well. Used to demonstrate mechanical stabilization system on rotor.
4. Aerospace General "Mini-copter" Helicopter	Individual mobility	Development and flight-test of prototype	U.S. Navy Naval Air Development Center & Naval Air Systems Command	1968-1974	NOMR-10300 NOA553-903C	245,000	Rotor driven by hydrogen peroxide rocket motors at rotor blade tips. Vehicle flew well.

\*Estimated

TABLE 2.1.2  
DEVELOPED ROCKET-POWERED INDIVIDUAL LIFT DEVICES

Device	Bell Rocket Belt	Bell One-Man Pogo	Bell Two-Man Pogo	Sud-Aviation Ludion	Aerojet-General "Mini-copter" <sup>4</sup>
Thrust Augmentation Ratio <sup>1</sup>	1.0	1.0	1.0	1.5 <sup>3</sup>	21
Takeoff Wt, lb	270	up to 300 lb	up to 600 lb	440	600 <sup>5</sup>
Empty Weight, lbs	63	80	147	110 (estimated)	165
Pilot + Payload, lb	160	160	320	242	273
Pilot Payload	(160) (0)	(160) (0)	(160) (160)	(176) (66)	(180) (93)
Fuel, Wt, lb	47	30	60	88 (estimated)	162 (14 gal)
Range, ft	870	780	780	1925	11 miles (approx.)
Speed, mph	60+	60+	60+	60+	60+
Endurance, sec	21	21	21	30	658 (11 min)
Type of Fuel	90% H <sub>2</sub> O <sub>2</sub>	90% H <sub>2</sub> O <sub>2</sub>	90% H <sub>2</sub> O <sub>2</sub>	Isopropyl-Nitrate	90% H <sub>2</sub> O <sub>2</sub>
Propellant Spec. Impulse	122 <sup>6</sup>	122	122	N.A.	122
Maximum Available Total Rocket Thrust (unaugmented), lb	300	300	600	N.A.	up to 84

<sup>1</sup>Thrust Augmentation Ratio = Total Thrust/Thrust of Primary Propulsion Device.  
<sup>2</sup>Bell Rocket Belt not designed to carry any payload; with 160 lb pilot take-off excess thrust available was 30 lb.  
<sup>3</sup>Original design value; achieved value is not known.  
<sup>4</sup>"Mini-Copter" was capable of flying with greater weights than those listed; values listed are design values.  
<sup>5</sup>About 30 lb total rocket thrust required with 500 lb gross weight.  
<sup>6</sup>Calculated from data in table and assuming 10% reserve on fuel. Fuel available for 21 sec flight is 42.3 lb.  
 NA - Not Available

## 2.2 DIRECT (UNAugmented) Rocket Thrust Vehicles

### 2.2.1 U.S. Army Small Rocket Lift Device (SRLD) Program (1957-1961)

Up to the present (1980) primary use of rocket propulsion in VTOL vehicles has been in the individual mobility field, that is in "flying belt" or "flying platform" devices. Impetus to the flying belt concept came from a Col. Charles Parkin of the U.S. Army's Transportation Research and Development Command (TRECOC) as a result of his personal interest in the idea of using rocket thrust to improve an infantryman's physical capabilities, e.g. jumping and running. Col. Parkin had done some preliminary experiments in 1957 using compressed nitrogen (from a bottle strapped to his back) to establish the fact that, even with the very short thrust pulse available, he was consistently able to jump higher than without the apparatus. Late in 1957 industry was informed of the Army's interest in the "Jump Belt" concept as a means for increasing the foot soldier's mobility. This approach was named the "Grasshopper Concept" by the Army. The concept aroused the interest of three companies with rocket system background: Bell Aerosystems, Thiokol Corporation's Reaction Motors Division and Aerojet-General's Aerojet Systems Division, leading the latter two to undertake company-funded exploratory work. Bell Aerosystems had actually become interested in the Rocket Belt concept spontaneously in 1957. In 1959 TRECOC issued a formal Request for Proposal (RFP TC-44-177-59-Neg.-72) to industry for a study to determine the feasibility of applying Small Rocket Lift Devices (SRLD) to increase the mobility of an individual soldier.

Responses were made by the three companies and, in July 1959, a contract (DA-44-177-TC-595) for Phase I was let to Aerojet-General to study the possible systems and define the optimum one.

In their exploratory work preceding the Army's Request for Proposal, both Thiokol RMD and Aerojet-General directed their initial efforts toward unaugmented, short duration (several seconds) rocket systems aimed at satisfying the Army's definition of mobility. At that time the Army was looking for a means to give an individual soldier the capability to run at high speed, perform long leaps down, up or across large obstacles and even to skim over a water surface at high speed.

Bell Aerosystems, on the other hand, concentrated their company-funded effort on using the unaugmented thrust Rocket Belt to provide free flight with as much duration as feasible. The company-sponsored work by all three companies was generally similar but each appears to have been unaware of the others' activities.

Following Aerojet-General's completion of the Phase I study and issuance of their report (Reference 2.2) defining the preferred Rocket Belt system, the Army selected Bell Aerosystems from among the three companies, the bidders for Phase II, to design, build and demonstrate the SRLD. This was done very successfully and Bell became the sole U.S. company engaged in the development of this type of individual mobility device. Subsequently, during the mid-1960's, Sud Aviation in France undertook for the French Army the development of a one-man, augments-equipmented rocket-powered vehicle (Figure 2.3.2.3).

Despite the success of the Rocket Belt, its limited, 21-second flight duration led Bell Aerosystems to the Jet Belt, replacing the rocket system with a turbofan engine. Since the termination of Sud Aviation's effort in 1969 there have been no further known efforts to use rocket propulsion for VTOL, other than Aerospace General's one-man helicopter (Figure 2.3.1.1). Individual mobility, using some form of small VTOL device, continues to be of interest and the various propulsion systems (rocket, turbojet/turbofan, lifting rotor) have all been explored.

Basically, individual lift devices take two forms: those which are strapped on (worn) by the individual and those which are rudimentary, small vehicles on which the person stands or sits. Rocket propulsion and, also, other VTOL propulsion systems (turbojet/turbofan and lifting rotor) have been applied to both the strap-on and small vehicle type devices. The latter has also been expanded into multiplace transport devices. The operational use of the individual lift systems creates an important distinction between them in terms of required operating time, size, complexity, pilot skill required, flexibility of use and cost.

In the following, the developments done by Bell Aerosystems, Aerojet-General and Thiokol are reviewed, with the reviews being kept brief for the latter two companies since their efforts did not result in true flight demonstration devices.

#### 2.2.2 Bell Aerosystems "Rocket Belt" and Rocket "Pogostick" Developments (1957-1962)

Bell Aerosystems Co. (now Bell Aerospace) in a well-planned and executed effort, successfully developed the world's first rocket-propelled and, later, jet engine-propelled VTOL individual lift devices. The key man behind this effort was Wendell F. Moore, later to become the company's Assistant Chief Engineer. Moore actually conceived the idea in 1953 but did not apply for a patent until June 10, 1960. The patent (No. 3,021,095), from which Figure 2.2.2.1 is taken, was

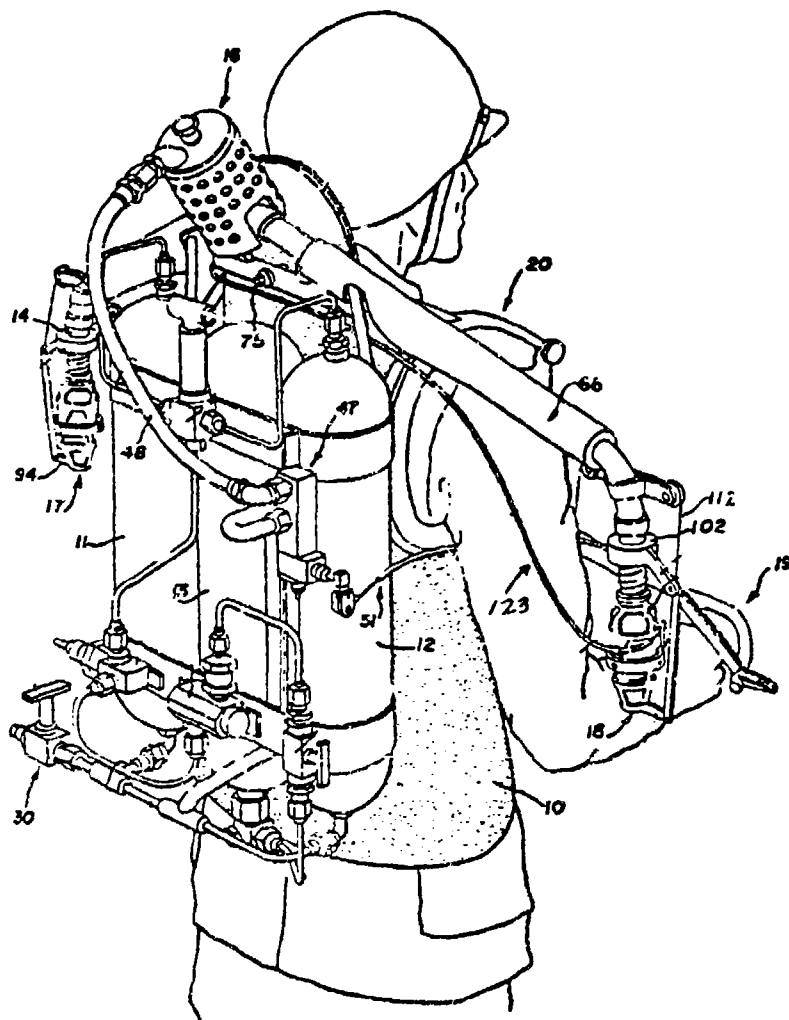

- |       |                           |     |  |
|-------|---------------------------|-----|--|
| 10    | Harness                   | 47  | Throttle Valve Assembly                    |
| 11,12 | Propellant Supply Tanks   | 48  | Flexible Connector Tube                    |
| 13    | Pressurizing Gas Tank     | 51  | Throttle Control Cable                     |
| 14    | Hot Gas Tube              | 66  | Heat Insulation                            |
| 16    | Gas Generator             | 75  | Pivot                                      |
| 17,18 | Hot Gas Tube Nozzles      | 94  | Lateral Deflection Lugs                    |
| 19    | Throttle Control Assembly | 102 | Stability Weights                          |
| 20    | Shoulder Engaging Ring    | 112 | Nozzle Deflection Cable                    |
| 30    | Filling Valve Assembly    | 123 | Bowden Cable for Fore-Aft<br>Nozzle Motion |

Figure 2.2.2.1 Important Elements of the Bell Aerosystems  
Rocket Belt (from Patent 3,021,095)

granted on February 13, 1962. Depicted on the figure are important elements of the Rocket Belt.

Bell Aerosystems started company-sponsored exploratory work on the concept, under Moore's direction, in 1957 after becoming aware of the U.S. Army's (TRECUM) interest in individual aerial mobility. A tethered system was used with pressurized nitrogen gas as the rocket propellant during the initial efforts (Figure 2.2.2.2).

In 1958 Bell Aerosystems responded to the Army's Request for Proposal for a Small Rocket Lift Device (SRLD) study (Phase I). After the contract award to Aerojet-General in 1958, Bell discontinued their company-sponsored work. However, when the Army issued the Request for Proposal in 1960 for Phase II, Construction, Flight Testing and Demonstration of a SRLD, Bell Aerosystems' interest was rekindled. They were selected over their competitors, Aerojet-General and Thiokol and received a contract in August 1960.

During the following four months a Rocket Belt apparatus was developed under Moore's technical direction and on December 29, 1960, the first tethered flight was made by Moore himself. Hydrogen peroxide was used as the propellant, having been determined to be the most desirable fuel during Aerojet-General's Phase I study. In the early stages of the development, cooperation took place between Bell and Aerojet-General; all later work was done solely by Bell.

After a test period covering 56 tethered flights and consequent modifications to the device, the first fully-free flight was performed on April 20, 1961 by Harold Graham, one of Bell's rocket test engineers. Historically, this was the first free flight ever made by a human using direct rocket thrust applied to the body. The flight lasted 13 seconds and covered 112 feet. Thiokol had demonstrated 3 to 5 second, 30 foot jumps during 1958, using nitrogen gas rocket propulsion but these are not considered to be free flights; they did not establish the capability of controlled, sustained human flight with the system.

With the subsequent demonstration of the SRLD by Bell, the contract was completed and terminated in May 1961. The company continued the Rocket Belt development effort on their own and between 1961 and 1966 more than 3000 flights were made by several pilots using five Rocket Belts. Significantly, the  $H_2O_2$  system was found to be 100% reliable. Under a contract from NASA to investigate the feasibility of lunar transportation devices, the Rocket Belt developed into the Rocket "Pogostick" and seat vehicles (Figures 2.2.2.3, 2.2.2.4 and 2.2.2.5). The success of the Rocket Belt and the desire for greater flight duration and range led to the development of the Jet Belt, covered in Section 3 of this document.

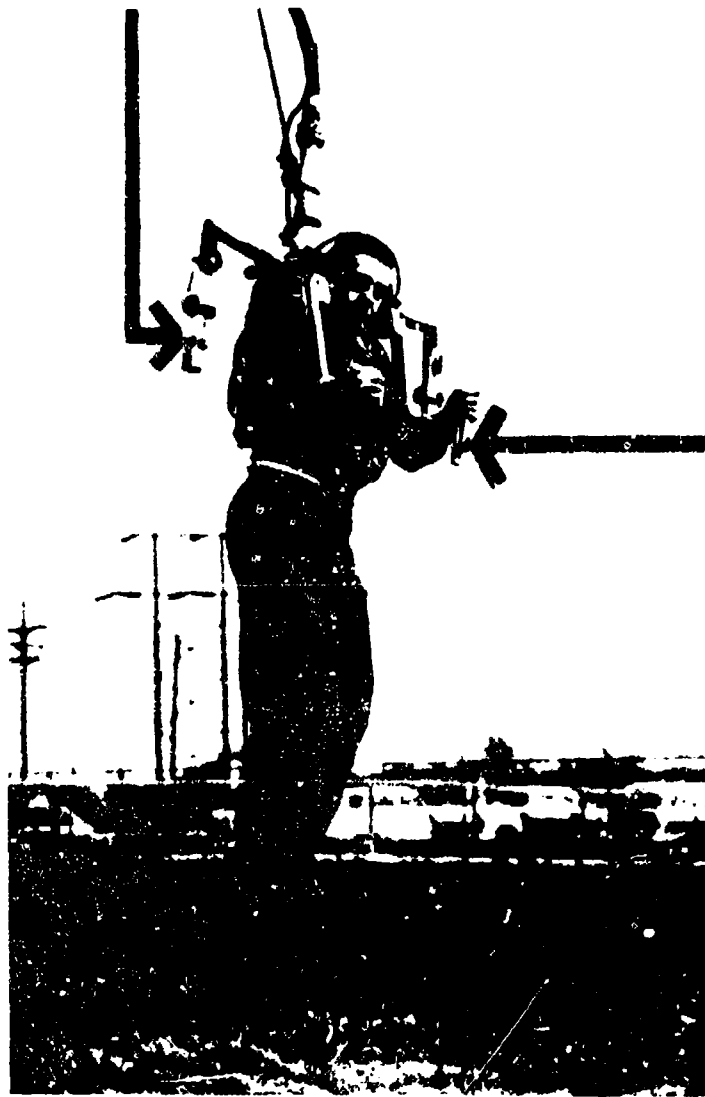

Figure 2.2.2.2 Bell Aerosystems Nitrogen-Powered Rocket  
Lift Device Tethered Flight Test Rig  
(Courtesy Bell Aerosystems Co.)

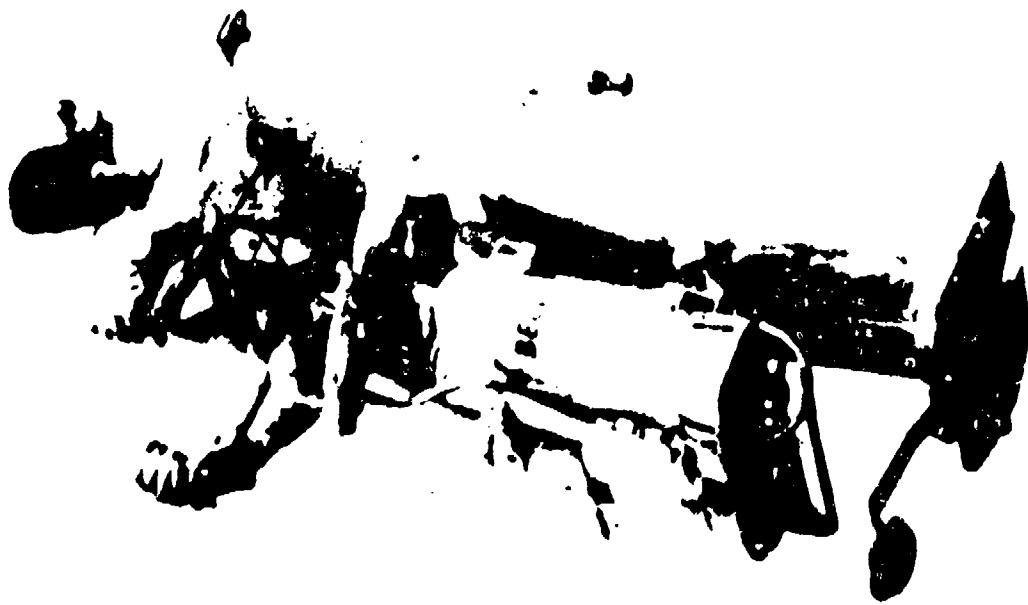

Figure 2.2.2.3 Bell Aerosystems One Man  
Rocket Powered Pogostick



Figure 2.2.2.4 Bell Aerosystems Two Man  
Rocket Powered Pogostick

(Figures courtesy of Bell Aerosystems Co.)



Figure 2.2.2.5 Bell One-Man Rocket Powered Flying Seat  
(Courtesy of Bell Aerosystems Co.)

A chronology of Bell Aerosystems' Rocket Belt and Pogostick developments follows.

TABLE 2.2.2.1

CHRONOLOGY OF BELL AEROSYSTEMS ROCKET BELT DEVELOPMENT

1953 Rocket Belt idea conceived by Wendell F. Moore of Bell Aerosystems

1957 Army (TRECUM) contacted industry for ideas to improve infantryman's mobility  
Bell Aerosystems initiated company-sponsored exploration of Rocket Belt concept using high pressure nitrogen-gas test rig  
First tethered flight made in nitrogen-gas test rig (Dec. 17)

1958 TRECUM RFP issued for Phase I study of SRLD  
TRECUM contract for study (Phase I of SRLD program) given to Aerospace-General Corporation (Contract No. DA44-177-TC-595, July 1958, \$56,456)

1959 Aerospace-General contract completed

1960 TRECUM RFP issued for Phase II, Fabrication, Test and Demonstration of SRLD  
Rocket Belt patent application made by Wendell F. Moore (June 10)  
Army contract for Phase II of the SRLD program awarded to Bell Aerosystems (Aug.)  
Bell Aerosystems first tethered test of SRLD (Dec. 29)

1961 Rocket driven fan system proposed by John K. Hulbert of Bell Aerosystems to increase Rocket Belt duration (Feb. 14)  
First free flight of SRLD; 13 seconds, 112 ft (Apr. 20)  
Project completed for Army, contract terminated (May)  
First public demonstration at TRECUM, Ft. Eustis, Virginia (June 8)  
Start of activity on Jet Flying Belt

1962 Patent 3,021,095, "Propulsion Unit," granted to Wendell F. Moore (Feb. 13)

1963 Patent application on Rocket Belt with tip-driven fan thrust augmentation filed by John K. Hulbert (Sept. 19)

1964 Additional patents filed on Rocket Belt by Wendell F. Moore and John K. Hulbert (Bell Aerosystems) (July 17)  
Patent 3,149,799, "Individual Propulsion" based on rocket driven fan granted to John K. Hulbert (Sept. 22)  
Patent 3,242,144, "Personnel Propulsion Unit," granted to Wendell F. Moore and John K. Hulbert (Mar. 29)

1966 One-man pogostick vehicle flight demonstrated  
Two-man pogostick vehicle flight demonstrated  
"Flying Chair" demonstrated

1968 First kinesthetically-controlled flight of one-man pogostick vehicle made

Exploratory Work by Bell Aerosystems: The nitrogen gas powered test rig that was built in 1957, prior to the Army's issuance of their Request for Proposal, was used to investigate stability and control of a man with a strapped-on rocket, to determine where the thrust nozzle should be located and how best to apply the lift to the man's body. Figure 2.2.2.2 shows Wendell Moore suspended in the rig from the safety tether.

The rig used twin, longitudinally tiltable nozzles attached to a tubular frame which lifted the pilot via two underarm stirrups. The safety cable attached to the center of the frame above the pilot's back permitted limited flight. High pressure (500 psi) nitrogen gas was supplied by a large, remotely located 2100 psi storage tank through a flexible hose draped over a 15 foot high support. The gas passed through a fitting on the frame above and behind the pilot's head into steel tubes to which the nozzles were attached; the exits of which were located at about elbow height (with pilot's arms hanging down). Equal amounts of gas flowed through the two nozzles which were equipped with orifice plates. Thrust (gas flow) was controlled by an operator on the ground. One fore-aft control was available, arranged to tilt the nozzles by means of arm pieces directly attached to the steel tubing located over the pilot's shoulders. Lateral control was obtained by using body motion.

Test flights commenced on December 17, 1957 with Moore as the pilot and with two other pilots subsequently. Despite the restraint imposed by the flexible hose it was found that flight was possible using kinesthetic control<sup>1</sup> in combination with fore and aft tilting of the nozzles, the degree of success depending on the individual pilot's instinctive reaction. One man was able to control his flight easily while another was not able to do so, despite his having successfully flown NASA Langley's kinesthetically-controlled jet platform (Figure 2.2.2.6). Despite its crudeness, the nitrogen gas rig established the feasibility of underarm lifting for a Rocket Belt and indicated that stable operation could be achieved. Experiments using this rig started in December 1957 and continued into 1958.

Free Flight Rocket Belt Development: Since the Army contract was aimed at establishing concept feasibility at a minimum cost, proven off-the-shelf equipment was used where feasible, such as high pressure breathing oxygen bottles to

---

<sup>1</sup>Kinesthetic control is the use of body movement to provide attitude control by shifting the location of the center of gravity with respect to the lift force. Work done by NASA on this concept is described in Reference 2.4.

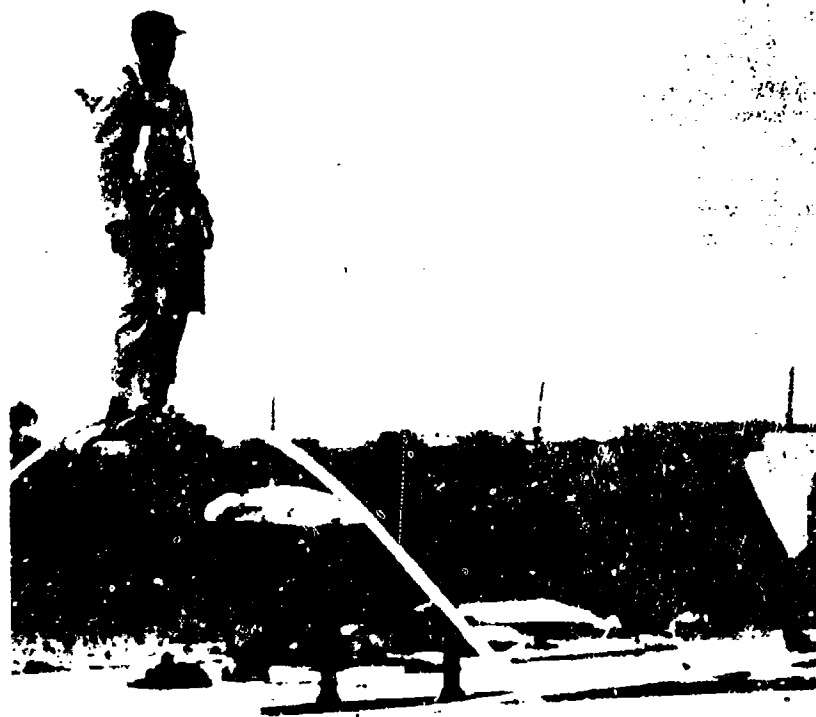

Figure 2.2.2.6 NASA Kinesthetically-Controlled Jet  
(Compressed Air) Platform in Hover Flight

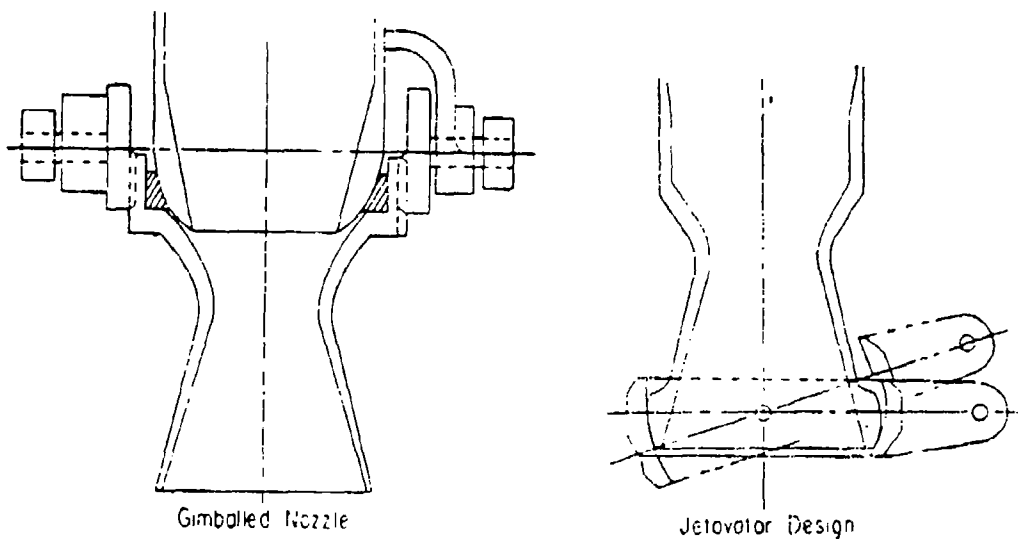

Figure 2.2.2.7 Bell Aerosystems Methods of Vectoring  
Rocket Thrust

hold the hydrogen peroxide ( $H_2O_2$ ) and the nitrogen gas used to expel the  $H_2O_2$ . Bell Aerosystems relied on their experience with  $H_2O_2$  rocket systems to adapt and design the SRLD rocket system components. This experience had been acquired during the previous work with similar rockets for attitude control of the X-18 and X-15 airplanes and the Mercury space capsule. Although the existing rocket systems from these programs were too small to generate the 300 lb thrust needed by the Rocket Belt, design technology for small rocket thrusters was adequate to permit extrapolation to the required thrust and new rocket motors were built.

Stability and control was a primary concern, believed to be the most difficult problem to solve in the Rocket Belt development. The approach taken by Moore in his June 1960 patent application (Figure 2.2.2.1) was compatible with the Aerospace-General study recommendations and, therefore, was incorporated into the initial SRLD demonstrator. Essentially, this approach was to use two separate, alternate thrust vectoring means to control horizontal translational flight with attitude stabilization being created by the flier's instinctive body motions (kinesthetic control). Specifically the flight control system had:

1. The capability to longitudinally and laterally tilt the upper assembly (gas generator, lateral gas supply tubes and rocket nozzles) of the propulsion system through movement of the pilot's arms. Lateral tilting was permitted by a longitudinally-oriented pivot on the harness and longitudinal tilting was by fore-aft flexing of the upper extension of the harness.

2. Universal gimbaling of the individual rocket nozzles (Figure 2.2.2.7) to allow differential and simultaneous tilting of the rocket thrust vectors. Control of the rocket nozzle angular movement was by a three-axis control stick whose handle or grip could be simultaneously rotated and tilted longitudinally and laterally by the flier's left hand. The rotation controlled yawing motion and flight direction and tilting controlled horizontal motion. Lateral tilt of the rocket motors was restricted to outward movement only to keep the jet blasts away from the flier.

3. A bob-weight inertia system to act on the lateral deflection of the nozzles so as to reduce lateral angular accelerations, making it easier for the flier to control his flight. A mixing linkage permitted him to override the bob-weight inputs.

4. A squeeze-type hand grip (throttle) to control the rocket thrust for lift-off, maneuvering and landing. This was located at the flier's right hand.

Testing of the initial rocket belt system in tethered flight revealed difficulties with the control system, which used rocket nozzle tilting, and with the throttle control. With the rocket assembly pivoting freedom locked out (item 1 above) and with control solely through rocket nozzle tilting it was found that the three-axis stick system was overly sensitive to pilot control inputs. Further, the gimballed system did not maintain good neutral alignment. Regarding the squeeze type throttle control, it was found to produce poor thrust response characteristics.

The gimballed nozzle system was replaced by a less sensitive device, a universally tiltable ring ("Jetavator") located at the nozzle exit (illustrated in Figure 2.2.2.7). A motorcycle twist-type hand grip replaced the squeeze-type throttle control. With these changes the Feasibility Demonstrator was able to operate successfully in free flight and provide the satisfactory flight demonstrations required in the contract. Subsequent, improved Rocket Belt versions (Figure 2.2.2.8), built solely with company funds, basically were similar to the Feasibility Demonstrator. Simplifications were made in the harness and lateral tilting of the nozzles (Jetavator) was eliminated.

It should be noted that the H<sub>2</sub>O<sub>2</sub> rocket produced a very high noise level, 150 pndb near the source, sufficient to cause strong discomfort to unprotected ears.

The SRLD demonstrator used three high pressure bottles mounted side-by-side on a harness at the pilot's back, the two outside bottles contained the H<sub>2</sub>O<sub>2</sub> and the center bottle stored the pressurizing nitrogen. A fiberglass corset-like unit, molded to fit the pilot, was used to transfer the SRLD's weight (110 lbs) to the man's hips and legs when standing on the ground prior to flight. The H<sub>2</sub>O<sub>2</sub> flowed through a catalytic chamber (with silver screen catalyst) and the resulting 1300°F gases (steam plus oxygen) flowed through the lateral tubes to the nozzles. These tubes were insulated on the outside to protect the pilot and reduce gas heat loss.

Because of the short flight duration available (21 seconds), a pilot warning device was required to tell him when to initiate his landing. After testing a combined visual (flashing red light mounted front and side of the helmet) and audio system (sound generated inside the helmet), it was decided that these were not foolproof because of the background high noise level and the possibility of blocked vision by mud being splashed on the goggles. The final system selected was a vibrator installed at the back of the pilot's helmet with power being supplied by a 6 volt dry cell battery. A timer was incorporated which started automatically upon initial thrust application. After 10 seconds elapsed time an intermittent vibration was transmitted to the pilot's skull; at 15 seconds the vibration became continuous indicating 6 seconds left for

**TRENDS IN TECHNOLOGY**

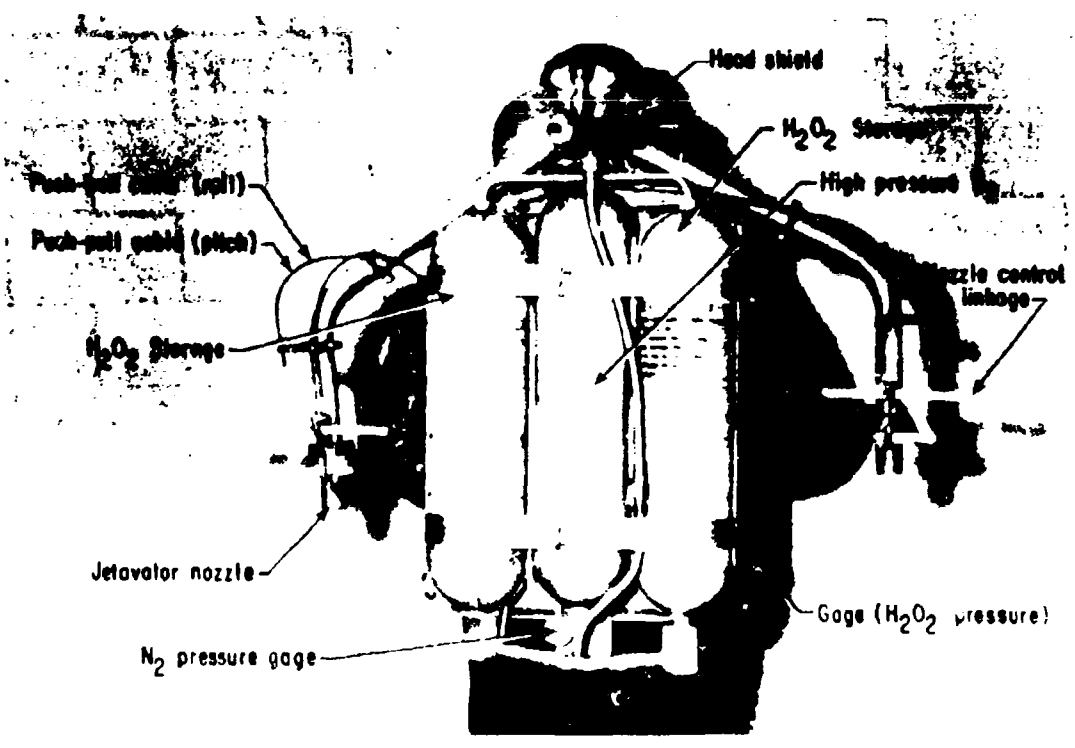
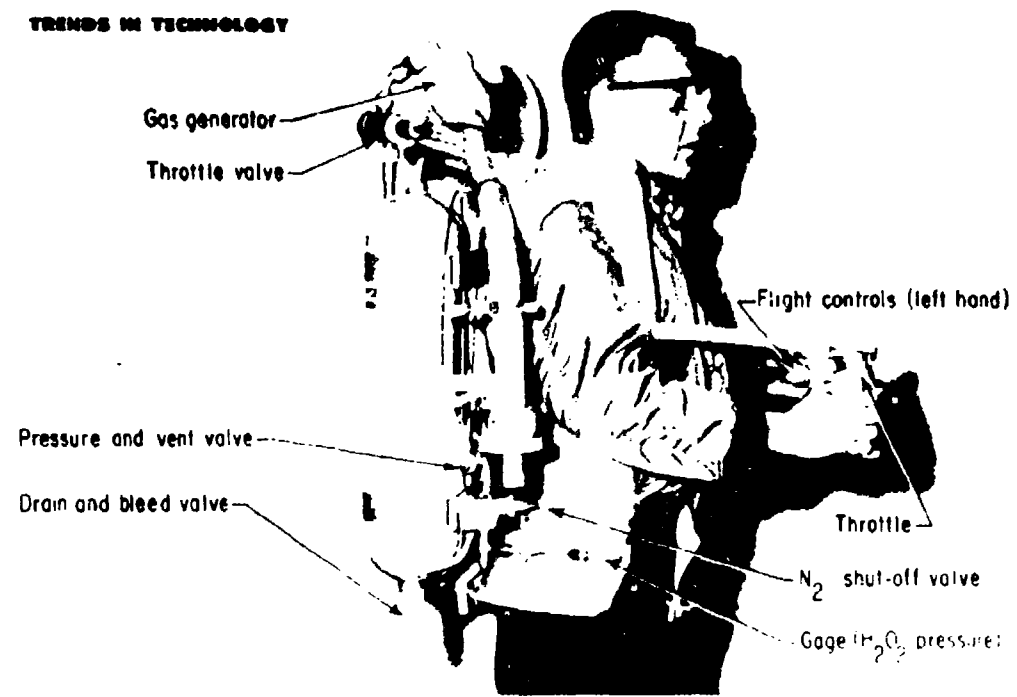

Figure 2.2.2.8 Bell Aerosystems SRLD Feasibility Demonstrator for U.S. Army (Courtesy Bell Aerosystems Co.)

landing. The timer was located on the right hand control arm and had a dial visible to the pilot providing him an additional, visual, flight time indicator.

Subsequent Rocket Device Developments: The final Rocket Belt developed by Bell (Figures 2.2.2.9 and 2.2.2.10) had the following specifications:

TABLE 2.2.2.2

SPECIFICATIONS OF BELL AEROSYSTEMS ROCKET BELT

Throttleable Thrust	0-300 lb
Empty Weight	63
Propellant Weight	47
Takeoff Weight	110
Propellant	H <sub>2</sub> O <sub>2</sub> (90% concentration)
Maximum Range	866 feet
Altitude	80+ feet (normally used)
Maximum Speed	60+ mph
Maximum Flight Duration	21 seconds

In an effort to improve flight duration and distance, Moore designed a pump-fed system to eliminate the weight of the nitrogen gas tank and permit an increased supply of H<sub>2</sub>O<sub>2</sub>. He also considered the use of wings such as the Rogallo type to increase the range and duration of flight. A patent application for this concept was made. Also, on February 14, 1961, John K. Hulbert at Bell Aerosystems proposed an augmented thrust system using twin H<sub>2</sub>O<sub>2</sub> driven turbofans to replace the original rocket nozzles (Figure 2.3.1.2). A patent application filed during September 1963 was granted on September 22, 1964 (Patent No. 3,149,799).

An interesting development during the SRLD program was the analog-type trainer created by Bell (Figure 2.2.2.11) to reduce expense and increase safety during pilot training. Equations of motion, derived for the man-machine combination, were used to construct an analog computer. The pilot trainee learned to handle the Rocket Belt controls by observing a moving image displayed on an oscilloscope screen.

A limited effort to develop the Rocket Belt further was made but discontinued in favor of the gas turbine approach. Bell Aerosystems used the Rocket Belt system to develop a one-man and a two-man stand-on platform ("Pogo") devices (Figures 2.2.2.3 and 2.2.2.4) for NASA. These were used to investigate handling qualities and control methods for Lunar Flying Vehicles and Earth mobility systems. Initially, thrust vector control was used and, subsequently, kinesthetic control was tried.



Figure 2.2.2.9 Final Configuration of the Bell Aerosystems Rocket Belt, in Flight (Courtesy Bell Aerosystems Co.)

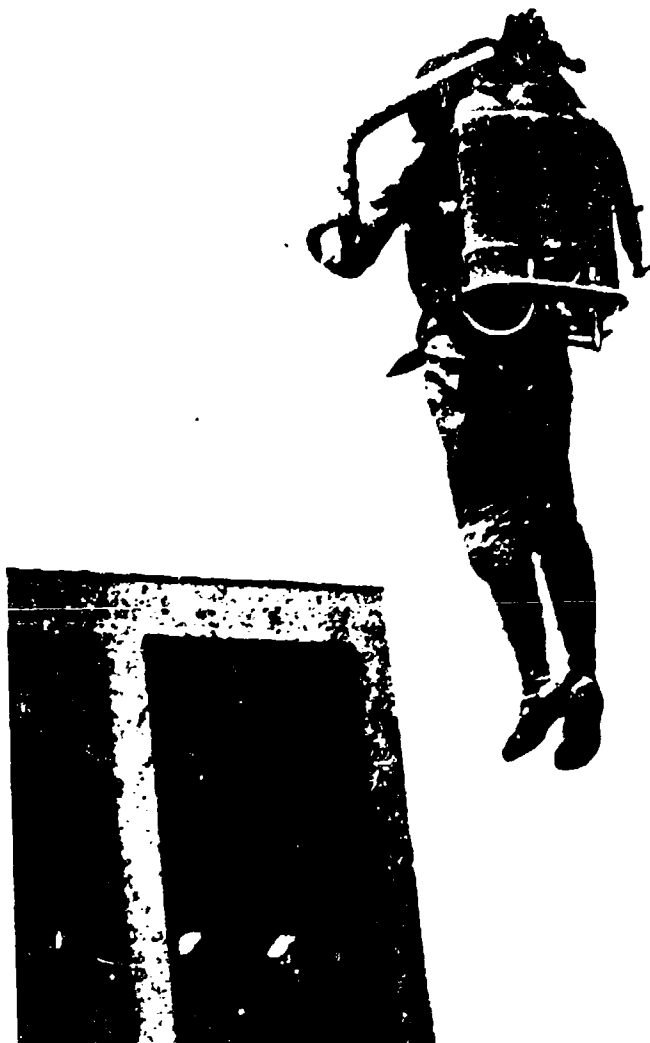

Figure 2.2.2.10 Flight with Bell Aerosystems  
Rocket Belt, Rear View  
(Courtesy Bell Aerosystems Co.)



Figure 2.2.2.11 Bell Aerosystems Analog-Type  
Rocket Belt Pilot Trainer  
(Courtesy Bell Aerosystems Co.)

Flight testing of the single place "Pogo" started in 1966 using thrust vector control and, late in 1968, the first kinesthetically controlled flight was made. The two-man vehicle was, essentially, two single-place units fastened together on a new platform. This vehicle also has been flown using thrust vector and kinesthetic control. Flights were made with passengers varying in weight from 115 to 190 lbs with no noticeable effect on control or flight characteristics.

The success of these efforts led to a \$250,000 contract from NASA in 1968 for the design of a Lunar Flying Vehicle.

Weights and thrusts of the vehicles were:

	<u>Rocket Belt</u>	<u>Single-Place Pogo</u>	<u>Two-Place Pogo</u>
Empty Wt, lb	63	80	147
Max. Thrust	300	300	600

Noteworthy on the one-man Pogo is the location of the propellant tanks ahead of the pilot and the lowered position of the rocket nozzles, slightly above knee height. On the two-man device the nozzles were slightly below shoulder height.

Concluding Observations: Bell Aerosystems' development of the Belt and Platform type rocket-propelled VTOL devices was highly successful and demonstrated well the feasibility of control by vectoring of the rocket thrust or by kinesthetic body motion. Rocket propulsion provided the simplest possible approach to individual VTOL flight and proved to be extremely reliable.

Although the concept aroused considerable attention and interest, seeming to be an answer to providing individual mobility, it had three drawbacks: relatively short flight duration, very high noise, and the need for special fuel. These, particularly the short duration characteristic, eliminated it from further consideration and led to efforts to try to increase duration by augmentation of the basic rocket thrust.

The principles proven by the rocket-propelled devices have been the basis for the subsequent turbofan platform approaches which still were under development into the early 1980's.

2.2.3 Aerojet-General Corporation Small Rocket Lift Device (SRLD) Study for the U.S. Army (TRECOM) (1958-1959)

After winning the U.S. Army Transportation Research Command competition for the study of the SRLD and being awarded Contract No. DA44-177-TC-595 for \$56,456 in July 1958, Aerojet-General conducted an eight-month analytical effort which produced References 2.2 and 2.3. Prior to the contract the company had studied, on their own, various configurations of SRLD's and had built and thoroughly tested a tethered version of one of the more promising configurations. Unfortunately, no information was available on these efforts.

The objective of the study was to determine the feasibility of applying small rocket lift devices to increasing the mobility of the individual soldier. Review of References 2.2 and 2.3 shows that the study was done well and quite thoroughly. Based on analysis, it was concluded that a SRLD could be made to work and it was recommended that a demonstrator be built and tested. This led the Army to undertake funding of a demonstrator program, awarding the new contract to Bell Aerosystems. During the early stages of Bell Aerosystem's contracted effort, there was cooperation between them and Aerospace-General.

Primarily, the Aerospace-General study concerned itself with two areas: the propellant or fuel for the rocket system and the stability and control of the device. The latter concern occupied most of the effort since it was considered to be the most critical aspect in determining the feasibility of SRLD'S.

Propellants: A wide variety of propellant systems and propellant combinations was examined to assess their relative merits and deficiencies and to identify the promising candidates. This screening resulted in:

1. The recommendation of a specific propellant for the flight demonstrator.
2. Identification of a number of feasible propellant systems.
3. The provision of an advanced starting point for propellant selection for use in a prototype-production vehicle.

With respect to (1) above, the monopropellant  $H_2O_2$  was recommended for the SRLD demonstrator because of that propellant's easy starting (using a catalyst bed), readily controllable thrust (by flow regulation), non-toxicity including the exhaust products (steam and water) and its relatively low decomposition temperature (1370°F) permitting use of an uncooled structural assembly of conventional materials. Furthermore,

existing knowledge and experience with  $H_2O_2$  was excellent, greatly reducing the SRLD propulsion system development risk.

The propellant systems considered for a future, production version of a SRLD included monopropellants, bipropellants, solids and hybrids (solid plus liquid). Reference 2.2 provides a review of these along with recommendations for follow-on research and development on the most promising propellant systems.

Noise: Aerojet-General was well-aware of the noise problem and, in connection with the contracted study, did some theoretical analysis and testing. Company tests of small rockets (100 lb thrust) indicated an approximate noise level of 157 db at the source. They estimated the noise at 158 db for a 300 lb thrust system. An attempt to reduce noise by using a fluted instead of a conical nozzle resulted in only a small noise level decrease. It was found that ear plugs worked satisfactorily and they were recommended for the SRLD operator and for close-by ground personnel.

Stability and Control: Aerojet-General investigated various SRLD configurations prior to and during the contracted study. Some were found to be attractive and others were eliminated early from further consideration because of their obviously undesirable features. Selection of a particular SRLD configuration was necessary to permit the carrying on of the stability and control study. Also, it was necessary to define the arrangement and characteristics of the device's components and the physical characteristics of the typical operator. Propulsionwise, a simple, pressure-fed monopropellant approach was selected. Among the characteristics needed were center of gravity location, moment of inertia, weight, thrust, specific impulse, man-machine response times and reaction times. This information was used to develop the equations of motion and, using digital computers (IBM704 and 610), determine flight trajectories. Results of these computations indicated that the selected SRLD configuration (back-pack) was stable and capable of being operated safely by an unskilled individual with limited training for normal trajectories, as defined in the study. A flight of 100 foot length at 30 foot altitude was selected to permit examination of the efficiency of the various control geometries. Basically, the SRLD was to have only an extended jump capability in keeping with the Army's objective.

During configuration selection, Aerojet-General considered various arrangements of the SRLD--single and multiple engines located at the front, back, side, top or below the operator; stand-on, sit-on platforms and strap-on arrangements. Of these, the one selected was the strap-on, back-pack with two motors, one at each side with their thrust vectoring pivot axes above the center of gravity (c.g.). Analysis determined that the best location was 11.0 inches above the man-machine c.g.

(with half the fuel expended) and 15 inches to each side of the operators's centerline in the plane of symmetry. Characteristics taken from the SRLD design specification were used; it should be noted that no attempt was made to optimize the device, that being beyond the scope of the contract.

TABLE 2.2.3.1

SRLD DESIGN SPECIFICATION

Flight Duration	14.1 seconds
Total Thrust (maximum)	310 lbs
Total Impulse	4650 lb-sec
SRLD Weight, Less Propellant	75 lbs
Propellant Weight	45 lbs
Pilot Weight, Maximum	160 lbs
Total Initial Weight	280 lbs
Specific Impulse	100 lb/lb/sec
Chamber Pressure	80 psia
Combustion Temperature	1330°F
Thrust	Controllable
Type Fuel	Monopropellant
Controls	Thrust, pitch, yaw, roll
Mounting	Back pack with total load transmitted to to operator's hips when standing upright

A girdle plus chest strap arrangement was to be used to carry the SRLD components.

Aerojet-General recognized the merit of kinesthetic control and considered it to be the preferred control means for the two platform types (sit-on and stand-on). For the strap-on type, however, they selected thrust vector control, apparently believing that the kinesthetic approach would be too difficult to use. They did use fore-aft leg movement, however, as a means to balance the c.g. shift due to fuel depletion. The control system used was:

Longitudinal: Fore-aft tilt of the rocket motor thrust vectors via gimballed nozzles mounted above the c.g. for producing both pitching moments and longitudinal translation.

Lateral: Differential thrust variation between the two rocket motors to produce rolling moments. Lateral translation followed the resulting lateral tilt (roll angle) of the man-machine system. The rocket motors' thrust lines were parallel to the operator's plane of symmetry.

Yaw: Fore-aft tilt of one of the rocket thrust vectors via a "Jetavator". A yawing moment of 2.5 ft-lb was considered to be adequate.

Vertical: Simultaneous thrust variation of both rocket motors was used to control ascent and descent.

The foregoing were to be produced by hand manipulated controls with the sense of motion for longitudinal, lateral and yaw being the same as the desired flight direction.

The control system was aimed primarily at maneuvering in the pitch plane. Lateral translation was not considered necessary, the roll control being mainly for the purpose of stabilizing flight and opposing side winds. It was assumed that in the preferred flight operation, the operator would tend to continuously face his landing spot.

Aerojet-General's determination of concept feasibility rested on whether the man-machine combination (operator plus SRLD) was inherently stable. While the SRLD itself was not inherently stable in the conventional airplane sense, it was intended that the operator himself would provide, via the controls, corrective forces and moments to hold or change attitude and damp unwanted motions.

Concluding Observations: On the basis of the information supplied in References 2.2 and 2.3 it is concluded that:

1. The study and analysis were well done and sufficiently comprehensive to permit a theoretical determination of SRLD concept feasibility. It provided a credible basis for assuming that the SRLD could be successful.

2. It helped the U.S. Army (TRECOM) reach a decision to fund the SRLD Demonstrator.

#### 2.2.4 Thiokol-Reaction Motors Division "Jump Belt"

Thiokol-Reaction Motors Divisions' (RMD) interest in individual lift devices began in 1957, before the Army's official initiation of the SRLD effort. In September of that year RMD designed a small, one-man VTOL vehicle lifted and propelled by an air breathing jet engine and aimed at short distance flight. Their involvement in rocket-powered lift systems dates from January 1958, when they became aware of the U.S. Army TRECOM's interest in using small rockets to improve the foot soldier's mobility. RMD believed that they should be involved in such developments because rocket propulsion was their field of interest and expertise.

Starting in January 1958 the RMD carried out, on their own, a substantial effort to investigate such lift devices exploring their feasibility and determining how best to approach the problems involved. Their efforts were terminated immediately after TRECOM's award of the demonstrator contract to Bell Aerosystems in August 1960. RMD's basic requirements for all individual lift systems were that: they should be capable of being worn by the operator, employ propellants having easy field use, be devices requiring minimum maintenance and serviceable by the operator himself in the field. Desired qualities for the propulsion system were: high thrust/weight, high thrust/volume, low specific fuel consumption and one-hand control. Unlike Bell Aerosystems and Aerojet-General, who looked on individual lift devices as basically free-flight systems, RMD divided them into two distinct classes--"Jump Belts" and "Flying Belts", defined by their flight capabilities. The Jump Belt was considered to be a compact, light-weight, jet thrust device worn by the soldier to help him in such activities as running, jumping and water skimming. Operating time was to be short, less than ten seconds at reduced thrust (thrust/weight < 1). The Flying Belt was defined as a unit which could completely sustain an individual and permit him to fly for several miles. Based on analysis RMD believed that a jet engine, with its much lower fuel consumption, was the best power source for a Flying Belt. Interestingly, RMD's conclusions were confirmed later by Bell Aerosystems and the Army when they abandoned the Rocket Belt for the turbojet approach.

Specifically RMD's proposed Jump Belt was aimed at providing the performance shown in Figure 2.2.4.1. The Flying Belt, on the other hand, was to be capable of VTOL and hover, flying 10 miles at 60 mph, and climbing vertically to at least one mile. In the following, essentially the Jump Belt efforts are covered.

The key individual behind the Jump Belt was Alexander H. Bohr, a project engineer in the Advanced Engineering Group. He generated the conceptual approaches and supervised the research and development. His work led him to

### SOLDIER WITH AND WITHOUT JUMPBELT

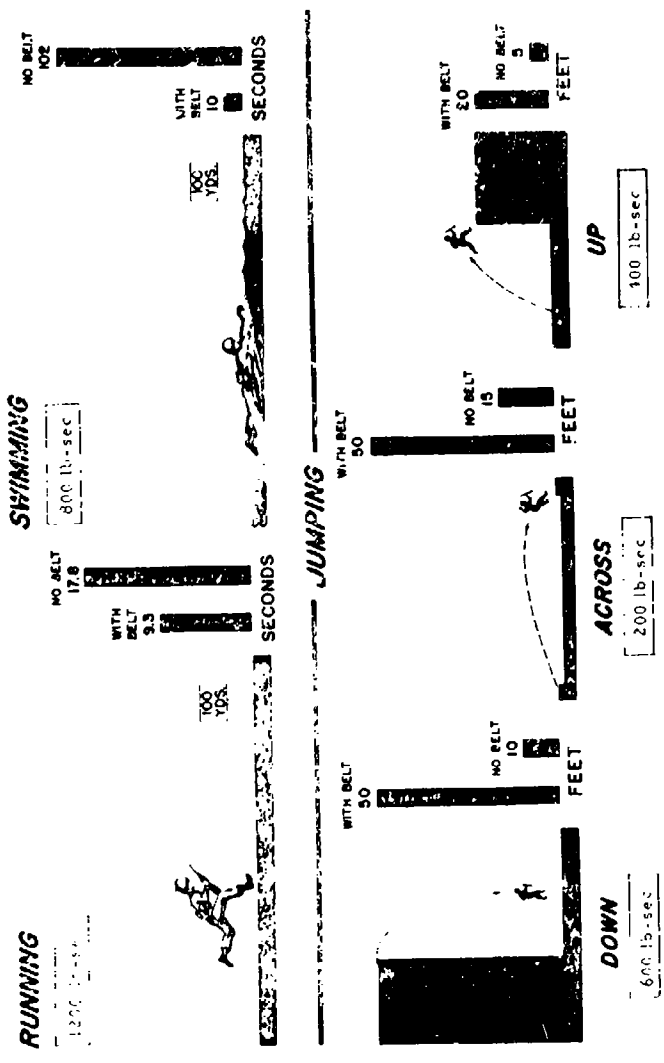

Figure 2.2.4.1 Improvement in Capability with Jump Belt  
 (from Reference 2.10)

apply, on June 18, 1958, for a patent on the Rocket Belt, officially designated as a "Jet Device". On June 19, 1962, he was granted Patent No. 3,039,716 from which Figure 2.2.4.2 is taken. Bohr also was responsible for preparing the Thiokol RMD proposals made to the Army, three of which (References 2.8, 2.9 and 2.10) were in response to TRECOM's RFP's for Phases I and II of the SRLD program. An earlier, unsolicited proposal submitted in August 1958 preceded the Army's first RFP aimed at the SRLD study. Two of RMD's proposals (References 2.8 and 2.10) provided the information used in this subsection (2.2.4) of the report.

Solid Propellant Jump Belt: Various jet propulsion approaches were evaluated by RMD for the Jump Belt ranging from rockets using propellants such as cold-compressed gases; liquid and solid fuels to airbreathing jet engines. Of these, the solid propellant rocket appeared to be the most attractive because, compared with liquid propellant systems such as  $H_2O_2$ , it was lighter, easier to handle and had a better-established base in practical usage. Design analysis produced the solid propellant design shown in Figure 2.2.4.3. Figure 2.2.4.4 shows the solid propellant Rocket Belt, in mock-up form, worn by a soldier. The largest jet belt (25 lbs total weight, 2400 lb-sec energy content) was capable of producing 120 lbs thrust for 20 seconds, enough to give a running individual a 30 mph capability for 300 yds. It should be noted that no solid propellant rocket belts were actually built; the only Jump Belts built and tested used compressed nitrogen or hydrogen peroxide.

Of the various applications visualized by RMD, listed on Figure 2.2.4.3, one is especially noteworthy, that of paratroop landing deceleration. The Soviet Union has such a system in operational military use for parachute delivery of cargo (Reference 2.11).

Proposed  $H_2O_2$  Jump Belt for TRECOM SRLD: After the results of the Army's contracted study with Aerojet-General were released (Reference 2.2) and in response to the RFP to build and demonstrate a SRLD, RMD proposed the concept shown in Figure 2.2.4.5. It differs from the Bell-Aerosystems development primarily in the amount of propellant carried and the control means used. The principal characteristics of this Jump Belt are summarized in Table 2.2.4.1

Other noteworthy features were:

1. Use of a slender, vertical  $H_2O_2$  tank to minimize fore-aft c.g. change.

2. The use of a single chamber to provide gas flow to the twin, hip-located nozzles to assure equal thrust.

3. Pre-flight adjustable nozzle angles and horizontal position location to permit experimentation on the SRLD for thrust vector--c.g. effects.

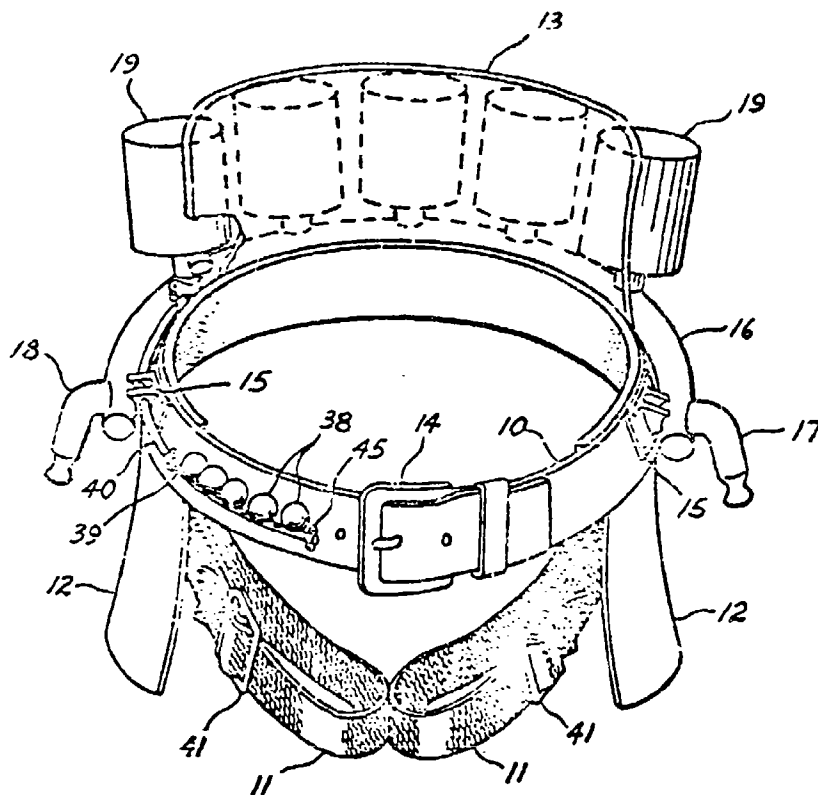

- 10 Belt
- 11 Adjustable Straps
- 12 Leg Protector Pads
- 13 Back Support Protector
- 14 Belt Buckle
- 15 Manifold Attachment Fittings
- 16 Hollow Manifold
- 17,18 Nozzles
- 19 Fuel Cannisters
- 38 Actuating Knobs for Cannisters
- 39 Knob Cable
- 40 Cable Casing
- 41 Strap Buckles
- 45 Knob Attachment Clips

Figure 2.2.4.2 Jump Belt Concept Patented by Alexander H. Bohr of Thiokol, Rocket Motor Division (taken from Patent 3,039,718)

## Product Data

Dimensions and weights of jumpBelts for various energy ranges are listed below. Data are based on 160 lb man with 40 lb total load.

Models required for special applications can be readily assembled by minor modifications to basic units listed here.

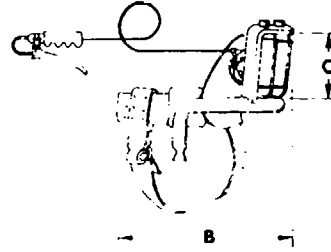
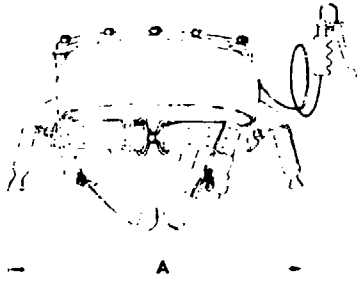

## Specifications

Total Energy Content, lb-sec  
 Basic Unit Weight, lb  
 Propellant and Canister Weight, lb  
 Total Weight, lb  
 Width - A, in.  
 Depth - B, in.  
 Height - C, in.

	600	1200	2400
Total Energy Content, lb-sec	600	1200	2400
Basic Unit Weight, lb	5.5	6.25	7.0
Propellant and Canister Weight, lb	5.1	13.1	18.0
Total Weight, lb	10.6	16.35	25.0
Width - A, in.	18	18	18
Depth - B, in.	12	12	12
Height - C, in.	6	6	10

## Applications

Combat assist for ground troops  
 Brake parachute drops of men and equipment  
 Low level bailout from disabled aircraft

Traverse water on surface or underwater  
 Emergency rescue squads  
 Assist vehicles over difficult terrain

Figure 2.2.4.3 Thiokol RMD Proposed Production Solid Propellant Jump Belt (Brochure Information)



Figure 2.2.4.4 Thiokol RMD Mock-Up of Solid Propellant  
Jump Belt (from Reference 2.8)

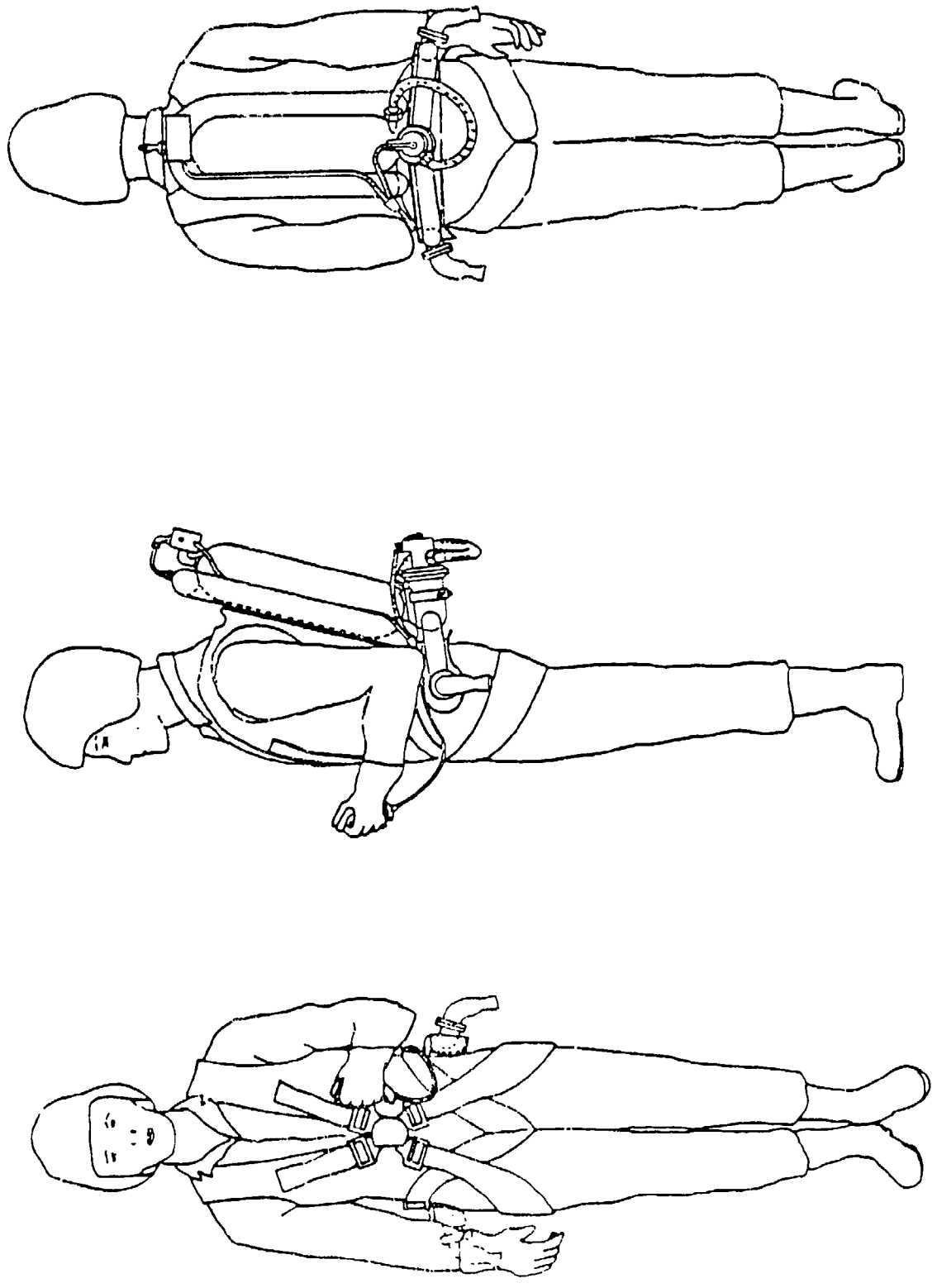

Figure 2.2.4.5 Three Views of Thiokol RMD Hydrogen Peroxide Pump Belt Configuration (from Reference 2.10)

4. Use of twin nozzles, one at each hip, and canted 15° outwards to keep jet blast away from the operator's limbs.

5. Tubular structure serving as system mount and storage chamber for compressed nitrogen used to expel the H<sub>2</sub>O<sub>2</sub>.

6. H<sub>2</sub>O<sub>2</sub> throttle control mounted at end of a cable system permitting the control to be put into either hand.

7. Reliance on body motion only for control; no thrust vectoring control system was incorporated. Based on RMD's experimental work it was believed that kinesthetic control would be satisfactory for the Jump Belt's short duration operations.

8. For jumping, a thrust level of 300 lbs (0.5 g vertical acceleration) was desired; with a 1200 lb-sec total impulse this thrust could be maintained for 4 seconds. According to RMD, this would permit ample vertical leaping with good energy reserve. Running and water skimming would be done using about 120 lbs thrust, good for 10 seconds operation. This was considered adequate to perform reasonable ground maneuvers.

TABLE 2.2.4.1

THIOKOL RMD JUMP BELT (SR1D) DEMONSTRATOR CHARACTERISTICS

Propellant	H <sub>2</sub> O <sub>2</sub> (90% concentration)
Thrust	60 to 300 lbs
Specific Impulse	122 seconds
Total Impulse	1200 lb-sec
Gas Generator	Single chamber with silver screen catalyst
Rocket Motor Chamber Pressure	200 psia
Combustion Temperature	1340°F
Nozzles	2 located at the operator's hips
Nitrogen Chamber Pressure	2200 psia
Harness	Corset type with quick release harness
Control	Kinesthetic only plus throttle
Weights:	
1. Operator	162 lbs
2. Jump Belt Operating Weight	46.6 lbs
3. Personal Equipment	9 lbs (clothes, shoes, helmet)
4. Jump Belt Dry Weight	27 lbs
5. H <sub>2</sub> O <sub>2</sub>	10 lbs
6. Nitrogen	0.6 lbs
7. Gross Weight	208.6 lbs

Proposed Flying Belt: Although RMD believed that rocket power systems should be applied primarily to Jump Belts, they did design rocket Flying Belts in an effort to respond to the Army's interest in such, despite the limited flight duration possible. Two propellants were examined: solid and liquid ( $H_2O_2$ ). The solid propellant system was attractive because it was lighter and more compact than the liquid type but had the basic limitation that, once ignited, combustion could not be stopped; thrust was to be controlled by gas venting. Because this led to excessively wasteful operations the concept was abandoned. A system flight weight of 44.3 lbs was estimated for a thrust of 285 lbs for 10 seconds.

Figure 2.2.4.6 shows the  $H_2O_2$  Flying Belt design included in References 2.9 and 2.10. This unit was to have 310 lbs thrust for 13.2 seconds. In their Flying Belt concepts, RMD located the nozzles at shoulder height, well above the c.g. and used thrust vector control via nozzle swiveling to provide for flight maneuvering. Control was to be through a one-hand control stick. Indications are that RMD believed that kinesthetic control could not be used with a Flying Belt.

Consideration was given to the use of aerodynamic lifting surfaces to extend duration and range.

RMD's Experimental Work: From 1958 through 1960, Thiokol RMD carried out a number of design studies and experimental efforts to obtain background and solutions to the Jump Belt. The first successful Jump Belt was tested in the spring and summer of 1958. It used two and, alternatively, three nitrogen bottles charged to 1500 psi. The nozzles were located at the hips close to the c.g. line. A thrust of 350 lbs was available for as much as 5 seconds. Successful jumps were made 30 ft horizontally and 15 ft high using kinesthetic control (Figure 2.2.4.7). Twenty-two mph running (briefly) was done also. This belt was demonstrated to the Army in June 1958. Subsequently, in late 1958 to early 1959, RMD built a 200 lb-sec total impulse  $H_2O_2$  Jump Belt (Figure 2.2.4.8). With this it was proven that a hot gas system could be used with relative safety. There was no problem with the hot gases in the proximity to the operator's body and the system was shown to be light in weight, flexible and without hindrance to his movements. This  $H_2O_2$  Jump Belt was demonstrated to the Army in February 1960. Upon the contract award to Bell Aerosystems in August 1960, Thiokol RMD discontinued further development efforts.

#### Concluding Observations:

1. With regard to the Jump Belt concept, Thiokol RMD carried out useful development efforts and proved that, with such a device, an individual could improve his jumping, leaping and running capability. Only kinesthetic and thrust level control were required.



Figure 2.2.4.6 Thiokol RMD Small Rocket Lift Device (SRLD) Configuration  
Using Hydrogen Peroxide (from Reference 2.10)



Figure 2.2.4.7 Jumping with Thiokol RMD Nitrogen Gas  
Jump Belt (from Reference 2.8)



Figure 2.2.4.8 Thiokol RMD Low Capacity (200 lb/sec)  
Hydrogen Peroxide Jump Belt Ready for Use

2. Their exploratory efforts in the Flying Belt area were limited essentially to design studies; no attempt to prove flight capability was made. RMD's preference for an air-breathing jet engine Flying Belt approach was vindicated by the subsequent shift in military interest away from Rocket Belts to gas turbine-powered systems.

3. Despite abandonment of the Jump Belt approach by the Army, there still may be useful applications for the concept in such areas as paratroop recovery and other activities requiring only brief use of thrust.

## 2.3 AUGMENTED ROCKET THRUST VEHICLES

### 2.3.1 Introductory Comments

Augmentation of rocket thrust is aimed principally at reducing the fuel consumption (increasing the specific impulse) of the rocket. Primarily, two thrust augmentation systems are available: ejector and fan or thrust-producing rotor. The ejector is a jet pump with no moving parts and is basically similar to the ejectors used with jet engines in such VTOL aircraft as the XV-4A and XFV-12A to be described in Section 3. In the rocket system, the primary flow is provided by the rocket's exhaust, paralleling the jet engine's exhaust action in the ejector chamber. However, the higher velocities (Figure 1.18) and, most often, higher temperature of the rocket exhaust make effective mixing of primary and secondary (ambient air) flow more difficult, resulting in lower thrust augmentations than are practically obtainable with jet engines. To date, only one rocket-powered VTOL vehicle with an ejector has been built, the French "Ludion"; it obtained an actual thrust amplification of 1.5. The "Ludion" is discussed in Section 2.3.2.

Fans and rotors, on the other hand, can produce relatively much larger rocket thrust augmentations, depending on their diameters (disc loading). The only VTOL aircraft which have been built with rocket powered rotors are helicopters, an example of which is the recent Aerospace General helicopter (Figure 2.3.1.1a), representing another approach to providing individual lift. The rotor of this machine augments the rocket thrust by a factor of about 20, that is 30 lb of total rocket thrust at the rotor blade tips produces 600 lb of rotor lift. Obviously, there is a penalty in system weight, complexity, and operating space needed compared with the pure ejector system. Figure 2.3.1.1c is the hydrogen peroxide rocket unit showing its small size; on this helicopter, two of these motors can provide in excess of 94 horsepower to the rotor. Figure 2.3.1.1b points out the installation of the rocket motor in the blade tip. Information on this helicopter was obtained from Reference 2.12.

Fan systems, with their higher disc loadings, produce a lower thrust augmentation than helicopter rotors but they are, generally, less complicated. However, they can produce higher augmentations than ejector systems. Such fans may be shrouded or unshrouded and the rocket thrust can be applied by jets issuing from the blade tips or, in the shrouded system, by jets coming from stationary nozzles and impinging on turbine blades peripherally mounted around the fan.

No actual vehicles with total lift produced by rocket-driven fans have been built, but such have been considered. In an effort to increase the Rocket Belt's flight time, John K. Hulbert at Bell Aerosystems proposed, in 1963, a

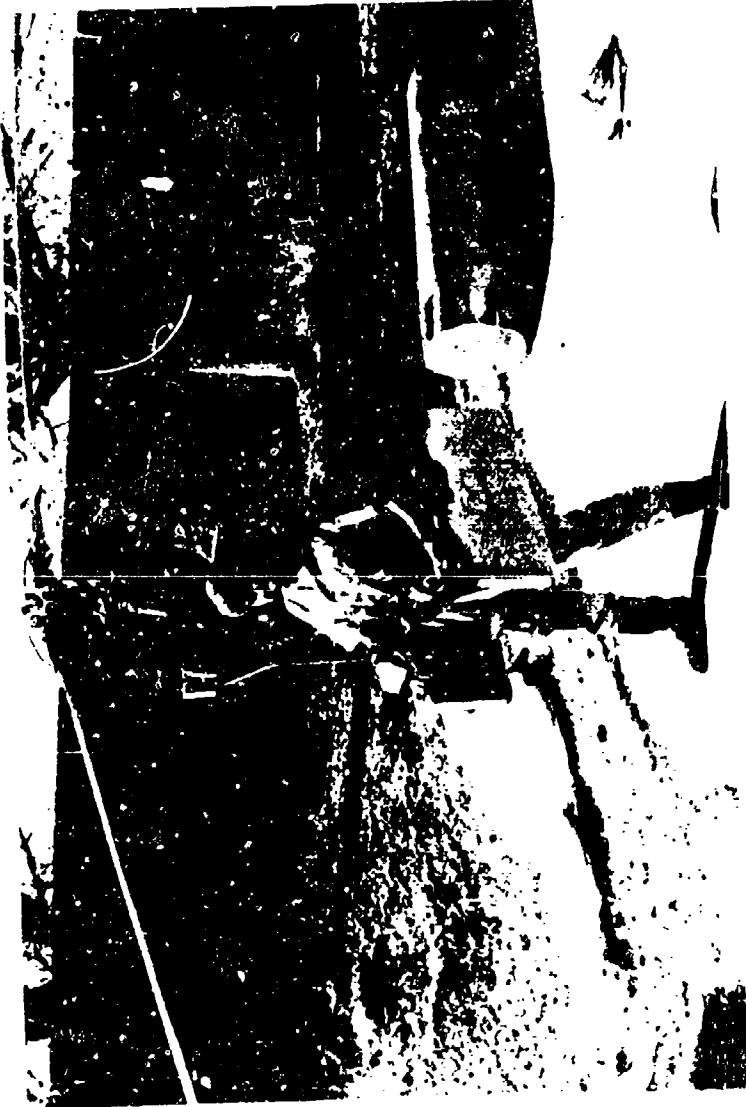

(a) Helicopter Attached to Operator  
Figure 2.3.1.1 Aerospace General Rocket Powered Helicopter  
(Courtesy Aerospace General Corp.)

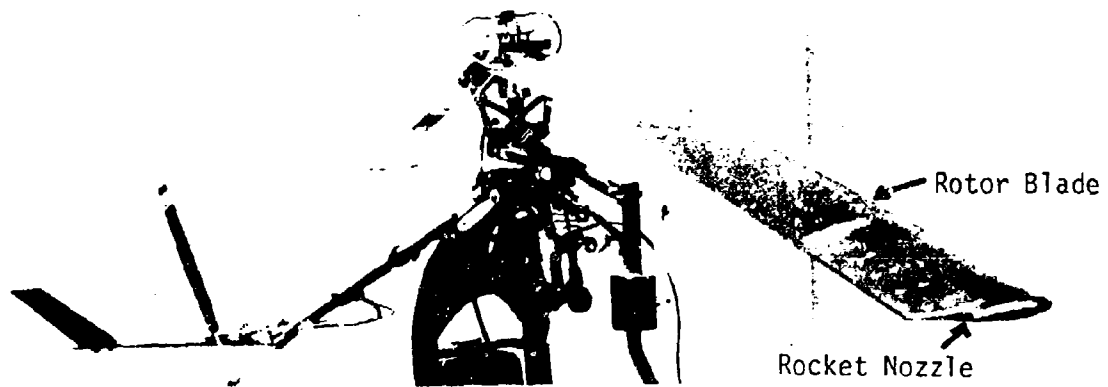

(b) Rocket Nozzle in Blade Tip



(c) Rocket Motor and Nozzle

Figure 2.3.1.1 (continued)

rocket-driven shrouded fan system for the Rocket Belt (Figure 2.3.1.2) and received Patent No. 3,149,799 on September 22, 1964. Bell Aerosystems actually built a hydrogen peroxide-powered fan unit and demonstrated an overall specific impulse of more than double that of the existing Rocket Belt.

The Martin Company incorporated a rocket-driven fan system to provide supplementary vertical lift in a tilt-wing VTOL airplane design (Figures 2.3.1.3 and 2.3.1.4) studied in early 1960 (Reference 2.13). Called the "super-fan" by Martin, the fan was intended to supply 7700 lb of lift to a 13,000 lb airplane during VTO operation. The fan used  $H_2O_2$  plus JP-4 to power rockets mounted in the blade tips and was projected to augment the blade tip rocket thrust by a factor of about 6.25. This 52-inch diameter hypothetical fan was to operate at a supersonic tip speed of 1800 feet per second and had a projected total system thrust-to-weight of 10.7 (dry). Tip rocket specific impulse was 230 sec and the effect of the fan's thrust augmentation was to produce a complete system specific impulse of 1440 at vertical take-off thrust. This increased to 1895 during vertical landing (3850 lb thrust). Corresponding disc loadings were 542 and 271 pounds per square foot. It is interesting to note that the rockets produced 4900 horsepower when the fan was delivering 7700 pounds of thrust.

For individual lift devices either shrouded or unshrouded type rocket-driven fans can be used. Each has merits and drawbacks. For example, the shrouded system allows use of smaller diameter fans for the same static thrust. The shroud also acts as a safety guard and noise suppressor. Inlet guide vanes to improve fan efficiency and modulate thrust and exit vanes to vector the thrust can be readily installed. However, the shroud has high drag and pitching moment in translational flight if its axis remains approximately vertical.

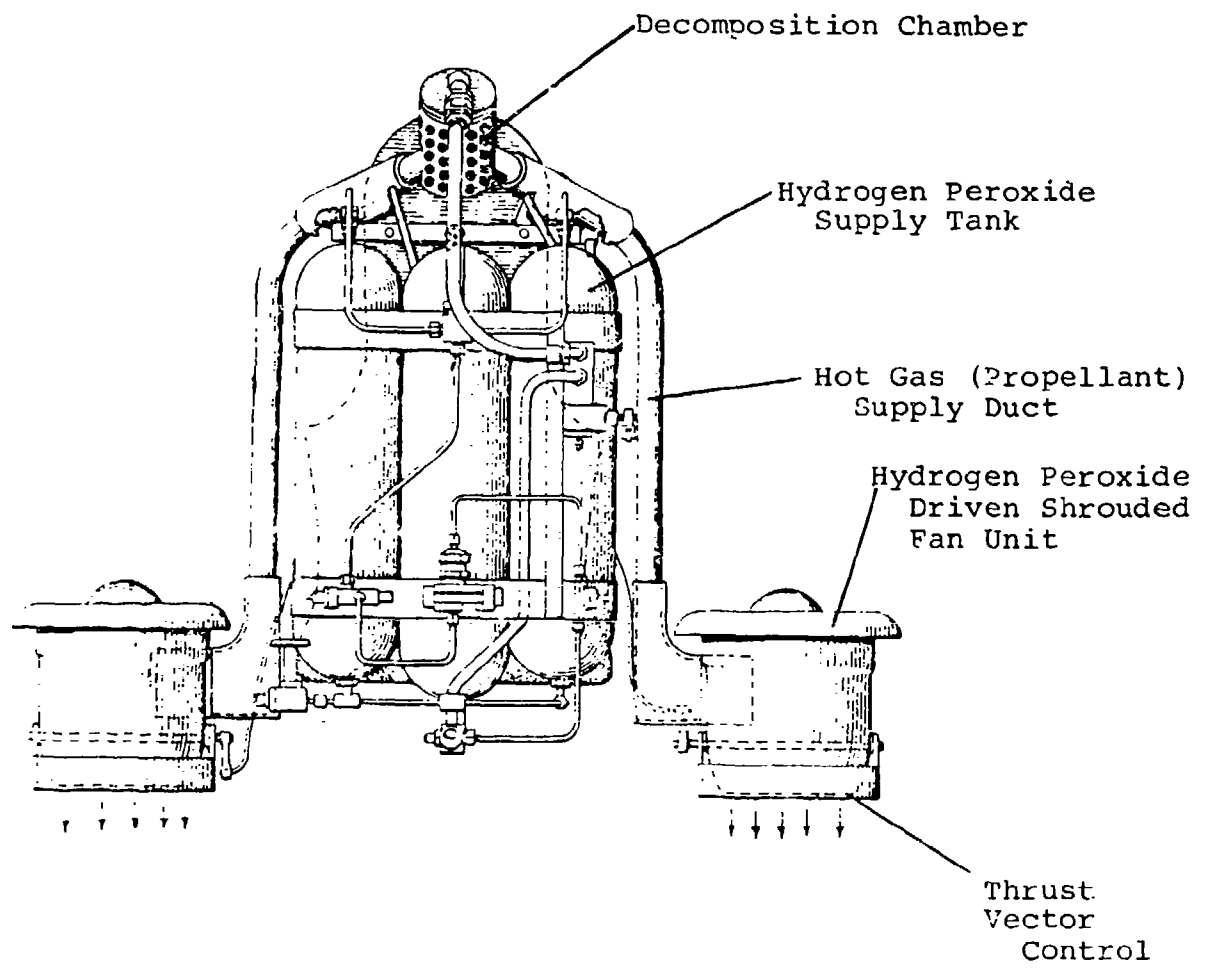
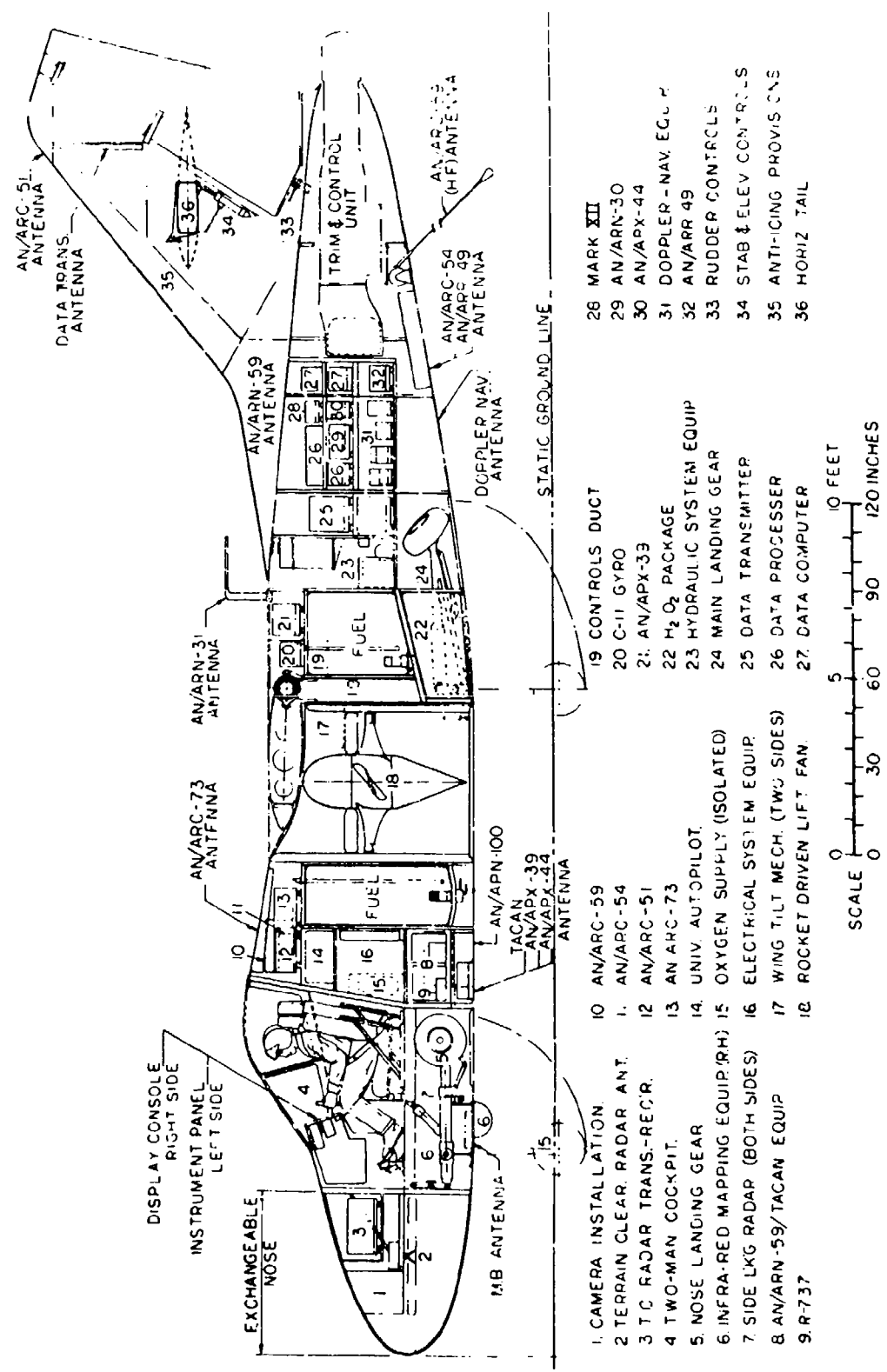

Figure 2.3.1.2 Bell Aerosystems Rocket Belt with Shrouded Fan Thrust Augmentation (from Patent 3,149,799)



Figure 2.3.1.3 Martin Baltimore Model M380-2 Tilt Wing Plus Lift-Fan  
V/STOL Airplane Design (from Reference 2.13)



- |                                |  |                         |
|--------------------------------|--|-------------------------|
| 1. CAMERA INSTALLATION         | 10 AN/ARC-59                             | 26 MARK XII             |
| 2 TERRAIN CLEAR RADAR ANT.     | 11 AN/ARC-54                             | 29 AN/ARN-30            |
| 3 T/C RADAR TRANS.-REC'R.      | 12 AN/ARC-51                             | 30 AN/APX-44            |
| 4 TWO-MAN COCKPIT.             | 13 AN ARC-73                             | 31 DOPPLER-NAV. EQUIP.  |
| 5 NOSE LANDING GEAR            | 14 UNIV. AUTOPILOT.                      | 32 AN/ARR 49            |
| 6 INFRA-RED MAPPING EQUIP.(RH) | 15 OXYGEN SUPPLY (ISOLATED)              | 33 RUDDER CONTROLS      |
| 7 SIDE L'KG RADAR (BOTH SIDES) | 16 ELECTRICAL SYSTEM EQUIP.              | 34 STAB & ELEV CONTROLS |
| 8 AN/ARN-59/TACAN EQUIP        | 17 WING TILT MECH. (TWO SIDES)           | 35 ANTI-CING PROVISONS  |
| 9 R-737                        | 18 ROCKET DRIVEN LIFT FAN.               | 36 HORIZ TAIL           |
|                                | 19 CONTROLS DUCT                         |                         |
|                                | 20 C-11 GYRO                             |                         |
|                                | 21 AN/APX-39                             |                         |
|                                | 22 H <sub>2</sub> O <sub>2</sub> PACKAGE |                         |
|                                | 23 HYDRAULIC SYSTEM EQUIP                |                         |
|                                | 24 MAIN LANDING GEAR                     |                         |
|                                | 25 DATA TRANSMITTER                      |                         |
|                                | 26 DATA PROCESSER                        |                         |
|                                | 27 DATA COMPUTER                         |                         |

Figure 2.3.1.4 Inboard Profile of Martin Baltimore Model M380-2 V/STOL Aircraft (from Reference 2.13)

### 2.3.2 Sud-Aviation Augmented Thrust Rocket Vehicle, "Ludion" (1964-1968)

Unfortunately, only a modest amount of information was available on this Sud-Aviation project and this is reflected in the following presentation, which is based on References 2.14, 2.15, 2.16 and 2.17.

Early in 1960, a M. Caillette of Sud-Aviation applied for a patent on an individual lift device concept using an augmented thrust rocket system. The concept was given the name "Statodyne" and the vehicle, Figure 2.3.2.1, was called "Ludion" for which the English translation is "Cartesian Diver". Presumably, the name was used because the original concept with the propulsion pack on the operator's back resembled a toy Cartesian Diver in appearance.

A number of uses, both military and civil, were visualized for the device. These were believed to make its development well worth while. During 1964 the French Army became interested in the Sud-Aviation concept and contracted with them to develop a demonstrator vehicle. Responsible for the development were the D.R.M.E.<sup>1</sup> and the E.M.A.T.<sup>2</sup>, organizations of the French government, and the industrial organizations Sud-Aviation, SEPR<sup>3</sup> and Bertin et cie. SEPR, a rocket development organization, handled the rocket system. Bertin, because of their expertise in thrust augmentation systems, was selected to build the thrust augments units and the airframe.

The program objective, initially, was to develop a single, light, compact, improved rocket-powered lift device which could be worn and physically carried by an operator while standing on the ground as done with the Bell Rocket Belt. Apparently, the improvement sought was primarily an increase in system specific impulse over that available with an unaugmented thrust rocket. Improved specific impulse could lead to longer flight duration and range. Additionally, the augmented system would generate much less noise along with lower temperature and velocity of the blast. Figure 2.3.2.1 illustrates the original Ludion approach.

As defined by the Headquarters, E.M.A.T., the individual flight vehicle was to be a jet-powered machine for use in leaping over obstacles. It was to be capable of:

---

<sup>1</sup>D.R.M.E. - Direction des Recherches et des Moyens d'Essais.

<sup>2</sup>E.M.A.T. - Epat Major de L'Armee Terre.

<sup>3</sup>SEPR - Societe de Etude de la Propulsion par Reaction.

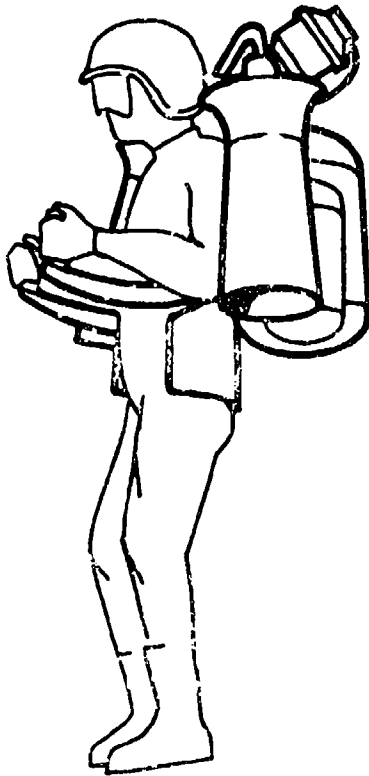
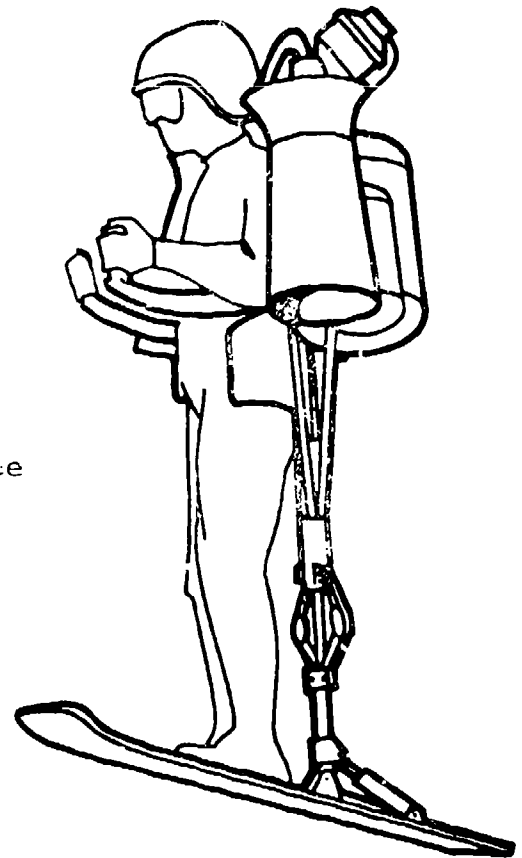

Figure 2.3.2.1 Sud-Aviation  
Original Strap-On  
Augmented Thrust  
Rocket Belt Concept

Figure 2.3.2.2 Sud-Aviation Strap-On  
Augmented Thrust  
Rocket Belt with Shock  
Absorbing Landing Device



(Figures from Reference 2.14)

Military Load (less operator)	at least 30 kg (66 lb)
Maximum speed	over 50 km/hr (31 mph)
Distance	several hundred meters
Altitude	over 50 meters (164 ft)
Total average flying weight target	180 to 200 kg (397 to 441 lbs)

The device was to be easy to handle and trustworthy during take-off and landing.

Weight estimates for the original strap-on configuration (Figure 2.3.2.1) were:

Pilot	80 kg (176 lbs)
Armament (payload)	40 kg (88 lbs) (value selected)
Fuel	30 kg (66 lbs)
Engine & structure	<u>30 kg (66 lbs)</u>
 TOTAL	 180 kg (397 lbs)

Early in 1965 the requirements were reviewed, including the 40 kg payload and it was decided to retain this load. Added to the requirements were take-off and landing with ground speed, and operation from sloping and from rough terrain. Also the takeoffs and landings were to be possible in up to 5 m/sec (16 fps) winds (vertical, horizontal) including crosswinds. A capability to handle a free fall was to be incorporated; the height for this was to be that which would result in a 5 g maximum loading on the operator's body, a value acceptable to the E.M.A.T.

Subsequent study by Sud-Aviation led to the conclusion that the landing speed, vertically or horizontally, should be about 5 m/sec (16.4 fps) and that the free-fall height, to stay below the 5 g acceleration, was 1.5 m (4.9 ft). Further, it was recommended that an emergency landing impact of 10 g be considered, with damage to the apparatus being permitted but without injury to the operator. Free fall height for 10 g was determined to be 3 m (9.8 ft). These additional requirements were accepted by the E.M.A.T.

It was concluded by the E.M.A.T. and Sud-Aviation that a man could not handle a 100 kg (220 lbs) load while landing on his legs and that he would have difficulty even during take-off. A solution based on a skid plus shock absorbing Pogostick-type structure (Figure 2.3.2.2) was considered but discarded because it lacked landing stability.

Sud-Aviation then proposed a seated pilot solution and this was accepted by the D.R.M.E. and the E.M.A.T. The design (Figure 2.3.2.3) included a shock-absorbing landing gear arranged for stability on landing and used a wheel for running on the ground.

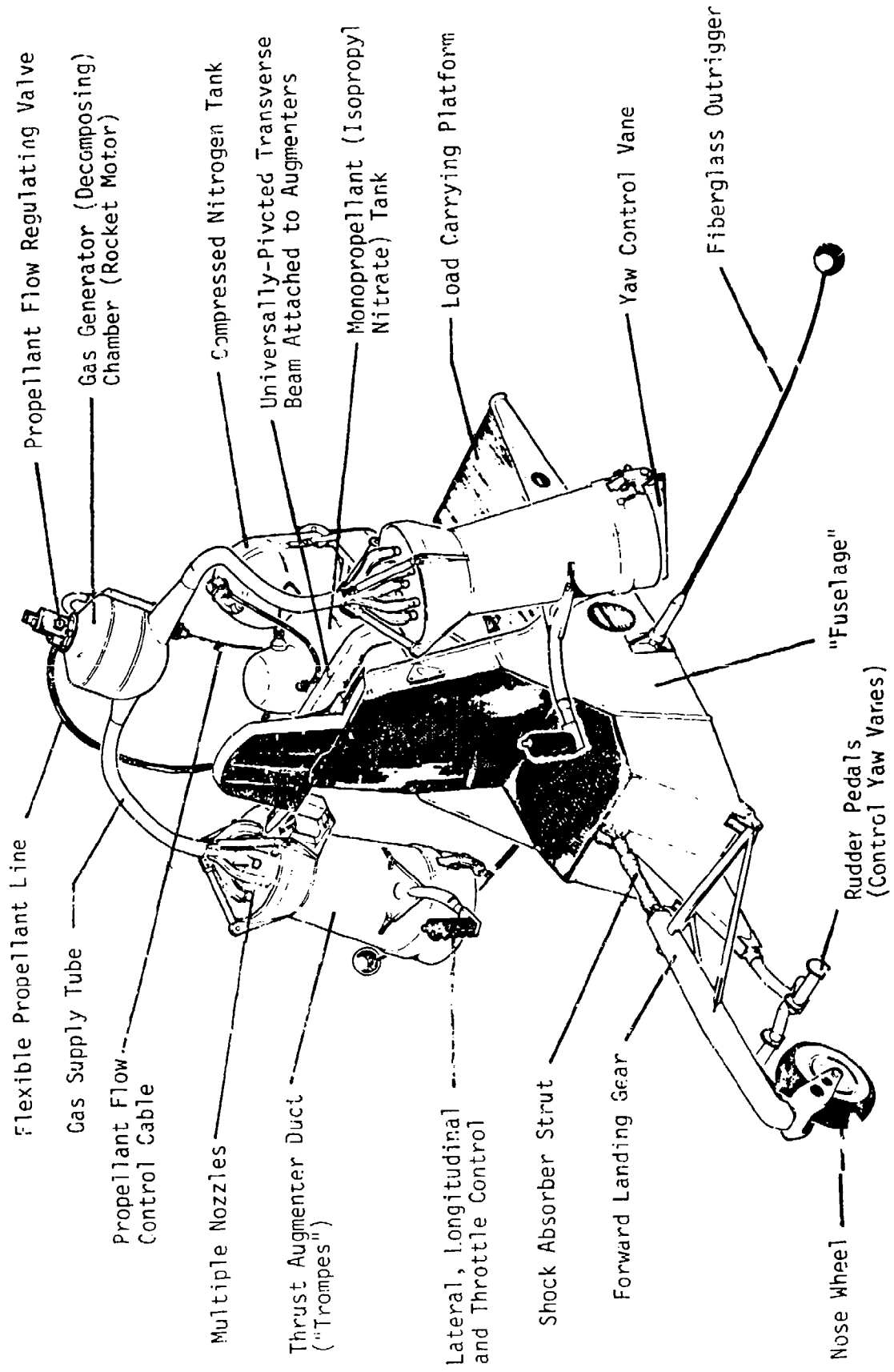

Figure 2.3.2.3 Sub-Aviation "Ludion" Individual Lift Device (from Reference 2.14)  
 (Note: Pilot's controls were changed during construction.)

Prior to building a prototype-demonstrator, Sud-Aviation conducted studies and tests. In 1965 a 4/10 scale model powered by compressed air and using jet ejectors was wind tunnel tested by ONERA<sup>1</sup> at their Chalais-Meudon facility. The results confirmed the theoretical performance predictions. Also in 1965 drop tests on a full-size metal model were performed from various heights and with different horizontal speeds. The data obtained, including slow motion pictures, were used to analyze the landing characteristics and to design the prototype vehicle.

A full size hoverable rig ("simulator") was built. It was powered by compressed air and was provided with characteristics representative of the actual Ludion vehicle (geometry, inertia, thrust, etc.). Testing of this device was done at the Centre d'Essais des Propulseurs de SACLAY during March 1966. The purpose of the testing was:

- To demonstrate the validity of the Ludion flight control concept.
- To train the Ludion pilots.
- To provide a means for studying and improving the man-machine relationships involved in operating a Ludion type device.

During the tests data were obtained on parameters affecting landing characteristics.

The test results having verified the Ludion concept's projected flight capability, the D.R.M.E. authorized Sud-Aviation to build two prototype vehicles. Tethered flight tests (Figure 2.3.2.4) on one of these using four motion-limiting cables were started in February 1968 and showed the vehicle to be readily flyable. In August 1968 the Ludion was operated in semi-free flight at low translational speeds with two safety lines trailing behind. These were held by two men who moved with the vehicle. Figure 2.3.2.5 shows the Ludion in semi-free flight. By October 1968 the machine had accumulated a total of 34 tethered and 12 semi-free flights.

It was concluded that the vehicle had demonstrated good general handling characteristics, high maneuverability and ease of operation in flight, lift-off and landing. Plans called for continued testing including other flight simulator work at the Istre Test Center aimed at verifying the flight behavior over the entire flight spectrum. This was to be done in preparation for flight demonstrations at the 1969 Paris Air Show where two Ludions were to be flown in formation. (The first public static display of the machine, not in flight, had

---

<sup>1</sup>ONERA - Office National de Étude et de Recherches  
Aerospaciales.

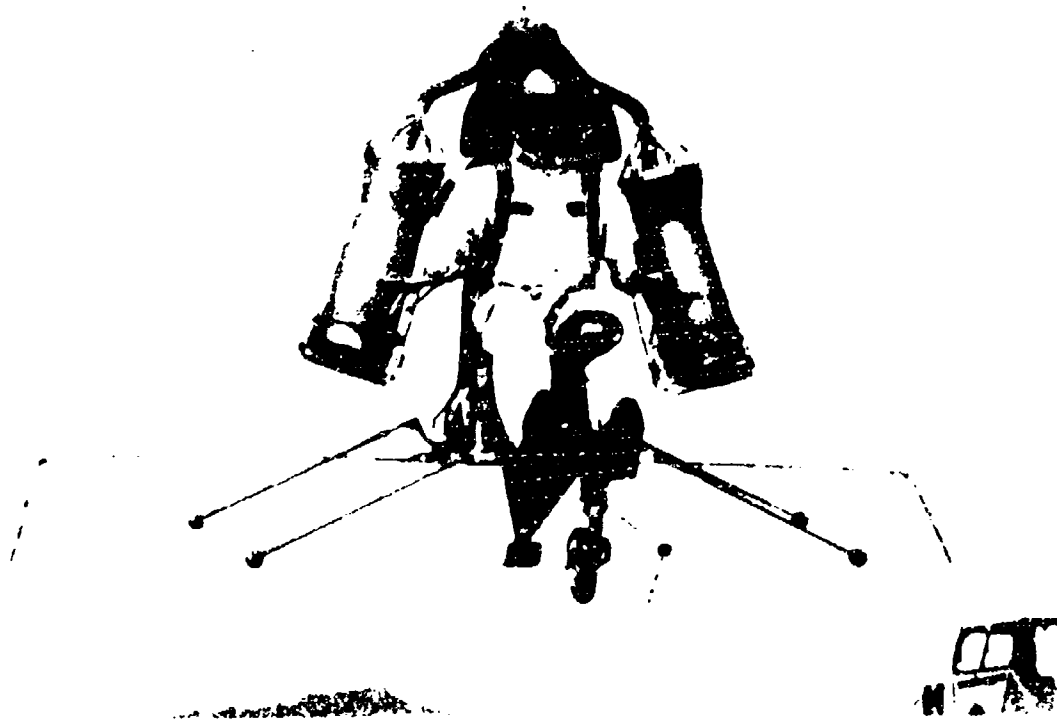

Figure 2.3.2.4 Sud-Aviation Ludion in Tethers' Flight

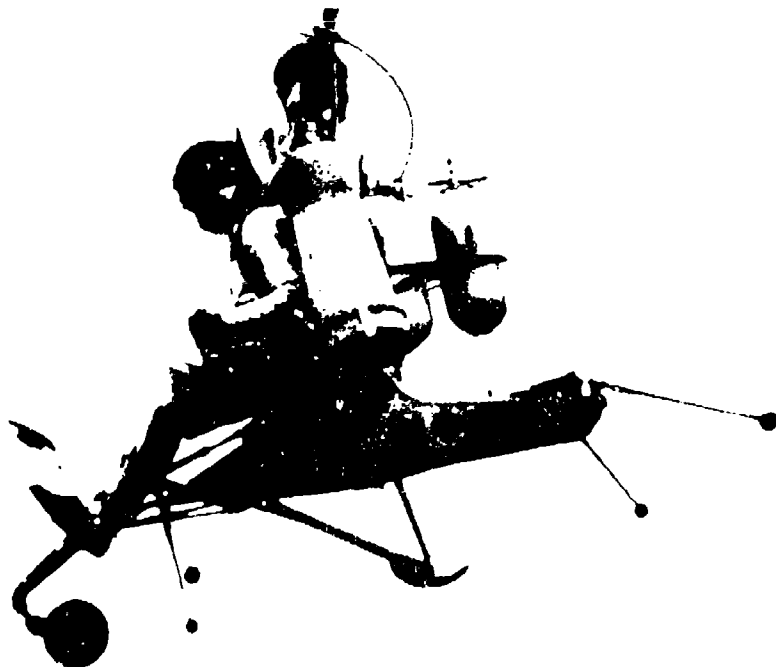

Figure 2.3.2.5 Sud-Aviation Ludion in Free Flight

taken place at the 1967 Paris Air Show.) However, in 1968 the E.M.A.T. decided to discontinue any further development of the Ludion for two primary reasons: (1) the noise, even with 95 db at 1 meter, was unacceptable because it would alert an enemy during military operations, and (2) the 40 second flight duration was too short for a number of the desired uses of the vehicle.

Sud-Aviation subsequently proposed development of turbojet and turbofan direct lift, augmented thrust vehicles based on the general Ludion concept. Figure 3.2.3.4.1 illustrates such an approach as devised by Bertin et cie. The development of such vehicles is believed not to have been undertaken. Of the two Ludions built, one is on display at the Le Bourget Air Museum, Paris, France; the other was destroyed.

Vehicle Design Features: Figure 2.3.2.3 identifies the important components of the Ludion. The basic structure was of light metal alloy with an open seat for the operator in front and a platform for payload in the rear. The landing gear had a single nose wheel mounted on a pivoted arm and used a shock strut to absorb landing loads. Under the "fuselage" (visible in Figure 2.3.2.5) was a single skid with shock absorbing capability. Lateral outriggers of fiberglass were used to keep the vehicle upright. (Originally there were to be two; the actual prototype used four.)

It was planned to incorporate an ejection type parachute for pilot escape during emergencies, such as loss of thrust, when flying above a height of 3 meters (10 ft). Below this height a survivable crash landing was believed possible with the vehicle structure absorbing the impact.

The propulsion system consisted of a single rocket motor chamber (S.E.P.R. S.178 rocket motor), mounted above the c.g., feeding gas through lateral tubes to a set of multiple ejector nozzles. These were located at the entrance of the thrust augmentser and aimed to promote mixing of rocket gas with ambient air. Isopropyl nitrate was used as the propellant and was carried in a cylindrical tank attached to the back of the seat. A second cylindrical tank containing pressurized nitrogen was located aft of the propellant tank. Combustion of the isopropyl nitrate was initiated by an electrical igniter on command by the operator.

The entire propulsion assembly of rocket motor, gas supply tubes, nozzles and augmentser ducts was attached to a transverse beam. This was mounted on a central pivot at the top of the seat back and could move about longitudinally and laterally-oriented axes to permit corresponding tilting of the assembly, thereby vectoring the thrust. Since the pivot was located above the c.g., such tilting produced rolling and pitching moments as well as subsequent lateral and longitudinal translations of the vehicle. Yaw control was provided by

differential motion of transverse vanes at the augmenter duct exits, with control coming from twisting motion of the right hand control stick. (In the original design shown in Figure 2.3.2.3 yaw control was provided by rudder pedals and throttle control was through twisting of the right hand grip. The rudder pedals were eliminated and replaced by foot rests mounted directly on the forward landing gear strut.) The left and right hand control sticks were rigidly attached to the augmenter ducts by arms extending from them; tilting of the propulsion assembly was in response to movements of the operator's arms. Throttle and ignition controls were incorporated into the sticks. Twisting of the left hand grip controlled thrust.

Isopropyl nitrate fuel is a monopropellant which is used industrially in Europe. It has a specific impulse of 179 (at 300 psi chamber pressure), nearly 1-1/2 times that of H<sub>2</sub>O<sub>2</sub>. N-propyl nitrate has very similar characteristics and is used in chemical processes in the United States. These propyl nitrates are relatively easy to handle, have good storability if water entry is prevented, are relatively safe and both the liquid and combustion products have low toxicity. Its cost (1980) is \$0.50 per lb, about the same as H<sub>2</sub>O<sub>2</sub>. However, combustion chamber temperature is higher, 1890°F versus 1370° for H<sub>2</sub>O<sub>2</sub>. If water is present, isopropyl nitrate will produce nitric acid which is corrosive of steel tanks. Ignition of these propyl nitrates must be provided by an outside source.

Sud-Aviation expected a thrust augmentation ratio of 1.5 from the propulsion system. Indications are that this was obtained.

Ludion Weights and Performance: Few data were available. Reference 2.16 contained the following information (except for the estimated numbers).

TABLE 2.3.2.1

CHARACTERISTICS OF SUD-AVIATION LUDION

Weights:	
Operator with personal equipment	80 kg (176 lbs)
Payload	30 kg (66 lbs)
Fuel Weight	39.9 kg (88 lbs)(est.)
Empty Weight	49.9 kg (110 lbs)(est.)
Gross Weight	200 kg (440 lbs)
Specified Performance:	
Takeoff and Landing	Vertical
Max. Speed	Approx. 100 km/hr (62 mph)
Range	Approx. 600 m (1925 ft)
Endurance	Approx. 30 sec.

It is noteworthy that the developed vehicle take-off gross weight was 200 kg or 20 kg (44 lbs) more than the estimated weight of the original strap-on-the-back system. However, to achieve this, the payload was reduced from the originally desired 40 kg to 30 and the endurance was decreased from 40 to 30 seconds. The additional 20 kg (44 lbs) is the cost of providing a seat-type structure and landing gear.

Concluding Observations:

1. The decision that a man could not safely handle a 220 pound load on his back without assistance may be valid. In the case of the Bell Rocket Belt the maximum load on the operator was only 110 lbs (see Table 2.1.2).

2. It is possible that the Pogostick approach (Figure 2.3.2.2) could have solved the problem. Bell's experience absolutely established the reliability of the rocket propulsion system (3000 flights without a single failure) and the ability of the operator to land safely under full control. The E.M.A.T./Sud-Aviation requirement for a 4.9 ft drop height plus 16 fps landing speed appears to be unnecessary. A simpler, lighter airframe than the one finally developed probably could have been used successfully. This conclusion is borne out by the tests on the Bell Rocket Pogo vehicles (Figures 2.2.2.3 and 2.2.2.4) and the Williams Research Company's WASP (covered in Section 3).

3. As far as is known, Sud-Aviation did not consider use of kinesthetic control in any form. Their thrust vector control system, where the entire rocket nozzle-augmenter duct assembly tilted, was simple and straightforward. Sud-Aviation proved that such control worked well and gave the vehicle good flight characteristics.

4. Regarding the propulsion system, the propellant isopropyl nitrate (or n-propyl nitrate) appears to be a good substitute for  $H_2O_2$ . Its 20 percent higher specific impulse could improve rocket-powered system performance. The thrust augmentation ratio of 1.5 is a moderate value for an augmentor system and probably could be increased. It could pay dividends in an individual rocket-lifted system by increasing flight duration and distance or, alternatively, in reducing fuel required, especially if a Pogo-type airframe is used. The endurance/range performance of the  $H_2O_2$  Bell Rocket Belt could have been significantly improved with such an augmentor system.

5. The 95 db noise value achieved at 1 meter also is noteworthy as it is much less than that produced by the Bell Rocket Belt. The main drawback to the Ludion propulsion system is in its increased bulk and space required compared with the Bell Rocket Belt. The increase, however, is moderate and probably would have minor effects on operational use by foot soldiers.

REFERENCES - SECTION 2

- 2.1 Karlheinz Kens and Heinz J. Nowarra, Die Deutschen Flugzeuge 1933-1945, J. F. Lehmanns Verlag Munchen (Germany) publisher, 1977.
- 2.2 "Feasibility Study of Small Rocket Lift Device," Aerojet-General Report No. 1751, Feb. 1960.
- 2.3 P. A. Sollow, "Stability and Control Study of a Small Rocket Lift Device," Aerojet Systems Division, Aerojet-General Corp., July 1960.
- 2.4 C. H. Zimmerman, Paul R. Hill and T. L. Kennedy, "Preliminary Experimental Investigation of the Flight of a Person Supported by a Jet Thrust Device Attached to His Feet," NACA RML52D10, 1953.
- 2.5 W. F. Moore, "Propulsion Unit," U.S. Patent No. 3,021,095, Feb. 13, 1962.
- 2.6 Robert D. Roach, Jr., "Personal Rocket Flight" in Trends in Technology/Rocket Belts, The Penton Publishing Co. (Cleveland, OH), date unknown.
- 2.7 Robert D. Roach, Jr., "Flying All Over the World," Unisphere, a publication of the New York World's Fair 1964-1965 Corporation, 1961.
- 2.8 A. H. Bohr, "Jet Lift Concepts to Improve Individual Soldier-Mobility," Reaction Motors Division, Thiokol Chemical Corp., Report No. TR-737, June 3, 1959 (Proposal to U.S. Army TRECOM in reponse to RFP TC-44-177-59 (Neg-72)).
- 2.9 "Small Rocket Lift Device," Thiokol Chemical Corp., Reaction Motors Division Proposal TR-3262 (Proposal to U.S. Army TRECOM in response to RFP TC-144-177-60 (Neg-25)).
- 2.10 A. H. Bohr, "Rocket Jump Belt--A Proposed Experimental Program," Thiokol Chemical Corp., Reaction Motors Division Report No. TR-3355-1, Aug. 1, 1959 (complements Reference 2.9).
- 2.11 "Airdrop Equipment and Technology (Current and Projected) - Foreign (U)," U.S. Army Materiel Development and Readiness Command, Foreign Science and Technology Center, DST-13505-024-79, Mar. 5, 1979 (CONFIDENTIAL).
- 2.12 Brochure: "The Most Revolutionary Aircraft to Leave the Ground," Aerospace General Company, 2701 East Highway 80, Odessa, TX.

- 2.13 "Surveillance Aircraft System--ASR No. 2-60," Martin Company, Report submitted to U.S. Army in response to ASR No. 2-60 of Dec. 1, 1959 conducted under U.S. Army Transportation Corps Project NR-9-38-10-000.
- 2.14 "Sustentateur Individuel 'Ludion' - Historique," ("Ludion" Individual Air Vehicle-History), Sud-Aviation Suresnes Office, France, Document DTS/S No. 70-081/67, May 1967.
- 2.15 "Sud-Aviation Ludion," Janes All The Worlds Aircraft, 1967/1968, p. 66.
- 2.16 "Sud-Aviation Ludion," Janes All The Worlds Aircraft, 1968/1969, p. 84.
- 2.17 "Sustentateur Individuel Ludion," Sud Aviation - Etablissement de SURESNES, DTS No. 65.235/68-JCP/GMC, Oct. 11, 1968.

## SECTION 3

### VTOL AND V/STOL AIRCRAFT WITH TURBOJET/TURBOFAN PROPULSION

#### 3.1 INTRODUCTION

Turbojet/Turbofan (TJ/TF) aircraft can be divided into two classes: those which rely completely on the propulsion system's thrust for lift in all flight modes (wingless) and those which transfer the lift function to aerodynamic surfaces (wings) after adequate speed is reached. The first type represents special VTOL devices having the characteristics of simplicity, compactness, relatively short range and low flight time. Also, they can have high speed capability. Such vehicles usually are intended to provide improved individual mobility (in a manner similar to the Rocket Belts of Section 2). These wingless aircraft represent a very small part of the total TJ/TF VTOL development effort and are closely related to the lift/cruise-engine-only V/STOL airplane types (Figure 3.1.1). It should be remarked that these wingless types are classified as aircraft because their propulsion systems use the surrounding air mass in generating lift and propulsion. (By the same token, unaugmented thrust rocket vehicles are not classified as aircraft.) Section 3.2 covers the wingless TJ/TF aircraft types.

The other class of TJ/TF VTOL aircraft covers winged vehicles and makes use of a much wider variety of propulsion concepts. These aircraft are aimed at flight operations similar to those performed by their conventional airplane counterparts, e.g. transport, combat, utility, etc. Section 3.3 presents the winged TJ/TF concepts.

As with their conventional airplane counterparts, turbojet and turbofan propulsion is used generally on V/STOL airplanes designed to fly at speeds from about Mach 0.5 to supersonic. For purposes of this document, turbojets and turbofans are considered to be of the same engine family, varying only in by-pass-ratio (BPR) between values of zero and 6.0. As indicated earlier, BPR affects cruise fuel economy and static (vertical) thrust capability (Figure 1.16).

Figure 3.1.2 brings out the basic problem found in most turbojet/turbofan V/STOL aircraft, that of the large disparity between thrust required in conventional mode flight and that needed in VTOL. This disparity is different for the various types of aircraft. Transports and utility type V/STOL

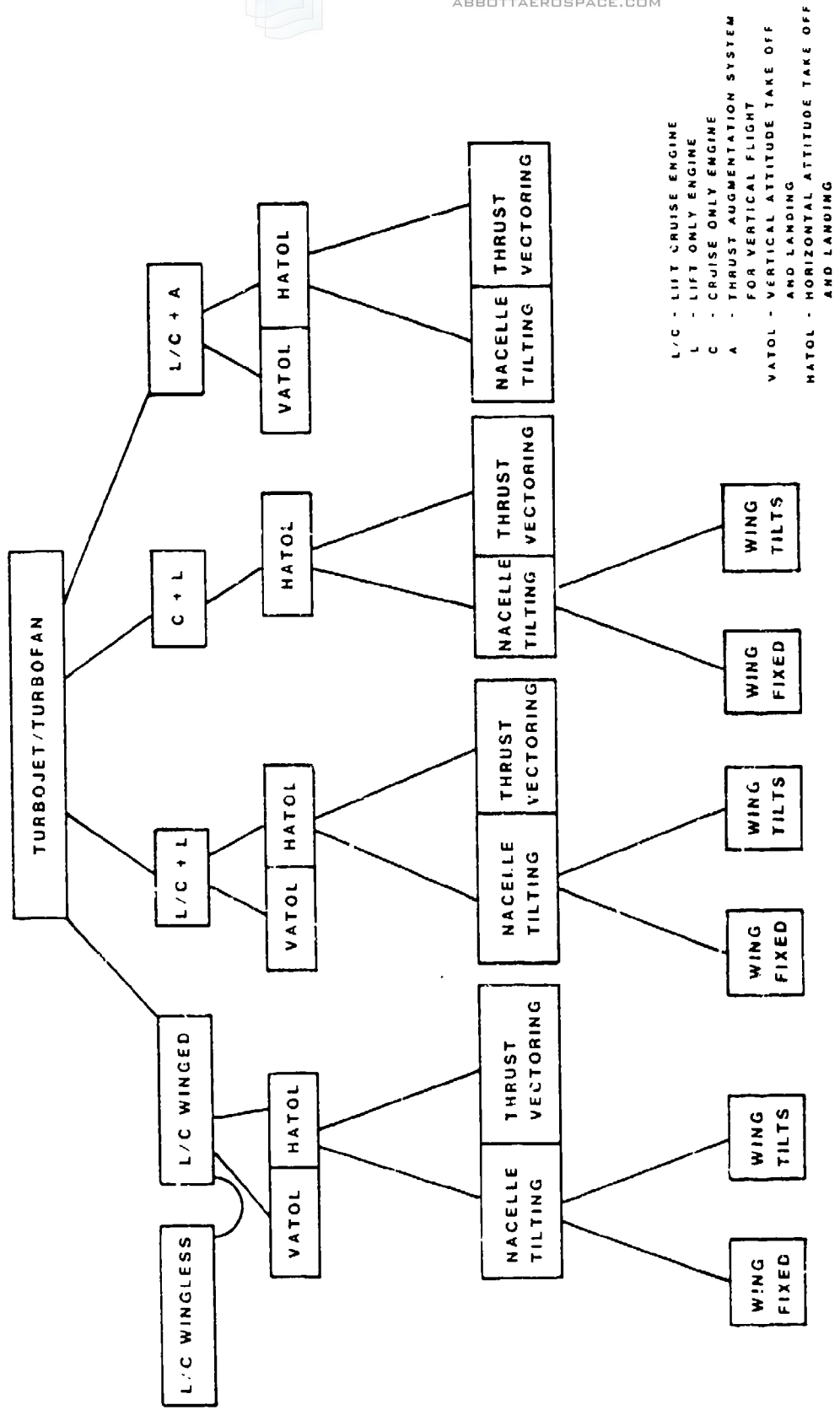

Figure 3.1.1 Categories of Turbojet/Turbofan Propelled VTOL and V/STOL Aircraft

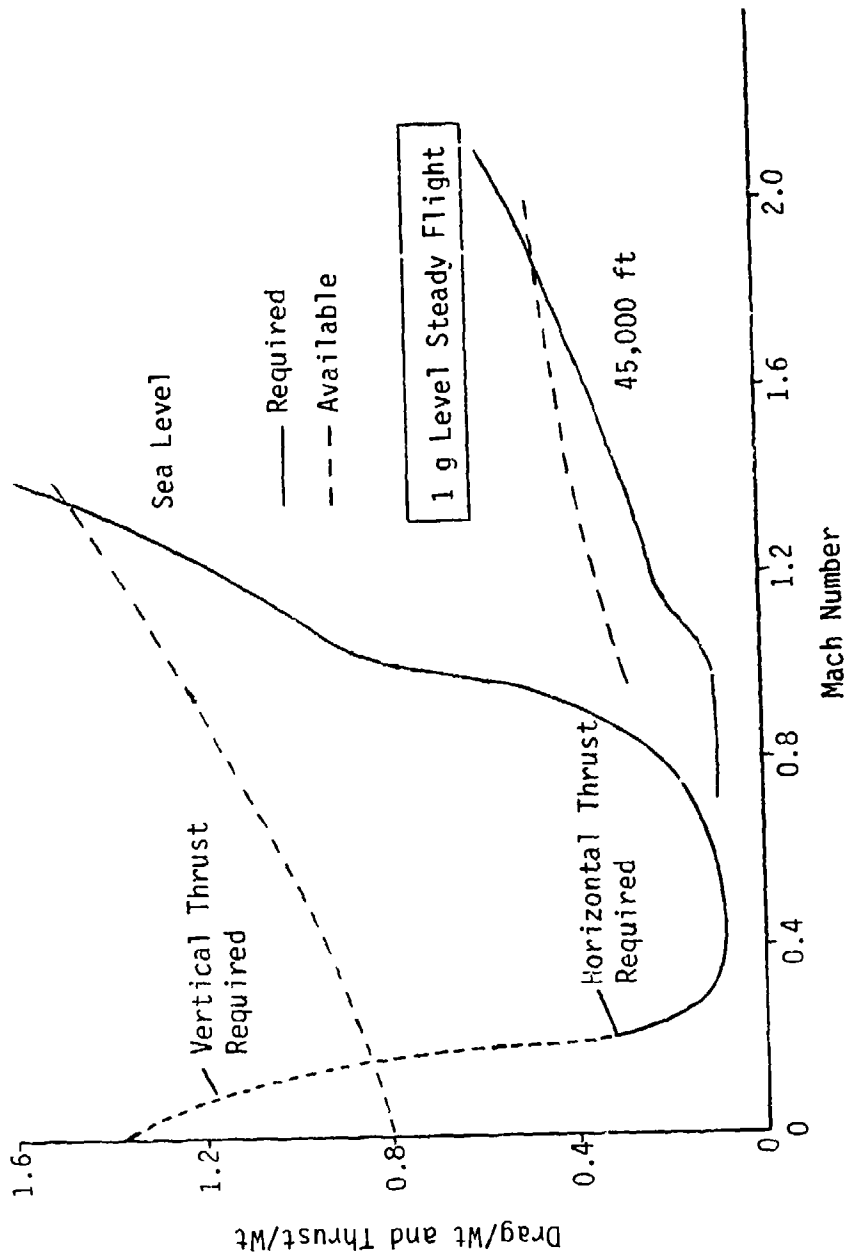

Figure 3.1.2 Thrust Requirements of a VTOL Fighter

machines, for example, have the greatest disparity while air-to-air combat fighters have the least. Primarily, the disparity comes from the conventional flight aerodynamic efficiency of the airplane, defined by its lift-drag ratio ( $L/D$ ). The higher the  $L/D$  the lower is the thrust needed in cruise/high speed flight and the greater is the difference between cruise and VTO/hover thrust. An efficient transport, in cruise, could need only 1/15 to 1/20 or less of the VTO thrust. Of course, the thrust-to-weight ( $T/W$ ) of conventional airplanes is higher than that necessitated by cruise/high-speed flight because of the need to take-off in reasonable distances, climb at satisfactory rates and fly at higher altitudes than those occurring during take-off. Modern supersonic fighters, designed for aerial combat, generally already have  $T/W$ 's greater than 1.0 to give them high maneuverability and do not have, inherently, much disparity. Thrust-to-weights exceeding 1.3 (with afterburning) are found in the F-14, F-15 and F-16. A major problem is how to redirect the engine thrust between VTOL and conventional flight.

Where only the same engine(s) provides all of the thrust in VTOL and in cruise, substantial oversizing of the engine is necessary, compared with an equivalent conventional airplane. The oversizing is aggravated further by the need to provide for flight control, including vertical acceleration, installation losses, suck-down effects, etc. With turbofan systems, the oversizing problem is reduced compared with turbojets, decreasing with increasing by-pass-ratio.

Aside from the extra weight and bulk of the oversized engine(s), which are not unexpected penalties for VTOL, the engines will have substantially higher fuel consumptions in cruise than their conventional airplane counterparts. Current (1970's) turbojet/turbofans operate less efficiently at part power than at cruise power because their thermodynamic cycles cannot efficiently accommodate off-design operation. Variable cycle engine concepts are under consideration and could eliminate this problem at costs of increased complexity and weight but none have been developed to date (1980). The impact on the aircraft of the larger engine and higher fuel load is greater than just the increased weight of these two items because the airframe must grow to accommodate them. Hence, V/STOL aircraft are substantially heavier (and more costly) than their equal-performance conventional counterparts.

Short-take-off (STO), with higher useful loads than possible during VTO, is one method used to reduce the penalty paid for having a VTO-sized propulsion system. STO can be combined with vertical landing (STOVL) to provide improved performance capability for V/STOL aircraft, since the VL weight is usually less than STO weight. However, this is only a partial answer to the problem. Designers still are faced with the challenge of coming up with solutions to reducing the weight and cost penalties inherent in V/STOL aircraft. Various

solutions have been devised and investigated to provide additional thrust during VTOL, above that available from a cruise/high-speed-sized engine. These solutions, along with the L/C approach, can be categorized as shown in Figure 3.1.1 (taken from Figure 1.12) and are:

1. Lift/cruise engine only (L/C)
2. Lift/cruise engine plus lift engine (L/C + L)
3. Cruise only engine plus lift engine (C + L)
4. Lift/cruise engine with thrust augmentation for V/STOL (L/C + A)

The last three categories represent approaches which incorporate means for adding to, or increasing, the thrust available for VTOL. In the third category, the cruise engine is not used to provide any vertical lift at any time.

To clarify the categories, it will be understood that, in the L/C type the TJ/TF engines operate continuously to provide all of the thrust required in all flight modes from vertical to conventional. The addition of lift engines (L/C + L) permits use of smaller L/C engines, sized primarily for cruise/high speed flight and can lead to a more optimum integration of the engines into the airframe. The lift engines operate only during VTOL, transition and STOL while the L/C engines operate continuously. In the C + L, relieving the cruise engines of any vertical lift contribution reduces their complexity, simplifies their installation and operation, and can improve safety during VTOL, but leads to the use of more and/or larger lift engines since they must provide all of the vertical thrust during VTOL. In the fourth category, coupling the L/C engines to thrust augmentation devices (fan, ejector, or remote reheat types) is aimed at sizing the L/C engines for cruise/high speed flight and placing them in a more desirable location within the airframe.

Propulsion combinations exist which do not fall neatly into these categories. For example, the original Fiat G-222 transport conceptual design (Figure 3.1.3) used conventional turboprops without slipstream deflection, and turbojet-lift engines which provided all of the vertical lift. This concept is most logically placed in the third category. Some of Ling-Temco-Vought's "ADAM"<sup>1</sup> conceptual designs (Figure 3.1.3) had a lift fan in the forward fuselage with the fan's primary function being to provide pitch control and longitudinal balance in vertical and transition flight. The fan also produced a small, incidental amount of vertical lift. This

---

<sup>1</sup>ADAM is Vought Corporation's acronym derived from the words Air Deflection And Modulation.

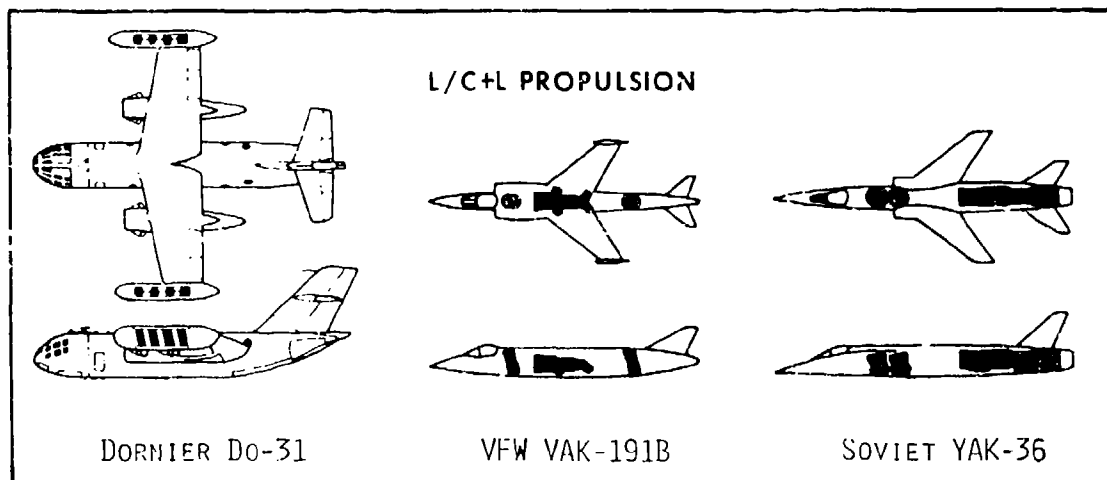
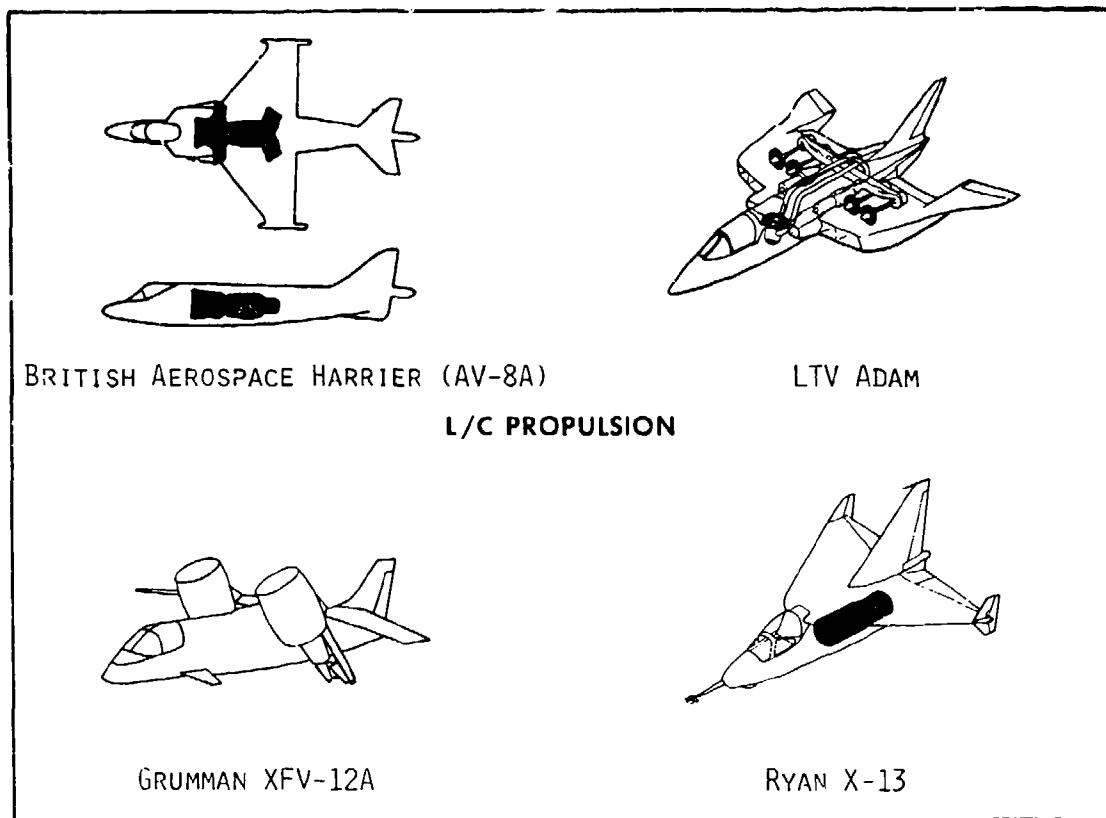

Figure 3.1.3 Representative Propulsion Arrangements for VTOL and V/STOL Aircraft

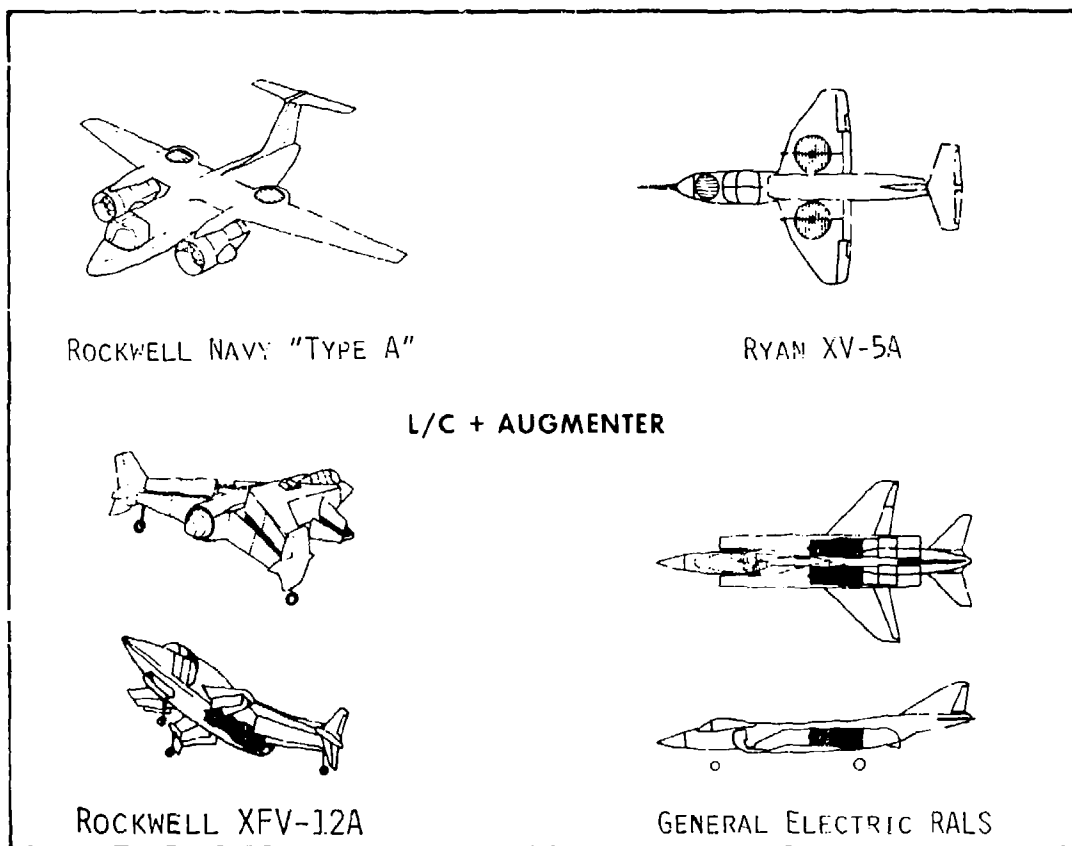
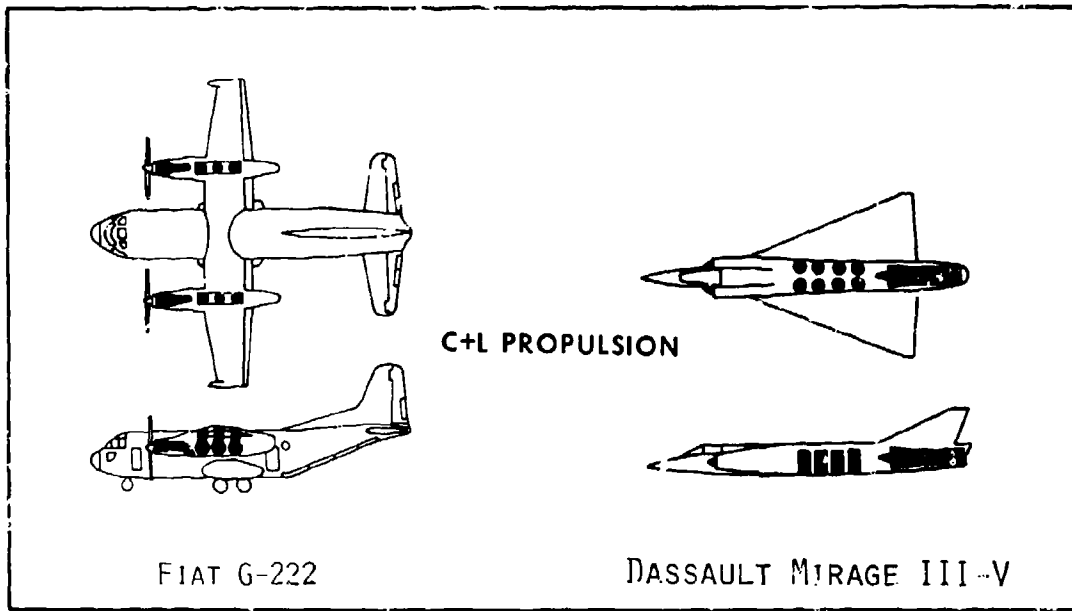

Figure 3.1.3 (Continued)

"ADAM" concept most closely fits into category (1) because nearly all of the vertical lift comes from the cruise propulsion system.

Most of the known turbojet/turbofan-based V/STOL concepts do fall into the four categories readily and a sampling of these concepts is shown in Figure 3.1.3. These are representative examples and do not depict all of the propulsion schemes which have been devised. References 3.1.1, 3.1.2, 3.1.3 and 3.1.4 provide additional information on various V/STOL aircraft which have been built.

Under the L/C category, two level attitude fighter approaches (Harrier and ADAM III) and one vertical attitude (X-13) approach are depicted. Harrier and ADAM represent very different philosophies, the former mounting a four-nozzle vectored thrust engine at the airplane's c.g. and making only a modest effort to use the engine inlet and exhaust airflows to improve airframe aerodynamics in forward flight. The ADAM concept attempted to integrate the turbofan flows fully with the wing (intake in wing leading edge, efflux at wing trailing edge) to provide an effective propulsive wing or propulsive lift system. The VATOL types, as exemplified by the X-13, introduce a minimum number of changes in the power plant to provide vertical flight, but do require special provisions for take-off and landing and for accommodating the pilot's position. In addition, the concept does not favor conventional and STOL mode operations. Another approach found under the turbojet/turbofan category is that of Grumman in their Type "A" design concept where the turbofan units tilt to a vertical position for VTOL.

Two of the L/C + L designs shown are fighter types and differ in the disposition of their engines. To improve vertical and transition flight safety the VAK-191B locates the L/C engine at the airplane's c.g. and places the two lift engines one fore and one aft of the L/C engine. In the YAK-36 the L/C engine is conventionally located in the rear fuselage with its vertical (diverted) thrust force considerably aft of the c.g. Balance is maintained during VTOL flight by mounting the lift engines ahead of the c.g. Safety is compromised to obtain a better supersonic airplane configuration than is possible with the L/C engine mounted at the c.g. Representative of transports which use the L/C + L approach is the Dornier Do-31 on which much effort was expended by the Federal Republic of Germany. In this aircraft, the L/C engines and the sets of lift engines are mounted in separate pods attached to the wings.

---

<sup>1</sup>Type "A" - a Navy classification of V/STOL aircraft for performing various subsonic missions.

The Mirage III V fighter design, representing one of several possible C + L approaches, is based on the belief that a more straightforward V/STOL aircraft can be obtained by completely separating the functions of the engines, using each type only in the job it does best, delivering direct lift or conventional flight thrust. The engine used for conventional mode flight is practically the same as that used in conventional airplanes, including the afterburner, and is mounted in the airframe in a normal way. The lift engines are located around the airplane c.g. and a relatively large number are used. Their quantity is determined by safety considerations concerned with maintaining balance and a high percentage of vertical thrust after failure of one of the lift engines. The other example shown is that of the Fiat G-222, where the cruise thrust is provided by turboprop propulsion units. No use was made of slipstream deflection to add lift during VTOL; Fiat's philosophy was to reduce structural and mechanical complexity as much as possible.

Three approaches to augmenting L/C engine thrust are shown in Figure 3.1.3. In the first, the XFV-12A supersonic fighter, the engine efflux is piped to multiple nozzles located in flow mixing chambers (ejector ducts) where entrainment of the ambient air takes place, increasing mass flow and thrust. The ejectors are located in the wings of the XFV-12A but they can be located in other portions of an airframe such as the fuselage and nacelles. The ejector-augmenter system requires no moving components to produce thrust augmentation. Representing those V/STOL aircraft which use lifting fans to amplify the basic engine thrust, the XV-5A had three such fans, two in the wings and one in the forward fuselage. These were pneumatically driven by engine exhaust gases diverted from the tailpipe to impinge on turbine buckets attached to a ring surrounding the fan blades. The third design shown, a Type "A" aircraft by Rockwell, uses the diverted turbojet exhaust to pneumatically drive lift fans located aft of the wing trailing edge. The lift from these fans amplifies the hot gas thrust and adds to the deflected thrust from the cruise fan in vertical and transition flight plus balancing the aircraft longitudinally.

The third thrust augmentation approach shown is General Electric's Remote Augmented Lift System (RALS) wherein the fan portion of the engine efflux is diverted, via ducting, to another region of the airframe, e.g. the forward fuselage, and the thrust of this flow is increased by adding and burning fuel in the duct. The system shown is that used in an early 1980s supersonic fighter design.

The various T<sub>L</sub>/T<sub>F</sub> propulsion schemes devised represent attempts primarily aimed at solving the thrust disparity problem optimally, the optimum being defined differently by various design groups. Obviously, from the large number of different approaches proposed, there is no consensus on which

is best. Among the many factors normally considered in selecting an optimum concept and aircraft design are:

- Airplane complexity
- Size and acquisition cost
- Life cycle cost
- Development risk
- Propulsion system development required
- Combat effectiveness (fighter); speed, maneuverability, etc.
- Safety in V/STOL and in conventional operation
- STOL capability
- Operational limitations (downwash velocity and temperature, noise)

The most significant concepts and designs are covered in more detail in the following pages. In accordance with the V/STOL aircraft categorization shown in Figure 3.1.1, the first group to be reviewed is the wingless turbojet/turbofan type; these are of the L/C-only propulsion system family. This group is followed by the various airplane types. Table 3.1.1 identifies the aircraft and gives information regarding them.

**TABLE 3.1.1**

**TURBOJET/TURBOFAN AIRCRAFT INCLUDED IN SECTION 3**

Company & Country (if other than US)	Vehicle Designation	Funded by	Operational Mission	Type of Effort	Time Period	Basic Propulsion Concept (Fig. 3.1.1)	Vehicle Concept	Crew + Passengers	Gross Weight (lbs)	
									VTO	STO
dell Aerosystems	Jet Belt	CARPA thru U.S. Army	Individual Troop Mobility	Concept Demo.	1966-69	L/C	Strap-on arrangement	1	400	--
Williams International	WASP I STAMP	U.S. Marine Corps	Individual Troop Mobility	Concept Demo.	1972-74	L/C	Stand-on jet platform	2	580	--
Williams International	WASP II Individual Lift Device	U.S. Army	Individual Troop Mobility	Operat'l Eval.	1978-82	L/C	Stand-on jet platform	1	NA	--
Jarrett Air Search	STAMP	U.S. Marine Corps	Individual Troop Mobility	Concept Demo.	1971-73	L/C	Turbofan powered body with seats	2	975	--
Flight Dynamics Research Corp.	STAMP	U.S. Marine Corps	Individual Troop Mobility	Study & Lab. Research	1974-76	L/C	TJ + ejector thrust augmen. body w/seats	2	no vehicle designed	
Praxair Aircraft	Model 1588 STAMP	U.S. Navy	Individual Troop Mobility	Design Study	1973	L/C	Ducted fan wing using aft with seats	2	1,650	--
Ivan Aeronautical	X-13	U.S. Air Force	Fighter	Concept Demo.	1947-57	L/C	Chin hanger VATO	1	7,350	weight limited to 7,520
SNECMA (France)	C.450 21 Coleopter	Company	Fighter	Concept Demo.	1951-59	L/C	Tail-sitter turbojet wing	1	6,615	capable of VTOL only
U.S. Navy DNASPC	48QN-108A	U.S. Navy	BPR activities	Concept Demo.	1973-77	L/C	Chin hanger VATO	none	563	To be used VTOL only
Temco	39	U.S. Air Force	Fighter	Design Studies	1953-54	L/C	Tail-sitter	1	21,080	Capable of VTOL only
Convair	Convair 774	U.S. Air Force	Fighter	Design Studies	1953	L/C	Tail-sitter	1	23,240	Capable of VTOL only
Lockheed	CL-299-1	U.S. Air Force	Fighter	Design Studies	1954-55	L/C	Chin Hanger	1	20,300	Capable of VTOL only
	CL-235-4	U.S. Air Force	Fighter	Design Studies	1954-55	L/C	Self-erecting tail-sitter	1	19,820	Capable of VTOL only
Ivan Aeronautical	Models 44, 111, 115, 115C	U.S. Air Force	Fighter-Bomber	Design Studies	1954-57	L/C	Chin hanger VATO with L.G.	1	33,740	No STO. L.G. used for ferry only
Focke-Wulf Fed. Rep. of Germany	FW	Company	Fighter	Aircraft design & proposal	1950	L/C	Self-erecting tail-sitter	1	16,450	Capable of VTOL only
Boeing	Sea Control Fighter	Company	Interceptor/Fighter	Aircraft design & proposal	1975-77	L/C	Chin hanger VATO with L.G.	1	18,150	To be used VTOL primarily
Northrop	N365-12	NASA & Navy	Fighter	Design Study	1977-78	L/C	Chin hanger VATO with L.G.	1	30,000	40,000
Boeing	SP-121	NASA & Navy	Fighter	Design Study	1977-78	L/C	Chin hanger VATO with L.G.	1	23,375	33,375
Grumman	Grumman 674 "Natracker"	Company	General purpose-LAMP	Aircraft design & proposal	1971-76	L/C	Winged fuselage, cabin port aft fus VATO, L.G.	2	21,530	23,550

**ABBREVIATIONS USED:**

- ASD Williams Aerial System Platform
- DAAR Defense Advanced Research Projects Agency
- BPR Remotely Piloted Vehicle
- LAMP Light Airborne Multi-Purpose System
- L/C Lift-cruise propulsion approach (The same propulsion system is used for vertical, transition and cruise flight. No additional propulsion system is incorporated.)
- T Turbojet
- TF Turbofan
- TJ Turbojet
- VATO Vertical Altitude Take-Off and Landing
- L.G. Landing Gear
- STO Short Take Off and Landing
- NA Not Available
- BPR By-Pass Ratio

TABLE 3.1.1 (Continued)

Company & Country (if other than US)	Empty Weight (lbs)	Max. Speed kts or Mach No.	Service Ceiling (ft)	Power Plant		Remarks
				Number	Make Model, S.L. Static Thrust, T (lbs)	
Bell Aerosystems	NA	60+	NA	One Williams WR-19 T=430	Wingless strap-on system. Flown successfully w/air excessive for individual to carry.	
Williams International	270	Unknown, see remarks	NA	One Williams WR-19 T=700 (with overtemp)	Wingless platform type vehicle. Not flown in forward flight (60+ kts expected). Hover demonstrations performed.	
Williams International	NA	60+ experienced	NA	One Williams WR-19 T=700	Wingless platform type vehicle. Successfully flown in hover and forward flight. Kinesthetic control.	
Garnett A-Research	790	unknown	unknown	One AiResearch TSE231 turbine driving 34.5" fan, 474 HP	Wingless type vehicle with enclosed body. Turbine driven fan supplied airflow for thrust. Hovered in ground effect only.	
Flight Dynamics Research Corp.	no vehicle designed			One NASA developed TJ engine T=70	Wingless type vehicle. No vehicle designed. Primarily an ejector test program.	
Pieaseck Aircraft	906	80	NA	Two Curtiss-Wright rotating combustion engines, 250 HP ea.	Powered by rotating combustion engines to reduce cost involved due to use of turbines.	
Ryan Aeronautical	5,755	320 test limit	altitude limited to 20,000	One Rolls Royce PA 28.49 Avon T=10,080	Aircraft result of considerable development. Hovered successfully.	
SACMA (France)	4,370	435 test limit	NA	One SNECMA ATAR E-5V T=8,160	C-450.01 not equipped with ramjet. Turbojet thrust only. Hovered successfully. Crashed in 1959 during hover test. Aircraft based on considerable develop- ment effort. Crash due to control malfunction.	
U.S. Navy DINSFDC	467	400	NA	One Teledyne CAE XJ402 T=600	Hovered successfully. Project discontinued due to lack of Navy interest.	
Temp	14,830	NA	60,000	One Allison J-71A with TF & A/B T=26,400	Swept wing configuration instead of more commonly used delta wing.	
Convair	16,060	2.0 @ 53,000'	65,000	One Allison J71A with TF and A/B T=27,700	Configuration similar to Convair's successful XFY-1 propeller airplane except lower fin eliminated.	
Lockheed	12,310	2.09 @ 50,000'	63,000	One Wright TJ32C4 T=24,000	Airplane configuration similar to F-104, conventional planform wing.	
	12,030	2.5 @ 40,000'	63,000	Two GE-184 Modified T.E. T=4A	Canard wing configuration aircraft.	
Ryan Aeronautical	17,570	2.5 @ 62,000	65,000	Two GE-1207A T=4A	Aircraft result of considerable development. Very successful program; 136 flights totalling over 30 hours. Satisfactorily demonstrated feasibility of VAWC concept.	
Focke-Wulf Fed. Rep. of Germany	13,160	NA	NA	Two P&W JTF-10 T=10,500 ea.	Limited amount of information available. Tilting nose. Ingenious undercarriage system for self-erecting capability.	
Boeing	10,950	-2.6 @ 70,000'	73,000	Two GE J-10-GE-100 T=4,900 ea.	Light structural weight due to extensive use of composites and titanium. Tilting nose. Outstanding interceptor performance.	
Northrop	16,650	1.75 @ 27,000'	62,000	Two F&W Adv. Technology Non A/B Engines, T=8,200	One of few VAWC designs to use non-A/B engines.	
Yough	12,730	2.4 @ 50,000'	60,650	Two P&W Adv. Technology Engines T=15,700 ea.	Canard configured aircraft. Compact in size. Very good STOL capability.	
Grumman	14,040	0.87 @ 40,000'	NA	Two GE Advanced TF-34 with 60" fan, High BPR. T=13,900 ea.	Unusual concept. Cabin remained horizontal during VTOL and transition.	

ABBREVIATIONS USED:

- WASP Williams Aerial System Platform
- DARPA Defense Advanced Research Projects Agency
- RPV Remotely Piloted Vehicle
- LAMP/L/C Light Airborne Multi-Purpose System  
(Lift-cruise precision approach (The same propulsion system is used for vertical, transition and cruise flight.  
No additional propulsion system is incorporated.)
- TJ Turbojet
- TF Turbofan
- A/B Afterburner
- VA/TM Vertical Attitude Take-Off and Landing
- L/G Landing Gear
- S.L. Short Take-Off and Landing
- NA Not Available
- BPR By-Pass Ratio

REFERENCES - SECTION 3.1

- 3.1.1 Journal of the American Helicopter Society, Vol. 24-Special, Special V/STOL Aircraft Issue, June 1979.
- 3.1.2 "Vectored Thrust Jet V/STOL--An Evaluation of the Harrier AV-8A and the Pegasus Engine," Rolls-Royce Limited Publication TS 3080, Dec. 1978.
- 3.1.3 "Special V/STOL Directory Issue," Flying Review International, Vol. 19, No. 2, Nov. 1963.
- 3.1.4 "Documentation Fur Die Entwicklung Eines - V/STOL Transporters; Zusammenstellung von Projektideen," Vereinigte Flugtechnische Werke GmbH (date not given).

## 3.2 TURBOJET/TURBOFAN POWERED WINGLESS VEHICLES

### 3.2.1 Introductory Comments

It was inevitable that the high thrust-to-weights of the turbojet (and turbofan) engines, with values of nearly 3.0 even in the 1950's, would lead to their application as vertical lift devices in V/STOL airplanes and in VTOL wingless vehicles. Of the latter, there were essentially two groups: the hover test beds and the aerial mobility vehicles. The first were used to demonstrate the hover capability of associated airplane concepts such as the short SC-1, the Ryan X-13 and the SNECMA coleopter. Such test beds were built in the 1950's by Ryan Aeronautical, Rolls Royce, SNECMA<sup>1</sup> in France and the Soviet Union. To Ryan belongs the credit for being the first to successfully hover a jet engine in free flight. This was done with a remotely controlled test rig on May 31, 1951. The test bed approach to proving the vertical flight capability of proposed V/STOL aircraft became a well-accepted practice and was used in the 1960's and early 1970's by a number of organizations such as Dornier, EWR<sup>2</sup> and VFW<sup>3</sup> in the Federal Republic of Germany, Fiat in Italy and North American Aviation in the U.S. Also included in this group is the Bell Aerosystems Lunar Landing Research Vehicle, Figure 3.2.1.1.

The second group of wingless vehicles are machines aimed at providing functions similar to those of the helicopter but with a less complicated and more compact lifting devices than the lifting rotor. In 1959, Bristol Siddeley proposed the machine shown in Figure 3.2.1.2, dubbed the "Flying Pig" because of its use of the Pegasus (Pg) vectored thrust engine, developed for the Harrier. Most of the wingless concepts proposed, however, were smaller vehicles primarily aimed at providing individual mobility.

Individual mobility through the use of aerial devices has been of persistent interest, an interest which can be expected to continue into the foreseeable future. The concepts considered range from those using rocket propulsion, discussed in Section 2, to turbojet/turbofan thrusters, and to high and low disc loading lifting rotors.

In the turbojet/turbofan area, several groups carried out design studies of such devices starting in the early 1950's, notably Hiller Helicopters (Figure 3.2.1.3), Lockheed, Thiokol and Bell Aerosystems. The latter two were involved in the development of rocket-powered individual mobility systems, discussed earlier in this document; however,

---

<sup>1</sup>SNECMA - Societé Nationale d'Etude et de Construction de Moteur d'Aviation.

<sup>2</sup>EWR - Entwicklungsring Sud.

<sup>3</sup>VFW - Vereinigte Flugtechnischewerke.

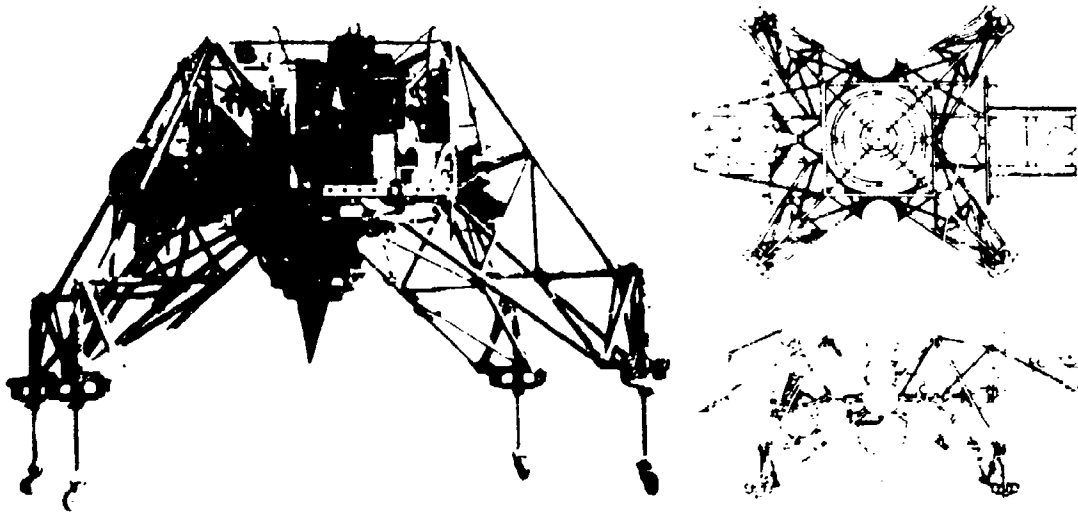

Figure 3.2.1.1 Bell Aerosystems Lunar Landing Research Vehicle (LLRV) (Courtesy Bell Aerosystems Co.)

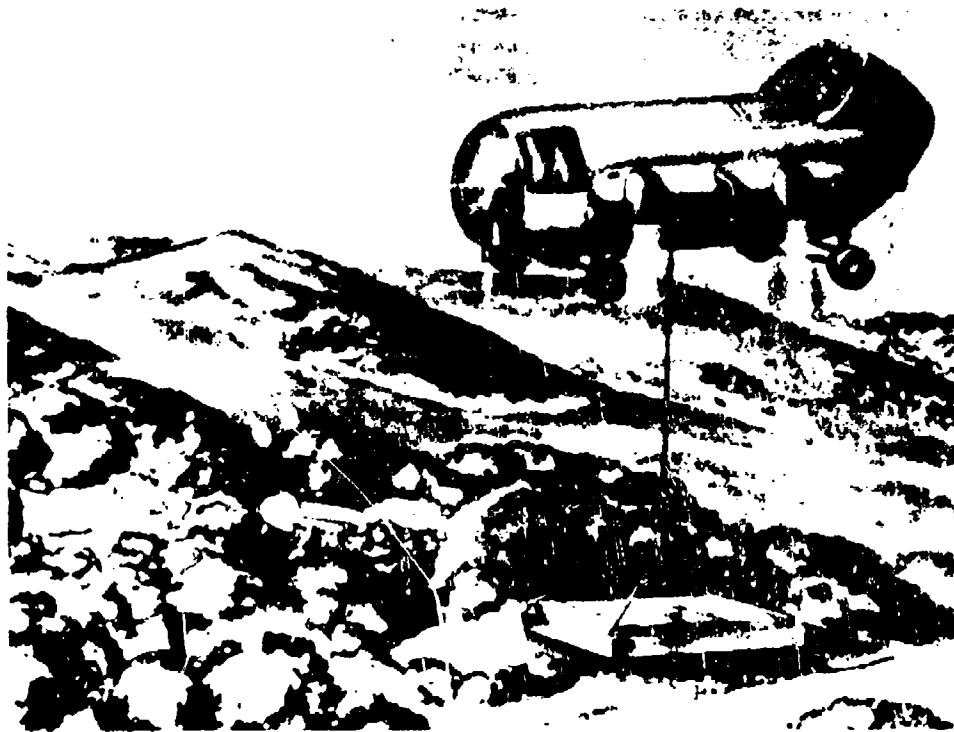

Figure 3.2.1.2 Bristol Siddeley "Flying Pig"  
(from Reference 3.2.1)

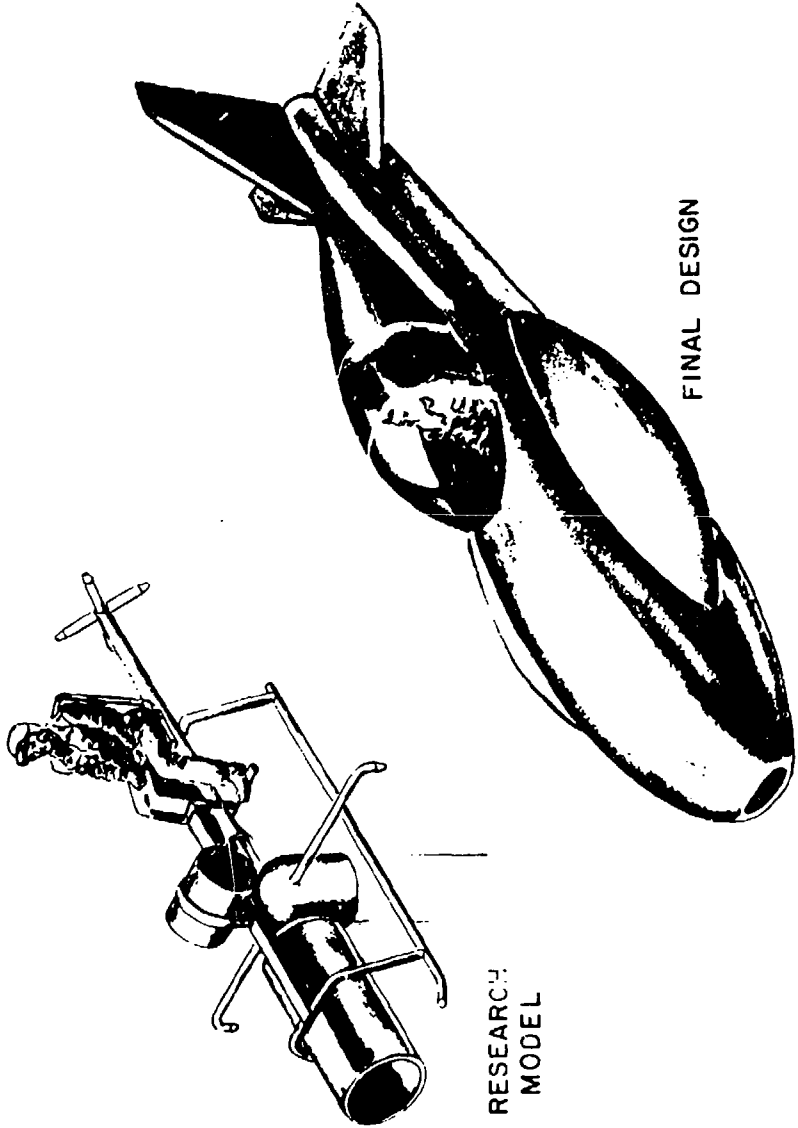

Figure 3.2.1.3 Hiller Helicopters Proposed Turbojet Lift Wingless Vehicle  
(from Reference 3.2.2)

they gravitated toward turbojet/turbofan propulsion because of the much greater durations and ranges possible. Bell carried the transition furthest culminating in a serious development effort.

### 3.2.2 Bell Aerosystems Company Turbojet Individual Mobility Devices (1966-1969)

As with those powered by rockets (described in Section 2), there are three types of individual mobility devices: belts, stand-on platforms and chairs. The idea of using a jet engine to replace the Rocket Belt's propulsion system was conceived during 1964 at Bell Aerosystems by John K. Hulbert, Chief of Gas Turbine Engineering and Wendell F. Moore, Assistant Chief Engineer. Moore is the inventor of the Rocket Belt. Coinventor, with Moore, of the Jet Platform and Chair versions is Edward G. Ganczak, a research associate. On March 29, 1966, Patent No. 3,243,144 was granted to Hulbert and Moore for the Jet Belt. Figure 3.2.2.1 is extracted from the patent.

In 1966 Bell Aerosystems succeeded in interesting both the Defense Department's Advanced Research Projects Agency (DARPA) and the U.S. Army in the Jet Flying Belt concept. During 1966, DARPA provided the funds for the development; this included the engine. The Army Aviation Materiel Command was assigned responsibility for the project and awarded a contract to Bell Aerosystems to build and flight demonstrate a Jet Flying Belt. Because of their unique experience in developing small jet engines, Williams Research Corporation<sup>1</sup> was selected as the subcontractor to develop the Jet Belt engine and \$3,000,000 was allocated to this.

Testing of the Jet Belt commenced in 1967 and the device proved as flyable as the Rocket Belt. Numerous flights were made including demonstrations at U.S. Army bases. Figure 3.2.2.2 shows the Bell Jet Belt in flight. Bell elected to keep the total weight of the Jet Belt at the same value as the Rocket Belt (110 lbs), to avoid overloading the operator on the ground. Consequently, fuel was limited to approximately 25 lbs, giving flight durations of less than 10 minutes, however, this could have been readily increased. Speeds of the order of 60 mph were demonstrated.

During this development and the earlier Rocket Belt effort, Bell Aerosystems held a strong belief in the potential of individual mobility devices, visualizing many military and civil uses for them. Some of the military uses considered were: reconnaissance, counter guerrilla activities, aerial launch of small anti-armor rockets, mine field clearance, rapid telephone wire laying, base perimeter security,

---

<sup>1</sup>Name changed to Williams International in July 1981.

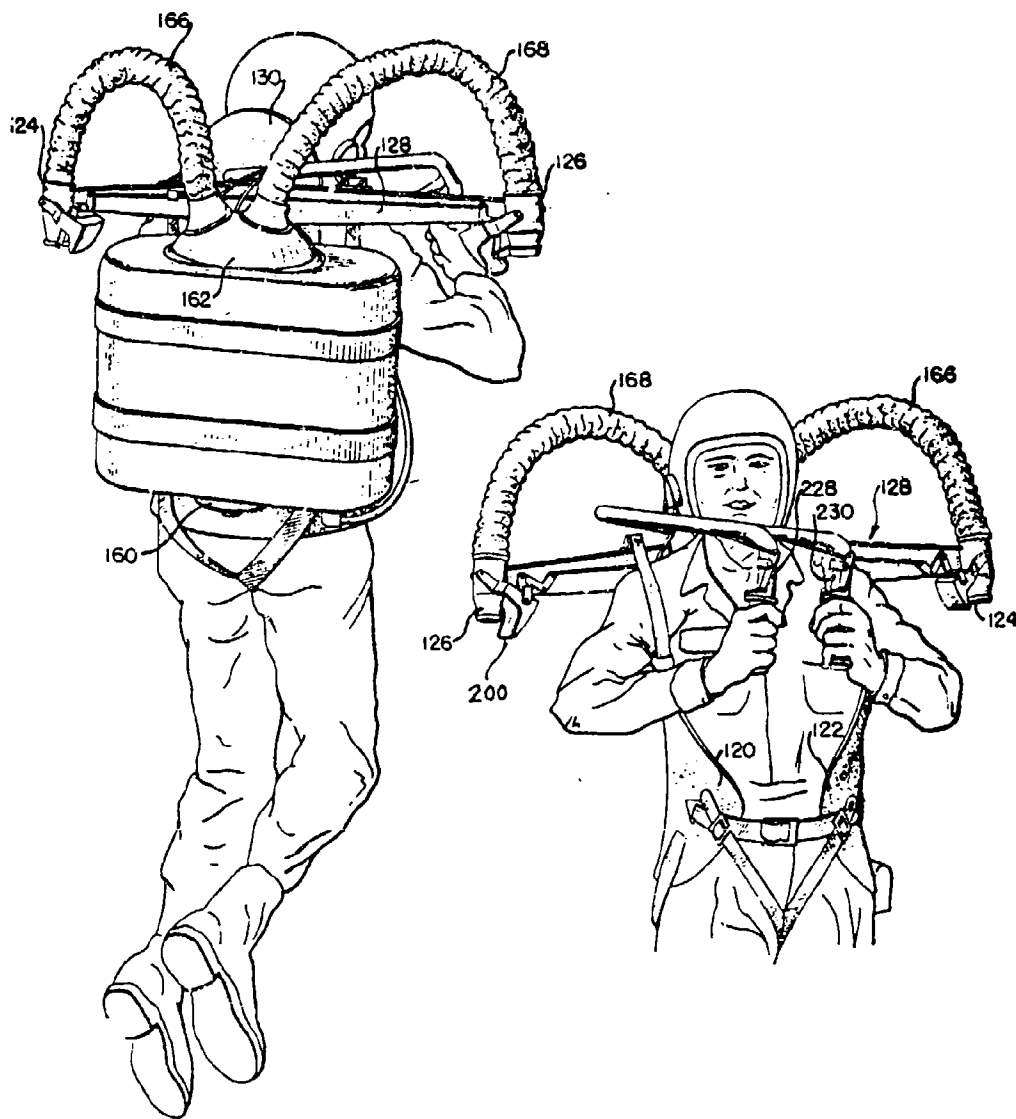

- 120, 122 Corset
- 124, 126 Fixed Nozzles
- 128 Cross Arm Assembly Pivoted on 130
- 130 Corset Extension
- 160 Turbojet Inlet
- 162 Turbojet Outlet
- 166, 168 Flexible Ducts
- 200 Flow Deflector
- 228, 230 Control Handles

Figure 3.2.2.1 Jet Belt Patent (No. 3,243,144) issued to John K. Hulbert (Bell Aerosystems) on March 29, 1966



Figure 3.2.2.2 Bell Aerosystems Jet Belt System in Flight  
(Courtesy Bell Aerosystems Company)

artillery spotting, target acquisition, Navy ship-to-ship and ship-to-shore activities, and rescue operations. Civil uses ranged from police activities, fire fighting, emergency medical and rescue, to power line and other facility inspection. Bell Aerosystems believed, further, that the jet-lifted approach had significant advantages over small helicopter type individual lift devices in compactness and in low response to gusts and turbulence. Compactness would permit operations in constrained areas, not possible with a helicopter. Low gust response was considered to be particularly important when operating near buildings, forest and other type fires or under windy conditions in confined areas.

Despite the initial enthusiasm, after completion of the Army contract, Bell Aerosystems reevaluated the potential of the Jet Belt and concluded that its use by the Army would be limited because of cost and maintainability problems in the field. Further, the device was essentially a turbine engine which they believed could be best produced and marketed by an engine manufacturer. Bell Aerosystems decided not to pursue such devices further and offered the license rights to Williams Research.

Williams Research believed then, and continues to believe (1985), that such devices do have a good potential; they purchased the license rights from Bell Aerosystems on January 23, 1970. The development effort has been continued by Williams Research (Williams International), first, through the Marine Corps STAMP (Small Tactical Air Mobility Platform) program and, during 1982-83, with the Army's Tank Research and Development Command.

A chronology of Bell Aerosystems Jet Belt development is given in the following table, which is, in effect, an extension of Table 2.2.2.1 presented in Section 2.

TABLE 3.2.2.1

CHRONOLOGY OF BELL AEROSYSTEMS JET BELT DEVELOPMENT

1964

Jet Belt conceived by John K. Hulbert and Wendell F. Moore  
Jet Platform and Jet Seat conceived by Wendell F. Moore and Edward G. Ganczak  
Patent application made on Jet Belt (July 17)  
Patent application made on Jet Platform and Jet Seat  
DARPA provided funding of Jet Belt development  
Contract given to Bell Aerosystems by Army Aviation Materiel Command

1966

Subcontract let to Williams Research for jet engine  
First ground test of Jet Belt  
First free flight of Jet Belt  
Contract completed and closed out

1970

Williams International acquired license for jet lift devices from Bell Aerosystems (January 23)

Characteristics of the Jet Belt: Bell Aerosystems and the Army established the following requirements for the design of the Jet Belt.

1. Be rugged and simple.
2. Have quick reaction capability.
3. Be man-transportable.
4. Be sufficiently compact to permit easy transport of a number of units using conventional Army vehicles (trucks, jeeps, etc.)
5. Require a minimum of maintenance.
6. Be self-sufficient in the field, requiring a minimum of external support equipment for operation.
7. Not require an external check-out cart.
8. Have a self-contained starting system.
9. Be capable of using fuel supplied via Jerry cans.
10. Use inexpensive, expendable fuel tanks.
11. Use simple, light-airplane type controls.
12. Use an integral ground stand.
13. Be capable of having its engine quickly replaced.
14. Require no special tools for disassembly.
15. Be equipped with an emergency let-down system.
16. Have a built-in radio communications system.

Figure 3.2.2.1 identifies the primary elements of the Jet Belt and Figure 3.2.2.3 shows the developed system. The Jet Belt was essentially similar to Bell Aerosystems' Rocket Belt in principle and arrangement using twin, laterally disposed, tiltable nozzles for lift and control. As with the rocket type, the Jet Belt was attached to the operator's back via a body-contoured corset and harness system. A stand was incorporated to support the Jet Belt unit on the ground and to make it easy for the operator to attach or detach himself from the corset. Vertical movement (retraction) of the stand was to be used to eliminate interference with the operator's body movements during flight and landing. The general arrangement drawing, Figure 3.2.2.3d, shows the stand in retracted position.

As with the Rocket Belt, the corset and harness were designed to transfer the system's weight to the operator's hips when he was standing on the ground; the lift loads, in flight, were carried by his thighs and buttocks through the lower straps. The engine was attached to the back of the corset with the air intake facing downward and the engine flow, the bypass air mixed with turbine exhaust, was delivered by twin ducts to the nozzles. This involved an 180° redirection of the engine flow. The ducts were supported by a transverse beam which was an integral part of the corset, all built of fiberglass. The bifurcated ducts were of stainless steel and

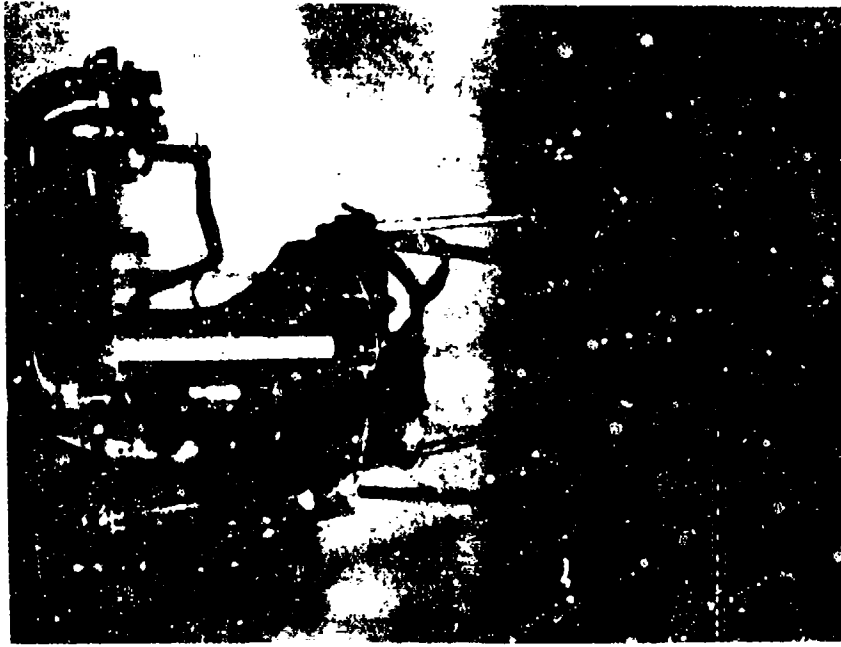

(b) Rear View, on Stand

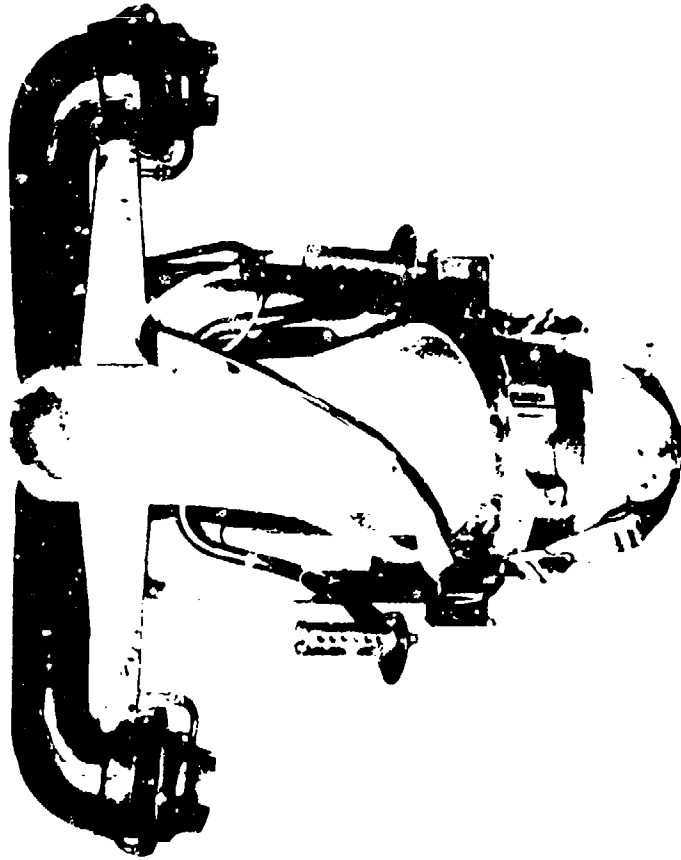

(a) Front View

Figure 3.2.2.3 Bell Aerosystems Jet Flying Belt (Courtesy of Bell Aerosystems Company)



(c) Ready for Flight

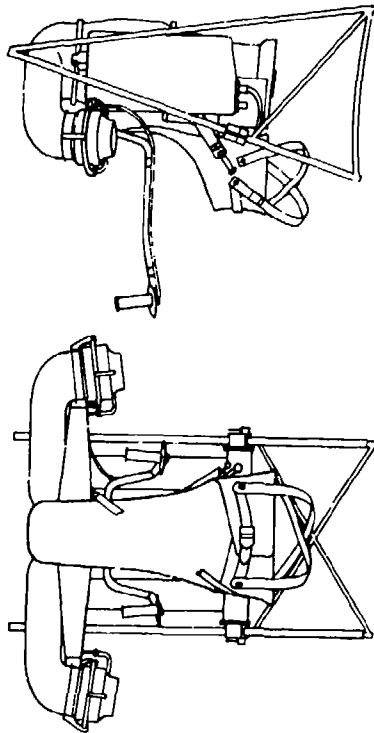

(d) General Arrangement

Figure 3.2.2.3 (continued)

attached to the engine tailpipe with a single marmon clamp to permit easy, quick removal of the engine without special tools.

Twin, interconnected fuel tanks were attached to the corset at each side and were made of clear plastic to permit the operator to visually check the fuel level. In addition, a helmet-mounted buzzer warned the flyer when the fuel reached a predetermined level; a float type detector, located in the left tank, provided the signal. A built-in fuel filter in the filler tube, located on the right hand tank, permitted refueling in-the-field from standard Jerry cans.

Flight weight (gross weight) was approximately 400 lb and engine thrust was 430 lb (S.L. Std. Day).

Control Systems: The control method was derived directly from the Rocket Belt, a method using thrust vectoring and modulation. The twin nozzles, located above the system c.g., were universally gimballed to provide the vectoring. This was obtained by mounting the nozzles on trunnions and using bellows to connect the nozzles to the ducts. Simultaneous fore-aft nozzle tilting produced pitching motion control and translational flight while differential fore-aft movement caused yawing torque and flight direction change. Lateral tilting provided roll control and lateral translation. Coordinated turns in forward flight were made by proper use of hand controls. The operator controlled the system through use of two handlebar grips located at the ends of tubular control arms pivotally attached to the transverse beam, passing under his armpits and mechanically linked to the nozzles. Up-down movement of the control arms tilted the nozzles simultaneously fore and aft; twisting of the left grip moved them differentially. Lateral nozzle movement was produced by a rolling motion of the two control arms and throttle control was provided by twisting the right hand grip. No artificial stabilization devices were used. Prior to flight testing, an analog simulation was conducted to evaluate controllability including gyroscopic effects of the engine (see Figure 2.2.2.11).

WR-19 Engine: Under its contract with Bell, Williams Research built two prototype engines. Designed primarily for the Jet Belt, the WR-19 engine was a turbofan type, the turbofan approach being selected to provide cooler efflux, lower fuel consumption and less operating noise than a pure turbojet. (This engine since then has been used as the basis for the 600 lb thrust class cruise missile engine.)

Figure 3.2.2.4 shows the actual engine; the sectional illustration identifies its major features. (Not shown is the system for spraying fuel into the annular combustion chamber via a revolving slinger on the shaft between the centrifugal compressor and high pressure turbine.) Significant features of this turbofan are the use of the fan air, flowing

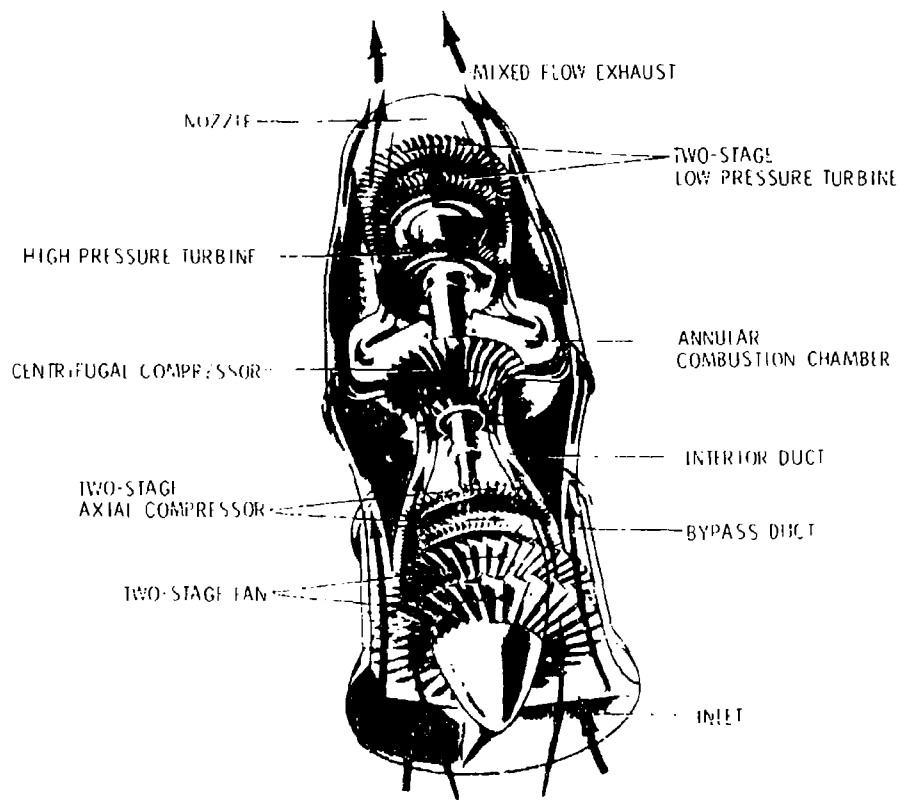
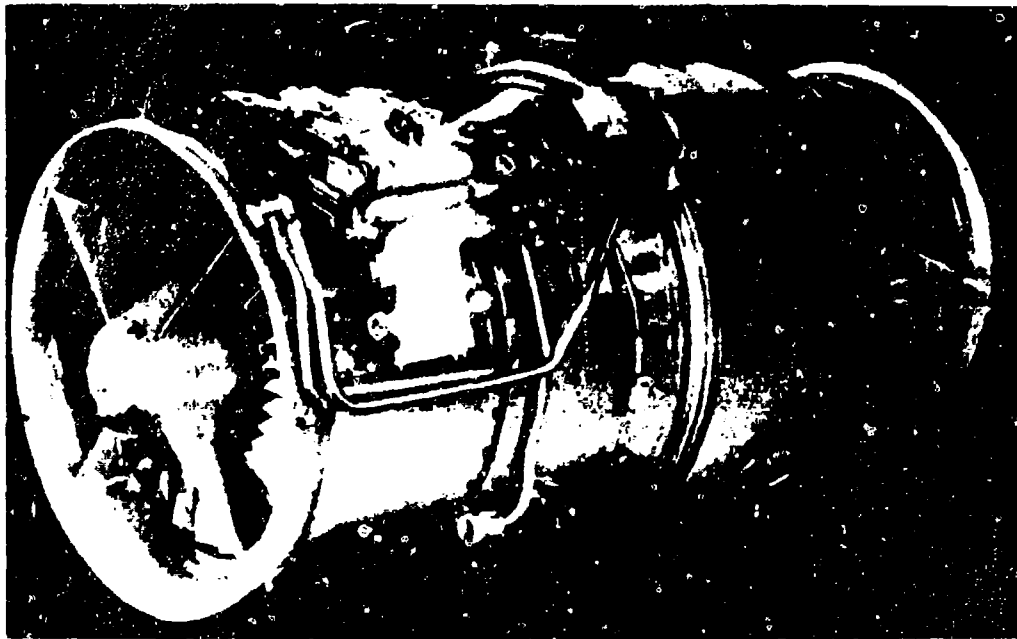

Figure 3.2.2.4 Williams Research WR-19 Turbofan Engine  
(Courtesy Aviation Week)

through the bypass duct, to keep the outside of the engine cool and the opposite rotation of its two spools. This feature reduced gyroscopic effects during flight. The characteristics of this engine are given in Table 3.2.2.2.

TABLE 3.2.2.2

CHARACTERISTICS OF WILLIAMS RESEARCH WR-19 ENGINE  
 (from Reference 3.2.3)

Thrust	430 lbs
Bypass Ratio	1.0
Diameter	12 inches
Length	24 inches
Dry Weight	57 lbs
Thrust-to-Weight	6.4
Specific Fuel Consumption	0.7 lb/lb thrust/hr
Fuel	JP-4
Starting System	solid propellant cartridge (for spin-up and ignition)
Oil System	non-recirculating

Other Jet Lift Individual Mobility Arrangements:

As pointed out earlier, there are other configurations for individual mobility devices. Figure 3.2.2.5 illustrates some platform types. Two arrangements of a single-place stand-on platform are shown, one with the engine in front of the operator and the other with it behind (as done in the Jet Belt design). To obtain the two-place versions, a second turbofan unit was added to form a twin-engine, four-nozzle propulsion package. Here again, the pilot can be located ahead of, or behind the engines. In the design with a seat, the passenger is the one who is seated but, obviously, the controls could have been placed at this position, permitting the pilot to be seated. No illustrations of a single-place seat-type were available but such a design would resemble the rocket type shown in Figure 2.2.2.5.

Although Bell Aerosystems had flown platform and seat type rocket-powered individual lift devices earlier, their turbofan-powered work was not extended beyond the Lift Belt. Williams Research, in their subsequent efforts, has focused on the stand-on platform arrangement and is currently (1985) using kinesthetic control instead of thrust vector control.

The last figure (3.2.2.6), shows a further evolution of the individual mobility system into a two-place vehicle with a body or cabin, seats and twin turbofan power units. Such designs actually may be closer to lift-cruise type aircraft, covered later, than they are to individual mobility systems. For the design of Figure 3.2.2.6 and the other twin-engine

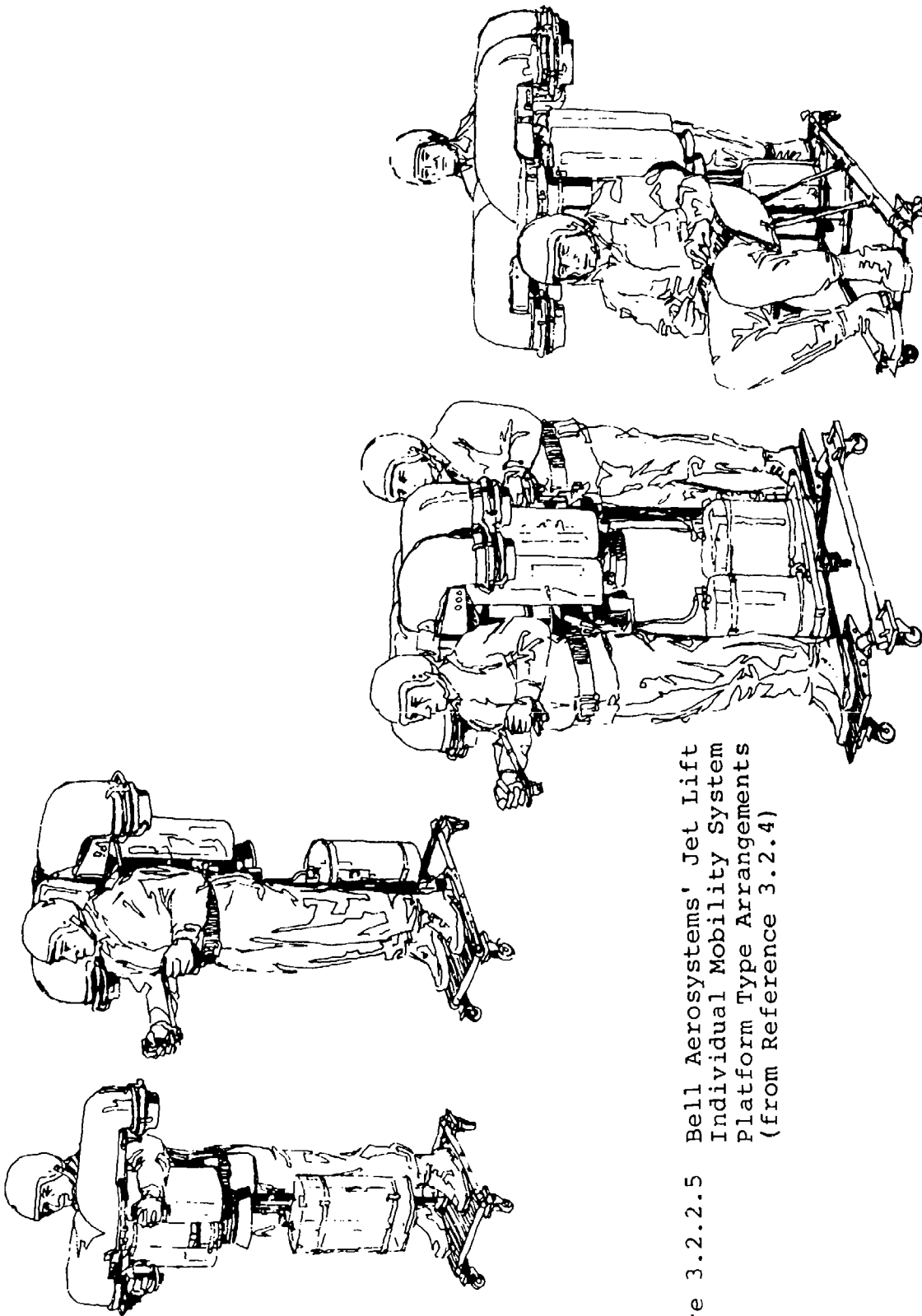

Figure 3.2.2.5 Bell Aerosystems' Jet Lift Individual Mobility System Platform Type Arrangements (from Reference 3.2.4)



Figure 3.2.2.6 Bell Aerosystems Wingless Twin Turbopfan Engine Concept  
(from Reference 3.2.6)

arrangements (Figure 3.2.2.5), engine malfunction considerations are more pressing because of the higher potential for such malfunction compared with a single engine system.

Concluding Observations:

1. With reference to the requirements for the Jet Flying Belt, it is not known how well these were met by the prototype. However, it appears that, with further development of the device and, based on its simplicity, it should have been possible to meet many of the requirements.

2. Because the device, with fuel would weigh over 100 lbs, its ability to meet the man-transportable requirement is questionable. If so, in the choice between the back pack (Jet Belt) approach and the stand-on platform, the latter is preferable. It appears to be less complex and easier for the operator to use. (Williams International has opted for the stand-on platform.)

3. Relatively low cost was not given as a requirement. Considering the intended use of the device, this is an important consideration. Indications are that the turbofan engine itself, suitable for individual mobility, would cost in excess of \$85,000 (1980). To this must be added the other elements, nozzles, controls, fuel tanks, etc. The cost acceptability of the device is an important question and development of a low-cost engine is essential.

4. The engine arrangement, with intake pointing down, was used for compactness and to obtain a low center of gravity. However, when operating near the ground, the intake will be exposed to hot exhaust gases and dust and debris due to the "fountain effect".<sup>1</sup> Reingestion of hot gases reduces thrust; dust and debris, unless filtered out, causes engine damage. It is noteworthy that Williams Research has reversed the engine attitude and placed the intake at the top in their Jet Platform.

5. The approach selected by Bell Aerosystems, of using a turbofan engine with twin ducts and thrust vector control, is generally similar to some lift-cruise VTOL airplane concepts. Kinesthetic control can be used, as proved later by Williams Research, but thrust vector control may be a more powerful and flexible control system. Kinesthetic control, however, reduces vehicle complexity and permits using the hands for other functions than control.

---

<sup>1</sup>Fountain effect is the flow condition produced when two jets in proximity to each other impinge on the ground. The lateral ground flows meet in the center and flow upward.

6. If two engines are to be used to provide a greater lift capability, increased consideration will have to be given to reliability and to the consequences of an engine failure, even if parachute type safety systems are incorporated. Loss of lift, accompanied by tumbling, may make escape difficult. There are exhaust duct arrangements which can minimize or eliminate uncontrollable moments; these should be explored if twin-engine arrangements are to be used.

### 3.2.3 U.S. Marine Corps Small Tactical Aerial Mobility Platform (STAMP) and U.S. Army Individual Lift Device (ILD) Program

#### 3.2.3.1 Introductory Comments

As is already evident from the Rocket and Jet Belt effort previously described, and from other developments such as the deLackner and Hiller platforms (1950-56), the Piasecki and Aerophysics Development "Aerial Jeeps" (1957-58) and the several small, ultralight helicopters (1950-60), there has been a persistent interest in relatively simple, easy-to-operate aerial mobility devices. This interest has been particularly strong in the U.S. Army and Marine Corps. Thus the latter service was highly receptive to a Williams Research<sup>1</sup> proposal, made in 1970, to develop and demonstrate a jet-powered platform. Shortly thereafter, the Small Tactical Air Mobility Platform (STAMP) program was initiated by the Marine Corps leading to the series of events listed in the chronology shown in Table 3.2.3.1. The complete chronological picture is seen by appending Tables 2.2.2.1 and 3.2.2.1 to Table 3.2.3.1. Through 1980 a total of about \$8 million has been spent by the Department of Defense on R&D contracts for the high disc loading mobility devices with about \$5 million being expended between 1970 and 1980 alone. Note, these amounts do not include that spent on the other efforts by deLackner, Hiller, Piasecki, Aerophysics Development and Aerospace General, efforts that were based on relatively low disc-loading rotor-type lift systems.

The latest round of developments, initiated by the Marine Corps in 1971, was followed by the Army's effort on the Williams International Aerial Systems Platform (WASP II) starting in 1978 under the Army Individual Lift Device (ILD) program. This effort is still going on (1983). Army interest in ILD persists internally but no contractor efforts have been undertaken since the end of the WASP II program in 1983.

##### 3.2.3.1.1 Marine Corps STAMP Program:

Initially, the Marine Corps attempted, unsuccessfully, to obtain \$4 million of "emergency funding" from the Department of Defense to develop the Williams Research turbofan-powered concept. Subsequently, the Marine Corps elected to sponsor a more austere program to demonstrate the STAMP flight feasibility under limited test conditions, and, initially, allocated \$500,000 to build a demonstrator vehicle. The Navy, having accepted responsibility for program management, assigned the work to the Naval Weapons Center (NWC) and the technical effort was begun with the preparation of a Proposed Technical Approach (PTA) document along with a NWC technical survey of concepts

<sup>1</sup>Williams Research Corp became Williams International Corp. on June 22, 1981.

TABLE 3.2.3.1

CHRONOLOGY OF MARINE CORPS STAMP AND ARMY ILD PROGRAMS

1969

June Feasibility of Bell Aerosystems Jet Belt demonstrated to Army At Ft. Meyers, Virginia  
 July DARPA/Army-Bell Aerosystems Jet Belt program contract completed

1970

Jan. 23 Williams Research Corporation acquired license rights for Jet Belt/Platform from Bell Aerosystems  
 --- Williams Research Proposed two year development and test program of WASP to U.S. Marine Corps to demonstrate feasibility

1971

Jan. Marine Corps requested \$4 million "Emergency Funding" from DDR&E for Williams Research proposed program  
 May 7 DDR&E denied MC request and suggested MC use their own RDT&E funds to demonstrate Williams Aerial Systems Platform (WASP)  
 Mid MC decided to explore general concept of Small Tactical Air Mobility Platform (STAMP) and to use the "Fly Before Buy/Feasibility Demonstrator Vehicle (FBB/FDV) approach  
 Fall Williams Research made presentations to MC in Quantico and Washington (HQ MC)  
 Dec. 7 MC provided \$50,000 to initiate state-of-art studies by the Navy. Proposed Technical Approach (PTA) document initiated. Responsibility assigned to Naval Weapons Center (NWC), China Lake, California  
 --- MC announced in Commerce Business Daily their interest in STAMP and requested suggestions from industry. 54 suggestions received  
 --- Based on studies made for the PTA, NWC recommended Garrett AiResearch buried (ducted) fan approach  
 --- MC provided \$662,000 for Garrett AiResearch STAMP demonstrator program  
 --- MC asked that Williams Research also be included and provided additional \$500,000

1972

Jan. 22 Marine Corps issued Advanced Development Objective No. MOB-1.04X: STAMP (Small Tactical Aerial Mobility Platform) (CONFIDENTIAL)  
 April TN4008-5 STAMP Operational Concepts, Mission Characteristics and Design Guidelines issued (Reference 3.2.8)  
 --- Army Field Artillery System Review directed. Army to determine potential of rocket belt/aerial platform for field artillery application  
 April Kowalsky/Pitcher TN4008-6 issued. STAMP Survey completed  
 May 3 Garrett AiResearch unsolicited proposal for STAMP vehicle program submitted  
 Sept. 1 Contract given to Williams Research (Contract No. N00123-73-C-0555, \$800,000)  
 Nov. 22 MC and NWC briefed Army R&D organization, Washington on STAMP program, seeking Army financial support  
 Dec. 4 Army unable to financially support program with FY 1974 RDT&E funds. Stated that they would review decision in second quarter FY 1974  
 Dec. 29 Contract to Garrett AiResearch (Contract No. N00123-73-C-1073, \$662,092)  
 --- MC authorized austere development program  
 --- NWC recommended to MC a third approach to STAMP based on use of an ejector to augment thrust of a turbojet engine

1973

Jan. 9 Army Office of Chief of R&D, Washington, instructed Combat Development Command to determine if there was an Army requirement for STAMP and, if so, submit Required Operational Capability (ROC) not later than 2 March, 1973

Mar. 9 NWC was assigned responsibility for development of Canada Jet Diffuser Ejector (C/JDE) for STAMP

Apr. MC issued revision to TN4008-5, STAMP Operational Concepts, Mission Characteristics and Design Guidance (Reference 3.2.9)

--- Army Combat Development Command action

June Garrett delivered STAMP vehicle for testing at El Toro Marine Corps Air Station

June 15 Naval Air Systems Command awarded \$98,000 contract to Piasecki Aircraft to study design of vehicle to meet STAMP requirements using low cost Rotating Combustion (Wankel) engine

July Williams Research performed tethered flight demonstration with one-man (two men required)

--- \$250,000 funds provided for C/JDE investigation

Aug. Letter from Comander NWC to NASC re Coanda Jet Diffuser Ejector

Aug. Exploratory tests on ejector augments conducted by Flight Dynamics Research Corporation

--- \$500,000 made available by Chief, Naval Materiel to explore benefits of C/JDE technology

Sept. Williams Research vehicle made available for two-man testing

Nov. 7 \$127,700 additional funds provided to Garrett

Nov. 21 MC requested Army support to continue STAMP program (no reply received)

Dec. 20-23 Demonstration tests (with safety tether) completed by Garrett

Dec.-Jan. 1974 Two-man demonstration (with safety tether) made by Williams Research

1974

--- Contract given to Flight Dynamics Research Corporation, Van Nuys, California (\$250,000)

Jan. Garrett AiResearch made proposal to Marine Corps to continue STAMP effort addressing important areas such as power plant requirements, vehicle drag, stability, control, surface erosion, etc.

Mar. 5 Contacts made with Navy and Air Force regarding interest in STAMP

June 11 MC finding no support funding for STAMP from Army, Navy, Air Force and being unable to provide funds to continue on a unilateral basis terminated the program. STAMP mobility capability retained as a valid MC requirement

--- Williams Research proposal made to MC to use their WASP to demonstrate and explore MC applications using one-man vehicle

Spring US AAMPDL (at Ames Research Center) made study of vehicles suitable for providing Army with Small Tactical Aerial Reconnaissance System-Visual (STARS-V). Report issued 15 June 1974 (Reference 3.2.10)

1976

Feb. Flight Dynamics Research Laboratory contract completed, report issued Feb. 1976 (Reference 3.2.14)

1977

Feb. Army Training and Doctrine Command gave formal approval to concept of an Individual Lift Device

1978

Sept. 25 Army Tank and Automotive Research and Development Command funded 2-year program to demonstrate the WASP in completely free flight - \$1.582 million (Contr. NO. DAAK-30-78-C0111)

TABLE 3.2.3.1 (Continued)

1980

- Apr. 17 First free manned hover of Williams WASP II, Kinesthetically-controlled vehicle performed
- July 8 Williams Research met all objectives of contract demonstrating effectiveness of kinesthetic control 35-40 mph reached; contract completed

1981

- Sept. Additional funds (1,000,000) provided by Army to get limited airworthiness approval and train two or three non-pilot-rated individuals for testing under a Concept Evaluation Program (Contr. No. DAAE07-81-C-4101)
- Oct. 4 Start of Preliminary Airworthiness Evaluation

1982

- Mar. 9 Completion of Preliminary Airworthiness Evaluation (PAE)
- June Issuance of Final Report on Preliminary Airworthiness Evaluation, Contract completed

1983

- March Contract completed
- May Evaluation of WASP II by 9th Infantry Division at Ft. Lewis, Washington. Vehicle considered not suitable for reconnaissance. No further effort on WASP II considered.

(Reference 3.2.7). This led to a decision to consider other STAMP propulsion concepts as well as that of Williams Research. Inputs for the subsequent review and evaluation were provided by the concepts found among the 54 responses received following a request for suggestions published in an issue of the Commerce Business Daily.

Based on the PTA, the Advanced Aircraft Systems Program Office, Weapons Development Department, NWC prepared a document (Reference 3.2.8), "STAMP Operational Concepts, Mission Characteristics and Design Guidance" for "...the syntheses of suitable technological approaches to the STAMP system."

After entering into negotiations with Williams Research to develop and demonstrate their Jet Platform concept, the NWC recommended exploration of a second concept, a buried fan system proposed by Garrett AiResearch. An additional \$500,000 was added for this purpose. Subsequently, as a result of further studies done by the NWC, they concluded that the most promising approach to STAMP lay in the use of an Ejector Thrust Augmenter approach, leading to the addition of \$250,000 for study and laboratory testing of the Alperin Ejector Thrust Augmenter by the Flight Dynamics Research Corporation. Independently, the Naval Air Systems Command provided Piasecki Aircraft Corporation with \$98,000 to study ducted propeller propulsion concepts for the STAMP based on lower disc loading lift systems and the use of relatively low cost engines, compared with the turbines found in the Garrett, Williams Research and Flight Dynamics Research approaches. Piasecki Aircraft's studies involved reciprocating and Wankel-type engines. During the course of the Garrett and Williams efforts, it was found necessary to add \$250,000 and \$260,000 respectively to each of the contracts. A total of about \$2,178,000 was spent on these four contracts. The following table summarizes information on the contracts.

TABLE 3.2.3.2

CONTRACTS FOR STAMP PROGRAM

Contractor	Williams Research	Garrett AiResearch	Flight Dynamics Research Corp.	Piasecki Aircraft*
Contract Number	N00123-73-C-0555	N00123-73-C-1073	N00123-74-C-0243	N00019-73-C-0519
Date of Contract	Sept. 1, 1972	Dec. 29, 1972	1974	June 15, 1973
Completion Date	Jan. 1974	Dec. 1973	1976	May 15, 1974
Total Contract Funding, \$	1,040,306	789,792	250,000	98,000
Funds Supplied by	MC	MC	MC	Navy (NASC)
Work Required	Flt. Demo.	Flt. Demo.	Study and Lab. Testing	Study Only

\* Note: Not part of the Marine Corps STAMP program. Sponsored solely by the Naval Air Systems Command. NWC and the Marine Corps were not involved.

In accordance with instructions from the Marine Corps, the Naval Weapons Center prepared a technical note (TN), "STAMP - Operational Concepts, Mission Characteristics and Design Guidelines" dated April 1973 (Reference 3.2.9), "...to illuminate conceptual and physical characteristics to guide the synthesis of suitable technological approaches to the STAMP system." This was a revision of a previous TN (Reference 3.2.8) dated April 1972 and incorporated changes made as a result of a comprehensive review of the previous TN by the Marine Corps Development and Education Command. The revised TN reflected the latest (1973) Marine Corps concept of operations for the STAMP system.

Various tasks were projected for the STAMP. These fall into the categories of non-combat support, combat support and combat, covering such activities as: search and rescue, medical assistance, forward air controller, reconnaissance, surveillance, communications assistance, artillery fire direction, laying smoke screen, troop mobility, weapon movement and providing an aerial platform to deliver firepower. An important point made by the Marine Corps was that the STAMP was not to be a replacement for helicopters and motor vehicles but to complement their uses. It was expected to operate in places inaccessible to helicopters and motor vehicles and use routes impassible to them. Because of its small size and expected ruggedness, the STAMP was to be able to fly "...among the tree trunks, beneath the forest canopy, taking advantage of the cover and concealment afforded by the natural environment--actually pushing aside or penetrating frangible vegetation, landing and taking off in spaces too small to accommodate a helicopter even in the absence of barriers to access" (Reference 3.2.8). Table 3.2.3.3, extracted from Reference 3.2.8 gives the target design specifications for the STAMP:

Additional requirements listed below, impacted on the propulsion concept and design of the STAMP.

- Assignment was to be to Marine Corps basic tactical units who would then operate, service and maintain them.
- Training time for operators was to be short. They were not required to have specific prerequisites.
- Servicing and maintenance was to be by regular Marine Corps maintenance personnel (e.g. motor vehicle personnel), not by aircraft mechanics.
- The STAMP was to be deployed uncrated and unpreserved.
- Loading and unloading was to be from trucks, trailers, cargo aircraft and ships.

TABLE 3.2.3.3

TARGET DESIGN SPECIFICATIONS FOR STAMP  
 (from Reference 3.2.8)

Characteristics	Acceptable	Desirable
Payload weight, lb*	450-500	800-850
Payload cube, ft <sup>3</sup>	28-30	38-40
Takeoff and land altitude, ft	3,000-4,000	7,000-10,000
Avg. cruise speed, mph	37-40	71-75
Absolute endurance (in OGE hover), min	30-35	60-65
Range + 10%, miles	16-19	30-53
Task Tools	Fuel gage Map holder Compass Watch FM radio STAMP-helicopter intercom Helicopter hookup In-flight restart Headlight	Diverse special-purpose kits in addition
Safety	Low-fuel warning, emergency descent, push through frangible branches and brush	Extra controllability, heat-resistant materials, headlight, other special-purpose kits
Size	Go between tree trunks beneath forest canopy, land and takeoff in small areas	Land and takeoff on rooftops, in and out of helicopter in flight, proceed below rooftop level
Shape	Push through forest canopy and brush, hook up with helicopter in flight, carry operator plus one	Extravehicular work, carry external load, mount special task equipment on pintle
Flotation		Land and takeoff on smooth water, not entangle lifting sling, land and take-off on small boats, stay afloat on open sea
Noise	Relatively quiet (no physiological damage)	Silent, not trigger acoustic or seismic devices
Erosion	Minimal dust en route to disclose position to enemy	No dust on takeoff and land, no damage to emplaced sensors, no debris to endanger casualty, no melt through rooftops, no damage to external load, no contaminated dust or debris on crew at 10-ft height
Effluents	No visible hot gases, no visible smoke	No trigger sniffers at 500-ft height

\* Payload consists of either an observer, supplies or equipment, and/or fuel in various combinations.

- Stevedoring was to be done manually, by fork-lift or crane. Manual handling was not to require more than three men.
- It was to be transportable via helicopter internally or by external cargo hook. Up to four vehicles to be carried internally by a CH-46 helicopter.
- Actual operation from a helicopter in flight was a consideration.
- The vehicle was to be operationally simple and highly reliable.
- Flights were to be made using visual references primarily; use of standard aircraft instruments (gyro attitude reference, altimeters, rate of climb and airspeed indicators) was to be avoided.
- It had to be capable of retrieving another STAMP vehicle in unloaded condition.
- An emergency descent capability from altitude was required.
- Logistic burden due to the STAMP was to be low.
- It was to use fossil fuels (gasoline, diesel oil) normally available to Marine Corps infantry and combat units.
- The STAMP had to have provisions for two people: the operator and an observer or passenger.

A further important instruction was given in Reference 3.2.8 (page 9) to designers dealing with STAMP concepts. It was stated: "Trade-offs would be inappropriate among size, shape, payload, range, endurance, and obtrusiveness (noise, erosion, effluents, radiation) which degrade the ability of STAMP to do those things motor vehicles and helicopters cannot do, in favor of less relative disadvantage to STAMP in doing things motor vehicles, helicopters can do." The implication was that such characteristics as high downwash velocity and its consequences on ground erosion, high fuel consumption, noise, etc. were not to be used to eliminate any STAMP lift system approaches.

3.2.3.1.2 U.S. Army Individual Lift Device (ILD) Program: Actually, this program is a continuation of the Army's effort to solve the problem of individual aerial mobility which started with the Bell Rocket and Jet Belts. During 1973 the Army attempted preparation of a requirement for such a vehicle but concluded that not enough was known about the ILD system to justify such a requirement. Consequently, a program was started in 1974 aimed at determining the feasibility of such devices. Although the Army participated only to a small extent in the Marine Corps STAMP effort by providing OH-6A fuselages for the Garrett AiResearch vehicle, they did follow the STAMP effort with interest.

In the spring of 1974, the Army's Air Mobility Research and Development Laboratory (AMRDL) at Ames Research Center was given the job of evaluating the "Individual Lift Vehicle" and its problems. Called the Small Tactical Aerial Reconnaissance System-Visual (STARS-V), its required capabilities and uses were to be similar to those of the Marine Corps STAMP and an Initial Operational Capability date of 1981 for the first equipped Army unit was required. An in-house effort was completed by the Advanced Research Office of the AMRDL (Reference 3.2.10) which provided preliminary design information on STARS vehicles based on a variety of vertical lift concepts and configurations: helicopter rotors, large diameter shrouded fans, buried fan-in-fuselage (Garrett), and direct-lift turbofan (Williams Research). Assessments were made of vehicle weight, power, maneuverability, ground erosion characteristics and cost (development, production, operational and 10 year life cycle). Based on their study the AMRDL took the position that, while it was possible to develop a STARS to meet the proposed requirements given enough time and money, its practicality and cost posed serious questions.

Further ILD development by the Army was deferred. However, Williams Research continued to explore the Jet Lift Concept, making use of the STAMP vehicle which had been returned to them by the Marine Corps. Flight control was considerably simplified and a new, higher thrust engine was to be available (derived from the cruise missile program). With these revisions to the STAMP design, Williams was able to rekindle Army interest in the ILD and, in February 1977, the Commanding General (W. E. Depuy) of the Training and Doctrine Command (C.G. TRADOC) formally approved the concept of an ILD. A strong position regarding the nature of the ILD was taken and set forth in a letter from C.G. TRADOC (May 1977) to DCSRDA which contained the following statement:

"We are not looking for a weapons carrier or a load carrying device. We are simply looking for a one man conveyance, without rotor blades, which can move safely in constricted spaces, can communicate by means of FM radio and can be operated by essentially untrained or quickly trained, run-of-the-mill, unit

personnel. If it requires a certified pilot or long training, we are not interested. We would see company executive officers, Battalion S-3, Battalion and Brigade Liaison Officers using these devices for coordination, liaison, battle position reconnaissance, and troop leading."

In this letter the C.G. TRADOC also approved the Williams WASP II as a viable candidate under the ILD concept. The requirement for an ILD appears in the Army Science and Technology Objective Guide (STOG 80-3:15 and 81-3:13).

This formal approval of the ILD started a new effort in 1977 whose goal was, in the words of the Army Training and Doctrine Command, "...to identify a potential candidate that would be readily available, relatively inexpensive, and be a fairly easy to operate conveyance for reconnaissance and troop leading, as well as, liaison and coordination. Once identified, the candidate system was to be made available for use in a Concept Evaluation Program (CEP) of the ILD concept." In 1978 the Army Advanced Concepts Team initiated a program with the Army Aviation Research and Development Command (USA AVRADCOM) to make an Individual Tactical Air Vehicle (ITAV) available for a concept evaluation. This effort with AVRADCOM was not successful and was terminated in January 1979.

Responsibility for ILD research and development management was assigned to TARADCOM<sup>1</sup> by DARCOM<sup>2</sup> on the basis that the ILD was considered to be an extension of land mobility organic to the ground forces and operated by non-rated personnel. Specifically, TARADCOM's Concept Laboratory was given program responsibility. During September 1978 TARADCOM awarded a \$1,580,000 contract to Williams Research in response to their proposal (unsolicited) to demonstrate their WASP-II (Williams Aerial Systems Platform-II). Of this amount, the Army Advanced Concepts Team provided \$944,000.

The Development Efforts: As mentioned earlier, three propulsion approaches were explored under the Marine Corps STAMP program--direct thrust turbofan (Williams), buried fan (Garrett) and ejector thrust augments (Flight Dynamics Research). In addition, the Naval Air Systems Command sponsored a study of the ducted propeller approach (Piasecki). Of these, only the Williams and Garrett efforts were funded through a full-scale, tethered flight demonstration state. The Flight Dynamics Research effort covered only study, analysis and laboratory testing of scale-model components.

---

<sup>1</sup>TARADCOM - Tank and Automotive Research and Development Command

<sup>2</sup>DARCOM - Department of Army Materiel Development and Readiness Command

Piasecki Aircraft's effort was devoted solely to preliminary design studies. The Williams efforts for the Marine Corps and, subsequently, the Army are discussed first.

**3.2.3.2 Williams International WASP I (Marine Corps STAMP) and WASP II (Army ILD)**

The events which brought Williams International into the development efforts with the Marine Corps and Army already have been covered (see Table 3.2.3.1 on Chronology). In essence, Williams became involved in individual lift development in 1966 as a subcontractor to Bell Aerosystems who was working on the Jet Flying Belt under Army contract. Subsequently, in 1970, Williams acquired license rights to the concept and succeeded in interesting the Marine Corps in the possibilities inherent in an ILD, resulting in the STAMP program. This produced a rekindling of Army interest in the ILD, leading to a development, demonstration and concept evaluation effort which was completed in 1983.

Up through 1983, a total of \$7,760,000 has been spent by the Department of Defense on contracted effort to develop the jet lift approach to individual mobility, disregarding the rocket powered efforts. Table 3.2.3.2.1 summarizes information on the contracts involved.

**TABLE 3.2.3.2.1**

**U.S. GOVERNMENT FUNDING OF BELL AND WILLIAMS  
 JET BELT/JET PLATFORM DEVELOPMENT**

Program	Jet Belt Flight Denc.	STAMP Flight Demo (Wasp I)	WASP II Flight Demo	ILD Concept Evaluation Using WASP II
Contractor	Bell Aerosystems	Williams Research	Williams Research <sup>1</sup>	Williams international
Contract Number	DA23-204-AMC-05712(T)	NO0123-73-C-0555	DAA(30-78-C-0111)	DAAE(07-81-C-4101)
Date of Contract	Dec. 30, 1965	Sept. 1, 1972	Sept. 25, 1978	Sept. 1981
Completion Date	June 10, 1969	Jan. 1974	July 8, 1980	Mar. 1983
Total Contract Funding, \$	3,000,000	1,040,306	1,582,000	1,000,000
Funds Supplied by	DARPA	Marine Corps	Army Advanced Concepts Team	Army
Program Managed by	Army (TRECOM)	Navy (Weapons Center)	Army (TACOM, R&D Center)	Army (TACOM, R&D Center)

<sup>1</sup> Name changed to Williams International June 22, 1981.

Without question, individual mobility through use of a jet thrust device has been successfully demonstrated in the strap-on (Bell Aerosystems) and platform approaches. Both thrust vector and kinesthetic control have been shown to be successful methods of controlling the lift device. Williams International has established the technical feasibility of the direct thrust (turbofan) individual lift

platform concept and the validity of kinesthetic control as required by their Army contact. Since the first free, manned hover on April 17, 1980, more than 30 free flights have been made; speeds of 47 mph and durations of about 5-1/2 minutes have been achieved.

Under the Army contract Williams International designed the WASP II vehicle, built two prototypes and completed the required testing using one of the prototypes. Gimbal, tethered and tether-free flight testing was done at the Williams facility (Walled Lake, Michigan) using one of the prototypes. Only minor modifications to the vehicle were made during the flight program and involved a small change in engine nozzle inclination plus the addition of vertical fins to improve directional stability.

Williams International uses the acronym, "WASP" (Williams Aerial Systems Platform) for their individual lift device and the two primary versions have been designated WASP I and WASP II. These are, respectively, the vehicles built for the Marine Corps STAMP and Army ILD programs. Significant differences exist between WASP I and WASP II, primarily in available engine thrust and method of control. the requirements for STAMP and ILD are very similar except that STAMP was intended to carry two people and the ILD is, currently, designed for one person. For both STAMP and ILD the primary missions are observation, reconnaissance, surveillance and laser designation of targets. Both STAMP and ILD requirements included operation in areas inaccessible to ground vehicles and helicopters. The following table compares WASP I and WASP II.

TABLE 3.2.3.2.2.

INFORMATION ON WILLIAMS INTERNATIONAL WASP I AND WASP II

	WASP I	WASP II
No. of places (requirement)	2	1
Uninstalled Engine Thrust, lbs	700	580
Installed Engine Thrust, lbs	620	545
Number of Nozzles	3	1
Air Intake Location	At top of nacelle	At sides of nacelle
Empty Weight, lbs	270	251
Fuel Flow, lbs/min (T.O. wt)	5.3	5.7
Method of Control	Thrust modulation and three nozzles, for pitch & roll. Thrust vectoring for yaw. Engine rpm for altitude.	Kinesthetic for pitch & roll. Vanes in exhaust nozzle for yaw. Engine rpm for altitude.
Undercarriage	Single bumper with forward outrigger (essentially 3-point ground contact)	Twin longitudinal skid type
Flight Accomplishes	Tethered only First flight Dec. 1973	First free manned flight Apr. 17, 1980. 18 flights in 1980. Speeds up to 45 mph. Duration: up to 5-1/2 minutes

3.2.3.2.1 WASP I (Marine Corps STAMP)  
(1971-1972): Figure 3.2.3.2.1.1 depicts the STAMP vehicle as originally visualized by Williams International and Figures 3.2.3.2.1.2 and 3.2.3.2.1.3 present two views of the WASP I with the safety line attached. Figure 3.2.3.2.1.4 shows it in flight. In addition to a wooden mock-up, one flight vehicle was built under the Marine Corps program.

Comparison of the WASP I with its predecessor, the Bell Jet Belt (Figure 3.2.2.3) reveals several major differences between them. These are:

- The use of a stand-on platform instead of the back-pack arrangement.
- The location of the engine ahead of the personnel.
- Placement of the WASP turbofan engine with its intake facing upward. (For compactness, Bell had the engine facing downward and used twin ducts which turned the engine exhaust 180 degrees.)
- Use of three nozzles; Bell used two.
- Location of the nozzles well below the vehicle c.g. Bell located the nozzles above the c.g.
- Pitch and roll control by differential thrust modulation instead of thrust vectoring via moveable nozzles on the Bell device.

Engine - The WASP I used the Williams WR19-9 BPR 5 turbofan engine which was rated at 700 lb thrust (uninstalled) at S.L. standard conditions. This engine operated at 44,000 rpm (fan system) and had efflux velocities and temperatures of 730 fps and 270°F. The fuel consumption was 5.3 lb fuel/min at maximum operating weight (590 lb). Thrust growth to 1100 lb was projected by Williams.

Control Method - In thrust borne vehicles, pitching and rolling moments can be obtained by changing the distance between the thrust vector and the vehicle c.g. Three methods are available: (1) tilting of the thrust vector, (2) shifting of the c.g. with the thrust vector fixed, and (3) shifting of the thrust vector with respect to the c.g.

For WASP I Williams selected a combination of the methods (1) and (3) for pitch and roll control because they believed that method (2) (kinesthetic control) had not yet been adequately substantiated. In the WASP vehicles, unlike the Bell Jet Belt, the nozzles are located well below the vehicle's c.g. With the thrust vector tilting there would be a tendency for initial vehicle translation



Figure 3.2.3.2.1.1 STAMP Vehicle as Originally Visualized  
by Williams Research (Courtesy Williams  
International Corporation)

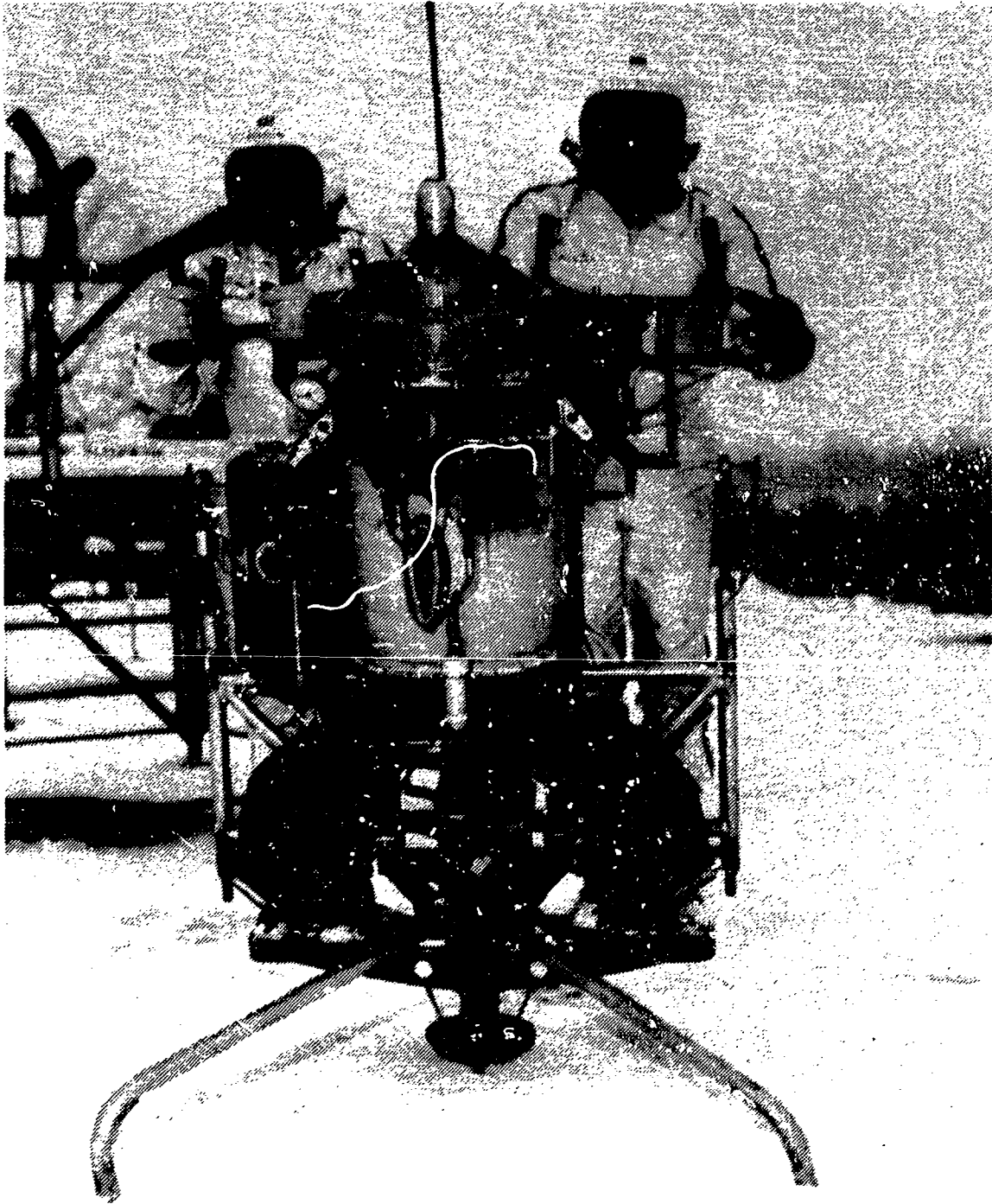

Figure 3.2.3.2.1.2 Williams Research STAMP Vehicle with Tether Line Attached (Courtesy Williams International Corporation)



Figure 3.2.3.2.1.3 Williams Research STAMP Vehicle Side View (Courtesy Williams International Corporation)

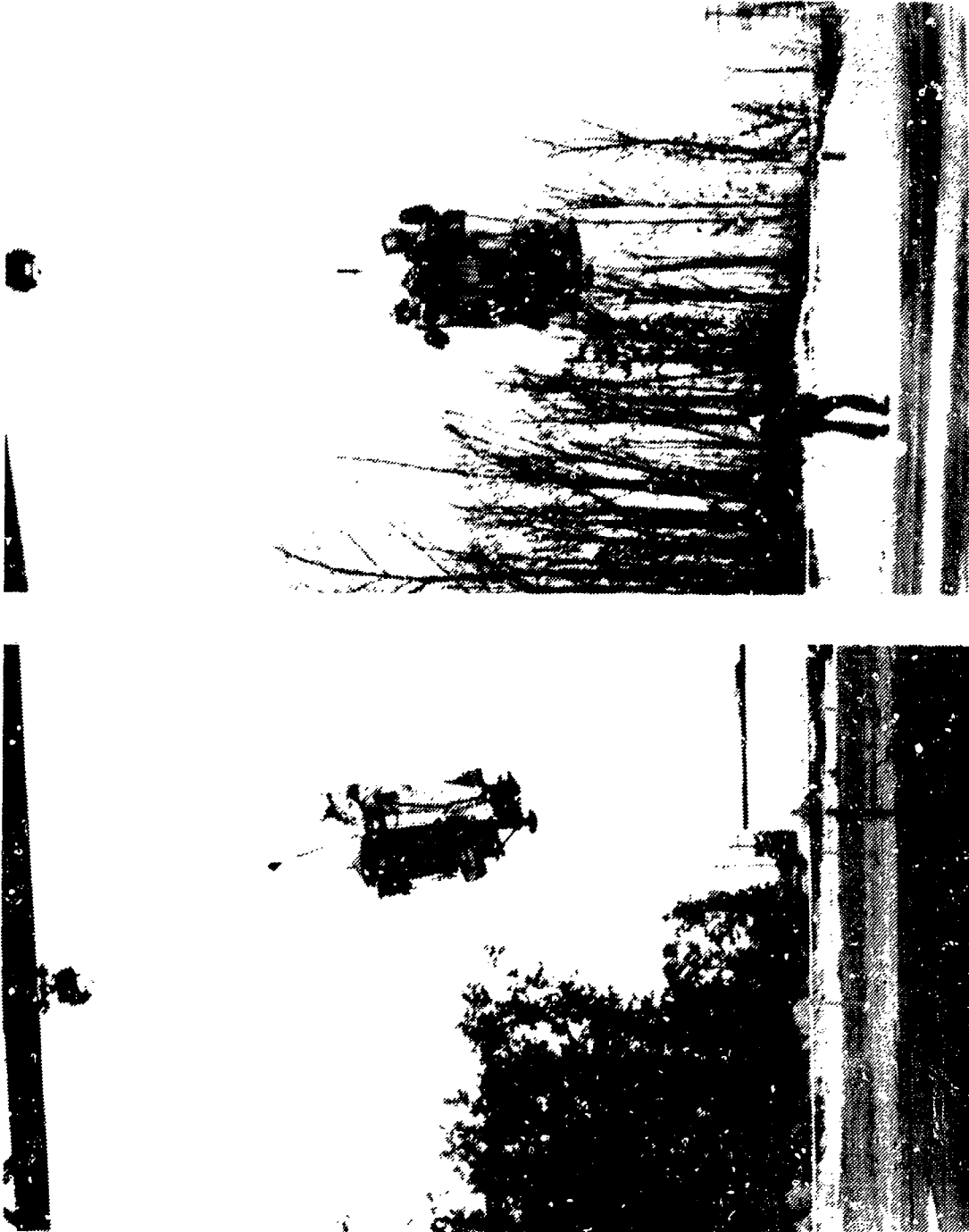

Figure 3.2.3.2.1.4 Williams Research STAMP Vehicle in Flight, Safety Tether Line Unloaded (Courtesy Williams International Corporation)

in the direction opposite to that desired before the vehicle tilts in the direction required, which could result in unnatural flight characteristics.

In the WASP I shifting of the thrust vector was accomplished by dividing the total engine thrust among three nozzles to form a "three-poster" vertical lift system. Thrust distribution was changed by varying the flow among the three nozzles using a combination of a moveable diverter element in the flow at the entrance to the three ducts plus a differential variation in nozzle areas. Thrust vector tilt also was incorporated and made a function of nozzle area variation. The resulting change in vector position produced pitching and rolling moments. Square exit nozzles were used and their areas were changed by moving two of the opposite walls, these being hinged plates. The location of the hinges is indicated in Figure 3.2.3.2.1.3. Opposite movement of the plates varied nozzle area and thrust. When moved in the same direction (in unison), clockwise or counterclockwise, thrust vectors tilted and produced yawing moments. Both area change (for pitch and roll) and thrust vector tilt at each nozzle could be obtained simultaneously. Altitude and rate of climb were controlled by changing engine thrust using the throttle control.

The pilot's controls can be seen in Figure 3.2.3.2.1.5 (WASP I rear view) and Figure 3.2.3.2.1.6 (side view) where the key control system items are:

1. A rectangularly-shaped, tubular frame pivoted at the top for lateral tilting.
2. Padded arms extending rearward from the upper part of the rectangular frame and arranged to pass under the pilot's armpits. This arrangement permitted the pilot to roll the tubular frame for roll control of the vehicle.
3. Two twistable, rotatable handgrips mounted at the end of each of two forwardly extending arms attached to the lower part of the rectangular frame.
4. Pivots mounted at the lower part of the tubular frame permitting up-down motion of the forward extending arms and handgrips for longitudinal control of the vehicle.
5. A Bowden cable connecting the left handgrip with the mechanism for collectively rotating the hinged plates in the duct exits to produce yaw control.
6. A cable connecting the right handgrip with the engine fuel control to vary rpm and thrust.

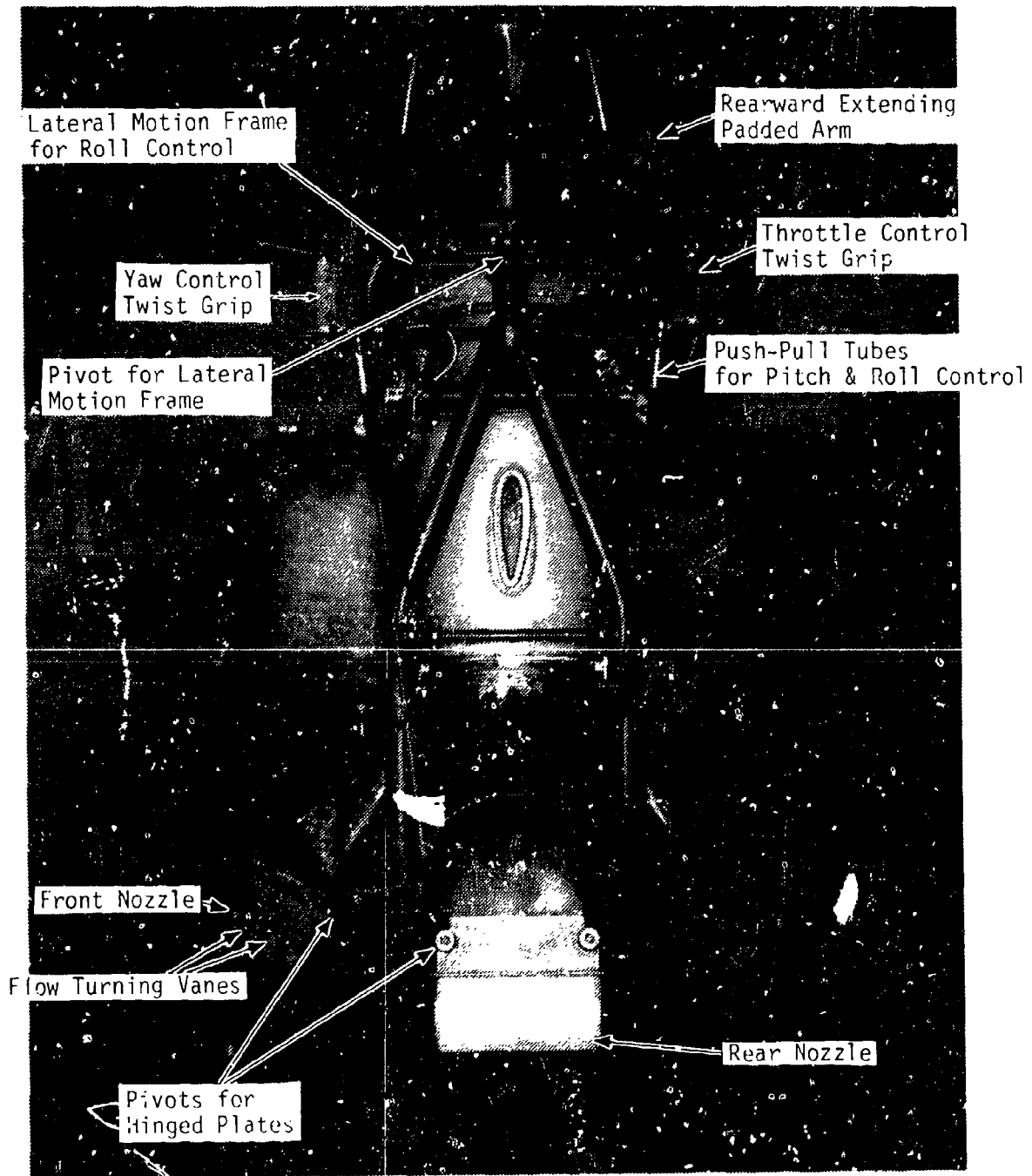

Figure 3.2.3.2.1.5 Williams Research STAMP Vehicle, Rear View - Identification of Key Elements in Control System (Courtesy Williams International Corporation)

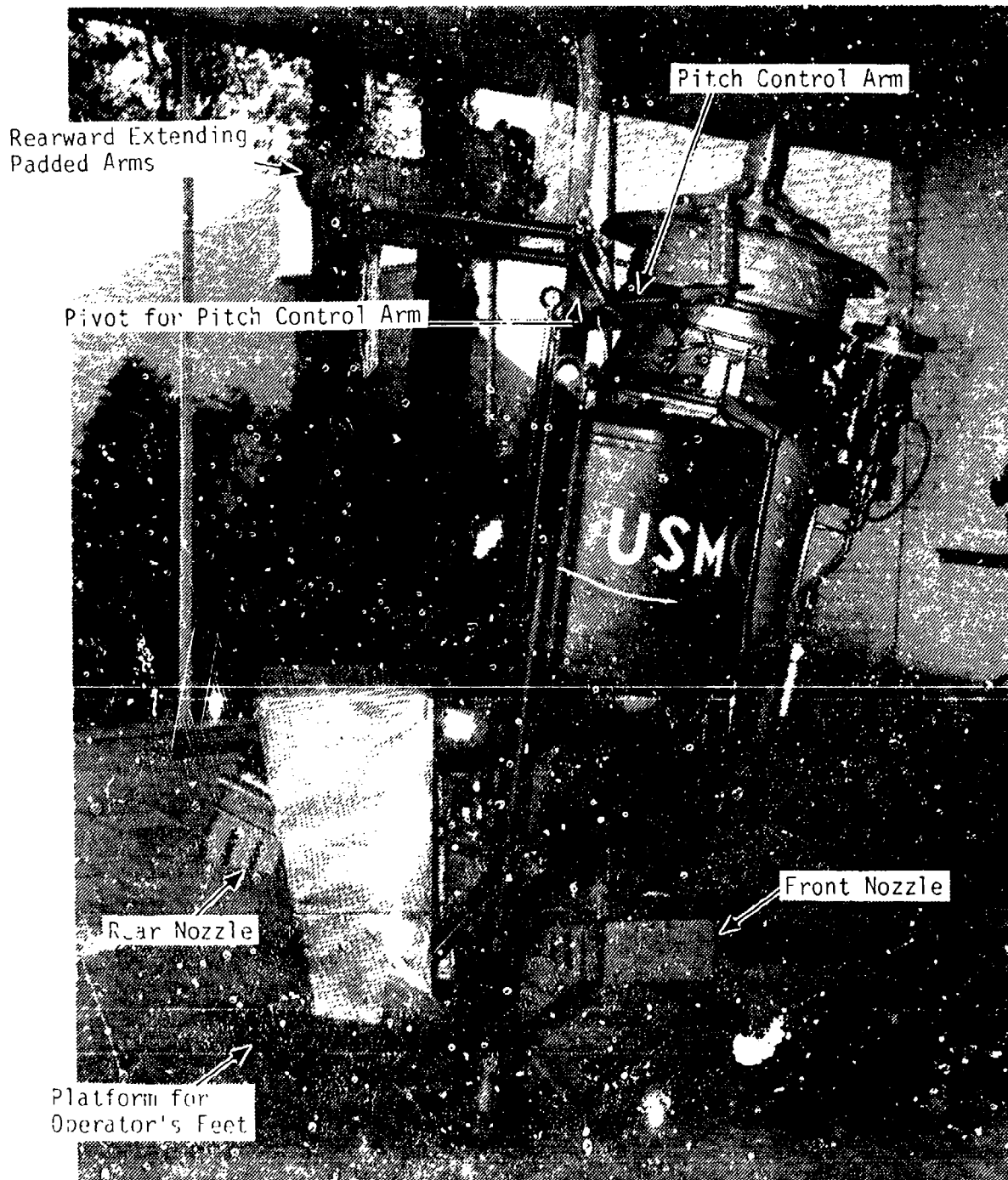

Figure 3.2.3.2.1.1 William Research STAMP Vehicle, Side View - Identification of Key Elements in Control System (Courtesy William International Corporation)

7. Push-pull tubes connecting the rearward extension of the handgrip arms with the mechanism used to move the gas flow diverter and hinged plates in the duct exhaust. Simultaneous up-down motion of the tubes produced longitudinal control and differential motion provided roll control.

The three-nozzle/duct system was arranged with two nozzles spaced laterally apart and positioned ahead of the c.g. The third nozzle was located behind the operator and passenger. To reduce duct length the three ducts terminated in nozzles which were canted outboard, turning vanes being used to provide the final direction of the exhaust flow to vertical. The outline of these vanes is visible in Figures 3.2.3.2.1.5 and 3.2.3.2.1.6. The hinged plates were located above these vanes.

When operated as a single-place vehicle, without a balancing load replacing the passenger, the operator moved to the center of the platform, with his feet straddling the rear duct. His hand controls also were moved to the central position.

Other Features - The under carriage consisted of a single bumper pad located below the platform and aft of the c.g. plus a tubular, triangular frame projecting ahead of the vehicle. Two fuel tanks, were to be used, one at each side of the engine. Figure 3.2.3.2.1.2 shows the vehicle ready for two-man flight with the left tank removed.

In accordance with the contract, the STAMP vehicle was required only to demonstrate controlled, six-degree-of-freedom hovering flight with two individuals aboard, using a safety tether. This was done on January 8, 1974 (Figure 3.2.3.2.1.4) at the Williams International facility. Because of the WR19-7 installed thrust available was only 620 lbs, the two-man flight demonstration necessitated removal of several components from the vehicle (forward landing gear and one fuel tank), reduction of the fuel to a minimum, and operating the engine at maximum safe temperature. A number of brief flights were made and proved that the vehicle could hover, out of ground-effect and be controlled satisfactorily. Earlier, one-man tethered flights had been made successfully.

3.2.3.2.2 WASP II (Army ILD Figure 3.2.3.2.2.1): Williams International's designation is Model No. WR-35. This ILD program was started in June 1978 and completed in March 1983 for which Williams was paid a total of \$2.54 million. The purposes of the program was to:

1. Demonstrate free flight of a one-man, kinesthetically controlled aerial platform.
2. Determine vehicle capabilities.
3. Explore user interest and requirements.

The following table summarizes the principal performance design objectives (requirements), compares them with analytically determined values, performance actually achieved, and that projected for a growth version of the WASP II.

TABLE 3.2.3.2.2.1  
WASP II PRINCIPAL PERFORMANCE CHARACTERISTICS

	Requirement	Analytically Projected	Achieved	Projected Advanced Development
Endurance (min)	30	19.6	5.3	30
Max Speed (mph)	60	60	47	60
Density Altitude (ft)	4000	4000	1000	4000
Useful load less fuel (lbs)	270	185	185	270
	{ Pilot 185 Payld 85			

Under the terms of the initial \$1,582,000 contract signed September 25, 1978, Williams Research built two WASP II vehicles and successfully completed the demonstration phase before September 1, 1980. The first free flight was made on April 17, 1980. Subsequently, seventeen additional free (untethered) flights were successfully performed, speeds of 40 to 45 mph were reached at heights up to 60 feet. Flight durations of over 5 minutes were obtained and operation at a density altitude of 1000 feet was performed. Although two WASP II vehicles were built only one was needed in the tests.

Funds for the next phase of the program were supplied to Williams in September 1981 under a new contract. Work under this contract started in October 1981. The last concept feasibility evaluation flight was made in June 1982 but flight demcnstrations continued at Ft. Lewis, Washington until April 1983. The contract was officially completed in March 1983. Three tasks were involved. Task I was to prepare the vehicles for testing.



Figure 3.2.3.2.2.1 Williams International WASP II  
in Flight (Courtesy of Williams International)

This preparation covered subsystem design (instrumentation), airframe and engine refurbishment, development of the operational envelope, and subsystem and component development efforts. Task II covered the effort required to obtain a limited airworthiness release for the WASP II. This was required by the Army before designated users (Army "G.I.s") would be permitted to fly the vehicles. Task III, Concept Evaluation Testing, was aimed at determining the military potential of this kinesthetically-controlled Individual Lift Device in an operational environment. The results were to be used to help decide if further development of the WASP II should be undertaken.

Under Task I, Williams refurbished the two WASP IIs. Because the WR19-7 engine was not yet man-rated it was considered essential to install a system to warn the operator when any vital engine condition exceeded a pre-set limit. This was done by installing sensors that sent a signal to the operator. Sensors monitored engine high pressure spool speed ( $N_2$ ), exhaust gas temperature, bearing temperature, oil supply, and oil pressure. Exceeding the pre-set limit in any of these resulted in a beeping sound in the operator's head set. In keeping with the objective of vehicle simplicity no gages were installed in the vehicle for operator's use. Vehicle speed was obtained using a hand-held digital doppler traffic radar "speedgun" operated by an observer on the ground. The vehicle's and operator's flight behavior were covered by a video camera.

Williams added a ballistically deployed "Yankee" emergency parachute system for pilot recovery. Because this did not provide single-hand egress capability from the vehicle after a crash with pilot aboard, the Army considered it a hazardous system and had it removed. (A single-hand release was subsequently developed but not installed for the Army tests.) Restriction of WASP II flight to a 15 ft. height was imposed by the Army during operation by Army personnel. Also removed was the exhaust deflector system (see Figure 3.2.3.2.2.3) because of the hazardous design and location of its control handle.

The testing for limited airworthiness release (Task II) was conducted at the Williams facility, Walled Lake, Michigan by the U.S. Army Aviation Engineering Flight Activity (USAAEFA, Edwards AFB, California). Testing took place during cold weather, October 1981 through March 1982. The purpose of the testing was to evaluate the performance, handling qualities and safety of the WASP II and the scope of training required for Army personnel to fly the vehicles during the Concept Evaluation Program. After learning to fly the WASP II at the Williams facility, with Army Major D. L. Underwood as the pilot, the USAAEFA personnel completed a Preliminary Airworthiness

Evaluation (PAE) report (Reference 3.2.12). A total of 59 tests (3 in the gimbal rig, 48 attached to a safety line and 8 in completely free flight) had been completed. The gimbal rig is a ground based device that permits tilting of the WASP II without translation, allowing the pilot to experience the use of kinesthetic control. In the free flights only moderate maneuvering was performed. Total engine operating hours was 12.7 of which 6.1 were productive testing.

Based on the preliminary airworthiness evaluation, the significant conclusions regarding the WASP II as a flying vehicle were:

#### Overall

1. The WASP II could be safely flown throughout the prescribed, limited flight envelope (15 ft. height, 15 Kt. speed) with minimal control margins available for normal flight maneuvers. (It should be noted that speeds of over 40 mph were reached by a Williams operator during the development phase and, later, during the Concept Evaluation Phase.)

#### Handling Qualities

2. The handling qualities characteristics of the vehicle tested differed significantly from those predicted by Williams.

3. The vehicle motions about all axes are aperiodic, that is, all motions were divergent until stopped by the pilot's application of kinesthetic and yaw control.

4. Extensive pilot compensation (body movements and manipulation of throttle and yaw controls) was required for control.

5. The vehicle was extremely sensitive to pilot position (longitudinal and lateral kinesthetic control). Large pitch and coupled roll attitude changes occurred with little lag and required recovery within 1 to 2 seconds following pilot's body displacement.

6. The vehicle was directionally unstable requiring large, frequent displacement of the directional control. Yawing motion produced roll and increased operator workload. The directional instability was attributed to the asymmetric aerodynamic forces on the twin engine air inlet lips located at the sides of the vehicle.

7. Gust response was poor for gusts exceeding 5 knots. Vehicle motions in winds exceeding 10 knots, or exceeding 10 knots in translatory flight, required corrective control applications about all axes continually.

8. Cross-coupling was excessive between pitch and roll and also between yaw and roll, substantially increasing pilot workload and detracting from maneuverability. Pitch-roll coupling was attributed to both gyroscopic effects from the engine and pilot's inadvertent body motion. The roll produced by yawing motion appears to derive from inadvertent motion of the pilot's body when he operated the directional control twist grip. Roll did not produce yaw.

Installation of arm rests, as recommended by the USAAEFA, changed the flying qualities from requiring extensive pilot compensation to requiring only moderate compensation.

9. The anthropometric design of the vehicle was inadequate. This resulted in increased ergonomic stress on the pilot and detracted from his ability to control the vehicle.

#### Performance

10. Lifting capability and useful load varied with altitude and ambient temperature resulting in seriously reduced flight endurance, even under moderate temperature and altitude conditions. The 30 minute flight endurance requirement could not be met even at the lowest temperatures experienced during the tests.

11. A minimum thrust/weight of 1.1 is required for take-off. The thrust of the WASP II engine, when operating near the ground, is degraded by "suckdown" (negative ground effect) and exhaust gas reingestion (recirculation). The degradation during the USAAEFA testing was higher than expected based on previous tests by Williams.

12. The speed capability of the WASP II was not established because of operating limits placed on the vehicle for safety reasons. Speeds exceeding 40 mph have been reached however.

#### Noise and Vibration

13. Noise was excessive during take-off, hover near the ground and landing, exceeding the maximum 108dBA design limit of MIL-STD-1474B by at least 20dBA near the pilot's head.

14. High frequency vibration of the airframe was excessive when operating close to the ground, but tolerable for short time periods.

15. Low frequency vibrations were excessive with landing gear skids between 3 and 10 ft. above ground, resulting in reduced pilot performance. These vibrations (low frequency beat oscillation) are probably due to induced pressure effects and forces on the vehicle of the jet efflux impinging on the ground.

## Airframe

16. The skid base dimensions were too small restricting depolyability of the vehicle to improved level surfaces. (Increase in base dimensions could be rezdily done but would decrease the compactness of the vehicle.)

17. Foreign object damage protection was inadequate. An inlet screen covered each inlet. The 1/2 inch square mesh of the screen permitted foreign objects to reach and damage the by-pass fan during hover with WASP II skids 10 ft. above the ground. (Damage to the engine due to foreign material ingestion may be a difficult problem to solve, even with a finer mesh screen.)

Because it could be flown and adequately controlled the WASP II was cleared for Task III, Concept Evaluation testing under the prescribed altitude and speed restrictions. A few G.I.s were trained by Williams to fly the WASP II vehicles and some flights were made at Ft. Benning, Georgia. In May 1983 Concept Evaluation testing was undertaken by the 9th Infantry Division at Ft. Lewis, Yakima, Washington. This infantry division is the "prototype" Light Infantry Division charged with the task of evaluating relevant, new, air transportable infantry equipment for the Army. In the evaluation the WASP II was used as a reconnaissance vehicle in an exercise called "LASER LIGHT". The WASP II operator, a Williams pilot, working with the 2nd light attack battalion, used the vehicle to obtain information and report on the "enemy Red Forces" activity. No restrictions were imposed on the Williams pilot by the Army.

Three missions were performed ranging from 4 to 5 minutes duration, these being limited by the WASP II's fuel load. Additional operations of the WASP II during the "LASER LIGHT" exercise were abandoned because of the breakdown of the ground transport equipment used. During the exercise the vehicle was flown through clear areas in wooded terrain, performing the required maneuvers. Despite the imposed restrictions, speeds as high as 47 mph were reached.

No report was available on the 9th Infantry Division Evaluation, but it is known that the Army personnel concluded that:

1. The WASP II performed adequately mechanically.
2. The flight durations available were too short for combat operations.
3. Noise did not rule out use of the vehicle.

4. Regarding the dust cloud created by the WASP II when operating over loose soil, the cloud's visibility was not considered detrimental, but its thermal characteristics (heated air and dust particles) could be a problem in attracting enemy attention.

Indications from other sources are that the WASP II was judged to be unsatisfactory because, in addition to its limited flight duration, 1) its poor handling qualities and resulting pilot workload seriously interfered with the reconnaissance activity and 2) its limited useful load precluded the installation of needed defensive equipment.

After completion of the Task II work Williams International proposed to the Army, the manufacture and delivery of 20 improved WASP vehicles at a cost of \$35 to 40 million. This was to cover redesign, product qualification, tooling, manufacture, etc. Williams estimated the WASP unit delivered price to be \$250,000 in production. The Army Deputy Chief of Staff for Research and Development and Acquisition (DCSRDA) decided against further development of the WASP vehicle because it was too noisy, flight time was too short and the vehicle was too expensive.

The following information was obtained from References 3.2.11 and 3.2.12.

#### General Description

Figures 3.2.3.2.2.1 and 3.2.3.2.2.2 are photographs of the WASP II in flight and on the ground. Figure 3.2.3.2.2.3 is a 3-view drawing of the vehicle with the major elements identified and Figure 3.2.3.2.2.4 is an exploded view showing the main components.

The engine is mounted nearly upright but with a 15 degree forward inclination to permit it to be located just ahead of the standing operator for longitudinal balance and to provide him with clearance to move. The exhaust duct is curved and attaches to a single, vertical nozzle with its thrust axis aligned with the c.g. A tubular truss supports the engine at the rear of its casing. Yaw-producing vanes are mounted in the nozzle exits. Below the vanes is an "L"-shaped, moveable deflector plate to keep the engine exhaust from impinging on the ground prior to take-off and after landing.

Unlike the WASP I, air is brought into the engine through two screened inlets, one at each side of the vehicle, with the objective of obtaining directional stability in forward flight without the use of a vertical tail. It was theorized that yaw would produce differential momentum drags at the inlets and, consequently, a



Figure 3.2.3.2.2.2 Williams International WASP II  
on Ground Handling Dolly (Courtesy Williams  
International!)

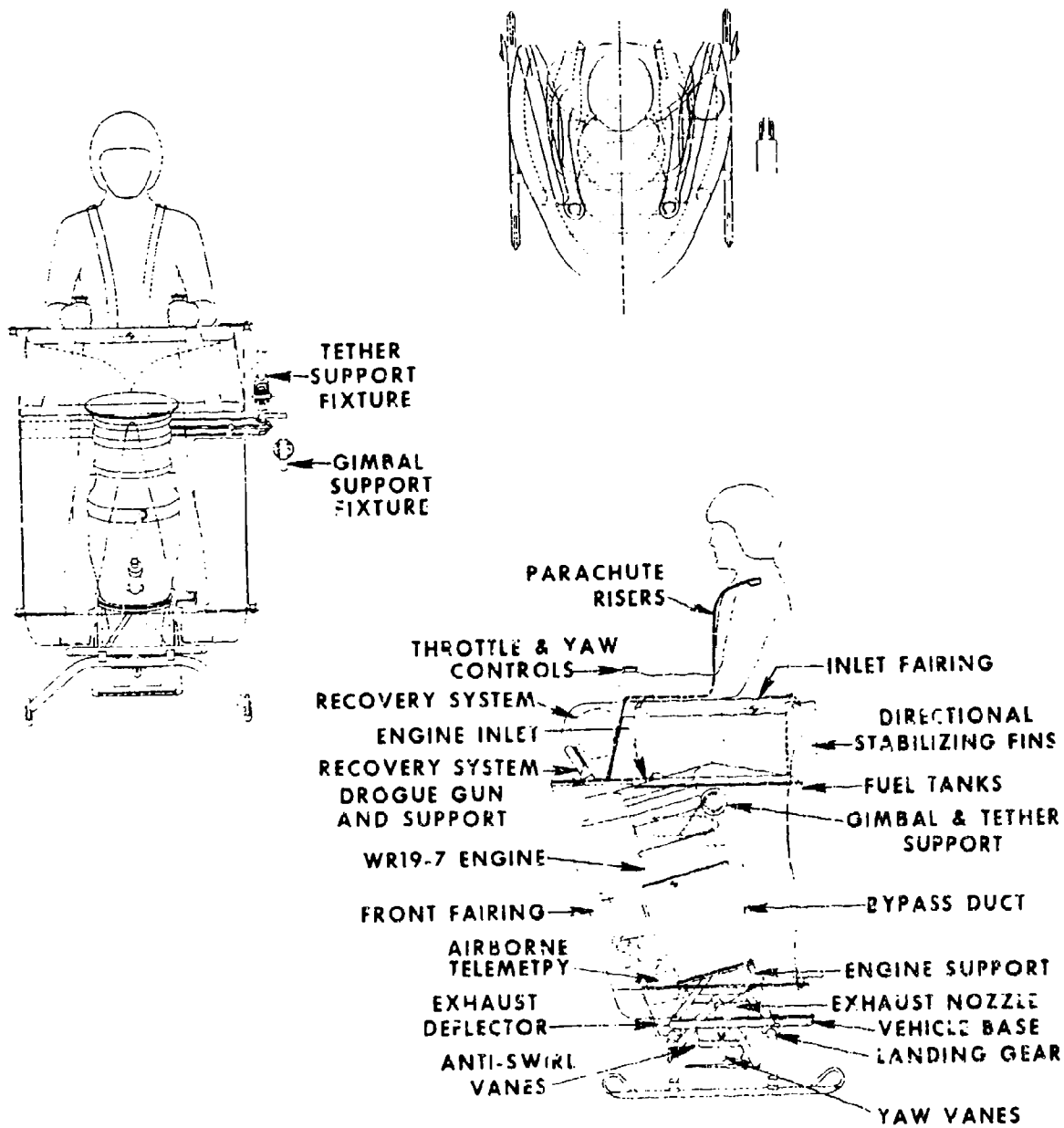

Figure 3.2.3.2.2.3 Three-View Drawing Williams WASP II (Courtesy Williams International)

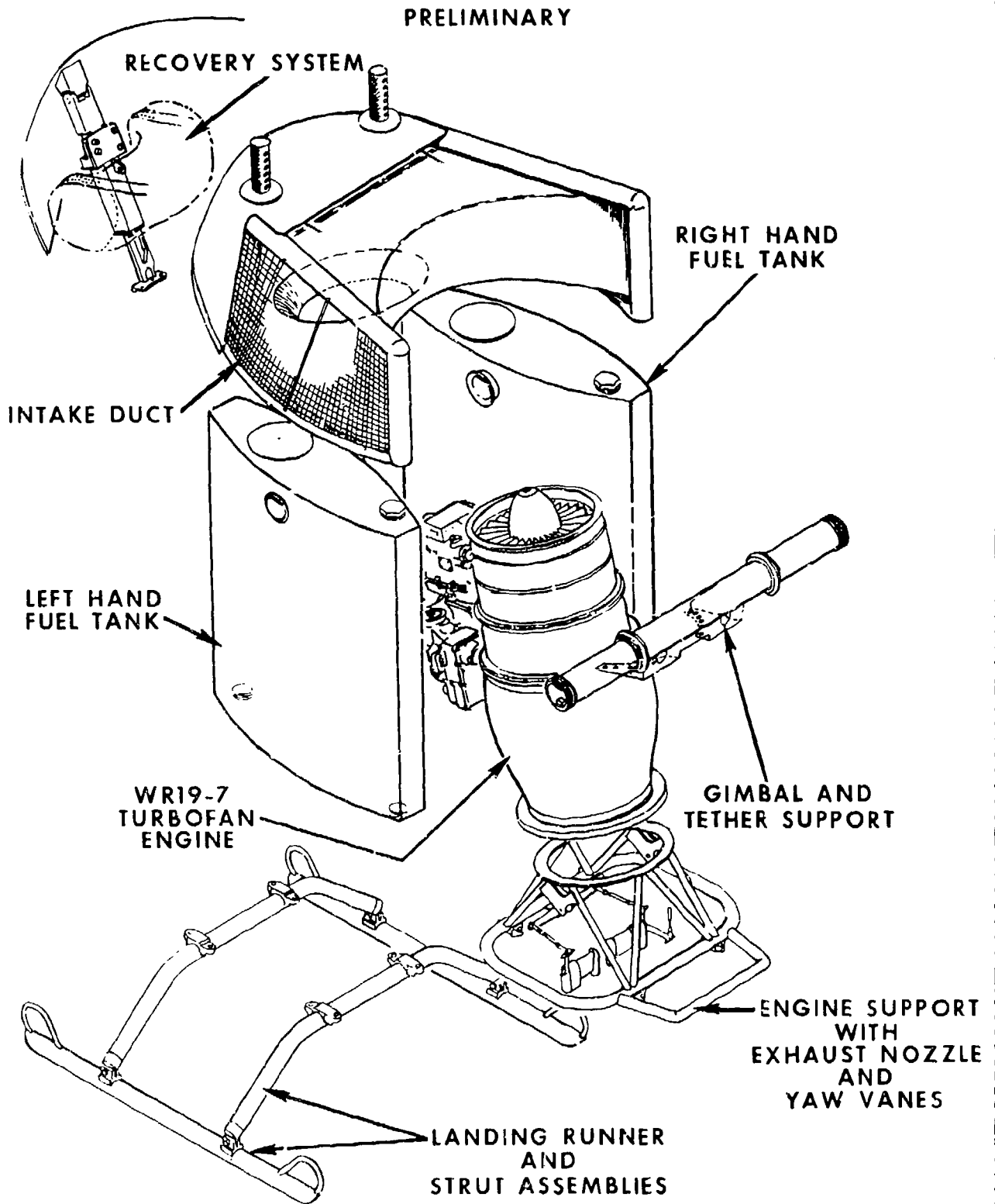

Figure 3.2.3.2.2.4 Main Components of Williams International WASP II (Courtesy Williams International)

restoring yawing moment. Flight tests showed that this did not work and twin, narrow chord vertical fins were added directly behind the outer edges of the airframe. The inlets have been placed close to the c.g. vertically to minimize pitching moment due to inlet air momentum drag

The vehicle frame is constructed primarily of aluminum alloy and provides a mounting base for the other elements of the WASP II system. These consist of the platform for the operator, engine mount, landing gear, engine exhaust nozzle and yaw vanes, exhaust deflector and actuator, fairings, directional stabilizing fins, two fuel tanks, yaw and throttle controls, and the gimbal and tether support. The fuel tanks are mounted at the sides of the vehicle using the gimbal/tether support structure. Within the upper forward fairing a compartment is provided for the operator's ballistically-deployed emergency parachute. The frame and its fairings are open at the rear so that the operator can step on board and off readily.

The vehicle frame is designed to use the engine by-pass duct and interstage housing as the primary structural members between the engine mount, vehicle base and gimbal/tether support.

#### Weight Summary

The following table summarizes the WASP II weights:

TABLE 3.2.3.2.2.2

#### WASP II WEIGHT BREAKDOWN

Airframe	116 lbs.
Engine	135
Operator	185
Fuel (1/2 capacity)	.75 (about 13 minutes total flight time)
Total	511 lbs
Minimum flight weight	453 lbs (With three minute fuel reserve)

Engine

The WR19-7 engine used in the WASP II is a modified Williams cruise missile engine (F-107). It is a short life, non-man-rated engine. Figure 3.2.3.2.2.5 shows the engine's inner details and airflow. It is a two-spool engine with the spools counterrotating to reduce vibration and gyroscopic reaction effects on the flight vehicle.

The engine has a 1.07 by-pass-ratio and weighs 135 lbs. Uninstalled maximum continuous thrust is 580 lbs., obtained at 61,800 rpm (high pressure spool) under sea level standard day conditions. The corresponding air mass flow is 13.5 lb/sec. Installation losses, about 6%, reduce the available thrust to 545 lbs. Specific fuel consumption is 0.63 to 0.64 lb/lb thrust/hr giving a fuel flow of about 5.7 lb/min. The actual fuel flows and projected flight endurance, obtained during tests by Williams in their gimbal rig, are shown in Table 3.2.3.2.2.3. Exhaust is a mixed flow of by-pass air and turbine exhaust giving a 620°F efflux temperature and 1400 fps velocity. Disc loading, based on nozzle exit area, is 2300 lb/sq. ft. at take off weight (511 lbs.). For safety purposes a Kevlar containment shroud is wrapped around the turbine section.

Table 3.2.3.2.2.3

Williams WASP II Actual Fuel Flow and Endurance Summary<sup>1</sup>

OAT (°C)	Useable Fuel Loading <sup>2</sup> (lb)	Fuel Flow <sup>3</sup> (W <sub>F</sub> lb/min)	Endurance (min)
-10	154	7.2	18.6
0	121	6.4	15.8
10	81	5.9	10.3
20	41	5.5	3.8
25	19	5.5	0.0

NOTES:

<sup>1</sup>Min T/W = 1.1

Basic weight = 256 lb

Operator weight = 180 lb (equivalent to 50th percentile aviator with flight equipment and clothing) Barometer = 29.00 inch Hg

<sup>2</sup>Including 3 min fuel reserve = 20 lb

<sup>3</sup>Computed for maximum thrust at N<sub>2</sub> = 61,800 rpm at ambient conditions.

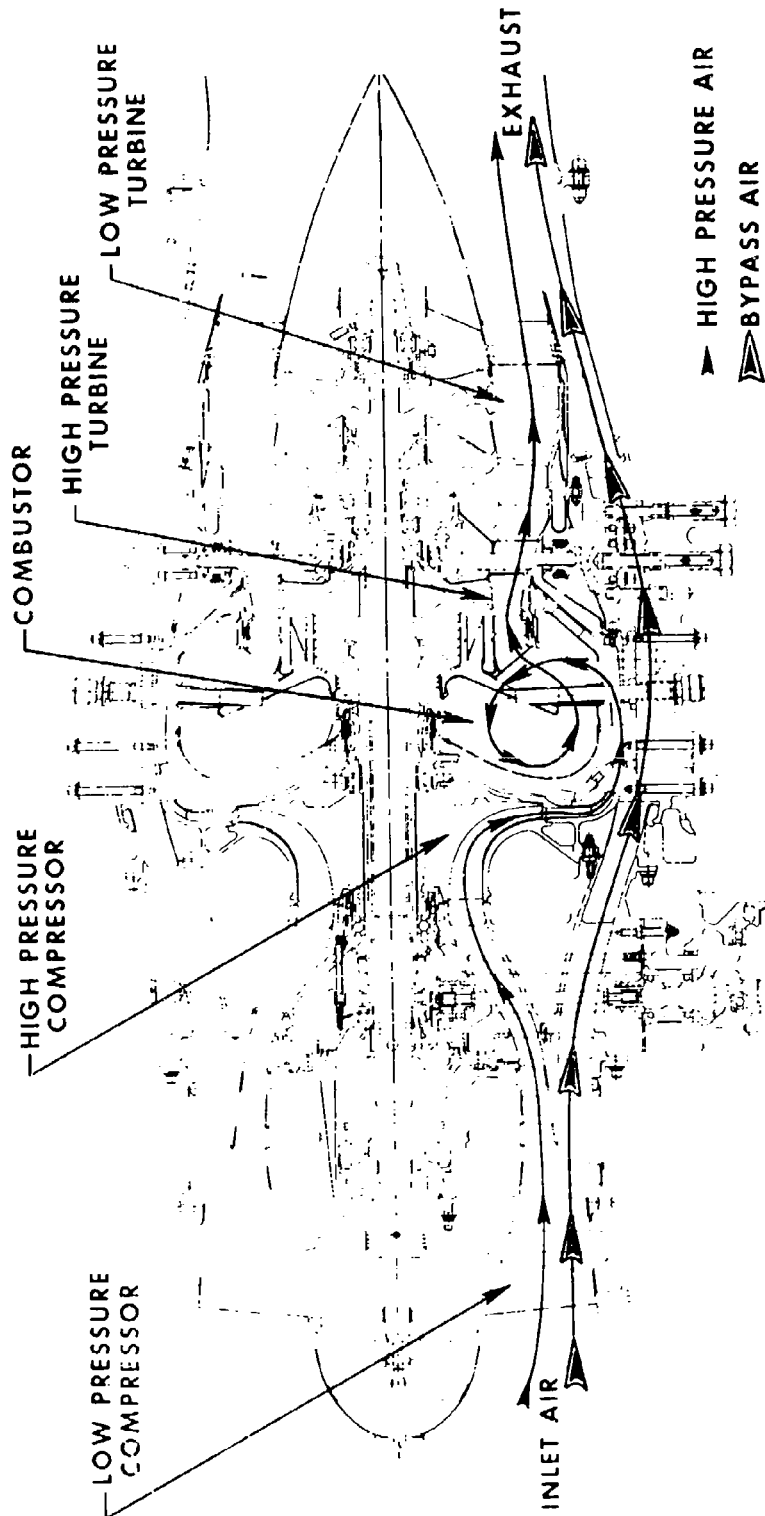

Figure 3.2.3.2.2.5 Williams WR19-7 Internal Engine Details and Air Flows

## Flight Control

As in the WASP I no stability augmentation system was used in the WASP II. The WASP II is based upon the use of kinesthetic control where the vehicle c.g. (pilot's body) is moved with respect to the thrust vector for pitch and roll control (see earlier discussion of WASP I control). Yawing motion is obtained from the differential movement of two laterally-disposed vanes located in the engine efflux. Altitude and climb are controlled by varying engine rpm and, hence, thrust. Twist type vertical handles are used for yaw (left hand) and thrust control (right hand). The yaw handle directly controls yaw vane angle and the thrust control handle inputs command into the engine's control unit. An important consideration in kinesthetic control is the pitch angle of the vehicle required with forward speed. Figure 3.2.3.2.2.6, shows the theoretical variation in pitch angle with speed. At 60 mph (required capability), a pitch angle approaching 20 degrees is estimated; at 90 mph this increases to 38 degrees.

## Other Features

The twin skid landing gear is mounted to the vehicle base without any shock absorbing devices and relies on the struts to absorb loads through structural deflection. The skid length and spacing provide base dimensions giving a turn-over angle of about 69 degrees (63 degrees is the maximum permitted for aircraft). Design landing loads were to be (Reference 3.2.11) 3g vertical and zero g horizontal with full fuel (580 lbs gross weight).

The frame of the vehicle contains provisions for a tether line and a gimballed mounting system located near the c.g. (see Figure 3.2.3.2.2.3.). These were incorporated for training pilots prior to free flight and for obtaining selected test data.

A standard 24 ft. flat circular, ballistically deployed "Yankee" parachute system is used for pilot escape. The parachute is contained in a compartment within the upper front fairing of the vehicle and is attached to the pilot via risers and body harness. Firing of the parachute is by either of two electrical switches mounted on top of the yaw and throttle control handles. Flight at low level, among trees would be done without the parachute since the "Yankee" system is designed for safe ejection at heights over 50 ft above ground level. Release of pilot from the airframe and firing of the parachute required use of both hands or two sequential motions with one hand (considered unacceptable by the Army).

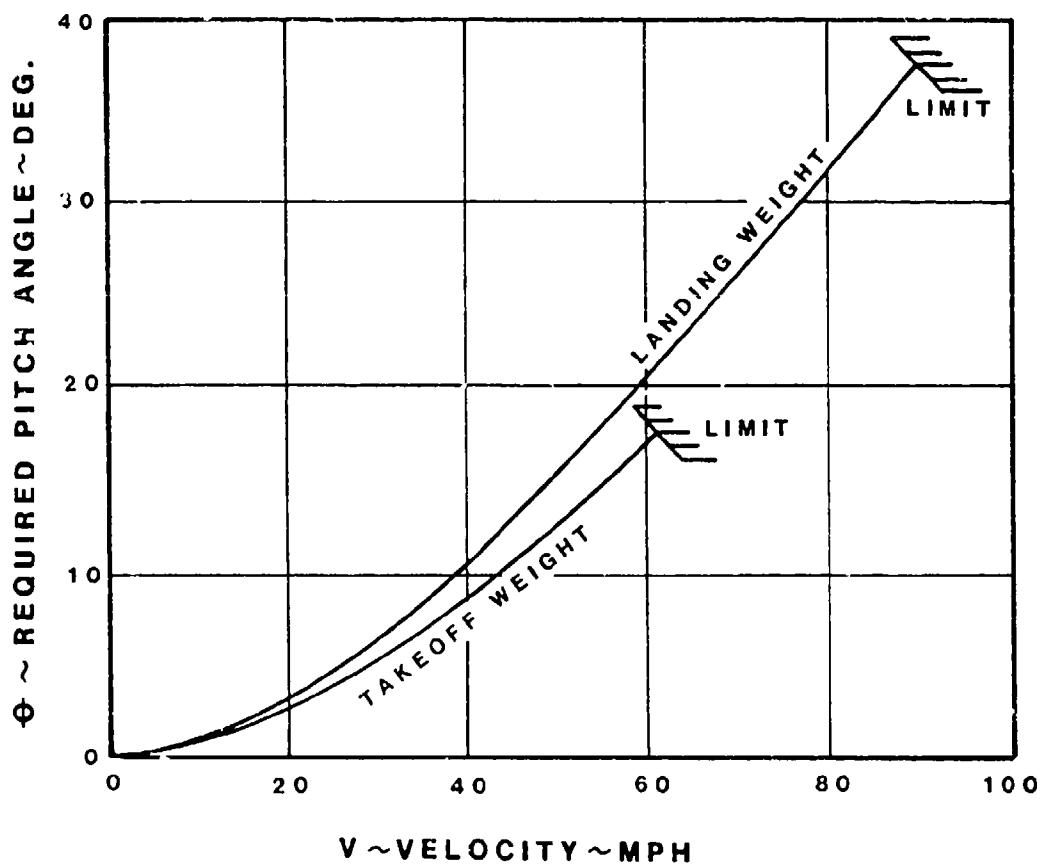

Figure 3.2.3.2.2.6 Williams International WASP II  
Theoretical Pitch Angle with Speed (from Reference  
3.2.11)

The vehicle had no instruments of any kind. On the concept evaluation vehicles, engine starting was done by remotely supplied compressed air.

Concluding Observations on the WASP Vehicles:

1. The WASP II effort shows that a compact individual lift device (ILD) using a turbojet engine for lift and pilot's body movement for control (kinesthetic) can be built and controllably flown. However, the WASP II revealed the problems inherent in such high "disc loading" devices: high noise, strong ground disturbances, high fuel consumption, reduced payload weight-fraction and flight endurance compared with bulkier but lower disc loading powered lift systems.
2. Characteristic of the WASP type ILD is high production cost arising from the use of turbojet engines. Unless low cost turbines can be built, the high cost probably will preclude consideration of such vehicles for military (and civil) uses.
3. The WASP II vehicle, based on the use of kinesthetic control, is appreciably simpler than the WASP I with thrust vector control. However, the WASP II illustrated the problems inherent in such a kinesthetically-controlled platform - - problems of high sensitivity to pilot's body motion, lack of vehicle inherent motion damping, coupling of motions due to gyroscopics and due to pilot's inadvertent body motion. Because of these problems learning to fly the WASP II took more time than expected. The Army visualized a machine which could be flown with a small amount of training and skill (such as needed to operate a motorcycle).
4. It is not certain that kinesthetic control is the best solution for the jet supported individual lift device. In the light of the WASP II experience the use of thrust vector control (TVC) needs to be reexamined, particularly because it lends itself readily to use of stability augmentation systems. It may be that a well-designed TVC system with stability augmentation may lead to a better military vehicle than one that is primarily controlled by kinesthetic means.
5. From the WASP II experience it is apparent that more attention must be paid to vehicle aerodynamics during the design and development stage, particularly as affected by the airflows into and out of the engine. Good aerodynamic design should, at least, minimize the destabilizing effects of gusts and winds on vehicle behavior. Preferably, the vehicle should hold its position and attitude despite winds and gusts.

6. Maneuverability of ILDs is an important consideration because such a vehicle must be able to do terrain following, turning to avoid obstacles or "jinking" to avoid enemy fire. This requires a capability to generate lift in excess of vehicle weight ("g" capability). The greater the excess lift available, the more maneuverable is the vehicle. Winged vehicles, including helicopters, are capable of producing 2g and higher forces in forward flight. In WASP type vehicles only the excess thrust is available for maneuvering and for the WASP II the "g" capability (T/W) ranges from 1.1 at maximum take-off weight to 1.24 at minimum flight weight under standard day, S.L. conditions. At 10 mph, permissible steady state, constant altitude bank angles are 25 and 36 degrees respectively at these T/W's, resulting in turn radii of 15 and 9 ft, respectively. At 60 mph, and accounting for vehicle drag, the respective bank angles are 18 and 30 degrees resulting in turn radii of 744 and 411 ft at maximum takeoff and at minimum flying weights, respectively.

7. The T/W needed for an ILD will depend on the maneuvering capability and forward speed required and on its intended use, for example, combat or non-combat operations. Based on the foregoing turn radii and the fact that higher altitudes and ambient temperatures reduce the thrust available, it is probable that higher thrust-to-weight ratios will be needed than are available in the WASP II. This could result in higher vehicle cost.

8. Because the vehicle's maneuver capability is related to its instantaneous weight (T/W), changing with time due to fuel use, the operator will have to adjust his control inputs during flight. This will probably become automatic with experience.

9. Unlike some vehicles with fixed wings, the WASP does not have an abrupt stall and consequent loss of altitude characteristic. When maneuvers exceed the capability of the thrust to maintain altitude at a given speed, the vehicle will continue to fly as before but on a downwardly inclined flight path. A reduction in speed (by leaning back) will elevate the flight path. High speed flight close to the ground still may be hazardous.

10. A key problem, recognized by Williams International and the Army, is the WASP's jet blast (620°F temperature, 1400 fps velocity). When operating near the ground (as in flight over loose soil and rocky areas) much debris will be dislodged and propelled outward at substantial speed. Close flight over or near individuals may cause problems. There is an unresolved question of combustion when operating over dry vegetation. The exhaust gas temperature could cause ignition but this is countered by the suppression of combustion by the high velocity gas flow.

11. The high noise inherent in the WASP type vehicles may limit its mission capabilities.

12. The dust and thermal signature is a consideration in certain combat operations. The large thermal dust cloud is inherent with direct jet lift vehicles.

13. The requirement for a parachute will be a matter of policy and operating conditions. It is probable that a true "zero-zero" parachute will be required until a large number of flights have demonstrated a very high degree of propulsion system reliability, as in the case of the Bell Rocket Belt where 3000 flights were completed without a malfunction.

3.2.3.3 Garrett-AiResearch Manufacturing Company  
 STAMP (1972-1974)

AiResearch's concept for a STAMP vehicle was substantially different from that of Williams Research. The AiResearch approach was to put the pilot, passenger and propulsion components in a body somewhat similar to that of an airplane fuselage and to use the flow from a fan operating inside the body to provide the combined lift-propulsion force through nozzles located at the body's sides. This was the basis for their May 3, 1972 unsolicited proposal to the Navy for a STAMP feasibility demonstrator. The concept was selected by the Naval Weapons Center as one of the preferred solutions to the STAMP, resulting in the \$662,092 contract (N00123-73-C-1073) awarded on December 29, 1972. Later, an additional \$127,700 was added to the contract bringing the total to \$789,792. A ten month effort to design, build and demonstrate the vehicle in tethered flight was undertaken.

Figure 3.2.3.3.1 is an illustration of the vehicle originally proposed by AiResearch. The actual demonstrator that was built (Figures 3.2.3.3.2 through 3.2.3.3.5) is bulkier and less integrated. Because of the modest funding it was decided to use some components of an existing aircraft and, also, to minimize the design optimization effort. An OH-6A helicopter forward fuselage, seats and landing gear were supplied by the Army and incorporated into the demonstrator airframe. The rear airframe was built to accommodate the engine, fan and drive system, inlet, ducting, nozzles and tether attachment. Although the design optimization effort was minimized, AiResearch did attempt to build a lightweight airframe and air handling system, a satisfactory fan and drive system and a reasonably flow efficient fan, ducting and nozzle system. A limited amount of developmental testing was done on critical components such as the fan, stators and ducting to prove their operational capability.

Prior to the tether tests at the end of the program, static tests were undertaken in a special rig to check the functioning of the propulsion system, vertical lift capability and the controllability. For the latter a limited four degrees of freedom motion (pitch, roll, yaw and vertical) was allowed. The AiResearch program culminated in flights, in ground effect, with the tether safety line unloaded during hover. Fourteen minutes of flight with two men aboard and with skid gear 6 to 8 inches above the ground were accomplished (Figure 3.2.3.3.6) between December 20 and 22, 1973 at El Toro Marine Corps Air Station, California. This satisfied the requirements of the contract.

After completion of the initial flight demonstrations, the AiResearch effort and the other STAMP efforts were not pursued further by the Navy/Marine Corps. Additional development of a STAMP vehicle was dropped primarily



Figure 3.2.3.3.1 STAMP Vehicle as Visualized by AiResearch  
(Courtesy AiResearch Manufacturing Co.)

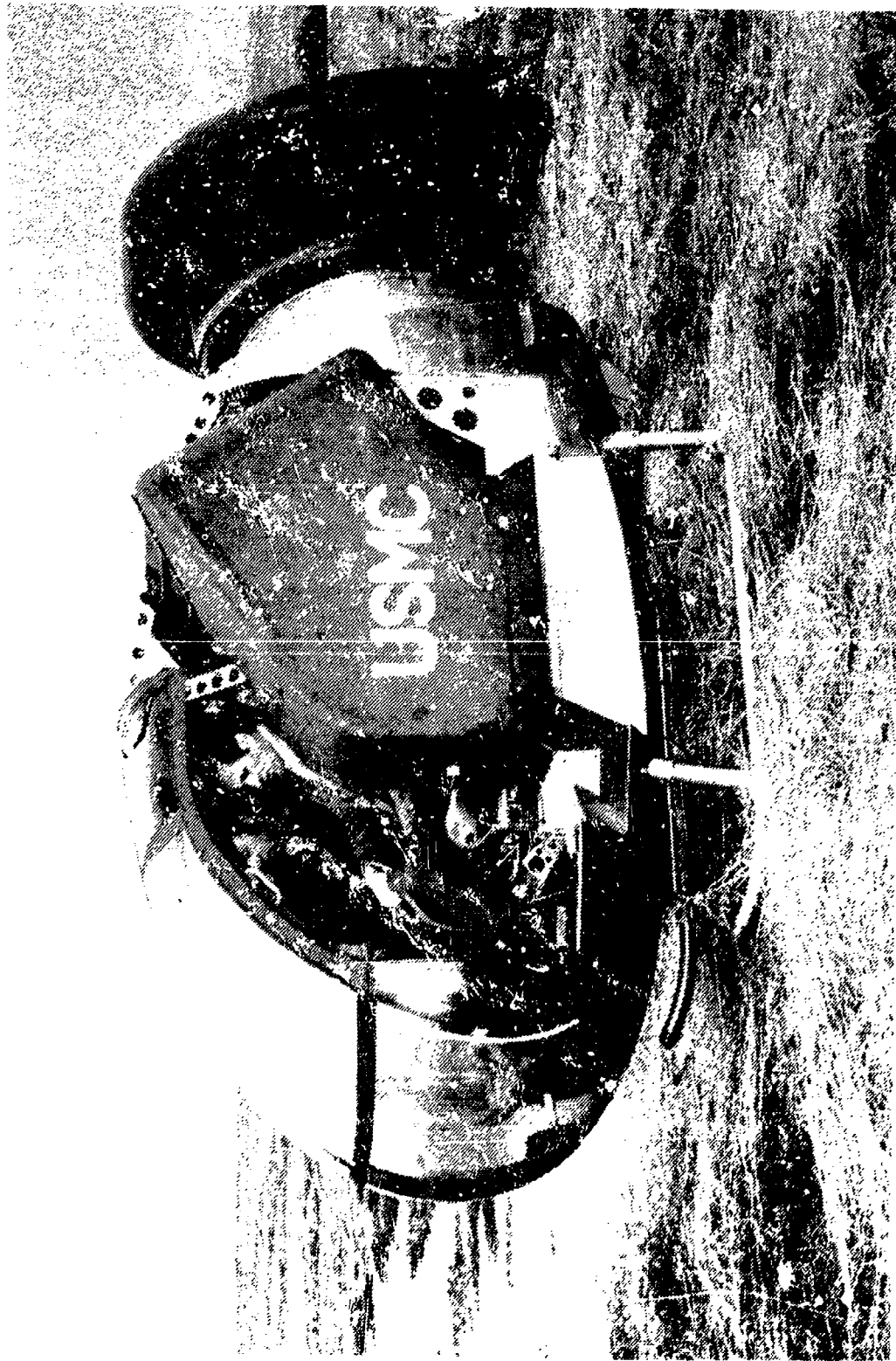

Figure 3.2.3.3.2 AiResearch STAMP Feasibility Demonstrator Vehicle, Side View  
(Courtesy AiResearch Manufacturing Co.)

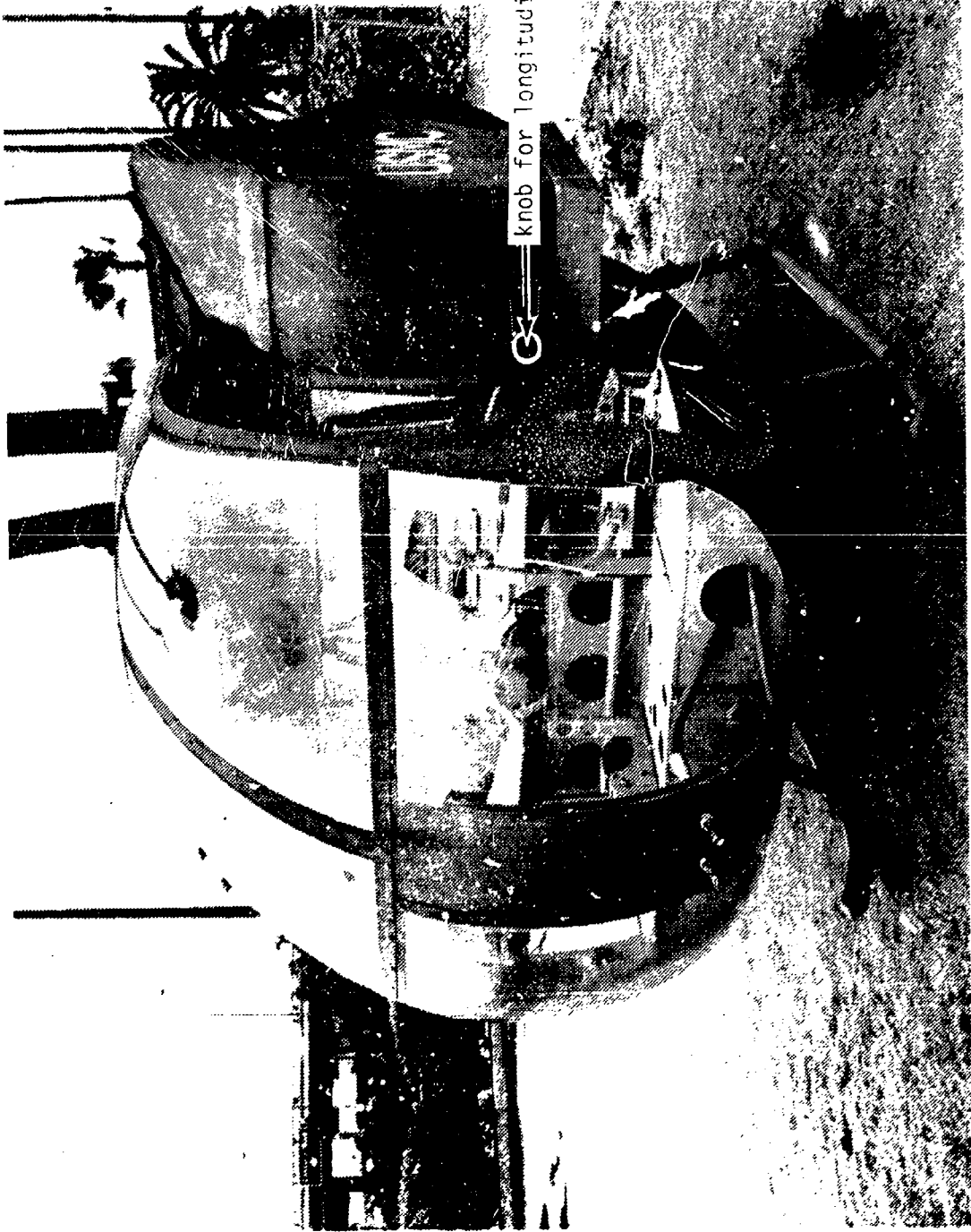

Figure 3.2.3.3.3 AiResearch STAMP Feasibility Demonstrator Vehicle, Front View  
(Courtesy AiResearch Manufacturing Co.)

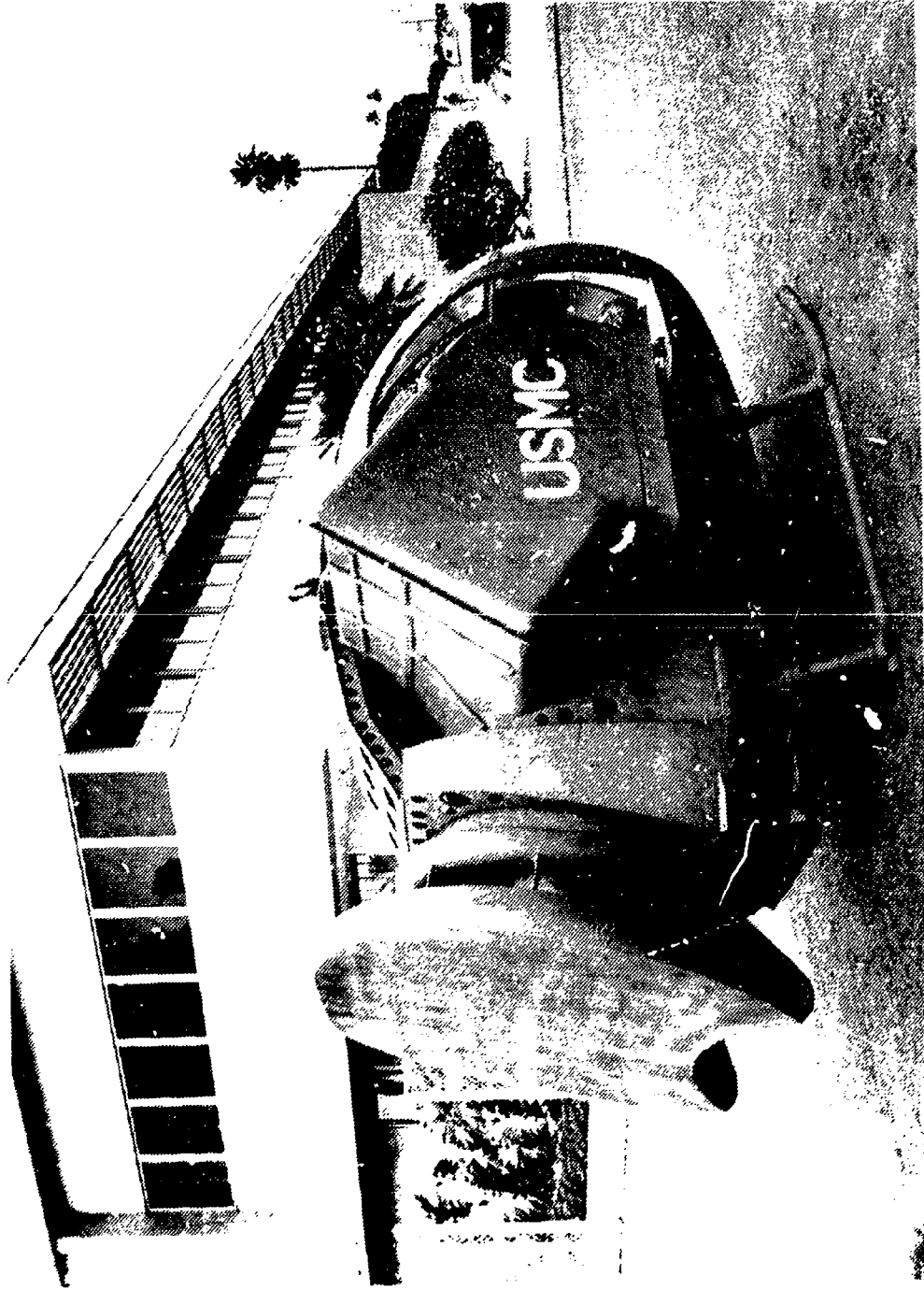

Figure 3.2.3.3.4 AiResearch Feasibility Demonstrator: STAMP Vehicle, Rear View  
(Courtesy AiResearch Manufacturing Co.)

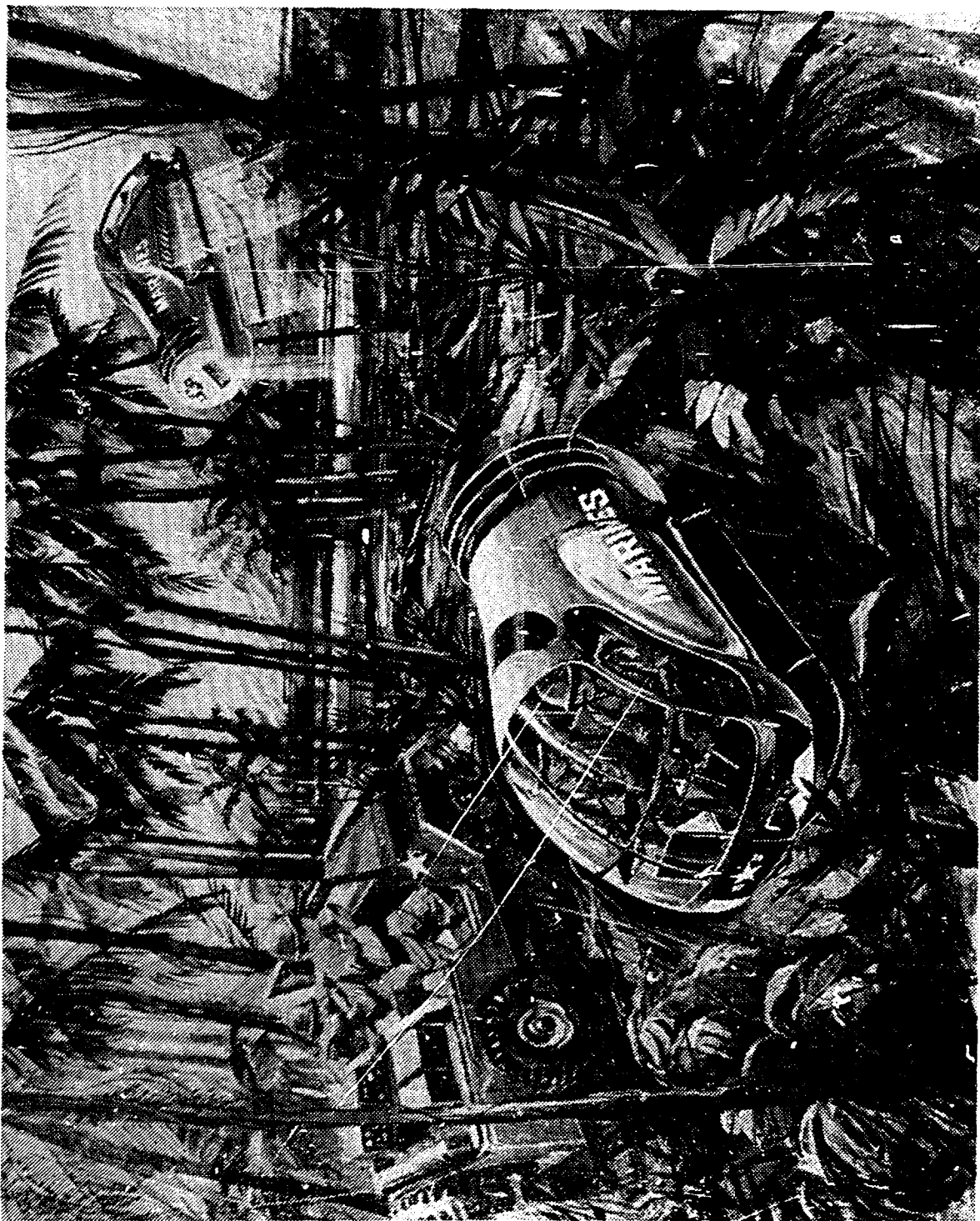

Figure 3.2.3.3.1 STAMP Vehicle as Visualized by AiResearch  
(Courtesy AiResearch Manufacturing Co.)

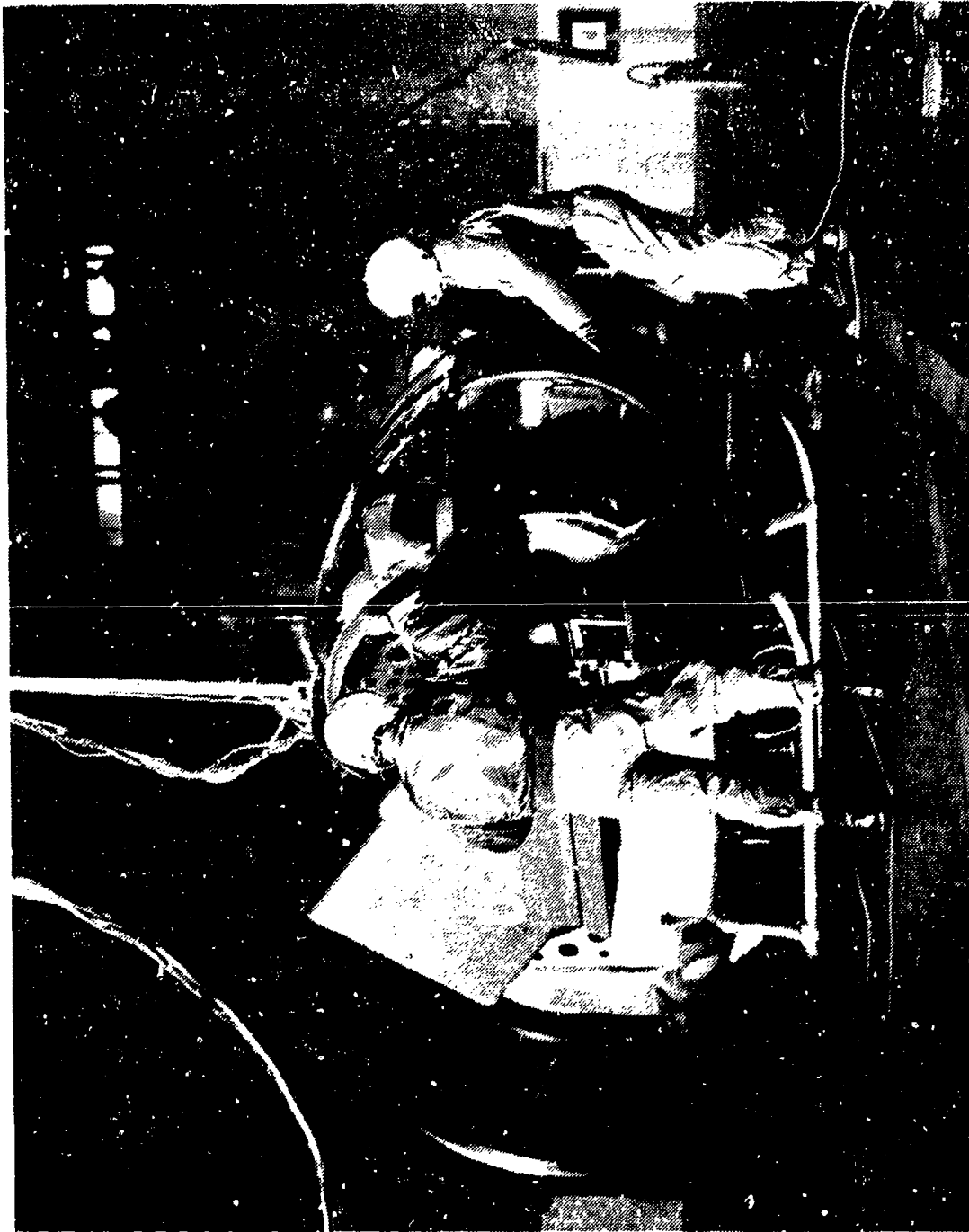

Figure 3.2.3.3.6 AiResearch STAMP Feasibility Demonstrator Vehicle in Tethered Flight (Courtesy AiResearch Manufacturing Co.)

due to Marine Corps budgetary constraints. It should be noted that prior to this, the Naval Weapons Center STAMP concept preference had already gravitated to the ejector thrust augmentation approach (see Section 3.2.3.4).

In consonance with the Marine Corps objectives, AiResearch's STAMP concept was aimed at providing a low-cost, short-range, vertical lift air vehicle for use by the basic tactical infantry unit. Specific design features and ultimate performance objectives included:

- Elimination of external rotors or aerodynamic surfaces.
- Two-man, enclosed, side-by-side seating.
- VTOL, hover and translational flight capabilities.
- 30 mile range at 75 mph maximum cruise speed.
- Simplicity of operation and control.
- Simplicity of service and maintenance.
- Low cost in production.

The ten-month contracted effort covered four work assignment areas: program management, coordination and documentation; preliminary design; fabrication and static test of a single demonstrator vehicle; and feasibility demonstration in tethered flight.

Information contained in the following paragraphs was obtained from References 3.2.12 and 3.2.13.

Description of the Vehicle: The lifting/propelling system of the vehicle is revealed in Figures 3.2.3.3.7 and 3.2.3.3.8. Fundamentally, this is a turbofan vectored thrust lift/cruise arrangement provided with only a limited amount of thrust vectoring (30 aft to 15° forward). The important features of the vehicle are:

1. A streamlined body containing a crew compartment, a turboshaft engine, fan, rear located air intake, ducting and thrust-producing nozzles.
2. Location of the fan near the rear of the body in an approximately vertical circular opening, propelling air from the rear towards the front of the vehicle.
3. A turboshaft engine with gear box to drive the fan.
4. A plate at the rear of the body mounted parallel to and spaced away from the fan opening to provide an annular entrance for the air.
5. A duct system with a series of turning vanes leading to two downwardly facing, rectangular nozzles, one at each side of the body.

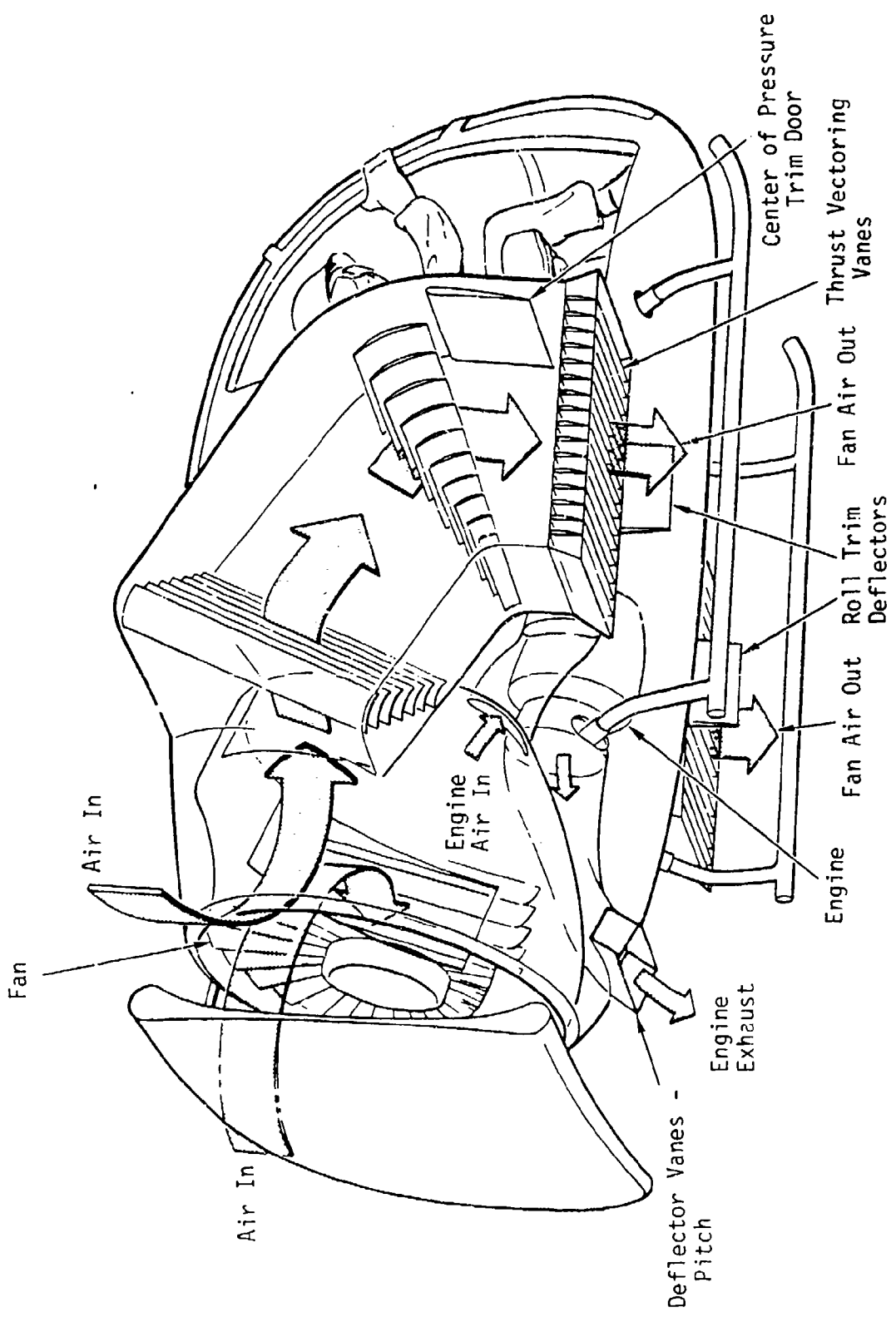

Figure 3.2.2.3.3.8 AirResearch STAMP Feasibility Demonstrator (from Reference 3.2.14)

6. Thrust vectoring vanes in the nozzle exits and means for moving them for vehicle yaw and fore-aft acceleration control.

7. Moveable surfaces (pressure trim doors) for adjusting (trimming) the thrust and longitudinal center of pressure of each nozzle.

8. Moveable surfaces (roll trim deflectors) for controlling the thrust of the nozzles for roll control.

9. Location of the engine exhaust in the belly of the body at its rear and use of moveable flaps on the nozzle to vector the flow up and down for longitudinal control.

10. A shock absorbing skid type landing gear.

Propulsion System: Power for the vehicle was provided by an AiResearch TSE 231 free turbine turbo-shaft engine rated at 474 shaft horsepower (S.L. standard day) and having a 0.605 lb/shaft hp/hr specific fuel consumption. Engine dry weight was 171 lbs. The engine was mounted in the airframe behind the cockpit as far forward as possible to place the c.g. near the occupants so as to minimize c.g. shift when operating with one or two people. Orientation of the engine was with air inlet facing the front of the vehicle and air was carried to the engine from a scoop on the duct wall located in the flow downstream of the fan. A second inlet provided air to an oil cooler. The engine exhaust was directed downwardly near the rear of the vehicle and used for pitch control. The gear box had a reduction of 7.46 to 1 and was located ahead of the engine air inlet. Going directly from the gear box was a shaft which drove the fan located in the air intake duct entrance at the rear of the vehicle, as shown in Figure 3.2.3.3.7. Fuel for the engine was carried in two tanks mounted near the vehicle c.g. below each side of the engine in the plane of the engine plenum. To save weight the engine was started by an externally powered hydraulic motor.

The fan was designed with a large annulus area (disc area outside of the hub) to minimize diffusion and duct wall friction losses and a relatively low blade loading was used to accommodate the geometric asymmetries in the fan inlet and discharge regions. Specific characteristics of the fan were:

TABLE 3.2.3.3.1

**AiRESEARCH STAMP VEHICLE FAN CHARACTERISTICS**

Type	Axial flow, fixed pitch
Fan Diameter	34.5 inches
Hub Diameter	14.2 inches
Number of Blades	15
Design Pressure Ratio	1.08 to 1
Design Mass Flow	103 lb/sec
Fan Efficiency (design)	85%
Input Horsepower	474
RPM	5800

Air was drawn in by the fan (Figures 3.2.3.3.7 and 3.2.3.3.8) through the annular opening at the rear of the vehicle with the back plate spaced away from the entrance lip by streamlined struts. To minimize ingestion of engine exhaust the lower one-fourth of the annular opening was blocked off. Aft of the fan, the main circular duct divided and blended into two rectangular side ducts which carried the air to each thrust nozzle. On entering the side duct, the air was turned 90° by an aerodynamic cascade and then turned another 55° before it entered the nozzle. Each nozzle had a set of controllable angle vanes which were designed to vector the airflow from 30° aft to 15° forward for forward propulsion, braking and yaw control. Each side duct contained an internal door at the forward wall, hinged transversely at the top, to change the nozzle area. The principal function of the door was to shift the nozzle center of pressure (c.p.) for longitudinal balance of the vehicle. Change in door position also affected nozzle thrust and it was found that the 80% open position, giving a 627 sq. in. total nozzle area, produced the highest thrust with the fan running at 5700 rpm (98% of maximum rpm).

Another device for controlling the thrust was a deflector plate, hanging below each nozzle next to the fuselage and hinged at the top. Movement into and out of the nozzle efflux was used to decrease and increase thrust for roll control. In neutral position, the plates were partially deflected so that differential movement produced roll with little loss in total nozzle thrust (vehicle lift). Total lift was controlled by engine rpm change.

Table 3.2.3.3.2 gives the predicted and measured propulsion system performance. Because the ground effect influence on this STAMP vehicle's vertical lift is unknown, the predicted and measured values cannot be compared reliably. Ground effect, it should be noted, can be either negative or positive depending on the body shape and the action of the gas flows on the ground and body. AiResearch predicted that the duct-nozzle system total pressure loss would be 8.96 inches of water (0.32 lb/sq.in.); the actual loss was about 9% higher. During the tether tests, the vehicle was hovered in

ground effect (landing gear skids 6 to 8 inches off the ground) at a 1092 lb weight using 585 horsepower. Engine exhaust gas temperature, when generating 1000 lb of primary nozzle thrust, was predicted to be 1160°F.

At 1000 lb thrust the primary nozzle area loading (disc loading) was 215 lb/sq.ft giving an efflux velocity in excess of 300 ft/sec.

TABLE 3.2.3.3.2

VERTICAL LIFT PERFORMANCE OF AIRRESEARCH STAMP VEHICLE

	Predicted (O.G.E.) <sup>1</sup>	Measured (I.G.E.) <sup>2</sup>	
Total Lift, lbs	1000	1092 <sup>4</sup>	925
Primary Nozzle Thrust, lbs	935	1027	863
Engine Nozzle Vertical Thrust, lbs	64	65	62
Fan Input HP	503 <sup>3</sup>	585	474
Fan Airflow, lb/sec <sup>5</sup>	105	111	103
Fan Thrust/HP, lb/HP	1.99	1.87	1.95
Fuel Flow, lb/min	5.25	5.83	5.17

- NOTES: Lifts and thrusts are totals available without adjustment for use in flight control.
- <sup>1</sup>O.G.E. - out of ground effect
  - <sup>2</sup>I.G.E. - in ground effect
  - <sup>3</sup>Maximum rated engine power
  - <sup>4</sup>Maximum weight hovered (in ground effect)
  - <sup>5</sup>Taken from propulsion system predicted performance curve

Airframe: (Figure 3.2.3.3.9) As noted earlier, the fore part of the body was taken from a Hughes/Army OH-6A helicopter. The aft airframe was constructed using conventional aluminum alloy semi-monocoque structure with a special effort made to obtain light weight and provide easy access to the propulsion components. Factors which entered into the design of the structure were the tether attachment load of 6 g, gyroscopic loads imposed by a 3.5 radians/sec pitch or yaw rotation, engine seizure and a general 2 g load factor. For accurate alignment of fan and engine, rigidity was obtained by a box beam structure connecting the bulkheads used for mounting the engine and the fan and for mounting of the fan drive shaft bearings. The OH-6A helicopter landing gear was retained but the skids were replaced with lighter ones to save weight.

Honeycomb sandwich and foam stiffened structure was used extensively in the turning vanes, doors, deflector plates and rear drag plate. The external surface materials were either thin aluminum sheet or fiberglass depending on the item and its use, with fiberglass being used

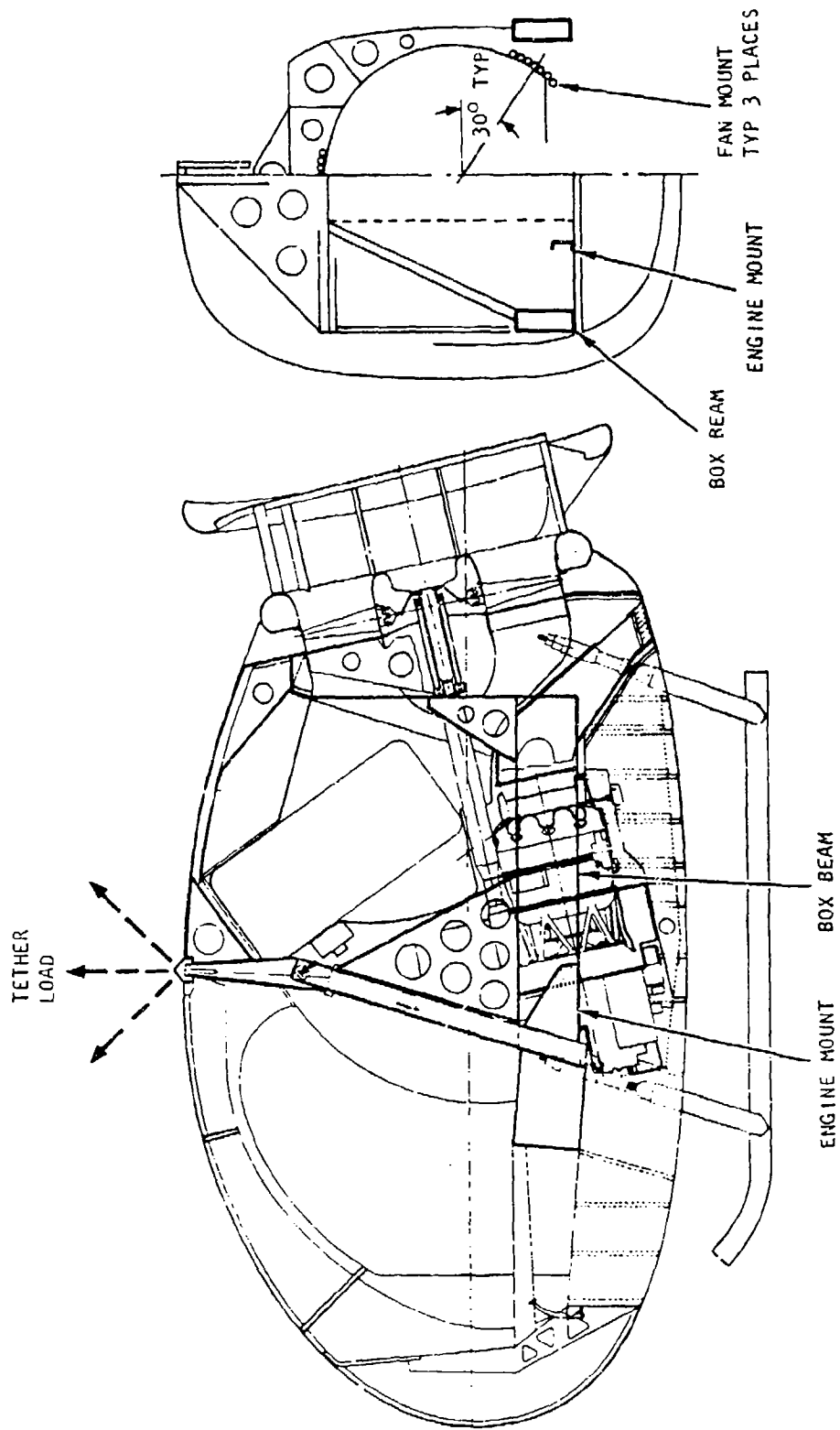

Figure 3.2.3.3.9 Schematic View of Structural Arrangement of AiResearch Feasibility Demonstrator (from Reference 3.2.14)

for the rear drag plate and duct walls. The fan was built with a titanium hub and aluminum blades and the drive shaft used steel.

Component weights of the vehicle were not available, however, the following was given in Reference 3.2.13 as the final weight of the demonstration vehicle:

Basic weight of vehicle with 10 gal. JP-4 fuel, 2 gal oil, instrumentation and other miscellaneous items	830 lbs
Operator	150 lbs
Passenger	<u>132 lbs</u>
TOTAL	1112 lbs

The weight of the actual demonstrator vehicle was substantially greater than the originally projected value of under 1000 lbs. It was believed by the Naval Weapons Center than an optimized vehicle, based on the AiResearch concept, would be less than half the size of the demonstrator. It should be noted that 10 gal. fuel permitted about 10 minutes of flight time.

Stability and Control Figure 3.2.3.3.10 shows the control system of the vehicle. All controls were mechanically actuated. Pitching moments were produced by deflection of the engine exhaust up and down via vanes at the exhaust duct nozzle. Rolling moments were from differential thrust of the two fan air nozzles obtained through use of the deflector vanes also shown in Figure 3.2.3.3.11 and yawing moments were created by differential fore-aft deflection of the exit vanes (cascades) in the fan air nozzles. The cockpit controls are shown in Figures 3.2.3.3.5 and 3.2.3.3.10. A single control stick with a shovel type handle was used for pitch, roll, yaw and thrust control. Conventional stick motions were used for pitch and roll. A twist grip (axis horizontal) controlled engine/fan rpm and thrust. Twisting the stick about its axis (vertical) was used for yaw. Thus, all control was done with one hand; there were no foot controls.

To keep from using the pitch control for trim and reducing the pitch control available from the engine exhaust, a separate means for longitudinally trimming the aircraft was used, a center of pressure trim door (Figure 3.2.3.3.8). Movement of this door shifted the nozzle longitudinal center of pressure (c.g.) to coincide with the vehicle c.g. The door was moved by turning a knob located on the outside of the forward duct wall (see Figure 3.2.3.3.3). With the single door used in each duct, an undesired characteristic was change in thrust with c.p. shift. If the vehicle development program had been continued AiResearch intended to place a second door at the

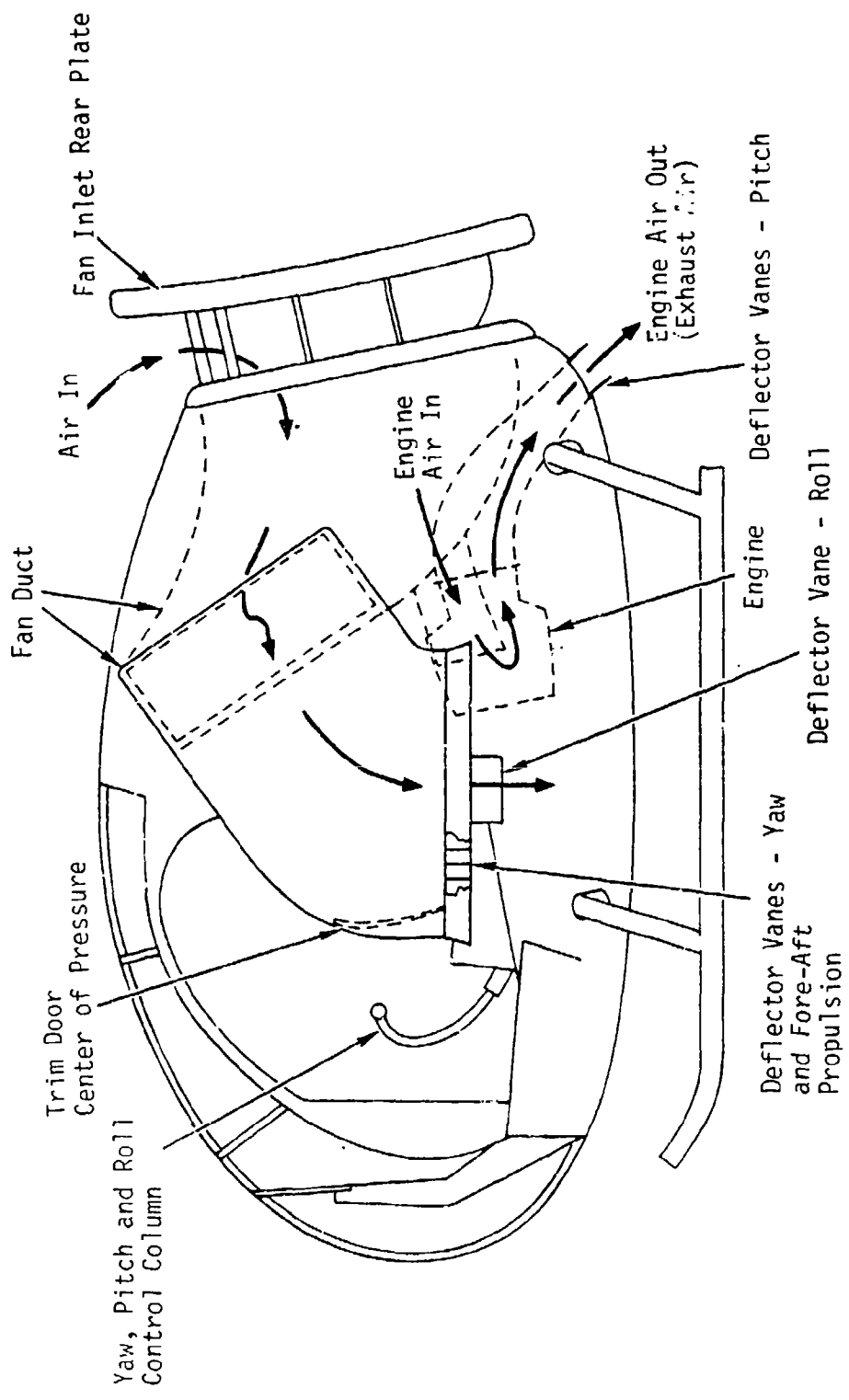

Figure . . 2.3.3.10 Control System - AiResearch STAMP Feasibility Demonstrator (from Reference 3.2.14)

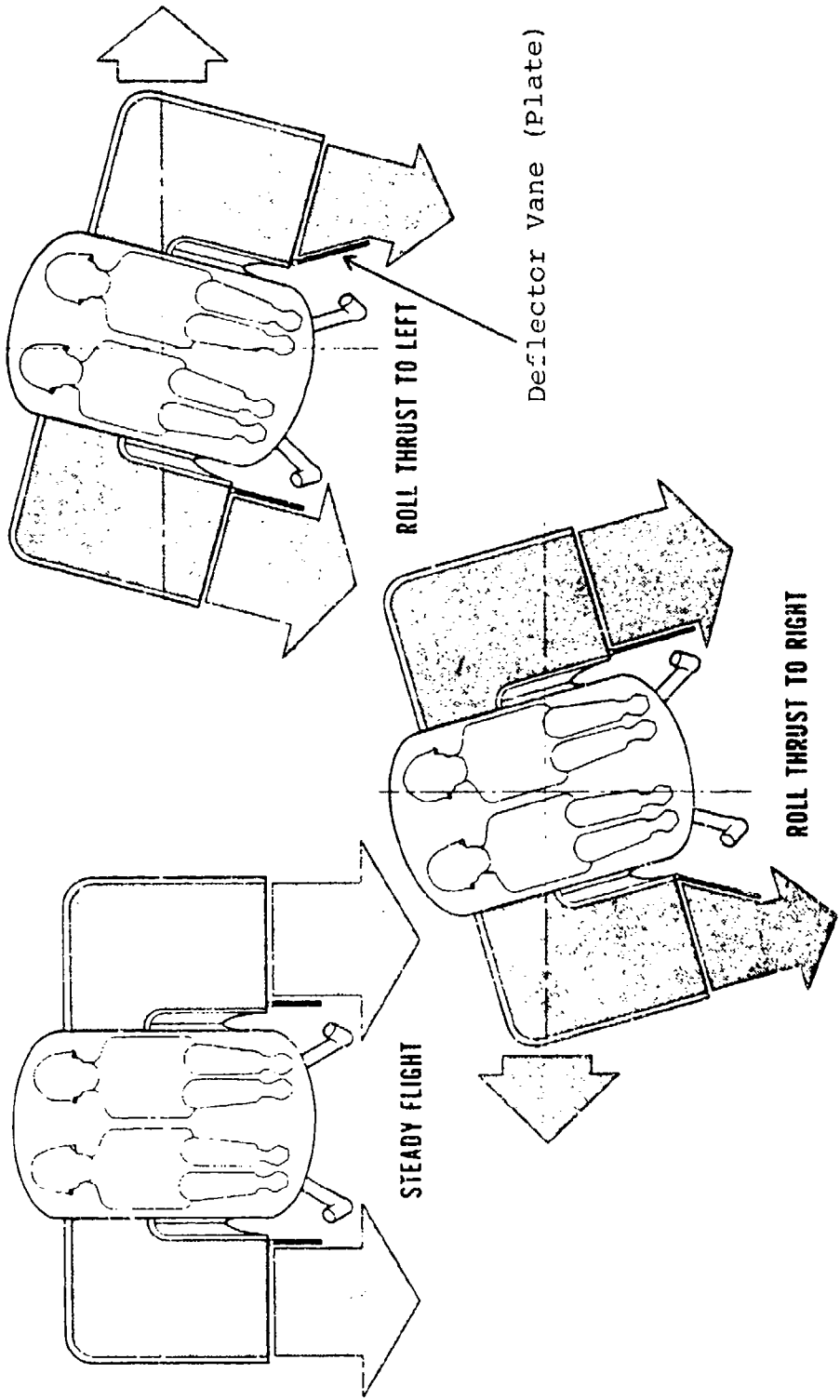

Figure 3.2.3.3.11 Method of Obtaining Roll Control - AiResearch  
STAMP Feasibility Demonstrator (from Reference 3.2.14)

rear of each duct to move in unison with the forward door, allowing the c.p. to be shifted without changing nozzle area and, hence, thrust. Differential adjustment of the doors would have been used to change nozzle area to obtain maximum thrust with the fan running at its normal operating rpm.

In an effort to maintain vehicle compactness, no vertical tail was used. Instead, directional stability was to be obtained through the use of the drag force acting on the rear of the body. Physically, this was accomplished by the plate shown in Figures 3.2.3.3.4 and 3.2.3.3.10 which acted as a baffle for the air being drawn in by the fan. Ram air momentum effects increased the normal drag forces of the plate in forward flight.

The flight demonstration vehicle had no stability augmentation system; however, because of their concern over the stability and control of the vehicle, AiResearch did perform a limited analysis using a computer and included human input via a control stick set-up. It was believed that artificial damping of the vehicle's motion about its pitch, roll and yaw axes would be necessary and the following stability devices were considered. (It should be noted that the Naval Weapons Center adamantly rejected the use of any stability augmentation system for STAMP vehicles):

1. Rotational damping of pitch and roll (by control stick deflection) using a pendulum displacement of a mass, the pilot and seat being used for this with pitch and roll pendular movement damped by a spring-dashpot system.

2. Gyroscopic feedback using engine gyroscopic moments for pitch and yaw damping inputs into the control stick.

3. Integrated engine throttle and control stick deflection to compensate for loss of lift with tilting (banking, pitching) of the vehicle.

4. Integrated roll-yaw control to provide coordinated turns.

For the computer analysis, full control displacements provided angular accelerations of 1.5, 0.6 and 2.0 rads/sec<sup>2</sup> in roll, pitch and yaw respectively for the vehicle resulting in corresponding damped responses of 1.8, 0.5 and 1.3 rads/sec for the simulated vehicle. The gain terms used for the feedback compensating devices were: for the seat pendulum, 1/4 rad/sec in pitch and in roll; for the gyroscopic engine deflection system, 3 rads/sec in both pitch and yaw.

Based on the simulated flights (with no stability augmentation system) using the computer, AiResearch concluded that:

Motion about the roll axis would be oscillatory with a frequency somewhat higher than that in pitch and yaw. Pitching motion would be lightly damped. Yawing motion also would be lightly damped in hover but stable with forward speed. In rearward flight the tail plate was destabilizing in pitch and yaw; the magnitude of this problem could not be determined without having more accurate data on the ram drag forces under such flight conditions. Both pitch and roll displacements of the vehicle caused translational accelerations and simultaneous loss of lift due to tilting of the vehicle which, it was believed, would make flight control difficult. In forward flight the tail plate drag was very stabilizing in pitch and yaw but made it difficult to hold a directional heading in sideward flight. This same effect existed in vertical climb and descent, hindering the performance of such maneuvers. No analysis of the effect of maneuvering in forward flight, e.g. sharp turns and terrain following was made.

AiResearch concluded that the seat pendulum and engine gyroscopic force deflections would provide some degree of stabilization but that limits of physical movement and force levels would not result in a completely stabilized vehicle. The integrated control functions which were examined could not be made compatible for all flight conditions and it was believed that, for satisfactory handling qualities, the control arrangement used would require the integrated functions to be non-linear with flight mode and control position.

Based on the analytical study, the controllability of the demonstrator vehicle was found to be marginal with the control system used but sufficient to maintain control for small input commands. This was borne out by the tethered tests where hover, limited forward translation, turning over a spot and vertical landing were demonstrated. It was found that thrust control (engine rpm response), was satisfactory and that yaw control was adequate. Pitch and roll control were found to be limited.

AiResearch concluded further that, to improve the design of a future vehicle, it would be necessary to:

1. Define the momentum drag forces fully through wind tunnel testing.
2. Do studies "to determine placement of the main and auxiliary thrust vectors to provide more inherent vehicle stability, independent of control functioning and/or any stabilization device incorporated."
3. Possibly separate the main and control thrust elements.

4. Determine the "specific handling qualities desired for a STAMP type vehicle peculiar to it as distinguished from conventional aircraft and helicopters."

Concluding Observations:

1. The primary purpose of the AiResearch effort was to "demonstrate the feasibility of their STAMP vehicle concept in tethered flight." Specifically, the vehicle was to be capable of controlled, free hovering flight with two people aboard (the tether was used for safety purposes only). The vehicle did meet the requirements of the contract by hovering (in ground-effect) with two people aboard and being controllable. Such a demonstration does not establish the feasibility of the concept, however.

2. With regard to the ultimate performance objectives listed near the beginning of this section (3.2.3.3) there is no question that an AiResearch type vehicle could be made to hover O.G.E. and perform translational flight under satisfactory control. The fuel flows during cruising flight, between 5 and 6 lb/min for the demonstrator vehicle, indicate that it should be possible for this type of vehicle to meet the 30 mile range requirement. Also, the 75 mph cruising speed should be attainable.

3. The AiResearch feasibility demonstrator vehicle did not provide answers to the question --can such a vehicle be built to have: "simplicity of operation and control, simplicity of service and maintenance and low cost in production?"

4. The STAMP requirement called for an empty weight which could be handled (stevedored) by three men, 450 to 500 lbs being the limit. Obviously, the AiResearch demonstration vehicle, with about a 770 lb empty weight, was not intended to satisfy this requirement. Whether an optimized AiResearch type vehicle could be built to weigh less than 500 lbs is an open question. For such an optimized STAMP the company intended to develop a new, lighter weight turboshaft engine. Considering that the flight demonstrator's engine weighed 171 lbs dry, it would be necessary to reduce weight elsewhere as well, that is in the airframe and other parts of the propulsion system. This could prove to be a difficult job since the flight demonstrator airframe already represented a serious effort to reduce airframe weight.

5. The flight demonstrator vehicle experienced positive ground effect (skids 6 to 8 inches above ground). However, on the basis of past experience a suck down effect could be possible out-of-ground-effect because the primary nozzle effluxes, located at the fuselage sides, can be expected to generate negative pressures over the belly.

6. The T/W for thrust-only-supported operational vehicles, to provide adequate maneuverability in forward flight, is presently not known but, obviously, it must be well in excess of 1.0 (see Concluding Observations at end of Section 3.2.3.2.2). Such T/W values improve handling qualities in hovering flight but, conversely, lead to increased design empty weight for a given VTO payload-range mission.

7. The use of a momentum drag plate at the rear of the vehicle for stabilization is novel and does permit a shorter, more compact vehicle than one with a conventional tail. As recognized by AiResearch there are detrimental characteristics. Unlike moveable conventional tail surfaces, the drag plate forces and moments cannot be changed in flight. The drag plate acceptability is unknown and would require further investigation.

8. Despite the successful demonstration of control in hovering, the adequacy of the control system was not established. AiResearch recognized the need for more development work to improve control effectiveness particularly in pitch and roll.

9. An all-mechanical control system was used for simplicity and reliability. Such a system does have the drawback of relative inflexibility in handling changes in operation required by different flight modes, hover through high speed. Modifications to make the controls more satisfactory could lead to a more complex system.

10. From an operational standpoint three characteristics of the AiResearch concept are of concern when flying in ground effect.

a. The effect of the high velocity efflux (over 300 fps) on unprepared ground in dislodging and propelling debris outwards.

b. The upflow at the body (fountain effect) produced by the downwash from the two primary nozzles. This will entrain dust and debris some of which could enter the fan intake. Also this may affect the dust signature of the vehicle.

c. The possible incendiary effect of the hot (1000°F plus) exhaust gases impingement on the ground. It is possible that the high velocity flows from the primary nozzles will act to prevent any problems but this would have to be verified.

### 3.2.3.4 Naval Weapons Center Ejector Thrust Augmented STAMP and Alperin Jet-Diffuser Ejector Propulsion System (1974-1976)

The third approach to STAMP, and the one considered to be the most promising by the NWC, was the use of an ejector thrust augmenter (ETA) propulsion system. Such propulsion systems have been applied to V/STOL aircraft such as the Lockheed "Hummingbird" (XV-4A) and the North American Rockwell XFV-12A and are to be discussed in a later section of this report. The NWC interest in a STAMP vehicle, with the ETA integrated into the vehicle body, was an outgrowth of their 1971-1972 Proposed Technical Approach (PTA) studies (Reference 3.2.7) to minimize infrared emissions, noise and surface erosion of the Williams and All search vehicles through incorporation of ETA devices. Theoretical ETA studies, funded by the Marine Corps, led to a \$250,000 contracted effort in 1974 with the Flight Dynamics Research Corporation (FDRC) of Van Nuys, California to explore the ETA systems desired. The FDRC, headed by Dr. Morton Alperin, had been deeply involved in developing high performance, compact ETA's.

Vehicle Configuration: While others had, in the past, investigated the use of thrust-augmenting ejectors for individual lift devices, e.g. Sud Aviation's rocket-powered "Ludion" (Figure 2.3.2.3) and J. Bertin's turbojet powered vehicle (Figure 3.2.3.4.1), the NWC concept featured a different configuration and type of ejector. During the conceptual period, the NWC performed preliminary design work on several different vehicles with open and closed bodies and with different ejector arrangements, all using the hot gas efflux from a turbojet engine as the power source. Figure 3.2.3.4.2 is a three-view drawing of one enclosed body version with twin, multiple chamber, rectangular ejectors. A later version, with single chamber ejectors, is shown in Figure 3.2.3.4.3. In these designs the ejectors were located at the sides near the top of the body and extended over its full length. A short depth was desired to keep the nozzle exit as high above the ground as feasible. Pitch, roll, yaw control and forward propulsion were to be provided by the ejector system. Hot gas was to be pumped into the ejector by a centrally located engine with its intake facing forward and its exhaust flowing into the duct system surrounding the ejector box. To meet the operationally-required limits on size and empty weight, it was necessary to use a relatively high thrust-to-weight gas generator and an ejector with a thrust augmentation ratio of about 2. Of the several turbojet engines available, the NWC selected a NASA-developed engine because it had the necessary thrust (670 lbs), weight (145 lbs), tail pipe pressure (25.4 psia), and size (12.5 in. dia., 30 in. length) for the STAMP design being considered as a potential demonstrator vehicle.

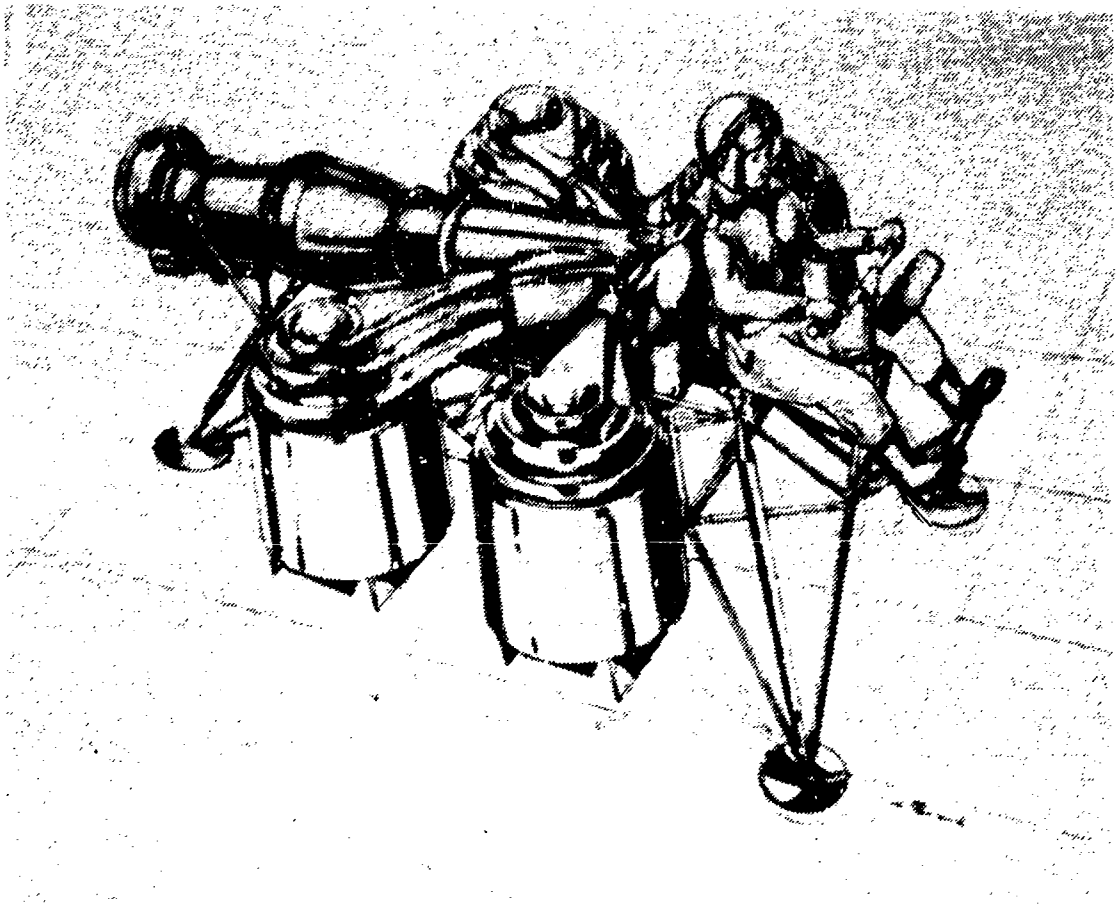

Figure 3.2.3.4.1 J. Bertin (France) Concept of a Small Lift Device (from AGARD AGARDograph 46, Part I, June 1966)

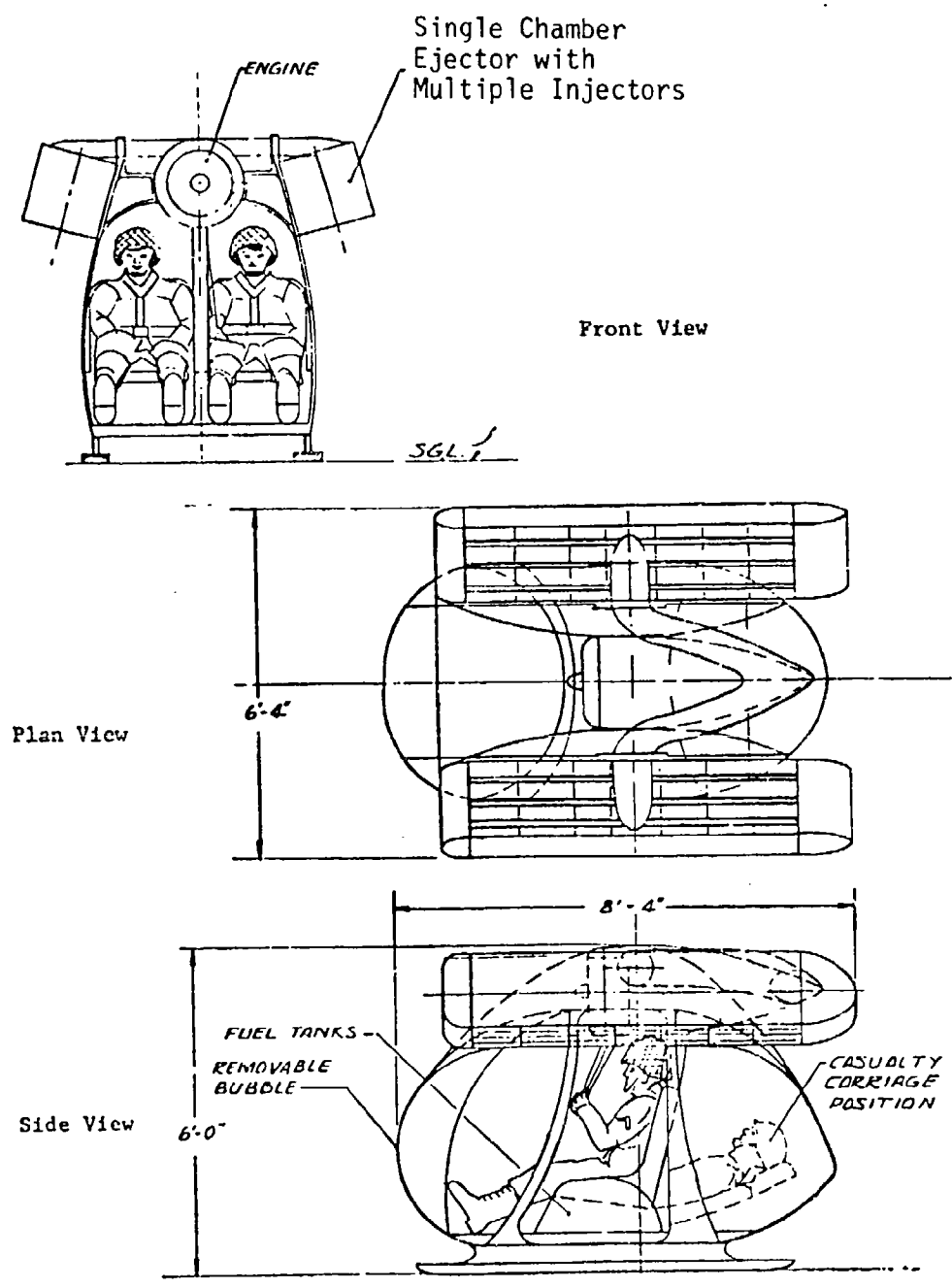

Figure 3.2.3.4.2 Naval Weapons Center Twin ETA (Twin Chamber) STAMP Vehicle Concept (Courtesy Naval Weapons Center)

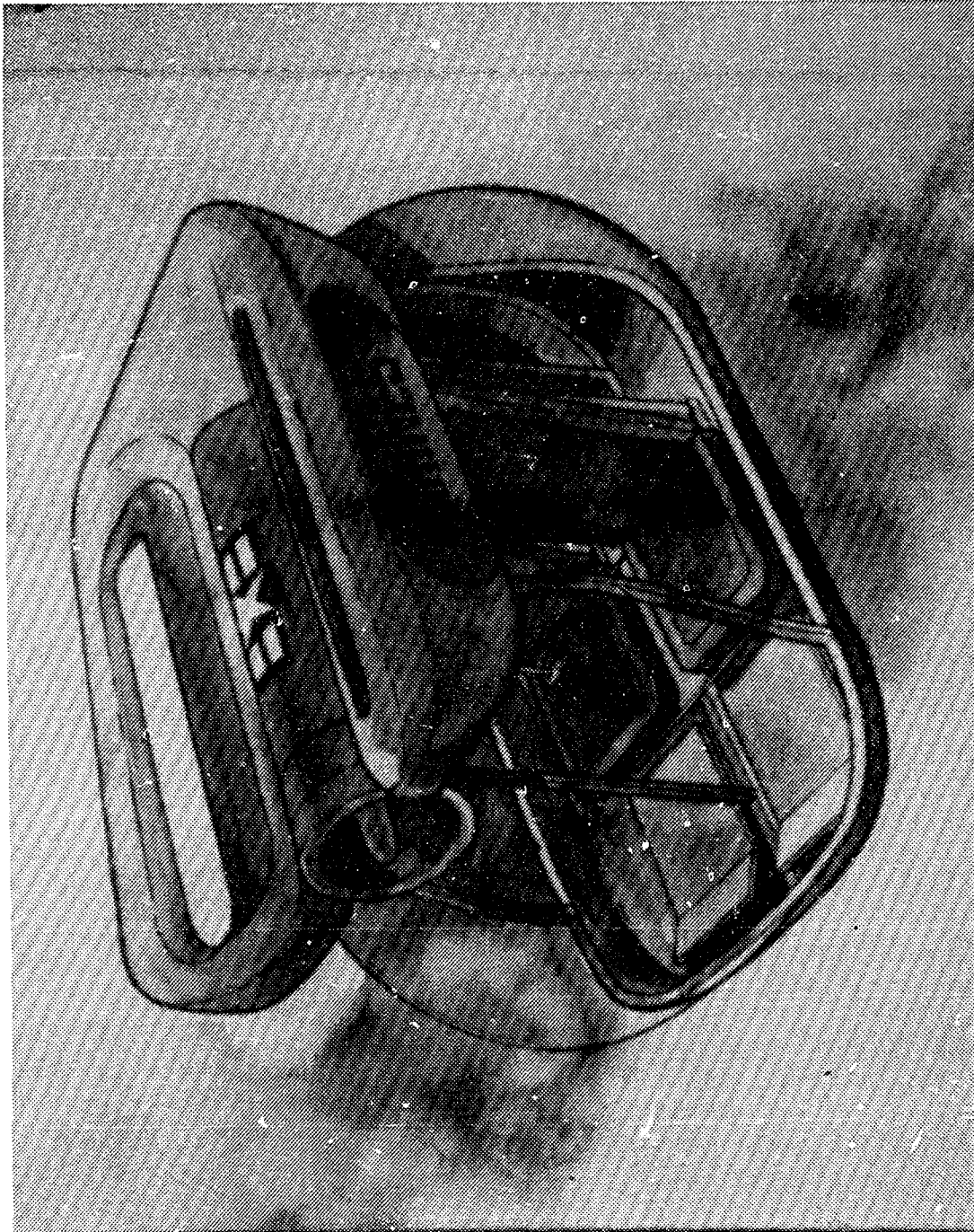

Figure 3.2.3.4.3 Naval Weapons Center Twin ETA (Single Chamber) STAMP Vehicle Concept  
(Courtesy Naval Weapons Center)

No specific information on this proposed vehicle was available regarding design features, weights, propulsion system, control method or performance.

Ejector Types: Initially, it was proposed to obtain the short depth of the ejector by using a Coanda/Jet Diffuser Ejector (C/JDE), shown in cross-section in Figure 3.2.3.4.4. Illustrated alongside, for comparison, is a typical high performance ejector (generally similar to that used on the (XV-4A), containing a series of nozzles protruding from supply ducts  $P_p$  (primary flow plenum), a flow mixing region and a long, small-angle diffuser, necessary to expand the high velocity mixed flow to obtain increased thrust. The diffuser length is determined by the nozzle-to-throat area ratio desired and by the permissible angle of the walls, this angle being limited by the flow separation problem. In the C/JDE approach, a continuous slot nozzle injects a sheet of air tangentially to the ejector lip. The flow follows the curved wall due to the Coanda effect and entrains ambient air to increase mass flow. A second, slot-type nozzle, blowing tangentially near the bottom of the chamber produces a skewed jet sheet which acts like a solid wall diffuser. With a solid wall diffuser, divergence angles are limited to about 12 to 14 degrees between the walls; the jet diffuser value used was 90°.

Laboratory tests of the C/JDE by the FDRC revealed that this ejector produced only a small thrust augmentation, the primary, Coanda flow having a poor secondary flow entrainment and mixing (energy interchange) capability. To eliminate this deficiency, Dr. Alperin invented a new arrangement as shown in Figure 3.2.3.4.5 (from Reference 3.2.15) where the primary flow system was completely separated from the ejector box. Figure 3.2.3.4.6 shows the Alperin Jet Diffuser Ejector (AJDE) in three-dimensional form. Test results of a 4 in. throat, 4 in. diffuser length ( $L/W = 1.01$ ) AJDE, using cold flow, showed it to have a thrust augmentation\* of 2.1 statically and 2.6 at 66 fps forward speed. Reference 3.2.16 showed that an equivalent advanced ejector (1972) with solid diffuser walls (Figure 3.2.3.4.4) produced a static thrust augmentation of 1.98 but required a  $L/W$  of 4.5. This included a uniform mixing region which is not required by the Alperin Jet Diffuser Ejector. Further, because of the simple slot type nozzles used, the AJDE is physically less complicated than other high performance ejectors which normally use a multiplicity of separate nozzles.

Vehicle Control: The specific method and mechanics of the control and stabilization system for the NWC

---

\* Thrust Augmentation = Total thrust of augmented system/theoretical thrust available from the total injected flow at the same jet power (including that of jet diffuser).

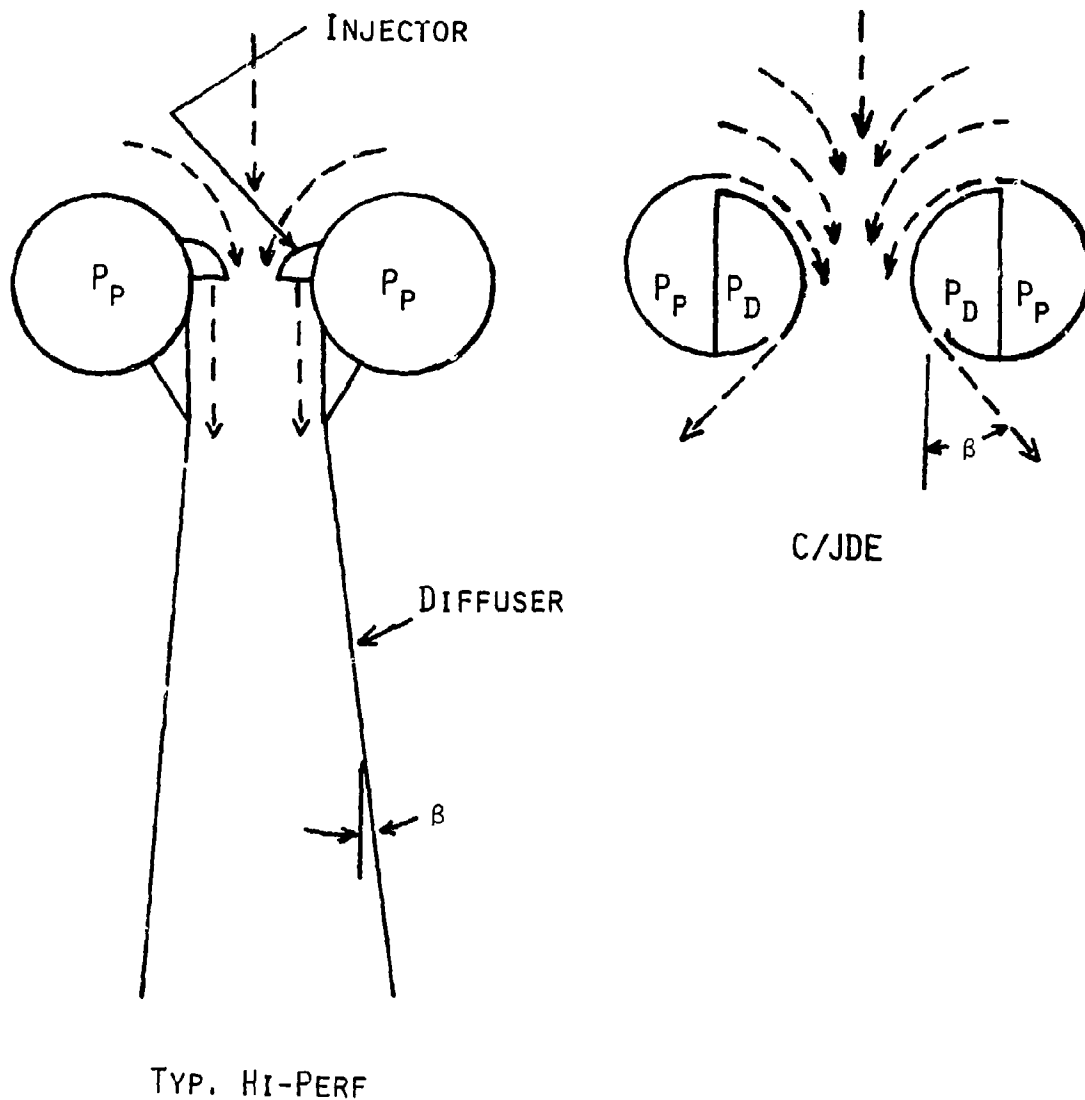

Figure 3.2.3.4.4 Configuration Comparison--Coanda/Jet Diffuser Ejector and Typical High Performance Ejector (from Reference 3.2.15)

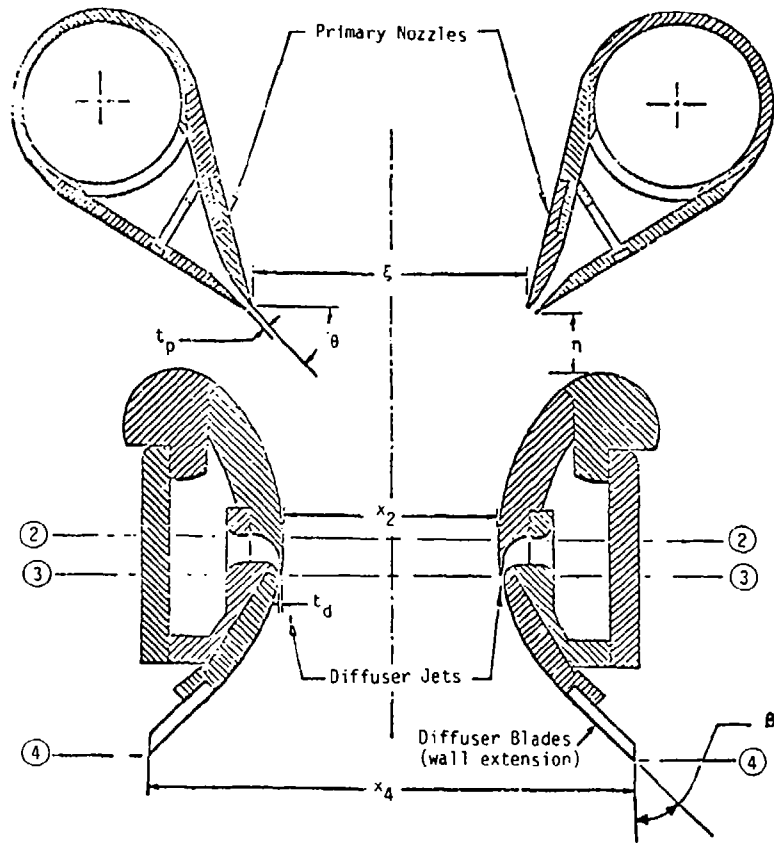

Figure 3.2.3.4.5 Alperin Jet Diffuser Ejector - In Cross Section (from Reference 3.2.14)

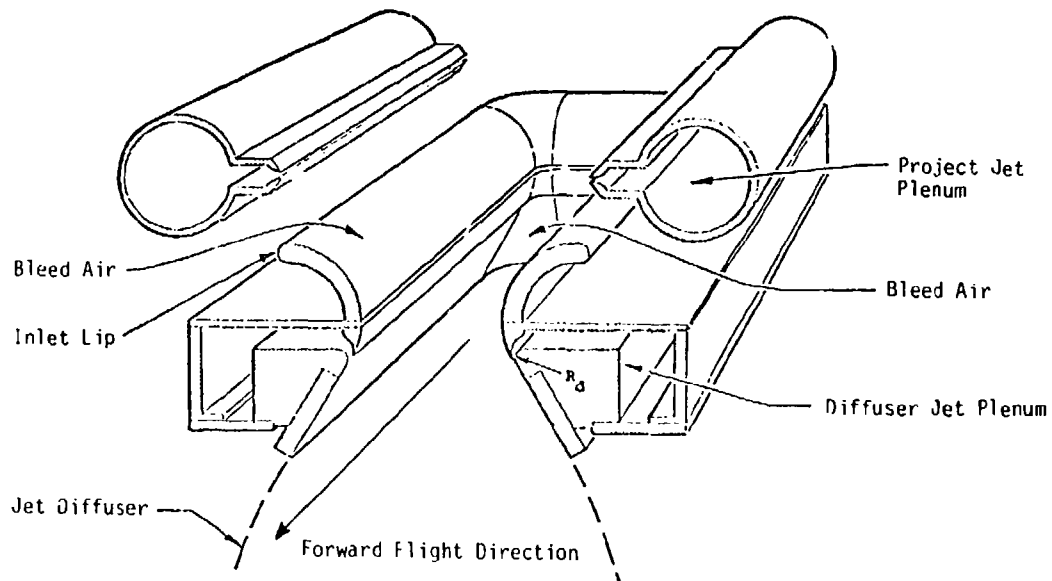

Figure 3.2.3.4.6 Elements of Alperin Jet Diffuser Ejector (from Reference 3.2.15)

ejector-equipped STAMP vehicle are not known, however, some information on control is provided in Reference 3.2.14. An objective of the control system used was to provide control forces and moments with a minimal loss of total lift force. The FDRC suggested that there were a number of approaches to varying the ejector's total thrust, thrust distribution and thrust vector angle. Changing thrust distribution fore and aft of the vehicle c.g. would pitch the aircraft and change in thrust between left and right ejectors would produce roll. Lateral tilting of the thrust vectors could produce side force on the vehicle, without the use of roll, and also be used to provide yawing forces. The FDRC believed that a number of methods were available for controlling the forces produced by the ejectors. Among these were:

1. Variation of primary slot width between the front and rear segments of the ejector, to produce a change in longitudinal thrust distribution about the c.g. for pitch control.

2. Differential change in primary slot width between left and right augmenters to produce rolling forces.

3. Asymmetric change in diffuser blade length (shown in Figure 3.2.3.4.5) to tilt the thrust vector. When done uniformly from front to rear, a side force would be generated in the vehicle and when done differentially between front and rear parts of the ejector, the side forces would produce yawing moments.

4. Asymmetric variation of the diffuser slot width to provide similar action to that of diffuser blade length change.

5. Asymmetric variation of diffuser blade angle to produce thrust vector tilt.

6. Fluidic control by asymmetric variation of diffuser or primary plenum pressures.

Using the test apparatus, the FDRC investigated two of the methods for changing the ejector forces-- variation in primary slot width and asymmetric change in diffuser blade length. The tests showed that force strength and lateral inclination could be changed effectively with reasonable variations in slot width and diffuser blade length, with little loss in ejector thrust augmentation. However, the capability of these force changes to provide satisfactory control for the NWC STAMP vehicle was not determined, leaving open the question regarding adequacy of the testing performed. Also, it should be noted that these tests were made on an isolated ejector under static (hover) conditions. No tests

were made with the ejector mounted on a STAMP body to determine its effect on lift and control.

No information was available concerning the method proposed to obtain forward propulsion on the NWC STAMP equipped with the Alperin Jet Diffuser Ejector.

Concluding Observations:

1. The augments approach to increasing the static thrust of a turbojet engine has definite advantages in simplicity (fewest moving parts) and in arrangement of the thrust producing areas since these can be arbitrarily shaped and disposed well around the STAMP vehicle body.

2. The Alperin Jet Diffuser Ejector achieved an outstanding thrust augmentation ratio (2.1 static) in a very short depth and appears to be a most promising approach to an augments system for a VTOL device (including some types of VTOL aircraft based on ejector thrust augmentation).

3. The increase in thrust augmentation with forward speed (to 2.6 at 66 fps) adds additional merit to the Alperin augments since it could benefit the maneuvering capability of the vehicle (see observations regarding the Williams WASP vehicle, 3.2.3.2.2).

4. The tests on the AJDE augments were done with cold primary flow on small segments of an isolated augments, using non-flight-weight hardware. Drag forces were not measured. The actual thrust augmentations on a flight vehicle may differ from the laboratory values when hot gas is used and vehicle body interference effects are present. The effect of hot gas flow on thrust augmentation, whether it is increased or decreased, remains to be resolved. It is expected that the vehicle body's effect will decrease the net static thrust of the augments out-of-ground-effect.

5. In forward flight, the drag forces (parasitic and momentum) will require forward tilting of the thrust vector, reducing the force available for lift. It would be well to measure these forces (and moments) during testing to help design the vehicle and determine its flight characteristics.

6. Another factor affecting the thrust augmentation value obtained is the effect of the ejector flow on the body (fuselage). Out-of-ground effect, negative pressures are expected over the belly which could result in decreased net thrust augmentation. In-ground-effect, positive pressures are expected which should increase vehicle net lift.

7. Maneuverability in forward flight will be an important factor in the vehicle design as it is with all of the wingless lift devices. Also the vehicle aerodynamic characteristics are expected to be an important area needing more investigation since they will affect flying qualities, the stabilization system needed (if any) and pilot skill required.

8. The adequacy of the control capability of the AJDE augments needs to be examined against the control powers required for the STAMP type vehicle envisioned.

9. While the turbojet engine used with the ETA system may be less expensive than an equivalent turbofan system, it still will be an expensive power plant if based on current (1980 technology). Development of a low-cost turbojet engine may be essential to the procurement of this, or any other, STAMP vehicle.

10. Despite the outstanding results achieved by the AJDE thrust augmenters in the laboratory, interest in this or any other augmenters can be expected to be dampened by the bad experience with previous augmenters-equipped aircraft such as the XV-4A and XFV-12A. In both of these the augmentations obtained in the actual vehicles were well below those achieved with laboratory apparatus.

### 3.2.3.5 Piasecki Aircraft Company Preliminary Design Study (1973)

It should be noted, at the outset, that this design study was sponsored solely by the Naval Air Systems Command and that there was little participation in this effort by either the Marine Corps or the Naval Weapons Center. Since "STAMP" was specifically a Marine Corps acronym, its use in connection with the Piasecki concept is not really correct.

Actually, with its disc loading of about 100 lb/sq.ft, the Piasecki Aircraft concept properly falls under the ducted propeller category of V/STOL Aircraft (Figure 1.13). However, it is better to include the concept here to provide a perspective on this approach in the light of the previously covered Marine Corps/Naval Weapons Center STAMP development efforts.

The primary objective of the effort was to determine the feasibility of a relatively low cost vehicle based on less costly engines than turbines, specifically the rotating combustion (Wankel) type engine under development by the Curtiss-Wright Corporation. Piasecki Aircraft concluded that the STAMP operational capabilities specified by the Marine Corps could be met with a rotating combustion (RC) engine-ducted propeller approach and that a target cost of about \$25,000 (1973 dollars) could be achieved in quantity production (about 10,000 units). This included all production non-recurring costs, but no research and development. The company made preliminary layouts and did general configuration studies on a number of arrangements which varied from those using a single ducted propeller through those with twin tandem, three and four ducted propellers. Most of the designs used Curtiss-Wright RC engines projected to the 1980 time period and the number of engines was varied from one to four. For comparison purposes some of the designs also were made using reciprocating and turbo-shaft engines.

Within the size constraints dictated by the objective of carrying several STAMP vehicles inside of a CH-46 helicopter (door width 72 in., height 72 in.); the Piasecki approach taken was to provide as much ducted propeller disc area as feasible for vertical lift. Duct disposition (number, placement and angle) was evaluated from the standpoint of vertical lift and forward propulsion effectiveness, control during all flight modes and placement of pilot and passenger. Consideration also was given to the problem of making safe landings after loss of an engine.

The requirements used were those established in Reference 3.2.9 and listed in Table 3.2.3.3 but with a few additional changes, resulting from Navy and Marine Corps meetings with Piasecki personnel. (Although the Marine Corps

did not participate in the study they did provide information to Piasecki.) The values used by Piasecki are given in Table 3.2.3.5.1.

Reference 3.2.17 provided the information on the Piasecki study which was constrained to an examination of several concepts based on shaft-driven ducted propeller propulsion. Use was made of the company's background and knowledge related to ducted propeller systems, specifically the "Aerial Geeps" developed for the U.S. Army, the Ring-Wing PA-22 (Reference 3.2.18) and the ducted tail rotor of the Piasecki compound helicopter Model 16H-1B (Reference 3.2.19).

TABLE 3.2.3.5.1

PRIMARY REQUIREMENTS USED BY PIASECKI AIRCRAFT  
IN THE PRELIMINARY DESIGN

Maximum Speed	38 mph acceptable; higher desired
Hover Altitude	3000 ft at 91.5°F, out of ground effect
Range	15.5 statute miles with 20% fuel reserve
Payload	500 lb (observer, passenger, normal fuel, mission tools or miscellaneous cargo)
External Dimensions (Maximum)	Length 95 in Width 62 to 66 in. (without floats) Width 96 in. with floats inflated) Height 69 in.
Emergency Landing	Absorb 16.67 fps sink rate
Mission Reliability	95% for 30 minute operation 98% once airborne
Expected Operating Time	120 to 150 hrs/month (6 hrs/day)
Noise	No audible detection beyond 500 meters at 100 ft altitude (above terrain) and at 50 to 70 mph
Downwash	Must not necessitate mats to protect ground
Cost Target/Vehicle	\$20,000 in high production

Rotating Combustion (RC) Engine: Rotating combustion engines were used because these were expected to have the following advantages over a conventional aircraft type reciprocating engine:

1. Light weight
2. Small size
3. Design simplicity
4. Operating smoothness
5. Low noise
6. Ready growth potential by stacking of rotor units
7. Stratified charge combustion capability
8. Control of exhaust emissions to obtain a low infrared output.

Advantages over the turbine were expected to be:

1. 2/3 to 1/2 lower purchase cost
2. 1/4 lower cruise fuel consumption
3. 1/3 lower loiter fuel consumption
4. 3/4 less hot day power loss
5. 2/3 to 1/2 lower overhaul cost
6. Simplicity regarding training, maintenance, repair
7. Throttle response equal to reciprocating engine
8. Easier infrared shielding
9. Easier noise suppression
10. Greatly reduced foreign object damage problem.

(Note: At the time of the Piasecki study (1973), it appeared that RC engines for automotive and marine use would be in substantial quantity production (50,000/yr) by the 1980's. Components of these could be used to build the vehicle engines.)

In the initial group of vehicles, it was proposed to use unsupercharged, liquid-cooled RC engines because these were being developed first by Curtiss Wright. Later, when available, aircooled engines would be considered because they would be lighter and eliminate the cost and complexity of the liquid cooling system (radiators, piping, coolant).

Curtiss-Wright projected that the power-to-weight ratios of the liquid cooled RC engines for the vehicle (250 to 500 horsepower) would reach 1.7 to 2 horsepower per pound by 1980. This is nearly equal to the values found in turboshaft engines.

Configuration Selected: Analysis and comparison of the various vehicle configurations resulted in the selection of the highly angled, four-duct arrangement with

tandem seating (Figures 3.2.3.5.1 and 3.2.3.5.2) because it provided the following combination of merits:

1. Positive pitch and roll control moments.
2. Availability of a large forward thrust component for forward flight.
3. Minimum interference of pilot and passenger with duct inflows.
4. Full balance of propeller torques due to symmetry of the four-duct arrangement.
5. Position of the c.g. near the vehicle midpoint permitted a more optimum location of crew and equipment.
6. Smaller overall size than a two-duct configuration.
7. Permitted symmetrical, centerline location of engine.

Duct axis angles, referenced to the horizontal, were  $+20^\circ$  for the front and  $+30^\circ$  for the rear ducts. This led to required exit flow deflections of  $70^\circ$  and  $60^\circ$  respectively in hover, or somewhat less if the nose was pitched up,  $5^\circ$  to  $10^\circ$  being considered normal. This large turning of the flow entailed thrust losses, estimated by Piasecki to be about 18%, resulting in a higher hover power requirement than that for ducts with little or no inclination from the vertical. Conversely, there are important benefits from near-horizontally (thrust axis) oriented ducts. In forward flight these are: the use of the ducts as ring wings; elimination of the momentum drag characteristics of vertical ducts; and the efficient use of the propeller thrust.

#### Recommended Vehicle (Model 159B):

Illustrations of this vehicle are shown in Figures 3.2.3.5.1, 3.2.3.5.2 and 3.2.3.5.3. Both single and twin RC engine arrangements were evaluated and, for safety reasons, the latter was preferred. A layout with a single, aircraft-type reciprocating engine (an eight cylinder, 450 hp, horizontally opposed Teledyne Continental) also was made for comparison purposes. The higher weight of this engine, 513 lb vs. 218 for an equivalent RC type, seriously reduced the associated vehicle capability below that of the RC-equipped machine. Primarily affected were payload, vertical rate of climb, hover ceiling and range.

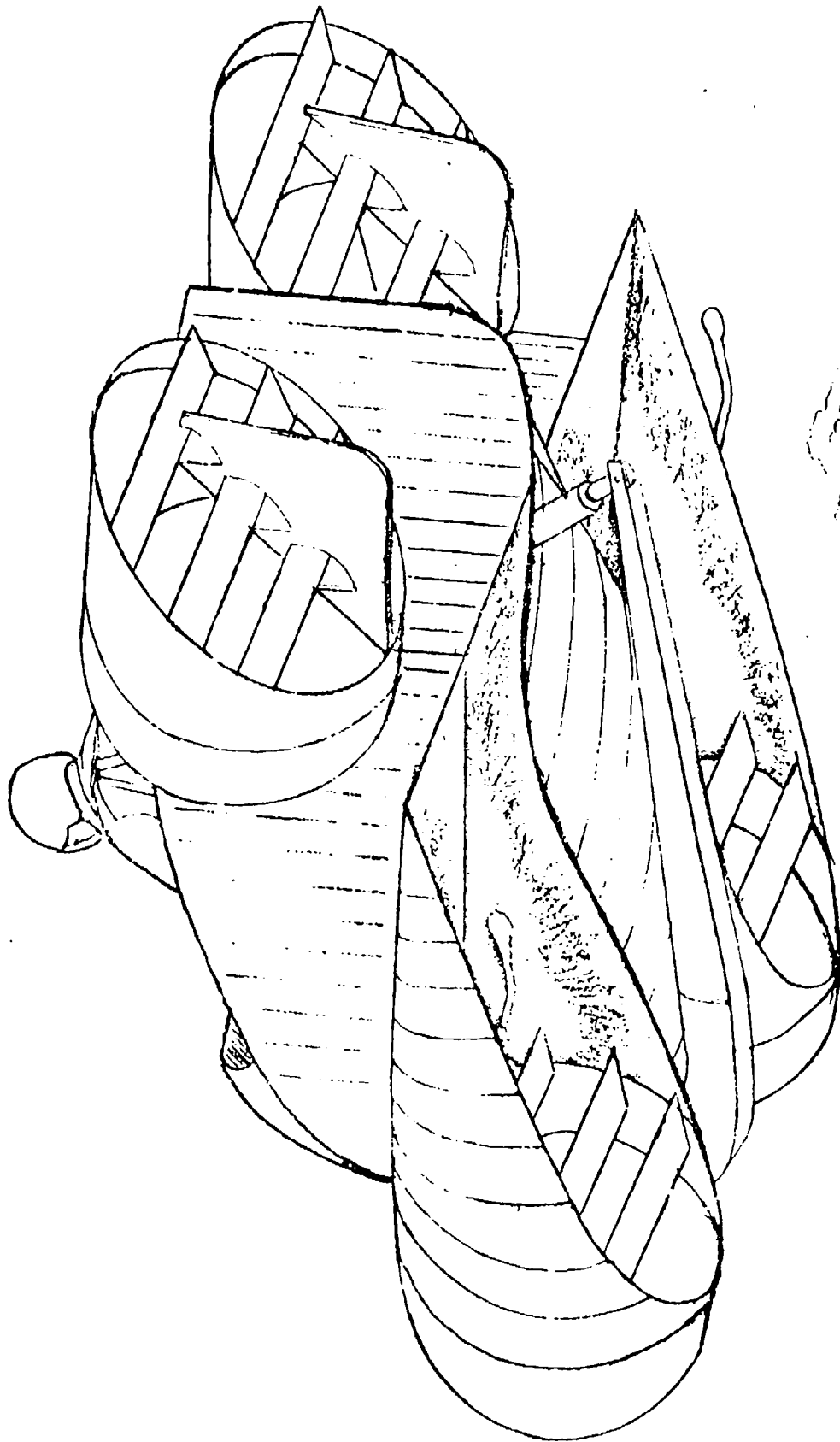

Figure 3.2.3.3.5.1 Piasecki Aircraft Model 159B STAMP Design,  
Bottom Rear View (from Reference 3.2.17)

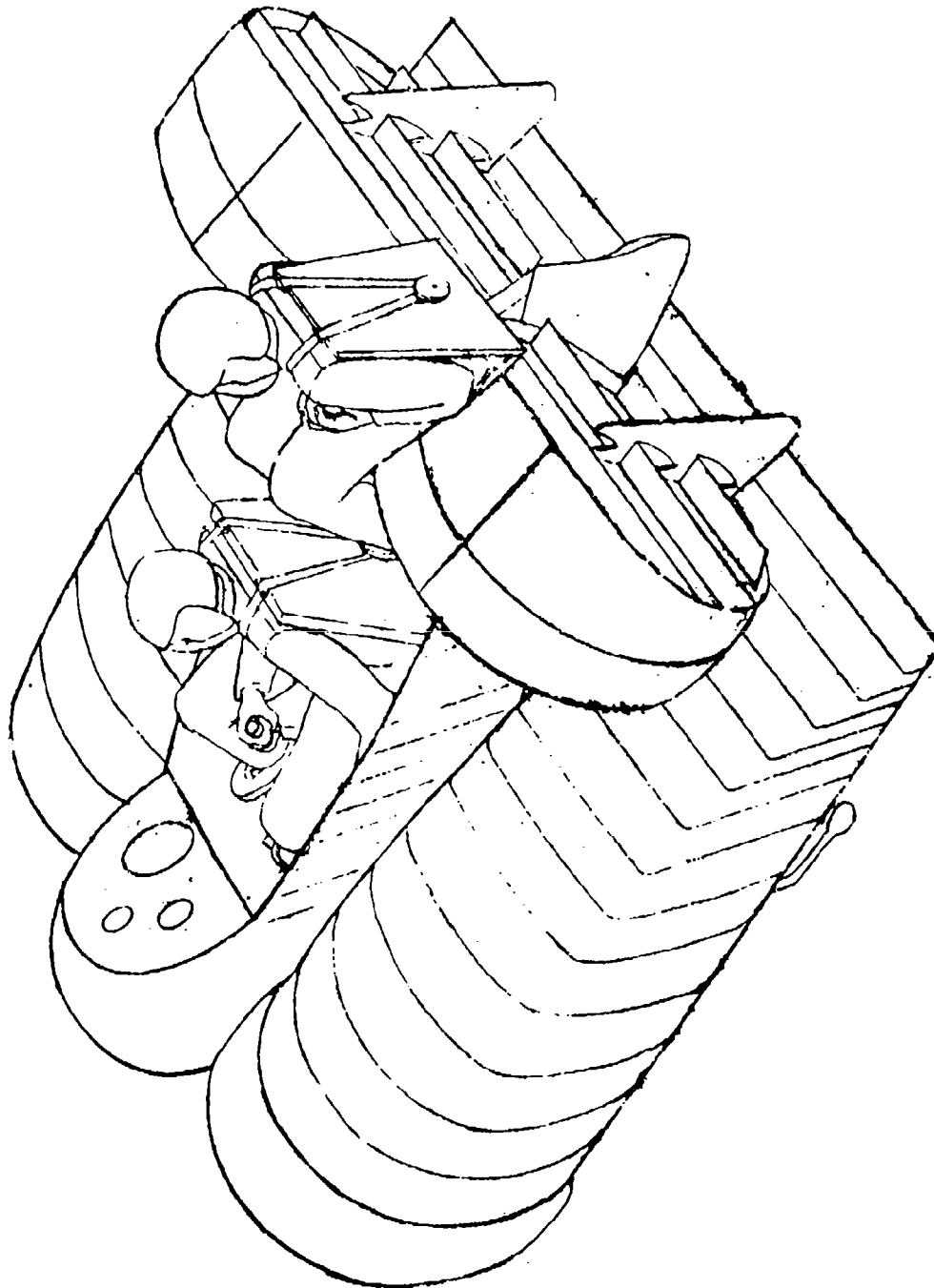

Figure 3.2.3.5.2 Piasecki Aircraft Model 159B Design,  
Top Rear View (from Reference 3.2.17)

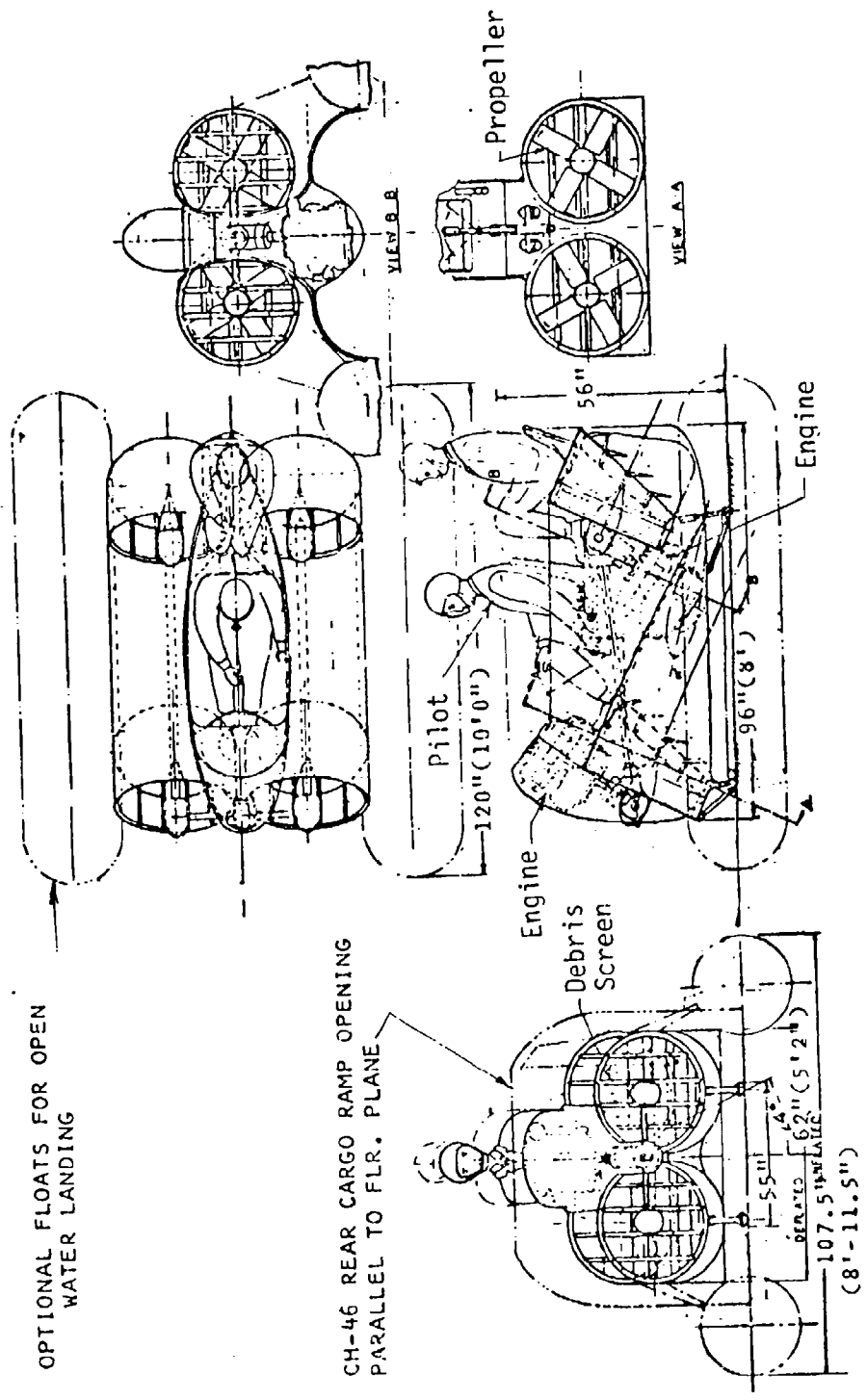

Figure 3.2.3.5.3 Piasecki Aircraft Model 159B Design with Two RC Engines - General Arrangement Drawing (from Reference 3.2.17)

Features of Design 159B: Figure 3.2.3.5.3 shows some details of this recommended vehicle. Each of the ducts contained a four-bladed propeller, multiple flow-deflecting (thrust vectoring) vanes and streamlined vertical bars ahead of the propellers to keep large debris out of the ducts. The rear ducts had rudder surfaces in the duct efflux area. Power was transmitted from the two engines via six gear boxes and shafting; the two main gear boxes, one at the front and one near the rear, were interconnected by a longitudinal drive shaft. Each of the two 250 hp RC engines fed its power into one of the gear boxes, the engines being mounted near the respective boxes. Transverse drive shafts from each main gear box supplied power to the propeller gear boxes.

The fuselage was of the open cockpit type and provided attachment for the ducts and a single skid type landing gear (Figure 3.2.3.5.1). Twin lateral legs, attached to the outer walls of the forward ducts, steadied the vehicle on the ground. For water operation, twin floats could be attached outside of and below the ducts, increasing the width of the vehicle to 9 ft from the basic value of 62 in.

Figure 3.2.3.5.4 shows the basic structural arrangement of the airframe. Extensive use was to be made of fibrous composite materials in shell structure with suitable reinforcement and stiffening (e.g. honeycomb in the duct walls). This was aimed at obtaining a lightweight, rugged structure. The underbody was to be a sealed surface to make it impervious to debris, dust, gases and other foreign materials. This was necessary because of the air pressure developed in ground effect. Openings with removable, reinforced panels were to be used to permit access to and removal of components such as engines and gear boxes.

The Model 159B was estimated to weigh 1650 lbs at take-off to meet the Marine Corps performance requirements (Table 3.2.3.5.1) operating with a 480 lb payload. Empty weight was estimated to be 906 lbs. These are compared with the acceptable and desired values in Table 3.2.3.5.2.

Flight Control: Control moments were provided in hover and low speed flight by differentially changing the propeller thrusts (blade pitches). Differential pitch change between left and right sets of propellers produced roll and differential change between fore and aft propeller sets pitched the vehicle. Yawing moments were provided by deflection of the rudder surfaces. In forward flight, the flow turning vanes were in a less deflected position and the force vector was inclined forward of the vertical causing differential propeller thrust to produce coupled lateral-directional motion. In forward flight and in hover yaw-roll coupling resulted from the use of the rudder surfaces since they were below the vehicle's c.g. Piasecki proposed to reduce both of

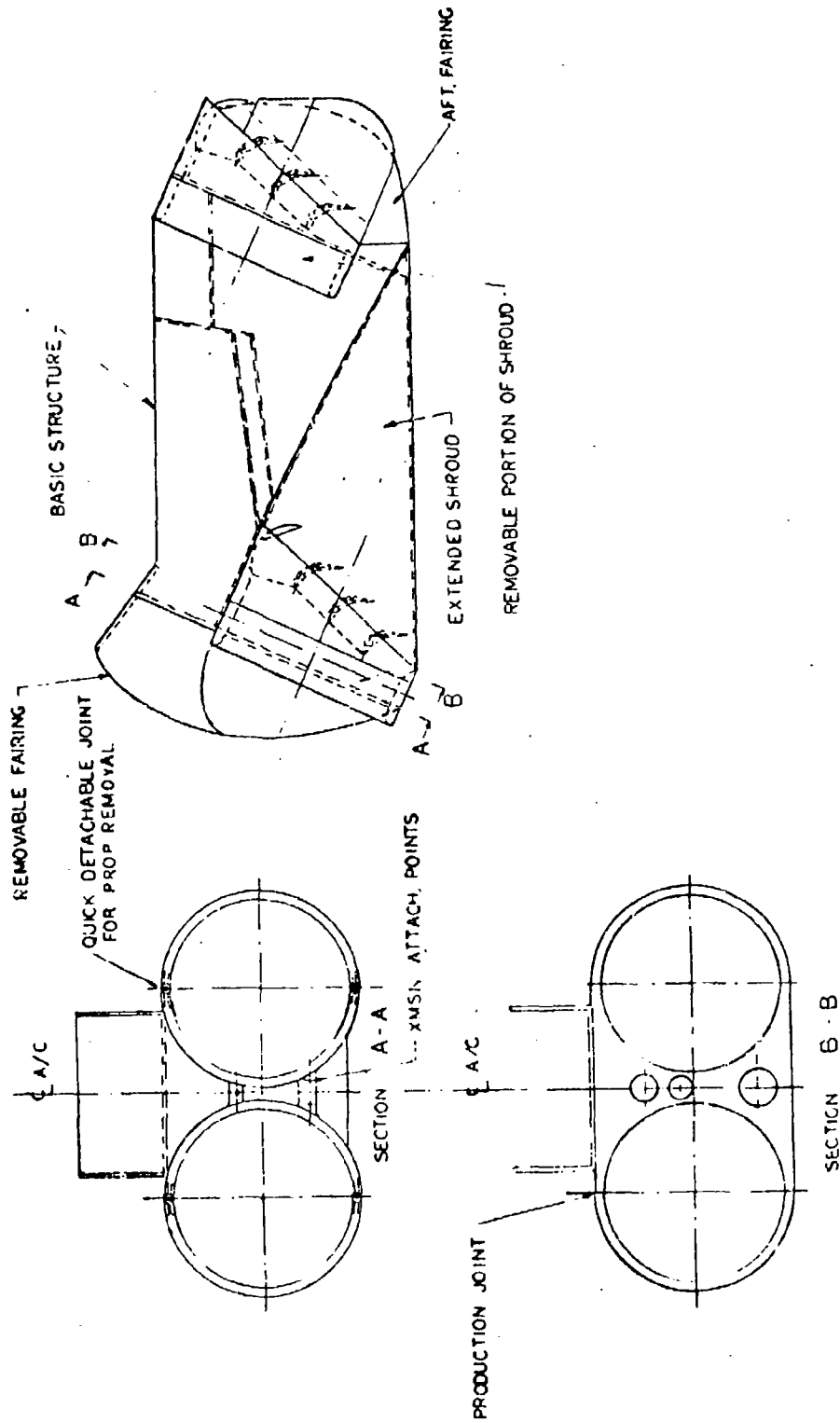

Figure 3.2.3.5.4 Piasecki Aircraft Model 159B Design - Structural Arrangement  
(from Reference 3.2.17)

TABLE 3.2.3.5.2

**WEIGHT AND PERFORMANCE SUMMARY PIASECKI MODEL 159B**  
 (Twin RC Engine Design)  
 (Standard Day, 59°F, SL)

	<u>Required Values</u>		<u>Model 159B</u>
	<u>Acceptable</u>	<u>Desirable</u>	
Gross weight, lb	NS*	NS	1650
Empty weight, lb	450 <sup>1</sup>	NS	906
Useful load	NS	NS	744
Payload, lb <sup>2</sup>	450-500	800-850	480 <sup>3</sup>
Normal fuel, lb	NS	NS	70
Hover disc loading lb/sqft	NS	NS	104
Hover power loading lb/hp	NS	NS	3.3
Vertical rate of climb, ft/min	NS	NS	750
VTO altitude (hover ceiling, O.G.E.)** ft	3000-4000	7000-8000	3000
Avg. cruise speed, mph	37-40	71-75	92 <sup>4</sup>
Max. speed, mph	NS	NS	153
Absolute (hover) endurance, min	30-35	60-65	18
Range, st. miles	16-19 <sup>5</sup>	30-53 <sup>6</sup>	180 <sup>7</sup>

\* NS - not specified

\*\* O.G.E. - out of ground effect

<sup>1</sup> To permit 3 men to lift the vehicle.

<sup>2</sup> Payload = normal fuel + 200 lb passenger + tools or special equipment.  
 (Operator is not payload.)

<sup>3</sup> For 15.5 mile range with 20% fuel reserve

<sup>4</sup> At minimum power

<sup>5</sup> With 450-500 lb payload.

<sup>6</sup> With 10% reserve fuel.

<sup>7</sup> With 200 lb payload, 20% reserve fuel.

these couplings by incorporating a mixing linkage in the cockpit controls so that lateral displacement of the stick, not only changed propeller blade pitch but, also, rudder deflection. Similarly, movement of the rudder pedals adjusted propeller blade pitch to reduce roll. Fortunately, these couplings were in the proper sense for coordinated maneuvering and any residual coupling would not feel unnatural to the pilot. Each of the control mixing ratios was to be fixed at a value which minimized coupling for the overall operating range of the vehicle.

Height control in hover and low speed flight was provided by simultaneous pitch change of all four propellers with the power changes being handled by engine governors holding the rpm at a pilot-selected value.

Piasecki Aircraft proposed that the cockpit controls used be similar to those in helicopters. Longitudinal and lateral motion of a conventional stick was to pitch and roll the vehicle and rudder pedals controlled yaw. Simultaneous change of propeller blade pitches was to be accomplished through a collective pitch stick at the operator's left hand. Engine power controls were to be located on the collective stick and the engine rpm was to be governor controlled. Deflection of the thrust vectoring vanes was to be via a "beeper" switch on the longitudinal-lateral stick. It was estimated that the control forces would be low enough to allow use of a full manual, mechanical linkage system except for the "beeper" control of the thrust vectoring vanes.

Consideration was given to an alternate control system aimed at making it easier for personnel, without helicopter pilot experience, to fly this vehicle. This control system incorporated yaw control into the conventional stick via a twist grip and collective pitch control into the left foot pedal. The operator's left hand and right foot then would be available for other chores except for the use of that hand to make occasional throttle adjustments when over-riding the governors and during engine start. Hydraulic boosters for rudder and for the collective pitch control were considered be necessary for this alternate control system.

Piasecki believed that the flight handling characteristics would be favorable because of the high control power and damping available about all axes--pitch, roll and yaw. The basis for this assessment was the high values of control power available (angular acceleration per inch of control motion) compared with the requirements of the Helicopter Flying Qualities Specification, MIL-H-8501. The high damping was due to the inherently large side forces produced by transverse motion of powered ring wings (ducts)--up to 250% greater than that of unpowered ring wings.

Good vertical acceleration of about 0.2 g per inch of collective stick motion was calculated. Despite the inherently high resistance to sideward motion, analysis showed that it was possible to hover in a 25 kt crosswind or fly sideways at this speed.

The control mixing system contributed to the expected ease of flight by providing nearly pure roll and yaw in hover/low speed flight and favorable yaw due to roll at higher forward speeds. Ease of flight was expected to reduce operator training requirements. Piasecki Aircraft did not consider the use of a stability augmentation system.

Performance of Model 159B: Table 3.2.3.5.2, based on data from Reference 3.2.16, compares the estimated performance and weights of Model 159B with the acceptable and desirable values established by the Marine Corps for the STAMP.

From the data presented in Table 3.2.3.5.2, it appears that the Piasecki Model 159B vehicle will:

1. Be too heavy (906 lbs empty wt) to be lifted by three men.
2. Be capable of carrying the acceptable payload (480 lbs) over the minimum acceptable range (16 statute miles).
3. Have a hovering ceiling of 3000 ft at design gross weight, thus meeting the minimum acceptable value on a standard day.
4. Have a cruise speed (92 mph), well in excess of even the desired 75 mph.
5. Have a top speed of 153 mph.
6. Be incapable of hovering for the minimum acceptable duration of 30 minutes. Normal fuel (70 lbs) will allow about 18 minutes of hover.
7. Be capable of 180 mile range with 280 lbs of fuel (payload reduced from 480 to 200 lbs).

Emergency Descent of Design 159B:  
Emergency descent capability was the principal reason for selection of a twin-engine configuration. While a single engine vehicle would have been able to maintain control at speeds above 100 mph, after engine failure, because of the ring

wings and control surfaces, a very hazardous landing would occur due to the combined high forward and sink speeds. With the disc loadings used (about 100 lb/sq.ft.) and resulting small duct size, complete loss of power at low speed and other than very low altitudes would result in an uncontrolled crash.

With the twin engines, loss of one engine would not result in loss of control in any flight mode. It was claimed that emergency landings could be made from a hover at 1400 lbs gross weight, within the ultimate strength of the landing gear. At design gross weight (1650 lbs) ground contact would be at about 1800 feet per minute from a hover at 45 feet and, it was believed, that a survivable landing could be made. Level forward flight could be maintained on one engine at 1300 lbs gross weight (operator + 200 lbs payload).

Transport in CH-46 Helicopter: One of the requirements was the internal transport of four STAMP vehicles in a CH-46. Only three Model 159B vehicles could be fitted into the helicopter with its cargo ramp down; this reduced to two with the ramp closed.

Downwash Effects: The disc loading of the Model 159B, at design gross weight, is 104 lbs/sq.ft. giving a downwash velocity of 209 fps (142 mph) in hover. This high velocity could be expected to produce significant erosion of some types of ground, possibly posing hazards to people and objects in the vicinity. The nature of flow however, would be such as to generate little "give-away" clouds of dust, snow, water mist (signature) when the vehicle is in motion close to the ground. At higher altitudes, but with the downwash still impinging on the ground, there would be a signature visible from a distance. However, the operator would have clear vision of the ground in the near vicinity of the vehicle. Little recirculation of contaminated air would occur during short time hover or with translation. Winds could be troublesome, bringing contaminated air to the vehicle. Temperature of the efflux would be near ambient.

#### Concluding Observations:

1. While the Piasecki design effort did indicate that it may be possible to base a small vehicle, aimed at STAMP type operations, on a lower cost power plant (RC engine) than a turbine, the resulting vehicle design selected was larger, heavier and mechanically more complex than the concept sought by the Marine Corps. Its empty weight, 900 lbs, was more than double the acceptable limit.

2. The large horsepower required for hovering, produced quite high cruise and top speed capability. Because of the propulsive ring wing lift system with its better lift-drag ratio and the favorable engine specific fuel consumption at part power, relatively good range capability would be available compared with the direct-lift wingless concepts.

3. Because of the Ring Wing's ability to produce "g" forces in forward flight greater than those of the direct-lift system, the vehicle maneuverability should be better than that of the thrust-borne type STAMP vehicles. However, it still may not be fully satisfactory in certain operations requiring good agility.

REFERENCES - SECTION 3.2

- 3.2.1 Koch, Joseph, "United States Air Force, SR 175, VTOL STOL Aircraft Survey," Report No. SER-50112, Sikorsky Aircraft Division of United Aircraft Corporation, Aug. 19, 1960.
- 3.2.2 Brochure: "Design Considerations of VTO Aircraft," Hiller Helicopters, Date - approximately 1955.
- 3.2.3 "Small Aircraft Turbofan Studies," Aviation Week and Space Technology, Feb. 9, 1970, pp. 43-48.
- 3.2.4 "Bell to Test New Flying Belt for the Military," Aviation Week and Space Technology, July 22, 1968, p. 65.
- 3.2.5 "IMS - Individual Mobility Systems," brochure from Bell Aerosystems Company, date not given (estimated date late 1967 - early 1968).
- 3.2.6 Norton, Don, "The Wingless Jet Set," article in Rendezvous, a publication of Bell Aerosystems Company, Sept. 1968.
- 3.2.7 Kowalsky, Bradley C. and Pitcher, Scott W., "STAMP - Technical Survey, Key Parameters and Technical Aspects of Promise," Technical Note 4008-6, Naval Weapons Center, Apr. 1972 (report contains proprietary information, distribution limited to DOD agencies).
- 3.2.8 Martz, James G., III and Beckett, William H., "STAMP Operational Concepts, Mission Characteristics and Design Guidelines," Technical Note TN4008-5, Naval Weapons Center, Apr. 1972.
- 3.2.9 Martz, James G. III and Beckett, William H., "STAMP Operational Concepts, Mission Characteristics and Design Guidelines," Technical Note TN4008-5, Rev. 1, Naval Weapons Center, Apr. 1973.
- 3.2.10 Wheatley, John B. and Shinn, Ronald A., "Preliminary Systems Design Engineering for a Small Tactical Aerial Reconnaissance System - Visual, STARS-V," U.S. Army Air Mobility Research and Development Labs., June 15, 1974.
- 3.2.11 "System Specification for WASP II," Specification No. 24235WR-9508, Williams Research Corp., Sept. 24, 1980.

- 3.2.12 Underwood, Maj. David L. and Nagata, John I., Preliminary Airworthiness Evaluation (PAE) Williams Aerial Systems Platform II (WASP II) Individual Lift Device (ILD), Final Report, USAAEFA Project No. 81-12, U.S. Army Aviation Engineering Flight Activity, June 1982.
- 3.2.13 "Test Report - Small Tactical Aerial Mobility Platform (STAMP) - Demonstrator Vehicle Static Tests and Tethered Tests," Report No. 74-210824, Garrett AiResearch Manufacturing Co. of Arizona, Mar. 19, 1974.
- 3.2.14 Feasibility Study for Small Tactical Aerial Mobility Platform (STAMP)," Technical Report 74-210825, Garrett AiResearch Manufacturing Co. of Arizona, Mar. 27, 1974.
- 3.2.15 Alperin, Morton; Wu, Jiunn Jeng; and Smith, Charles A., "The Alperin Jet-Diffuser Ejector (AJDE) Development, Testing, and Performance Verification Report," Report NO. NWC TP-5853, Naval Weapons Center, Feb. 1976.
- 3.2.16 Quinn, B., "Recent Development in Large Area Ratio Thrust Augmenters," AIAA/SAE Joint Propulsion Specialist Conference, New Orleans, Louisiana, 1972.
- 3.2.17 Camera, R. S.; Goldberg, J.; Kubicki, P.; Meenen, K. R.; Meyers, D. N.; and Piasecki, F.N., "Preliminary Design Study of STAMP (Small Tactical Aerial Mobility Platform) Configurations, "Final Report 159-X-36, Piasecki Aircraft Company, Nov. 30, 1973.
- 3.2.18 "Wind-Tunnel Tests of a 1/4-Scale Model PA-22 VTOL Aircraft," Report No. TED AD-3215, David Taylor Model Basin, 1958-1960.
- 3.2.19 Goldberg, J., "Tail Duct Stabilizing Moment, PiAC Model 16H-1B," Report No. 16-A-16, Piasecki Aircraft, Sept. 30, 1965.

### 3.3 TURBOJET/TURBOFAN-L/C-VERTICAL ATTITUDE TAKE-OFF AND LANDING (VATOL) AIRCRAFT

#### 3.3.1 Introduction

Initiated by the U.S. Navy in the late 1940's, the first government-funded VTOL airplane development efforts were aimed at creating "Convoy Fighters" to be operated from small platforms on ships. At that time (1944) vertical attitude appeared to be the most direct and least complex airplane approach to VTOL. While the problems of pilot seating, vision, servicing and maintenance for the VATOL types were recognized, the merits of their relative simplicity and basic configuration similarity to conventional fighters were believed to outweigh the drawbacks. Regarding horizontal attitude approaches credible solutions had not yet emerged and the use of STOL, as a means of increasing load capability, was not then an important consideration. The principal objective was to exploit VTOL capability.

Both the turboprop and turbojet approaches were of interest to the Navy. The initial developments were turbo-props, the Convair XFY-1 and Lockheed XFV-1, but interest in such propulsion for fighters already was vanishing. The Navy initiated work on the jet-propelled approach but only a small amount of funding was available for such activities, the XFV-1 and XFY-1 having absorbed most of the Navy VTOL development money. The Navy's initial jet-propelled development effort, a \$47,000 contract with Ryan in 1947, was aimed at establishing the viability of vertical flight control through thrust deflection at the tail and jet reaction at the wing tips.

Since the beginning of turbojet VATOL aircraft development in the 1940's there has been a sporadic but continuing interest in the concept, because of its advantages over the horizontal attitude VTOL types in the areas of combat, empty weight and cost. Interest waned after 1947, revived between 1951 and 1959 during the French SNECMA Coleopter development, and subsided again until the 1970's when Boeing, Northrop, Vought, NASA and the Naval Ship Research and Development Center (NSRDC) undertook research and development efforts. Principally, these focused on studies and research. During the 1970's only the NSRDC built an aircraft, the XBQM-108A, a small jet-propelled VATOL remotely piloted vehicle. It is interesting to observe that, despite the interest in VATOL aircraft, only three such machines have been built during the past 40 years; Ryan's X-13, SNECMA's Coleopter and the Navy's XBQM-108A. The lack of activity can be attributed primarily to the unusual pilot position and the unorthodox take-off and landing operation. Currently (1985), there is little VATOL aircraft effort, however interest continues to persist.

VATOL aircraft divide into two basic types, those which hang from a special vertical take-off and landing apparatus and those which sit on the ground. The hanging type permits achievement of the simplest, lightest aircraft because it requires only a minimal device, such as a hook, to operate from ground (or ship) apparatus. The X-13 (Figure 3.3.2.14) is a good example of this concept. Such an aircraft is entirely dependent on ground apparatus, not only for take-off and landing but also for being placed in a horizontal position for servicing, maintenance and for transport from area to area. The apparatus can be readily provided with a means for deflecting the airplane's jet blast to reduce ground impingement and recirculation effects.

The VTOL apparatus can take various forms ranging from those which are anchored to the ground and immobile (Figure 3.2.5.2.10) to those which permit overland transport (Figures 3.3.2.14 and 3.3.2.15). When used with an anchored apparatus a means for moving the aircraft to and from the apparatus is necessary. The "U"-shaped wheeled rig shown in Figure 3.3.1.1 is such a device. Figure 3.3.1.2 shows the VTOL apparatus proposed by Boeing for shipboard use with their proposed VATOL Sea Control Fighter. This system was designed to move the airplane between its VTOL position and the ship's hold.

Various capture systems can be used. Figures 3.3.2.14 and 3.3.5.2.10 show a cable for engaging a hook on the airplane. Vought's airplane in Figure 3.3.1.3 uses a prong which penetrates a wire mesh platform.

As shown in Figures 3.3.1.3 and 3.3.5.2.1 the hanging type VATOL airplane can be equipped with a conventional landing gear in addition to the device which permits it to hang on the VTOL apparatus. While the landing gear gives the airplane ground mobility and the capability to make running take-offs and landings, it causes the airplane's weight and size to be substantially greater than that of a pure hanging VATOL type of equal mission capability, both operating VTOL. This increase is well beyond the weight of the landing gear itself because of growth factor, the pyramiding effect of the landing gear on engine and airframe size, fuel, etc.

VATOL aircraft which sit on the ground (tail-sitters) will be heavier than the pure hanging types for equivalent mission capability but do not require any special take-off or landing ground apparatus. However, another type of ground apparatus still is required for rotating the airplane between vertical and horizontal positions and for providing ground transport. Figure 3.3.1.4 is representative of such an apparatus. When the tail-sitter airplane is equipped with wheels, as shown on the coleopter in Figure 3.3.3.3, it can be moved by itself over the ground while in vertical attitude.

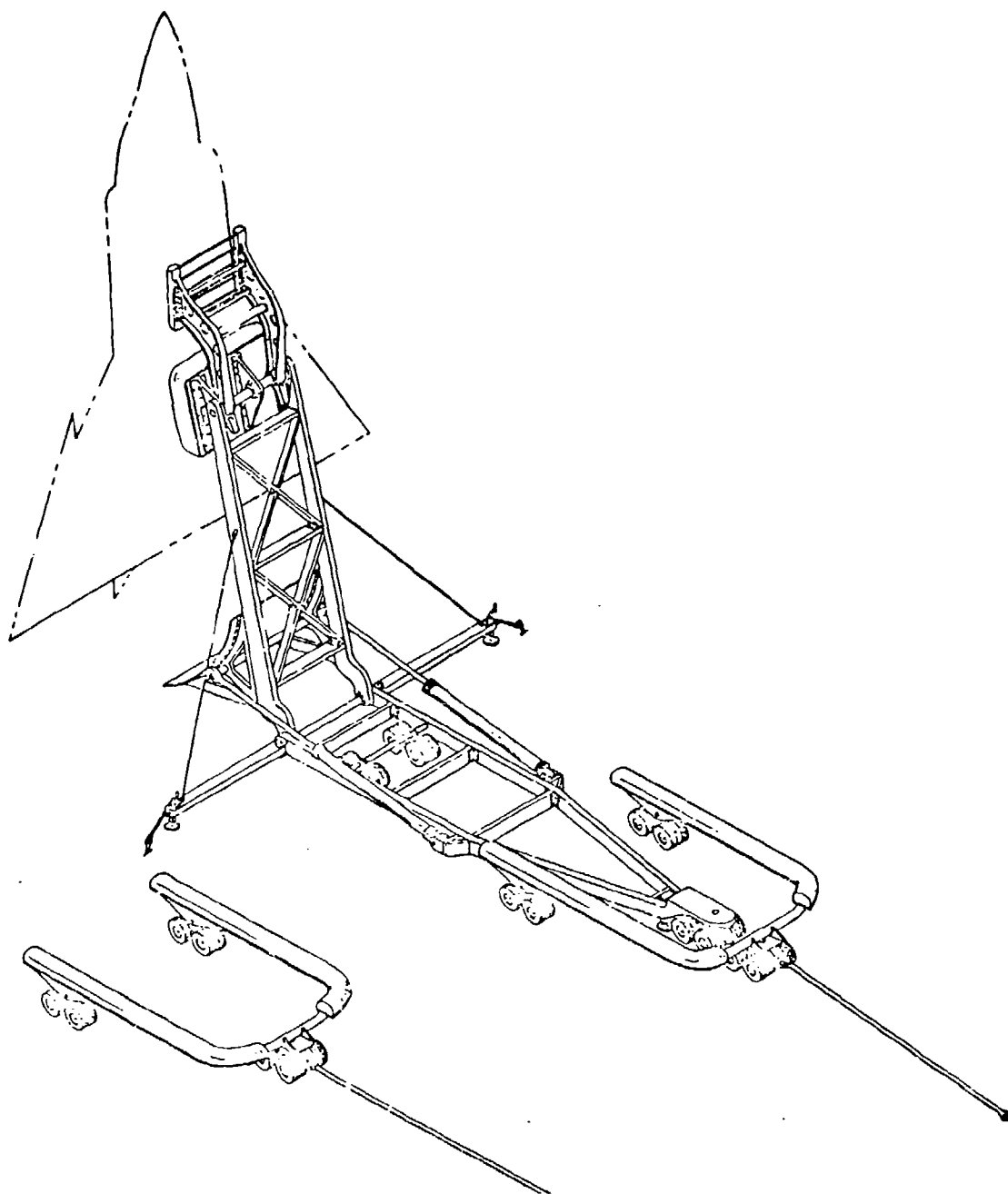

Figure 3.3.1.1 Ryan Aeronautical Vertical Take-Off and Landing Apparatus (Courtesy Teledyne Ryan Aeronautical)

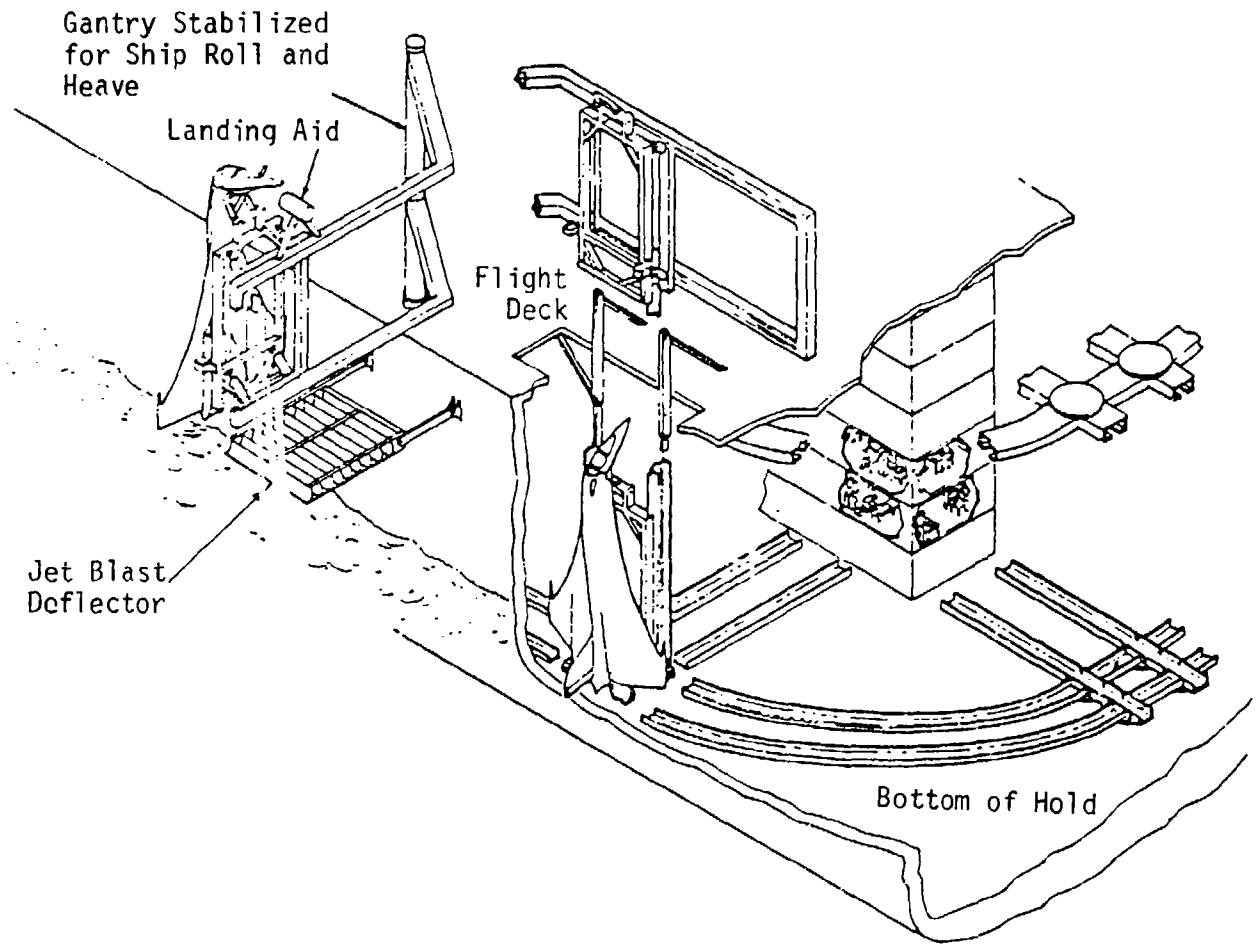

Figure 3.3.1.2 Boeing Sea Control Fighter Shipboard Handling (Courtesy The Boeing Company)

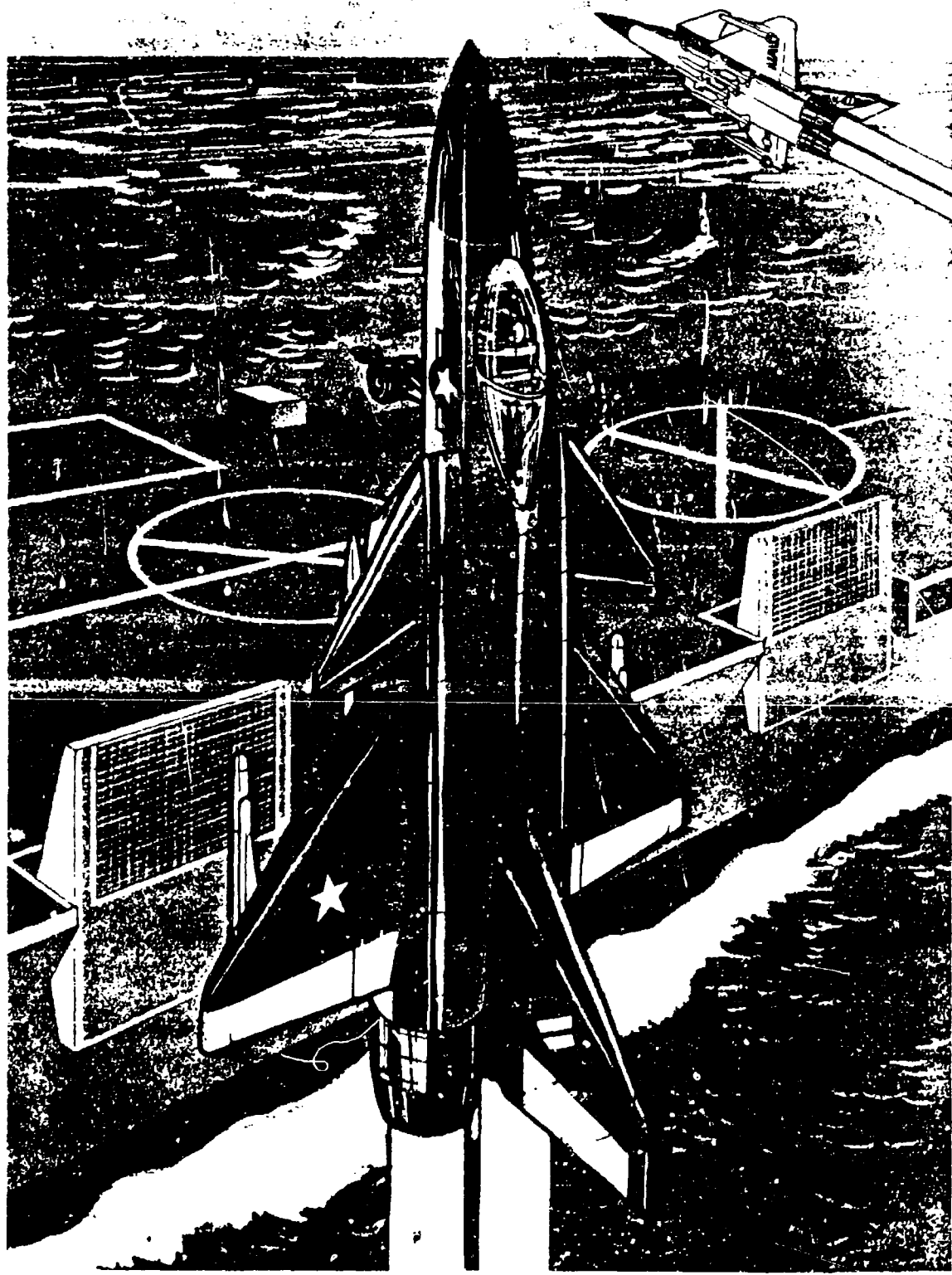

Figure 3.3.1.3 Vought V/STOL Airplane with Tricycle Landing Gear and Prong for Platform Engagement (Courtesy Vought Aero Products)

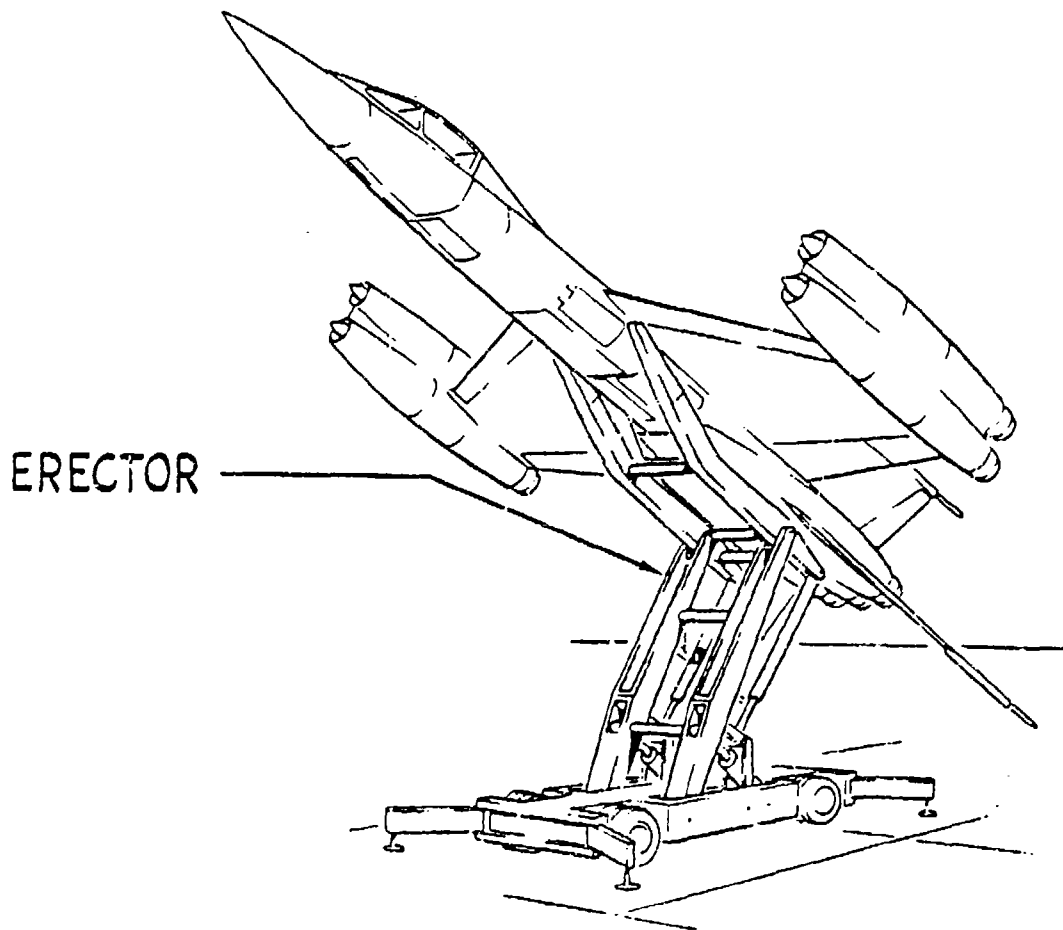

Figure 3.3.1.4 North American Aviation Erecting System  
for Tail Sitter Airplane, 1956  
(Courtesy Rockwell International)

The Figure 3.3.3.24 shows the elaborate ground apparatus devised by SNECMA for transporting and erecting the coleopter.

All ground apparatus can be eliminated by incorporating a self-erecting (kneeling) system into the aircraft itself (at the cost of increased airplane weight and complexity). Figure 3.3.1.5 illustrates the interesting arrangement proposed by Focke-Wulf which not only rotated the airplane between horizontal and vertical positions but provided ground mobility via the use of caterpillar-type tracks. In this system the major landing loads were to be taken by a central retractable strut which could be extended aftward from the fuselage. The erecting gear folded compactly into twin, small cross-sectional area, slender nacelles.

In VATOL aircraft pilot position during take-off and landing has been of much concern and a number of solutions are possible. These range from the use of prone position (as shown simplistically in Figure 3.3.1.6) through tilting of the seat as in the X-13 (Figures 3.3.2.10 and 3.3.2.12), "articulation" of the cockpit (Figure 3.3.1.7), and tilting of the entire nose containing the cockpit (Figure 3.3.1.8). The tilting nose permits the pilot to maintain a conventional seated position during VTOL and transition. The tilting nose and, to a lesser extent, the articulating cockpit give the pilot good vision during VTOL but with the tilting seat, as in the X-13 (Figure 3.3.2.10), forward vision is highly restricted or non-existent. This was not found to be a problem in the X-13; approach to the landing platform was made in a side-slip with airplane rotation for hook-on being made a short distance from the platform. Several solutions to the forward vision problem are available for the tilting seat approach. Transparent areas can be incorporated in the cockpit floor (Coleopter Figure 3.3.3.25d) or electro-optical devices (TV cameras and screens) can be used. These permit the pilot to actually "look" through the floor.

Regarding pilot comfort, the 45° tilting seat in the X-13 was found to be quite acceptable for the short periods of vertical flight which would be used in fighter type operations. Invariably, the seated position has been preferred over the prone position principally because of the latter's reduced comfort and vision in conventional mode flight.

A major factor contributing to the relative simplicity of the VATOL airplane compared with the horizontal attitude types is the ease with which control (non-aerodynamic) can be obtained in vertical and transition flight. Conventional installation of the engines in the fuselage permits their exhausts to be deflected at the tail for thrust vector control. The forces are large and moment arms long making only small deflections necessary; little loss in lifting capability occurs when producing required control moments. The thrust deflection is used for pitch and yaw control and, with multiple

Engines 2P&W JTF 10  
Span 6,48m  
Length 10,8m  
Take-off wt 7,46t  
Empty wt 4,61t

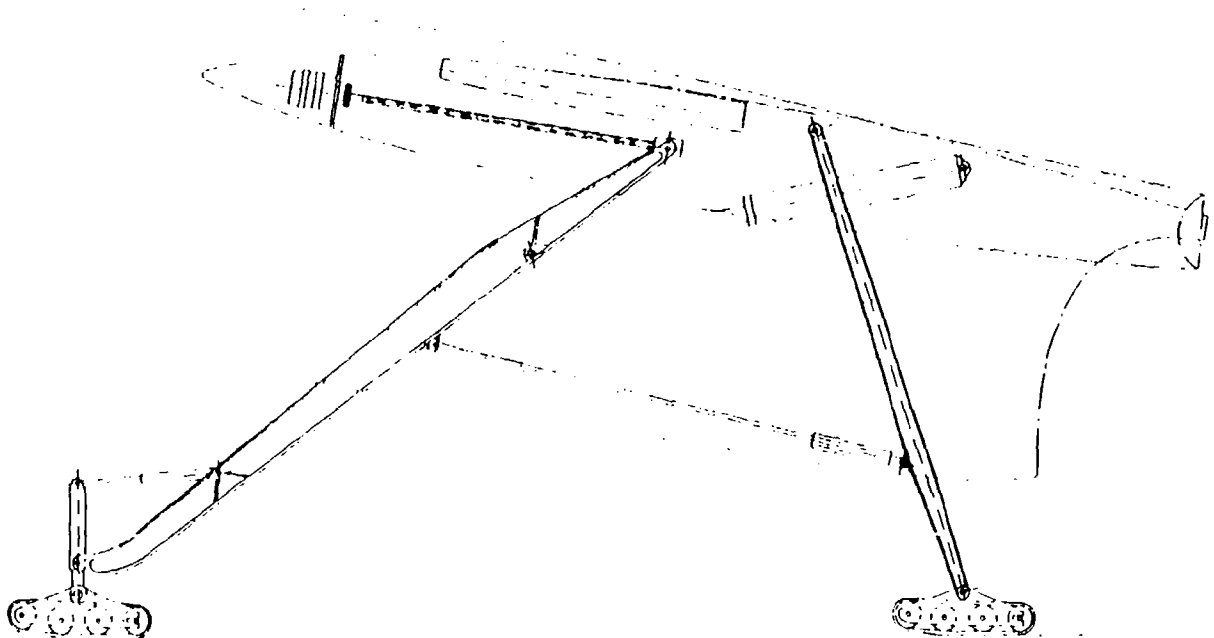
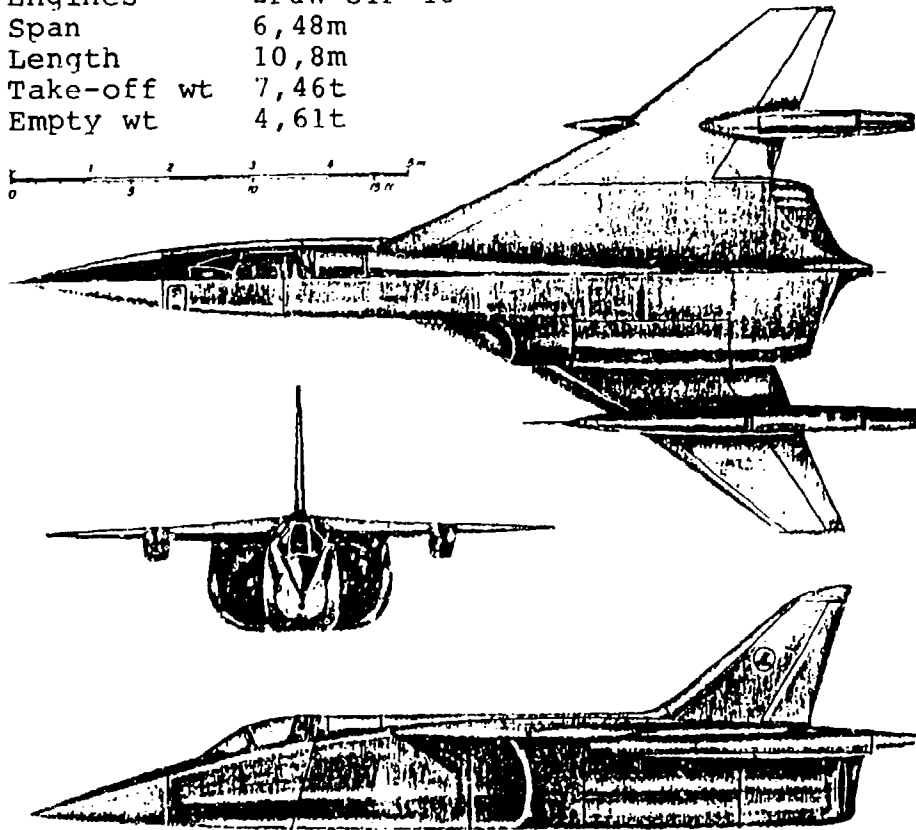
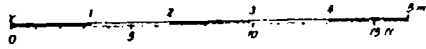

Horizontal Position

Figure 3.3.1.5 Focke-Wulf FW860 Self-Erecting  
VATOL Light Recce-Fighter (Courtesy  
Vereinigte Flugtechnische Werke)

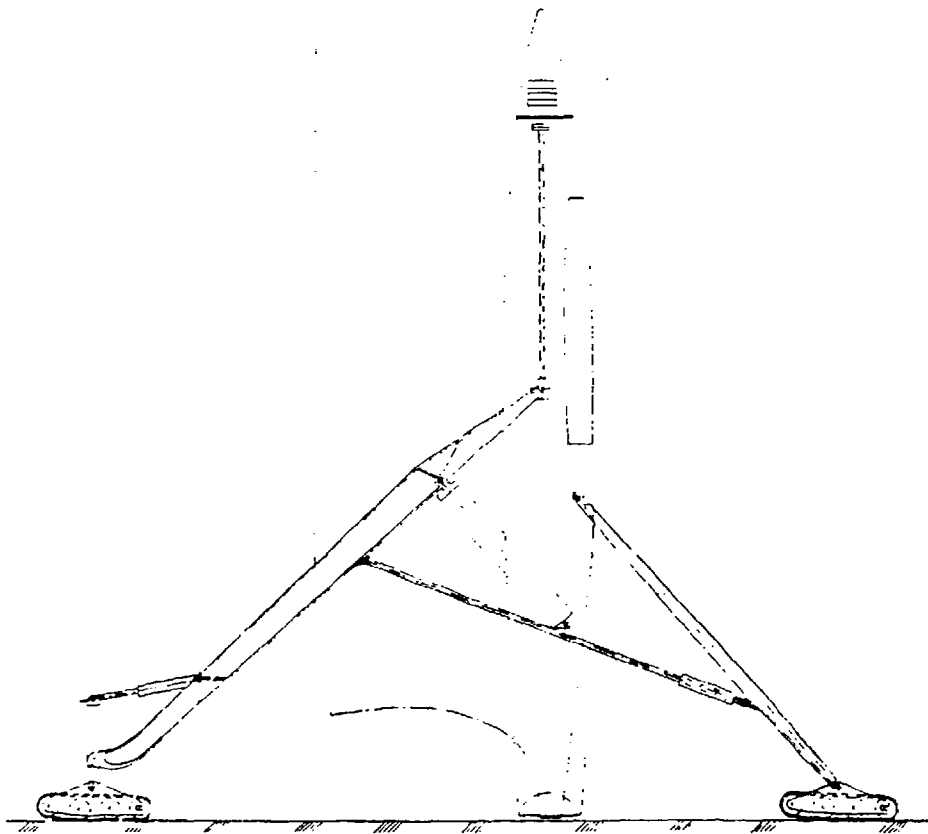

VATOL Position

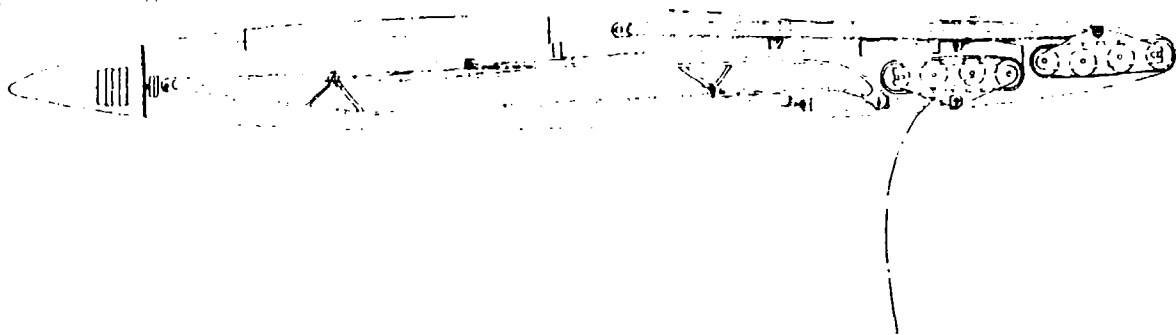

Undercarriage Retracted and Stowed in Wing Nacelle

Figure 3.3.1.5 (Continued)

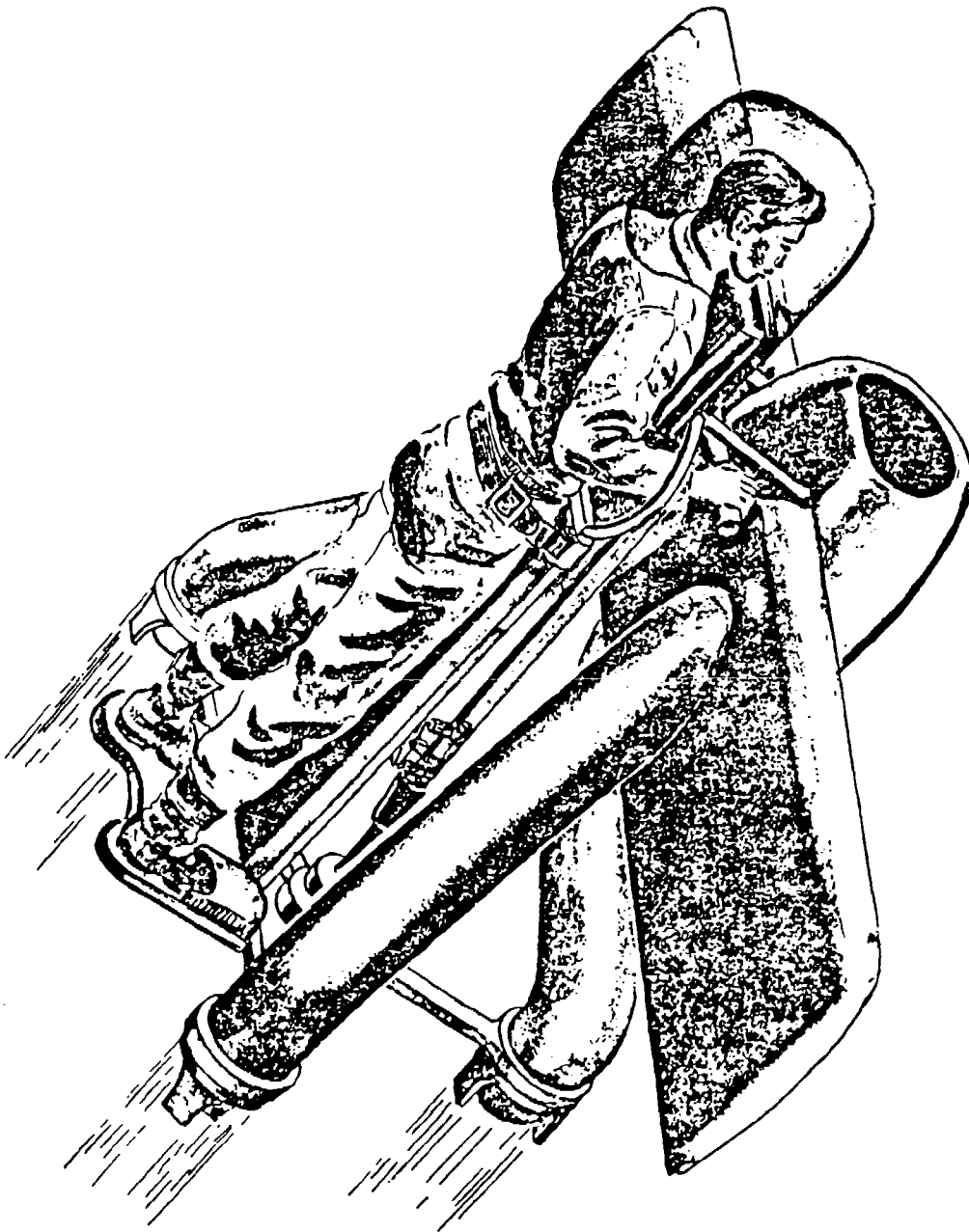

Figure 3.3.1.6 Hiller Helicopters Single Place  
Tail Sitter Concept, 1950  
(Courtesy Hiller Helicopters)

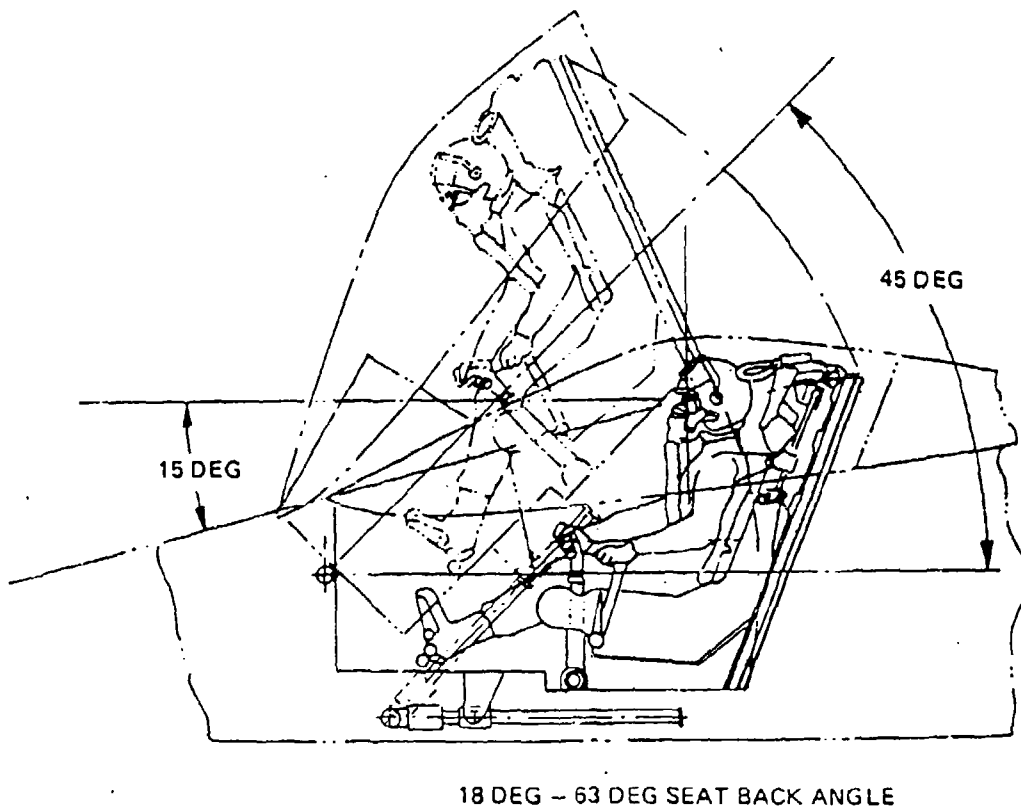

Figure 3.3.1.7 Northrop Articulating Cockpit  
for Design N336-12 (Courtesy  
Northrop Corp)

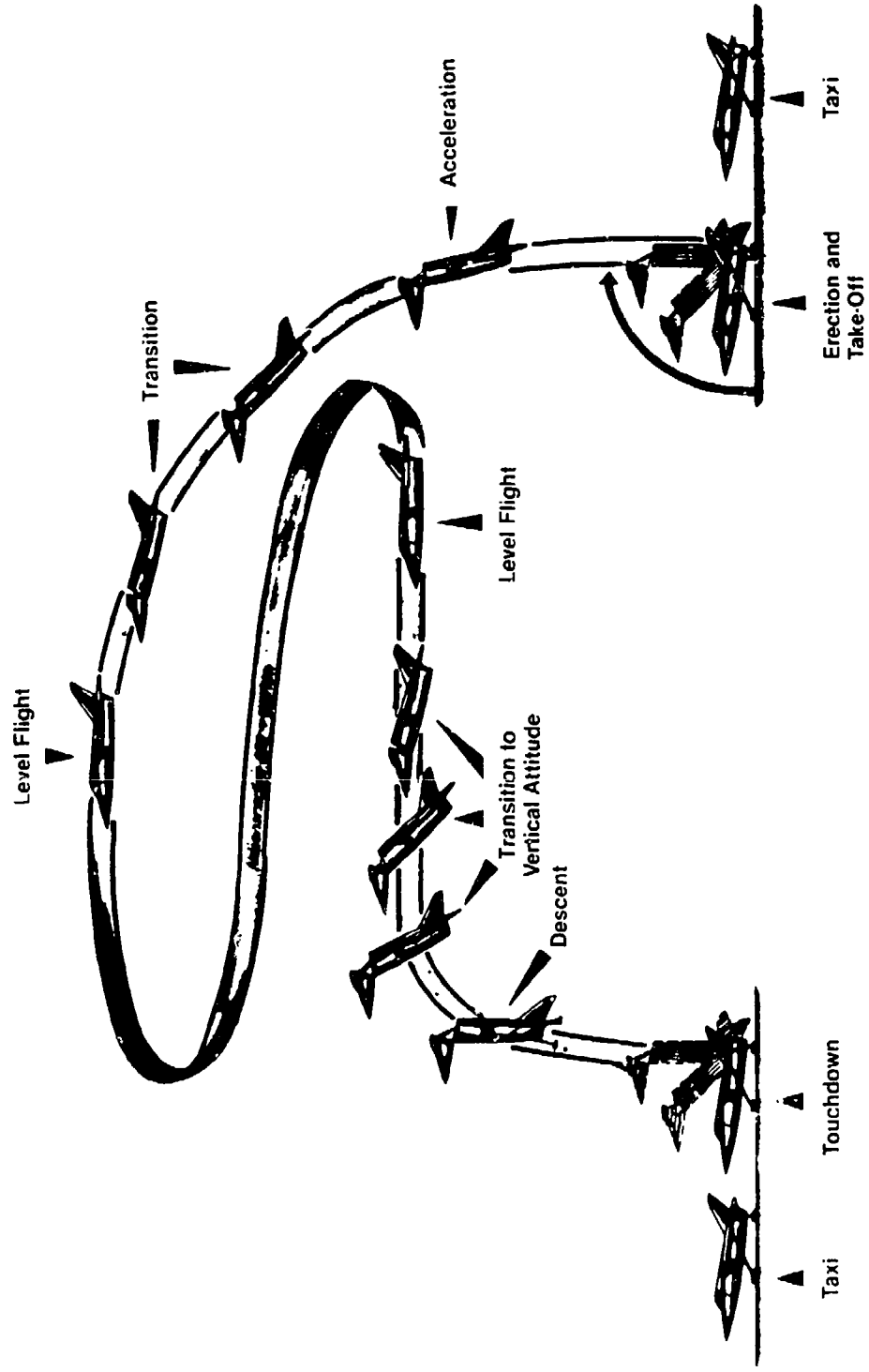

Figure 3.3.1.1.8 Focke-Wulf FW860 Self-Erecting VATOL Operation

engines, differential thrust deflection can be used for roll control. Roll control also can be obtained by reaction jets at the wing tips using engine compressor bleed air; this is most often used in single engine VATOL types. Height control is obtained by modulating engine thrust.

A particular concern with multiple engine VATOL aircraft, as with the HATOL types, is control after an engine failure. Recent VATOL designs have incorporated features which permit control to continue, albeit at reduced strength, after such a failure.

One of the most important factors affecting the design weight of the aircraft is the engine thrust/weight ratio. Because the smaller engines, such as the G.E. J-85, have characteristically had higher T/W than the larger engines, both HATOL and VATOL airplane designs have been proposed using a large number of engines. Figure 3.3.1.9 depicts a North American Aviation tail-sitter, with nine engines, two of which are fold-out lift engine types. The design shows a tilting nose in addition. This and the fold-out engines were innovative ideas in 1956.

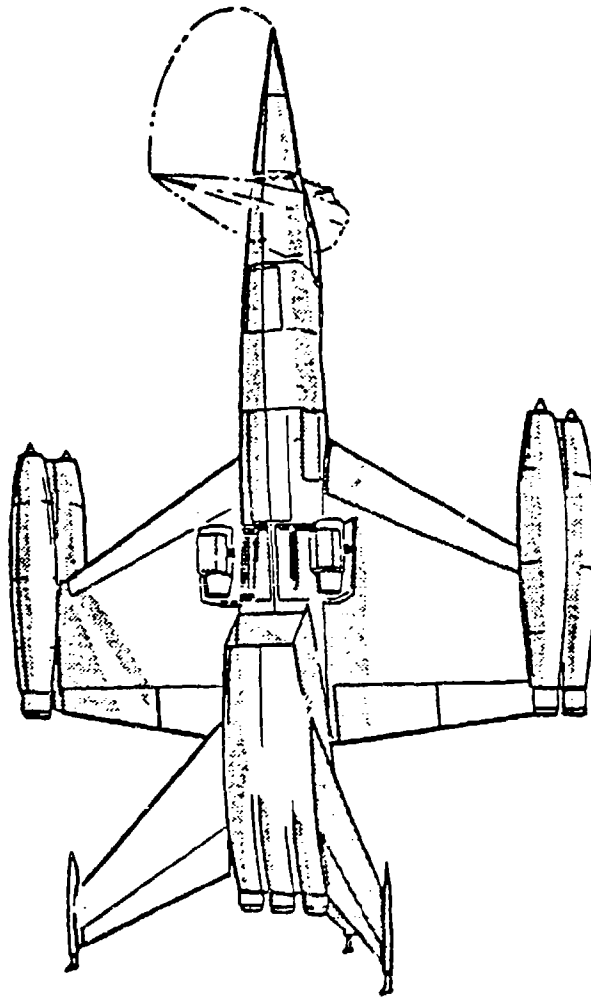

Figure 3.3.1.9 North American Aviation VATOL (Tail Sitter)  
Concept with Tilting Nose and Fold-Out Lift  
Engines, 1956 (Courtesy Rockwell International)

3.3.2 Ryan Aeronautical Company X-13 (Model 69,  
"Vertijet") (1947-1957)

From 1947 through 1957, the U.S. Navy and, subsequently, the U.S. Air Force funded the development and flight demonstration of the X-13 VATOL turbojet airplane (Figure 3.3.2.1) with the Ryan Aeronautical Company. The major events in this effort are listed in Table 3.3.2.1 below. Approximately \$8.5 million was directly invested in this program by the U.S. Department of Defense.

TABLE 3.3.2.1  
RYAN X-13 CHRONOLOGY

<u>1945</u>	VATOL Turbojet Concept conceived by Ryan Aeronautical
<u>1947</u>	Ryan awarded Navy contract to explore the feasibility of reaction control for jet VTOL aircraft, Contract No. a(s)8890 for \$47,170 (Apr.)
<u>1948</u>	Navy contract extended, Contract No. a(s)-10035 for \$202,830 added (Sept. 20)
<u>1950</u>	First restrained hover of test bed, remotely controlled (Oct. 20)
<u>1951</u>	First free hover of flight control demonstrator test bed, remotely controlled (May 31)
<u>1953</u>	Ryan submits proposal to Air Force for development and testing of VATOL research aircraft (May 7)  Air Force Contract No. AF33(600)-25895, \$7.0 million, awarded for construction and flight testing of two jet VATOL research aircraft, later designated X-13 (Aug. 15)  First pilot-on-board flight of hover test bed (first known controlled flight of a jet VTOL device with pilot on board) (Nov. 24)
<u>1954</u>	X-13 fabrication started (Jan. 20)
<u>1955</u>	First X-13 delivered to AFFTC, Edwards AFB (Aug. 16), taxi tests started Aug. 23  First CTOL flight (Dec. 10)
<u>1956</u>	First hover, temporary "Pogo" type undercarriage used for operation from ground (May 28)  Navy contract terminated (June)  First full conversion, starting and finishing in conventional flight mode (CTOL) (Nov. 28)
<u>1957</u>	First complete sequence flight--operation from cable on ground service trailer, VTO, transition to conventional high speed flight, transition to vertical flight and hook on to cable (Apr. 11)
<u>1958</u>	X-13 (No. 41620) shipped by boat from San Diego, CA to Andrews AFB, Maryland  Twelve check-out flights, both CTOL and VATOL at Andrews AFB  VATOL demonstration-AFA air show, Andrews AFB  First VATOL cross country flight from Andrews AFB to River Entrance of Pentagon. Take-off from one trailer and landing on other trailer.  X-13 VATOL demonstration from Pentagon on to course of Wright Brother's airplane demonstration (Ft. Myers - 1908) back to Pentagon landing (Jul. 29-30)  Contract completed and terminated

NOTE: All of the VATOL flights were made by Ryan Aeronautical Chief Engineering Test Pilot, Peter Girard. Lou Everett, Ryan pilot flew 3 or 4 conventional and 2 or 3 Pogo flights; Capt. Virgil Givens, USAF, flew one CTOL flight.

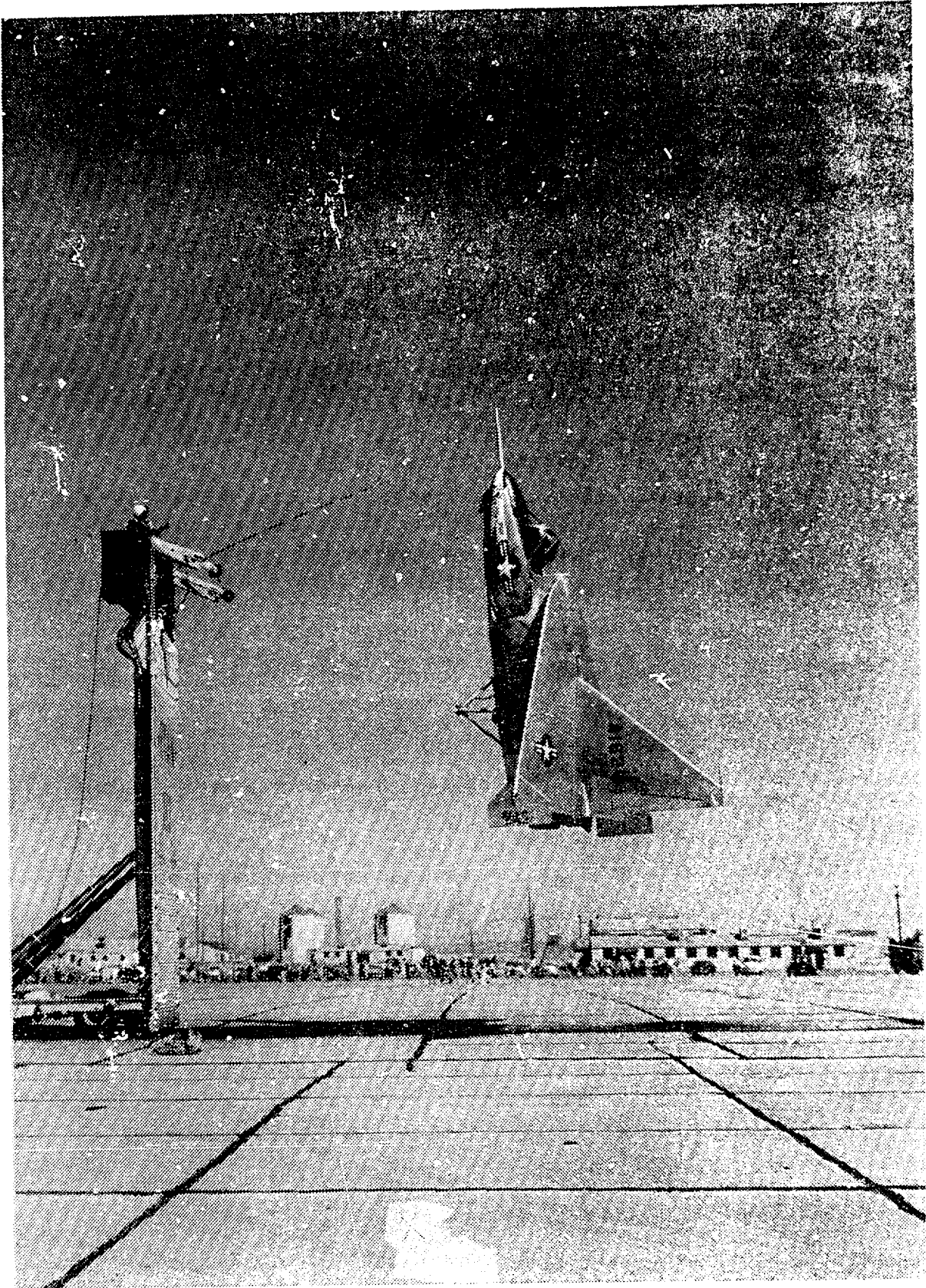

Figure 3.3.2.1 Ryan Aeronautical Company X-13 Approaching Landing Platform at Edwards AFB, 1957  
(Courtesy Teledyne Ryan Aeronautical)

As far as is known the turbojet/turbofan VATOL airplane concept first originated at the Ryan Aeronautical Company. This took place in 1945 and led to company-funded design studies. Navy interest in the potential of jet propelled VTOL fighters resulted in a \$47,170 contract with Ryan in 1947 to explore the feasibility of reaction controls for jet propelled VTOL aircraft. Subsequently this initial effort was extended and between 1947 and 1956, a number of control concepts were designed and tested statically using an Allison J-33 engine, establishing the feasibility of obtaining adequate control forces and moments to fly an airplane vertically by vectoring the engine efflux, including A/B flow, and ducting bleed air to remotely located wing-tip nozzles.

On September 20, 1948, the Navy contracted for an extension of the work, with an additional \$202,830, to permit the building and testing of a VTOL test bed (Figure 3.3.2.2) using the Allison J-33 engine equipped with an attitude stabilization system and a gimballed nozzle for pitch and yaw control and laterally displaced bleed air reaction jets (for wing tip installation) for roll. The first restrained hover of this flight control demonstrator took place on October 20, 1950 and first free hover was achieved on May 31, 1951, both using a remote control system. Subsequent improvements in the flight control and stabilization systems on the test rig, along with installation of an open cockpit, with upright seat and on-board pilot controls, permitted direct piloted vertical flight. The first such flight took place on November 24, 1953. Historically, this was the first fully-controllable VTOL machine, other than the helicopter, to fly with a pilot aboard. Later, a tilted seat (approximately 45°) and delta-shaped wing were added to make the rig more representative of the actual X-13 aircraft. Figure 3.3.2.3 shows this later version in hovering flight.

Since additional funding from the Navy was not available, the Air Force, which had been following this development with interest, accepted Ryan Aeronautical's proposal to continue the development of the concept. On August 15, 1953, a \$7 million contract (No. AF33(600)-25895) was let for the building and testing of two Ryan Model 69, "Vertijet" airplanes, later given the military designation X-13. The contract was for the design, fabrication and testing of two VTOL research airplanes to demonstrate:

1. Vertical takeoff
2. Hovering in the vertical attitude
3. Vertical landing
4. Flight in the regime between normal horizontal and hovering flight in the near vertical attitude (transition flight).
5. The ability to perform as a conventional type airplane in normal horizontal flight.

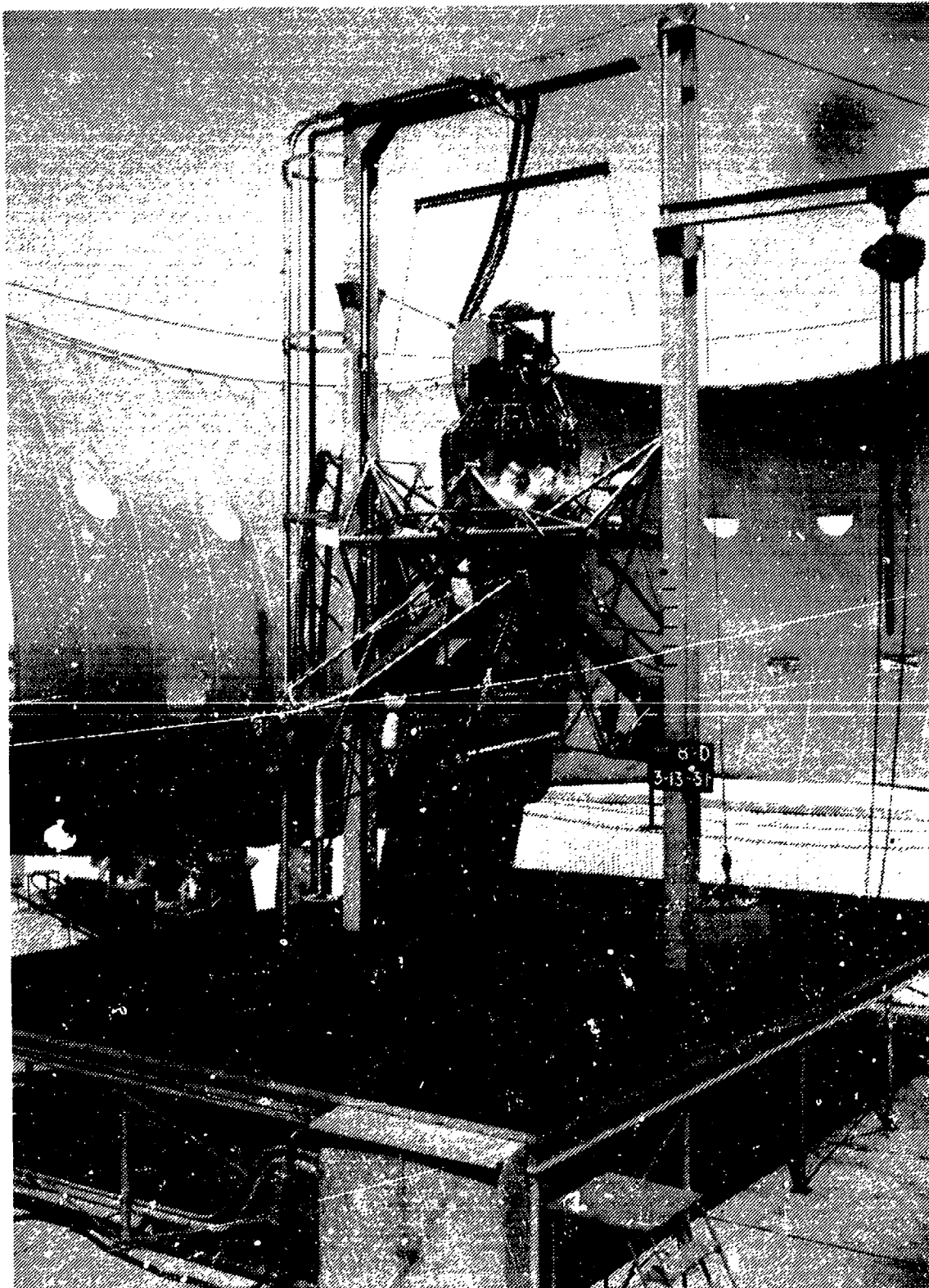

Figure 3.3.2.2 Ryan Test Bed for Exploring Vertical Flight Control-Gimbaled Nozzle and Wing Tip Reaction Jets (Courtesy Teledyne Ryan Aeronautical)

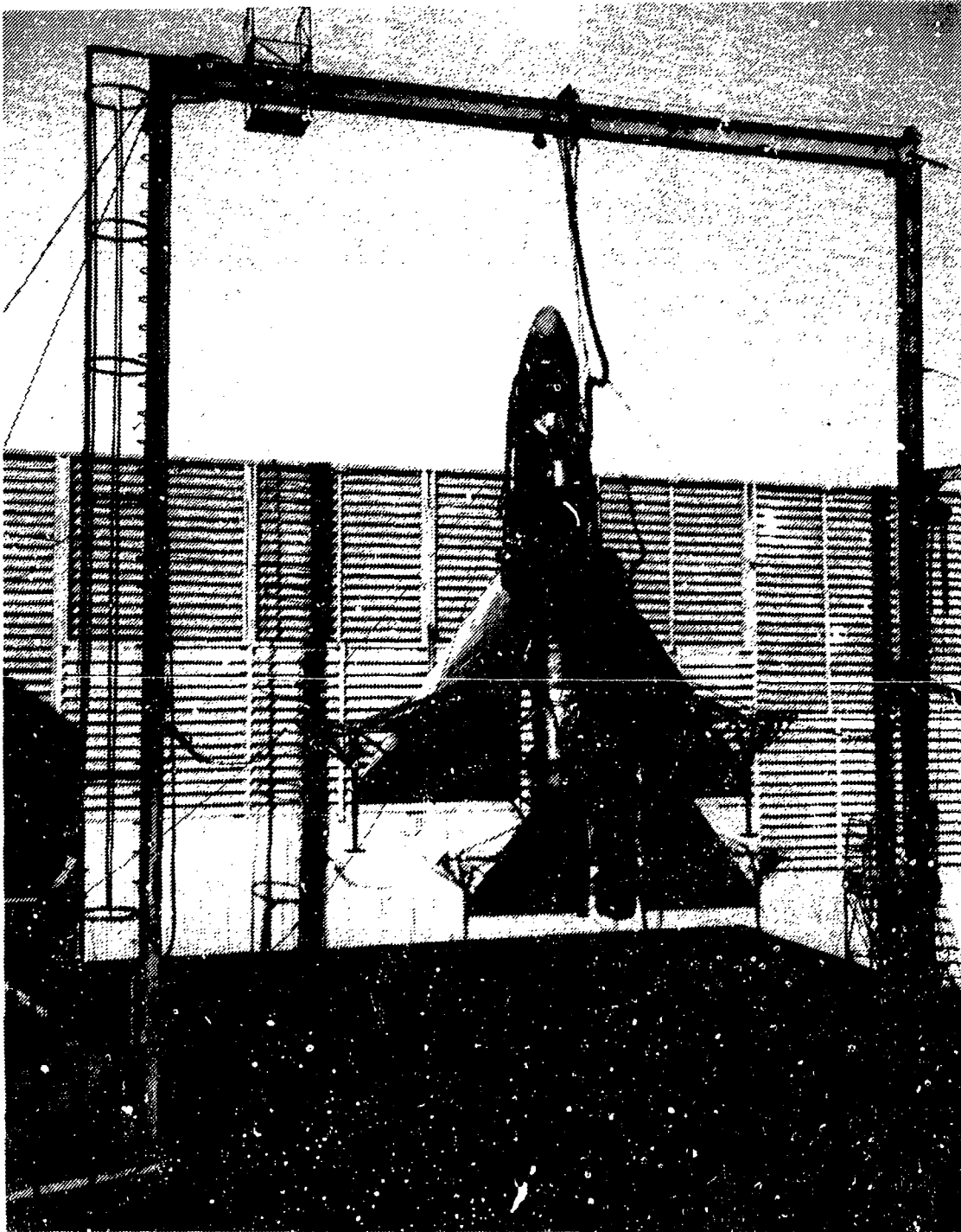

Figure 3.3.2.3 Ryan VTOI Test Bed with Cockpit, "Wings"  
and Pilot in Hovering Flight  
(Courtesy: Teledyne Ryan Aeronautical)

Figure 3.3.2.4 diagrams the required flight capabilities and, incidentally, shows two possible types of takeoff and landing apparatus examined by Ryan Aeronautical, a simple ground anchored post and wire system and a mobile, wheeled rig. The actual mobile ground apparatus used with the X-13, as seen in Figure 3.3.2.1 and other figures, was more elaborate.

Since this was to be a proof-of-concept effort the design was based on a simplified aerodynamic configuration, with little emphasis being placed on the attainment of minimum drag characteristics; the maximum design flight speed was to be 320 kts. However, to avoid lengthy vibration and flutter testing, the speed was restricted initially to about 220 kts. This was raised to 300 kts after a flutter-free test flight was made at 350 kts. The delta wing planform was chosen because of its high stall angle capability, favorable transition characteristics and applicability to a supersonic fighter configuration. Further, the airplane was designed to be of relatively low weight to permit use of an existing non-afterburning turbojet engine; and in the interest of low weight, the hook and cable VTOL system was selected over a "Pogo" type tail sitter undercarriage approach such as used by the Convair XFY-1. However, to implement the flight research plan of this unproven VATOL concept, the aircraft was built with provisions for attaching a removable, conventional tri-cycle landing gear to allow initial flight testing in the CTOL mode.

Because no fully proven non-afterburning U.S. engine was available with the necessary thrust-to-weight the English Rolls Royce RA28-49 Avon was selected, an engine with a relatively high thrust-to-weight ratio (2.6) for that time period.

Fabrication of the X-13 began on January 20, 1954 and the first airplane, equipped with a conventional landing gear (Figure 3.3.2.5), was delivered to Edwards AFB on August 16, 1955. After extensive taxi tests and lift-offs in conventional mode, during which unsatisfactory flight behavior was experienced in the form of pitching and lateral-directional oscillations, roll dampers were added. Contributing heavily to the problem were the large vertical tail and high, engine-created gyroscopics. The roll dampers improved flight characteristics sufficiently to permit the first flight, in CTOL mode, to be made on December 10, 1955. Longitudinal-lateral-directional dynamic characteristics were marginal and yaw dampers were added. The combination of yaw and roll dampers produced reasonable airplane flight behavior.

For the VTOL tests, the conventional landing gear was removed and the X-13 was temporarily fitted with a "Pogo" type tail-sitter undercarriage (Figure 3.3.2.6). It was necessary to remove the aerodynamic control surfaces to provide clearance for the "Pogo" undercarriage. On May 28, 1956, the first VTOL/hovering flight occurred during which the airplane

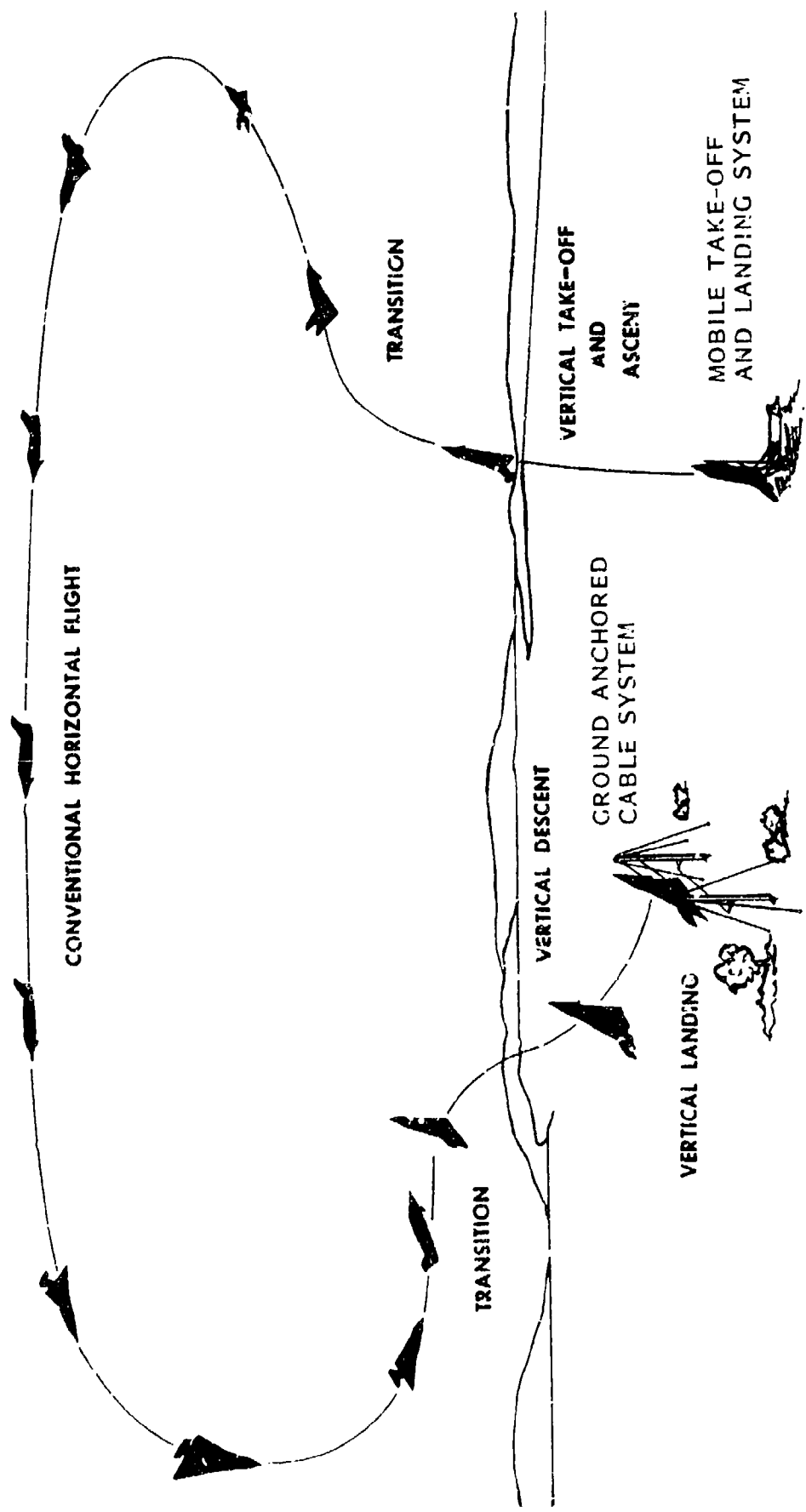

Figure 3.3.2.4 Capability Required of Ryan X-13 VATOL Airplane  
(Courtesy Teledyne Ryan Aeronautical)



Figure 3.3.2.5 Ryan X-13 with Conventional Landing Gear  
(Courtesy Teledyne Ryan Aeronautical)



Figure 3.3.2.6 Ryan X-13 In Flight with VTOL "Pogo"  
Type Undercarriage (Courtesy Teledyne  
Ryan Aeronautical)

was found to be stable and have very accurate height control. In this "Pogo" configuration the flight techniques for hooking on to and departing from the horizontal cable were perfected using a plywood mock-up of the "chin" hook and a light horizontal line strung between two vertical masts.

The first full conversion was made on November 28, 1956 using the tricycle landing gear-equipped X-13. In this operation, the airplane took off and landed conventionally. Hovering and approach to the platform were performed without actual hook-on to the cable. While not part of the X-13 design concept, use of a conventional landing gear combined with hook-on features for use on a tilting platform was obvious. This would give the airplane the capability of alternatively operating in vertical attitude or conventional take-off and landing modes.

On April 11, 1957, the airplane, equipped with the actual chin hook and with landing gear removed, successfully completed its first operation from the flatbed trailer cable going from vertical to horizontal high speed flight and returning to the cable. Before their retirement the two X-13's completed, without accident, more than 136 flights totalling over 80 hours. One hundred and four of these involved VTOL flights and were made during tests in three operational modes: "Pogo" undercarriage, CTOL and flatbed trailer. Flight demonstrations were performed adjacent to the Pentagon Building, in Washington, D.C. on July 29 and 30, 1958 following vertical take-off and flight from Andrews AFB, Maryland. One of the X-13's is now in the Air Force Museum, Dayton, Ohio; the other is in the San Diego, California Aerospace Museum (on loan from the National Air and Space Museum).

Without question, the X-13 program was outstandingly successful in establishing the validity of the turbojet/turbofan VATOL airplane concept. Despite this, and the several design studies completed by Ryan Aeronautical on derivative VATOL supersonic fighters (covered in Section 3.3.5), no further activity was undertaken in the U.S. until the 1970's. VTOL interest had shifted completely to horizontal attitude approaches.

Description of the Aircraft: The X-13 was a compact, single-place, research airplane which operated at 7,350 lb weight in VTOL with flight test instrumentation installed. Figure 3.3.2.7 shows the general arrangement and Figure 3.3.2.8 is a cutaway perspective drawing of the airplane. An inboard profile is provided in Figure 3.3.2.9. Wing span was 20.3 ft, length 23.4 and height 15.2 (based on the tricycle landing gear configuration, measured from the ground). Characteristic of the design was a modified delta wing (with rounded apex) and large dorsal vertical tail.

The delta wing configuration with 60° leading edge sweep was chosen to facilitate transition by providing high

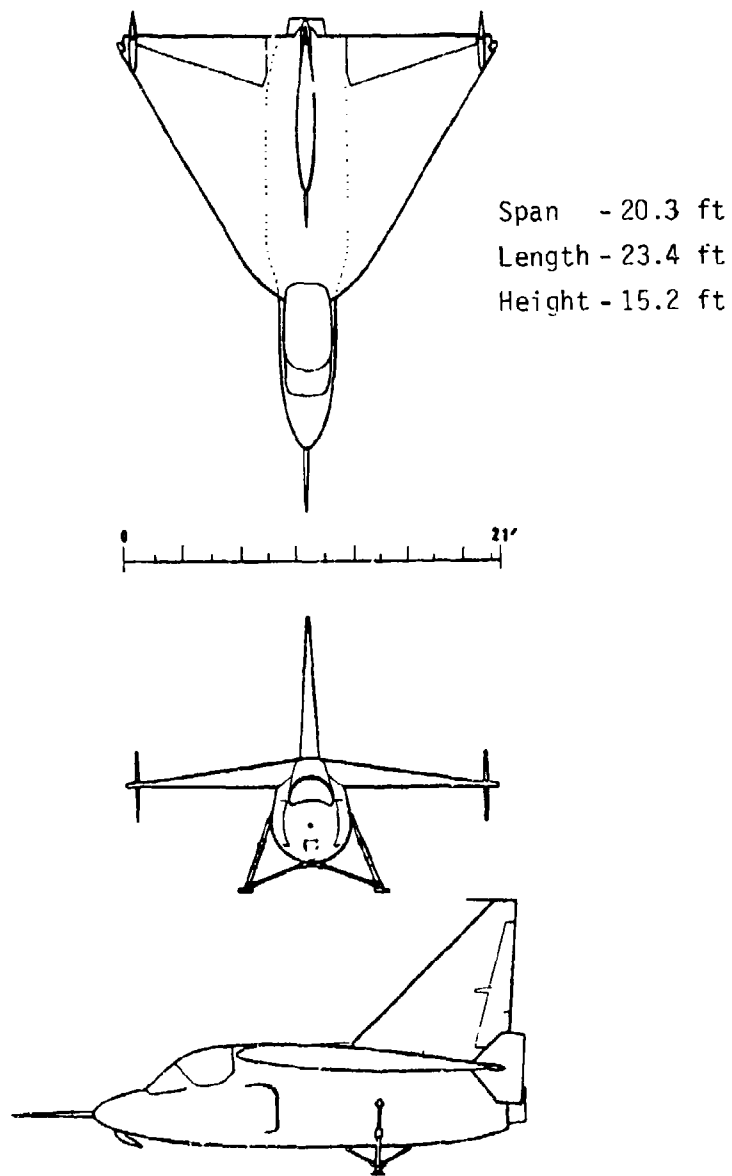

Figure 3.3.2.7 Ryan X-13 General Arrangement  
(Courtesy Teledyne Ryan Aeronautical)

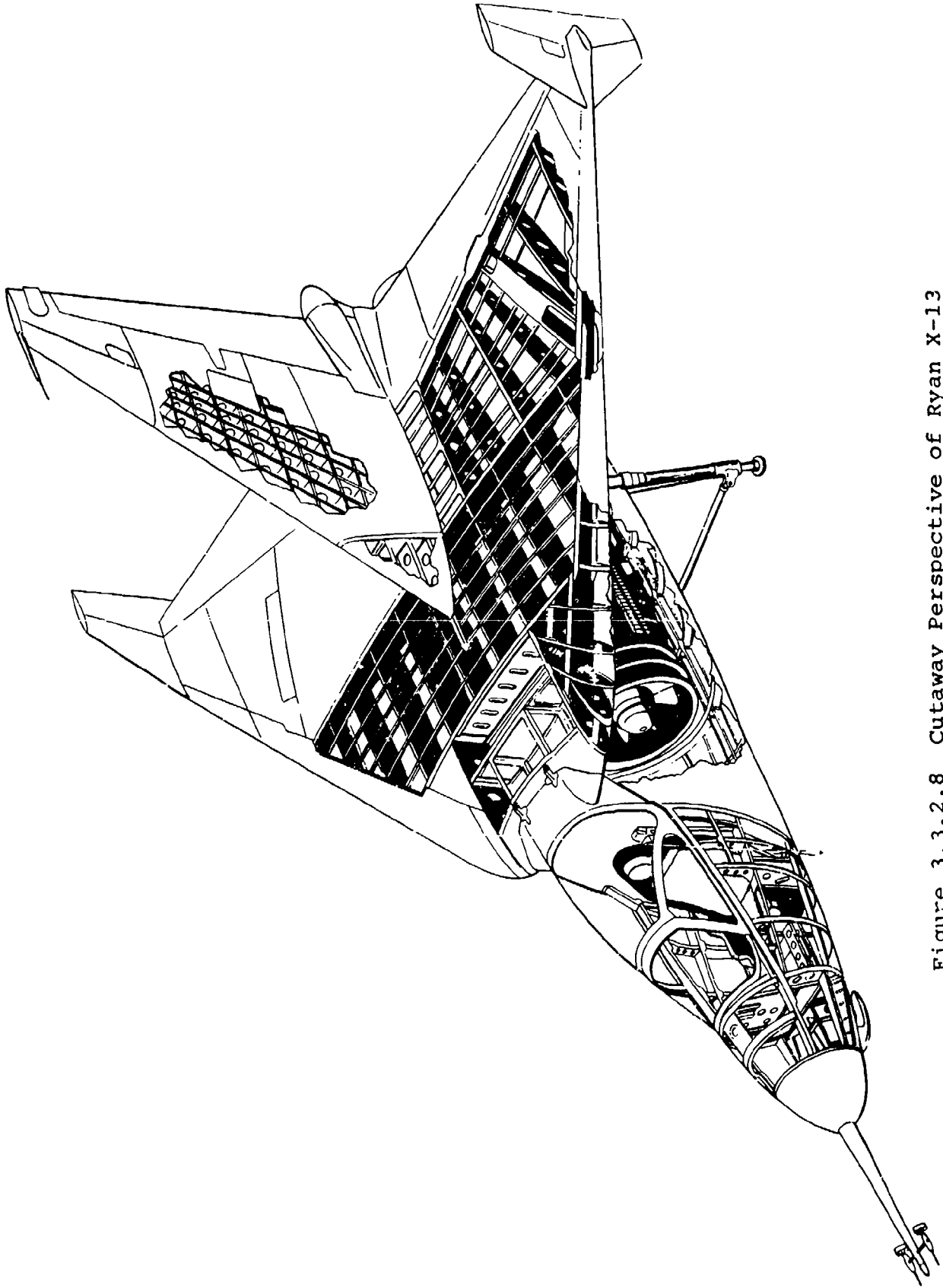

Figure 3.3.2.8 Cutaway Perspective of Ryan X-13  
(Courtesy Teledyne Ryan Aeronautical)

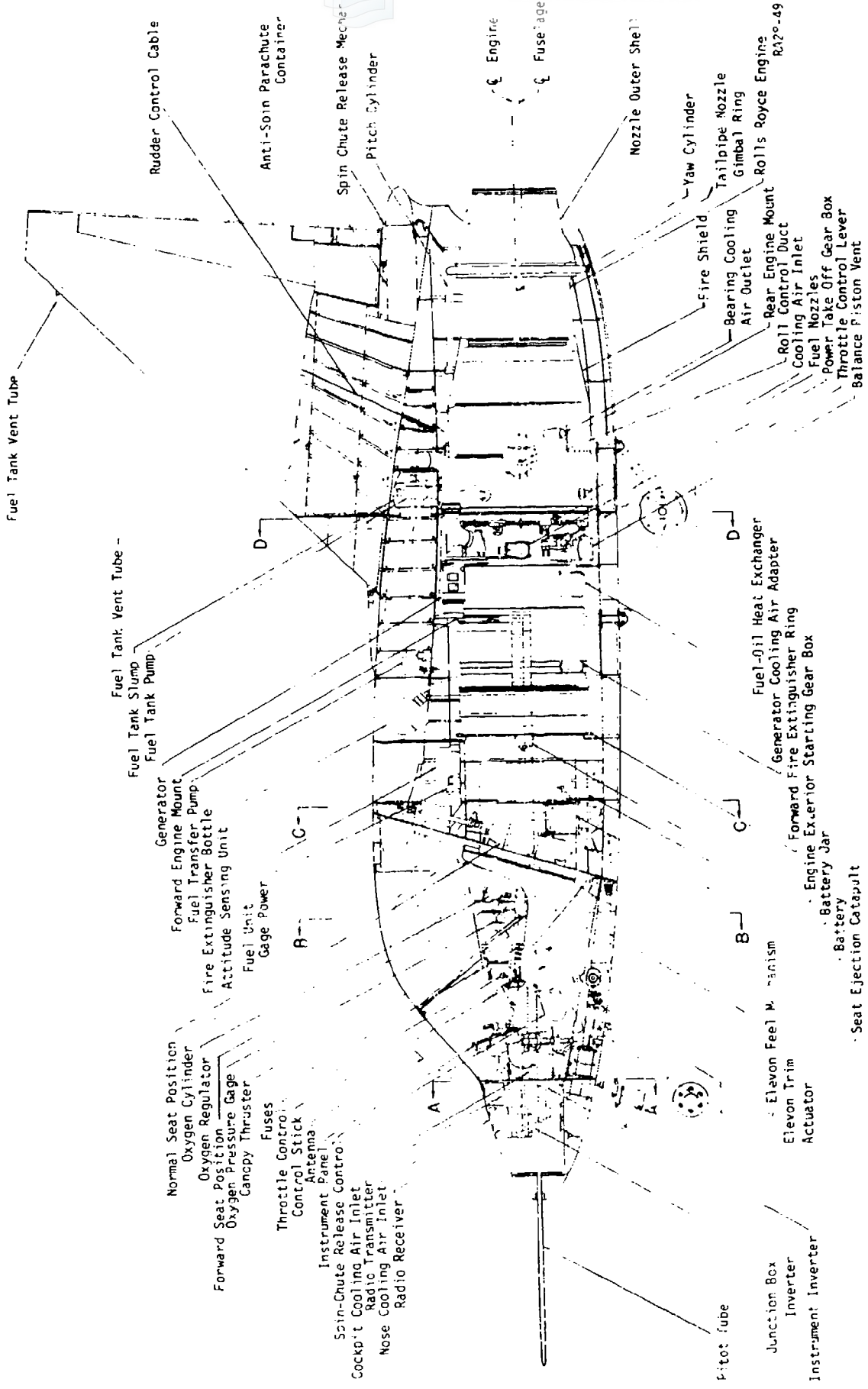

Figure 3.3.2.9 Ryan X-13 Inboard Profile  
 (Courtesy Teledyne Ryan Aeronautical)

angle of attack and gentle stall characteristics. Full-span elevon surfaces were incorporated for roll and pitch control. A high wing position on the fuselage was selected to allow unobstructed airflow into the engine inlets during transition flight. Because of the short fuselage and correspondingly small moment arm between c.g. and vertical tail, a very large vertical surface was incorporated but the tail volume coefficient still was low and wing tip fins were added to improve the directional stability. The vertical tail was mounted above the wing to keep the fuselage belly unencumbered for conventional takeoff and landing and for operation from the tilting flatbed trailer system seen in Figure 3.3.2.1. The fin was attached at the wing's center and rear spars and a conventional rudder surface was hinged to the fin.

Because of the exploratory research nature of the airplane, it was designed to use, alternatively, a conventional tricycle landing gear, a temporary Pogo type undercarriage, or a chin hook plus bumper pad system. The latter was the primary takeoff and landing system, selected because it resulted in the lowest empty weight. Figures 3.3.2.5 and 3.3.2.9 show the installation of the conventional tricycle landing gear. The landing gear fittings in the fuselage were designed to accept also the chin hook and bumper gear components. A good view of the chin hook hanging on the cable appears in Figure 3.3.2.10. Also shown are the upper part of the tilting platform and the X-13 cockpit with the pilot and seat tilted forward for vertical flight. Another view of the hook and cable plus the tripod-like bumper gear appears in Figure 3.3.2.11. Note the blackened area on the concrete below the airplane; this is asphalt which melted and flowed due to the jet blast.

The decision to use the hook and cable system was, in part, made because it was estimated that a Pogo tail sitter type undercarriage would substantially increase the X-13's empty weight. A landing load factor of 4.0 g was assumed for a Pogo system. Actual experience with a large number of X-13 Pogo landings, using the temporary rig of Figure 3.3.2.6, showed the average landing load factor to be about 1.15 g; 1.3 g was exceeded only twice as a result of a partial loss of control on liftoff due to improper assembly of reaction control system components. In retrospect, Ryan believed that a 2.0 g load factor would have been satisfactory and the weight penalty for a Pogo airplane design would have been reduced. But, obviously, the chin hook approach leads to the lowest weight VTOL airplane.

Ryan Aeronautical had determined that it was necessary for the pilot's upper body to be approximately upright in vertical flight to permit him to function satisfactorily. Since the prone position (in conventional flight) was not considered to be a viable solution, a conventional cockpit-tilting seat approach was taken (Figure 3.3.2.10). Tilting of the seat was commanded by the pilot and



Figure 3.3.2.10 Ryan X-13 Chin Hook in Engaged Position on Cable. Pilot Seat Tilted Forward. (Courtesy Teledyne Ryan Aeronautical)



Figure 1.3.2.11 - 1200 Amp Cable Working Down on Airplane  
Ramp at the Flight Form Cable  
(Courtesy of Boeing, from Astronautical)

an upward ejection system was incorporated for emergency escape in conventional mode flight. Figure 3.3.2.12 gives details of the seat and shows its 45° tilting capability.

Except for the seat and sloping instrument panel, the cockpit was of conventional configuration. No provision was made for forward vision through the floor in VTOL flight; the pilot was able to see only upward, sideways and downward over his shoulder. A conventional type stick and rudder pedal control arrangement was used during all flight modes.

The single Rolls-Royce (Avon) RA28-49 non-afterburning turbojet engine, rated at 10,080 lbs maximum sea level static thrust, was installed in the aft fuselage. Mountings and controls for a gimballed nozzle were added to the engine to provide deflection of the jet efflux (thrust vectoring) for longitudinal and yaw control during vertical and transition flight. Longitudinal and lateral nozzle movement was provided by linear hydraulic actuators. Bleed air, continuously extracted from the engine compressor section, was ducted through pipes to a nozzle at each wing tip. These nozzles were differentially rotatable; their thrust could be directed from fully upward (in vertical flight) to nearly horizontal. The amount of bleed air which could be extracted was limited by the engine characteristics.

Both the engine and roll control nozzle thrusts depended upon the engine rpm, ambient temperature and altitude. In addition to the thrust loss due to the roll control system, other losses (intake, cooling air ejector, main nozzle and power "off-take") reduced the basic engine thrust by a small amount. The following table based on information from Reference 3.3.2.4 shows the impact of the losses on the engine thrust using the maximum takeoff operation (7792 rpm and 640°C tailpipe temperature) at standard day, S.L. conditions. "Thrust" of the roll control nozzles is parallel to that of the engine when no roll control (vector tilting) is required.

TABLE 3.3.2.2

ENGINE THRUST, LOSSES AND NET THRUST (S.L. STANDARD DAY)

Basic Thrust	10,000 lbs
Roll control air bleed loss	-1,225
Roll control thrust (total)	+614
Other losses	<u>-156</u>
TOTAL NET THRUST	9,233 lbs

The estimated effect of altitude and temperature (Army Hot Day) was as follows:

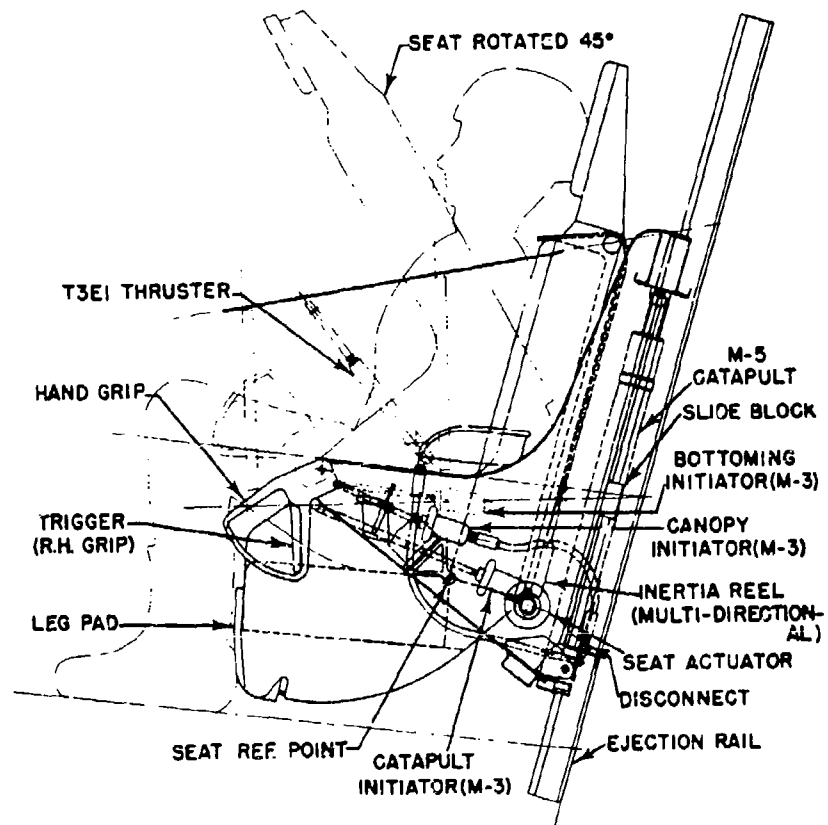

Figure 3.3.2.12 Ryan X-13 Upward Ejection Seat  
(Courtesy Teledyne Ryan Aeronautical)

TABLE 3.3.2.3

NET THRUST AND ROLL CONTROL THRUST VS.  
TEMPERATURE AND ALTITUDE

	<u>Net Thrust</u>	<u>Roll Control Thrust (total)</u>
S.L., Std day	9233 lbs	614 lbs
10,000', Std day	7040	466
S.L., hot day	8160	584
10,000', hot day	6280	432

Operation in VTOL, transition and conventional flight produces conflicting requirements for the air inlets on turbojet/turbofan-powered VTOL aircraft. Hover was favored in the X-13, hence large side inlets with generous lip radius were used. Twin ducts from the inlets converged into a single one leading to the engine. An inlet screen was installed at the front face of the engine for protection from foreign object damage (FOD) and proved to be very effective.

The engine was of the fixed shaft, single rotation type with relatively high gyroscopics, which seriously affected the stability and control characteristics of this small, compact, low inertia airplane.

Because the engine was designed primarily for horizontal operation, Rolls-Royce made some straightforward internal modifications to the lubrication system to permit operation in vertical attitude for extended periods. No significant problems were experienced with the engines during the X-13 flight testing.

The airplane was designed for 6.0 g ultimate load factor at 7000 lbs weight. Figure 3.3.2.8 shows that the airframe was of conventional aluminum alloy construction with a semi-monocoque fuselage and a multi-spar, rib and skin structure for wing and fin. Various items of electrical and test equipment were housed in the fuselage nose and the section aft of the cockpit contained additional electrical, hydraulic, stabilization and test equipment. During the airplane design phase integral fuel cells, located between the front and center spars, were planned to permit carriage of 1768 lbs of JP-4 fuel. But in the actual experimental aircraft, because of weight considerations, tankage for only 1400 lbs of fuel was provided, giving only 17 minutes of conventional flight with a very small reserve, or about 9 minutes of vertical flight with no reserve. During the flight testing, it was found that the fuel load could have been more than doubled without detriment to VTO and hover, but this could not be done because of the limited tankage built into the aircraft.

Located between the main and rear spars of the wing were thin-walled ducts for carrying compressor bleed air to the wing tips. The vertical fin was attached at the rear and center spars of the wing. Originally, combined aerodynamic speed brake/landing platform bumpers were installed on the airplane's belly. As designed, these bumpers proved to be inadequate. With nose gear removed, the CTOL main landing gear, which was a shock absorbing tripod arrangement, was fitted with pads and used as the bumper system. The resulting aircraft had the following weight characteristics:

TABLE 3.3.2.4

WEIGHT BREAKDOWN OF X-13 (from Reference 3.3.2.3)

	<u>Weight lbs.</u>	
	<u>Tricycle Gear</u>	<u>Chin Hook</u>
Wing Group	443.0	443.0
Tail Group (including tip fins and yaw dampers)	78.0	78.0
Body Group	415.0	415.0
Undercarriage (Tricycle Type)	299.8	-
Undercarriage (Chin Hook System)	-	75.0
Flight Control Group	415.7	415.7
Engine Section	69.5	69.5
Engine Installation	2765.9	2765.9
Accessories Gear Box Drive	13.3	13.3
Air Induction System	60.0	60.0
Exhaust System	66.5	66.5
Cooling System	11.1	11.1
Fuel System	100.4	100.4
Water Injection System*	12.3	12.3
Starting System	63.2	63.2
Instruments	41.4	41.4
Hydraulic	213.4	213.4
Electrical Group	310.7	310.7
Furnishings	199.4	199.4
Air Conditioning	10.3	10.3
Empty Weight	5750.3	5530.5
Useful Load	1793.6	1793.6
Crew	200.0	
Fuel Unuseable	27.8	
Fuel Internal	1400.0	
Oil Trapped	4.8	
Oil Engine	10.1	
Oxygen	12.4	
Flight Test Equip.	138.5	
GROSS WEIGHT	7540.9	7324.1

\* Was not installed on the test aircraft.

Flight Control: There were two systems, one for vertical and transition (subaerodynamic) flight and the other for conventional mode flight. During vertical through transition flight, pitch and yaw control were provided by deflection of the engine nozzle (thrust vectoring). Up to  $\pm 10^\circ$  angularity was available in the lateral and vertical planes. Roll control was produced by rotating the wing tip jet nozzles differentially (thrust vectoring). These could rotate up to  $+70^\circ$ , about a spanwise axis, measured from the plane of the wing. The wing tip nozzle thrust level was not controllable.

The motions of the engine nozzle and roll jet nozzles were linked to a conventional stick and rudder. During hover, pitch, yaw and roll control, each could produce up to 3 radians/sec<sup>2</sup> initial angular acceleration; these are relatively high values compared with many other, more recent VTOL aircraft. Such values were not difficult to achieve with the X-13 because of its small size and low moments of inertia:

X-13 Moments of Inertia  
(slug-ft<sup>2</sup>)

<u>Roll</u>	<u>Pitch</u>	<u>Yaw</u>
1800	5010	5610

Height and vertical velocity control were obtained by changing engine thrust, accomplished by the pilot's manipulation of the throttle which commanded engine thrust change through an automatic thrust control system. The pilot's throttle control was designed to permit both large and fine (vernier) throttle movements with the latter being accomplished through a readily disengageable twist grip throttle handle. The system used a single gear which, upon pilot action, engaged teeth in the stationary throttle quadrant and provided  $0.11^\circ$  of throttle movement for each degree of grip twist. This system worked very well and, coupled with the good response of the Avon engine, allowed vertical and translational flight without any significant difficulty.

The automatic thrust control system or, more precisely, thrust-velocity-control (TVC) modified the pilot-commanded thrust level as a function of aircraft vertical velocity. This was derived by lag rate integration of the output from a vertically (airplane longitudinal axis) aligned accelerometer. Height control in hover was satisfactory, requiring only small vernier throttle corrections every 2 to 3 seconds to hold absolutely constant altitude (as in approaching the landing cable) and 8 to 10 second intervals when slight altitude variations were allowed. With the automatic control system off, vertical lift-off was performed without any difficulty; there was no tendency to overshoot the desired altitude. Vernier throttle twist adjustments remained small, increasing to about  $+20^\circ$ . But, in hover, the frequency of

throttle adjustments was significantly increased over that required with the thrust control system on.

Because of the compromised aerodynamic and dynamic characteristics of the X-13 arising from the very large engine gyroscopic forces, a stabilization system was absolutely essential to successful flight. Such a system was incorporated to control the airplane's attitude during hovering, translation and transition flight (Figure 3.3.2.13). Without the stabilization system the airplane was unflyable. Gyroscopic cross-coupling during maneuvering was eliminated through use of control stick lead networks. An important factor affecting the dynamic behavior was the relatively large rotating mass and, consequent, high gyroscopics of the engine which created serious cross-coupling effects (the engine was nearly 40 percent of the flight weight of the airplane). To enhance flight safety two separate electro-hydraulic control systems were used, primary and standby; the latter being employed as an emergency system. The only elements common to both systems were the pilot's controls and the nozzle-moving hydraulic actuators. Either system could be engaged by the pilot at will.

The primary system contained a vertical gyro, angular rate-sensing gyros and integrators, and servo position actuators which moved the jet nozzles. During transition flight, the yaw axis was governed by the attitude reference from the vertical gyro at pitch angles greater than 70°. For pitch angles below 50°, the yaw axis was governed by integration of the yaw rate. Between 50° and 70°, a gradual switching between the two governing systems selected the yaw attitude reference. The pitch axis was governed by the pitch attitude reference of the vertical gyro and the roll axis was controlled by a rate signal, but stabilized at zero roll rate by a roll rate integrator. Higher rate signal gains were used for transition flight than for hovering. All primary system position and rate reference gains, as well as nozzle trim positions, were adjustable by the pilot, normally done prior to lift-off. Electro-hydraulic position servos were used, controlled by solenoid-actuated hydraulic valves driven by servo-magnetic amplifiers. The standby control system, which could be selected by the pilot at any time, used integrated rate references as well as rate damping based on three separate rate gyros.

In conventional mode flight only the elevons and rudder provided control but during transition flight both the aerodynamic and jet reaction controls were active. Because of the poor lateral-directional characteristics due to the airframe geometry and the high engine gyroscopics, it was found necessary, during conventional flight, to provide stability augmentation using artificial roll and yaw damping to obtain satisfactory flying qualities. The roll damping was obtained by operating the elevons differentially in response to roll

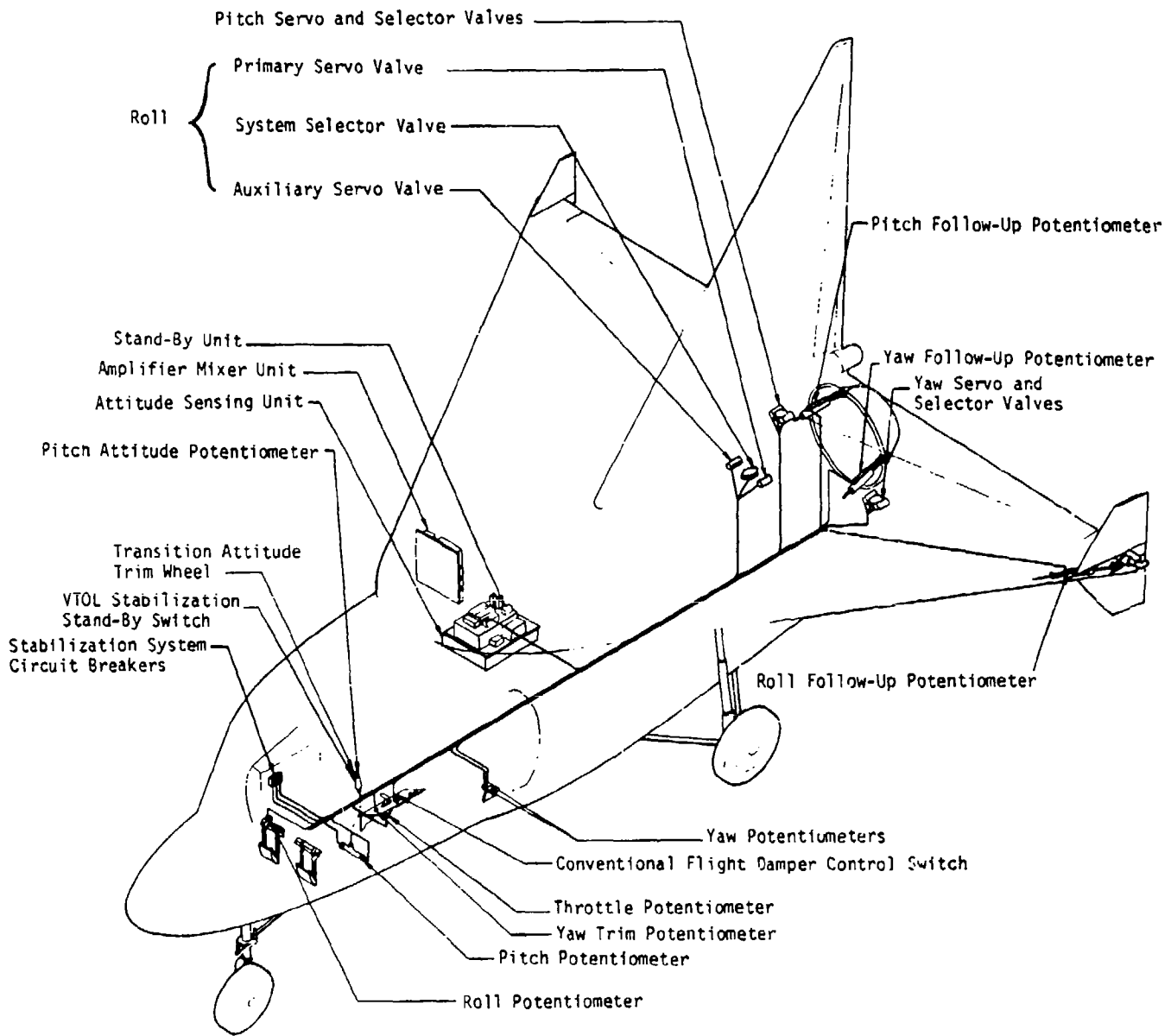

Figure 3.3.2.13 Ryan X-13 Attitude Stabilization System  
(Courtesy Telodyne Ryan Aeronautical)

rate and yaw damping was effected by deflecting the lower portion of the rudder in response to yaw rate and side acceleration. A lead network on the lateral stick allowed the pilot to overcome the roll damper for maneuvering and a washout network was provided at the yaw rate gyro output to permit steady turns.

As with the vertical/transition flight mode stabilization system, two separate systems, primary and standby, were used for conventional flight stabilization. This stabilization system operated throughout transition flight and automatically disengaged when the pilot selected hovering gains in the vertical flight stabilization system. Simultaneously, the roll and yaw dampers were centered electrically.

While the jet nozzle tilting control and the aerodynamic surface controls were both linked to the pilot's stick and rudder pedals, there was an interchange of some functions between vertical and conventional flight. In conventional flight, the cockpit controls produced the normal airplane responses: longitudinal stick motion for pitch, lateral stick for roll and rudder pedals for yaw. During vertical flight, longitudinal stick still produced pitch (and horizontal fore-aft translation), but lateral stick controlled yaw (and lateral translation); the rudder pedals rolled the airplane. When operating in the transition regime, both the aerodynamic and jet reaction forces were used for control, this capability being built into the switching system. During transition a conflict existed between the functions of the two control systems in yaw and roll. Left lateral stick movement caused the jet reaction control system (JRCS) to yaw the aircraft to the left and the aerodynamic control system to roll it to the left. Left rudder caused the JRCS to produce a right roll while the aerodynamic controls diminished. This conflict between control systems led to difficulty during the initial transition flights; the airplane became aerodynamically directionally unstable and laterally stability reversed. This resulted in such behavior as right yaw with left roll. Further, steady state flight could not be maintained between  $32^{\circ}$  to  $70^{\circ}$  (approximately) angle of attack. The JRCS was unable to provide the needed roll control power because, during transition, it was necessary to reduce engine rpm by 18 to 20 percent to avoid acceleration into a climb. The flight technique used was to pass through the  $32^{\circ}$  to  $70^{\circ}$  angle of attack range quickly and take advantage of the airplane's inertia to resist the roll response to asymmetric wing stall.

Modifications and adjustments to the stabilization and flight control systems were made during the X-13 flight testing; analog simulation and the hover test rig (Figure 3.3.2.3) were used to supplement the flight test work.

Ground Apparatus for VTOL: The X-13 was designed for operation primarily from a tilting platform mounted on a

truck-type flatbed trailer, taking off from and landing on a horizontal cable on the trailer as seen in Figure 3.3.2.14. Ryan Aeronautical found, in retrospect, that the platform trailer was overdesigned and that a simpler, less expensive system could have been developed. The features of the platform trailer appear in Figures 3.3.2.14 and 3.3.2.15 and in several previous figures (3.3.2.1, 3.3.2.10, and 3.3.2.11). Two of these platform trailers were built by the Fruehauf Company. Aside from those features normally found in a flatbed truck trailer, the one for use with the X-13 contained a 90° tiltable platform with hydraulic actuation, a perforated platform surface to reduce jet impingement effects, and a horizontal cable attached to two arms capable of limited vertical plane swinging movement. Upward movement of the arms could be automatically actuated either by contact of the airplane with the cable or by an observer on the ground or on the platform (Figure 3.3.2.14). The weight of the airplane moved the arms down bringing the X-13's bumpers against the platform.

The X-13, as mentioned earlier, was equipped with a fixed "chin" hook for engaging the cable (Figure 3.3.2.10) and with two tripod-like, shock absorbing legs with bumper pads.

Since the pilot could see only the outer portions of the cable during "docking" operation, a vertically swingable striped rod was added to the platform to provide him with position cues. Figures 3.3.2.1 and 3.3.2.14 show positions of the cable arms and cueing rod before and after cable engagement. It was found that the rod was desirable but not essential. The use of a single man on the ground or in the "crow's nest" on the trailer, giving directions by hand signal or by radio, was also found to be a convenience but not really required. Landings on the platform were made without any such guidance with no difficulty. During a landing operation, the X-13 approached the platform in a forward sideslip allowing the pilot to see it, turned wings parallel to the platform a short distance from it, moved the fuselage against the cable and had the chin hook engaged by the upward movement of the cable while the airplane held its hovering position. As the engine thrust was decreased, the cable arms moved down under the aircraft's weight placing the bumper pads against the platform, which was then lowered to the horizontal position for pilot egress, aircraft servicing and movement to another location. Take-off was made from the erected platform by increasing engine thrust and lifting vertically off the wire, moving backwards to clear the platform, then sideways or, alternatively, rotating about the roll axis 90° to 180° followed by an accelerating climb into transition and conventional flight. The vertical take-off from a less elaborate wheeled rig, transition to conventional flight, re-transition and vertical landing on a fixed-position type ground rig appear conceptually in Figure 3.3.2.4. An actual take-off sequence is diagrammed in Figure 3.3.2.16. From hover through transition to 180 kts took as little as 12 seconds and covered a distance of approximately 2,000 feet.

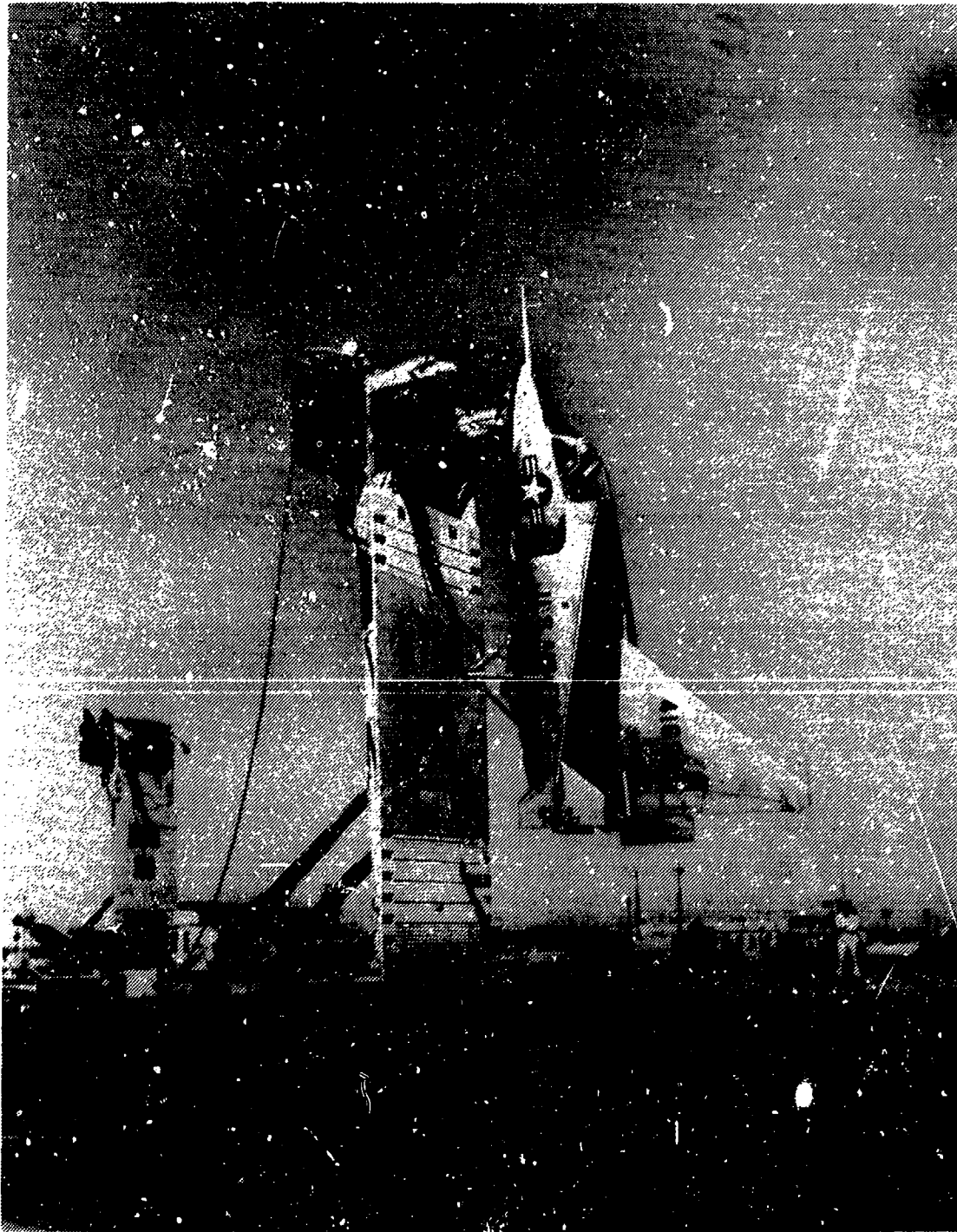

Figure 3.3.2.14 Ryan X-13 Operation from Flatbed Trailer Platform (Note: Standby Trailer Erected at the Left Background)  
(Courtesy Teledyne Ryan Aeronautical)



Figure 3.3.2.15 Ryan X-13 Flatbed Trailer in Horizontal Position  
(Courtesy Teledyne Pyan Aeronautical)



Figure 3.3.2.16 Ryan X-13 Actual Take-Off Sequence (Note: Time between frames was varied to keep the airplane in view) (Courtesy Teledyne Ryan Aeronautical)

Performance Capability: The X-13 was primarily a concept demonstration airplane and not designed to perform a particular military mission. As noted earlier, the speed demonstration requirement was to be 320 kts. Obviously, with the high thrust available, the X-13 could have reached at least high subsonic speed. Other than flight test instrumentation, the vehicle was not required to have provisions for or to carry any payload and the fuel capacity was designed for short duration test flying. The basic flight test missions planned are shown in Figure 3.3.2.17 where flight times of little more than 20 minutes were planned using about 1700 lbs fuel for both the CTOL and VTOL operations. Actually, as noted previously, the fuel capacity was decreased during the building of the airplanes (presumably, because of the increase in actual empty weight over the design estimate) resulting in these reduced flight durations. It was realized during flight test that more fuel load easily could have been carried but internal tankage was not available. Figure 3.3.2.18 gives the X-13's performance as estimated by Ryan Aeronautical. Noteworthy is the 20,000 fpm S.L. rate of climb (at maximum T.O. thrust) and the hovering ceiling of 6000 ft at a T/W of 1.1. These values are at maximum take-off weight and S.L. conditions. The estimated stall speed of the airplane was 121 kts at 7000 lb gross weight.

Ryan Aeronautical Findings: Reference 3.3.2.1 well summarizes the experience and conclusions derived from the X-13 program. The following significant points are extracted from the referenced document:

1. Success of the X-13 - Considering the existing state of the art and the task undertaken, the development problems encountered were surprisingly few particularly in the VTOL and transition flight operations.

2. Vertical Attitude Flight - A very high degree of maneuverability was available and could be performed without any basic difficulty even during rather intricate maneuvers and in relatively strong winds. Roll control power was sufficient to rotate the airplane about its vertical axis in winds up to 50 knots. In hovering flight, the airplane tended to roll to place its wing's lower surface perpendicular to a wind and drift, but this could be handled. Altitude (height above the ground) could be held quite well using the vernier throttle control. Accurate and confident judgements of vertical velocity and position were difficult to make visually above 150 ft altitude. Gusty winds tended to vary altitude due to their effect on the engine inlets and resultant thrust changes.

3. Interchange of Roll and Yaw Control Functions During Vertical Flight - As determined by actual test the system selected (rudder pedals for roll and lateral stick for yaw in vertical flight) was found to be the best approach.

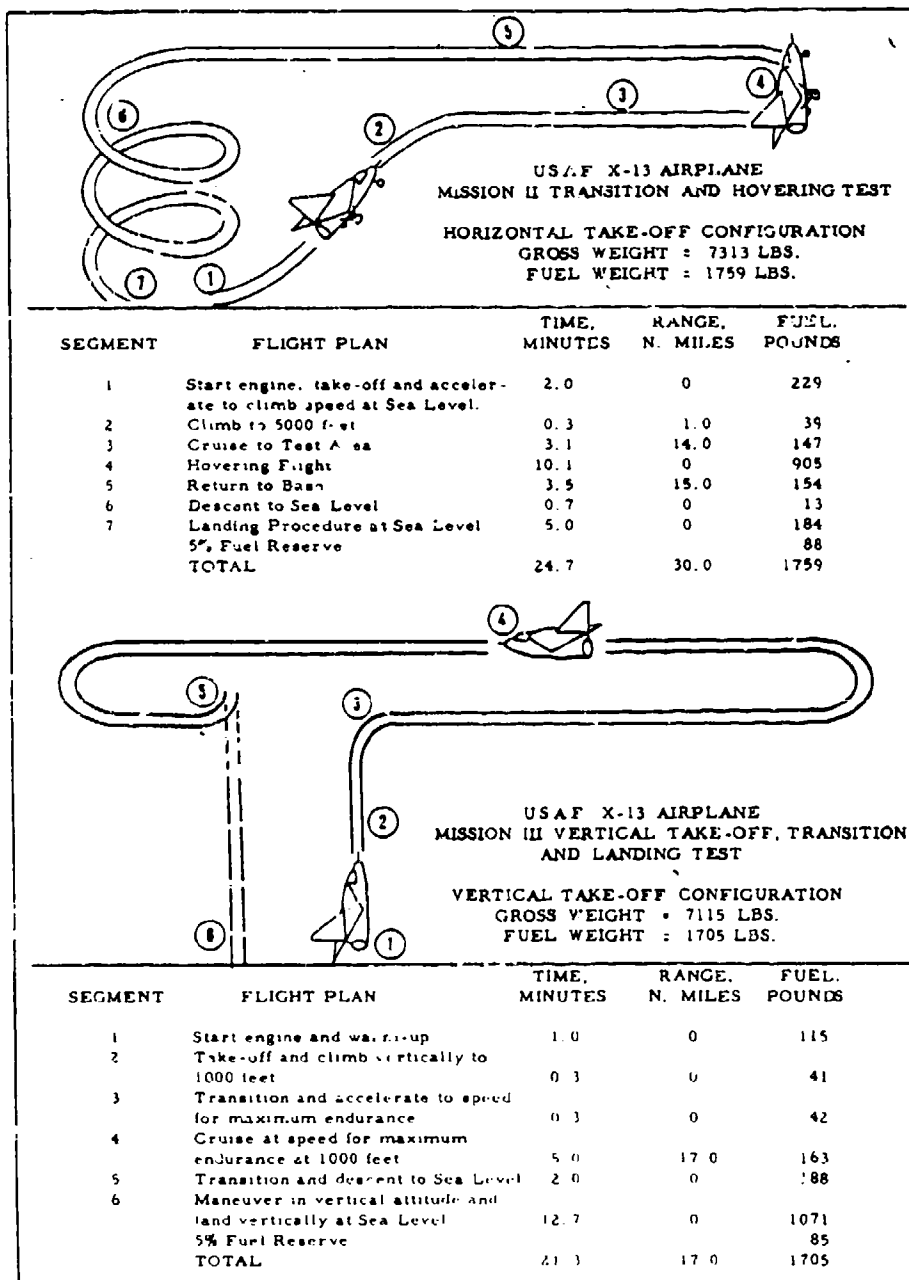

Figure 3.3.2.17 Ryan X-13 Basic Flight Test Missions  
 (Courtesy Teledyne Ryan Aeronautical)

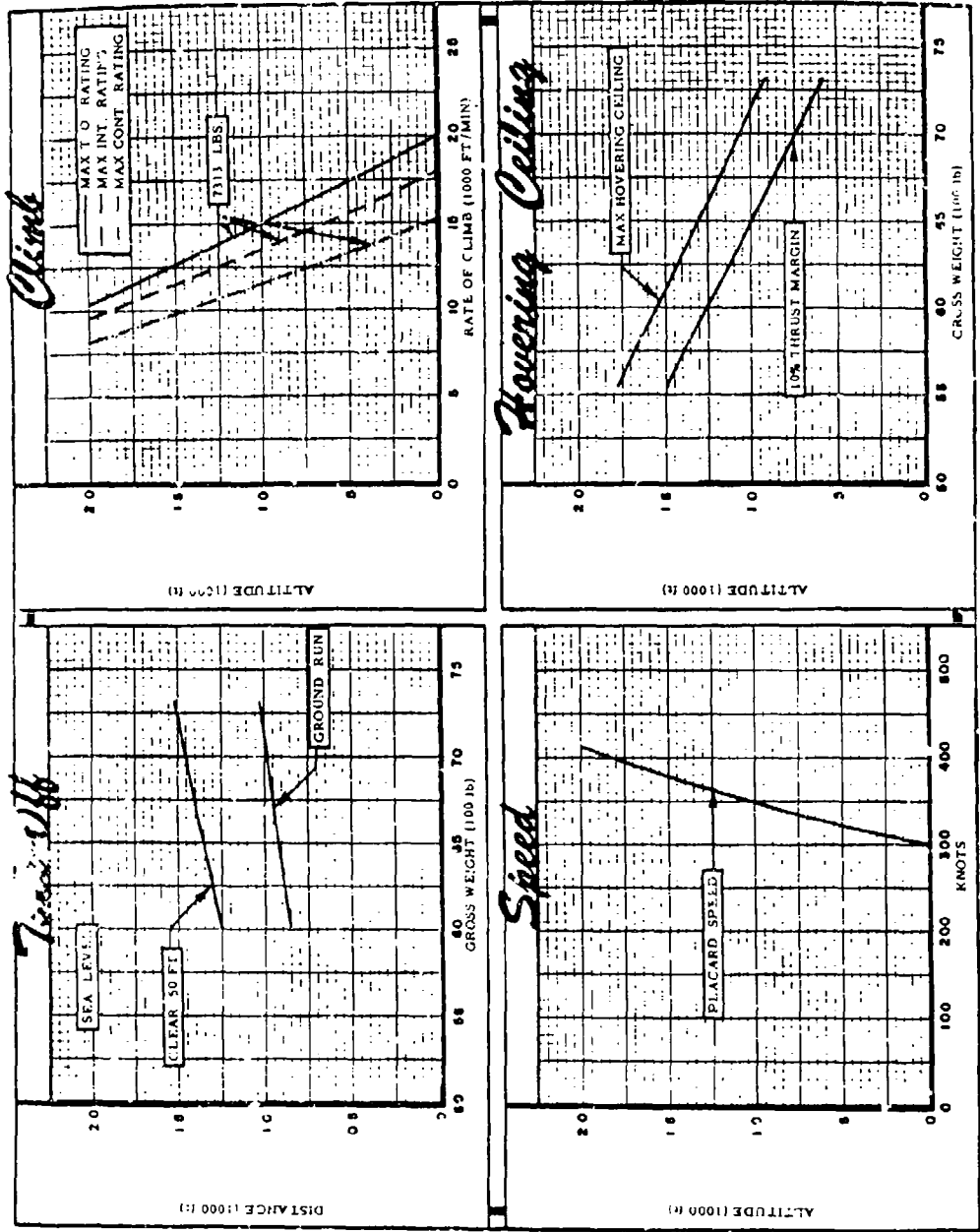

Figure 3.3.2.18 Ryan X-13 Estimated Performance  
(Courtesy Teledyne Ryan Aeronautical)

4. Poor Forward Vision in Vertical Attitude Flight - Not a serious problem and could be effectively overcome during translational movement, as in the approach to a landing area, by using a forward slip and looking out of the canopy side. Landings on the cable could be made without guidance from other personnel because the cable ends could be seen from the cockpit during the engagement operation.

5. Tilting Seat Arrangement - Highly satisfactory. In the forward tilt position the pilot was somewhat cramped but this could be tolerated for the short durations involved. Pilot command of seat tilting was preferred, as opposed to fully automatic tilting, to eliminate relative motion during demanding flight modes permitting him to maintain "feel" of the airplane and precise control.

6. Vertigo or Disorientation - Not experienced in any mode of flight. A slight sense of "breakaway" (detachment from the earth) was noted when hovering at 3,000 to 4,000 ft above terrain.

7. Tailsitter (Pogo) Landing Loads - Found to be quite low based on a substantial number of landings. The average landing load factor was 1.15 g. It was believed that a load factor of 2.0 was reasonable, compared with the 4.0 g value originally thought to be necessary.

8. Effect of Jet Impingement on the Ground - Caused problems over water (spray blocking out vision) below a certain altitude and could cause spalling of concrete surfaces which had absorbed water. Starting at 25 ft the noise level increased in a somewhat exponential manner as the airplane approached the ground vertically. This was readily usable by the pilot as an audio altitude gage and warning system.

9. Check Out of Engine and Reaction Controls - Could be thoroughly performed prior to VTO while still attached to the cable.

10. VTO and Transition Flight - Were easily performed and took place quickly after pilot experience was acquired. No difficulties were experienced even in windy conditions.

11. Visual References for Defining Vertical Attitude During Landing Transition - Poor. A yaw string proved helpful; a flight path indicator, developed near the end of the X-13 program, proved to be of great value.

12. Static Directional and Roll Stability - Reversed at stall resulting in a tendency to diverge in yaw and in a negative dihedral effect. This, coupled with the reduction in jet reaction control (pitch, roll and yaw) due to the relatively low thrust required from the engine during such

flight, would not permit steady state flight at attitude angles between  $32^{\circ}$  and  $70^{\circ}$ . However, changes in the gains of the jet reaction roll control system and flight experience permitted transition flight to be made without difficulty. Such experience included learning the proper proportion to be used of the interchanged control functions of rudder and lateral stick occurring between conventional and vertical flight, as a function of airspeed. The take-off transition (vertical to conventional) was less demanding of the pilot than the landing transition.

13. Deceleration from Conventional to Transition Flight -- Accomplished by stalling the airplane, there being no speed brakes to help dissipate the kinetic energy. This maneuver had to be done gradually, over a long distance to avoid large altitude gains and excessively long vertical letdowns which was not prudent for the X-13 due to its limited fuel supply. A zooming transition, ending in vertical flight, was easiest to perform but approximately level altitude transitions (150 to less than 50 ft altitude change) were the norm once the technique had been learned. (The technique had been developed during the CTOL phase of the flight tests.)

14. Thrust Level with Pitch Attitude - Nonlinear and increased piloting demands during landing transition. As airplane attitude changed engine rpm had to be adjusted manually using a memorized schedule; the schedule could not be followed by feel. Engine rpm (and thrust) tolerance ( $\pm 1$  percent rpm) was close at certain key points to provide the proper reaction control power without causing the airplane to climb during transition.

15. Wing Stall and the Resulting Buffet - Served as a sharply defined demarcation or "transition point" between flight that was predominantly aerodynamic and that which was predominantly thrust supported. The buffeting varied in frequency and intensity and provided the pilot with an additional guide to the progress of the transition (both take-off and landing).

16. Flying Qualities in Conventional Flight - Marginally satisfactory after the addition of roll and yaw dampers. Because of the airframe geometry (short tail length, large and high vertical tail, highly swept wing leading edge and high position of the wing) and large engine gyroscopes (compared with the low inertias of the airplane), a very strong, poorly-damped lateral-directional-longitudinal oscillation was present making the airplane unsafe for flight without the roll and yaw dampers. Even with these dampers, the airplane required very careful handling within severe roll rate and low to negative normal acceleration limitations. (Dynamic simulations revealed that the airplane would diverge and tumble after being subjected to only modest roll rates when the normal load factor was slightly less than  $+1.0$  g).

Concluding Observations - The successful design, development and flight testing of the X-13 was a historically important engineering achievement in VTOL aircraft development. This research program established:

1. The validity of VTOL aircraft based on turbojet (and turbofan) thrust.

2. The validity of the turbojet (turbofan) VATOL aircraft concept including the successful resolution of the question of transition flight between vertical attitude and conventional mode flight. The X-13 was eminently successful in demonstrating the VATOL concept.

3. The ability of a pilot to fly the aircraft, with little difficulty, in vertical attitude using a partial tilting seat and without having any forward vision.

4. The ability of the pilot to land on and take-off from a hang-on platform system as well as on the ground using a Pogo-type undercarriage.

5. The concept of a VATOL aircraft, equipped with a conventional landing gear, alternatively operating in the vertical and conventional attitude take-off and landing modes.

6. The feasibility of engine nozzle deflection (thrust vectoring) for flight control (pitch and yaw).

7. The feasibility of the bleed air-remote thrust approach to flight control (roll).

8. The merit and effectiveness of attitude stabilization systems in vertical and transition flight, as well as in conventional flight, of an aircraft with poor flying qualities.

9. The high effectiveness of the automatic thrust control system for height and velocity control in vertical flight.

Because of its high engine gyroscopics and short-coupled vertical tail configuration a stabilization system was absolutely necessary for the X-13. A well-designed airplane should be able to minimize the lateral-directional coupling found in the X-13 by proper arrangement of the vertical tail, location of the wing, etc. Regarding gyroscopics, modern engines have much lower values because they are lighter (higher T/W) and have reduced rotating mass inertias than the X-13 engine. Further, they can be designed with oppositely rotating components as in the Harrier's Pegasus engine. Also, the use of twin engines, even with same direction-of-rotation, automatically reduces the total gyroscopics compared with that of a single engine of equivalent design and thrust.

The X-13 used a continuous engine bleed air system for roll control and, consequently, suffered, a thrust loss penalty. This can be reduced by using a demand system. Further, thrust loss due to control needs can be virtually eliminated by incorporating systems such as bleed-burn or other types of thrust augmentation.

By today's standards, the X-13 stabilization and control systems were relatively unsophisticated. Present day systems, using modern electronics and fly-by-wire design, would provide much better capability, more reliability and lighter weight.

Although the pilot was able to operate the X-13 successfully in vertical flight, improvement in pilot vision and seating comfort can be obtained by using a tilting forward fuselage nose approach. However, electro-optics now are available to improve forward vision with the tilting seat approach.

The X-13 effort and experience continues to provide good guidance for the design of new VATOL aircraft.

The availability of modern turbofan engines with their greatly improved thrust-to-weight values and lower thrust specific fuel consumptions makes possible VATOL aircraft having vastly improved capabilities compared with the turbojet-powered X-13.

REFERENCES - SECTION 3.3.2

- 3.3.2.1 Girard, P. F. and Everett, W. L., "A Test Pilot Report on the X-13 Vertijet and VZ-3RY Vertiplane," Annals New York Academy of Sciences, VOL. 107, p. 409-427, 1963.
- 3.3.2.2 "Detail Specification, X-13 Ryan Model 69, Vertical Take-Off Research Airplane," Ryan Report No. 6929-36, Apr. 30, 1955.
- 3.3.2.3 "Actual Weight and Balance of USAF Model X-13 Airplane," Ryan Report No. 6944-5.
- 3.3.2.4 "Rolls Royce RA-28-49 Turbojet as Installed in the X-13 Research Airplane," Performance Report No. 6927-12, Ryan Aeronautical Company, Aug. 1, 1954.
- 3.3.2.5 "Vertical Take-Off Research Airplane (Ryan Model 69)," Project MX-1976, Monthly Progress Report, Ryan Aeronautical Company, Report No. 6910-25, Sept. 1, 1955.
- 3.3.2.6 "General Flying Qualities in the Transition Flight Regime Based on Flight Test Results, USAF Model X-13 Airplane," Report No. 6954-10, Ryan Aeronautical Company, Apr. 1, 1955.
- 3.3.2.7 "General Flying Qualities in the Conventional Flight Regime Based on Flight Test Results, USAF Model X-13 Airplane," Report No. 6954-7, Ryan Aeronautical Company, May 11, 1956.
- 3.3.2.8 Solarski, Andrew H., "Survey and Study of VTOL-STOL Stability and Control Characteristics," WADC Technical Report 59-357, Aug. 1959.

### 3.3.3 SNECMA<sup>1</sup>C.450 Coleopter (1951-1959)

Integration of propulsive thrust with aerodynamic lift to form a propulsive wing has potential for improving the flight efficiency of aircraft. The helicopter rotor and ornithopter wing, rotating and flapping (moving) wing systems respectively, represent two types of propulsive wings; the "coleopter" is a third. There are others, to be covered later in this document.

The coleopter (Figure 3.3.3.1) is a radical concept aimed at closely integrating propeller or jet propulsion with an aerodynamic lift system of ring-wing form. Conventional mode flight was to be performed through sole use of this system, without recourse to conventional wing surfaces. It was expected that the integration of the propulsion system with the ring-wing would produce more efficient aircraft than the conventional configurations because of a substantial reduction in structural weight along with a significant improvement in combined propulsive-aerodynamic efficiency, especially in supersonic flight. Because of the resulting ring-wing airplane configuration, VTOL was particularly important to the operating concept.

The inventor of the coleopter is Helmut Graf von Zborowski. His application for the first patent was filed in France on October 4, 1950 and, subsequently, he applied for and was granted a number of additional French patents<sup>2</sup> relating to the coleopter concept. Figure 3.3.3.2 is extracted from the first patent (French Patent No. 1,051,259) and illustrates some of the early thinking regarding propulsive-ring-wing concepts. Shown are propeller, turbojet and ramjet-powered configurations. Von Zborowski was an Austrian engineer who was invited to France in 1948 to develop propulsion system concepts. During World War II he had been responsible for rocket motor development at the Bayerische Motorenwerke (BMW) and designed the rocket motor used in the Messerschmitt Me 163, the world's first production rocket-powered airplane. In 1950 von Zborowski founded his Bureau Technique Zborowski (BTZ) in France to develop new aircraft and missile configurations. Included in the BTZ organization were the Germar engineers, Professor Heinrich Hertel (former Chief of Development at Junkers) and aerodynamicist, Dr. Wilhelm Seibold.

Von Zborowski coined the name "coleopter" for his concept because the annular wing, forming the outer shell of

---

<sup>1</sup> SNECMA - Societe Nationale d'Etude et de Construction de Moteur D'Aviation.

<sup>2</sup> The significant French Patents are: 1,051,259; 1,027,611; 1,033,589; 1,033,590; 1,050,948; 1,063,247; and 1,087,825.

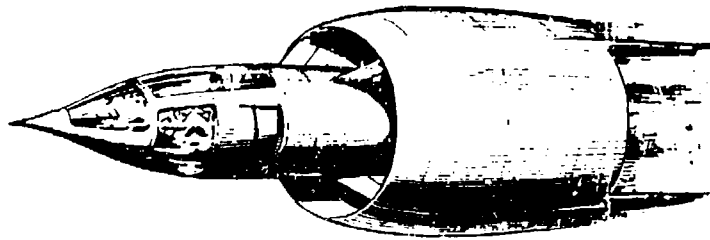

Figure 3.3.3.1 SNECMA Coleopter Supersonic Fighter  
(Courtesy Aviation Age Magazine)

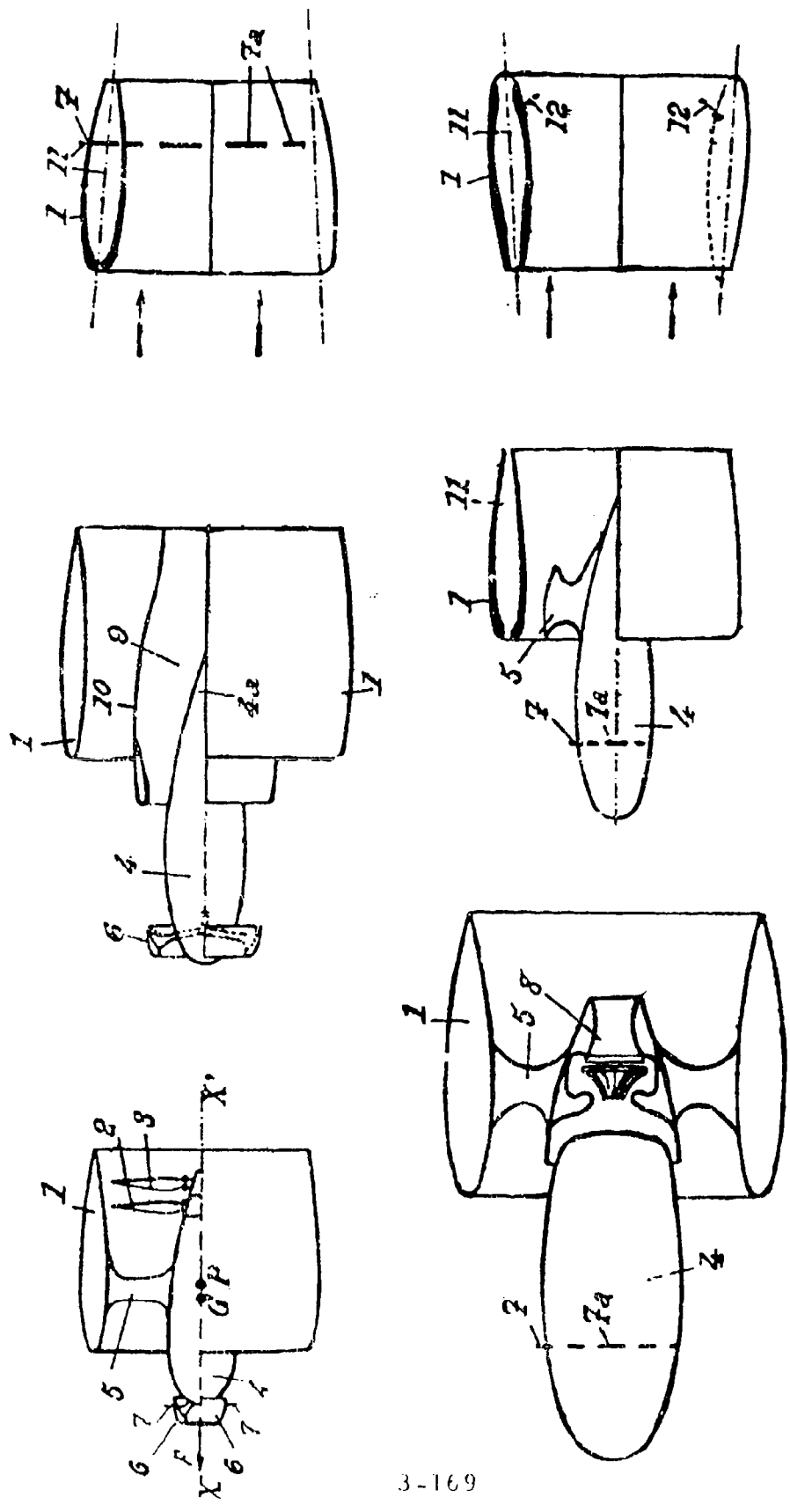

Figure 3.3.3.2 Propulsive Ring-Wing Concepts Covered in Helmut G. von Zborowski's  
French Patent No. 1,051,259

the vehicle, was reminiscent of a beetle, and coleoptera is the entomological term for such insects. Despite some similarities with conventional-wing VATOL aircraft such as the X-13, the coleopter is a radical and unique departure from them, and indeed from any other airplane. The concept was expected to generate a wide variety of VTOL aircraft with speeds ranging from high subsonic to near tri-sonic. Concept application was projected to be in areas such as: private and business aviation, medium size cargo and passenger transports, supersonic fighter, ground attack, remotely piloted vehicles and even missiles.<sup>1</sup> For these various types, two basically different propulsion systems were under consideration, propeller and ramjet, with the first applicable to subsonic flight and the latter to supersonic. This subsection discusses the supersonic coleopter; coverage of the propeller-driven type will appear in a later section of this document. Although they are in the propeller aircraft category and not presented in this section, attention should be called to the conceptual similarity of the coleopter to the Lippisch Aerodyne and the Piasecki Ring-Wing airplane concepts. A basic distinction is the near horizontal attitude on the ground of the Lippisch and Piasecki designs and their use of large angle thrust vectoring. Further, propulsive wing V/STOL concepts of Vought (ADAM concept) and General Dynamics can be considered to be related to the coleopter.

SNECMA, the primary engine company in France, became interested in the coleopter concept in 1951 and was granted a license to the BTZ patents. In 1952 a substantial research and development effort was mounted with BTZ collaborating. This culminated in the C.450.01 aircraft shown in Figure 3.3.3.3. Listed chronologically in Table 3.3.3.1 are the major events in the development.

The first public release of information, in 1954, aroused much interest particularly in Europe, to the extent that the authoritative magazine Interavia gave considerable space to the coleopter in its January 1955 issue devoted to the "The Next Fifty Years" (of aviation). It should be noted that the French government was not financially involved in the development effort, it being primarily a private venture until 1958 when the Federal Republic of Germany's Ministry of Defense (MOD) undertook sponsorship. Originally, the MOD was to contribute about \$5 million to the project with the intention of giving operational development responsibility to the Focke-Wulf Company. But, in 1958, the MOD reversed its decision and withdrew sponsorship because of doubts within the organization regarding the capability of the airplane to perform transitions between vertical and horizontal flight.

---

<sup>1</sup>It is noteworthy that in 1979 the U.S. Army Armament R&D Command awarded a contract to United Technologies Corp., Chemical Systems Division for a study of high performance ramjet (tubular) artillery projectiles.



Figure 3.3.3.3 SNECMA C.450.01 Coleopter  
(COURTESY OF SNECMA)

TABLE 3.3.3.1  
 COLEOPTER CHRONOLOGY

<u>Date</u>	<u>Event</u>
1950	● First patent application made on the coleopter concept (Nov. 13)
1951	● Design studies, R&D started by BTZ
1952	● SNECMA became directly involved in the development effort
1953	● Initial research and development work on concept
1954	● First free hover flight of pulse jet powered remotely controlled model to investigate stability and control (Mar. 31)
	● First public release of information on coleopter concept
	● Construction of hover test bed (engine) C.400 P.1 engine
1955	● <u>Interavia</u> magazine published articles on the coleopter concept (Jan.)
	● Full scale tests of ATAR turbojet engine with changes to permit vertical flight
	● First full scale flying engine test bed completed (ATAR Volant C.400 P.1)
	● ATAR Volant, C.400 P.1 pilotless remote control research vehicle (flying engine test bed) tested in "gyroscopic" rig
1956	● First tethered flight in gantry of C.400 P.1 (over 250 flights made subsequently) (Sept. 27)
	● C.400 P.2 test bed assembled. Basical, a P.1 provided with platform for pilot, ejection seat, instruments and controls
1957	● Tethered tests of P.2 started (Apr. 8)
	● First free flight of P.2 (May 14)
	● P.2 hovered at Paris Air Show (June 1,2)
	● C.400 P.3 construction undertaken, equipped with enclosed cockpit and tilting ejection seat
1958	● P.2 completed 123 tethered and free flights (by Spring)
	● Agreement signed between German Ministry of Defense and SNECMA for collaboration in the coleopter research program; subsequently cancelled
	● P.3 tested on railroad train
	● Nord Aviation undertook construction of C.450.01 airframe
1959	● First hover flight of C.450.01 coleopter (Apr. 17)
	● Crash and destruction of aircraft during vertical flight mode testing. Successful flights were made previously.
	● SNECMA terminated project

In the U.S., interest in the coleopter concept led to studies during 1954-55 by Lycoming Division of AVCO Manufacturing Co. (Reference 3.3.3.6) and by Kaman Aircraft Corp. The latter company's effort was done under a U.S. Navy Office of Naval Research 1955 contract (No. Nonr 1619(00)) as part of their integrated wing-powerplant aircraft research program. (Reference 3.3.3.10 resulted from this contract.)

Between 1951 and 1958 a substantial amount of research, development and design study work on the coleopter concept was completed by SNECMA. This included: model testing in wind tunnels at both subsonic and supersonic speeds, testing of the control and stabilization system in ground rigs and in hover flight using, first, free flight models and, later, full scale engine test beds. Structural design studies and other related efforts also were performed. The results appeared to confirm a number of the projected advantages of the concept--light weight, good cruise aerodynamic efficiency at supersonic speed, acceptable stability and control characteristics in all flight modes, and good VTOL capability.

Testing of the full scale flying engine ("ATAR Volant") test beds C.400 P.1 and C.400 P.2 (Figure 3.3.3.4) between 1955 and 1958 involved a total of about 400 hovering flights, of which a number were fully free (without the safety tether). During 1957 SNECMA contracted with Nord Aviation to build one airframe for the C.450.01 airplane for delivery in early 1958; this was based on a third test bed, the C.400 P.3. The airplane is shown sitting on the ground in Figure 3.3.3.3 and on its transport trailer in Figure 3.3.3.24. The first hover flight of the C.450.01 (.01 for first aircraft) took place on April 17, 1959 at Melun-Villaroche, the French Government's flight test center--a number of hovering flights were completed successfully before the aircraft crashed and was destroyed in 1959. In this last flight several translational maneuvers had been completed at a hover altitude of about 225 ft. After starting vertical descent the pilot, Auguste Morel, sensed a loss of control and ejected. No back-up machine had been built and SNECMA elected to terminate the project later in 1959. Shortly thereafter the German engineers returned to Germany. Several joined the Focke-Wulf organization, and during 1960, participated in the design of a self-erecting tail-sitter fighter (described in subsection 3.3.5) bringing to this design the experience they had acquired during the coleopter effort.

The Coleopter Fighter Concept: The advanced coleopter fighter was to be powered by turbojet and ramjet engine systems and was to be capable of VTOL and flight at speeds between Mach 2 and 3. The radical appearance of the vehicle comes from the large diameter duct used as both the aerodynamic lifting surface (annular or ring-wing) and as the outer shell of the ramjet engine. Takeoff and acceleration to ramjet operating speed were to be made using a conventional

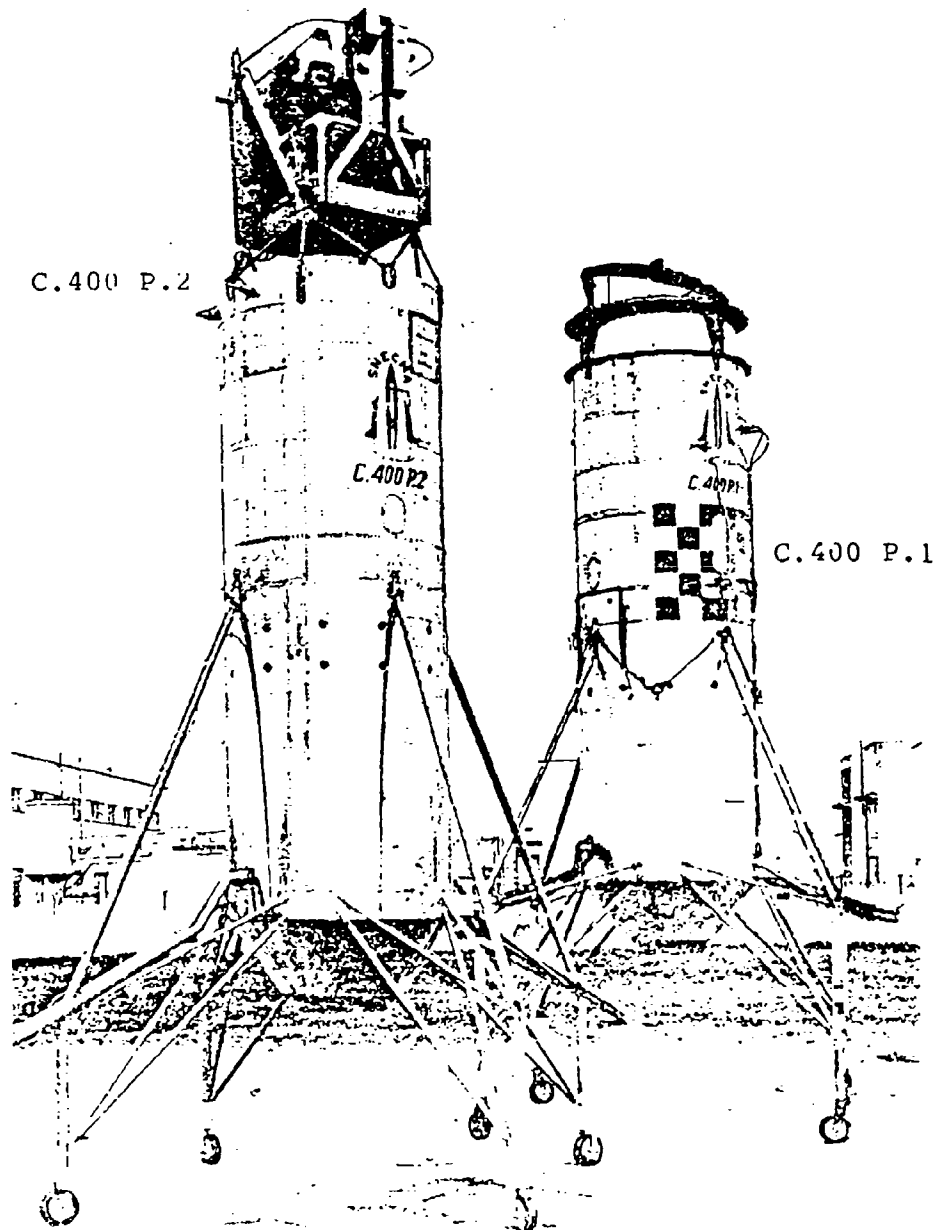

Figure 3.3.3.4 SNECMA "Flying ATAR" Testbeds  
C.400 P.2 and C.400 P.1  
(Courtesy of SNECMA)

afterburning turbojet engine. For short range operations and for special aircraft a rocket motor was an alternative. Because of the coleopter's configuration and restrictive low speed aerodynamic lift and drag capabilities it was poorly suited for conventional takeoff and landing but VTOL, on the other hand, offered an attractive solution. Since relatively high turbojet thrust was needed for rapid acceleration and attainment of ramjet operating speed (beyond transonic), incorporation of adequate thrust for vertical flight did not necessitate a large increase in turbojet engine size and weight. Furthermore, where supersonic cruise flight power was provided by the ramjet engine, the turbojet's fuel consumption was not a primary concern since it could be shut down during supersonic flight. Good propulsive efficiency at supersonic speed, e.g. between Mach 2.0 and 3.0, and at high altitude was expected because of the high rate of air mass flow passing through the large diameter ramjet.

Another merit of the coleopter concept, for fighter type aircraft, was its ability to turn without banking, a characteristic designed into some modern missiles via cruciform wing arrangements. The coleopter, because of its axisymmetrical wing, could generate side force equally as well as it produced lift. Elimination of the bank-before-turn requirement was expected to improve maneuverability over that found in conventional fighters.

Based on the design studies made, SNECMA claimed that a fighter (interceptor) type coleopter, using an afterburning turbojet engine and ramjet propulsion would be capable of reaching 50,000 ft altitude in about two minutes from start of vertical takeoff and attaining speeds well in excess of Mach 2.0. Figure 3.3.3.1 is a far-term projection of the concept. In this version the cockpit was provided with a large amount of transparent area for improved vision in all flight modes. Noteworthy is the elimination of any protruding tail surfaces. A nearer term design is represented, diagrammatically, by Figure 3.3.3.5 wherein the essential elements of a supersonic, turbojet/ramjet-powered coleopter are identified.

The centerbody contained the cockpit, equipment compartments, an afterburning turbojet engine and its inlet ducting, fuel tanks, the thrust vectoring system for vertical flight control, attachments for the ramjet flameholders and for the struts connecting the body with the ring-wing. The ring-wing was designed to contain fuel and some equipment within its structure. External fins and control surfaces were mounted on the outer surface of the wing along with a tail-sitter type undercarriage.

For supersonic flight, the coleopter's nose was pointed to act as a center "spike" and was positioned, relative

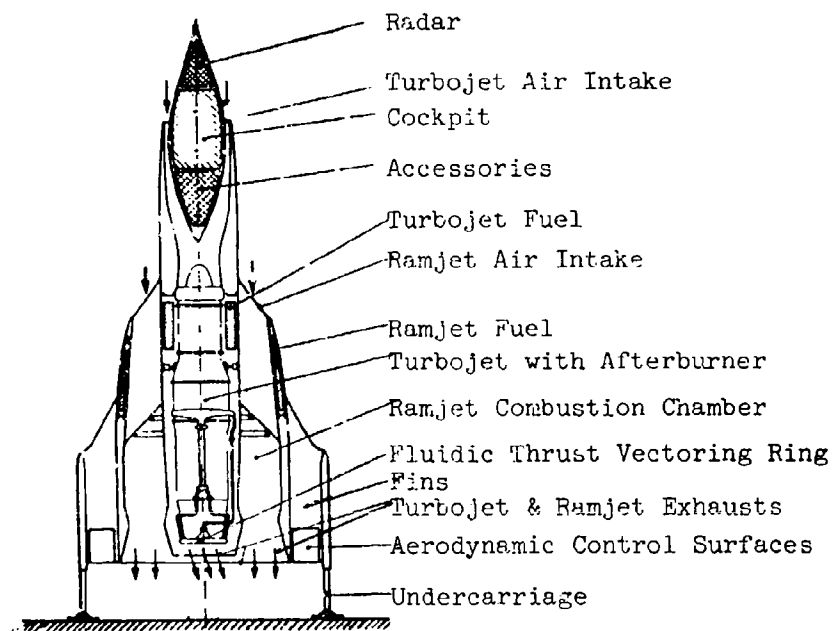

Figure 3.3.3.5 Elements of the SNECMA Supersonic Coleopter Fighter  
(Courtesy Aviation Age Magazine)

to the wing, to cause the streamlines behind the shock wave to be tangent to the wing leading edge in accordance with Busemann's principles for lowest drag. The ring-wing outer surface was shaped to permit an immediate expansion of the flow to reduce pressure and pressure drag.

The overall drag of the vehicle, made up of additive (when shock wave is ahead of the wing) skin friction and induced components, appeared to be sufficiently low to provide respectable cruising ranges on ramjet power. One analysis, made in 1955 by the Lycoming Division of AVCO (Reference 3.3.3.6) concluded that a 7 to 8 foot diameter coleopter of 12,000 to 15,000 lb gross weight would have a range of 1200 to 1500 miles flying between 80,000 and 85,000 ft altitude at Mach 2.5. Operation at higher speed was believed possible, but was thought to pose difficult-to-solve aerodynamic heating problems. Unlike conventionally-winged airplanes, flight of the supersonic coleopter at subsonic speeds does not increase range, primarily because of reduced aerodynamic (L/D). Since the coleopter's large diameter ramjet requires only a low temperature rise, because of the large air mass flow rate, a substantial power reserve is available. Increased drag at supersonic speed affects range more than it does maximum speed.

At reduced speed, low supersonic and below, ramjet power would not be used and the turbojet engine was to provide the full propulsion. While sustained flight at subsonic speed could then be performed, it was visualized that the turbojet engine would be used primarily during takeoff, transition, approach to landing and vertical landing. After vertical takeoff, acceleration to supersonic speed was to be completed quickly with only a short time being spent at subsonic speed. With power off, the airplane was expected to be able to glide but not land safely; the pilot would have to eject.

For the design speeds selected, the diameter of the ring-wing is determined primarily by the aerodynamic capabilities required in terms of lift and efficiency. Supersonic speeds, such as Mach 2.5, drive the wing toward smaller diameters, creating problems in fuel storage and in accommodating the engine size (diameter). Generally, the engine determines the diameter of the central body and this, in turn, affects the minimum usable size of the ring-wing. As mentioned earlier the large diameter of the coleopter (compared with a normal ramjet engine) and resulting large air mass flow rates through the duct require only a small temperature rise to provide the necessary thrust. Since higher temperatures can be generated by the use of additional fuel, large excess power is available. Critical to the success of the supersonic coleopter is the efficient functioning of this ramjet system (Figure 3.3.3.6). The following summarizes critical comments made in Reference 3.3.3.6: Ram recovery is an important consideration, specifically at higher angles of attack. To minimize power losses and to accommodate the different flight speeds, nozzle throat

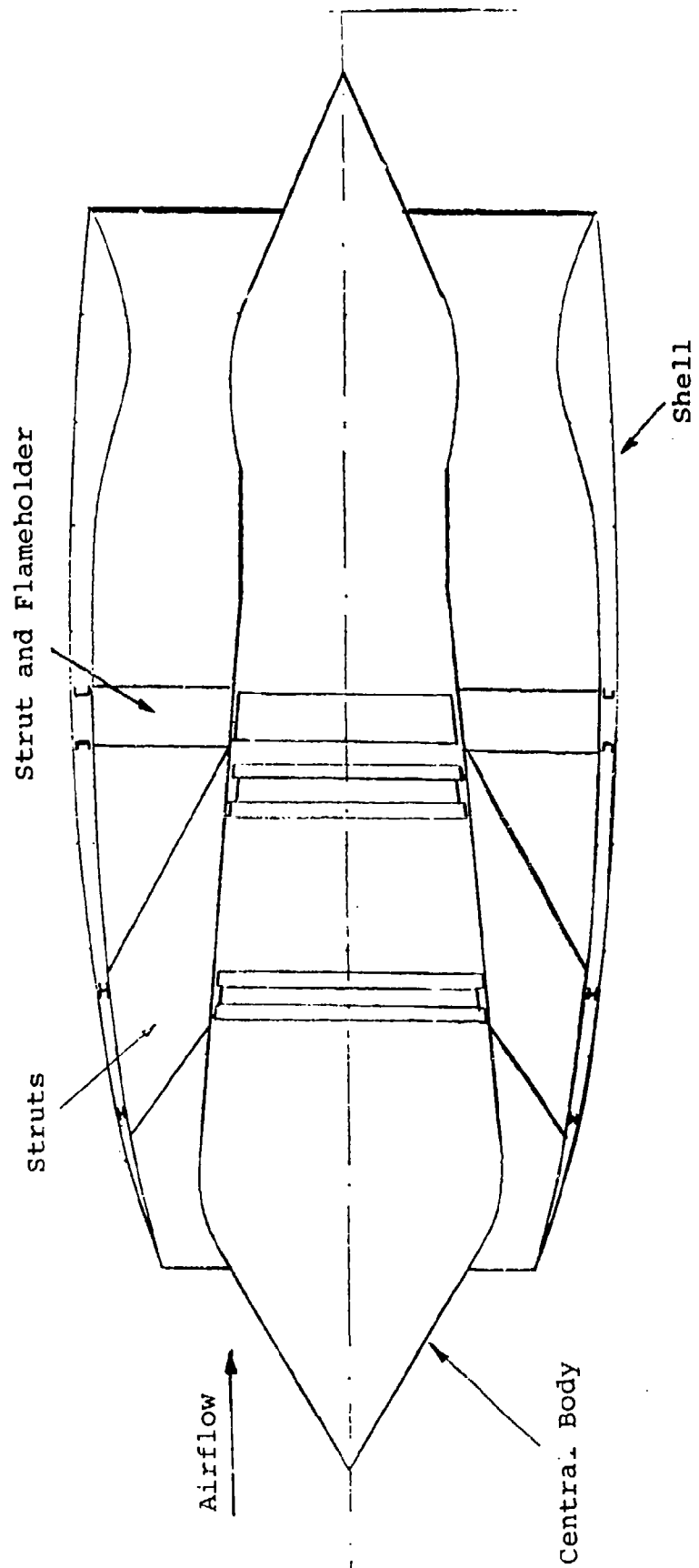

3-178

Figure 3.3.3.6 The Coleopter Ramjet Configuration (from Reference 3.3.6)

area must be controlled, but internal parts of the ramjet will experience large forces. Their movement, for control purposes, can be expected to pose mechanical and structural problems. Combustion in the ramjet at high altitudes and low pressures is of critical importance to the system's success. While the relatively large size of the coleopter ramjet should help alleviate combustion problems at low pressure, the solution to the problem of low temperature combustion is not clear. For example, subdivision of the combustion chamber into zones of different richness can help solve the combustion stability problem but usually decreases combustion efficiency.

An important SNECMA claim was that the coleopter's structural arrangement of centerbody with ring-wing and the inherent structural characteristics of a ring lead to substantial reduction in airframe weight compared with that of a conventional, equivalent performance airplane. SNECMA's analysis indicated that the coleopter airframe would be substantially lighter; this was counted on to help offset the vehicle's lower aerodynamic efficiency. Another merit of the ring-wing was its ability readily to use very thin airfoils, favorable for high speed flight. For the same gross weight and payload of a conventional VTOL airplane configuration, the coleopter's ability to carry a higher fuel load was believed to provide a more-than-competitive flight range.

Based on their analytical work and structural experimentation, SNECMA claimed that a ring-wing for a highly-stressed supersonic airplane would weigh about 40 percent of that of a corresponding plane-wing with the same lifting capability, this despite the larger surface area of the ring-wing. Unlike the plane wing, the ring-wing is a three-dimensional structure which has an inherently high resistance to bending and torsion permitting use of relatively light, low-cost structures and allowing use of thinner airfoils than possible in a plane wing. Because of the ring structure, design for flutter freedom was easy to accomplish. The low cost was predicated on the simple production techniques possible, based on the use of a single wall shell with stiffening rings to form a stressed shell structure, plus a covering skin of easily attached (and removable) longitudinal strips. Unlike a plane wing, the covering skin did not have to be part of the shell, simplifying construction and internal access. Where the wing was to be used as the ramjet duct, the stressed shell was to be on the outside and made of conventional materials. The inside covering would be designed to handle the combustion heat and shield the structure from it.

Airplane control during conventional mode flight was to be through aerodynamic surfaces in the ring-wing trailing edge as on the idealized configuration of Figure 3.3.3.1, or via projecting surfaces as shown in Figure 3.3.3.5. The first approach had the advantage of lower aerodynamic drag but controllability aspects were unknown. During vertical and

transition flight, the turbojet engine's thrust was to be modulated and deflected for control for which three methods originally were considered: vanes in the jet efflux, injection of engine compressor bleed air into the tailpipe exit perpendicular to the engine exhaust flow (fluidic control), and mechanical type spoilers in the efflux area. The vane concept was rejected because of excessive weight but interest in both the air injection and spoiler systems persisted at SNECMA. Figure 3.3.3.7 illustrates the operation of the spoiler system to provide pitch, yaw and height (thrust) control. Thrust variation for height control was to be obtained by varying the efflux area through collective movement of the spoilers (differential movement produced yaw and pitch control). Air injection was the alternative to the spoiler system. The vertical mode flight control approach used on the Flying ATAR test beds and C.450.01 aircraft was based on the air injection method for pitch and yaw; throttle movement was used for height control.

Roll control was visualized initially as being produced by differentially deflecting the engine efflux across the nozzle by means of guide surfaces or, alternatively, by compressor air injection at right angles to the jet (Figure 3.3.3.8). The effect was to produce a torque about the roll axis by causing the efflux to swirl. However, this system was not used in the Flying ATAR test beds and C.450.01 aircraft; outboard reaction jets were employed instead. For the C.450.01 these were located at the wing outer surface.

A stability augmentation system was to be used to provide attitude hold and rate damping about all three airplane axes during vertical and low speed flight and was to be designed to handle both aerodynamic and engine gyroscopic effects. Pilot control was to be via electric signals through the stabilization system to the control element actuators. To relieve pilot workload vertical landing as visualized as being made with the help of an automatic system using height and vertical speed inputs.

The coleopter was to be equipped with a simple, four-legged tail-sitter type undercarriage protruding from the trailing edge of the ring-wing. For servicing and cockpit access, the aircraft was to be tilted to a horizontal position using a special apparatus incorporated into a flatbed trailer. This also provided ground mobility for the coleopter. Figure 3.3.3.24 illustrates the total system showing the transport trailer and the erection of the C.450.01 experimental coleopter into take off position.

The C.450.01 Coleopter (Figure 3.3.3.3): SNECMA's approach to proving the coleopter concept was a three-stage development of an experimental demonstration airplane designated C.450.01. Initially, this was to use the 8160 lb thrust SNECMA ATAR E-5V engine to establish the aircraft's

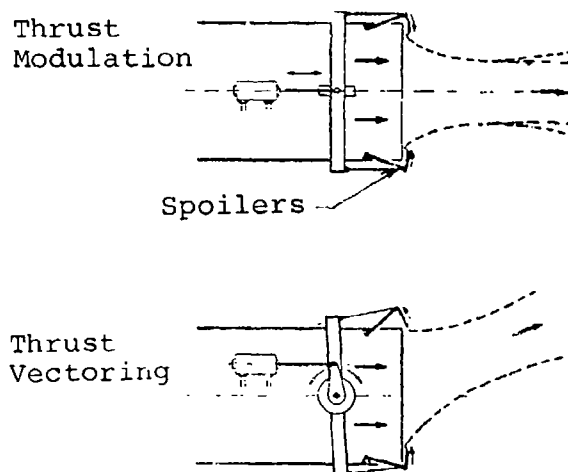

Figure 3.3.3.7 SNECMA Spoiler System for Engine Thrust Modulation and Thrust Vectoring

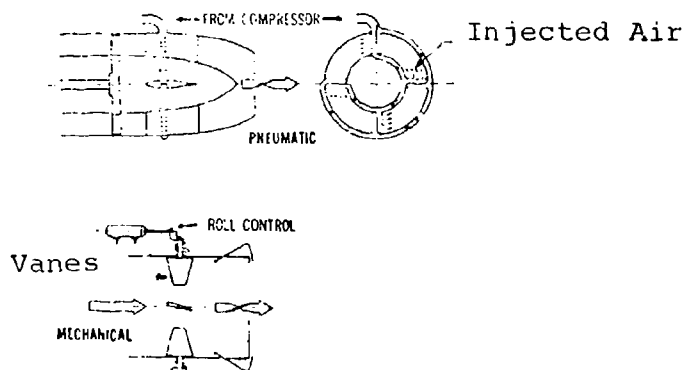

Figure 3.3.3.8 SNECMA Concepts for Roll Control Using Engine Efflux  
(Figures Courtesy Aviation Age Magazine)

capability to satisfactorily perform vertical, transition and conventional mode flight. Subsequently, a more powerful turbo-jet engine was to be installed to increase speed capability and, finally, the ramjet elements (fuel, ignition, burner systems etc.) were to be incorporated for demonstration of ramjet-powered flight. The C.450.01 was completed in 1958 with SNECMA supplying the ATAR E-5 engine equipped with the necessary vertical flight stabilization and controls. Nord Aviation built the airframe and assembled the aircraft under contract to SNECMA. The development of the C.450.01 involved studies, various experimental developments and testing, and substantial design analysis. Some of this work is reviewed later. Figure 3.3.3.9 shows the general arrangement of the C.450.01 and Figure 3.3.3.10 provides some additional detail (note this drawing is of an earlier version of the C.450 design). Figure 3.3.3.11 is an exploded view of the aircraft.

The aircraft was a single-engine (non-A/B) tail-sitter with a single-place cockpit and a relatively short, compact fuselage. Most of the fuselage length was used to house the engine. The fuselage was mounted in the ring-wing with slightly more than half its length protruding ahead of the wing leading edge and with the tail pipe nozzle terminating in the plane of the wing trailing edge. In planform the wing was nearly square, with the chord (9.8 ft) being slightly less than the maximum diameter (10.5 ft). Four streamlined, hollow struts, two vertical and two horizontal, attached the wing to the fuselage. The struts were of tapered, swept-back planform. They joined the ring-wing inner surface, with their 1/4 chord line approximately intersecting the wing's 30 percent chord position. The aft part of the wing was cantilevered about the plane defined by the strut attachment fittings.

Twin, side-mounted air inlets protruded substantially beyond the fuselage sides and supplied air to the engine intake via a bifurcated duct. The air inlet leading edge was canted 25 degrees with respect to the plane perpendicular to the longitudinal axis of the fuselage. Two horizontal, retractable canard surfaces to improve the longitudinal characteristics during transition flight were installed in the fuselage nose. The cockpit was equipped with a conventional canopy and transparent areas were incorporated into the cockpit sides and floor to improve pilot vision during VTOL and transition flight. To accommodate the 90 degree airplane attitude change, a tilting pilot's seat was used. It was equipped with a low-altitude escape system capable of ejection at all tilt angles and flight speeds.

The ring-wing used a 6% thick airfoil. Four relatively small, all-moving, triangularly-shaped tail surfaces were pivotally mounted on the outside of the ring-wing ahead of the trailing edge, two in the vertical plane and two horizontal. Attached to the same basic structure used for the tail

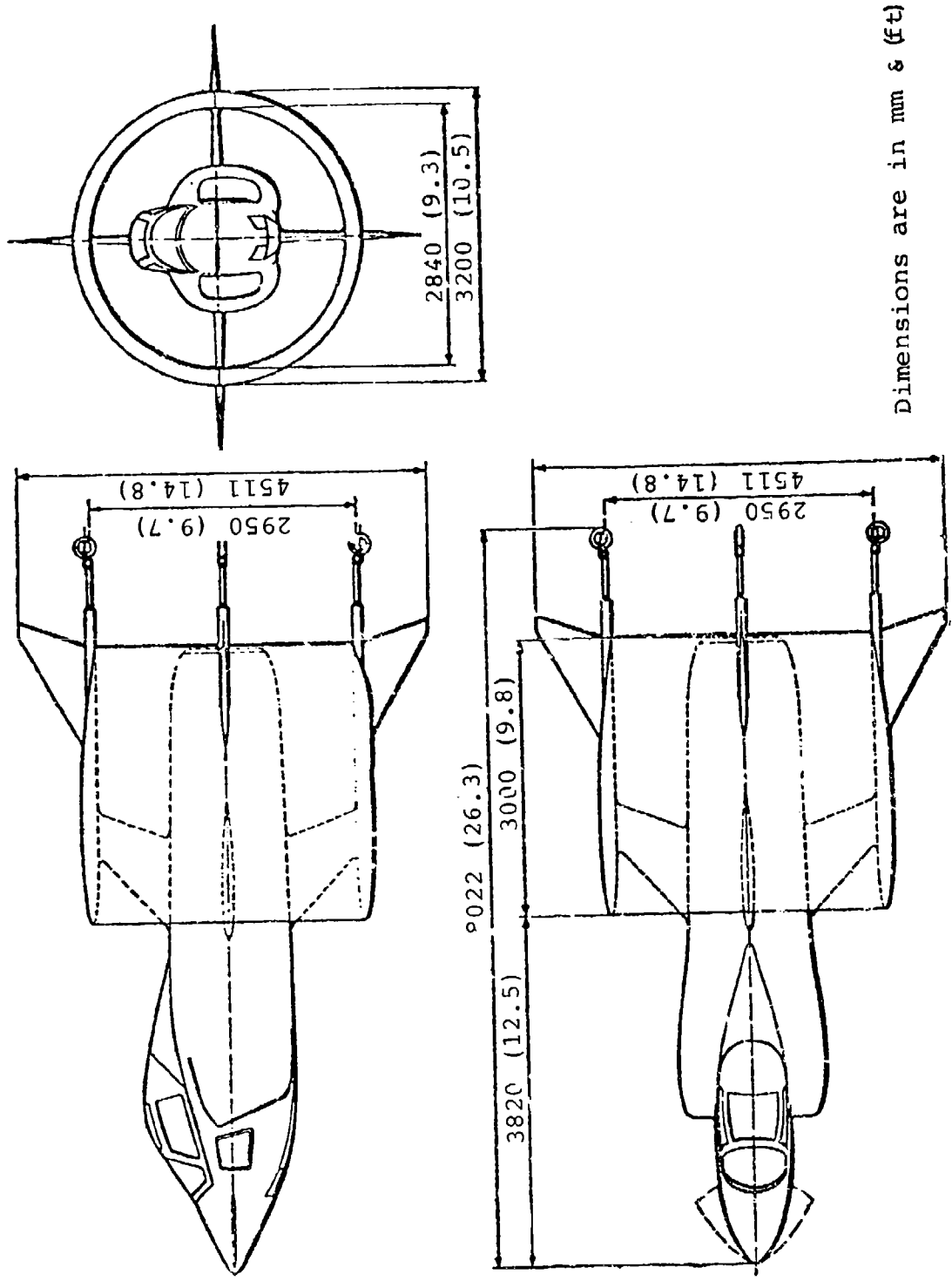

Dimensions are in mm & (ft)

Figure 3.3.3.9 General Arrangement SNECMA Coleopter C.450.01  
(Courtesy of SNECMA)

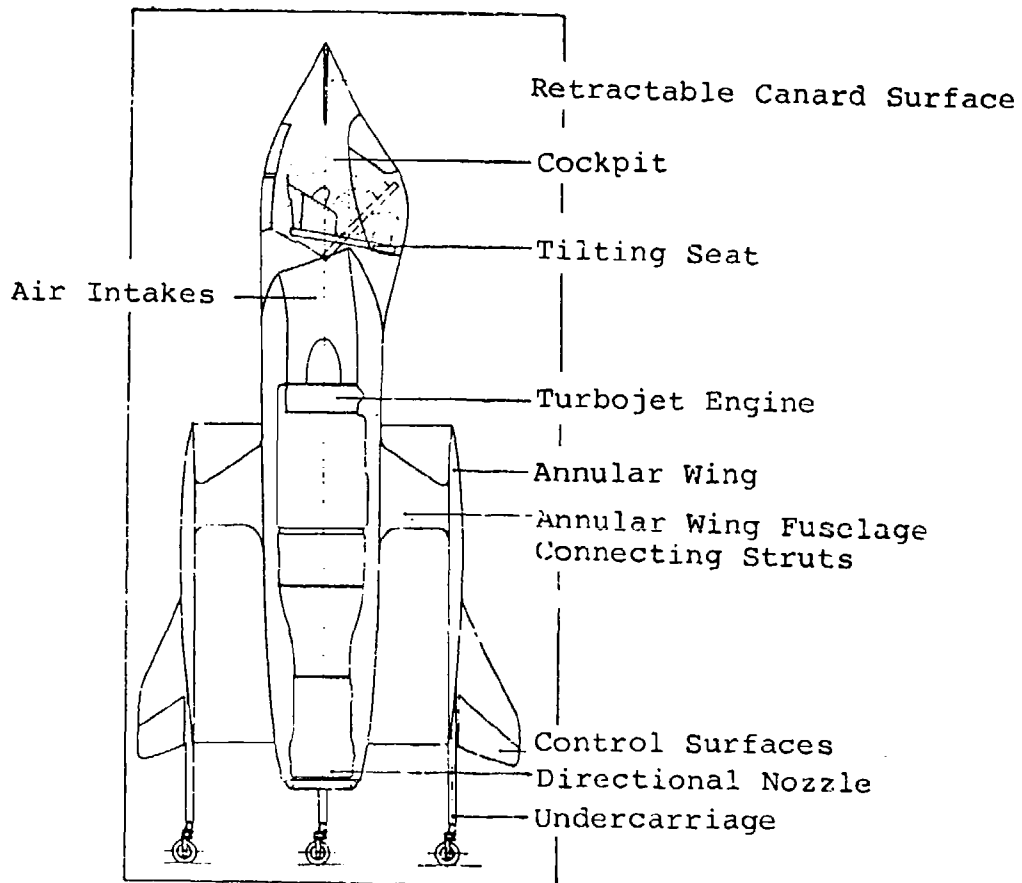

Figure 3.3.3.10 Major Elements of the SNECMA Coleopter C.450 (Earlier Design)  
(Courtesy Aviation Week Magazine)

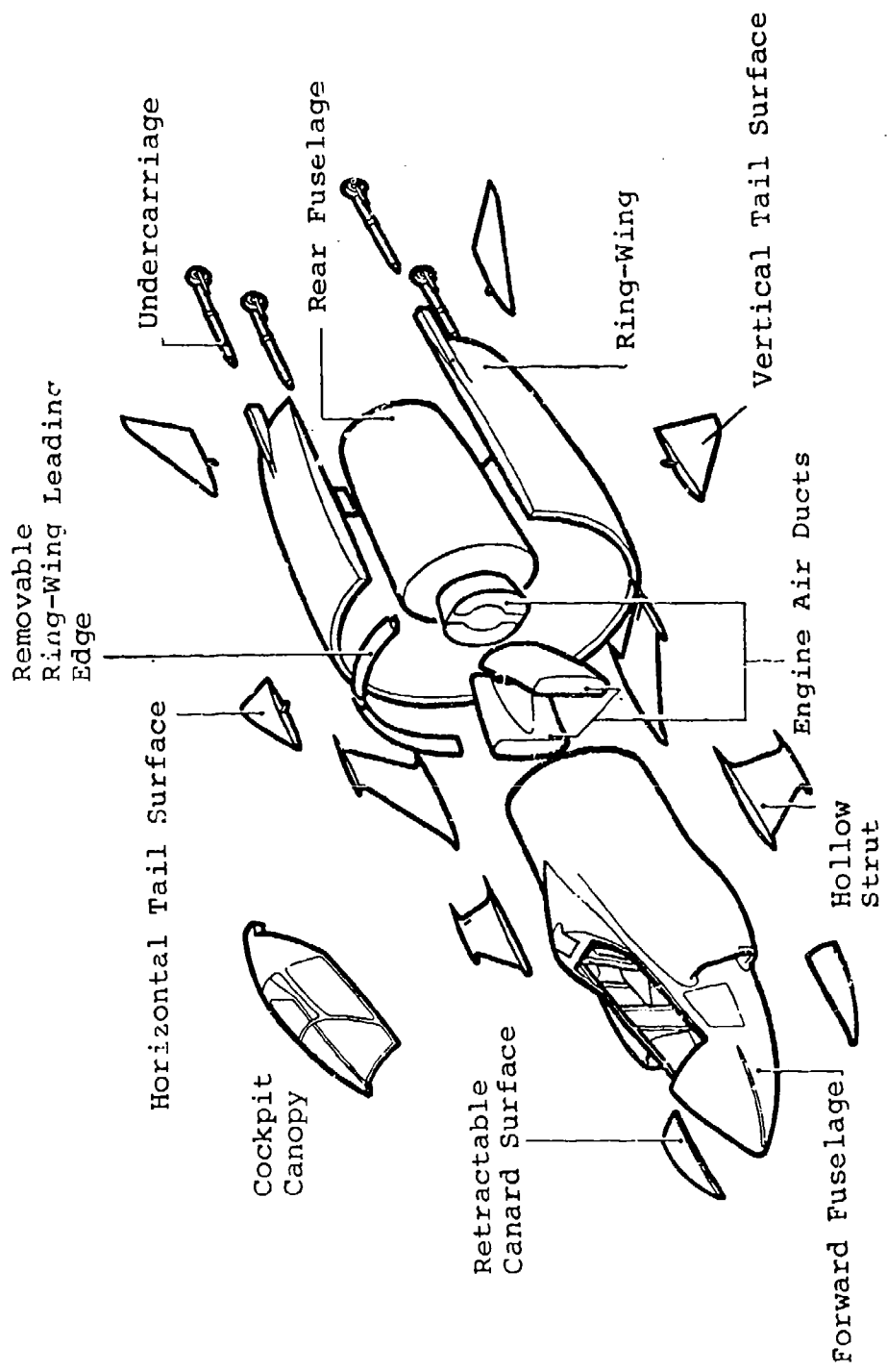

Figure 3.3.3.11 Exploded View of SNECMA C.450.01 Coleopter  
(Courtesy of SNECMA)

surface mounting was the undercarriage consisting of four light-weight, shock absorbing struts with small, castoring wheels. Most of the aircraft's fuel was located within the forward portion of the wing.

Vectoring of engine thrust was used for pitch and yaw control during sub-aerodynamic flight and thrust modulation was employed for height control. Roll control was provided through two sets of reaction jets located at the outer surface (lateral position) of the ring-wing about 1/4 chord aft of the leading edge.

The following table summarizes some noteworthy characteristics of the C.450.01 coleopter:

TABLE 3.3.3.2

C.450.01 PRINCIPAL CHARACTERISTICS

Design Speed	500 mph
VTO Gross Weight	6615 lbs
Empty Weight	4870 lbs
Fuel	1545 lbs
Uninstalled Static Thrust	8160 lbs (S.L. Std Day)
Overall Length	26.3 ft
Overall Width	14.8 ft
Overall Height (Horizontal Attitude)	14.8 ft
Planform Wing Area	97 sq ft
Actual Total Wing Area	305 sq ft
Uninstalled Thrust/VTO Weight	1.23 (S.L. Std Day)

Engine: The engine used in the C.450.01 was the SNECMA ATAR E-5V which was a production E-5 modified for use in a VATOL aircraft. (The appended letter "V" was used to designate the SNECMA engines which were so modified.) Primarily, the modification involved the addition of a vertical flight control system, as identified in Figure 3.3.3.12, and arrangement of the bearing lubrication (oil) system to permit sustained vertical attitude operation. During the period of the coleopter development, 1952-1959, SNECMA had come to believe that the VATOL approach, in its several forms (delta-wing, ring-wing etc.) was a most promising solution to the VTOL airplane and that it would be worthwhile for them to develop VATOL versions of their standard ATAR engine series. To help in this expansion of the product line, current and planned "conventional" engines were to have features which would permit their ready modification for VATOL aircraft use.

The conventional ATAR E-5 was a single-spool engine with the following characteristics:

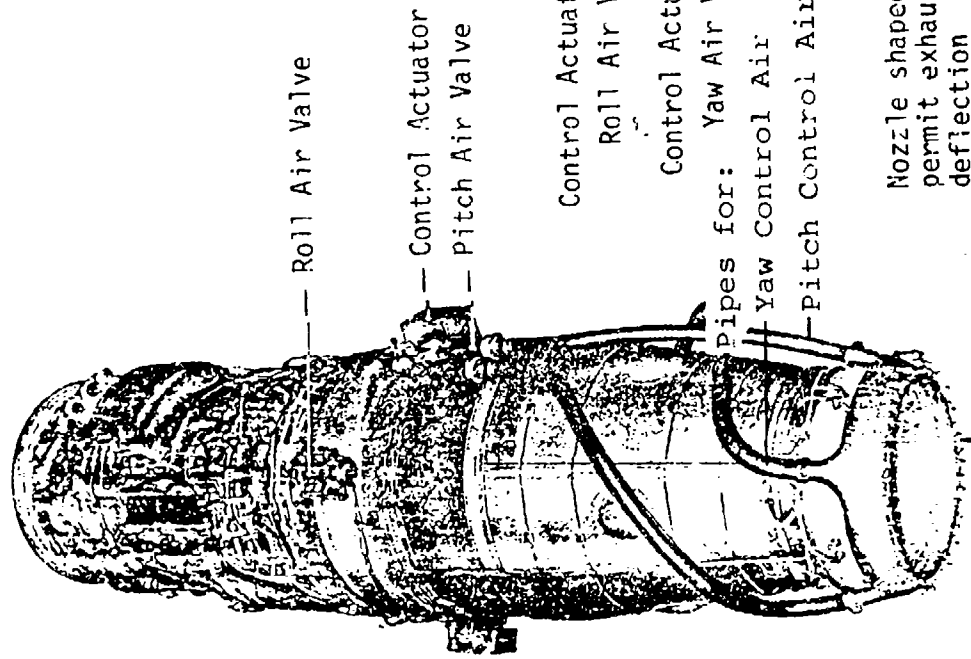
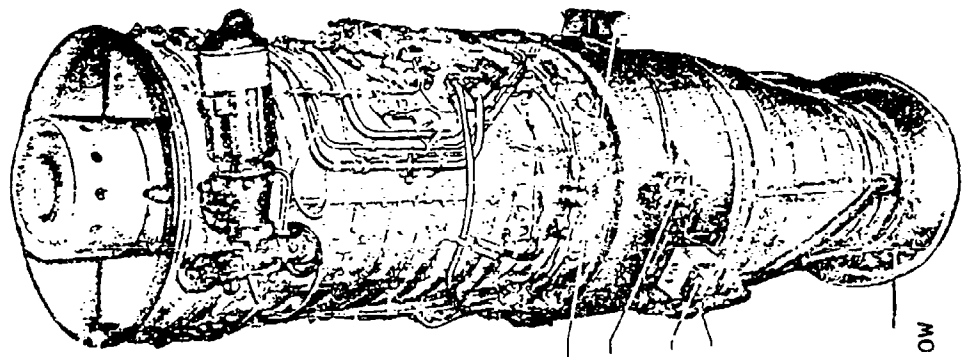
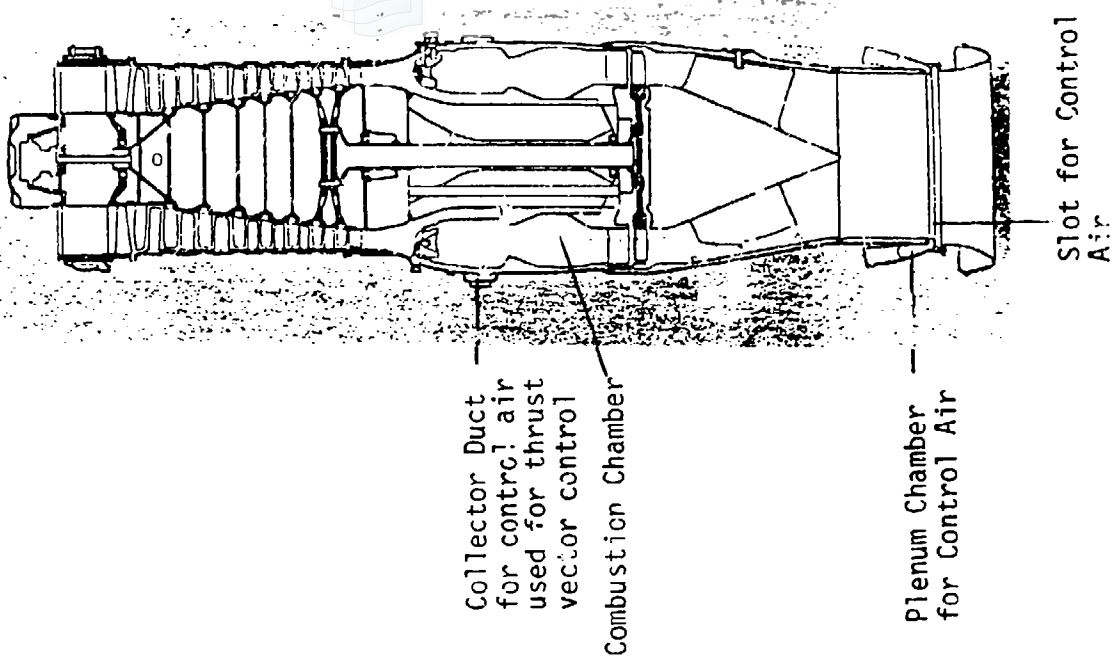

Figure 3.3.3.12 SNECMA ATAR E-5V Used in C.450.01 Coleopter (Courtesy of SNECMA)

TABLE 3.3.3.3

SNECMA ATAR E-5 ENGINE CHARACTERISTICS

S.L. static thrust	8160 lbs
Specific Fuel Consumption	1.06 lb/lb/hr
Compression Ratio	4.8/1
Maximum Diameter	39 inches
Maximum Length	162 inches
Dry Weight	1850 lbs
Thrust/Weight	4.4

Modification to an ATAR E-5V increased the weight somewhat and reduced thrust when air was bled from the engine for control. Also installation of the engine in the fuselage and use of the special VTOL nozzle further reduced the maximum available thrust. The amount of these losses was not available. Figure 3.3.3.13 gives the uninstalled thrust of the E-5 engine for different speeds and altitudes.

The ATAR E-5V modifications were based on the experience obtained with the earlier ATAR D during its modification for use in the flying engine test beds C.400 P.1 and C.400 P.2 discussed later (see Figures 3.3.3.28 and 3.3.3.31). For use as an engine in a VATOL airplane, the additions made to the conventional ATAR E-5 shown in Figure 3.3.3.13, were:

1. Installation of an annular duct around the engine in the vicinity of the combustion chamber to collect high pressure compressor air (bleed air).
2. Piping of the bleed air from this duct to three electrohydraulic valves which controlled the air flow to the thrust vectoring (flow deflecting) nozzle and to the roll control nozzles.
3. Three electrically controlled actuators, one for each of the above valves.
4. Pipes leading from the pitch and yaw air control valves to an annular chamber surrounding the tail pipe exit. The chamber served as a plenum and was divided into four separate, equal segments. A peripheral slot in the inner chamber wall, at the entrance to the thrust vectoring exhaust nozzle, selectively injected bleed air at a right angle to the engine exhaust flow. Essentially, this was a fluidic control system.
5. A curved, divergent exhaust nozzle attached to the above duct and designed to permit efficient deflection of the engine efflux in response to the injection of the bleed air.

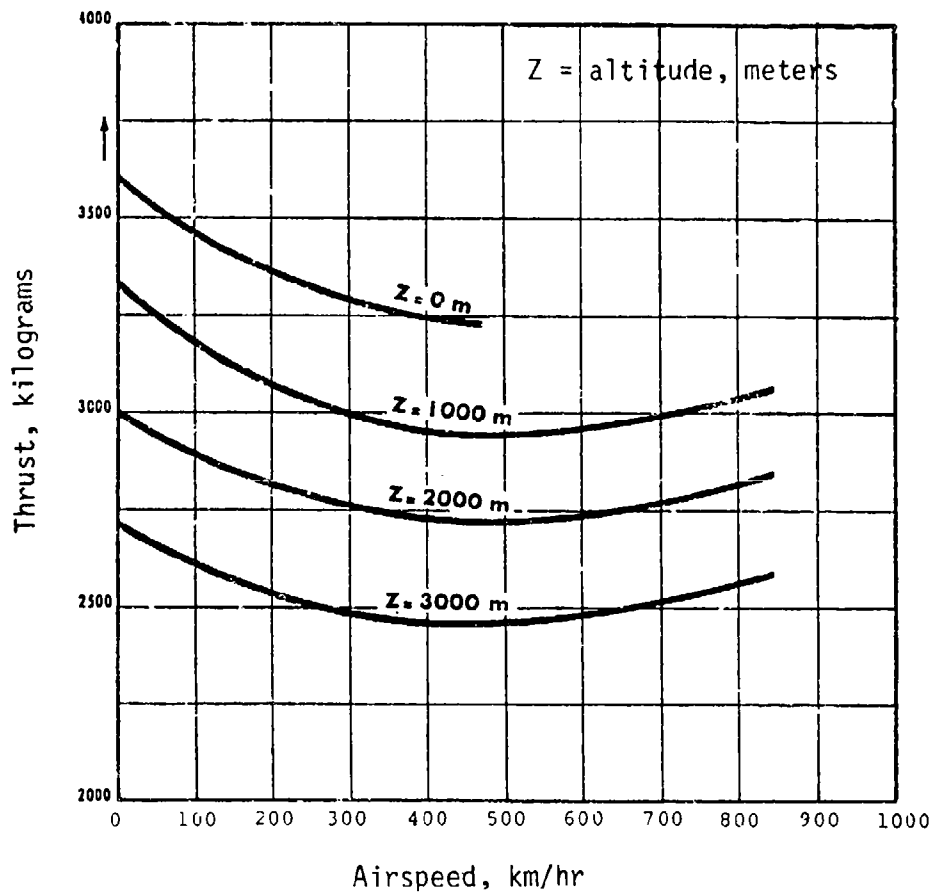

Figure 3.3.3.13 Thrust vs. Airspeed SNECMA  
ATAR E-5 Turbojet Engine  
(Courtesy of SNECMA)

6. Ports on the roll control valve for attachment of lateral pipes (not shown in Figure 3.3.3.13, but shown in Figure 3.3.3.32) leading to the reaction nozzles on the outer surface of the ring-wing.

This engine arrangement was well-proven by the extensive development of the C.400 P.1 and P.2 Flying ATAR engine test beds. Several hundred flights had been successfully completed on these vehicles prior to providing the E-5V engine for the C.450.01 coleopter.

Based on the flight experience, SNECMA considered the vertical flight mode pitch, yaw and roll control system to be satisfactory.

Airframe: The outstanding structural element of this airplane is its wing. All of the other major elements-- fuselage, tail surfaces and undercarriage are keyed to the wing and integrated with it. Figure 3.3.3.14 shows the construction of the ring-wing, designed to exploit the inherent characteristics of ring structures to obtain low weight and reduced production cost compared with conventional wings. The reduced cost arises from the rotational symmetry of the ring-wing while the lowered weight comes from its nature as a three-dimensional structure. Unlike a plane wing it has, inherently, a high resistance to bending and torsion permitting the use of relatively light construction. In an ideal design, the air and mass forces are carried by the tubular shell in direct balance so that there are no substantial bending moments. However, in practice the wing cannot be a simple thin-walled shell because it must have sufficient stiffness or stability to be free from structural oscillations and have the rigidity to resist the ovalizing forces present, particularly at the strut supports where the forces are large and concentrated. Hence, the shell must use a stiffening structure, but only one skin is required (inner or outer) to act as a stressed shell dimensioned for rigidity and strength. The second skin is primarily an aerodynamic covering braced to the stressed shell.

The C.450.01 six percent thick wing was made of aluminum alloy material with the inner surface acting as the stressed shell. Three major stiffening rings were attached to the exterior of this shell along with about 20 secondary rings used to stiffen the thin shell material. Protruding from the rear of the outer wing surface to beyond the trailing edge were four rectangular tubes designed to provide attachment and cantilever support for the landing gear struts and also to incorporate a journal bearing system for the all-moving tail surface. The loads from the rectangular tubes were transferred into the main and rear circular spars, using conventional wing rib-type longitudinal structure, and distributed to the inner skin via these ribs, spars and auxiliary stiffening rings. Attachment of the four fuselage-to-wing struts was through fittings fastened to the main circular spar and positioned to

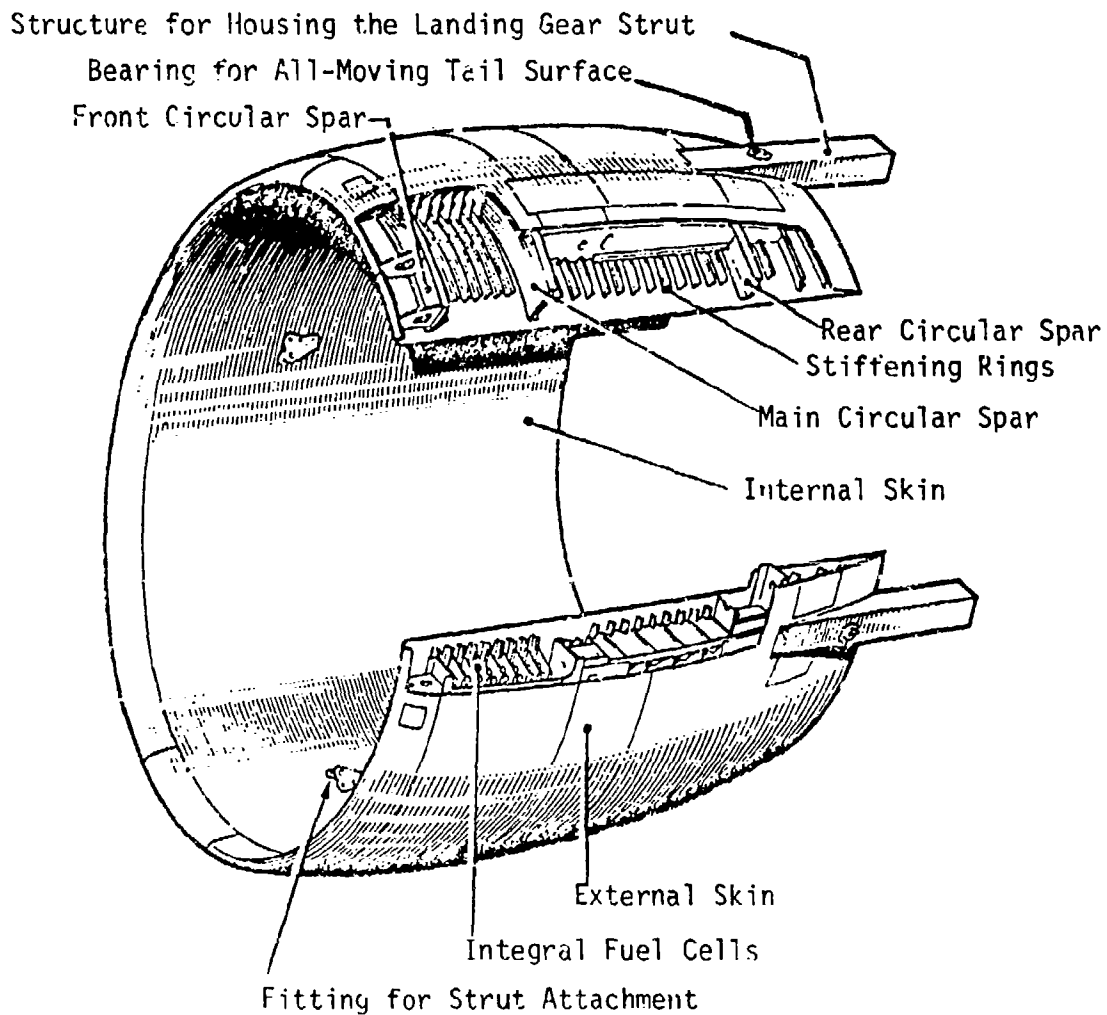

Figure 3.3.3.14 SNECMA C.450.01 Ring-Wing Structure  
(Courtesy of SNECMA)

transfer landing loads directly to the wing structure supporting the rectangular tubes. Almost all of the fuel, approximately 1540 lbs, was contained within the wing structure between the front and main circular spars and the outer and inner skins; the circular formers for the outer skin acted as baffles. The tank was divided into four separate compartments by rib-type longitudinal walls. A removable, four-segment reinforced leading edge was attached to the front circular spar. The outer skin, not being required to function as a stressed shell, was made readily removable in those areas requiring access to the inside of the wing.

The annular wing had a 9.9 ft mean diameter (10.5 ft maximum diameter) and 9.8 ft chord, giving it a total geometric area of 305 sq ft. However, a ring-wing, being a form of biplane, has an equivalent monoplane span of twice its diameter. According to SNECMA the equivalent monoplane lifting area of the C.450.01 wing was 18 sq meters (194 sq ft) derived from the theoretical determination that the equivalent monoplane area =  $2 \times \text{dia} \times \text{chord}$ . This gives an equivalent monoplane wing loading of 34 lb/sq ft. SNECMA stated that the equivalent monoplane unit weight for the ring-wing was 12 kg/m<sup>2</sup> (2.40 lb/sq ft). Thus the wing, designed for 500 mph speed at sea level, weighed approximately 476 lbs. This is 7.2% of the gross weight or 9.8% of the empty weight of the airplane. (For the F-4E the comparable values are 13.9 and 16.7%.)

The all-moving tail surfaces (Figure 3.3.3.15), were assembled to the ring-wing at the journal bearings, fitting closely against the structure in neutral position. These surfaces were of simple, conventionally built-up, aluminum alloy, two-spar stressed skin rib and stringer construction. A tubular shaft, attached inside the tail surface to the inboard ribs and front spar, terminated in a root end projection designed to fit into the ring-wing journal bearings and carry the tail surface loads into the wing structure.

Figure 3.3.3.16 shows one of the four landing gear assemblies designed to fit into the rectangular tubes projecting from the wing trailing edge. All four assemblies were identical and were specially built by Messier. The units were composed of: an oleo-pneumatic shock strut, a 360° free-castering dolly type 250 mm (9.8 inch) diameter wheel with smooth solid rubber tires of rectangular profile and a brake which could be locked in the "on" position. When installed in the wing, only the telescopically moveable part of the oleo strut projected from the wing rectangular tubes. SNECMA assumed that the landings always would be essentially vertical and at low sink speed. Designed for these conditions, a total landing gear weight of only 176 lbs was achieved (2.7% of the VTO weight).

The four identical streamlined struts (Figure 3.3.3.17) for attaching the wing to the fuselage were of

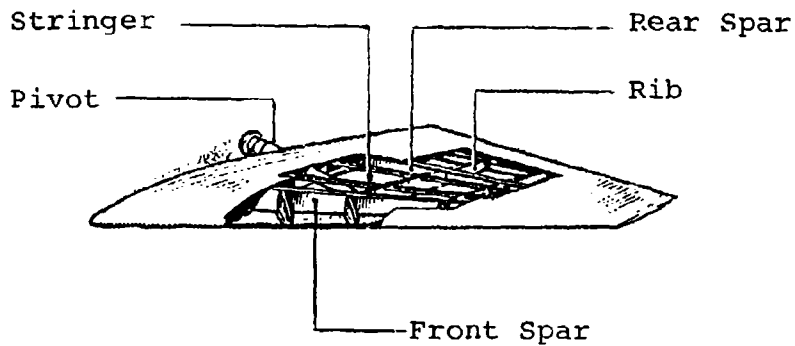

Figure 3.3.3.15 All-Moving Tail

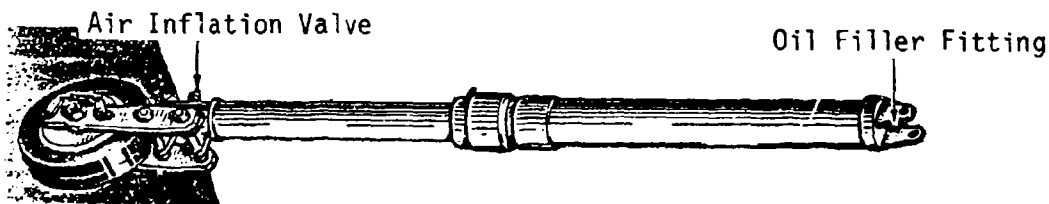

Figure 3.3.3.16 SNECMA C.450.01 Oleo-Pneumatic Landing Gear Assembly

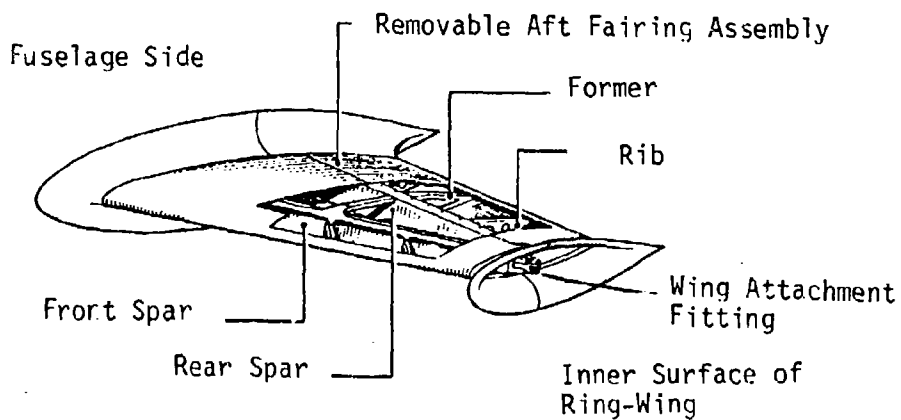

Figure 3.3.3.17 Fuselage-to-Wing Attachment Strut  
(Courtesy of SNECMA)

conventional aluminum alloy construction using two spars, ribs and a stressed skin. A fitting at the outboard end of the struts attached the wing to the strut; the section aft of the rear spar was removable. Passing through the two lateral struts were the pipes supplying bleed air to the roll control nozzles located at the sides of the ring-wing. Hydraulic and electrical lines passed through the vertical struts.

The fuselage was of conventional but compact design having a minimum length established by three components: a streamlined nose (with retractable canard surfaces), the cockpit and the engine (see Figures 3.3.3.10 and 3.3.3.11). Conventional aluminum alloy construction was employed. The placement of the wing-fuselage struts permitted the engine to be located essentially aft of the airframe structure and to be conveniently removable by sliding it backward out of the airframe as illustrated in Figure 3.3.3.25b. The rear fuselage, not being attached to the ring-wing was lightly loaded and primarily a fairing for the engine. For fire safety, the fuselage was divided into three isolated parts and the engine compartment was provided with forced ventilation.

The cockpit and its equipment were designed to accommodate both the vertical and conventional flight modes. Figure 3.3.3.18 is a view into the cockpit from above which shows:

- A conventional instrument panel in front of the pilot containing most of the flight instruments.
- A special instrument panel at the left side placed in good view of the pilot with the seat in forward tilt position. Flight instruments on this panel were a variometer, a timer, engine tachometer and artificial horizon. These were duplicates of those in the conventional instrument panel.
- Transparent areas in the floor and sides.
- A control system consisting of a single, floor-mounted stick and two throttles, one for conventional mode flight and the other for use in vertical mode. No rudder pedals were incorporated.
- A tilting ejection seat.

Figure 3.3.3.19 is an inboard side view of the pilot's seat and control stick. A Sud Aviation ejection seat, Type E.120B was used; this was designed to operate under zero and conventional airspeed conditions. Powered electrically,

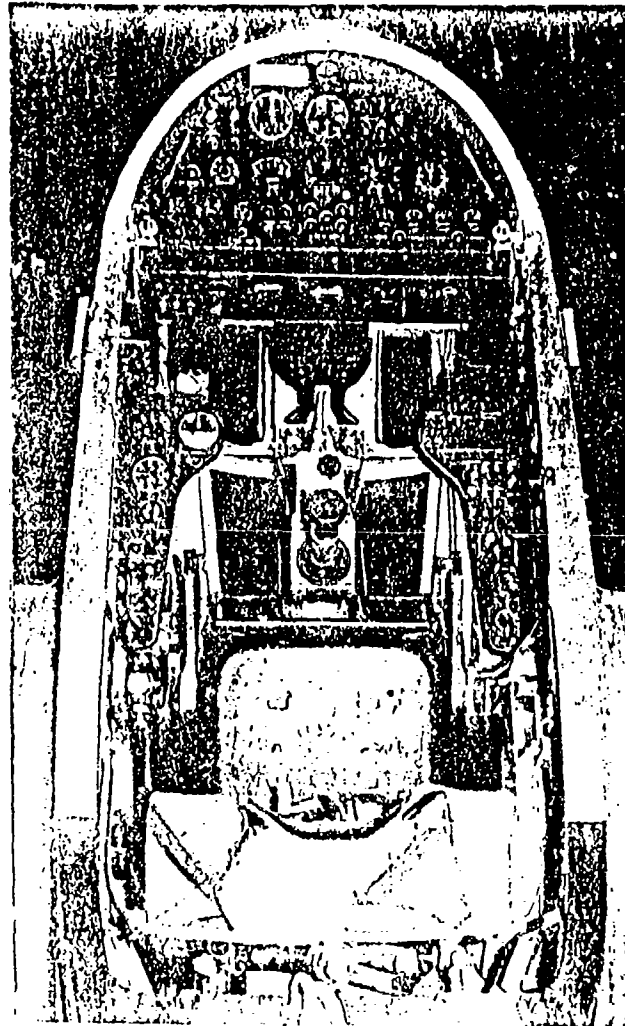

Figure 3.3.3.18 SNECMA C.450.01 Cockpit  
(Courtesy of SNECMA)

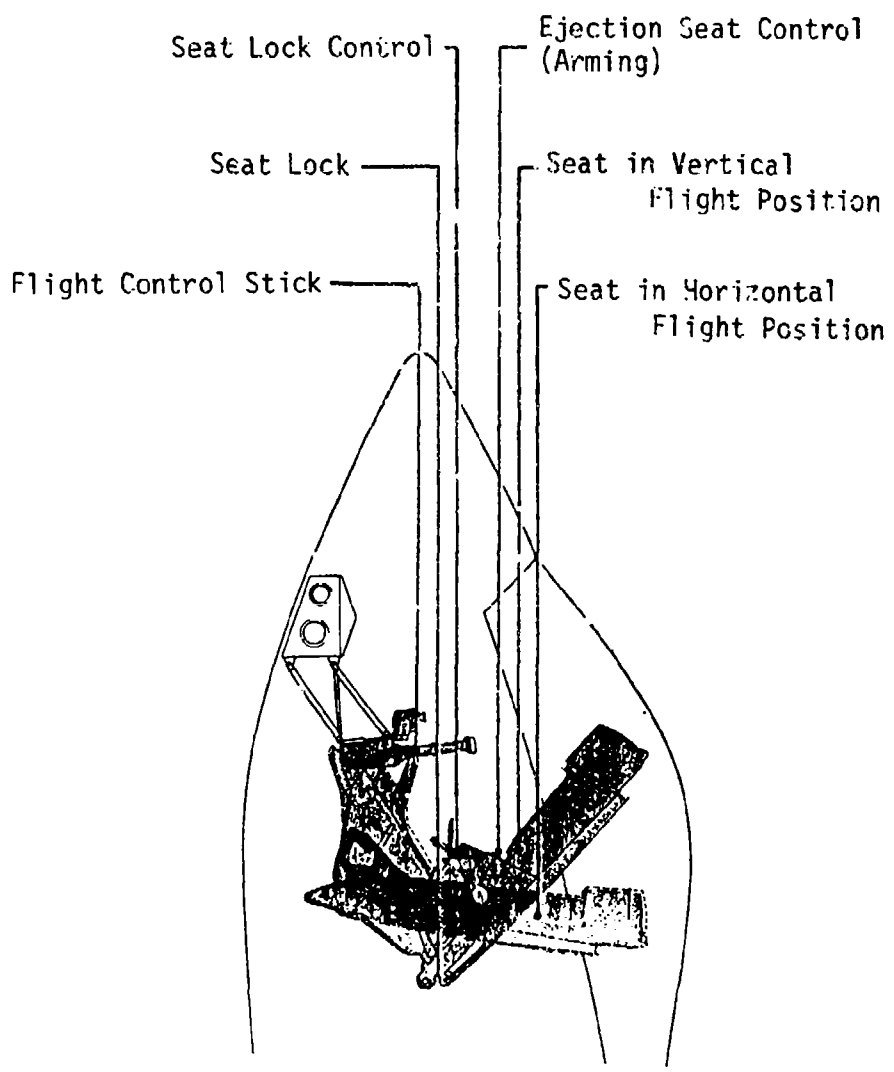

Figure 3.3.3.19 SNECMA C.450.01 Tilting Seat and Controls  
(Courtesy of SNECMA)

the seat could tilt the 55 degrees between its two positions in about four seconds. Although this was done automatically, the pilot could override the automatic system and manually control the position. Ejection could take place in both seat positions with the operation being the same in both cases but the parachute opening sequences (for the seat and the pilot) were different. The pilot could select from either of two ejection sequences: (1) the canopy departs, automatically followed by seat ejection; and (2) the canopy is discarded with the pilot ejecting later at his discretion. Arming of the ejection seat was via a control on the left arm rest and actual firing, including the sequence selection, was by buttons on top of the stick.

Control System: Both the aerodynamic control surfaces and the vertical flight controls (jet deflection and roll reaction controls) were operated by the same control stick. An unique arrangement for that time period, the stick provided pitch and roll control in the conventional manner using longitudinal and lateral angular motions of up to  $\pm 18^\circ$ ; yaw control was by twisting of the cylindrical stick grip which could be rotated  $\pm 45^\circ$ . These motions were linked to the controls (aerodynamic and jet) electrically, an early fly-by-wire system.

Engine thrust was controlled by two throttles, a conventional and a vernier type. This arrangement permitted a more sensitive and precise control of thrust during hover and vertical descent.

SNECMA and their subcontractor, Nord Aviation, were especially concerned with aircraft flight safety from the early stages of design through fabrication. Stringent quality control was exercised during the fabrication of the aircraft components and verification testing was done on the various electrical and hydraulic control elements. The electrical and hydraulic system for controlling and actuating the aerodynamic and reaction controls were duplicated for safety. Failure warning indicators for the flight control system were incorporated into the instrument panel to help the pilot make proper decisions. A fire detection system was installed which monitored abnormal temperatures in the critical areas of the fuselage and alerted the pilot through indicators on the instrument panel.

No information was available regarding the stability and control characteristics of the C.450.01 during transition and conventional mode flight. However, it is known that wind tunnel tests were made on a model to explore transition and conventional mode flight.

It should be noted that both control systems, aerodynamic (tail surfaces) and thrust vector (including

reaction jet roll control) functioned continuously during all flight modes.

The method of using the engine gas flow for pitch, yaw and roll control was described earlier under the "engine" part of this review. Four nozzles were used to provide roll control. These were mounted in sets of two at opposite sides of the ring-wing (Figure 3.3.3.20). The two nozzles of each set pointed in opposite directions to produce opposite rolling moments. Each nozzle had its own air pipe connecting it to the roll air valve located at the engine. There were no control valves at the nozzles.

While the control power and responses of the C.450.01 were not available, it appears that  $\pm 10^\circ$  thrust deflection may have been achievable for pitch and yaw. This is based on SNECMA's earlier development work on a mechanical spoiler type system where this deflection value was used to determine spoiler effectiveness. Figure 3.3.3.21 illustrates the use of thrust deflection for translational flight and control of a hovering VATOL aircraft. From left to right the sequence is: (1) hover, (2) efflux deflection to the right producing clockwise moment about the center of gravity, (3) clockwise rotation of the vehicle and left deflection of efflux to stop rotation, (4) lateral acceleration to the right with vehicle held at a selected angle at constant altitude (vertical thrust vector equal to the weight), (5) left deflection of the jet to create moment for reversing attitude of vehicle, (6) counterclockwise rotation of vehicle and right deflection of the efflux to stop rotation at desired tilt angle, (7) lateral acceleration to the left with vehicle held at selected angle and constant altitude, (8) right deflection of efflux to produce clockwise restoring moment, (9) left deflection of jet to stop rotation with vehicle axis vertical and, finally, (10) hover again.

Obviously, this is an over-simplification of the control process. The jet deflections required must have components at right angles to the plane of vehicle motion to eliminate the gyroscopic moments produced by the rotating mass of the single spool engine (a similar problem existed in the X-13). Further, steady translational flight at constant height would require continuous adjustment of the jet deflection and engine thrust setting due to changes in aerodynamic moments and forces. To make the vehicle flyable SNECMA incorporated a gyroscopically-based control system (auto-pilot) which stabilized the C.450.01. Control signals from the pilot passed through this stabilization system. Figure 3.3.3.20 diagrammatically illustrates this basically fly-by-wire stabilization and control system. It contained the following elements:

1. An attitude gyro for providing pitch and yaw attitude reference (attitude hold).

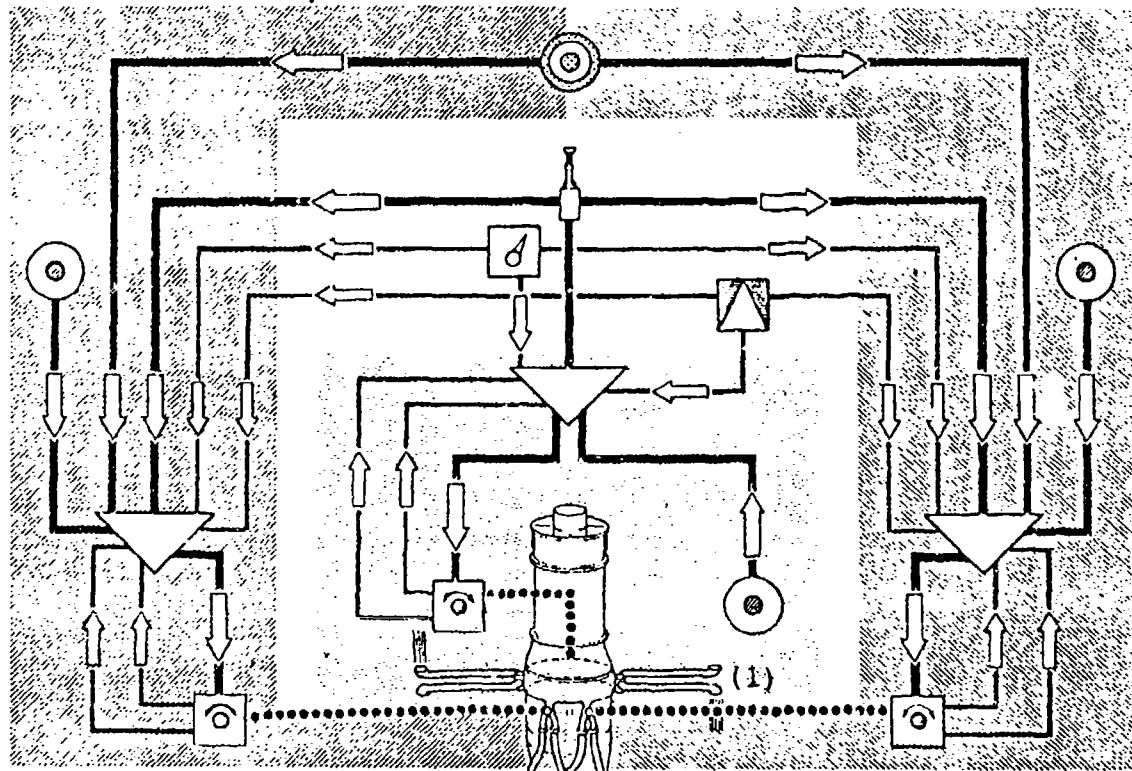

- |                              |                                    |            |
|------------------------------|------------------------------------|------------|
| Control System On-Off Switch | Trim Control                       | Roll Axis  |
| Rate Gyro                    | Magnetic Amplifier                 | Pitch Axis |
| Attitude Gyro                | Electro-Hydraulic Control Actuator | Yaw Axis   |
- (1) Roll Control Nozzles

Figure 3.3.3.20 SNECMA C.450.01 Stabilization and Control System  
 (Courtesy of SNECMA)

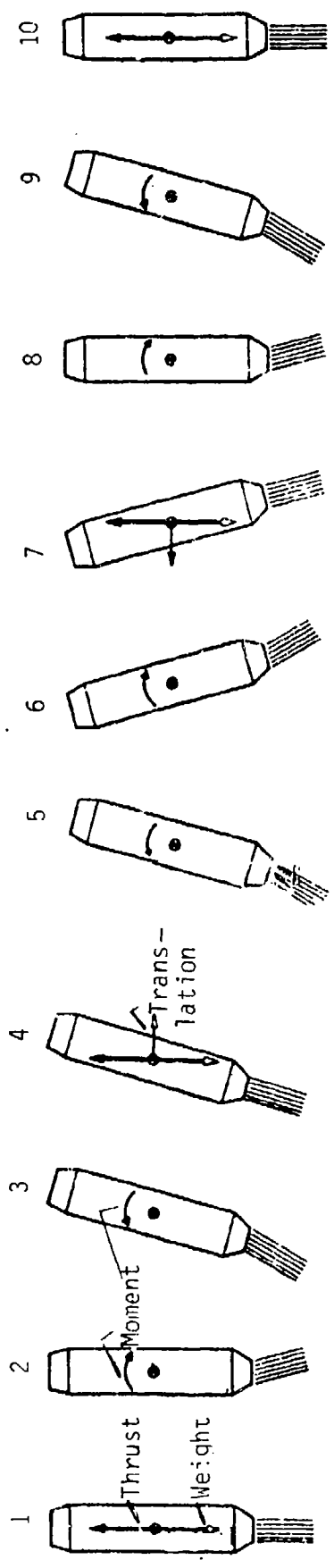

Figure 3.3.3.21 SNECMA Coleopter Translational Motion and Jet Deflection Sequence

2. Three rate gyros to measure rate of angular motion about the pitch, yaw and roll axes to provide rate damping inputs.
3. A pilot's stick for pitch (longitudinal motion), roll (lateral motion) and yaw (twisting motion) inputs to the autopilot system. (There were no rudder pedals.)
4. A switch for turning the electrical system on and off.
5. A trim control unit to permit the pilot to position the stick longitudinally, laterally and twist-wise.
6. A signal processor, integrator and amplifier for each axis to use the signals from the stick, gyros and control actuators.
7. Actuator position information, fed back into the signal integrator.
8. Electrically-controlled hydraulic actuators to operate the air valves regulating the secondary (control) air flow to the engine jet and the flow to the roll control reaction jets (also see Figure 3.3.3.12).
9. An electrical system to produce artificial feel in the control stick.

The pilot was provided with a warning system to alert him to increase thrust (engine rpm) when critical aircraft attitudes were approached during the reconversion process.

Additional information on the stability and control system was not available, but it appears that some of the elements were duplicated in the interest of safety and that malfunction warning indicators were incorporated in the pilot's instrument panel. Information regarding the height control system used was not available except that there were two throttle controls. It is assumed that one provided major thrust changes and the other allowed precise thrust modulation for vertical velocity control.

There is no question that this stabilization and control approach worked properly, the system having been proven during hundreds of hovering flights by the Flying ATARS, C.400 P.1 and P.2.

Performance and Transition Flight: The C.450.01 was an experimental, demonstrator airplane built primarily to prove its capability to perform vertical and conventional mode flight. Hence, it was not designed to fly at supersonic speed; the speed was to be limited to 800 km/hr (500 mph) at sea

level. SNECMA's performance analysis indicated the rate of climb to be 25,600 fpm at sea level and 19,700 fpm at 9,800 ft. Endurance on the 1540 lb of fuel depended on the modes of flight used, being least for an all-hover operation. A duration of 25 minutes was estimated for a flight test involving: VTO, conversion, brief level flight, reconversion and vertical landing.

SNECMA apparently believed that transition from VTO to horizontal flight would pose no problems; the aircraft would be able to accelerate rapidly vertically and tilt over to the angle for adequate aerodynamic lift without difficulty; this angle was given as 30 degrees. SNECMA suggested two methods for transition from conventional to vertical flight, a zoom maneuver and an approximately constant altitude maneuver using a gradual angle of attack change and throttle adjustment. The complete sequence of maneuvers is shown in Figure 3.3.3.22. It is interesting to note the strong similarities between the C.450.01 projected constant altitude conversion behavior and that of the X-13, reviewed in subsection 3.3.2.

Ground Handling: Figure 3.3.3.23 illustrates an earlier SNECMA concept for handling and maintaining a coleopter type airplane. Transportation of the coleopter was in a cradle attached to a flatbed trailer and an erecting system rotated the aircraft to a vertical position for takeoff (details of this system were not available). All maintenance work could be done with the coleopter on the flatbed, including replacement of the forward fuselage and engine using special apparatus.

The actual trailer system built for the C.450.01 is shown in Figure 3.3.3.24a thru e with the aircraft in transport position and in the process of rotation between horizontal and vertical attitudes. (The transparent areas in the belly and sides of the fuselage for improved pilot vision during VTOL flight are evident in c and d of this figure.) The erecting system used places the airplane directly on the ground in takeoff position. Equipment needed to service and maintain the airplane is stored in compartments on the trailer. Figure 3.3.3.25a illustrates the C.450.01 in vertical position with an access platform and protective cover in place. The method for engine replacement (Figure 3.3.3.25b) is indicated also. This trailer had the following principal characteristics:

TABLE 3.3.3.4

SNECMA C.450.01 GROUND HANDLING TRAILER CHARACTERISTICS

Length	29-1/2 ft
Width	11-1/2 ft
Height, empty	8-1/4 ft
Height with airplane in transport position	13-1/4 ft
Weight empty (with support equipment)	15,880 lbs
Weight loaded	22,050 lbs

Zoom Maneuver for Conversion  
from Conventional to  
Vertical Mode Flight

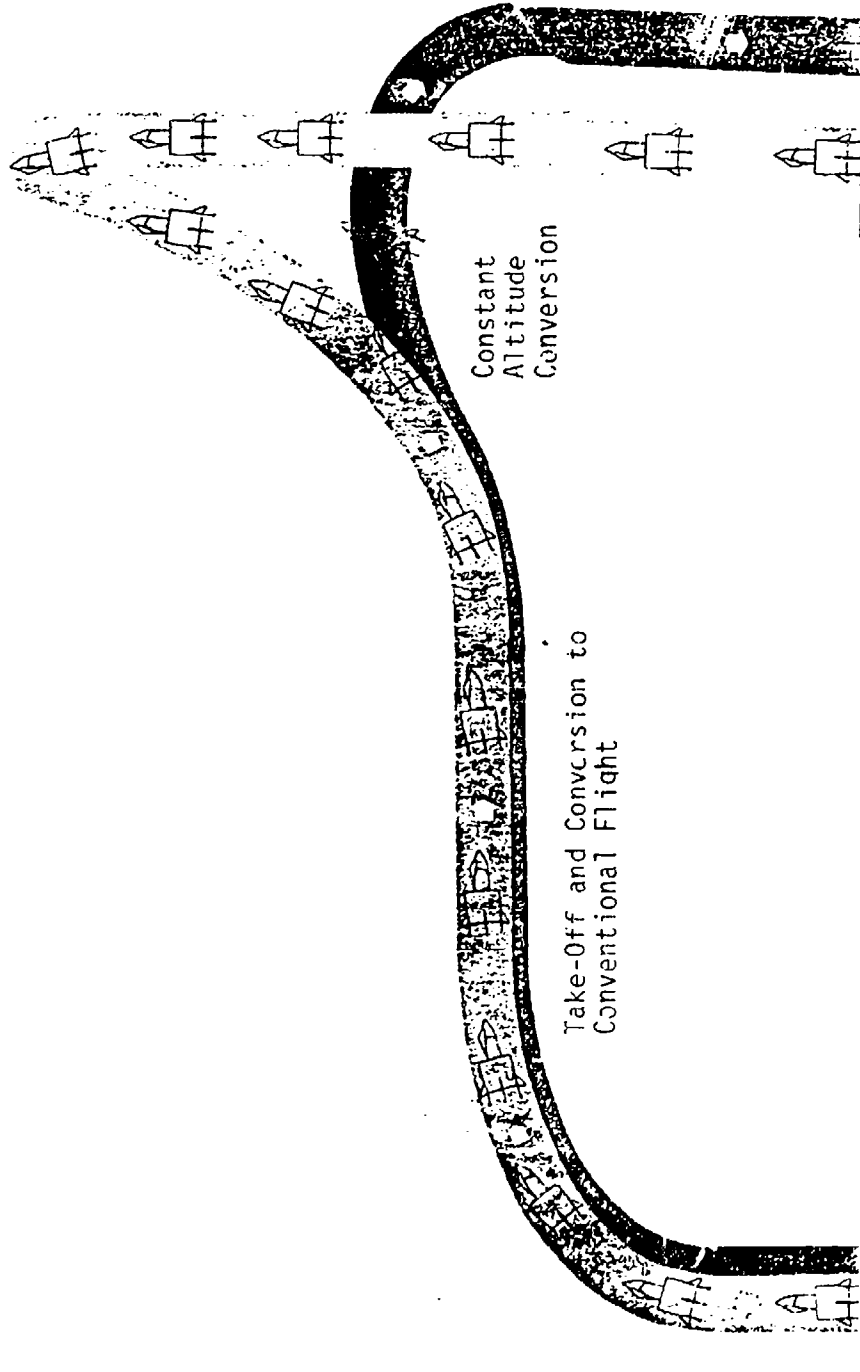

Figure 3.3.3.22 SNECMA C.450.01 VTOL and Transition Flight Maneuvers  
(Courtesy of SNECMA)

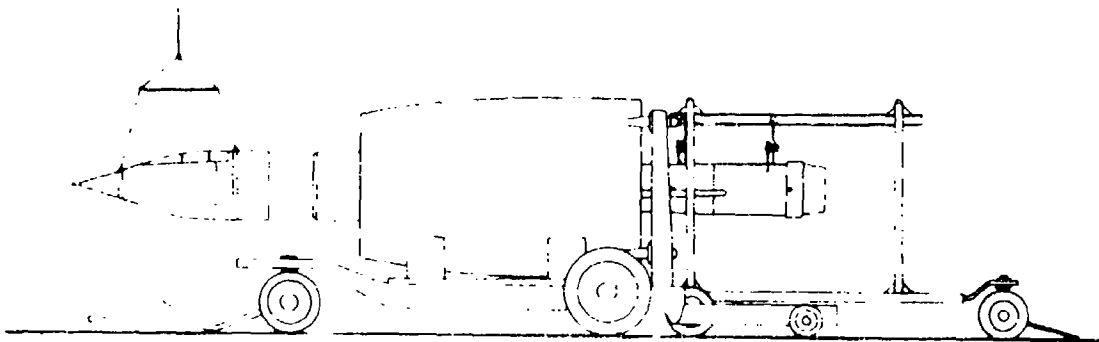
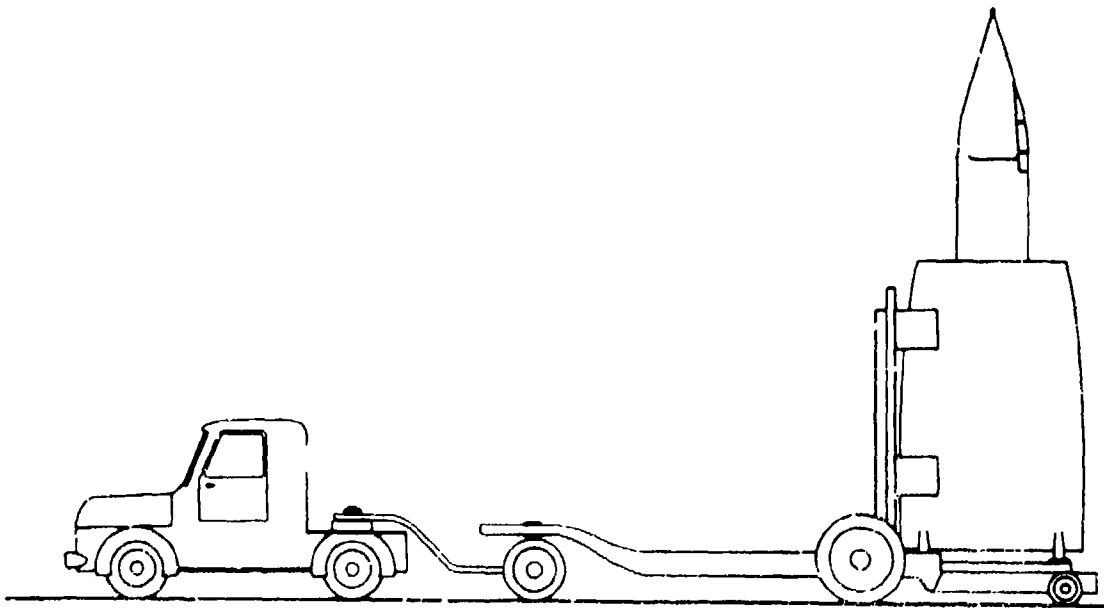
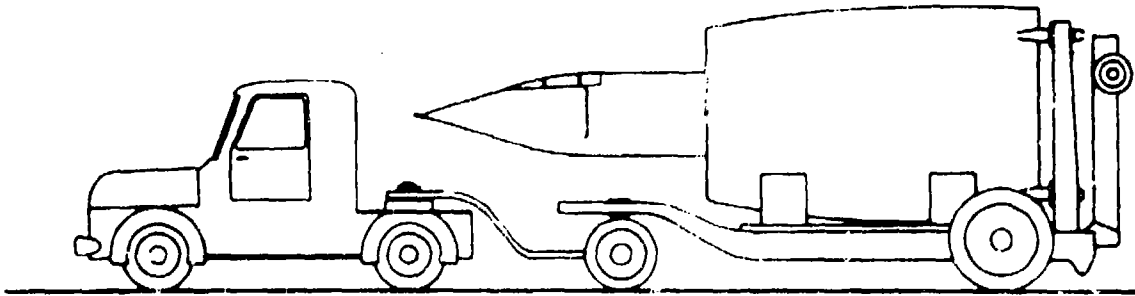
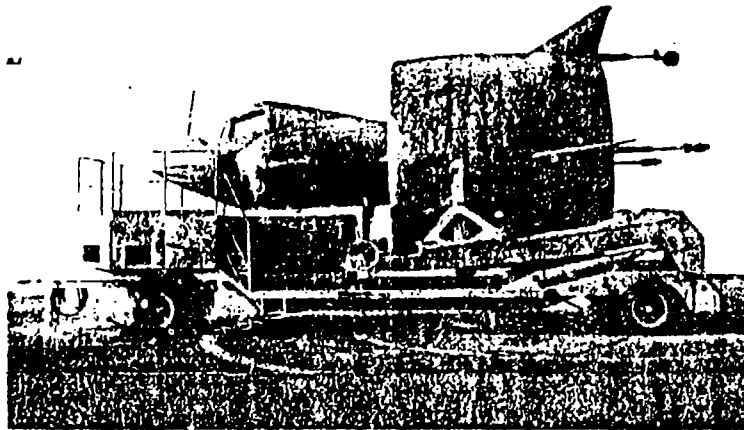
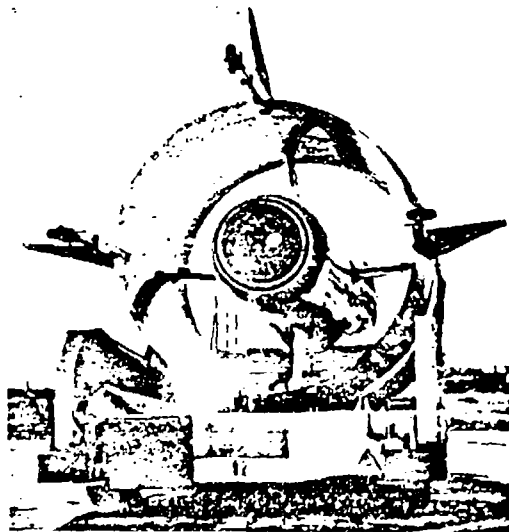

Figure 3.3.3.23 SNECMA Coleopter Ground Handling and Maintenance Concept (Courtesy of SNECMA)



(a) Horizontal Position for Transport, Side View



(b) Rear View

Figure 3.3.3.24 SNECMA C.450.01 on Flatbed Trailer  
and Erecting Process  
(Courtesy of SNECMA)

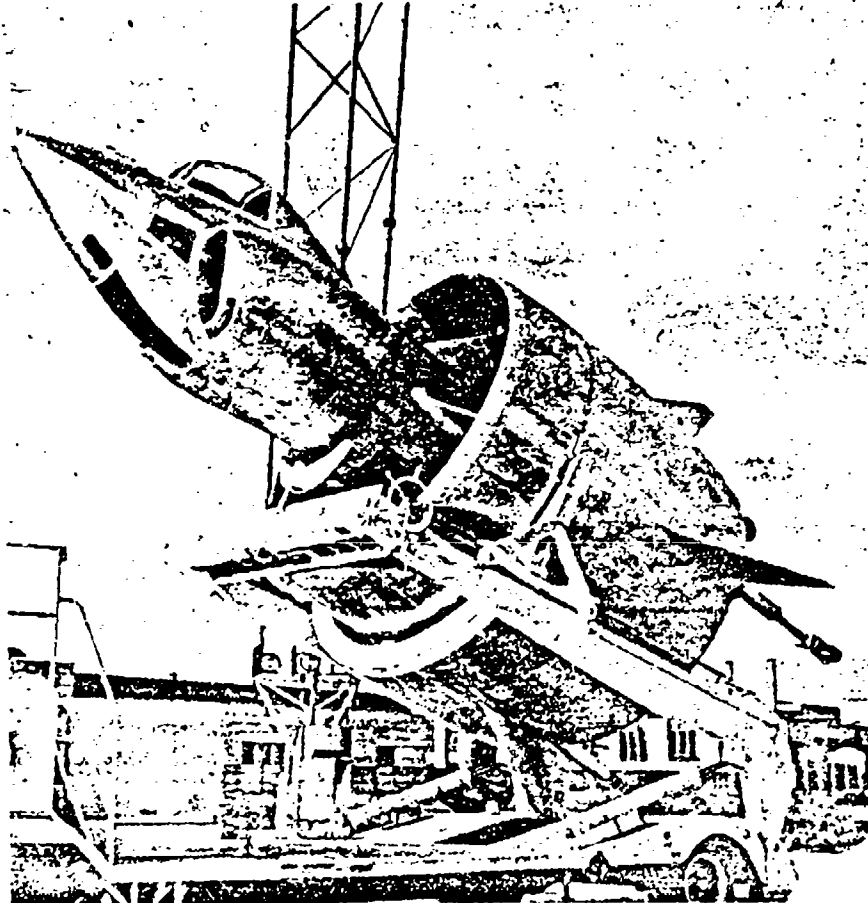

(c) Tilting to Vertical for Setting on Ground

Figure 3.3.3.24 (continued)

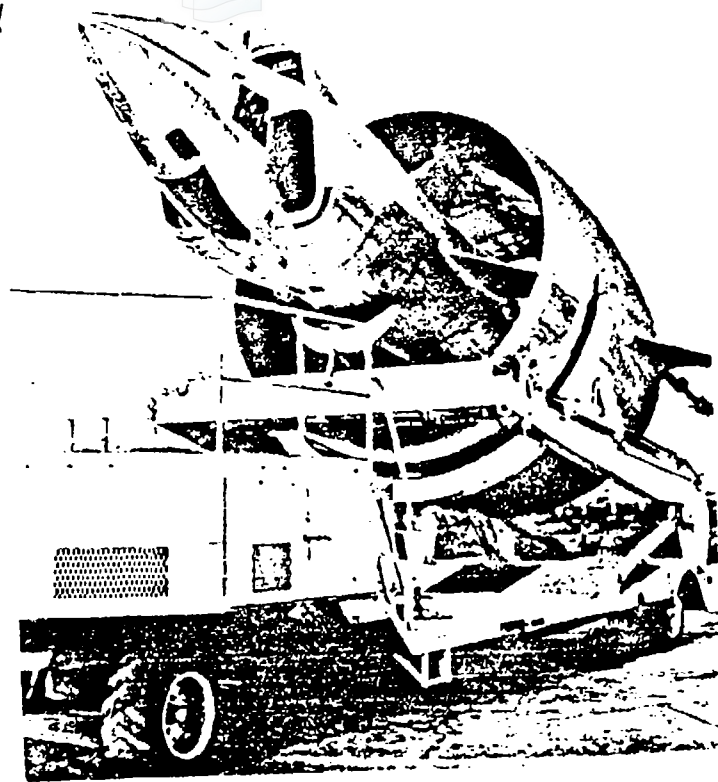

(d) 3/4 Front View Partially Tilted Position

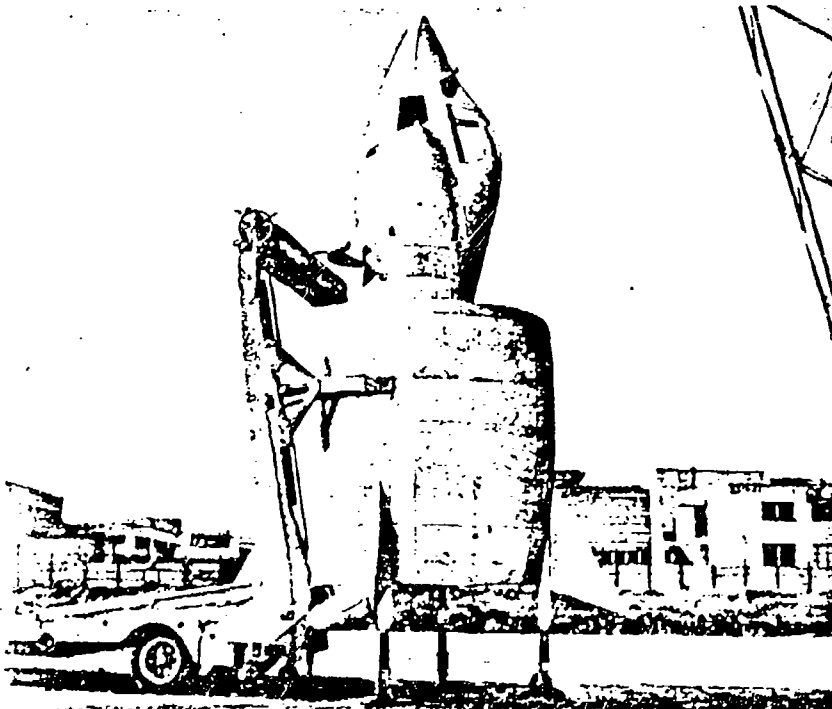

(e) Vertical Position Resting on the Ground

Figure 3.3.3.24 (continued)

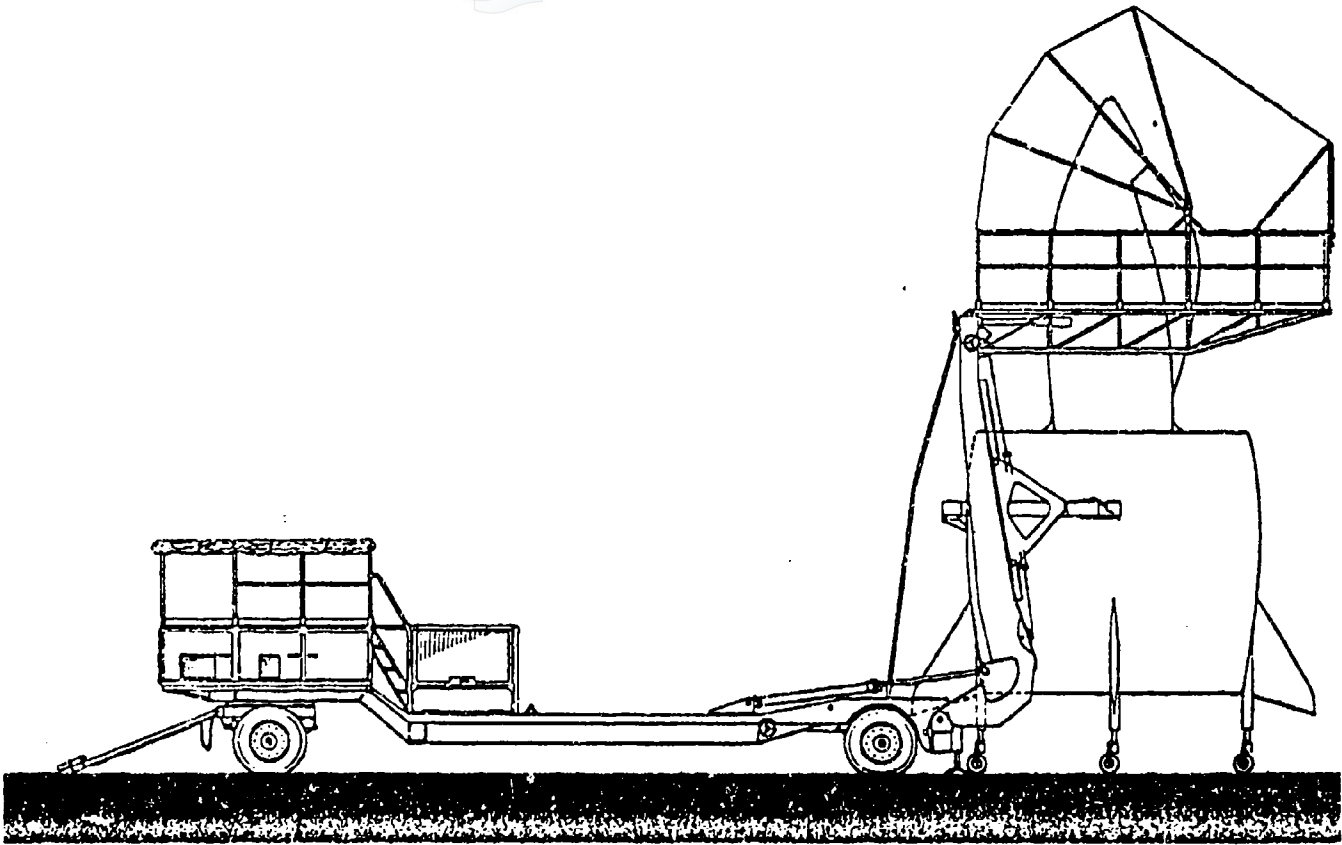

Figure 3.3.3.25a SNECMA C.450.01 with Trailer and Maintenance Shelter--Vertical Position

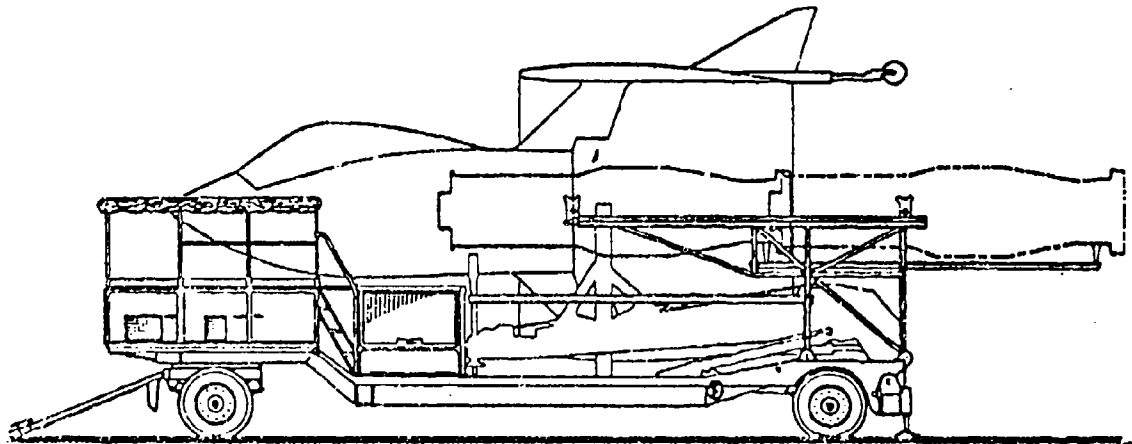

Figure 3.3.3.25b SNECMA C.450.01 Engine Removal on Trailer--Horizontal Position (Courtesy of SNECMA)

Research and Development Work Preceding the

C.450.01: Stability and control of the coleopter was a primary concern particularly during vertical and transition flight and, in 1953, SNECMA undertook research in this area. Among the first efforts was the exploration of the control power required in vertical flight using a model body mounted in a frame arranged to allow free motion in pitch and yaw (Figure 3.3.3.26). An electrically-driven gyroscopic mass was mounted inside the body to simulate engine gyroscopics and weights were attached to the frame to provide airplane inertia effects. Response of this system was explored by applying moments to the frame about the pitch and yaw axes. Other tests were performed on a coleopter model in a low-speed wind tunnel to obtain aerodynamic data during vertical, transition and conventional mode flight.

Based on these efforts, SNECMA made their initial decisions on the control power required in a coleopter. Further exploration and proof of the flyability of their stability and control concept was undertaken using models (Figures 3.3.3.27 and 3.3.3.28) containing the following elements:

- o A 99 lb thrust "Ecrevisse" valveless pulse-jet engine.
- o Electromagnetically-powered spoiler type controls at the pulse-jet nozzle exit to deflect the efflux (thrust vectoring) and act as a throttle system to control the thrust level.
- o Rate gyros to provide damping of the model motions.
- o A remotely operated, on-off ("bang-bang" type) flight control system controlled by the gyroscopic stabilization system and the remotely located human pilot.
- o An electrically-driven gyroscopic mass representing the coleopter turbine engine.
- o Electric lines carrying power and control signals to the model.
- o An open, lattice-type cylindrical structure (Figure 3.3.3.27) representing the mass effects of the ring-wing and providing a base for mounting various elements such as the electrically-driven gyroscope, pulse-jet engine, control system and landing gear.
- o A safety tether to protect the model.

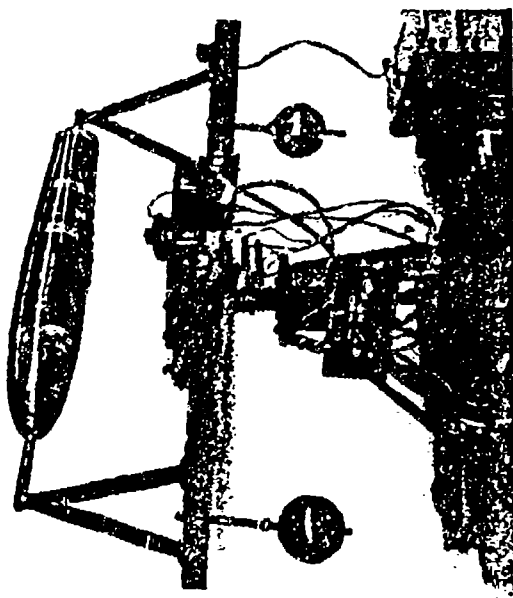

Figure 3.3.3.26 SNECMA Model Test Apparatus for Determining Vertical Flight Control Power

WEIGHT 19.8 lb.  
THRUST 99.2 lb.

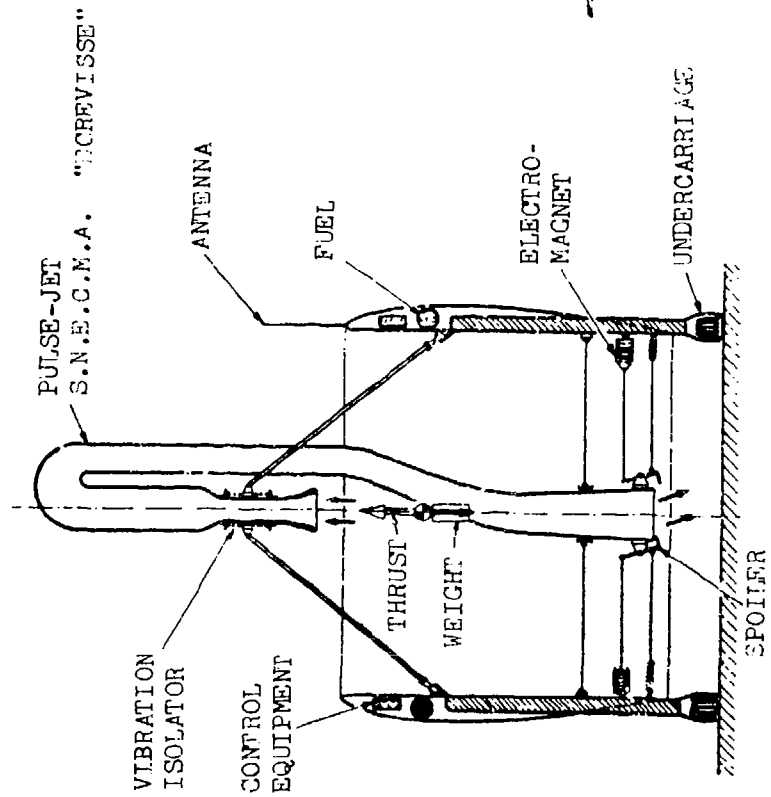
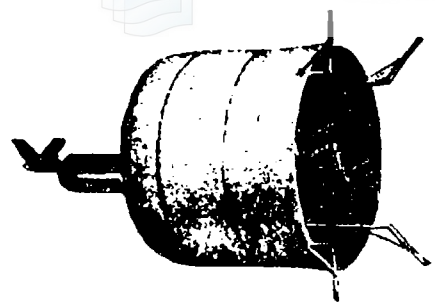

Figure 3.3.3.28 SNECMA Coleopter Pulse-Jet Powered Model with Ring Wing



WIND TUNNEL MODEL

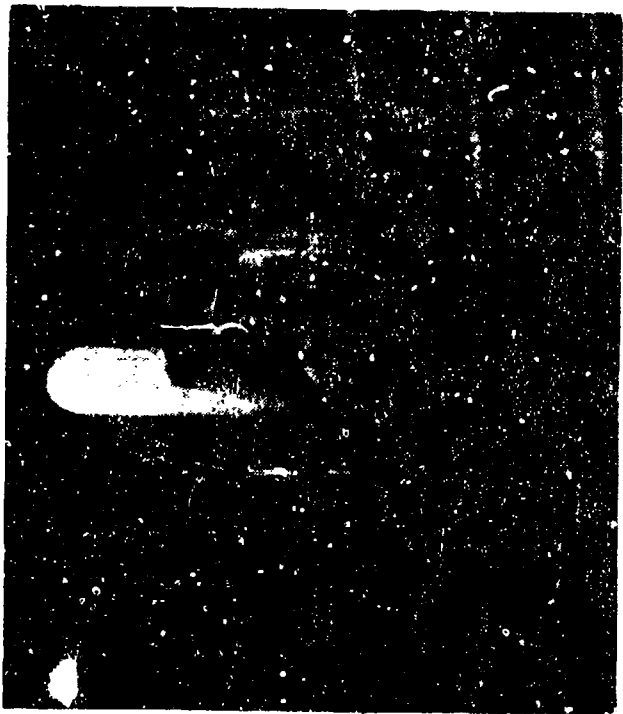

Figure 3.3.3.27 SNECMA Coleopter Pulse-Jet Powered Model in Free Flight (Courtesy of SNECMA)

This model was tested successfully (first flight March 31, 1954) and proved the validity of the stability and control concept. Subsequently, the lattice "wing" was replaced with a light-weight ring-wing (Figure 3.3.3.28) and low speed transitional flights were performed; experience was obtained in the handling of engine gyroscopics and torque effects. It was determined that roll damping via a rate gyro system would be necessary to handle rolling moments created by rapid changes in engine rpm.

Based on the information obtained from the different model tests and the successful free-hovering flight demonstrations of the pulse-jet-powered model, SNECMA decided to proceed with the "ATAR Volant" (Flying ATAR) phase of the development effort in 1955. A number of preparatory investigations were undertaken using an ATAR D engine (6600 lbs thrust). Tests were made to:

1. Determine the effect of the ground on engine operation and on the temperatures in the vicinity of the nozzle and along the ground.
2. Determine the capability of the engine to operate in a vertical attitude for prolonged periods and the changes required in the oil circulation system.
3. Measure the effectiveness of the Flying ATAR thrust vector control system for pitch and yaw control.
4. Determine the effectiveness of the Flying ATAR reaction control system for roll control and of the roll stabilization system.
5. Check the functioning of the stabilization and control system with the Flying ATAR engine free to pitch and yaw  $\pm 15^\circ$ . (A radio remote control system was used in these tests with the controller at a distance from the test rig.)

These and other tests were accomplished using a number of specially built apparatus, some fairly sophisticated. Three of these are shown in Figures 3.3.3.29, 3.3.3.30 and 3.3.3.31.

The ground effect tests were accomplished by mounting the ATAR D engine horizontally on a wheeled platform with the nozzle directed against a large, stationary vertical plate.

A primary concern regarding the operation of the ATAR engines for use in VATOL type aircraft was the lubrication of the bearings in sustained vertical operation, since the engines' lubrication system had been designed for horizontal operation. To determine the changes required the ATAR D was placed vertically in a special rig. In this set-up, the engine efflux flowed downward into ducts which turned the flow horizontally and directed it away from the rig.

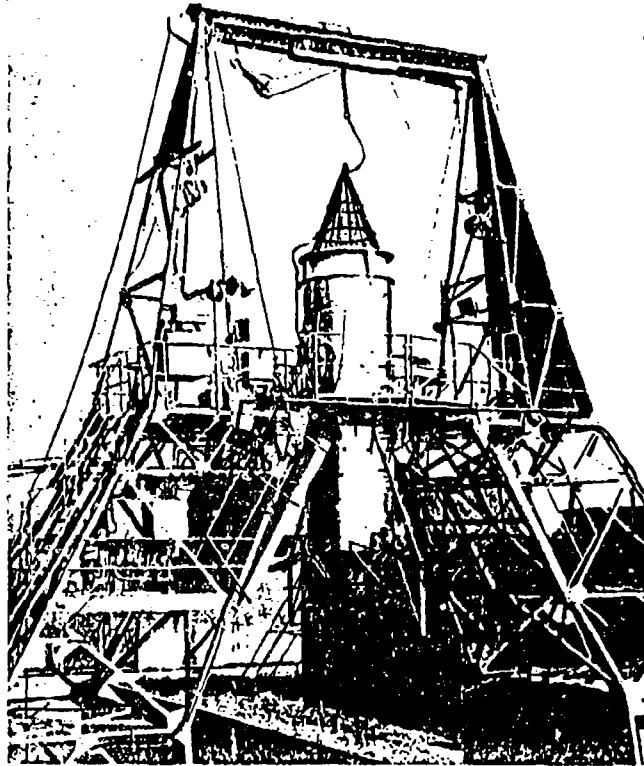

Figure 3.3.3.29 C.400P.1 In Test Rig to Check Control and Stabilization Systems

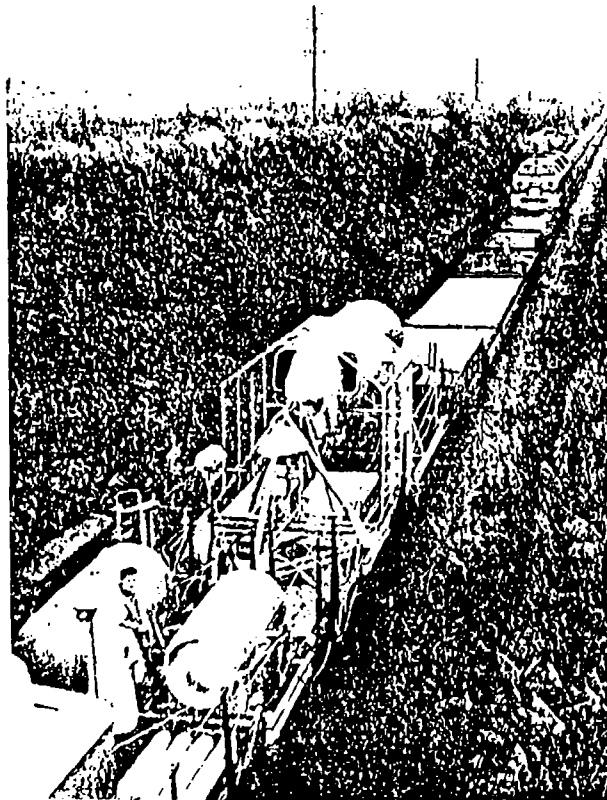

Figure 3.3.3.30 SNECMA C.400 P.3 Test Apparatus  
Simulated Vertical Descent Test  
(Courtesy of SNECMA)

Modification of the ATAR D for vertical flight (making it into an ATAR D V) and for subsequent use in the Flying ATAR testbed efforts involved, not only changes in the lubrication system but, as discussed earlier, the addition of thrust vector and reaction type roll control systems. Tests of the modified engine were made in a special rig arranged to measure the effectiveness of the fluidic control system in deflecting the engine efflux and to determine the actual control moment-control deflection relationship.

Determination of the effectiveness of the bleed air reaction roll control system was done in another special rig. This test sequence was used to determine, first, the roll control power available and then to check the roll stabilization system by imposing rolling motions on the engine and measuring the stabilized roll response.

Following completion of the static (fixed attitude) tests on the pitch and yaw control system, the ATAR D V was set up horizontally in a rig (Figure 3.3.3.31-Oscillation Test Rig) which allowed the engine freedom to pitch and yaw  $\pm 15^\circ$  ( $30^\circ$  cone). During the tests pitch and yaw control were remotely commanded from a distance to check out the complete control system in preparation for free flight tests of the first Flying ATAR, the C.400 P.1. The ATAR D V engine incorporated the stabilization system used in the C.400 P.1 and the results of the oscillation bench tests proved the stability and control system to be satisfactory.

The development efforts on the ATAR D V engine were completed in 1955 and in that same year the engine was used in the construction of the radio-controlled, remotely-piloted Flying ATAR, C.400 P.1 testbed. Figure 3.3.3.32 shows the C.400 P.1 and also identifies its major elements. The C.400 P.1 led to the piloted version designated C.400 P.2. Both flight vehicles are shown together in Figure 3.3.3.4. Prior to its first flight, the C.400 P.1 was mounted vertically in a rig which SNECMA called the "gyroscopic test bench" (seen in Figure 3.3.3.29) arranged to permit free pitch, yaw and roll motions (within limits). Flight simulation testing was done in this rig to check the effectiveness of the complete stabilization system operating simultaneously on all three axes of motion; to obtain experience with the flight control of the vehicle; and to make sure that the radio control transmitter and receiver were functioning properly. The C.400 P.1 was artificially perturbed to check the functioning of the stabilization system. These tests were a prelude to the free flight testing under the safety gantry (Figure 3.3.3.33).

The specially built safety gantry was 115 feet high. A cable from the top kept the testbed from crashing should an engine shutdown be required or a thrust loss occur.

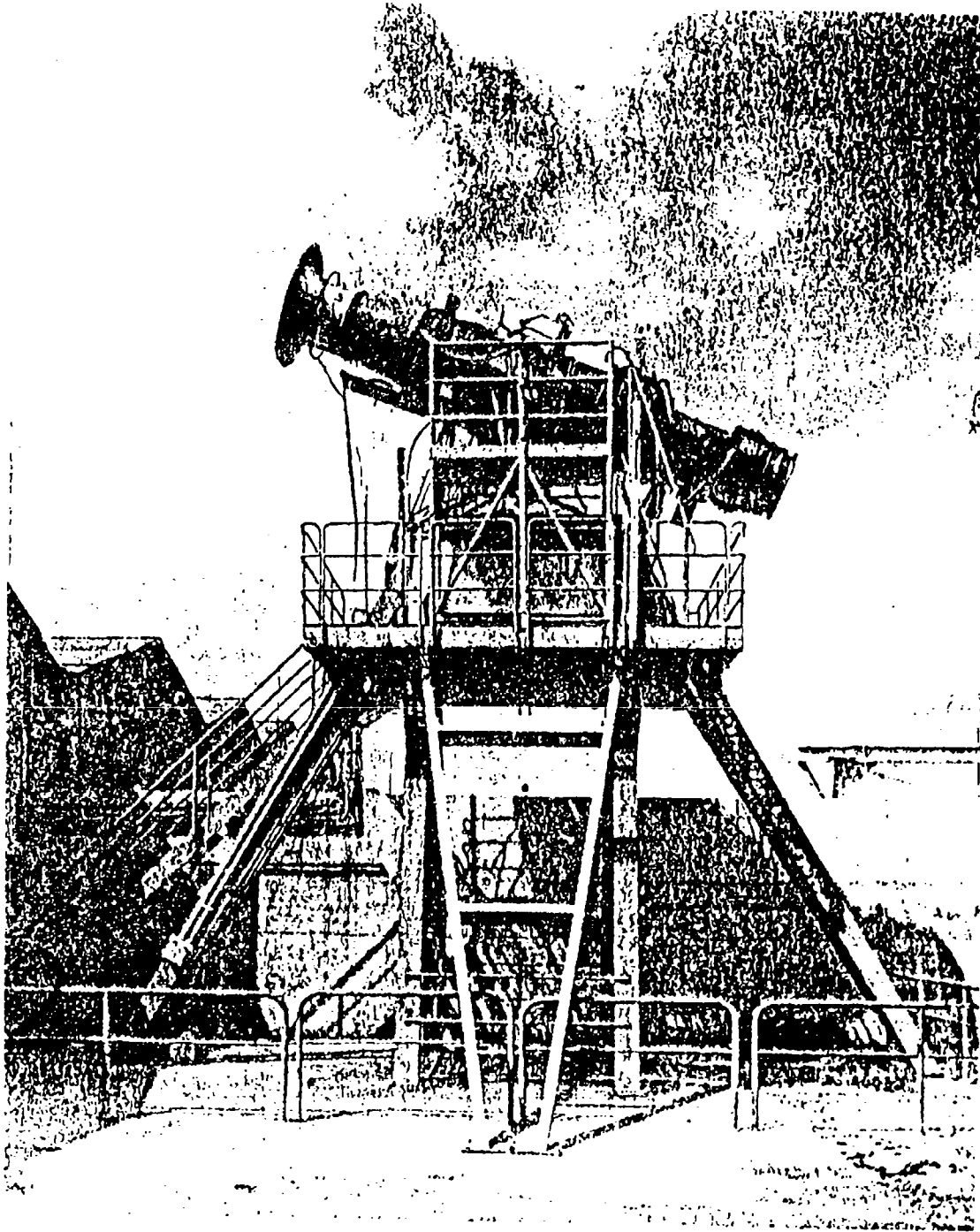

Figure 3.3.3.31 SNECMA Oscillation Test Rig  
(Courtesy of SNECMA)

Engine: ATAR D V  
Thrust: 6400 lb (Approx.)  
Test Bed Wt: 5500 lb (Approx.)

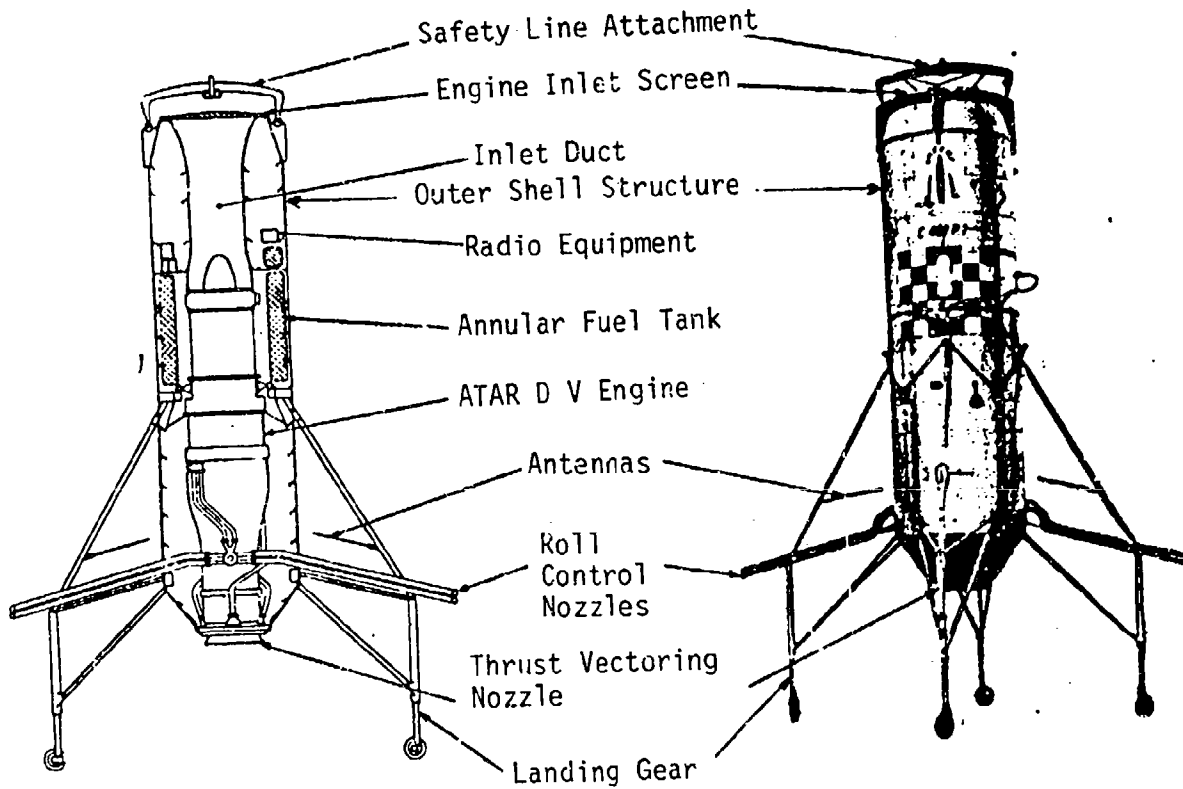

Figure 3.3.3.32 SNECMA C.40 P.1 Radio Controlled Flying Testbed (Flying ATAR)  
(Courtesy of SNECMA)

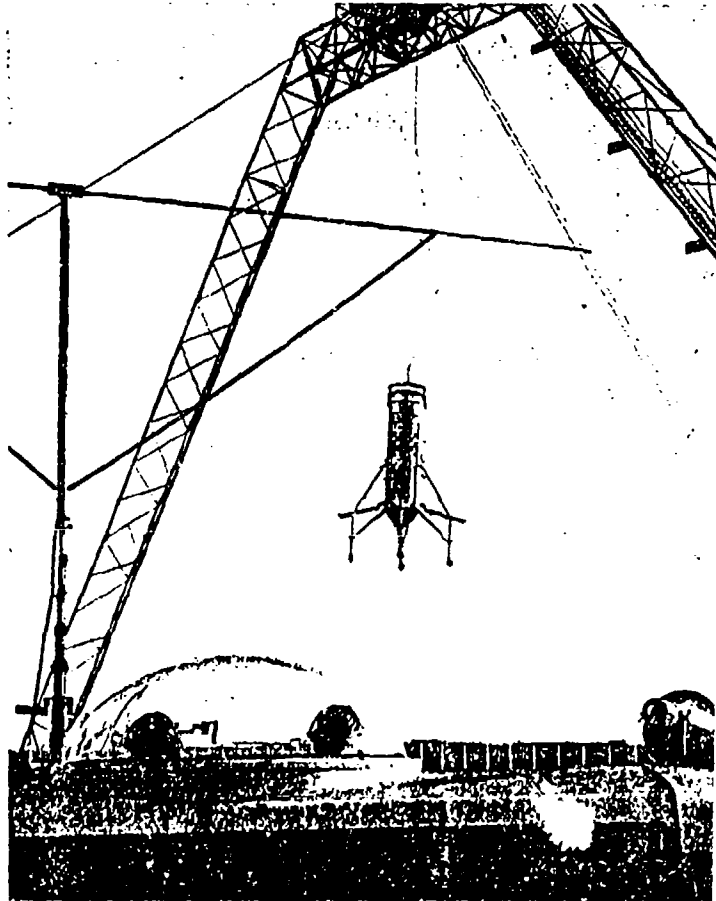

Figure 3.3.3.33 SNECMA C.400 P.1 Testbed Hovering  
Under Safety Gantry  
(Courtesy of SNECMA)

Lateral cables from the sides limited the horizontal movement resulting from any unexpected response. All of the cables were slackened to permit free hover flight and limited translations. A shelter with a glass dome, seen in the foreground of Figure 3.3.3.33, was provided for the radio-control pilot and observers. A long and very satisfactory series of flights were made by the C.400 P.1 under the gantry.

The C.400 P.1 had a flight weight of about 5500 lbs and an available thrust of approximately 6400 lbs giving the vehicle a thrust/weight of 1.16.

Confidence in the Flying ATAR system having been well-established by the radio-controlled C.400 P.1, SNECMA completed the man-carrying testbed, C.400 P.2 (Figure 3.3.3.34). This placed a pilot on the Flying ATAR in an ejection seat mounted above the engine air intake and put him in direct manual control of the vehicle. Otherwise, the vehicle was virtually identical with the radio-controlled C.400 P.1. Both used an ATAR D V engine.

Flight weight of the C.400 P.2 was about 5730 lbs (230 lb heavier than its predecessor); engine thrust remained approximately 6400 lbs resulting in a thrust/weight of 1.12.

Initially, this testbed was flown under the gantry and the flights were considered to be very satisfactory. On May 14, 1957 the first completely free flights outside of the safety gantry were made. Subsequently, on June 1-2, 1957 the C.400 P.2 was publicly demonstrated at the Paris Air Show at Le Bourget. Figure 3.3.3.35 shows the vehicle in completely free vertical flight.

A third "Flying Engine" testbed designated C.400 P.3 was built to provide the pilot with the actual cockpit environment of the C.450.01 aircraft and to explore transition problems. This testbed was equipped with a cockpit, tilting seat, forward fuselage and side air inlets similar to that planned for the C.450.01 aircraft.

SNECMA was concerned that the engine thrust might be affected during vertical descent if appreciable sink speeds were reached. It was theorized that the flow into the engine air inlets might be adversely affected under such conditions. To resolve this, the C.400 P.3 was installed on a railroad train composed of flatcars and a diesel-electric locomotive, with the C.400 P.3 mounted tail facing into the direction of motion. Figure 3.3.3.30 shows the C.400 P.3 mounted on the train. Five flatcars were interposed between the locomotive and the C.400 P.3 to reduce the effect of the locomotive's aerodynamic disturbances. Behind the C.400 P.3 flatcar, additional cars carried support (fuel etc.) and data gathering equipment. Various speeds, up to 45 mph (3940 ft/min sink speed) were run. There was little effect on the thrust.

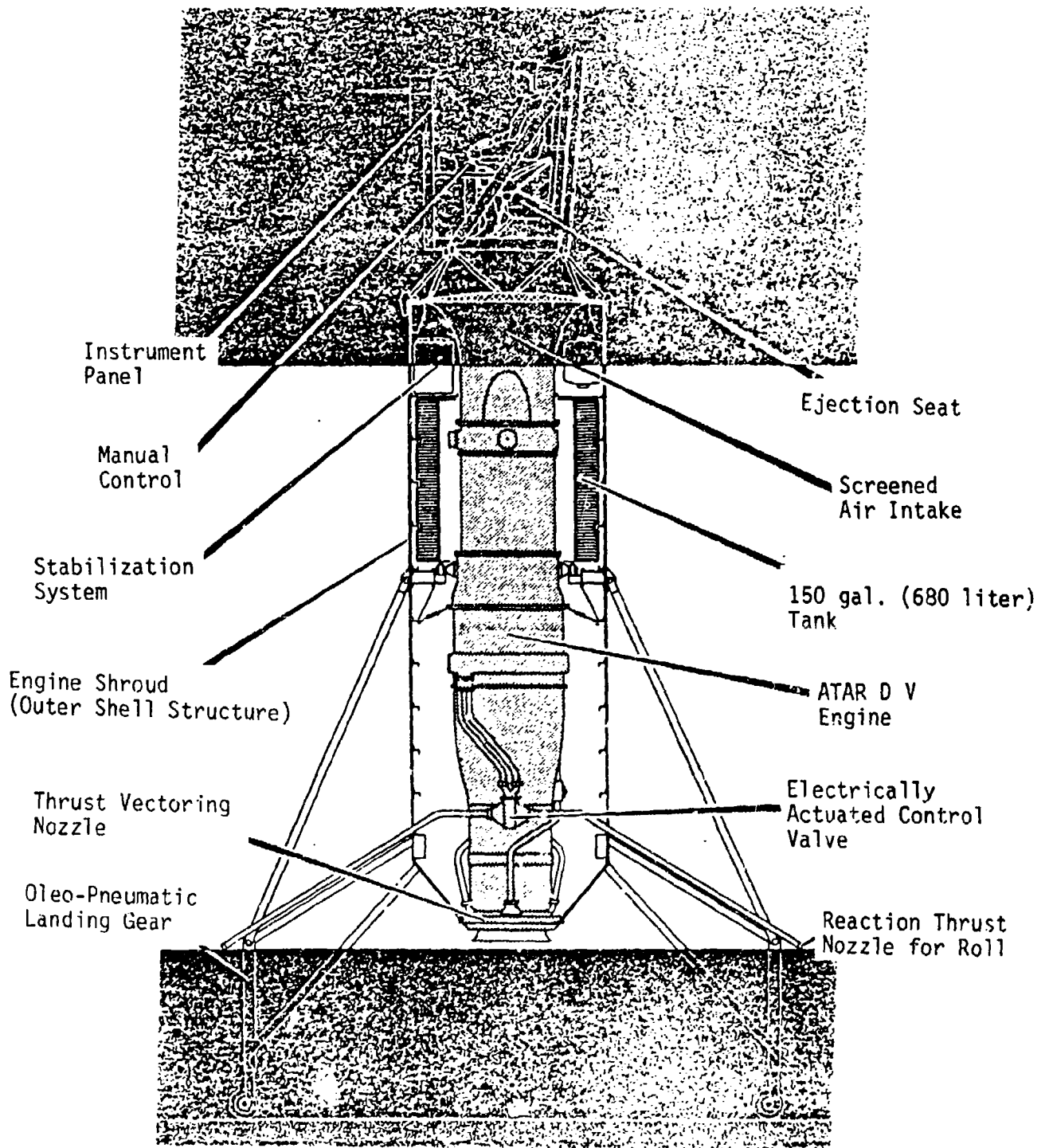

Figure 3.3.3.34 Components of SNECMA (ATAR Volant)  
C.400 P.2 (Courtesy of SNECMA)

Pilot

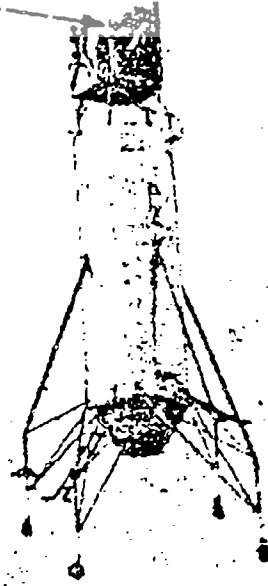

Figure 3.3.3.35 SNECMA C.400 P.2 In Free Hovering Flight  
(Courtesy of SNECMA)

The C.450 P.3 was installed in the "gyroscopic test bench" (Figure 3.3.3.31) to permit the pilot to experience transition attitudes ranging from vertical to horizontal and to determine the external vision panoramically.

Aerodynamic Testing: Testing of aerodynamic models was done in wind tunnels at both low and supersonic speeds. The low speed tests covered the various flight modes from vertical through transition to conventional attitude. No data were made available on the results of these tests.

Concluding Observations: Although the coleopter concept now is over 30 years old it continues to be interesting, particularly as a basis for supersonic VTOL aircraft. This interest arises from the concept's potentials in: combining ramjet propulsion with a propulsive ring-wing, light weight airframe structure, VTOL aircraft simplicity and, for fighters, exploitation of the turning without banking maneuver capability. It is unfortunate that the C.450.01 airplane was lost before it could complete the planned flight testing since this left the concept's validity unresolved. It is probable that a successful demonstration of VTOL, transition and conventional flight would have led to the subsequent development stages of ramjet propulsion and supersonic operation.

Based on the work done during the coleopter development the following are specifically noteworthy:

1. The extensive and well-planned nature of the SNECMA program, the effective testing techniques used and the unique testing facilities developed.
2. Hundreds of successful hovering flights had been accumulated by the Flying ATARS and the C.450.01 airplane before its loss. Hence, the loss does not appear to be due to any basically unacceptable characteristic of the aircraft in vertical flight.
3. The fluidic system for vectoring the jet thrust was an unique approach and proved effective for vertical flight control.
4. The vertical flight stabilization and control system was successful and was based entirely on the fly-by-wire approach. This is a particularly noteworthy accomplishment considering the time period.
5. Without SNECMA's release of test and analysis information, assessment of the critical elements of the coleopter concept cannot be made. The critical elements are:
  - Stability and control behavior in transition and conventional mode subsonic flight.
  - Supersonic aerodynamic characteristics.

- Ramjet operation, particularly with respect to low pressure/high altitude/low temperature combustion.
- Achievement of the predicted reduction in structural weight.

REFERENCES - SECTION 3.3.3

- 3.3.3.1 Plaskowski, Z., "Report on Annular Wings," Fourth International Astronautical Congress, Zurich, Aug. 5, 1953.
- 3.3.3.2 Von Zborowski, Helmut, "The Coleopter - A Formula for Economy," Interavia, Jan. 1955.
- 3.3.3.3 Oestrich, Hermann, "S.N.E.C.M.A. and the Coleopter," Interavia, Jan. 1955.
- 3.3.3.4 Seibold, Wilhelm, "The Mechanics of Flow on Annular Wings," Interavia, Jan. 1955.
- 3.3.3.5 Hertel, Heinrich, "Structural Principles of the Coleopter Wing," Interavia, Jan. 1955.
- 3.3.3.6 Haber, F., "A Study of the Coleopter Principle and Its Application to Supersonic Flight," Project No. 160.0, Lycoming Gas Turbine Department Report No. 160.1, Apr. 6, 1955.
- 3.3.3.7 "The Coleopter," Aero Digest, June 1955.
- 3.3.3.8 Weyl, A. R., "Coleopter Combines Wing and Power-plant," Aviation Age, Nov. 1955.
- 3.3.3.9 Kirchner, Englebert, "SNECMA Tackles Low Speed Coleopter Control," Aviation Age, Nov. 1956.
- 3.3.3.10 Rauscher, Manfred, "Aeroelastic Studies of Annular Wings," Kaman Aircraft Corporation Report No. R-201, July 25, 1957.
- 3.3.3.11 "C.450 Coleoptere", SNECMA Brochure, 1958 (estimated).
- 3.3.3.12 SNECMA Brochure on history of the Coleopter development, 1958 (estimated).
- 3.3.3.13 Janes All the World's Aircraft, 1959-1960.

3.3.4 U.S. Navy David Taylor Naval Ship Research and Development Center (DTNSRDC) VATOL Remotely Piloted Vehicle, XBQM-108A (1973-1977)

The third VATOL airplane to be built was a small, 560 lb machine designed for use as a remotely piloted vehicle (RPV). This aircraft was given the designation XBQM-108A by the Department of Defense. The project was initiated and carried out by the DTNSRDC and had two purposes: (1) to establish the validity of the VATOL concept for RPV operations from moving ships, and (2) to explore the problems faced by the ship-based manned VATOL aircraft systems. The original plan was for the DTNSRDC to develop the VATOL RPV and fly it from the side of a moving ship, demonstrating vertical take-off, vertical landing (docking), conversion and conventional mode flight. The project was begun in 1973 and the first tethered hover was accomplished on September 29, 1976. Subsequently, the remainder of the test program was deferred because of funding priorities and the Navy's reduction in interest in RPV's at that time. As of September 1977 a total of \$1.5 million has been spent by the Navy on the XBQM-108A effort.

The XBQM-108A project grew out of the Navy's interest in RPV's and their potential for use in various missions such as reconnaissance, target designation, close-in jamming and surface attack. Navy analysis had indicated that the RPV's could be as much as 60 percent lighter and cost as little as one-third that of comparable manned aircraft intended for similar missions. However, the RPV's were not viewed as replacements for manned aircraft but as complements to help improve the total effectiveness of naval air support. For obvious reasons, the RPV's appeared to be especially attractive for use against heavily defended targets, this attractiveness being enhanced by their potential for operation from a variety of small, non-aviation ships as well as aviation types. Among the problems associated with RPV's are launch and recovery, particularly the latter.

During 1973, the DTNSRDC investigated RPV launch and recovery and concluded that VATOL offered several unique advantages:

- Ability to dock at the ship's edge against a vertical platform thereby reducing deck space requirements.
- Placement of engine exhaust overboard eliminating problems associated with jet blast on the deck and its effect on the crew.
- Reduced hazard to the ship and personnel. During a landing, a sudden loss of thrust would cause the RPV to crash into the water and not on the ship's deck.

- Simplicity of VATOL RPV design compared to other VTOL approaches, particularly from a propulsion system development standpoint. Existing engines could be readily adapted to a VATOL RPV.

The actual demonstration airplane development effort was initiated in March 1973 and the configuration selected was based on the Ryan X-13 because of that vehicle's well-known success. To reduce development cost, it was decided to design and develop an aircraft of less than 600 lb gross weight since this could make use of existing Navy missile and target drone hardware. A 600 lb vehicle could be handled by four men but was believed to be large enough to permit useful flight testing of vertical attitude docking on a ship under way. Such testing would permit assessment of the landing and take-off problems under the actual air turbulence conditions created by the ship's superstructure and, also, the problems of operation on a pitching, rolling and heaving ship.

Independent Exploratory Development funds were allocated for the program (\$280,000 in FY 1974 and \$300,000 in FY 1975). Essentially, the effort was done in-house by the NSRDC in association with other Navy organizations and with subcontract help where necessary, such as from Teledyne CAE on the engine.

General Description of the Airplane: The design of the airplane was based on the use of existing components, where feasible. During the initial sizing and design effort, the available Teledyne CAE XJ402 engine was selected. This had been used during the design phase of the Harpoon missile. Its 660 lb static thrust and engine-mounted direct current alternator made it a logical choice for the demonstration airplane; the alternator was needed to supply electrical power during flight. The other existing components selected were:

- A nose cone and forward fuel tank structure from a MQM-74A target drone; used for the forward fuselage.
- A tricycle landing gear from a Bede-5J airplane, attached to the XBQM-108A airframe in permanently extended position.
- A MQM-74A recovery parachute for emergency recovery.
- A Harpoon (AGM-84A) midcourse guidance unit (MGU) built by IBM.
- A Harpoon radar altimeter.

- o A Harpoon signal conditioner and telemetry tray.
- o MQM-74A command and control equipment.

Figure 3.3.4.1 shows the completed XBQM-108A in conventional take-off and landing attitude and Figure 3.3.4.2 is the general arrangement drawing of the airplane. Unlike the Ryan X-13, this VTOL RPV employed a close-coupled canard and main wing configuration with both surfaces using clipped delta wing planforms. The configuration is similar to the Vought Superfly SF-121 discussed in Section 3.3.5.

A well-streamlined fuselage housed the engine, fuel system, avionics equipment, control system and recovery and drag parachutes. Mounted on top of the aft fuselage was a single conventional vertical tail with a rudder having  $\pm 30^\circ$  travel. The main wing was attached at the fuselage bottom and the engine air inlet was located between the wing leading edge and fuselage proper. Close to and slightly above the main wing was the canard surface, attached to the fuselage at a fixed, positive  $5^\circ$  incidence angle; this surface was not used for control. Longitudinal and lateral control in aerodynamic flight were provided entirely by the elevons on the main wing trailing edge. These could move from  $+10^\circ$  to  $-40^\circ$  (trailing edge up).

The engine was mounted in the rear fuselage. Aft of the engine tailpipe, in the efflux, was a set of cruciform thrust vectoring vanes which provided pitch, yaw and roll control in subaerodynamic flight. Wing tip reaction jets similar to those in the X-13 were not used.

The main (rear) struts of the tricycle landing gear were attached to the wing lower surface and braced in tripod fashion, while the nose gear extended from the fuselage at a position just ahead of the canard leading edge. Welded to the nose gear strut was a simple hook for use during VATOL operation.

Table 3.3.4.1 summarizes the significant characteristics of the XBQM-108A. Additional information can be found in References 3.3.4.1 and 3.3.4.2.

Figure 3.3.4.3 gives the lift and drag characteristics of the XBQM-108A as obtained from tests in the DTNSRDC 8'x10' subsonic wind tunnel of a 30% scale model representative of the airplane in an operational RPV configuration (no landing gear). These tests were run at 153 mph (69 psf dynamic pressure). The best L/D is about 6.5 and occurs at a  $C_L$  of 0.35. The zero lift drag coefficient is approximately 0.02. The drag of the exposed landing gear ( $C_D = 0.05$ ) is about 2-1/2

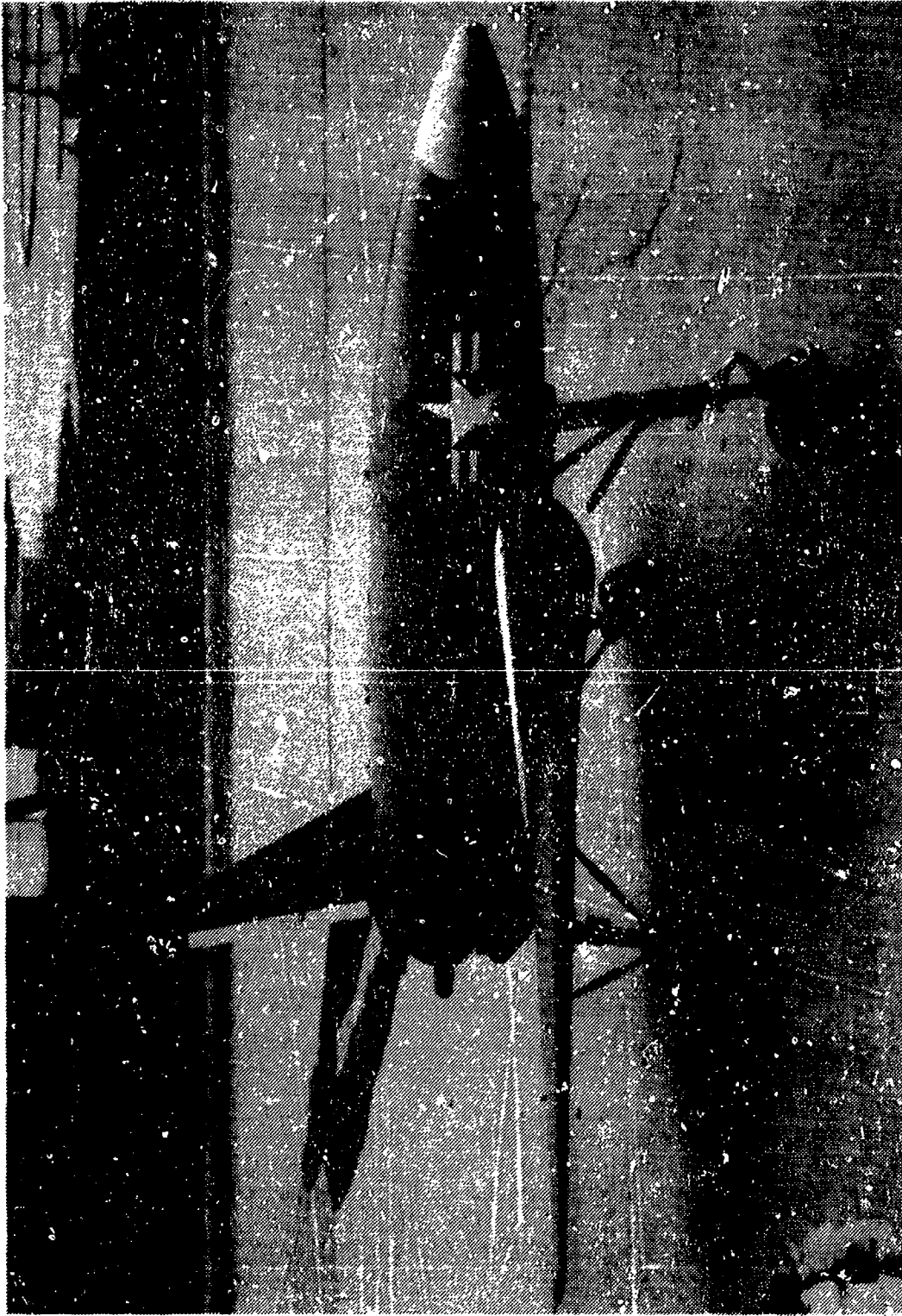

Figure 3.3.4.1 DTNSRDC XBQM-108A VATOL Remotely Piloted Vehicle in CTOL Position  
(Courtesy U.S. Navy, DTNSRDC)

Wing Area Total 26.8 sq ft (2.49 kg/m<sup>2</sup>)  
Airfoil NACA 64A008

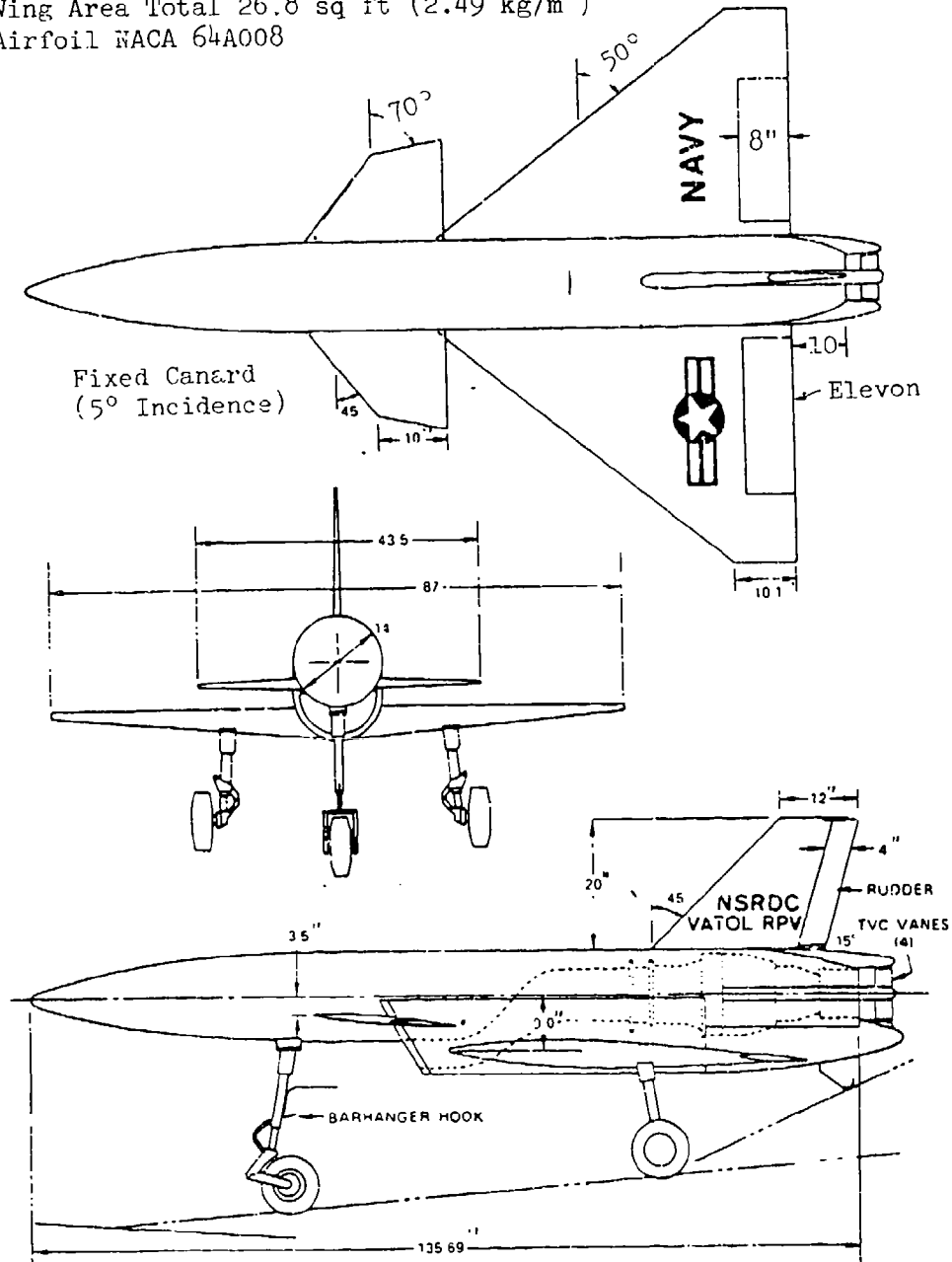

Figure 3.3.4.2 DTNSRDC XBQM-108A General Arrangement  
(from Reference 3.3.4.2)

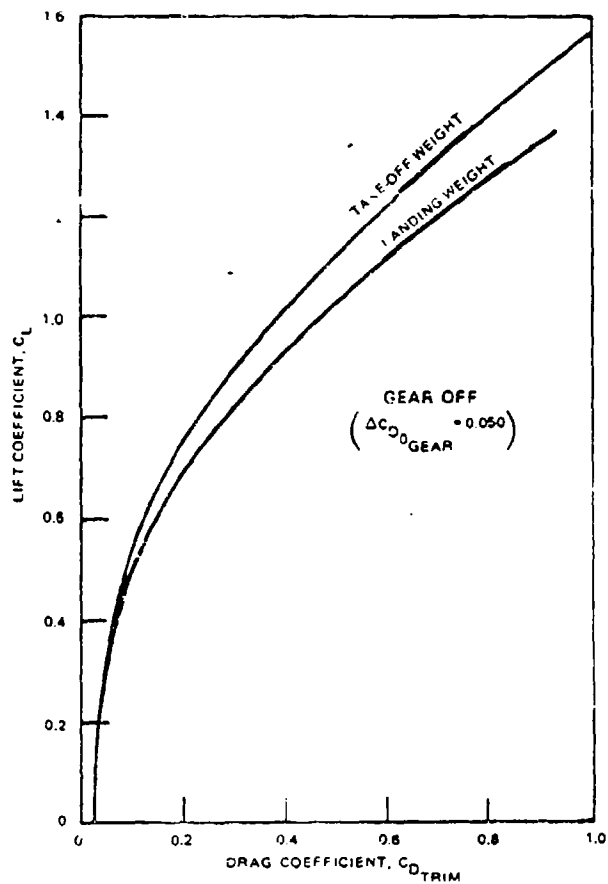

Figure 3.3.4.3 DTNSRDC XBQM-108A  
 $C_L$ - $C_D$  Characteristics  
(from Reference 3.3.4.1)

times the minimum drag of the basic XBQM-108A, causing the best L/D to fall to about 3.5. An operational BQM-108A, being a VATOL aircraft, would not have a landing gear.

TABLE 3.3.4.1

**XBQM-108A CHARACTERISTICS**

Max. Speed, Kt (km/hr)	400 (741) @ 5000 ft (1524 m) alt (Arbitrary Limit)
VTO wt, lb (kg)	562.9 (255.3)
VL wt, lb (kg)	477.4 (216.5)
Empty wt, lb (kg)	468.6 (212.5) (includes 159.9 lb (72.5 kg) of equipment)
Fuel wt, lb (kg)	94.3 (42.8)(JP-4)
Span, in (m)	87 (2.21)
Length Overall, in (m)	143 (3.63)
Height Resting on Ground, in (m)	56 (1.42)
Wing Area, Total sq ft (sq m)	26.8 (2.49)
Engine Thrust, Static, Uninstalled, lb (kg)	660 (299.3)(S.L.)
Engine Thrust, Static, Installed, lb (kg)	625 (283.4)(S.L.)
Wing Loading, lb/sq ft (kg/sq m)	21.0 (102.5)
VTO Thrust/Weight	1.11

Propulsion: The 660 lb thrust (uninstalled) Teledyne CAE XJ402 turbojet engine used in the demonstrator airplane weighed 98 lbs giving it an uninstalled T/W = 6.7. This engine has a compression ratio of 5.6 and a thrust specific fuel consumption of 1.17 lb/lb thrust/hr at maximum thrust. Its diameter is 12.5 inches and length is 27 inches. The engine is of the expendable type, designed for short life operation (30 minutes at full thrust) in the horizontal attitude. In practice, it was found that the engine could operate for longer periods. Repacking at one hour intervals was necessary for its grease packed bearings. Three engines were used during the testing effort. The final engine, incorporated into the actual airplane, was run for a total of 104 minutes, primarily in the vertical attitude. However, most of the operation was at well below maximum rating and, hence, less demanding than for an operational RPV.

Air for the engine was supplied by a belly-mounted, "Kidney"-shaped inlet with a relatively large radius lip to minimize flow separation in hover flight. An "S" shaped duct (designed by NASA's Lewis Research Center) connected this inlet with the engine entrance, the duct being sized to have a relatively large (1.1) area ratio. At the 560 lb hover thrust the engine exhaust gas temperature ranged up to 1425°F and

dynamic pressures reached 1410 psf. The exhaust flow was used to draw ambient air through an ejector to cool the aft engine compartment with the cooling air being drawn through vent openings in the fuselage sides. The mixing of the engine and ambient air flows reduced both temperature and dynamic pressure in the nozzle boundary layer area.

Ground tests with the engine installed in the fuselage revealed that the installed thrust could approach 625 lb (S.L.). Since design VTO weight was 563 lbs, the airplane T/W was 1.11. The installation static thrust loss was 35 lb (5.3%) with the control vanes in place. Inlet distortion, duct and nozzle losses were relatively low. However, a small amount of swirl in the exhaust flow was measured at the control vane location.

Because of the original design requirements for this engine, its speed (rpm) could be controlled only down to 70 percent of maximum, resulting in a minimum thrust of about 100 lbs. Modification of the engine speed control was not undertaken because of the cost involved. The DTNSRDC believed that the inability to idle the engine could produce problems during CTOL testing since the thrust could not be reduced sufficiently for a conventional (horizontal attitude) landing. Power-off landings were not favored because they eliminated the possibility of taking a "wave-off".

Airplane control during subaerodynamic flight was through thrust deflection by vanes in the engine exhaust (Figure 3.3.4.4). This approach was selected over the more commonly used gimballed nozzle because the vane system was simpler and less expensive. Four independently moveable vanes in cruciform arrangement provided all of the control. Collective movement of the horizontal vanes (elevator) pitched the airplane; similarly the vertical (rudder) vanes produced yaw. Differential motion of all four vanes was used for roll.

The vanes used a NACA 0006 airfoil and were mounted in the ejector pipe two inches ahead of the end of the tailpipe to operate substantially within the high velocity engine exhaust (1410 psf dynamic pressure, temperatures as high as 1425°F). The vanes appear in Figure 3.3.4.2 in their original location aft of the tailpipe end. The later location, within the tailpipe, used in the actual XBQM-108 is shown in Figure 3.3.4.4. That portion of the vane surfaces exposed to the mixed ambient air-hot gas flow experienced lower temperatures and pressures (average dynamic pressure, 825 lb/sq ft). Carbon bearings were used for the vane pivots plus heat shields to handle the high temperature environment. Temperature at the bearing housing was only 265°F.

Vane movement of  $\pm 12^\circ$  was provided by electro-mechanical actuators located in four housings at the top, bottom and sides of the rear fuselage. Collective movement of

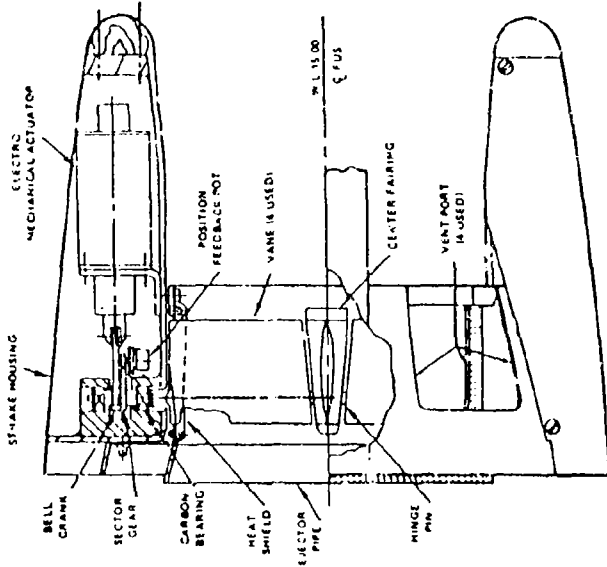

Figure 3.3.4.4 DTNSRDC XBQM-108A Thrust Vectoring Control Vane Assembly  
(from Reference 3.3.4.2)

the vertical (rudder) and horizontal (elevator) vanes produced yaw and pitch control respectively; differential movement of all four vanes was used for roll control. The force capability of the vanes was:

Horizontal vanes	2.82 lb/deg
Vertical vanes	1.46 lb/deg

The possibilities of replacing the turbojet engine with a turbofan were considered by the DTNSRDC because it would considerably increase the XBQM-108A's range and endurance potential due to the turbofan's better specific fuel consumption. A candidate turbofan engine was the Williams F107-WR-200 used to power the Tomahawk cruise missile. It weighed 128 lb (30 lb more than the turbojet) and could be fitted readily into the existing fuselage. Installed static thrust was estimated to be 598 lb or 27 lb less than that of the turbojet. It appears that some airframe and/or equipment weight reduction would have been required to make use of this turbofan engine.

Airframe: The structure of the airplane followed generally conventional practice, with no specific effort being made to minimize airframe weight. No advanced composite materials were used, but simplifications in the structure were incorporated to reduce cost. Specifically, the main wing, canard surface and vertical tail were built using aluminum stringers and plates covered with high density styrofoam bonded to layers of fiberglass. Mahogany was used to make the elevons and rudder.

The nose section was taken en toto from a MQM-74A target drone and housed the command and control receiver and decoder. An aluminum frame, stringer and skin aft structure was used in the fuselage. This contained the engine, supported at a single station using a steel ring attached to five engine support pins. The belly-mounted air inlet was made of fiberglass. Fuel tanks were located in the wings.

Attached to the wings and forward fuselage was the conventional tricycle, fixed (non-retractible) landing gear. A "barhanger" hook welded to the nose gear (shown on Figures 3.3.4.1 and 3.3.4.2) permitted VATOL operation from a horizontal cable or bar. Hydraulically operated brakes were used on the main wheels. To assist deceleration in horizontal run-on landings a drag parachute was incorporated into the fuselage tail cone. For emergency recovery of the demonstrator XBQM-108A, a MQM-74A recovery parachute was to be installed in the upper fuselage. Neither of these parachute systems was to be included in an operational version of the RPV.

With the stabilization equipment installed (25 lb Harpoon Midcourse Guidance Unit), the empty weight of the XBQM-108A was 333.7 lb. Based on a VTO weight of 562.9 lb the EW/GW ratio was 0.59. The DTNSRDC indicated that a mission-capable

design would make extensive use of Kevlar composite materials which would reduce the airframe weight to 110 lb (from 203.7). This 93.7 lb saving could be used to increase the fuel load and/or compensate for the lower thrust and increased weight of the alternative turbofan engine.

Flight Control: The design of the exhaust vane control system was aimed at providing the angular accelerations specified in specification MIL-F-83300: pitch 0.5 rad/sec<sup>2</sup>; roll 3.0; yaw 0.6. Initial design estimates indicated that 2 inch chord vanes would provide the specified pitch and yaw control power with only moderate angular deflections but that the roll control power would be weak. However, this was accepted because it appeared to be adequate to handle the test vehicle when flown in low winds. During static testing of the control system (at Naval Weapons Center, China Lake, California) it was found that the control power available was lower than estimated and changes in the vanes and installation were made. The horizontal vane span was increased and extended to the center fairing and the vanes were moved forward to be nearer to the engine (high dynamic pressure) exhaust. The resulting improvement increased the pitch and yaw control power substantially and permitted successful controlled hover flight during the tethered tests in 1976. The final control powers available were estimated to be:

TABLE 3.3.4.2

ESTIMATED CONTROL POWERS AVAILABLE FOR XBQM-108A

	<u>Rad/sec<sup>2</sup>/Degree</u>	<u>Maximum Single Axis rad/sec<sup>2</sup></u>
Pitch	0.219	2.63
Yaw	0.113	1.36
Roll	0.370	0.44

The vane angular movement available was  $\pm 12^\circ$ .

Because the airplane c.g. was below the engine thrust line a 3000 in-lb nose-down moment existed in hover. It was necessary to install the pitch control vanes with the trailing edge 10° up, this becoming the neutral position during VTO.

Height control in hover was through control of engine speed with the engine controller calculating the speed command based on engine characteristics (thrust vs. RPM and associated lag). This manual type of controller was used because it did not require a speed command reference such as a radar altimeter (that is, the engine speed needed to hover did not have to be known). The height control system provided satisfactory response during hover simulations.

Another design condition for the hover controls was the effect of winds on airplane moments. Tests of the XBQM-108A 30% scale model in the DTNSRDC 8'x10' subsonic wind tunnel had been run in the vertical flight mode as well as the horizontal mode. The vertical mode tests were done at 63 mph airspeed (10 psf) and covered 0° to 180° roll angles at 90° airplane angle of attack. The following was found:

TABLE 3.3.4.3

**XBQM-108A FORCE AND MOMENT CHARACTERISTICS  
 AT 90° ANGLE OF ATTACK**

	<u>Roll Angle*</u>	<u>Coefficient**</u>	<u>Moment or Force for XBQM-108A in 30 kt wind</u>
Max. Rolling Moment Occurs @	170°	$C_l = -0.138$	27.6 ft-lb
Max. Yawing Moment Occurs @	140	$C_n = 0.092$	184 ft-lb
Max. Pitching Moment Occurs @	180	$C_m = 0.148$ (e.g. for VTO)	29.6 ft-lb
Max. Side Force Occurs @	0 & 120	$C_Y = 0.87$	56.6 lb
Max. Normal Force Occurs @	0	$C_N = -1.84$	113.6 lb

\* Zero angle is with wind at right angles to wing lower surface.

\*\* Referenced to 7.25 ft span, 21.74 sq ft wing area or 3.58 ft mean aerodynamic chord.

The forces and moments on the airplane are a function of the wind speed and in a 30 kt wind the maximum values were expected to be about as shown in the above table. As demonstrated in actual hover tests these were within the control capability of the vanes. Simulations of the stabilized airplane hovering in crosswinds indicated that a gust of 26 kts would cause the airplane to displace horizontally 12.5 ft and pitch over 8° from the zero wind equilibrium condition. A wind gust of 58 kts caused a 25 ft horizontal displacement and a 50° pitch angle response. It appears that gusty air did not produce problems during the tethered hover tests. The hover simulations were done at the Naval Underwater Systems Center.

From the horizontal attitude 30% scale model wind tunnel tests, made at 153 mph (60 psf), the longitudinal stability and lateral-directional characteristics were obtained (Figures 3.3.4.5 and 3.3.4.6 respectively). Positive longitudinal stability was evident up to 26° angle of attack and longitudinal elevon control was available to 36° angle of attack. Directional stability (+ $C_{n\beta}$ ) was maintained and actually increased with angle of attack up to 26° angle of attack. This was attributed to the improved flow effect of the close-coupled canard surface. Positive dihedral effectiveness (- $C_{l\delta_2}$ ) also increased with angle of attack. This was ascribed to the improved flow over the wing generated by the canard surface vortices at high angles of attack.

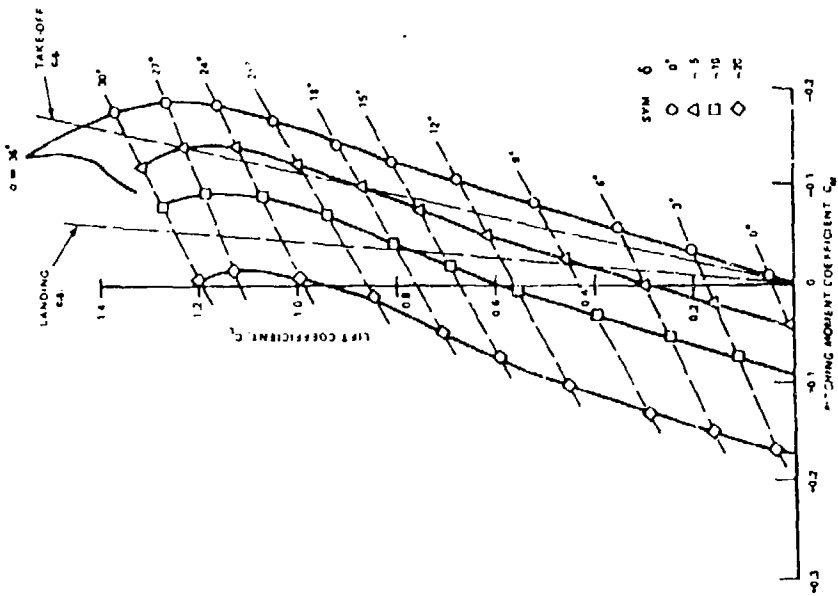

Figure 3.3.4.5 DTNSRDC XBQM-108A  
 Static Longitudinal  
 Pitching Moment  
 Characteristics  
 (from Reference 3.3.4.1)

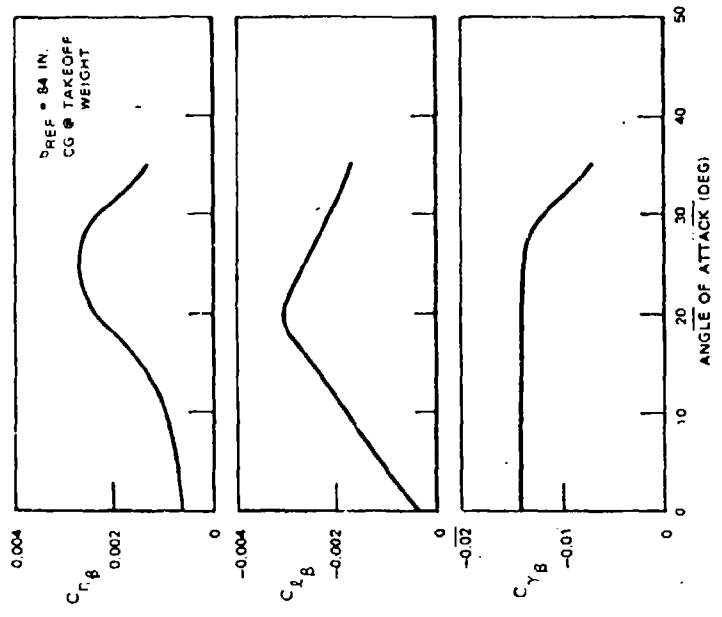

Figure 3.3.4.6 DTNSRDC XBQM-108A Lateral-  
 Directional Stability  
 Characteristics  
 (from Reference 3.3.4.1)

Adequate lateral-directional control was available from the elevons and rudder. Aileron effectiveness ( $C_{l\delta a} = -.002$ ) was maintained up to angles of attack of  $30^\circ$  and was retained to sideslip angles exceeding  $15^\circ$ . The rudder was effective up to the stall angle ( $30^\circ$ ) and at high sideslip angles. Large rudder travel had been incorporated ( $\pm 30^\circ$ ) in an attempt to maintain aerodynamic directional control during transition from conventional to hover flight.

Unlike the manned VOTOL airplanes, this remotely piloted vehicle did not incorporate control mixing and phasing (between roll and yaw control) during transition. Control during VTO, transition and landing did not require visual cues from on-board the RPV, piloting being done from the ship's deck with the pilot watching the airplane during vertical and conversion flight.

It was planned to incorporate the autopilot functional changes required between subaerodynamic and conventional flight modes; however the XBQM-108A program was stopped before this was done. Stabilization in all flight modes was to be provided by the Harpoon missile midcourse guidance unit (MGU), an integrated package designed to provide guidance and control from take-off to terminal guidance take-over. The MGU served as both autopilot and inertial navigator by means of an attitude reference assembly in a strapdown inertial sensor configuration, a digital computer autopilot, and a self-contained power supply. All of these were packaged within a 12 inch diameter, 6 inch long cylinder; the resulting unit weighed 25 lb.

The MGU controlled the elevons and rudder through rotary electro-mechanical actuators using servo amplifiers. Also controlled by the MGU through linear electro-mechanical actuators (Figure 3.3.4.4) were the vanes in the engine exhaust.

Height or altitude was sensed in both conventional and vertical flight using a Harpoon radar altimeter. Radar transmitting and receiving antennas were mounted, one on each lower wing surface ahead of the elevons and remained flush against the wing in conventional flight. As the airplane rotated through  $90^\circ$  to hover, the hinged, spring-loaded antennas swung down  $90^\circ$  to measure hover height.

A Harpoon signal conditioner and telemetry tray was installed for use during the planned free-flight test phase to transmit over 60 pieces of information on performance, engine parameters and flight control position and deflection rates.

During the development of the XBQM-108A, vertical flight of the vehicle was simulated by the Naval Underwater Systems Center (NUSC). The NUSC used DTNSRDC data (vehicle

mass inertias, aerodynamic characteristics and jet vane control power) to perform a stability and control analysis. Subsequently, they developed a digital simulation program to demonstrate the feasibility of controlling the airplane in hover using jet vanes. The simulation explored the motions of the vehicle resulting from flight in crosswinds; the results of this were covered earlier.

During the simulation the autopilot controlled pitch, roll and yaw angular motions of the airplane. Height also was controlled by the engine controller part of the autopilot. Horizontal motion was manually controlled by proportional stick commands to the autopilot outputs.

Although the DTNSRDC did not analyze the specific benefits possible from thrust vectoring in conventional mode flight, they recognized the potential and indicated that, on some RPV configurations, the jet vanes might be used to minimize the need for aerodynamic control surfaces. This could simplify the design of an operational vehicle.

Tethered Hover Tests: Tethered hover tests were done (with canard surface removed) at the DTNSRDC's facility during the latter part of 1976 (first flight September 29, 1976) and were considered successful. Twenty-three flights were performed in wind conditions ranging from calm to 30 kts, with flight time totalling over 8 hours. One purpose of the tethered hover tests was to provide the crew with flight experience and this was still in process when the project was suspended in 1977. The next step was to have been free hover flight, first on land and later aboard ship. During the tethered hover tests, time histories were taken of engine speed command, exhaust gas temperature, vane motion, pitch attitude, height and tether cable load.

Figure 3.3.4.7 shows the XBQM-108A in hover flight with the trapeze support bar in near-horizontal (unloaded) position. This trapeze bar was attached to the airplane ahead of the c.g. near the canard surface mount fitting and was free to pivot about a horizontal axis. It allowed the vehicle to be supported by a cable hanging from the boom of a crane when not being lifted by the jet thrust. An electric cable passing through the boom, suspension cable and trapeze system connected the ground station with the RPV permitting transmission of override commands for translation fore, aft and sideways, rotation about the vertical axis and height change. The cable also provided electric power and signal transmissions between the airplane's instrumentation and recording equipment on the ground, as well as a fuel line to allow the engine to operate continuously.

Figure 3.3.4.8 shows the complete tethered test system. The XBQM-108A rested on the flatbed trailer which had an erecting system. The engine was started in the horizontal

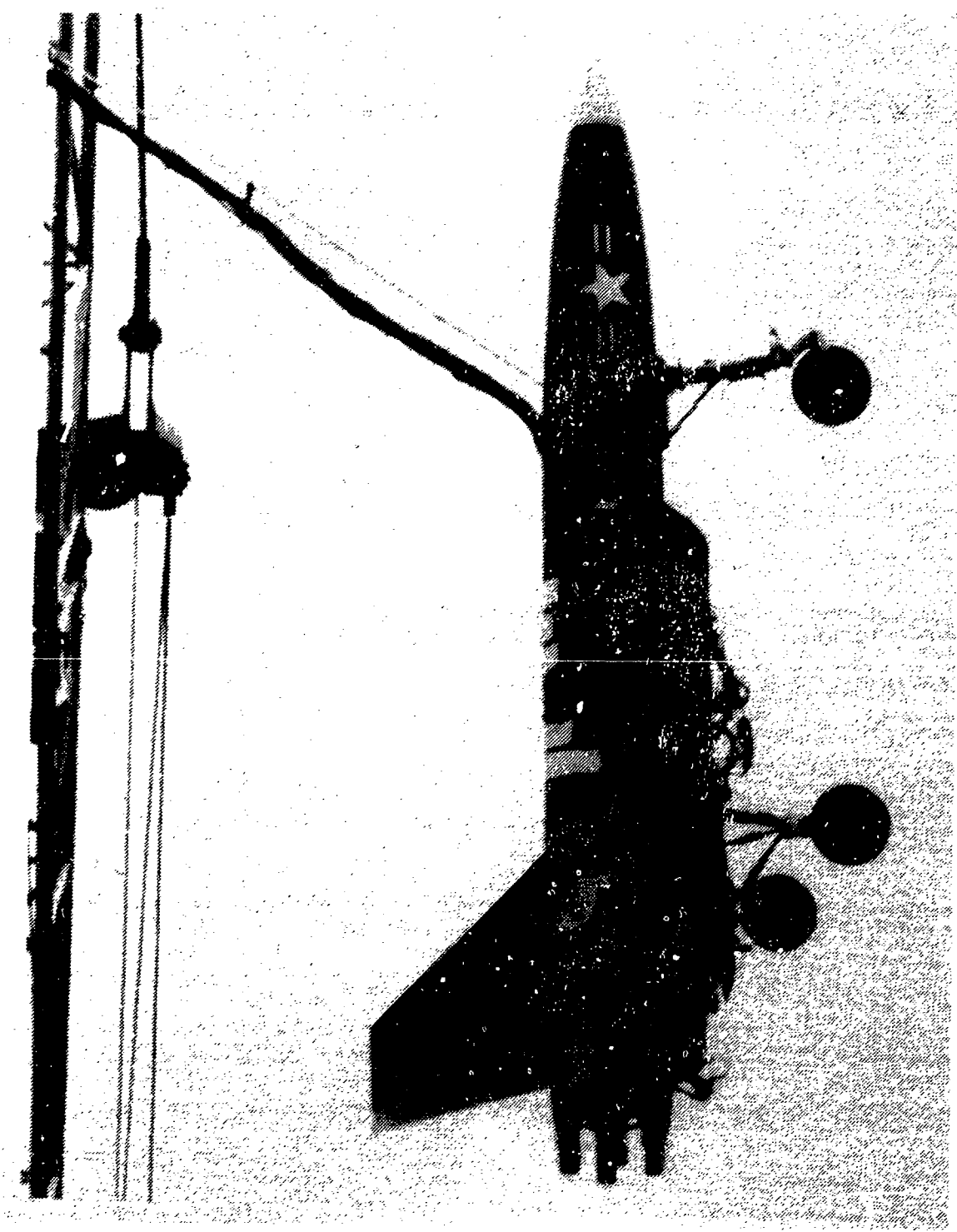

Figure 3.3.4.7 DTNSRDC XBQM-108A In Tethered Hover Test  
(from Reference 3.3.4.2)



Figure 3.3.4.8 DTNSRDC Tethered Test System for XBQM-108A  
(from Reference 3.3.4.2)

attitude and chocks were used to keep the RPV in place. When the flatbed was erected a horizontal cable engaged the nose gear hook and supported the airplane's weight. With the flatbed in the vertical position the crane lifted the airplane via the trapeze system and moved it away from the flatbed. Jet blast was diverted at the ground by a steel deflector plate. A load cell between the trapeze support bar and support cable registered the weight being carried by the cable. When the airplane was fully supported by engine thrust it could be elevated to a position where the trapeze unit rotated to an approximately horizontal attitude and supported none of the airplane's weight. Safety tether lines, which could be released, were attached to the wing tips.

Shipboard and Ground Handling: The effect of RPV's on ship operation had been studied in a separate task and the results were published in August 1974 (Reference 3.3.4.3). Three sizes of RPV's were investigated on several different size shps. A 10-day base line mission was assumed; crew sizes required to support the RPV operations were determined.

Prior to the cut-off of program funding, plans were being developed to investigate the methods of operating a VATOL RPV on ships underway, covering ship motion and platform stabilization. During the development of the XBQM-108A initial consideration was given to the use of a horizontal bar and hook system and to a prong-net system. The latter is shown in Figure 3.3.4.9. Recovery net size was to be determined using ship motion data in sea states up to 5. It was visualized that the RPV would approach the ship from behind being directed to the net by a controller on the ship. Net size was to be sufficiently large to insure capture.

Performance Capabilities: The primary purpose of the demonstrator XBQM-108A was to prove the viability of a VATOL concept in take-off and landing from a ship underway in realistic seas and winds. Hence, the level flight performance was only a secondary consideration.

With the high thrust-to-weight available in high speed flight, the RPV could have reached near sonic speeds but, to minimize the structural design complexity, the speed was to be limited to 400 kt at 5000 ft. Calculations indicated that, with the landing gear in place, maximum range would be 147 nm and, at 5000 ft, would occur at  $M = 0.4$ . Flight time would be 29.5 minutes. The thrust required was expected to be 231 lbs and 76 lb of fuel (94 lb available) would be used. Time to climb to 5000 ft was estimated to be 8.8 sec.

With respect to a running take-off, it was estimated that nose wheel liftoff would occur at 120 kt after a ground roll of 600 ft. This was based on 563 lb gross weight, an engine thrust of 546 lb and a rolling resistance coefficient of 0.03. Only elevon control (trailing edge up  $40^\circ$ ) was used to

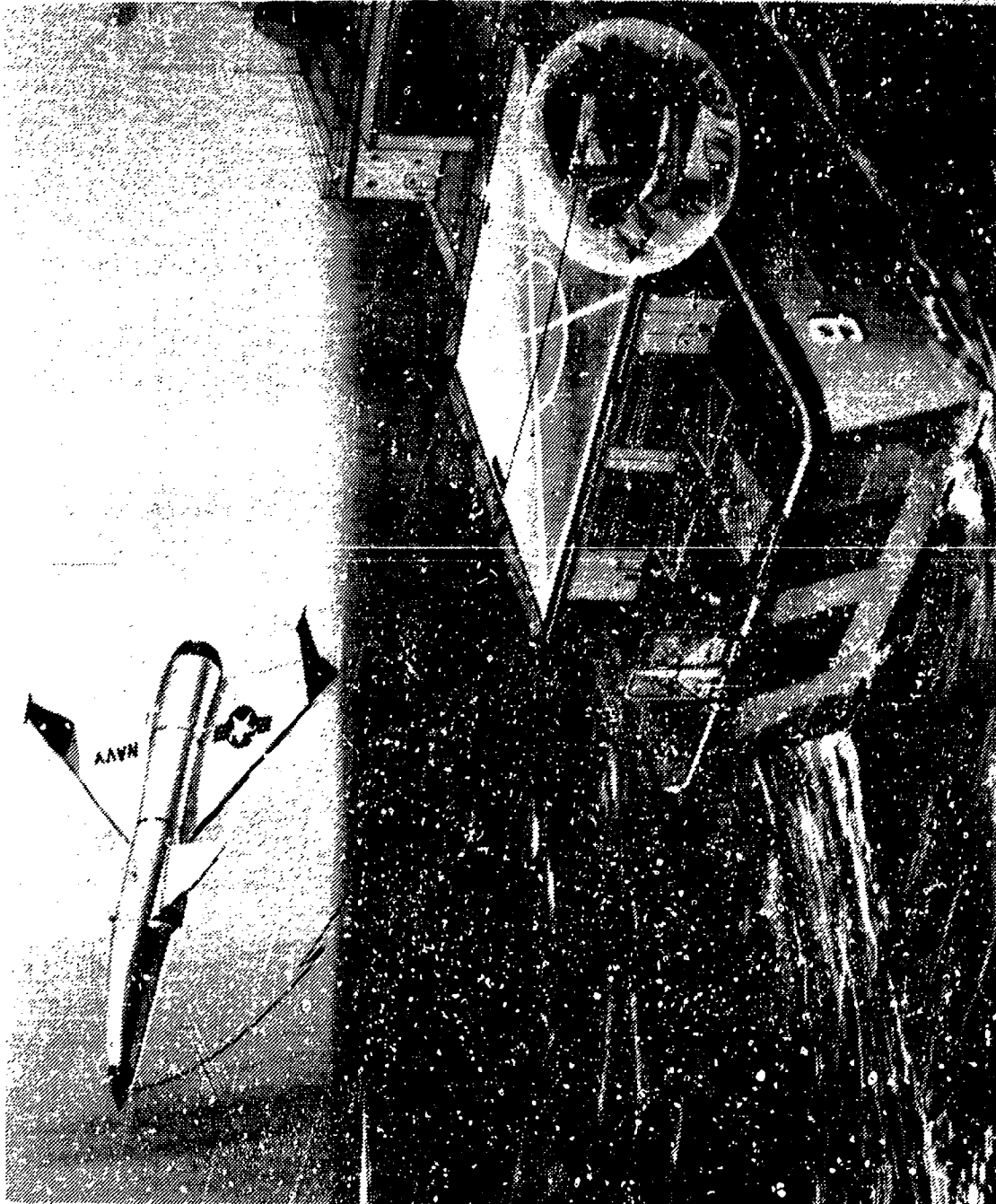

Figure 3.3.4.9 DTNSRDC XBQM-108A Shipboard Launch and Retrieval Concept  
(from Reference 3.3.4.1)

rotate the airplane; thrust vectoring was not employed. However, at a  $C_L$  of 1.2 ( $C_L$  for  $V_{stall} = 1.4+$ ) sustained flight speed was expected to be less than 80 kt and a shorter take-off distance appears possible, particularly if engine thrust vectoring was used to help rotation prior to liftoff.

As mentioned earlier, horizontal landing with the XJ-402 turbojet engine was expected to be difficult because of the inability to fully idle the engine (minimum thrust setting was about 100 lb). Because of this situation the use of a pull-up maneuver was analyzed. It was determined that a landing could be made starting from a height of 124 ft, 100 kt speed and a 11 fps sink rate. A 1.02 g flare would put the RPV at 50 ft altitude with a 5 fps sink rate to a touchdown at 75 kt speed.

The advanced version of the XBQM-108A with a composite material airframe and a turbofan engine (Williams F107-WR-400) was to carry more fuel and have a substantially lower specific fuel consumption. With the Harpoon MGU (used as the autopilot) and a forward looking infrared sensor installed, it was projected to have the following characteristics:

TABLE 3.3.4.4

MISSION CAPABILITIES OF XBQM-108A WITH TURBOFAN ENGINE

	Vertical Takeoff (internal fuel only)	Catapult (or booster) Launch (internal plus external fuel)	
		Long Range	Long Endurance
Range to target area, nmi	85.0	280.0	85.0
Endurance time at target area, hr	1.0	1.0	3.0 (specified)
Flying time to target, min	14.4	63.0	23.0
Average speed to target area, knots	332.0	296.0	22.0

The above performances were based on the availability of 160 lb of internal and 140 lb of external fuel and included 30 seconds warmup, 15 minutes of pre-landing sea level loiter, fuel reserve 5%. Dash speed capability was 400 kt; its use would lower time to target area but reduce endurance. Additional external fuel could be used to increase range or endurance on station.

DTNSRDC's Conclusions: The significant conclusions reached by the DTNSRDC are:

1. VATOL offered an attractive solution to launch and recovery of Navy RPV's as well as manned V/STOL aircraft aboard ships.

2. The XBQM-108A provided the Navy with a valuable tool to assess vertical docking aboard ships underway.

3. The aerodynamic characteristics of the close-coupled canard/delta wing configuration appeared to be superior to those of other candidate systems. Higher lift generated by the canard made transition easier from horizontal to vertical flight and also allowed touchdown speeds in conventional landings.

4. VATOL aircraft would have minimal impact on ship operations because they use the deck edge for launch and recovery and had their engine exhaust directed overboard. The NSRDC did not examine the problem of jet blast impingement on the water, which is a serious concern within the Navy (ship stationary). This is not considered a problem when the ship is underway.

Concluding Observations: The XBQM-108A was a good program which probably merited continuation as a VATOL exploratory tool for both the manned and unmanned vehicle (RPV) areas. By 1982 the Navy's interest had gravitated to the Short Take-Off Vertical Landing (STOVL) approach; consequently there is little Navy interest in VATOL (1985).

For recoverable unmanned aircraft, VTOL continues to have merit as a potential approach to eliminating complex launch and recovery apparatus and, possibly, offering total system cost savings over the conventional type of RPV. VATOL, because it is the simplest and lightest of the VTOL concepts, is a highly attractive approach for such RPV's. Being unmanned, there are no human factors problems. As of 1985 the Navy's unmanned aircraft effort (other than cruise missiles) is in abeyance. The Army apparently has no requirement for a high speed RPV, such as would be derived from the XBQM-108A propulsion approach (TF engine) and the Air Force is not developing any new, recoverable unmanned aircraft.

REFERENCES - SECTION 3.3.4

- 3.3.4.1 Eilertson, Warren H., "Remotely Piloted Vehicle/ Vertical Attitude Take-Off and Landing Demonstration Vehicle", Aviation and Surface Effects Department Research and Development Report 4697, Aug. 1975. (Also found in the Proceedings of the American Helicopter Forum, May 1975 and Proceedings, National Association for Remotely Piloted Vehicles, June 1975.
- 3.3.4.2 Eilertson, Warren H., "A Naval VATOL RPV in Testing", Astronautics and Aeronautics Publication of the AIAA, June 1977.
- 3.3.4.3 Bergan, Elmer and Sekellich, Michael A., "Remotely Piloted Vehicles/Ship Interface Investigation, Part I Summary", Aviation and Surface Effect Dept. Research and Development Report 326, August 1974.

3.3.5 Vertical Attitude Take Off and Landing (VATOL)  
 Airplane Design Studies (1954-1978)

3.3.5.1 Introductory Comments

Although all of the VTOL aircraft developments since the late 1950's have been based on the horizontal take-off and landing approach there has been a continuing, though sporadic, interest in VATOL concepts, particularly for fighter aircraft. Because of the relative simplicity and performance potentials of the VATOL aircraft this interest can be expected to persist into the future. From 1954 through 1977 a number of serious design studies were done. Of these, the ones listed in Table 3.3.5.1 have been selected for review to show conceptual and design advances made since the advent of the F-13. Table 3.3.5.2 summarizes information regarding these designs.

TABLE 3.3.5.1  
 VATOL AIRCRAFT DESIGNS REVIEWED

<u>Section No.</u>	<u>Company</u>	<u>Model Designation &amp; Type of Aircraft</u>	<u>Sponsor</u>	<u>Contract No.</u>	<u>Date</u>
3.3.5.2	Temco	39, Day Fighter	USAi	AF33(616)-2314	1953
3.3.5.3	Convair	VTOL Day Fighter Configuration IVa	USAF	AF33(616)-2313	1953
3.3.5.4	Lockheed	CL-295-1, Day Fighter CL-295-4, Day Fighter	USAF USAF	AF18(600)-1232 AF18(600)-1232	1954 1954
3.3.5.5	Ryan Aeronautical	84, Day Fighter 112, Visual Fighter 115, Fighter-Bomber 115C, Fighter-Bomber	USAF Company USAF Company	AF18(600)-1157 -- AF18(600)-1641 --	1954 1956 1956 1957
3.3.5.6	Focke-Wulf (Fed. Rep. of Germany)	FW-860, Interceptor	Company	--	1960
3.3.5.7	Boeing	Sea Control Fighter	Company	--	1971
3.3.5.8	Northrop	N366-12, Fighter	NASA (Ames) Navy (NSRDC)	NASA2-9771	1978
3.3.5.9	Vought	SF-121, Fighter	NASA (Ames) Navy (NSRDC)	NASA2-9772	1978
3.3.5.10	Grumman	"Nutcracker", Multi- Purpose Subsonic	Company	--	1976

During 1975 the NASA Langley Research Center conducted experiments on electrically powered free-flight models of the General Dynamics YF-16 and Northrop YF-17 (antecedent of the F-18) airplanes in their 30 x 60 ft wind tunnel. The models contained modifications to permit their

TABLE 3.3.5.2  
 SUMMARY OF VATOL AIRCRAFT DESIGN CHARACTERISTICS

Company & Aircraft Designation	Time Period of Effort	Type of Aircraft	Primary Mission	T.O. & Landing System	Maximum Speed, Mach at altitude, ft	Combat Ceiling, ft	Rad. Action, m/Sec, lbs	Des. T.O. Alt ft/Temp °F	Installed Thrust/Normal T.O. G.W.
Boeing B-73	1952-53	Conquest Supersonic	Research	Hanging	32, kts (design)	--	not a requirement	S.L. std day	1.05
Temco T-28	1953-54	Day Fighter	Air-Air Combat	Tail-sitter	2.02 50,000	60,000	77/945	S.L. std day	1.20
Convair Day Fighter Configuration 774	1954	Day Fighter	Air-Air Combat	Tail-sitter	2.02 58,000	65,000	250/925	S.L. std day	1.10
Lockheed L-2052	1954-55	Day Fighter	Air-Air Combat	Hanging	2.002 over 50,000	60,000	200/1,000	S.L./799	1.05
Lockheed L-2051-4	1954-55	Day Fighter	Air-Air Combat	Self-erecting tail-sitter	2.52 over 40,000	63,000	300/1,000	S.L./799	1.05
Boeing Model 184	1954-55	Day Fighter	Air-Air Combat, Nuclear Bomb, Belly	Hanging	2.01 @ 50,000	63,500	238/800	3,000/100	1.05
Boeing Model 810*	1954-55	Day Fighter	Air-Air Combat, Nuclear Bomb, Belly	Hanging	2.5 @ 50,000	70,600	523/820	3,000/100	1.05
Boeing Model 712	1955	Visual Fighter	Air-Air Combat, Nuclear Bomb, Belly	Hanging	2.0 M	MA	MA	MA	1.05
Boeing Model 115	1957	Fighter Bomber	Air Combat/Ground Attack	Hinging	2.2 @ 64,000	67,000	384/1,000	7,000/90	1.05
Boeing Model 115	1957	Fighter Bomber	Air Combat/Ground Attack	Turning	5.2 62,000	65,000	900/1,000	7,000/90	1.05
Focke-Loewer F-106	1957	Interceptor	Air Combat/Interceptor	Self-erecting tail-sitter	Max 2+ Altitude MA	MA	250/1,000	MA	MA
Boeing Sea Control: F-107	1957-72	Interceptor	Naval Supersonic (Point Intercept)	Hinging	2.6 @ 73,000	over 73,000 ft	150/1,600	S.L./89.6	1.41
Aerotech M200-12	1971-78	Fighter	Naval Fighter (Point Intercept)	Hanging plus S.G.	1.8/63,000 1.75/40,000	Approval 62,000	562/1,300	S.L./89.6	1.17
Boeing Model 115	1971-75	Fighter	Naval Supersonic (Point Intercept)	Hanging plus I.G.	2.40/2 48,000	60,640	150/1,300	S.L./89.6	1.29
Boeing Model 115	1974-78	Subsonic Multi-purpose	Naval Light Attack Multi-purpose System (LAWES)	Horizontal Platform over fuselage non-tilt, S.G.	0.7 @ 50,000	--	280/1,700	S.L./89.6	1.21 at T.O. power

1. Operational empty weight of engine  
 2. Max lift of engine  
 3. Thrust design limit  
 MA - not available  
 SG - landing gear

TABLE 3.3.5.2 (Continued)

Aircraft Designation	Number, Engine & Total Thrust, lbs (uninstalled)	Max. VTO G.W., lbs (5.5 sec dry)	Empty wt., lbs	Combat wt., lbs	Dimensions, ft length span height	Type of Main TE Jump	Vertical Flight Control	Engine T/W (uninstalled) (S.L. Std. 1)	Performance, G.M.
Boeing F-15	1 RR Adv. TC 10,000	7,376 (4:50:1)	9,000	5,570	23.4 20.3 16.2	Delta, 60°	(A)	3.6	0.76
Lockheed F-105	2 RR Adv. TC 14,835	21,080	23,315	14,835	51.2 37.5 26.1	Tapered, Sweptback, 60°	(A)	4.6	0.70
Boeing F-105	2 RR Adv. TC 14,835	21,080	23,315	14,835	51.2 37.5 26.1	Tapered, Sweptback, 60°	(A)	4.6	0.69
Lockheed F-105	2 RR Adv. TC 14,835	21,080	23,315	14,835	51.2 37.5 26.1	Tapered, Sweptback, 60°	(A)	4.6	0.64
Lockheed F-105	2 RR Adv. TC 14,835	21,080	23,315	14,835	51.2 37.5 26.1	Tapered, Sweptback, 60°	(A)	4.6	0.61
Boeing F-105	2 RR Adv. TC 14,835	21,080	23,315	14,835	51.2 37.5 26.1	Tapered, Sweptback, 60°	(A)	4.6	0.63
Boeing F-105	2 RR Adv. TC 14,835	21,080	23,315	14,835	51.2 37.5 26.1	Tapered, Sweptback, 60°	(A)	4.6	0.57
Boeing F-105	2 RR Adv. TC 14,835	21,080	23,315	14,835	51.2 37.5 26.1	Tapered, Sweptback, 60°	(A)	4.6	0.62
Boeing F-105	2 RR Adv. TC 14,835	21,080	23,315	14,835	51.2 37.5 26.1	Tapered, Sweptback, 60°	(A)	4.6	0.56
Boeing F-105	2 RR Adv. TC 14,835	21,080	23,315	14,835	51.2 37.5 26.1	Tapered, Sweptback, 60°	(A)	4.6	0.57
Boeing F-105	2 RR Adv. TC 14,835	21,080	23,315	14,835	51.2 37.5 26.1	Tapered, Sweptback, 60°	(A)	4.6	0.52
Boeing F-105	2 RR Adv. TC 14,835	21,080	23,315	14,835	51.2 37.5 26.1	Tapered, Sweptback, 60°	(A)	4.6	0.50
Boeing F-105	2 RR Adv. TC 14,835	21,080	23,315	14,835	51.2 37.5 26.1	Tapered, Sweptback, 60°	(A)	4.6	0.56
Boeing F-105	2 RR Adv. TC 14,835	21,080	23,315	14,835	51.2 37.5 26.1	Tapered, Sweptback, 60°	(A)	4.6	0.54
Boeing F-105	2 RR Adv. TC 14,835	21,080	23,315	14,835	51.2 37.5 26.1	Tapered, Sweptback, 60°	(A)	4.6	0.68

MA - not available  
 TC - thrust vector control  
 A - pitch and yaw thrust vector control at tail  
 B - pitch and yaw thrust vector control at tail plus reaction jets at wing tips for roll  
 C - pitch, roll and yaw used thrust vector control at tail

operation as VATOL aircraft. NASA's interest in the VATOL approach was triggered by the fact that modern fighters such as the F-16 and F-18 are designed with very high thrust-to-weights (T/W) for combat maneuverability reasons and, hence, already have T/Ws for VATOL flight, if adequate control is provided. Figure 3.3.5.1.1 shows the YF-16 VATOL model in a transition sequence from VTO to conventional mode flight. The tests showed that the design techniques used by NASA could be applied successfully to the full-scale aircraft. Figure 3.3.5.1.2 shows the YF-17 model in VTO position.

In June 1953 the U.S. Air Force's Air Research and Development Command circulated a statement of work for a proposed effort whose objective was to determine, through general investigations and design studies, the optimum configuration of a VTOL Light-Weight Day Fighter to perform specified Air Force missions. The Request for Proposal (RFP) was issued in September 1953 and Temco, Convair, Lockheed, and Ryan Aeronautical each won a contract. While the general intent was the same for each contract--to determine the feasibility of a VTOL light-weight fighter, the work statement in each of the four contracts was different. Since the Air Force funding was at a low level (about \$75,000 each) the companies absorbed a substantial part of the study costs. Although interested in VTOL fighters North American Aviation did not seek a contract for the day fighter study. However, in 1955 they did conduct a VTOL fighter-bomber study on their own during which a large number of configurations were investigated based on Air Force proposed requirements. North American concluded that, although the VATOL type was lighter, HATOL was preferable because, with it, ground handling procedure and equipment were considerably simpler, no tilting cockpit or seat was needed and less pilot skill was required.

During the early years VTOL fighters, including the VATOL types, continued to be of interest to the Navy. This is evident from its funding of Ryan Aeronautical's further efforts in 1956 to develop a satisfactory nozzle system for vectoring and modulating the thrust of a J79GE-1 after-burning engine (Reference 3.3.5.1).

Subsequent to the completion of the Light Day Fighter design studies by the four contractors, Ryan was one of those selected by the Air Force to extend the effort to a Dispersed Site Fighter-Bomber system for use in the 1960's and to determine a program for its development, including detailed design of the airplane. Of the four contractors involved in VATOL aircraft investigations during the 1954-1957 period, Ryan Aeronautical was the most dedicated and went furthest in trying to establish this approach to a VTOL type fighter. The Model 115C fighter-bomber design was their final effort to promote such an aircraft and represents the most advanced VATOL design of that time period.



Figure 3.3.5.1.1 Transition of YF-16 VATOL Model In NASA Langley  
40' x 80' Wind Tunnel (Courtesy NASA)



Figure 3.3.5.1.2 YF-17 Model in VTOL Position  
(Courtesy NASA)

3.3.5.2 Temco Design Study (1953-1954)

Temco Aircraft Corporation received a contract from the Air Force Research and Development Command in November 1953 "to determine the most reasonable configuration and size for a vertical take-off and landing (VTOL) Dayfighter aircraft, incorporating an integral landing gear and powered by an Allison J-71 (B-30) turbo-jet engine equipped with a turbofan afterburner". This company was one of four given Air Force contracts during 1953-1954 time period to study VTOL Day Fighter possibilities, the other contractors being Convair, Lockheed and Ryan Aeronautical. The results of the Temco study are summarized in the Temco report listed in reference 3.3.5.2. Temco's contract was for 6 months and called for a study based on guidelines which were similar to ones given subsequently to the other contractors. Both Temco and Convair were required to consider only the Allison J-71 (B-30) turbojet engine equipped with a turbofan and afterburner. Both elected to use the pure tail sitter approach. Figure 3.3.5.2.1 shows the general arrangement of the Temco design which has the designation Model 39.

The performance requirements to be met were based on specification, MIL-C-5011A and are summarized in Table 3.3.5.2.1 along with the Model 39 predicted performance. In addition, the aircraft was to be able to operate from a small area surrounded by 50 foot high obstacles in winds up to 20 Kts. Figure 3.3.5.2.2 provides the mission profile of the airplane based on that prescribed by the Air Force which specifically included the following elements:

1. VTO and transition to conventional attitude flight.
2. Climb to cruise altitude.
3. Cruise to combat area and climb to 50,000 feet.
4. Engage in combat for 5 minutes at M=1.3 at 50,000 feet.
5. Cruise back.
6. Descend to sea level
7. Loiter at maximum endurance speed for 20 minutes.
8. Transition to vertical attitude and land.
9. Have 5 percent of total fuel in reserve.

Manufacturer's Model No. (engine model designation)	36 Allison J-31 (A-30) with Turboprop
Mixing	
Airfoil Section	NACA 0004-0 40/157.
Aspect Ratio	2.67
Area (Total, Incl. Elevons), sq. ft.	394
Incidence, Degrees	0
Elevons	
Area (Each), sq. ft.	20.1
Elevator Travel, Degrees, Up/Down	15/10
Aileron Travel, Degrees, Up/Down	15/15
Vertical Tail	
Airfoil Section	NACA 0004-0 40/1575
Area (Each, Exposed), sq. ft.	41.5
Aspect Ratio	2.67
Ladder Area (Each), sq. ft.	10.3
Ladder Travel, Degrees, Right/Left	15/15
Takeoff Gross Weight, Lbs.	21,039
Empty Weight, Lbs.	14,831
Length, ft.	41.7
Wing Span, ft.	32.0
Vertical Tail Span, ft.	24.8

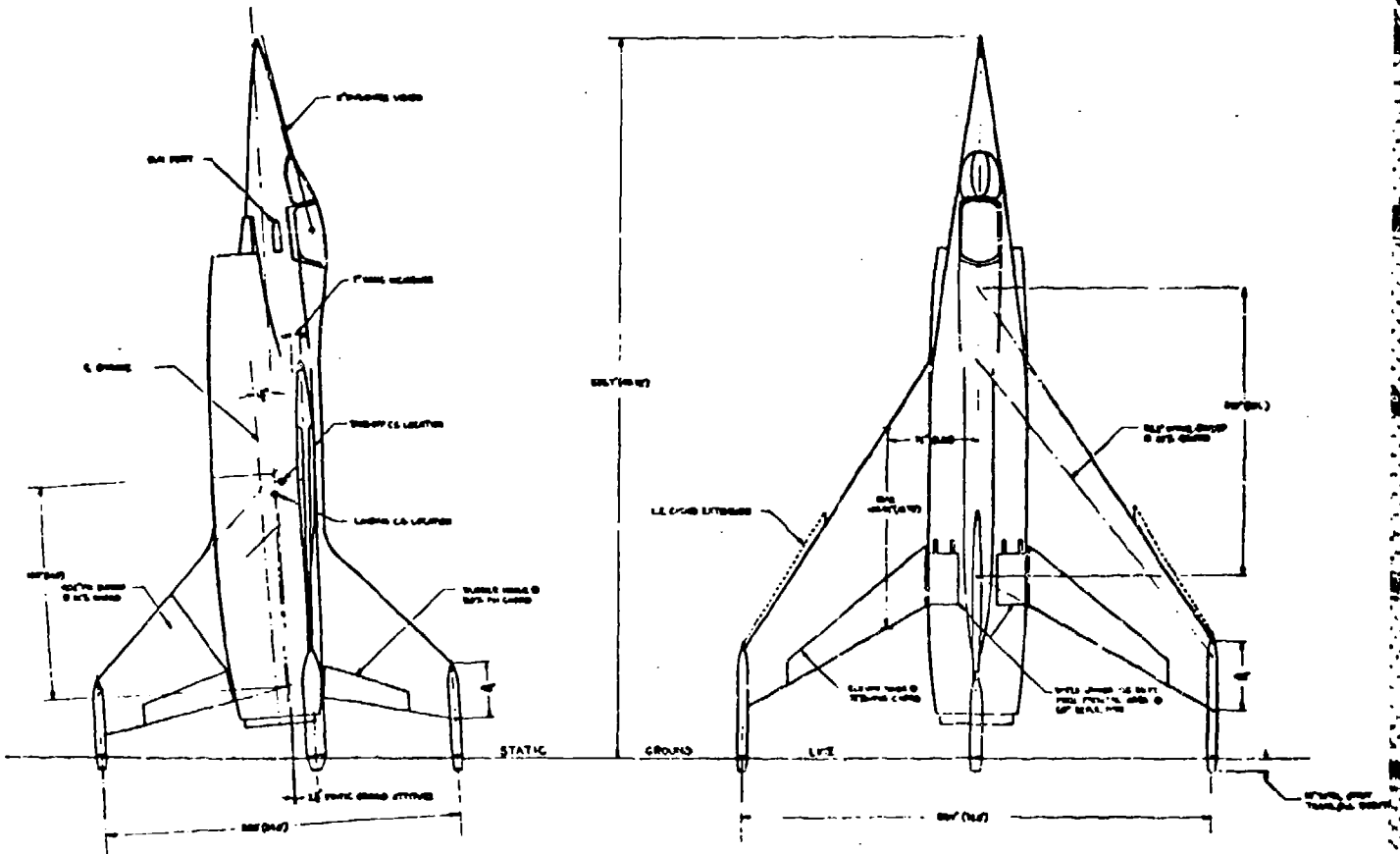
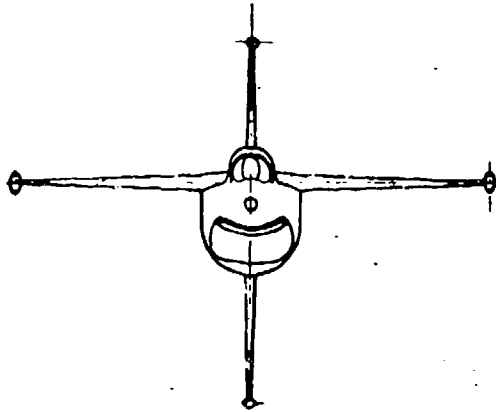

Figure 3.3.5.2.1 General Arrangement Temco Model 39  
 (Courtesy LTV Aerospace)

### COMBAT PERFORMANCE FLIGHT PROFILE

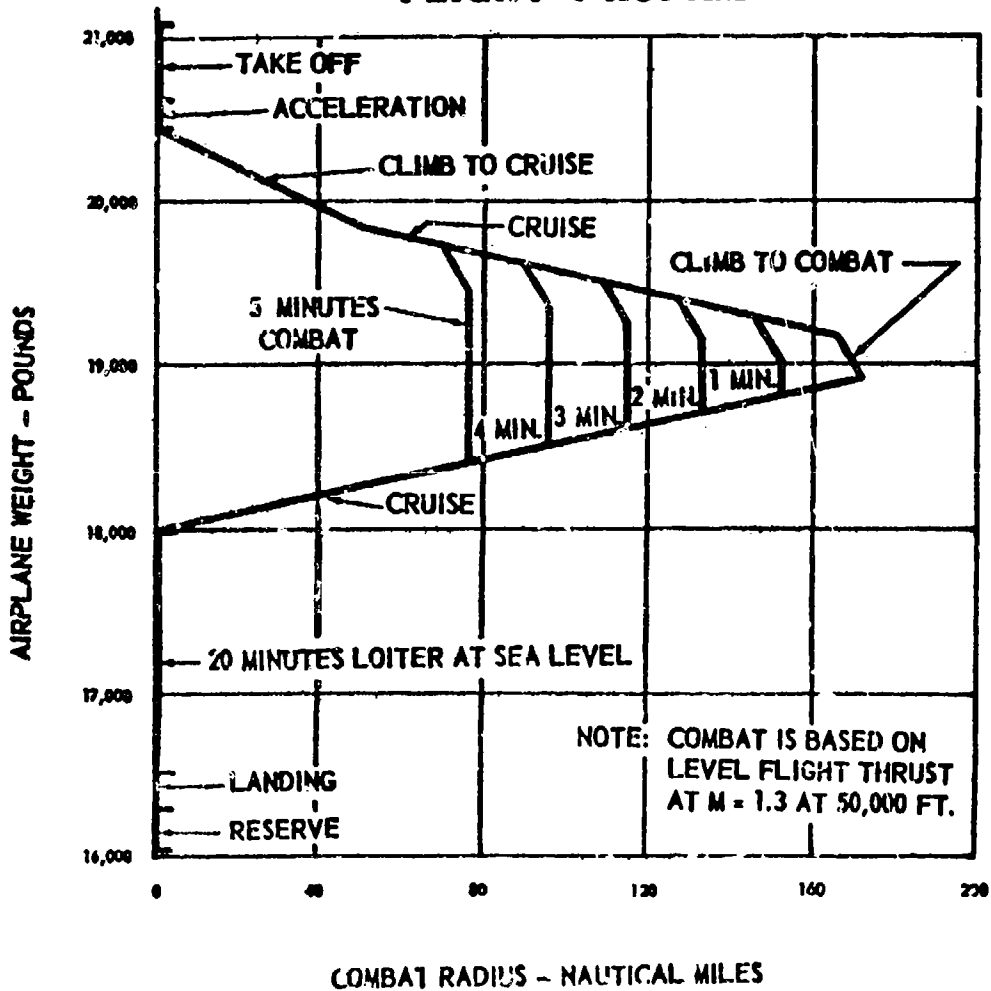

Figure 3.3.5.2.2 Combat Mission Profile Temco Model 39  
(Courtesy LTV Aerospace)

**TABLE 3.3.5.2.1  
 PERFORMANCE SUMMARY  
 TEMCO MODEL 39**

		<u>Requirement</u>	<u>Temco Model 39</u>
At 35,000 Ft. at Combat Wt.,	Lbs	—	19,450
Max Speed,	Mach No.	1.6	2.0*
Accel. Max. Speed (Mil Power) to Max. Speed at 1.2 g, Minutes		3.0	2.33
Max. Speed, Mil. Power,	Mach No.	—	0.97
<b>Combat Radius</b>			
For $M_{\text{combat}} = 1.3$ ,	n.m.	—	77
Combat Altitude,	Ft.	50,000	50,000
Ceiling, Military Power,	Ft.	45,000	42,500
Normal Acceleration, Steady Turn at 45,000 ft.		1.5g —	1.5g, $M=0.97$ 0.9g, $M=1.0$ 2.25g, $M=1.6$
Max. Rate of Climb, SL	Ft./Min.	—	58,000
Max. Rate of Climb, 35,000	Ft./Min.	—	36,000
Max. Speed, S.L.	Mach No.	—	1.0*

\* Engine Limit

For this mission profile, Temco projected only a 77 n.m., radius of action. This poor capability was attributed to the high take-off thrust/weight ( $T/W = 1.2$ ) selected which reduced the fuel load available, the large aircraft drag in cruise flight, the disappointing specific fuel consumption (0.96 lb. fuel/ lb. thrust/hour), and the 20 minute sea level loiter before landing requirement.

Temco selected the tail-sitter concept because it was the most direct approach to meeting the contract stipulation that the VTOL aircraft not be dependent upon any auxiliary devices on the ground for take-off and landing, essentially requiring the aircraft to have an integral undercarriage. The Air Force had requested that the study include an investigation of the concept wherein the pilot stood during VTOL and was in prone position in conventional mode flight. Temco's preliminary investigation of the prone pilot station indicated that the scope of the design problems with this arrangement was too broad to be properly handled during the six month duration of the contract. Only a tilting seat arrangement was considered for the VATOL airplane.

Temco believed that a tail sitter design could be either a canard configuration or tailless. Although the canard configuration appeared to be feasible based on a brief investigation, the tailless approach was selected because of the difficulty of properly analyzing a canard design in the short time available under the contract. The tailless configuration selected used a highly tapered wing with considerable sweepback (as opposed to a delta planform such as used by Convair). This was done to locate the wing tips well aft on the airplane for undercarriage strut attachment and to place the wing root forward on the fuselage for structural reasons and for proper positioning of the aerodynamic chord with respect to the airplane center of gravity. Large dorsal and ventral fins were used. These also were swept back and arranged to accommodate the other undercarriage elements at their tips.

Aside from its tailless configuration and highly swept wing, the principal features of the design (Figure 3.3.5.2.1) are the single turbofan type engine mounted in the aft fuselage, the relatively low fineness ratio fuselage (for a supersonic airplane), the cockpit located well-forward on the fuselage, the shoulder height mounting of the wing, speed control brakes aft on the upper-fuselage surface, the underslung air intake for the engine, the jettisonable lower fin (for use during emergency landings on the belly), the cruciform disposition of the four undercarriage legs equipped with shoes instead of wheels, and attitude control vanes in the exhaust and reaction jets at the wing tips. Table 3.3.5.2.2 summarizes the Model 39's characteristics.

TABLE 3.3.5.2.2  
 CHARACTERISTICS OF TEMCO MODEL 39

Engine		Allison J-71 (B-30) with turbofan
*Rated Thrust,	Lbs.	26,600
*Net Thrust,	Lbs.	25,295
Empty Weight,	Lbs.	14,831
Weight, Zero Fuel,	Lbs.	16,049
Combat Weight,	Lbs.	19,450
*Useful Load,	Lbs.	10,464
*Combat Mission T.O. Weight,	Lbs.	21,079
*Combat Mission Fuel Weight,	Lbs.	5,030
*Take Off T/W		1.2
Span,	Ft.	32.0
Length,	Ft.	51.3
Span Across Vertical Tail,	Ft.	24.7
Wing Area,	Sq. Ft.	320
Wing Loading at Combat Wt.,	Lb./Sq. Ft.	50.7

\*S.L. Std. Day conditions

Take-Off and Landing: Temco investigated two general programs for attitude variation from take-off through transition -- constant pitching acceleration and constant pitching rate. The latter appeared to be slightly superior. The effect of T/W on fuel used and time to reach 1.1 stall speed was examined with T/W values ranging up to 1.26. It was found that when T/W reached 1.095 a sharp upturn occurred in fuel used and transition time. Temco's analysis indicated that the faster the transition, the less the fuel burned and the shorter the exposure time to the possibility of engine failure and uncontrolled crash. Temco selected a T/W = 1.2 to cover thrust losses due to inlet, ducting and engine installation and to favor shorter transition time. This resulted in the take-off weight being pegged at 21,000 pounds. Selection of a 4 degree/second pitching rate produced the airplane flight trajectory shown in Figure 3.3.5.2.3 where the elapsed time from take-off to 1.1 stall speed is 20 seconds, during which the airplane travels 1900 feet and climbs 1000 feet. It should be noted that the T/W = 1.2 resulted in limiting the fuel load to 5030 pounds and the combat mission radius of action to 77 miles.

On an Air Force hot day, sea level thrust would be reduced 15 percent and fuel load 63 percent. Retention of the T/W = 1.2 precluded doing any practical mission. Assisted take-off was suggested by Temco as a means for overcoming temperature and altitude effects but no specific analysis was made of this approach.

With regard to landing, a variety of maneuvers was investigated, a typical one being shown in Figure 3.3.5.2.3. With a steady pitching rate of 3 degrees/second and a 10 feet/second sinking speed the airplane passes through stall 4800 feet from the landing pad at 400 feet altitude and finishes the maneuver with a vertical let down from a 50 foot height. Total elapsed time to touchdown is 40 second.

Features of Temco Model 39: The airframe was to be built using conventional practices and structural materials -- aluminum alloy in fuselage, wings and tail; stainless steel where necessary in the engine area. As is evident from Figure 3.3.5.2.4, the inboard profile, the fuselage was designed to have the shortest length compatible with containing the engine, tailpipe, inlet ducting, cockpit and various items of equipment. Forebody length was determined by the nose cone designed to serve as the inlet spike in supersonic flight. The segment of fuselage length between the underbelly inlet and engine face was established by the length of ducting necessary to turn the air into the engine efficiently and to separate the air into that going to the basic engine and that to the turbofan. Fuselage diameter was determined by the maximum diameter of the turbofan plus allowance for cooling and structure.

### TIME HISTORY OF A VERTICAL TAKE-OFF TRAJECTORY

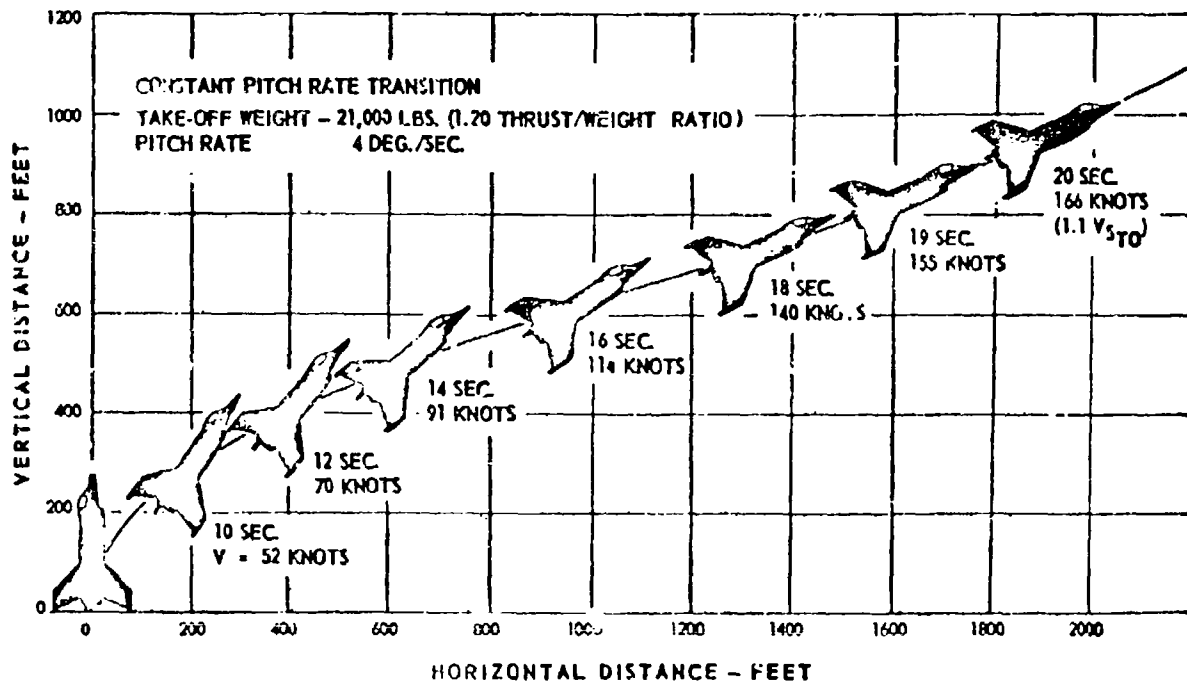

### TIME HISTORY OF A VERTICAL LANDING TRAJECTORY

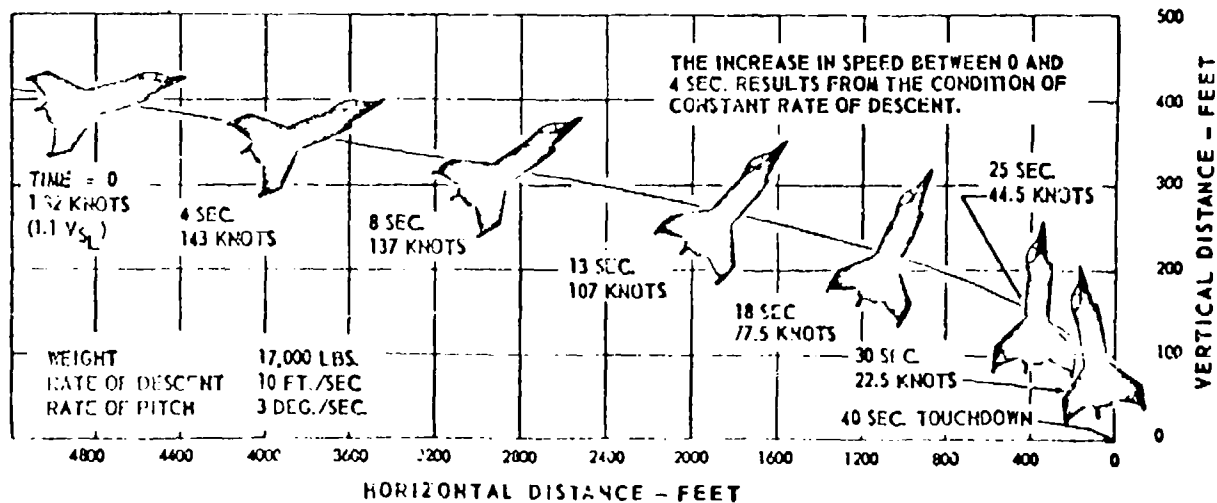

Figure 3.3.5.2.3 Time History of Take-Off and Landing for Temco Model 39 (Courtesy LTV Aerospace)

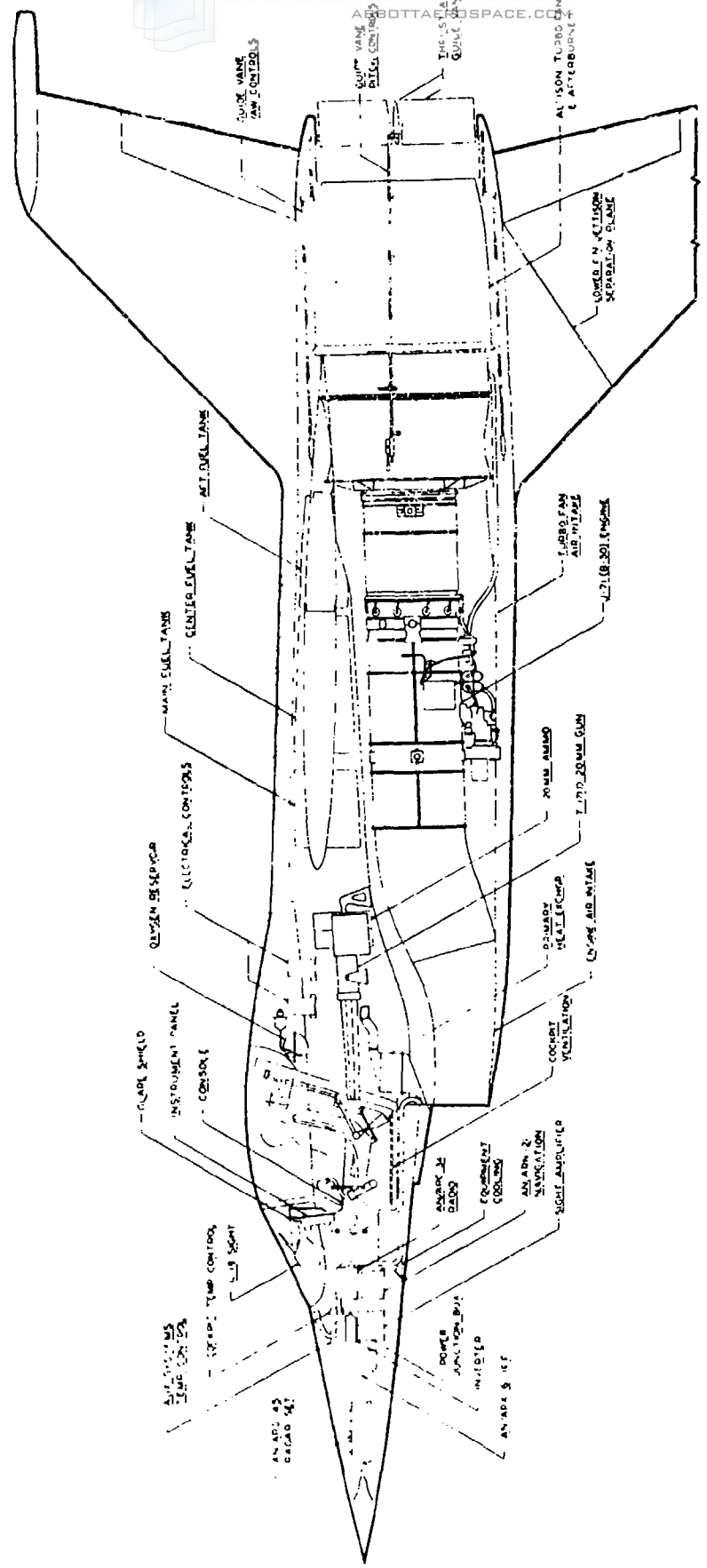

Figure 3.3.5.2.4 Inboard Profile Temco Model 39  
(Courtesy LTV Aerospace)

The cockpit was well forward on the fuselage placing the pilot almost directly above the inlet. Downward vision for the pilot, with the airplane in vertical attitude, was provided by a large canopy and a tilting seat. Figure 3.3.5.2.5 shows the pilot in conventional seated position and in tilted position.

Tilting was available through a very large angle from any desired position between 12 degrees aft of vertical (line at right angles to longitudinal axis of fuselage) and 59 degrees forward. Vertical adjustment of the seat was available only with seat in flight position. Figure 3.3.5.2.5 includes a sketch showing the pilot's downward vision for landing. The seat was equipped with an upward ejection system that automatically disengaged during vertical attitude flight.

A normal complement of flight, engine and other instruments was installed in the instrument panel. Those instruments essential during low speed and vertical flight were grouped in a small section of the instrument panel (Figure 3.3.5.2.6) which rotated when the seat tilted forward; this action placed these instruments in the most readable position.

The controls in the cockpit for controlling airplane attitude consisted of a stick and rudder bars (Figure 3.3.5.2.5). The axis of lateral motion of the control stick was inclined 30 degrees with respect to the airplane's longitudinal axis to permit the pilot to more readily grip the stick when in forward tilt position. The rudder bars were used only when the pilot was near to and in conventional flight position.

The stick caused movement of the elevons in a conventional way -- fore and aft stick motion produced longitudinal control and sidewise motion produced roll control during conventional mode flight. In vertical through transition flight, fore and aft stick motion turned the pitch control vane to deflect the engine exhaust; sidewise stick motion turned the yaw control vane; rolling motion was obtained by twisting the control stick grip. This action controlled the flow from jet reaction nozzles at the wing tips through an electrically-controlled, pneumatically-activated system. The vanes were immobilized and locked in neutral position during conventional mode flight. At take-off the control powers (initial angular acceleration, in radians/sec.<sup>2</sup>) were estimated to be: 0.73 pitch; 0.20 roll; 0.32 yaw.

Elevons, rudders and thrust deflecting vanes were operated by tandem hydraulically-powered servo actuators with stick and rudder bar forces being provided by feel capsules. The system was irreversible to prevent control surface flutter. Means for trimming stick position laterally and longitudinally were incorporated. The twist grip for controlling the wing tip roll producing jets used only a spring centering arrangement and did not incorporate a feel-producing mechanism.

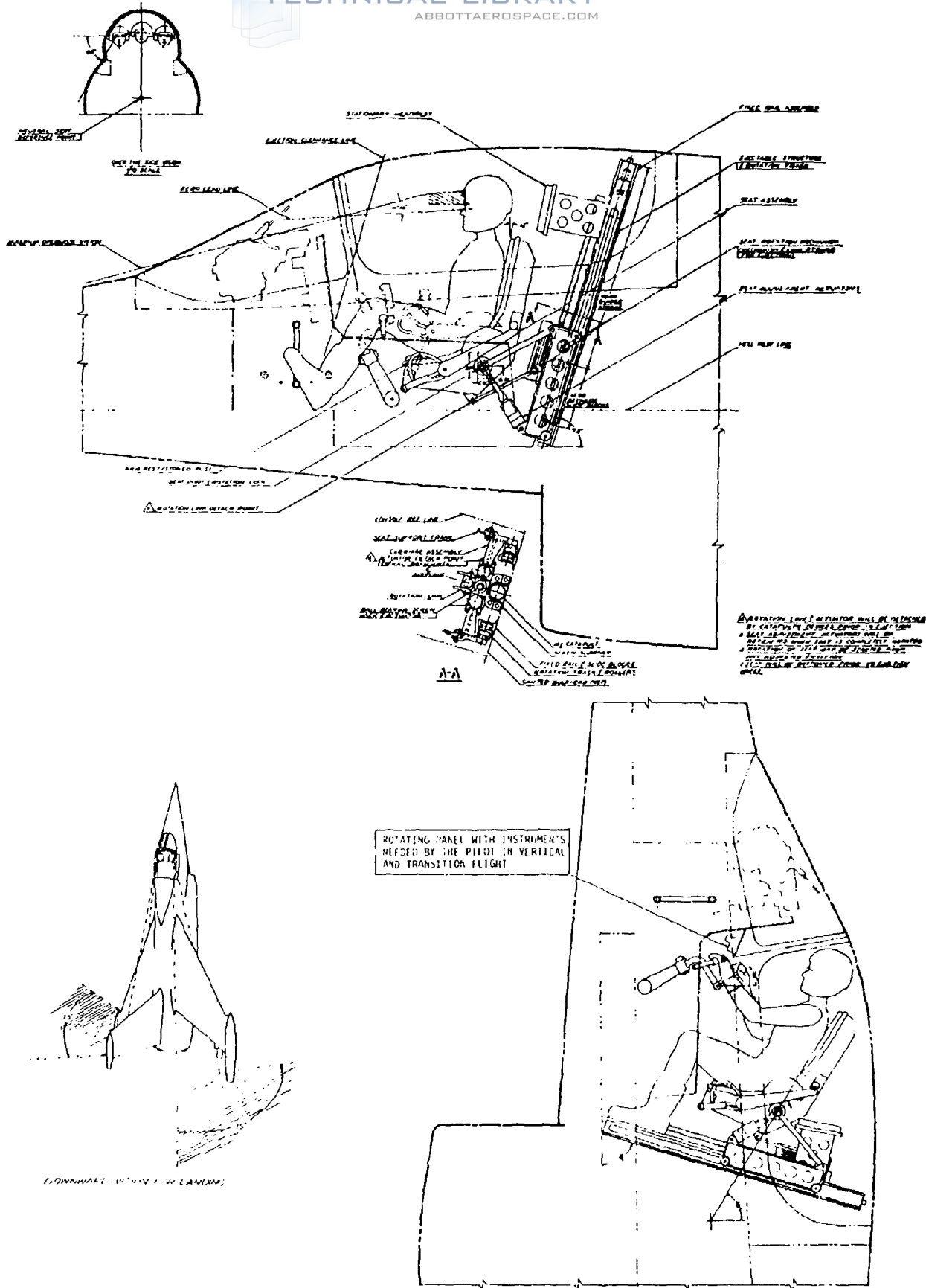

Figure 3.3.5.2.5 Pilot and Seat Positions in Conventional and in Vertical Mode Flight, Temco Model 39 (Courtesy LTV Aerospace)

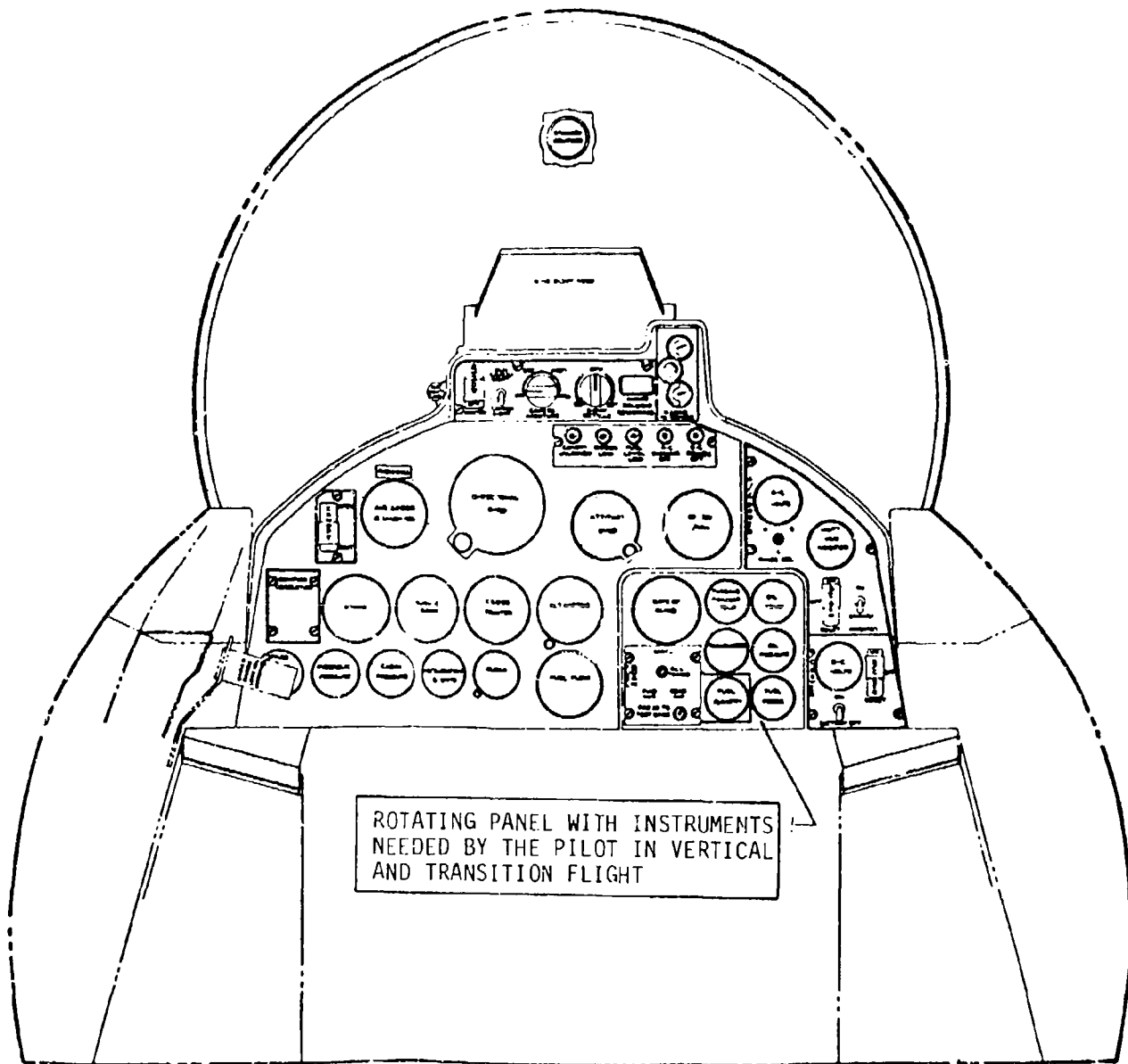

Figure 3.3.5.2.6 Instrument Panel Arrangement Temco Model 39  
(Courtesy LTV Aerospace)

Figures 3.3.5.2.4 and 3.3.5.2.7 show the engine air induction system. The forward underslung inlet served as the common entry for both the turbojet engine and turbofan. Auxiliary air inlet doors (Figure 3.3.5.2.7) were installed immediately aft of the main inlet and were open below speeds of  $M=0.4$  through vertical flight to improve static pressure recovery. The location of the auxiliary doors allowed better mixing of airflow from primary inlet and auxiliary door inlet for pressure equalization. The doors also provided boundary layer suction to reduce separation over the inlet lip. The underslung inlet arrangement favored operation of the VATOL airplane over its 90 degree angle of attack operation.

For supersonic flight, an external diffuser consisting of a three-dimensional spike of approximately 5 degrees, followed by a 5 degree two-dimensional ramp was used to reduce shock loss. A boundary layer bleed system was incorporated into the two-dimensional ramp.

The undercarriage consisted of four shock struts mounted in small diameter pods at the tips of the wing, dorsal and ventral fins. Fixed skid shoes were attached to the shock strut ends. The shoes were elliptically-shaped with a large radius on the contact surface so that, at full gross weight, the unit pressure on the ground was under 140 pounds per sq. in. After absorbing landing shock, the shock struts (oleos) settled to fully bottomed position. This reduced the height of the airplane center of gravity above the ground. After take-off the shock struts and pod fairings extended to full stroke. When needed, ground mobility in vertical attitude was to be provided through use of detachable wheels.

Take-off and landing in a 20 Kt. wind was a requirement. Take-off was not considered to be a problem. In landing, tilting of the airplane into the wind before touch-down eliminated drift and allowed satisfactory landing. According to Temco when drift speed exceeded about 12 Kt. on the ground the airplane would experience a skipping motion and then upset. Temco did not discuss, in Reference 3.3.5.2, the design of the undercarriage which tilted the airplane into the wind before take-off.

The jettisonable ventral fin is shown in Figure 3.3.5.2.4. Fin jettison was through a cartridge activated system and was incorporated to improve safety during an emergency belly landing in forward flight.

Armament for the combat mission was to be a 20 mm Gatling type gun (Figure 3.3.5.2.4) with 800 rounds of ammunition. The gun was located in the fuselage near the left side and aft of the pilot. Major components of the electronics system were installed in the airplane's nose.



Temco's analysis of the airplane's stability in hovering and transition mode flight was brief because of contractual time restraints. They found that, in hovering flight, the vehicle's motion had almost the same frequency and amplitude as a 5,000 pound helicopter. Basically, the pitching mode was divergent but the amplitude increased slowly and was considered to be easily controllable. Stability in transition mode flight was not analyzed but Temco believed that the vehicle could be handled because adequate control had been provided.

With regard to conventional mode flight, longitudinal static stability margin was reasonable in the subsonic speed range and was not excessive at supersonic speeds. Because of the zero geometric dihedral, large angle of wing sweepback and large ventral fin the airplane had an unusual variation of effective dihedral as a function of speed. Effective dihedral had a large positive value at high lift coefficients in the subsonic speed range and approached zero at high subsonic speeds. This was considered to be an acceptable compromise since the airplane had desirable longitudinal stability characteristics over a major portion of its flight range. No detailed calculations of dynamic stability were made due to lack of information on stability derivatives. Lateral-directional stability information was not presented in Reference 3.3.5.2 but rudder control exceeded military specification requirements (Specification MIL-C-5011A) mainly because of the large rudder area provided by the dorsal and ventral tail surfaces. The ailerons provided 220 degree-per-second roll rate in subsonic flight approaching Mach=1.0. As Mach number increased above 1.0, available roll rate decreased to about 150 degrees per second and then rose toward 220 degrees per second as Mach=2.0 was approached. These rates were at all times near the maximum required values.

Consideration was given to using the thrust deflecting vanes to assist in providing longitudinal control in conventional mode flight. It was found that, over the level flight speed range, the vanes gave only a 10 percent gain) in longitudinal control. Because of this and to avoid excessive stability and trim changes arising from variations in power setting, the vanes were locked in the most advantageous position in conventional mode flight.

Regarding the vanes themselves, Temco believed that materials already were available which would permit the vanes to operate in the afterburning jet exhaust without air or liquid cooling. It was proposed that high temperature steel with special enamel, refractory cement coating or a cast refractory material be used. Deflection of each vane was by dual actuators, one at each end, to reduce twisting load on the vane.

The wing, shown in Figure 3.3.5.2.1, was of the sharply swept back type with a leading edge sweep of 57.6 degrees. The planform of the wing was established largely by VATOL considerations. The wing planform was determined by the following needs:

- a) To bring the wing tips far enough back to keep undercarriage leg length reasonable.
- b) To maintain the mean aerodynamic chord far enough forward for longitudinal balance of the airplane.
- c) To have the root chord far enough forward so that the rear spar carry-through structure passed ahead of the engine's fan section.

The tip chord and wing span were established by the undercarriage-geometry and the wing area was a compromise between a small area for light weight and larger area for increased ground stability of the airplane. A 6 percent thick symmetrical airfoil section was selected. The use of a symmetrical section avoided abrupt transonic trim changes often associated with camber and minimized trim loads by avoiding pitching moment at zero lift coefficient. The 6 percent thickness was to minimize buffeting which would become increasingly serious with thicker sections. The airfoil section had a relatively large leading edge radius and large trailing edge angle consistent with good high speed characteristics. This airfoil shape was also a structurally efficient (light weight) section and also tended to reduce flow separation and elevon hinge moments. A retractible leading edge extension on the outboard 50 percent of the wing span was provided for use during transition flight to improve stall behavior. A major consideration in this wing design was to have sufficient torsional stiffness to maintain control effectiveness and prevent flutter at high mach numbers.

The vertical tails followed conventional design and structural practices except that the predominant design factor was the concentrated landing loads applied at the tips of the fins.

Temco's conclusions and recommendations  
were:

Conclusions:

1. A VTOL Day Fighter type airplane using an engine of the J-71 turbofan type appeared to be feasible.
2. The combat mission radius of action for the Model 39 design was only 77 miles. This low distance was attributable to: a) the high T/W (1.2) selected which made

reduced fuel load necessary; b) the relatively high specific fuel consumption of the J 71 turbofan modified engine during cruise and loiter; c) the relatively high airplane drag in cruise flight, d) the unrealistic amount of loiter time (20 minutes).

3. A T/W = 1.085 was theoretically acceptable for take-off and would have increased fuel available for the mission and increased the radius of action.

4. The T-71 plus turbofan engine was mismatched with the given specific airplane performance requirements. An engine with better characteristics (different bypass ratio) was possible and should be selected to meet the specific performance requirements of the VTOL airplane.

5. A fast take-off and transition maneuver (at high pitching rate) involving angles of attack above stall appeared to be satisfactory and required minimum expenditure of fuel for transition to conventional mode flight and minimum time exposure to the consequence of engine failure during the critical period of non-aerodynamic flight.

6. Maximum speed, altitude and rate of climb were exceptionally high for a fighter. This was due to the high T/W available.

7. Use of vanes in the jet exhaust for pitch and yaw control in low-speed and vertical flight appeared to be feasible.

8. Landings in winds up to 20 Kts. could be safely accomplished. Effect of gusts on take off did not appear to be serious.

9. The use of a tilting seat (up to 72 degrees total) and a wide canopy appeared to provide acceptable pilot vision and orientation for VATOL aircraft.

10. The four-point undercarriage was stable, had low unit ground pressure and did not apply undue loads to the supporting structure.

11. The structural problems of a VATOL airplane did not appear to be excessively complicated.

12. The requirement of five minutes combat time was unrealistically low.

Recommendations: Since feasible solutions existed to the various problems revealed by the study, Temco recommended that, before reaching any final decision on the merits of the Model 39 design, the following additional efforts be made:

1. Do an intensive study of the canard configuration to establish its possibilities in a VATOL design.
2. Do a more detailed investigation of alternate duct and inlet configurations including rounded lips, separate inlets for engine and fan and to determine the best size, shape and location for auxiliary air doors.
3. Consider turbofan engines with bypass ratios other than that of the J-71 turbofan system aimed at improving loiter, cruise, low supersonic speed engine performance, and matching the aircraft needs better.
4. Investigate proposed materials for use in the thrust deflecting vanes to determine their ability to withstand vibration and high temperature under load.
5. Refine take-off and landing transition analysis to include experimentally-determined aerodynamic data.
6. Investigate the merit of an adjustable undercarriage designed to tilt the airplane into the wind to eliminate initial drift over the ground during take-off.
7. Analyze the dynamic stability of the airplane using experimentally determined derivatives.
8. Change the combat mission to exploit the VTOL aspects of the fighter. Specifically, use a rational combat maneuver and a reasonable loiter time.
9. Investigate the suitability of projected engines. If found suitable early development of VTOL airplanes could become a reality (statement made in June 1954).

Concluding Observations:

1. To satisfy the Air Force requirement stipulated for this study -- that the VTOL Day Fighter be able to take off and land without auxiliary ground equipment, Temco chose a tail sitter approach. Both the Air Force and Temco apparently did not recognize the fact that a tail sitter does require ground equipment for such functions as: exhaust blast protection and for lowering the airplane to near horizontal attitude for maintenance, support, movement and transportation. Such equipment must be included in a study of VTOL aircraft otherwise the study is incomplete. Lockheed (Section 3.3.5.4) and Ryan Aeronautical (Section 3.3.5.5) both concluded that such ground equipment would be more complex and heavier than that needed for hanging type VATOL airplanes.
2. The selection of a tailless configuration with a sharply swept wing, appears logical, but raises unanswered questions concerning behavior of the airplane during

transition flight, particularly when passing through stall, and the aerodynamic efficiency of the resulting tailless airplane design. Temco recognized the stall problem and incorporated a leading edge device to alleviate it, but did not really address the problem. NASA model tests on other configurations showed that a problem did exist in transition flight. Temco also recognized the structural problem of wing torsion and flutter but did not consider the alternative planform of a delta wing (e.g. Convair's design, Section 3.3.5.3) as a possible solution.

3. Comparison of Temco's Model 39 with Convair's Configuration IVA (Section 3.3.5.3) is revealing. Both used the same engine and were designed to the same mission requirements, yet the Convair design had an estimated 250 n.m. radius of action; Temco's was 77 n.m. The difference in take-off T/W (1.12 for Convair and 1.2 for Temco) does not explain the large difference in radius of action. Furthermore, the Convair design had higher empty and combat weights.

4. Temco placed much importance on the rapidity of completing transition to reduce fuel burned during the take-off-through-transition phase of flight. A T/W of 1.2 was selected as being the highest practical value. Lockheed (Section 3.3.5.4), on the other hand, selected a T/W of 1.01 as being best for mission purposes and airplane sizing. A better yardstick for determining optimum T/W is the fuel remaining for the mission after transition is completed. Temco's approach does not appear to be correct.

5. There was no discussion of "area ruling" in Temco's summary report (Reference 3.3.5.2) and area ruling is not evident in the layout of the airplane (Figure 3.3.5.2.1). If true this is an important deficiency in the design of the airplane.

6. No effort appears to have been put into study and selection of the low speed and vertical flight pitch and yaw control method to be used. The vane approach appears to have been selected arbitrarily, but it is a logical choice. This approach also was selected by Convair and Lockheed (but not by Ryan Aeronautical). Development of the vane system may be more difficult than anticipated by Temco and would require a substantial effort because this control system is a primary safety-of-flight item.

7. Based on Ryan Aeronautical's and SNECMA's experience with VATOL aircraft, a stability augmentation system appears to be necessary. This important feature was not discussed by Temco. It is highly probable that a modern VATOL airplane would have an automatic flight control system for use in VTOL, transition and conventional mode flight.

8. Temco incorporated a total seat tilt of 72 degrees (61 degrees forward tilt). Considering that the XFY-1, XFV-1 and X-13 tail sitters had 30 degree or less forward tilt, the need for Temco's large tilt is questionable. Further, the inability of the pilot to eject from the airplane with seat tilted forward is probably unacceptable.

9. Because of the large angular tilt of the pilot during VTOL and transition flight, the conventional rudder bars and pilot's feet were not used. The cockpit control functions were changed so that lateral stick movement controlled yaw, not roll, and twisting of the stick grip produced roll. Pilot reaction to this system, particularly during transition flight, would have to be resolved. Certainly, extra training of the pilot would be necessary. If much lower seat tilting was used, this special control system might not have been necessary. The X-13 was flown with conventional cockpit controls in all flight modes.

10. Regarding the question of landing with drift, further investigation would be needed to determine if landing with little or no drift is realistic, or to establish how much drift must be considered in the aircraft design. Also, the ground surface (hard or soft) must be defined since this will affect drift tolerance.

11. Although not incorporated into the Model 39 undercarriage Temco recognized the need to have an airplane tilting capability to permit take-off in wind. The Air Force requirement called for operation in up to 20 Kt winds. This is probably too low to cover the operating capability needed in combat operations. Beyond this the tilting undercarriage should be able to handle ground with some slope. Unless the airplane could be turned to "face" the wind while resting on the ground in VTO position the undercarriage would have to be of the omni-directional-tilting type.

12. Although Temco did recognize that jet blast impingement on the ground would cause problems, these were not discussed. The affects and problems due to exhaust impingement on the ground is an essential consideration for the aircraft system. Problems can be expected from the impact of the jet on concrete (spalling), serious tearing up of soil and asphalt under the airplane with potential damage to the vehicle and hazard to bystanders and nearby equipment. Other airframe problems due to vibration and heat from the jet's reaction with the ground and airframe also are important design considerations.

### 3.3.5.3 Convair Design Study (1953-1954)

Convair (Consolidated Vultee Aircraft Corporation), one of the four companies directly participating in the Air Force investigation into VTOL Light Weight Fighter possibilities, received its contract in December 1953. The company carried out preliminary design studies of a tail sitter VTOL type aircraft to determine the most reasonable configuration and size to perform the mission defined by the Air Force.

Reference 3.3.5.3 summarizes the studies and covers its results. The studies were based on using the Allison J-71A (Series 600-B30) turbojet engine, gas coupled to a turbo-fan unit, described by the Wright Air Development Center in WADC Technical Note No. WCOWP 53-5, June 1953. For airplane sizing a thrust/weight (T/W) of 1.1 was selected as a reasonable value to permit transition to conventional mode flight from VTO (S.L., standard day) with acceptable fuel burn and time to climb to altitude. For constant altitude transition "push-over" rates were calculated to be 3 degrees/second for 1.05 T/W and 15 degrees/second for 1.25 T/W, the higher value being more desirable. The 1.1 value was selected as being more realistic with the 26,600 lb installed engine thrust available before bleed air extraction. Additional thrust from rockets (RATO) was proposed for hot day and/or higher altitude VTO.

Three basic design configurations were developed during the study: (I) pilot seated in normal manner in a conventionally-located cockpit; (II) pilot in prone position; (III) pilot seated in normal manner but with cockpit submerged in the air inlet duct. All used a 60° "delta" wing planform but the wing areas differed.

After analyzing each of the designs, Convair concluded that configuration I was the best approach and a final configuration, designated IV, was designed making use of features generated in the other designs. Configuration IVa (Figure 3.3.5.3.1) was an optimization of IV done under an extension of the original contract (Change Order C2 dated 1 May 1954).

Configuration IVa easily met the VTOL, high speed Light Weight Day Fighter requirements using the Allison J-71A turbo fan arrangement prescribed by the Air Force.

Table 3.3.5.3.1 summarizes the performance. The design exceeded all of the performance requirements, most by substantial margins.

Characteristics of the design are presented in Table 3.3.5.3.2.

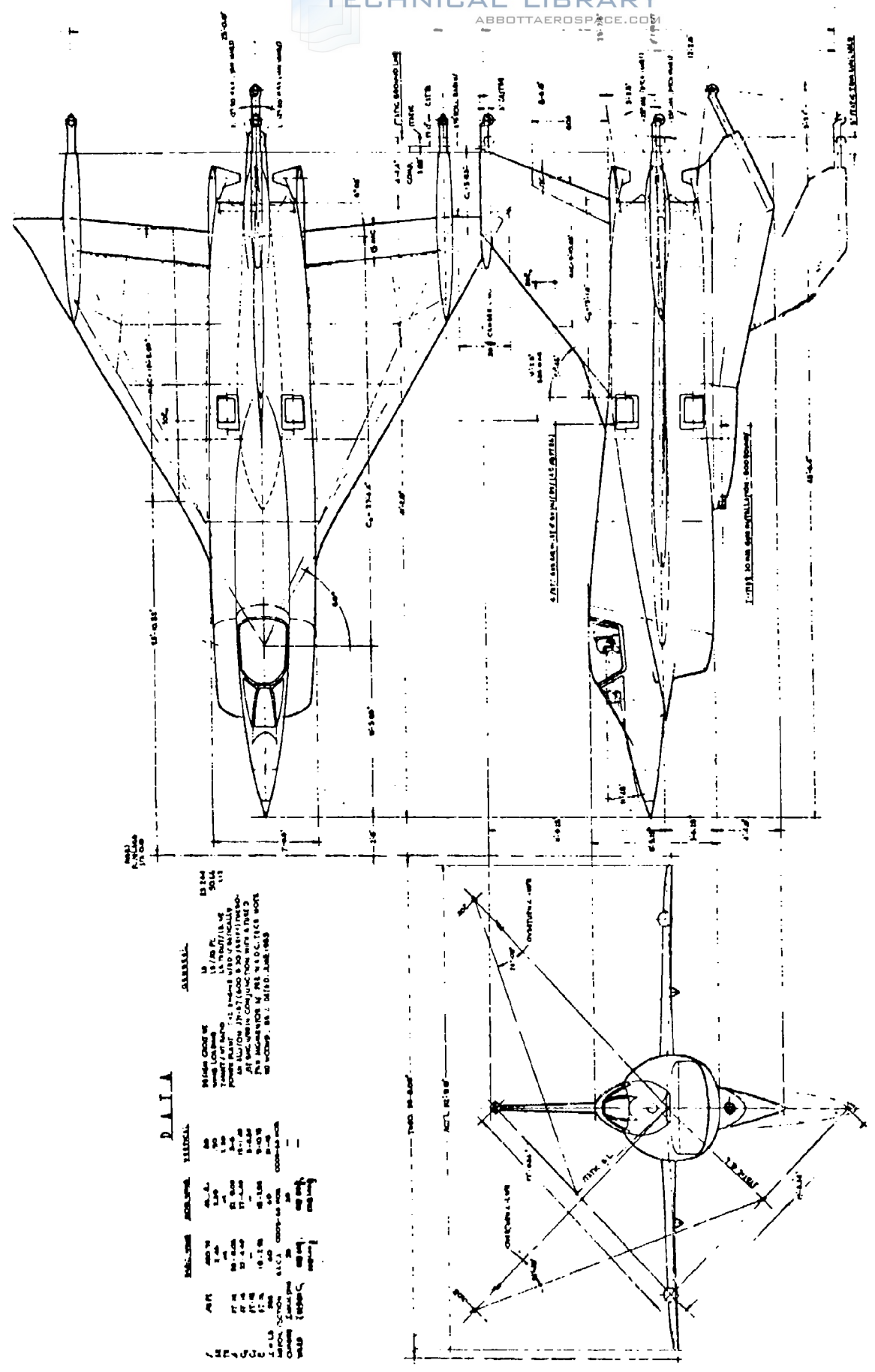

**DATA**

**GENERAL:**

**Model:** VAPOL Configuration IVA

**Scale:** 1/8" = 1'-0"

**Date:** 10/10/64

**Drawn by:** [Name]

**Checked by:** [Name]

**Approved by:** [Name]

**Notes:**

1. THIS DRAWING IS A PRELIMINARY DRAWING. IT IS SUBJECT TO CHANGE WITHOUT NOTICE.

2. ALL DIMENSIONS ARE IN INCHES UNLESS OTHERWISE SPECIFIED.

3. FINISHES TO BE SPECIFIED ON DRAWING.

4. MATERIALS TO BE SPECIFIED ON DRAWING.

5. WEIGHTS TO BE SPECIFIED ON DRAWING.

Figure 3.3.5.3.1 Convair VAPOL Configuration IVA (Courtesy General Dynamics Corporation)

**PERFORMANCE SUMMARY CONVAIR CONFIGURATION IVa**

		<u>Requirement</u>	<u>Convaair Config. IVa</u>
At 35,000 ft. at Combat Wt.	Lbs.	—	20,884
Max. Speed at Max. Power,	Mach	1.6	2.0*
Accel. from Max. Speed (Mil. Power) to Max Speed (M=1.6) at 1.2 g	Min.	3.0**	0.75*
Max. Speed, Mil. Power	Mach	—	0.93
Combat Radius, For $M_{\text{Combat}} = 1.3$	n.m.	—	250
Combat Altitude,	Ft.	50,000	50,000
Service Ceiling (100 fpm R/C), Mil. Power	ft.	45,000	48,500
Service Ceiling (100 fpm R/C), Combat Power	Ft.	—	65,500
Normal Acceleration, Steady Turn at 45,000 Ft.		1.5g at M=0.95 1.5g at M=1.65	2.0g 2.65g
Max. R/C, S.L., T.O. Wt., Mil Power,	FPM	—	12,600
Max. R/C, 35,000 Ft., Mil Power	FPM	—	4350
Max. Speed, S.L., Max. Power	Mach	—	1.0*

\* Engine Limit  
 \*\* Speed reached in 3.0 minutes is 2.0

**TABLE 3.3.5.3.2**

**CHARACTERISTICS OF CONVAIR CONFIGURATION IVa**

Engine	Allison J-71 (B-30) with turbofan
*Rated Thrust,	26,600 lbs.
*Net Thrust,	25,568 lbs.
Empty Weight,	16,058 lbs.
Weight, Zero Fuel,	17,343 lbs.
Combat Weight,	20,884 lbs.
Useful Load,	7,186 lbs.
*Combat Mission T.O. Weight,	23,244 lbs.
*Combat Mission Fuel Weight,	5,901 lbs.
*Take Off T/W	1.1
Span,	32'9"
Length,	45' 6.4"
Distance Wheel-to-Wheel, at Vert. Tail,	25'7.6"
Wing Area,	459 sq. ft.
Wing Loading at Combat Wt.,	45.5 lbs. sq. ft.

\*S.L. Std. Day conditions

In addition to the values given in Table 3.3.5.1 for speed and combat ceiling, this aircraft could:

Take-Off and reach 124 Kt stall speed in 18 sec and 1600 ft distance (T/W = 1.1, Pitch over rate 3.6°/sec, Constant altitude)

From a 124 Kt stall speed decelerate and land in 20 sec and 2400 ft distance (Constant altitude)

Climb to 45,000 ft cruise altitude in 8.9 min (T.O. rate of climb 12,600 fpm)

Combat climb 16,380 fpm at 50,000 ft (Combat wt 20,844 lb)

Recognizing the basic importance of the system used to provide vertical mode/low speed flight control Convair examined six concepts for such control. All were based on deflection of exhaust flow for pitch and yaw control and using cold thrust at the wing tips for roll. Air for the roll control jets was obtained by bleeding the engine compressor resulting in a 2.4 percent thrust loss. The controls were to be such as to permit hovering in a steady 20 Kt wind from any direction, plus gusts of 20 Kt additional. Nose-up control power was to be sufficient to permit constant altitude landing transition with an average longitudinal deceleration of 15 ft/sec<sup>2</sup>.

Six pitch and yaw control concepts were considered of which two were judged to be the most promising -- non-retracting flow deflector vanes in the exhaust and nozzle swivelling. The latter was believed to require long development time and enlarged fuselage diameter in the afterburner region. The non-retracting deflector vane system, Figure 3.3.5.3.2, was chosen because it was judged to be practical and simple, to cause minimum thrust loss and could be developed early. Cooling and long service life were recognized as main development problems. Use of the vanes as roll moment generators was considered to be a possibility. This was of interest because, by eliminating the wing tip reaction jets, increased vertical lift (engine thrust) becomes available. This approach was not used in the Convair designs however.

The description of the vane control system given in Figure 3.3.5.3.2 reveals that the vanes would be exposed to 3000°R afterburner gas flows during take off, climb, combat and landing. Total exposure time was expected to be approximately six minutes. During non-afterburning operation the reduction in jet stream diameter placed the vanes practically outside of the stream, exposing them to only 800° to 900°R temperature. Use of heat resistant materials such as carbon and alumina were proposed for the vane surfaces to handle the high temperature operation.

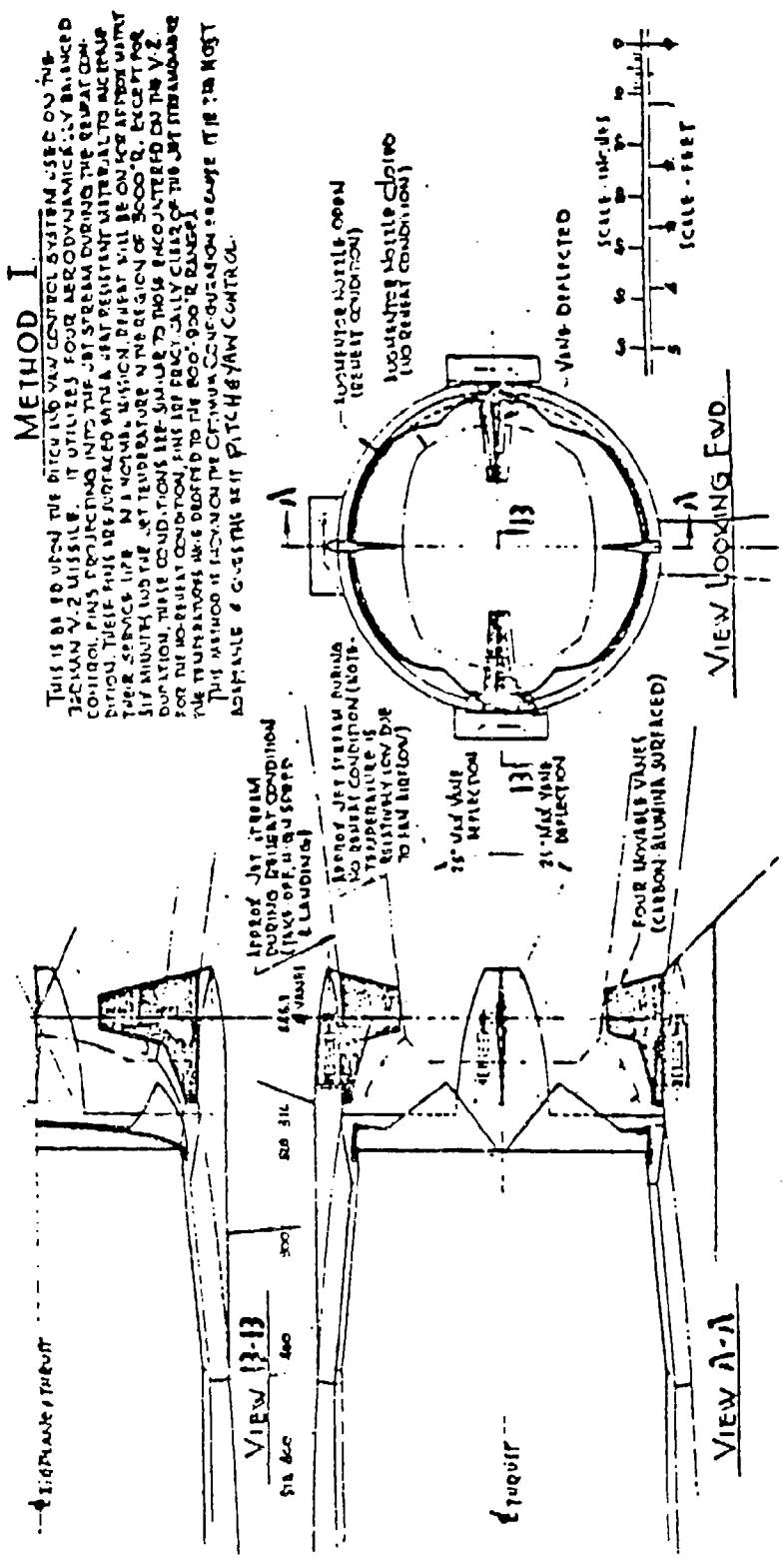

Figure 3.3.5.3.2 Control Method Selected by Convair for VATOL Light Weight Day Fighter (Courtesy General Dynamics Corporation)

Features of Configuration IVa: The airframe was to be constructed using conventional techniques. Aluminum alloy was to be the basic material with steel or Inconel being used locally as-needed in high temperature regions. Weight saving was to be obtained through use of solid honeycomb structure in the vertical tail-fin and machined skins, forged spars and integral fuel tanks in the wings. The undercarriage was to be of the oleo shock strut type with four units attached one near each wing tip, one at the upper fin tip and one in a pivoting ventral structure to form a cruciform ground contact pattern.

Figure 3.3.5.3.3 shows the arrangement of the pivoting ventral boom-like structure. The purpose of this arrangement was to provide a large wheel base and improved ground stability with overturn angles of 24 degrees, without the detrimental effects of a large ventral fin. Replacement of the fin with a retracting ventral structure gave the following benefits:

1. Reduction in lateral-directional divergence during transition flight.
2. Reduction of airframe drag by eliminating ventral fin area.
3. Safer belly landing during an emergency.
4. No increase in installed weight.
5. Ideal location for the gun's ammunition.
6. Providing a drag-reducing fairing for the gun pod, with ventral structure in retracted position.

Small, fully-castoring wheels were attached to the oleo struts which were designed to absorb a 5 ft./sec. sink speed at maximum take-off weight and 9 ft./sec. at landing weight. Strut extension was to be controllable to tilt the airplane as much as 5 degrees, during static rest. Tilt into the prevailing winds minimized drift-back on take-off.

Aerodynamically, the fuselage was optimized for low drag while enveloping the pilot compartment, turbofan engine, inlet ducts and all the required equipment. Development of the body lines was based on use of "area ruling". Figure 3.3.5.3.4, the inboard profile, shows the installation of the J-71 engine, air ducting, variable-area nozzle, control vanes and other details.

The exit nozzle area could be varied as required for take-off, conventional flight and combat. Area variation was obtained through actuation of two sets of eyelids (upper and lower) about a horizontal axis. The control vanes for use in vertical through transition flight were aft of the variable area nozzle and the vanes' location permitted them to

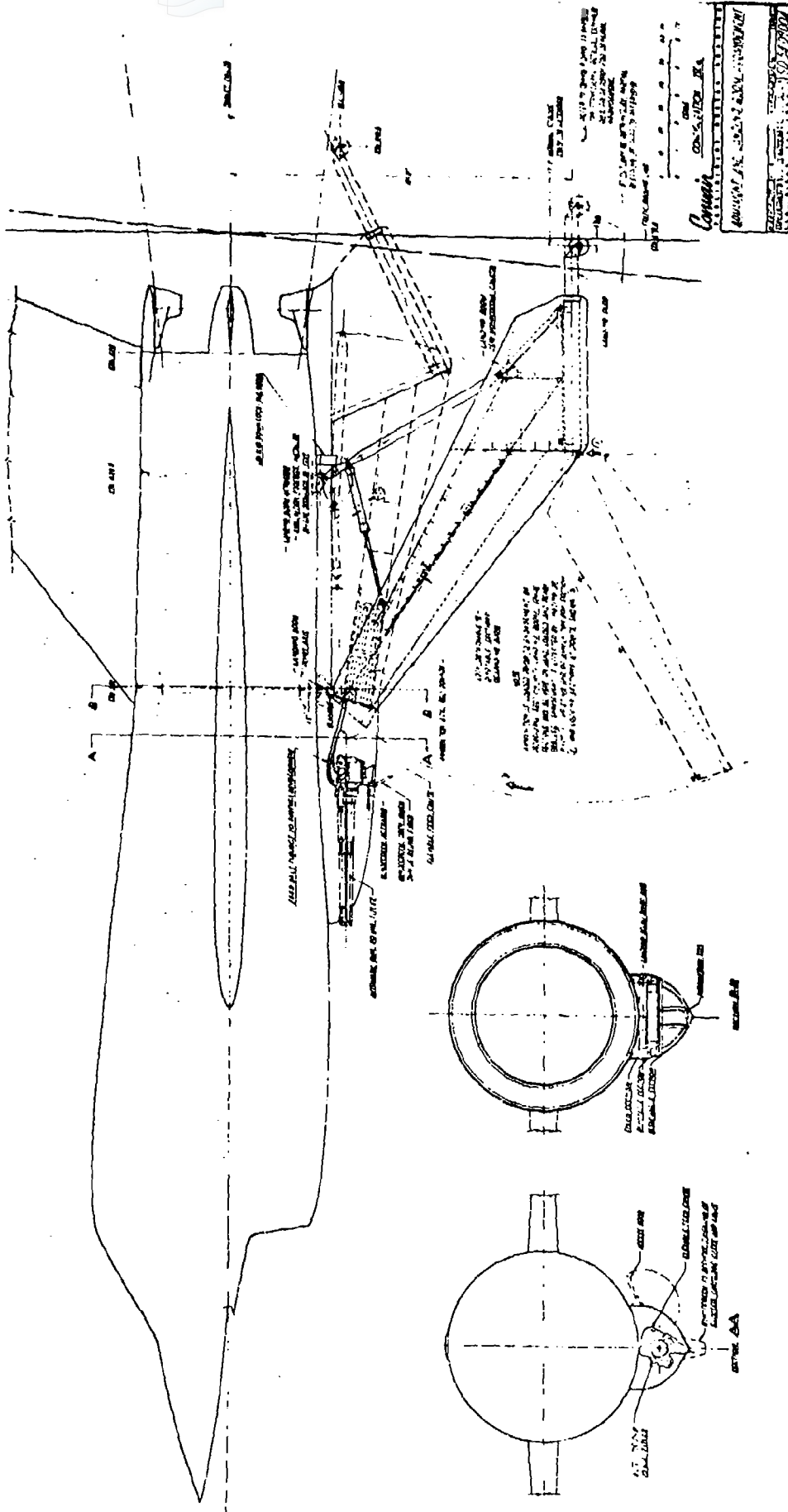

Figure 3.3.5.3.3 Pivoting Ventral Fin and Undercarriage Arrangement  
Convair Configuration IVa (Courtesy General Dynamics Corporation)

1. THE AIRCRAFT IS A...  
 2. THE AIRCRAFT IS A...  
 3. THE AIRCRAFT IS A...  
 4. THE AIRCRAFT IS A...  
 5. THE AIRCRAFT IS A...  
 6. THE AIRCRAFT IS A...  
 7. THE AIRCRAFT IS A...  
 8. THE AIRCRAFT IS A...  
 9. THE AIRCRAFT IS A...  
 10. THE AIRCRAFT IS A...

1. THE AIRCRAFT IS A...  
 2. THE AIRCRAFT IS A...  
 3. THE AIRCRAFT IS A...  
 4. THE AIRCRAFT IS A...  
 5. THE AIRCRAFT IS A...  
 6. THE AIRCRAFT IS A...  
 7. THE AIRCRAFT IS A...  
 8. THE AIRCRAFT IS A...  
 9. THE AIRCRAFT IS A...  
 10. THE AIRCRAFT IS A...

1. THE AIRCRAFT IS A...  
 2. THE AIRCRAFT IS A...  
 3. THE AIRCRAFT IS A...  
 4. THE AIRCRAFT IS A...  
 5. THE AIRCRAFT IS A...  
 6. THE AIRCRAFT IS A...  
 7. THE AIRCRAFT IS A...  
 8. THE AIRCRAFT IS A...  
 9. THE AIRCRAFT IS A...  
 10. THE AIRCRAFT IS A...

1. THE AIRCRAFT IS A...  
 2. THE AIRCRAFT IS A...  
 3. THE AIRCRAFT IS A...  
 4. THE AIRCRAFT IS A...  
 5. THE AIRCRAFT IS A...  
 6. THE AIRCRAFT IS A...  
 7. THE AIRCRAFT IS A...  
 8. THE AIRCRAFT IS A...  
 9. THE AIRCRAFT IS A...  
 10. THE AIRCRAFT IS A...

1. THE AIRCRAFT IS A...  
 2. THE AIRCRAFT IS A...  
 3. THE AIRCRAFT IS A...  
 4. THE AIRCRAFT IS A...  
 5. THE AIRCRAFT IS A...  
 6. THE AIRCRAFT IS A...  
 7. THE AIRCRAFT IS A...  
 8. THE AIRCRAFT IS A...  
 9. THE AIRCRAFT IS A...  
 10. THE AIRCRAFT IS A...

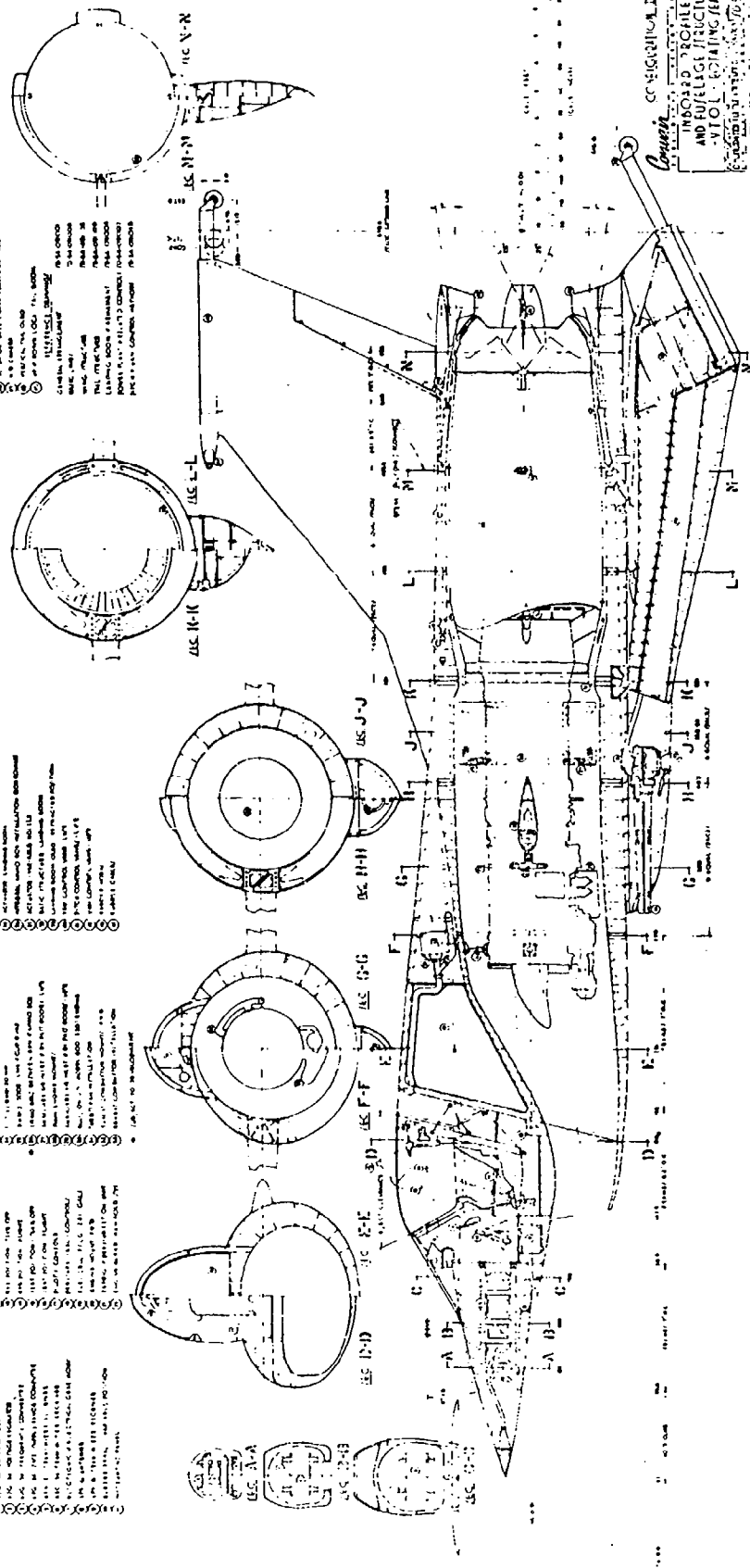

Figure 3.3.5.3.4 Inboard Profile Convair Configuration IVa  
 (Courtesy General Dynamics Corporation)

work within the boundaries of the "cool stream" and the 7 degree expansion gas flow.

The air induction system included a chin-type inlet, a fixed ramp, subsonic diffuser and by-pass doors. Four sets of these doors were spaced around the fuselage section located just forward of the turbofan inlet. The doors were reversible; during vertical and low speed flight they opened to become auxiliary inlets. In supersonic flight they acted as by-pass doors to minimize drag.

A 10 degree ramp angle was selected to give optimum pressure recovery through the external shock system during supersonic acceleration, while a 35 degree lip angle was selected to prevent oblique shock waves from entering the inlet duct at speeds less than Mach = 2.0. Convair's analysis showed that recovery through the external shock system was insensitive to the ramp angle for a broad range of Mach numbers and that the 10 degree ramp gave within 1.0 percent of the best recovery for an oblique plus normal shock wave from M=1.8 down to shock separation at M=1.42.

The pilot's compartment was of the conventional type. However, the seat could rotate through a 40° angle, from 10° aft of a line perpendicular to the fuselage centerline to 30° forward. Emergency upward ejection was to be possible at any seat angle. The cockpit, canopy and tilting seat arrangement was designed to permit the pilot to see the wing tip undercarriage. Convair believed this to be mandatory to insure safety during take-off and landing. During landing the pilot could use his depth perception to judge sink speed if he could see the wing tip undercarriage in relation to the ground.

The wing was a 60 degree Delta type with integrated leading edge camber and warp. The airfoil section, a modified NACA 0005-63, was selected on the basis of weight, best aerodynamic cruise conditions and physical thickness at the undercarriage attachment stations. Wing structure was typical stress skin-multispar construction. The midwing installation was selected because it saved weight and reduced aerodynamic pitching moments.

Fuel was carried in eight compartmented, integral tanks in the wing and tanks in the fuselage.

Wing trailing edge sweep (6 degrees) was used to reduce undercarriage overhang in relation to the static ground line. No wing dihedral was incorporated.

The vertical tail had a 60 degree leading edge sweep and an airfoil section similar to that of the wing. The tail was solid honeycomb-multiframe construction to reduce weight.

On the basis of NACA free-flight tests of a ducted fan model quite similar to the Convair configuration, it was concluded that hovering flight posed no difficulties. In transition flight the longitudinal characteristics appeared good, but directional stability characteristics at an angle of attack of about 55 degrees were poor. These directional stability characteristics could not be improved by increasing vertical tail volume, changing wing-body intersection or by adding a ventral fin. It was expected that a yaw damper would give good directional characteristics.

Only preliminary estimates of the stability characteristics in conventional mode flight ( $M=0.2$  to  $2.85$ ) were made. The results indicated that the large inlet required for the J-71 turbofan had a noticeable destabilizing effect in pitch and yaw at low speeds, making it desirable to design for nearly neutral to slightly positive longitudinal stability at low air speed. This approach would result in reduced trim drag and improved maneuverability at altitude. Artificial damping or stability was considered as a means to provide desired handling characteristics at low speed. Failure of these devices would result in an unsafe airplane.

Convair did not discuss the problems of ground transport, servicing and maintaining the airplane. Nor was there any discussion of ground preparation required for operation of this tail-sitter airplane. When sitting on the ground the exhaust nozzle end was about  $4\frac{1}{3}$  feet from the ground (the nose ended 46 feet above the ground). The undercarriage was designed for landing on hard surfaces but Convair did recommend that studies be made of methods for allowing landing on unprepared surfaces without creating excessive undercarriage side loads.

Convair concluded that it was practicable to design and build a VTOL Light Weight Day Fighter airplane using a turbofan engine (as defined by the Air Force) and that the airplane would weigh approximately 23,000 lb at take-off for the 250 n.m. fighter type mission. They recommended that the turbofan engine be developed to have 35,000 lb S.L. stg. day, static thrust rating instead of the 29,400 lb rating specified by the Air Force. This was to cover hot day - higher altitude operations or increased gross weight for greater combat radius. If the lower thrust rating engine was to be used, JATO would be required to handle hot day, higher altitude take-offs. An additional recommendation made by Convair was that development studies be continued to determine the most practical method of controlling VOTOL aircraft in vertical mode and transition flight.

#### Concluding Observations:

1. Convair elected to study only the tail-sitter type VTOL approach for the Light Weight Day Fighter

and considered only the delta wing configuration. Within these constraints a credible study appears to have been done, but only on the aircraft itself. A serious deficiency in the study was the failure to consider the ground support equipment essential for lowering the airplane to horizontal attitude and maintaining, supporting, moving and transporting it. Such equipment must be included in a study of VTOL aircraft designs. Ryan Aeronautical (Section 3.3.5.5) and Lockheed (Section 3.3.5.4) concluded that such ground support equipment was more complex and heavier than equipment needed for a hanging type VATOL airplane.

2. The problems of operating afterburning jets in close proximity to the ground were not covered in the document issued by Convair. (The jet exit on Configuration IVa was 4-1/3 feet from the ground). The effects and problems due to exhaust impingement on the ground is an essential consideration for the aircraft system. Problems can be expected from the impact of the jet on concrete (spalling), serious tearing up of soil and asphalt under the aircraft with potential damage to the vehicle and hazard to bystanders and ground equipment. Other airframe problems due to vibration and heat from the jet's reaction with the ground and airframe can be serious; these were not covered.

3. The Convair designs had small dolly-like undercarriage wheels and the designers recognized that these were unsatisfactory on soft ground because of side loads when landing with side drift and because the small wheels did not permit moving the airplane over soft ground when necessary. Special handling dollies and jacks for putting them in place would solve the ground mobility problem, but not the side drift one. Possible solutions were not discussed by Convair, however, they did suggest that this be a subject for study in the event of further effort on their designs. Since the solution affects the airplane's empty weight, a suitable landing gear should have been included in the airplane design during the study.

4. The system built into the undercarriage for tilting the airplane on the ground is a good feature and probably would be needed to handle not only wind on take-off but operation on sloping ground. The five degree tilt capability provided may be inadequate for operation from unprepared areas with slope. Tilting should be omnidirectional.

5. Based on the work done by Ryan Aeronautical and SNECMA, a stability augmentation system (SAS) appears to be necessary for VATOL aircraft. Convair did not include SAS in their designs but did recognize the need. It is highly probable that a modern VATOL aircraft would have an automatic flight control system for use in vertical attitude, transition and conventional mode flight.

6. Convair showed very good awareness of the various methods of control in vertical/transition mode flight. Their evaluation of each method was cursorily done because of the limited nature of the contracted study. However, their selection of vanes in the exhaust is logical but development problems may have been underestimated. Convair's suggestion that the vanes could be used for roll control as well as for pitch and yaw is interesting. It could eliminate the need for wing tip jets and bleeding of compressor air. The XBQM-108A (3.3.4) developed in the 1973-1977 time period did use vanes in the exhaust for three-axis control. Thrust vector control of afterburning jets is an important study area for VATOL aircraft and will have to be done if such aircraft are actually considered for development.

7. N.A.C.A. model tests of a configuration generally similar to the Convair Configuration IVa showed the model to have roll divergence above stall angles (Reference 3.3.5.4). This was possibly due to asymmetric stall of the wing. However, the X-13, also of similar configuration, was able to handle transition flight adequately, but it had a stability augmentation system. It appears that more exploratory work on the transition problem of such aircraft configurations is needed to determine the seriousness of the problem and its solutions.

### 3.3.5.4 Lockheed Design Study (1954-1955)

In 1954 Lockheed Aircraft Corporation's California Division received their contract from the Air Force Research and Development Command to "--- conduct general investigations and design studies to determine the optimum aircraft configuration to perform the lightweight day fighter missions ----". Further stated objectives were: (1) to indicate the most favorable power plant utilizing turbojets then under development; (2) to provide a basis for comparing with conventional Day Fighters the overall merit of VTOL Day Fighters using current development turbojets; (3) to identify technical obstacles to the practical development of such a weapon system. In addition, the use of advanced turbojet and turbofan engines was to be investigated to determine if better aircraft would result from the use of these engines and to permit comparisons between turbojet and turbofan for VTOL fighter application. The Lockheed contract was let subsequent to the completion of the six-month-long studies done by Temco and Convair. Lockheed's contract was for a one-year effort.

Lockheed was well aware of the various VTOL approaches which could be used for the Day Fighter. Because of contractual budget limitations and the detail required by the contract's Statement of Work Lockheed restricted their study effort to "airplanes which take off and land with fuselage vertical (VATOL) and maintain thrust axes fixed with respect to the airplane in all flight modes". Previous studies by Lockheed had shown that this approach led to lighter, simpler, high-performance airplanes than those with tilting engines, large angle thrust vectoring or other in-flight configuration changes.

Reference 3.3.5.5, which summarizes the Lockheed effort and its results, shows that the study of VATOL configurations was fairly extensive and that Lockheed had a very good understanding of VATOL aircraft design and problems. Two generic types of VATOL fighter airplanes were investigated: "dependent" aircraft -- those which use a ground located apparatus for take-off and landing; and "independent" aircraft -- those which have an integral undercarriage plus self-contained means for raising and lowering the airplane between horizontal and vertical take-off attitudes.

Lockheed laid out a number of dependent and independent VATOL aircraft designs, from which they selected two basic designs, a cable hanging type designated CL-295-1 (Figure 3.3.5.4.1) and a self-erecting type, CL-295-4 (Figure 3.3.5.4.3). Each used a different engine. The CL-295-1 had one Wright TJC32C4 turbojet engine then under development. The CL-295-4 used two General Electric X-84 advanced turbofan engines, a "paper" engine then under study. This selection was made because, at this stage of the turbofan engine study, the engine could be sized to provide the desired thrust, two engines being preferable to meet the special design requirements

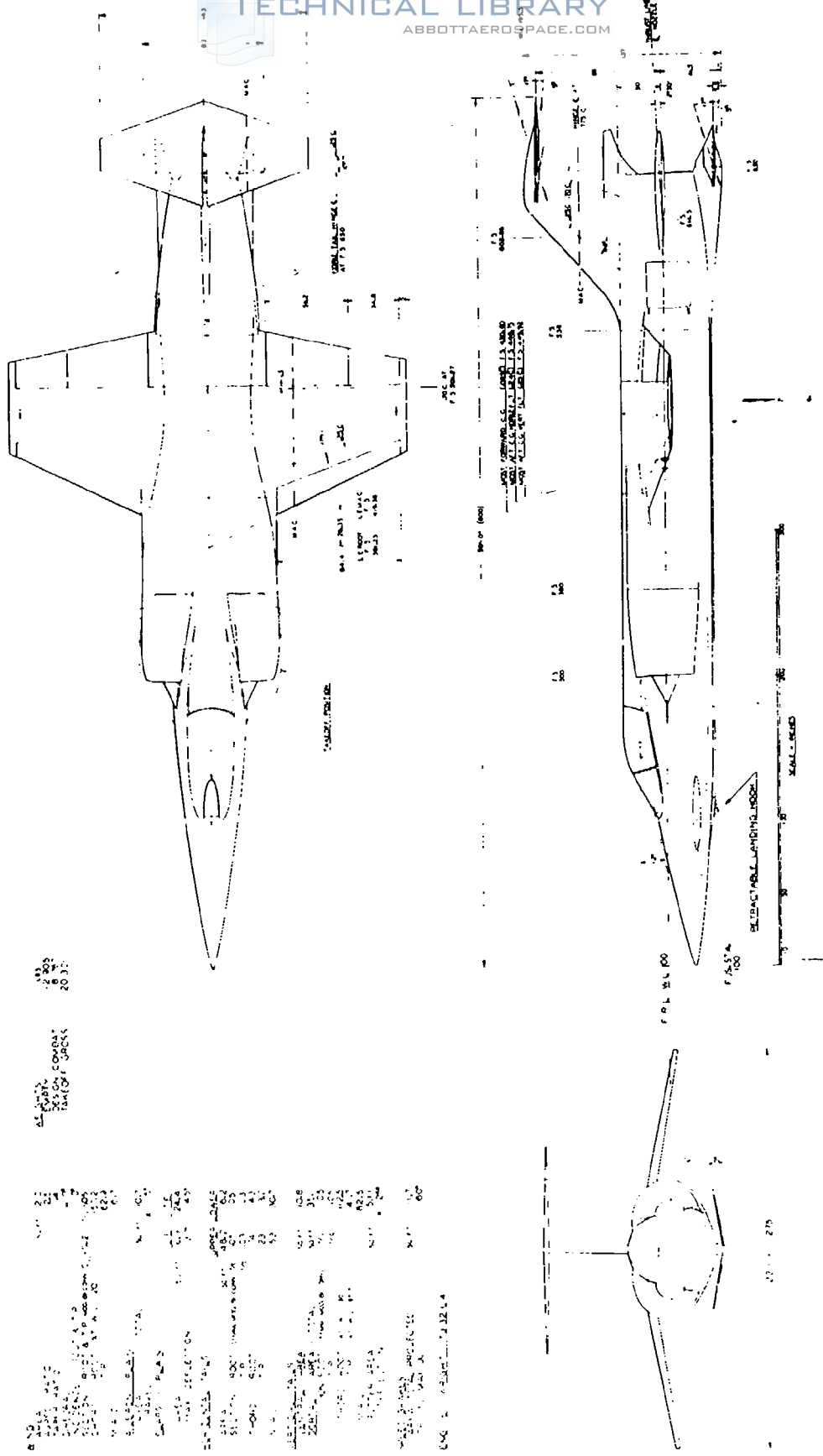

Figure 3.3.5.4.1 General Arrangement, Lockheed CL-295-1 Dependent VATOL Airplane  
 Design with Wright TJC32C4 Turbojet Engine (Courtesy Lockheed Corporation)

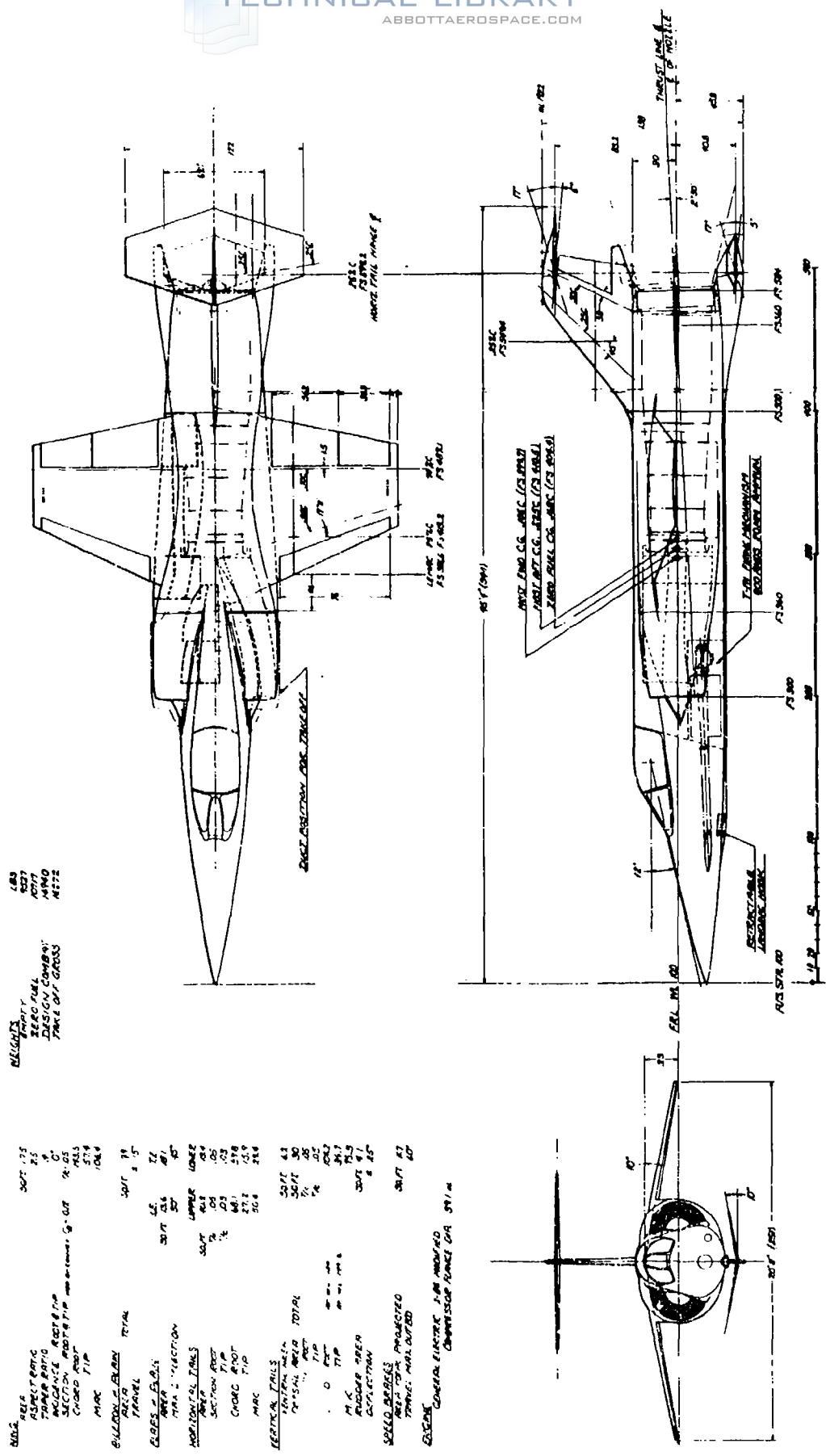

Figure 3.3.5.4.2 General Arrangement, Lockheed CL-295-3 Dependent VATOL Airplane Design with GE X-84 Turbofan Type Engine (Courtesy Lockheed Corporation)

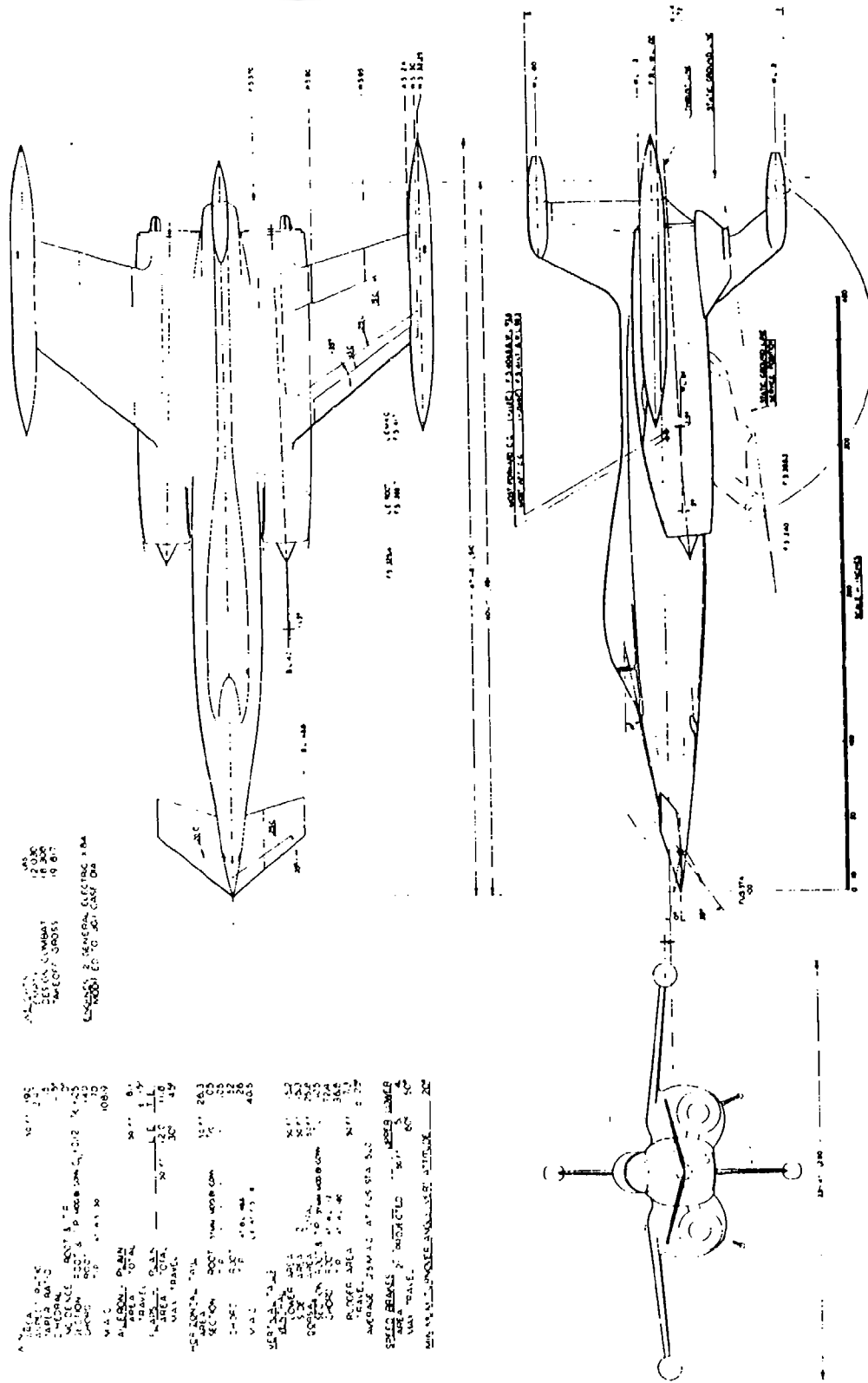
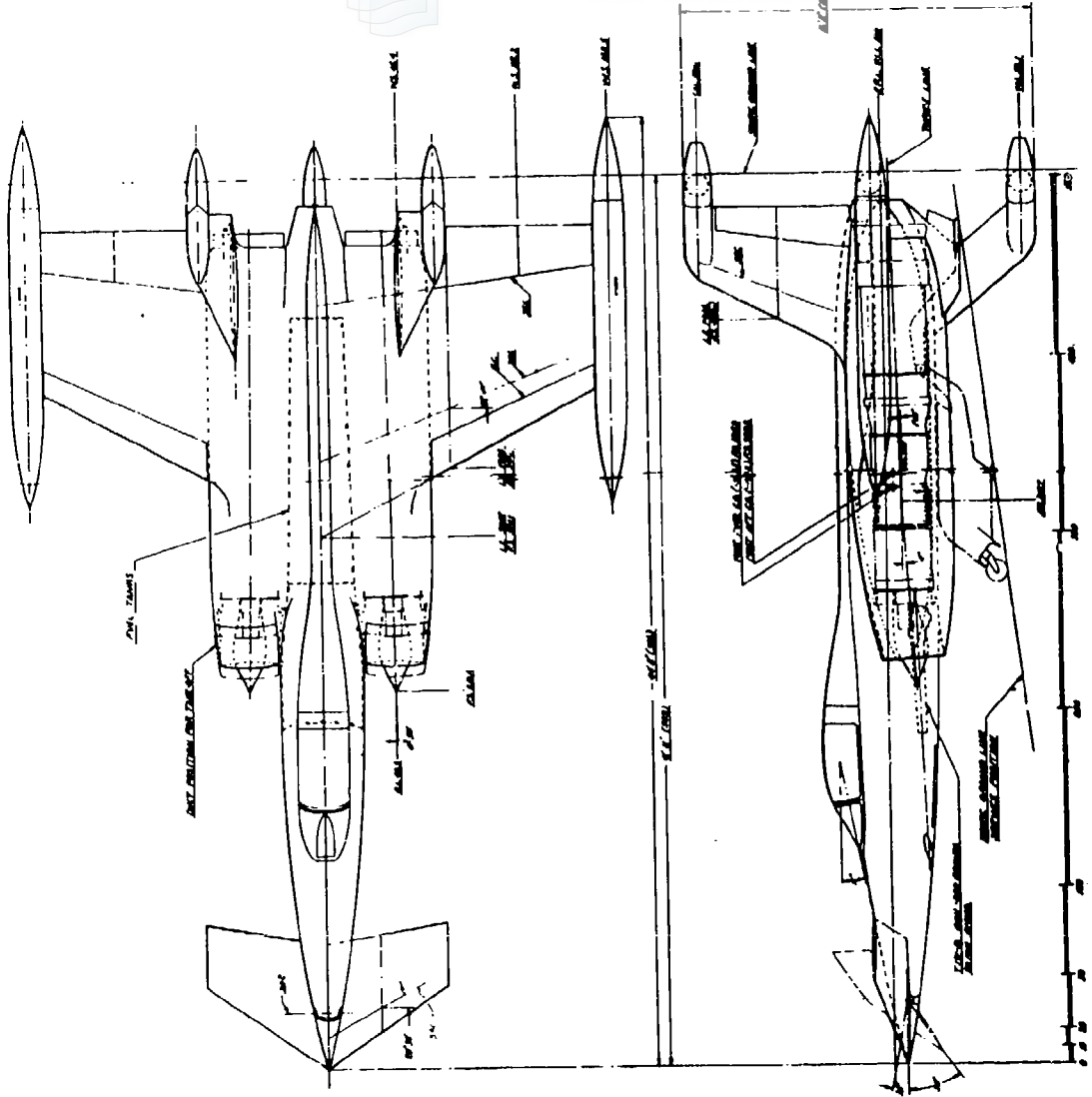

Figure 3.3.5.4.3 General Arrangement Lockheed CL-295-4 Independent VATOL Airplane Design with GE X-84 Engine (Courtesy Lockheed Corporation)



DESIGNER: AEC  
 CONTRACTOR: AEC  
 PROJECT: AEC  
 DRAWING: AEC  
 SCALE: AEC  
 SHEET: AEC  
 TOTAL SHEETS: AEC  
 DATE: AEC  
 BY: AEC  
 CHECKED: AEC  
 APPROVED: AEC  
 REVISIONS: AEC

ITEM	DESCRIPTION	UNIT	VALUE
1	WING AREA	SQ FT	1200
2	WING SPAN	FT	30
3	WING TIP CHORD	FT	10
4	WING ROOT CHORD	FT	10
5	WING MACH		0.5
6	WING TAPER		0.5
7	WING SWEPT	DEG	0
8	WING INC	DEG	0
9	WING TRAIL	FT	0
10	WING AREA	SQ FT	1200
11	WING SPAN	FT	30
12	WING TIP CHORD	FT	10
13	WING ROOT CHORD	FT	10
14	WING MACH		0.5
15	WING TAPER		0.5
16	WING SWEPT	DEG	0
17	WING INC	DEG	0
18	WING TRAIL	FT	0
19	WING AREA	SQ FT	1200
20	WING SPAN	FT	30
21	WING TIP CHORD	FT	10
22	WING ROOT CHORD	FT	10
23	WING MACH		0.5
24	WING TAPER		0.5
25	WING SWEPT	DEG	0
26	WING INC	DEG	0
27	WING TRAIL	FT	0
28	WING AREA	SQ FT	1200
29	WING SPAN	FT	30
30	WING TIP CHORD	FT	10
31	WING ROOT CHORD	FT	10
32	WING MACH		0.5
33	WING TAPER		0.5
34	WING SWEPT	DEG	0
35	WING INC	DEG	0
36	WING TRAIL	FT	0
37	WING AREA	SQ FT	1200
38	WING SPAN	FT	30
39	WING TIP CHORD	FT	10
40	WING ROOT CHORD	FT	10
41	WING MACH		0.5
42	WING TAPER		0.5
43	WING SWEPT	DEG	0
44	WING INC	DEG	0
45	WING TRAIL	FT	0
46	WING AREA	SQ FT	1200
47	WING SPAN	FT	30
48	WING TIP CHORD	FT	10
49	WING ROOT CHORD	FT	10
50	WING MACH		0.5
51	WING TAPER		0.5
52	WING SWEPT	DEG	0
53	WING INC	DEG	0
54	WING TRAIL	FT	0
55	WING AREA	SQ FT	1200
56	WING SPAN	FT	30
57	WING TIP CHORD	FT	10
58	WING ROOT CHORD	FT	10
59	WING MACH		0.5
60	WING TAPER		0.5
61	WING SWEPT	DEG	0
62	WING INC	DEG	0
63	WING TRAIL	FT	0
64	WING AREA	SQ FT	1200
65	WING SPAN	FT	30
66	WING TIP CHORD	FT	10
67	WING ROOT CHORD	FT	10
68	WING MACH		0.5
69	WING TAPER		0.5
70	WING SWEPT	DEG	0
71	WING INC	DEG	0
72	WING TRAIL	FT	0
73	WING AREA	SQ FT	1200
74	WING SPAN	FT	30
75	WING TIP CHORD	FT	10
76	WING ROOT CHORD	FT	10
77	WING MACH		0.5
78	WING TAPER		0.5
79	WING SWEPT	DEG	0
80	WING INC	DEG	0
81	WING TRAIL	FT	0
82	WING AREA	SQ FT	1200
83	WING SPAN	FT	30
84	WING TIP CHORD	FT	10
85	WING ROOT CHORD	FT	10
86	WING MACH		0.5
87	WING TAPER		0.5
88	WING SWEPT	DEG	0
89	WING INC	DEG	0
90	WING TRAIL	FT	0
91	WING AREA	SQ FT	1200
92	WING SPAN	FT	30
93	WING TIP CHORD	FT	10
94	WING ROOT CHORD	FT	10
95	WING MACH		0.5
96	WING TAPER		0.5
97	WING SWEPT	DEG	0
98	WING INC	DEG	0
99	WING TRAIL	FT	0
100	WING AREA	SQ FT	1200

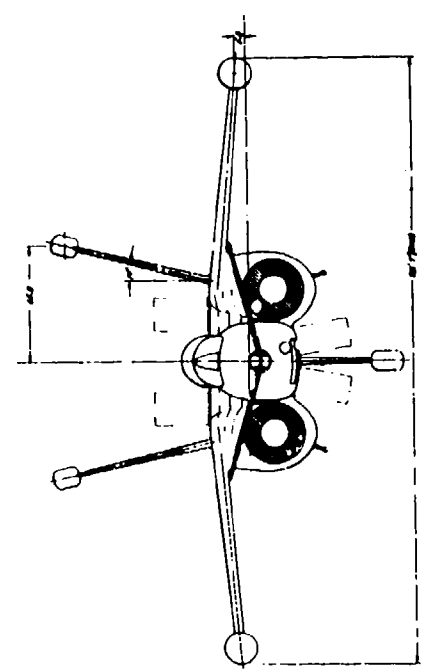

Figure 3.3.5.4.4 General Arrangement, Lockheed CL-295-2 Independent VATOL Airplane Design with GE J79-X207 Engine

of the self-erecting VATOL aircraft. No suitably-sized turbo-jet engines in development appeared to be available at the start of the CL-295-4 studies when engines were being selected.

Subsequently, a modified version of the CL-295-1 was laid out using a single, larger version of the X-84 engine to explore the merits of the turbofan versus the turbojet. This version was designated CL-295-3 (Figure 3.3.4.2). After the study was well under way, General Electric announced an advanced J-79 engine with exceptionally high thrust-weight ratio (T/W) and Lockheed elected to investigate the CL-295-4 independent airplane designed to use two of these engines. The resulting design was designated CL-295-2 (Figure 3.3.5.4.4).

Because the CL-295-3 and CL-295-2 designs were started late in the study program, they were developed in considerably less detail than the CL-295-1 and CL-295-4, Lockheed's primary designs.

Since the engines used in each of the four designs differed in thrust and weight and their state of development, direct comparisons among the aircraft are difficult. Table 3.3.5.4.1 summarizes characteristics of the four designs. Table 3.3.5.4.2 summarizes the performance of the CL-295-1 and CL-294-4 Lockheed's primary designs.

TABLE 3.3.5.4.1

WEIGHT\*, THRUST\* AND DIMENSION SUMMARY LOCKHEED VATOL  
 DAY FIGHTER DESIGNS

Design	<u>Dependent Aircraft</u>		<u>Independent Aircraft</u>	
	CL-295-1	CL295-3	CL295-4	CL-294-2
Engine, (Number)	Wright TJ32C4 (1)	G.E. X-84 39.1" Dia. (1)	G.E. X-84 38.1" Dia. (2)	G.E. J79-X207 (2)
Total Rated Thrust, S.L. Std. Day	24,000	20,100	24,820	36,000
Net Thrust, S.L. Std. Day	22,175	17,750	22,100	31,300
Net Thrust, S.L. 99°F	18,860	14,660	18,240	27,410
Empty Weight	12,905	9,527	12,030	18,110
Combat Weight	18,767	14,940	18,308	25,795
Useful Load, S.L. Std. Day	7,396	6,745	7,787	9,665
Weight, Zero Fuel	14,095	10,717	13,300	19,380
Area Intercept Mission, T.O. Wt.	18,115	14,059	17,533	25,280
Area Intercept Mission Fuel Wt.	4,020	3,342	4,233	5,900
Take Off Thrust/Wt	1.041	1.043	1.040	1.084
General Purpose Mission, T.O. wt.	20,301	16,272	19,817	27,774
General Purpose Fuel Wt.	6,206	5,555	6,517	8,395
Take Off Thrust/Wt.	1.092	1.091	1.115	1.127
Span	22'11"	20'11"	23'4"	28'7"
Length	50'0"	45'4"	42'6"	44'8"
Wing Area, Sq. Ft.	210	175	190	295
Wing Loading @ Combat Wt., lb/sq ft.	89.4	85.4	96.4	87.4

\*All weights and thrusts are in pounds.

**TABLE 3.3.5.4.2  
 PERFORMANCE SUMMARY  
 LOCKHEED CL-295-1 AND CL-295-4 DESIGNS**

		<u>REQUIREMENT</u>	<u>CL-295-1</u>	<u>CL-295-4</u>
Engine			Wright TJ32CA (1960 Turbojet)	Two GE X-84 (Proposed Turbofan)
At 35,000 Feet, at Combat Wt.,	lbs.	----	18,767	18,308
Maximum Speed	Mach. No.	1.6	2.09*	2.2*
Accel., Max. Speed (Mil. Power) to Max. Speed, at 1.2 g	Minutes	3	1.0	1.58
Maximum Speed, Mil. Power	Mach. No.	---	1.22	0.96
Combat Radius, General Purpose Mission				
For $M_{\text{combat}} = M_{\text{max}}$	N. Mi.	200	200	200
For $M_{\text{combat}} = 1.6$	N. Mi.	---	350	350
Combat Altitude	Feet	50,000	60,300	63,000
Ceiling, Military Power	Feet	45,000	46,500	45,600
Normal Acceleration in Steady Turn at 45,000 Feet		1.5 g	1.5 g, M = .87 1.65 g, M = 1.05 2.75 g, M = 2.09	1.5 g, M = .84 1.7 g, M = 1.0 3.5 g, M = 2.5
Rate of Climb, Max., Sea Level	Ft./Min.	---	65,000	63,300
Rate of Climb, Max., 35,000 Feet	Ft./Min.	---	40,000	55,000
Time to Climb to 50,000 Feet at M = 0.9	Min.	---	1.75	1.05
Maximum Speed, Sea Level	Mach No.	---	1.06*	1.20*
Maximum Speed, above 40,000 Feet	Mach No.	---	N.A.*	2.5*

\*Limited by engine operating restrictions

Regarding vertical take-off at higher temperatures and altitudes Lockheed proposed to use rockets to boost take-off thrust. For each of the designs provision was to be made for four 1,000 lb., 30 second thrust rockets to raise the hot day sea level T/W ratio at take-off to over 1.05 for the Air Force specified Area Intercept mission.

Because of the differences in engines direct comparison of aircraft weights and performance capabilities is misleading. Several significant conclusions regarding the designs can be drawn, however

1. All of the VATOL designs easily exceed the requirements stipulated by the Air Force (see Table 3.3.5.4.2). Actually, maximum speeds were constrained by structural and temperature limits of the engines.

2. The dependent airplane is the lightest possible VATOL machine being only 10.5 percent heavier than a F-104 (zero fuel weight). Incorporation of integral, self-erecting undercarriage increases the weight penalty to 52 percent.

3. Even with the engines being developed for use in the early 1960's it was possible to design a Day Fighter of very reasonable size which combines VTOL with speed and altitude performance better than that of the highest performance conventional Day Fighter available (1954), the Lockheed F-104.

4. Engine thrust/weight is an important factor. Replacing the 1960 turbojet with an advanced turbofan of the correct size resulted in the dependent airplane weighing 20 percent less than the F-104. The CL-295-3 with advanced turbofan is 24 percent lighter than the similar design CL-295-1 with 1960 turbojet.

5. Regarding tail sitters without self-erecting undercarriage, Lockheed was convinced, as was Ryan Aeronautical, that such aircraft required more complex ground equipment than the dependent (cable hanging) type and therefore were less desirable as a VATOL design solution for the Day Fighter.

A number of features, characteristics and considerations were common to all the VATOL airplanes in the Lockheed study. All designs were sized to have a T/W near 1.05 or greater with assist (rockets) on a NASA hot day (99°F) at sea level when taking off with full ammunition and sufficient fuel for the Area Intercept mission (200 nm combat radius). The 1.05 T/W was based on previous work by Lockheed. It was considered to be optimum because it resulted in the least weight airplane. At heavier weights and higher altitudes rockets were to be used. The General Purpose mission was based on take off under standard day sea level conditions. This permitted increase in useful load over the hot day operation because of the higher engine thrust available.

Early in the study it was found that engines, turbojet and turbofan, with sufficient thrust for take off had more than enough thrust to meet or exceed the Air Force specified requirements (see Table 3.3.5.4.2). Since differences in specific fuel consumption among turbjet and also

turbofan engines were small compared to differences in thrust/weight, the latter was the key factor in selecting the preferred engine from among those available in the proper size class.

Low Speed Flight Considerations: Lockheed's analysis indicated that minimum fuel would be consumed if a take-off T/W of 1.05 was used followed by a constant altitude transition to a speed 10 percent above stall. This would require a total of 44 seconds (8 seconds to climb to 50 ft. height and 36 seconds for the tilt-over phase), about a 2-1/2 deg./sec. average tilt rate. Landings also would be done at constant altitude. They would be programmed to have a 0.25 g deceleration and require about 3000 ft., in zero wind, from the point where the airplane reached a speed 10 percent above stall. Lockheed stated that all of their VATOL designs were capable of meeting the Air Force requirement of taking off and landing in a 40 Kt. wind from a 200 ft. square area surrounded by 50 ft. high obstacles.

To counter stall-induced buffeting and asymmetric stall effects (uncontrollable roll), to lower stall speed and improve aileron control during transition flight the designs had wings equipped with nose and aft flaps. Blowing boundary layer control was applied to the trailing edge of the nose flap and leading edge of the aft flap using air bled from the engine compressor. The wing was divided into segments for blowing purposes. Selective blowing of segment pairs was used to reduce buffeting and maintain aileron effectiveness, with cessation of blowing starting at the wing root and progressing outboard as speed was reduced. This segmented blowing system was used to minimize engine compressor bleed at lower speeds when maximum thrust was needed from the engine to support the airplane. Below 50 ft. per second, blowing was not used because stall buffeting was low at these low dynamic pressures. In normal operation, the blowing system was to be controlled automatically by the autopilot but manual control of blowing was available to the pilot for emergency use.

Lockheed suggested that, after the independent airplane (self-erecting tail-sitter) had reached vertical attitude in a landing operation, it be flown sidewise (lateral translation) to the landing spot to minimize drag and provide the pilot with maximum visibility of the ground and landing area. A 40 Kt side wind required only 5 degrees of yaw. It is interesting to note that this maneuver was used by the pilots of the X-13 hanging type VATOL airplane because they then had full vision of the ground and landing rig during the approach. Once near the rig's horizontal cable a 90 degree roll to belly-first translation put the airplane in cable-engaging position.

The aircraft were designed to be stable about all three axes in conventional mode flight but they were inherently unstable in pitch and yaw during vertical and low speed flight. This instability was not expected to be a sig-

nificant piloting problem because of the long natural period of any oscillation and the powerful pitch and yaw control available. This was Lockheed's experience with the XFV-1 tail sitter airplane in vertical mode flight. NACA's tests of VATOL jet-powered models showed that they could be flown with little difficulty in vertical mode flight.

Although low speed and hovering maneuvers could be performed by the pilot without stability augmentation system assistance, a programmed autopilot was incorporated to reduce pilot workload, improve flight safety and reduce fuel consumed during take-off, landing and transition flight. The functions of the autopilot were: coordination of throttle and pitch control for optimal constant altitude take-off and landing transitions; stability augmentation, particularly in near vertical attitudes; hovering translation at selected speeds; and programmed activation of low speed controls and operation of flaps, engine cowl doors and the boundary layer control system. The rate gyros and amplifiers of the autopilot were to be used for roll and yaw damping in high speed flight. The complete autopilot was available for pilot relief in normal cruising flight. Analyses of XFV-1 and F-104 flight and simulator experience showed that emergency operation without autopilot was entirely feasible.

Non-Aerodynamic Control: Below stall speed through transition and vertical flight, moments on the VTOL aircraft can be produced by applying jet reaction forces to the extremities of the vehicle. This can be done by having separate jets at the reaction points or by deflecting the primary jet exhaust. Lockheed's basis for selection of the best system was to use the one which resulted in least weight penalty and thrust loss and that, preferably, had no effect on conventional mode flight performance and control. Although compressor-bled air jets at the wing tips were selected for roll control, this method was rejected for pitch and yaw because it resulted in prohibitively high engine thrust losses.

Four methods of deflecting the jet exhaust for pitch and yaw control were investigated: swivelling nozzles, fluidic deflection of exhaust (injection of air at nozzle exit at right angles to primary flow), insertion of a plate into exhaust stream at nozzle exit, and retractible vanes in the exhaust. Based on minimum weight penalty and thrust loss the last method was found superior to the others. Lockheed recognized the severity of the problem of vanes in the 3500°R afterburner exhaust, there being no material (at the time) able to operate in this temperature without cooling. Internally cooled vanes using Inconel X material (good for 2360°R) were designed to be folded out of the exhaust flow in conventional mode flight. Cooling air was supplied by bleeding the engine compressor. Figure 3.3.5.4.5 illustrates the vane system. Airplane pitch control required the highest vane forces, as much as 1870 lbs. during the critical flight condition of the CL-295-1 design. Two vanes were used for pitch control but only one for yaw because yaw required about one-half the force needed for pitch.

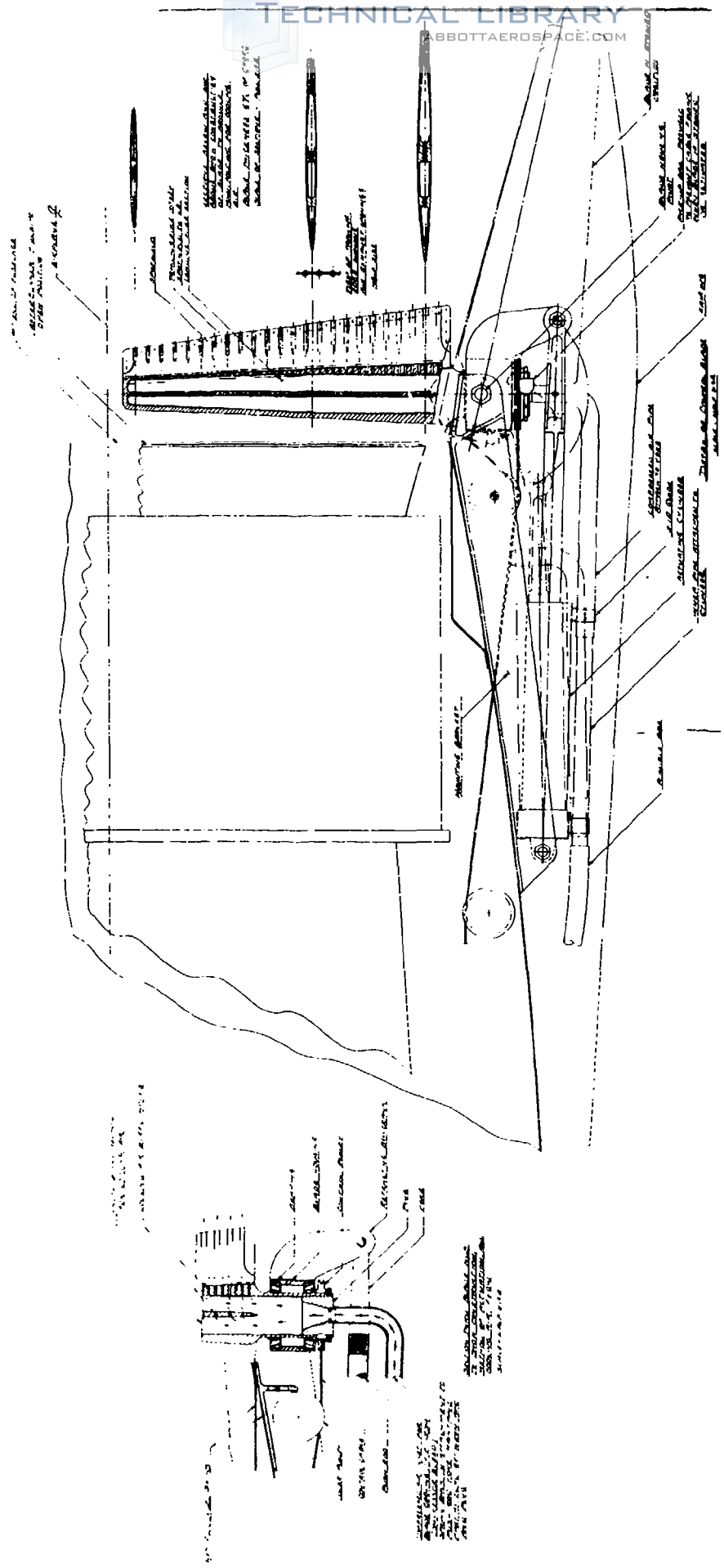

Figure 3.3.5.4.5 Lockheed VAPOL Airplane Design Vane System for Low Speed and Vertical Flight Control (Courtesy Lockheed Corporation)

The vanes used 6 percent thick, symmetrical airfoils suitable for use the  $M=1.195$  exhaust flow.

In supplying air to the wing tip roll control nozzles, continuous engine bleed was used. The nozzle flows were normal to the wing plane, the purpose being to keep roll control thrust demands from affecting the vertical thrust acting on the airplane in vertical mode flight. In conventional mode flight engine bleed was shut off.

#### CL-295-1 (and CL-295-3) Dependent

Airplane Characteristics: The CL-295-1 was the lightest design possible based on an engine then in development. This was accomplished by using the dependent airplane approach, permitting the minimization of undercarriage provisions in the aircraft. Only a hook and belly protective strip were required.

Since speed and altitude capabilities of the VATOL fighter were essentially the same as those of the F-104 Air Superiority Fighter, Lockheed elected to use the F-104 basic configuration and design parameters for the dependent VATOL designs, except where changes resulted in improved suitability for VTOL. This allowed maximum advantage to be taken of the extensive work already done in developing the F-104 and reduced risk in designing a successful VATOL fighter. The resulting dependent VATOL CL-295-1 airplane (Figure 3.3.5.4.1) was relatively conventional in design using a thin, straight wing of low aspect ratio (2.5), and resembled the F-104 in overall arrangement. A Wright TJ32C4 engine, scheduled for operational availability before 1960, supplied sufficient thrust to meet or exceed all performance requirements and to permit take-off, unassisted, with fuel for the specified General Purpose mission on a sea-level standard day. Rocket assist would be used for higher take-off temperatures and altitudes. Major unconventional features of this VATOL airplane were: the incorporation of a biplane horizontal tail to reduce pitching moments through the stall to controllable values; the use of segmented boundary layer control to reduce rolling moments through stall and the provision of vanes in the jet exhaust and use of variable area bleed air nozzles at the wing tips for low speed control. The wing of CL-295-1 had increased thickness over that of the F-104, 5 percent instead of 3.4 percent.

Design CL-295-3 (Figure 3.3.5.4.2) was a modification of CL-295-1, made to use the G.E. X-84 proposed turbofan instead of the Wright TJ32C4 turbojet. The higher thrust/weight of the turbofan engine resulted in an even lighter Day Fighter than the CL-295-1, 10,717 lbs. zero fuel weight versus 14,095 lbs. It should be noted that the CL-295-1's empty weight was only 10.5 percent greater than that of the F-104 and that the CL-295-1's climb and high speed actually exceeded that of the F-104. The CL-295-3's empty weight was 20 percent less than that of the F-104. CL-295-3 outperformed the CL-295-1.

Like the F-104 the CL-295-1 (and CL-295-3) design had a shoulder-mounted wing and an all-moving "T" tail. The lower all-moving horizontal tail of the biplane arrangement was a 1/3 scale version of the upper horizontal surface.

Conventional aluminum alloy construction was used in the airframe. About one-half of the fuselage length was occupied by the engine and part of the remainder by the inlet ducts. The aft portion of the fuselage supported the tail surfaces and housings for the retractable pitch and yaw vanes and was removable for access to the afterburners and to permit engine removal. All fuel for the design mission was stored internally in the fuselage in three tanks.

Fuselage: Electronic equipment was housed in the nose. The cockpit (Figure 3.3.5.4.6) was pressurized and provided for downward ejection of the pilot, as in the F-104. The seat could tilt forward 22-1/2 degrees to improve pilot comfort and vision during vertical attitude flight. The canopy opened by sliding aft to permit increased pilot head movement for better downward and sideward vision. A retractible belly hook was located just below the pilot's feet to make it easier for the pilot to maneuver the airplane to place the hook on the landing cable. A replaceable keel was attached to the fuselage bottom to protect against cable scuffing.

Located in the space between cockpit and engine were: the electrical system, air conditioning, autopilot hydraulic units, engine inlet ducts, main fuel tank and armament installation -- 20 mm machine gun with 800 rounds of ammunition.

The fuselage was laid out to combine low aerodynamic drag ("area-ruled"), good vision from the cockpit in vertical flight, and ready access to auxiliary systems. The engine air inlets were based on a two-shock system design. The cone angle and duct lip geometry provided shock impingement at the lip at Mach 1.8 to give optimum external shock recovery. The area of the sharp lip inlet was chosen for proper airflow at Mach 0.9, 35,000 ft while, for higher speeds, the excess internal air was bypassed around the engine to the exit nozzle for best recovery. Since the high speed inlet design had poor pressure recovery during vertical and low speed flight because of insufficient inlet area and the sharp lip, auxiliary inlet area was provided. This was obtained by moving the inlet cowls forward to expose an auxiliary inlet with a round lip and additional inlet area (Figure 3.3.5.4.7).

Powerplant: The 24,000 lb. thrust with afterburning (S.L. Std. day) Wright TJ32C4 turbojet engine was selected because it had the highest T/W of engines in its thrust class. A mechanical convergent-divergent nozzle for afterburning operation was provided. This nozzle was canted 2-1/2" degrees upward to reduce pitch control vane deflection

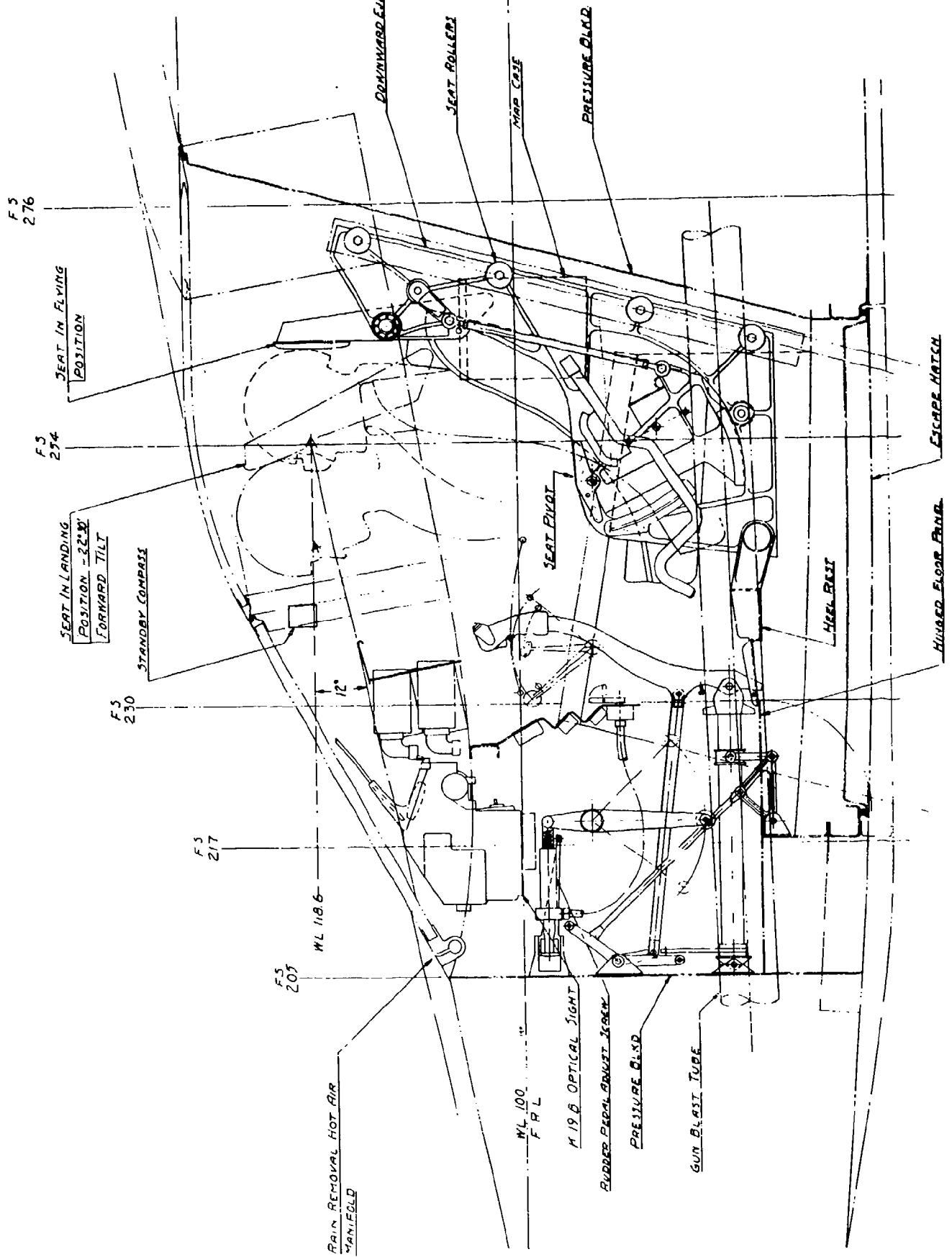

Figure 3.3.5.4.6 Lockheed CL-295-1 VATOL Airplane Design Cockpit Arrangement  
(Courtesy Lockheed Corporation)

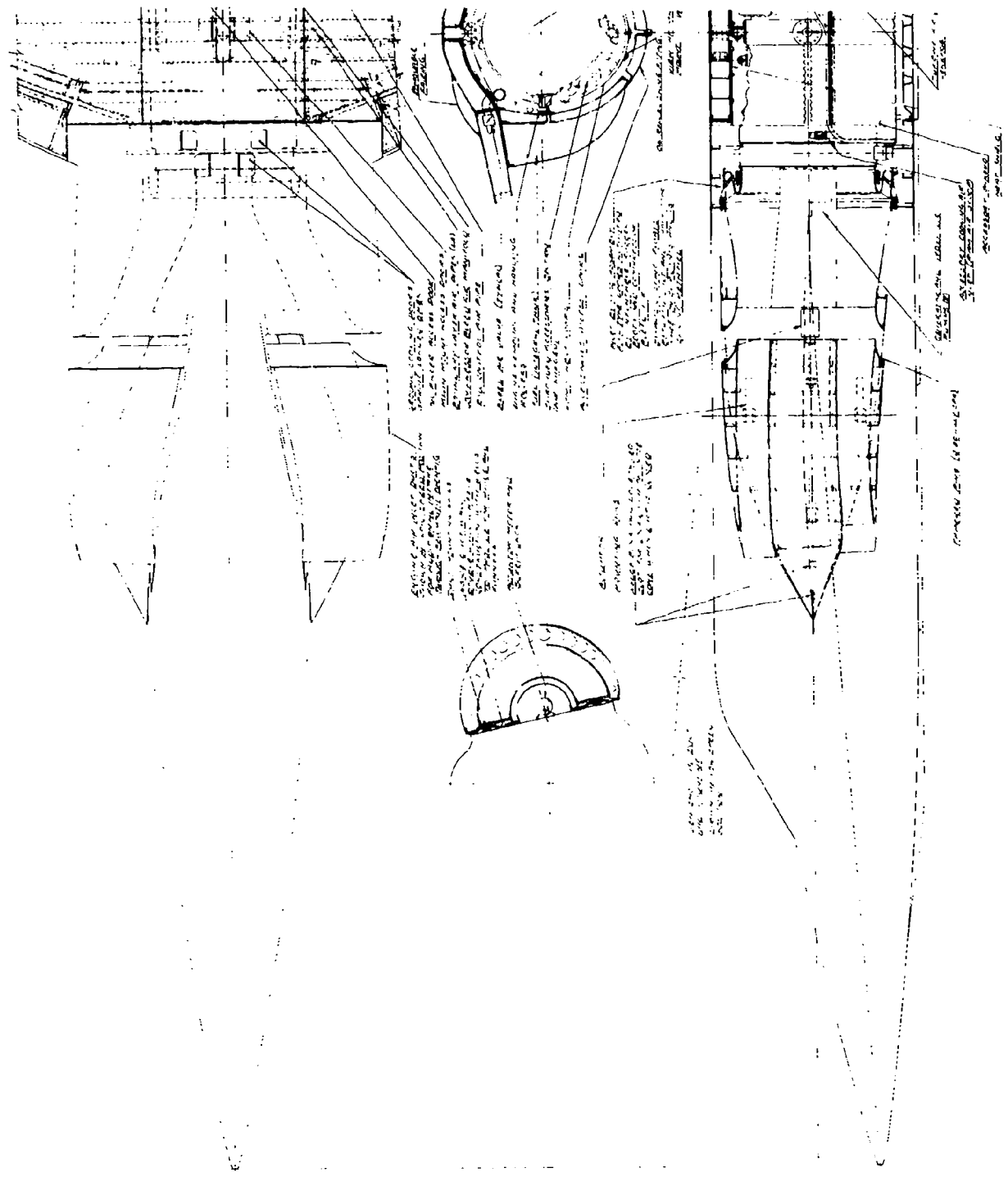

Figure 3.3.5.4.7 Lockheed CL-295-1 VATOL Airplane Design Forward  
Fuselage Showing Auxiliary Air Inlet System  
(Courtesy Lockheed Corporation)

(trailing edge up) needed to handle pitching moments during transition between stalled and low speed flight.

Flight Control System: The aerodynamic flight control system was similar to that of the F-104 and had fully power-operated irreversible mechanisms with artificial feel. Two completely independent systems were installed at each control surface to provide flight safety should either system fail. The autopilot was connected through servos to the aileron and rudder control system to provide yaw and roll damping.

Lockheed's rationale for using vanes at the engine exhaust nozzle for vertical and low speed flight pitch and yaw control was touched upon earlier. The vanes were connected in parallel with the aerodynamic surface controls at all times but were activated only in low speed and vertical flight. Because the hinge moments of the vanes were low no power assist was provided for their operation. Figure 3.3.5.4.5 shows details of the pitch and yaw vane control system. The vanes or "blades", to be built-up using Inconel X sheet material, allowed cooling air, bled from the engine compressor, to flow in at the blade root and exit from the trailing edge. Vane incidence angle was controlled via a cable and pulley system equipped with high temperature bearings at the vane trunnion. In conventional-mode flight, to reduce propulsive loss and extend their life the vanes were swung out of the exhaust into fairings attached to the fuselage, the movement being provided by hydraulic actuators. Simultaneously, the air lines to the vanes were disconnected and compressor bleed stopped.

The roll control approach, using reaction jets at the wing tips, also was discussed earlier. Dual variable area nozzles, exhausting up and down, were used to provide reaction control thrust. In neutral, the up and down nozzles produced equal thrust. Through use of a rocker shaft mechanism and flexible nozzle walls, differential variation of throat area between upper and lower nozzles was produced causing differential thrusts but essentially keeping total mass flow constant. The variable area nozzles were of the convergent-divergent type and designed to produce sonic flow in the nozzle throat even at maximum opening.

CL-295-3 Design: To show the effects on airplane size and performance of using advanced engine types, Lockheed designed CL-295-3, (Figure 3.3.5.4.2), similar in configuration to the CL-295-1 design (Figure 3.3.5.4.1), around a modified General Electric X-84 "ducted fan" (turbofan) engine. A 39.1 inch diameter (compressor case) size was selected to give a take-off hot-day T/W equal to that of the CL-295-1 design in the Area Intercept mission. The resulting airplane had essentially the same performance as the CL-295-1 except that the projected higher engine operating limits permitted a maximum speed of Mach 2.2 at 35,000 ft. and Mach 2.5 at 40,000 ft. However, the more advanced engine, sized

exactly for the mission requirement, resulted in an empty weight of 9527 lbs., 26 percent lower than that of the CL-295-1. Take-off gross weight, 16,272 lbs., was 20 percent less than that of the CL-295-1. Table 3.3.5.4.1 provides comparative data for these designs, as well as the CL-295-4 and CL-295-2 independent aircraft designs.

The CL-295-3 design was derived directly from the CL-295-1. Aside from its smaller size the most prominent difference is that the CL-295-3's fuselage fineness ratio and length are less than that of the CL-295-1 because the turbofan engine had a larger diameter and shorter length than the CL-295-1's turbojet engine.

Ground Handling Equipment: The basic requirement for the dependent aircraft's ground handling system was to have a horizontal cable high enough to give sufficient and safe ground clearance to the airplane during the hook-to-cable engagement action. Lockheed recognized that the ground apparatus could take various forms including one similar to that used by Ryan Aeronautical (Figure 3.3.2.14). The system selected by Lockheed for an in-depth analysis is that shown in Figures 3.3.5.4.8 through 3.3.5.4.11. This apparatus was designed to be broken down for air transportation and air drop (parachute) and to be set up in a few hours. The apparatus had a set of cables strung between two masts, held upright by guy wires (Figure 3.3.5.4.8). Powered hoisting provisions were incorporated for lowering the airplane to the ground and raising it to take-off position. Two landing cables were provided for safety (Figure 3.3.5.4.9) and to permit the inactive cable to help lower the airplane into position on the cart (Figure 3.3.5.4.10). The two mast system could receive and launch one airplane in two directions. By adding a third mast (Figure 3.3.5.4.11) three airplanes could be handled simultaneously in light winds. In strong winds the system would provide three landing approach directions for one aircraft. Included in the system, shown in Figure 3.3.5.4.8, was an exhaust pan with ducts to carry the exhaust gases away from the landing area. The airplane could be hauled from and to the mast apparatus and from place to place after it had been positioned on the ground handling cart.

CL-295-4 (and CL-295-2) Independent Airplane Characteristics: After making design layouts to study various self-erecting VATOL aircraft configurations Lockheed concluded that the best approach was the canard configuration as shown in Figure 3.3.5.4.3. The canard layout was selected in preference to other arrangements primarily because it had a low center of gravity in the vertical attitude, and because the wing tips were sufficiently close to the ground to serve as undercarriage attachment points. The canard configuration was determined by Lockheed to offer the lightest and smallest solution to the difficult problem of designing a satisfactory VATOL independent airplane, this being defined as one which incorporated integral undercarriage to eliminate the need for ground

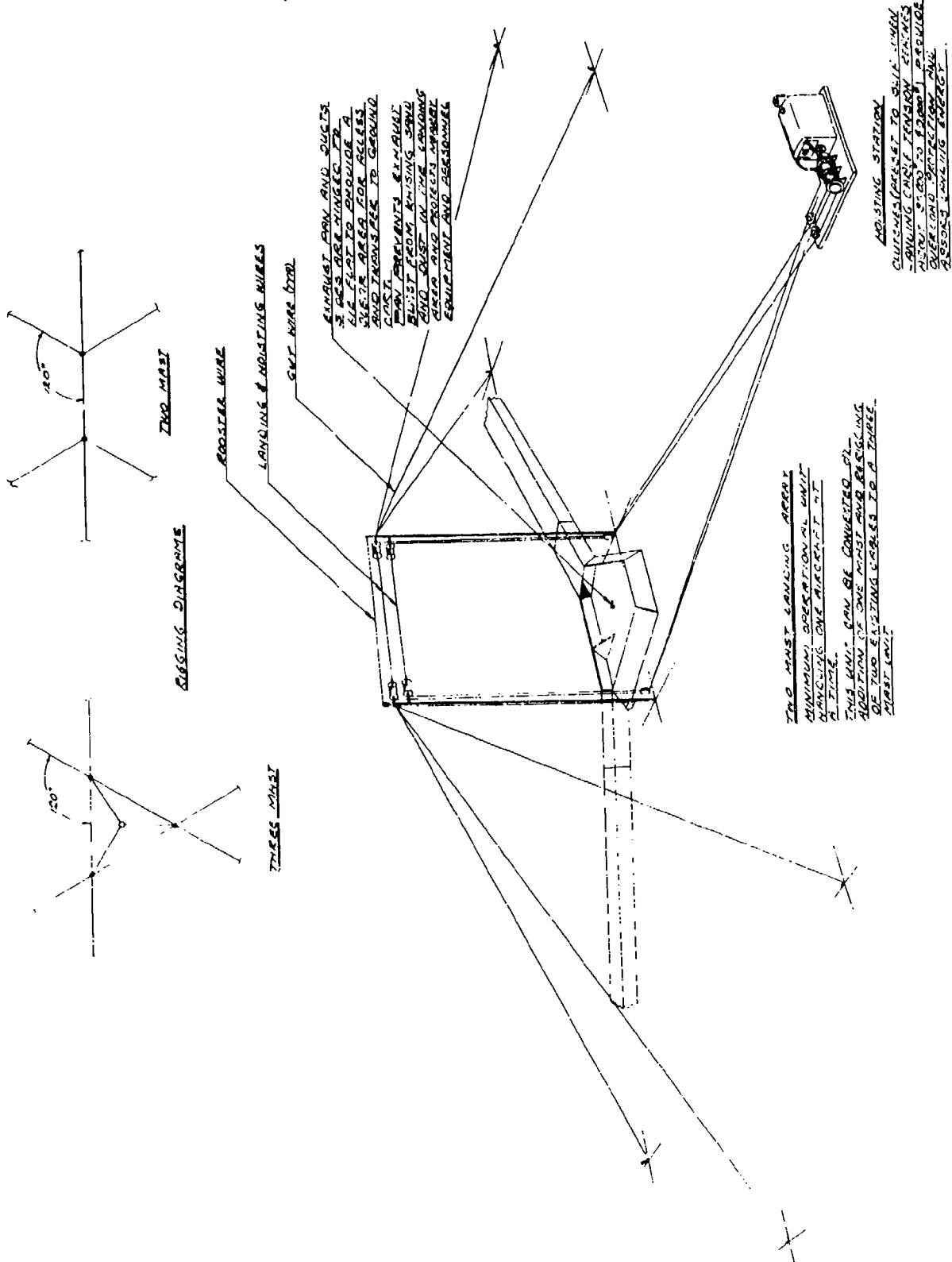

Figure 3.3.5.4.8 Two Mast System for use with Lockheed Dependent Airplanes (Courtesy Lockheed Corporation)

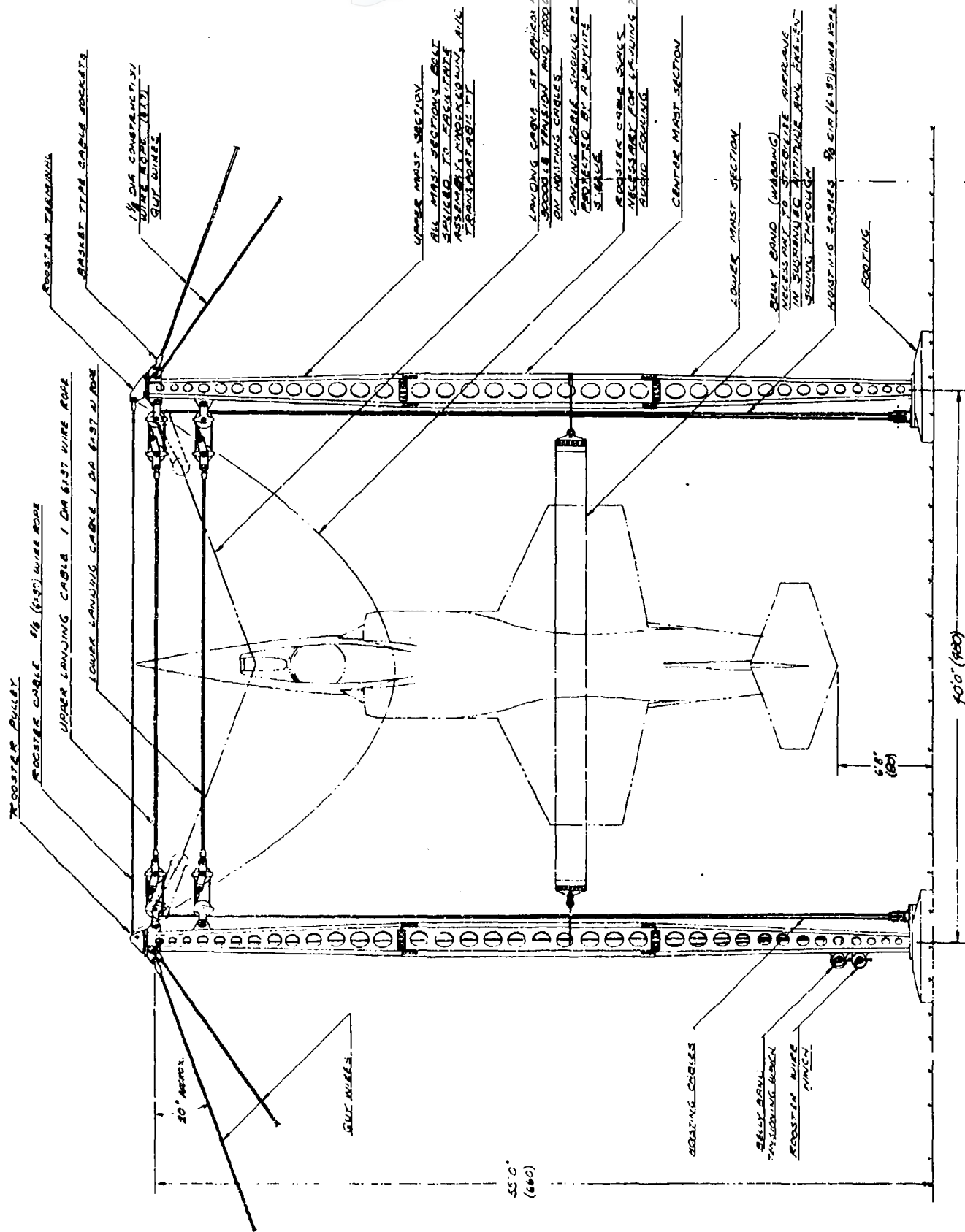

Figure 3.3.5.4.9 Two Mast Ground Handling Apparatus - Face View, Lockheed Dependent Airplane (Courtesy Lockheed Corporation)

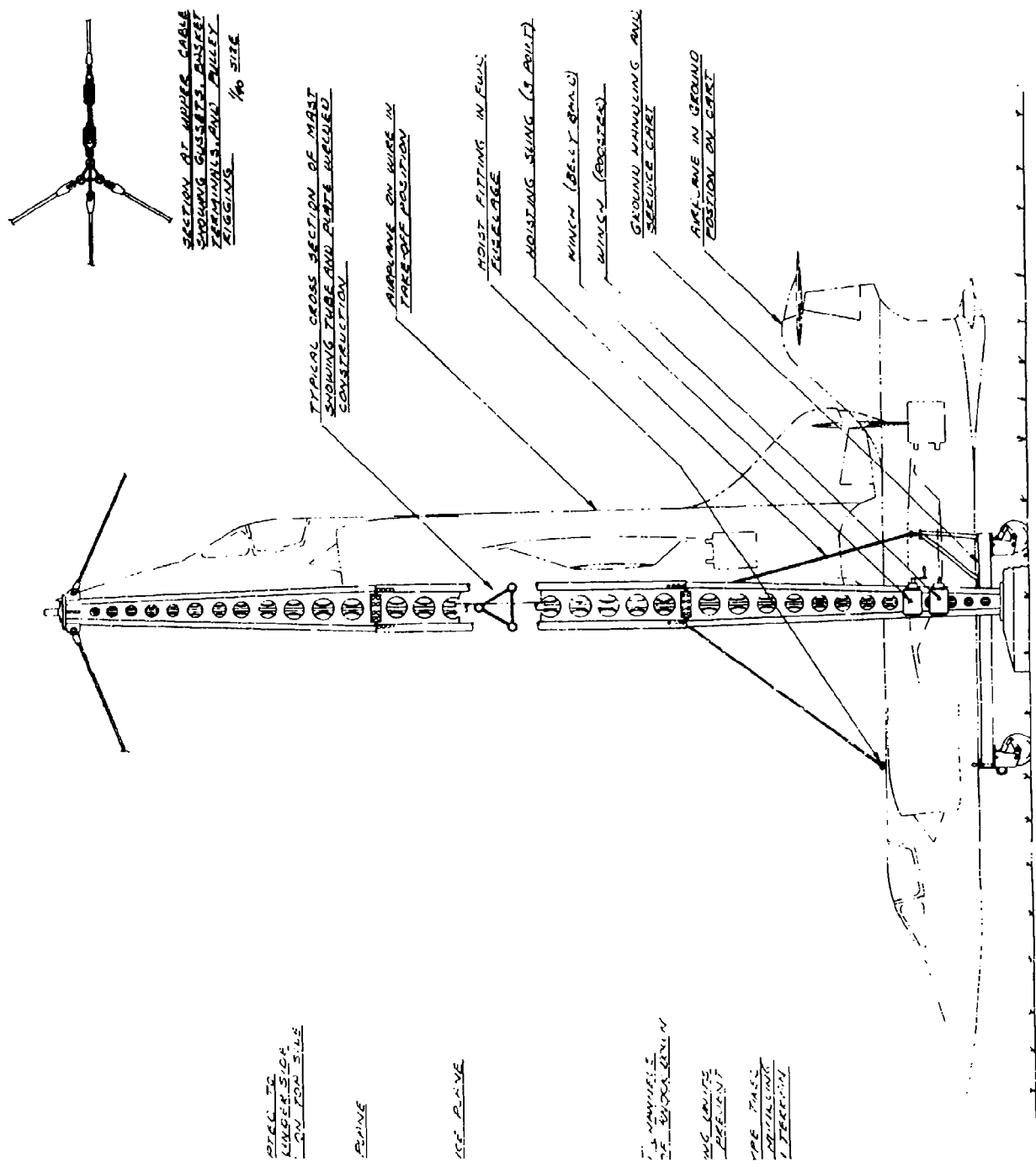
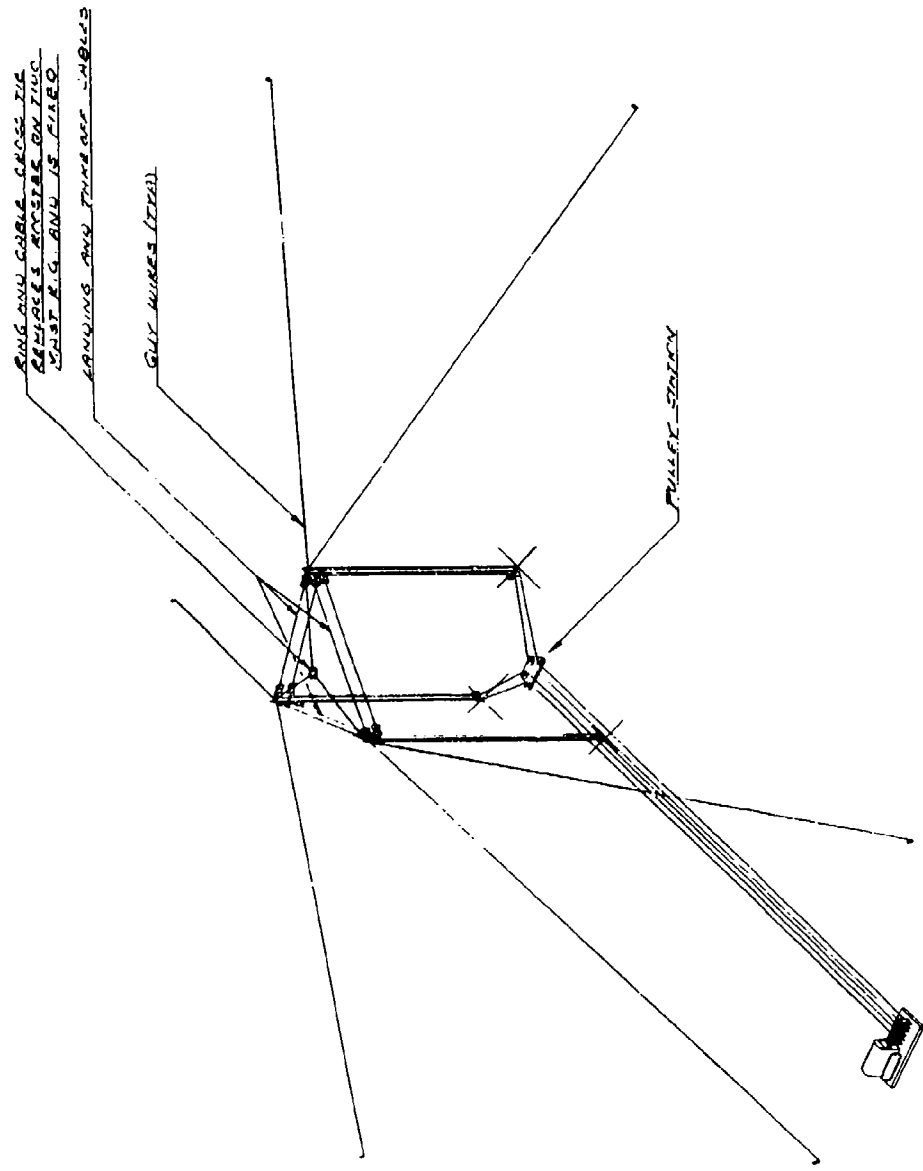

Figure 3.3.5.4.10 Two Mast Ground Handling Apparatus - Side View,  
 Lockheed Dependent Airplane (Courtesy Lockheed  
 Corporation)



THREE MAST LANDING ARROY  
 CAN HANDLE THREE AIRPLANES SIMULTANEOUSLY  
 IN LIGHT WINDS  
 PROVIDES FOR BETTER LINE-UP WITH  
 STRONG WINDS WITHOUT REARRANGING  
 SINCE THREE LANDING DIRECTIONS ARE  
 AVAILABLE  
 REDUCTION OF ROOSTER CABLE SPREADS  
 GROUND MARKING ON RUNWAYS TURN  
 AROUND TIME  
 CABLE CAN BE EASILY SWAPED SIMILAR TO  
 THAT SHOWN FOR THE ARROY ARROY

LIFTING STRAP

Figure 3.3.5.4.11 Three Mast System for use with Lockheed Dependent  
 Airplanes (Courtesy Lockheed Corporation)

rigs. Based on Lockheed's XFY-1 experience, tail sitters without built-in self-erection capability did require ground support apparatus and were, in reality, dependent airplanes.

When Lockheed started the independent VATOL design study the J-67 and J-75 were the only pre-1960 engines for which data were available. Since use of either of these would result in overly large airplanes for the prescribed mission, it was decided to use the newly conceived GE X-84, the most favorable, advanced engine with the highest projected thrust/weight, 6.53. By using the "rubberized" data available, flexibility in sizing of the engine was possible to optimize the airplane design.

After the CL-295-4 design was well under way, General Electric announced the advanced X207 version of the J79 turbojet engine with a pre-1960 date for 150-hour acceptance testing. This engine had an exceptionally high T/W and investigation showed that a configuration similar to CL-295-4 could be designed using two J79 engines. The resulting airplane design, designated CL-295-2, was started too late in the study period to be analyzed and laid out in complete detail. Based on their study results, however, Lockheed believed that the CL-295-2 design merited serious consideration for further study since it had performance comparable to that of the CL-295-4 but was considerably more flexible in that it could take off with military loads greater than those specified by the Air Force.

The cost of incorporating integral undercarriage with self-erecting capability was found to be a 24 percent increase in zero fuel weight of the CL-295-4 over that of the dependent CL-295-3 airplane both using the same generalized study GE X-84 engine.

The low center of gravity is a key requirement for a self-erecting VATOL airplane to minimize the moment needed from the erecting mechanism and to reduce the danger of toppling during the erection cycle. Toppling influences the location of the support points and the layout of the aircraft. A minimum turnover angle of 20 degrees at any point in the erection operation was chosen by Lockheed as a design requirement. Since the powerplant was the largest single item contributing to the empty weight, a low center of gravity required that the engine exhaust nozzle be as close to the ground as possible and that the engine be of short length. After studying several airplane configurations using various erecting gear arrangements a twin-engine design with the erecting gear located in the plane of symmetry was found to be the best approach. Canard or tailless (delta wing) configurations could meet the design requirements but the latter was found to be structurally heavier and had higher trim drag in high speed flight; the canard configuration was preferred.

However, the canard configuration did have a drawback. Use of a fixed canard surface required the airplane center of gravity to be forward, that is higher above the ground than desired for longitudinal stability reasons. A "free-floating" canard surface was essential to permit the aft center of gravity needed by the self-erecting design. But the classical method, use of trailing edge flaps to control the free-floating surface was not acceptable particularly in supersonic flight. Lockheed's solution was to have the elevator "float" at a zero degree local angle of attack through use of a closed-loop servomechanism. Biasing of the floating angle by the pilot's input provided pitch control of the airplane. With this system the lift of the canard surface could be independent of airplane angle of attack and have no effect on airplane stability. Further, if desired, the canard surface could be made to provide any degree of longitudinal stability required.

CL-295-4 Design: Figure 3.3.5.4.3 the general arrangement drawing of this canard-configured airplane shows it to have an aft-mounted tapered wing swept 35 degrees to reduce the length of the wing-tip-mounted undercarriage elements and to move the wing root forward to a more favorable position on the engine nacelles for wing attachment. The twin GE X-84 engines were mounted at the lower wing surface with their nacelles adjacent to and blending into the aft fuselage. Most of the fuel was in large integral fuselage tanks between the nacelles. Additional fuel plus the roll control jets and two of the undercarriage elements were contained in the wing tip pods. The other two undercarriage units were in fairings at the tips of the dorsal and ventral fins. After landing the ventral fin folded forward to lower the airplane to a near-horizontal attitude.

The all-moving canard surface or wing, with about 1/7 the area of the main wing, was mounted at the fuselage nose. The canard wing had dihedral and was positioned high with respect to the engine inlets to reduce possible intake losses due to the canard wing's wake. The cockpit was well-forward on the fuselage.

Despite the great differences in configuration between the CL-295-1 and CL-295-4 designs many features were similar. The airframe was constructed using aluminum alloy; the wing had the same 6 percent thick symmetrical airfoil and used leading edge and trailing edge flaps with blowing for improved aerodynamics in transition and stalled flight. Both aircraft used similar cockpit arrangements, seat-tilting and downward seat ejection. Low speed and vertical flight pitch and yaw control was through use of vanes in the engine exhaust, there being two sets in the CL-295-4 design because there were two engines. Reaction jets at the wing tips provided roll control.

Aside from the "tail-first" arrangement of the CL-295-4 airplane, other differences are found in the fuselage - engine integration; the use of an undercarriage in

the CL-295-4 design; the shorter moment arm from the airplane center of gravity to the pitch and yaw control vanes (CL-295-4 had about 3/4 of the CL-295-1 moment arm length). The CL-295-4's vertical tail had a substantial ventral surface.

Canard Wing: The canard surface's angle was positioned by a closed-loop servo mechanism which normally maintained a local angle of attack of zero. Inputs from the pilot's stick or autopilot introduced bias into the servo loop causing the surface to operate at the desired angle of attack to the local flow, proportional to the bias imposed. Thus, lift of the canard surface was independent of the airplane angle of attack and had no effect on longitudinal airplane stability but provided trimming moments proportional to control movement. In order for the servo system to provide the desired "free floating" behavior of the canard wing, a device sensitive to angle of attack, canard surface hinge moment or other quantities was required. The specific means was not established, this being considered to be beyond the scope of the contracted study effort.

Low Speed Control Vanes: Figure 3.3.5.4.12 shows the left side pitch control vane system. The vane construction was similar to that of the CL-295-1 airplane (Figure 3.3.5.4.5) but in the CL-295-4 airplane only one horizontal vane was used (per engine) and it spanned the entire exhaust nozzle. Pitch vane control was in the aft fuselage along with the mechanism which retracted the blade into the aft fuselage. The retracting system rotated the blade aft on a curved track linkage and then pulled it forward into the aft fuselage. Cooling air bled from the by-pass compressor entered the vanes at their hubs through fixed manifolds surrounding the blade roots. The yaw vanes were similar in design to those used on the CL-295-1 airplane and extended partially across the exhaust nozzle. The yaw control vanes retracted into the kneeling fins attached to the lower portion of the engine nacelles.

Engines and Nacelles: The GE X-84 turbofan engines were sized to have a 30.1 inch compressor diameter, each engine was to have a thrust of 12,410 lb (S.L. Std. day). The expected T/W was 6.53 but, after the CL-295-4 design was essentially completed, General Electric issued firm data on the X-84 proposed engine which, for the CL-295-4 design would have resulted in an engine T/W of 4.55. Despite this, Lockheed believed that the CL-295-4 design was still indicative of VTO airplane sizes and performance potentials with advanced engines.

As can be seen from Figure 3.3.5.4.3 the engines and nacelles are tilted nose down 5 degrees at the intake and 2-1/2 degrees at the exhaust. The purpose being to lower the intake with respect to the canard wing and to balance the up and down deflections of the pitch control vanes. The inlet design was similar in principle and basic parameters to that of the CL-295-1 design. A two shock system with conical diffuser and sharp lip inlet duct was used. For vertical and

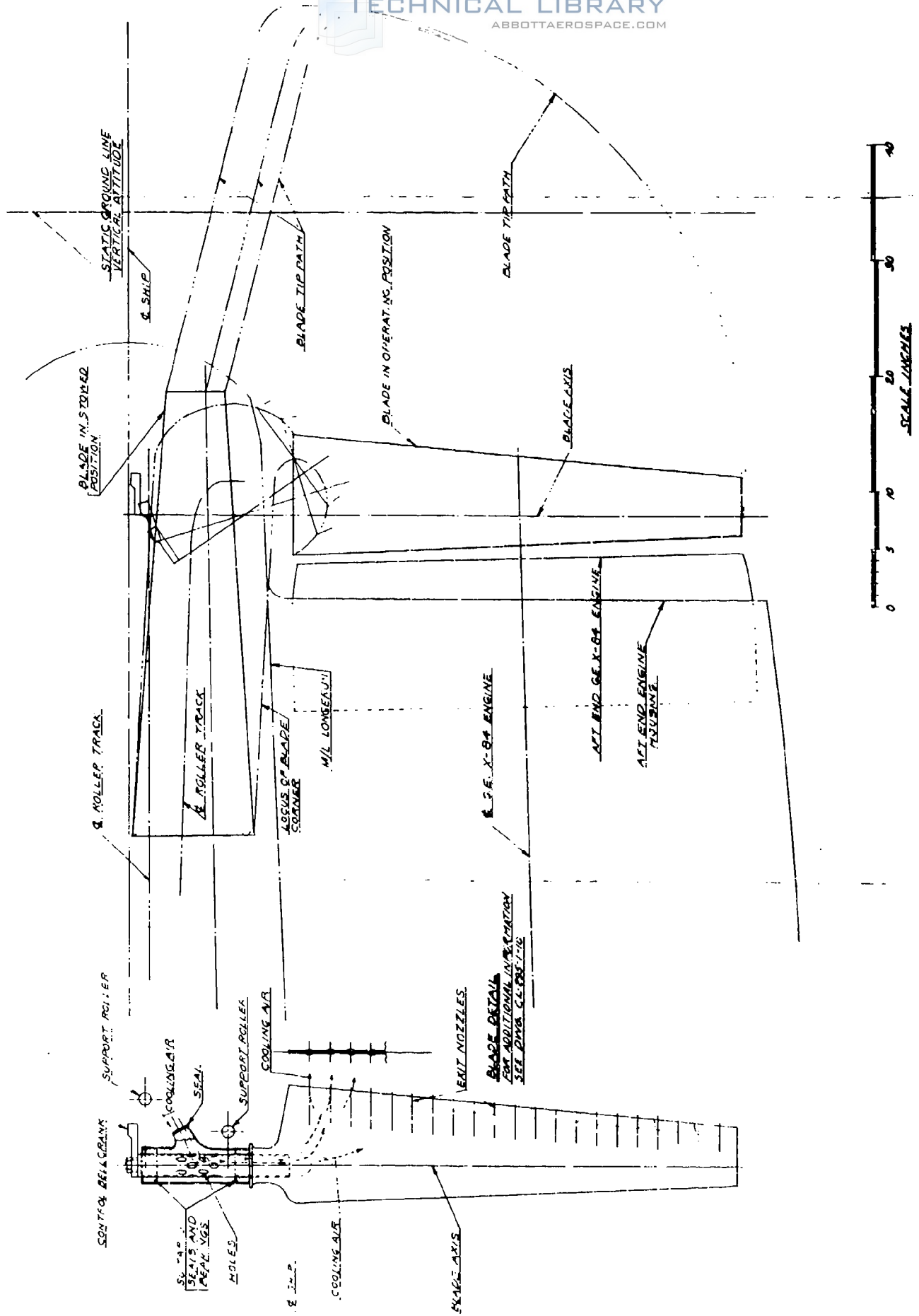

Figure 3.3.5.4.12 Pitch Control Vane System for Low Speed and Vertical Flight, Lockheed CL-295-1 (Courtesy Lockheed Corporation)

low speed flight the outer cowls slid forward on tracks to increase inlet area and provide a rounded inlet lip.

Undercarriage and Self-Erection System:

Figure 3.3.5.4.13 shows the undercarriage system and method of tilting the airplane between vertical and near-horizontal positions. The airplane rested on four freely-swivelling wheels attached to conventional air-oil shock struts. These were attached to the tips of the wings and dorsal and ventral vertical fins. Special tires would be used to resist the high temperature gases during landing and take-off. In flight, the shock struts were compressed to reduce the size of the fairing pods.

Operation of the erecting system is depicted in Figures 3.3.5.4.13 and Figure 3.3.5.4.14 shows details of the folding ventral fin used to tilt the airplane. When in near-horizontal attitude the airplane rested on three support points: the pads of the kneeling fins projecting downward from the bottom of the engine nacelles (see Figure 3.3.5.4.3) and the wheel mounted on the ventral fin which had been folded forward about a laterally-oriented pivot in the fuselage. Rotation of the fin back to its normal flight position applied the erecting moment to the airplane. When position III in the diagram (Figure 3.3.5.4.13) was reached the wing tip wheels contacted the ground and the kneeling fins left the ground. As the airplane reached vertical attitude, the fourth support point, the wheel aft of the dorsal fin contacted the ground. Throughout the sequence the stability against toppling over was at least equal to that in the take-off position. Total erection time was to be about two minutes. Rotation of the ventral fin was through the action of an integral, gear driven block and tackle system driven by a 5 horsepower hydraulic motor receiving power from a ground service cart. The airplane could be lowered using gravity, with the descent speed being controlled by restricting the flow of hydraulic fluid in the system.

CL-295-2 Self Erecting Design: This design (Figure 3.3.5.4.4) was initiated as a consequence of General Electric's announcement of the forthcoming availability of the J79-X207, this jet engine having a very favorable T/W. Lockheed used the CL-295-4 as the basis for the CL-295-2 making changes required to accommodate the larger, more powerful engines having a combined engine thrust of 36,000 lb. The CL-295-2 was by far the largest of the VATOL designs. Its zero fuel weight, 19,380 lb., was 37 percent greater than that of the CL-295-1 dependent airplane, also based on a current state-of-the-art engine. However, the CL-295-2 design by virtue of its high thrust, could carry an overload and still meet the 1.05 T/W at take-off for the Area Intercept mission on a hot day. The excess lifting capability could be used either for larger military loads or longer range. This airplane was capable of accomplishing more demanding missions than specified by the Air Force.



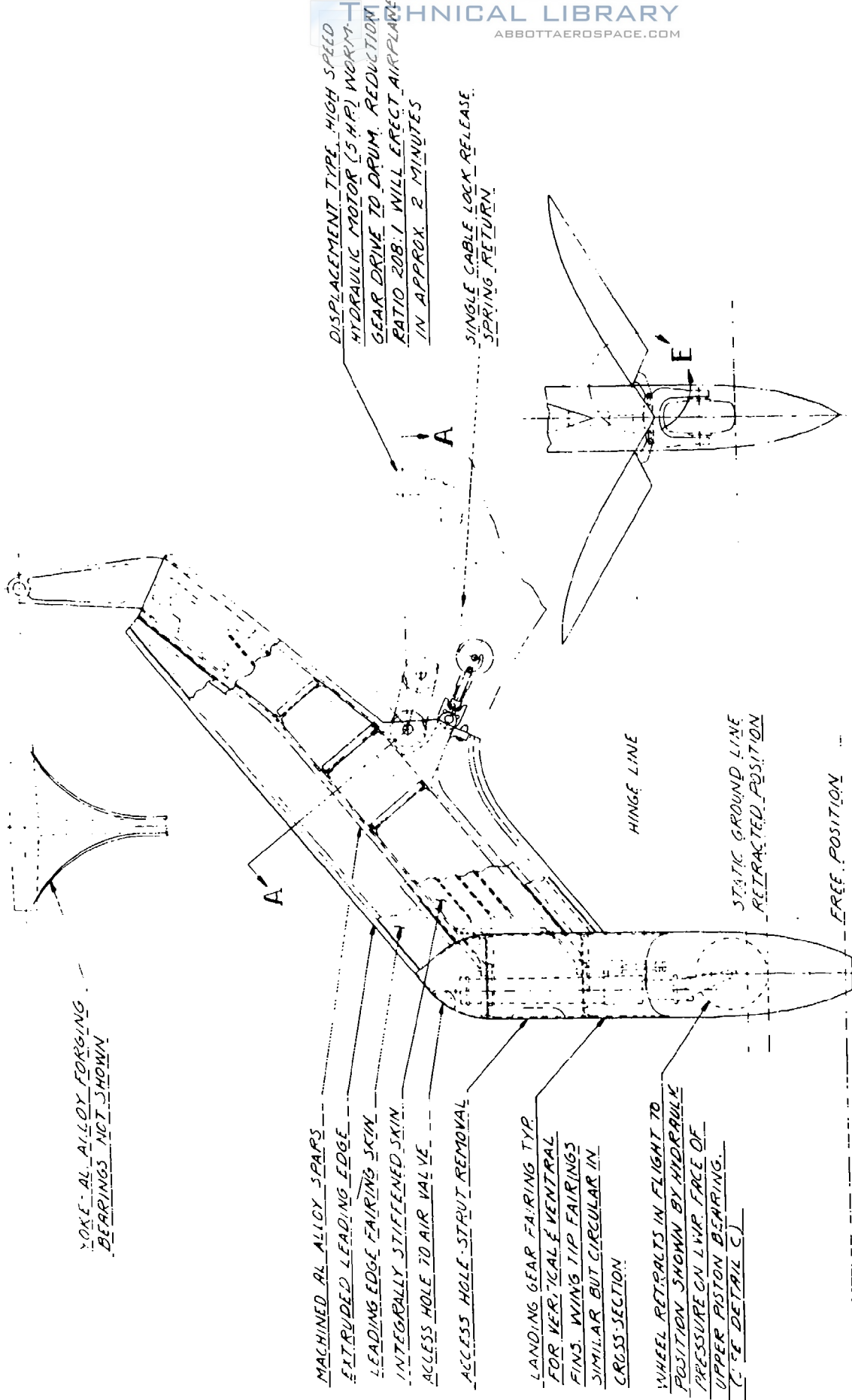

YOKER AL ALLOY FORGING BEARINGS NOT SHOWN

MACHINED AL ALLOY SPARS  
EXTRUDED LEADING EDGE  
LEADING EDGE FAIRING SKIN  
INTEGRALLY STIFFENED SKIN  
ACCESS HOLE TO AIR VALVE

ACCESS HOLE STRUT REMOVAL

LANDING GEAR FAIRING TYP.  
FOR VERTICAL VENTRAL  
FINS. WING TIP FAIRINGS  
SIMILAR BUT CIRCULAR IN  
CROSS SECTION

WHEEL RETRACTS IN FLIGHT TO  
POSITION SHOWN BY HYDRAULIC  
PRESSURE ON LWR. FACE OF  
UPPER PISTON BEARING.  
(SEE DETAIL C.)

DISPLACEMENT TYPE, HIGH SPEED  
HYDRAULIC MOTOR (5 HP) WORKS  
GEAR DRIVE TO DRUM. REDUCTION  
RATIO 208:1 WILL ERECT AIRPLANE  
IN APPROX. 2 MINUTES

SINGLE CABLE LOCK RELEASE  
SPRING RETURN

DETAIL FOLDING VENTRAL FIN  
AND LANDING GEAR

Figure 3.3.5.4.14 Detail of Folding Ventral Fin - Lockheed CL-295-4  
Self-Erecting Airplane (Courtesy Lockheed Corporation)

The CL-295-2 airplane was basically an enlargement of the CL-295-4 design except that the CL-295-2 wing had less sweep and the airplane used twin vertical tails. The relatively heavier J79 engines of the CL-295-2 allowed a more aft center of gravity location, desirable for ground stability. The wing could be effectively moved aft by reducing the sweepback used in the CL-295-4 design, without exceeding the aft limit of trailing edge distance from the ground set by exhaust gas impingement effects. Because the more aft center of gravity would have required an inordinately large single vertical tail for satisfactory stability and control, twin vertical tails were used. They required less area, but increased the number of undercarriage units to five from four.

The stability and control characteristics of the CL-295-2 design were expected to be similar to those of the CL-294-4. Speed, as with the other designs was restricted by engine limitations with  $M=2.2$  being the maximum permitted above 35,000 ft. The CL-295-4 engine was to have permitted  $M=2.5$  above 40,000 ft.

#### Concluding Observations

1. Of the Day Fighter studies made by Temco, Convair, Lockheed and Ryan, Lockheed's appears to be the most extensive, covering both dependent and independent aircraft types well. Lockheed provided an excellent assessment of the VATOL concepts.

2. A number of Lockheed's conclusions are worthy of attention. These are:

A. The lightest VATOL aircraft is a dependent (hanging) type, and the optimum configuration is a relatively conventional, straight-wing, single-engine aircraft (similar to the F-104) with a belly hook for engaging a ground-based cable system.

B. The tail-sitter without integral self-erecting means was in actuality a dependent aircraft which required at least as much ground support equipment as the hanging type VATOL airplane. The hanging type is to be preferred.

C. The optimum configuration for an independent VATOL airplane is a twin-engine canard-equipped ("tail-first") design with undercarriage units mounted at the tips of the wings and vertical fins. A power-operated folding ventral fin provides an effective tilting means for the airplane.

D. The dependent airplane, with a 1960 era turbojet engine (Wright TJ32C4), had a zero fuel weight only 10.5 percent more than the F-104 conventional fighter and could out-perform the F-104 in every capability as a fighter except combat radius.

E. The most feasible launching and recovery system for the dependent aircraft utilized a hook on the airplane to engage a cable system supported from the ground. The cable apparatus can be designed to be air transportable and set up in a few hours.

F. The major problem in providing low speed-vertical mode flight control was to devise control methods which do not impose high weight or thrust penalties. Lockheed selected the system of air-cooled, retractible vanes in the engine exhaust and jet nozzles at the wing tips, powered by engine compressor bleed air.

G. Stability at low speeds could be augmented by a three-axis autopilot, but the airplane could be designed to be safely controlled without the autopilot. The autopilot was worthwhile because it relieved pilot workload and improved roll-yaw stability in high speed flight.

H. There were no major technical obstacles to the practical and straight-forward development of a VATOL fighter as part of a weapon system. Some of the problems were "formidable" but none were of a fundamental nature. The general direction of the required development work was known. Some of the solutions developed for the VTOL airplane would have application to other advanced aircraft designs.

3. According to Lockheed the most pressing needs in developing VATOL aircraft are:

A. Information and data on the basic aerodynamic characteristics of the airplane configurations and component parts at angles of attack beyond stall and up to 90 degrees.

B. Development testing to optimize the design of the segmented boundary layer control system for control of the stall pattern.

C. Development work, mechanical and aerodynamic, on the "free-floating" canard control system. This was considered to be essential to the development of the independent VATOL airplane.

D. A strong development effort on the low speed control system to permit finalizing its design. The vane system was expected to require extensive development work with regard to optimal vane shape, cooling, material and mechanical reliability at high temperature.

E. Development of satisfactory information sensors to supply required inputs to the pilot or autopilot of the aircraft's vertical motion and position in space. Such information is a prime need because operation of tail landing aircraft is difficult for the pilot when flying from essentially an on-his-back position.

F. A general investigation into the landing and take-off problem to determine flying qualities needed and means for obtaining them.

G. For the VTOL airplane engine specific attention to areas such as: accessory cooling in low speed flight, means for increasing bleed capacity at low powers, and provision of a smooth, continuous variation in thrust from military up to maximum afterburning power with quick response to throttle movement. Specifically, the thrust range just above military power was important in the slow-down transition, hovering and landing maneuvers.

4. While the foregoing is a good summary of the status and problems involved in VATOL airplane development, the following additional points need to be made:

A. Lockheed did not compare total system costs of the dependent and independent VATOL aircraft since this was not part of the contracted study. The conclusions regarding which airplane approach is best can only be made after such cost comparisons are available. Future studies should include total system costs.

B. Lockheed did not consider the possibilities of increasing VATOL fighter capabilities through use of running take-off for either the dependent or independent types. The latter might be able to use a variant of the erecting undercarriage modified to permit running take-off. The dependent airplane could make use of a landing gear pod or a ground handling cart designed to allow running take-off. Such operations could provide the short take-off and vertical landing (STOVL) capability presently (1985) being given serious consideration.

C. Before extensive development work is started on the vane-in-engine exhaust control system an in-depth investigation of alternate methods should be done. Other methods of thrust vectoring, based on today's (1985) technology, may cause lower thrust loss and have better reliability and safety. Means for getting roll control through the engine thrust vectoring system instead of by reaction jets at wing tips need to be considered, particularly in twin-engine designs.

D. Handling characteristics of the twin-engine (independent) aircraft were not addressed for the one-engine-out condition in critical flight mode. Neither were consequences of failure of a control vane discussed. These are important design considerations. It is highly desirable that attitude control be available to the pilot after an engine failure in low speed-vertical mode flight.

E. VATOL aircraft, which use thrust vectoring for pitch and yaw control and horizontal translation in vertical flight, will initially move oppositely to the desired direction before vehicle tilt causes desired translation. Because of this effect Lockheed's independent airplane designs, canard types with more aft center of gravity than the dependent designs, may have more difficulty in being precisely maneuvered during hovering flight to hold a position.

F. With regard to being able to fly at low speed and in vertical mode flight without autopilot (item 2G above), this will be true only if engine gyroscopics are relatively small. Such gyroscopics cause cross-coupling of airplane motions and unexpected airplane pitch and yaw responses to conventional movement of control elements. The X-13 was unflyable without autopilot because of engine gyroscopics.

G. Lockheed's assertion (2A above) that a straight wing was optimum for a VATOL fighter may not be correct. Modern supersonic speed fighters do not use such a planform today (1985).

H. It is not necessarily correct (2C above) that the optimum independent airplane will have a canard configuration. The self-erecting Focke-Wulf FW-860 design used a delta wing configuration.

I. The jet nozzles of the self-erecting airplane designs were only 2 feet above ground in tail sitting position. Lockheed, in their summary report (Reference 3.3.5.5), did not discuss the problem of potential damage to the airframe due to jet impingement on the ground nor the jet blast effects on the ground itself and precautions necessary. These are important considerations affecting the design and operation of VTOL aircraft.

3.3.5.5 Ryan Aeronautical VATOL Aircraft Designs (1954-1957)

Ryan Aeronautical's interest in vertical attitude take-off and landing aircraft actually started in 1947 when they realized that the developing jet engines had sufficient thrust and low enough weight to directly lift airplanes vertically with meaningful payloads. A vigorous effort to design, develop and prove the potential of VTOL fighters, based on the vertical attitude approach, was pursued by the company until the U.S. Air Force decided against VATOL in favor of HATOL (Pell XF-109A) in 1957. Ryan subsequently shifted their interest to HATOL leading to their involvement in lift fan concepts and culminating in the XV-5A.

During the 1954-1957 time period Ryan engaged in four major studies which produced VATOL aircraft designs designated Model 84 (and 84F-7, a turbofan version of 84), 112, 115 and 115C. The 84 and 84F-7 were preliminary Light Day Fighter designs deriving from a broad study of a number of different VATOL configurations. Model 112 was a detailed design study of a "Visual" fighter based on the Model 84. Models 115 and 115C essentially were redesigns of the Model 112 to meet new Air Force requirements for a Dispersed Site Fighter-Bomber. All used various versions of the General Electric engines (J-79 and others with afterburning (A/B)) then under development. Models 84 (and 84F-7) and 115 were generated under Air Force contract; Ryan used their own funds for the 112 and 115C design work.

Ryan Model 84 (1954-1955): Information on the study which resulted in Model 84 was found in Reference 3.3.5.6.

The effort which led to the Model 84 design started with Ryan's receipt of Air Force Contract No. AF18(600)-1157 in 1954, one of four let to industry to determine a desirable configuration of a VTOL Day Fighter. These study contracts were initiated shortly after the X-13 effort had been started and the studies were performed while it was under construction.

During their previous Navy-sponsored efforts Ryan had analyzed a wide range of VTOL approaches and concluded that the HATOL types were inferior to the VATOL ones. Further, their analyses showed the hanging (hook-suspended) VATOL aircraft to be preferable to tail-sitters including those having a "kneeling" capability. Even after the disadvantages of pilot position during VTOL and special ground equipment necessary were considered, the hanging type still was preferred strongly because it had the least aircraft configuration compromise, best aerodynamic cleanness, lowest empty and gross weights, and minimal jet blast effects on the ground and on recirculation. Regarding the use of STOL capability, Ryan Aeronautical's view was expressed in Reference 3.3.5.6 by their statement: "The short runway approach to VTOL suggested in

some quarters may be applicable to existing fighter types with various take-off assist and landing deceleration techniques, but is wholly out of place in new designs for day fighters to be operational in 1960." In essence, in 1955 Ryan did not give serious consideration to the merits of a running take-off as a means for increasing useful load over that possible with VTOL. (Later, in 1957, in an effort to satisfy Air Force desires, Ryan did design the Model 115C which incorporated an under-carriage for running take-off and landing.)

Ryan's philosophy was to design the VTOL fighter primarily for the airborne phases of the combat mission, keeping the compromises for take-off and landing to a minimum. The airframe weight saved (landing gear, wing flaps, etc.) was put into the additional propulsion needed by the VTOL fighter. The company concluded that this approach would permit the development of VTOL Light Day Fighters for use in the 1960's to meet the Air Force requirements shown in Figure 3.3.5.5.1. The specific approach was to use only a small, non-shock absorbing belly hook for take-off and landing. In addition, the ground rig, from which the aircraft operated, was equipped with blast deflectors which, when combined with the aircraft's height above the ground, eliminated ground blast and recirculation effects.

Ryan considered the most significant disadvantages of the hook-suspended concept to be: the logistic cost of moving the ground-based launching/landing and handling equipment and emergency landings away from the base. Based on their analysis the company believed the total life cycle costs to be lower for their hook-suspended fighter system than for VTOL aircraft which required a conventional landing gear, even after accounting for the costs of acquiring and delivering the ground apparatus into combat areas away from the U.S. Regarding emergency landings, the incidence of such during combat operations, where the ground apparatus could not be used, was estimated to be sufficiently low to outweigh the emergency landing merits of equipping the fighter fleet with conventional landing capability.

During the Model 84 study, Ryan investigated fourteen possible turbojet-powered, hook-suspended designs. Both single engine (Pratt and Whitney afterburning J-75, 23,500 lbs S.L. static thrust, 5300 lbs uninstalled weight) and twin-engine (General Electric afterburning J79-GE1, 14,350 lbs thrust, 3155 lbs uninstalled weight) configurations were evaluated. Since these engines were then under development, the 1955 demonstrated test stand thrust values were used. The best performing of the fourteen designs was one with side-by-side twin-engines in the fuselage, a low mounted delta wing and a conventional (tilting) seat as opposed to a prone position. Further refinement of the best of the single and twin engine designs showed the single engine to have only a 96 nmi radius of action, less than one-half of the required 200 nmi (2,000 ft, 90°F take-off). The twin engine design had a 219 nmi radius of action.

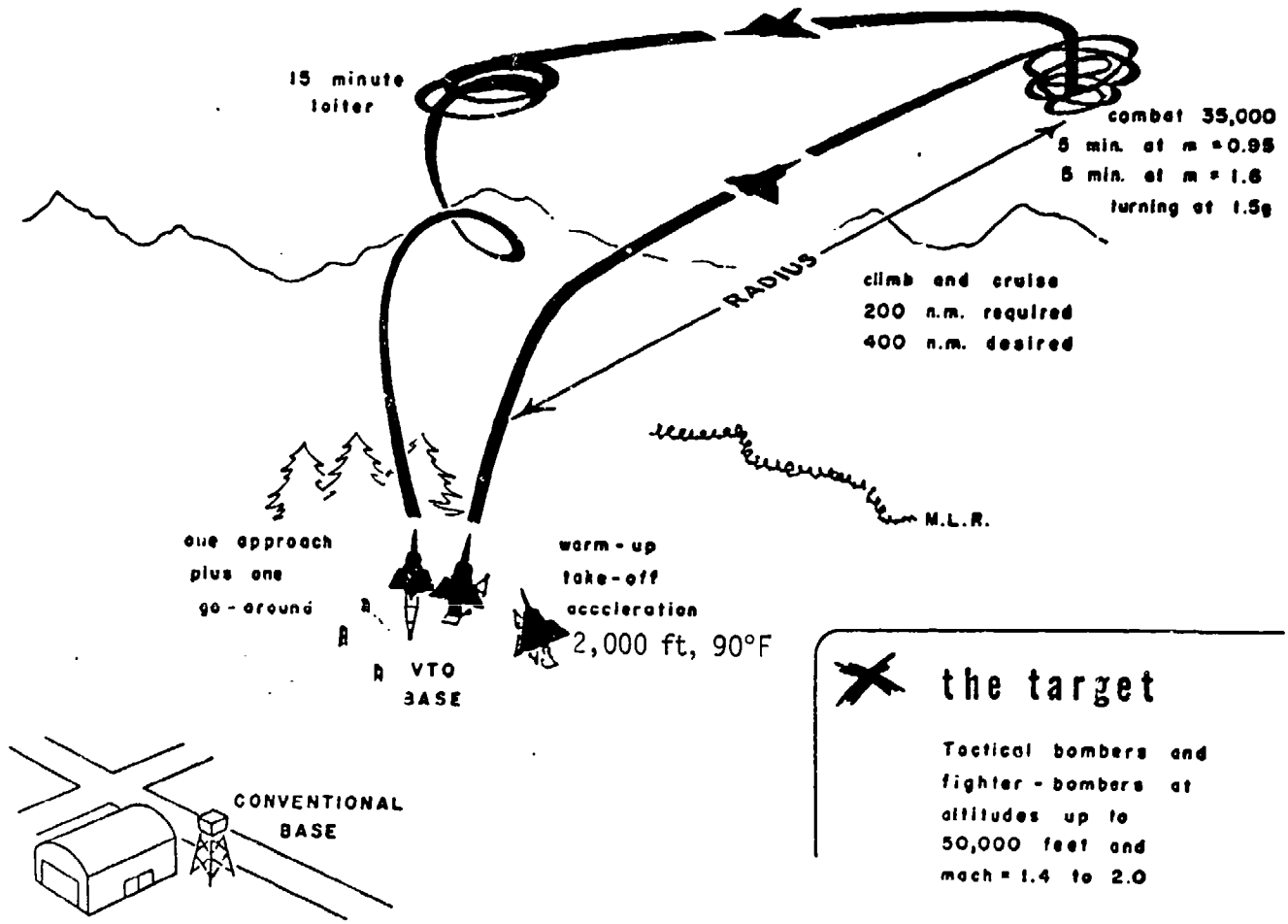

Figure 3.3.5.5.1 Air Force Light Day Fighter Mission Requirement (Reference 3.3.5.6)

A more thorough preliminary design effort on the twin-turbojet engine aircraft followed and resulted in the Ryan Model 84, which became the basis for a follow-on detailed design, the Model 112. Both Models 84 and 112 closely resembled Model 115 (Figure 3.3.5.5.3). The characteristics of Model 84 are summarized in the previously presented Table 3.3.5.2. Features similar to those used in the Model 84; air-frame aerodynamics, tilting seat, belly hook, flight controls, etc. were used in the Models 112, 115 and 115C.

In response to the Air Force interest in the potential value of the turbofan engines then being explored, Ryan also studied day fighter designs with General Electric turbofan-X84 and -X301 engines. As with the turbojet-powered designs a number of layouts (six) were made, both single and twin engine. Once again the twin-turbojet, powered designs proved to be superior. Ryan proceeded to perform a preliminary design of a scaled-up version of the Model 84 (designated Model 84F-7), equipped with two General Electric -X301 turbofan engines. A significant increase in performance was obtained over the turbojet-powered Model 84; combat radius was sizeably larger and altitude capabilities greater. However, because the -X301 turbofan engine was in the early stages of development, Ryan based their subsequent VATOL efforts (Models 112, 115 and 115C) on General Electric J-79 turbojet engine derivatives. 1963 to 1966 was projected as the operational date for the -X301 engine; the J-79 was expected to be available at least 5 years earlier. Ryan believed the earlier availability of the J-79 to be of overriding importance to the introduction of VTOL day fighters into the inventory during the early 1960's. They did conclude, however, that when turbofan engines of the General Electric -X301 class were developed, VTOL aircraft could be designed with substantially greater capabilities than the turbojet-powered types. Based on the J-79 engine thrust and availability projections, Ryan's program analysis showed that a day fighter could be operational by 1961 if the development program was initiated during 1955.

#### Ryan Model 112 Visual Fighter Design

(1955-1956): As a result of the Day Fighter design study which identified Model 84 as the preferred solution, the Air Force sent a proposal request letter to Ryan (letter AC-251-2076-57). In response, Ryan undertook at their own expense an in-depth design effort based on the Model 84. The new design, now called a "Visual Fighter", designated Model 112, used two J79-GE-2 A/B engines (S.L. maximum thrust 17,000 lbs each). Aircraft weights were: empty 16,523 lbs; design VTO 26,727 (2,000 ft, 90°F). Only a limited amount of information was available on the Model 112 and was found in Reference 3.3.5.7. Models 115 and 115C essentially were designs based on Model 112. Many features of Model 115 were similar to Model 112.

#### Ryan Models 115 and 115C VTOL Fighter-

Bombers (1956-1957): The Model 115 design was generated under an Air Force contract study (Contract No. AF 18(600)-1641, June 1956) of a Dispersed Site Fighter-Bomber VTOL weapon system.

Model 115C was a revised version of 115, somewhat larger and with more performance capability, aimed at meeting updated Air Force requirements. One version of Model 115C was equipped with a tricycle landing gear. Extensive information on Model 115 is found in Reference 3.3.5.8, which summarizes the fighter bomber study effort, and in Reference 3.3.5.9., the Model 115 Airplane Design Summary Report. Unfortunately, only a limited amount of information on the Model 115C was available and was found in Reference 3.3.5.10.

The purpose of the Dispersed Site Fighter-Bomber study was to determine if such a system could be developed for operational use in the 1960's and to formulate a development plan. (Reference 3.3.5.11 gives the development plan.) Two fighter-bomber sizes were of interest; the primary one was an aircraft to provide a 450 nm radius of action (R/A) using optimum subsonic cruise. The other, a shorter range aircraft, was of lesser interest and was to be capable of 250 nm R/A. Table 3.3.5.5.1 and Figure 3.3.5.5.2 summarize the performance requirements. The aircraft were to be sized solely by the radius of action. The dash capabilities were not to enter into this sizing but were to be determined for the resulting aircraft to obtain the dash segments possible in meeting the specified radii of action.

TABLE 3.3.5.5.1

**PERFORMANCE REQUIREMENTS FOR DISPERSED SITE  
 FIGHTER-BOMBER (PRIMARY REQUIREMENTS)**

Takeoff and Landing	Vertical at 2000°, 90°F day with minimum dependence on specialized ground equipment
Military Load	1000 lb nuclear weapon, 18" dia, 60" long if carried internally, 180" long if carried externally. Alternate load: 4 sidewinder or GAR-1B type missiles
Speed	Mach 1.0 at S.L. (or 1000 fps if significant weight savings obtained) Mach 2.0 at 35,000 ft
Altitude	60,000 ft
Radius of Action (R/A)	Long Range: 450 nm with nuclear weapon. Short Range: 250 nm with nuclear weapon. (Following the rules shown in Figure 3.3.5.2.2)
Mission with M=1.6 Dash segment for total R/A of 150, 250 and 350 nm	Dash R/A - to be determined during design study
Mission with M=2.0 Dash segment for total R/A of 150, 250 and 350 nm	Dash R/A - to be determined during design study
Mission with Dash segment at low level and Mach=1.0 speed for a total R/A of 150, 250 and 350 nm	Dash R/A - to be determined during design study
Ferry Range:	
Refueled at Point of No Return	- 2142 nm
Refueled at Maximum Range Point	- 3600 nm

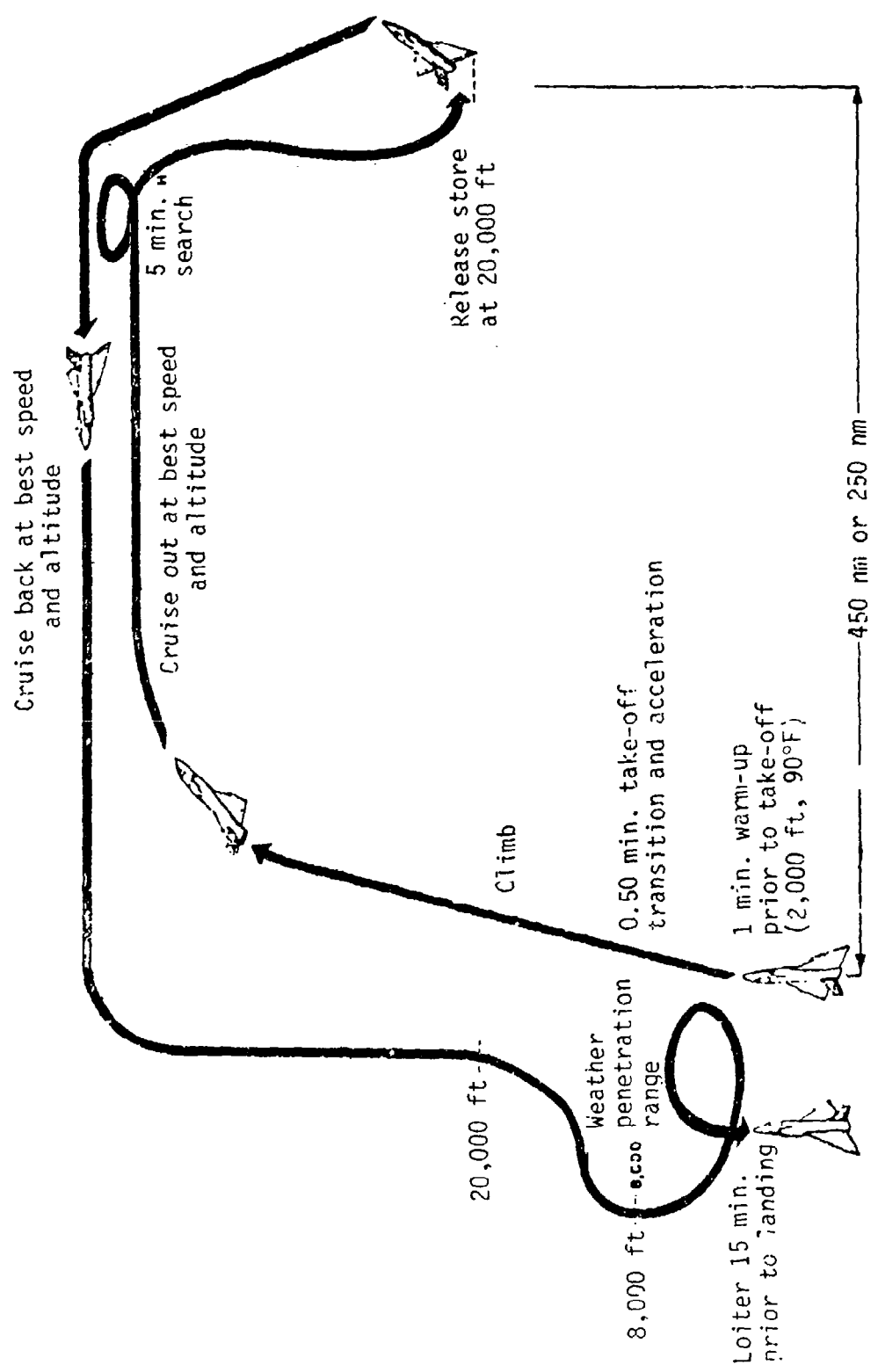

Figure 3.3.5.5.2 Air Force Dispersed Site Fighter-Bomber Basic Mission Profile  
(Reference 3.3.5.4)

Ryan considered the fundamental purpose of the study to be: (1) to establish whether a VTOL airplane with reasonable growth possibilities, capable of performing the specified primary mission, was immediately possible, and (2) to determine which of a wide variety of VTOL configurations would most effectively meet the specified Air Force requirements. For (1) Ryan elected to redesign their Model 112 day fighter into a fighter-bomber (Model 115) and to show that such an aircraft was immediately possible. The Model 115 design was used as a standard of comparison in (2).

Based on their previous studies of various VTOL concepts Ryan continued to believe that the hanging VATOL approach would provide the lightest, lowest cost, best performing VTOL fighter-bomber. However, as part of the contracted effort, the company undertook a reassessment of the various approaches to a VTOL fighter-bomber covering hanging, tail-sitter and HATOL types. (STOL operation of the latter was not considered; all operations were VTOL.) While it was a foregone conclusion that the hanging type would be the lightest, lowest cost airplane for equal performance, the unresolved question was the relative total weapon system cost since such aircraft required more special ground equipment than HATOL types. The cost of such equipment and its transportation entered into the total system cost.

Ryan's assessment (Reference 3.3.5.8) of the three basic VTOL approaches was that the HATOL aircraft would be heavier and more complicated than the other two. Since the differences in ground equipment required between the tail-sitter and HATOL favored the latter, it was expected that a total system cost comparison of hanging with tail-sitter types would determine whether further design and system cost analysis of the HATOL approach was needed. If the hanging type system cost was lower then no further effort on the tail-sitter or HATOL types obviously would be necessary.

To compare the relative weights of the hanging and tail-sitter types, use was made of a twin-engine hanging type airplane that previously had been designed in detail by Ryan and which could be readily modified parametrically to derive a tail-sitter of equal combat performance. The comparative weights, taken from Reference 3.3.5.8 are given in Table 3.3.5.5.2.

TABLE 3.3.5.5.2

WEIGHT COMPARISON OF RYAN HANGING AND TAIL-SITTER DESIGNS

	<u>Hanging Type</u>	<u>Tail-Sitter</u>
Empty Weight, lbs.	14,500	19,500
Fuel, lbs	8,400	10,800
Other useful load, lbs	1,400	1,400
Gross weight, lbs	24,300	31,700

The tail-sitter was estimated to be 1/3 heavier than the hanging type.

To obtain relative system costs, an operations analysis was conducted based on 72 Dispersed Site Fighter-Bombers operating for 30 days 5,000 miles from the continental U.S. with all equipment, fuel and other materiel being supplied by C-132 cargo and intra-theater STOL transports. The cost of the operations included the fighter-bomber, ground equipment, amortized STOL and C-132 transport airplane costs, the transport airplanes' operating costs, and fuel. For this combat operation costs were 24 percent higher with tail-sitters than with hanging aircraft (\$99,553,000 vs. \$80,040,000). This finding led Ryan to direct their further contractual efforts to the hanging VATOL fighter-bomber.

It should be noted that, in addition to the hanging and tail-sitter types, some HATOL airplane configurations also had been assessed. The most likely HATOL approaches were considered to be: deflection of flow from fixed attitude, fuselage-mounted engines; tilting engines; and tilt wing with engines buried inside the wing. As with the tail-sitter the HATOL concepts were judged to be heavier than the hanging type and, in addition, were considered to be more complicated aircraft. Performance was inferior to both of the VATOL types.

For the hanging VATOL design study several configurations with different numbers of engines (one, two, two small plus one large, and four or more small engines) were explored, primarily to assess the affect of the various engines, then under development, on airplane size and ability to meet the mission performance requirements. The engines considered ranged from 3,500 to 45,000 lbs static thrust (S.L. std day). Airplane design analysis showed that the engine thrust-to-weight ratio (T/W) had a great effect on the empty weight and on fuel required for the mission. Highest T/W was provided by the afterburning J85 (thrust 3,500 lbs, T/W = 8.6); this engine was used in the aircraft designs with three engines and with four or more engines. Of the larger engines the afterburning J79-GE-X207 (thrust 18,000 lbs, T/W = 5.4) was preferred because it was reasonably certain to be available in 1960 and had a good T/W. Further, more advanced derivatives of the J79 being explored by General Electric, such as the J79-GE-X275A, opened up the possibility of appreciable growth potential to J79-GE-X207-equipped VTOL aircraft recommended for development by Ryan.

Two important factors in the operational cost are airplane empty weight and the amount of fuel required. Empty weight (E.W.) was used as a direct measure of airplane cost; E.W. also affected the weight, cost and logistic aspects of the necessary ground support equipment. Beyond its direct cost, the fuel used also entered into the logistic costs

because it was part of the materiel to be air transported to the dispersed site combat area. The parametric study of the different hanging VATOL configurations, using engines sized for the primary interest 450 nm radius mission (2000 ft, 90°F take-off), resulted in the airplane empty weights and fuel loads shown in Table 3.3.5.2.3

TABLE 3.3.5.5.3

RYAN AERONAUTICAL ESTIMATES OF WEIGHT EMPTY AND FUEL  
 REQUIRED FOR THE PRIMARY INTEREST MISSION,  
 HANGING VATOL AIRCRAFT DESIGNS

<u>Aircraft Configuration</u>	<u>E.W. lbs</u>	<u>Fuel Wt, lbs</u>
Single-Engine	-- <sup>1</sup>	--
Twin-Engine	14,800	8,200
Three-Engine (two J85's + larger central engine)	12,800	8,400
Multi-Engine (six J85's)	9,300	6,600
Single-Engine with Rocket Boost (3,000-4,000 lbs T) <sup>2</sup>	11,000	7,000
Multi-Engine (four J85's) with 2,500 lbs T Rocket Boost <sup>2</sup>	6,600	6,000

<sup>1</sup>No engine was available (1960) to permit design of a single-engine VTOL airplane capable of meeting the 450 nm cruise radius of action primary interest mission requirement.

<sup>2</sup>Rocket thrust duration - 30 sec.

Although these weights were approximate, not having been derived from actual preliminary designs, they provided a reasonable basis for aircraft comparison. The lightest of the configurations (not using rocket boost) was the six-engine J85; its empty weight was 37% less than the twin-J79-GE-X207 engine aircraft. The three-engine design weighed 13% less. Differences in fuel load, however, were less pronounced. Fuel load was nearly the same for the twin- and three-engine types, however, the six-engine design did use 20% less than the twin-engine. Despite the favorable empty and fuel weight of the six-engine airplane, Ryan believed the twin-engine to be a better choice because of its reduced complexity, higher reliability and the lower required development effort. Although the three-engine design was less complex than the six-engine, it had the disadvantage of using two types of engines in the same operational unit, resulting in increased

maintenance and supply problems. This lead Ryan, again, to favor the twin-engine configuration.

An important revelation of the design analyses was the large difference in radius of action capability for each aircraft between design take-off weight (2000 ft, 90°F) and the maximum take-off weight (S.L. std day condition). This was due to the difference in fuel which could be lifted. Since a substantial reduction in airplane size was possible if it could be designed for S.L. std day conditions, a short period take-off thrust boost offered interesting possibilities. This thrust boost could be provided by water injection, temporary use of high energy fuels, special booster turbojet engines, or by rockets. Ryan preferred rockets because they had the highest possible T/W. The affect of rocket boost (30 second duration) is shown in Table 3.3.5.5.3. A single-engine aircraft using an available (1960) engine, capable of meeting the 450 nm radius of action, now became possible; its empty weight was 11,000 lbs. If the rocket was used on the multi-engine configuration, the number of J85's could be reduced from six to four and the empty weight dropped by 29%. The rocket-boosted designs also showed logistic cost advantages as follows:

Twin-engine vs. single-engine with rocket boost:  
19% lower cost per fighter-bomber wing

Six-engine vs. four-engine with rocket boost:  
4% lower cost per fighter-bomber wing

However, the reduction in required turbojet engine-thrust with take-off rocket boost had a negative effect on climb, maneuverability and altitude performance compared with the heavier airplane powered solely by turbojet engines and capable of taking off under the same altitude/temperature conditions. Because of the decrease in overall performance, coupled with the operational problems involved in the use of thrust boost systems, Ryan preferred the non-boosted approach.

In addition to the primary 450 nm R/A subsonic cruise mission capability specified by the Air Force, the contract called for the analysis of aircraft designed for the less-important, shorter (250 nm) R/A mission. It was found that a single J79-GE-X207 engine airplane design could meet this R/A but that the aircraft was extremely limited in dash capability compared with the 450 nm design. Speeds of Mach 2.2 (engine operating restriction) up to 51,000 ft and service ceiling of 64,000 ft could be obtained, essentially matching the speed and altitude capability of the larger twin-engine airplane, but a mission with supersonic cruise at altitude had a negligible R/A. An all-low-level dash mission at 1000 fps speed had only a 74 nm R/A; 150 nm was required.

Both the single- and twin-J79-GE-X207-equipped airplanes (with no rocket boost) were capable of meeting the ferry range requirement for refueling at point of no return. For refueling at the maximum range point, the twin-engine design almost met the requirement; the single engine range was shy over 800 miles. The estimated ferry range figures appear below for take off at 2000 ft, 90°F:

	<u>Specified Value</u>	<u>Twin Engine</u>	<u>Single Engine</u>
Refuel at point of no return, nm	2142	2610	2348
Refuel at max. range, nm	3600	3400	2784

Ryan Model 115/115C Characteristics:

Figures 3.3.5.5.3 and 3.3.5.5.4 show the close physical relationship of the 115C to the 115. The principal changes made to obtain the 115C were the lengthening of the fuselage by nearly six feet to provide a longer weapon bay; the placement of the cockpit further forward of the wing resulting in a higher fineness ratio fuselage; the use of circular air inlets for the engines instead of semi-circular; the use of a lower aspect ratio, larger area vertical tail; and the use of J79-GE-X207A engines instead of the -X207 version. The -X207A engine had slightly more thrust allowing a 400 lb greater airplane take-off weight at 2000 ft, 90°F. Further, a 115C variant had provisions for installation of a tricycle undercarriage in addition to the belly hook. The 115 had no undercarriage provisions and used a trapeze-type hook-on device instead of a belly hook. Performance-wise, both designs were capable of reaching about the same altitudes (over 60,000 ft) but the maximum speed permitted for the 115C was Mach 2.5 compared with 2.2 for the 115. In both cases the speeds were limited by permissible temperature in the engine. The J79-GE-X-207A permissible temperature was higher than that of the -X-207.

The characteristics discussed in the following are those of the 115C, it being the final and most advanced design in the progression from Models 84 through 112, 115 to 115C.

The twin-J79 afterburning engines were mounted side-by-side in the fuselage above the wing which was located at the fuselage bottom. Extensive use of light gage stainless steel corrugated structure was to be made in the airframe to save weight and handle high temperatures from the engine and aerodynamic heating. The fuselage shape was area-ruled and the wing used a notched delta planform with 60° leading edge sweepback, the delta planform being chosen because of its favorable transition flight characteristics and suitability for meeting the high speed and high altitude requirements. Location of the wing at the fuselage bottom provided the best compromise between structural efficiency and aircraft stability.

WINGS 63A005  
 AIRFOIL SECTION 38  
 AVERAGE THICKNESS 04  
 INCIDENCE 04  
 DIHEDRAL 420 sq ft  
 AREA (TOTAL) 530 sq ft  
 ELEVON 248 sq ft  
 EACH (AFT OF HINGE) 40° up 20° down  
 ANGULAR MOVEMENT

VERTICAL TAIL 63A005  
 AIRFOIL SECTION 59.5 sq ft  
 AREA (TOTAL) 11.1 sq ft  
 RUDDER 25° left-25° right  
 AREA (AFT OF HINGE) ANGULAR MOVEMENT

DIVE BRAKE 12.5 sq ft  
 AREA 80° down  
 ANGULAR MOVEMENT

WEIGHTS\*  
 EMPTY 16,471 lb  
 DESIGN USEFUL LOAD 12,443 lb  
 TAKE OFF 28,571 lb  
 MAXIMUM GROSS 28,914 lb

ENGINE MODEL DESIGNATION J-79-GE-X207  
 \*2000 ft., 90°P

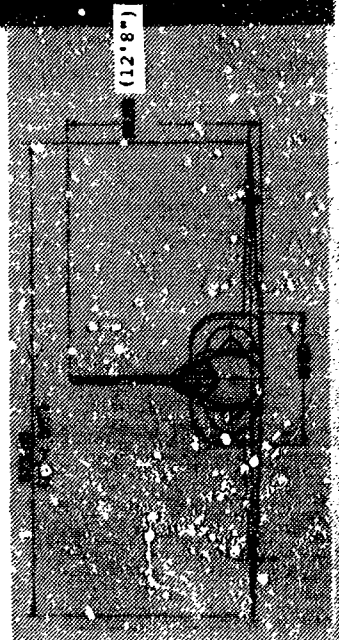
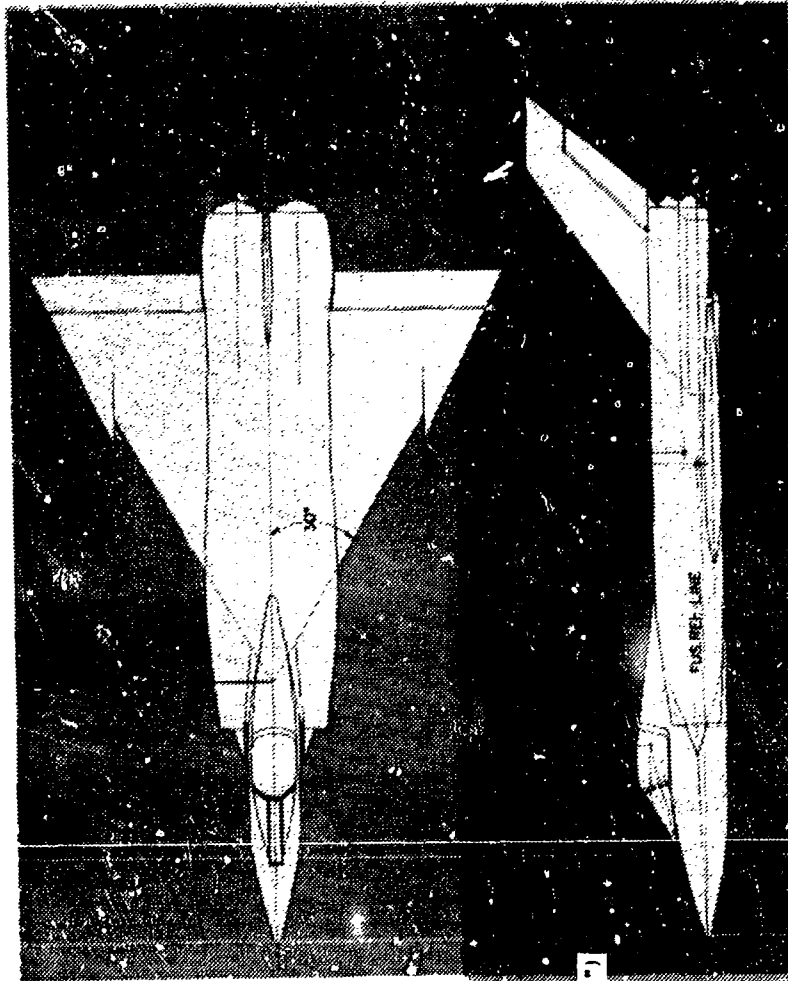
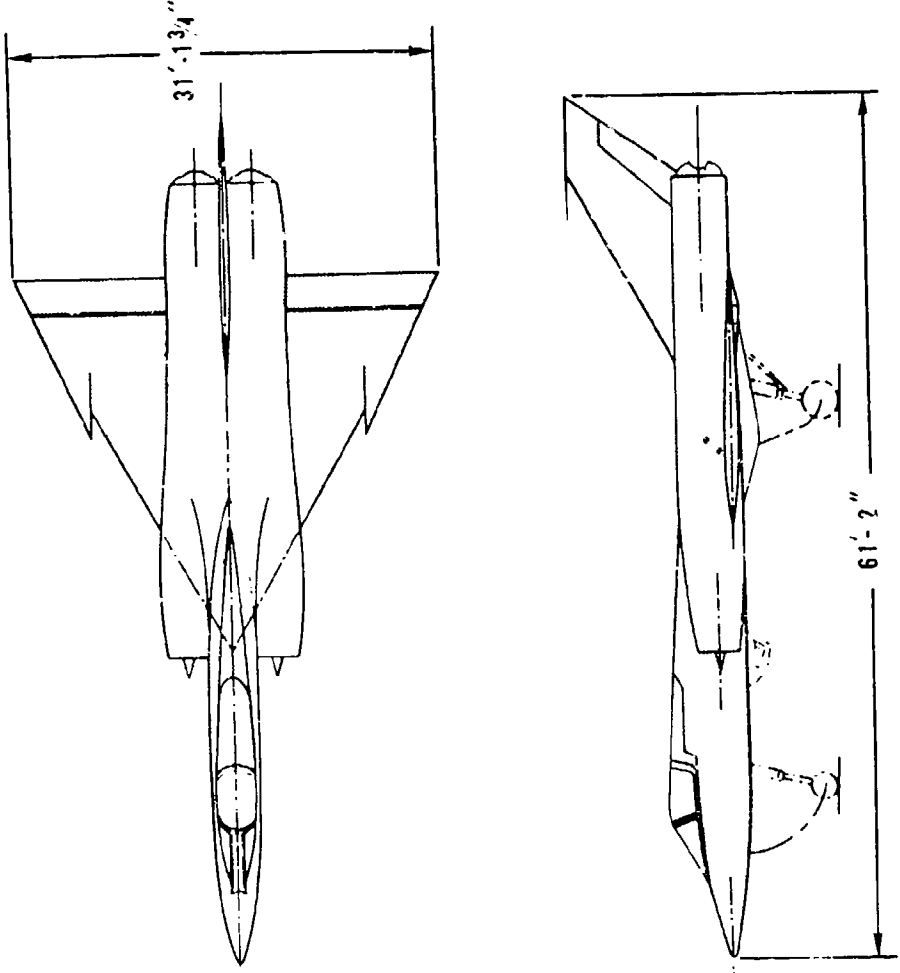

Figure 3.3.5.5.3 Ryan Model 115 Dispersed Site Fighter-Bomber 3-View  
 (Courtesy Teledyne Ryan Aeronautical)



Weights (L3)

Empty	17,685
Design Useful Load	11,265
Take Off	28,630
Maximum Gross	28,970

Engine Model Designation J79-GE-X207A

Figure 3.3.5.5.4 Ryan Model 115C Dispersed Site Fighter-Bomber, 3-View  
(Courtesy Teledyne Ryan Aeronautical)

The 115C's circular engine inlets were each provided with a fore-aft moveable spike. This controlled the position of the oblique shock wave with respect to the inlet lip at supersonic speeds. Control of the mass flow entering the engines at such speeds was provided by sliding by-pass doors. At subsonic speed the spike was positioned for a mass flow of unity at maximum engine rpm. At reduced rpm the by-pass doors dumped excess inlet air past the engine into the engine compartment to aid cooling. Provision was made for auxiliary air to enter the inlet ducts during vertical flight. As evident in Figure 3.3.5.5 the afterburning ducts terminated in spherically-shaped, variable area nozzles, gimballed for thrust vector control.

The flight control system was a refinement and modification of that developed for the X-13. Conventional aerodynamic surfaces (elevons and rudder) provided flight control above transition speed and jet reaction forces at the tail were used during vertical through transition mode flight. Both control systems were actuated by conventional stick and rudder pedals through an electric system and a fully-powered, irreversible hydraulic system; artificial feel was incorporated.

Control during vertical flight was accomplished by engine exhaust deflection and thrust variation. A thrust-to-weight ratio of 1.05 was used to permit pitch, roll and yaw control while accelerating vertically. It is probable that the control powers used exceeded the minimum values specified by Ryan for their Model 112 design (Reference 3.3.5.12). These were: 1.29 rads/sec<sup>2</sup> pitch, 1.39 roll, 2.65 yaw. Pitch control was by simultaneous deflection of both nozzles in the pitch plane with roll control being provided by differential deflection. Lateral nozzle deflection produced yawing moments. Control of height and vertical speed was by thrust variation through throttle movement. During transition flight both thrust deflection and aerodynamic controls were used simultaneously with the former being phased out as conventional attitude was approached.

An integrated stability augmentation system was provided for use in all flight regimes. Pitch and yaw stabilization during vertical through transition flight was based on signals from rate gyros to provide damping and inputs to lag rate integrators which gave approximate attitude references. Translational flight in vertical attitude was produced by bodily tilting the aircraft in response to stick deflections.

Compensation to overcome engine gyroscopic cross-coupling effects was through the provision of lead signals from the pitch and yaw commands and cross-feeding these signals into the complementary control channels.

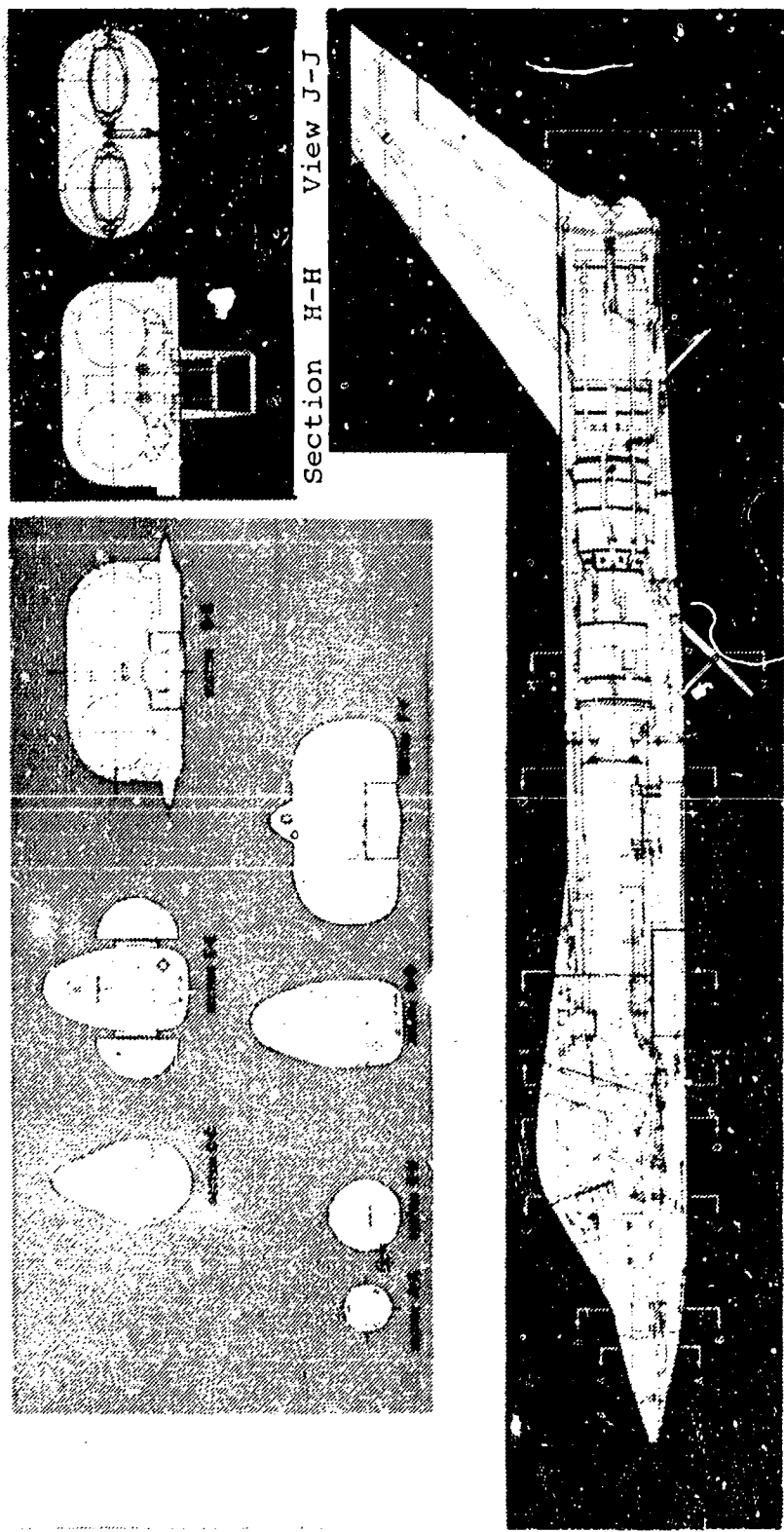

Figure 3.3.5.5.5 Ryan Model 115 Dispersed Site Fighter-Bomber Inboard Profile  
(Courtesy Teledyne Ryan Aeronautical)

Roll stabilization was based on a rate gyro which provided dynamic damping and, also, signals to a roll rate integrator for roll attitude reference. During vertical/transition flight the foot pedals produced roll control. The integrator was neutralized when the pedals were deflected, resulting in steady state roll rates.

Thrust control was modified by an acceleration feedback through a lag rate integrator to maintain comanded velocity constant along the airplane's longitudinal axis.

For conventional flight, artificial damping was incorporated about all three axes. The conventional flight stability augmentation system used the components already available in the vertical attitude flight system to provide the necessary damping. Mixing networks permitted control as required.

A number of other subsystems functioned within the integrated control system. A listing of the subsystems involved follows:

Stability augmentation system	Air data computer
Vertical stabilization system	Cruise trim control system
Autopilot	Fuel management system
Landing computer	Inertial navigator
Fire control system	Mapping radar

The 115C was to have all-weather capability featuring instrument take-off and landing, inertial navigation to and from the target and a fire control system using infrared and radar tracking.

Figure 3.3.5.5.5 is the Model 115 inboard profile; the one for the 115C was not available. Shown are the 45° tilting pilot's seat, the weapon bay for a 1000 lb nuclear weapon or four sidewinder missiles, the trapeze type hook-on apparatus (instead of the belly-hook used on the 115C), the engine installation and the variable area, gimballed nozzles.

In an apparent effort to satisfy Air Force interest in aircraft capable of both vertical and horizontal, running take-off and landing, Ryan explored the effect of adding a conventional tricycle landing gear to the basic hanging VATOL airplane. Three configurations of the 115C design were evaluated, all having a S.L. std day VTO weight of 33,737 lbs with 1,000 lbs of ordnance. (Note, the 115 VTO weight under similar conditions was 32,900 lbs.) The configurations were:

Configuration I - Had provisions for both horizontal and vertical take-off and landing. A conventional retractable tricycle undercarriage and drag parachute as well

as the VTOL retractable belly hook were provided together with the attendant internal airframe structure. For range extension this configuration could be overloaded with additional fuel (two 235 or two 400 gallon external tanks).

Configuration II - The tricycle undercarriage, its fairings and the drag parachute were removed to permit increased fuel load during VTOL. This configuration could operate VTOL only. Addition or removal of the undercarriage was intended to be done readily in the field.

Configuration III - This was the pure hanging VATOL type, without any provision for a conventional undercarriage and drag parachute. The airplane was optimized for VTOL operation and to carry the greatest VTO fuel load.

Figure 3.3.5.5.6 compares the weights of the major components of the three configurations. While all have the same VTO weight (33,737 lbs), their empty weights are different: I - 19,847 lbs; II - 18,330 lbs; III - 17,685 lbs. The penalty for the undercarriage is a 12% increase in empty weight over that of Configuration III, the pure VATOL design. From Figure 3.3.5.5.6 it is seen that provisions for CTOL (removable undercarriage and drag chute) absorb about 5% of the VTO gross weight and reduce fuel load by 15%, based on the unencumbered VATOL design (Configuration III). Comparison of the configurations in the table shows the radius and range gains achievable with running take-off of I and II in comparison with III operating VTOL. Specifically, it is seen that I operating CTOL with 470 gallons external fuel added ("Overload") has only a 6% radius increase (55 nm) over III's 900 nm radius of action. The unrefueled "Overload" ferry range, with 800 gallons external fuel, increases only 5.6% (102 nm). The maximum refueled ferry range for Configuration I carrying 800 gallons of external fuel is 4020 nm compared with Configuration III's 3880 nm, a modest 3.6% improvement. The penalty paid by Configuration I when operating VATOL from dispersed sites is a reduction in radius of action compared with Configuration III for the subsonic and supersonic missions shown in Figures 3.3.5.5.7 and 3.3.5.5.8. Figure 3.3.5.5.9 shows that Configuration I has nearly the same speed and altitude capability as III. With the landing gear removed (Configuration II) the capability is essentially equal to III. Configuration I requires 5-1/4 minutes to reach Mach 2.5 at 60,000 ft while II and III do this in 4-1/4 minutes.

The VTOL take-off and landing ground apparatus proposed for Model 115C is shown in Figure 3.3.5.5.10. It was designed to handle the 115C with or without a landing gear. With the landing gear attached, the airplane could taxi on to and off the device when in horizontal position. The apparatus was a completely self-contained unit which raised and lowered the 115C from horizontal to vertical

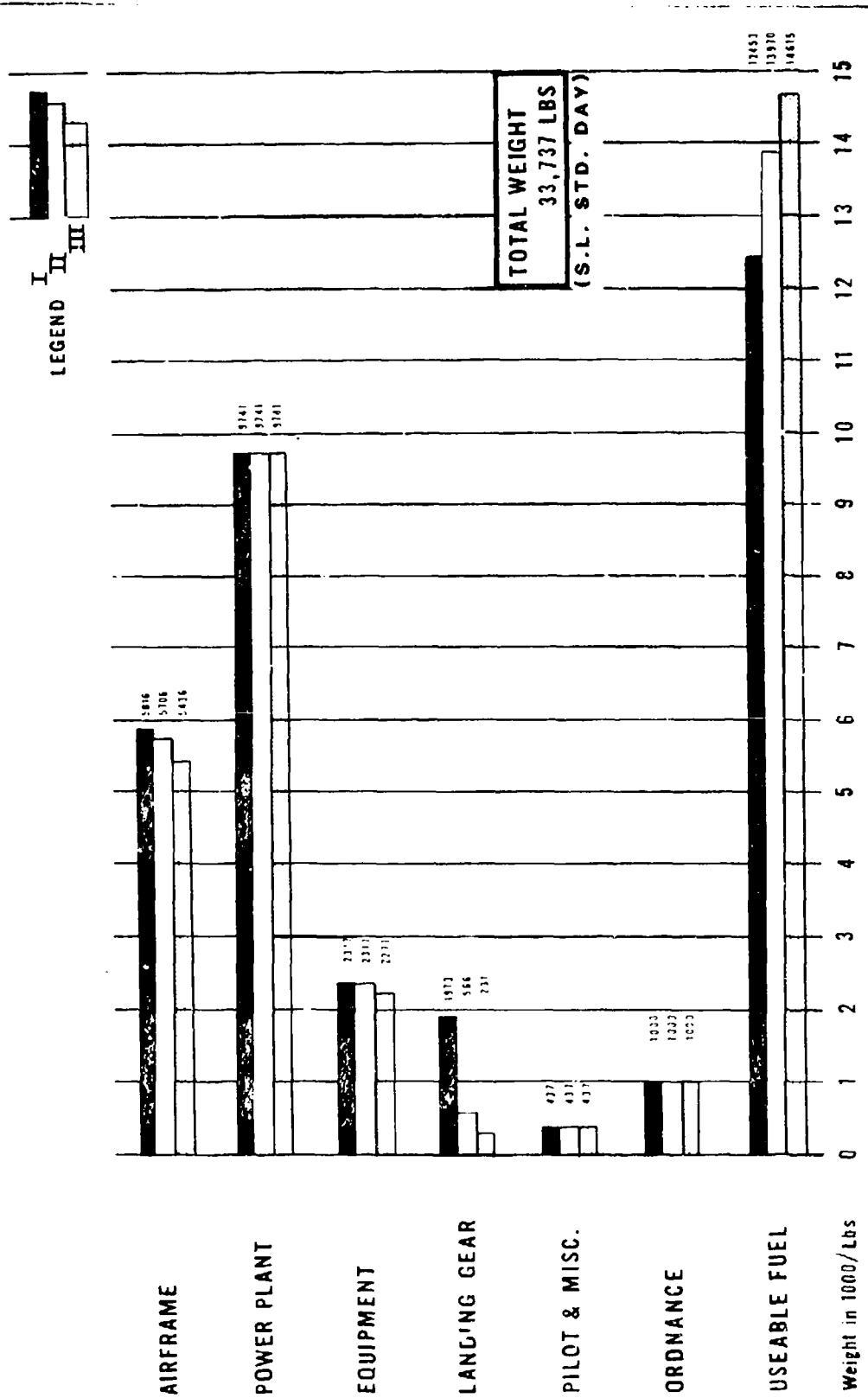

Figure 3.3.5.5.6 Weight Distribution for Three Configurations of the Ryan Model 115C Dispersed Site Fighter-Bomber (Courtesy Teledyne Ryan Aeronautical)

# DIVE TOSS DELIVERY 1000 LB. INTERNAL STORES

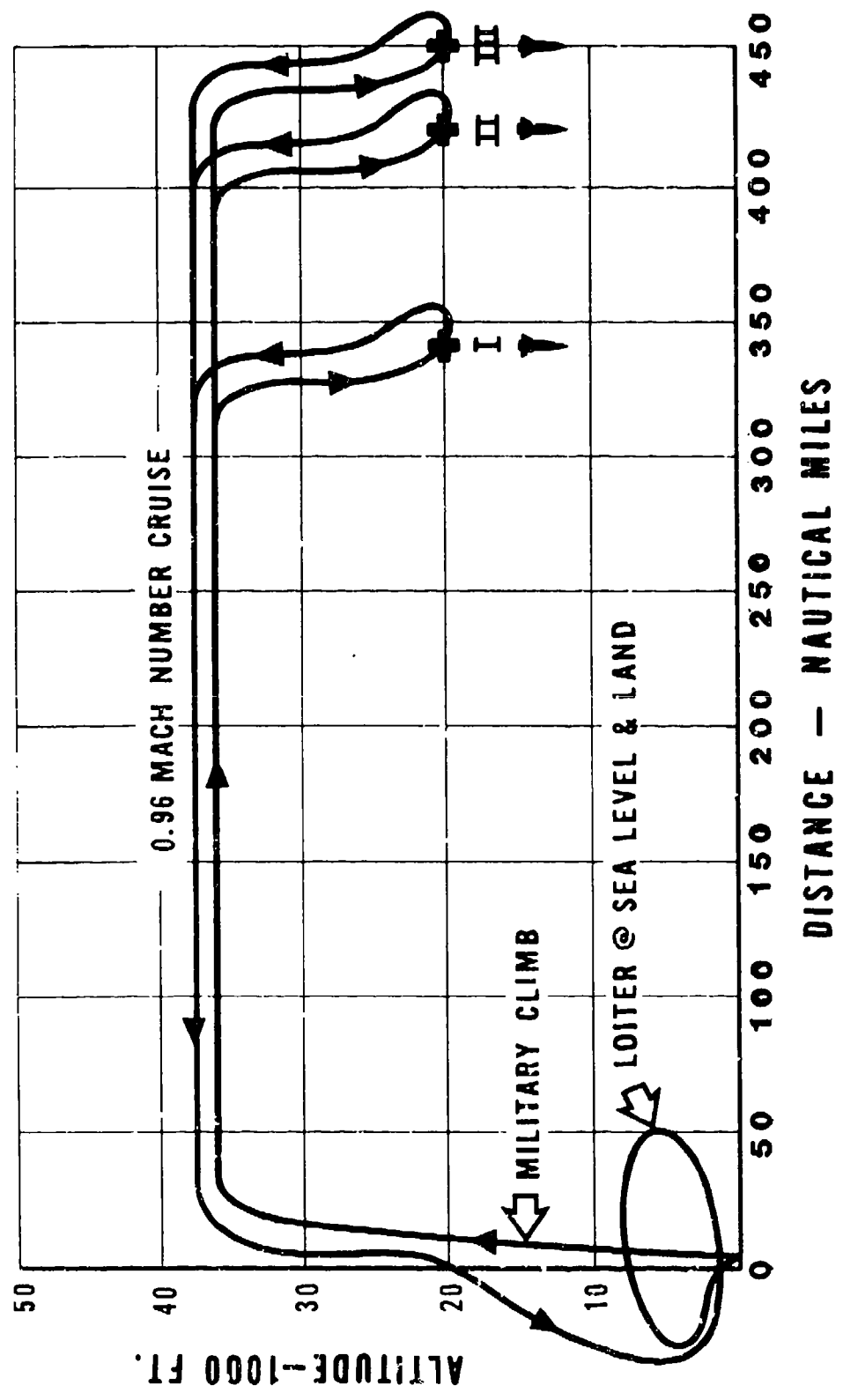

Figure 3.3.5.5.7 Basic Bombing Mission Profiles for the Three Configurations of the Ryan Model 115C Dispersed Site Fighter-Bomber (Courtesy Teledyne Ryan Aeronautical)

**DELIVERY 1000 LB. AIR-TO-AIR ORDNANCE (INTERNALLY STOWED)**

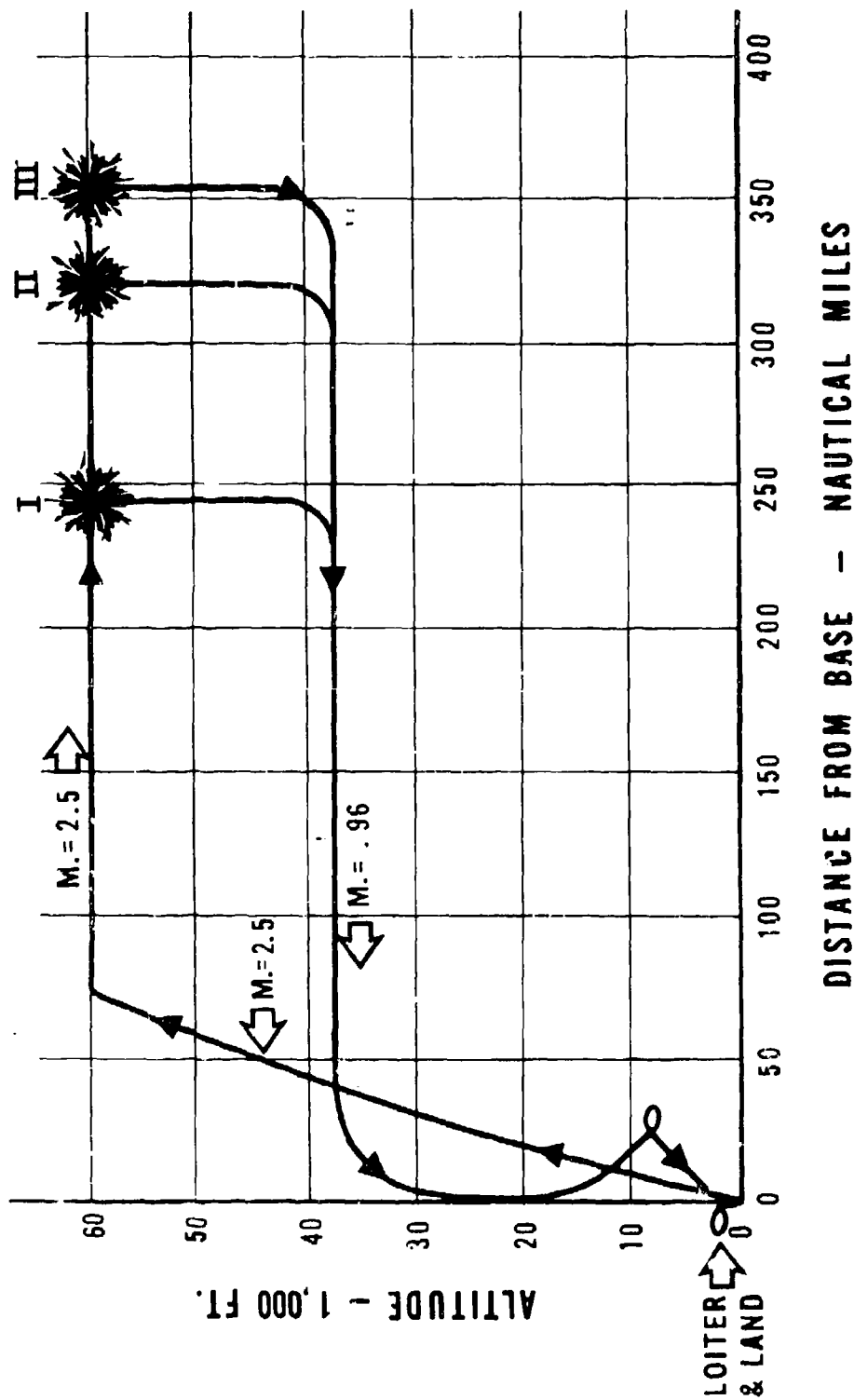

Figure 3.3.5.5.8 Point Interception Mission Profile (Single Head-On Pass) for the Three Configurations of the Ryan Model 115C Dispersed Site Fighter-Bomber (Courtesy Teledyne Ryan Aeronautical)

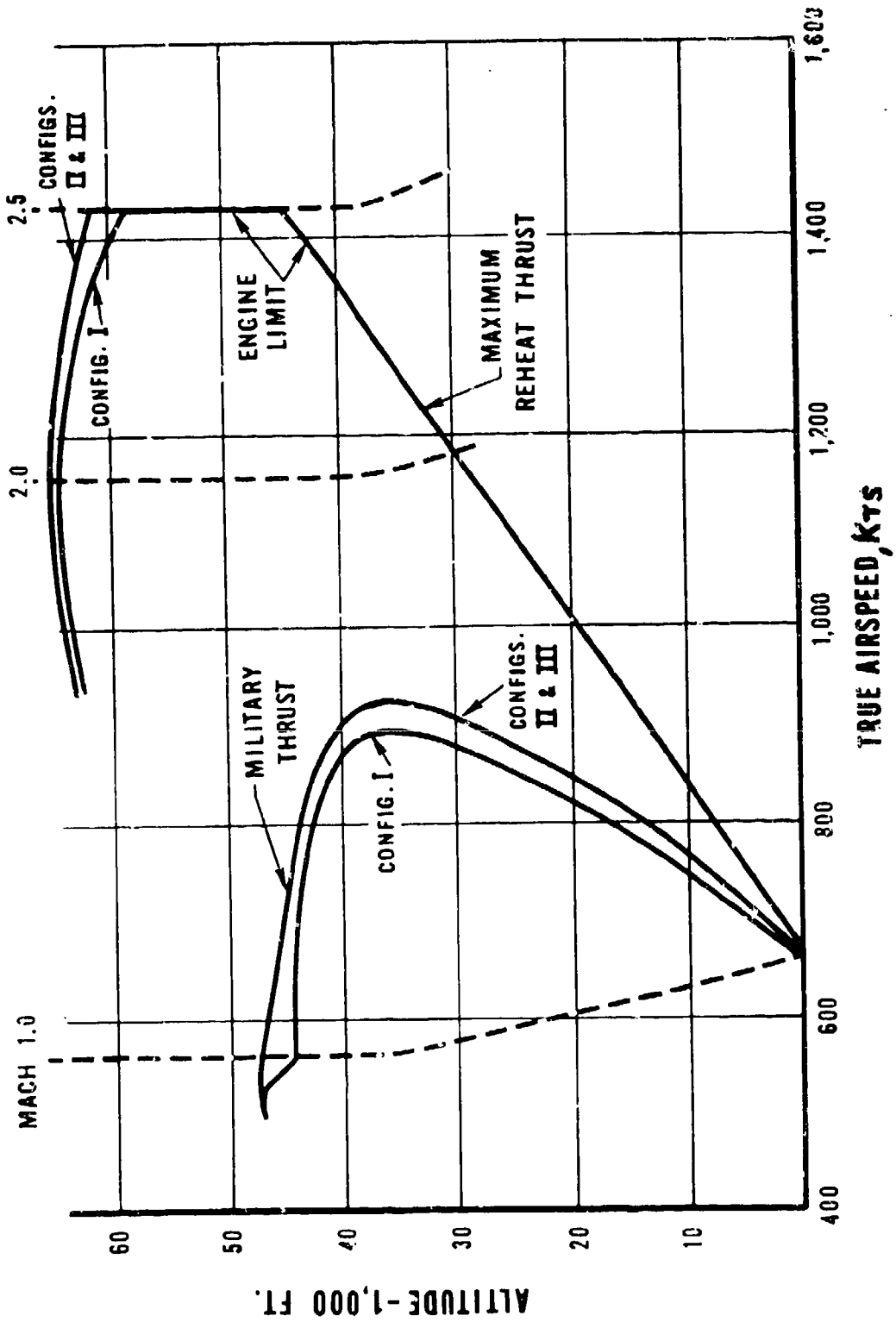

Figure 3.3.5.5.9 Maximum Airspeed Variation with Altitude at Combat Weight for the Three Configurations of the Ryan Model 115C Dispersed Site Fighter-Bomber (Courtesy Teledyne Ryan Aeronautical)

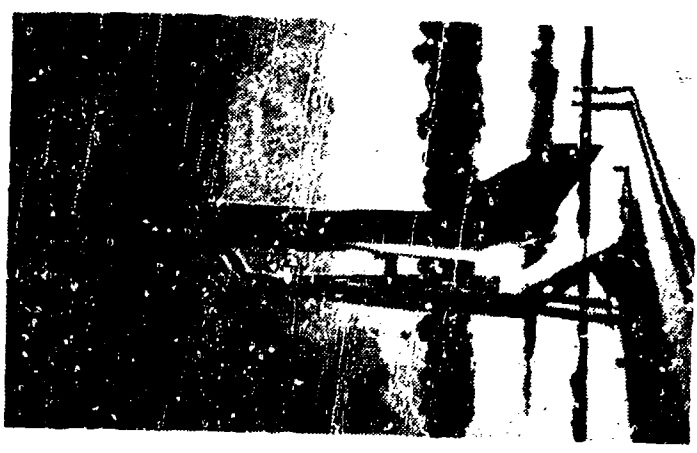
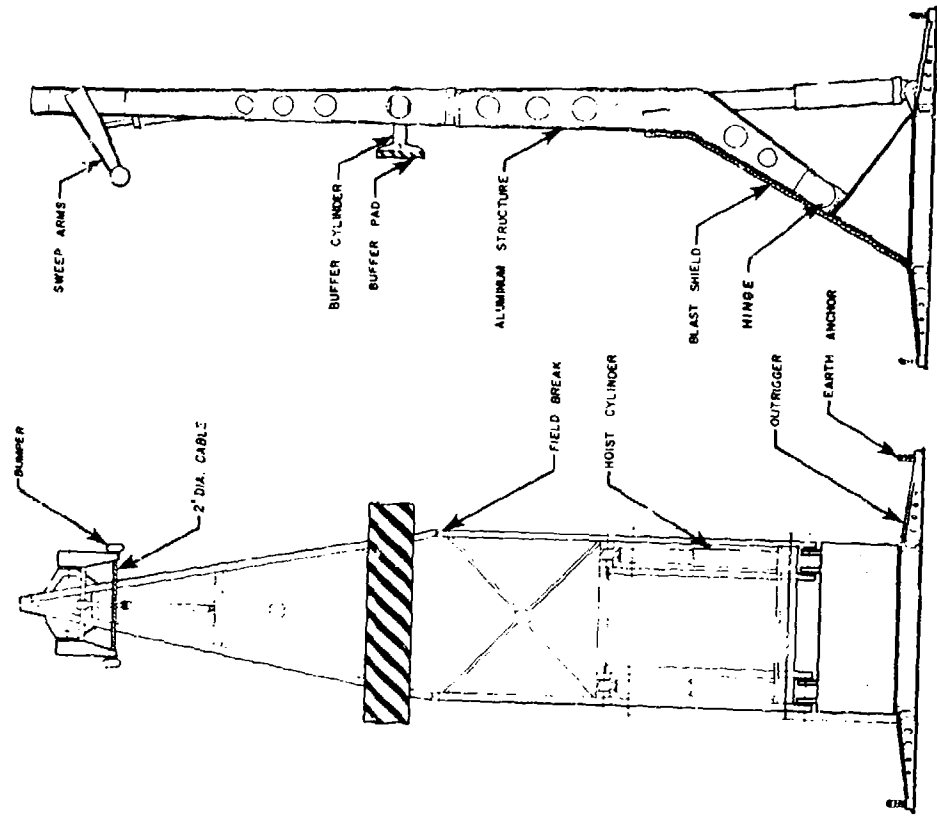

Figure 3.3.5.5.10 VTOL Take-Off and Landing Unit for the Ryan Model 115C Dispersed Site Fighter-Bomber (Courtesy Teledyne Ryan Aeronautical)

via a tilting motion and was equipped with an integral blast deflector. As in the X-13, a horizontal cable was used to engage the airplane's belly hook. Figure 3.3.5.5.11 shows how the ground apparatus is used. A ground cart permits the non-undercarriage-equipped airplane to be moved from place to place. The ground apparatus was designed for air transport and rapid anchoring to the ground.

Ryan believed that sufficient development had already been accomplished to resolve critical questions regarding the feasibility of the hanging VATOL aircraft and in December 1957, urged the Air Force to undertake the development. The Air Force elected to undertake a HATOL approach, the Bell XF-109 instead. Ryan's proposed Model 115C fighter-bomber development program schedule is shown in Figure 3.3.5.5.12. First flight was projected to be 2-1/2 years after go-ahead, with first production delivery of service aircraft estimated to be five years from the program start date.

#### Concluding Observations:

1. By 1957 Ryan had created a reasonable technical base for developing a high performance VATOL fighter. Such an effort could have been undertaken with a good chance of success.
2. Ryan's arguments in favor of the hanging VATOL fighter approach over the HATOL are interesting and appear to have merit, even today.
3. Even by current standards the predicted speed, altitude, rate of climb and maneuverability performance of the Model 115C are outstanding.
4. The incorporation of a removable undercarriage to allow running take-offs of VATOL aircraft with overload offers a solution which may be worthy of further consideration, particularly if means can be incorporated for improving their STOL capability.
5. To save weight and withstand high aerodynamic heating temperatures Ryan proposed to build the airplane extensively using light gage stainless steel corrugated structure. Such structure was not common practice in the late 1950's and the risk could have been high. However, more recent structural materials developments do offer an acceptable solution to operation under aerodynamic heating conditions.
6. In contrast with Temco, Convair and Lockheed, Ryan used a more advanced approach to vector nozzle flow and thrust for vertical through transition flight. In effect, the nozzles tilted to provide pitch, yaw and roll control; reaction jets at the wing tips were eliminated.
7. Ryan did not present any information on flight safety. Although the preferred designs had two engines, no provision was evident for handling the one-engine-out situation in vertical and transition flight. Consideration must be given to this problem.

# TAKE-OFF AND LANDING RIG

## MODEL 115 DISPERSED-SITE FIGHTER-BOMBER

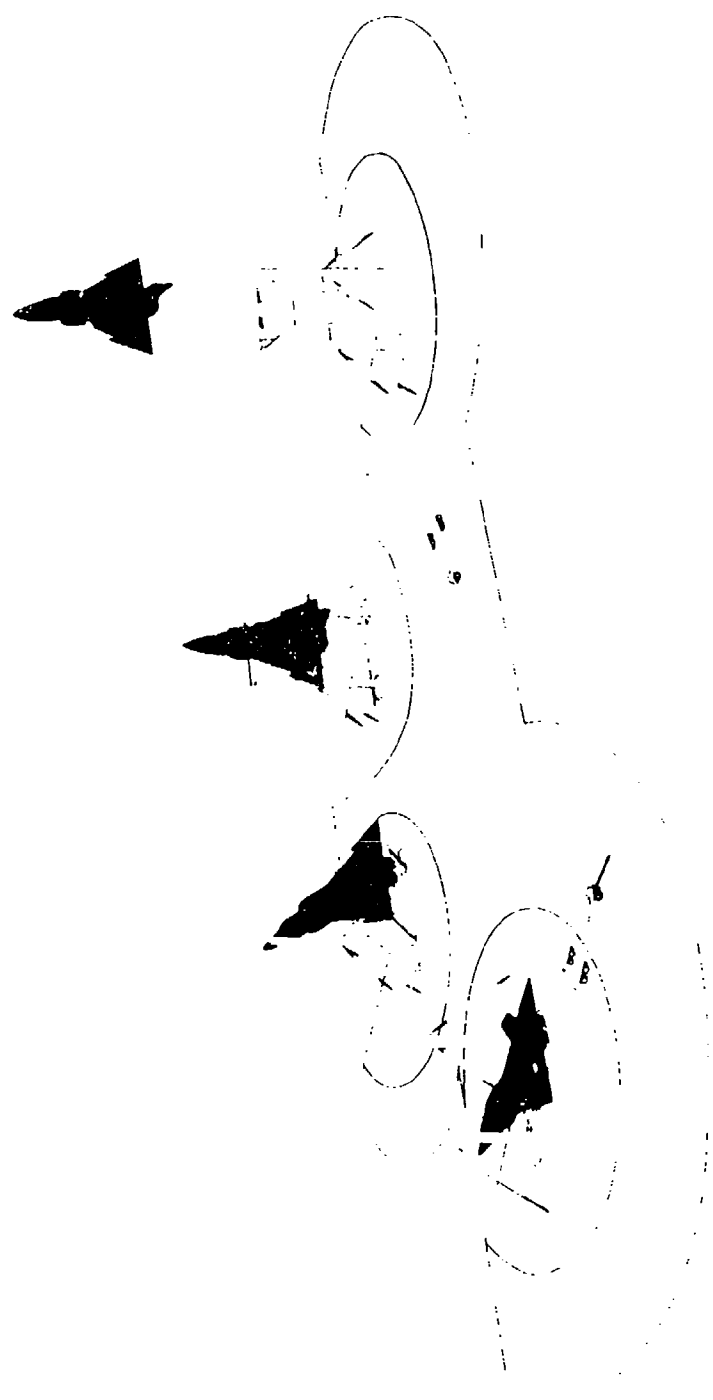

Figure 3.3.5.5.11 Ground Apparatus for the Ryan Model 115  
VATOL Airplane (Courtesy Teledyne Ryan Aeronautical)

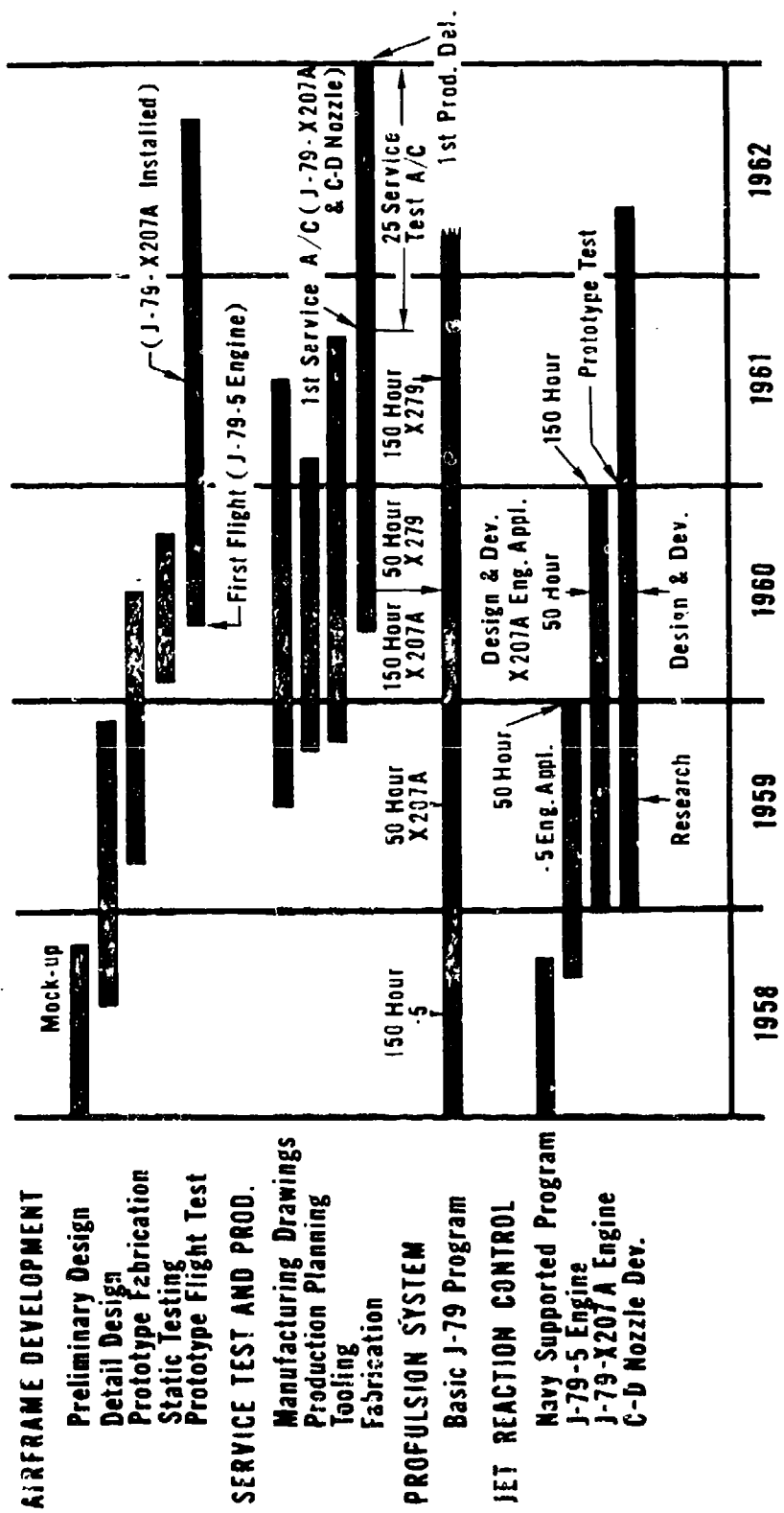

Figure 3.3.5.5.12 Weapon System Development Program for the Ryan Model 115C Dispersed Site Fighter-Bomber (Courtesy Teledyne Ryan Aeronautical)

Subsections 3.3.5.6 through 3.3.5.10 are still in preparation and will be issued as a supplement to this volume.

REFERENCES - SECTION 3.3.5

- 3.3.5.1 Agnew, G.E., "Interim Program Report Advanced Jet Reaction Control Development," Contract No. a(s)-10035 Amend. No. 8, Report No. 10441-2, Ryan Aeronautical Company, Dec. 31, 1956.
- 3.3.5.2 Final Summary Report - Design Study of a VTOL Day-Fighter Aircraft Powered by a Turbofan Engine, Temco Aircraft Corporation Report 39.50.41, 15 June 1954.
- 3.3.5.3 Summary Report, Preliminary Design Study, VTOL Day Fighter Powered by a Turbofan Engine; Convair Report ZP-108; July 30, 1954.
- 3.3.5.4 Study of Stability and Control of VTOL Aircraft, Bureau of Aeronautics TED Project ADC-AE-6101, Engineering Development Department Report No. NADC-ED-5822, 5 June 1959.
- 3.3.5.5 Summary Report, Vertical Take-Off Fighter Design Study, Lockheed California Company Report LR 10707, August 1955.
- 3.3.5.6 Goelzer, H. F., "Final Report, VTO Fighter Design Study," Contract No. AF18(600)-1157, Supplement No. 2, Report No. 8452-1, Ryan Aeronautical Company, July 15, 1955.
- 3.3.5.7 Carroll, P. D. and Forbush, J. M., "Stability and Control Report, VTO High Altitude Visual Fighter, Ryan Model 112," Report No. 11254-1, Ryan Aeronautical Company, Sept. 30, 1956.
- 3.3.5.8 Ryan Aeronautical Company, "Ryan Dispersed Site Fighter Bomber Study," Report No. 11518-2, Nov. 30, 1956.
- 3.3.5.9 Ryan Aeronautical Company, "Airplane Design Summary Report, Dispersed Site Fighter Bomber, Ryan Model 115," Report No. 11518-3, Nov. 26, 1956.
- 3.3.5.10 Ryan Aeronautical Company, "Model 115C, VTOL Fighter-Bomber," Report No. 11505-2, Dec. 9, 1957. (This report is the collection of charts used in briefing U.S. Air Force organizations.)
- 3.3.5.11 Ryan Aeronautical Company, "Development Plan, Dispersed Site Fighter Bomber Study, Ryan Model 115," Report No. 11518-4, Nov. 28, 1956.
- 3.3.5.12 Solarski, Andrew H., "Survey and Study of VTOL-STOL Stability and Control Characteristics," WADC Technical Report 59-357, Wright Air Development Center, Aug. 1959.