

MICROCOPY RESOLUTION TEST CHART  
NATIONAL BUREAU OF STANDARDS 1963-A

2

AD-A177 836



AFWAL-TR-86-2050

EVALUATION AND ANALYSIS OF  
GAS TURBINE INTERNAL FLOW  
RESTRICTORS

Glenn F. Holle

Allison Gas Turbine Division  
General Motors Corporation  
P.O. Box 420  
Indianapolis, Indiana 46206-0420

August 1986

Final Report for period August 1985 - April 1986

DTIC FILE COPY

APPROVED FOR PUBLIC RELEASE; DISTRIBUTION UNLIMITED.

AERO PROPULSION LABORATORY  
AIR FORCE WRIGHT AERONAUTICAL LABORATORIES  
AIR FORCE SYSTEMS COMMAND  
WRIGHT-PATTERSON AIR FORCE BASE, OHIO 45433-6563

DTIC  
ELECTE  
MAR 06 1987  
S E D

87 3 6 013

NOTICE

When Government drawings, specifications, or other data are used for any purpose other than in connection with a definitely related Government procurement operation, the United States Government thereby incurs no responsibility nor any obligation whatsoever; and the fact that the government may have formulated, furnished, or in any way supplied the said drawings, specifications, or other data, is not to be regarded by implication or otherwise as in any manner licensing the holder or any other person or corporation, or conveying any rights or permission to manufacture use, or sell any patented invention that may in any way be related thereto.

This report has been reviewed by the Office of Public Affairs (ASD/PA) and is releasable to the National Technical Information Service (NTIS). At NTIS, it will be available to the general public, including foreign nations.

This technical report has been reviewed and is approved for publication.

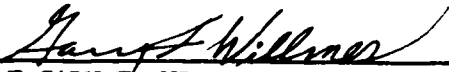

2LT GARY F. WILLMES  
PROJECT ENGINEER

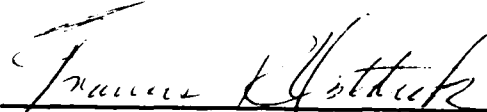

FRANCIS R. OSTDIEK, Chief, Technology  
Branch

FOR THE COMMANDER



MICHAEL E. STEFKOVICH, Major, USAF  
Deputy Director  
Turbine Engine Division  
Aero Propulsion Laboratory

If your address has changed, if you wish to be removed from our mailing list, or if the addressee is no longer employed by your organization please notify AFWAL/POTX, W-PAFB, OH 45433 to help us maintain a current mailing list.

Copies of this report should not be returned unless return is required by security considerations, contractual obligations, or notice on a specific document.

Unclassified

ADA177836

SECURITY CLASSIFICATION OF THIS PAGE

REPORT DOCUMENTATION PAGE

|  |  |  |  |
|--|--|--|--|
| 1a. REPORT SECURITY CLASSIFICATION<br><b>Unclassified</b>  |  | 1b. RESTRICTIVE MARKINGS<br><b>None</b>  |  |
| 2a. SECURITY CLASSIFICATION AUTHORITY  |  | 3. DISTRIBUTION/AVAILABILITY OF REPORT<br><b>Approved for public release; distribution unlimited</b>                                 |  |
| 2b. DECLASSIFICATION/DOWNGRADING SCHEDULE<br><b>N/A</b>  |  | 4. PERFORMING ORGANIZATION REPORT NUMBER(S)  |  |
| 5a. NAME OF PERFORMING ORGANIZATION<br><b>Universal Energy Systems, Inc</b>  |  | 5b. OFFICE SYMBOL (If applicable)  |  |
| 6a. ADDRESS (City, State and ZIP Code)<br><b>4401 Dayton-Xenia Road<br/>Dayton, Ohio 45432</b>   |  | 7a. NAME OF MONITORING ORGANIZATION<br><b>Aero Propulsion Laboratory (AFWAL/POTX)<br/>Air Force Wright Aeronautical Laboratories</b> |  |
| 8a. NAME OF FUNDING/SPONSORING ORGANIZATION<br><b>Aero Propulsion Laboratory</b>   |  | 8b. OFFICE SYMBOL (If applicable)<br><b>AFWAL/POTX</b>   |  |
| 9. PROCUREMENT INSTRUMENT IDENTIFICATION NUMBER<br><b>F33615-85-C-2575</b>   |  | 10. SOURCE OF FUNDING NOS  |  |
| 11. TITLE (Include Security Classification)<br><b>Evaluation and Analysis of Gas Turbine Internal Flow Restrictors</b>   |  | PROGRAM ELEMENT NO<br><b>62203F</b>  | PROJECT NO<br><b>3066</b>  |
| 12. PERSONAL AUTHOR(S)<br><b>James P. Twist, Ph.D.</b>   |  | TASK NO<br><b>12</b>   | WORK UNIT NO<br><b>98</b>  |
| 13a. TYPE OF REPORT<br><b>Final</b>  | 13b. TIME COVERED<br>FROM <b>8/85</b> TO <b>4/86</b> | 14. DATE OF REPORT (Yr., Mo., Day)<br><b>1986 August</b>   |  |
| 15. PAGE COUNT<br><b>147</b>   |  |  |  |
| 16. SUPPLEMENTARY NOTATION   |  |  |  |
| 17. COSATI CODES   |  | 18. SUBJECT TERMS (Continue on reverse if necessary and identify by block number)  |  |
| FIELD  | GROUP  | SUB GR   | <b>Pressure loss factors, coefficients of hydraulic resistance; fluid mechanics of internal flow; air leakage in gas turbines.</b> |
|  |  |  |  |
| 19. ABSTRACT (Continue on reverse if necessary and identify by block number)<br>A comprehensive review of the literature concerning pressure loss calculations for flow through turns and bends, dividing and combining branches, sudden area changes, and orifices was conducted. An evaluation of the proposed analytical procedures was made on the bases of applicability to gas turbine internal flow systems, accuracy of the flow characteristic predictions, and the complexity of the restriction modeling. A standardized loss analysis procedure for each restriction type was selected from the reliable pressure loss models available in the literature. <i>no words</i> |  |  |  |
| 20. DISTRIBUTION/AVAILABILITY OF ABSTRACT<br><b>UNCLASSIFIED/UNLIMITED</b> <input type="checkbox"/> SAME AS RPT <input checked="" type="checkbox"/> DTIC USERS <input type="checkbox"/>  |  | 21. ABSTRACT SECURITY CLASSIFICATION<br><b>Unclassified</b>  |  |
| 22a. NAME OF RESPONSIBLE INDIVIDUAL<br><b>Willmes Gary F., 2nd Lt., USAF</b>   |  | 22b. TELEPHONE NUMBER (Include Area Code)<br><b>(513)255-6720</b>  | 22c. OFFICE SYMBOL<br><b>AFWAL/POTX</b>  |

### FOREWORD

This informal technical report describes technical work accomplished during the Evaluation and Analysis of Gas Turbine Internal Flow Restrictors program conducted under Contract F33615-85-C-2575. The work described was performed during the period 1 August 1985 to 20 April 1986. This contract with Universal Energy Systems, Inc. and Allison Gas Turbine Division of General Motors Corporation was sponsored by the Aeropropulsion Laboratory, United States Air Force, Wright Patterson AFB, Ohio, with Mr. Richard Martin (AFWAL/POTX) as Project Engineer. Technical coordination was provided by 2nd Lt. Gary Willmes. Contract was managed by Dr. James R. Twist.

The technical effort reported was directed by Dr. Philip Snyder and supervised by Mr. Rodney Vogel. Mr. W. David McNulty collected much of the reference material for the research.

Publication of this report does not constitute Air Force approval of the findings or conclusions presented. It is published only for the exchange and stimulation of ideas.

|                    |                                     |
|--------------------|-------------------------------------|
| Accession For      |                                     |
| NTIS GRA&I         | <input checked="" type="checkbox"/> |
| DTIC TAB           | <input checked="" type="checkbox"/> |
| Unannounced        | <input type="checkbox"/>            |
| Justification      |                                     |
| By _____           |                                     |
| Distribution/      |                                     |
| Availability Codes |                                     |
| Dist               | Avail and/or<br>Special             |
| A-1                |                                     |



TABLE OF CONTENTS

|   | <u>Page</u> |
|---|-------------|
| I. INTRODUCTION . . . . .   | 1           |
| II. THEORETICAL ANALYSIS . . . . .                                    | 6           |
| III. TOTAL PRESSURE LOSS COEFFICIENTS FOR TURNS AND BENDS . . . . .   | 12          |
| IV. TOTAL PRESSURE LOSS COEFFICIENTS FOR BRANCHES . . . . .           | 34          |
| V. TOTAL PRESSURE LOSS COEFFICIENTS FOR SUDDEN AREA CHANGES . . . . . | 43          |
| VI. TOTAL PRESSURE LOSS COEFFICIENTS FOR ORIFICES . . . . .           | 56          |
| REFERENCES . . . . .  | 69          |
| BIBLIOGRAPHY . . . . .  | 72          |
| NOMENCLATURE . . . . .  | 122         |
| APPENDIX - SUMMARY OF DERIVATIONS . . . . .                           | A-1         |

LIST OF ILLUSTRATIONS

| <u>Figure</u> |  | <u>Page</u> |
|---------------|--|-------------|
| 1             | GENERAL CONFIGURATION OF CIRCULAR-ARC BENDS . . . . .  | 13          |
| 2             | BOUNDARY BETWEEN LONG AND SHORT CIRCULAR-ARC BENDS<br>REFERENCE (4) . . . . .                              | 15          |
| 3             | TRANSITION REGION FOR FLOW IN LONG CIRCULAR-ARC BENDS<br>REFERENCE (4) . . . . .                           | 16          |
| 4             | EFFECT OF BEND ANGLE ON THE TOTAL PRESSURE LOSS IN<br>SHORT CIRCULAR-ARC BENDS . . . . .                   | 20          |
| 5             | SINGLE SHORT CIRCULAR-ARC BENDS OF $\theta = 90$ DEG . . . . .   | 21          |
| 6             | TOTAL PRESSURE LOSS FACTOR FOR A SINGLE MITRE BEND . . . . .   | 24          |
| 7             | BEND MORPHOLOGY . . . . .  | 25          |
| 8             | TOTAL PRESSURE LOSS CHARACTERISTICS FOR MODIFIED<br>MITRE BENDS OF CONSTANT AREA . . . . .                 | 26          |
| 9             | RESISTANCE COEFFICIENT FOR BENDS OF RECTANGULAR<br>CROSS-SECTION REFERENCE (17) . . . . .                  | 28          |
| 10            | OUTLET TANGENT CORRECTION COEFFICIENT<br>REFERENCES (5) AND (4) . . . . .                                  | 30          |
| 11            | TOTAL PRESSURE LOSS COEFFICIENT FOR 90 DEG CIRCULAR-ARC<br>BENDS OF CHANGING AREA REFERENCE (14) . . . . . | 32          |
| 12            | TOTAL PRESSURE LOSS COEFFICIENT FOR 90 DEG MITRE BENDS OF<br>CHANGING AREA REFERENCE (13) . . . . .        | 33          |
| 13            | COMMON GEOMETRIES FOR JUNCTIONS AND BRANCHES . . . . .   | 35          |
| 14            | COMBINING FLOW-SYMMETRICAL 'Y' JUNCTION REFERENCE (5) . . . .  | 38          |
| 15            | DIVIDING FLOW-SYMMETRICAL 'Y' JUNCTION REFERENCE (5) . . . .   | 39          |
| 16            | 4-WAY DIVIDING JUNCTION REFERENCE (5) . . . . .  | 40          |
| 17            | GENERAL CONFIGURATION OF SUDDEN AREA CHANGES . . . . .   | 44          |
| 18            | SUDDEN EXPANSION OF COMPRESSIBLE TURBULENT FLOW $\gamma = 1.40$ . .  | 48          |
| 19            | RE-ENTRANT INLET IN A FLUID RESERVOIR . . . . .  | 50          |

LIST OF ILLUSTRATIONS (con't)

| <u>Figure</u> |  | <u>Page</u> |
|---------------|--|-------------|
| 20            | EFFECT OF ORIFICE AND INLET ANGULARITY WITH RESPECT TO APPROACH FLOW REFERENCES (8) and (13) . . . . . | 54          |
| 21            | EFFECT OF INLET EDGE CONDITION ON SUDDEN CONTRACTION LOSS REFERENCE (13) . . . . .                     | 55          |
| 22            | SCHEMATIC FOR A TYPICAL ORIFICE RESTRICTION . . . . .  | 56          |
| 23            | LONG HOLE EFFECT REFERENCE (24) . . . . .  | 58          |
| 24            | FLOW THROUGH SHAPR-EDGED ORIFICES COMPARED TO FLOW THROUGH AN IDEAL NOZZLE REFERENCE (29) . . . . .    | 60          |
| 25            | GENERALIZED ORIFICE . . . . .  | 62          |

LIST OF TABLES

| <u>Table</u> |  | <u>Page</u> |
|--------------|--|-------------|
| I            | Classification of Simple Circular-Arc Bends on the Basis of the Loss Mechanisms Dominating the Flow Fields . . . | 14          |
| II           | Turning Loss Factors for the Bend Loss Model by Ito (7) . . .  | 19          |
| III          | Effect of Wall Roughness on Short Circular-Arc Bends . . . .   | 22          |
| IV           | Loss k-factor for Pipe Exits Reference (24) . . . . .  | 49          |
| V            | Characteristics for Incompressible Flow in Duct Entrances and Exits Reference (25) . . . . .                     | 51          |
| VI           | Applicable Range of the Compressible Flow Parameters for Orifice Models Based on Perry (29) . . . . .            | 66          |

## I. INTRODUCTION

The performance of a modern, high temperature gas turbine engine is compromised significantly by associated requirements for component cooling. This cooling is normally accomplished with air bled from the "cold", compressor end of the engine. Consequently, the paths provided to conduct this cooling air require careful design and flow analyses for effective utilization of bleed air resources. Gas path leakage, which may not provide any useful function, occurs between engine components. The combined cooling and leakage flows must be determined and their impact on engine performance evaluated.

The determination of these cooling and leakage flows, called the internal flow analysis, requires the mathematical modeling of a complex network of conduits and restrictions located inside and outside the main gas path from the engine inlet to the final nozzle. The total pressure losses through these conduits and restrictions must be characterized so that the flow capacities can be calculated. Two parameters are used somewhat interchangeably for the flow characteristics or the total pressure loss characteristics of the constituent restrictions. The discharge coefficient,  $C_D$ , is a measure of the flow passing through a restriction relative to the calculated ideal flow at the actual upstream and downstream pressures. The total pressure loss coefficient,  $k$ , is a measure of the energy required to drive the actual flow through the restriction. For example at the same operating conditions, the discharge coefficient and the total pressure loss coefficient based on maximum upstream dynamic pressure are related as

$$C_D = \frac{1}{\sqrt{k - k_e + 1}}$$

for a restriction in the incompressible flow regime.<sup>1</sup>

<sup>1</sup>Nomenclature definition is found on page 122.

The purpose of this program is to formulate flow characteristic models for conduit bends and turns, branches, sudden area changes, and orifices applicable to the restrictions in the internal flow systems of gas turbine engines.

Modeling of flow through the interior cooling and leakage passages of gas turbine engines is an inexact science. These passages are often of unconventional geometries for which experimental data do not exist and for which numerical fluid dynamic analysis is unreliable or impractical. As the result of in situ performance variations due to local conditions of turbulence, approaching flow profile characteristics, proximity of downstream restrictions, heat transfer, and engine-to-engine configuration and dimensional variations, careful rig tests on the actual engine parts will not yield precise flow characteristics for the internal flow system model. These uncontrollable consequences of gas turbine engine design distinguish this flow network analysis from the more exact solutions for conventional piping or ducting systems. The accurate modeling of internal flow systems of gas turbine engines now relies on the modification of "reference" restriction characteristics with application-specific empirical factors based on global experience from engine testing. These limitations do not preclude the reasonable preliminary predictions of internal flow system performance for untested engine designs. Fortunately, the internal flow system is typically comprised of many restrictions in series and parallel arrangements. The composite nature of such flow networks generally relegates the flow restriction characteristics to secondary importance with respect to the correct evaluation of flow areas.

An exhaustive literature search indicated that the  $k$ -factor is the parameter of choice for general restriction geometries. However, the definition of the  $k$ -factor does not enjoy the same consensus. The flow models presented in this report are based upon total pressure loss  $k$ -factors which are referenced to flow conditions calculated at the minimum cross-sectional area at the upstream end of the restriction. The rationale for this selection is discussed in the theoretical analysis section.

The important objectives of k-factor modeling are:

- 1) Prediction of realistic trends and boundary values<sup>2</sup> at approximately correct levels of k-factor for the component geometry at local average flow conditions.
- 2) Relatively simple (usable) formulation of the primary geometric and fluid dynamic parameters into a correlation representative of a broad range of configurations and flow environments.

Such k-factor models allow realistic comparisons for the evaluation of design changes and environment modifications. Prediction of absolute performance levels will usually require an experienced adjustment of the appropriate k-factors to match experimental results.

Often internal flow system models for new engine designs are synthesized initially with k-factors for a static orifice,  $k = 2.7$ , and for an isentropic nozzle,  $k = 1.0$ , in conjunction with exact calculations of the controlling passage areas. These models can be surprisingly accurate when carefully formulated by an experienced flow analyst. The preliminary internal flow model is refined using component k-factors appropriate to the engine design details. Later, when engine performance testing yields measured pressures and temperatures for the internal cavities and passages, the k-factors for the controlling restrictions can be modified to simulate the in situ pressure changes.

Assessing the validity and accuracy of k-factor models for even basic restriction geometries is difficult or impossible without extensive experimental support. Generalized k-factor models are nonexistent for the

<sup>2</sup> These "boundary values" could also be termed limiting or extremum values. As an example, the flow losses for bends of increasing radius ratio,  $r/a$  or decreasing bend angle,  $\theta$ , should approach the wall friction loss for a straight duct of equal bend length and the same cross-sectional geometry as a lower limit.

broader range of restriction geometries necessary for gas turbine internal flow analysis. When the effects of unconventional installations and fluid flow environments are considered, the ability to precisely predict restriction flow characteristics is presently unattainable. However, the purpose of this study is to develop approximate k-factor models for generic bends and turns, branches, sudden area changes, and orifices common to gas turbine secondary flowpaths. These algorithms will produce representative trends and boundary values for the identifiable variables of the geometry and the flow processes.

Open literature contains many performance models for the basic restrictions. Some of these empirical models were derived from poorly controlled or incompletely formulated experiments. Consequently, some of the available k-factor models are limited to unspecified ranges of influential geometric and/or flow parameters. A few k-factor models even produce physically inconsistent performance predictions in particular operating regimes. A small sample of these exceeding limited k-factor predictions are derived from oversimplified analytical models of the flow phenomena.

Sometimes recognized expert opinions exist about the reliability of certain restriction models. Beyond this the only viable procedure for selecting among the potpourri of k-factor models must rely upon comparisons of performance predictions at selected conditions for several of the more comprehensive models and upon evaluation of their boundary values where possible. The development of the k-factor models, or perhaps more correctly the synthesis of the k-factor models, for application to the analysis of internal flow systems in gas turbine engines will be accomplished with such a procedure. One or more sources will be utilized to produce a consistent algorithm of acceptable accuracy that will predict realistic performance trends for variations in component geometry and flow conditions.

The k-factor models sought in this study will be formulated with influence coefficients to correct the "reference" performance predicted for a basic geometry and flow environment, e.g.,

$$k^* = f(x, y, z, Re)$$

for the effects of non-standard geometry or unusual flow conditions,

$$k = C_i C_f C_M k^*$$

Basic flow environments are generally for the isolated component in the incompressible regime. This implies fully developed entrance flow and the effect of complete downstream pressure recovery. The influence coefficients for variations from the basic geometry or standard incompressible flow characteristics will be developed from available data sources. It is worth noting that the k-factors referenced to the dynamic pressure remain relatively constant for many restriction components over a wide range of flow conditions. Therefore, when information does not exist to permit the extension of a model to a broad spectrum of operating environments, the application of the incompressible characteristics to high velocity flows still may be warranted.

## II. THEORETICAL ANALYSIS

The analyses of the internal flow systems of gas turbine engines are based on traditional one-dimensional compressible formulas where the parameter gradients and the velocity profiles are approximated by "average" conditions,

$$\bar{V} = \dot{m} / \bar{\rho} A .$$

Then the apparent loss of "average" total pressure, which results from the use of effective velocity to represent velocity profile, is absorbed in the real system total pressure loss (1).<sup>3</sup> The internal flow system is "complex" from the standpoint that most of its duct geometry changes (form drag) tend to overwhelm wall friction (skin drag) as the source of total pressure losses. The proximity of the restrictions in series is such that fully developed laminar or turbulent flow is seldom achieved. This transitional flow environment contributes to the uncertainty of the one-dimensional analysis. However, the basic simplicity of the formulation and the ability to iterate the model coefficients from experience make the approach viable and perhaps preferable.

The calculation for internal flow system performance generates a network of flows, pressures, and temperatures throughout the cooling and leakage paths in the engine. The steady-state solution has an electrical analog where the restriction k-factors are similar to the resistances and the flows (currents) are found by Kirchoff's law. The total pressures are comparable to the node voltages. The most important descriptors for a typical internal flow system model are the accurate values for flow path cross-sectional areas. The flow area is crucial to the determination of flow and is of first order importance in the estimation of the total pressure loss across restrictions. The basis for defining the k-factor models and the application of these models to the duct geometries which are encountered in gas turbine internal flow systems are discussed.

<sup>3</sup> Bracketed numbers refer to References, page 69..

Selection of the Generalizing Parameter for k-factor

Conventional usage employs the dynamic pressure,

$$q = \rho V^2 / 2 ,$$

as the reference parameter for generalizing internal as well as external drag and pressure loss coefficients for incompressible flows. However, when compressibility effects become important to high velocity flows of gases, there seems to be no consensus on the reference parameter for drag and pressure loss calculations. External aerodynamics has retained the dynamic pressure reference on a uniform basis,

$$F_d = C_d (\rho_0 V_0^2 / 2) A_{ref}$$

Internal aerodynamics vacillates between the traditional dynamic pressure,  $q$ , and the impact pressure,  $(P - p)$ ,

$$P_1 - P_2 = k q_{max} \quad \text{or} \quad P_1 - P_2 = k^+ (P - p)_{max}$$

Both parameters are functions of Mach number and  $\gamma$ ,

$$\frac{q}{P} = \frac{\gamma}{2} M^2 \left( 1 + \frac{\gamma - 1}{2} M^2 \right)^{\frac{\gamma}{1 - \gamma}}$$

and

$$\frac{P - p}{P} = 1 - \left( 1 + \frac{\gamma - 1}{2} M^2 \right)^{\frac{\gamma}{1 - \gamma}}$$

Therefore, either is capable of serving as the generalizing parameter for the kinetic energy effects in compressible flow. In fact, the pressure loss coefficient based on reference area,  $A_n$ , for any restriction can be converted between a dynamic pressure basis and an impact pressure basis without loss of accuracy or generality as

$$k_n = \left[ \frac{\left( 1 + \frac{\gamma - 1}{2} M_n^2 \right)^{\frac{\gamma}{1 - \gamma}} - 1}{\frac{\gamma}{2} M_n^2} \right] k_n^+$$

For incompressible flow,

$$k_n = k_n^+$$

since

$$P - p = q$$

Some k-factor data are referred to restriction exit (downstream:  $n = 2$ ) conditions. This k-factor definition requires an additional iteration to establish the total pressure loss across each restriction. For a given flowrate, total temperature, and duct area, a downstream total pressure must be assumed,

$$\frac{\dot{m} \sqrt{T}}{P_2 A_2} \rightarrow M_2 \rightarrow \left( \frac{q}{P} \right)_2$$

When

$$P_2 = P_1 - k_2 q_2 = P_2 \text{ assumed}$$

the solution has been found. This complication is avoided by using a direct serial solution involving the maximum dynamic pressure at the restriction entrance (upstream:  $n = 1$ ) as the reference parameter. The upstream and downstream k-factors for a specific restriction are related implicitly by

$$k_1 = \frac{\left( \frac{q}{P} \right)_2}{\left( \frac{q}{P} \right)_1} \left[ \frac{k_2}{1 + k_2 \left( \frac{q}{P} \right)_2} \right]$$

A certain commonality is exemplified by the conventional use of dynamic pressure as the reference parameter for the surface drag coefficient for the compressible flow over immersed bodies and for the wall friction in conduits (FANNO flow).

Benedict and Carlucci (2) have shown that the application of k-factor values based on inlet conditions,  $k_1$ , to the equivalent length analysis where

$$4 f \frac{l}{HD} = k_1$$

will overestimate the total pressure loss for compressible flow. The k-factor or  $4 f L / D$  in this FANNO type analysis is applied to a continually increasing dynamic pressure due to a uniformly distributed loss mechanism through the "constant area" restriction. Therefore, a smaller k-factor correlates with the total pressure loss at a given inlet flow condition.

Very little reliable data are available on the k-factors for restrictions of conventional geometry operating in the compressible flow regime. Almost no data exist for the more unusual restriction configurations common to gas turbine internal flow systems. The best data are normally found for incompressible flow through typical pipe and duct geometries. Fortunately, the k-factors based on maximum inlet dynamic pressure are relatively insensitive to Mach number for many restrictions (3). The compressibility effects generally become important above Mach 0.3 where the velocities approach or exceed the critical Reynolds number so that the flow is in the fully turbulent regime.

The selection of maximum inlet dynamic pressure as the reference parameter for total pressure loss coefficients has the merit of minimizing coefficient sensitivity to compressibility effects for most loss mechanisms. The dynamic pressure is analogous to the kinetic energy of the fluid stream. The impact pressure includes the latent energy absorbed by the compressibility of the fluid in addition to the kinetic energy. The maximum inlet dynamic pressure was chosen as the reference parameter for generalizing the characteristics of the total pressure loss coefficients for all of the restriction geometries investigated, with the exception of the sudden expansion. The use of the maximum inlet impact pressure to characterize the sudden expansion results in the advantage of a unity loss coefficient for any jet discharging into a large plenum. The selection of dynamic pressure or impact pressure as the generalizing parameter, and the choice of reference area at the inlet or exit of the restriction is arbitrary. However, the k-factor must be applied to the value of the generalizing parameter for which it was derived at the restriction area to which it was referenced to produce correct predictions of total pressure loss.

Solutions with Duct Cross-sections of Untested Configuration

Most pressure loss data available in the public domain are for circular or rectangular duct cross-sections. Some data exist for annular duct geometries, but their restriction configurations are limited primarily to constant area and gradual expansions. However, many unusual duct shapes, and particularly annular ducts, are encountered in the analysis of the internal flow systems of gas turbine engines. Consequently, when the diameter of an equivalent circular cross-section is required for the evaluation of a flow parameter such as Reynolds number or equivalent duct length, the hydraulic diameter is generally employed,

$$HD = \frac{4 A}{P}$$

For a circular duct  $HD = d$  so that

$$A = \frac{\pi}{4} HD^2$$

For an elliptical duct  $HD \approx \frac{2 a b}{\sqrt{2 (a^2 + b^2)}}$  so that

$$A \approx \frac{\pi}{4} HD \sqrt{\frac{a^2 + b^2}{2}}$$

For an annular duct  $HD = D - d$  so that

$$A = \pi \left( \frac{D + d}{2} \right) \frac{HD}{2}$$

For a rectangular duct  $HD = \frac{2 a b}{(a + b)}$  so that

$$A = (a + b) \frac{HD}{2}$$

An analogy between annular and rectangular cross-sections reveals that as  $a/b \rightarrow 0$ , the rectangle becomes similar in geometrical characteristics to an annulus of small hydraulic diameter where

$$\pi \left( \frac{D + d}{2} \right) \rightarrow (a + b)$$

and

$$\lim_{a/b \rightarrow 0} \frac{HD}{D} = \frac{2a}{\frac{a}{b} + 1} = 2a$$

or more simply

$$\pi D = b$$

and  $\frac{1}{2} (D - d) = a$

This artifice permits the evaluation of many annular restrictions from the comparable restriction data for the analogous rectangular duct.

The applications of the theoretical analyses selected for deriving pressure loss algorithms for turns and bends, combining and dividing branches, sudden expansions and contractions of flow area, and orifices will be discussed in the following sections.

### III. TOTAL PRESSURE LOSS COEFFICIENTS FOR TURNS AND BENDS

Bends are among the more difficult internal flow loss geometries to estimate accurately. The duct geometry and condition of the flow exert very strong influences on the total pressure loss due to the generation of complex secondary flows and downstream recovery processes. For example, circular-arc bends of round or square cross-section develop twin counter-rotating helical vortices which tend to stabilize the flow, as shown in Figure 1. If the duct cross-section is unconventional, e.g., triangular, polygonal, etc., the secondary flow can become complicated with more than two vortices. Inversely, turning in a duct with a narrow annular cross-section may not produce any secondary flow. Combining the effects of duct shape and wall roughness with the rate and amount of turning makes the loss analysis for simple, single circular-arc bends very difficult.

The location and flow environment of bends in turbine engine cooling and leakage paths rarely meet the modeling criteria for upstream and downstream tangent lengths or fully developed velocity profiles. The total pressure loss in a bend is very sensitive to the conditions in the entering flow as established by upstream tangent length, wall roughness, and flow disturbances. The length of the downstream tangent and flow blockage is even more important to the pressure loss as the result of the nature of the recovery process in the flow leaving the bend. Bends in gas turbine engine flow systems are routinely in the region of influence of upstream and downstream restrictions, which contributes to the difficulty of predicting total pressure losses. In addition, the flow area through the bends frequently changes in cooling and leakage paths. The consideration of these application variables make the total pressure loss prediction for internal flow system bends uncertain at best.

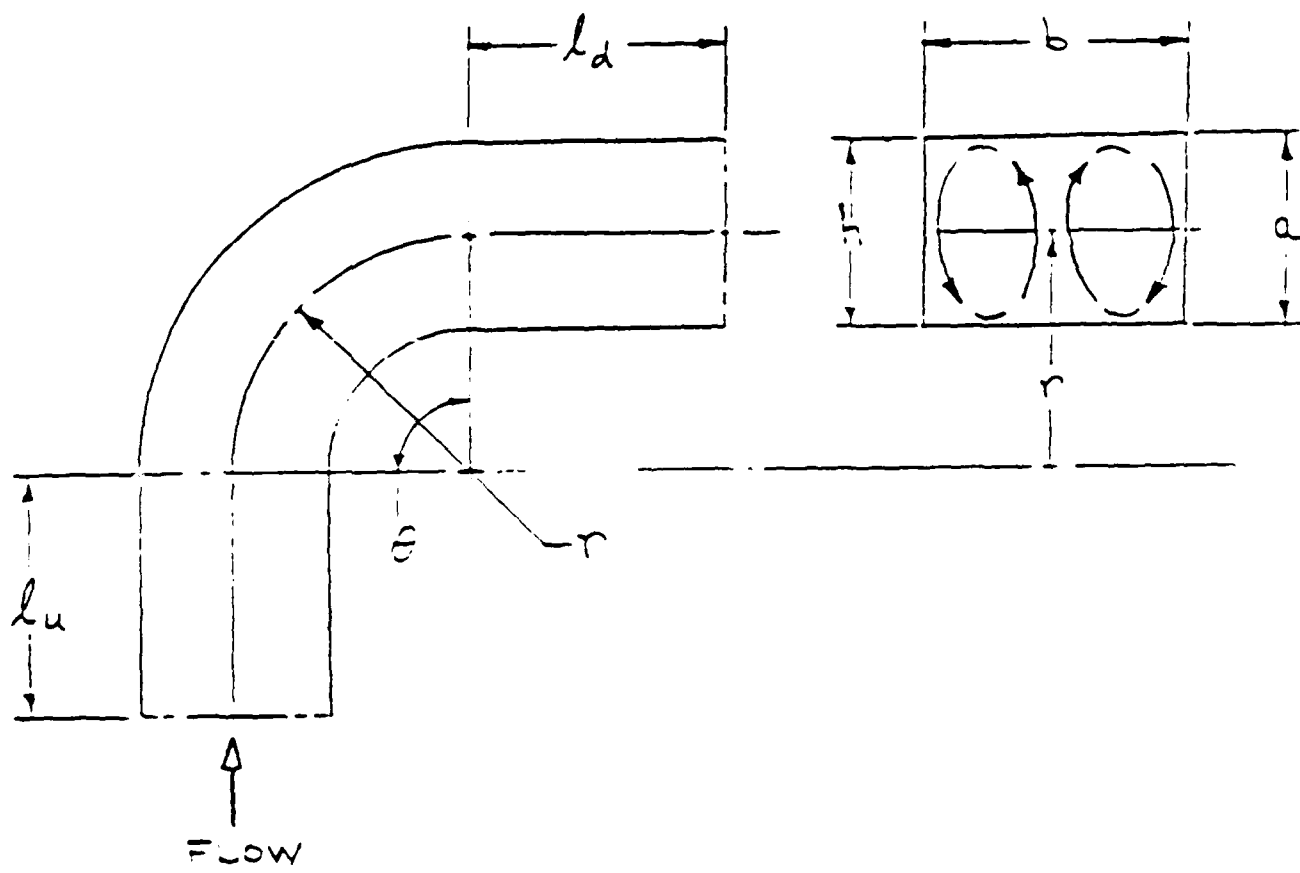

FIGURE 1 GENERAL CONFIGURATION OF CIRCULAR-ARC BENDS

Bends can be classified according to distinct physical characteristics of the flow. The rate of turning has the greatest effect on the flow through bends and is used in Table I to distinguish among the primary types and the physical processes dominating their particular flow fields.

Table I.  
Classification of Simple Circular-Arc Bends on the Basis of the Loss Mechanisms Dominating the Flow Fields.

| <u>Bend Type</u> | <u>r/h</u>    | <u>Predominant Loss Mechanism</u>             |
|------------------|---------------|---|
| Long Bends       | > 14          | Wall friction                                 |
| Short Bends      | < 14<br>> 0.5 | Combined flow separation<br>and wall friction |
| Mitre Bends      | < 0.5         | Flow separation                               |

Reference to Figure 2 shows that turning flow in most gas turbine engine restrictions resides in the short bend (and mitre bend) category. As the result of the generally elevated pressures and temperatures and the high flow velocities in gas turbine engines, the flow in short bends will usually be turbulent,  $R_e > 20000$ , as predicted by Figure 3.

The analysis of internal flow systems in gas turbine engines must attempt to account for the effects of the many variables which influence the total pressure loss in a bend. The effects of the following parameters on bend losses are usually considered where the availability of quantitative data permit:

- Bend Geometry
  - cross-sectional shape
  - turning rate
  - amount of turning
  - area change
  
- Bend Flow Conditions
  - laminar, transitional, or turbulent
  - wall roughness
  - upstream tangent length
  - downstream tangent length

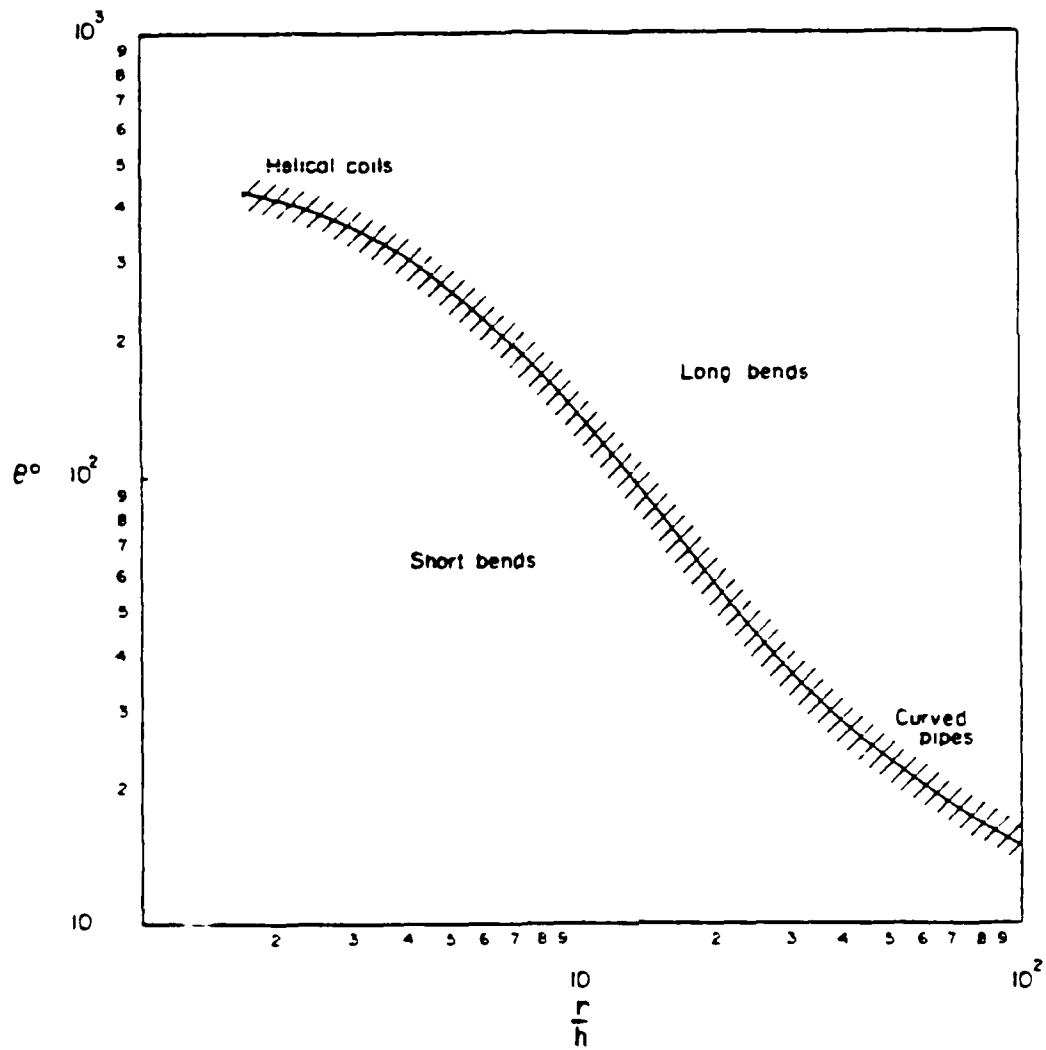

FIGURE 2. BOUNDARY BETWEEN LONG AND SHORT CIRCULAR-ARC BENDS.  
Reference (4)

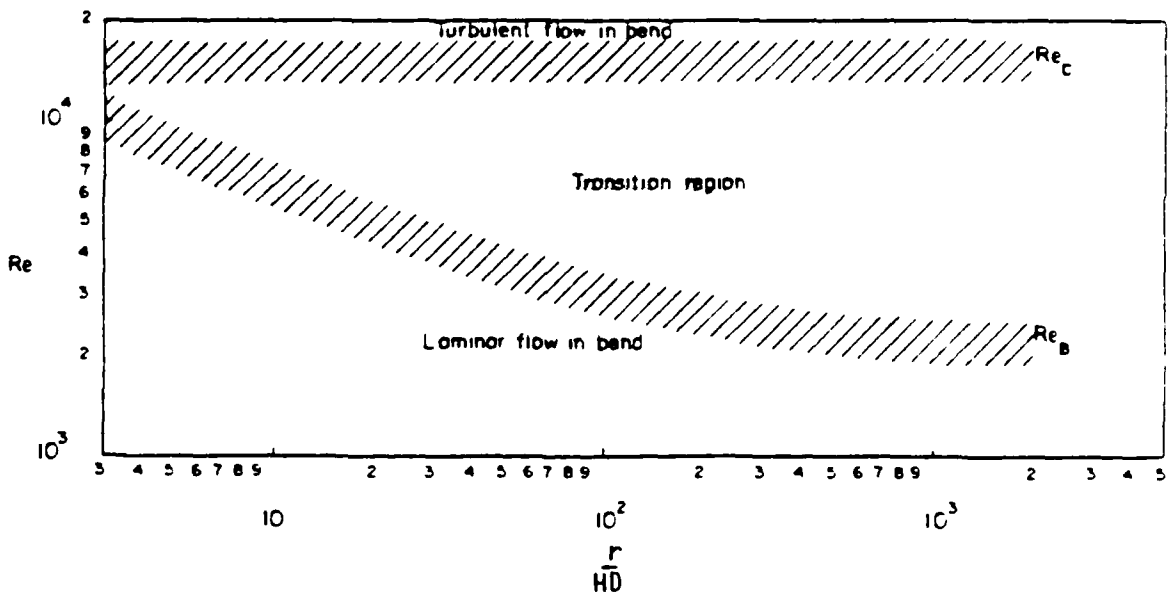

FIGURE 3. TRANSITION REGION FOR FLOW IN LONG CIRCULAR-ARC BENDS.  
Reference (4)

The evaluation of these effects will be discussed as they apply to the single circular-arc bend types. The modeling of compound bends and multiple bends will not be considered. The bibliography contains several references which treat these subjects in varying degrees of analytical depth. Miller (5) and ESDU (6) are recommended sources of reliable performance data. The algorithms presented for bend losses apply to turbulent, incompressible flow. The reliable data references seem to agree upon the application of the incompressible loss factors to compressible flows within the present state-of-the-art. The experimental and analytical data are not yet sufficiently reliable to warrant a distinction at this time.

When a more precise solution is required, and the bend installation and flow quality justify the analytical complexity, reference (4) can be used to model bend K-factors.

#### Basic Circular-Arc Bends

The empirical model for K-factors proposed by Ito (7) is recommended for turbulent flow through bends of circular cross-section in references (1), (4), and (8), among others. The total pressure loss predicted by the Ito model is slightly greater than that predicted in reference (9). However, the wall friction loss is included in the Ito formulas while the plots in reference (9) represent turning loss alone,

$$K_{b(9)} \approx K_{b(7)} - 4f \theta \left( \frac{r}{HD} \right)_b$$

The bend model by Ito is limited to hydraulically smooth walls so that a correction for rough walls is required. Although the algorithm has been validated by test data for a Reynolds number range of  $2 (10^4)$  to  $4 (10^5)$ , the formulas can be extrapolated to a Reynolds number of  $1 (10^6)$  with acceptable accuracy. Bend loss does not change significantly with Reynolds number greater than  $1 (10^6)$ .

$$\text{Long Bends } \operatorname{Re} \left( \frac{h}{r} \right)^2 < 364$$

$$K_b = 0.01746 \alpha f_c \theta \left( \frac{r}{h} \right)$$

Since this equation applies to a minimum  $r/h$  of 7.4, its use in gas turbine internal flow analysis arises infrequently.

The secondary flows present in bends of circular cross-section generate additional losses due to wall friction. These smooth-wall friction losses are correlated for curved turbulent flow at  $\operatorname{Re} \left( \frac{h}{r} \right)^2 < 1200$  by H. Ito (10) as

$$f_c = \frac{0.0205}{\left( \frac{r}{h} \right)^{1/2}} + \frac{0.304}{\left( \operatorname{Re} \right)^{1/4}}$$

The implied region of validity extends to short bends with  $r/h$  as small as 4.1 in addition to the entire long bend envelope.

Short Bends (not including mitre bends)

$$K_b = 0.00431 \alpha \theta \operatorname{Re}^{-0.17} \left( \frac{r}{h} \right)^{0.84}$$

The turning losses for long and short bends are correlated by the  $\alpha$  term as determined from Table II.

A linear interpolation between the defined bend angles produces consistently smooth  $k$ -factor characteristics, as illustrated in Figure 4. The bend loss characteristics generated for 90 deg short bends are plotted in Figure 5.

Idel'chik contends in reference (13) that all turns and bends are essentially independent of the relative roughness,  $\epsilon/D$ , of the wall at Reynolds numbers

Table II.  
Turning Loss Factors for the Bend Loss  
Model by Ito (7).

| $\theta$ -deg               | $r/h$  | $\alpha$  |
|-----------------------------|--------|---|
| 45                          |        | $\alpha = 1 + 5.13 \left(\frac{r}{h}\right)^{-1.47}$    |
| 90                          | < 9.85 | $\alpha = 0.95 + 4.42 \left(\frac{r}{h}\right)^{-1.96}$ |
|                             | > 9.85 | $\alpha = 1.0$  |
| 180                         |        | $\alpha = 1 + 5.06 \left(\frac{r}{h}\right)^{-4.52}$    |
| Proposed for interpolation, |        |   |
| 0                           |        | $\alpha = 1 + 6 \left(\frac{r}{h}\right)^{-1}$          |

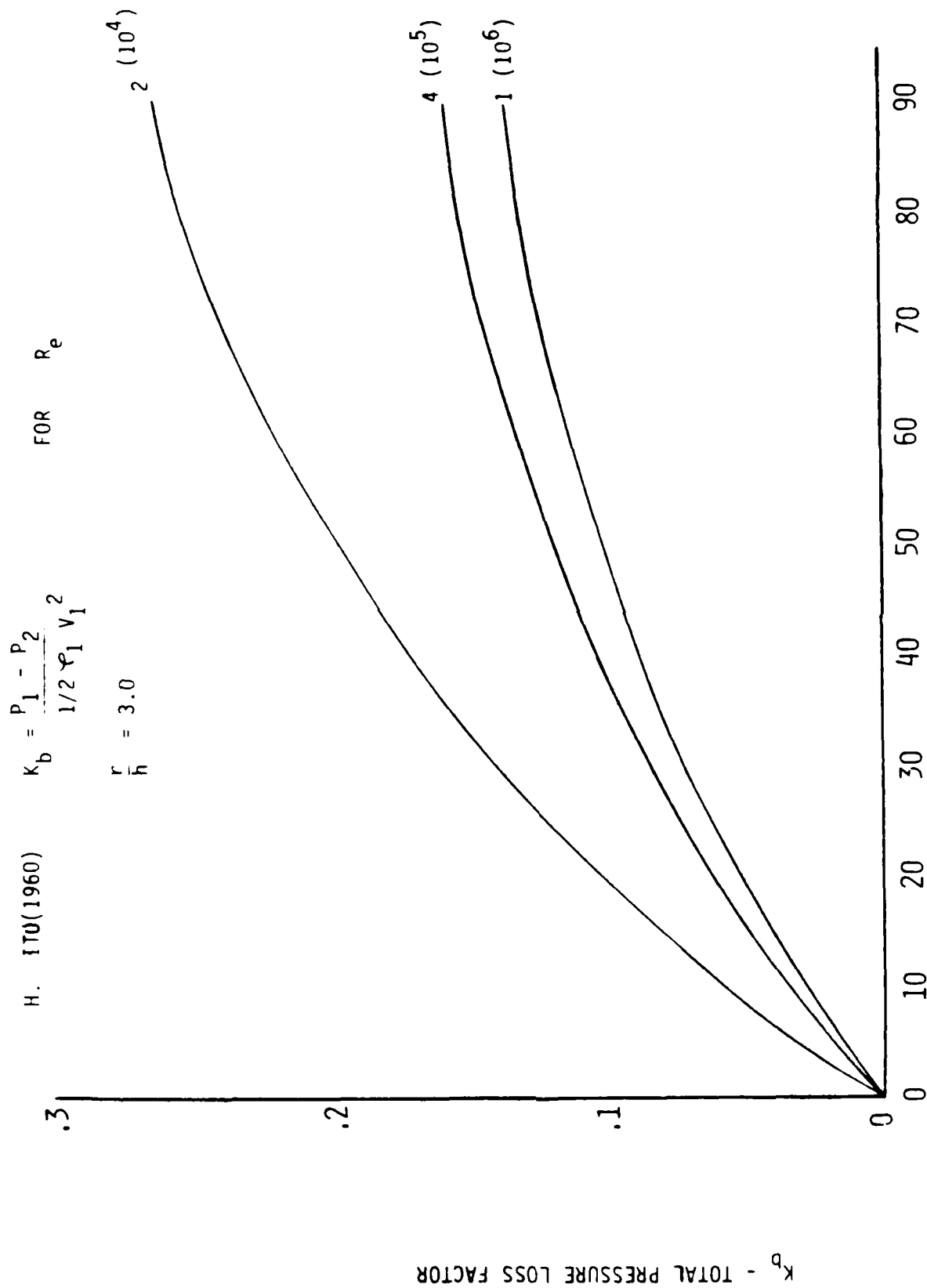

FIGURE 4 EFFECT OF BEND ANGLE ON THE TOTAL PRESSURE LOSS IN SHORT CIRCULAR-ARC BENDS

H. ITO (1960)  $k = \frac{P_1 - P_2}{\frac{1}{2} \rho_1 V_1^2}$  FOR  $\theta = 90^\circ$

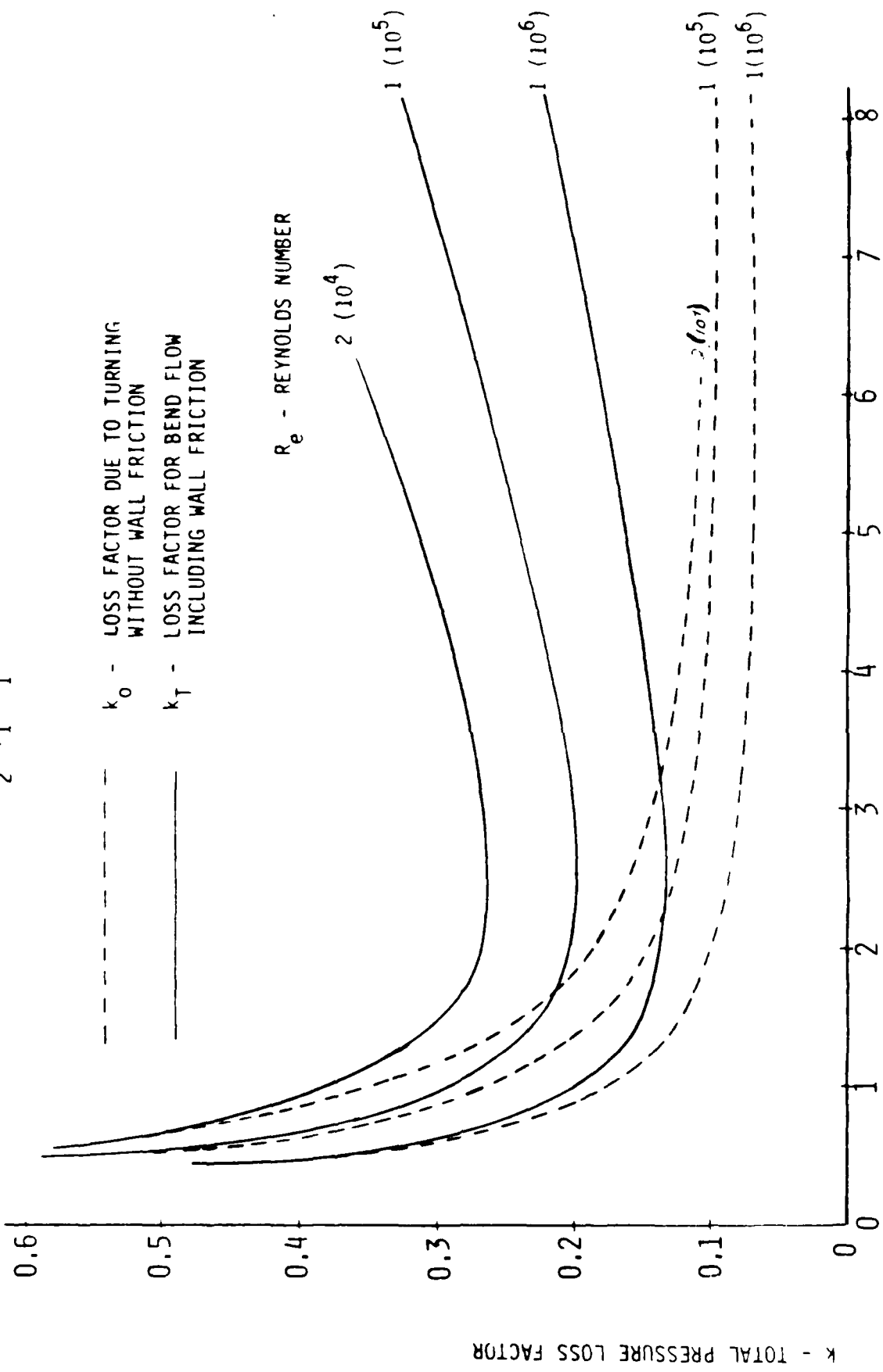

FIGURE 5 SINGLE SHORT CIRCULAR-ARC BENDS OF  
 $\theta = 90$  DEG.

less than  $4 (10^4)$ . The formulation for the k-factor of long bends suggests a direct ratio of friction factors for a wall roughness correction as

$$C_f = \frac{f_{c \text{ rough}}}{f_{c \text{ smooth}}}$$

Unfortunately, reliable data to evaluate or substantiate this hypothesis were not found for friction factors of curved flows. Miller (5) suggests such a wall roughness correction based on straight pipe friction factors applied to all circular-arc bends. Idel'chik (13) restricts this correction factor to circular-arc bends with  $r/HD < 1.5$ . Both Idel'chik (13) and Henry (14) propose a stronger influence of wall roughness at Reynolds numbers above  $2 (10^5)$  and for short bends with  $r/HD > 1.5$ . However, a maximum effect of  $C_f = 2.0$  is proposed by Idel'chik for any combination of wall roughness and Reynolds number. An approximate model combining this general concensus was synthesized for short circular-arc bends as shown in Table III.

Table III.  
Effect of Wall Roughness on Short Circular-Arc Bends.

|   |  |
|---|--|
| <u><math>R_e &lt; 4 (10^4)</math></u>               | $C_f = 1.0$  |
| <u><math>4 (10^4) &lt; R_e &lt; 2 (10^5)</math></u> | $C_{f \text{ max}} = 2.0$  |
| $r/HD < 1.5$  | $C_f = \frac{f_{\text{rough}}}{f_{\text{smooth}}}$                       |
| $r/HD > 1.5$  | $C_f = \left( \frac{f_{\text{rough}}}{f_{\text{smooth}}} \right)^{1.75}$ |
| <u><math>R_e &gt; 2 (10^5)</math></u>               | $C_{f \text{ max}} = 2.0$  |
|   | $C_f = \left( \frac{f_{\text{rough}}}{f_{\text{smooth}}} \right)^{1.75}$ |

### Mitre Bends

The circular-arc bend degenerates into a special case where the concentric inner bend radius goes to zero at  $r/h = 0.5$ . Geometrical interfaces, size limitations, or ease of fabrication produce many bend restrictions with corner points at the inside wall and outside wall,  $r/h = 0$ . These bends and certain variations of similar type are categorized as mitre bends. The unifying characteristic of the flow through mitre bends is the high rate of turning. The separation and turbulent mixing flow processes dominate the total pressure losses in mitre bends so that Reynolds number effects are small to quite low values. Some dispersion is noted from source to source, but an average of data from references (1), (4), (9), and (11), plotted in Figure 6, is a good representation of the group. For most internal flow systems found in gas turbine engines the curve of Figure 6 can be adequately reproduced by the equation proposed by Hager (12) for bend angles greater than 25 degrees,

$$K_b = 2 \left( 1 - \cos \frac{3\theta}{4} \right)$$

As a rule of thumb, between bend angles of 5 degrees and 25 degrees

$$K_b = K_{b(12)} + 0.02$$

can be used.

Figure 7 shows the evolution of the mitre bend and some of the variations which are encountered in practice. Experience with these modified mitre bends has shown that the radius on the inside wall is the most influential geometry factor for reducing the K-factor (total pressure loss).

Corrections applicable to Figure 6 for these geometric variations are provided in Figure 8.

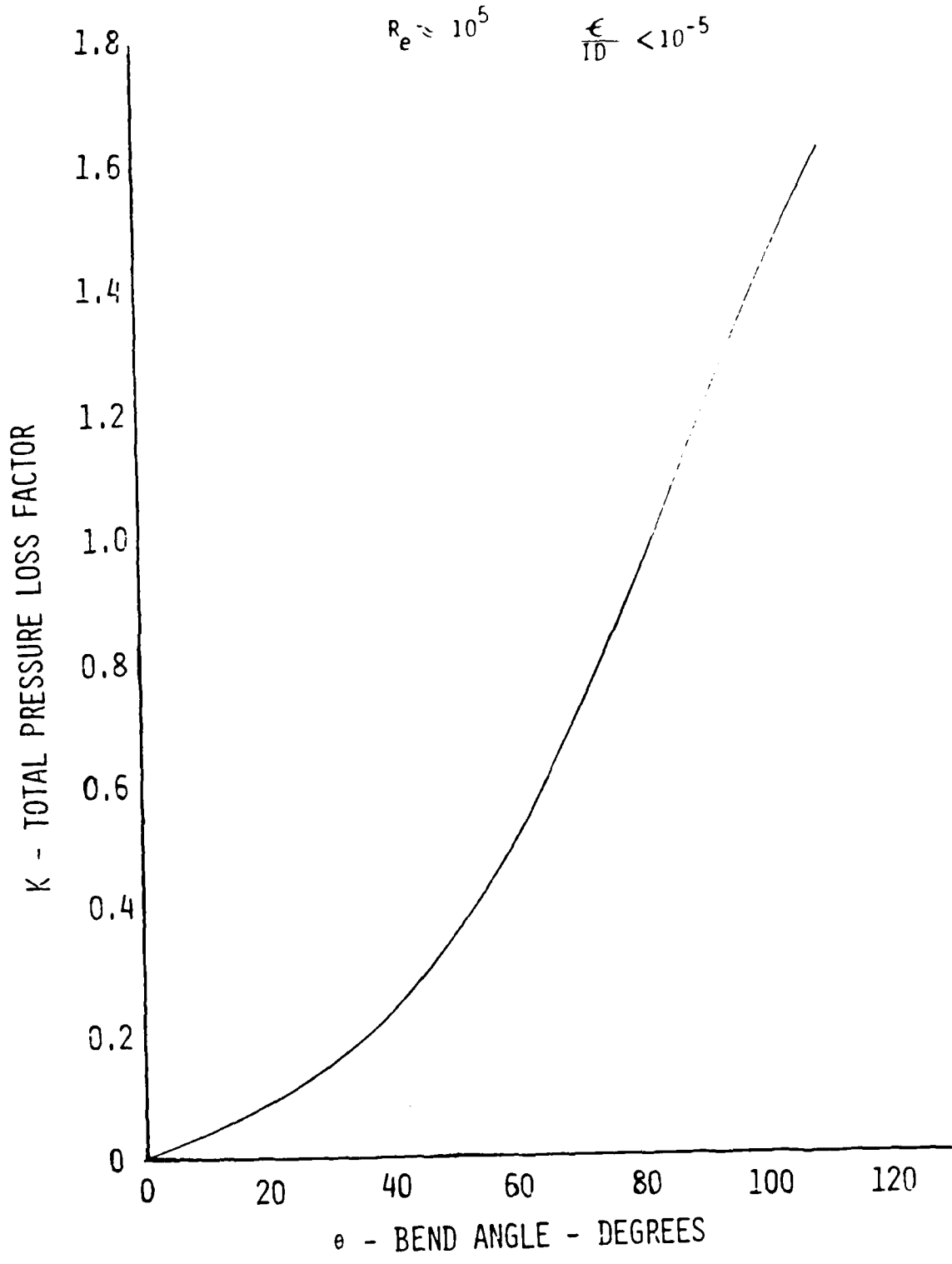

FIGURE 6 TOTAL PRESSURE LOSS FACTOR FOR A SINGLE MITRE BEND

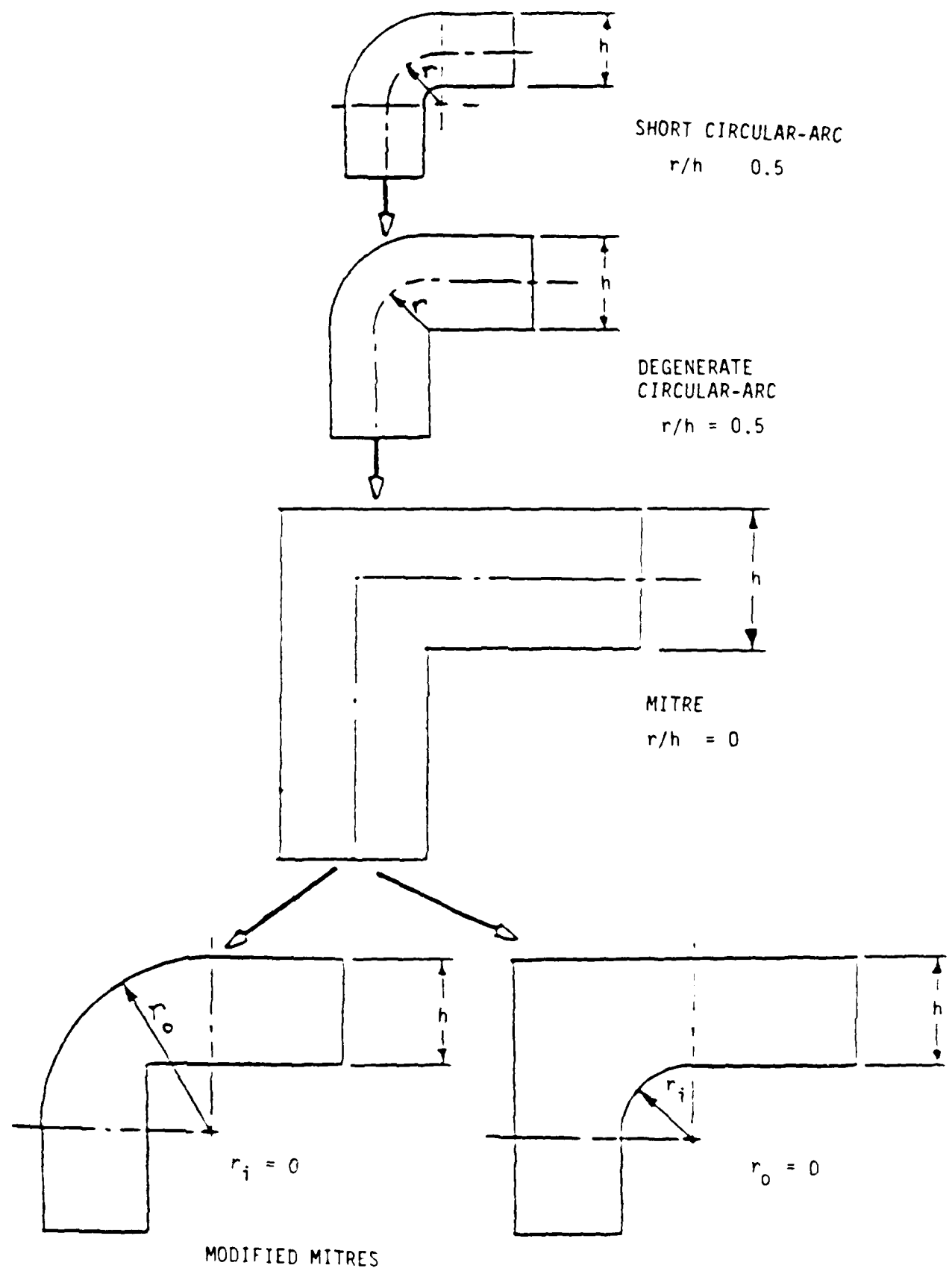

FIGURE 7 BEND MORPHOLOGY

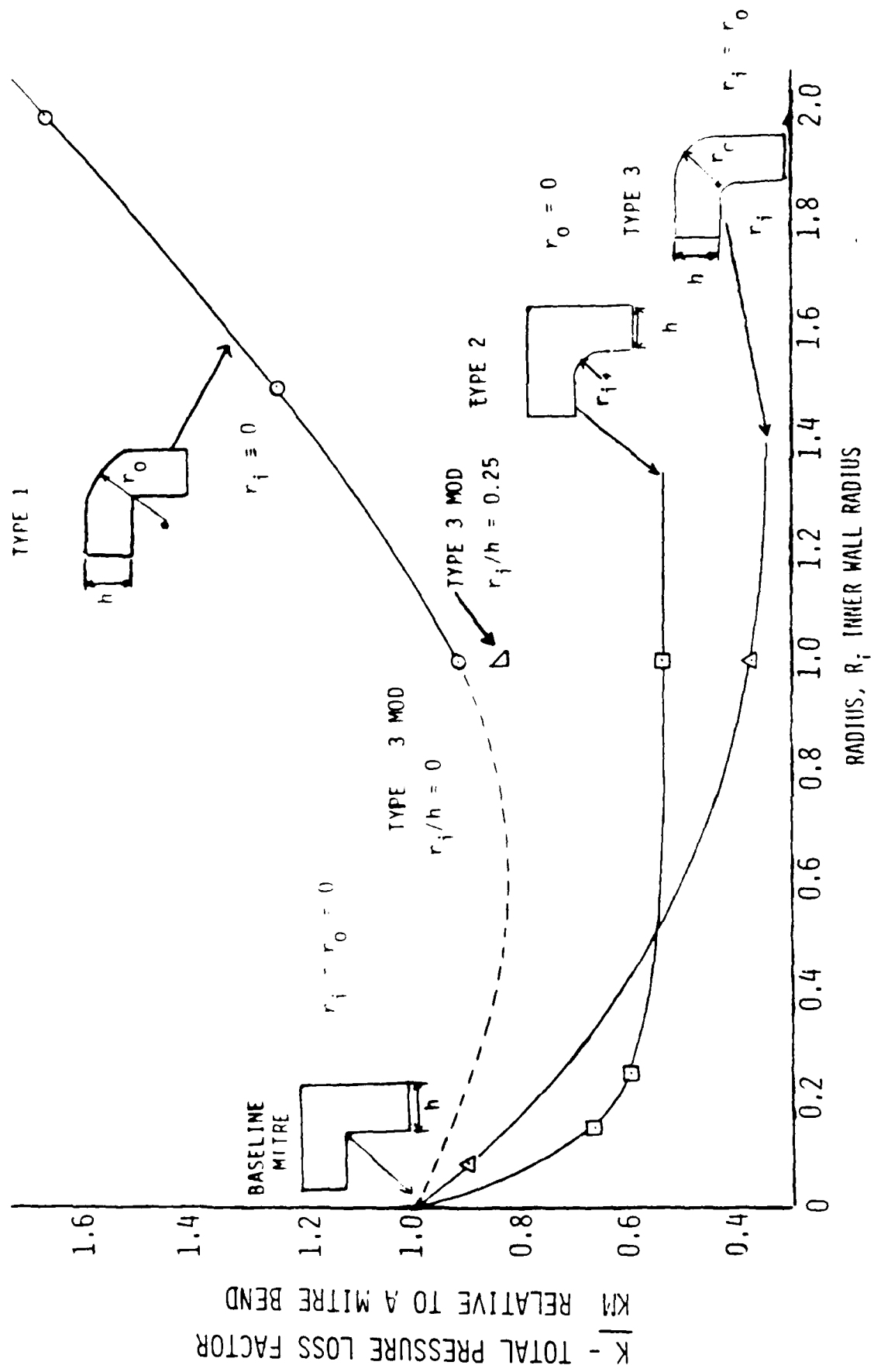

FIGURE 8 TOTAL PRESSURE LOSS CHARACTERISTICS FOR MODIFIED MITRE BENDS OF CONSTANT AREA WITH CONSTANT HEIGHT, , AT INLET AND EXIT

The data of references (4) and (13) indicate that very rough walls can increase the k-factor for mitre bends as much as 50% at Reynolds numbers above  $4(10^4)$ .

$$C_f \approx 1 + 5 (10^3) \left( \frac{\epsilon}{HD} \right)$$

where  $C_{f \text{ max}} \approx 1.5$

Below a Reynolds number of  $4(10^4)$  the effect of roughness or Reynolds number on mitre bend k-factor is negligible.

#### Effects of Other Geometrical Parameters

The basic bend model was derived for ducts of circular cross-section, but testing has shown that the algorithm represents flow through square ducts almost as well. From this point the bend model can be extended to include ducts of elliptical and rectangular cross-section. The bend model was formulated using the geometrical parameters D and h to accommodate this extended scope.

The pressure drop factors for the flow through bends of square and circular cross-section at the same values of r/h (including mitre bends),  $\theta$ , and  $R_e$  are assumed to be negligibly different. Experimental correlations by Ward-Smith (15) and Miller (16) demonstrated this premise for  $1(10^5) < R_e < 13(10^5)$ . Figure 9 is a correlation of rectangular duct performance relative to circular ducts due to Ower and Pankhurst (17). The correction for rectangular bends can be represented by

$$C_g = \frac{1}{2} \left( 1 + \frac{b}{h} \right) \left( \frac{b}{h} \right)^{m-1}$$

$$\frac{k_r}{k_s} = \frac{1}{2} \left(1 + \frac{b}{h}\right) \left(\frac{b}{h}\right)^{m-1}$$

| b/h | m      |
|-----|--------|
| < 1 | 0.2551 |
| > 1 | 0.1386 |

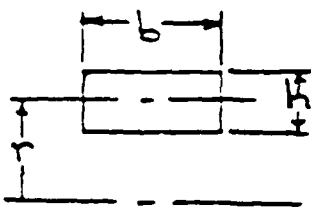
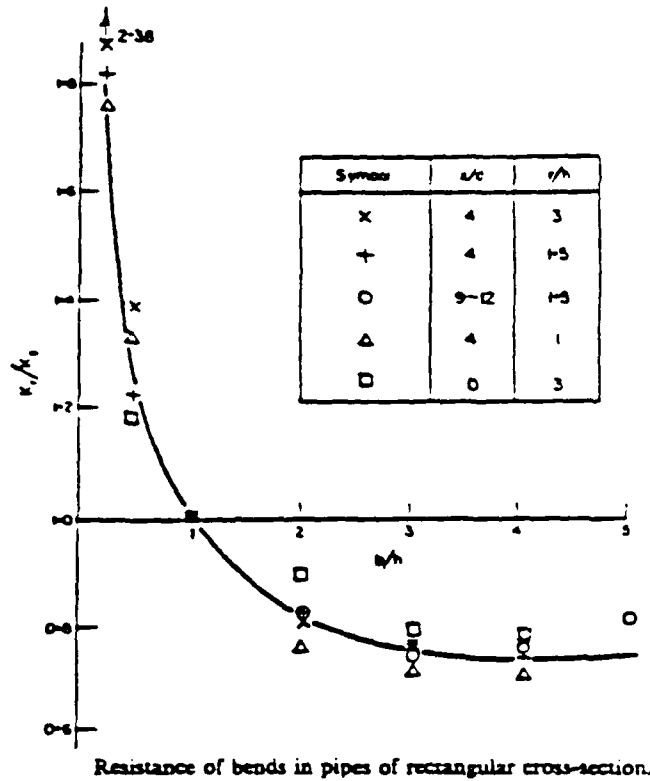

$k_s$  - FACTOR FOR TOTAL PRESSURE LOSS IN A BEND OF SQUARE CROSS-SECTION,  $b = h$ .

$k_r$  = FACTOR FOR TOTAL PRESSURE LOSS IN A BEND OF RECTANGULAR CROSS-SECTION WITH ASPECT RATIO  $b/h$ .

FIGURE 9 RESISTANCE COEFFICIENT FOR BENDS OF RECTANGULAR CROSS-SECTION. REFERENCE (17)

where

$$\begin{array}{rcc}
 b/h & < 1 & > 1 \\
 m & 0.2551 & 0.1386
 \end{array}$$

The performance of elliptical ducts can be estimated from this correlation as a qualitative approximation. If more accurate analysis is required, reference (9) or (14) can be consulted for extensive data on bend performance of elliptical and rectangular ducts.

The basic bend model was derived from test data for fully developed turbulent flow at the inlet to the bend and for a least fifty diameters of downstream tangent length. The downstream tangent generally contributes mixing losses for lengths greater than two diameters. However, as the outlet tangent length diminishes toward zero, the k-factor increases as the initial pressure recovery process in the first two to four diameters of downstream tangent is lost. Miller (5) provides a convenient correction for downstream tangent length, shown in Figure 10. A  $k_b^* = 1.2$  curve based on data in reference (4) has been added ostensibly for corrections to mitre bend k-factors. For ducts of particular rectangular cross-section Miller recommends the following modifications to  $C_\ell$  of Figure 10:

if  $b/h < 0.7$  and  $\ell_d/HD > 1$ ,

$$C_{\ell r} = \frac{1 + C_\ell}{2}$$

If the bend or downstream tangent discharges into a larger duct or plenum, a sudden expansion loss must be added to  $C_\ell$ . Note that neither the bend k-factor nor  $C_\ell$  include the wall friction loss  $(4f \ell / D)_d$  associated with the downstream tangent length.

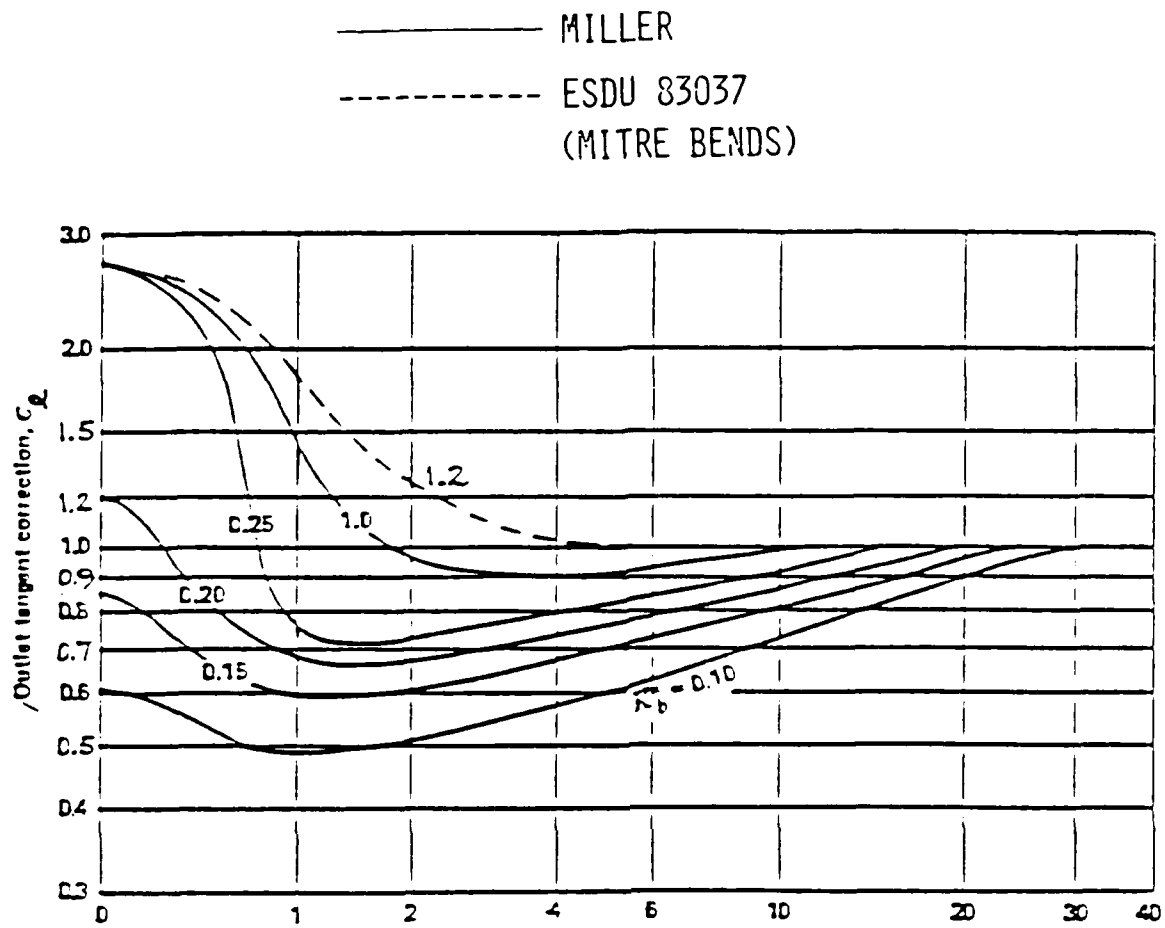

FIGURE 10 OUTLET TANGENT CORRECTION COEFFICIENT.  
REFERENCES (5) AND (4)

The flow in gas turbine internal flow systems is often turned in annular ducts. These annular flow paths and conventional duct paths incorporate turning with area change in many restrictions. The effect of turning with area change in circular arc bends was correlated by Henry (14), Figure 11. Data for k-factors of mitre bends with area change were compiled by Idel'chik (13). A similar presentation of the data is provided in Figure 12. The severe effect of the sharp corner on the inside wall is evident from the inversion experienced by the loss coefficient,  $C_A$ . A sudden expansion alleviates some of the restriction at the mitre corner. The flow turns more gradually with less loss. A contraction at the separation point of the mitre corner restricts the downstream area available for turning. The flow contraction is amplified and the k-factor increases.

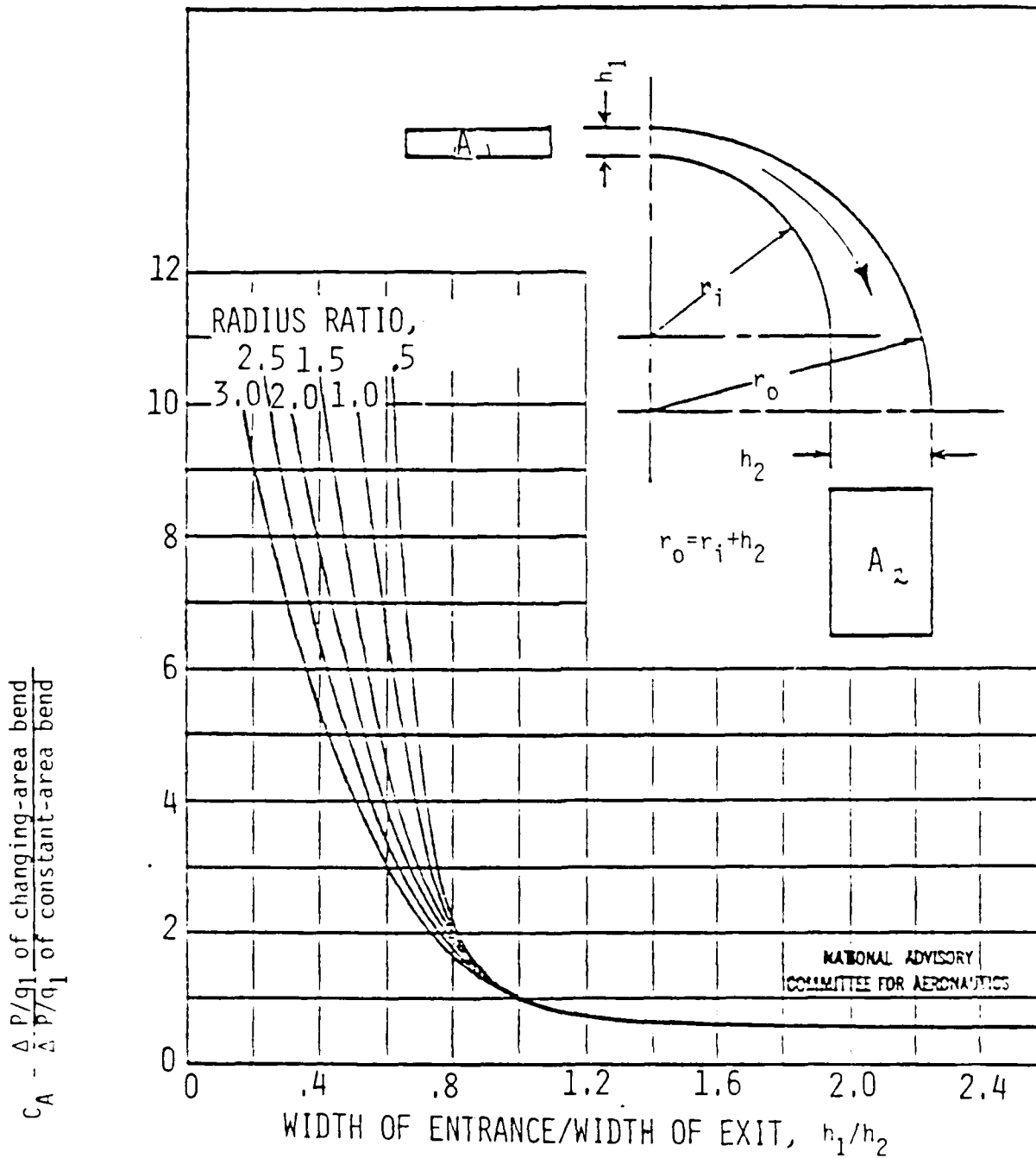

FIGURE 11 TOTAL PRESSURE LOSS COEFFICIENT FOR 90 DEG CIRCULAR-ARC BENDS OF CHANGING AREA. REFERENCE (14)

C<sub>A</sub> TOTAL PRESSURE LOSS COEFFICIENT

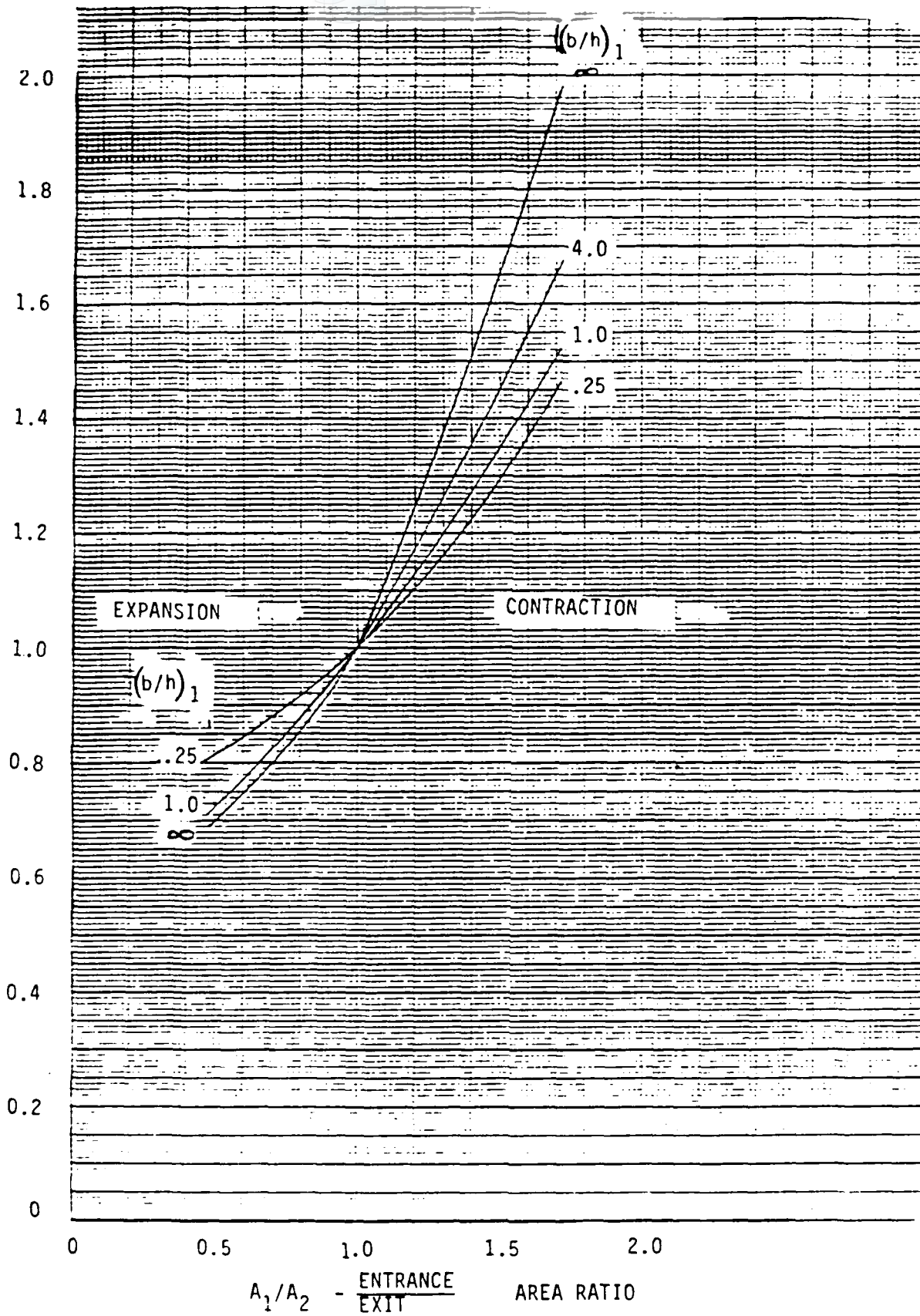

FIGURE 12 TOTAL PRESSURE LOSS COEFFICIENT FOR 90 DEG. MITRE BENDS OF CHANGING AREA. REFERENCE (13)

#### IV. TOTAL PRESSURE LOSS COEFFICIENTS FOR BRANCHES

The steady flows through junctions and branches differ from flows through other restrictions discussed in that mass is increased or decreased within the component. Most restrictions constitute series flow losses where the massflow leaving is the same as the massflow entering. However, internal flow systems contain many flow intersections of parallel restrictions where the local dynamics influence the total pressure loss. The flow model for the intersection should include k-factors which account for the effects of mixing in combining flows and diffusion turbulence in dividing flows. These flow processes are generally a function of the flow split, which requires an iterative solution for the correct k-factor. The flow processes in junctions and branches behave like those in bends in many ways, but the additional effects of mixing flows from different sources or delivering flows to different sinks complicate their physical models. Multitudes of junction and branch geometries exist in engineering practice. Two of the most common geometries, symmetrical and unsymmetrical, are shown in Figure 13.

At a junction or a branch, continuity must be satisfied:

$$m_3 = m_2 + m_1$$

In addition momentum and energy must be conserved:

$$P_3 A_3 + \rho_3 A_3 V_3^2 \approx (P_1 A_1 + \rho_1 A_1 V_1^2) \cos \theta + (P_2 A_2 + \rho_2 A_2 V_2^2) \cos \beta$$

where

$$P_1 A_1 \cos \theta = 0 \quad \text{for the unsymmetrical case}$$

$$m_3 c_{P_3} T_3 = m_1 c_{P_1} T_1 + m_2 c_{P_2} T_2 \quad \text{(adiabatic)}$$

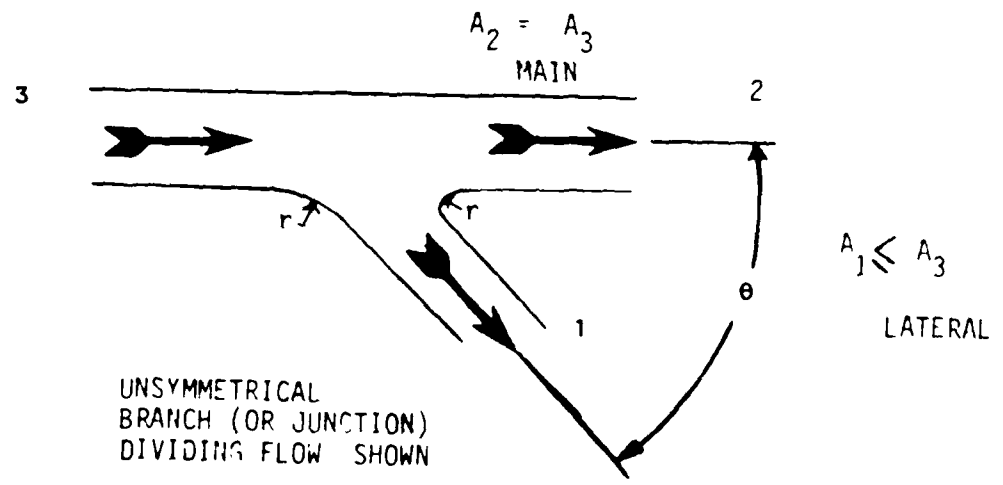
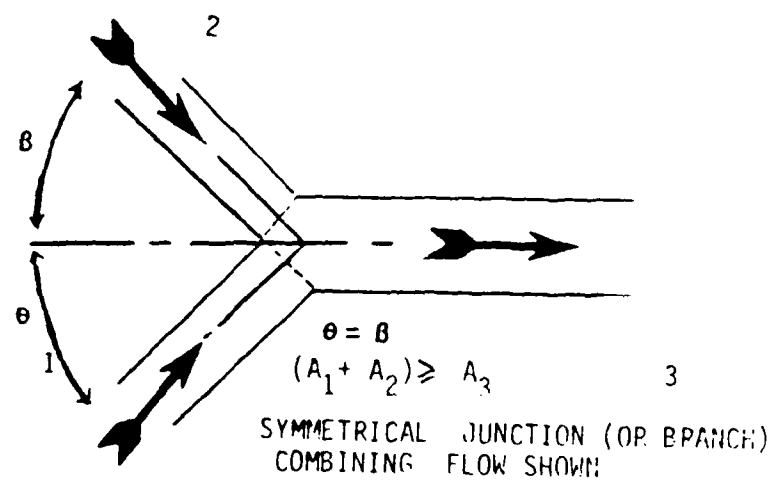

FIGURE 13 COMMON GEOMETRIES FOR JUNCTIONS AND BRANCHES

Vazsonyi (18) attempted the analytical prediction of junction and branch performance on the basis of this physical model utilizing bend flow process analogies. The adaptation of this work for generalized junction and branch k-factors by the SAE (9) was unsuccessful. Although a profusion of pressure loss data exist for a multitude of geometries, the generalization and reduction to usable k-factor parametrics is limited essentially to the basic symmetrical and unsymmetrical varieties. Williamson and Rhone (19), however, do present a survey of special geometries.

The k-factors,  ${}_n k_3$ , have been defined using the dynamic pressure in the limb with the combined flow (leg 3). The k-factor is positive for a total pressure loss or is negative for a total pressure gain. The k-factors presented for junctions and branches do not include the total pressure lost to wall friction. Consequently, the loss model for combining or dividing flows with upstream tangent and downstream tangent at least three hydraulic diameters long should be as follows:

$${}_n \Delta_3 P = {}_n k_3 \left( \frac{1}{2} \rho_3 V_3^2 \right) + 4f_3 \left( \frac{L}{D} \right)_3 \left( \frac{1}{2} \rho_3 V_3^2 \right) + 4f_n \left( \frac{L}{HD} \right)_n \left( \frac{1}{2} \rho_n V_n^2 \right)$$

Occasionally it is desirable to reference the k-factor to another leg (n),

$${}_3 k_n = \left[ \frac{\left( \frac{\dot{m}}{A} \right)_3}{\left( \frac{\dot{m}}{A} \right)_n} \right]^2 \left( \frac{\rho_n}{\rho_3} \right)_n k_3$$

As for bends, experimental results for circular ducts and square ducts show negligible difference (1). Little influence from Reynolds number is evident in turbulent flow. When the flow is not turbulent, the energy contribution is generally minimal due to small dynamic pressure.

Although the following junction and branch models are based on experiments with fluids at constant densities, the results can be applied to compressible flows with reasonable accuracy.

If more analytical precision is required and the restriction geometry and flow environment warrant, reference (20) for combining flow junctions and reference (21) for dividing flow branches can be used for restriction modeling

Symmetrical Junctions and Branches

Symmetrical junctions and branches are often referred to as wyes because of their geometrical configuration. The data of Miller (16) correlate well with that of other investigators and are slightly pessimistic. It is ordinarily good design practice to err on the side of high total pressure loss, so the Miller (5) performance maps in Figure 14 were selected for the total pressure loss associated with combining flows in wyes,

$${}_1k_3 = \frac{P_1 - P_3}{\frac{1}{2} \rho_3 V_3^2}$$

Similarly, the performance maps by Miller (5) in Figure 15 were preferred for the total pressure loss model of dividing flows in wyes,

$${}_1k_3 = \frac{P_3 - P_1}{\frac{1}{2} \rho_3 V_3^2}$$

Another common class of symmetrical junction is the 90° three-way dividing branch or four-way cross. Miller (5) provides k-factor maps, shown in Figure 16, for the perpendicular off-take leg,  ${}_1k_3$ , and for the straight-through leg,  ${}_2k_3$ . The performance is shown for a dividing junction with all legs of equal area and with sharp edges at the intersections.

Unsymmetrical Junctions and Branches

Junctions and branches having two of the limbs colinear are frequently encountered in gas turbine internal flow systems. Restrictions interfacing at 90 deg tees are common. The modeling of manifolds is one of the most important applications for such k-factor data. Fortunately, Gardel (22) has done a comprehensive experimental program to determine the effects of

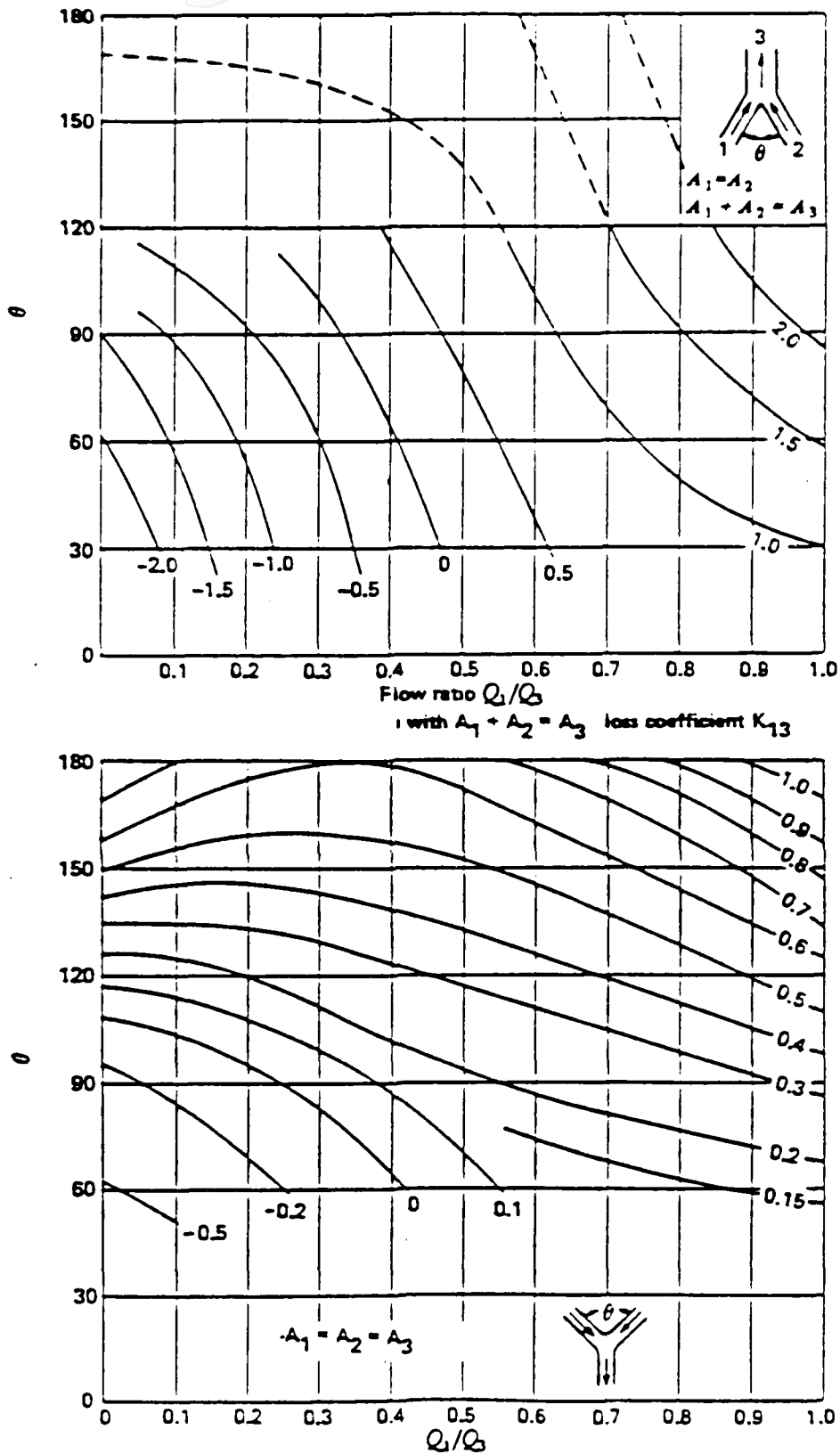

FIGURE 14. COMBINING FLOW—SYMMETRICAL 'Y' JUNCTION.  
Reference (5)

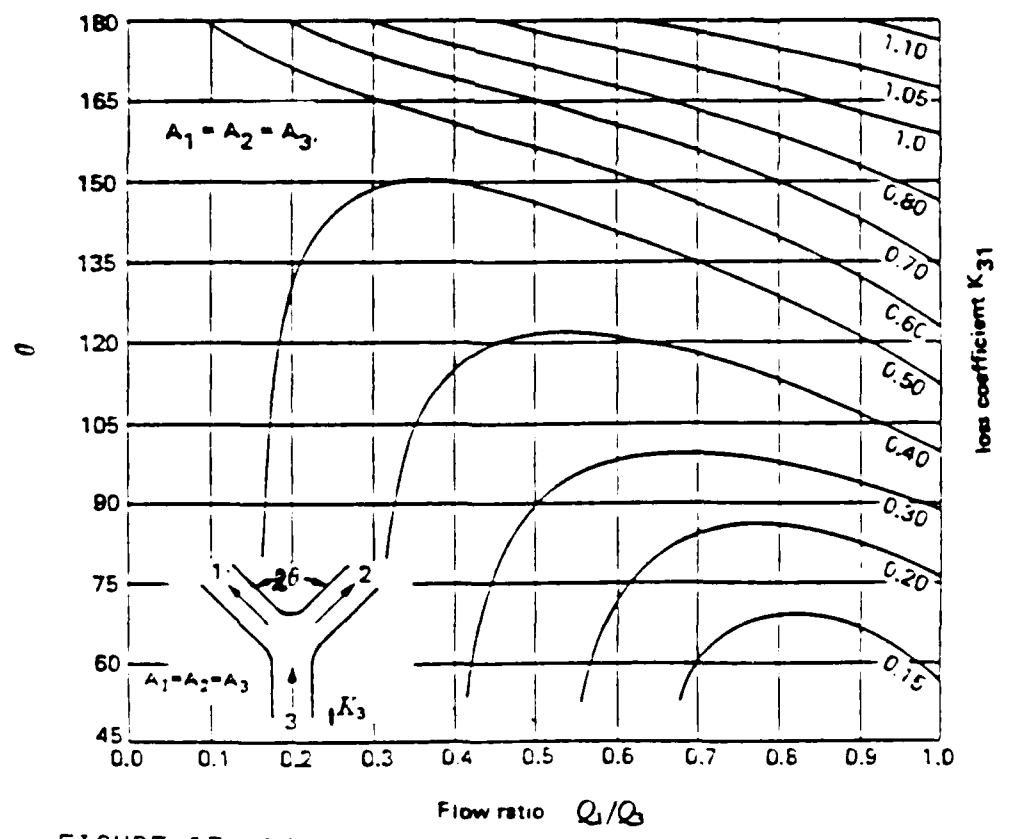
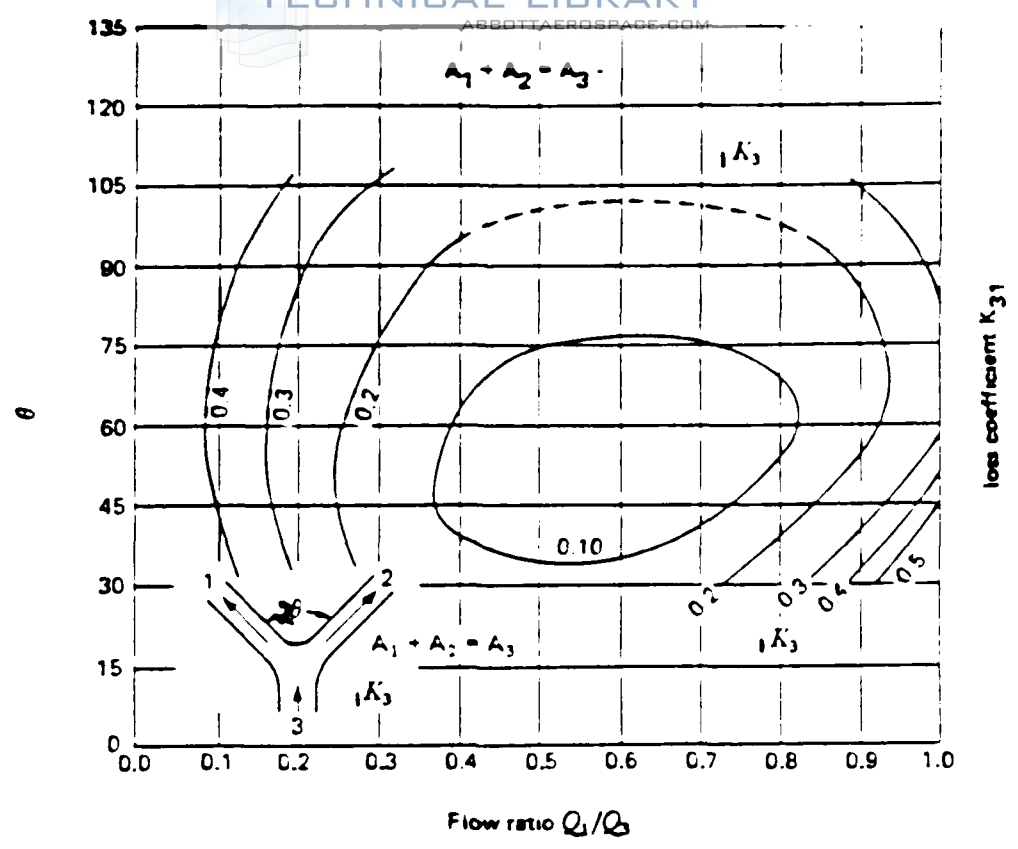
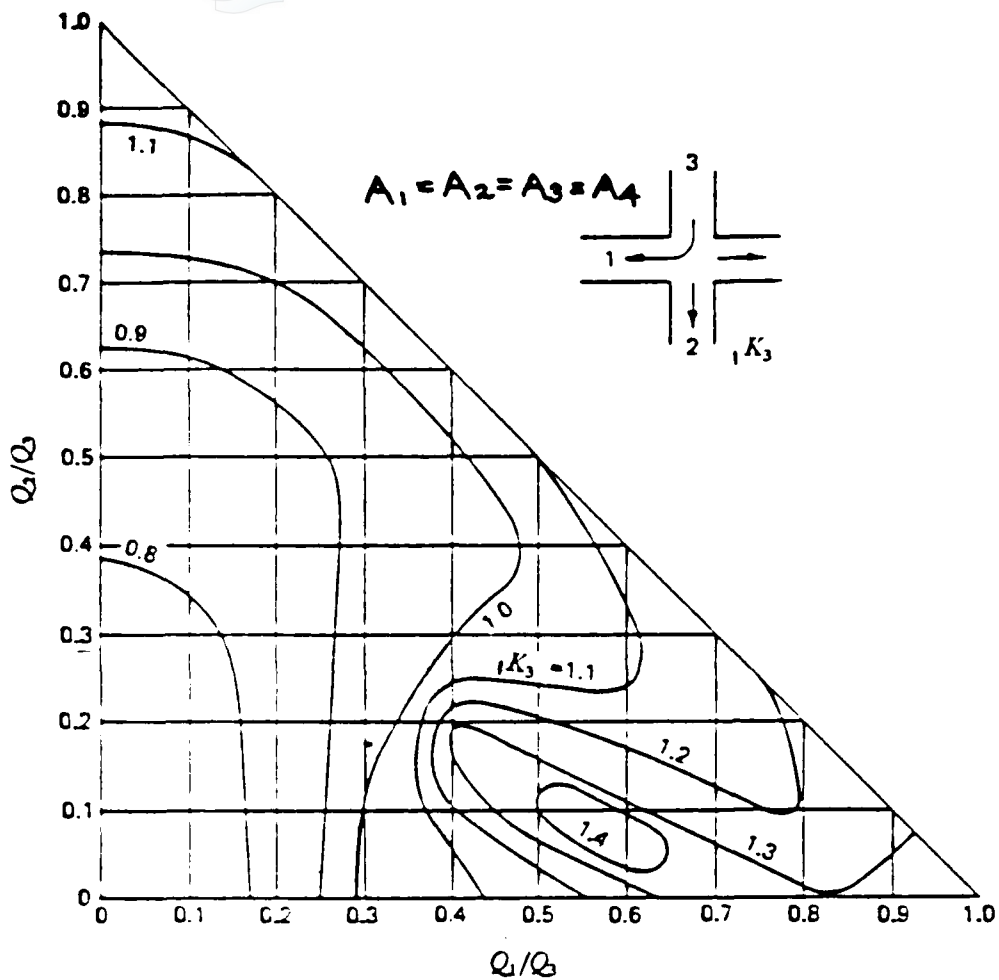
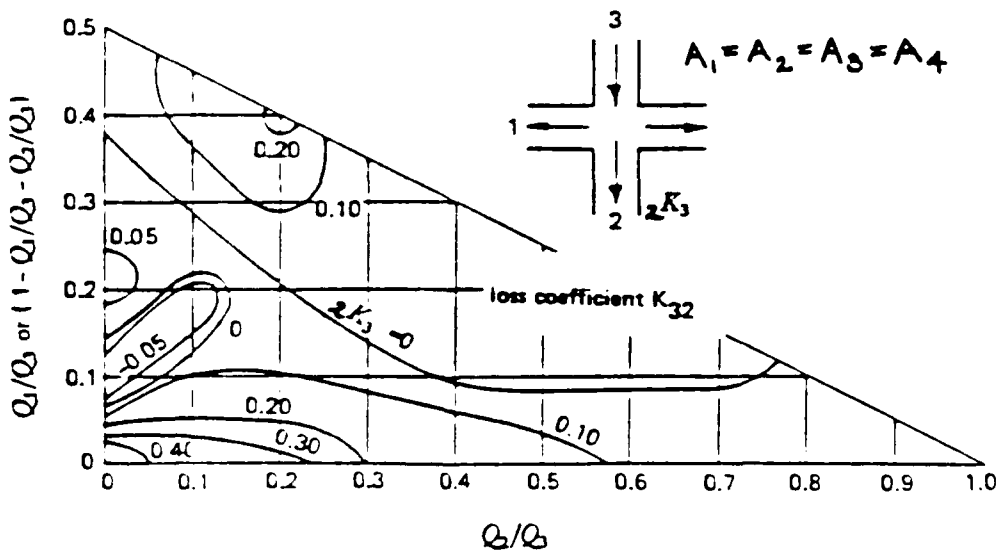

FIGURE 15 DIVIDING FLOW-SYMMETRICAL 'Y' JUNCTION REFERENCE (5)



loss coefficient  $K_{31}$



$Q_1/Q_3$

FIGURE 16 4-WAY DIVIDING JUNCTION. REFERENCE (5)

changing duct sizes, lateral angles, and introducing fillets and radii at the lateral limb. Gardel derived the following empirical equations to represent the performance of unsymmetrical junctions (combining flow):

$$\begin{aligned}
 {}_1k_3 &= -0.92 (1 - q)^2 - q^2 [(1.2 - r^{1/2})(\frac{\cos \theta}{a} - 1) \dots \\
 &\dots + 0.8 (1 - \frac{1}{a^2}) - (\frac{1}{a} - 1) \cos \theta] + (2 - a)(1 - q) q \\
 {}_2k_3 &= 0.03 (1 - q)^2 - q^2 [1 + (1.62 - r^{1/2})(\frac{\cos \theta}{a} - 1) \dots \\
 &\dots - 0.38 (1 - a)] + (2 - a) (1 - q) q
 \end{aligned}$$

where

$${}_1k_3 = \frac{P_1 - P_3}{1/2 \rho_3 V_3^2} \quad \text{and} \quad {}_2k_3 = \frac{P_2 - P_3}{1/2 \rho_3 V_3^2}$$

For unsymmetrical branches (dividing flow):

$$\begin{aligned}
 {}_1k_3 &= 0.95 (1 - q)^2 + q^2 [(1.3 \tan \frac{\theta}{2} - 0.3 + \frac{(0.4 - 0.1a)}{a^2}) \dots \\
 &\dots (1 - 0.9 (\frac{r}{a})^{1/2})] + 0.4 q (1 - q) (\frac{1 + a}{a^2}) \tan \frac{\theta}{2} \\
 {}_2k_3 &= 0.03 (1 - q)^2 + 0.35 q^2 - 0.2 q (1 - q)
 \end{aligned}$$

where

$${}_1k_3 = \frac{P_3 - P_1}{1/2 \rho_3 V_3^2} \quad \text{and} \quad {}_2k_3 = \frac{P_3 - P_2}{1/2 \rho_3 V_3^2}$$

In these equations  $q = \frac{Q_1}{Q_3}$

for a range of lateral angle  $15^\circ < \theta < 165^\circ$

Also  $a = \frac{A_1}{A_3}$  ( $0.625 < a < 1$ )

and  $r = \frac{r}{HD_3}$  ( $0 < r < 0.12$ )

for compressible flows  $q = \frac{m_1}{m_3}$  is preferred.

## V. TOTAL PRESSURE LOSS COEFFICIENTS FOR SUDDEN AREA CHANGES

The most common restrictions encountered in modeling internal flow systems for gas turbine engines are sudden expansions and sudden contractions as illustrated in Figure 17.

The sudden expansion loss is well represented by a one-dimensional analysis. Although the sudden contraction appears to be the geometrical reverse of the sudden expansion, it is not possible to obtain a comparable explicit solution for total pressure loss from a one-dimensional flow model.

### Sudden Expansion

Flow from a duct into a sudden enlargement can be analyzed by conserving mass, momentum, and energy between the discharge plane,  $A_1$ , and the reattachment plane,  $A_2$ . Incompressible turbulent flow is well represented by the Borda-Carnot relation

$$k_{se} = \left(1 - \frac{A_1}{A_2}\right)^2$$

where

$$\Delta P = k_{se} q_1$$

Laminar flow correlates poorly with the one-dimensional equations due to:

- o the large velocity gradients in the profile of the efflux,
- o the important shear stress contribution to reattachment with the possible unsymmetrical flow fields in two-dimensional duct geometries.

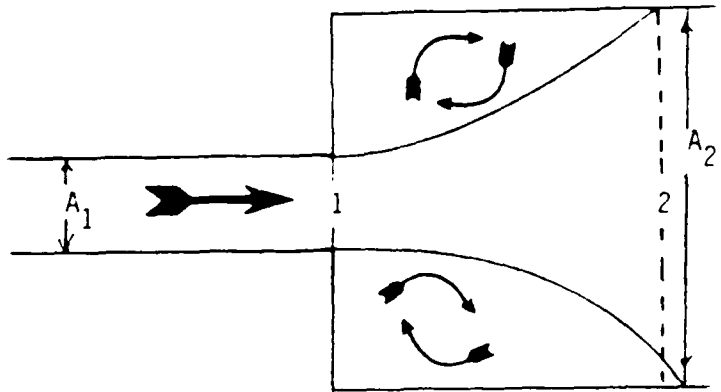

SUDDEN EXPANSION

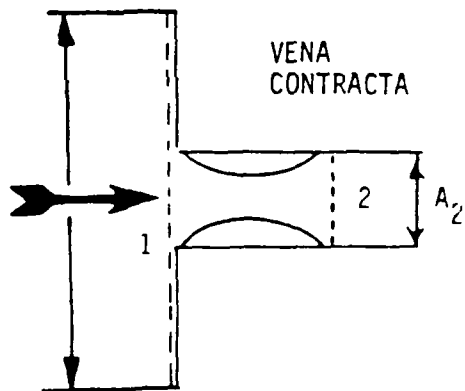

SUDDEN CONTRACTION

FIGURE 17 GENERAL CONFIGURATION OF SUDDEN AREA CHANGES

Adiabatic compressible flow can be modeled similarly as described by Benedict, et. al., (23)

$$\frac{M_2 \left(1 + \frac{\gamma-1}{2} M_2^2\right)^{1/2}}{1 + \gamma M_2^2} = \frac{M_1 \left(1 + \frac{\gamma-1}{2} M_1^2\right)^{1/2}}{1 + \gamma M_1^2 + \left(\frac{p_e}{p_1}\right) \left(\frac{1-\lambda}{\lambda}\right)}$$

where

$p_e$  - static pressure at the face of the step.

When the efflux from duct  $A_1$  is subsonic ( $0 \leq M_1 \leq 1$ ), the flow field in the enlargement is also subsonic ( $0 \leq M_2 \leq 1$ ) and  $p_e/p_1 = 1.0$ .

Ward-Smith (1) suggests using a parameter

$$N = \frac{M}{\left(1 + \frac{\gamma-1}{2} M^2\right)^{1/2}}$$

which simplifies the subsonic equation to the recognizable quadratic form

$$N_2^2 - \left\{ \frac{2}{(\gamma+1)\lambda N_1} \left[ 1 + N_1^2 \left( \gamma\lambda - \frac{\gamma-1}{2} \right) \right] \right\} N_2 + \frac{2}{\gamma+1} = 0$$

Then

$$N_2 = \left(\frac{-b}{2}\right) \pm \sqrt{\left(\frac{-b}{2}\right)^2 - \left(\frac{2}{\gamma+1}\right)}$$

where

$$-\frac{b}{2} = \frac{1 + N_1^2 \left( \gamma\lambda - \frac{\gamma-1}{2} \right)}{(\gamma+1)\lambda N_1}$$

and

$$M_2 = \sqrt{\frac{N_2^2}{1 + \frac{\gamma-1}{2} N_2^2}}$$

The total pressure ratio is determined by the expansion geometry and Mach numbers as

$$\frac{p_2}{p_1} = \lambda \left( \frac{M_1}{M_2} \right) \left[ \frac{1 + \frac{\gamma-1}{2} M_2^2}{1 + \frac{\gamma-1}{2} M_1^2} \right]^{\frac{\gamma+1}{2(\gamma-1)}}$$

Then either the k-factor based on dynamic pressure

$$k_{se} = \frac{1 - \frac{p_2}{p_1}}{\frac{\gamma}{2} \left( \frac{p_1}{p_1} \right) M_1^2}$$

or the k-factor based on impact pressure

$$k_{se}^+ = \frac{1 - \frac{p_2}{p_1}}{1 - \frac{p_1}{p_1}}$$

can be calculated.

Singularities are encountered where  $A_2$  becomes very large ( $\lambda \rightarrow 0$ ) and where  $M_1$  becomes very small ( $M_1 \rightarrow 0$ ). Noting that  $N_2$  and  $M_2$  become zero when  $\lambda = 0$  for any value of  $M_1$ , the entire energy in the jet,  $(P_1 - p_1)$ , is dissipated in the expansion to  $p_2 = p_1$ . Since  $k_{se}^+ = 1.0$  at  $\lambda = 0$ ,

$$k_{se} = \frac{1 - (p_2/p_1)}{\frac{\gamma}{2} \left( \frac{p_1}{p_1} \right) M_1^2} \quad \text{at } \lambda = 0.$$

Numerical realities make the use of  $k_{se}$  or  $k_{se}^+ = 1.0$  at  $\lambda = 0$  recommended practice for all  $\lambda < 0.0001$ .

Any compressible fluid flowing adiabatically assumes a constant density character at Mach numbers below 0.1. Consequently, the incompressible Carnot-Borda equation for a sudden expansion loss can be used as the asymptotic value for  $k_{se}$  and  $k_{se}^+$  at  $M_1 < 0.1$ .

The relationship between the k-factors based on dynamic pressure or impact pressure are shown in Figure 18 for all subsonic sudden expansions of a perfect gas with  $\gamma = 1.4$ . Although either k-factor definition is equally accurate, physical conceptualization of the loss as an extension of the incompressible case seems easier based on impact pressure,  $k_{se}^+$ .

When the efflux from duct  $A_1$  is supersonic ( $M_2 > 1.0$ ) for the choked condition,  $M_1 = 1.0$ , the sudden enlargement equation can be solved for the effective step face-to-jet static pressure ratio as a function of  $M_2$

$$\frac{p_e}{p_1} = \left( \frac{\lambda}{1-\lambda} \right) \left( \frac{\gamma+1}{2} \right)^{1/2} \left\{ \frac{1 + \gamma M_2^2}{M_2 \left( 1 + \frac{\gamma-1}{2} M_2^2 \right)^{1/2}} - \left( \frac{\gamma+1}{2} \right)^{1/2} \right\}$$

The total pressure loss calculation in this underexpanded flow regime simplifies to

$$\frac{p_2}{p_1} = \frac{\lambda}{M_2} \left[ \frac{1 + \frac{\gamma-1}{2} M_2^2}{\frac{\gamma+1}{2}} \right]^{\frac{\gamma+1}{2(\gamma-1)}}$$

An iterative solution can then be performed to determine the  $M_2, p_e/p_1$  pair compatible with the given duct discharge conditions  $P_1, p_1$ . Assuming a final subsonic Mach number,  $M_2 < 1.0$ , the terminal conditions must conform to

$$\frac{\dot{m} \sqrt{T}}{P_2 A_2} = \sqrt{\frac{\gamma g_c}{R}} \frac{M_2}{\left( 1 + \frac{\gamma-1}{2} M_2^2 \right)^{\frac{\gamma+1}{2(\gamma-1)}}}$$

The k-factors for the supersonic sudden expansion can be easily determined from the constant pressure ratio of the jet as

$$k_{se} = \frac{1 - \frac{P_2}{P_1}}{0.36980}$$

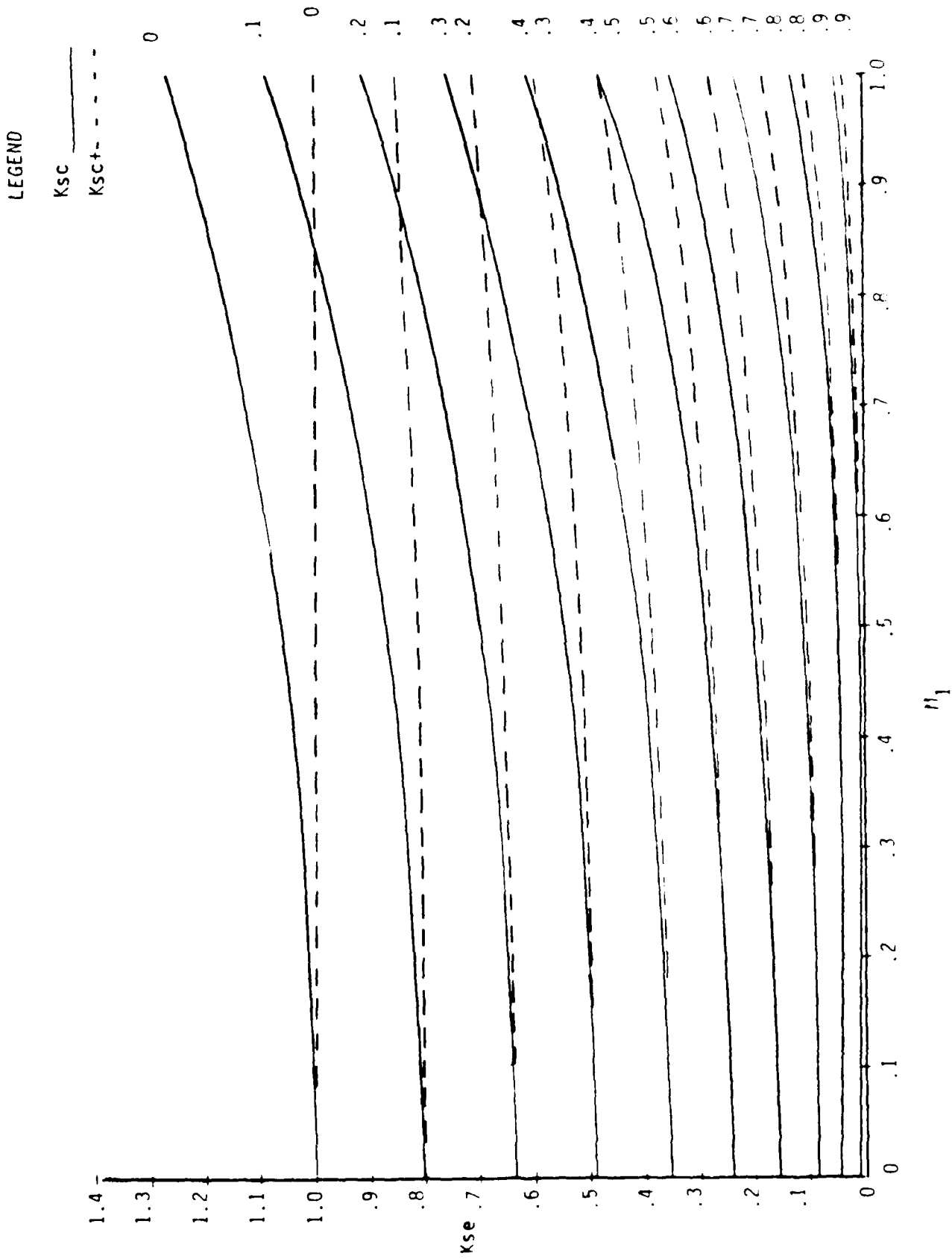
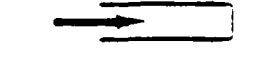
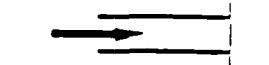
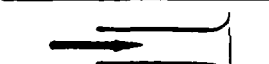

FIGURE 18 SUDDEN EXPANSION OF COMPRESSIBLE TURBULENT FLOW  $\gamma = 1.40$

Since the Borda-Carnot derivation is unconcerned with the duct shape, the quality of fit for the sudden expansion model indicates that duct shape is a secondary effect, as shown in Table IV. Variations in the discharge port geometry have a negligible effect on the sudden expansion loss. Even gradually expanding ducts with divergence angles exceeding about 45° experience flow separation which behaves essentially like an abrupt enlargement. The concept can be extended to include the separated flow (vena contracta) at sharp-edged entrances or forward facing steps. The physics of the sudden expansion model are helpful in understanding the modeling of the k-factors for sudden contractions and sharp-edged orifices.

Table IV.  
Loss k-factor for pipe exits. Reference (24)

| <u>Fitting</u>  | <u>Description</u> | <u>k-factor</u> |
|---|--------------------|-----------------|
|    | Projecting         | 1.0             |
|    | Sharp edged        | 1.0             |
|  | Rounded            | 1.0             |
| <u>Sudden Contraction</u>   |                    |                 |

Many investigators have studied the flow modeling of a duct entrance from a fluid reservoir or an abrupt area reduction within a duct. Adiabatic flow from an infinite reservoir into a re-entrant duct (Borda mouthpiece), Figure 19, can be accurately modeled one-dimensionally by conserving mass, momentum, and energy between the fluid reservoir and the vena contracta,

$$C_c = \frac{\left(1 + \frac{\gamma-1}{2} M_c^2\right)^{\frac{\gamma}{\gamma-1}} - 1}{\gamma M_c^2}$$

where

$$\lim_{M_c \rightarrow 0} C_c = \frac{\left(1 + \frac{\gamma-1}{2} M_c^2\right)^{\frac{1}{\gamma-1}} - 1}{2} = \frac{1}{2} \quad \text{or}$$

$$k_{se} = \frac{1 - \frac{P_2}{P_1}}{0.47172}$$

for  $\gamma = 1.4$ .

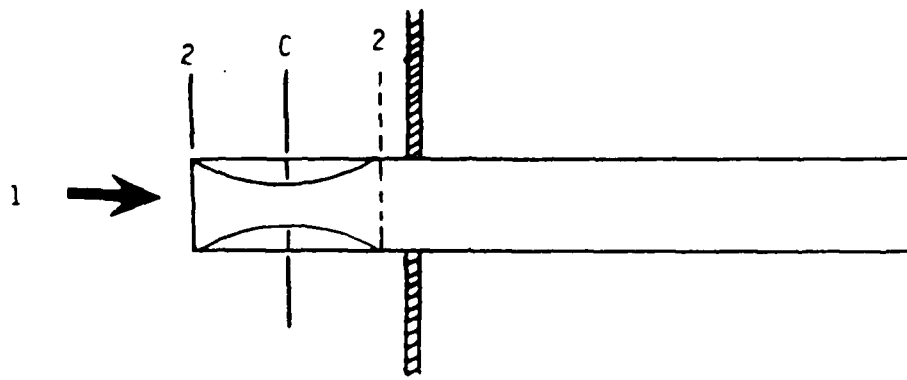

FIGURE 19 RE-ENTRANT INLET IN A FLUID RESERVIOR

The total pressure loss in this type of entering (accelerating) flow is relatively small because the conversion of pressure to velocity (as in a nozzle) is a stable process. Consequently, the assumption of inviscid flow between the reservoir (station 1) and the vena contracta (station c) is appropriate. Then the sudden expansion model for compressible adiabatic flow can be employed to evaluate the total pressure loss for flow reattachment. This modified Hughes and Safford analysis predicts a  $1.0 < k_{sc} < 1.095$  range for compressible flow into a Borda mouthpiece. Dodge (24) reports a range of k-factors from 0.68 to 2.5 for incompressible flow depending upon inlet edge conditions (modified corners to sharp). This large discrepancy with empirical k-factor values suggests a shortcoming of the one-dimensional analysis as it applies to sudden contraction losses. The marked curvature of the vena contracta flow compromises the accuracy of the one-dimensional assumption.

As the re-entrant length of the tube decreases to zero, the Borda mouthpiece is transformed into a sharp-edged inlet. The entrance flow no longer develops in isolation from the reservoir wall, so the momentum analysis must be modified. Reaction of the flow with the wall assists turning, and the incompressible contraction coefficient increases to about 0.6. Miller (5) provides dramatic data for this effect as tube wall thickness increases for a re-entrant inlet. The momentum equation no longer defines the total pressure loss explicitly. The Hughes and Safford equation

$$k_{sc} = \frac{1}{C_v^2 C_c^2} - \frac{2}{C_c} + 1$$

predicts  $k_{sc} = 1.00$  for a Borda mouthpiece and  $k_{sc} = 0.56$  for a sharp-edged inlet from the flow characteristics in Table V.

Table V.  
Characteristics for incompressible flow in duct  
entrances and exits. Reference (25)

| <u>Restriction</u>   | <u><math>C_v</math></u> | <u><math>C_c</math></u> | <u><math>C_D</math></u> |
|----------------------|-------------------------|-------------------------|-------------------------|
| re-entrant inlet     | 0.98                    | 0.52                    | 0.51                    |
| sharp-edged entrance | 0.80                    | 1.00                    | 0.80                    |
| duct discharge       | 1.00                    | 1.00                    | 1.00                    |

Benedict, et. al., (26) propose a generalized equation based on discharge coefficient to more accurately represent sudden contraction losses in constant density flows with an approach velocity

$$k_{sc} = \left( \frac{1}{C_D^2} - 1 \right) \left[ 1 - \left( \frac{A_2}{A_1} \right)^2 \right]$$

If  $A_2/A_1$  is taken to represent  $C_c$  for a re-entrant inlet,  $k_{sc} = 2.08$  is predicted, which better represents the empirical value. A  $k_{sc} = 0.56$  is still predicted for a sharp-edged entrance where  $A_1$  is very large with respect to the duct area. If a baseline total pressure loss coefficient is defined for a sudden contraction as

$$k_{sc}^* = \frac{1}{C_D^2} - 1$$

then the influence of the contraction ratio can be formulated as

$$k_{sc} = k_{sc}^* \left[ 1 - \left( \frac{A_2}{A_1} \right)^2 \right]$$

In many composite restrictions the flow at the entrance or through a sudden contraction occurs at nearly constant density. Then, for most practical applications to gas turbine internal flow systems, an incompressible equation is sufficiently accurate. For  $\Lambda < 0.3$ , which includes most entrances and many sudden contractions within restrictions, the recommended equation is

$$k_{sc} = 0.5781 (1 - \Lambda^2)$$

If more accuracy is required or when  $\Lambda > 0.3$ , the least squares curve fit from the test data of Benedict, et. al, (26) should be used

$$k_{sc} = 0.57806 + 0.39543 \Lambda^{1/2} - 4.53854 \Lambda \dots \\ \dots + 14.24265 \Lambda^{3/2} - 19.22214 \Lambda^2 + 8.54038 \Lambda^{5/2}$$

These data represent sudden contraction characteristics for constant density flow into long ducts where complete reattachment is assured. If the duct contraction length is short,  $(L/MD)_{sc} < 3$ , the "long hole" correction presented under orifice restrictions should be applied to  $k_{sc}$ . The effect of compressibility increased the experimental value for  $k_{sc}$  as much as 12% for subsonic flow (26). Considering the uncertainties associated with data, installation, and environment the constant density model for sudden contractions is justified.

The sudden contraction model discussed so far applies only to tubes or entrances which are aligned with the approaching flow and have sharp inlet edges. Figure 20 provides corrections obtained for entrances oblique to the approaching flow. One curve applies to a sudden contraction with the downstream duct normal to the step or wall which is at an angle to the approaching flow. The other curve applies to a sudden contraction with the downstream duct at an angle to the step or wall which is perpendicular to the approaching flow. Figure 21 provides a correction factor which accounts for rounding or edge break effects on sudden contraction characteristics. Then the general contraction coefficient can be found as:

$$k_{sc} = C_a C_r k_{sc}^* (1 - \Lambda^2).$$

If better analytical precision is required, reference (27) for sudden duct enlargements and reference (28) for sudden duct contractions can be used for restriction modeling.

TAKEN FROM N.A.T.E. REP. 143  
 KNIGHT AND WALKER

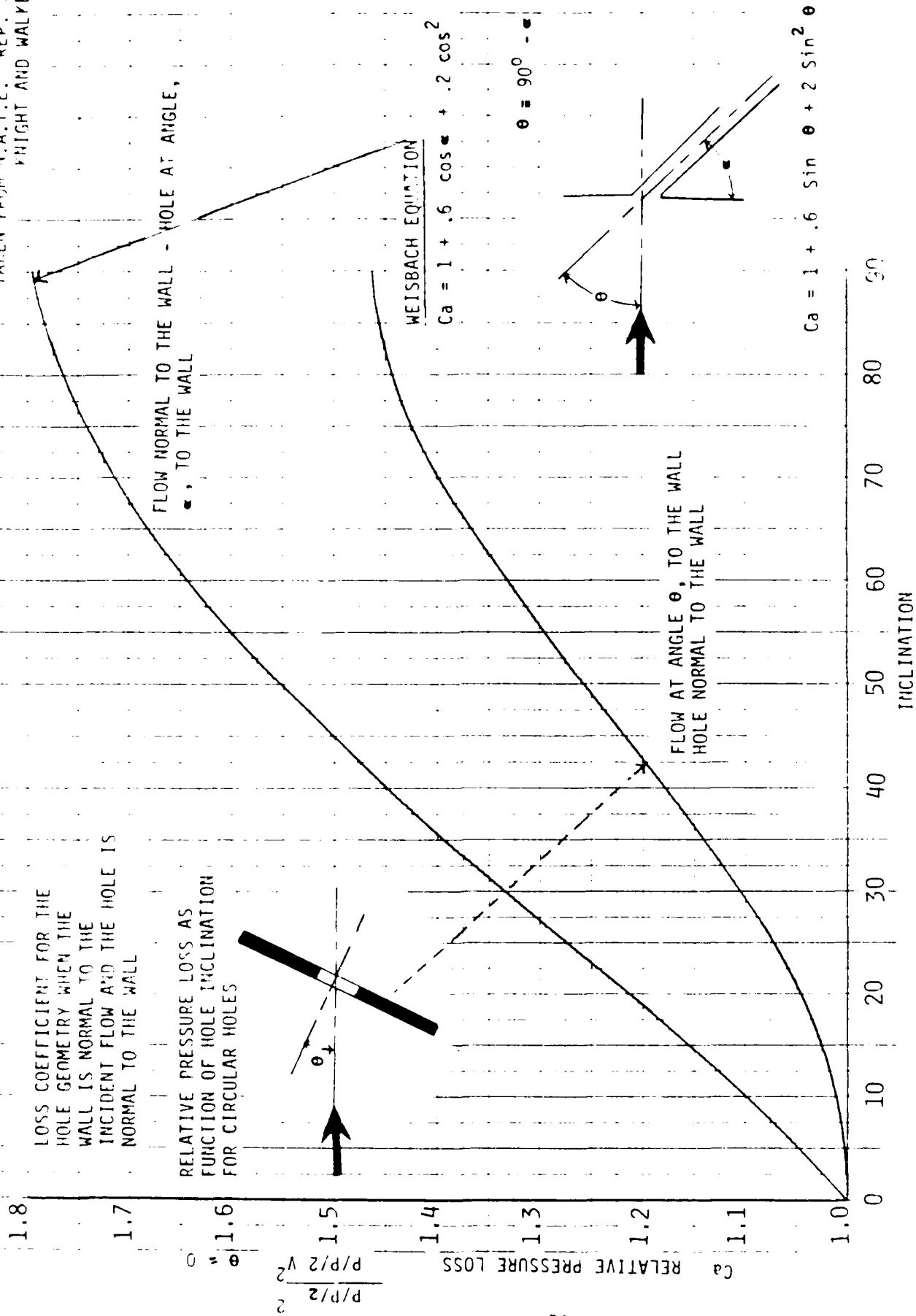

FIGURE 20 EFFECT OF ORIFICE AND INLET ANGULARITY WITH RESPECT TO APPROACH FLOW. REFERENCES (8) AND (13)

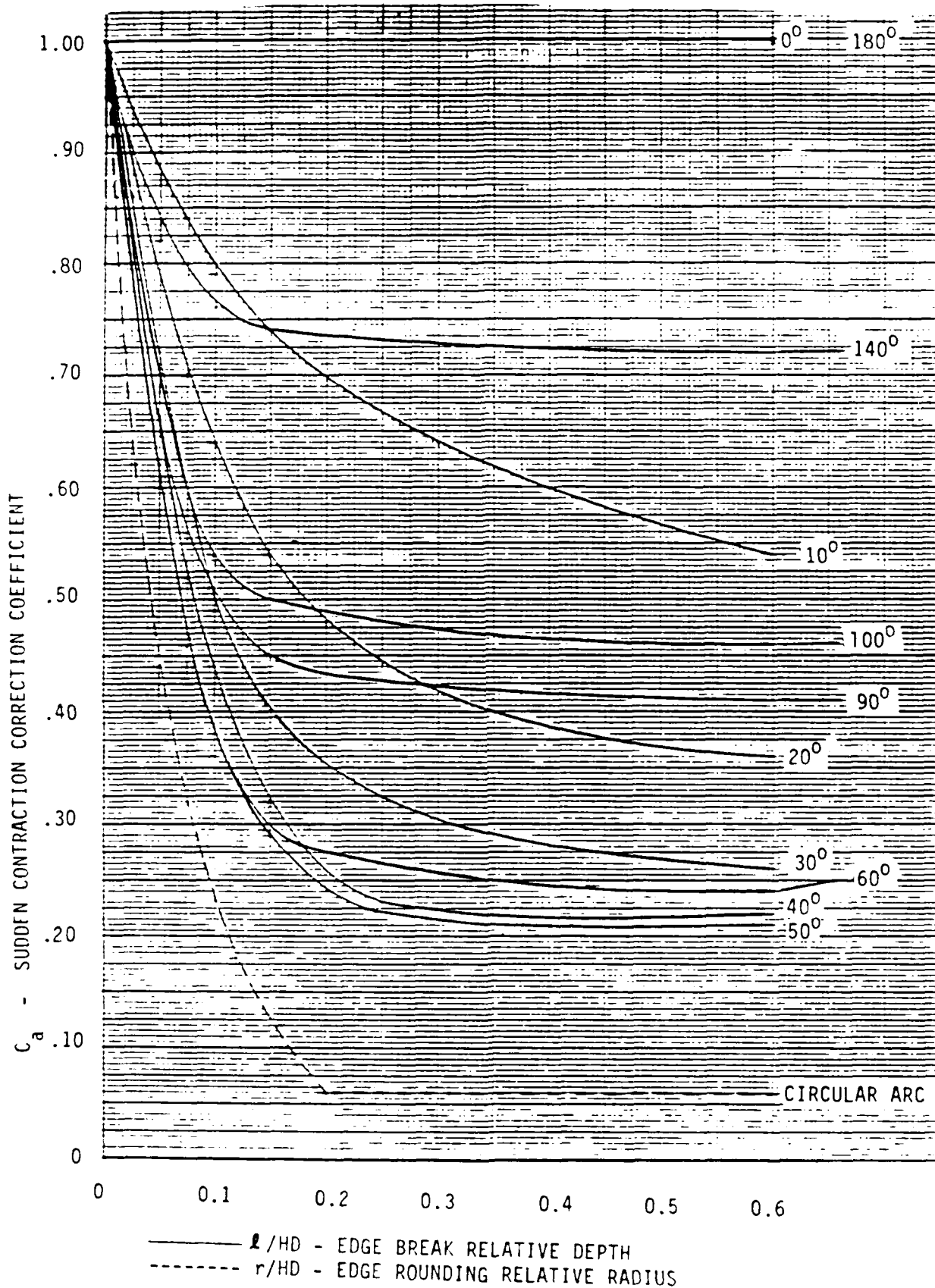

FIGURE 21 EFFECT OF INLET EDGE CONDITION ON SUDDEN CONTRACTION LOSS. REFERENCE (13)

## VI. TOTAL PRESSURE LOSS COEFFICIENTS FOR ORIFICES

Orifice type restrictions in gas turbine internal flow systems ordinarily consist of a thin end wall through which a hole permits flow communication between considerably larger upstream and downstream ducts. The inlet to an orifice is abrupt and relatively sharp so that significant flow separation results. A typical orifice is diagrammed in figure 22.

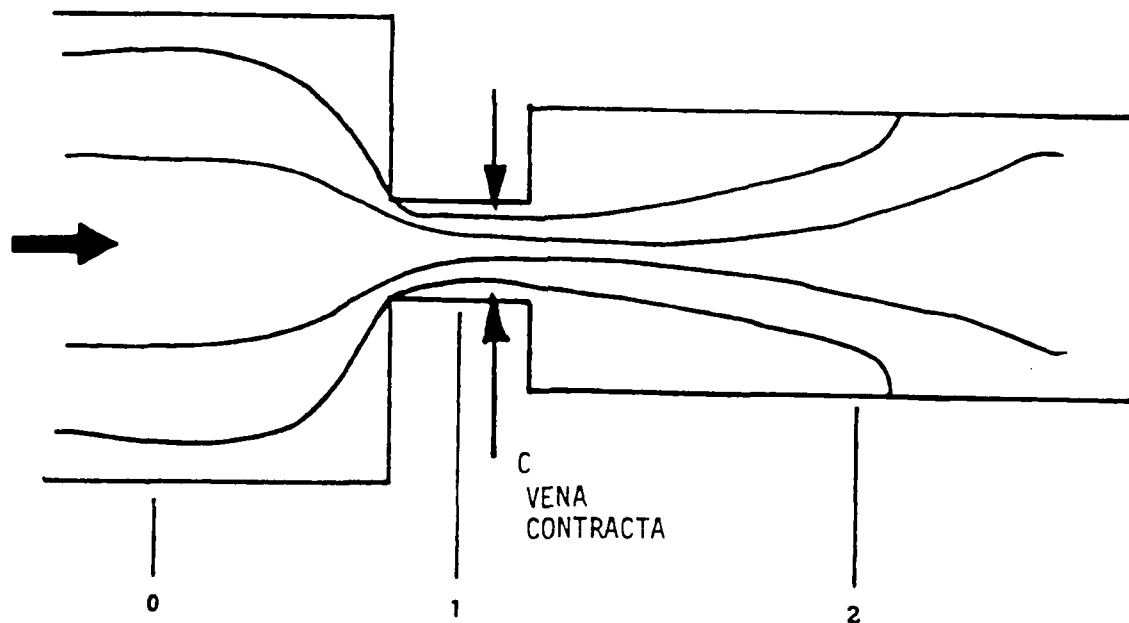

FIGURE 22. SCHEMATIC FOR A TYPICAL ORIFICE RESTRICTION.

The flow characteristic that distinguishes an orifice from a long hole or a nozzle is the inability of the vena contracta, which is induced by the sharpness of the sudden contraction, to isolate itself by flow reattachment to the wall before the sudden expansion. Consequently, the orifice flow model must combine a sudden contraction and a sudden expansion which are modified to account for interactions with the special flow processes that occur at the entrance and the exit. The conventional procedure has been to add a modifying k-factor,  $k_{\ell}$ , which incorporates the interactive effects of upstream and downstream duct geometry with the correction required to account for the sustained separation of the flow through the hole. Consideration of the small wall friction loss can be included. Since the complex flow processes in the formation and dissolution of the vena contracta are only qualitatively understood, the orifice model is based upon empirical correlations for

$$k_{\theta} = k_{sc} + k_{\ell} + 4f \ell/HD + k_{se}$$

When the length of the small hole connecting a sudden enlargement is less than three hydraulic diameters, the vena contracta formed at the entrance to the orifice may not reattach within the short length. Without reattachment the sudden contraction becomes sensitive to flow conditions in the downstream enlargement. Separated flow at the orifice exit does not conform to the model established for a sudden expansion. An orifice model for incompressible flow to account for the process interactions caused by separation was derived by Dodge (24):

$$k_{sc} = k_{sc}^* [1-\Lambda] \quad \text{where } k_{sc}^* = 0.5$$

$$k_{\ell} = k_{\ell}^* [k_{sc} k_{se}]^{1/2} \quad \text{where } k_{\ell}^* \text{ is defined by Figure 23}$$

$$k_{se} = k_{se}^* [1-\lambda]^2 \quad \text{where } k_{se}^* = 1.0$$

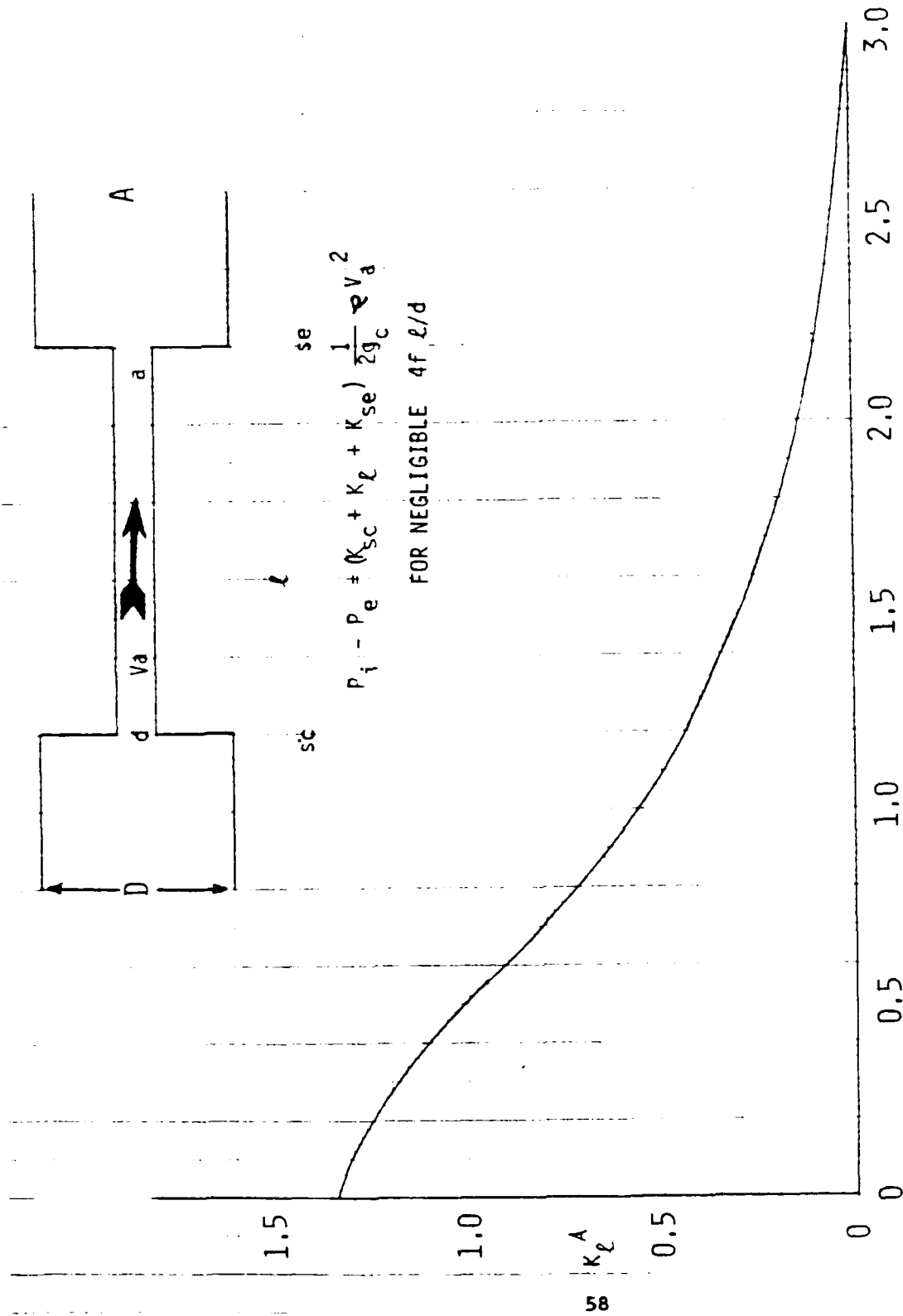

FIGURE 23 LONG HOLE EFFECT. REFERENCE (24)

The vena contracta loss for incompressible flow through thick static orifices is evaluated by the empirical  $k_{\ell}^*$  of Figure 23. The influence of approach velocity and limited downstream expansion on the severity and extent of separation is corrected by

$$k_{\ell} = k_{\ell}^* [1-\Lambda]^{1/2} [1-\lambda]$$

The performance of orifices is buffered against effects from adjacent restrictions or tangent geometry by 1.5 hydraulic diameters or more of straight duct. The orifice characteristics are unaffected by Reynolds numbers in the hole that are greater than  $1 (10^5)$ .

Fluid compressibility exerts the strongest influence on high velocity flow through orifices. Contrary to the invariant behavior of the vena contracta of incompressible flow, the separation process is a function of the orifice pressure ratio in a compressible flow. The level of separation decreases as the pressure ratio,  $r$ , decreases. Although the expanded vena contracta area reduces the extent of the separated flow, the orifice losses with compressible flow are not decreased.

The most familiar characteristic of compressibility associated with orifice performance is shown in Figure 24. The flow through orifices differs from that through most restrictions in the supercritical behavior. When a typical restriction becomes critical ( $M = 1.0$  at some flow location), the flow parameter,  $\Phi$ , is maximized with respect to pressure ratio. The restriction is said to be choked at that location. Then the adiabatic flow rate becomes linearly dependent upon upstream total pressure, but independent of further reductions in restriction pressure ratio,  $r$ . On the contrary, however, an orifice can be critical at its vena contracta ( $M_c = 1$ ) and still exhibit an increasing flow parameter,  $\Phi$ , as the pressure ratio,  $r$ , is reduced. This behavior results from the influence that the downstream static pressure exerts on the "free-jet" vena contracta. In highly separated flows like those encountered with sharp-edged contractions and flow angularity, these compressibility effects become exaggerated for thin (short duct) orifices.

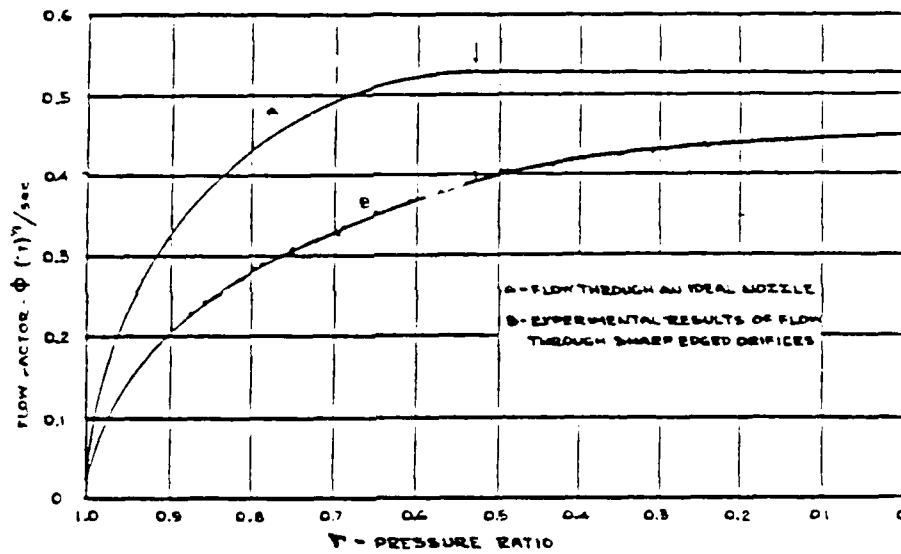

FIGURE 24 FLOW THROUGH SHARP-EDGED ORIFICES COMPARED TO FLOW THROUGH AN IDEAL NOZZLE. (REFERENCE (29))

for thicker orifices in coaxial flow, the vena contracta environment is isolated from the downstream static conditions. For short holes with an  $l/D > 4$  choking will rarely occur at the vena contracta. In any event, thick orifices and relatively large orifices, where small area changes reduce the separation, are less sensitive to the supercritical compressibility effects. Small edge-breaks or leading edge radii radically suppress separation. The geometry of an orifice:

sudden contraction ratio,  $A_1/A_0 = \Lambda$

inlet flow angularity,  $C_a$

leading edge sharpness,  $C_r$

orifice thickness,  $l/HD$

sudden expansion ratio,  $A_1/A_2 = \lambda$

affects orifice performance in either incompressible or compressible flows. However, the orifice pressure ratio only influences the performance of orifices in compressible flow<sup>4</sup>. The greatest effect is seen on thin, static orifices operating in or near the supercritical regime.

#### Synthesis of an Orifice Model

Orifices encountered in gas turbine internal flow systems can encompass any combination of geometric variables important to flow capacity, Figure 25. Therefore, a comprehensive model for orifice flow characteristic prediction is required. The model proposed by Dodge (24) is amenable to modifications to achieve this flexibility:

$$k_o = k_{sc} + k_l + 4f(l/HD) + k_{se}$$

#### Sudden Contraction

$$k_{sc} = C_a C_r k_{sc}^* [1-\Lambda]$$

where flow angularity correction is provided by  $C_a = y(\theta, \text{flow direction})$ , Figure 20, and leading edge sharpness correction is provided by  $C_r = y(\alpha, l_{sc}/HD)$  for chamfers or  $C_r = z(r/D)$  for radii from Figure 21.

<sup>4</sup>Cavitating effects can be important in liquid flows.

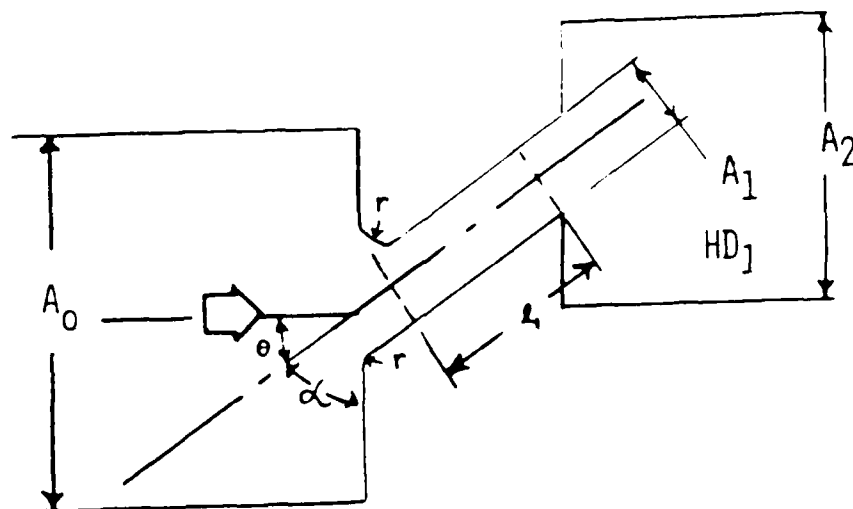

FIGURE 25 GENERALIZED ORIFICE

The sudden contraction model for orifice applications is based on the experimental work of Weisbach testing short orifices and Freeman testing nozzles with water. Both of these investigators obtained contraction coefficient and discharge coefficient data which resulted in

$$k_{sc}^* = 0.5 \quad \text{for small } \Lambda.$$

Notice that the sudden contraction model is not the same model selected from reference (26). The sudden contraction data acquired by Benedict, Carlucci, and Swetz were for entrances to long ducts where separation reattachment and velocity profile recovery were attained.

#### Vena Contracta

The "long hole" k-factor employed by Dodge (24) corrects for the interactions of contraction and expansion geometry with the incompressible free-jet vena contracta

$$k_L = (C_a C_r)^{1/2} k_L^* [1-\Lambda]^{1/2} [1-\lambda]$$

where  $k_L^*$  is given for a static orifice by Figure 23.

#### Sudden Expansion

The sudden expansion model of Carnot-Borda is used as recommended for incompressible flow

$$k_{se}^+ = k_{se}^* [1-\lambda]^2$$

where

$$k_{se}^* = 1.0$$

The application of the sudden expansion k-factor to the impact pressure, P-p, at the orifice exit, rather than the dynamic pressure recommended for the sudden contraction and vena contracta losses, generalizes the expansion model to the compressible flow regime. This approximation is very good for large expansion ratios.

Although the Dodge (24) model for orifice characteristics is specifically for incompressible flow, it can be applied to certain thick and/or large hole orifices in compressible flow with good accuracy. A technique has been developed to adapt it to thin, small orifices where compressibility effects are most pronounced.

Orifice Characteristics for Compressible Flow

The thin plate,  $\lambda/D < 0.1$ , static orifice,  $\Lambda = \lambda < 0.1$ , is the most familiar category that exhibits strong compressible flow effects near and in the supercritical regime. It can be demonstrated numerically, however, that small blunting of the leading edge, slight lengthening of the hole ( $\lambda/D > 1.2$ ), or restricting the contraction and/or expansion ratio can mitigate the compressible vena contracta characteristic quite rapidly. Consequently, a relatively limited range of orifice geometry requires a more sophisticated compressible flow analysis than that provided by the Dodge model. The extension of the Dodge model to these special orifice flows and the range of applicability will be discussed.

Perry (29) demonstrated that highly separated compressible flow through thin-plate, static orifices behaves linearly in the subcritical region

$$\Phi = \sqrt{m (1-r^2)}$$

when modeled in elliptical coordinates

$$\Phi = m \sqrt{r}$$

where  $m = 0.216$  for air. Perry (29) represented the supercritical region as

$$\Phi = (a + nr) \sqrt{1-r}$$

which in elliptical coordinates becomes

$$\phi = (a + n\sqrt{1-r^*})^2 (1 - \sqrt{1-r^*})$$

where  $a = 0.449$  and  $n = 0.241$  for air.

The slope of the supercritical flow model was found to be 88% of the subcritical model slope at the choking pressure ratio,

$$m_c^* = 0.88 m$$

The compressible flow model proposed by Perry (29) for thin, static orifices can be generalized to model the limited range of orifices where vena contracta compressibility is important, Table VI. The orifice model by Dodge can be used to generate the incompressible flow characteristics for the specific orifice geometry desired.<sup>5</sup> A common slope for the compressible and the incompressible flow can be found near  $r = 0.87$  as

$$m = \left(\frac{\phi}{r}\right)_r \sim 0.87$$

Then

$$n = \sqrt{\frac{\phi^*}{1-r^*}} \left\{ \frac{1}{1-r^*} \left[ \frac{1}{2} - 0.88 \left( \frac{r^*}{1+r^*} \right) \right] \right\}$$

and

$$a = \sqrt{\frac{\phi^*}{1-r^*}} - nr^*$$

where

$$r^* = \left(\frac{2}{\gamma+1}\right)^{\gamma/(\gamma-1)} \text{ for } \gamma = 1.4$$

and

$$\phi^* = m [1-(r^*)^2]$$

<sup>5</sup>A flow characteristic curve generator similar to DU1 in BC88 PLUS can be used to solve for  $\phi$  at  $r$  using the  $k$ -factors from the Dodge orifice model.

Table VI.  
Applicable range of the compressible flow parameters  
 for orifice models based on Perry (29).

$$k_{sc} > 0.4$$

$$k_Q > 0.65$$

$$\lambda < 0.125 \quad \text{which is the same as} \quad (k_{se}^+ > 0.765)$$

$$m < 0.26$$

It can be seen from the supercritical orifice model that  $a = \Phi$  when  $r = 0$ . Therefore,  $a > 0.532$  for air cannot be allowed.

Other more stringent flow modeling restrictions place tighter limits on the applicable range of parameters. The entrance flow must be severely separated, and the orifice hole must be short enough to preclude flow reattachment within the hole. The orifice exit area ratio must provide a large expansion so that the flow reattaches in the far downstream field of the tangent duct. If these stipulations as quantified in Table V are met, the compressible flow characteristics of the orifice can generally be modeled satisfactorily over the complete range of pressure ratio as outlined.

Example Calculations for Generalized Orifice Flow Characteristics

Two orifices have been modeled to demonstrate the calculation procedures for

- 1) A conventional thick-plate orifice with nozzle-like characteristics.
- 2) A generalized thin orifice with definite vena contracta compressibility characteristics.

The detailed calculations for restriction 1 and restriction 2 are located in the Derivations section of the Appendix. The Allison Gas Turbine Engines version of a flow characteristic curve generator program titled DUI was utilized to calculate the airflow parameter,  $\Phi$ , as a function of the total pressure ratio,  $P_U/P_D$ . Constant values for restriction k-factors were used with the exception of the FANNO wall friction calculation. The Moody

correlation for Fanning friction factor was calculated at each flow condition on the curve.

Restriction 1 is nozzle-like according to the low internal k-factors. The flow characteristic curve generated by DUI calculations of the Dodge model represents the thick-plate orifice performance very well. This orifice will exhibit a classical choked flow characteristic because of the minimal entrance separation and the internal flow reattachment.

Restriction 2 exhibits definite thin orifice-like performance according to the combination of high k-factors for the loss elements and relatively low slope in the elliptical parameters. Since sustained entrance flow separation with free jet vena contracta characteristics are indicated, the flow curve will not choke but will continue to rise in the supercritical regime. Therefore, the Perry model was used to predict the orifice flow curve. The Dodge model was calculated in the DUI program to determine the orifice baseline performance in the low pressure ratio,  $P_U/P_D$ , or "incompressible" regime.

The orifice flow characteristics are derived directly from the component loss k-factors in the DUI calculation. However, if a curve of k-factor versus flow parameter is required for inserting an orifice into a component restriction of a more extensive geometry, the "kurve" data can be developed from the flow curve at each  $P_U/P_D$  as follows:

$$\Phi \rightarrow \left(\frac{g}{p}\right)_1 \quad (\text{see note})$$

$$k = \frac{1 - (P_D/P_U)}{\left(\frac{g}{p}\right)_1}$$

The "kurve 1" in the example DUI input is the Perry static orifice curve of k factor versus flow factor,  $\Phi$ . This data file contains all of the elements for orifice modeling using the procedures of Dodge, Perry, or "k curve".

Note

The calculation of  $\left(\frac{q}{p}\right)_1$  from  $\Phi$  requires the solution of the implicit equation:

$$\Phi = \sqrt{\frac{\gamma g_c}{R}} \frac{M}{\left(1 + \frac{\gamma-1}{2} M^2\right)^{\frac{\gamma+1}{2(\gamma-1)}}}$$

for Mach number. The  $\left(\frac{q}{p}\right)_1$  can be found directly from

$$\left(\frac{q}{p}\right)_1 = \frac{\gamma}{2} \frac{M^2}{\left(1 + \frac{\gamma-1}{2} M^2\right)^{\frac{\gamma}{\gamma-1}}}$$

## REFERENCES

- (1) Ward-Smith, A.J. INTERNAL FLUID FLOW, The Fluid Dynamics of Flow in Pipes and Ducts, Clarendon Press, Oxford, Great Britain, 1980.
- (2) Benedict, R.P., and N.A. Carlucci. "Flow With Losses", JOURNAL OF ENGINEERING FOR POWER, TRANS. ASME, Series A, Vol. 87, January, 1965, pp. 37-49.
- (3) Introductory Memorandum on the Pressure Losses in Internal Flow Systems; Item No. 69016; Vol. 1, GENERAL, COMPRESSIBLE FLOW RELATIONSHIPS, STRAIGHT PIPES; Fluid Mechanics, Internal Flow; Engineering Sciences Data Unit, London, England, July, 1969.
- (4) Pressure Losses In Curved Ducts: Single Bends; Item No. 83037; Vol. 2, BENDS, BRANCHES AND JUNCTIONS; Fluid Mechanics, Internal Flow; Engineering Sciences Data Unit, London, England, April, 1985.
- (5) Miller, Donald S. INTERNAL FLOW SYSTEMS, BHRA Fluid Engineering Series, Volume 5, British Hydromechanics Research Association, BHRA Fluid Engineering, England, 1978.
- (6) Pressure Losses In Curved Ducts: Interaction Factors For Two Bends In Series; Item No. 77009; Vol. 2, BENDS, BRANCHES AND JUNCTIONS; Fluid Mechanics, Internal Flow; Engineering Sciences Data Unit, London, England, May, 1977.
- (7) Ito, H. "Pressure Losses In Smooth Pipe Bends", JOURNAL OF BASIC ENGINEERING, Trans. ASME, Series D, Vol.82, No. 1, March, 1960, pp. 131-143.
- (8) Pressure Loss and Flow Characteristics of Various Air Passage Configurations - General Design Data, TECHNICAL DESIGN REPORT NO. G.20, Rolls-Royce Limited, Derby, England, 1962.
- (9) SAE AEROSPACE APPLIED THERMODYNAMICS MANUAL, SAE Committee A-9, Aero-space Environmental Control Systems, Technical Division, Society of Automotive Engineers, New York, January, 1962.
- (10) Ito, H. "Friction Factors for Turbulent Flow in Curved Pipes", JOURNAL OF BASIC ENGINEERING, Trans. ASME, Series D, Vol. 81, No. 2, June, 1959, pp. 123-134.
- (11) "Air Duct Design", Chapt. 31, ASHRAE 1977 FUNDAMENTALS HANDBOOK, American Society of Heating, Refrigeration, and Air Conditioning Engineers, 1977, pp. 31.25-31.36.

- (12) Hager, W.H. "An Approximate Treatment of Flow in Branches and Bends", PROCEEDINGS OF THE INSTITUTION OF MECHANICAL ENGINEERS, Vol. 198C, No. 4, 1984, pp. 63-69.
- (13) Idel'chik, I.E. HANDBOOK OF HYDRAULIC RESISTANCE, (Coefficients of Local Resistance and of Friction), AEC-TR-6630, (Gosudarstvennoe Energeticheskoe Izdatel'stvo, Moskva-Leningrad), 1960.
- (14) Henry, John R. Design of Power-Plant Installations. PRESSURE-LOSS CHARACTERISTICS OF DUCT COMPONENTS, NACA WR L-208, (Formerly NACA ARR L4F26), 1944.
- (15) Ward-Smith, A.J. PRESSURE LOSSES IN DUCTED FLOWS, Butterworths, London, England, 1971.
- (16) Miller, Donald S. INTERNAL FLOW - A Guide to Losses In Pipe and Duct Systems, British Hydromechanics Research Association, Cranfield, U.K., 1971.
- (17) Ower, E., and R.C. Pankhurst. THE MEASUREMENT OF AIR FLOW, Pergamon Press, Oxford, England, 1966.
- (18) Vazsonyi, Andrew. "PRESSURE LOSS IN ELBOWS AND DUCT BRANCHES", Trans. ASME, Vol. 66, No. 1, April, 1944, pp. 177-182.
- (19) Williamson, J.V., and T.J. Rhone. "Dividing Flow in Branches and Wyes", JOURNAL OF HYDRAULICS DIVISION, Proceedings of the ASCE, Vol. 99, No. HY5, 1973, pp. 747-769.
- (20) Pressure Losses in Three-Leg Pipe Junctions: Dividing Flows; Item No. 73022; Vol. 2, BENDS, BRANCHES AND JUNCTIONS; Fluid Mechanics, Internal Flow; Engineering Sciences Data Unit, London, England, October, 1973.
- (21) Pressure Losses in Three-Leg Pipe Junctions: Combining Flows; Item No. 73023; Vol. 2, BENDS, BRANCHES AND JUNCTIONS; Fluid Mechanics, Internal Flow; Engineering Sciences Data Unit, London, England, October, 1973.
- (22) Gardel, A. "Les Pertes de Charge Dans Les Ecoulements an Travers de Branchements en Te, (Pressure Drops In Flows Through T-Shaped Pipe Fitting)", BULLETIN TECHN. DE LA SUISSE ROMANDE, Vol. 83, No. 9, pp. 123-130, No. 10, pp. 143-148, 1957. (French)
- (23) Benedict, R.P., J.S. Wyler, J.A. Dudek, and A.R. Gleed. GENERALIZED FLOW ACROSS AN ABRUPT ENLARGEMENT, Paper No. 75-WA/FM-1, ASME, Winter Annual Meeting, Houston, Texas, November 30-December 5, 1975.
- (24) Dodge, Louis. "Fluid Throttling Devices", FLOW RESISTANCE IN PIPING AND COMPONENTS, Product Engineering, Reprint R109, McGraw-Hill, New York, New York, March 30, 1964, pp. 14-20.

- (25) Howell, Glen W., and Terry M. Weathers. "3.0 Fluid Mechanics", AEROSPACE FLUID COMPONENT DESIGNERS' HANDBOOK, RPL-TDR-64-25, Volume 1, TRW Systems Group, Redondo Beach, California, February, 1970.
- (26) Benedict, R.P., N.A. Carlucci, and S.D. Swetz. "Flow Losses in Abrupt Enlargements and Contractions", JOURNAL OF ENGINEERING FOR POWER, Trans. ASME, Series A, Vol. 88, January, 1966, pp. 73-81.
- (27) Flow Through a Sudden Enlargement of Area in a Duct; Item No. 72011; Vol. 4, DUCT EXPANSIONS, DUCT CONTRACTIONS; Fluid Mechanics, Internal Flow; Engineering Sciences Data Unit, London, England, April, 1972.
- (28) Pressure Losses in Flow Through a Sudden Contraction of Duct Area; Item No. 78007; Vol. 4, DUCT EXPANSIONS, DUCT CONTRACTIONS; Fluid Mechanics, Internal Flow; Engineering Sciences Data Unit, London, England, April, 1981.
- (29) Perry, Jr., J.A. "Critical Flow Through Sharp-Edged Orifices", TRANS. ASME, Vol. 71, October, 1949, pp. 757-764.

BIBLIOGRAPHY

The following bibliography is excerpted from 565 references and is divided into component loss subjects:

- Turns and Bends
- Branches--Dividing/Combining
- Sudden Area Changes
- Orifices--Static and Rotating
- Theoretical/Empirical Analysis
- Literature Surveys

Consequently, some of the references appear in more than one category.

URNS AND BENDS

- \*\*"AIR DUCT DESIGN", CHAPT. 31, ASHRAE 1977 FUNDAMENTALS HANDBOOK, AMERICAN SOCIETY OF HEATING, REFRIGERATION, AND AIR CONDITIONING ENGINEERS, 1977, PP. 31.25-31.36.
- \*\*FLOW OF FLUIDS THROUGH VALVES, FITTINGS, AND PIPE, TECHNICAL PAPER NO 410, CRANE CO., CHICAGO, ILLINOIS, 1969.
- \*\*"FLUID DYNAMICS", SECTION 3, PROPULSION MANUAL-FUNDAMENTAL INFORMATION, VOLUME III, THE MARTIN COMPANY, JANUARY 27, 1958.
- \*\*PRESSURE LOSS AND FLOW CHARACTERISTICS OF VARIOUS AIR PASSAGE CONFIGURATIONS - GENERAL DESIGN DATA, TECHNICAL DESIGN REPORT NO. G.20, ROLLS-ROYCE LIMITED, DERBY, ENGLAND, 1962.
- \*\*"PRESSURE LOSSES OF VENTILATION FITTINGS", SECTION DDS3801-2, CODE 415, DESIGN DATA SHEET, DEPARTMENT OF THE NAVY, BUREAU OF SHIPS, WASHINGTON, D.C., 22 JULY 1950.
- PRESSURE LOSSES FOR INCOMPRESSIBLE FLOW IN SINGLE BENDS, ITEM NO. 67040, ENGINEERING SCIENCES DATA UNIT, LONDON, ENGLAND, 1967.
- PRESSURE LOSSES IN CURVED DUCTS: INTERACTION FACTORS FOR TWO BENDS IN SERIES, ITEM NO. 77009, VOL. 2, BENDS, BRANCHES AND JUNCTIONS, FLUID MECHANICS, INTERNAL FLOW, ENGINEERING SCIENCES DATA UNIT, LONDON, ENGLAND, MAY, 1977.
- PRESSURE LOSSES IN CURVED DUCTS: COILS, ITEM NO. 77029, VOL. 2, BENDS, BRANCHES AND JUNCTIONS, FLUID MECHANICS, INTERNAL FLOW, ENGINEERING SCIENCES DATA UNIT, LONDON, ENGLAND, MARCH, 1981.
- PRESSURE LOSSES IN CURVED DUCTS: SINGLE BENDS, ITEM NO. 83037, VOL. 2, BENDS, BRANCHES AND JUNCTIONS, FLUID MECHANICS, INTERNAL FLOW, ENGINEERING SCIENCES DATA UNIT, LONDON, ENGLAND, APRIL, 1985.
- PRESSURE LOSSES FOR INCOMPRESSIBLE FLOW IN SINGLE BENDS, ENGG SCIENCE DATA ITEM NO. 67040, 1967.
- SAE AEROSPACE APPLIED THERMODYNAMICS MANUAL, SAE COMMITTEE A-9, AEROSPACE ENVIRONMENTAL CONTROL SYSTEMS, TECHNICAL DIVISION, SOCIETY OF AUTOMOTIVE ENGINEERS, NEW YORK, JANUARY, 1962.
- ABRAMOVICH, G.N. "FLUID MOTION IN CURVED DUCTS", TRANSACTIONS OF THE CENTRAL AERO-AND-HYDRODYNAMICAL INSTITUTE, MOSCOW, USSR, 1935 (NACA TRANSLATION)
- ADLER, M. "FLOW OF FLUIDS IN CURVED PIPES", ZEITSCHRIFT FUR ANGEWANDTE MATHEMATIK UND MECHANIK, VOL. 14, OCTOBER, 1934, PP. 257-275. (GERMAN)
- ADLER, M. FLOW OF FLUIDS IN CURVED PIPES, A E C TR-2011, US ATOMIC ENERGY COMMISSION, 1934.
- AHMED, S., AND E. BRUNDRETT. "PERFORMANCE OF TURNING VANES IN A COAXIAL CONDUIT ELBOW", ASME PAPER 69-FE-32, AMERICAN SOCIETY MECHANICAL ENGINEERS, 1969.

- AKIYAMA, M., AND K.C. CHENG. "BOUNDARY VORTICITY METHOD FOR LAMINAR FORCED CONVECTION HEAT TRANSFER IN CURVED PIPES", INTERNATIONAL JOURNAL OF HEAT AND MASS TRANSFER, VOL. 14, 1971, PP. 1659-1675.
- ANGLESEA, W.T., D.J.B. CHAMBERS, AND R.C. JEFFREY. "MEASUREMENTS OF WATER/STEAM PRESSURE DROP IN HELICAL COILS AT 179 BARS", PAPER 12, SYMPOSIUM ON MULTI-PHASE FLOW SYSTEMS, UNIVERSITY OF STATHCLYDE, U.K., APRIL, 1974.
- APTHORPE, D.M., AND J.S. MEDES. CALCULATION OF PRESSURE DROP IN PIPE BENDS, REPORT NEDR/10/0036, BABCOCK POWER LTD, LONDON, MARCH 20, 1981.
- ARONOV, I.Z. AN INCREASE OF THE CRITICAL REYNOLDS NUMBER DURING MOTION OF A FLUID IN BENT TUBES, FTD-TT-61-278, USAF FOREIGN TECHNOLOGY DIVISION, WRIGHT-PATTERSON AIR FORCE BASE, OHIO, 1962.
- BAYLIS, J.A. "EXPERIMENTS ON LAMINAR FLOW IN CURVED CHANNELS OF SQUARE SECTION", JOURNAL OF FLUID MECHANICS, TRANS. ASME, VOL. 48, NO. 3, AUGUST, 1971, PP. 417-422.
- BECK, C. "LAMINAR FLOW FRICTION LOSSES THROUGH FITTINGS, BENDS, AND VALVES", JOURNAL OF THE AMERICAN SOCIETY OF NAVAL ENGINEERS, VOL. 56, NO. 2, MAY, 1944, PP. 235-271.
- BECK, C. "LAMINAR FLOW FRICTION LOSSES IN 90 DEGREE CONSTANT CIRCULAR CROSS-SECTION BENDS", JOURNAL OF THE AMERICAN SOCIETY OF NAVAL ENGINEERS, VOL. 56, NO. 3, 1944, PP. 366-388.
- BEIJ, K.H. "PRESSURE LOSSES FOR FLUID FLOW IN 90 DEGREE PIPE BENDS", PAPER 1110, JOURNAL OF RESEARCH OF THE NATIONAL BUREAU OF STANDARDS, VOL. 21, NO. 1, JULY, 1938, PP. 1-18.
- BENEDICT, R.P., AND N.A. CARLUCCI. HANDBOOK OF SPECIFIC LOSSES IN FLOW SYSTEMS, PLENUM PRESS, NEW YORK, 1966.
- BENSON, R.S., AND D. WOOLLATT. "COMPRESSIBLE FLOW LOSS COEFFICIENTS AT BENDS AND T-JUNCTIONS", ENGINEER, VOL. 221, 1966, PP. 153-159.
- BINNI, A.M., AND D.P. HARRIS. "THE USE OF CASCADES AT SHARP ELBOWS IN WATER PIPES", ENGINEER, VOL. 90, 1ST SEPTEMBER, PP. 232-235, 1950.
- BIDULEY, A. "MEANS FOR DECREASING THE LOSS IN SHARP BENDS", SCHWEIZERISCHE BAUZEITUNG, VOL. 118, NO. 8, AUGUST 23, 1941. (GERMAN)
- BONNINGTON, S.T. MEASUREMENTS OF THE PRESSURE LOSSES IN COPPER FITTINGS, BHRA REPORT RR719, BRITISH HYDROMECHANICS RESEARCH ASSOCIATION CRANFIELD, U.K., 1962.
- BOYCE, B.E., J.G. COLLIER, AND J. LEVY. "HOLD-UP PRESSURE DROP MEASUREMENTS IN THE TWO-PHASE FLOW OF AIR-WATER MIXTURES IN HELICAL COILS. CO-CURRENT GAS-LIQUID FLOW, PLENUM PRESS, 1969, PP. 203-263.
- BROWN, A.I. "FRICTION OF AIR IN ELBOWS", POWER PLANT ENGINEERING, VOL. 36, AUGUST 15, 1932, PP 630-631.

- CHENG, K.C., AND M. AKIYAMA. "LAMINAR FORCED CONVECTION HEAT TRANSFER IN CURVED RECTANGULAR CHANNELS", INTERNATIONAL HEAT AND MASS TRANSFER, VOL. 13, 1970, PP. 471-490.
- CHENG, K.C., R.C. LIN, AND J.W. OU. "FULLY DEVELOPED LAMINAR FLOW IN CURVED RECTANGULAR CHANNELS", JOURNAL OF FLUID ENGINEERING, TRANS. ASME, VOL. 198, NO. 1, MARCH, 1976, PP. 41-48.
- CORP, C.I., AND H.T. HARTWELL. EXPERIMENTS ON LOSS OF HEAD IN U. S. AND TWISTED-S PIPE BENDS, BULLETIN UNIVERSITY OF WISCONSIN, ENGINEERING SERIES, VOL. 66, UNIVERSITY OF WISCONSIN, EXPERIMENTAL STATION.
- DALLE-DONNE, M., AND F.H. BOWDITCH. "HIGH TEMPERATURE HEAT TRANSFER", NUCLEAR ENGINEERING, VOL. 8, 1963, PP. 20-29.
- DEAN, W.R., "FLUID MOTION IN A CURVED CHANNEL", PROCEEDINGS OF THE ROYAL SOCIETY OF LONDON, SERIES A, VOL. 121, 1928, PP. 402-420.
- DEAN, W.R. "THE STREAMLINE MOTION OF FLUID IN CURVED PIPE", PHILISOPHICAL MAGAZINE, (7) VOL. 4, 1928, P. 673.
- DIMMOCK, N.A. THE DEVELOPMENT OF A SIMPLY CONSTRUCTED CASCADE CORNER FOR CIRCULAR CROSS-SECTION DUCTS, NGTE MEMORANDUM M.78, NATIONAL GAS TURBINE ESTABLISHMENT, U.K., 1950.
- DIMMOCK, N.A. "CASCADE CORNERS FOR DUCTS OF CIRCULAR CROSS-SECTION", BRITISH CHEMICAL ENGINEERING, VOL. 2, NO. 6, JUNE, 1957, PP. 302-307.
- \*\*DODGE, LOUIS. "FLUID THROTTLING DEVICES", FLOW RESISTANCE IN PIPING AND COMPONENTS, PRODUCT ENGINEERING, REPRINT R109, MCGRAW-HILL, NEW YORK, NEW YORK, MARCH 30, 1964, PP. 14-20.
- FRITSCH, D., AND H. RICHTER. "FLOW RESISTANCE IN CURVED ROUGH PIPE LINES", FORSCHUNG A.D. GEB. D. ING. W., VOL. 4, NOVEMBER/DECEMBER, 1933, PP. 307-314. (GERMAN)
- \*\*GERLACH, C.R. LOW PRESSURE LOSS DUCT BEND, SOUTHWEST RESEARCH INSTITUTE, NASA GEORGE C. MARSHALL SPACE FLIGHT CENTER, HUNTSVILLE, ALABAMA, 7 MARCH 1969.
- GIESECKE, F.E. FRICTION OF WATER IN PIPES AND FITTINGS, BULLETIN NO. 1759, UNIVERSITY OF TEXAS, 1917.
- GIESECKE, F.E., C.P. REMING, AND J.W. KNUDSON, JR. FRICTION OF WATER IN ELBOWS, BULLETIN NO. 2712, UNIVERSITY OF TEXAS, 1929.
- GIESECKE, F.E., AND W.H. BADGETT. "LOSS OF HEAD IN COPPER PIPE FITTINGS", HEATING, PIPING, AND AIR CONDITIONING, JUNE, 1932.
- GRAY S. A SURVEY OF EXISTING INFORMATION ON THE FLOW IN BENT CHANNELS AND THE LOSSES INVOLVED, POWER JETS REPORT NO. R. 1104, POWER JETS (RESEARCH AND DEVELOPMENT), JUNE, 1945.
- \*\*HAGER, W.H. "AN APPROXIMATE TREATMENT OF FLOW IN BRANCHES AND BENDS", PROCEEDINGS OF THE INSTITUTION OF MECHANICAL ENGINEERS, VOL. 1980, NO. 4, 1984, PP. 63-69.



- IMANAMI, S. I., T. KANE, AND H. SATO. "STUDY ON FLOW IN RIGHT ANGLED PIPE FITTINGS." BULLETIN JAPANESE SOCIETY OF MECHANICAL ENGINEERS, VOL. 11, NO. 55, 1969, PP. 1041-1061.
- JENGER, J. J. "METHODS FOR ESTIMATING PRESSURE LOSSES IN DUCTS, REPORT # 109, AIRPLANE DIVISION, CURTISS WRIGHT CORPORATION, ROBERTSON, MISSOURI, FEBRUARY 26, 1942.
- KAMINDEL, C. A. "EDITOR." FLUID FLOW DATA BOOK, GENERAL ELECTRIC COMPANY, SCHENECTADY, NEW YORK.
- KEHNER, W. J., AND R. A. SMITH. "TESTING OF GAS TURBINE HIGH VELOCITY TEST SYSTEM." CATHOLIC UNIVERSITY OF AMERICA, WASHINGTON, D. C., NACA ARMT ENGINEERING CENTER, CONTRACT NO. 901761, AUGUST, 1962.
- KEE, S. L. H., AND F. H. WELLS. "PRESSURE LOSSES FOR FLUID FLOW IN CURVED PIPES." RESEARCH PAPER 865, JOURNAL OF RESEARCH OF THE NATIONAL BUREAU OF STANDARDS, VOL. 16, 1932, PP. 89-114.
- KIRKBAUM, H. "LOSS OF ENERGY IN MITRE BEND." TRANSACTIONS OF THE AMERICAN SOCIETY OF MECHANICAL ENGINEERS, BULLETIN NO. 3, MONTECITTO TECHNICAL CENTER, PISCATAWAY, N. J., SAME TRANSLATION 1935.
- KIRKBAUM, H. "LOSS OF ENERGY IN MITER BEND." TRANSACTIONS OF THE AMERICAN SOCIETY OF MECHANICAL ENGINEERS, BULLETIN NO. 3, ASME, NEW YORK, 1935.
- KITTELING, C. R., AND D. S. POWELL. "RESISTANCE COEFFICIENTS FOR LAMINAR AND TURBULENT FLOW THROUGH ONE-HALF INCH VALVES AND FITTINGS." TRANS. ASME, VOL. 79, 1957, PP. 1759-1766.
- KUJITA, T. "VALVE LOSS FOR THE DEFLECTION OF FLUID FLOW WITH SMALL ENERGY LOSSES." NACA TM 1100, 1951.
- KUBAIR, V. J., AND N. R. FULOOD. "FLOW OF NEWTONIAN FLUIDS IN ARCHIMEDIAN SPIRAL TUBE COILS: CORRELATION OF THE LAMINAR, TRANSITION AND TURBULENT FLOW." INDIAN JOURNAL OF TECHNOLOGY, VOL. 4, 1966, PP. 1-8.
- KUBAIR, V. J., AND N. R. FULOOD. "PRESSURE DROP AND HEAT TRANSFER IN SPIRAL TUBE COILS." INDIAN JOURNAL OF TECHNOLOGY, VOL. 11, NO. 9, 1966, PP. 75.
- KUBAIR, V. J., AND N. R. FULOOD. "NON-ISOTHERMAL PRESSURE DROP DATA FOR LIQUID FLOW IN HELICAL COILS." INDIAN JOURNAL OF TECHNOLOGY, VOL. 3, 1966, PP. 5-7.
- KUBAIR, V. J., AND N. R. FULOOD. "HEAT TRANSFER TO NEWTONIAN FLUIDS IN COOLED PIPES IN LAMINAR FLOW." INTERNATIONAL JOURNAL OF HEAT AND MASS TRANSFER, VOL. 9, 1966, PP. 63-75.
- KUBAIR, V. J., AND C. B. S. VARRIER. "PRESSURE DROP IN HELICAL TUBE COILS." TRANSACTIONS OF THE INDIAN INSTITUTION OF CHEMICAL ENGINEERS, VOL. 14, 1961-62, PP. 93-97.
- KUTATELADZE, S. S., AND V. M. BORISHANSKII. "A CONCISE HISTORY OF HEAT TRANSFER, CHAPTER 7.5, PERAMON PRESS, 1966.

LAMB, OWEN P., AND JAMES S. HOLDHUSEN. INVESTIGATION OF AIRCRAFT DUCTING COMPONENTS AT HIGH SUBSONIC SPEEDS, USAF WADC TR 56-187, FLUIDDYNE ENGINEERING CORP., SEPTEMBER, 1956.

LEE, I.J., AND G. WEEKS. INVESTIGATION INTO SECONDARY FLOW IN MITRED BENDS, REPORT NO. 182, DEPARTMENT OF AERONAUTICAL ENGINEERING, UNIVERSITY OF BRISTOL, ENGLAND, JUNE, 1974.

MADISON, R.D., AND J.R. PARKER. "PRESSURE LOSSES IN RECTANGULAR ELBOWS", TRANS. ASME, VOL. 58, 1936, PP. 167-176.

MATTHEW, G.D. "SIMPLE APPROXIMATE TREATMENT OF CERTAIN INCOMPRESSIBLE DUCT FLOW PROBLEMS INVOLVING SEPARATION", JOURNAL OF MECHANICAL ENGINEERING SCIENCE, VOL. 17, NO. 2, 1975, PP. 57-64.

MAZUROV, D.YA., AND G.V. ZAKHAROV. "A STUDY OF THE AERODYNAMICS OF TUBULAR COILS", THERMAL ENGINEERING, VOL. 14, NO. 2, 1967, PP. 60-64.

MCHARG, J.W. "AIR TESTS ON A 12-INCH CASCADE BEND", NEL REPORT 243, NATIONAL ENGINEERING LABORATORY, U.K., AUGUST, 1966.

••METZGER, D.E., C.W. PLEVICH, AND C.S. FAN. "PRESSURE LOSS THROUGH SHARP 180 DEG TURNS IN SMOOTH RECTANGULAR CHANNELS", JOURNAL OF ENGINEERING FOR GAS TURBINES AND POWER, TRANS. ASME, VOL. 106, JULY, 1984, PP. 677-681.

MILLER, DONALD S. INTERNAL FLOW - A GUIDE TO LOSSES IN PIPE AND DUCT SYSTEMS, BRITISH HYDROMECHANICS RESEARCH ASSOCIATION, CRANFIELD, U.K., 1971.

••MILLER, DONALD S. INTERNAL FLOW SYSTEMS, BHRA FLUID ENGINEERING SERIES, VOLUME 5, BRITISH HYDROMECHANICS RESEARCH ASSOCIATION, BHRA FLUID ENGINEERING, ENGLAND, 1978.

MOORE, JOHN, AND JOAN G. MOORE. "A CALCULATION PROCEDURE FOR THREE-DIMENSIONAL, VISCOUS, COMPRESSIBLE DUCT FLOW, PART 2-STAGNATION PRESSURE LOSSES IN A RECTANGULAR ELBOW", (ASME PAPER 79-WA/FE-51), FLOW IN PRIMARY, NONROTATING PASSAGES OF TURBOMACHINES, PROCEEDINGS OF WINTER ANNUAL MEETING, ASME, 1979, PP. 75-88. TJ267 F56.

MURAKAMI, M., K. MORI, AND K. SANO. "A STUDY ON THE HYDRAULIC LOSS OF TUBULAR COILS", BULLETIN OF THE JAPANESE SOCIETY OF MECHANICAL ENGINEERS, VOL. 14, NO. 78, DECEMBER, 1971, PP. 1296-1303.

MURAYAMI, M., Y. SHIMIZU, AND M. SHIRAGAMI. "STUDIES ON FLUID FLOW IN THREE-DIMENSIONAL BEND CONDUITS", BULLETIN OF THE JAPANESE SOCIETY OF MECHANICAL ENGINEERS, VOL. 12, NO. 54, DECEMBER, 1969, PP. 1369-1379.

MURAYAMI, M., H. SUEHIRO, AND H. ONO. "A STUDY ON HYDRAULIC LOSS OF SPIRALLY COILED TUBES", MEMOIRS FACULTY ENGINEERING, NAGOYA UNIVERSITY JAPAN, 1973, PP. 270-277.

- \*\*NAGLE, P., AND A. JAUMOTTE. "INFLUENCE OF SINGLE RESISTANCE FEATURES ON THE DISCHARGE COEFFICIENT FOR A STANDARDIZED ORIFICE, NOZZLE OR VENTURI, EXPERIMENTAL STUDY", PROMOCHEMIE ETUDES THERMIQUES ET AERAIQUES, VOL. 9E, NO. 1, JANUARY, 1978, PP. 34-47.  
(ROLLS-ROYCE TRANSLATION FROM THE FRENCH 1981)
- NORDELL, C.H. "CURVED FLOW IN CONDUITS OF CONSTANT CROSS-SECTION", OIL AND GAS JOURNAL, VOL. 39, NO. 1, MAY 16, 1940, PP. 117-124.
- PATANKAR, S.V., V.S PRATAP, AND D.B. SPALDING. "PREDICTION OF LAMINAR FLOW AND HEAT TRANSFER IN HELICALLY-COILED PIPES", J. FLUID MECH., VOL. 62, PP. 539-551, 1974.
- PATTERSON, G.N. NOTE ON THE DESIGN OF CORNERS IN DUCT SYSTEMS, R&M NO. 1773, BRITISH AERONAUTICAL RESEARCH COMMITTEE, 1937.
- PATTERSON, G.N. "CORNER LOSSES IN DUCTS", AIRCRAFT ENGINEERING, VOL. 9, NO. 2, AUGUST, 1937, PP. 205-208.
- PETUKHOV, B.S. "HEAT TRANSFER AND FRICTION IN TURBULENT PIPE FLOW WITH VARIABLE PHYSICAL PROPERTIES", ADVANCES IN HEAT TRANSFER, VOL. 6, ACADEMIC PRESS, 1970.
- PIGOTT, R.J.S. "PRESSURE LOSSES IN TUBING, PIPE, AND FITTINGS", TRANS. ASME, VOL. 72, 1950, PP. 679-688.
- PIGOTT, R.J.S. "LOSSES IN PIPES AND FITTINGS", TRANS. ASME, VOL. 79, NO. 8, 1957, PP. 1767-1783.
- RICHTER, H. "PRESSURE DROP IN CURVED SMOOTH PIPES", FORSCHUNGSARBEITEN, VOL. 338, HEFT, 1930. (GERMAN)
- RIPPEL, G.R., C.M. EIDIT, AND H.B. JORDAN. "TWO-PHASE FLOW IN A COILED TUBE", INDUSTRIAL ENGINEERING CHEMISTRY, PROCEEDINGS OF THE DESIGN DIVISION, VOL. 5, NO. 1, 1966, PP. 32-39.
- RODGERS, G.F.C., AND Y.R. MAYHEW. "HEAT TRANSFER AND PRESSURE LOSS IN HELICALLY COILED TUBES WITH TURBULENT FLOW", INTERNATIONAL JOURNAL OF HEAT AND MASS TRANSFER, VOL. 7, 1964, PP. 1207-1216.
- ROHSENOW, W.M. (ED) HANDBOOK OF HEAT TRANSFER, CHAPTER 7, MCGRAW HILL BOOK CO., 1973.
- RUFFELL, A.E. "THE APPLICATION OF HEAT TRANSFER AND PRESSURE DROP DATA TO THE DESIGN OF HELICAL COIL ONCE-THROUGH BOILERS", PAPER 15, SYMPOSIUM ON MULTI-PHASE FLOW SYSTEMS, UNIVERSITY STRATHCLYDE, U.K. APRIL, 1974.
- SALTER, C. "EXPERIMENTS ON THIN TURNING VANES", ARC R AND M 2469, AERONAUTICAL RESEARCH COUNCIL, U.K., 1946.
- SCHUBART, W. "FLOW IN CURVED PIPES", TRANSACTIONS OF THE MUNICH HYDRAULIC INSTITUTE, BULLETIN 3, MUNICH TECHNICAL UNIVERSITY, 1929, P. 121. (ASME TRANSLATION 1935)
- SEBAN, R.A., AND E.F. MCLAUGHLIN. "HEAT TRANSFER IN TUBE COILS WITH LAMINAR AND TURBULENT FLOW", INTERNATIONAL JOURNAL OF HEAT AND MASS TRANSFER, VOL. 6, 1963, PP. 387-395.

- SHCHUKIN, V.K. "CORRELATION OF EXPERIMENTAL DATA ON HEAT TRANSFER IN CURVED PIPES", THERMAL ENGINEERING, VOL. 16, NO. 1, 1969, PP. 72-76.
- \*\*SHIRAGAMI, NAOHIRO, AND ICHIRO INOUE. "PRESSURE LOSSES IN SQUARE SECTION BENDS", JOURNAL OF CHEMICAL ENGINEERING OF JAPAN, VOL. 14, NO. 3, 1981, PP. 173-177.
- SIEDER, E.N., AND G.E. TATE. "HEAT TRANSFER AND PRESSURE DROP OF LIQUIDS IN TUBES", INDUSTRIAL ENGINEERING CHEMISTRY, VOL. 28, NO. 12, 1936, PP. 1424-1435.
- \*\*SIMPSON, LARRY L. "SIZING PIPING FOR PROCESS PLANTS", CHEMICAL ENGINEERING, JUNE 17, 1968, PP. 192-214.
- SPALDING, W. "TESTS OF FLOW LOSS IN CURVED DUCTS", VDI ZEITUNG, VOL. 77, JANUARY-JUNE, 1933, PP. 143-148 (GERMAN).
- SPRENGER, M. "PRESSURE LOSSES IN 90 DEG BENDS FOR TUBES OR DUCTING OF RECTANGULAR CROSS-SECTIONS", BHRA REPORT 1027, BRITISH HYDROMECHANICS RESEARCH ASSOCIATION, CRANFIELD, U.K., 1969 (TRANSLATION FROM SCHWEIZERISCHE BAUTZEITUNG, VOL. 87, NO. 13, MARCH, 1969.)
- SRINIVASAN, P.S. FRICTIONAL EFFECTS IN COILS, M. SC. THESIS, UNIVERSITY OF SALFORD, U.K., 1968.
- SRINIVASAN, P.S., S.S. NANDAPURKAR, AND F.A. HOLLAND. "PRESSURE DROP AND HEAT TRANSFER IN COILS", THE CHEMICAL ENGINEER, NO. 218, 1968, PP. CE113-CE119.
- SRINIVASAN, P.S., S.S. NANDAPURKAR, AND F.A. HOLLAND. "FRICTION FACTORS FOR COILS", TRANSACTIONS OF THE INSTITUTE OF CHEMICAL ENGINEERS, VOL. 48, 1970, PP. 156-161.
- SRIVASTAVA, R.Y. STEADY AND UNSTEADY COMPRESSIBLE FLUID FLOW IN PIPE BENDS, PAPER NO. 28, PROCEEDINGS OF THE SYMPOSIUM ON INTERNAL FLOWS, UNIVERSITY OF SALFORD, UNITED KINGDOM, APRIL, 1971.
- \*\*SRIVASTAVA, R.K., B.Y. MURTHY, AND SUBIR KAR. "INVESTIGATION OF LOSSES DUE TO CHANGE OF DIRECTION OF INCOMPRESSIBLE FLOW", JOURNAL OF THE INSTITUTION OF ENGINEERS (INDIA) MECHANICAL ENGINEERING DIVISION, VOL. 58, MARCH, 1978, PP. 186-190.
- STEVENS, S.J., U.S.L. NAYAK, AND G.J. WILLIAMS. "THE INFLUENCE OF INLET CONDITIONS ON THE PERFORMANCE OF ANNULAR DIFFUSERS", PROCEEDINGS OF THE JOINT SYMPOSIUM ON DESIGN AND OPERATION OF FLUID MACHINERY, VOL. 1, COLORADO STATE UNIV., FORT COLLINS, JUNE 12-14, 1976, PP. 277-290.
- STUART, M.C., C.F. WARNER, AND H.C. ROBERTS. "PRESSURE LOSS CAUSED BY ELBOWS IN 8-INCH ROUND VENTILATING DUCT", ASHVE TRANSACTIONS, VOL. 48, 1942, P. 335.
- STUART, M.C., C.F. WARNER, AND H.C. ROBERTS. "THE EFFECT OF VANES IN REDUCING PRESSURE LOSS IN ELBOWS IN 7-INCH SQUARE VENTILATING DUCTS", ASHVE TRANSACTIONS, JANUARY, 1942; ALSO, HEATING, AND PIPING, AND AIR CONDITIONING, VOL. 14, SEPTEMBER 1943, PP. 466-473.

- TAYLOR, G. I. "THE CRITERIA FOR TURBULENCE IN CURVED PIPES".  
PROCEEDINGS OF THE ROYAL SOCIETY OF LONDON, SERIES A, VOL. 119,  
1929, PP. 243-249.
- TRUESDELL, L. C., AND R. J. ADLER. "NUMERICAL TREATMENT OF FULLY  
DEVELOPED LAMINAR FLOW IN HELICALLY COILED TUBES". AMERICAN  
INSTITUTION OF CHEMICAL ENGINEERS, VOL. 14, 1970, PP. 1010-1019.
- TUNSTALL, M. J., AND J. P. HARVEY. "THE EFFECT OF A SHARP BEND ON A  
FULLY DEVELOPED TURBULENT PIPE FLOW". JOURNAL OF FLUID MECHANICS,  
VOL. 34, 1968, PP. 595-607.
- TUVE, G. L., AND R. E. SPREngle. "ORIFICE DISCHARGE COEFFICIENT FOR  
VISCIOUS LIQUIDS". INSTRUMENTS, NOVEMBER, 1973, P. 101.
- VALENTINI, J. FLOYD, AND MARTIN R. COPE. "INVESTIGATION TO DETERMINE  
EFFECTS OF RECTANGULAR VORTEX GENERATORS ON THE STATIC PRESSURE  
DROP THROUGH A 90 DEG. CIRCULAR ELBOW". NACA RM L53G06, 1957.
- \*\*VAZZONI, ANDREW. "PRESSURE LOSS IN ELBOWS AND DUCT BRANCHES". TRANS.  
ASME, VOL. 86, NO. 2, APRIL, 1964, PP. 175-181.
- VOELKE, G. "EXPERIMENT TO DETERMINE THE LOSS AT RIGHT ANGLED PIPE  
TEES". THE HYDRAULIC LABORATORY PRACTICE, ED. G. P. FREEMAN. AMEN,  
NEW YORK, 1929, PP. 470-472.
- YIOYANNIDIS, G. G., AND H. W. MOU. "EXPERIMENTAL STUDY OF EFFECT OF  
VIBRATION ON FRICTION FACTOR IN FLOWS THROUGH CURVED PIPES".  
INDUSTRIAL ENGINEERING CHEMISTRY, PROCEEDINGS OF DESIGN AND  
DEVELOPMENT, VOL. 9, NO. 7, 1970, PP. 186-190.
- HARD SMITH, A. J. "THE FLOW AND PRESSURE LOSSES IN SMOOTH PIPE BENDS OF  
CONSTANT CROSS SECTION". JOURNAL OF THE ROYAL AERONAUTICAL SOCIETY,  
VOL. 67, NO. 631, 1963, PP. 437-447.
- HARD SMITH, A. J. "SUBSONIC ADIABATIC FLOW IN A DUCT OF CONSTANT CROSS  
SECTIONAL AREA". JOURNAL OF THE ROYAL AERONAUTICAL SOCIETY,  
FEBRUARY, 1964.
- HARD SMITH, A. J. "SOME ASPECTS OF FLUID FLOW IN DUCTS, (PHD THESIS),  
UNIVERSITY OF OXFORD, UNITED KINGDOM, 1968  
(PUBLISHED BY BUTTERWORTHS 1971)
- \*\*HARD SMITH, A. J. "PRESSURE LOSSES IN DUCTED FLOWS, BUTTERWORTHS,  
LONDON, ENGLAND, 1971
- HARD SMITH, A. J. "COMPONENT INTERACTIONS AND THEIR INFLUENCE ON THE  
PRESSURE LOSSES IN INTERNAL FLOW SYSTEMS". PROCEEDINGS OF THE  
INSTITUTION OF MECHANICAL ENGINEERS, VOL. 190, NO. 8276, 1976.
- \*\*HARD SMITH, A. J. "INTERNAL FLUID FLOW, THE FLUID DYNAMICS OF FLOW IN  
PIPES AND DUCTS, CLARENDON PRESS, OXFORD, GREAT BRITAIN, 1980
- HESKE, JOHN R. "PRESSURE LOSS IN DUCTS WITH COMPOUND ELBOWS, NACA WP  
W 39, (FORMERLY NACA ARR), FEBRUARY, 1943.
- HESKE, JOHN R. "EXPERIMENTAL INVESTIGATION OF VELOCITY DISTRIBUTIONS  
DOWNSTREAM OF SINGLE DUCT BENDS, NACA TN 1471, 1948

WHITE, C. M. STREAMLINE FLOW THROUGH CURVED CHANNELS. PROCEEDINGS OF THE ROYAL SOCIETY OF LONDON, SERIES A, VOL. 110, 1926, PP. 887-893.

••WILBURN, STAFFORD B. AN INVESTIGATION OF FLOW IN CIRCULAR AND ANNULAR 90 DEG BENDS WITH A TRANSITION IN CROSS SECTION. NACA TN 1200. LANGLEY AERONAUTICAL LABORATORY, LANGLEY FIELD, VIRGINIA, AUGUST 1951.

WINTER, F. D. COMPARATIVE TESTS OF THICK AND THIN TURNING VANES IN THE RANSFORD WIND TUNNELS. ARC R AND M 2509. AERONAUTICAL RESEARCH COUNCIL, 1944.

••WRIGHT, R. H. NEW DATA FOR THE DESIGN OF ELBOWS IN DUCT SYSTEMS. GENERAL ELECTRIC REVIEW, NO. 46, NOVEMBER 1952, PP. 24-29.

••WU, T. S. AND CHEN, H. UNSTEADY FLOW IN A CORNARY BEND. RETURN FLOW PASSAGE AT A FUNCTION OF REYNOLDS NUMBER. JOURNAL OF BASIC ENGINEERING, TRANSACTIONS ASME, MARCH, 1970, P. 197.

YARNALL, E. L. AND DE WAGNER, J. FLOW OF WATER AROUND BENDS IN PIPELINES. TRANSACTIONS OF THE AMERICAN SOCIETY OF CIVIL ENGINEERS, VOL. 61, 1945, PP. 1018-1042.

YOUNG, A. E. CORNERS AND FLOW LOSS. TESTS OF HIGH SPEED FLOW IN RIGHT ANGLE VEE BENDS OF RECTANGULAR CROSS SECTION. R&M NO. 2066. BRITISH AIR FORCE, 1947.

ZANER, F. J. AND F. JORDAN. THE HEAD LOSSES DUE TO VARIOUS COMBINATIONS OF THE BENDS. BHRA REPORT MP 264. BRITISH HYDROMECHANICAL RESEARCH ASSOCIATION, CRANFIELD, UNITED KINGDOM, FEBRUARY, 1967.

TOTAL NUMBER OF REFERENCES FOR TURNS AND BENDS

14.

FLOW RESTRICTION LOSS FACTOR BIBLIOGRAPHY

BRANCHES - DIVIDING/COMBINING

- "AIR DUCT DESIGN", CHAPT 31, ASHRAE 1977 FUNDAMENTALS HANDBOOK, AMERICAN SOCIETY OF HEATING, REFRIGERATION, AND AIR CONDITIONING ENGINEERS, 1977, PP. 31.25-31.36.
- PRESSURE LOSSES IN THREE-LEG PIPE JUNCTIONS: DIVIDING FLOWS; ITEM NO. 73022; VOL. 2, BENDS, BRANCHES AND JUNCTIONS; FLUID MECHANICS, INTERNAL FLOW; ENGINEERING SCIENCES DATA UNIT, LONDON, ENGLAND, OCTOBER, 1973.
- PRESSURE LOSSES IN THREE-LEG PIPE JUNCTIONS: COMBINING FLOWS; ITEM NO. 73023; VOL. 2, BENDS, BRANCHES AND JUNCTIONS; FLUID MECHANICS, INTERNAL FLOW; ENGINEERING SCIENCES DATA UNIT, LONDON, ENGLAND, OCTOBER, 1973.
- SAE AEROSPACE APPLIED THERMODYNAMICS MANUAL, SAE COMMITTEE A-9, AEROSPACE ENVIRONMENTAL CONTROL SYSTEMS, TECHNICAL DIVISION, SOCIETY OF AUTOMOTIVE ENGINEERS, NEW YORK, JANUARY, 1962.
- ALLEN, J., AND B. ALBINSON. "AN INVESTIGATION OF THE MANIFOLD PROBLEM FOR INCOMPRESSIBLE FLUIDS WITH SPECIAL REFERENCE TO THE USE OF MANIFOLDS FOR CANAL LOCKS", PROCEEDINGS OF THE INSTITUTION OF CIVIL ENGINEERS, VOL. 4, NO. 1, PART 3, 1955, PP. 114-138.
- BENEDICT, R.P., AND N.A. CARLUCCI. HANDBOOK OF SPECIFIC LOSSES IN FLOW SYSTEMS, PLENUM PRESS, NEW YORK, 1966.
- BENSON, R.S., AND D. WOODLATT. "COMPRESSIBLE FLOW LOSS COEFFICIENTS AT BENDS AND T-JUNCTIONS", ENGINEER, VOL. 221, 1966, PP. 153-159.
- BONNINGTON, S.T. MEASUREMENTS OF THE PRESSURE LOSSES IN COPPER FITTINGS, BHRA REPORT RR719, BRITISH HYDROMECHANICS RESEARCH ASSOCIATION CRANFIELD, U.K., 1962.
- CROW, D.A., AND R. WHARTON. "A REVIEW OF LITERATURE ON THE DIVISION AND COMBINATION OF FLOW IN CLOSED CONDUITS", TN 937, BRITISH HYDROMECHANICS RESEARCH ASSOCIATION, JANUARY, 1968.
- DANIELS, C.M., AND H.A. PELTON. "PRESSURE LOSSES IN HYDRAULIC BRANCH-OFF FITTINGS", PRODUCT ENGINEERING, VOL. 30, NO. 29, 1959, PP. 60-61.
- DODGE, LOUIS. "FLUID THROTTLING DEVICES", FLOW RESISTANCE IN PIPING AND COMPONENTS, PRODUCT ENGINEERING, REPRINT R109, MCGRAW-HILL, NEW YORK, NEW YORK, MARCH 30, 1964, PP. 14-20.
- GARDEL, A. "LES PERTES DE CHARGE DANS LES ECOULEMENTS AN TRAVERS DE BRANCHEMENTS EN T. (PRESSURE DROPS IN FLOWS THROUGH T-SHAPED PIPE FITTING)", BULLETIN TECHN. DE LA SUISSE ROMANDE, VOL. 83, NO. 9, PP. 123-130, NO. 10, PP. 143-148, 1957. (FRENCH)
- GIESECKE, F.E. FRICTION OF WATER IN PIPES AND FITTINGS, BULLETIN NO. 1759, UNIVERSITY OF TEXAS, 1917.
- GIESECKE, F.E., AND W.H. BADGETT. "LOSS OF HEAD IN COPPER PIPE FITTINGS", HEATING, PIPING, AND AIR CONDITIONING, JUNE, 1932.

- GILMAN, S.F., AND N.Y. SYRACUSE, "PRESSURE LOSSES OF DIVIDED FLOW FITTINGS", HEATING PIPING AIR-CONDITIONING, APRIL, 1955, PP. 141-147.
- \*\*HAGER, W.H. "AN APPROXIMATE TREATMENT OF FLOW IN BRANCHES AND BENDS", PROCEEDINGS OF THE INSTITUTION OF MECHANICAL ENGINEERS, VOL. 1980, NO. 4, 1984, PP. 63-69.
- HOOPES, J.W., S.E. ISAKOFF, AND ET. AL. "FRICTION LOSSES IN SCREWED IRON TEES", CHEMICAL ENGINEERING PROGRESS, VOL. 44, NO. 9, 1948, PP. 691-696.
- \*\*HOWELL, GLEN W., AND TERRY M. WEATHERS. "3.0 FLUID MECHANICS", AEROSPACE FLUID COMPONENT DESIGNERS' HANDBOOK, RP-TDR-64-25, VOLUME 1, TRW SYSTEMS GROUP, REDONDO BEACH, CALIFORNIA, FEBRUARY, 1970.
- \*\*IDEL'CHIK, I.E. HANDBOOK OF HYDRAULIC RESISTANCE, (COEFFICIENTS OF LOCAL RESISTANCE AND OF FRICTION), AEC-TR-6630, (GOSUDARSTVENNOE ENERGETICHESKOE IZDATEL'STVO, MOSKVA-LENINGRAD), 1960.
- \*INGARD, U. "FLOW EXCITATION AND COUPLING OF ACOUSTIC MODES OF A SIDE BRANCH CAVITY IN A DUCT", JOURNAL OF THE ACOUSTIC SOCIETY OF AMERICA, VOL. 60, NO. 5, NOVEMBER, 1976, PP. 1213-1215.
- KAMINSKI, D.A., EDITOR. FLUID FLOW DATA BOOK, GENERAL ELECTRIC COMPANY, SCHENECTADY, NEW YORK.
- KELLER, J.D. "THE MANIFOLD PROBLEM", JOURNAL OF APPLIED MECHANICS, VOL. 16, NO. 1, 1948, PP. 77-85.
- KINNE, E. "CONTRIBUTION TO THE KNOWLEDGE OF HYDRAULIC LOSSES IN BRANCHES", PROCEEDINGS OF THE HYDRAULIC INSTITUTE TECHNICAL HOCHSCHULE, MUNCHEN, VOL. 4, 1931, PP. 70-93. (TRANSLATION IN ABSTRACT FORM, ENGINEERING NEWS RECORD, VOL. 108, 1932, P. 684.
- MATTHEW, G.D. "SIMPLE APPROXIMATE TREATMENT OF CERTAIN INCOMPRESSIBLE DUCT FLOW PROBLEMS INVOLVING SEPARATION", JOURNAL OF MECHANICAL ENGINEERING SCIENCE, VOL. 17, NO. 2, 1975, PP. 57-64.
- MCKOWN, J.S. "MECHANICS OF MANIFOLD FLOW", PAPER NO. 2714, TRANSACTIONS OF THE AMERICAN SOCIETY OF CIVIL ENGINEERS, VOL. 119, 1954, PP. 1103-1142.
- MILLER, DONALD S. INTERNAL FLOW - A GUIDE TO LOSSES IN PIPE AND DUCT SYSTEMS, BRITISH HYDROMECHANICS RESEARCH ASSOCIATION, CRANFIELD, U.K., 1971.
- \*\*MILLER, DONALD S. INTERNAL FLOW SYSTEMS, BHRA FLUID ENGINEERING SERIES, VOLUME 5, BRITISH HYDROMECHANICS RESEARCH ASSOCIATION, BHRA FLUID ENGINEERING, ENGLAND, 1978.
- MILLER, L.G., C.H. PESTERFIELD, AND R.J. WAALKES. "RESISTANCE OF RECTANGULAR DIVIDED-FLOW FITTINGS", HEATING PIPING AIR-CONDITIONING, JANUARY, 1956, PP. 195-200.
- MULLER, W., AND H. STRATMANN. "PRESSURE LOSSES IN BRANCH PIPES AND DISTRIBUTORS", SULZER TECHNICAL REVUE, NO. 4, 1971 PP. 280-298.

- PETERMANN, F. "LOSS IN OBLIQUE-ANGLED PIPE BRANCHES", TRANS. HYDRAULIC INST. TECH. HOCHSCHULE, MUNCHEN, 1929. TRANSLATION IN AM. MECH. ENGRS. BULL. 3, PP. 65-77, 1935.
- RUUS, E. "HEAD LOSSES IN WYES AND MANIFOLDS", PROCEEDINGS OF THE AMERICAN SOCIETY OF CIVIL ENGINEERS, JOURNAL OF HYDRAULICS DIVISION, VOL. 96, NO. HY3, 1970, PP. 593-600.
- SALVESEN, F. HYDRAULIC LOSSES IN BRANCHPIPES, REPORT VL 121, TECHNICAL UNIVERSITY OF NORWAY, 1961-62.
- STEWART, L.J., " FLOW LOSSES IN RECTANGULAR DIVIDED FLOW DUCTWORK FITTINGS", REPORT 41, HEATING AND VENTILATION RESEARCH ASSOCIATION LABORATORY, NOVEMBER, 1968.
- \*\*VAZSONYI, ANDREW. "PRESSURE LOSS IN ELBOWS AND DUCT BRANCHES", TRANS. ASME, VOL. 66, NO. 1, APRIL, 1944, PP. 177-182.
- VERBAAN, B. FLOW AND PRESSURE DISTRIBUTIONS FOR TURBULENT FLOW THROUGH DIVIDING OR COMBINING MANIFOLDS, M. SC. THESIS, UNIVERSITY WITWATERSRAND, 1971.
- VOGEL, G. "EXPERIMENTS TO DETERMINE THE LOSS AT RIGHT-ANGLED PIPE TEES", THE HYDRAULIC LABRATORY PRACTICE, (ED. J.R. FREEMAN) ASME, NEW YORK, 1929, PP. 470-472.
- WALTER, R.F., ET. AL. "MODEL STUDIES OF PENSTOCKS AND OUTLET WORKS", U.S. DEPT. INTERIOR, BUREAU OF RECLAMATION, BOULDER CANYON PROJECT FINAL REPORTS, PART VI- HYDRAULIC INVESTIGATIONS, BULLETIN 2, 1938.
- \*\*WARD-SMITH, A.J. INTERNAL FLUID FLOW, THE FLUID DYNAMICS OF FLOW IN PIPES AND DUCTS, CLARENDON PRESS, OXFORD, GREAT BRITAIN, 1980.
- WILLIAMSON, J.V., AND T.J. RHONE. "DIVIDING FLOW IN BRANCHES AND WYES", JOURNAL OF HYDRAULICS DIVISION, PROCEEDINGS OF THE ASCE, VOL. 99, NO. HY5, 1973, PP. 747-769.
- TOTAL NUMBER OF REFERENCES FOR BRANCHES - DIVIDING/COMBINING = 39

SUDDEN AREA CHANGES

- \*\*"AIR DUCT DESIGN", CHAPT. 31, ASHRAE 1977 FUNDAMENTALS HANDBOOK.  
AMERICAN SOCIETY OF HEATING, REFRIGERATION, AND AIR CONDITIONING  
ENGINEERS, 1977, PP. 31.25-31.36.
- COMPRESSIBLE FLOW OF GASES. PRESSURE LOSSES AND DISCHARGE COEFFICIENTS  
OF ORIFICE PLATES, PERFORATED PLATES AND THICK ORIFICE PLATES IN  
DUCTS; ITEM NO. 82009; VOL. 3A, DUCT FITTINGS AND EQUIPMENT, FLUID  
MECHANICS, INTERNAL FLOW; ENGINEERING SCIENCES DATA UNIT, LONDON,  
ENGLAND, APRIL, 1982.
- \*\*FLOW OF FLUIDS THROUGH VALVES, FITTINGS, AND PIPE, TECHNICAL PAPER NO  
410, CRANE CO., CHICAGO, ILLINOIS, 1969.
- FLOW OF LIQUIDS. PRESSURE LOSSES ACROSS ORIFICE PLATES, PERFORATED  
PLATES AND THICK ORIFICE PLATES IN DUCTS; ITEM NO. 81029; VOL. 3A,  
DUCT FITTINGS AND EQUIPMENT, FLUID MECHANICS, INTERNAL FLOW,  
ENGINEERING SCIENCES DATA UNIT, LONDON, ENGLAND, SEPTEMBER, 1981.
- FLOW THROUGH A SUDDEN ENLARGEMENT OF AREA IN A DUCT; ITEM NO. 72011,  
VOL. 4, DUCT EXPANSIONS, DUCT CONTRACTIONS, FLUID MECHANICS,  
INTERNAL FLOW; ENGINEERING SCIENCES DATA UNIT, LONDON, ENGLAND,  
APRIL, 1972.
- \*\*"FLUID DYNAMICS", SECTION 3, PROPULSION MANUAL-FUNDAMENTAL  
INFORMATION, VOLUME III, THE MARTIN COMPANY, JANUARY 27, 1958.
- PRESSURE LOSSES IN FLOW THROUGH A SUDDEN CONTRACTION OF DUCT AREA;  
ITEM NO. 78007; VOL. 4, DUCT EXPANSIONS, DUCT CONTRACTIONS, FLUID  
MECHANICS, INTERNAL FLOW; ENGINEERING SCIENCES DATA UNIT, LONDON,  
ENGLAND, APRIL, 1981.
- SAE AEROSPACE APPLIED THERMODYNAMICS MANUAL, SAE COMMITTEE A-9, AERO  
SPACE ENVIRONMENTAL CONTROL SYSTEMS, TECHNICAL DIVISION, SOCIETY OF  
AUTOMOTIVE ENGINEERS, NEW YORK, JANUARY, 1962.
- ABBOTT, D.E., AND S.J. KLINE. "EXPERIMENTAL INVESTIGATION OF SUBSONIC  
TURBULENT FLOW OVER SINGLE AND DOUBLE BACKWARD FACING STEPS",  
JOURNAL OF BASIC ENGINEERING, TRANS. ASME, SERIES D, SEPTEMBER,  
1962, P. 317.
- ARCHER, W.H. "EXPERIMENTAL DETERMINATION OF LOSS OF HEAD DUE TO SUDDEN  
ENLARGEMENT IN CIRCULAR PIPES", TRANSACTIONS OF THE AMERICAN  
SOCIETY OF CIVIL ENGINEERS, VOL. 76, 1913, P. 999.
- ASTARITA, G., AND G. GREGO. "EXCESS PRESSURE DROP IN LAMINAR FLOW  
THROUGH SUDDEN CONTRACTION", INDUSTRIAL ENGINEERING CHEMICAL  
FUNDAMENTALS, VOL. 7, NO. 1, FEBRUARY, 1968, PP. 27-31.
- BECK, C. "LAMINAR FLOW FRICTION LOSSES THROUGH FITTINGS, BENDS, AND  
VALVES", JOURNAL OF THE AMERICAN SOCIETY OF NAVAL ENGINEERS,  
VOL. 56, NO. 2, MAY, 1944, PP. 235-271.
- BENEDICT, R.P., AND N.A. CARLUCCI. HANDBOOK OF SPECIFIC LOSSES IN  
FLOW SYSTEMS, PLENUM PRESS, NEW YORK, 1966.
- \*\*BENEDICT, R.P., N.A. CARLUCCI, AND S.D. SWETZ. "FLOW LOSSES IN ABRUPT  
ENLARGEMENTS AND CONTRACTIONS", JOURNAL OF ENGINEERING FOR POWER,  
TRANS. ASME, SERIES A, VOL. 88, JANUARY, 1966, PP. 77-81.

- BENEDICT, R. P., J. S. MYLER, J. A. DUDLEY, AND A. F. GIBB. "LAMINAR FLOW ACROSS AN ABRUPT ENLARGEMENT", PAPER NO. 77-WA-TH-1, ASME WINTER ANNUAL MEETING, HOUSTON, TEXAS, NOVEMBER 16-DECEMBER 1, 1975.
- BONNINGTON, S. T. "MEASUREMENTS OF THE PRESSURE LOSS IN COFFER FITTINGS", BHRA REPORT RR719, BRITISH HYDROMECHANICAL RESEARCH ASSOCIATION CRANFIELD, U. K., 1961.
- CHRISTIANSEN, E. B., S. J. PELSEY, AND T. R. CARTER. "LAMINAR FLOW THROUGH AN ABRUPT CONTRACTION", INSTITUTION OF MECHANICAL ENGINEERS JOURNAL, VOL. 161, NO. 21, MARCH 1972, PP. 177-181.
- COLE, R. N., AND B. MILLS. "THEORY OF SUDDEN ENLARGEMENT APPLIED TO THE POPPET EXHAUST VALVE, WITH SPECIAL REFERENCE TO EXHAUST FLOW SCAVENGING", PROCEEDINGS OF THE INSTITUTION OF MECHANICAL ENGINEERS, VOL. 161, NO. 8, 1951, PP. 364-378.
- COUSINS, T. "THE PERFORMANCE OF LONG BORE GAUGES AT LOW REYNOLDS NUMBERS", MODERN DEVELOPMENTS IN FLOW MEASUREMENT, PROCEEDINGS OF THE INTERNATIONAL CONFERENCE, HARWELL, BERKSHIRE, ENGLAND, SEPTEMBER 21-23, 1971, LONDON, PETER PERNER, LTD., 1972, PP. 160-174.
- DAILEY, GEORGE F., AND G. E. GEIGER. "ANALYSIS OF FLOW SEPARATION IN AN ANNULAR EXPANSION CONTRACTION WITH INNER CYLINDER ROTATION", PAPER NO. 77-SE-7, JOURNAL OF FLUIDS ENGINEERING, TRANS. ASME, SERIES D, JANUARY, 1975.
- DECKER, E. E. L., AND Y. F. CHANG. "AN INVESTIGATION OF STEADY COMPRESSIBLE FLOW THROUGH THICK ORIFICES", PAPER 71, PROCEEDINGS OF THE INSTITUTION OF MECHANICAL ENGINEERS, VOL. 180, PART 3D, 1965-1966, PP. 31-323.
- DECKER, E. E. L. "COMPRESSIBLE FLOW THROUGH SQUARE EDGE RECTANGULAR ORIFICES", PROCEEDINGS OF THE INSTITUTION OF MECHANICAL ENGINEERS, VOL. 192, SEPTEMBER, 1976, PP. 277-286.
- DEIGSLER, ROBERT G. "ANALYSIS OF TURBULENT HEAT TRANSFER AND FLOW IN THE ENTRANCE REGIONS OF SMOOTH PASSAGES", NACA TN 3016, 1953, (DDA 53-15181).
- DITTRICH, RALPH T., AND CHARLES GRAVES. "DISCHARGE COEFFICIENTS FOR COMBUSTOR LINER AIR-ENTRY HOLES. I. CIRCULAR HOLES WITH PARALLEL FLOW", NACA TN 3663, LEWIS FLIGHT PROPULSION LABORATORY, CLEVELAND, OHIO, APRIL, 1956.
- DITTRICH, RALPH T. "DISCHARGE COEFFICIENTS FOR COMBUSTOR LINER AIR-ENTRY HOLES. II. FLUSH RECTANGULAR HOLES, STEP LOUVERS, AND SCOOPS", NACA TN 3924, LEWIS FLIGHT PROPULSION LABORATORY, CLEVELAND, OHIO, APRIL, 1958.
- DODGE, LOUIS. "FLUID THROTTLING DEVICES", FLOW RESISTANCE IN PIPING AND COMPONENTS, PRODUCT ENGINEERING, REPRINT R109, MCGRAW-HILL, NEW YORK, NEW YORK, MARCH 30, 1964, PP. 14-20.

- DUGGINS, R.F., A. LICHTAROWICZ, AND E. MARKLAND. "DISCHARGE COEFFICIENTS FOR INCOMPRESSIBLE NONCAVITATING FLOW THROUGH LONG ORIFICES". JOURNAL OF MECHANICAL ENGINEERING SCIENCE, VOL. 7, JUNE, 1965, PP. 210-219.
- \*FLEMING, DAVID P., AND E.M. SPARROW. "FLOW IN THE HYDRODYNAMIC ENTRANCE REGION OF DUCTS OF ARBITRARY CROSS-SECTION". JOURNAL OF HEAT TRANSFER, TRANS. ASME, VOL. 91, NO. 3, AUGUST, 1969, PP. 345-354.
- HALPENNY, P.F., H.B. NOTTAGE, AND P.S. STARRETT. SURVEY OF INFORMATION CONCERNING THE EFFECTS OF NONSTANDARD APPROACH CONDITIONS UPON ORIFICE AND VENTURI METERS, ASME, WINTER ANNUAL MEETING, CHICAGO, ILLINOIS, NOVEMBER 7-11, 1965, PAPER 65-WA/FM-5
- \*\*HALL, H.B., AND E.M. ORME. "FLOW OF A COMPRESSIBLE FLUID THROUGH A SUDDEN ENLARGEMENT IN A PIPE". PROCEEDINGS OF THE INSTITUTION OF MECHANICAL ENGINEERS, VOL. 169, NO. 49, 1955, PP. 1007-1015. (DISCUSSION: PP. 1016-1020.)
- HEAD, J.F. IMPROVED EXPANSION FACTORS FOR NOZZLES, ORIFICES, AND VARIABLE-AREA METERS, ASME, WINTER ANNUAL MEETING, DETROIT, MICHIGAN, NOVEMBER 11-15, 1973.
- HENDRICKS, R.C., AND N.P. POOLOS. CRITICAL MASS FLUX THROUGH SHORT BORDA TYPE INLETS OF VARIOUS CROSS SECTIONS, PAPER B1-77, XV CONGRESS OF REFRIGERATION, VENICE, ITALY, SEPTEMBER 23-29, 1979
- HENDRICKS, R.C. SOME ASPECTS OF A FREE JET PHENOMENA TO 105 L/D IN A CONSTANT AREA DUCT, PAPER B1-78, XV CONGRESS OF REFRIGERATION, VENICE, ITALY, SEPTEMBER 23-29, 1979.
- HENDRICKS, R.C. A FREE JET PHENOMENA IN A 90 DEGREE - SHARP EDGE INLET GEOMETRY, PAPER SUBMITTED TO CRYOGENIC ENGINEERING CONFERENCE, UNIVERSITY OF WISCONSIN, MADISON, AUGUST 21-24, 1979.
- \*\*HENRY, JOHN R. DESIGN OF POWER-PLANT INSTALLATIONS. PRESSURE-LOSS CHARACTERISTICS OF DUCT COMPONENTS, NACA WR L-208, (FORMERLY NACA ARR L4F26), 1944.
- HOLGER, D.K., T.A. WILSON, AND G.S. BEAVERS. "THE INERTANCE OF A SMOOTH-EDGED ORIFICE", ACOUSTICAL SOCIETY OF AMERICA, JOURNAL, VOL. 51, APRIL, 1972, PART 1, PP. 1156-1163. DECEMBER 10, 1948, PP. 587-589.
- \*\*HOWELL, GLEN W., AND TERRY M. WEATHERS. "3-D FLUID MECHANICS". AEROSPACE FLUID COMPONENT DESIGNERS' HANDBOOK, RPL-TDR-64-150, VOLUME 1, TRW SYSTEMS GROUP, REDONDO BEACH, CALIFORNIA, FEBRUARY, 1970.
- HUGHES, H.J., AND A.T. STAFFORD. HYDRAULICS, MC MILLAN & COMPANY, NEW YORK, 1911, P. 330.
- HUNG, T.K. LAMINAR FLOW IN CONDUIT EXPANSIONS, PH.D. DISSERTATION, UNIVERSITY OF IOWA MICROFILMS, IOWA CITY, IOWA, 1964.



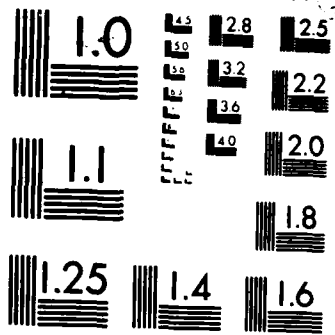

MICROCOPY RESOLUTION TEST CHART  
NATIONAL BUREAU OF STANDARDS 1963-A

- \*\*IDEL'CHIK, I.E. HANDBOOK OF HYDRAULIC RESISTANCE. (COEFFICIENTS OF LOCAL RESISTANCE AND OF FRICTION), AEC-TR-6630, (GOSUDARSTVENNOE ENERGETICHESKOE IZDATEL'STVO, MOSKVA-LENINGRAD), 1960.
- \*\*JERGER, J.J. METHODS FOR ESTIMATING PRESSURE LOSSES IN DUCTS, REPORT R-109, AIRPLANE DIVISION, CURTISS-WRIGHT CORPORATION, ROBERTSON, MISSOURI, FEBRUARY 26, 1942.
- KAMINSKI, D.A., EDITOR. FLUID FLOW DATA BOOK, GENERAL ELECTRIC COMPANY, SCHENECTADY, NEW YORK.
- KAYE, S.E., AND S.L. ROSEN. "THE DEPENDENCE OF LAMINAR ENTRANCE LOSS COEFFICIENTS ON CONTRACTION RATIO FOR NEWTONIAN FLUIDS", AMERICAN INSTITUTION OF CHEMICAL ENGINEERS JOURNAL, VOL. 17, NO. 5, SEPTEMBER, 1970, PP. 1269-1270.
- KAYS, W.M. "LOSS COEFFICIENTS FOR ABRUPT CHANGES IN FLOW CROSS SECTION WITH LOW REYNOLDS NUMBER FLOW IN SINGLE AND MULTIPLE TUBE SYSTEMS", TRANS. ASME, NOVEMBER, 1950, P. 1067.
- \*\*KINDSVATER CARL E. ENERGY LOSSES ASSOCIATED WITH ABRUPT ENLARGEMENTS IN PIPES, GEOLOGICAL SURVEY AND WATER-SUPPLY PAPER 1369-B, U.S. DEPARTMENT OF THE INTERIOR, WASHINGTON, D.C., 1961.
- KITTREDGE, C.P., AND D.S. ROWLEY. "RESISTANCE COEFFICIENTS FOR LAMINAR AND TURBULENT FLOW THROUGH ONE-HALF-INCH VALVES AND FITTINGS", TRANS. ASME, VOL. 79, 1957, PP. 1759-1766.
- KNIGHT, H.A., AND R.B. WALKER. COMPONENT PRESSURE LOSSES IN COMBUSTION CHAMBERS, NGTE REPORT NO. R143, NATIONAL GAS TURBINE ESTABLISHMENT, ENGLAND, NOVEMBER, 1953.
- KRATZ, ALONZO P., AND JULIAN R. FELLOWS. PRESSURE LOSSES RESULTING FROM CHANGES IN CROSS-SECTIONAL AREA IN AIR DUCTS, UNIVERSITY OF ILLINOIS BULLETIN 300, VOL. 35, NO. 52, ENGINEERING EXPERIMENT STATION, UNIVERSITY OF ILLINOIS, URBANA, FEBRUARY 25, 1938.
- \*\*LAKSHMANA RAO, NAGAR S., AND KALAMBUR SRIDHARAN. "ORIFICE LOSSES FOR LAMINAR APPROACH FLOW", JOURNAL OF THE HYDRAULICS DIVISION, PROCEEDINGS OF THE AMERICAN SOCIETY OF CIVIL ENGINEERS, VOL. 98, NO. HY11, NOVEMBER, 1972, PP. 2015-2034.
- \*\*LIPSTEIN, N.J. "LOW VELOCITY SUDDEN EXPANSION PIPE FLOW", ASHRAE JOURNAL, VOL. 4, NO. 7, JULY, 1962, PP. 43-47.
- \*LUNDGREN, T.S., E.M. SPARROW, AND J.B. STAIR. "PRESSURE DROP DUE TO THE ENTRANCE REGION IN DUCTS OF ARBITRARY CROSS-SECTION", JOURNAL OF BASIC ENGINEERING, TRANS. ASME, VOL. 86, NO. 3, SEPTEMBER, 1964, PP. 620-626.
- \*MACAGNO, E.O., AND T. HUNG. "COMPUTATIONAL AND EXPERIMENTAL STUDY OF A CAPTIVE ANNULAR EDDY", JOURNAL OF FLUID MECHANICS, VOL. 28, PART 1, 1967, PP. 43-64.
- MASCHECK, H.J. "PLANE LAMINAR FLOW THROUGH CONTRACTIONS AND ORIFICES AT SMALL REYNOLDS NUMBER", WISSENSCHAFTLICHE ZEITSCHRIFT, VOL 12, NO. 6, 1963, PP. 1833-1836. (GERMAN)

- \*MCADAMS, WILLIAM H. "FLOW OF FLUIDS", CHAPTER 6, HEAT TRANSMISSION, 3RD EDITION, MCGRAW-HILL BOOK CO., NEW YORK, 1954, PP. 140-164.
- \*MCCOMAS, S.T., AND E.R.G. ECKERT. "LAMINAR PRESSURE DROP ASSOCIATED WITH THE CONTINUUM ENTRANCE REGION AND FOR SLIP FLOW IN A CIRCULAR TUBE", JOURNAL OF APPLIED MECHANICS, VOL. 32, NO. 4, DECEMBER, 1965, PP. 765-770.
- METGER, G.W., H.T. RICHARDS, AND J.E. RHODE. DISCHARGE COEFFICIENTS FOR THICK PLATE ORIFICES WITH APPROACH FLOW PERPENDICULAR AND INCLINED TO THE ORIFICE AXIS, NASA, LEWIS RESEARCH CENTER, CLEVELAND, OHIO, NASA-TN-D-5467, OCTOBER, 1967.
- MILLER, DONALD S. INTERNAL FLOW - A GUIDE TO LOSSES IN PIPE AND DUCT SYSTEMS, BRITISH HYDROMECHANICS RESEARCH ASSOCIATION, CRANFIELD, U.K., 1971.
- \*\*MILLER, DONALD S. COMPRESSIBLE INTERNAL FLOW, BHRA FLUID ENGINEERING SERIES, VOLUME 10, BRITISH HYDROMECHANICS RESEARCH ASSOCIATION, BHRA FLUID ENGINEERING, ENGLAND, 1984.
- MILLS, R.D. FLOW IN RECTANGULAR CAVITIES, (PHD DISSERTATION), LONDON UNIVERSITY, 1961.
- \*MILLS, R.D. "ON THE CLOSED MOTION OF A FLUID IN A SQUARE CAVITY", JOURNAL OF THE ROYAL AERONAUTICAL SOCIETY, VOL. 69, FEBRUARY, 1965, PP. 116-120.
- MIYAKE, K., AND KAZUNARI KOMOTORI. ON THE FLOW COEFFICIENT OF AN ANNULAR CONSTRICTION, (UNPUBLISHED).
- O'BRIEN, M.P., AND G.H. HICKOX. APPLIED FLUID MECHANICS, MCGRAW-HILL, NEW YORK, 1937.
- PATTERSON, G.N. "MODERN DIFFUSER DESIGN", AIRCRAFT ENGRNG, VOL. 10, PP. 273, 1938.
- PETERS, H. CONVERSION OF ENERGY IN CROSS-SECTIONAL DIVERGENCE UNDER DIFFERENT CONDITIONS OF INFLOW, NACA TM 737, 1934. (TRANSLATION FROM ING. ARCHIV., VOL. 2, PP. 92-107, 1931.)
- PIGOTT, R.J.S. "PRESSURE LOSSES IN TUBING, PIPE, AND FITTINGS", TRANS. ASME, VOL. 72, 1950, PP. 679-688.
- PIGOTT, R.J.S. "LOSSES IN PIPES AND FITTINGS", TRANS. ASME, VOL. 79, NO. 8, 1957, PP. 1767-1783.
- QUINN, B. "FLOW IN THE ORIFICE OF A RESONANT CAVITY", AIAA, STUDENT JOURNAL, VOL. 1, APRIL, 1963, PP. 1-5.
- RAY, A.K. "ON THE EFFECT OF ORIFICE SIZE ON STATIC PRESSURE READING AT DIFFERENT REYNOLDS NUMBERS", TRANSLATED INTO ENGLISH FROM ING. ARCHIV., AERONAUTICAL RESEARCH COUNCIL, LONDON, ENGLAND, VOL. 24, NO. 3, 1956, PP. 171-181.
- RAYLE, R.E. INFLUENCE OF ORIFICE GEOMETRY ON STATIC PRESSURE MEASUREMENTS, M.I.T., CAMBRIDGE, MASSACHUSETTS, ANNUAL MEETING, ASME, ATLANTIC CITY, NOVEMBER 29-DECEMBER 4, 1959.

- \*ROSHKO, A. SOME MEASUREMENTS OF FLOW IN A RECTANGULAR CUT-OUT,  
NACA TN 3488, 1955. (DDA 67-2471)
- \*\*SCHUTT, H.C. "LOSSES OF PRESSURE HEAD DUE TO SUDDEN ENLARGEMENT OF A  
FLOW CROSS-SECTION", PAPER NO. HYD-51-10, TRANS. ASME, VOL. 51,  
NO. 1, 1929, PP. 83-87.
- SHOUMAN, A.R., AND J.L. MASSEY, JR. STAGNATION PRESSURE LOSSES OF  
COMPRESSIBLE FLUIDS THROUGH ABRUPT AREA CHANGES NEGLECTING FRICTION  
AT THE WALLS, PAPER NO. 68-WA/FE-46, ASME, 1968.
- \*\*SIMPSON, LARRY L. "SIZING PIPING FOR PROCESS PLANTS", CHEMICAL  
ENGINEERING, JUNE 17, 1968, PP. 192-214.
- \*SMYTH, R. "TURBULENT FLOW OVER A PLANE SYMMETRIC SUDDEN EXPANSION",  
JOURNAL OF FLUID ENGINEERING, TRANS. ASME, SERIES I, VOL. 101, NO.  
3, SEPTEMBER, 1979, PP. 348-353.
- \*SQUIRE, H.B. "NOTE ON THE MOTION INSIDE A REGION OF RECIRCULATION  
(CAVITY FLOW)", JOURNAL OF THE ROYAL AERONAUTICAL SOCIETY, VOL. 60,  
MARCH, 1956, PP. 203-205.
- \*\*TYLER, R.A., AND R.G. WILLIAMSON. "SUDDEN AREA ENLARGEMENT PRESSURE  
RECOVERY WITH INFLOW DISTORTION", AERONAUTICAL JOURNAL, VOL. 72,  
NO. 687, MARCH, 1968, PP. 243-244.
- \*\*ULVILA, E.A. "THREE STEPS FOR CALCULATING PRESSURE DROP", HYDRAULICS  
& PNEUMATICS, OCTOBER, 1981, PP. 173-176, 240.
- WARD-SMITH, A.J. SOME ASPECTS OF FLUID FLOW IN DUCTS, (PHD THESIS),  
UNIVERSITY OF OXFORD, UNITED KINGDOM, 1968.  
(PUBLISHED BY BUTTERWORTHS 1971)
- \*\*WARD-SMITH, A.J. PRESSURE LOSSES IN DUCTED FLOWS, BUTTERWORTHS,  
LONDON, ENGLAND, 1971.
- WARD-SMITH, A.J. "CRITICAL FLOWMETERING: THE CHARACTERISTICS OF  
CYLINDRICAL NOZZLES WITH SHARP UPSTREAM EDGES," INTERNATIONAL  
JOURNAL OF HEAT AND FLUID FLOW, VOL. 1, NO. 3, 1979, PP 123-132.
- \*\*WARD-SMITH, A.J. INTERNAL FLUID FLOW, THE FLUID DYNAMICS OF FLOW IN  
PIPES AND DUCTS, CLARENDON PRESS, OXFORD, GREAT BRITAIN, 1980.
- WINKEL, R. "WATER MOTION IN PIPES WITH RING SLOT FLOW CROSS-SECTION",  
Z. ANGEW. MATH. MECH., VOL. 3, 1923, PP. 251-257. (GERMAN)

TOTAL NUMBER OF REFERENCES FOR SUDDEN AREA CHANGES = 82

ORIFICES - STATIC AND ROTATING

- \*\*"AIR DUCT DESIGN", CHAPT. 31, ASHRAE 1977 FUNDAMENTALS HANDBOOK, AMERICAN SOCIETY OF HEATING, REFRIGERATION, AND AIR CONDITIONING ENGINEERS, 1977, PP. 31.25-31.36.
- COMPRESSIBLE FLOW OF GASES. PRESSURE LOSSES AND DISCHARGE COEFFICIENTS OF ORIFICE PLATES, PERFORATED PLATES AND THICK ORIFICE PLATES IN DUCTS; ITEM NO. 82009; VOL. 3A, DUCT FITTINGS AND EQUIPMENT; FLUID MECHANICS, INTERNAL FLOW; ENGINEERING SCIENCES DATA UNIT, LONDON, ENGLAND, APRIL, 1982.
- \*\*FLOW OF FLUIDS THROUGH VALVES, FITTINGS, AND PIPE, TECHNICAL PAPER NO. 410, CRANE CO., CHICAGO, ILLINOIS, 1969.
- FLOW MEASUREMENT WITH STANDARDIZED NOZZLES, ORIFICE PLATES, AND VENTURI TUBES, NATIONAL LENDING LIBRARY, BOSTON SPA, ENGLAND, TRANSLATION INTO ENGLISH OF GERMAN STD., DIN-1952, AUGUST, 1971.
- FLOW OF LIQUIDS, PRESSURE LOSSES ACROSS ORIFICE PLATES, PERFORATED PLATES AND THICK ORIFICE PLATES IN DUCTS; ITEM NO. 81039; VOL. 3A, DUCT FITTINGS AND EQUIPMENT; FLUID MECHANICS, INTERNAL FLOW; ENGINEERING SCIENCES DATA UNIT, LONDON, ENGLAND, SEPTEMBER, 1982.
- \*\*"FLUID DYNAMICS", SECTION 3, PROPULSION MANUAL-FUNDAMENTAL INFORMATION, VOLUME III, THE MARTIN COMPANY, JANUARY 27, 1958.
- FLUID METERS: THEIR THEORY AND APPLICATION. 6TH EDITION, ASME, NEW YORK, 1971.
- INTERNAL FORCED CONVECTIVE HEAT TRANSFER IN COILED PIPES; ITEM NO. 78031; ENGINEERING SCIENCES DATA UNIT, LONDON, ENGLAND, 1978.
- MEASUREMENT OF FLUID AND GAS FLOW BY MEANS OF ORIFICE PLATES IN CLOSED CIRCUITS, NATIONAL LENDING LIBRARY, BOSTON SPA, ENGLAND, TRANSLATION INTO ENGLISH OF NETH. STD., NEN-3004, MAY, 1967.
- MEASUREMENT OF FLUID FLOW BY MEANS OF ORIFICE PLATES, NOZZLES, AND VENTURI TUBES INSERTED IN CIRCULAR CROSS-SECTIONAL CONDUITS RUNNING FULL, ISO DRAFT INTERNATIONAL STANDARD 5167, APRIL, 1976.
- \*\*PRESSURE LOSS AND FLOW CHARACTERISTICS OF VARIOUS AIR PASSAGE CONFIGURATIONS - GENERAL DESIGN DATA, TECHNICAL DESIGN REPORT NO. G.20, ROLLS-ROYCE LIMITED, DERBY, ENGLAND, 1962.
- \*\*"PRESSURE LOSSES OF VENTILATION FITTINGS", SECTION DDS3801-2, CODE 415, DESIGN DATA SHEET, DEPARTMENT OF THE NAVY, BUREAU OF SHIPS, WASHINGTON, D.C., 22 JULY 1950.
- PRESSURE LOSSES ACROSS PERFORATED PLATES, ORIFICE PLATES AND CYLINDRICAL TUBE ORIFICES IN DUCTS; ITEM NO. 72010; ENGINEERING SCIENCES DATA UNIT, LONDON, ENGLAND, APRIL, 1972.
- SAE AEROSPACE APPLIED THERMODYNAMICS MANUAL, SAE COMMITTEE A-9, AEROSPACE ENVIRONMENTAL CONTROL SYSTEMS, TECHNICAL DIVISION, SOCIETY OF AUTOMOTIVE ENGINEERS, NEW YORK, JANUARY, 1962.
- AGAR, J.D. PRESSURE DROP CHARACTERISTICS OF TWO ECCENTRICALLY POSITIONED ORIFICES IN SERIES, M.S. THESIS, WASHINGTON UNIVERSITY, SEATTLE, WASHINGTON, 1965.

- ALDER, G.M. "THE NUMERICAL SOLUTION OF CHOKED AND SUPERCRITICAL IDEAL GAS FLOW THROUGH THICK ORIFICES AND CONVERGENT CONICAL NOZZLES", JOURNAL OF MECHANICAL ENGINEERING SCIENCE, VOL. 21, NO. 3, 1979, PP. 197-203.
- ALVI, S.H., K. SRIDHARAN, AND N.S. LAKSHMANA RAO. "LOSS CHARACTERISTICS OF ORIFICES AND NOZZLES", JOURNAL OF FLUIDS ENGINEERING, ASME, VOL. 100, 1978, PP 299-306.
- ANDERSON, R.E., AND P.A. GRAHAM. A STUDY OF THE EFFECTS OF AN ORIFICE INLET ON THE PERFORMANCE OF A STRAIGHT CYLINDRICAL DIFFUSER, NAVAL AIR PROPULSION TEST CENTER, TRENTON, NEW JERSEY, DECEMBER, 1967.
- BAKER, J.M., R.W. GLASCOV, AND W.P. WALTERS. GENERALIZED GASEOUS DISCHARGE CHARACTERISTICS OF FLAT PLATE ORIFICES--FINAL REPORT, NORTRONICS, HUNTSVILLE, ALABAMA, NASA-CR-98482, NOVEMBER, 1968.
- \*\*BEAN, H.S., E. BUCKINGHAM, AND P.S. MURPHY. "DISCHARGE COEFFICIENTS OF SQUARE-EDGED ORIFICES FOR MEASURING THE FLOW OF AIR", BUREAU OF STANDARDS JOURNAL OF RESEARCH, VOL. 2, MARCH, 1929, PP. 561-658.
- BEAN, H.S. FORMULATION OF EQUATIONS FOR ORIFICE COEFFICIENTS, ASME, WINTER ANNUAL MEETING, NEW YORK, NEW YORK, NOVEMBER 29-DECEMBER 3, 1970.
- BECKER, ERNST. "FLOW PROCESSES IN RING SHAPED SLOTS AND RELATIONSHIP TO THE POISEUILLE LAW", VDI-INVSTIGATION, VOL. 48, VDI-VERLAG, BERLIN, 1907, PP 1-42. (GERMAN)
- \*\*BECKER, ERNST. "FLOW PROCESSES IN ANNULAR GAPS (LABYRINTH SEALS)", (AEC-TR-4960 NTC), ZEITSCHRIFT VDI, VOL. 51, NO. 29, JULY 20, 1907, PP. 1133-1141. (DDA 80-974)
- BEGG, R.D. THE EFFECT OF DOWNSTREAM PRESSURE ASYMMETRY ON THE FLOW FROM TWO-DIMENSIONAL ORIFICES, INTERNATIONAL FEDERATION OF AUTOMATIC CONTROL, SYMPOSIUM ON FLUIDICS, PROCEEDINGS, LONDON, ENGLAND, NOVEMBER 4-8, 1968.
- \*\*BEITLER, S.R., AND D.J. MASON. "CALIBRATION OF ECCENTRIC AND SEGMENTAL ORIFICES IN 4 AND 6-IN. PIPE LINES", TRANS. ASME, OCTOBER, 1949, PP. 751-756.
- \*\*BELL, K.J., AND O.P. BERGELIN. "FLOW THROUGH ANNULAR ORIFICES", TRANS ASME, VOL. 79, NO. 3, APRIL, 1957, PP. 593-601.
- BELL, K.J. ANNULAR ORIFICE COEFFICIENTS WITH APPLICATION TO HEAT EXCHANGER DESIGN, (PHD THESIS), DEPARTMENT OF CHEMICAL ENGINEERING, UNIVERSITY OF DELAWARE, NEWARK, DELAWARE, 1955.
- BELL, K.J. "EXCHANGER DESIGN", PETROLEUM ENGINEER, VOL. 32, NO. 11, OCTOBER, 1960, PP. C26-C40C.
- BENEDICT, R.P., AND N.A. CARLUCCI. HANDBOOK OF SPECIFIC LOSSES IN FLOW SYSTEMS, PLENUM PRESS, NEW YORK, 1966.
- BENEDICT, R.P. GENERALIZED EXPANSION FACTOR OF AN ORIFICE FOR SUBSONIC AND SUPERCRITICAL FLOWS, ASME, WINTER ANNUAL MEETING, NEW YORK, NEW YORK, NOVEMBER 29-DECEMBER 3, 1970.

- \*\*BENSON, R.S., AND D.E. POOL. "THE COMPRESSIBLE FLOW DISCHARGE COEFFICIENTS FOR A TWO-DIMENSIONAL SLIT", INTERNATIONAL JOURNAL OF MECHANICAL SCIENCE, VOL. 7, PERGAMON PRESS, GREAT BRITAIN, PP. 337-353.
- BENSON, R.S., AND H.M.F. EL SHAFIE. "NON-STEADY FLOW THROUGH A SQUARE-EDGED ORIFICE IN A PIPE", JOURNAL OF MECHANICAL ENGINEERING SCIENCE, VOL. 7, DECEMBER, 1965, PP. 482-495.
- BLOOM, G. "THEY WORK EVEN AT LOW FLOW--ERRORLESS ORIFICES", PRODUCT ENGINEERING, VOL. 36, OCTOBER 25, 1965, PP. 61-64.
- \*BRAGG, S.L. "EFFECT OF COMPRESSIBILITY ON THE DISCHARGE COEFFICIENT OF ORIFICES AND CONVERGENT NOZZLES", JOURNAL OF MECHANICAL ENGINEERING SCIENCE, VOL. 2, NO. 1, 1960, PP. 35-44.
- BRAGG, S.L. "EFFECT OF COMPRESSIBILITY ON THE DISCHARGE COEFFICIENT OF ORIFICES AND CONVERGENT NOZZLES", CONSTRUCTION, VOL. 12, NO. 11, 1960, P. 517.
- BURGERS, J.M. FLOW OF AIR THROUGH NARROW SLOTS, (INTERNAL COMMUNICATION) LABORATORY FOR COMBUSTION MOTORS, TH DELFT. (GERMAN)
- CALLAGHAN, E.E., AND D.T. BOWDEN. INVESTIGATION OF FLOW COEFFICIENT OF CIRCULAR, SQUARE, AND ELLIPTICAL ORIFICES AT HIGH PRESSURE RATIOS, NACA TN 1947, 1949.
- CARLEN, C.D. AN EXPERIMENTAL INVESTIGATION OF FLUID FLOW THROUGH SQUARE EDGED ORIFICES LOCATED IN A ROTATING DISK, M.S. THESIS, AIR FORCE INSTITUTE OF TECHNOLOGY, WRIGHT-PATTERSON AIR FORCE BASE, OHIO, MARCH, 1965.
- \*\*CATHERMAN, E.B. SIMPLIFICATION OF FLUID-FLOW COMPUTATIONS FOR ORIFICE METERS, M.S. THESIS, TEXAS TECHNOLOGICAL COLLEGE, LUBBOCK, TEXAS, MAY, 1965.
- CHEN, Y.L., AND R.B. DOWDELL. A STATISTICAL APPROACH TO THE PREDICTION OF DISCHARGE COEFFICIENTS FOR CONCENTRIC ORIFICE PLATES, ASME, WINTER ANNUAL MEETING, LOS ANGELES, CALIFORNIA, NOVEMBER 16-20, 1969.
- CHERVINSKY, A., AND N. CHIGIER. EXPERIMENTAL AND THEORETICAL STUDY OF TURBULENT SWIRLING JETS ISSUING FROM A ROUND ORIFICE, ISRAEL INSTITUTE OF TECHNOLOGY, DEPARTMENT OF AERONAUTICAL ENGINEERING, NOVEMBER, 1965.
- COLE, B.N., AND B. MILLS. "THEORY OF SUDDEN ENLARGEMENTS APPLIED TO THE POPPET EXHAUST-VALVE, WITH SPECIAL REFERENCE TO EXHAUST-PULSE SCAVENGING", PROCEEDINGS OF THE INSTITUTION OF MECHANICAL ENGINEERS, VOL. 1B, NO. 8, 1952-53, PP. 364-378.
- CORAZZI, R., AND T.A. CYGNAROWICZ. THE USE OF SUBSONIC ORIFICES FOR MEASUREMENT OF GAS FLOW, NASA, GODDARD SPACE FLIGHT CENTER, GREENBELT, MARYLAND, NASA-TM-X-63678, SEPTEMBER, 1969.

- COUSINS, T. "THE PERFORMANCE OF LONG BORE ORIFICES AT LOW REYNOLDS NUMBER", MODERN DEVELOPMENTS IN FLOW MEASUREMENT, PROCEEDINGS OF THE INTERNATIONAL CONFERENCE, HARWELL, BERKS., ENGLAND, SEPTEMBER 21-23, 1971, LONDON, PETER PEREGRENUS, LTD., 1972, PP. 160-179.
- \*CUNNINGHAM, R.G. "ORIFICE METERS WITH SUPERCRITICAL COMPRESSIBLE FLOW", TRANS. ASME, JULY, 1951, PP. 625-638.
- DAVIS, E.S. "HEAT TRANSFER AND PRESSURE DROP IN ANNULI", TRANS. ASME, VOL. 65, 1943, PP. 755-760.
- \*\*DAVIS, R.W., AND G.E. MATTINGLY. "NUMERICAL MODELING OF TURBULENT FLOW THROUGH THIN ORIFICE PLATES", NATIONAL BUREAU OF STANDARDS SPECIAL PUBLICATION 484, PROCEEDINGS OF THE SYMPOSIUM ON FLOW IN OPEN CHANNELS AND CLOSED CONDUITS, VOL. 2, NBS, GAITHERSBURG, MARYLAND, FEBRUARY, 23-25, 1977, PP. 491-522.
- \*\*DECKKER, B.E.L., AND Y.F. CHANG. "AN INVESTIGATION OF STEADY COMPRESSIBLE FLOW THROUGH THICK ORIFICES", PAPER 7, PROCEEDINGS OF THE INSTITUTION OF MECHANICAL ENGINEERS, VOL. 180, PART 3J, 1965-1966, PP. 312-323.
- \*\*DECKKER, B.E.L. "COMPRESSIBLE FLOW THROUGH SQUARE EDGE RECTANGULAR ORIFICES", PROCEEDINGS OF THE INSTITUTION OF MECHANICAL ENGINEERS, VOL. 192, SEPTEMBER, 1978, PP. 277-288.
- DICKERSON, P., AND W. RICE. "AN INVESTIGATION OF VERY SMALL DIAMETER LAMINAR FLOW ORIFICES", JOURNAL OF BASIC ENGINEERING, TRANS. ASME, SERIES D, VOL. 91, PP. 546-548.
- DITTRICH, RALPH T., AND CHARLES GRAVES. DISCHARGE COEFFICIENTS FOR COMBUSTOR LINER AIR-ENTRY HOLES. I. CIRCULAR HOLES WITH PARALLEL FLOW, NACA TN 3663, LEWIS FLIGHT PROPULSION LABORATORY, CLEVELAND, OHIO, APRIL, 1956.
- DITTRICH, RALPH T. DISCHARGE COEFFICIENTS FOR COMBUSTOR LINER AIR-ENTRY HOLES. II. FLUSH RECTANGULAR HOLES, STEP LOUVERS, AND SCOOPS, NACA TN 3924, LEWIS FLIGHT PROPULSION LABORATORY, CLEVELAND, OHIO, APRIL, 1958.
- \*\*DODGE, LOUIS. "FLUID THROTTLING DEVICES", FLOW RESISTANCE IN PIPING AND COMPONENTS, PRODUCT ENGINEERING, REPRINT R109, MCGRAW-HILL, NEW YORK, NEW YORK, MARCH 30, 1964, PP. 14-20.
- DUGGINS, R.K., A. LICHTAROWICZ, AND E. MARKLAND. "DISCHARGE COEFFICIENTS FOR INCOMPRESSIBLE NONCAVITATING FLOW THROUGH LONG ORIFICES", JOURNAL OF MECHANICAL ENGINEERING SCIENCE, VOL. 7, JUNE, 1965, PP. 210-219.
- \*\*EGLI, ADOLF. "THE LEAKAGE OF GASES THROUGH NARROW CHANNELS", JOURNAL OF APPLIED MECHANICS, TRANS. ASME, VOL. 59, 1937, PP. 63-67. (DISCUSSION: JOURNAL OF APPLIED MECHANICS, TRANS. ASME, 1938, PP. 36-37.)
- EHRHARDT, G. "ELIMINATION OF THE INFLUENCE OF INSTALLATION DISTURBANCE ON FLOW MEASUREMENTS WITH ORIFICE PLATES", NATIONAL LENDING LIBRARY, BOSTON SPA, ENGLAND, BRENNSTAFF-WAERME-KRAFT, VOL. 24, NO. 12, 1972, PP. 449-452.

- ENGEL, F.V.A., AND W. STAINSBY. "DISCHARGE COEFFICIENT CHARACTERISTICS OF ORIFICES", THE ENGINEER, VOL. 218, JULY 31, 1964, PP. 161-168.
- GHAZI, H.S. A PRESSURE INDEX FOR PREDICTING THE EFFECT OF FLOW PROFILES ON ORIFICE METER PERFORMANCE, ASME, WINTER ANNUAL MEETING, CHICAGO, ILLINOIS, NOVEMBER 7-11, 1965, PAPER 65-WA/FM-3.
- GRACE, H.P., AND C.E. LAPPLE. "DISCHARGE COEFFICIENTS OF SMALL DIAMETER ORIFICES AND FLOW NOZZLES," TRANSACTIONS OF THE AMERICAN SOCIETY OF MECHANICAL ENGINEERS, VOL. 73, NO. 5, 1951, PP 639-647.
- GREENSPAN, D. "NUMERICAL STUDIES OF VISCOUS, INCOMPRESSIBLE FLOW THROUGH AN ORIFICE FOR ARBITRARY REYNOLDS NUMBER", INTERNATIONAL JOURNAL FOR NUMERICAL METHODS IN ENGINEERING, VOL. 6, NO. 4, 1973, PP. 489-496.
- GREPPI, M., AND D. ZAMPAGLIONE. "EDDIES DEVELOPMENT DOWNSTREAM OF A PIPE ORIFICE", MECCANICA, VOL. 8, MARCH, 1973, PP. 35-43.
- GRIMSON, J., AND N. HAY. "ERRORS DUE TO PULSATION IN ORIFICE METERS". AERONAUTICAL JOURNAL, VOL. 75, APRIL, 1971, PP. 284-287.
- GROESBECK, W.A., AND F.L. MANNING. "FLOW RATES FOR SHARP-EDGE ORIFICES", MACHINE DESIGN, VOL. 47, JUNE 12, 1975, PP. 122-123.
- GUST, B. ORIFICE METER FOR MEASUREMENT OF GAS FLOW RATES AT HIGH PRESSURE, CALIFORNIA UNIVERSITY, LIVERMORE, LAWRENCE RADIATION LAB, JULY 16, 1958.
- GUST, W.H., AND E. LOUNSBURY. EMPIRICAL EVALUATION OF A HIGH PRESSURE GAS ORIFICE METER FLOW CONSTANT, CALIFORNIA UNIVERSITY, LIVERMORE, LAWRENCE RADIATION LAB, AUGUST 28, 1958.
- HAHNEMANN, H., AND L. EHRET. "FLOW RESISTANCE IN THE STRAIGHT FLAT SLOT WITH CONSIDERATION OF INLET LOSS", GERMAN AERONAUTICS, 1942, PP 186/2/7. (GERMAN)
- HALFPENNY, P.F., H.B. NOTTAGE, AND P.S. STARRETT. SURVEY OF INFORMATION CONCERNING THE EFFECTS OF NONSTANDARD APPROACH CONDITIONS UPON ORIFICE AND VENTURI METERS, ASME, WINTER ANNUAL MEETING, CHICAGO, ILLINOIS, NOVEMBER 7-11, 1965, PAPER 65-WA/FM-5.
- \*\*HALL, G.W. "ANALYTICAL DETERMINATION OF THE DISCHARGE CHARACTERISTICS OF CYLINDRICAL-TUBE ORIFICES", JOURNAL MECHANICAL ENGINEERING SCIENCE, VOL. 5, NO. 1, 1963, PP. 91-97.
- HEAD, V.P. IMPROVED EXPANSION FACTORS FOR NOZZLES, ORIFICES, AND VARIABLE-AREA METERS, ASME, WINTER ANNUAL MEETING, DETROIT, MICHIGAN, NOVEMBER 11-15, 1973.
- HENDRICKS, R.C. A FREE JET PHENOMENA IN A 90 DEGREE - SHARP EDGE INLET GEOMETRY, PAPER SUBMITTED TO CRYOGENIC ENGINEERING CONFERENCE, UNIVERSITY OF WISCONSIN, MADISON, AUGUST 21-24, 1979.
- \*\*HENRY, JOHN R. DESIGN OF POWER-PLANT INSTALLATIONS. PRESSURE-LOSS CHARACTERISTICS OF DUCT COMPONENTS, NACA WR L-208, (FORMERLY NACA ARR L4F26), 1944.

- HIPPENSTEELE, S.A., AND R.P. COCHRAN. EFFECT OF HOLE GEOMETRY AND ELECTRIC-DISCHARGE MACHINING (EDM) ON AIRFLOW RATES THROUGH SMALL-DIAMETER HOLES IN TURBINE BLADE MATERIAL, NASA TP-1716, NOVEMBER, 1980.
- HOCHREUTHER, W. FORCES GENERATED BY AXIAL FLOW THROUGH GAPS, (DISSERTATION), UNIVERSITY OF STUTTGART, 1975. (GERMAN)
- HOLGER, D.K., T.A. WILSON, AND G.S. BEAVERS. "THE INERTANCE OF A SMOOTH-EDGED ORIFICE", ACOUSTICAL SOCIETY OF AMERICA, JOURNAL, VOL. 51, APRIL, 1972, PART 1, PP. 1156-1163.  
DECEMBER 10, 1948, PP. 587-589.
- HOWELL, A.R. "A NOTE ON R. A. E. ANNULAR AIRFLOW ORIFICE", AERONAUTICAL RESEARCH COMMITTEE REPORTS AND MEMORANDA NO. 1934, BRITISH, 1939.
- \*\*HOWELL, GLEN W., AND TERRY M. WEATHERS. "3.0 FLUID MECHANICS", AEROSPACE FLUID COMPONENT DESIGNERS' HANDBOOK, RPL-TDR-64-25, VOLUME 1, TRW SYSTEMS GROUP, REDONDO BEACH, CALIFORNIA, FEBRUARY, 1970.
- HUNT, B.W. "NUMERICAL SOLUTION OF AN INTEGRAL EQUATION FOR FLOW FROM A CIRCULAR ORIFICE", JOURNAL OF FLUID MECHANICS, VOL. 31, JANUARY, 1968, PP. 361-377.
- IANSHIN, B.I. "LEAKAGE OF VISCOUS FLUIDS THROUGH RING-SHAPED AND RECTANGULAR SLOTS", MNTV GIDROMASINOSTROENIE, NO. 5, 1949. (RUSSIAN)
- \*\*IDEL'CHIK, I.E. HANDBOOK OF HYDRAULIC RESISTANCE, (COEFFICIENTS OF LOCAL RESISTANCE AND OF FRICTION), AEC-TR-6630, (GOSUDARSTVENNOE ENERGETICHESKOE IZDATEL'STVO, MOSKVA-LENINGRAD), 1960,
- IMRIE, B.W., D.H. MALE, AND G.H. TRENGROUSE. "COMPARISON OF UNSTEADY FLOW DISCHARGE COEFFICIENTS FOR SHARP-EDGED ORIFICES WITH STEADY FLOW VALUES", JOURNAL OF MECHANICAL ENGINEERING SCIENCE, VOL. 8, SEPTEMBER, 1966, PP. 322-329.
- \*ISHIZAWA, S. "THE AXISYMMETRIC LAMINAR FLOW IN AN ARBITRARILY SHAPED NARROW GAP", BULLETIN OF THE JSME, VOL. 8, NO. 31, 1965, PP. 353-365.
- ITO, J.I. "A GENERAL MODEL DESCRIBING HYDRAULIC FLIP IN SHARP EDGE ORIFICES", AEROJET LIQUID ROCKET CO., SACRAMENTO, CALIFORNIA, IN APL, 7TH ANNUAL JANNAF COMBUST. MEETING, VOL. 1, FEBRUARY, 1971, PP. 417-426.
- JACKSON, R.A. "THE COMPRESSIBLE DISCHARGE OF AIR THROUGH SMALL THICK PLATE ORIFICES", APPLIED SCIENTIFIC RESEARCH, SECTION A, VOL. 13, 1964, PP. 241-248.
- \*\*JOBSON, D.A. "ON THE FLOW OF A COMPRESSIBLE FLUID THROUGH ORIFICES", PROCEEDINGS OF THE INSTITUTION OF MECHANICAL ENGINEERS, VOL. 169, NO. 37, LONDON, 1955, PP. 767-772. (DISCUSSION: PP. 773-776)

- JOHANSEN, F.C. FLOW THROUGH PIPE ORIFICES AT LOW REYNOLDS NUMBERS, ARC R AND M 1252, AERONAUTICS RESEARCH COUNCIL, UNITED KINGDOM, 1929.
- KAMINSKI, D.A., EDITOR. FLUID FLOW DATA BOOK, GENERAL ELECTRIC COMPANY, SCHENECTADY, NEW YORK,
- KARIM, G.A., AND M. RASHIDI. THE MEASUREMENT OF A PULSATING AIR FLOW USING A SHARP-EDGED ORIFICE METER, ASME, WINTER ANNUAL MEETING, NEW YORK, NEW YORK, NOVEMBER 26-30, 1972.
- \*\*KEARTON, W.J., AND T.H. KEH. "LEAKAGE OF AIR THROUGH LABYRINTH GLANDS OF STAGGERED TYPE", PROCEEDINGS OF THE INSTITUTION OF MECHANICAL ENGINEERS, SERIES A, VOL. 166, NO. 2, 1952, PP. 180-188. (DISCUSSION: PP. 189-195.)
- KNIGHT, H.A., AND R.B. WALKER. COMPONENT PRESSURE LOSSES IN COMBUSTION CHAMBERS, NGTE REPORT NO. R143, NATIONAL GAS TURBINE ESTABLISHMENT, ENGLAND, NOVEMBER, 1953.
- KOCH, R., AND K. FEIND. "PRESSURE LOSS AND HEAT TRANSFER IN RING SLOTS", CHEMIE-ING.-TECHN., VOL. 30, NO. 9, 1958, PP. 577-584. (GERMAN)
- LAHEY, R.T., JR. AND B.S. SHIRALKAR. TRANSIENT FLOW MEASUREMENTS WITH SHARP-EDGED ORIFICES, ASME, FLUIDS ENGINEERING CONFERENCE, PITTSBURGH, PENNSYLVANIA, MAY 9-12, 1971.
- \*\*LAKSHMANA RAD, NAGAR S., AND KALAMBUR SRIDHARAN. "ORIFICE LOSSES FOR LAMINAR APPROACH FLOW", JOURNAL OF THE HYDRAULICS DIVISION, PROCEEDINGS OF THE AMERICAN SOCIETY OF CIVIL ENGINEERS, VOL. 98, NO. HY11, NOVEMBER, 1972, PP. 2015-2034.
- LAMB, OWEN P., AND JAMES S. HOLDHUSEN. INVESTIGATION OF AIRCRAFT DUCTING COMPONENTS AT HIGH SUBSONIC SPEEDS, USAF WADC TR 56-187, FLUIDYNE ENGINEERING CORP., SEPTEMBER, 1956.
- \*\*LENKEI, ANDREW. "CLOSE-CLEARANCE ORIFICES", PRODUCT ENGINEERING, VOL. 36, NO. 9, APRIL 26, 1965, PP. 57-61.
- \*\*LICHTAROWICZ, A., R.K. DUGGINS, AND E. MARKLAND. "DISCHARGE COEFFICIENTS FOR INCOMPRESSIBLE NON-CAVITATING FLOW THROUGH LONG ORIFICES", JOURNAL MECHANICAL ENGINEERING SCIENCE, VOL. 7, NO. 2, 1965, PP. 210-219.
- MASCHECK, H.J. "PLANE LAMINAR FLOW THROUGH CONTRACTIONS AND ORIFICES AT SMALL REYNOLDS NUMBER", WISSENSCHAFTLICHE ZEITSCHRIFT, VOL 12, NO. 6, 1963, PP. 1833-1836. (GERMAN)
- MATTINGLEY, G.E., AND R.W. DAVIS. NUMERICAL SOLUTIONS FOR LAMINAR ORIFICE FLOW, PAPER NO. 77-WA/FE-13, ASME, WINTER ANNUAL MEETING, ATLANTA, GEORGIA, 1977.
- MCVEIGH, J.C. "HYSTERESIS IN THE FLOW THROUGH AND ORIFICE", NATURE, VOL. 212, NOVEMBER 26, 1966, P. 918.

- METGER, G.W., H.T. RICHARDS, AND J.E. RHODE. DISCHARGE COEFFICIENTS FOR THICK PLATE ORIFICES WITH APPROACH FLOW PERPENDICULAR AND INCLINED TO THE ORIFICE AXIS, NASA, LEWIS RESEARCH CENTER, CLEVELAND, OHIO, NASA-TN-D-5467, OCTOBER, 1967.
- METGER, G.W., J.E. RHODE, AND H.T. RICHARDS. DISCHARGE COEFFICIENTS FOR THICK-PLATE ORIFICES, LEWIS-11067, APRIL, 1970.
- \*\*MILLER, DONALD S. INTERNAL FLOW SYSTEMS, BHRA FLUID ENGINEERING SERIES, VOLUME 5, BRITISH HYDROMECHANICS RESEARCH ASSOCIATION, BHRA FLUID ENGINEERING, ENGLAND, 1978.
- \*\*MILLER, DONALD S. COMPRESSIBLE INTERNAL FLOW, BHRA FLUID ENGINEERING SERIES, VOLUME 10, BRITISH HYDROMECHANICS RESEARCH ASSOCIATION, BHRA FLUID ENGINEERING, ENGLAND, 1984.
- MILLER, R.W., AND O. KNIESEL. A COMPARISON BETWEEN ORIFICE AND FLOW NOZZLE LABORATORY DATA AND PUBLISHED COEFFICIENTS, JOURNAL OF FLUIDS ENGINEERING, TRANS. ASME, VOL. 96, JUNE, 1974, PP. 139-149.
- MILLS, R.D. "NUMERICAL SOLUTIONS OF VISCOUS FLOW THROUGH A PIPE ORIFICE AT LOW REYNOLDS NUMBERS", JOURNAL OF MECHANICAL ENGINEERING SCIENCE, VOL. 10, APRIL, 1968, PP. 361-377.
- MIYAKE, K., AND KAZUNARI KOMOTORI. ON THE FLOW COEFFICIENT OF AN ANNULAR CONSTRICTION, (UNPUBLISHED).
- \*\*MYERS, PHILLIP E. "SIZING ORIFICES FOR PRESSURE REDUCTION", MACHINE DESIGN, VOL. 47, NO. 19, AUGUST 7, 1975, PP. 84-85.
- \*\*NAGLE, P., AND A. JAUMOTTE. "INFLUENCE OF SINGLE RESISTANCE FEATURES ON THE DISCHARGE COEFFICIENT FOR A STANDARDIZED ORIFICE, NOZZLE OR VENTURI, EXPERIMENTAL STUDY", PROMOCHEMIE ET ETUDES THERMIQUES ET AEROLIQUES, VOL. 9E, NO. 1, JANUARY, 1978, PP. 34-47. (ROLLS-ROYCE TRANSLATION FROM THE FRENCH 1981)
- NOOTBAAR, R.F., AND R.C. KINTNER. "FLUID FRICTION IN ANNULI OF SMALL CLEARANCE", OHIO STATE UNIVERSITY ENGINEERING EXPERIMENT STATION BULLETIN NO. 149, PROCEEDINGS OF THE SECOND MIDWESTERN CONFERENCE ON FLUID MECHANICS, 1952, PP. 185-199.
- OGUCHI, H., S.I. SATO, AND O. INOUE. "EXPERIMENTAL STUDY ON FREE JET EXPANSION FROM DOUBLE CONCENTRIC ORIFICES TO VACUUM", JAPAN SOCIETY FOR AERONAUTICAL AND SPACE SCIENCES, TRANSACTIONS, VOL. 14, NO. 25, 1971, PP. 72-79.
- PAGE, N.W., J. PATTERSON, AND J.B. RITCHIE. "CONTRACTION COEFFICIENTS FOR COMPRESSIBLE FLOW THROUGH AXISYMMETRIC ORIFICES", INTERNATIONAL JOURNAL OF MECHANICAL SCIENCES, VOL. 12, PP. 405-415.
- \*\*PERRY, JR., J.A. "CRITICAL FLOW THROUGH SHARP-EDGED ORIFICES", TRANS. ASME, VOL. 71, OCTOBER, 1949, PP. 757-764.
- PIGOTT, R.J.S. "PRESSURE LOSSES IN TUBING, PIPE, AND FITTINGS", TRANS. ASME, VOL. 72, 1950, PP. 679-688.
- PIGOTT, R.J.S. "LOSSES IN PIPES AND FITTINGS", TRANS. ASME, VOL. 79, NO. 8, 1957, PP. 1767-1783.

- POSEY, J.W., AND K.J. COMPTON. EFFECT OF NONSYMMETRICAL FLOW RESISTANCE UPON ORIFICE IMPEDANCE, ACOUSTICAL SOCIETY OF AMERICA, 88TH MEETING, ST. LOUIS, MISSOURI, NOVEMBER 4-8, 1974.
- POWELL, W.B., AND R.W. RIEBLING. THE HYDRAULIC CHARACTERISTICS OF FLOW THROUGH MINIATURE SLOT ORIFICES, AMERICAN INSTITUTE OF AERONAUTICS AND ASTRONAUTICS, PROPULSION JOINT SPECIALIST CONFERENCE, 6TH, SAN DIEGO, CALIFORNIA, JUNE 15-19, 1970.
- POZZI, A. "VISCOUS JETS FROM NONNARROW ORIFICES", AIAA JOURNAL, VOL. 2 MAY, 1964, PP. 949-951.
- QUINN, B. "FLOW IN THE ORIFICE OF A RESONANT CAVITY", AIAA, STUDENT JOURNAL, VOL. 1, APRIL, 1963, PP. 1-5.
- RANGARAJU, K.G., AND A.K. JAIN. "ENERGY LOSS DUE TO SHARP-EDGED ORIFICE METERS", IRRIGATION AND POWER, VOL. 35, NO. 3, JULY, 1978, PP. 401-406.
- RAY, A.K. "ON THE EFFECT OF ORIFICE SIZE ON STATIC PRESSURE READING AT DIFFERENT REYNOLDS NUMBERS", TRANSLATED INTO ENGLISH FROM ING. ARCHIV., AERONAUTICAL RESEARCH COUNCIL, LONDON, ENGLAND, VOL. 24, NO. 3, 1956, PP. 171-181.
- RAYLE, R.E. INFLUENCE OF ORIFICE GEOMETRY ON STATIC PRESSURE MEASUREMENTS, M.I.T., CAMBRIDGE, MASSACHUSETTS, ANNUAL MEETING, ASME, ATLANTIC CITY, NOVEMBER 29-DECEMBER 4, 1959.
- RHODE, JOHN E., HADLEY T. RICHARDS, AND GEORGE W. METZGER. "DISCHARGE COEFFICIENTS FOR THICK PLATE ORIFICES WITH APPROACH FLOW PERPENDICULAR AND INCLINED TO THE ORIFICE AXIS", REPORT NO. 720-03-00-79-22, NASA LEWIS RESEARCH CENTER, CLEVELAND, OHIO, JUNE 26, 1969.
- \*ROUSE, H., AND A.H. ABUL-FETOUH. "CHARACTERISTICS OF IRROTATIONAL FLOW THROUGH AXIALLY SYMMETRIC ORIFICES", JOURNAL OF APPLIED MECHANICS, TRANS. ASME, VOL. 17, 1950, PP. 421-426.
- RUPE, J.H. ON THE DYNAMIC CHARACTERISTICS OF FREE-LIQUID JETS AND A PARTIAL CORRELATION WITH ORIFICE GEOMETRY, JET PROPULSION LAB, CALIFORNIA INSTITUTE OF TECHNOLOGY, PASADENA, CALIFORNIA, JANUARY 15, 1962.
- SCHNECKENBURG, E. FLOW OF WATER THROUGH CONCENTRIC AND ECCENTRIC CYLINDRICAL THROTTLING SLOTS WITH AND WITHOUT ANNULAR GROOVES, (DISSERTATION, TH AACHEN, 1929), ZEITSCHRIFT FUR ANGEWANDTE MATHEMATIK UND MECHANIK, VOL. 11, 1931, PP. 27-40. (GERMAN)
- SCHUMACHER, W. "INVESTIGATION OF FLOWS IN NARROW SLOTS", ING. ARCH., VOL. 1, 1930, PP. 444-448. (GERMAN)
- SHIRES, G.L. THE VISCID FLOW OF AIR IN A NARROW SLOT, AERONAUTICAL RESEARCH COUNCIL CURRENT PAPER NO. 13, 1950, (12329).
- SHORIN, V.P. "PERIODIC FLUID FLOW THROUGH ORIFICES", AVIATIONNAIA TEKHNIKA, VOL. 13, NO. 4, PP. 116-121. (RUSSIAN)

- \*SPARROW, E.M., AND S.H. LIN. "THE DEVELOPING LAMINAR FLOW AND PRESSURE DROP IN THE ENTRANCE REGION OF ANNULAR DUCTS", JOURNAL OF BASIC ENGINEERING, TRANS. ASME, SERIES D, VOL. 86, NO. 4, DECEMBER, 1965, PP. 827-834.
- STEARNS, R.F., R.M. JACKSON, R.R. JOHNSON, AND C.A. LARSON. FLOW MEASUREMENT WITH ORIFICE METERS, D. VAN NOSTRAND CO., NEW YORK, 1951.
- STOFFEL, B. "THEORETICAL CALCULATION OF THE LAMINAR THROUGH-FLOW IN ECCENTRIC GAPS OF CENTRIFUGAL PUMPS FOR FLUIDS WITH TEMPERATURE-DEPENDENT VISCOSITY", PROCEEDINGS OF THE FIFTH CONFERENCE ON FLUID MACHINERY, VOL. 2, AKADEMIAI KIADO, BUDAPEST, HUNGARY, SEPTEMBER, 15-20, 1975, PP. 1097-1107.
- STRSCHELETZKY, M. "SLOT LOSSES IN AXIAL FLOW MACHINES, ESPECIALLY KAPLAN TURBINES", FORSCH. ING.-WES., VOL. 21, NO. 4, 1955, PP. 101-106. (GERMAN)
- SZUMOWSKI, A.P. "DISCHARGE COEFFICIENTS FOR AIR OUTFLOW THROUGH A SINGLE ORIFICE IN THE WALL OF A TUBE", ARCHIWIRIM BUDOWY MASZYN, VOL. 19, NO. 4, 1972, PP. 559-564.
- \*\*TAO, L.N., AND W.F. DONOVAN. "THROUGH-FLOW IN CONCENTRIC AND ECCENTRIC ANNULI OF FINE CLEARANCE WITH AND WITHOUT RELATIVE MOTION OF THE BOUNDARIES", TRANS. ASME, VOL. 77, NO. 8, NOVEMBER, 1955, PP. 1291-1301.
- TEYSSANDIER, R.G. INTERNAL SEPARATED FLOWS EXPANSIONS, NOZZLES, AND ORIFICES, PH.D. THESIS, RHODE ISLAND UNIVERSITY, KINGSTON, RHODE ISLAND, 1973.
- \*THOM, A., AND C.J. APELT. THE PRESSURE IN A TWO-DIMENSIONAL STATIC HOLE AT LOW REYNOLDS NUMBER, ARC R & M 3090, VOL. 94, FEBRUARY, 1957, (HMSO 1958). (DDA 58-3304)
- \*\*TORIZUMI, YASUHIRO, NAOMICHI HIRAYAMA, AND TOSHIYUKI MAEDA. "METHODS OF LOSS ESTIMATION IN COMPRESSIBLE FLOW THROUGH PIPE ORIFICES AND NOZZLES", PAPER NO. 212-6, BULLETIN OF THE JAPANESE SOCIETY OF MECHANICAL ENGINEERS, VOL. 26, NO. 212, FEBRUARY, 1983, PP. 215-222.
- TRUTNOVSKY, KARL. "OCCURRENCE OF TRANSVERSE FORCES IN THE FLOW THROUGH SLOTS", VDI-ZEITSCHRIFT, VOL. 99, NO. 30, 1957, PP. 1538-1539. (GERMAN)
- WARD-SMITH, A.J. SOME ASPECTS OF FLUID FLOW IN DUCTS, (PHD THESIS), UNIVERSITY OF OXFORD, UNITED KINGDOM, 1968. (PUBLISHED BY BUTTERWORTHS 1971)
- \*\*WARD-SMITH, A.J. PRESSURE LOSSES IN DUCTED FLOWS, BUTTERWORTHS, LONDON, ENGLAND, 1971.
- \*\*WARD-SMITH, A.J. INTERNAL FLUID FLOW, THE FLUID DYNAMICS OF FLOW IN PIPES AND DUCTS, CLARENDON PRESS, OXFORD, GREAT BRITAIN, 1980.
- MEISSENBERGER, E. FLOW THROUGH SLOT SEALS, (DISSERTATION), TH KARLSRUHE, 1952. (GERMAN)

WINKEL, R. "WATER MOTION IN PIPES WITH RING SLOT FLOW CROSS-SECTION",  
Z. ANGEN. MATH. MECH., VOL. 3, 1923, PP. 251-257. (GERMAN)

MOLD, J.W. CHARACTERISTICS OF FLUID FLOW THROUGH ORIFICES IN ROTATING  
DISKS, M.S. THESIS, AIR FORCE INSTITUTE OF TECHNOLOGY, WRIGHT-  
PATTERSON AIR FORCE BASE, OHIO, MARCH, 1966.

ZAMPAGLIONE, D., AND M. GREPPI. "NUMERICAL STUDY OF A VISCOUS FLOW  
THROUGH A PIPE ORIFICE", MECCANICA, VOL. 7, SEPTEMBER, 1972, PP.  
151-164.

ZANKER, K.J. ORIFICE PLATE DISCHARGE COEFFICIENTS, BRITISH HYDRO-  
MECHANICS RESEARCH ASSOCIATION, HARLOW, ENGLAND, OCTOBER, 1961.

TOTAL NUMBER OF REFERENCES FOR ORIFICES - STATIC AND ROTATING = 145

THEORETICAL/EMPIRICAL ANALYSIS

- \*\*FLOW OF FLUIDS THROUGH VALVES, FITTINGS, AND PIPE, TECHNICAL PAPER NO. 410, CRANE CO., CHICAGO, ILLINOIS, 1969.
- \*\*FLOW OF GAS THROUGH SERIES OF CONSTRICTIONS, STRESS OFFICE DATA SHEET NO. 35, ROLLS-ROYCE, DERBY, ENGLAND, JANUARY 21, 1953.
- \*\*"FLUID DYNAMICS", SECTION 3, PROPULSION MANUAL-FUNDAMENTAL INFORMATION, VOLUME III, THE MARTIN COMPANY, JANUARY 27, 1958.
- FLUID METERS: THEIR THEORY AND APPLICATION. 6TH EDITION, ASME, NEW YORK, 1971.
- FRICTION LOSSES FOR FULLY-DEVELOPED FLOW IN STRAIGHT PIPES; ITEM NO. 66027; ENGINEERING SCIENCES DATA UNIT, LONDON, ENGLAND, 1966.
- FRICTION LOSSES FOR FULLY-DEVELOPED FLOW IN STRAIGHT PIPES OF CONSTANT CROSS SECTION - SUBSONIC COMPRESSIBLE FLOW OF GASSES, DATA ITEM NO. 74029, ESDU INTERNATIONAL LTD, LONDON, 1974.
- INTRODUCTORY MEMORANDUM ON THE PRESSURE LOSSES IN INTERNAL FLOW SYSTEMS; ITEM NO. 69016; ENGINEERING SCIENCES DATA UNIT, LONDON, ENGLAND, JULY, 1969.
- LOSSES CAUSED BY FRICTION IN STRAIGHT PIPES WITH SYSTEMATIC ROUGHNESS ELEMENTS; ITEM NO. 79014; ENGINEERING SCIENCES DATA UNIT, LONDON, ENGLAND, SEPTEMBER, 1979.
- ONE-DIMENSIONAL COMPRESSIBLE GAS FLOW IN DUCTS; ITEM NO. 74028; ENGINEERING SCIENCES DATA UNIT, LONDON, ENGLAND, 1974.
- VDI-FLOW MEASUREMENT RULES, DIN 1952. (GERMAN)
- ABBOTT, D.E., AND S.J. KLINE. "EXPERIMENTAL INVESTIGATION OF SUBSONIC TURBULENT FLOW OVER SINGLE AND DOUBLE BACKWARD FACING STEPS", JOURNAL OF BASIC ENGINEERING, TRANS. ASME, SERIES D, SEPTEMBER, 1962, P. 317.
- ABRAMOVICH, G.N. THEORY OF THE FREE-JET AND APPLICATIONS, ZAHJ REPORT NO. 293, MOSCOW, 1936. (RUSSIAN)
- ABRAMOVICH, G.N. "FREE TURBULENT JETS OF LIQUIDS AND GASES", STATE SCIENTIFIC TECHNICAL PUBLISHING HOUSE OF POWER ENGINEERING LITERATURE, MOSCOW-LENINGRAD, 1948, PP. 127-137. (RUSSIAN)
- \*\*ABRAMOVICH, G.N. THE THEORY OF TURBULENT JETS. (CHAPTER 13. JETS IN FINITE SPACE.), MIT PRESS, 1963, PP. 625-628. (DDA QA913 A213)
- \*\*AKAIKE, SHIRO, AND MITSUMASA NEMOTO. "FLOW THROUGH NARROW CLEARANCE BETWEEN ROTATING CYLINDER AND STATIONARY WALL", BULLETIN OF JSME, VOL. 27, NO. 229, JULY, 1984, PP 1378-1384.
- ALLEN, J., AND N.D. GRUNBERG. "THE RESISTANCE TO THE FLOW OF WATER ALONG SMOOTH RECTANGULAR PASSAGES AND THE EFFECT OF A SLIGHT CONVERGENCE OR DIVERGENCE OF THE BOUNDARIES", PHILOSOPHICAL MAGAZINE, VOL. 23, 1937, PP. 490-503.

- ANDERSON, O.L. A COMPARISON OF THEORY AND EXPERIMENTS FOR INCOMPRESSIBLE, TURBULENT, SWIRLING FLOWS IN AXISYMMETRIC DUCTS, AIAA PAPER 72-42, JANUARY 1972.
- ANDERSON, R.E., AND P.A. GRAHAM. A STUDY OF THE EFFECTS OF AN ORIFICE INLET ON THE PERFORMANCE OF A STRAIGHT CYLINDRICAL DIFFUSER. NAVAL AIR PROPULSION TEST CENTER, TRENTON, NEW JERSEY, DECEMBER, 1967.
- ARBHABIRAMA, A., AND T.H. WANG. "CHARACTERISTICS OF A TWO-DIMENSIONAL ORIFICE-JET PAST A RECTANGULAR PLATE", IN AUSTRALASIAN CONFERENCE ON HYDRAULICS AND FLUID MECHANICS, 5TH, CHRISTCHURCH, NEW ZEALAND, DECEMBER 9-13, 1974, PROCEEDINGS, VOL. 2, 1975, PP. 470-479.
- ASANUMA, T. "ON THE FLOW OF LIQUID BETWEEN PARALLEL WALLS IN RELATIVE MOTION", TRANS. JSME, VOL. 17, NO. 60, 1951, PP. 140-146. (JAPANESE)
- BAER, H. "PRESSURE DROP AND STATE CHANGE IN LONG GAS AND STEAM LINES", FORSCH. ING.-WES., VOL. 16, NO. 3, 1949-1950, PP. 79-84. (GERMAN)
- BARBIN, A.R., AND J.B. JONES. "TURBULENT FLOW IN THE INLET REGION OF A SMOOTH PIPE", TRANS. ASME, SERIES D, VOL. 85, NO. 29, 1963.
- BARLOW, R.I. "PROBLEMS IN FLOW MEASUREMENT", INSTRUMENTS AND CONTROL SYSTEMS, VOL. 39, MARCH, 1966, PP. 129-131.
- BARRATT, M.J., P.O.A.L. DAVIES, AND M.J. FISHER. TURBULENCE IN THE MIXING REGION OF A ROUND JET, AERONAUTICAL RESEARCH COUNCIL, LONDON, ENGLAND, APRIL 24, 1962.
- \*BATCHELOR, G.K. "ON STEADY LAMINAR FLOW WITH CLOSED STREAMLINES AT LARGE REYNOLDS NUMBERS", JOURNAL OF FLUID MECHANICS, VOL. 1, NO. 2, JULY, 1956, PP. 177-190.
- BEAVERS, G.S., AND T.A. WILSON. "VORTEX GROWTH IN JETS", JOURNAL OF FLUID MECHANICS, VOL. 44, PP. 97-112.
- BECKER, ERNST. "FLOW PROCESSES IN RING SHAPED SLOTS AND RELATIONSHIP TO THE POISEUILLE LAW", VDI-INVESTIGATION, VOL. 48, VDI-VERLAG, BERLIN, 1907, PP 1-42. (GERMAN)
- \*\*BECKER, ERNST. "FLOW PROCESSES IN ANNULAR GAPS (LABYRINTH SEALS)", (AEC-TR-4960 NTC), ZEITSCHRIFT VDI, VOL. 51, NO. 29, JULY 20, 1907, PP. 1133-1141. (DDA 80-974)
- BEGG, R.D. THE EFFECT OF DOWNSTREAM PRESSURE ASYMMETRY ON THE FLOW FROM TWO-DIMENSIONAL DRIFICES, INTERNATIONAL FEDERATION OF AUTOMATIC CONTROL, SYMPOSIUM ON FLUIDICS, PROCEEDINGS, LONDON, ENGLAND, NOVEMBER 4-8, 1968.
- \*\*BENEDICT, R.P., AND W.G. STELTZ. "A GENERALIZED APPROACH TO ONE-DIMENSIONAL GAS DYNAMICS", JOURNAL OF ENGINEERING FOR POWER, TRANS. ASME, SERIES A, JANUARY, 1962, PP. 49-68.
- BENEDICT, R.P. "SOME COMPARISONS BETWEEN COMPRESSIBLE AND INCOMPRESSIBLE TREATMENTS OF COMPRESSIBLE FLUIDS", JOURNAL OF BASIC ENGINEERING, TRANS. ASME, SERIES D, VOL. 86, NO. 3, SEPTEMBER, 1964, P. 527-537.

- \*\*BENEDICT, R.P., AND N.A. CARLUCCI. "FLOW WITH LOSSES", JOURNAL OF ENGINEERING FOR POWER, TRANS. ASME, SERIES A, VOL. 87, JANUARY, 1965, PP. 37-49.
- BENEDICT, R.P., AND M.G. STELTZ. HANDBOOK OF GENERALIZED GAS DYNAMICS, PLENUM PRESS, NEW YORK, 1966.
- \*\*BENEDICT, ROBERT P. "ON THE DETERMINATION AND COMBINATION OF LOSS COEFFICIENTS FOR COMPRESSIBLE FLUID FLOWS", JOURNAL OF ENGINEERING FOR POWER, TRANS. ASME, SERIES A, VOL. 88, JANUARY, 1966, PP. 67-72.
- BENEDICT, R.P. FUNDAMENTALS OF PIPE FLOW, JOHN WILEY AND SONS, NEW YORK, NEW YORK, 1980.
- \*\*BENSON, R.S., AND D.E. POOL. "THE COMPRESSIBLE FLOW DISCHARGE COEFFICIENTS FOR A TWO-DIMENSIONAL SLIT", INTERNATIONAL JOURNAL OF MECHANICAL SCIENCE, VOL. 7, PERGAMON PRESS, GREAT BRITAIN, PP. 337-353.
- \*\*BILGEN, E., R. BOULOS, AND A.C. AKGUNGOR. "LEAKAGE AND FRICTIONAL CHARACTERISTICS OF TURBULENT HELICAL FLOW IN FINE CLEARANCES", (PAPER NO 73-FE-1, JUNE 1973), JOURNAL OF FLUIDS ENGINEERING, TRANS. ASME, SERIES I, VOL. 95, PP. 493-497.
- BIRD, R.B., M.E. STEWART, AND E.N. LIGHTFOOT. TRANSPORT PHENOMENA, NEW YORK, JOHN WILEY AND SONS, 1960.
- BLASIUS, H. "SIMILARITY LAW FOR FRICTION PROCESSES IN LIQUIDS", VDI-FORSCH, VOL. 131, VDI-VERLAG, BERLIN, 1913, PP. 1-39. (GERMAN)
- \*BOYACK, B.E., AND W. RICE. "AN INTEGRAL SOLUTION FOR THE LAMINAR RADIAL OUTFLOW OF A VISCOUS FLUID BETWEEN PARALLEL STATIONARY DISKS", JOURNAL OF BASIC ENGINEERING, TRANS. ASME, SERIES D, NO. 3, PP. 662-663.
- \*BRAGG, S.L. "EFFECT OF COMPRESSIBILITY ON THE DISCHARGE COEFFICIENT OF ORIFICES AND CONVERGENT NOZZLES", JOURNAL OF MECHANICAL ENGINEERING SCIENCE, VOL. 2, NO. 1, 1960, PP. 35-44.
- BRAGG, S.L. "EFFECT OF COMPRESSIBILITY ON THE DISCHARGE COEFFICIENT OF ORIFICES AND CONVERGENT NOZZLES", CONSTRUCTION, VOL. 12, NO. 11, 1960, P. 517.
- \*BRIGHTON, J.A., AND J.B. JONES. "FULLY DEVELOPED TURBULENT FLOW IN ANNULI", JOURNAL OF BASIC ENGINEERING, TRANS. ASME, SERIES D, VOL. 86, NO.4, DECEMBER, 1964, PP. 835-844.
- BURGERS, J.M. FLOW OF AIR THROUGH NARROW SLOTS, (INTERNAL COMMUNICATION) LABORATORY FOR COMBUSTION MOTORS, TH DELFT. (GERMAN)
- BYIER, B.W. AN EXPERIMENTAL INVESTIGATION OF SOME ASPECTS OF THE VORTEX COOLING TUBE, NAVAL AIR DEVELOPMENT CENTER, JOHNSVILLE, PENNSYLVANIA.
- CARTER, J.E. SOLUTIONS FOR LAMINAR BOUNDARY LAYERS WITH SEPARATION AND REATTACHMENT, PAPER NO. 74-538, AIAA, 1974.

- \*\*CATHERMAN, E.B. SIMPLIFICATION OF FLUID-FLOW COMPUTATIONS FOR ORIFICE METERS, M.S. THESIS, TEXAS TECHNOLOGICAL COLLEGE, LUBBOCK, TEXAS, MAY, 1965.
- \*CHAPLYGIN, S. GAS JETS, NACA TM 1063, (TRANSLATION: MOSCOW UNIVERSITY, 1902), WASHINGTON, AUGUST, 1944.
- CHATURVEDI, M.C. "FLOW CHARACTERISTICS OF AXISYMMETRIC EXPANSIONS", JOURNAL OF THE HYDRAULICS DIVISION, PROCEEDINGS OF THE AMERICAN SOCIETY OF CIVIL ENGINEERS, VOL. 89, HY-3, MAY 1963, PP. 61-92.
- CHERVINSKY, A., AND N. CHIGIER. EXPERIMENTAL AND THEORETICAL STUDY OF TURBULENT SWIRLING JETS ISSUING FROM A ROUND ORIFICE, ISRAEL INSTITUTE OF TECHNOLOGY, DEPARTMENT OF AERONAUTICAL ENGINEERING, NOVEMBER, 1965.
- \*CLARK, J.A. "A STUDY OF INCOMPRESSIBLE TURBULENT BOUNDARY LAYERS IN CHANNEL FLOW", JOURNAL OF BASIC ENGINEERING, TRANS. ASME, SERIES D, VOL. 90, NO. 4, DECEMBER, 1968, PP. 455-468.
- CLARK, W.J. FLOW MEASUREMENT, OXFORD, PAREGAMON PRESS, LTD., 1965.
- COLE, J.A. "EXPERIMENTS ON THE FLOW IN ROTATING ANNULAR CLEARANCES", PROCEEDINGS OF THE CONFERENCE ON LUBRICATION AND WEAR, PAPER 15, INSTITUTION OF MECHANICAL ENGINEERS, LONDON, OCTOBER 1-3, 1957, PP. 16-19.
- COLEBROOK, C.F. "TURBULENT FLOW IN PIPES, WITH PARTICULAR REFERENCE TO THE TRANSITION REGION BETWEEN THE SMOOTH AND ROUGH PIPE LAWS", JOURNAL OF THE INSTITUTION OF CIVIL ENGINEERS, VOL. 11, LONDON, FEBRUARY, 1939, PP.133-156.
- COMOLET, R. FLOW OF A FLUID BETWEEN TWO PARALLEL PLANES, CONTRIBUTION TO THE STUDY OF AIR FIELDS, PUBLICATIONS SCIENTIFIQUES ET TECHNIQUES DU MINISTERE DE L'AIR, NO. 334, 1957. (FRENCH)
- CORNISH, R.J. "FLOW IN A PIPE OF RECTANGULAR CROSS SECTION", PROCEEDINGS OF THE ROYAL SOCIETY OF LONDON, SERIES A, VOL. 120, 1928, PP. 691-700.
- CORNISH, R.J. "FLOW OF WATER THROUGH FINE CLEARANCE WITH RELATIVE MOTION OF THE BOUNDRIES", PROCEEDINGS OF THE ROYAL SOCIETY OF LONDON, VOL. 140A, 1933, P. 227.
- \*CRAWFORD, M.E., AND W.M. KAYS. STANS - A PROGRAM FOR NUMERICAL COMPUTATION OF TWO-DIMENSIONAL INTERNAL AND EXTERNAL BOUNDARY LAYER FLOWS, NASA CR-2742, 1976. (DDA 77-167)
- CROSS, H. ANALYSIS OF FLOW IN NETWORKS OF CONDUITS OR CONDUCTORS, UNIVERSITY OF ILLINOIS BULLETIN 286, NOVEMBER, 1946.
- DALLE-DONNE, M., AND F.H. BOWDITCH. "HIGH TEMPERATURE HEAT TRANSFER", NUCLEAR ENGINEERING, VOL. 8, 1963, PP. 20-29.
- DAVIES, S.J., AND C.M. WHITE. "AN EXPERIMENTAL STUDY OF THE FLOW OF WATER IN PIPES OF RECTANGULAR SECTION", PROCEEDINGS OF THE ROYAL SOCIETY OF LONDON, SERIES A, VOL. 119, 1928, PP. 92-107.

- \*DEISSLER, ROBERT G. ANALYSIS OF TURBULENT HEAT TRANSFER AND FLOW IN THE ENTRANCE REGIONS OF SMOOTH PASSAGES, NACA TN 3016, 1953.  
(DDA 53-1518)
- DEISSLER, ROBERT G., AND M.F. TAYLOR. ANALYSIS OF FULLY DEVELOPED TURBULENT HEAT TRANSFER AND FLOW IN AN ANNULUS WITH VARIOUS ECCENTRICITIES, NACA TN 3451, 1955.
- DIPRIMA, R.C. "VISCIOUS FLOW BETWEEN ROTATING CONCENTRIC CYLINDERS WITH A CIRCUMFERENTIAL PRESSURE GRADIENT AT SPEEDS ABOVE CRITICAL", ASLE TRANS., VOL. 7, NO. 4, OCTOBER, 1964, P. 333.
- \*DIPRIMA, R.C., AND J.T. STUART. "FLOW BETWEEN ROTATING CYLINDERS", JOURNAL OF LUBRICATION TECHNOLOGY, TRANS. ASME, SERIES F, NO. 3, JULY, 1972, PP. 266-274.
- \*\*DOLLIN, F., AND W.S. BROWN. "FLOW OF FLUIDS THROUGH OPENINGS IN SERIES", THE ENGINEER, VOL. 164, NO. 4259, AUGUST 27, 1937, PP. 223-224.
- DONOVAN, L. "NUMERICAL SOLUTION OF UNSTEADY FLOW IN A TWO-DIMENSIONAL SQUARE CAVITY", JOURNAL OF AMERICAN INSTITUTE OF AERONAUTICS AND ASTRONAUTICS, VOL. 8, NO. 3, MARCH, 1970, PP. 524-529.
- DURST, F., AND A.K. RASTOGI. "THEORETICAL AND EXPERIMENTAL INVESTIGATION OF TURBULENT FLOWS WITH SEPARATION", PROCEEDINGS OF THE FIRST SYMPOSIUM ON TURBULENT SHEAR FLOWS, VOL. 1, 1977, P. 18.1.
- EASTLAKE, C.N., II. VELOCITY MEASUREMENTS IN PARTIALLY CONFINED RECTANGULAR JETS, SYSTEMS RESEARCH LABORATORIES, DAYTON, OHIO.
- \*EATON, J.K., A.H. JEANS, J. ASHJAEI, AND J.P. JOHNSTON. "A WALL-FLOW-DIRECTION PROBE FOR USE IN SEPARATING AND REATTACHING FLOWS", JOURNAL OF FLUIDS ENGINEERING, TRANS. ASME, SERIES I, VOL. 101, NO. 3, SEPTEMBER, 1979, PP 364-366.
- ECK, B. TECHNICAL FLUID DYNAMICS, 6TH ED, SPRINGER, BERLIN, 1960.  
(GERMAN)
- ECKERT, E.R., AND T.F. IRVINE, JR. "INCOMPRESSIBLE FRICTION FACTOR, TRANSITION, AND HYDRODYNAMIC ENTRANCE-LENGTH STUDIES OF DUCTS WITH TRIANGULAR AND RECTANGULAR CROSS SECTIONS", PROCEEDINGS OF THE 5TH MIDWESTERN CONFERENCE ON FLUID MECHANICS, UNIVERSITY OF MICHIGAN PRESS, 1957, PP. 122-145.
- \*\*EGLI, ADOLF. "THE LEAKAGE OF GASES THROUGH NARROW CHANNELS", JOURNAL OF APPLIED MECHANICS, TRANS. ASME, VOL. 59, 1937, PP. 63-67.  
(DISCUSSION: JOURNAL OF APPLIED MECHANICS, TRANS. ASME, 1938, PP. 36-37.)
- EHRHARDT, G. "ELIMINATION OF THE INFLUENCE OF INSTALLATION DISTURBANCE ON FLOW MEASUREMENTS WITH ORIFICE PLATES", NATIONAL LENDING LIBRARY, BOSTON SPA, ENGLAND, BRENNSTAFF-WAERME-KRAFT, VOL. 24, NO. 12, 1972, PP. 449-452.

- FAVRE, A.J. "THE EQUATIONS OF COMPRESSIBLE TURBULENT GASES", ANNUAL SUMMARY REPORT NO. 1, INSTITUTE OF MECHANIQUE STATISTIQUE DA LA TURBULENCE, JANUARY, 1965.
- \*FLEMING, DAVID P., AND E.M. SPARROW. "FLOW IN THE HYDRODYNAMIC ENTRANCE REGION OF DUCTS OF ARBITRARY CROSS-SECTION", JOURNAL OF HEAT TRANSFER, TRANS. ASME, VOL. 91, NO. 3, AUGUST, 1969, PP. 345-354.
- FLUGEL, G. "CALCULATION OF JET DEVICES", VDI FORSCH., VOL. 395, 2ND ED., VDI-VERLAG, DUSSELDORF, 1951. (GERMAN)
- FOERTHMANN, E. TURBULENT JET EXPANSION, NACA TM 789, 1936.
- FORSTE, J. "STATIONARY EXPANSION OF A LAMINAR JET OF VISCOUS INCOMPRESSIBLE FLUID FROM AN ANNULAR ORIFICE INTO A HALF-SPACE AT LOW REYNOLDS NUMBER", REVUE OF MECANIQUE APPLIQUEE, VOL. 7, NO. 6, 1972, PP. 1099-1106. (GERMAN)
- \*\*FOX, ROBERT W., AND ALAN T. MCDONALD. INTRODUCTION TO FLUID MECHANICS, JOHN WILEY & SONS, NEW YORK, 1973, PP. 309-460.
- \*FROMM, J.E. A METHOD FOR COMPUTING NON-STEADY INCOMPRESSIBLE VISCOUS FLUID FLOWS, REPORT LA-2910, LOS ALAMOS SCIENTIFIC LABORATORY, UNIVERSITY OF CALIFORNIA PRESS, MAY, 1963. (DDA 65-1710)
- GECK, M. PRESSURE LOSS AND HEAT TRANSFER OF LAMINAR FLOWING GAS IN NARROW CHANNELS, (DISSERTATION), TH KARLSRUHE, 1953. (GERMAN)
- GELHAR, L.W., AND P.L. MONKMEYER. "TURBULENT HELICAL FLOW IN AN ANNULUS", PROCEEDINGS OF THE AMERICAN SOCIETY OF CIVIL ENGINEERS, 1968, P. 295.
- GHAZI, H.S. A PRESSURE INDEX FOR PREDICTING THE EFFECT OF FLOW PROFILES ON ORIFICE METER PERFORMANCE, ASME, WINTER ANNUAL MEETING, CHICAGO, ILLINOIS, NOVEMBER 7-11, 1965, PAPER 65-WA/FM-3.
- GHAZI, H.S. ON NONUNIFORM FLOW CHARACTERISTICS AT THE VENA CONTRACTA, ASME, FLUIDS ENGINEERING, HEAT TRANSFER, AND LUBRICATION CONFERENCE, DETROIT, MICHIGAN, MAY 24-27, 1970.
- \*GOLDSTEIN, SYDNEY, EDITOR. MODERN DEVELOPMENTS IN FLUID DYNAMICS, VOL. 1, DOVER PUBLICATIONS, 1938. (DDA TL570 G55)
- GOSMAN, A.D., AND W.M. PUN. CALCULATION OF RECIRCULATING FLOWS, HTS/73/2, DEPARTMENT OF MECHANICAL ENGINEERING, IMPERIAL COLLEGE, LONDON, 1973.
- \*\*GREEN, JR., LEON, AND POL DUWEZ. "FLUID FLOW THROUGH POROUS METALS", JOURNAL OF APPLIED MECHANICS, TRANS. ASME, VOL. 18, NO. 1, MARCH, 1951, PP. 39-45.
- \*GRINELL, S.K. "FLOW OF A COMPRESSIBLE FLUID IN A THIN PASSAGE", TRANS. ASME, VOL. 78, 1956, PP. 765-771.
- HAALAND, S.E. "SIMPLE AND EXPLICIT FORMULAS FOR THE FRICTION FACTOR IN TURBULENT PIPE FLOW", JOURNAL OF FLUIDS ENGINEERING, VOL. 105, MARCH, 1983, PP. 89-90.

- \*\*HAGSTROM, E. "FLOW-PRESSURE DROP EQUATION SIMPLIFIES PNEUMATIC DESIGN", HYDRAULICS & PNEUMATICS, OCTOBER, 1985, PP. 74-77.
- HAHNEMANN, H.M. "CONTOURS OF FREE OUTFLOW JETS AND THEIR TECHNICAL APPLICATION", FORSCH. ING.-WES., VOL. 18, NO. 2, 1952, PP. 45-55. (GERMAN)
- HARTNETT, J.P., J.C.Y. KOH, AND S.T. MCCOMAS. "A COMPARISON OF PREDICTED AND MEASURED FRICTION FACTORS FOR TURBULENT FLOW THROUGH RECTANGULAR DUCTS", JOURNAL OF HEAT TRANSFER, TRANS. ASME, VOL. 84, 1962, PP. 82-88.
- HAUGEN, R.L., AND A.M. DHANAK. "MOMENTUM TRANSFER IN TURBULENT SEPARATED FLOW PAST A RECTANGULAR CAVITY", TRANSACTIONS OF THE ASME, SERIES E, JOURNAL OF APPLIED MECHANICS, VOL. 88, SEPTEMBER, 1966, PP. 641-646.
- HENDRICKS, R.C. SOME ASPECTS OF A FREE JET PHENOMENA TO 105 L/D IN A CONSTANT AREA DUCT, PAPER B1-78, XV CONGRESS OF REFRIGERATION, VENICE, ITALY, SEPTEMBER 23-29, 1979.
- HENDRICKS, R.C. A FREE JET PHENOMENA IN A 90 DEGREE - SHARP EDGE INLET GEOMETRY, PAPER SUBMITTED TO CRYOGENIC ENGINEERING CONFERENCE, UNIVERSITY OF WISCONSIN, MADISON, AUGUST 21-24, 1979.
- \*\*HENDRICKS, R.C. A COMPARISON OF FLOW RATES AND PRESSURE PROFILES FOR N-SEQUENTIAL INLETS AND THREE RELATED SEAL CONFIGURATIONS, NASA-TM-83442, AUGUST 19, 1983.
- HINZE, J.O. TURBULENCE, 2ND EDITION, NEW YORK, MCGRAW HILL BOOK CO., 1975.
- HJELMFELT, A.T., AND L.F. MOCKROS. "MOTION OF DISCRETE PARTICLES IN A TURBULENT FLUID", APPL. SCI. RES., VOL. 16, 1966, PP. 149-161.
- HOCHREUTHER, W. FORCES GENERATED BY AXIAL FLOW THROUGH GAPS, (DISSERTATION), UNIVERSITY OF STUTTGART, 1975. (GERMAN)
- HOERNER, S.F. THE FLUID DYNAMICS OF DRAG, 2ND EDITION, MIDLAND PARK, NEW JERSEY, 1965.
- \*HORTON, H.P. "A SEMI-EMPIRICAL THEORY FOR THE GROWTH AND BURSTING OF LAMINAR SEPARATION BUBBLES", C.P. NO. 1073, AERONAUTICAL RESEARCH COUNCIL. (DDA 70-2680)
- \*\*HOWELL, GLEN W., AND TERRY M. WEATHERS. "3.0 FLUID MECHANICS", AEROSPACE FLUID COMPONENT DESIGNERS' HANDBOOK, RPL-TDR-64-25, VOLUME 1, TRW SYSTEMS GROUP, REDONDO BEACH, CALIFORNIA, FEBRUARY, 1970.
- HUNT, B.W. "NUMERICAL SOLUTION OF AN INTEGRAL EQUATION FOR FLOW FROM A CIRCULAR ORIFICE", JOURNAL OF FLUID MECHANICS, VOL. 31, JANUARY, 1968, PP. 361-377.
- \*HURD, A.C., AND A.R. PETERS. "ANALYSIS OF FLOW SEPARATION IN A CONFINED TWO-DIMENSIONAL CHANNEL", JOURNAL OF BASIC ENGINEERING, TRANS. ASME, SERIES D, VOL. 92, NO. 4, DECEMBER, 1970, PP. 908-914.

- IANSKIN, B.I. "LEAKAGE OF VISCOUS FLUIDS THROUGH RING-SHAPED AND RECTANGULAR SLOTS", MNTV GIDROMASINOSTROENIE, NO. 5, 1949. (RUSSIAN)
- \*ISHIZAWA, S. "THE AXISYMMETRIC LAMINAR FLOW IN AN ARBITRARILY SHAPED NARROW GAP", BULLETIN OF THE JSME, VOL. 8, NO. 31, 1965, PP. 353-365.
- ITO, H. "FRICTION FACTORS FOR TURBULENT FLOW IN CURVED PIPES", JOURNAL OF BASIC ENGINEERING, TRANS. ASME, SERIES D, VOL. 81, NO. 2, JUNE, 1959, PP. 123-134.
- ITO, J.I. "A GENERAL MODEL DESCRIBING HYDRAULIC FLIP IN SHARP EDGE ORIFICES", AEROJET LIQUID ROCKET CO., SACRAMENTO, CALIFORNIA, IN APL, 7TH ANNUAL JANNAF COMBUST. MEETING, VOL. 1, FEBRUARY, 1971, PP. 417-426.
- ITO, S., K. OGAWA, AND N. SHIRAGAMI. "FLOW OF DILUTE POLYMER SOLUTION IN A CIRCULAR PIPE", JOURNAL OF CHEMICAL ENGINEERING OF JAPAN, VOL. 13, NO. 1, FEBRUARY, 1980, PP. 1-5.
- JAKOB, M.C. "ON THE COEFFICIENTS OF CONTRACTION OF GAS JETS", REPR. FROM BULL. MATH. SOC. REUMAINE SCI., BUCHAREST, VOL. 40, NO. 1-2, 1938, PP. 1-6. (FRENCH)
- \*\*JONES, JR., D.C. AN IMPROVEMENT IN THE CALCULATION OF TURBULENT FRICTION IN RECTANGULAR DUCTS, PAPER NO. 75-WA/FE-12, ASME, WINTER ANNUAL MEETING, HOUSTON, TEXAS, NOVEMBER 30-DECEMBER 4, 1975.
- \*JONSSON, V.K., AND E.M. SPARROW. "EXPERIMENTS ON TURBULENT-FLOW PHENOMENA IN ECCENTRIC ANNULAR DUCTS", JOURNAL OF FLUID MECHANICS, VOL. 25, PART 1, MAY, 1966, PP. 65-86.
- \*\*KABZA, Z., E. RUTKOWSKI, AND M. SASIADEK. "FORMULAS FOR CALCULATING THE FLOW COEFFICIENT OF STANDARD CONSTRICTIONS BY DIGITAL COMPUTER", POMIARY AUTOMATYKA, KONTROLA, VOL. 17, PP. 67-70, 1975. (POLISH)
- KAWAGUTI, M. "NUMERICAL SOLUTION OF THE NAVIER-STOKES EQUATIONS FOR THE FLOW IN A TWO-DIMENSIONAL CAVITY", JOURNAL OF THE PHYSICAL SOCIETY OF JAPAN, VOL. 16, 1961, PP. 2307-2315.
- \*KAYE, J., AND E.C. ELGAR. "MODES OF ADIABATIC AND DIABATIC FLOW IN AN ANNULUS WITH AN INNER ROTATING CYLINDER", TRANS. ASME, VOL. 80, NO. 3, 1958, PP. 753-765.
- KEENAN, J.H., AND E.P. NEUMAN. "MEASUREMENTS OF FRICTION IN A PIPE FOR SUBSONIC AND SUPERSONIC FLOW OF AIR", JOURNAL OF APPLIED MECHANICS, TRANS. ASME, VOL. 13, NO. 2, 1946.
- \*KELLER, H.B., AND T. CEBECI. "AN INVERSE PROBLEM IN BOUNDARY LAYER FLOWS - NUMERICAL DETERMINATION OF PRESSURE GRADIENT FOR A GIVEN WALL SHEAR", JOURNAL OF COMPUTATIONAL PHYSICS, VOL. 10, AUGUST, 1972, PP. 151-161.
- KELNHOFER, W.J., AND R.A. SMITH. TESTING OF GAS TURBINE HIGH VELOCITY DUCT SYSTEMS, CATHOLIC UNIVERSITY OF AMERICA, WASHINGTON, D.C., (NAVAL SHIP ENGINEERING CENTER, CONTRACT NOBS 92176), AUGUST, 1966.

- KEMLER, EMORY. "A STUDY OF DATA ON THE FLOW OF FLUIDS IN PIPES",  
 HYD-55-2, TRANS. ASME, VOL. 55, 1933.
- KENDALL, JAMES M. EXPERIMENTAL STUDY OF A COMPRESSIBLE VISCOUS VORTEX,  
 JET PROPULSION LAB, CALIFORNIA INSTITUTE OF TECHNOLOGY, PASADENA,  
 CALIFORNIA, JUNE 5, 1962.
- \*\*KNUDSEN, JAMES G., AND DONALD L. KATZ. FLUID DYNAMICS AND HEAT  
 TRANSFER, MCGRAW-HILL, NEW YORK, 1958, PP. 193-197.
- KOCH, R., AND K. FEIND. "PRESSURE LOSS AND HEAT TRANSFER IN RING  
 SLOTS", CHEMIE-ING.-TECHN., VOL. 30, NO. 9, 1958, PP. 577-584.  
 (GERMAN)
- \*\*KUNKLE, JOHN S., SAMUEL D. WILSON, AND RICHARD A. COTA. COMPRESSED  
 GAS HANDBOOK, NASA SP-3045, JOHN F. KENNEDY SPACE CENTER, FLORIDA,  
 1970, PP. 201-297.
- LADYZHENSKA, O.A. THE MATHEMATICAL THEORY OF VISCOUS INCOMPRESSIBLE  
 FLOW, GORDON & BREACH SCIENCE PUBLISHERS, NEW YORK, 1963.
- LANGHAAR, H.L. "STEADY FLOW IN THE TRANSITION LENGTH OF A STRAIGHT  
 TUBE", JOURNAL OF APPLIED MECHANICS, VOL. 9, 1942.
- LAUFER, J. INVESTIGATION OF TURBULENT FLOWS IN A TWO-DIMENSIONAL  
 CHANNEL, NACA REPORT 1053, 1951.
- LEA, F.C., AND A.G. TADROS. "FLOW OF WATER THROUGH A CIRCULAR TUBE  
 WITH A CENTRAL CORE AND THROUGH RECTANGULAR TUBES", PHILOSOPHICAL  
 MAGAZINE, VOL. 11, 1931, PP. 1235-1247.
- LEVY, R., H. McDONALD, AND W.R. BRILEY. "CALCULATION OF THREE-  
 DIMENSIONAL TURBULENT SUBSONIC FLOWS IN TRANSITION DUCTS",  
 PROCEEDINGS OF THE SIXTH INTERNATIONAL CONFERENCE ON NUMERICAL  
 METHODS IN FLUID DYNAMICS, SPRINGER-VERLAG, 1979, PP. 184-192.
- \*LEVY, S. "TURBULENT FLOW IN AN ANNULUS", TRANS. ASME, SERIES C,  
 VOL. 89, NO. 1, FEBRUARY, 1967, PP. 25-31.
- LOFTIN, JR., LAURENCE K. EFFECTS OF SPECIFIC TYPES OF SURFACE  
 ROUGHNESS ON BOUNDARY-LAYER TRANSITION, NACA WR L-46, (FORMERLY  
 NACA ACR L5J29A), 1946.
- \*LOHRENZ, J., AND F. KURATA. "A FRICTION FACTOR PLOT FOR SMOOTH  
 CIRCULAR CONDUITS, CONCENTRIC ANNULI, AND PARALLEL PLATES",  
 INDUSTRIAL AND ENGINEERING CHEMISTRY, VOL. 52, 1960, P. 703.
- LORENZ, F.R. "TURBULENT FLOW THROUGH TUBES WITH CIRCULAR RING CROSS-  
 SECTION", MITT. INST. STROMUNGSMASCH., TH KARLSRUHE, HRSG. V.  
 SPANHAKE, NO. 2, 1932, P. 26. (GERMAN)
- \*LUNDGREN, T.S., E.M. SPARROW, AND J.B. STAIR. "PRESSURE DROP DUE TO  
 THE ENTRANCE REGION IN DUCTS OF ARBITRARY CROSS-SECTION", JOURNAL  
 OF BASIC ENGINEERING, TRANS. ASME, VOL. 86, NO. 3, SEPTEMBER, 1964,  
 PP. 620-626.
- MABEY, D.G. THE FORMATION AND DECAY OF VORTICES, (MS THESIS),  
 LONDON UNIVERSITY, 1955.

- MAEKAWA, T., AND S. ATSUMI. TRANSITION CAUSED BY THE LAMINAR FLOW SEPARATION, NACA TM 1352, SEPTEMBER, 1952.
- \*MCADAMS, WILLIAM H. "FLOW OF FLUIDS", CHAPTER 6, HEAT TRANSMISSION, 3RD EDITION, MCGRAW-HILL BOOK CO., NEW YORK, 1954, PP. 140-164.
- \*MCCOMAS, S.T., AND E.R.G. ECKERT. "LAMINAR PRESSURE DROP ASSOCIATED WITH THE CONTINUUM ENTRANCE REGION AND FOR SLIP FLOW IN A CIRCULAR TUBE", JOURNAL OF APPLIED MECHANICS, VOL. 32, NO. 4, DECEMBER, 1965, PP. 765-770.
- MCDONALD, H. COMPUTATIONAL FLUID DYNAMIC ASPECTS OF INTERNAL FLOWS, AIAA PAPER 79-1445, JULY, 1979.
- MCDONALD, H., AND W.R. BRILEY. "THREE-DIMENSIONAL FLOW OF A VISCOUS OR INVISCID GAS", J. COMP. PHYSICS, VOL. 19, NO. 2, 1975, P. 150.
- \*MCHUGH, J.D. "ADIABATIC LAMINAR FLOW IN CONCENTRIC SLEEVE SEALS", JOURNAL OF THE AMERICAN SOCIETY OF LUBRICATION ENGINEERS, ASLE, VOL. 22, NO. 1, JANUARY, 1966, PP. 17-22.
- METER, D.M., AND R.B. BIRD. "TURBULENT NEWTONIAN FLOW IN AN ANNULI", AICHE JOURNAL, VOL. 7, 1961, P. 41.
- \*\*MILLER, DONALD S. INTERNAL FLOW SYSTEMS, BHRA FLUID ENGINEERING SERIES, VOLUME 5, BRITISH HYDROMECHANICS RESEARCH ASSOCIATION, BHRA FLUID ENGINEERING, ENGLAND, 1978.
- \*\*MILLER, DONALD S. COMPRESSIBLE INTERNAL FLOW, BHRA FLUID ENGINEERING SERIES, VOLUME 10, BRITISH HYDROMECHANICS RESEARCH ASSOCIATION, BHRA FLUID ENGINEERING, ENGLAND, 1984.
- MILLS, R.D. FLOW IN RECTANGULAR CAVITIES, (PHD DISSERTATION), LONDON UNIVERSITY, 1961.
- \*MILLS, R.D. "ON THE CLOSED MOTION OF A FLUID IN A SQUARE CAVITY", JOURNAL OF THE ROYAL AERONAUTICAL SOCIETY, VOL. 69, FEBRUARY, 1965, PP. 116-120.
- \*\*MILLS, RONALD D. "NUMERICAL SOLUTIONS OF THE VISCOUS FLOW EQUATIONS FOR A CLASS OF CLOSED FLOWS", JOURNAL OF THE ROYAL AERONAUTICAL SOCIETY, VOL. 69, OCTOBER, 1965, PP. 714-718.
- \*MILNE-THOMPSON, L.M. THEORETICAL AERODYNAMICS, 2ND ED., MACMILLAN AND CO., LONDON, 1949, P. 285. (QA930 M54)
- MISES, R.V. CALCULATION OF OUTFLOW AND OVERFLOW COEFFICIENTS, Z. VDI, 1917, PP. 447-452, 469-474, 493-498. (GERMAN)
- MIYAKE, K., AND KAZUNARI KOMOTORI. ON THE FLOW COEFFICIENT OF AN ANNULAR CONSTRICTION, (UNPUBLISHED).
- \*MIZUSHINA, T. "ANALOGY BETWEEN FLUID FRICTION AND HEAT TRANSFER IN ANNULI", GENERAL DISCUSSION ON HEAT TRANSFER, SECTION II, INSTITUTION OF MECHANICAL ENGINEERS, LONDON, SEPTEMBER, 1951. (ODA QC320 I5)

- MIZUSHINA, T. "ANALOGY BETWEEN FLUID FRICTION AND HEAT TRANSFER IN ANNULI", BWK, 1952, P. 78. (GERMAN)
- MOBIUS, H. "EXPERIMENTAL INVESTIGATION OF THE RESISTANCE AND VELOCITY DISTRIBUTION IN TUBES WITH REGULAR ROUGHNESS FOR TURBULENT FLOW", PHYS. Z., VOL. 41, 1940, PP. 202-225. (GERMAN)
- MOLLO-CHRISTENSEN, E. "RECTIFICATION OF OSCILLATIONS IN FLUIDS", AIR, SPACE, AND INSTRUMENTS-DRAPER ANNIVERSARY VOLUME, NEW YORK, MCGRAW-HILL CO., INC., 1963, PP. 446-451.
- MOODY, L.F. "FRICTION FACTORS FOR PIPE FLOW", JOURNAL OF BASIC ENGINEERING, TRANS. ASME, VOL. 66, NO. 8, NEW YORK, NOVEMBER, 1944, PP. 671-684.
- MOORE, JOHN, AND JOAN G. MOORE. "A CALCULATION PROCEDURE FOR THREE-DIMENSIONAL, VISCOUS, COMPRESSIBLE DUCT FLOW, PART 1-INVISCID FLOW CONSIDERATIONS", (ASME PAPER 79-WA/FE-4), FLOW IN PRIMARY, NONROTATING PASSAGES OF TURBOMACHINES, PROCEEDINGS OF WINTER ANNUAL MEETING, ASME, 1979, PP. 75-88. TJ267 F56.
- MOORE, JOHN, AND JOAN G. MOORE. "A CALCULATION PROCEDURE FOR THREE-DIMENSIONAL, VISCOUS, COMPRESSIBLE DUCT FLOW, PART 2-STAGNATION PRESSURE LOSSES IN A RECTANGULAR ELBOW", (ASME PAPER 79-WA/FE-5), FLOW IN PRIMARY, NONROTATING PASSAGES OF TURBOMACHINES, PROCEEDINGS OF WINTER ANNUAL MEETING, ASME, 1979, PP. 75-88. TJ267 F56.
- \*\*MOREL, THOMAS, AND NAGI N. MANSOUR. THE DEVELOPMENT OF TURBULENT MODELS FOR COMPLEX TURBULENT FLOWS, ESPECIALLY NEAR WALL SUBMODELS, RESEARCH REPORT FD-233, FLUID DYNAMICS DEPARTMENT, GENERAL MOTORS RESEARCH LABORATORIES, WARREN, MICHIGAN, AUGUST 28, 1980.
- \*NEWBERG, L.A. "EFFECTS OF TEMPERATURE RISE ON THE FLOW OF A VISCOUS LIQUID THROUGH A CONCENTRIC ANNULUS WITH AN INNER CYLINDER ROTATING", JOURNAL OF MECHANICAL ENGINEERING SCIENCE, VOL. 6, NO. 3, SEPTEMBER, 1964, PP. 258-263.
- NEWMAN, B.G., R.P. PATEL, S.B. SAVAGE, AND H.K. TJIO. "THREE-DIMENSIONAL WALL JET ORIGINATING FROM A CIRCULAR ORIFICE", AERONAUTICAL QUARTERLY, VOL. 23, AUGUST, 1979, PP. 188-200.
- NIKURADSE, J. "LAWS OF TURBULENT FLOWS IN SMOOTH PIPES", VDI FORSCH., VOL. 356, VDI VERLAG, BERLIN. (GERMAN)
- NIKURADSE, J. "FLOW LAWS IN ROUGH PIPES", VDI FORSCH., VOL. 361, VDI VERLAG, BERLIN, 1933. (GERMAN)
- O'BRIEN, M.P., AND G.H. HICKOX. APPLIED FLUID MECHANICS, MCGRAW-HILL, NEW YORK, 1937.
- OGUCHI, H., S.I. SATO, AND O. INOUE. "EXPERIMENTAL STUDY ON FREE JET EXPANSION FROM DOUBLE CONCENTRIC ORIFICES TO VACUUM", JAPAN SOCIETY FOR AERONAUTICAL AND SPACE SCIENCES, TRANSACTIONS, VOL. 14, NO. 25, 1971, PP. 72-79.
- \*\*OHTMER, O. "NONLINEAR FLOW ANALYSIS IN PIPE NETWORKS", INTERNATIONAL JOURNAL FOR NUMERICAL METHODS IN ENGINEERING, VOL. 19, 1983, PP. 373-392.

- \*OWER, E., AND R.C. PANKHURST. THE MEASUREMENT OF AIR FLOW, PERGAMON PRESS, OXFORD, ENGLAND, 1966. (DDA TJ1025 08)
- PACHE, W., MEASURING THE MEAN STATIC PRESSURE IN TURBULENT OR HIGH-FREQUENCY FLUCTUATING FLOWS, DISA INFORMATION 2, 1977, P. 29.
- \*PAI, SHIH-I. FLUID DYNAMICS OF JETS, D. VAN NOSTRAND, NEW YORK, 1954. (DDA QA911 P3)
- \*PAI, SHIH-I. VISCOUS FLOW THEORY,  
VOL I. LAMINAR FLOW, 1956  
VOL II. TURBULENT FLOW, 1957  
D. VAN NOSTRAND, PRINCETON, NEW JERSEY. (DDA QA911 P3)
- \*PATANKAR, S.V., AND D.B. SPALDING. HEAT AND MASS TRANSFER IN BOUNDARY LAYERS, 2ND EDITION, INTERNATIONAL TEXT BOOK COMPANY, LONDON, 1970. (DDA QA913 P37)
- \*PAYNE, R.B. A NUMERICAL METHOD FOR CALCULATING THE STARTING AND PERTURBATION OF A TWO-DIMENSIONAL JET AT LOW REYNOLDS NUMBER, R&M NO. 3047, VOL. 93, BRITISH AERONAUTICAL RESEARCH COMMITTEE, JUNE, 1956, (HMSO 1958). (DDA 58-1088)
- PETERMANN, H. CONSTRUCTIONS AND ELEMENTS OF FLOW MACHINES, SPRINGER, BERLIN, 1960. (GERMAN)
- PETERMANN, H., M. PEKRUN, AND B. STAMPA. "INFLUENCE OF SPEED ON THE LEAKAGE OF ANNULI". PROCEEDINGS OF THE INTERNATIONAL SYMPOSIUM ON PUMPS AND POWER STATIONS, BRAUNSCHWEIG, SEPTEMBER 7-9, 1966, P. J15.
- PEUBE, J.L. "DEVELOPMENT OF THE WAKE IN ALTERNATING FLOWS", RECENT RESEARCH ON UNSTEADY BOUNDARY LAYERS, SYMPOSIUM, QUEBEC, CANADA, MAY 24-28, 1971, PROCEEDINGS, VOL. 1, QUEBEC, PRESSES DE L'UNIVERSITE LAVAL, 1972, PP. 448-461. (FRENCH)
- PEYRET, R., AND H. VIVIAND. "COMPUTATION OF VISCOUS COMPRESSIBLE FLOWS BASED ON THE NAVIER-STOKES EQUATIONS", AGARD-AG-212, 1975.
- PIERCY, N.A.V., M.S. HOOPER, AND H.F. WINNY. "VISCOUS FLOW THROUGH PIPES WITH CORES". PHILOSOPHICAL MAGAZINE, VOL. 15, NO. 7, 1933, PP. 647-676.
- PIGOTT, R.J.S. "THE FLOW OF FLUIDS IN CLOSED CONDUITS", MECHANICAL ENGINEERING, VOL. 55, NO. 8, AUGUST, 1938, PP. 497-501.
- PIVIROTTI, T.J. RADIAL STATIC PRESSURE DISTRIBUTIONS IN CONFINED COMPRESSIBLE VORTEX FLOW FIELDS, JET PROPULSION LAB, CALIFORNIA INSTITUTE OF TECHNOLOGY, PASADENA, CALIFORNIA, MARCH 1, 1967.
- \*\*PLETCHER, RICHARD H. PREDICTION OF INCOMPRESSIBLE TURBULENT SEPARATING FLOW, (ASME PAPER 78 WA/FE-4). JOURNAL OF FLUIDS ENGINEERING, TRANS. ASME, SERIES I, (DECEMBER, 1978).
- \*\*PLETCHER, RICHARD H., AND CLINTON L. DANCEY. "A DIRECT METHOD OF CALCULATING THROUGH SEPARATED REGIONS IN BOUNDARY LAYER FLOW", JOURNAL OF FLUIDS ENGINEERING, TRANS. ASME, SERIES I, SEPTEMBER, 1976, PP. 568-572.

- POWELL, A. LAMINAR INCOMPRESSIBLE JET FLOW FROM FREE JETS, CALIFORNIA UNIVERSITY, LOS ANGELES, PROCEEDINGS OF THE FLUID AMPLIFICATION SYMPOSIUM, OCTOBER 2-4, 1962, VOL. 1, NOVEMBER 15, 1962, PP. 289-299.
- POWELL, W.B., AND R.W. RIEBLING. THE HYDRAULIC CHARACTERISTICS OF FLOW THROUGH MINIATURE SLOT ORIFICES, AMERICAN INSTITUTE OF AERONAUTICS AND ASTRONAUTICS, PROPULSION JOINT SPECIALIST CONFERENCE, 6TH, SAN DIEGO, CALIFORNIA, JUNE 15-19, 1970.
- POZZI, A. "VISCOUS JETS FROM NONNARROW ORIFICES", AIAA JOURNAL, VOL. 2 MAY, 1964, PP. 949-951.
- PRANDTL, L. "INFLUENCE OF THE STABILIZING FORCES ON TURBULENCE", VORT. AUS D. GEB. D. AERODYN. U. VERM. GEBIETE, AACHEN, 1929. (BERLIN, 1930.) (GERMAN)
- PRANDTL, L. FLUID DYNAMIC THEORY, 3RD ED. (GERMAN)
- \*QUARMBY, A. "AN EXPERIMENTAL STUDY OF TURBULENT FLOW THROUGH CONCENTRIC ANNULI", INTERNATIONAL JOURNAL OF MECHANICAL SCIENCE, VOL. 9, NO. 4, 1967, PP. 205-221.
- RICHTER, H. PIPE HYDRAULICS, 3RD ED., SPRINGER, BERLIN, 1958. (GERMAN)
- \*\*RIEDY, J.P., AND C.R. SMITH. HEAT TRANSFER AND FLUID FLOW CHARACTERISTICS OF TRANSVERSE FINS, RESEARCH MEMO NO. 128, ALLISON DIVISION, GENERAL MOTORS CORP., INDIANAPOLIS, INDIANA, 1959.
- ROACHE, P.J. COMPUTATIONAL FLUID DYNAMICS, HERMOSA PUBLISHERS, ALBUQUERQUE, NEW MEXICO, 1972.
- ROACHE, PATRICK J. LECTURE NOTES IN MATHEMATICAL COMPUTATIONAL MECHANICS, VOL. 461, 1975, PP. 195-256.
- \*\*ROBINSON, C.S.L. "FLOW OF A COMPRESSIBLE FLUID THROUGH A SERIES OF IDENTICAL ORIFICES", JOURNAL OF APPLIED MECHANICS, TRANS. ASME, VOL. 70, NO. 15, DECEMBER, 1948, PP. 308-310.
- \*ROLLINS, JOHN P., ED. COMPRESSED AIR AND GAS HANDBOOK, FOURTH EDITION, COMPRESSED AIR AND GAS INSTITUTE, NEW YORK, 1973, PP. 3-62 TO 3-63.
- \*ROSHKO, A. SOME MEASUREMENTS OF FLOW IN A RECTANGULAR CUT-OUT, NACA TN 3488, 1955. (DDA 67-2471)
- RUBIN, S.G., EDITOR. NUMERICAL STUDIES OF INCOMPRESSIBLE VISCOUS FLOW IN A DRIVEN CAVITY, NASA SP378, 1975.
- RUPE, J.H. ON THE DYNAMIC CHARACTERISTICS OF FREE-LIQUID JETS AND A PARTIAL CORRELATION WITH ORIFICE GEOMETRY, JET PROPULSION LAB, CALIFORNIA INSTITUTE OF TECHNOLOGY, PASADENA, CALIFORNIA, JANUARY 15, 1962.
- RUPPEL, G. "INFLUENCE OF EXPANSION ON THE CONTRACTION BEHIND STAGNATION WHEELS", FORSCH. ING.-WES., VOL 1. (GERMAN)

- \*SAIY, M. "THE EFFECT OF FREE-STREAM TURBULENCE IN THE MIXING PROCESS", PROCEEDINGS OF THE 1977 TOKYO JOINT GAS TURBINE CONGRESS, MAY 22-27, 1977, PP. 363-369. (DISCUSSION: P. 370.) (DDA TJ778 T66)
- \*SAVAGE, S.B. "LAMINAR RADIAL FLOW BETWEEN PARALLEL PLATES", JOURNAL OF APPLIED MECHANICS, TRANS. ASME, SERIES E, VOL. 31, DECEMBER, 1964, PP. 594-596.
- SCHLICHTING, H. BOUNDARY LAYER THEORY, MCGRAW HILL CO., NEW YORK, 1960.
- \*SCHLICHTING, H. BOUNDARY LAYER THEORY, PERGAMON PRESS, NEW YORK, 1955. (DDA TL574 B6 S28)
- SCHNECKENBURG, E. FLOW OF WATER THROUGH CONCENTRIC AND ECCENTRIC CYLINDRICAL THROTTLING SLOTS WITH AND WITHOUT ANNULAR GROOVES, (DISSERTATION, TH AACHEN, 1929), ZEITSCHRIFT FUR ANGEWANDTE MATHEMATIK UND MECHANIK, VOL. 11, 1931, PP. 27-40. (GERMAN)
- SCHUBAUER, G.B., AND P.S. KLEBANOFF. CONTRIBUTIONS ON THE MECHANICS BOUNDARY-LAYER TRANSITION, NACA REPORT 1289, 1956.
- SCHUMACHER, W. "INVESTIGATION OF FLOWS IN NARROW SLOTS", ING. ARCH., VOL. 1, 1930, PP. 444-448. (GERMAN)
- \*SENUNAS, L. FLOW OF COMPRESSIBLE FLUID BETWEEN CLOSELY SPACED PARALLEL PLANES, REPORT NO. 35-1957, RESEARCH LABORATORIES, GENERAL MOTORS CORP., SEPTEMBER 20, 1962. (DDA 62-5109)
- SFORZA, P.M., AND H. VIETS. AN EXPERIMENTAL INVESTIGATION OF A TURBULENT, INCOMPRESSIBLE, THREE-DIMENSIONAL WALL JET, POLYTECHNIC INSTITUTE OF BROOKLYN, DEPT. OF AEROSPACE ENGINEERING AND APPLIED MATHEMATICS, FARMINGDALE, NEW YORK, NASA-CR-76454, APRIL, 1966.
- SHAPIRO, A.H. THE DYNAMICS AND THERMODYNAMICS OF COMPRESSIBLE FLUID FLOW, VOL. I, THE RONALD PRESS CO., NEW YORK, 1953. (DDA QA913 S49)
- SHAPIRO, A.H. SHAPE AND FLOW, THE FLUID DYNAMICS OF DRAG; ANCHOR, NEW YORK, 1961.
- SHIRES, G.L. THE VISCID FLOW OF AIR IN A NARROW SLOT, AERONAUTICAL RESEARCH COUNCIL CURRENT PAPER NO. 13, 1950, (123291).
- SIEDER, E.N., AND G.E. TATE. "HEAT TRANSFER AND PRESSURE DROP OF LIQUIDS IN TUBES", INDUSTRIAL ENGINEERING CHEMISTRY, VOL. 28, NO. 12, 1936, PP. 1429-1435.
- SOMERLING, H. "JET FLOW IN LIMITED SPACES", REVUE M DE LA MECANIQUE, VOL. 7, 1961, PP. 14-28. (GERMAN)
- SOMERLING, H. "STUDY OF PRESSURE VARIATION AND FLUID PROPAGATION IN FLOWS IN LIMITED SPACES", REVUE-C, 1961, PP. 205-212. (GERMAN)
- SOPER, W.G. FLOW OF LIQUID THROUGH MULTIPLE ORIFICES, NAVAL WEAPONS LAB, DAHLGREN, VIRGINIA, SEPTEMBER, 1967.

- \*SPARROW, E.M., AND S.H. LIN. "THE DEVELOPING LAMINAR FLOW AND PRESSURE DROP IN THE ENTRANCE REGION OF ANNULAR DUCTS", JOURNAL OF BASIC ENGINEERING, TRANS. ASME, SERIES D, VOL. 86, NO. 4, DECEMBER, 1965, PP. 827-834.
- \*SQUIRE, H.B. "NOTE ON THE MOTION INSIDE A REGION OF RECIRCULATION (CAVITY FLOW)", JOURNAL OF THE ROYAL AERONAUTICAL SOCIETY, VOL. 60, MARCH, 1956, PP. 203-205.
- SRINIVASAN, P.S. FRICTIONAL EFFECTS IN COILS, M. SC. THESIS UNIVERSITY OF SALFORD, U.K., 1968.
- STANTON, T.E., AND J.R. PANNELL. "SIMILARITY OF MOTION IN RELATION TO THE SURFACE FRICTION OF FLUIDS", TRANSACTIONS OF THE ROYAL SOCIETY OF LONDON, SERIES A, VOL. 214, 1914, P. 199.
- STEARNS, R.F., R.M. JACKSON, R.R. JOHNSON, AND C.A. LARSON. FLOW MEASUREMENT WITH ORIFICE METERS, D. VAN NOSTRAND CO., NEW YORK, 1951.
- STERLAND, P.R., AND M.A. HOLLINGSWORTH. "AN EXPERIMENTAL STUDY OF MULTIPLE JETS DIRECTED NORMALLY TO A CROSS-FLOW-FOR TURBOJET AFTERBURNING FLAMEHOLDER DESIGN", JOURNAL OF MECHANICAL ENGINEERING SCIENCE, VOL. 17, JUNE, 1975, PP. 117-124.
- STEVENS, S.J., U.S.L. NAYAK, AND G.J. WILLIAMS. "THE INFLUENCE OF INLE CONDITIONS ON THE PERFORMANCE OF ANNULAR DIFFUSERS", PROCEEDINGS OF THE JOINT SYMPOSIUM ON DESIGN AND OPERATION OF FLUID MACHINERY, VOL. 1, COLORADO STATE UNIV., FORT COLLINS, JUNE 12-14, 1978, PP. 277-290.
- STOFFEL, B. "THEORETICAL CALCULATION OF THE LAMINAR THROUGH-FLOW IN ECCENTRIC GAPS OF CENTRIFUGAL PUMPS FOR FLUIDS WITH TEMPERATURE-DEPENDENT VISCOSITY", PROCEEDINGS OF THE FIFTH CONFERENCE ON FLUID MACHINERY, VOL. 2, AKADEMIAI KIADO, BUDAPEST, HUNGARY, SEPTEMBER, 15-20, 1975, PP. 1097-1107.
- STROEHLER, R. "PRESSURE LOST IN FLOWING GASES", ARCH. WARMEW, VOL. 19, 1938, PP. 109-113. (GERMAN)
- STREETER, VICTOR L. HANDBOOK OF FLUID DYNAMICS, 1ST EDITION, MCGRAW-HILL, NEW YORK, 1961.
- STUNTZ, R.M. STUDY OF FLUID TRANSIENTS IN CLOSED CONDUITS INTERIM REPORT NO. 65-3, M.S. THESIS, OKLAHOMA STATE UNIVERSITY, STILLWATER, OKLAHOMA, APRIL 25, 1965.
- \*\*SUGGS, A.M. CALCULATION OF AIR FLOW THROUGH VARIOUS RESTRICTIONS, TDR AX1200-034, DETROIT DIESEL ALLISON, DIVISION OF GENERAL MOTORS CORP., INDIANAPOLIS, SEPTEMBER 5, 1969.
- SUZUKI, S. "ON THE LEAKAGE OF WATER IN CLEARANCE SPACES", JOURNAL OF THE FACULTY OF ENGINEERING, TOKYO IMPERIAL UNIVERSITY, VOL. 18, NO. 2, 1929.
- TAKAHAMA, H. STUDIES ON VORTEX TUBES, J.S.M.E., BULLETIN, VOL. 8, AUGUST, 1965, PP. 433-440.

- \*\*TAD, L.N. , AND W.F. DONOVAN. "THROUGH-FLOW IN CONCENTRIC AND ECCENTRIC ANNULI OF FINE CLEARANCE WITH AND WITHOUT RELATIVE MOTION OF THE BOUNDARIES". TRANS. ASME, VOL. 77, NO. 8, NOVEMBER, 1955, PP. 1291-1301.
- TAYLOR, G.I. "STABILITY OF A VISCOUS LIQUID CONTAINED BETWEEN TWO ROTATING CYLINDERS". PHILOSOPHICAL TRANSACTIONS OF THE ROYAL SOCIETY OF LONDON, SERIES A, VOL. 223, 1923, PP. 289-343.
- TAYLOR, G.I. "THE CRITERIA FOR TURBULENCE IN CURVED PIPES", PROCEEDINGS OF THE ROYAL SOCIETY OF LONDON, SERIES A, VOL. 124, 1929, PP. 243-249.
- TAYLOR, G.I. "FLUID FRICTION BETWEEN ROTATING CYLINDERS", PROCEEDINGS OF THE ROYAL SOCIETY OF LONDON, SERIES A, VOL. 157, 1936, PP. 546-564.
- TAYLOR, G.I., AND P.G. SAFFMAN. "THE EFFECTS OF THE COMPRESSIBILITY AT LOW REYNOLDS NUMBER", JOURNAL OF AERONAUTICAL SCIENCES, VOL. 24, NO. 8, AUGUST, 1957, PP. 553-562.
- \*TAYLOR, G.I. "CAVITATION OF A VISCOUS FLUID IN NARROW PASSAGES", JOURNAL OF FLUID MECHANICS, VOL. 16, NO. 4, 1963, PP. 595-619.
- TENNEKES, H., AND J.L. LUMLEY. A FIRST COURSE IN TURBULENCE, CAMBRIDGE AND LONDON, THE MIT PRESS, 1972.
- TEYSSANDIER, R.G. INTERNAL SEPARATED FLOWS EXPANSIONS, NOZZLES, AND ORIFICES. PH.D. THESIS, RHODE ISLAND UNIVERSITY, KINGSTON, RHODE ISLAND, 1973.
- \*THOM, A., AND C.J. APELT. THE PRESSURE IN A TWO-DIMENSIONAL STATIC HOLE AT LOW REYNOLDS NUMBER, ARC R & M 3090, VOL. 94, FEBRUARY, 1957, (HMSO 1958). (DDA 58-3304)
- TILLMAN, W. ADDITIONAL MEASUREMENTS OF THE DRAG OF SURFACE IRREGULARITIES IN TURBULENT BOUNDARY LAYERS, NACA TM 1299, JANUARY, 1951.
- \*\*TORIZUMI, YASUHIRO, NAOMICHI HIRAYAMA, AND TOSHIYUKI MAEDA. "METHODS OF LOSS ESTIMATION IN COMPRESSIBLE FLOW THROUGH PIPE ORIFICES AND NOZZLES", PAPER NO. 212-6, BULLETIN OF THE JAPANESE SOCIETY OF MECHANICAL ENGINEERS, VOL. 26, NO. 212, FEBRUARY, 1983, PP. 215-222.
- TRUTNOVSKY, KARL. "OCCURRENCE OF TRANSVERSE FORCES IN THE FLOW THROUGH SLOTS", VDI-ZEITSCHRIFT, VOL. 99, NO. 30, 1957, PP. 1538-1539. (GERMAN)
- \*\*ULVILA, E.A. "THREE STEPS FOR CALCULATING PRESSURE DROP", HYDRAULICS & PNEUMATICS, OCTOBER, 1981, PP. 173-176, 240.
- VIETS, H. "VISCOUS ENERGY TRANSFER FROM A LAMINAR THREE-DIMENSIONAL JET", INTERSOCIETY ENERGY CONVERSION ENGINEERING CONFERENCE, 7TH, SAN DIEGO, CALIFORNIA, SEPTEMBER 25-29, 1972, PROCEEDINGS, WASHINGTON, D.C., AMERICAN CHEMICAL SOCIETY, 1972, PP. 1178-1184.

- VIKTORIN, K. "INVESTIGATION OF TURBULENT MIXING PROCESSES", FORSCH. ING.-WES., VOL. 12, 1941, PP. 16-30. (GERMAN)
- VON DOENHOFF, ALBERT E., AND ELMER A. HORTON. A LOW-SPEED EXPERIMENTAL INVESTIGATION OF THE EFFECT OF A SANDPAPER TYPE ROUGHNESS ON BOUNDARY-LAYER TRANSITION, NACA REPORT 1349, LANGLEY AERONAUTICAL LABORATORY, LANGLEY FIELD, VIRGINIA, AUGUST, 1956.
- WARD-SMITH, A.J. "SUBSONIC ADIABATIC FLOW IN A DUCT OF CONSTANT CROSS-SECTIONAL AREA", JOURNAL OF THE ROYAL AERONAUTICAL SOCIETY, FEBRUARY, 1964.
- WARD-SMITH, A.J. SOME ASPECTS OF FLUID FLOW IN DUCTS, (PHD THESIS), UNIVERSITY OF OXFORD, UNITED KINGDOM, 1968.  
(PUBLISHED BY BUTTERWORTHS 1971)
- \*\*WARD-SMITH, A.J. PRESSURE LOSSES IN DUCTED FLOWS, BUTTERWORTHS, LONDON, ENGLAND, 1971.
- WARD-SMITH, A.J. "COMPONENT INTERACTIONS AND THEIR INFLUENCE ON THE PRESSURE LOSSES IN INTERNAL FLOW SYSTEMS", PROCEEDINGS OF THE INSTITUTION OF MECHANICAL ENGINEERS, VOL. 190, NO. 8/76, 1976.
- \*\*WARD-SMITH, A.J. INTERNAL FLUID FLOW, THE FLUID DYNAMICS OF FLOW IN PIPES AND DUCTS, CLARENDON PRESS, OXFORD, GREAT BRITAIN, 1980.
- \*WEISS, R.F., AND B.H. FLORSHEIM. "FLOW IN A CAVITY AT LOW REYNOLDS NUMBER", PHYSICS OF FLUIDS, VOL. 8, NO. 9, SEPTEMBER, 1965, PP. 1631-1635.
- WEISSENBERGER, E. FLOW THROUGH SLOT SEALS, (DISSERTATION), TH KARLSRUHE, 1952. (GERMAN)
- WHITE, C.M. "STREAMLINE FLOW THROUGH CURVED PIPES", PROCEEDINGS OF THE ROYAL SOCIETY OF LONDON, SERIES A, VOL. 123, 1929, PP. 645-663.
- WHITE, C.M. " FLUID FRICTION AND ITS RELATION TO HEAT TRANSFER", TRANSACTIONS OF THE INSTITUTION OF CHEMICAL ENGINEERS, VOL. 10, 1932, PP. 66-86.
- WINKEL, R. "WATER MOTION IN PIPES WITH RING SLOT FLOW CROSS-SECTION", Z. ANGEW. MATH. MECH., VOL. 3, 1923, PP. 251-257. (GERMAN)
- \*\*WYATT, DEMARQUIS D. ANALYSIS OF ERRORS INTRODUCED BY SEVERAL METHODS OF WEIGHTING NONUNIFORM DUCT FLOWS, NACA TN 3400, 1955.
- YAMADA, Y. "TORQUE AND PRESSURE DROP OF THE FLOW BETWEEN ROTATING COAXIAL CYLINDERS IN LOW REYNOLDS NUMBER", TRANS. JAP. SOC. MECH. ENGRS., VOL. 27, NO. 177, 1961, PP. 610-618. (JAPANESE)
- \*YAMADA, Y. "RESISTANCE OF A FLOW THROUGH AN ANNULUS WITH AN INNER ROTATING CYLINDER", BULLETIN OF JSME, VOL. 5, NO. 18, 1962, PP. 302-310.
- \*YAMADA, Y. "TORQUE RESISTANCE OF A FLOW BETWEEN ROTATING COAXIAL CYLINDERS HAVING AXIAL FLOW", BULLETIN OF JSME, VOL. 5, NO. 20, 1962, PP. 634-642.

- \*YAMADA, Y. "ON THE PRESSURE LOSS OF FLOW BETWEEN ROTATING COAXIAL CYLINDERS WITH RECTANGULAR GROOVES", BULLETIN OF JSME, VOL. 5, NO. 20, 1962, PP. 642-651.
- \*YAMADA, Y., AND K. NAKABAYASHI. "ON THE FLOW BETWEEN ECCENTRIC ROTATING CYLINDERS WHEN THE OUTER CYLINDER ROTATES", BULLETIN OF THE JSME, VOL. 11, NO. 45, 1968, PP. 445-462.
- ZAMPAGLIONE, D., AND M. GREPPI. "NUMERICAL STUDY OF A VISCOUS FLOW THROUGH A PIPE ORIFICE", MECCANICA, VOL. 7, SEPTEMBER, 1972, PP. 151-164.
- \*ZUK, JOHN, AND PATRICIA J. SMITH. COMPUTER PROGRAM FOR QUASI-ONE-DIMENSIONAL COMPRESSIBLE FLOW WITH AREA CHANGE AND FRICTION - APPLICATION TO GAS FILM SEALS, NASA TN D-7481, LEWIS RESEARCH CENTER, CLEVELAND, 1974. (DDA 75-732)

TOTAL NUMBER OF REFERENCES FOR THEORETICAL/EMPIRICAL ANALYSIS = 260

FLOW RESTRICTION LOSS FACTOR BIBLIOGRAPHY

LITERATURE SURVEYS

CLAIBORNE, H.C. A CRITICAL REVIEW OF THE LITERATURE ON PRESSURE DROP IN NONCIRCULAR DUCTS AND ANNULI, ORNL-1248, 1952.

CROW, D.A., AND R. WHARTON. "A REVIEW OF LITERATURE ON THE DIVISION AND COMBINATION OF FLOW IN CLOSED CONDUITS", TN 937, BRITISH HYDROMECHANICS RESEARCH ASSOCIATION, JANUARY, 1968.

DRYDEN, HUGH L. "REVIEW OF PUBLISHED DATA ON THE EFFECT OF ROUGHNESS ON TRANSITION FROM LAMINAR TO TURBULENT FLOW", JOURNAL OF AERONAUTICAL SCIENCES, VOL. 20, NO. 7, JULY, 1953, PP. 477-482.

GRAY S. A SURVEY OF EXISTING INFORMATION ON THE FLOW IN BENT CHANNELS AND THE LOSSES INVOLVED, POWER JETS REPORT NO. R. 1104, POWER JETS (RESEARCH AND DEVELOPMENT), JUNE, 1945.

TOTAL NUMBER OF REFERENCES FOR LITERATURE SURVEYS = 4

NOMENCLATURE

- a Small or minor dimension of a cross-section of a rectangular or elliptical duct, in.
- a Limiting  $\Phi$  of an orifice at  $r = 0$
- $A_n$  Area ratio,  $A_n/A_3$
- A Cross-sectional area of a duct, in.<sup>2</sup>
- $A_{ref}$  Real or defined reference area for a flow restriction, in.<sup>2</sup>
- b Large or major dimension of a cross-section of a rectangular or elliptical duct, in.
- $c_p$  Specific heat of the air at constant pressure, Btu/lbm deg R
- $c_v$  Specific heat of the air at constant volume, Btu/lbm deg R
- $C_a$  Angularity correction for obliquely incident flow into a restriction
- $C_A$  Area change correction for bends
- $C_c$  Contraction coefficient,  $A_c/A_n$
- $C_d$  Drag coefficient
- $C_D$  Discharge coefficient for a restriction,  $m/m_{id}$
- $C_f$  Frictional influence coefficient for aerodynamically rough wall
- $C_g$  Cross-sectional area geometry correction
- $C_1$  Influence coefficient for a general parameter which is different than that for the reference restriction
- $C_l$  Downstream tangent correction
- $C_M$  Compressibility influence coefficient for high velocity flow
- $C_r$  Edge break correction for a restriction area reduction
- $C_v$  Velocity coefficient for a restriction,  $V/V_{id}$
- d Diameter of a circular cross-section, or small diameter of an annular cross-sectional area of a duct, in.
- D Large diameter of an annular cross-sectional area of a duct, in.
- f Fanning friction factor for flow in straight ducts

NOMENCLATURE (con't)

|                |  |
|----------------|--|
| $f_c$          | Darcy-Weisback friction factor for flow in curved ducts  |
| $f( )$         | Functional relationship of independent variables ( )   |
| $F_d$          | Aerodynamic drag force, lbf  |
| $g_c$          | Conversion factor, 32.174 lbf ft/lbf sec <sup>2</sup>  |
| $h$            | Height (maximum) of a cross-section of a duct in the plane defined by radius $r$ normal to the bend axis ( $h$ can be the same as $a$ or $b$ of a rectangular or elliptical duct for example), in. |
| $D$            | Hydraulic diameter of a cross-section area of a duct, in.  |
| $k$            | Total pressure loss coefficient based on $q$   |
| $k^+$          | Total pressure loss coefficient based on $(P - p)$   |
| $k^*$          | Total pressure loss coefficient for the reference restriction (usually in the incompressible flow regime)  |
| $l$            | Length along the centerline of a duct, in.   |
| $m$            | Subscript slope of an orifice performance  |
| $\dot{m}$      | Mass flowrate, lbf/sec   |
| $\dot{m}_{id}$ | Ideal $\dot{m}$ which would pass through a lossless restriction if the available cross-sectional area flowed full, lbf/sec   |
| $M$            | Mach number  |
| $n$            | Supercritical constant for orifice performance   |
| $p$            | Static pressure of the air, psia   |
| $P$            | Total pressure of the air, psia  |
| $(P - p)$      | Impact pressure of the air, psia   |
| $P$            | Perimeter of a duct cross-sectional area, in.  |
| $q$            | Dynamic pressure of the air, psi   |
| $Q$            | Volumetric or mass flow ratio, $Q_n/Q_3$ or $m_n/m_3$  |
| $Q$            | Volume flowrate, ft <sup>3</sup> /sec  |
| $r$            | Radius of curvature for the centerline of a circular-arc bend, or edge break or fillet radii at tube-wall intersections, in.   |

NOMENCLATURE (con't)

|            |  |
|------------|--|
| $\alpha$   | Orifice pressure ratio, $P_0/P_U$  |
| $r$        | Radius of a circular cross-section, in.  |
| $r$        | Relative radius, $r/D$   |
| $r$        | Elliptical pressure ratio function for orifices, $1-r^2$                       |
| $R$        | Specific gas constant of the air, lbf ft/lbm deg R                             |
| $Re$       | Reynolds number  |
| $T$        | Total temperature of the air, deg R  |
| $V$        | Velocity of the air, ft/sec  |
| $V_{id}$   | Velocity of an isentropic one-dimensional flow filling the same area, ft/sec   |
| $x$        | Cartesian coordinate or an arbitrary geometrical variable                      |
| $y$        | Cartesian coordinate or an arbitrary geometrical variable                      |
| $\alpha$   | Turning loss term for bend k-factor equations                                  |
| $\beta$    | Complementary bend angle, degrees  |
| $\gamma$   | Ratio of specific heats of the air, $c_p/c_v$                                  |
| $\epsilon$ | Effective "sand grain" wall roughness, in.                                     |
| $\theta$   | Bend angle, degrees  |
| $\lambda$  | Sudden expansion area ratio, $A_1/A_2$   |
| $\Lambda$  | Sudden contraction area ratio, $A_2/A_1$ , or $A_1/A_0$ for profoces           |
| $\mu$      | Dynamic viscosity of the air, lbf/ft sec                                       |
| $\rho$     | Static density of the air, lbf/ft <sup>3</sup>                                 |
| $\Phi$     | Compressible flow parameter, $m \sqrt{T/P} A$ , lbf °R <sup>1/2</sup> /lbf sec |
| $\Phi$     | Elliptical flow parameter function for orifices, $\Phi^2$                      |

NOMENCLATURE (con't)

Superscripts

- Average or effective value of a nonconstant parameter
- \* Critical condition,  $M = 1.0$

Subscripts

- b Bend restriction
- c Fluid stream contraction due to separation at an abrupt flow area reduction, primarily a vena contracta
- d Downstream tangent duct
- D Downstream of a restriction
- e Restriction exit area component (discharge contribution)
- i Inside wall
- n General location in the internal flow system
- o Outside wall
- sc Sudden contraction restriction
- se Sudden expansion restriction
- u Upstream tangent duct
- U Upstream of a restriction
- v Velocity of the fluid stream
- 0 Free stream condition upstream of a flow obstacle
- 1 Inlet area of a flow restriction
- 2 Exit area of a flow restriction
- 3 Junction or branch leg carrying the combined flow

APPENDIX

Summary of Derivations

This Appendix contains the detailed calculations for:

Restriction 1--Orifice flow characteristics for a nozzle-like geometry. The Dodge (24) model was used to obtain k-factors for the DU1 program.

Restriction 2--Orifice flow characteristics for a thin-plate geometry. The Perry (29) model was used to develop the flow characteristic curve. The Dodge (24) model was used to obtain k-factors for the DU1 program.

The flow characteristic curve was converted to an overall k-factor curve (KURVE2) suitable for internal DU1 use, as demonstrated by the Restriction 7 calculation.

Restriction 3--The Dodge model was used to generate an orifice flow characteristic representative of the minimum component losses of Table VI. An "incompressible" flow slope of  $m = 0.317$  was found at  $r \sim 0.87$ . This yields a value of  $a = 0.544$  which exceeds the theoretical limit of  $a = 0.532$  for air. Therefore, the need to observe the overall slope limit,  $m < 0.26$ , in addition to the component loss limits is demonstrated.

Restriction 4--Provides a comparison of the static orifice curve calculated by the Dodge model with the test data correlation of Perry (29). The need for an alternative model for highly separated orifices can be seen from the flow characteristic discrepancy at high  $P_U/P_D$ .

Restriction 5--Demonstrates the use of a k-factor curve for the accurate representation of orifice performance in a DU1 restriction calculation. The CURVE1 example is for the static orifice of Perry (29).

Restriction 6--Demonstrates the rapid expansion of the vena contracta in high-speed compressible flow. It can be seen that  $l/D = 1.2$  is the theoretical limit for a Perry model of a static orifice.

Restriction 7--Verifies the equivalence of the k-factor curve (KURVE2) to the DU1 flow characteristic calculated for Restriction 2.

Restriction 8 (2k)--Demonstrates an imbedded k-factor curve (KURVE2) for a standard component within a more extensive flow characteristic model, w/  $T_U/P_U$  versus  $P_U/P_D$ , ( $A_n = \text{constant}$ , as modeled).

Restriction 8 (A\*)--Demonstrates the generalization of an extensive flow characteristic model (in this case, restriction 8(2K)) to all geometrically similar restrictions on the arbitrary basis of the minimum flow area,  $A_0$  (KURVE2).

Restriction 1: Generalized Thick-Wall Orifice Model

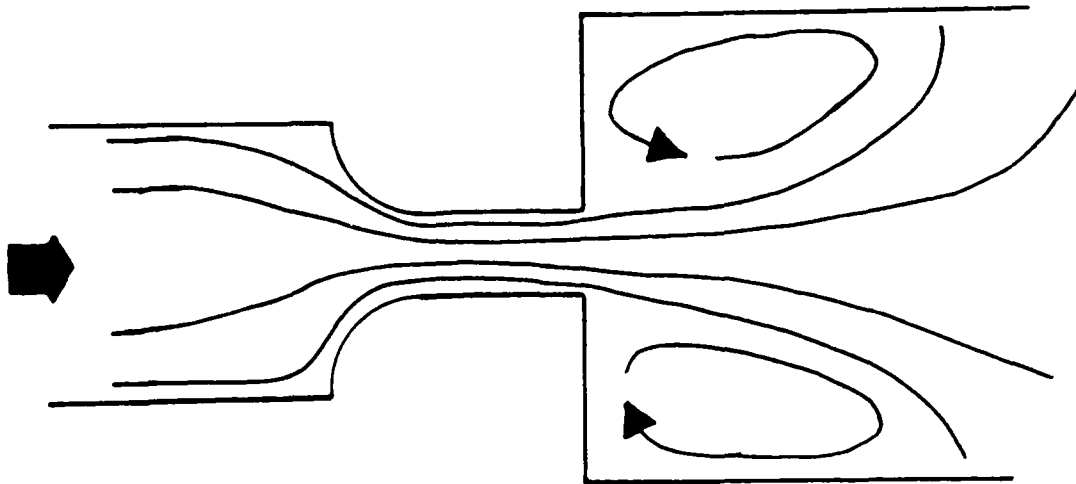

Given

- $A_0/A_1 = 6.0$  sudden contraction
- $r/D = 0.2$  rounded edge
- $l/D = 1.2$  orifice thickness
- $\epsilon/D = 1(10^{-4})$  wall roughness
- $A_2/A_1 = 30$ . Sudden expansion

Find compressible flow characteristic  $\gamma = 1.4$  and  $R = 53.342$  lbb ft/lbm °R

Dodge (24) incompressible flow model

$$K_{\theta} = k_{sc} + K_l + k_f + K_{se}$$

$$k_{sc}^* = 0.5$$

$$C_r = 0.06 \quad \text{Fig 21 } r/D = 0.2$$

$$K_l^* = 0.43 \quad \text{Fig 23 } l/D = 1.2$$



|           |                                    |           |
|-----------|------------------------------------|-----------|
| $P_u/P_D$ | 1.1177461                          | 1.1710073 |
| $\phi$    | 0.2323073                          | 0.2689874 |
| $\phi$    | 0.05397                            | 0.07235   |
|           | 0.19959                            | 0.27074   |
| $m$       | 0.27039 slightly exceeds $m_{max}$ | 0.26724   |
| $n$       | 0.26684                            | 0.26528   |
| $a$       | 0.50187                            | 0.49894   |
| $r^*$     | 0.52828                            | 0.52828   |
| $\phi^*$  | 0.44151                            | 0.43893   |

Restriction 2--Generalized Thin Wall Orifice Model

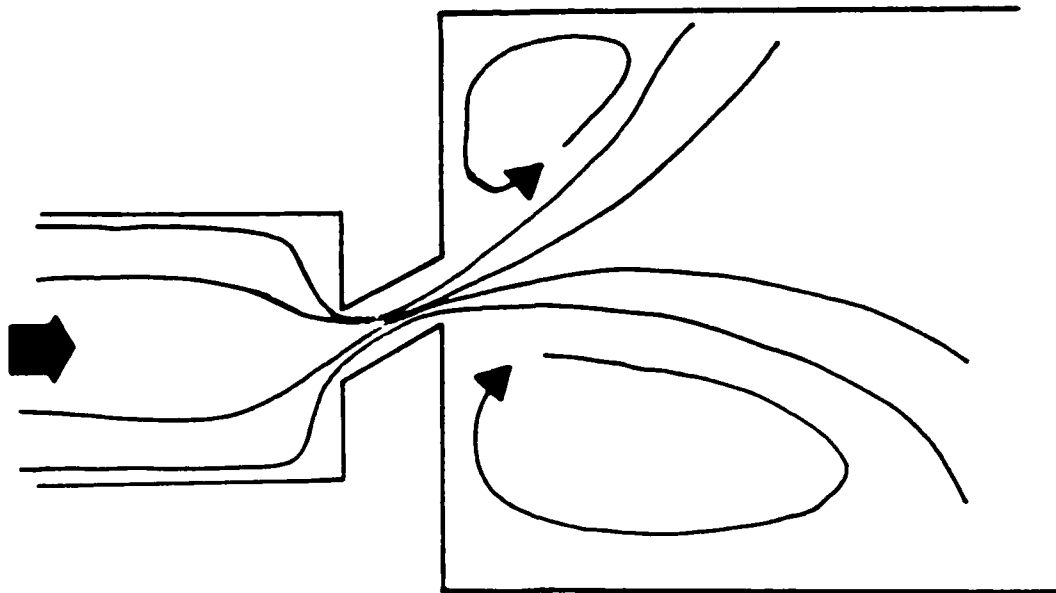

Given

- $A_0/A_1 = 6.0$  Sudden contraction
- $\theta = 45^\circ$  edge break,  $l_{sc}/D = 0.02$  ( $\alpha = 90^\circ$ )
- $\theta = 30^\circ$  hole angularity end wall approaching flow
- $l/D = 0.5$  orifice thickness
- $\epsilon/D = 1(10^{-4})$  wall roughness
- $A_2/A_1 = 10$ . Sudden expansion

Find

compressible flow characteristic for  $\gamma = 1.4$  and  $R = 53.342$  lbf ft/lbm °R

Dodge (24) incompressible flow model

$$k_{\theta} = k_{sc} + k_{\ell} + k_f + k_{se}$$

$$k_{sc}^* = 0.5$$

$$C_r = 0.85 \quad \text{Fig. 21} \quad \ell_{sc}/D = 0.02, \alpha = 90^\circ$$

$$C_{\alpha} = 1.35 \quad \text{Fig. 20} \quad \theta = 30^\circ \text{ Weisbach Eq.}$$

$$k_{\ell}^* = 1.00 \quad \text{Fig. 23} \quad \ell/D = 0.5$$

4f Moody correlation  $D = 0.35 \text{ in.}$   
 $\ell = 0.18 \text{ in.}$   
 $\epsilon = 30 \mu \text{ in.}$

$$\Lambda = A_1/A_0 = 0.167 \qquad \beta_1 = 0.408$$

$$\lambda = A_1/A_2 = 0.100 \qquad \beta_2 = 0.316$$

Sudden contraction

$$\begin{aligned}
 k_{sc} &= [C_{\alpha} C_r k_{sc}^*] [1 - \Lambda] \\
 &= 1.35 (0.85) 0.5 [0.833] \\
 &= 0.478 \qquad (> 0.4)
 \end{aligned}$$

Vena contracta

$$\begin{aligned}
 k_{\ell} &= (C_{\alpha} C_r)^{1/2} k_{sc}^* [1 - \Lambda]^{1/2} [1 - \lambda] \\
 &= (1.071) 1.00 [0.913] [0.900] \\
 &= 0.880 \qquad (< 0.65)
 \end{aligned}$$

Wall friction

$$k_f = 4f (\ell/D) \qquad \text{Internal calculation}$$

Sudden expansion

$$k_{se} = [1 - \lambda]^2 \qquad (\lambda < 0.125)$$

Slope

$$m = \Phi / \text{near } P_u/P_D \leq 1.15$$

RES2—SIMULATION OF A GENERALIZED ORIFICE COMPRESSIBLE FLOW - L/D = 0.5,  
EDGE-BREAK PERRY MODEL BASED ON DODGE "INCOMPRESSIBLE" PERFORMANCE FOR AIR

| $P_u/P_D$ | $m_r = 0.2674$ | $\beta = 0.2654$ | $M_\theta$ | $a = 0.4991$<br>$q/P$ | $k\theta$ |
|-----------|----------------|------------------|------------|-----------------------|-----------|
| 1.00      | 1.0000         | 0                | 0          | 0                     | 2.255     |
| 1.00363   | 0.99638        | 0.4394           | 0.4788     | 0.00160               | 2.25726   |
| 1.01780   | 0.98251        | 0.09629          | 0.10549    | 0.00773               | 2.26281   |
| 1.04161   | 0.96005        | 0.14470          | 0.15989    | 0.01758               | 2.27240   |
| 1.07493   | 0.93029        | 0.18968          | 0.21203    | 0.03050               | 2.28549   |
| 1.11775   | 0.89465        | 0.23102          | 0.26189    | 0.04577               | 2.30139   |
| 1.23561   | 0.80932        | 0.30373          | 0.35636    | 0.08142               | 2.34192   |
| 1.31332   | 0.76143        | 0.33521          | 0.40115    | 0.10082               | 2.34192   |
| 1.40726   | 0.71060        | 0.36383          | 0.44482    | 0.12091               | 2.39348   |
| 1.52107   | 0.65743        | 0.38965          | 0.48738    | 0.14134               | 2.42366   |
| 1.66159   | 0.60183        | 0.41297          | 0.52924    | 0.16201               | 2.45762   |
| 1.86193   | 0.53708        | 0.43620          | 0.57534    | 0.18514               | 2.50037   |
| 1.89293   | 0.52828        | 0.43906          | 0.58140    | 0.18820               | 2.50654   |
| 2.11115   | 0.47368        | 0.45326          | 0.61304    | 0.20413               | 2.57833   |
| 2.3       | 0.43478        | 0.46195          | 0.63391    | 0.21461               | 2.62267   |
| 2.5       | 0.40000        | 0.46881          | 0.65138    | 0.22334               | 2.68652   |
| 3.0       | 0.33333        | 0.47972          | 0.68140    | 0.23819               | 2.79890   |
| 3.5       | 0.28571        | 0.48588          | 0.69985    | 0.24720               | 2.88946   |
| 4.0       | 0.25000        | 0.48967          | 0.71187    | 0.25302               | 2.96419   |
| 5.0       | 0.20000        | 0.49386          | 0.72585    | 0.25972               | 3.08019   |
| 7.0       | 0.14286        | 0.49716          | 0.73746    | 0.26523               | 3.23165   |
| 10.0      | 0.10000        | 0.49865          | 0.74289    | 0.26780               | 3.36077   |
| 20.0      | 0.05000        | 0.49938          | 0.74560    | 0.26907               | 3.35070   |
| 100.0     | 0.01000        | 0.49922          | 0.74501    | 0.26879               | 3.68319   |
| 1000.0    | 0.00010        | 0.49908          | 0.74449    | 0.26854               | 3.72341   |

INPUT DATASET D D A

|           |   |           |           |           |           |           |           |  |
|-----------|---|-----------|-----------|-----------|-----------|-----------|-----------|--|
| KURVE     | 1 | 20        |           |           |           |           |           |  |
| 0.0       |   | 0.0328    | 0.0653    | 0.0925    | 0.1302    | 0.1586    | 0.1823    |  |
| 0.2027    |   | 0.2460    | 0.2790    | 0.3080    | 0.3320    | 0.3540    | 0.3730    |  |
| 0.3890    |   | 0.4030    | 0.4230    | 0.4360    | 0.4440    | 0.4490    |           |  |
| 2.7940000 |   | 2.7940068 | 2.7940844 | 2.8042504 | 2.8195665 | 2.8322270 | 2.8460312 |  |
| 2.8611360 |   | 2.8760168 | 2.9434909 | 2.9794882 | 3.0389848 | 3.0776563 | 3.1275657 |  |
| 3.1960778 |   | 3.2702482 | 3.4953703 | 3.7851911 | 4.1324977 | 4.7688857 |           |  |
| KURVE     | 2 | 20        |           |           |           |           |           |  |
| 0.0       |   | 0.04394   | 0.09629   | 0.14470   | 0.18968   | 0.23102   | 0.26907   |  |
| 0.30373   |   | 0.33521   | 0.36383   | 0.38965   | 0.41297   | 0.43906   | 0.45326   |  |
| 0.46195   |   | 0.46881   | 0.47972   | 0.48588   | 0.49386   | 0.49908   |           |  |
| 2.25500   |   | 2.25726   | 2.26281   | 2.27240   | 2.28549   | 2.30139   | 2.32019   |  |
| 2.34192   |   | 2.36623   | 2.39348   | 2.42366   | 2.45762   | 2.50654   | 2.57833   |  |
| 2.63367   |   | 2.68652   | 2.79890   | 2.88946   | 3.08019   | 3.72341   |           |  |

RES 1 1 SIMULATION OF A GENERALIZED ORIFICE COMPRESSIBLE FLOW 24APR86  
 BASED ON THE DODGE MODEL - L/D = 1.2, LEADING EDGE RADIUS PLOT  
 5 0.10 1.40 28.97  
 0.60 540.  
 0.10 540. 0.025 Q  
 0.10 540. 0.093 Q  
 0.10 540. 0.42 0.35 30.  
 3.00 540. 0.934 PT  
 125.

RES 2 2 SIMULATION OF A GENERALIZED ORIFICE COMPRESSIBLE FLOW 24APR86  
 BASED ON THE DODGE MODEL - L/D = .5, EDGE BREAK, OBLIQUE ANGLE PLOT  
 5 0.10 1.40 28.97  
 0.60 540.  
 0.10 540. 0.478 Q  
 0.10 540. 0.880 Q  
 0.10 540. 0.18 0.35 30.  
 1.00 540. 0.810 PT  
 125.

RES 3 3 SIMULATION OF A COMPRESSIBLE FLOW STATIC ORIFICE GFH 24APR86  
 LIMIT OF THE DODGE MODEL -- TABLE VI COMPONENT LOSSES PLOT  
 5 1.0 1.40 28.97  
 1000. 100.  
 1.00 100. 0.40 Q  
 1.00 100. 0.65 Q  
 1.00 100. 0.0 PT  
 1000. 100. 0.766  
 10.0 10.0

RES 4 4 SIMULATION OF A COMPRESSIBLE FLOW STATIC ORIFICE GFH 24APR86  
 BASED ON PERRY EMPIRICAL DATA AND DODGE INCOMPRESSIBLE MODEL PLOT  
 5 1.0 1.40 28.97  
 1000. 100.  
 1.00 100. 0.50 Q  
 1.00 100. 1.34 Q  
 1.00 100. 0.0 PT  
 1000. 100. 1.0  
 10.0 10.0

RES 5 5 STATIC ORIFICE RESTRICTION IN COMPRESSIBLE FLOW GFH 24APR86  
 BASED ON THE K-FACTOR DATA TABLE FOR EMPIRICAL PERRY MODEL PLOT  
 4 1.0 1.40 28.97  
 10.000 100.  
 1.0000 100.  
 1.0000 100.  
 10.000 100. 1 Q  
 10.000 10.

RES 6 6 SIMULATION OF A COMPRESSIBLE FLOW STATIC ORIFICE GFH 24APR86  
 LIMIT OF THE DODGE MODEL -- L/D = 1.2 PLOT  
 5 1.0 1.40 28.97  
 1000. 100.  
 1.00 100. 0.50 Q  
 1.00 100. 0.43 Q  
 1.00 100. 0.024

|           |  |       |       |    |               |
|-----------|--|-------|-------|----|---------------|
| 1000.     | 100.   | 1.0   |       | PT |               |
|           | 10.0   |       |       |    |               |
|           | 7  |       |       |    |               |
| RES 7(2K) | SIMULATION OF A GENERALIZED ORIFICE COMPRESSIBLE FLOW          |       |       |    | 24APR86       |
|           | BASED ON THE DODGE MODEL - L/D = .5, EDGE BREAK, OBLIQUE ANGLE |       |       |    |               |
| 4         | 0.10   | 1.40  | 28.97 |    | PLOT          |
| 0.60      | 540.   |       |       |    |               |
| 0.10      | 540.   |       |       |    |               |
| 0.10      | 540.   |       |       | 2  | Q             |
| 1.00      | 540.   |       |       |    |               |
|           | 125.   |       |       |    |               |
|           | 8  |       |       |    |               |
| RES 8(2K) | COMPLEX RESTRICTION MODEL INCLUDING GENERALIZED ORIFICE RES 2  |       |       |    |               |
|           | BASED ON THE DODGE MODEL - L/D = .5, EDGE BREAK, OBLIQUE ANGLE |       |       |    |               |
| 8         | 1.00   | 1.40  | 28.97 |    | PLOT          |
| 1000.     | 600.   |       |       |    |               |
| 1.00      | 600.   | 0.578 |       |    | Q             |
| 1.00      | 580.   |       |       |    | 5.50 1.12850. |
| 0.60      | 540.   | 0.050 |       |    | Q             |
| 0.10      | 540.   |       |       | 2  | Q             |
| 1.00      | 540.   |       |       |    |               |
| 1.00      | 520.   |       |       |    | 3.00 1.12850. |
| 1000.     | 500.   | 1.0   |       |    | PT            |
|           | 125.   |       |       |    |               |
|           | 9  |       |       |    |               |
| RES 8(A#) | COMPLEX RESTRICTION MODEL INCLUDING GENERALIZED ORIFICE RES 2  |       |       |    |               |
|           | BASED ON THE DODGE MODEL - L/D = .5, EDGE BREAK, OBLIQUE ANGLE |       |       |    |               |
| 8         | 0.10   | 1.40  | 28.97 |    | PLOT          |
| 1000.     | 600.   |       |       |    |               |
| 1.00      | 600.   | 0.578 |       |    | Q             |
| 1.00      | 580.   |       |       |    | 5.50 1.12850. |
| 0.60      | 540.   | 0.050 |       |    | Q             |
| 0.10      | 540.   |       |       | 2  | Q             |
| 1.00      | 540.   |       |       |    |               |
| 1.00      | 520.   |       |       |    | 3.00 1.12850. |
| 1000.     | 500.   | 1.0   |       |    | PT            |
|           | 125.   |       |       |    |               |

CURVE NUMBER 1  
 RES 1 SIMULATION OF A GENERALIZED ORIFICE COMPRESSIBLE FLOW 24APR86  
 BASED ON THE DODGE MODEL - L/D = 1.2, LEADING EDGE RADIUS

NUMBER OF ITERATIONS = 23  
 W= 0.27315 LBS/SEC GAMMA= 1.40 MH=28.97 LB/LB-MOL

| STN | AREA    | TT(I)  | MRT/PTA | MRT/PSA | 4FL/D | KFACT | KURVE | PT      | PS      | MN    | KFACT METH | PIN ROMS | LENGTH | HD     | ROUGH |
|-----|---------|--------|---------|---------|-------|-------|-------|---------|---------|-------|------------|----------|--------|--------|-------|
| 1   | 0.60000 | 540.00 | 0.0846  | 0.0851  | 0.0   | 0.0   | 0     | 125.000 | 124.253 | 0.093 |            | 0        | 0.0    | 0.0    | 0.0   |
| 2   | 0.10000 | 540.00 | 0.5114  | 0.7767  | 0.0   | 0.025 | 0     | 124.110 | 81.723  | 0.796 | Q          | 0        | 0.0    | 0.0    | 0.0   |
| 3   | 0.10000 | 540.00 | 0.5257  | 0.8762  | 0.0   | 0.093 | 0     | 120.737 | 72.442  | 0.886 | Q          | 0        | 0.0    | 0.0    | 0.0   |
| 4   | 0.10000 | 540.00 | 0.5318  | 1.0063  | 0.019 | 0.0   | 0     | 119.859 | 63.074  | 1.000 |            | 0        | 0.4200 | 0.3500 | 30.0  |
| 5   | 3.00000 | 540.00 | 0.0317  | 0.0317  | 0.0   | 0.934 | 0     | 66.789  | 66.734  | 0.034 | PT-PS      | 0        | 0.0    | 0.0    | 0.0   |

# OVERALL CONDITIONS #  
 PTIN/PTEX PTIN/PSEX MRTIN/PTIN MRTIN/PSIN PTI-PTE/PTI PTI-PSE/PTI  
 1.8716 1.8731 0.05078 0.05108 0.4657 0.4661  
 END OF CHOKE POINT CALCULATION

FLOW CURVE CALCULATED BY DUI  
 CURVE POINTS 14 AREF .100000

RES 1 SIMULATION OF A GENERALIZED ORIFICE COMPRESSIBLE FLOW 24APR86  
 PR 1.00000 1.00281 1.01361 1.03174 1.05681 1.08095 1.12036 1.17620 1.23344 1.30201 1.38397 1.49301 1.64968 1.87156  
 PHI 0.0 0.05586 0.12187 0.18281 0.23866 0.28944 0.33815 0.37577 0.41132 0.44178 0.46717 0.48748 0.50272 0.50780

CURVE NUMBER 2  
 RES 2 SIMULATION OF A GENERALIZED ORIFICE COMPRESSIBLE FLOW 24APR86  
 BASED ON THE DODGE MODEL - L/D = .5, EDGE BREAK, OBLIQUE ANGLE

NUMBER OF ITERATIONS = 24  
 W= 0.21923 LBS/SEC GAMMA= 1.40 MH=28.97 LB/LB-MOL

| STN | AREA    | TT(I)  | MRT/PTA | MRT/PSA | 4FL/D | KFACT | KURVE | PT      | PS      | MN    | KFACT METH | PIN ROMS | LENGTH | HD     | ROUGH |
|-----|---------|--------|---------|---------|-------|-------|-------|---------|---------|-------|------------|----------|--------|--------|-------|
| 1   | 0.60000 | 540.00 | 0.0679  | 0.0682  | 0.0   | 0.0   | 0     | 125.000 | 124.520 | 0.074 |            | 0        | 0.0    | 0.0    | 0.0   |
| 2   | 0.10000 | 540.00 | 0.4406  | 0.5554  | 0.0   | 0.478 | 0     | 115.619 | 91.724  | 0.585 | Q          | 0        | 0.0    | 0.0    | 0.0   |
| 3   | 0.10000 | 540.00 | 0.5290  | 0.9170  | 0.0   | 0.880 | 0     | 96.300  | 55.554  | 0.922 | Q          | 0        | 0.0    | 0.0    | 0.0   |
| 4   | 0.10000 | 540.00 | 0.5318  | 1.0063  | 0.008 | 0.0   | 0     | 95.797  | 50.627  | 1.000 |            | 0        | 0.1800 | 0.3500 | 30.0  |
| 5   | 1.00000 | 540.00 | 0.0860  | 0.0866  | 0.0   | 0.810 | 0     | 59.210  | 58.844  | 0.094 | PT-PS      | 0        | 0.0    | 0.0    | 0.0   |

# OVERALL CONDITIONS #  
 PTIN/PTEX PTIN/PSEX MRTIN/PTIN MRTIN/PSIN PTI-PTE/PTI PTI-PSE/PTI  
 2.1111 2.1243 0.01076 0.04091 0.5263 0.5292  
 END OF CHOKE POINT CALCULATION

FLOW CURVE CALCULATED BY DUI  
 CURVE POINTS 14 AREF .100000

RES 2 SIMULATION OF A GENERALIZED ORIFICE COMPRESSIBLE FLOW 24APR86  
 PR 1.00000 1.00363 1.01780 1.04161 1.07493 1.11775 1.17101 1.23561 1.31332 1.40726 1.52107 1.66159 1.86193 2.11115  
 PHI 0.0 0.04483 0.09781 0.14672 0.19155 0.23231 0.26899 0.30159 0.33012 0.35457 0.37495 0.39125 0.40348 0.40756

CURVE NUMBER 3

RES 3 SIMULATION OF A COMPRESSIBLE FLOW STATIC ORIFICE GFH 24APR86  
LIMIT OF THE DODGE MODEL -- TABLE VI COMPONENT LOSSES

NUMBER OF ITERATIONS = 23

W= 0.42672 LBS/SEC GAMMA= 1.40 MH=28.97 LB/LB-MOL

| STM | AREA       | TT(I)  | WRT/PSA | 4FL/D | KFACT | KURVE | PT     | PS     | MN    | KFACT METH | PIN ROWS | LENGTH | HD  | ROUGH |
|-----|------------|--------|---------|-------|-------|-------|--------|--------|-------|------------|----------|--------|-----|-------|
| 1   | 1000.00000 | 100.00 | 0.0004  | 0.0   | 0.0   | 0     | 10.000 | 10.000 | 0.000 |            | 0        | 0.0    | 0.0 | 0.0   |
| 2   | 1.00000    | 100.00 | 0.4589  | 0.0   | 0.400 | 0     | 9.299  | 7.138  | 0.626 | Q          | 0        | 0.0    | 0.0 | 0.0   |
| 3   | 1.00000    | 100.00 | 0.5318  | 0.0   | 0.650 | 0     | 8.024  | 4.241  | 1.000 | Q          | 0        | 0.0    | 0.0 | 0.0   |
| 4   | 1.00000    | 100.00 | 0.5318  | 0.0   | 0.0   | 0     | 8.024  | 4.241  | 1.000 |            | 0        | 0.0    | 0.0 | 0.0   |
| 5   | 1000.00000 | 100.00 | 0.0008  | 0.0   | 0.766 | 0     | 5.126  | 5.126  | 0.001 | PT-PS      | 0        | 0.0    | 0.0 | 0.0   |

\* OVERALL CONDITIONS \*

PTIN/PTEX PTIN/PSEX WRTIN/PTIN WRTIN/PSIN PTI-PTE/PTI PTI-PSE/PTI  
1.9508 1.9508 0.42672 0.42672 0.4874 0.4874

FLOW CURVE CALCULATED BY DU1

CURVE POINTS 14  
AREF 1.00000

RES 3 SIMULATION OF A COMPRESSIBLE FLOW STATIC ORIFICE GFH 24APR86  
PHI 0.0 1.00334 1.91625 1.03793 1.06816 1.10179 1.13947 1.17129 1.20997 1.25097 1.28997 1.36284 1.46133 1.58299 1.74921 1.99970  
0.0 0.04694 0.10241 0.15362 0.20956 0.24523 0.28168 0.31577 0.34564 0.37124 0.39258 0.40965 0.42845 0.42672

END OF CHOKE POINT CALCULATION

CURVE NUMBER 4

RES 4 SIMULATION OF A COMPRESSIBLE FLOW STATIC ORIFICE GFH 24APR86  
BASED ON PERRY EMPIRICAL DATA AND DODGE INCOMPRESSIBLE MODEL

NUMBER OF ITERATIONS = 24

W= 0.38625 LBS/SEC GAMMA= 1.40 MH=28.97 LB/LB-MOL

| STM | AREA       | TT(I)  | WRT/PSA | 4FL/D | KFACT | KURVE | PT     | PS     | MN    | KFACT METH | PIN ROWS | LENGTH | HD  | ROUGH |
|-----|------------|--------|---------|-------|-------|-------|--------|--------|-------|------------|----------|--------|-----|-------|
| 1   | 1000.00000 | 100.00 | 0.0004  | 0.0   | 0.0   | 0     | 10.000 | 10.000 | 0.000 |            | 0        | 0.0    | 0.0 | 0.0   |
| 2   | 1.00000    | 100.00 | 0.4150  | 0.0   | 0.500 | 0     | 9.307  | 7.678  | 0.533 | Q          | 0        | 0.0    | 0.0 | 0.0   |
| 3   | 1.00000    | 100.00 | 0.5318  | 0.0   | 1.340 | 0     | 7.263  | 3.839  | 1.000 | Q          | 0        | 0.0    | 0.0 | 0.0   |
| 4   | 1.00000    | 100.00 | 0.5318  | 0.0   | 0.0   | 0     | 7.263  | 3.839  | 1.000 |            | 0        | 0.0    | 0.0 | 0.0   |
| 5   | 1000.00000 | 100.00 | 0.0010  | 0.0   | 1.000 | 0     | 3.839  | 3.839  | 0.001 | PT-PS      | 0        | 0.0    | 0.0 | 0.0   |

\* OVERALL CONDITIONS \*

PTIN/PTEX PTIN/PSEX WRTIN/PTIN WRTIN/PSIN PTI-PTE/PTI PTI-PSE/PTI  
2.6048 2.6048 0.38625 0.38625 0.6161 0.6161

FLOW CURVE CALCULATED BY DU1

CURVE POINTS 14  
AREF 1.00000

RES 4 SIMULATION OF A COMPRESSIBLE FLOW STATIC ORIFICE GFH 24APR86  
PHI 0.0 1.00428 1.02091 1.04910 1.08892 1.14079 1.20619 1.28756 1.38777 1.51227 1.66906 1.87249 2.18351 2.60475  
0.0 0.04249 0.09270 0.13905 0.18154 0.22016 0.25493 0.28583 0.31286 0.33604 0.35535 0.37080 0.38239 0.38625

END OF CHOKE POINT CALCULATION

CURVE NUMBER 5  
RES 5 STATIC ORIFICE RESTRICTION IN COMPRESSIBLE FLOW GFH 26APR86  
BASED ON THE K-FACTOR DATA TABLE FOR EMPIRICAL PERRY MODEL

NUMBER OF ITERATIONS = 24

W= 0.35036 LBS/SEC GAMMA= 1.40 MW=28.97 LB/LB-MOL

| STN | AREA     | TT(I)  | WRT/PTA | WRT/PSA | 4FL/D | KFACT | KURVE | PT     | PS    | MN    | KFACT METH | PIN ROWS | LENGTH | HD  | ROUGH |
|-----|----------|--------|---------|---------|-------|-------|-------|--------|-------|-------|------------|----------|--------|-----|-------|
| 1   | 10.00000 | 100.00 | 0.0350  | 0.0351  | 0.0   | 0.0   | 0     | 10.000 | 9.090 | 0.038 | Q          | 0        | 0.0    | 0.0 | 0.0   |
| 2   | 1.00000  | 100.00 | 0.3064  | 0.3064  | 0.0   | 0.0   | 0     | 10.000 | 8.838 | 0.424 | Q          | 0        | 0.0    | 0.0 | 0.0   |
| 3   | 1.00000  | 100.00 | 0.5318  | 1.0050  | 0.0   | 3.070 | 1     | 6.588  | 3.482 | 0.999 | Q          | 0        | 0.0    | 0.0 | 0.0   |
| 4   | 10.00000 | 100.00 | 0.0532  | 0.0533  | 0.0   | 0.0   | 0     | 6.588  | 6.573 | 0.058 | Q          | 0        | 0.0    | 0.0 | 0.0   |

\* OVERALL CONDITIONS \*

PTIN/PTEX 1.5179 PTIN/PSEX 1.5214 WRTIN/PTIN 0.35036 WRTIN/PSIN 0.35071 PFI-PTE/PTI 0.3412 PFI-PSE/PTI 0.3427

END OF CHOKE POINT CALCULATION

FLOW CURVE CALCULATED BY DUI

CURVE POINTS 14 1.00000

RES 5 STATIC ORIFICE RESTRICTION IN COMPRESSIBLE FLOW GFH 26APR86  
PR 1.00000 1.00345 1.01676 1.03895 1.06929 1.10728 1.15093 1.20330 1.26181 1.32239 1.38688 1.46659 1.49764 1.58787  
PHI 0.0 0.03854 0.08469 0.12613 0.16467 0.19970 0.23124 0.25926 0.28379 0.30481 0.32233 0.33634 0.34685 0.35936

CURVE NUMBER 6

RES 6 SIMULATION OF A COMPRESSIBLE FLOW STATIC ORIFICE GFH 26APR86  
LIMIT OF THE DODGE MODEL -- L/D = 1.2  
FOR STATION 4 TEMP SHOULD NOT BE 100. FOR FRICTION CALC  
FOR STATION 1 PRESSURE SHOULD NOT BE 10. FOR FRICTION CALC

NUMBER OF ITERATIONS = 23

W= 0.43047 LBS/SEC GAMMA= 1.40 MW=28.97 LB/LB-MOL

| STN | AREA       | TT(I)  | WRT/PTA | WRT/PSA | 4FL/D | KFACT | KURVE | PT     | PS     | MN    | KFACT METH | PIN ROWS | LENGTH | HD  | ROUGH |
|-----|------------|--------|---------|---------|-------|-------|-------|--------|--------|-------|------------|----------|--------|-----|-------|
| 1   | 1000.00000 | 100.00 | 0.0004  | 0.0004  | 0.0   | 0.0   | 0     | 10.000 | 10.000 | 0.000 | Q          | 0        | 0.0    | 0.0 | 0.0   |
| 2   | 1.00000    | 100.00 | 0.4728  | 0.6345  | 0.0   | 0.500 | 0     | 9.104  | 6.784  | 0.652 | Q          | 0        | 0.0    | 0.0 | 0.0   |
| 3   | 1.00000    | 100.00 | 0.5266  | 0.8632  | 0.0   | 0.430 | 0     | 8.209  | 4.987  | 0.875 | Q          | 0        | 0.0    | 0.0 | 0.0   |
| 4   | 1.00000    | 100.00 | 0.5318  | 1.0058  | 0.024 | 0.0   | 0     | 8.095  | 4.280  | 0.999 | Q          | 0        | 0.0    | 0.0 | 0.0   |
| 5   | 1000.00000 | 100.00 | 0.0010  | 0.0010  | 0.0   | 1.000 | 0     | 4.280  | 4.280  | 0.001 | PT-PS      | 0        | 0.0    | 0.0 | 0.0   |

\* OVERALL CONDITIONS \*

PTIN/PTEX 2.3366 PTIN/PSEX 2.3366 WRTIN/PTIN 0.43047 WRTIN/PSIN 0.43047 PFI-PTE/PTI 0.5720 PFI-PSE/PTI 0.5720

END OF CHOKE POINT CALCULATION

FLOW CURVE CALCULATED BY DUI

CURVE POINTS 6 14 1.00000

RES 6 SIMULATION OF A COMPRESSIBLE FLOW STATIC ORIFICE GFH 26APR86  
PR 1.00000 1.00351 1.01787 1.04180 1.07541 1.11888 1.17356 1.24066 1.32274 1.42379 1.55034 1.71625 1.96955 2.33660  
PHI 0.0 0.04735 0.10331 0.15497 0.20232 0.24537 0.28411 0.31855 0.34868 0.37451 0.39603 0.41325 0.42816 0.43047

CURVE NUMBER 7

RES 712K) SIMULATION OF A GENERALIZED ORIFICE COMPRESSIBLE FLOW 24APR86  
 BASED ON THE DODGE MODEL - L/D = .5, EDGE BREAK, OBLIQUE ANGLE

NUMBER OF ITERATIONS = 24

W= 0.19943 LBS/SEC GAMMA= 1.40 MW=28.97 LB/LB-MOL

| STN | AREA    | TT(I)  | WRT/PTA | WRT/PSA | 4FL/D | KFACT | KURVE | PT      | PS      | MN    | KFACT<br>METH | PIN<br>ROWS | LENGTH | MD  | ROUGH |
|-----|---------|--------|---------|---------|-------|-------|-------|---------|---------|-------|---------------|-------------|--------|-----|-------|
| 1   | 0.60000 | 540.00 | 0.0618  | 0.0620  | 0.0   | 0.0   | 0     | 125.000 | 124.603 | 0.067 |               | 0           | 0.0    | 0.0 | 0.0   |
| 2   | 0.10000 | 540.00 | 0.3707  | 0.4275  | 0.0   | 0.0   | 0     | 125.000 | 108.308 | 0.266 |               | 0           | 0.0    | 0.0 | 0.0   |
| 3   | 0.10000 | 540.00 | 0.5318  | 1.0053  | 0.0   | 2.401 | 2     | 87.144  | 46.052  | 1.000 | Q             | 0           | 0.0    | 0.0 | 0.0   |
| 4   | 1.00000 | 540.00 | 0.0532  | 0.0533  | 0.0   | 0.0   | 0     | 87.144  | 86.939  | 0.058 |               | 0           | 0.0    | 0.0 | 0.0   |

\* OVERALL CONDITIONS \*

PTIN/PTEX PTIN/PSEX WRTIN/PTIN WRTIN/PSIN PTI-PIE/PTI PTI-PSE/PTI  
 1.4344 1.4378 0.03707 0.03719 0.3029 0.3045

END OF CHOKE POINT CALCULATION

FLOW CURVE CALCULATED BY DUI

CURVE POINTS 14 AREF .100000

RES 712K) SIMULATION OF A GENERALIZED ORIFICE COMPRESSIBLE FLOW 24APR86

PR 1.00000 1.00312 1.01514 1.03504 1.05211 1.09562 1.13493 1.17963 1.22818 1.27896 1.32963 1.37810 1.41903 1.43942  
 PHI 0.0 0.06078 0.08898 0.13347 0.17425 0.21132 0.24469 0.27435 0.30030 0.32254 0.34108 0.35591 0.36783 0.37874

CURVE NUMBER 8

RES 812K) COMPLEX RESTRICTION MODEL INCLUDING GENERALIZED ORIFICE RES 2  
 BASED ON THE DODGE MODEL - L/D = .5, EDGE BREAK, OBLIQUE ANGLE

NUMBER OF ITERATIONS = 24

W= 0.19922 LBS/SEC GAMMA= 1.40 MW=28.97 LB/LB-MOL

| STN | AREA       | TT(I)  | WRT/PTA | WRT/PSA | 4FL/D | KFACT | KURVE | PT      | PS      | MN    | KFACT<br>METH | PIN<br>ROWS | LENGTH | MD     | ROUGH |
|-----|------------|--------|---------|---------|-------|-------|-------|---------|---------|-------|---------------|-------------|--------|--------|-------|
| 1   | 1000.00000 | 600.00 | 0.0000  | 0.0000  | 0.0   | 0.0   | 0     | 125.000 | 125.000 | 0.000 |               | 0           | 0.0    | 0.0    | 0.0   |
| 2   | 1.00000    | 600.00 | 0.0391  | 0.0391  | 0.0   | 0.578 | 0     | 124.909 | 124.780 | 0.043 |               | 0           | 0.0    | 0.0    | 0.0   |
| 3   | 0.60000    | 580.00 | 0.0385  | 0.0385  | 0.0   | 0.080 | 0     | 124.894 | 124.736 | 0.043 |               | 0           | 0.0    | 0.0    | 0.0   |
| 4   | 0.10000    | 540.00 | 0.0620  | 0.0620  | 0.0   | 0.050 | 0     | 124.873 | 124.677 | 0.067 | Q             | 0           | 5.5000 | 1.1280 | 50.0  |
| 5   | 0.10000    | 540.00 | 0.0518  | 1.0058  | 0.0   | 2.401 | 2     | 87.055  | 46.077  | 1.000 | Q             | 0           | 0.0    | 0.0    | 0.0   |
| 6   | 1.00000    | 520.00 | 0.0533  | 0.0533  | 0.0   | 0.0   | 0     | 87.055  | 86.851  | 0.058 |               | 0           | 0.0    | 0.0    | 0.0   |
| 7   | 1.00000    | 520.00 | 0.0522  | 0.0523  | 0.0   | 0.043 | 0     | 87.045  | 86.841  | 0.058 |               | 0           | 0.0    | 0.0    | 0.0   |
| 8   | 1000.00000 | 500.00 | 0.0001  | 0.0001  | 0.0   | 1.000 | 0     | 86.841  | 86.841  | 0.000 | PT-PS         | 0           | 3.0000 | 1.1280 | 50.0  |

\* OVERALL CONDITIONS \*

PTIN/PTEX PTIN/PSEX WRTIN/PTIN WRTIN/PSIN PTI-PIE/PTI PTI-PSE/PTI  
 1.4394 1.4394 0.03904 0.03904 0.3053 0.3053

END OF CHOKE POINT CALCULATION

FLOW CURVE CALCULATED BY DUI

CURVE POINTS 14 AREF 1.00000

RES 812K) COMPLEX RESTRICTION MODEL INCLUDING GENERALIZED ORIFICE RES 2

PR 1.00000 1.00314 1.01523 1.03525 1.05251 1.09627 1.13592 1.18113 1.23030 1.28164 1.33309 1.38218 1.42377 1.43981  
 PHI 0.0 0.00429 0.00937 0.01405 0.01835 0.02225 0.02577 0.02889 0.03162 0.03396 0.03592 0.03748 0.03865 0.03904

CURVE NUMBER 9

RES 8(A\*)COMPLEX RESTRICTION MODEL INCLUDING GENERALIZED ORIFICE RES 2  
BASED ON THE DODGE MODEL - L/D = .5, EDGE BREAK, OBLIQUE ANGLE

NUMBER OF ITERATIONS = 24

W = 0.19922 LBS/SEC GAMMA = 1.40 MW = 28.97 LB/LB-MOL

| STN | AREA       | TT(I)  | WRT/PTA | WRT/PSA | 4FL/D | KFACT | KURVE | PT      | PS      | MN    | MFACT | PT-PS | LENGTH | MD     | ROUGH |
|-----|------------|--------|---------|---------|-------|-------|-------|---------|---------|-------|-------|-------|--------|--------|-------|
| 1   | 1000.00000 | 600.00 | 0.0000  | 0.0000  | 0.0   | 0.0   | 0     | 128.000 | 125.000 | 0.000 | 0     | 0.000 | 0.0    | 0.0    | 0.0   |
| 2   | 1.00000    | 600.00 | 0.0391  | 0.0391  | 0.0   | 0.578 | 0     | 128.909 | 124.750 | 0.043 | 0     | 0.043 | 0.0    | 0.0    | 0.0   |
| 3   | 1.00000    | 580.00 | 0.0384  | 0.0305  | 0.080 | 0.050 | 0     | 128.873 | 124.736 | 0.067 | 0     | 0.067 | 0.0    | 1.1280 | 50.0  |
| 4   | 0.60000    | 540.00 | 0.0518  | 0.0620  | 0.0   | 2.401 | 2     | 87.055  | 46.477  | 0.999 | 0     | 0.999 | 0.0    | 0.0    | 0.0   |
| 5   | 0.10000    | 540.00 | 0.5218  | 1.0058  | 0.0   | 0.0   | 0     | 87.055  | 46.477  | 0.999 | 0     | 0.999 | 0.0    | 0.0    | 0.0   |
| 6   | 1.00000    | 520.00 | 0.0522  | 0.0533  | 0.043 | 0.0   | 0     | 87.046  | 46.851  | 0.058 | 0     | 0.058 | 0.0    | 0.0    | 0.0   |
| 7   | 1.00000    | 520.00 | 0.0522  | 0.0523  | 0.0   | 0.0   | 0     | 87.046  | 46.851  | 0.058 | 0     | 0.058 | 0.0    | 0.0    | 0.0   |
| 8   | 1000.00000 | 500.00 | 0.0001  | 0.0001  | 0.0   | 1.000 | 0     | 86.841  | 86.841  | 0.000 | 0     | PT-PS | 3.0000 | 1.1280 | 50.0  |

\* OVERALL CONDITIONS \*

PTIN/PTEX 1.4394 PTIN/PSEX 1.4394 WRTIN/PTIN 0.03904 WRTIN/PSIN 0.03904 PTI-PTE/PTI 0.3053 PTI-PSE/PTI 0.3053

END OF CHOKE POINT CALCULATION

FLOW CURVE CALCULATED BY DUI

CURVE POINTS 14 AREF .100000

RES 8(A\*)COMPLEX RESTRICTION MODEL INCLUDING GENERALIZED ORIFICE RES 2  
PR 1.00000 1.00314 1.01323 1.03525 1.06251 1.09627 1.13592 1.18113 1.23030 1.28164 1.33300 1.38218 1.42377 1.45941  
PHI 0.0 0.04294 0.09376 0.14054 0.18349 0.22253 0.25766 0.28889 0.31622 0.33965 0.35917 0.37478 0.38649 0.39040

RES 1 SIMULATION OF A GENERALIZED ORIFICE COMPRESSIBLE FLOW 24APR80  
 BASED ON THE DODGE MODEL + L/D = 1.2, LEADING EDGE RADIUS

FLOW PARAMETER - WGT/IN/SEC X SQRT(DES. P) / PSIA

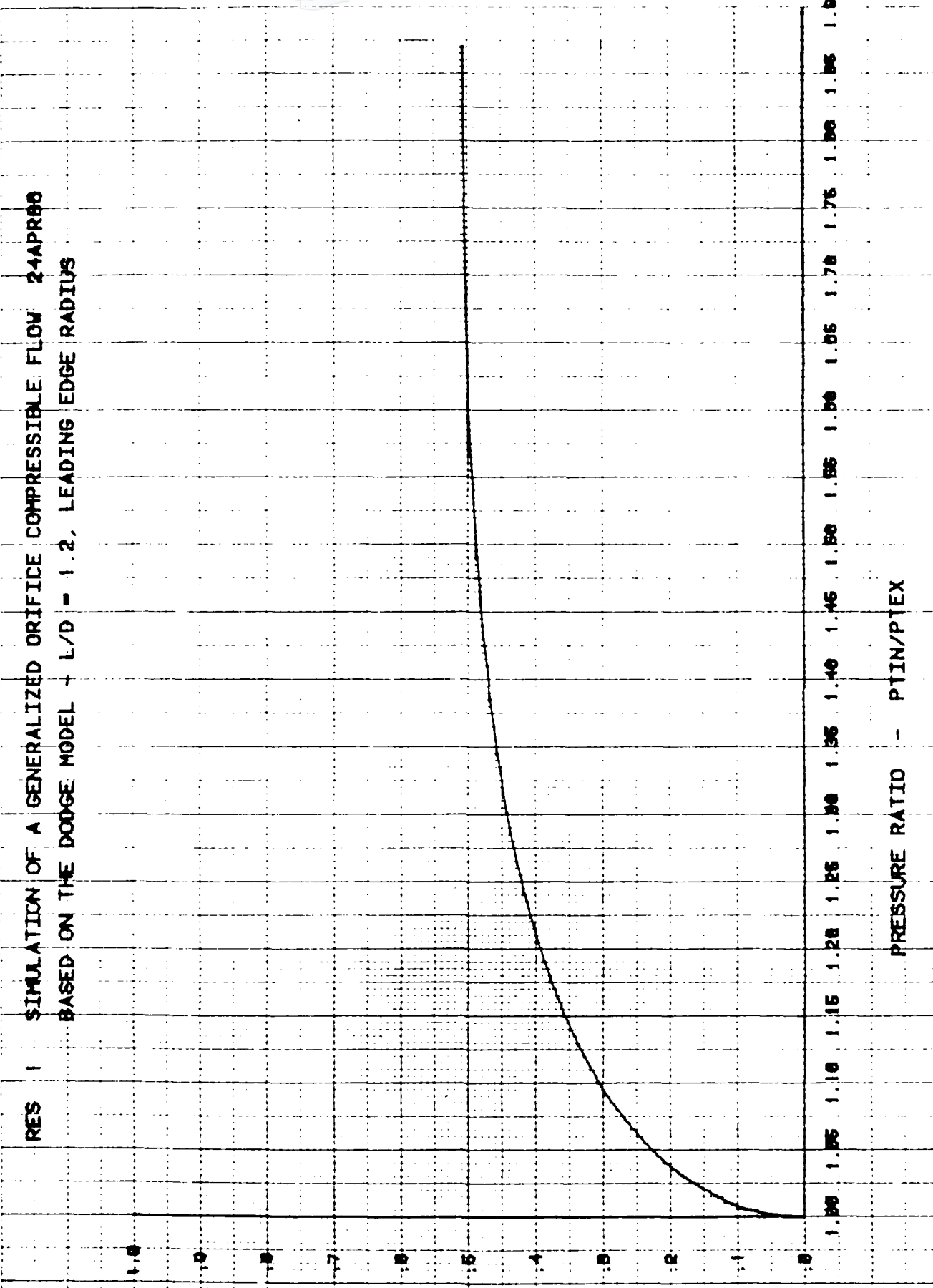

RES 2 SIMULATION OF A GENERALIZED DRIFICE COMPRESSIBLE FLOW 2-4-APR-80  
 BASED ON THE DODGE MODEL - L/D = .5, EDGE BREAK, OBLIQUE ANGLE

FLOW PARAMETER - WRT/P LB/SEC X 10<sup>3</sup> (DIN/SEC) / PSTA

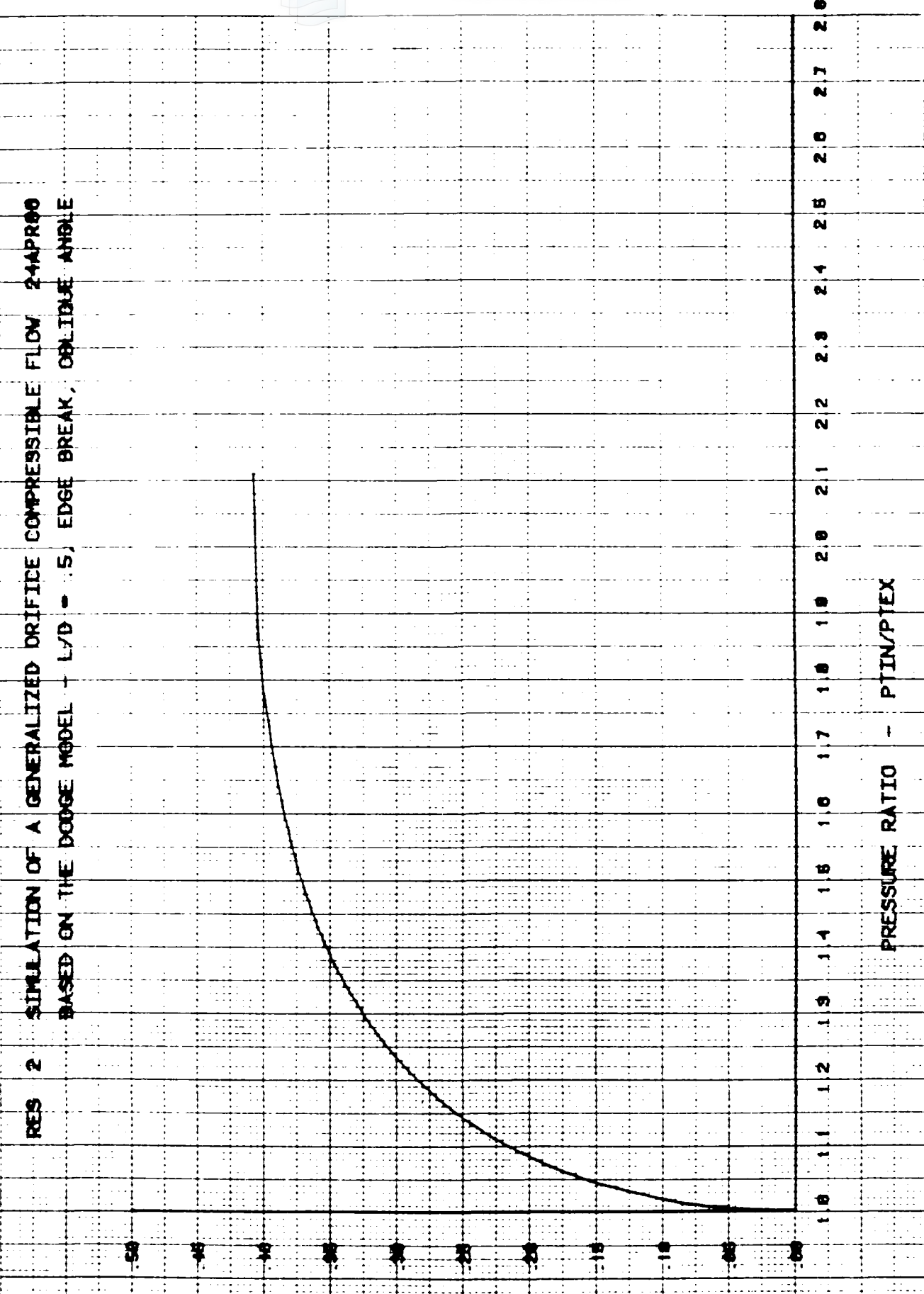

RES 3 SIMULATION OF A COMPRESSIBLE FLOW STATIC ORIFICE OFH 24APR80  
LIMIT OF THE DODGE MODEL --- TABLE VI COMPONENT LOSSES

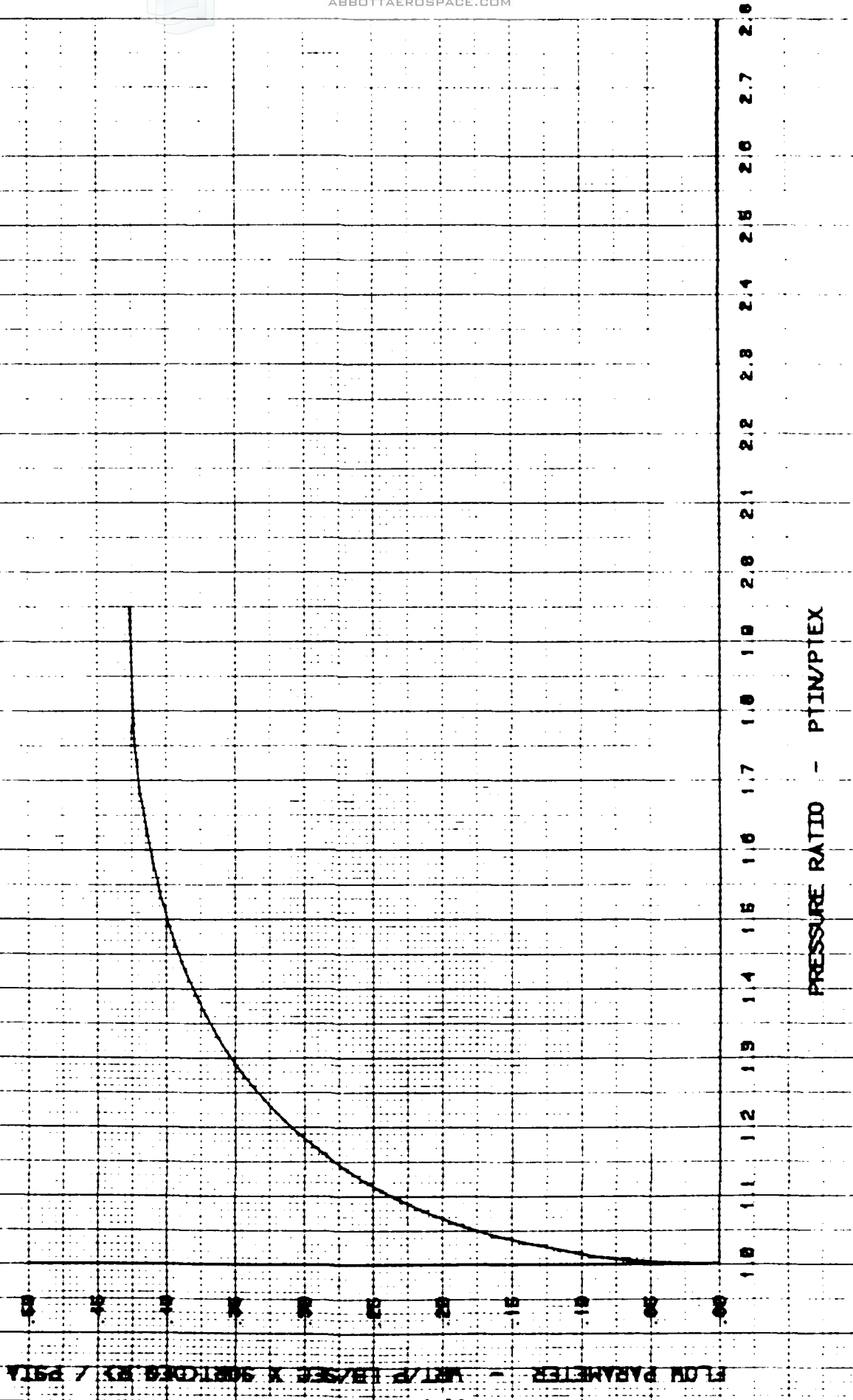

RES 4 SIMULATION OF A COMPRESSIBLE FLOW STATIC DRIFICE QFH 2-APR-68  
BASED ON PERRY EMPIRICAL DATA AND DODGE INCOMPRESSIBLE MODEL

FLOW PARAMETER - WRT/P (LBS/SEC X SQRT(DR) / PSIA

1.0 1.1 1.2 1.3 1.4 1.6 1.8 1.0 1.7 1.0 1.9 2.0 2.1 2.2 2.3 2.4 2.5 2.6 2.7 2.8

PRESSURE RATIO - P<sub>TIN</sub>/P<sub>TEX</sub>

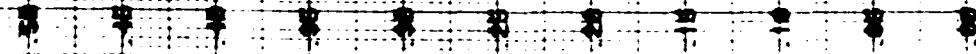

RES 5 STATIC ORIFICE RESTRICTION IN COMPRESSIBLE FLOW - GFM 2-APPROX  
 BASED ON THE K-FACTOR DATA TABLE FOR EMPIRICAL PERRY MODEL

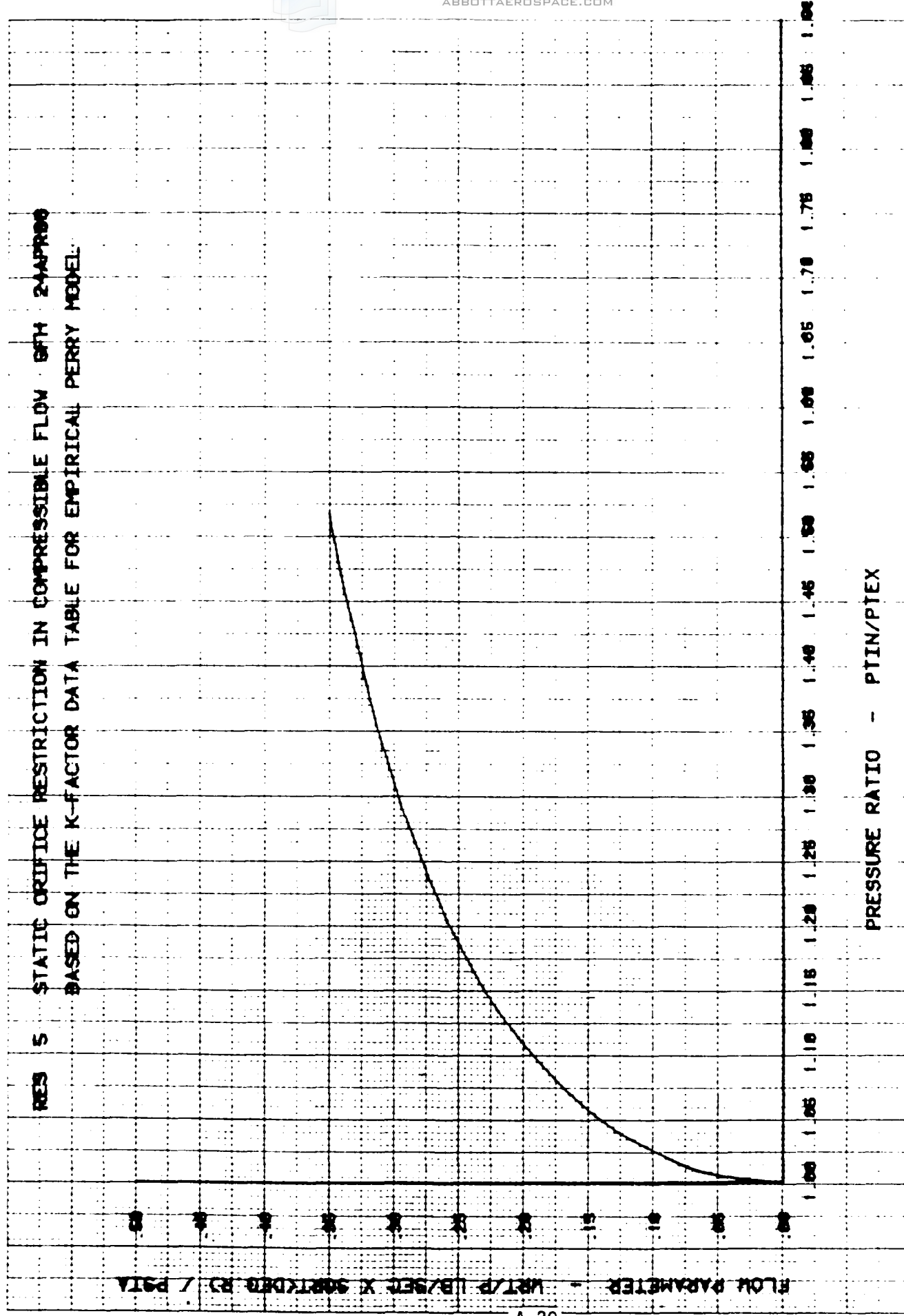

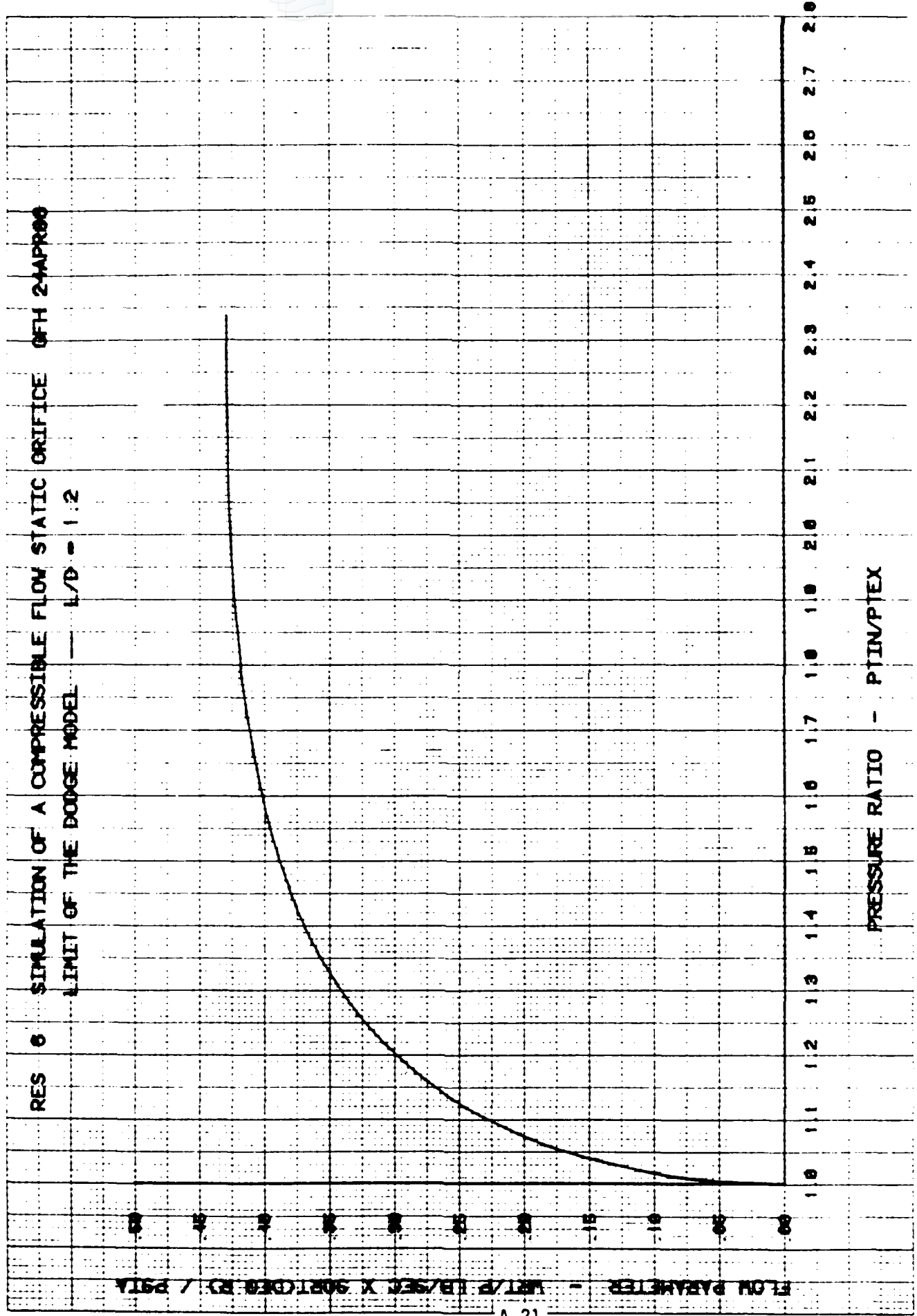

RES 7 (20) SIMULATION OF A GENERALIZED ORIFICE COMPRESSIBLE FLOW 24 APR 66  
BASED ON THE DODGE MODEL - L/D = .5, EDGE BREAK, OBLIQUE ANGLE

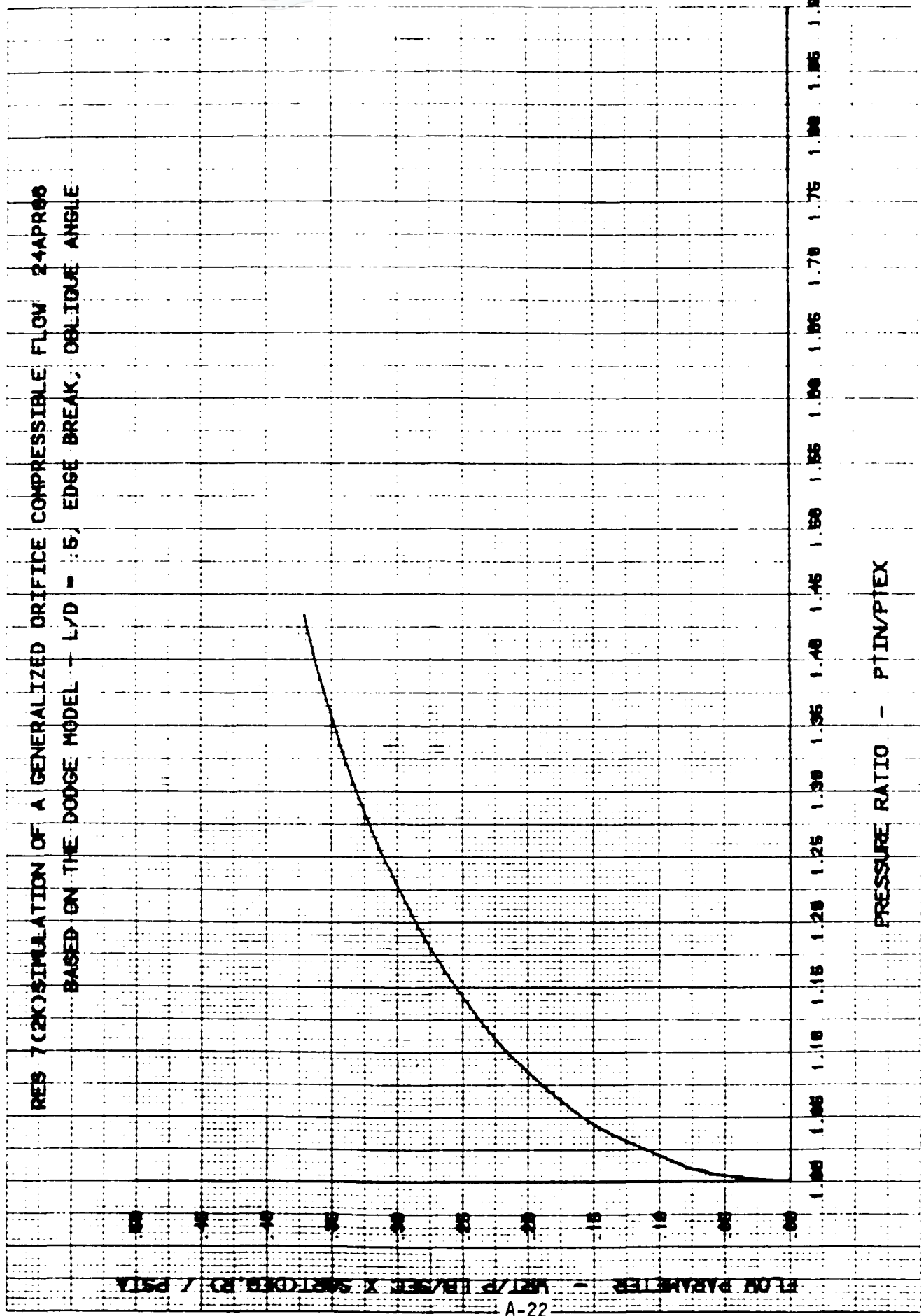

FLOW PARAMETER - W/P IN/SEC X SQR(TOT. P) / PSIA

PRESSURE RATIO - P1/P2

RES 02K>COMPLEX RESTRICTION MODEL INCLUDING GENERALIZED DRUJIDE RES 2  
BASED ON THE DODGE MODEL - L/D = .5, EDGE BREAK, COLLIBLE ANGLE

FLOW PARAMETER - WGT/LB/SEC X SQRT(DELTA P) / PATA  
X 10

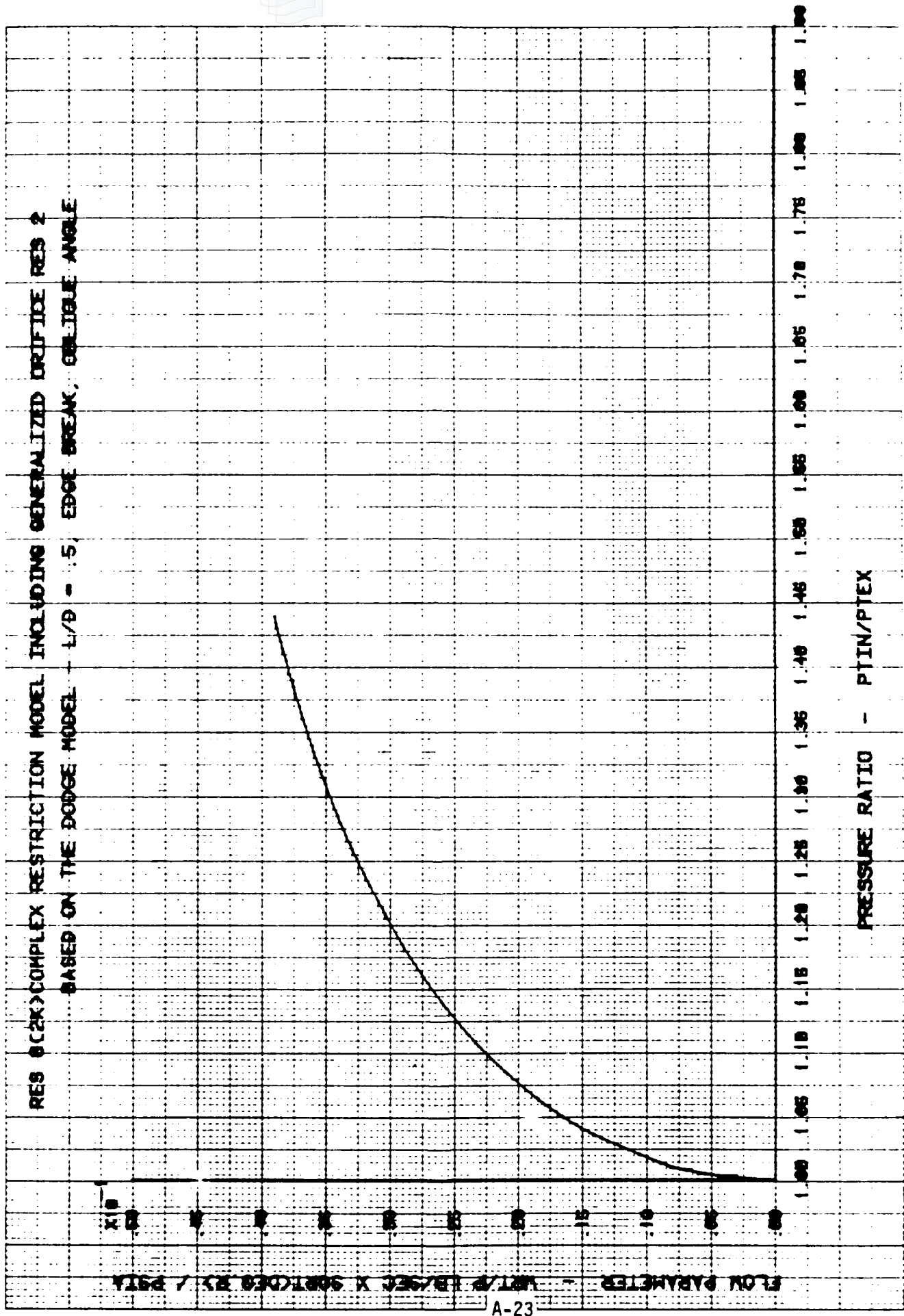

RES (A) COMPLEX RESTRICTION MODEL INCLUDING GENERALIZED ORIFICE RES 2  
 BASED ON THE DODGE MODEL + L/D = .5, EDGE BREAK, OBLIQUE ANGLE

FLOW PARAMETER - WRT/P LB/SEC X 90RT(DEG R) / PSIA

8  
 8  
 8  
 8  
 8  
 8  
 8  
 8  
 15  
 18  
 22  
 25

1.20 1.25 1.30 1.35 1.40 1.45 1.50 1.55 1.60 1.65 1.70 1.75 1.80 1.85 1.90

PRESSURE RATIO - P<sub>TIN</sub>/P<sub>TEX</sub>

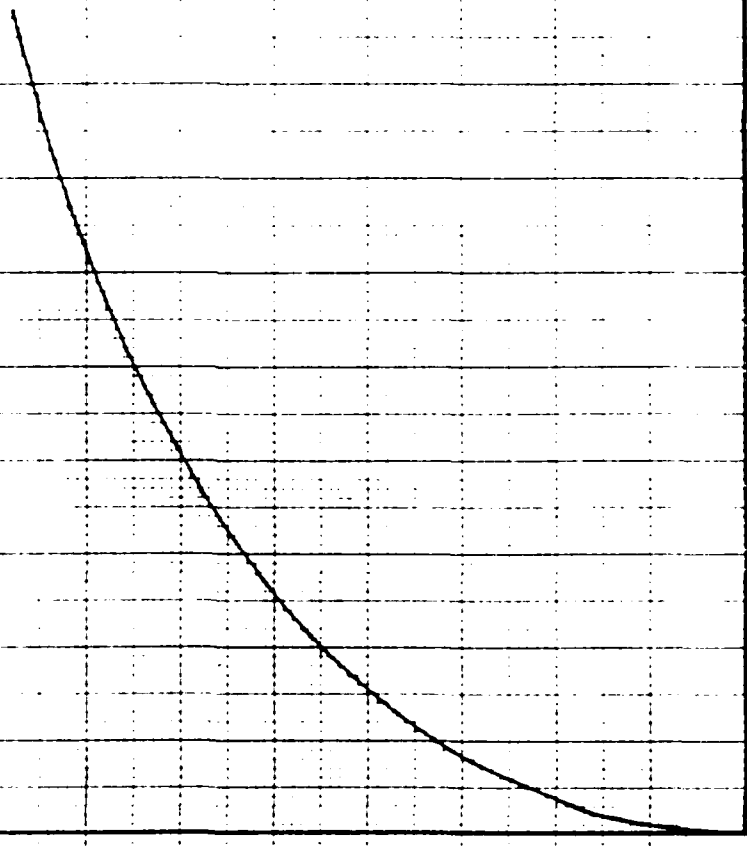

END

4-~~2~~-87

DTIC