

AD-A161 094

AFWAL-TR-85-2057

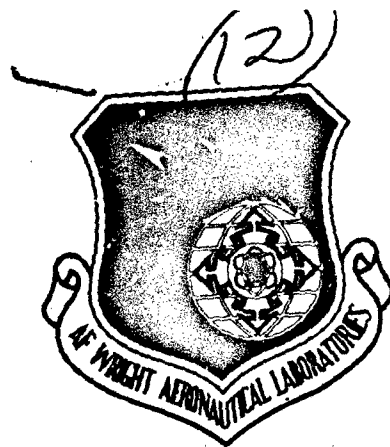

AIRCRAFT MISHAP FIRE PATTERN INVESTIGATIONS

Joseph M. Kuchta
Mining and Industrial Cadre
Green International, Inc.
Sewickley, Pennsylvania 15143

- and -

Robert G. Clodfelter
Aero Propulsion Laboratory
Wright-Patterson Air Force Base
Ohio 45433

August 1985

Final Report for Period 1 June 1984 - 31 July 1985

Approved for Public Release. Distribution Unlimited

DTIC FILE COPY

AERO PROPULSION LABORATORY
AF Wright Aeronautical Laboratories
Air Force Systems Command
Wright-Patterson AFB, Ohio 45433

Reproduced From
Best Available Copy

85 11 12 083

20000 802012

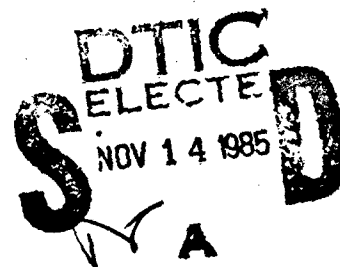

NOTICE

When Government drawings, specifications, or other data are used for any purpose other than in connection with a definitely related Government procurement operation, the United States Government thereby incurs no responsibility nor any obligation whatsoever; and the fact that the Government may have formulated, furnished, or in any way supplied the said drawings, specifications, or other data, is not to be regarded by implication or otherwise as in any manner licensing the holder or any other person or corporation, or conveying any rights or permission to manufacture, use, or sell any patented invention that may in any way be related thereto.

This report has been reviewed by the Office of Public Affairs (ASD/PA) and is releasable to the National Technical Information Service (NTIS). At NTIS, it will be available to the general public, including foreign nations.

This technical report has been reviewed and is approved for publication.



ROBERT G. CLODFELTER, Chief
Fire Protection Branch
Fuels and Lubrication Division
Aero Propulsion Laboratory
FOR THE COMMANDER



ROBERT D. SHERRILL, Chief
Fuels and Lubrication Division
Aero Propulsion Laboratory

"If your address has changed, if you wish to be removed from our mailing list, or if the addressee is no longer employed by your organization, please notify AFWAL/POSH, Wright-Patterson AFB OH 45433-6563, to help us maintain a current mailing list."

Copies of this report should not be returned unless return is required by security considerations, contractual obligations, or notice on a specific document.

Unclassified

AD-A161094

SECURITY CLASSIFICATION OF THIS PAGE

REPORT DOCUMENTATION PAGE

1a. REPORT SECURITY CLASSIFICATION Unclassified		1b. RESTRICTIVE MARKINGS	
2a. SECURITY CLASSIFICATION AUTHORITY NA		3. DISTRIBUTION/AVAILABILITY OF REPORT Approved for public release Distribution unlimited	
2b. DECLASSIFICATION/DOWNGRADING SCHEDULE NA			
4. PERFORMING ORGANIZATION REPORT NUMBER(S)		5. MONITORING ORGANIZATION REPORT NUMBER(S) AFWAL-TR-85-2057	
6a. NAME OF PERFORMING ORGANIZATION Mining and Industrial Cadre	6b. OFFICE SYMBOL (If applicable) MIC	7a. NAME OF MONITORING ORGANIZATION Computer Software Analysts, Inc. and Air Force Aero Propulsion Laboratory	
6c. ADDRESS (City, State and ZIP Code) Sewickley, PA 15143		7b. ADDRESS (City, State and ZIP Code) Dayton, Ohio 45414	
8a. NAME OF FUNDING/SPONSORING ORGANIZATION Aero Propulsion Laboratory	8b. OFFICE SYMBOL (If applicable) AFWAL/POSH	9. PROCUREMENT INSTRUMENT IDENTIFICATION NUMBER F33615-83-C-2359	
8c. ADDRESS (City, State and ZIP Code) Wright-Patterson AFB Dayton, Ohio 45433		10. SOURCE OF FUNDING NOS.	
		PROGRAM ELEMENT NO. 62203F	PROJECT NO. 3048
		TASK NO. 07	WORK UNIT NO. 87
11. TITLE (Include Security Classification) Aircraft Mishap Fire Pattern Investigations (Unclassified)			
12. PERSONAL AUTHOR(S) Joseph M. Kuchta and Robert G. Clodfelter			
13a. TYPE OF REPORT Final	13b. TIME COVERED FROM 6/1/84 TO 7/31/85	14. DATE OF REPORT (Yr., Mo., Day) August 1985	15. PAGE COUNT 186
16. SUPPLEMENTARY NOTATION Updates and expands Tech. Report AFAPL-TR-73-74			
17. COSATI CODES		18. SUBJECT TERMS (Continue on reverse if necessary and identify by block number)	
FIELD	GROUP	SUB. GR.	Aircraft Accident Investigations Fuel Properties, Fire/Explosion Patterns, Damage Analysis Jet Fuels, Hydraulic Fluids, Oil, Aircraft Combustibles
21	02		
21	04		
19. ABSTRACT (Continue on reverse if necessary and identify by block number) <p>This manual was prepared to provide the aircraft mishap investigator with "state-of-the art" data and guidelines for investigating aircraft fires and explosions. Sections are included on investigative procedures, properties of air atmospheres, properties of aircraft combustibles (liquids, gases, or solids), properties of ordnance explosives, and damage analyses relating to fires and explosions. Procedures for accumulating, developing, and analyzing the evidence are outlined, and various combustion data are summarized for use in determining the ignition source, combustible source, and mishap scenario. To help establish the mishap scenario, damage criteria are given in terms of material or biological response to fire temperatures, explosion pressures, toxic gases, and other potentially hazardous exposures. Methods for calculating combustion quantities and damage potentials, including material failures, are included in this manual.</p>			
20. DISTRIBUTION/AVAILABILITY OF ABSTRACT UNCLASSIFIED/UNLIMITED <input type="checkbox"/> SAME AS RPT. <input checked="" type="checkbox"/> DTIC USERS <input type="checkbox"/>		21. ABSTRACT SECURITY CLASSIFICATION Unclassified	
22a. NAME OF RESPONSIBLE INDIVIDUAL Robert G. Clodfelter		22b. TELEPHONE NUMBER (Include Area Code) 513/255-4208	22c. OFFICE SYMBOL AFWAL/POSH

FOREWARD

This report was prepared by the Mining and Industrial Cadre of Green International, Inc. under a subcontract with Computer Software Analysts, Inc., Dayton, Ohio, as part of a Scholarly Research Program sponsored by the Air Force Aero Propulsion Laboratory, Wright-Patterson AFB, Ohio. The contract was administered by Mr. Russell F. Mitchell and Mr. Frederick D. White of CSA and technically directed by Mr. Robert G. Clodfelter of the Air Force (AFAPL/POSH). Ms. Eva Conley was the Air Force Contract Manager and Mr. Paul Hayes, Jr. was the Air Force Task Project Engineer.

The project work by the Mining and Industrial Cadre was administered by Mr. Donald Berman. Mr. J. Kenneth Richmond served as project manager and Mr. Joseph Kuchta was the principal investigator who collaborated with Mr. Clodfelter of the Air Force to produce this report. The work was conducted during the period 1 June 1984 to 31 July 1985.

Publications of the Air Force and various research laboratories or safety organizations were relied upon for the specific information cited in this report. Special acknowledgement is given to the Pittsburgh Research Center of the U. S. Bureau of Mines which has cooperated with the Air Force over many years to produce many of the fire and explosion data relied upon in this report. The following Air Force persons contributed significantly in the review of the draft of this report: Gregory W. Gander, Air Force Inspection and Safety Center; William Q. Brookley, Aeronautical Systems Division; and Robert McGregor, Headquarters Sacramento Air Logistics Center.

The intent of this report is to provide useful technical information for the investigation of an aircraft fire or explosion mishap. It is planned to update this report in about four years. If you have any comments or information you wish to have considered during this update, please mail to: ROBERT G. CLODFELTER, AFWAL/POSH, WPAFB, OH 45433. If you discover technical errors in the current report, please contact the above at 1-513-255-4208 or AV 785-4208 immediately.

Accession For	
NTIS CRA&I	<input type="checkbox"/>
DTIC TAB	<input type="checkbox"/>
Unannounced	<input type="checkbox"/>
Justification	
By	
Distribution/	
Availability Codes	
Dist	Avail and/or Special
A-1	

QUALITY
INSPECTED
3

TABLE OF CONTENTS

	<u>Page No.</u>
I. INTRODUCTION	1
II. PROCEDURES FOR INVESTIGATING AIRCRAFT MISHAPS	3
A. Initial Actions	3
B. Investigative Procedures	4
1. Background Information	4
2. Site Inspection	5
3. Witness Accounts	10
4. Development and Analysis of Evidence	10
5. Conclusions and Report	16
III. PROPERTIES OF AIR ENVIRONMENT	17
A. Air Atmosphere Properties	17
B. Thermodynamic Gas Laws	17
IV. PROPERTIES OF AIRCRAFT COMBUSTIBLE LIQUIDS OR GASES	23
A. Densities and Specific Gravities	24
B. Flash Points and Vapor Pressures	24
C. Limits of Flammability in Air	30
D. Inerting Requirements	38
E. Ignition Energies	43
F. Ignition Quenching Distances	47
G. Ignition Temperatures	51
H. Burning Rates	62
V. PROPERTIES OF AIRCRAFT COMBUSTIBLE SOLIDS	67
A. Flammability Limits	67
B. Ignition Energies	67
C. Ignition Temperature	70
D. Burning Rates	73
VI. PROPERTIES OF HYDRAZINE	77
VII. PROPERTIES OF EXPLOSIVES	79
A. Detonation Properties	79
VIII. PROPERTIES OF FIRE EXTINGUISHANTS	81
A. Halons	81
B. Aqueous Foams	83

TABLE OF CONTENTS
(Continued)

	<u>Page No.</u>
IX. FIRE DAMAGE ANALYSIS	85
A. Fire Temperatures of Gaseous Fuels	85
B. Fire Temperatures of Solid Fuels	87
C. Heat Damage Criteria	90
1. Temperature Criteria	90
2. Radiation Criteria	95
D. Fire Damage Patterns	99
1. Ground Aircraft Fires	101
2. In-Flight Aircraft Fires	102
3. Electrical and Powered Systems	110
4. Summary of Fire Pattern Investigation Factors	114
X. EXPLOSION DAMAGE ANALYSIS	120
A. Explosion Pressures of Deflagrations	120
B. Explosion Pressures of Detonations	127
C. Explosion Pressure Damage Criteria	130
D. Blast Wave Damage Criteria	132
E. Crater and Missile Damage Criteria	145
F. Explosion-Proof and Intrinsically Safe Electrical Equipment	146
XI. TOXICITY DAMAGE ANALYSIS	152
A. Asphyxiation	152
B. Toxic Fire Gases	152
REFERENCES	155
APPENDIX	162
A. Properties of Hydrocarbons and Miscellaneous Combustibles	162
B. Conversion Factors	163
C. Glossary of Technical Terms	168

LIST OF ILLUSTRATIONS

<u>Figure</u>		<u>Page No.</u>
1	Fuel Tank Arrangement for F-14 and F-15A Aircraft	6
2	Fuel Tank Arrangement for F-111 and A-10 Aircraft	7
3	Illustrative Damage Scenario for Ground Impact Fire/ Explosion with Shallow Angle of Impact	8
4	Illustrative Damage Scenario for Ground Impact Fire/ Explosion with Steep Angle of Impact	9
5	Variation of Pressure Ratio (P_2/P_1) with Volume Ratio (V_1/V_2) in Adiabatic and Isothermal Compression of an Ideal Gas	22
6	Density Versus Temperature for Aircraft Fuels and Missile Fuels	27
7	Vapor Pressure Versus Temperature and Approximate Flash Points for Aviation Gasoline and Various Aircraft Jet Fuels	28
8	True Vapor Pressure Versus Temperature or Reciprocal Temperature for Aviation Gasoline and Various Aircraft Jet Fuels	29
9	Flash Point of Blends of Jet A or JP-8 and Jet B or JP-4 Type Fuels	31
10	Flammability and Vapor Pressure Diagram for JP-4 in Air at Various Temperatures and One Atmosphere Pressure	32
11	Flammability and Vapor Pressure Diagram for JP-5 in Air at Various Temperatures and One Atmosphere Pressure	33
12	Pressure Altitude - Temperature Limits of Flammability for Jet A and Jet B Type Fuels in Air	37
13	Effect of Tank Dynamics on the Relative Flammability Limits of JP-4, Jet B, Jet A, Jet A-1, and JP-8 Fuels	39
14	Concentration Limits of Flammability of JP-4 Vapor - Air - Inert Gas (CO_2 or N_2) Mixtures at 25°C (77°F) and One Atmosphere	40
15	Concentration Limits of Flammability of Aviation Gaso- line (115/145) Vapor - Air - Inert Gas (CO_2 or N_2) Mixtures at 25°C (77°F) and One Atmosphere	41

LIST OF ILLUSTRATIONS
 (Continued)

<u>Figure</u>		<u>Page No.</u>
16	Effectiveness of Various Inerting Agents on the Flammability of Gasoline Vapor - Air Mixtures at 25°C (77°F) and One Atmosphere	42
17	Temporal and Spatial Characterization of Various Ignition Sources	44
18	Spark Ignition Energy Versus Combustible Vapor Concentration for Various Hydrocarbons in Air at 25°C (77°F) and One Atmosphere	45
19	Minimum Ignition Energy of Propane - Oxygen - Nitrogen Mixtures as a Function of Oxygen Concentration and Mixture Pressure	48
20	Minimum Spark Ignition Energies of the Sprays of Three Jet Fuels at Various Temperatures	49
21	Correlation of Minimum Ignition Energy and Quenching Distance for Various Combustibles in Oxidant Atmospheres of 21 to 100% Oxygen and Pressures of 0.1 to 2 Atmospheres	50
22	Variation of Ignition Delay with Reciprocal Temperature in Autoignition of Four Aircraft Fuels in Stagnant Air at 1/2 and One Atmosphere.	53
23	Effect of Oxygen Partial Pressure on Minimum Autoignition Temperature of JP-6 Fuel Vapor - Oxygen - Nitrogen Mixtures at Various Total Pressures	54
24	Minimum Autoignition Temperatures of Phosphate Ester, Mineral Oil, and Water-Glycol Lubricants in Air at Various Initial Pressures	56
25	Minimum Autoignition Temperatures of Houghto-Safe-1055, Mobil DTE-103, and MIL-L-7808 Lubricants in Air at Various Initial Pressures.	57
26	Hot Surface Ignition Temperatures as a Function of the Surface Area of the Heat Source for Various Hydrocarbon Fuels and an Engine Oil in Near Stagnant Air.	60
27	Flame Speed (S_f), Gas Velocity (S_g), and Burning Velocity (S_u) for Different Equivalence Ratios of Methane - Air Explosions at Atmospheric Pressure and 298°K (77°F)	63
28	Rate of Flame Spread Versus Liquid Fuel Temperature for Jet A and Jet B Type Fuels in Air at Atmospheric Pressure	64

LIST OF ILLUSTRATIONS
(Continued)

<u>Figure</u>		<u>Page No.</u>
29	Linear Burning Rate (Regression Rate) of Combustible Liquids as a Function of Pool Diameter	65
30	Effect of Oxygen Partial Pressure on the Flame Spread Rates of Materials in Oxygen-Nitrogen Mixtures at 1 to 6 Atmospheres Total Pressure (Upward Burning at 45° Angle)	74
31	Fire Control and Extinguishing Times as a Function of AFFF Solution Application Rate for Jet A Fuel Fires Using Air Force and Navy Fire-Fighting Vehicles	84
32	Predicted Temperature History of a Titanium Fuselage Adjacent to a Severe External JP-4 Jet Fuel Fire	93
33	Thermal Irradiance of Gasoline Tank Fires as a Function of a Dimensionless Distance Ratio (Irradiance Distance/Tank Fire Radius)	96
34	Heat Release and Oxygen Index of Composite Constituents for Use in Aircraft Interior Panels	98
35	Variation of Peak Fireball Width with Impact Velocity for Vertical Drops with Five-Gallon Metal Containers	100
36	Aircraft Fire Pattern for an External In-Flight Fire	103
37	"Broomstraw" Evidence on Damaged Aluminum Metal Strip	104
38	Soot/Fire Pattern Relative to Air Flow	105
39	Analysis of Evidence on Soot or Discoloration Patterns of Aircraft Materials in In-Flight Fires	106
40	Analysis of Mechanical Damage of Soot Pattern	107
41	Analysis of Evidence on Soot or Combustion Patterns of Fractured Aircraft Materials	108
42	Analysis of Evidence on Soot or Combustion Patterns in Folds of Fractured Aircraft Materials	109
43	Analysis of Fire Damage to Open and Closed Containers	111
44	Power Feed Cable Cut by Propeller Blade when Electric Power was Present. Note Smoothly Rounded Strands Resulting from Melting.	112
45	Warning Light Bulb with Envelope Intact Showing Stretching of Filament. Indicates Bulb was Illuminated at the Time of Receiving Physical Shock during Accident.	113

LIST OF ILLUSTRATIONS
(Continued)

<u>Figure</u>		<u>Page No.</u>
46	Analysis of Mechanical Damage to Rotating and Nonrotating Parts	115
47	Damage to Jet Engine Compressors after Impact under Power and Nonpower Conditions	116
48	Effect of Fuel Concentration on Explosion Pressure for Methane-Air Mixtures at 25°C (77°F) and 1 atm (244 in. ³ vessel).	121
49	Explosion Pressure Histories for Stoichiometric Methane-Air Mixtures with Added Nitrogen at 25°C (77°F) and 1 atm (920 ft. ³ vessel).	122
50	Explosion Pressure Histories for Stoichiometric Methane-Air Mixtures with Added Halon 1301 (CF ₃ Br) at 25°C (77°F) and 1 atm (920 ft. ³ vessel).	123
51	Typical Pressure - Time Profiles from Incendiary Firings (60° Upward Pitch) into a 92-Gallon Tank (12.3 ft. ³) Containing JP-4 and JP-8 Jet Fuels at 1 and 2 Atmospheres Initial Pressure (50 caliber API, Type M-8, Ammunition).	124
52	Effectiveness of Polyurethane Foam in Quenching Ignitions of Near-Stoichiometric n-Pentane-Air Mixtures (75°F) in a Cylindrical Vessel (6 in. diam. x 60 in. length); Arrestor Length/Ignition Void Length = 30 in./18 in. (1.67).	126
53	Effect of Vent Ratio on Explosion Pressure for 5% Propane-Air Mixtures (75°F) in a 3 ft. ³ Tank at Atmospheric Pressure.	128
54	Calculated Pressure Rise vs. Vent Ratio ($A/v^{2/3}$) for Stoichiometric Methane-Air Ignitions with Added Nitrogen at 25°C (77°F) and 1 atm.	129
55	Highly Ductile Tension Failure	133
56	Medium Ductile Tension Failure	134
57	Brittle Tension Failure	135
58	Shear Failure	136
59	Local Crippling in Compression Failure	137
60	Compression Failure with Diamond Shape Buckle	138
61	Fatigue Failure	139

LIST OF ILLUSTRATIONS
(Continued)

<u>Figure</u>		<u>Page No.</u>
62	Peak Overpressure vs. Scaled Distance for Hemispherical TNT Surface Bursts	142
63	Peak Overpressure vs. Scaled Distance with Approximate Biological and Material Effects	143
64	Depth of Penetration of Mild Steel vs. Striking Velocity for Steel Fragments of Various Weights (m)	144
65	Velocity-Time Profile and Potential Biological Damage Levels for Translation of 1/8 in. (0.32 cm) Diameter Nylon Sphere	147
66	Minimum Ignition Current versus Voltage for Resistance Circuits (Inductance = 1 mH) in Class I Hazardous Locations: Circuits Containing Cadmium, Zinc, or Magnesium	150
67	Minimum Ignition Current versus Voltage for Resistance Circuits (Inductance = 1 mH) in Class I Hazardous Locations: Circuits Not Containing Cadmium, Zinc, or Magnesium	151

LIST OF TABLES

<u>Table</u>		<u>Page No.</u>
1	Composition and Properties of Dry Air	18
2	Standard Air Atmosphere	18
3	Physical Properties of Gases	20
4	Typical Volatility Properties of Aircraft Fuels and Missile Fuels	23
5	Summary of Combustion Properties of Jet Fuels and Gasolines	25
6	Summary of Combustion Properties of Hydraulic Fluids and Lubricating Oils	26
7	Effect of Reduced Pressure on Flammability Limits and Minimum Oxygen Requirements for Gasolines and Jet Fuels in Air and Air-Inert Mixtures	36
8	Effects of Pressure and Oxygen Concentration on the Minimum AIT's of Aircraft Fuels, Hydraulic Fluids, and Lubricants	55
9	Shock Wave and Adiabatic Compression Temperatures of Air	58
10	Comparison of Heated Vessel AIT's and Hot Manifold Ignition Temperatures of Aircraft Fuels and Fluids in Air at One Atmosphere	59
11	Minimum Hot Gas Ignition Temperatures of Hydrocarbon Fuels and Engine Oil (vapor-air mixtures) with Various Hot Air Jets	61
12	Properties of Combustible Metals and Nonmetals	68
13	Spark Ignition of Combustible Solids in Air and Oxygen at Atmospheric Pressure	69
14	Radiant Ignition Energies of Combustible Solids in Air at Atmospheric Pressure	69
15	Ignition Temperatures of Combustible Solids in Air	71
16	Ignition Temperatures of Plastic and Rubber Dusts in Air	72
17	Heated Vessel and Hot Plate Ignition Temperatures of Fabric or Sheet Combustibles in Air and Oxygen at Atmospheric Pressure	72

LIST OF TABLES
 (Continued)

<u>Table</u>		<u>Page No.</u>
18	Burning Rates and Flame Spread Rates by Various Methods for Cotton Sheeting in Air at Atmospheric Pressure	73
19	Flame Spread Rates (45° Angle Upward) of Flammable Fabrics or Sheet Combustibles in Air and Oxygen Atmospheres	75
20	Flame Spread Rates (Downward Burning) of Sheet-Type Combustibles in Air and Oxygen Atmospheres	76
21	Properties of Hydrazine	77
22	Pressure and Surface Effects on Autoignition of Hydrazine Vapor Mixed with Air	78
23	Properties of Explosives	80
24	Physical Properties of Halogenated Hydrocarbon Fire Extinguishants	82
25	Aircraft Fixed Fire Extinguishing Systems	81
26	Thermochemical Properties of Plastics or Polymer Materials	88
27	Adiabatic Combustion (Flame) Temperatures of Metals and Nonmetals in Oxygen at 1 Atmosphere Pressure	89
28	Typical Burning Temperatures for Cigarettes, Matches, and Lighters	89
29	Temperature Limits of Various Textiles	90
30	Temperature Limits of Plastic, Rubber, and Other Materials	91
31	Melting Points of Metal and Nonmetal Substances	92
32	Color Temperatures of Iron or Steel	92
33	Failure Times for Components Exposed to a 2000°F Fire	95
34	Threshold (Minimum) Radiation Intensities for Various Thermal Effects	95
35	Summary of Computed Values Bearing on Radiative Hazards of Fires	99
36	Mechanical Properties of Metals and Alloys	131
37	Peak Overpressures for Failure of Structural Materials	141

LIST OF TABLES
(Continued)

<u>Table</u>		<u>Page No.</u>
38	Scaled Distance for Building Damage from Statistical Survey of Chemical Explosions	141
39	Threshold Overpressures for Biological Damage by Pressure Pulses of Short Duration (3-5 ms)	145
40	Effects of Reduced Oxygen Concentration in Human Respiration at Sea Level	152
41	Tolerance of Selected Combustion Products	153
42	Toxicology of Some Highly Toxic Fire Gases	153

I. INTRODUCTION

The proper investigation of aircraft mishaps is essential for determining their cause and scenario and for preventing their recurrence. This requires a methodical and thorough investigation of the available evidence, knowledge of pertinent properties of the aircraft combustibles and noncombustibles, and application of various physical and chemical principles to develop the mishap scenario. Under previous research sponsored by the Air Force (Ref. 1), a useful fire and explosion manual for accident investigators was prepared through the cooperation of the Federal Bureau of Mines (Pittsburgh Research Center). The present manual updates and expands the data base on the properties of aircraft combustibles, includes more specific guidelines for analyzing aircraft fires or explosions, and provides a wider scope of information for investigating different mishap scenarios.

Initially, the manual outlines general procedures for conducting an aircraft mishap investigation. This section summarizes initial actions of the investigating team and the procedures for accumulating, developing, and analyzing the evidence. Important factors in establishing the most plausible mishap scenario are delineated.

Subsequent sections are devoted to the physical and thermodynamic properties of the air environment in which aircraft mishaps may occur, combustion properties of aircraft combustible liquids or gases (fuels, oils, lubricants, hydraulic fluids, etc.), combustion properties of aircraft combustible solids (metals, fabrics, plastics, etc.), and detonation properties of explosives that may be found in the weapons of combat aircraft. Particular attention is given to the volatility limits (flash points), flammability limits, ignition temperatures, ignition energies, quenching distances, and burning rates of the flammable materials (liquids, gases, or solids) in air and other oxidant atmospheres. Empirical rules are presented for extrapolating the data to various static or dynamic conditions. Where the specific information is not available for aircraft combustibles, the data trends are illustrated by those available for neat organic or inorganic compounds. The necessary theory and definitions for understanding the combustion data are included under the applicable section.

Final sections of the text provide guidelines and pertinent data for analyzing fire, explosion, and toxicity damage in an aircraft mishap. Damage criteria are given in terms of material or biological response to fire temperatures, thermal radiation, combustion explosion pressures, blast or shock wave overpressures, missiles or flying fragments, and toxic or obnoxious product concentrations. Useful guidelines for interpreting the damage from fire or explosion patterns are included for both inflight and ground type accidents. Also included are the effects of inerting, quenching (flame arresting), and venting on the explosion pressure potential of hydrocarbon fuel-oxidant systems. In addition, methods are outlined for calculating flame temperatures, explosion pressures, and energy equivalences of various reacting systems.

Although this manual contains many useful data and guidelines for investigating aircraft mishaps, the Air Force investigator must necessarily comply with the military guidelines and regulations, such as those specified in the

AFR 127-4 Manual (Ref. 2). Accident manuals by the Federal Aviation Administration (FAA) (Ref. 3), National Fire Protection Association (NFPA) (Ref. 4), and International Civil Aviation Organization (ICAO) (Ref. 5) can also be helpful. Publications cited in the present report are identified in the reference section, which also includes separate listings of Air Force documents on aircraft systems and accident or safety related items.

The appendix gives selected properties of families of organic or inorganic compounds for use in estimating the combustion hazards of aircraft combustibles containing such compounds. In addition, the Appendix gives a list of conversion factors for various physical quantities and a glossary of many fire/explosion terms.

II. PROCEDURES FOR INVESTIGATING AIRCRAFT MISHAPS

A. INITIAL ACTIONS

The actions taken prior to the formal investigation of an aircraft mishap can have a great bearing on the outcome of the investigation. These actions will include measures to protect the available evidence for the investigating team and to avoid any life or property loss. The team of investigators should include experts in combustion, aerodynamics, and other disciplines of interest. They should meet as soon as possible to obtain a briefing of the accident, decide upon the plan(s) of action, and establish task groups to accomplish certain well-defined objectives. The head of the investigating team must organize and coordinate the various actions to insure that all aspects of the accident are properly covered. Particularly important initial actions are as follows:

- (1) Isolation of mishap site
- (2) Protection of evidence
- (3) Recovery of material evidence
- (4) Photographic documentation of material evidence
- (5) Documentation of witness accounts

Isolation of the mishap site helps to insure recovery and protection of the available evidence and also minimizes human exposures to any life hazards that may still exist; flammable or toxic gases can be present even after an extinguished fire. Since aircraft explosions may result in flying fragments, areas beyond the mishap site should be searched to recover missing items. Before removal of any fire or explosion debris, the accident area should be photographed from different angles and close-up exposures (preferably color) obtained of all damaged or suspected items; these items also need to be tagged.

Accounts of the mishap should be obtained as soon as possible from surviving flight personnel, remote observers, and such possible witnesses as medical, security, or fire-fighting crews who arrive later on the scene. Of particular interest is what the witness saw, heard, and experienced before and after the accident, together with his/her proximity and activity during the course of events. During an investigation, various expert witnesses may be required to help substantiate any evidence.

The Air Force divides mishaps into three classes: Class A flight mishaps include those with damage that exceeds \$500,000, a destroyed aircraft regardless of cost, or a loss of life, regardless of the cost of damage to the aircraft; Class B mishaps are those with \$100,000 to \$500,000 damage; Class C mishaps are those that involve damage costing between \$1,000 and \$100,000 to repair. Once a Class A mishap occurs, a board of qualified officers is convened, headed by a president who must be a Colonel or higher. He or she will be assisted by three functional experts from the medical, operational, and maintenance fields, and by another board member who, as a trained flight safety officer, coordinates the investigative efforts. During the investigation, which must be completed within 30 days, these experts will focus on all aspects of the mishap in question - pilot, mission, machine, and environment.

B. INVESTIGATIVE PROCEDURES

The basic elements of fact finding and problem solving are involved in any mishap investigation. In aircraft situations, the investigator's task is difficult because of the complexity of many aircraft systems and because of the widely different operational conditions under which fire or explosion mishaps may occur. Frequently, crucial evidence is destroyed by fire; also, the available evidence may be incomplete, inconsistent, or only circumstantial. Accordingly, a methodical plan is essential for accumulating and developing the evidence needed to fully explain the accident. Such investigative guidelines for fire or explosion-type accidents are summarized herein:

- (1) Accumulation of background information
- (2) Inspection of mishap site
- (3) Review of witness accounts
- (4) Development and analysis of evidence
 - . Source of combustible
 - . Source of ignition
 - . Fire scenario
 - . Damage patterns
 - . Material analyses
- (5) Conclusions and report

1. Background Information

Most of the background information pertaining to the mishap and aircraft is obtained from the briefings and documentation provided by the investigative board or Air Force officials. The investigator should prepare a checklist of the items on which evidence or information is to be accumulated throughout the investigation. As a minimum, the checklist should include the following:

- (1) Aircraft: Description, damage, and performance history.
- (2) Aircraft Subsystems: Description, location, function, damage, and performance history.
- (3) Mishap Type: Ground or in-flight fires, explosions, collisions, or combinations thereof.
- (4) Flight Conditions: Velocity, altitude, and weather conditions; flight profile before and during mishap.
- (5) Fuels or Fluids: Type, quantity, location, and potential leakage or spillage.
- (6) Flammable Solids: Type, location, and distribution.
- (7) Sequence of Events: Temporal and spatial description of events before, during, and after the mishap.
- (8) Ignition Source: Electrical, mechanical, chemical, or open flame source.

- (9) Fire Evidence: Ignition and combustible source; material damage due to high temperatures.
- (10) Explosion Evidence: Ignition and combustible vapor source, ordinance source, or high impact condition; material damage due to high pressure or high velocity forces.
- (11) Other Mishap Evidence: Human errors, medical records, pilot logs, radio transmissions, radar transmissions, and any security violations.

A close examination should be made of aircraft maintenance records, flight logs, weather reports, radio or radar transmissions, previous accident histories, and other records that may be helpful in developing the evidence. Recent changes in equipment, procedures, or operating conditions can be especially significant. The investigator should take advantage of the technical libraries at Air Force installations to obtain reference information on any aircraft system. In all such investigations, a pictorial diagram of the aircraft and its subsystems is useful in understanding the possible conditions that could result in the particular accident. Figures 1 and 2 show such diagrams for the fuel tank arrangements of four typical service aircraft, the U. S. Navy F-14 and U. S. Air Force F-15A, F-111, and A-10.

At this time, the investigator must be open-minded and reserve any judgment until all material and human factors have been fully considered.

2. Site Inspection

Inspection of the mishap site is essential to the accumulation of physical evidence in the investigation. Since the aircraft wreckage may be widely dispersed, as in a crash or explosion situation, a grid map should be prepared to identify the relative location of aircraft components and damage to surroundings.

Initially, the gross wreckage and surroundings are examined to characterize the type of mishap, if not already known, and the pattern of external damage. Evidence of interest includes crater formation and aircraft fragmentation in ground impact cases; fuel tank or engine bay fragmentation in explosion cases; aircraft destruction in fire cases without explosions; and spatial distribution of the wreckage debris in all cases, including mid-air type collisions. The nature of such evidence can also be useful in determining the probable velocity, attitude, and direction or flight path of the aircraft in a crash-type accident. The angle of impact is most crucial in the damage sustained by aircraft in a crash-type situation. Some of these points are illustrated in Figures 3 and 4 for ground impact fires or explosions.

Subsequently, a detailed examination is made of the wreckage components to obtain evidence on the origin of any fire or explosion, patterns of propagation and localized damage, and possible material failures or system malfunctions. The investigator should note: (1) damage to fuel tanks and fuel, oil, and hydraulic fluid lines with particular attention to ruptures, loose fittings, and distorted or severed lines; (2) damage to electrical systems with special attention to fused, beaded, or severed wire strands and destroyed wire insulation; (3) damage to powered systems as evidenced by seized bearings, broken or

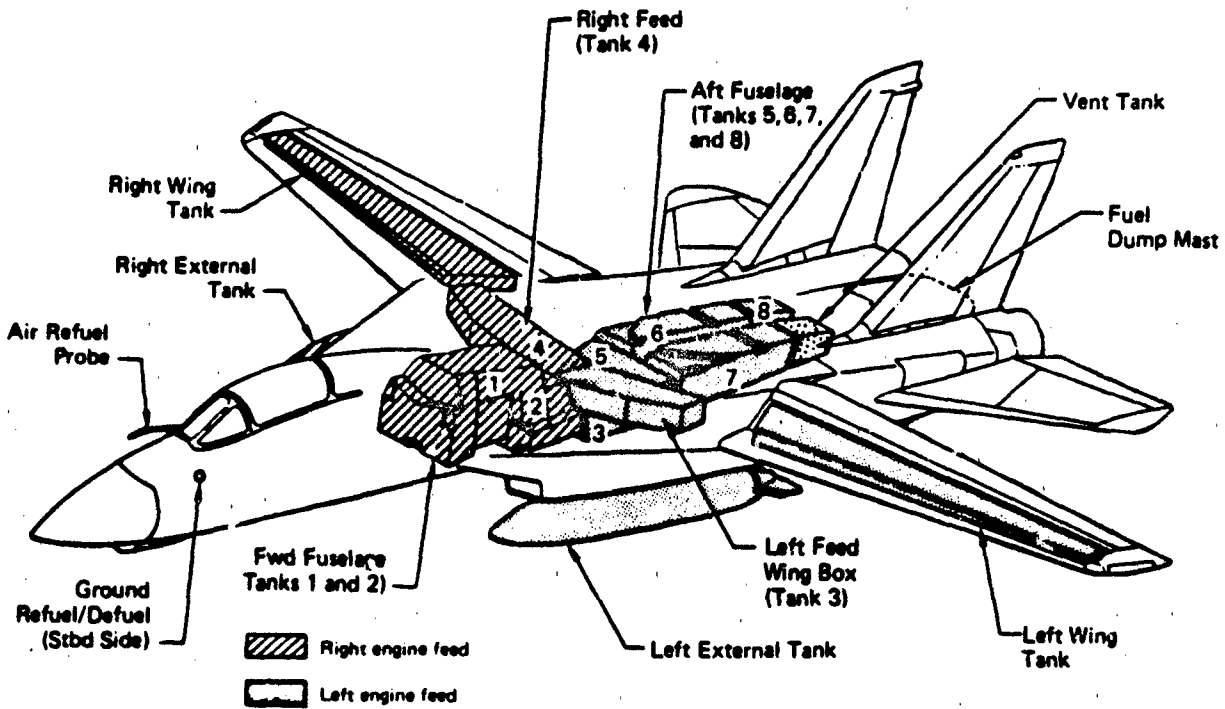

F-14 FUEL TANK ARRANGEMENT

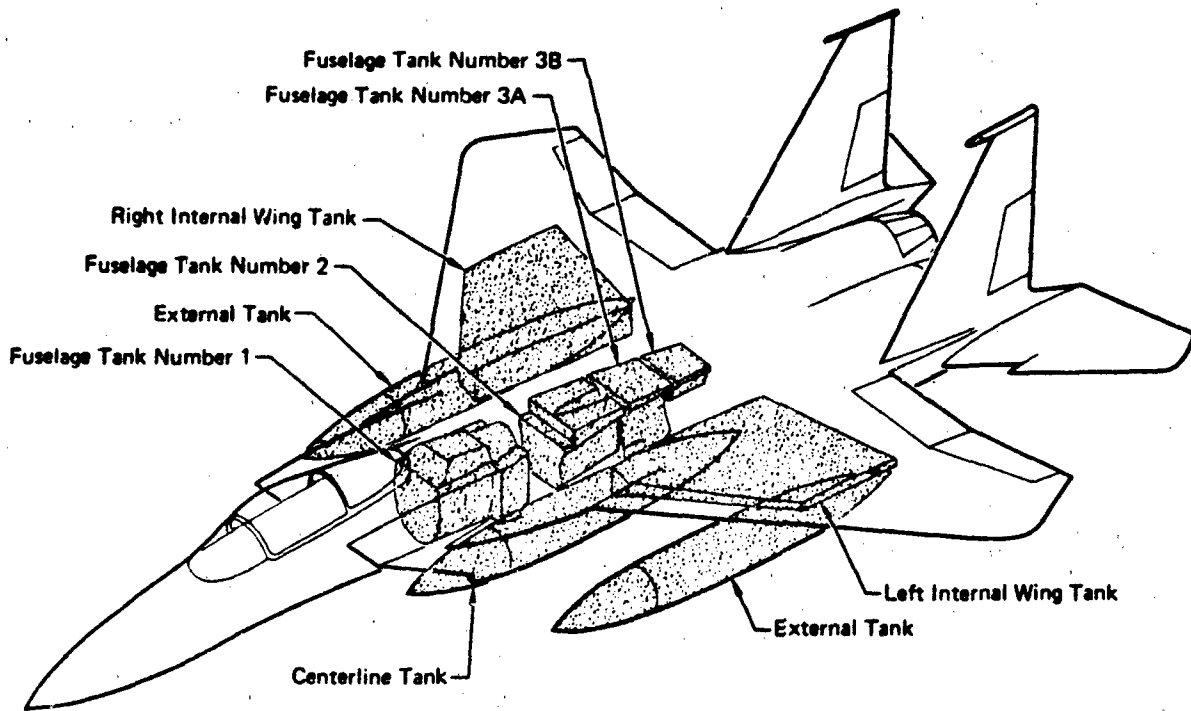

F-15A FUEL TANK ARRANGEMENT

Figure 1. Fuel Tank Arrangement for F-14 and F-15A Aircraft

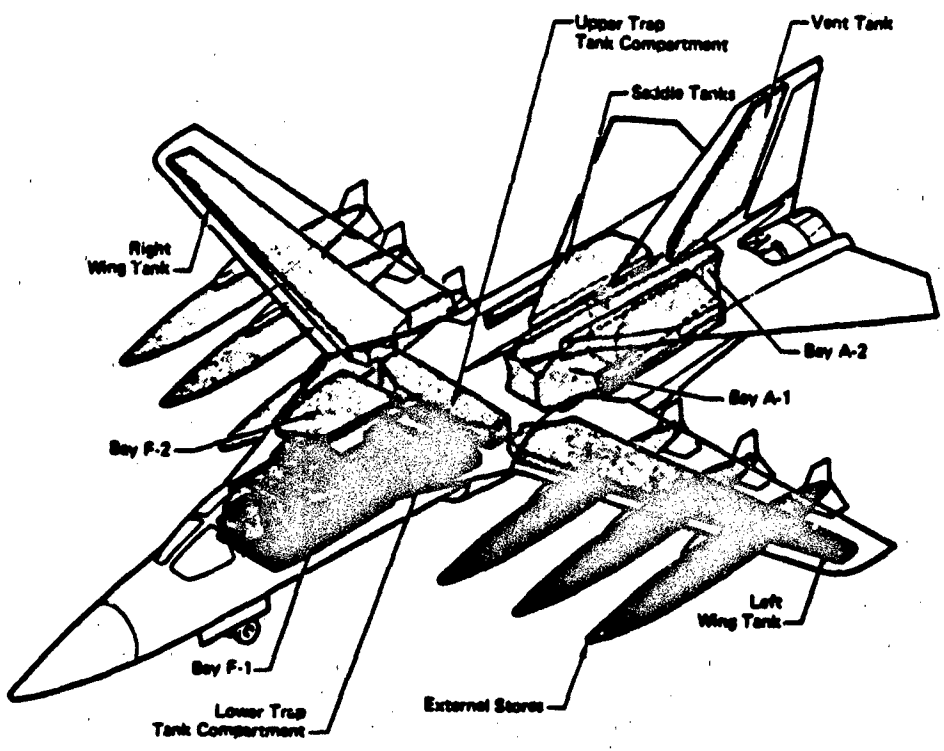

F-111 FUEL TANK ARRANGEMENT

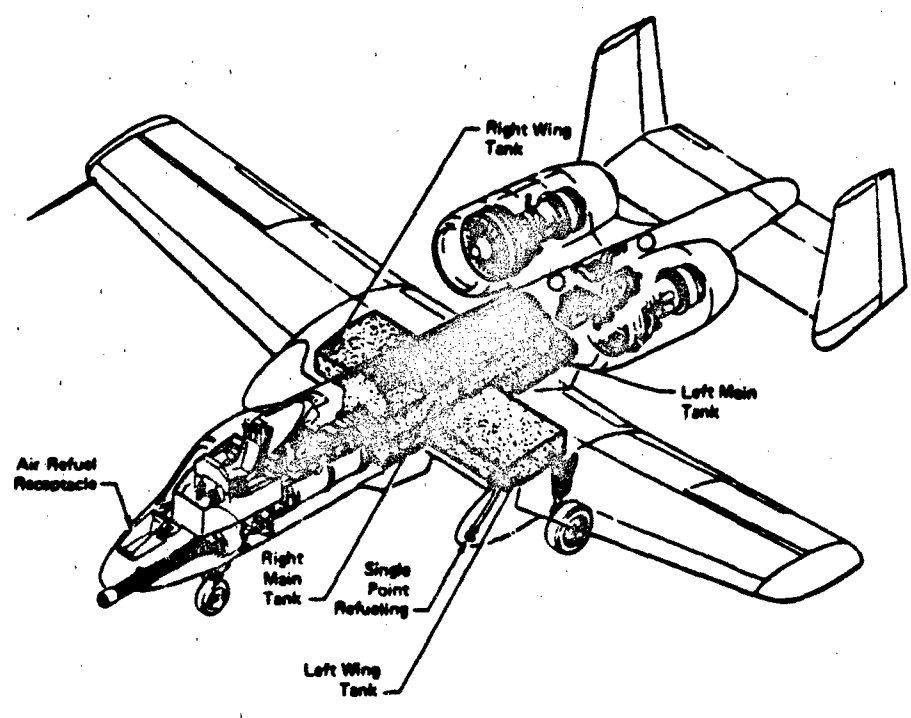

A-10 FUEL TANK ARRANGEMENT

Figure 2. Fuel Tank Arrangement for F-111 and A-10 Aircraft

GROUND IMPACT FIRE/EXPLOSION SHALLOW ANGLE OF IMPACT

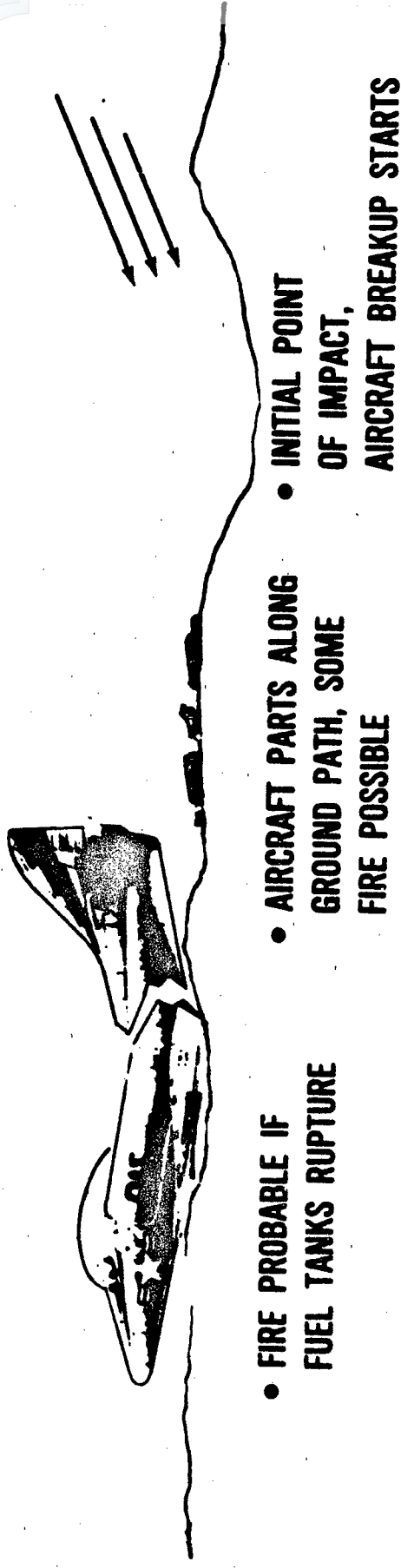
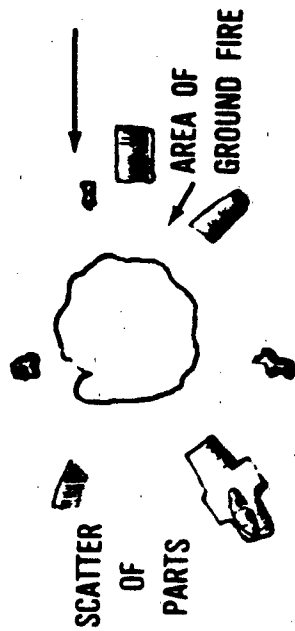

Figure 3. Illustrative Damage Scenario for Ground Impact Fire/Explosion with Shallow Angle of Impact

GROUND IMPACT FIRE/EXPLOSION STEEP ANGLE OF IMPACT



- PROBABLE FIRE BALL OF INTENSE BURNING, BUT OF SHORT DURATION
- RESIDUAL FIRE IN AND AROUND CRATER
- LOCATION OF PARTS IMPORTANT; HOWEVER, COULD HAVE BEEN MOVED
- WAS THERE A FIRE PRIOR TO IMPACT???

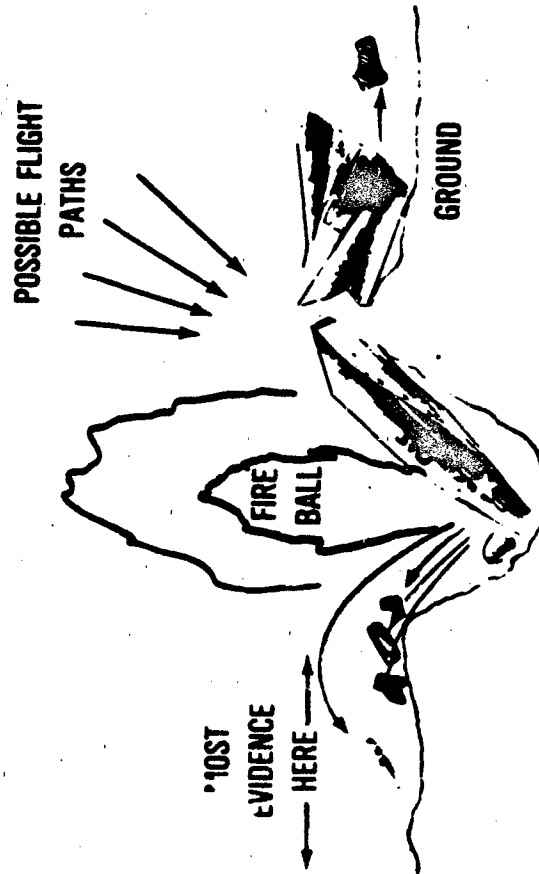

Figure 4. Illustrative Damage Scenario for Ground Impact Fire/Explosion with Steep Angle of Impact

bent rotating blades, and seal failures; (4) rupture of oxygen supply bottles which would intensify any combustion; (5) severance of flight control cables; and (6) other fire/explosion-related damage such as soot formation, metal discoloration or melting, material consumption, material fragmentation, and failure of metal fasteners.

In documenting the fire damage, it is also important to note the pattern of soot formation and burning on exposed and shielded surfaces and edges of fractured materials for use in ascertaining when, where, and how fire occurred; similarly, the nature of a material fracture is essential to any explosion or material failure analysis. Damage patterns are further discussed under the development and analysis of evidence.

Reference to Air Force technical orders should be made in searching for mishap evidence that is specific to flight controls, aircraft performance, and normal or abnormal functioning of an aircraft subsystem.

3. Witness Accounts

After the mishap site inspection, the investigator should review the witness accounts for consistency with the known physical evidence. The witnesses, including surviving flight crew members, are interrogated when necessary to help clarify any inconsistent witness account or confirm newly developed evidence. It is important to recognize that witness accounts are subjective and subject to the sight and hearing limitations of the individual in resolving a rapid sequence of events. For example, it is not unusual for a witness to claim hearing two explosions when in fact only one occurred; or to exaggerate the size and velocity of rapidly moving objects; or to give poor distance estimates. Color distinctions can be equally troublesome for observers. Therefore, witnesses should be requested to qualify their observations relative to known landmarks, events, and other helpful guides for establishing their evidence spatially and temporally. At this time, the investigator should decide what facts are known and what specific evidence needs to be further substantiated or developed.

4. Development and Analysis of Evidence

After accumulation of the available evidence, analyses are made to develop a plausible scenario, including the probable cause of the mishap. In fire or explosion type mishaps, it is necessary to account for the combustible source, probable ignition source, resultant propagation, and observed damage. Any assumptions must be consistent with the fully established evidence and basic scientific principles.

Since most major aircraft mishaps involve ground impact, three types of fire/explosions must be considered. They are (a) fire/explosions in flight, (b) fire/explosions associated with ground impact; and (c) fire/explosions associated with sustained ground fires. Since several of the foregoing fire/explosion types will occur during most mishaps, a major role of the fire pattern investigator is to determine what damage was a result of what type of fire or explosion. This assessment is very difficult since most of the damaged components/skin, etc. will have been subject to several fire/explosion types. As an example, the ground fire damage may mask the damage on a particular component associated with an in-flight fire. An important objective of most

investigations is to determine if there was an in-flight fire/explosion. If so, where was it, where did it start, what was the initial fuel source, and what was the ignition source? Equally important, if it can be determined that fire/explosion was not the cause of the mishap, more emphasis may be placed on other disciplines to find the reason for the mishap.

(1) Combustible Source

Aircraft fires can involve various classes of combustibles, including ordinary combustible solids or dusts (Class A), combustible liquids or gases (Class B), combustibles of electrical equipment (Class C), and combustible metals (Class D). The class designation is the NFPA Code (Ref. 6) used in classifying fires and fire extinguishing systems. Thus, aircraft combustibles can be grouped as follows:

<u>Class A</u>	<u>Class B</u>	<u>Class C</u>	<u>Class D</u>
Cabin interiors	Turbine fuels	Energized elec-	Metal tubing
Baggage	Missile fuels	trical equipment	Control cables
Clothing	Hydraulic fluids		Structural metals
Tires/t bing	Lubricants/coolants		Metal equipment
Cargo solids	Alcohol		Cargo metals
	Cargo liquids		

The NFPA Code further classifies the liquids as Class I flammables (flash point below 100°F), Class II flammables (flash point at or above 100°F but below 140°F), and Class III combustibles (flash point at or above 140°F). Accordingly, if the fuel tank is below 100°F, the Class I aircraft liquid fuels should be considered the most likely suspects in a vapor-air explosion. It is important to realize that an explosion of a fuel vapor-air mixture will only occur if the fuel concentration falls within its limits of flammability.

Turbine jet fuels are potentially the major source of combustion in an aircraft fire although they are not always the fuel source in the initiation or ignition stage. They include high volatility grades (<100°F flash point) such as JP-4 or commercial Jet B, and low volatility grades (>100°F flash point) such as JP-5, JP-7, JP-8, or commercial Jet A. Other combustible fluids such as missile fuels, hydraulic fluids, and oil lubricants or coolants are of comparable or lower volatility than the Jet A type fuels. Where the mishap is evidenced by a flash-type fire or gaseous explosion, the high volatility fuels would be the prime suspects. However, all jet fuels and flammable fluids can display such rapid flame propagation when sufficiently heated or finely dispersed as a spray or exposed to low ambient pressures. Leaking gaskets, loose fittings, and ruptured lines or tanks can be evidence of the initial or primary source of combustible. Similarly, soot deposits can be indicative of hydrocarbon or organic fuels as a source. Both fire damage and combustion properties must be considered in determining the role of any combustible; flash points, ignition energies or temperatures, and limits of flammability are some of the more useful properties.

Other aircraft combustibles are composed of plastic, fabric, cellulosic, metallic, and other solid type materials. Generally, these materials become

involved in an aircraft fire after propagation of the initial fire, in the spread of a fuel fire to the cabin interior. However, they can be the initial or primary source of combustible in a few cases, such as a tire fire during landing, a cabin fire due to hostile gun firing, or a cabin fire due to unsafe use of oxygen masks. Their role in any fire can be determined from their spatial distribution, combustion properties, and contribution to the fire damage. The investigator should be especially aware of those materials which ignite readily, burn rapidly, or produce very high temperatures. The role of any exploding ordnance will be characterized by much more severe local and/or remote damage than that of the aircraft combustibles.

(2) Ignition Source

The ignition source in an aircraft mishap can be a mechanical, electrical, or chemical form of heat or energy. In a severe crash fire case, multiple ignition sources can be encountered, including hot engine fragments and the initial fireball itself. In any mishap, all possible heat or energy sources need to be considered. The main types of typical examples are cited below.

Hot Surfaces

Engines, pumps, or compressors overheated.
Electrical wiring, heaters, or motors overheated.
Frictional or aerodynamic surface heating.
Incendiary particles or hot metal fragments.

Hot Gas or Flame

Engine exhausts, bleed air, or hot jets of air, fuel vapors, or oil vapors
Open flames (matches, lighters, pilot flames, or afterburner plumes)
Adiabatic compressed gases.

Electrical Sparks or Arcs

Electrical wiring or equipment shorts.
Static electricity; lightning.

Frictional Sparks

Metal abrasions by turbines or rotating devices.
Metal abrasions from breakup of aircraft
Metal impacts from flying projectiles or aircraft crash.

Other Sources

Lasers; high radio frequency radiation.
Pyrophoric, hypergolic, or self-heating substances.
Items associated with sabotage.

In the list of ignition sources, a distinction is made between electrical and frictional ignitions that involve sparks or arcs and similar ignitions that involve only surface heating without sparks. Also, flames are included under hot gases since the former are high temperature gases, even though they are luminous and derived from combustion. The miscellaneous "other sources" are least likely to be encountered in aircraft fires but cannot be neglected entirely.

Generally, most ignitions are caused by hot surfaces or electrical-type sources; therefore, these sources should receive the greatest attention at the

outset and then compared to the other possibilities. Both the nature of the available ignition source and physical state of the suspect combustible can have a significant bearing. For example, spark ignition requirements of liquid fuels will be substantially lower for their vapors than for condensed vapors (sprays or mists); similarly, ignition energy or temperature requirements of solids will be much lower for finely divided forms than for bulk forms. Reference to the data on ignition properties is relevant to the characteristics and limitations of the various sources.

Since a sustained ignition (i.e., fire) requires a combustible and oxidant atmosphere, evidence on the combustible source can be helpful in determining the ignition location(s). The fire damage pattern throughout the aircraft is also relied upon in this connection. Such sources as electrical arcs, lightning, high impact metal sparks, and severe electrical or frictional heating are usually evident by severe and localized damage; this damage can occur with or without a fire. The other sources are more difficult to identify from the fire damage alone. To identify the ignition source, one should also establish when ignition probably occurred (e.g., in-flight vs. after a crash) and whether the assumed ignition event is consistent with the known fire damage and sequence of events.

Where no apparent ignition source is found, static electricity should be suspected. This source is usually a prime suspect in ignitions involving the loading or transfer of liquid fuels at high velocities.

(3) Fire Scenario

A fire scenario is formulated to describe the origin, propagation, and extinguishment of any fire or explosion in the mishap. The scenario is deduced from the accumulated evidence on the combustible source, ignition source, fire/explosion damage, and sequence of events. Witness accounts are used to help corroborate the fire evidence. A knowledge of flame spread rates of combustibles is helpful here in determining the temporal sequence of the fire.

Once ignition has taken place, the sustained propagation of any fire will necessarily be determined by the concentration, distribution, and properties of the combustibles and by the environmental conditions. Fires involving combustible metals normally will not spread rapidly unless the metals are finely divided or exposed to high air velocities, as in an in-flight fire. Cabin fires will be sustained by the flammable materials present (e.g., fabrics) and can result in flash propagation after the combustibles become heated and release large volumes of flammable vapors. Distribution of the combustibles should be carefully noted in establishing the growth of the fire.

Fires of liquid fuels can also result in flash propagations. Such propagations are often evident following the ignition of a large fuel spill. This hazard is greater for a high-volatile fuel (JP-4) than a low-volatile one (JP-8); however, the difference becomes small when the fuels are finely dispersed, as in a high impact aircraft crash where a large fireball occurs. Generally, the fire spread rate will be greatest where uniform flammable vapor-air mixtures can accumulate and produce an explosion, as opposed to a fire. Burning rates are accelerated by turbulence; however, flame propagation (velocity) may be either increased or decreased by ventilation air flow effects. It should be realized that a near-empty tank of JP-4 contains more vapor for an

explosion than a near-full tank. Of course, a damaged near-full tank can result in a much larger fire.

An in-flight fire exposed to an air stream may spread rapidly from the point of ignition to the aft part of the aircraft. In comparison, a ground fire will be characterized by an irregular or sporadic pattern of vertical and horizontal flame spread; vertical flame spread will predominate where a "chimney" ventilation path exists. The pattern of soot formation can also be helpful in determining the fire pattern. For example, the soot deposits from the combustion source will tend to follow the air stream and progressively decrease from the burning source; this indicates an in-flight fire, whereas other soot patterns may indicate they were formed after the aircraft disintegrated. Similarly, evidence on heat damage to the aircraft materials can provide clues to the progress of fire.

Extinguishment of the fire is included since a fire scenario is not complete until the end of the fire fighting and rescue operations. The adequacy of the agents, equipment, and procedures will reflect on the severity of the fire. Toxicity of all fire product vapors, including those of fire extinguishments and aircraft materials, is considered in assessment of the fire casualties.

When the fire scenario has been established, the investigator should characterize the specific type of fire accident. Causal factors and possible preventive measures should be included. The aircraft mishaps may be classified as follows:

- . Aircraft crash (no fire)
- . Aircraft crash (immediately followed by fire)
- . Aircraft crash (followed by fire but delay in ignition)
- . Aircraft fire in-flight (fire extinguished)
- . Aircraft fire in-flight (followed by crash and fire)
- . Aircraft fire on ground (no crash)
- . Aircraft fire in hangar (no crash)
- . Other types

(4) Damage Patterns

Damage in the accident will be largely attributable to the exposure of materials to excessive heat, pressure, or other mechanical force. Some of the general guidelines for uncovering such evidence are briefly summarized in this section. The sections on damage analyses at the end of this report provide greater discussion and many supporting data on this important assessment.

Fire damage depends greatly upon the intensity and duration of the heat source. The fire intensity can be determined from the known temperature limitations of the aircraft materials that were damaged. Melting points, softening points, ignition temperatures, and radiative thresholds for damage are used to estimate minimum fire intensities, whereas flame temperatures are more applicable to maximum intensities. Most aircraft materials cannot withstand the temperatures of a fully developed hydrocarbon or carbonaceous fuel-air fire (>2000°F); titanium and stainless steels are among the exceptions and tend to show damage only from in-flight or torch-like fires. Extensive deposits of soot

or char will usually be indicative of fuel-rich fires and low fire temperatures. The damage patterns will also depend upon the size, distribution, and flame spread rate of the combustibles and such environmental factors as pressure and ventilation rate. Flight crew casualties will depend upon their exposure to heat, toxic fire products, or vitiated air.

Damage to powered equipment can be attributable to mechanical or electrical malfunctions or exposure to the surrounding fire. Electrical fires that involve arcing will display the most severe localized damage, similar to that of metal welding; others will produce heat damage of much less intense heating. Severe material damage is also found in fires with incendiaries, magnesium, or other high-energy combustibles. Where fires occur in an oxygen-enriched environment, even the most fire-resistant materials can be greatly consumed, depending upon the fire duration.

Explosion damage is basically caused by high pressure forces that are generated by the exploding source; combustible gas explosions also generate high temperatures which can, therefore, initiate a subsequent fire. As a rule of thumb, the maximum pressures for fuel vapor-air explosions (deflagrations) will be approximately eight times the initial pressure at ideal fuel concentrations. Aircraft fuel tanks and compartments cannot contain such explosions but may safely contain low order reactions with and without any venting. Thus, each fuel tank must be considered individually. The severest damage in gaseous explosions will be found with systems of high pressure, high oxygen content, or strong confinement. Depending upon the exploding source, the explosions may or may not leave soot or other thermal evidence.

The aircraft explosion damage will be indicated by the rupture of compartments or containers, fragmentation of containment materials, and dispersal of fragments. Pressure limitations of the exploding containers and their fasteners can be estimated from the tensile strengths and other available data on material mechanical properties. The blast wave pressure limitations (far-field effects) of damaged materials can be estimated from available field data and TNT explosive equivalencies. Metal fractures should be examined for the type of fracture, i.e., tension, compression, shear, etc. A tension failure would be typical for a gaseous deflagration, whereas a shear failure would be more typical for detonations of highly energetic systems, including explosives. The severity and relative location of all damage are crucial to development of the accident scenario. This should include both material and biological damage.

(5) Material Analyses

Chemical or physical analyses are often required to substantiate the damage evidence. This can include gas chromatography, mass spectrometry, or other analytical methods to define chemical compositions of gases, liquids, and solids; vapor pressure, flash point, boiling point, and distillation determinations for volatility properties of liquid combustibles; hardness, heat distortion, shear, tension, and compression strength for metallurgical properties of structural materials; X-ray, electron microscopic, or metallographic analyses for structural properties of solid materials; and other determinations of interest. The test samples should be truly representative of the suspect materials and should be properly packaged to avoid contamination, leakage, or breakage. Also, they should be tagged and identified with such information as

to their date, source, location, and manufacturer's batch or serial number; the aircraft type, serial number, and manufacturer should be included.

ASTM or other recognized methods should be specified for conducting the material analyses. The following technical orders (TO) provide detailed instructions on fluid sampling:

- . TO 41B-1-1 - Quality Control of Fuels and Lubricants, Para 4-10, Fuel and Oil Samples from Crashed Aircraft.
- . TO 42B2-1-3 - Fluids for Hydraulic Equipment.
- . TO 42B2-1-9 - Spectrometric Oil Analysis Program.

5. Conclusions and Report

In the final analysis, all direct and indirect evidence is reviewed for accuracy and reliability and the most plausible scenario is formulated for the sequence of events and cause(s) of the mishap. Any hypotheses proposed to explain the mishap should be logically and technically consistent with the established evidence. A proper analysis will require consideration of both material and human factors. To complete the investigation, the investigator should prepare a summary report on the mishap. The report should include pertinent background information, description of the mishap, accounts of witnesses, evidence from mishap site inspection, analysis of evidence, and development of mishap scenario to explain the probable cause of the mishap. In addition, recommendations should be made on what changes in equipment or procedures will help to prevent recurrence of the same mishap. The adequacy of equipment or procedures for fire detection, fire fighting, and rescue operations should also be appraised in the report.

AFR 127-4 (Ref. 2) requires that analysis drawn from witness statements be placed in Part II of the mishap safety report. The investigator's personal observations of the wreckage and other analysis drawn from physical evidence may be included in Part I of the report.

III. PROPERTIES OF AIR ENVIRONMENT

A. AIR ATMOSPHERE PROPERTIES

Atmospheric air is a major source of oxygen for sustaining combustion in most aircraft fires or explosions. Table 1 gives the composition of air (dry basis) at sea level and some of the physical properties of each component, including molecular weight, density, specific gravity (air = 1), and specific heat. For the purpose of this report, the air composition by volume can be taken as 20.95% oxygen, 78.1% nitrogen, and 0.95% argon plus carbon dioxide; also, the air density is 0.0765 lb/ft.³ (1.226 g/l) at 60°F and 0.0807 lb/ft.³ (1.293 g/l) at 32°F and 1 atmosphere pressure. Since air can be considered an ideal gas, the mole or volume percent ($\% X_i$) of any gas component is

$$\% X_i = 100 n_i/N = 100 P_i/P \quad (1)$$

where N is total moles, P is total pressure, n_i is moles of i^{th} component, and P_i is partial pressure of i^{th} component. Thus, the oxygen partial pressure of atmospheric air (1 atm) is 3.08 psia (14.7 psia x 20.95%/100).

Within the earth's troposphere, the air composition is relatively uniform with increasing altitude even though corresponding temperatures and densities decrease noticeably. Data for a standard atmosphere is given in Table 2 for up to 60,000 ft.; this atmosphere closely corresponds to that defined by NACA or ICAO. For some problems, it is desirable to have a functional relationship between pressure and altitude. A reliable empirical expression is

$$P = 14.696 \text{ EXP } (-3.66 \times 10^{-5} A - 1.21 \times 10^{-10} A^2) \quad (2)$$

where P is pressure (psia) and A is altitude (ft.). Calculated values by this expression are included in Table 2.

The data given throughout this report may be converted to various English or metric (SI) units by use of the conversion factors given in the Appendix. Basic SI units were taken from an ASTM Metric Practice Guide.

B. THERMODYNAMIC GAS LAWS

Thermodynamic laws are essential in defining the heat or energy change (work) of a system. The thermodynamic state of a gaseous system (fixed composition) can be defined in terms of volume (V) and absolute pressure (P) and temperature (T). For ideal gases, the equation of state is

$$PV = nRT \quad (3)$$

where n is number of moles and R is a universal gas constant whose value depends upon the P-V-T units. If the units are English with P in lb/ft.², V in ft.³, and T in °R (°F + 460), the universal gas constant is 1,545 ft-lbs/lb mole - °R; if the units are in atmospheres, liters, and degrees Kelvin (°C + 273), R will be equal to 0.08205 liter-atm/g mole - °K or 1.987 cal/g mole - °K. The specific gas constants (R/M) for various representative gases

TABLE 1 COMPOSITION AND PROPERTIES OF DRY AIR*

Constituent	Mol. Wt.	Density (32°F)		Specific Gravity (air = 1)	Specific Heat (70°F) Btu/lb - °F	Content Vol. %
		lb/ft. ³	g/l			
Nitrogen	28.01	0.0781	1.251	0.968	0.249	78.09
Oxygen	32.00	0.0892	1.429	1.105	0.219	20.95
Argon	39.94	0.1114	1.784	1.380	0.124	0.93
Carbon dioxide	44.01	0.1234	1.977	1.529	0.200	0.033
Air	28.97	0.0807	1.293(32°F)	1.000	0.240	100.0
		0.0766	1.227(60°F)		0.240	

* References 7 and 8.

TABLE 2 STANDARD AIR ATMOSPHERE*

Altitude ft.	Temperature °F		Pressure psia	Pressure** psia	Density lb/ft. ³
	°F	°C			
0	59	15	14.696	14.696	0.0765
1,000	55.4	13	14.175	14.166	0.0743
2,000	51.9	11	13.664	13.652	.0721
3,000	48.3	9	13.168	13.153	.0700
4,000	44.7	7	12.692	12.670	.0679
5,000	41.2	5	12.225	12.201	.0659
6,000	37.6	3	11.778	11.747	.0640
7,000	34.0	1	11.341	11.307	.0620
8,000	30.5	-1	10.914	10.881	.0601
9,000	26.9	-3	10.501	10.469	.0583
10,000	23.3	-5	10.108	10.069	.0565
15,000	5.5	-15	8.291	8.259	.0481
20,000	-12.3	-24	6.753	6.734	.0408
25,000	-30.2	-34	5.452	5.457	.0343
30,000	-48.0	-44	4.362	4.396	.0286
35,000	-65.8	-54	3.458	3.520	.0237
40,000	-67.0	-50	2.721	2.801	.0187
45,000	-67.0	-50	2.141	2.216	.0147
50,000	-67.0	-50	1.690	1.742	.0116
55,000	-67.0	-50	1.331	1.351	.0091
60,000	-67.0	-50	1.046	1.058	.0072

* Reference 8, comparable to ICAO standard atmosphere.

** Calculated by $P = 14.696 \text{ EXP } (-3.66 \times 10^{-5} A - 1.21 \times 10^{-10} A^2)$; where P (PSIA) is pressure and A (ft.) is altitude.

are included in Table 3, which summarizes some thermodynamic properties. Equation 3 can also be written as

$$PV = \frac{WRT}{M}; \quad n = \frac{W}{M} \quad (4)$$

or

$$\rho = \frac{PM}{RT}; \quad \rho = \frac{W}{V} \quad (5)$$

where W is weight (lbs.) M is molecular weight (lbs.) and ρ is density (lb/ft.³) of the gas. For example, the air density at 60°F (520°R) and 1 atmosphere is as follows:

$$\rho = \frac{2,116 \text{ lb/ft}^2 \times 29 \text{ lbs.}}{1,545 \times 520^{\circ}\text{R}} = 0.0764 \text{ lb/ft.}^3$$

Note that this value agrees with the data of Tables 1 and 2. The gas densities may also be calculated by use of the molecular weights and molecular volumes in Table 3. For example, the air density at 32°F (492°R) and 1 atmosphere is

$$\rho = \frac{29 \text{ lbs.}}{359 \text{ ft.}^3} = 0.0808 \text{ lb./ft.}^3$$

or

$$\rho = \frac{29 \text{ g}}{22.414 \text{ l}} = 1.294 \text{ g/l}$$

A molar volume of 22.414 l or 359 ft.³ can be assumed as a constant for most gaseous materials at standard temperature (32°F) and pressure (1 atm).

At high pressures or very low temperatures, real gases deviate from ideal behavior and require a modified equation of state that includes a compressibility factor for characterizing their state. Critical temperatures and pressures above which the gases cannot be liquified are included in Table 3.

In the compression or expansion of gases, the heat or energy change will depend upon the conditions under which the work process occurs. If the process is isothermal (constant temperature), the total work is defined as follows:

$$\text{Work} = n RT \ln V_2/V_1 = n RT \ln P_1/P_2; \quad P_1V_1 = P_2V_2 \quad (6)$$

For an adiabatic (isentropic) process (no gain or loss of heat):

$$\text{Work} = n C_v T_1 [1 - (P_2/P_1)^{R/C_p}]; \quad P_1V_1^\gamma = P_2V_2^\gamma \quad (7)$$

where C_v and C_p are molar heat capacities (specific heats), γ is C_p/C_v ratio, and their subscripts refer to constant pressure (p) or constant volume (v). The temperature change for the adiabatic process is:

$$T_2/T_1 = (V_1/V_2)^{\gamma-1} = (P_2/P_1)^{\frac{\gamma-1}{\gamma}} \quad (8)$$

The gas constant R is equal to $C_p - C_v$ for ideal gases. The C_p/C_v ratio is approximately 1.4 for air and diatomic gases at standard or normal temperatures

TABLE 3 PHYSICAL PROPERTIES OF GASES¹

Gas	Formula	Mol. Wt. (M) lb/lb mole	Mol. Vol. ² ft ³ /lb mole	Specific Gas Constant (R/M) ³ ft ² /OR	Specific Heat ⁴			Critical Temperature OF	Critical Pressure atm
					C _p		C _v		
					Btu/lb -OF	Btu/lb OF	C _p /C _v		
Air	-	28.97	359.0	53.35	0.240	0.171	1.40	-221.3	37.2
<u>Monatomic Gases</u>									
Argon	A	39.94	359.6	38.68	0.123	0.074	1.67	-187.7	48.0
Helium	He	4.003	359.2	386.2	1.25	0.75	1.66	-450.2	2.26
<u>Diatomic Gases</u>									
Carbon monoxide	CO	28.01	358.8	56.18	0.249	0.178	1.40	-218.2	35.0
Hydrogen	H ₂	2.016	359.3	766.6	3.42	2.43	1.41	-399.8	12.8
Nitrogen	N ₂	28.02	358.9	55.16	0.248	0.177	1.40	-232.8	33.5
Oxygen	O ₂	32.0	358.7	48.29	0.219	0.156	1.40	-181.8	49.7
<u>Triatomic Gases</u>									
Carbon dioxide	CO ₂	44.01	356.6	35.12	0.202	0.156	1.30	88.0	73.0
Sulfur dioxide	SO ₂	64.07	350.6	24.12	0.154	0.122	1.26	315.0	77.7
Water vapor	H ₂ O	18.02	-	85.78	0.446	0.336	1.33	705.5	218.5
<u>Hydrocarbons</u>									
Acetylene	C ₂ H ₂	26.04	355.6	59.35	0.383	0.303	1.26	103.5	62.0
Methane	CH ₄	16.04	358.0	96.35	0.532	0.403	1.32	-116.5	45.8
Ethane	C ₂ H ₆	30.07	355.1	51.40	0.419	0.342	1.22	90.1	48.2
Isobutane	C ₄ H ₁₀	58.12	348.2	26.59	0.398	0.358	1.11	273.2	36.9

¹ Data mainly from U. S. Department of Commerce, Bureau of Standards Circular No. 461, and from Eshbach, Handbook of Engineering Fundamentals, New York, Wiley, 1936.
² Data for 1 atm and 32°F.
³ Universal gas constant (R) taken as 1545.3 ft.lb/lb mole - °R or 1.986 Btu/lb mole - °R.
⁴ Data for 1 atm and room temperature.

and pressures. These equations are of interest in dealing with both combustible and noncombustible systems. Figure 5 shows the pressure-volume changes that can be expected in the adiabatic and isothermal compression of air. The temperature changes in the adiabatic compression process can be very high and are discussed under compression ignition hazards of aircraft combustibles.

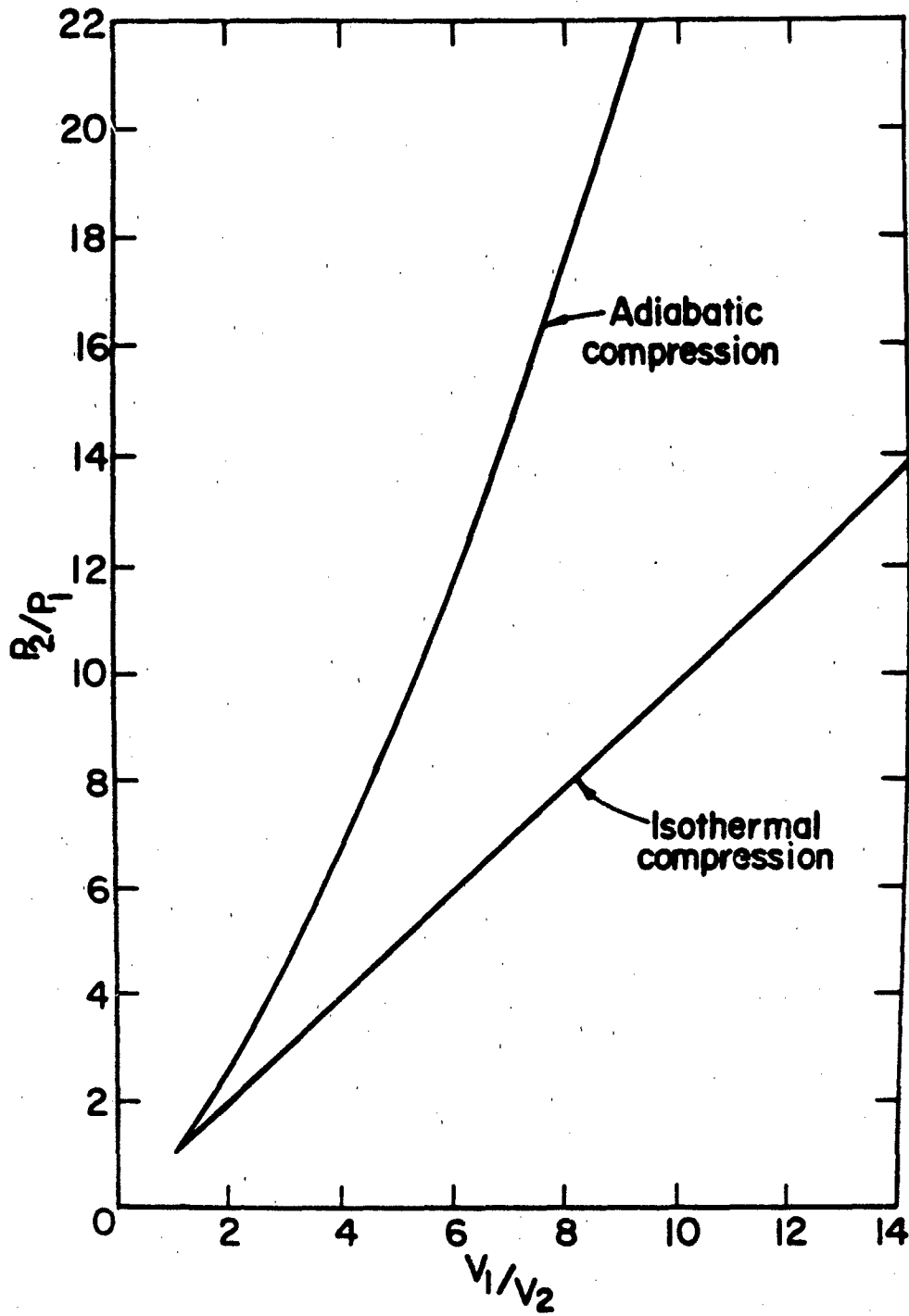

Figure 5. Variation of Pressure Ratio (P_2/P_1) with Volume Ratio (V_1/V_2) in Adiabatic and Isothermal Compression of an Ideal Gas

IV. PROPERTIES OF AIRCRAFT COMBUSTIBLE LIQUIDS OR GASES

This section summarizes selected physical and combustion properties of aircraft turbine fuels, missile fuels, hydraulic fluids, engine oils, lubricating fluids, and miscellaneous liquid or gaseous combustibles. These data are typical or accepted values for the specified fuel or fluid, whose actual composition will vary with the product source but within the limits of the military or civilian agency specifications. Thus, the reported properties for a given fluid can be expected to display some variation due to composition differences, as well as differences in test methods.

The aircraft jet or turbine fuels basically consist of kerosene fractions (low volatility) or kerosene blends with lighter fractions (high volatility). The low volatility grades are commercial Jet A or Jet A-1, JP-5, JP-6, JP-7, and JP-8; JP-8 properties are very similar to Jet A or Jet A-1, and JP-7 properties are comparable to those of JP-5. The U. S. Navy uses the JP-5 fuel. High volatility grades are commercial Jet B and JP-4, which have essentially the same properties. The U. S. Air Force uses JP-4 and JP-8 in normal operations and JP-7 and TS (thermally stable) in special applications. All of the fuels have wide temperature ranges of distillation and relatively low freezing points. Typical volatility properties are given in Table 4 for both aircraft and missile fuels.

TABLE 4 TYPICAL VOLATILITY PROPERTIES OF AIRCRAFT FUELS AND MISSILE FUELS*

Fuel	Freezing Point °F	Flash Point °F	Distillation Range °F	Reid Vapor ** Pressure (100°F) psia
<u>Aircraft Fuels</u>				
Av Gas 100/130	<-76	-49	104-298	6.67
Jet B	<-76	<0	132-483	2.60
JP-4	<-80	<0	142-456	2.60
Jet A	-51	>105	331-512	0.20
Jet A-1	-59	>115	329-501	0.20
JP-8	-65	>115	331-512	0.20
JP-7	-47	>140	372-484	0.087
JP-5	-56	>140	364-506	0.087
TS	-71	>110	320-478	-
<u>Missile Fuels</u>				
JP-9	-65	73	210-563	-
JP-10	-110	127	405	-
RJ-4	-40	160	405-430	-
RJ-5	0	219	500-545	-
RJ-6	-65	142	360-545	-

* Data from references 9 and 11.

** Equal values assumed for fuels of comparable flash points.

Missile fuels are a special category for use in air-breathing ramjet or turbine engines. These fuels consist of hydrocarbons, such as cyclopentadienes, which are typically characterized as high temperature fuels. Their freezing points and volatility are somewhat like those of low volatility jet fuels. The RJ-4, RJ-5, and RJ-6 fuels are for ramjet missiles and the JP-9 and JP-10 fuels for turbine missiles.

Table 5 summarizes some of the combustion properties that are important in evaluating the fire and explosion characteristics of aircraft fuels and missile fuels. Table 6 gives similar data that are available for hydraulic fluids and lubricating fluids. These and other pertinent data are discussed in the following sections.

A. DENSITIES AND SPECIFIC GRAVITIES

Density of a substance is defined as mass per unit volume and decreases with increasing temperature. This is illustrated in Figure 6 (Ref. 9) for the liquid densities of aircraft fuels and missile fuels. Tables 5 and 6 give the densities in terms of specific gravity which is the ratio of the density of the substance to that of water (62.4 lbs/cu.ft.). For gases, the specific gravity usually is given with reference to the density of air (see table in Appendix A).

B. FLASH POINTS AND VAPOR PRESSURES

The flash point of an aircraft combustible liquid defines the minimum temperature at which the liquid evolves sufficient vapor to form a flammable mixture with air near the surface of the liquid or within its container. Thus, flash point depends upon the volatility (vapor pressure) of the liquid as well as flammability (concentration limits) of its vapors in the temperature - pressure environment. Note the strong relationship between flash point and Reid vapor pressure in Table 4 for the aircraft fuels. True vapor pressures of various aircraft fuels and missile fuels are shown as a function of temperature in Figure 7 (Ref. 1) or reciprocal temperature in Figure 8 (Ref. 9). Reid vapor pressure (RVP) is defined as the vapor pressure at 100°F and is used in fuel specifications as indicated in Figure 7; the JP-4 specification includes RVP values between 2.0 and 3.0 psia.

It is useful to include flash points in such plots, as done in Figure 7, for estimating the minimum fuel vapor concentration that can be flammable, i.e., the lower flammable limit of the given fuel. For example, at an assumed flash point of 100°F for JP-6,

$$\text{Lower limit} = 100 p_f/P_t = 100 \left(\frac{0.1}{14.69} \right) = 0.68 \text{ vol.}\% \quad (9)$$

where p_f is fuel vapor pressure (0.1 psia) and P_t is the total pressure (14.69 psia). Closed cup flash points (ASTM D56 or D93) are the most reliable values and apply to a closed system at near-equilibrium conditions; higher flash points result when the system is open and subject to convection and dilution of the flammable volume. Since flash points are determined in the downward propagation mode, they underestimate the possible hazard for upward flame propagation. Aviation gasoline (AvGas) is the highest volatility fuel

TABLE 5 - SUMMARY OF COMBUSTION PROPERTIES OF JET FUELS AND GASOLINES¹
 (Gaseous Combustion in Air at Atmospheric Pressure)

Fuel	Mol. Wt. (liquid)	Sp. Gr. @ 70°F (water=1)	B. Pt. 90% °C	C _{st} ² in air vol-pct	Net Heat of Combustion Btu/lb cal/g	Flash Point °C °F	Minimum AIT °C °F	Flammable Limits ³	
								L	U
<u>Aircraft Fuels</u>									
JP-4	125 ⁴	.76	220 428	2.4	18,710 10,395	-18 0	230 446	1.3	8.2
JP-5	169	.81	238 460	1.1	18,440 10,245	66 150	225 437	.6	4.5
JP-6	147	.84	260 500	1.3	18,620 10,345	38 100	230 446	.7	4.8
JP-7		.79	232 450	1.1	18,800 10,445	>60 140	241 465	.6	4.5
JP-8	164	.82	250 482	1.1	18,400 10,225	46 115	225 437	.6	4.7
Jet A		.82	250 482		18,590 10,328	>40 105	225 437	Similar to JP-8	
Jet B		.76	220 428		18,780 10,435	<-18 0	230 446	Similar to JP-4	
TS (thermally stable)		.78	222 432		18,400 10,225	>43 109			
Kerosene (typical)		.8	254 490	1.3	18,600 10,335	52 125	230 446	.7	4.8
Gasoline 100/130		.7	116 240	2.4	19,000 10,555	-45 -49	440 824	1.3	7.1
Gasoline 115/145		.7	120 248	2.2	19,000 10,555	-45 -49	470 878	1.2	7.1
Diesel Fuel (60 cetane)		.8	325 617				225 437		
<u>Missile Fuels</u>									
JP-9	138	.95	260 500		18,090 10,050	23 73	250 482		
JP-10	136	.94			18,100 10,055	53 127	245 473		
°J-4		.93			18,140 10,075	71 160	52 624		
RJ-5		1.08			17,760 9,865	104 219	234 453		
RJ-6		1.02			17,700 9,830	61 142	232 450		

1 Data from references 1 and 9.
 2 Calculated values by C_{st} = L₂₅/0.55; C_{st} is stoichiometric fuel concentration for complete combustion.
 3 Limits at 25°C (77°F) or above flash point.
 4 Mol. Wt. = 78 at 70°F for fractionated vapor.

**TABLE 6 SUMMARY OF COMBUSTION PROPERTIES OF
 HYDRAULIC FLUIDS AND LUBRICATING OILS***

Fluid	Sp. Gr. (Water=1)	Net Heat of Combustion Btu/lb.	Flash Point		Fire Point °C	Minimum AIT	
			°C	°F		°C	°F
Mineral Oils or Hydrocarbons							
MIL-R-5606 (oil)	0.85	18,240	90	194	107	225	437
MIL-2190 (oil)	.86		232	500		350	662
MLO-60-294 (oil)	.88		196	385	221	370	698
Mobil DTE-103 (oil)	.92		199	390		370	698
MIL-R-83282 (synthetic)	.84	17,870	196	385		354	670
Pyrogard D (invert emulsion)						>315	600
Glycols							
Propylene glycol		9,350	110	230	113	445	833
Houghto-Safe 271 (water-glycol)	1.05					410	770
Ucon 50 HB-260 (polyglycol)	1.04		235	455	260	395	743
Phosphate Esters							
Cellulube 220 (ester base)	1.15		235	455	352	560	1040
Skydrol 500B (ester base)	1.06	12,800	182	360	243	510	950
Pydraul 150 (ester base)	1.13		193	380	243	525	977
Pydraul AC (ester base)	1.35		232	450	396	595	1103
Houghto-Safe 1055 (aryl ester)	1.15		263	505	360	550	1022
Tricresyl phosphate	1.17		243	470		600	1112
Polyol and Dibasic Acid Esters							
MIL-L-7808 (acid diester)		14,790	225	437	238	390	735
MIL-L-9236 (polyol ester)			221	430	246	390	735
MIL-L-23699B (polyol ester)	.99	13,060	227	440		385	725
MLO-54-581 (acid diester)			224	435	246	390	735
Flexol 201 (acid diester)	.91		216	420	232	380	715
Silanes							
MLO-56-280 (diphenyl-dodecyl)			291	555	329	415	780
MLO-56-610 (decyl-dodecyl)			279	535	302	400	752
Silicates and Silicones							
MLO-54-540 (silicate)			163	325	221	375	707
MLO-54-856 (silicate)			157	315	227	380	715
Oronite 8200 (silicate)	.93		196	385	227	380	715
Versilube F-50 (silicone)	1.05		288	550	338	480	895
Dow Corning 400 (siloxane)			124	255	138	320	608
Dow Corning 500 (siloxane)	<.95		243	470		480	895
Dow Corning 550 (silicone)	1.07		316	600			
Chlorinated Silicones and Hydrocarbons							
MLO-53-446 (silicone)			304	580	377	420	788
Arachlor 1248 (diphenyl)	1.41		193	380	>315	640	1185
Pydraul A-200 (hydrocarbon)	1.42		177	350	360	650	1202
Halocarbon A08	1.84	2,390	>482	900	-	632	1170
Aromatic Ethers							
SP4E (polyphenoxy)			293	560	349	610	1130
OS-124 (polyphenyl)	1.20		288	550	349	600	1112
MCS-293	1.19		220	428	270	490	915
Miscellaneous Fluids							
SAE No. 10 lube oil	<1.0		171	340	193	380	715
SAE No. 60 lube oil	<1.0		249	480	327	380	715
Linseed oil	.95		224	435	279	440	825

* Data from references 1 and 10.

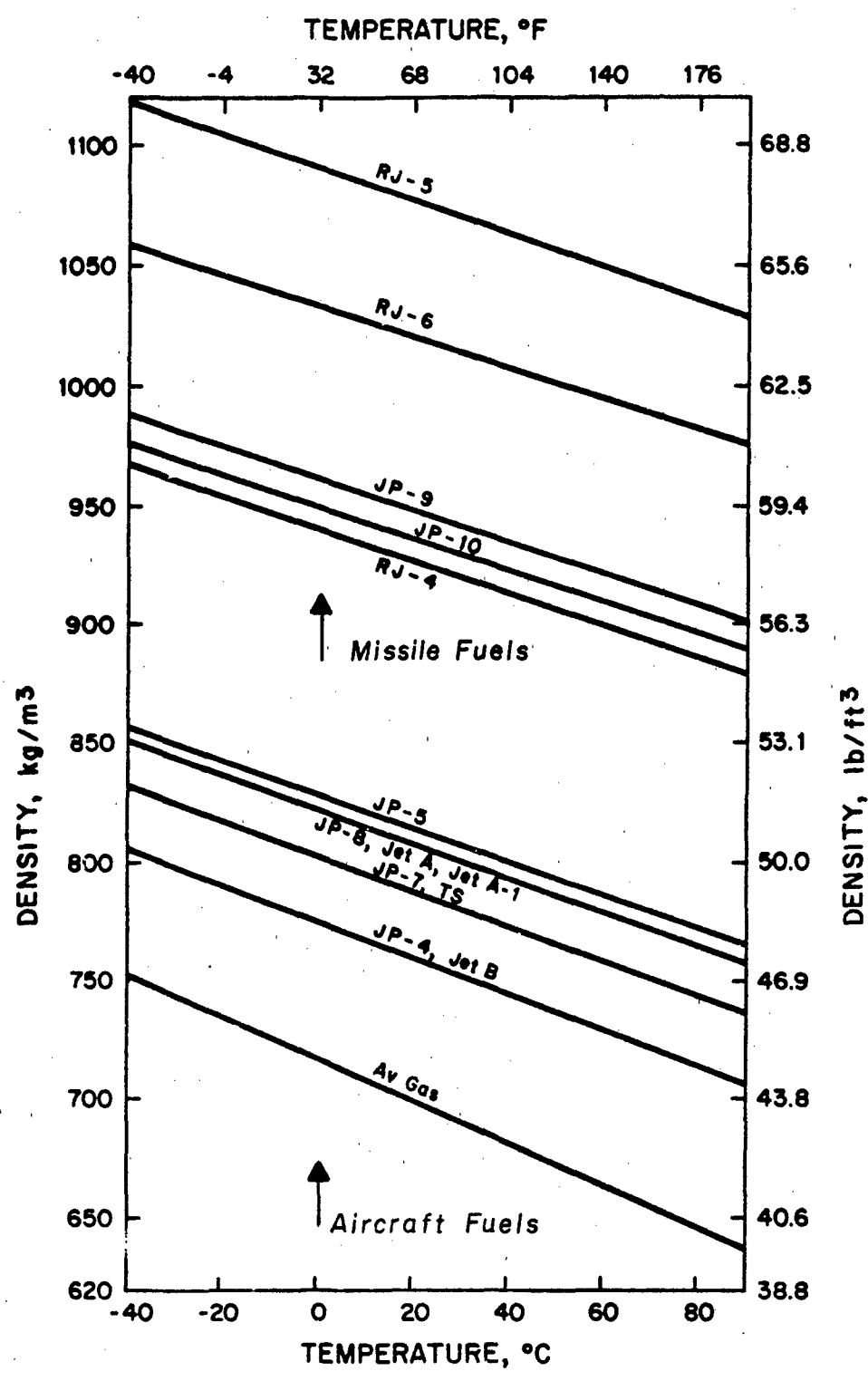

Figure 6. Density Versus Temperature for Aircraft Fuels and Missile Fuels

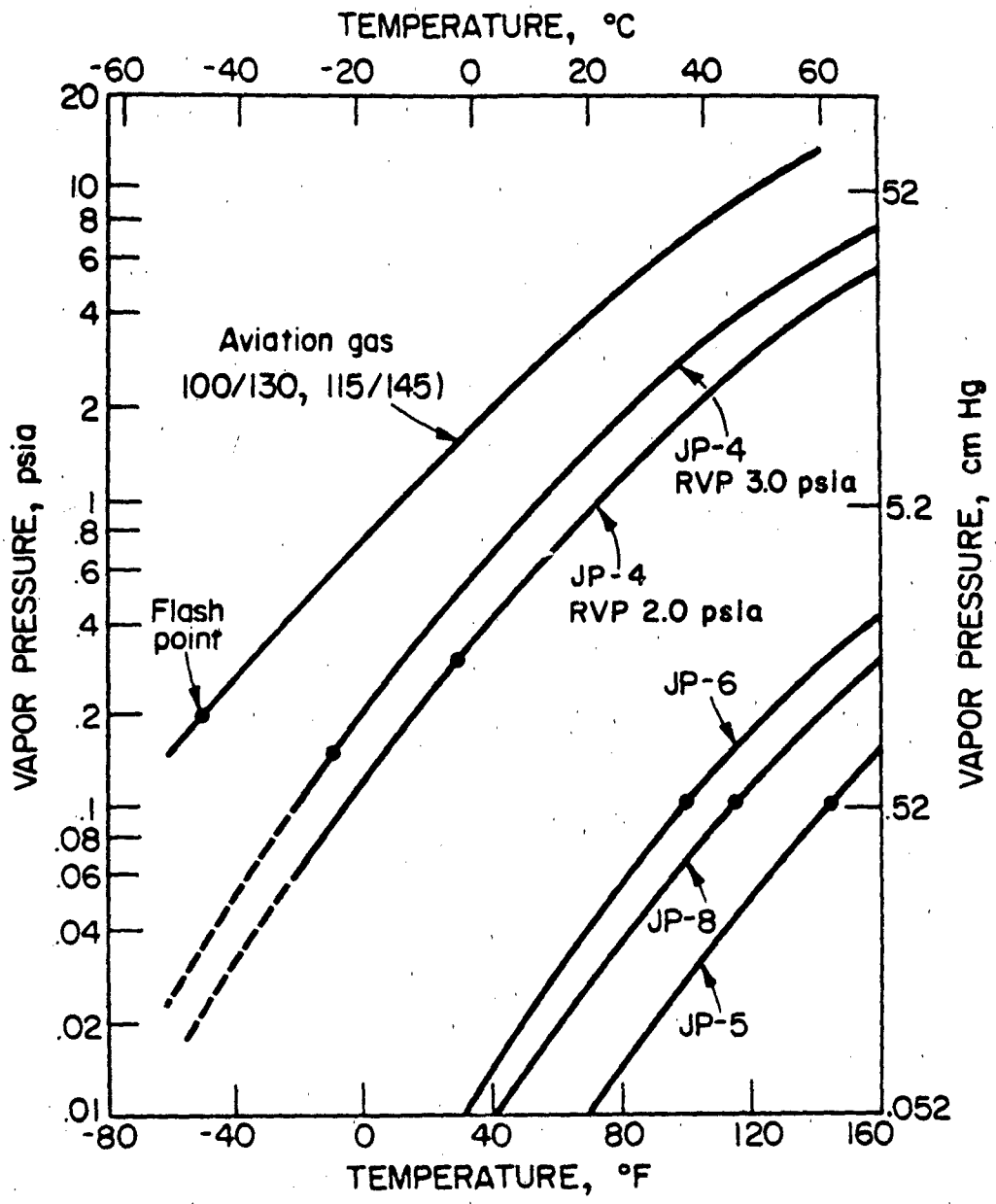

Figure 7. Vapor Pressure Versus Temperature and Approximate Flash Points for Aviation Gasoline and Various Aircraft Jet Fuels

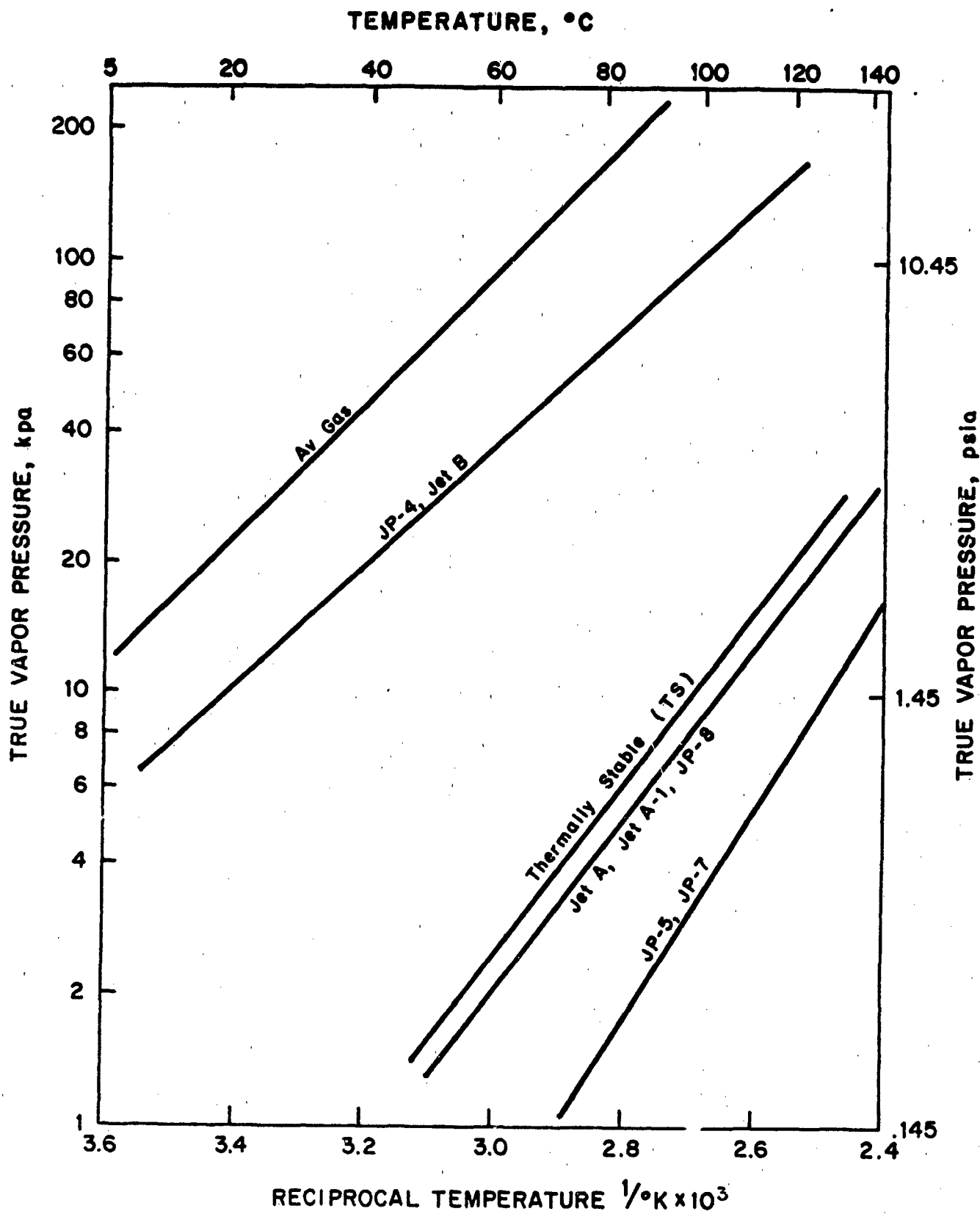

Figure 8. True Vapor Pressure Versus Temperature or Reciprocal Temperature for Aviation Gasoline and Various Aircraft Jet Fuels

since it consists largely of the lighter ends of the petroleum distillate. It is primarily used in reciprocating aircraft engines.

Both flash point and fire point data are given for the hydraulic fluids and lubricating oils (Table 6). The fire point is the liquid temperature at which flame can be sustained after the vapors are ignited; differences between flash and fire points tend to increase with decreased volatility and increased fire resistance of the fluid. Generally, the flash points of oils, lubricants, and hydraulic fluids are noticeably higher than for aircraft fuels. In the case of water-glycols, flash points will not exist until the excessive water has been evaporated. If the fluids are in the form of mists or sprays, flammable mixtures are possible even below the flash points; however, ignition energy requirements are high compared to those for vapor mixtures. This subject is discussed more fully under the sections on flammability limits and ignition energies.

Where fuel blends and contaminated fuels are involved, the flash point will be strongly influenced by the liquid mixture component of highest volatility. For example, the flash point of Jet A in Figure 9 is reduced by about 50°F with the addition of 10 percent of Jet B (Ref. 9); equivalent results would be expected in the dilution of JP-8 with JP-4. However, if the additive is a highly volatile extinguishant, the flash point will be increased.

C. LIMITS OF FLAMMABILITY IN AIR

The ability of a liquid fuel to form flammable vapor-air mixtures can be defined in terms of temperature and concentration limits. This is illustrated in Figure 10 for the high volatile JP-4 fuel and Figure 11 for the low volatile JP-5 fuel (Ref. 1). The lower temperature limit (T_l) is the minimum liquid fuel temperature at which sufficient fuel vapor is evolved to form a flammable mixture when uniformly mixed with air; this temperature is usually slightly lower than the flash point which is apparatus-dependent. The upper temperature limit (T_u) corresponds to the fuel temperature above which the equilibrium concentration of saturated vapor-air mixtures is too rich to form flammable mixtures. These temperature limits can widen when fuel mists or sprays are formed under dynamic or nonequilibrium conditions, as in a fuel spill or agitated fuel tank. Pressure or altitude effects on these limits are shown in Figures 12 and 13, which are discussed later.

The minimum and maximum fuel vapor concentrations which can form flammable mixtures with air are referred to as the lower limit (L) and upper limit (U) of flammability. By definition, a flammable mixture is one which when ignited will propagate flame beyond the influence of the ignition source (e.g., electric spark). These concentration limits will vary with temperature, pressure, directional mode of propagation, ignition source energy, and heat losses to the physical surroundings. As noted in Figures 10 and 11, the limits are widened by increasing temperature and that autoignitions can result when the fuel temperature becomes excessive. Limits of flammability are primarily applicable to premixed type flames in which uniform fuel vapor-air mixtures are present, as in a gaseous explosion. They are not applicable to diffusion type flames which have no uniform fuel vapor concentrations, as in a fire situation. The main characteristics of a premixed hydrocarbon-air flame are as follows:

- (1) Rapid exothermic reaction - about 10 kcal/g-mole (18,000 btu/lb.mole) for a limit gas mixture.

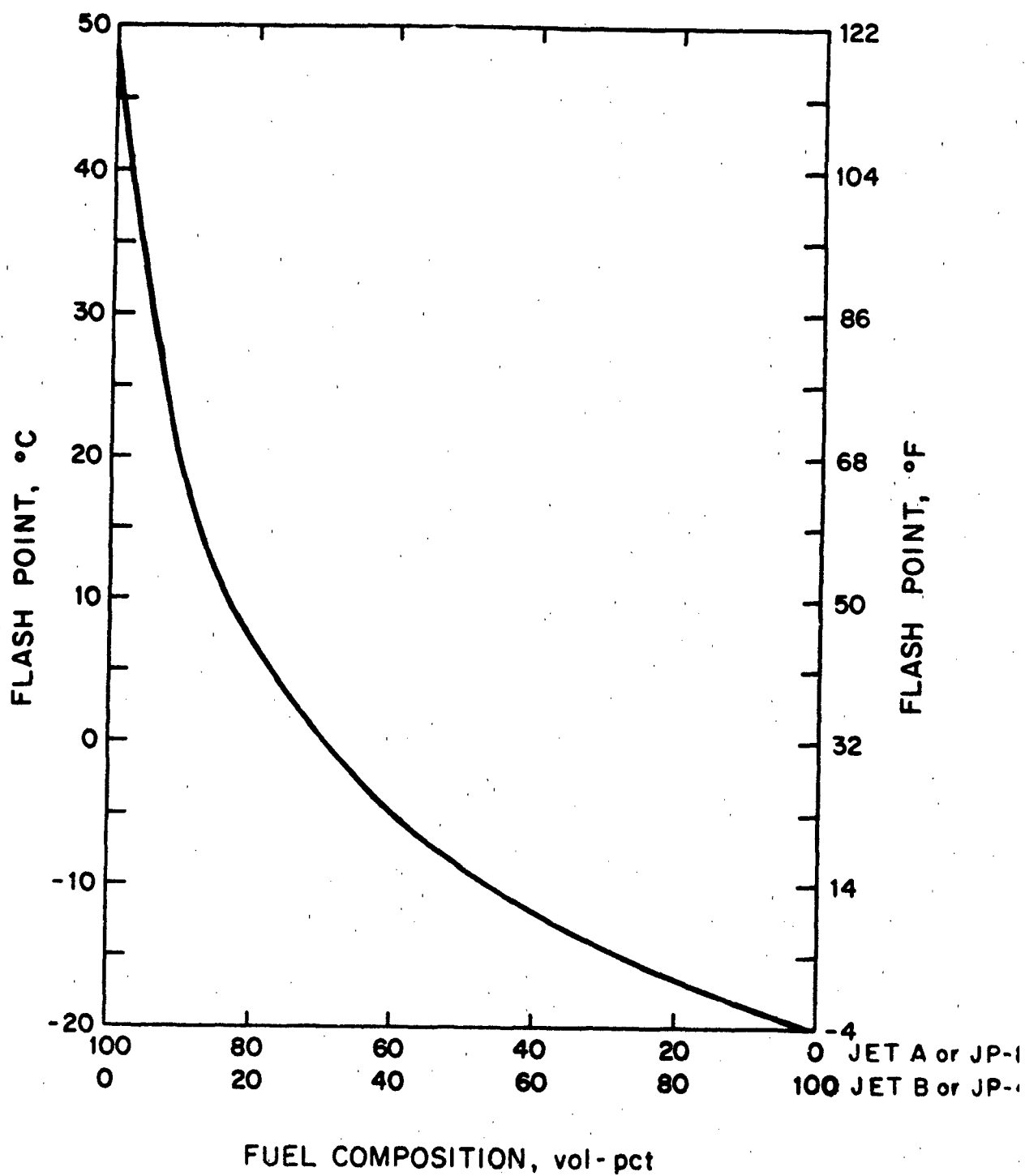

Figure 9. Flash Point of Blends of Jet A or JP-8 and Jet B or JP-4 Type Fuels

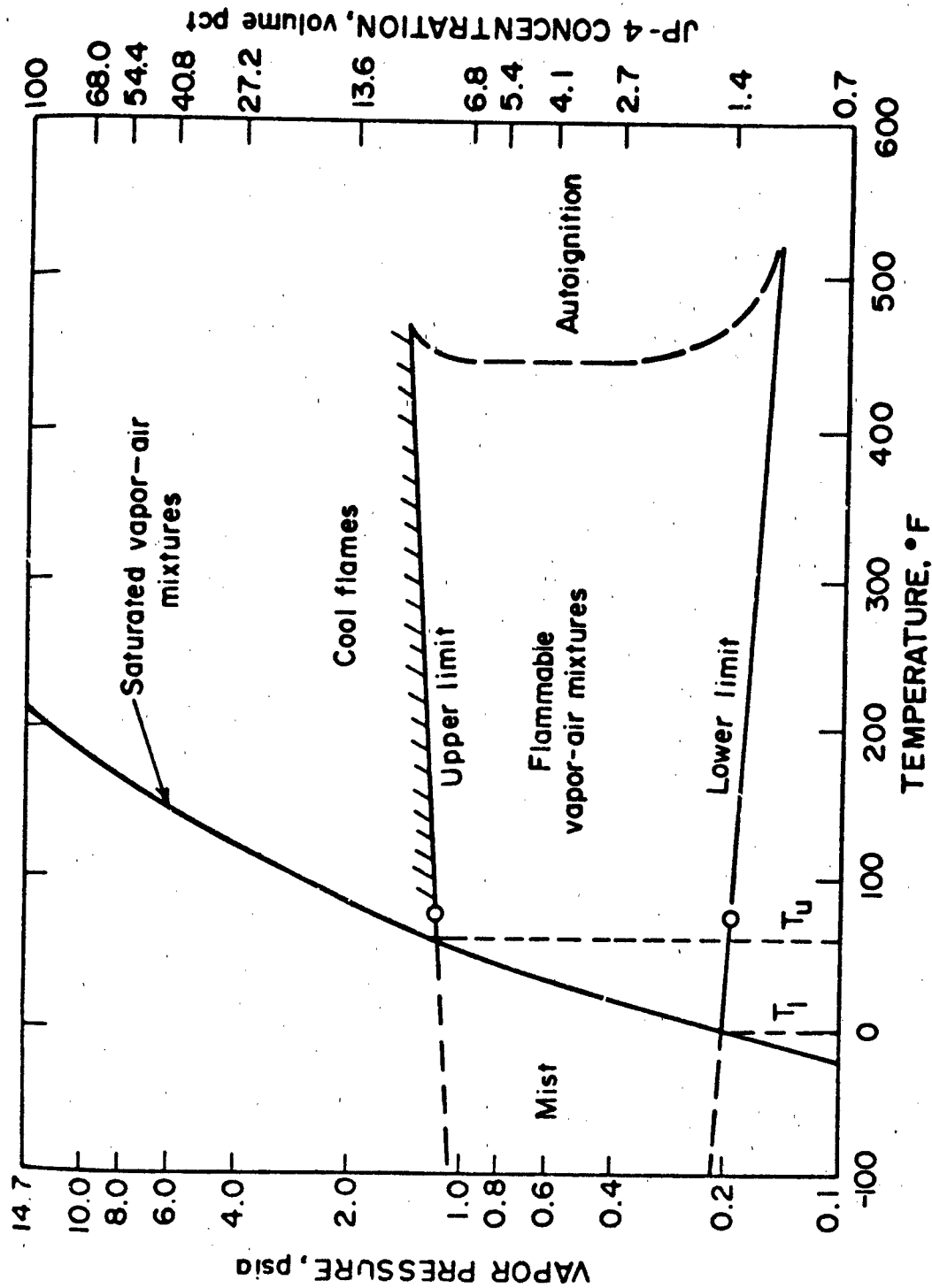

Figure 10. Flammability and Vapor Pressure Diagram for JP-4 in Air at Various Temperatures and One Atmosphere Pressure

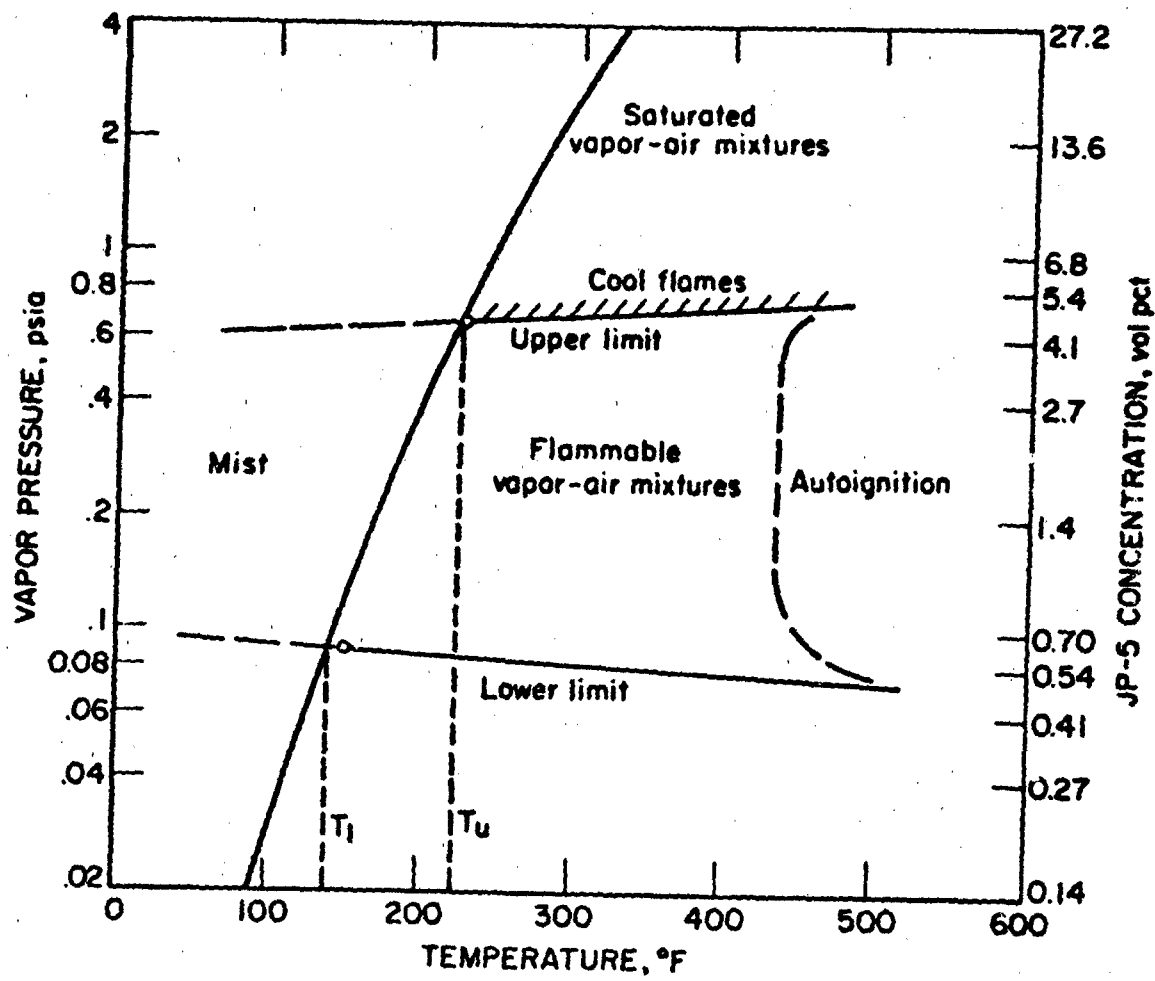

Figure 11. Flammability and Vapor Pressure Diagram for JP-5 in Air at Various Temperatures and One Atmosphere Pressure

- (2) Gaseous products - common species are CO, CO₂, H₂O, and N₂.
- (3) Flame temperature - about 1,200°C (2,192°F) for limit mixture.
- (4) Chemical luminescence - ultraviolet and infrared emissions.
- (5) Burning velocity - approximately 5 cm/sec (0.16 ft./sec.) for limit mixture and 50 cm/sec. (1.6 ft./sec.) for optimum mixture.
- (6) Pressure rise - about 8 to 1 pressure ratio for explosion of optimum mixture.

These flame properties are not applicable to "cool" flames which are normally associated with incomplete combustion and very low product gas temperatures. Such flames often occur with fuel-rich mixtures at or beyond the upper limit of flammability (see Figures 10 and 11).

Lower limits (L) and upper limits (U) of flammability for the aircraft fuels in air are given in Table 5; these limits refer to atmospheric pressure and 25°C (77°F) temperature or above the flash point of the fuel. As noted, the flammability range falls within 0.6% (L) and 4.8% (U) for the low volatility fuels and within 1.2% (L) and 8.2% (U) for the high volatility ones. Such limits can be estimated from the stoichiometric fuel concentrations (C_{st}) for complete combustion in air (Ref. 12):

$$L = 0.55 C_{st} \quad (10)$$

$$U = 4.8 (C_{st})^{1/2} \quad (11)$$

where all concentrations are in volume percent. C_{st} values for aircraft fuels are between 1 and 2-1/2% (Table 5). The stoichiometry for complete combustion of any hydrocarbon fuel can be determined as follows:

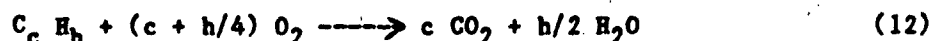

$$\% C_{st} \text{ (in oxygen)} = \frac{100}{1 + c + h/4} = \frac{\text{Moles Fuel} \times 100}{\text{Moles Fuel} + \text{Moles } O_2} \quad (13)$$

$$\% C_{st} \text{ (in air)} = \frac{100}{1 + 4.773 (c + h/4)} = \frac{\text{Moles Fuel} \times 100}{\text{Moles Fuel} + \text{Moles Air}} \quad (14)$$

where c and h are number of carbon and hydrogen atoms, respectively, and 4.773 is the reciprocal of oxygen molar fraction in air (0.2095). For combustion in air, 3.76 moles of N₂ (79/21) will be present as an inert for each mole of O₂ that is required (c + h/4) by equation 12. The C_{st} values for jet fuels approximate the values for high molecular weight paraffins or aromatic hydrocarbons. Complete combustion of fuels may be assumed for lower limit or fuel-lean mixture but not for upper limit or fuel-rich mixtures.

The following expression may be used to convert a limit concentration, e.g., a lower limit, in volume percent to a fuel-air (F/A) weight ratio:

$$(F/A) = \frac{M}{28.97} \left(\frac{L \text{ (vol. \%)}}{100 - L \text{ (vol. \%)}} \right) \quad (15)$$

where 28.97 and M are the molecular weights of air and fuel, respectively. For JP-4 fuel, the F/A weight ratio at its lower limit (1.3%) is 0.057 assuming a fuel molecular weight of 125 (liquid) and 0.035 for a molecular weight of 78 (vapor). The latter value is more realistic for the fuel vapor due to fractional distillation of low molecular weight components. Liquid and vapor molecular weights for JP-8 are 164 and 127, respectively, and comparable to the values of 169 and 135 for JP-4.

Flammability limits are often defined on a weight basis in terms of mg of fuel per liter of air ($g/l = oz./ft.^3$). For example,

$$L (mg/l) = [100 - L (vol.\%)] \frac{L (vol.\%) \cdot 22.414 (l)}{M (mg)} \quad (16)$$

where L is lower limit and M is molecular weight of the fuel. As a rule of thumb, most aircraft fuels will have lower limits of 45-55 mg/l and upper limits of 300-350 mg/l in air at normal temperature and pressure.

Limits of flammability are generally widened with an increase of ambient temperature. Figures 10 and 11 indicate the temperature effect for JP-4 and JP-5. In the absence of data, one may predict the temperature effect on the limits of hydrocarbon type fuels in air by the following equations (Ref. 12):

$$L_{T_2} = L_{T_1} [1 - 0.000401 (T_2 - 77^\circ)] \quad (17)$$

$$U_{T_2} = U_{T_1} [1 + 0.000401 (T_2 - 77^\circ)] \quad (18)$$

where T_2 is in $^\circ F$ and the limits are in volume percent. However, the upper limits of high molecular weight hydrocarbons and aircraft fuels can be noticeably greater than predicted by equation 18 because of their great ease of hot flame or cool flame ignition at relatively low elevated temperatures (i.e., at low AIT's). These expressions are most reliable for normal ignitions of homogeneous fuel vapor-air mixtures that behave similarly to those of paraffinic hydrocarbons.

With decreasing pressure of the atmosphere, the concentration limits (L or U) of flammability are not greatly affected if the ambient temperature is fixed. The data in Table 7 show that such limits for the aircraft fuels in air are reduced only slightly (if at all) with reduced pressures down to nearly 1/10 atmosphere, or pressure altitude of about 50,000 ft. (15 km). Any reduced flammability at low pressures is usually attributable to wall quenching effects and inadequacy of the ignition energy source.

**TABLE 7 EFFECT OF REDUCED PRESSURE ON FLAMMABILITY LIMITS AND
 MINIMUM OXYGEN REQUIREMENTS FOR GASOLINE AND JET FUELS
 IN AIR, AIR-CO₂, AND AIR-N₂ MIXTURES AT 25°C (77°F)¹**

Fuel	Pressure atm	Flammability Limits, vol. % In Air		Minimum Oxygen for a Flammable Mixture vol %	
		L	U	Air-CO ₂	Air-N ₂
Motor Gasoline ²	1	1.4	7.6	14.4	11.6
Av Gas 100/130	1	1.3	7.15	14.8	11.9
	0.53	1.25	6.75	14.1	11.2
	.27	1.3	6.85	14.1	11.6
	.13	1.4	7.6	14.8	11.9
Av Gas 115/145	1	1.2	7.1	14.6	11.9
	.53	1.25	6.9	14.6	11.6
	.27	1.25	7.0	14.8	11.6
	.13	1.5	7.85	14.5	12.0
Kerosene	1	0.7 ³	4.8 ³	14.0 ³	11.0 ³
JP-4	1	1.3	8.2	14.3(13.8) ³	11.5(10.9) ³
	.5	1.3	7.85	14.5	11.4
	.27	1.35	8.05	14.6	11.7
	.13	1.35	8.1	14.9	12.4

¹ References 13, 14, 15, and 16.
² Average for 73-100 octane mixtures
³ Data at 100°-150°C.

Corresponding temperature limits of flammability (T or T_u) of aircraft fuels decrease noticeably with increasing pressure altitude of the atmosphere. This is illustrated in Figure 12 (Ref. 17) for Jet A (or JP 8) and Jet B (or JP-4) fuel vapor-air mixtures that may form under equilibrium conditions. For both types of fuel, the flammability range narrows with increasing altitude or decreasing pressure until a pressure limit of flammability is reached at approximately 65,000 ft. altitude. This pressure effect will be less evident with strong ignition sources, such as an incendiary or high electrical energy source; therefore, the narrowed limits at low pressures are referred to as ignitability limits. Figure 12 also includes the altitude temperatures for a tropical, standard, and subarctic atmosphere. If these temperature profiles are encountered in flight, it is evident that the formation of flammable equilibrium vapor-air is limited to a tropical atmosphere for Jet A, and standard atmosphere for Jet B; also, flammable mixtures would be present over a much wider range of altitudes with the Jet B type fuel.

Under actual flight conditions, the flammability range can be widened by the formation of flammable mists or foams as a result of vibration and agitation of the fuel tank. This can also occur during a fuel loading operation. Such dynamic action extends the flammable range on the fuel-lean side since

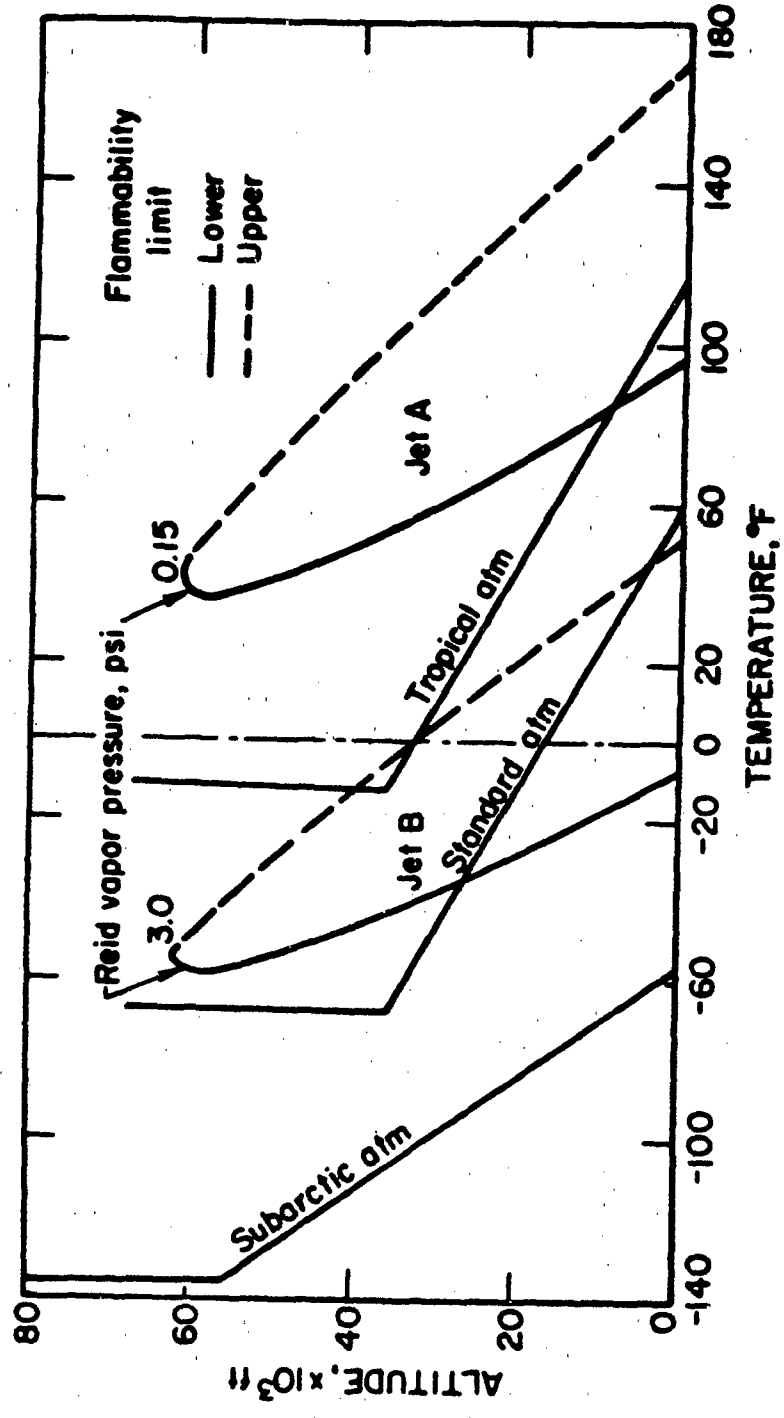

Figure 12. Pressure Altitude - Temperature Limits of Flammability for Jet A and Jet B Type Fuels in Air.

fuel mists can have flash points below the lower temperature limit (T) of flammability that is determined under static or equilibrium conditions; Figure 13 compares static and dynamic temperature limits (Ref. 9). In comparison, when a fuel degasses oxygen from any dissolved air, the fuel-rich limit (T_u) will tend to be increased somewhat.

Meager flammability limit data are available for the aircraft lubricants, hydraulic fluids, or missile fuels, all of which require high temperatures to form flammable vapor-air mixtures. The lower limit of the MIL-L-7808 fluid is approximately 48 mg/l (0.048 oz./ft.³) at 500°F; a value close to 50 mg/l is also expected for the MIL-H-5606 and MIL-H-83282 hydraulic fluids. Corresponding values for other fluids may be roughly estimated from the data available for neat organic compounds of similar chemical classes.

D. INERTING REQUIREMENTS

One of the safety measures used to guard against fuel vapor-air explosions is the addition of sufficient inert gas, such as CO₂ or N₂, to prevent the formation of flammable mixtures. If a fuel system is properly inerted, little or no flame propagation will occur beyond the ignition point. Complete flammability diagrams are required for this purpose, such as Figure 14 for a high volatility jet fuel (JP-4) and Figure 15 for aviation gasoline (115/145) with CO₂ and N₂ as the inert gases (Refs. 1, 15). Of particular interest is the nose of each curve, which defines the minimum CO₂ or N₂ to prevent flame propagation of all possible flammable mixtures. As noted, JP-4 requires at least 42% N₂ or 29% CO₂ to prevent any possibility of a flammable mixture. The effect of adding air, inert, or fuel to any composition can be ascertained by extrapolating the composition point towards 100% air, inert, or fuel, respectively. Note that the composition points on the ordinate (0% inert) correspond to the lower (L) and upper (U) limits of flammability in air alone.

The minimum oxygen concentration below which flammable mixtures will not form is widely used in defining inerting requirements. This value corresponds to the oxygen concentration of the composition point(s) just outside the nose of the flammability diagram. Such data are included in Table 7 for gasolines and jet fuels at various pressures. As with neat hydrocarbons, the minimum oxygen values are largely between 14 and 15% for air-CO₂ mixtures and between 11 and 12% for air-N₂ mixtures. The effect of temperature on the minimum oxygen values will tend to approximate that predicted for lower limits of flammability:

$$(\text{Min. } O_2)_{T_2} = (\text{Min. } O_2)_{T_1} [1 - 0.000401 (T_2 - 77^\circ)] \quad (19)$$

where T₂ is in °F and Min. O₂ is in volume percent. With a knowledge of the minimum O₂ value and flammability limits (L, U) in air, one may construct a crude approximation of a complete flammability diagram for the given system, assuming the flammability envelope will be triangular shaped. Any composition point in such diagrams is defined by the following expression:

$$\% \text{ Air} = \frac{\% O_2}{0.21} = \frac{\% N_2}{0.79} = 100 - \% \text{ Fuel} - \% \text{ Added Inert} \quad (20)$$

Engine exhaust gases and volatile halogenated hydrocarbons are also used as inerting agents. Figure 16 (Ref. 16) compares the effectiveness of such

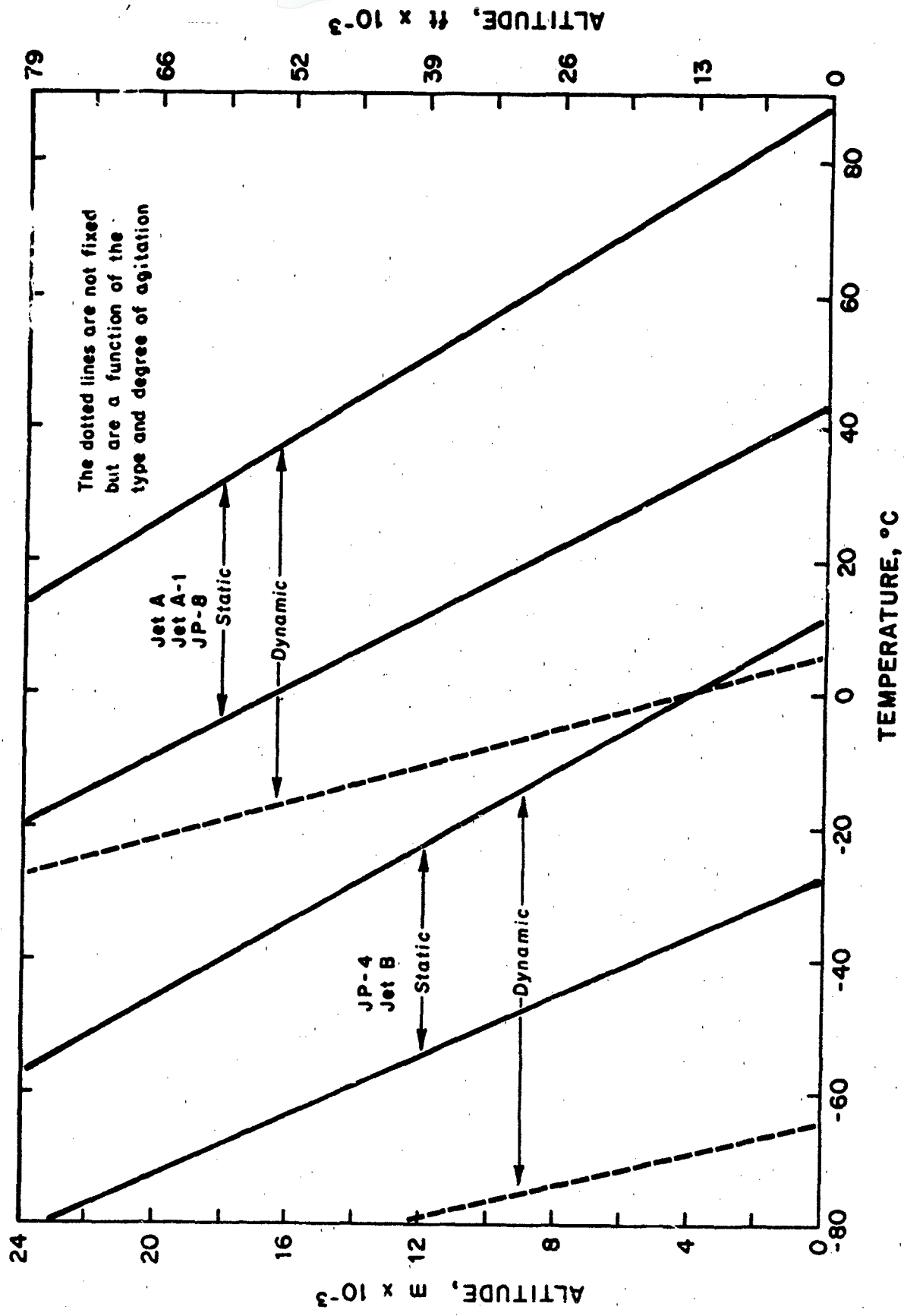

Figure 13. Effect of Tank Dynamics on the Relative Flammability Limits of JP-4, Jet B, Jet A, Jet A-1, and JP-8 Fuels

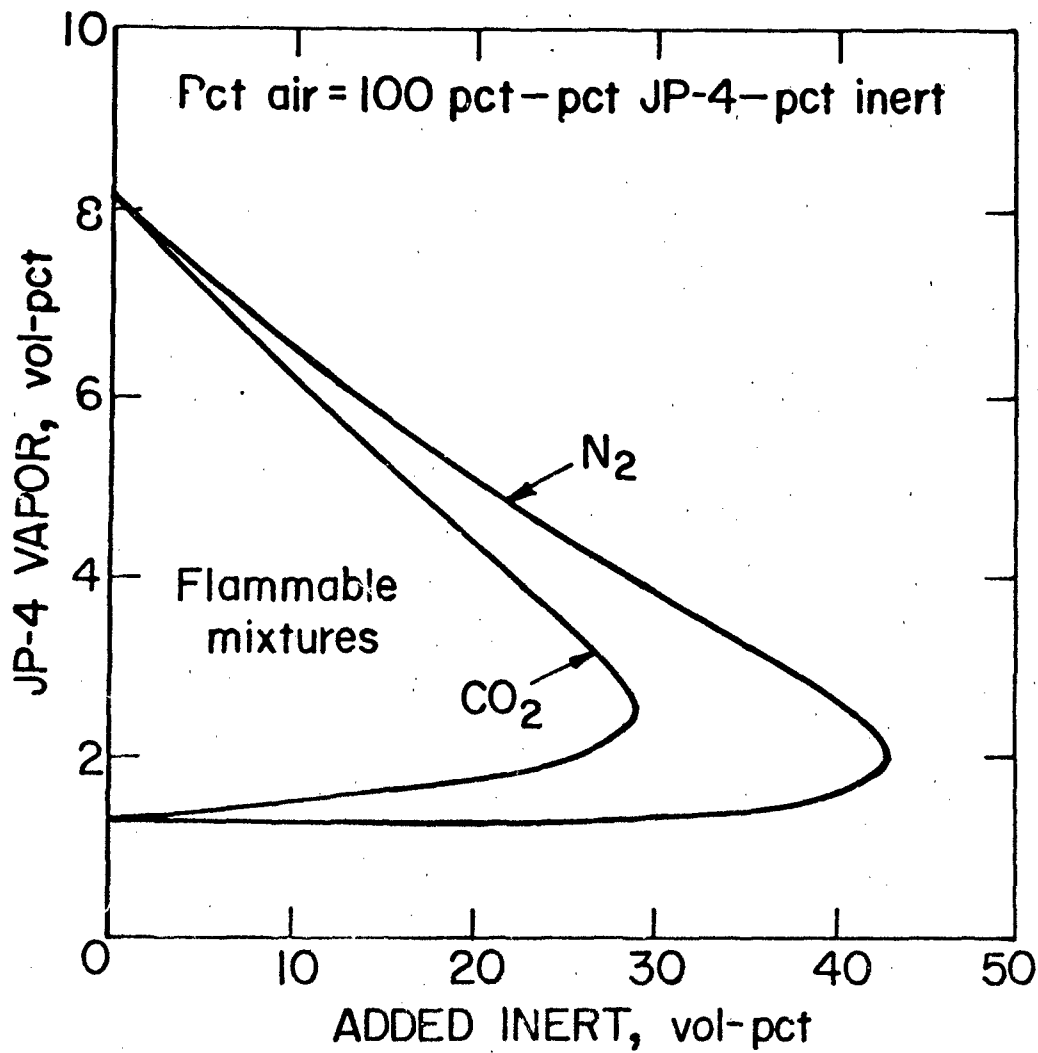

Figure 14. Concentration Limit of Flammability of JP-4 Vapor - Air - Inert Gas (CO₂ or N₂) Mixtures at 25°C (77°F) and One Atmosphere

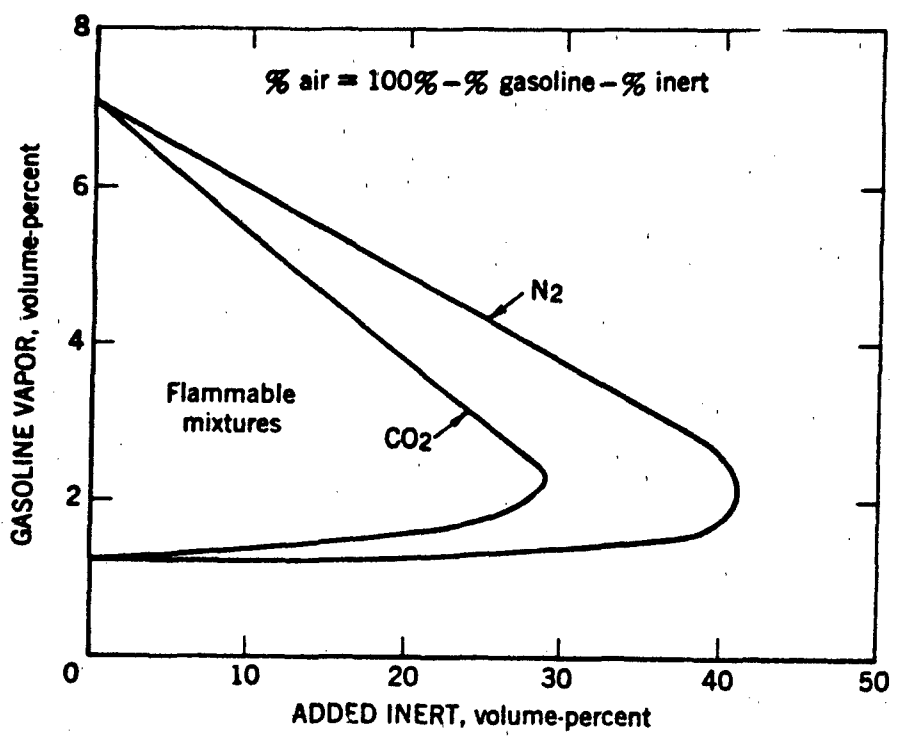

Figure 15. Concentration Limits of Flammability of Aviation Gasoline (115/145) Vapor - Air - Inert Gas (CO₂ or N₂) Mixtures at 25°C (77°F) and One Atmosphere

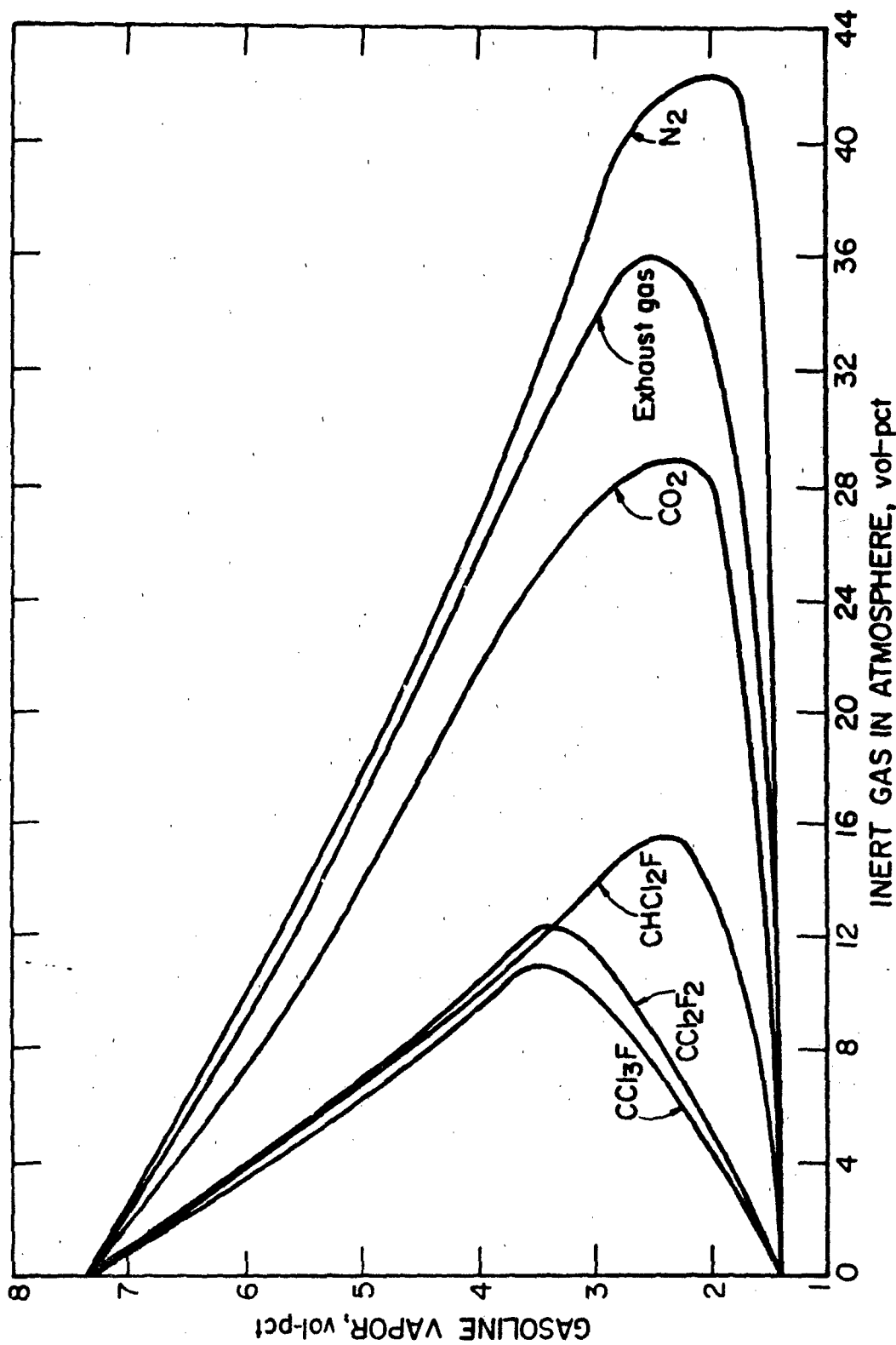

Figure 16. Effectiveness of Various Inerting Agents on the Flammability of Gasoline Vapor - Air Mixtures at 25°C (77°F) and One Atmosphere

inerting agents with CO_2 and N_2 in ignitions with gasoline vapor-air mixtures (composite values for motor gasolines of 73, 92, and 100-octane rating). The minimum O_2 values derived from these data are between 11.5 and 14.4% for the N_2 , CO_2 , and exhaust gas (85% N_2 + 15% CO_2) inerts. In comparison, the halogenated methanes are much more effective inerting agents and gave minimum O_2 values of at least 17%. Two of the most effective halogenated inerting agents are Halon 1301 ($\text{CF}_3 \text{ Br}$) and Halon 1211 ($\text{CF}_2 \text{ Cl Br}$); only about 5% of these agents is required to inert hydrocarbon type fuels (Ref. 1). In terms of inerting agent concentrations, Halons 1301 and 1211 are roughly 5 times more effective than CO_2 , and CO_2 is roughly 1-1/2 times more effective than N_2 .

Since most of the above-cited data were obtained with a localized spark ignition source, the inerting requirements can be noticeably greater when much stronger ignition sources are encountered. The effectiveness of chemical flame inhibitors, such as the Halons, can be particularly affected because these materials are not inert and can react as fuels when they are preheated to excessive temperatures.

E. IGNITION ENERGIES

Most combustible-oxidant systems are not capable of self-ignition at ambient temperature and, therefore, they require an external temperature or energy source to produce sufficient heating for ignition (flaming combustion). It is useful to categorize the ignition sources in terms of their temporal and spatial characteristics (Figure 17). At one extreme (electrical sparks), the source is infinitesimally small, both temperature and heating rate are very high, but heating duration is very short; therefore, energy of the source is most critical for ignition. At the other extreme (heated vessels), the source is large, both temperature and heating rate are low, but heating duration is relatively long; here, temperature is the most critical factor. Both temperature and heating rate can be important for intermediate cases.

Minimum ignition energies (MIE) of flammable fuel vapor-oxidant mixtures are normally determined with an electrical spark discharge because of the great efficiency of this localized heat source in producing ignitions. These values are obtained with the most favorable fuel-oxidant concentration and optimum conditions of electrode material, geometry, and gap separation. Figure 18 (Ref. 18) shows data for several paraffinic hydrocarbons in an ambient air atmosphere. As in this figure, the ignition energy for most fuels is minimum on the rich side of stoichiometric and tends to be infinitely large at fuel-air ratios approximating the lower and upper limits of flammability. Most important is that the MIE is approximately 0.25 mj for the vapor-air mixtures of many hydrocarbon combustibles. Aircraft hydrocarbon fuels can be assumed to have a comparable MIE value. Combustibles with much lower MIE values include ethylene (0.07 mj), acetylene (0.017 mj), and hydrogen (0.017 mj); those with much higher values include ammonia (>1,000 mj) and most halogenated hydrocarbons.

Electrical discharges may be classified as high voltage or electrostatic-spark type and low-voltage or break-spark type (arc). The electrostatic sparks are formed when the electrical charge of a conductor or nonconductor is sufficient to bridge ("jump") a gap to another conductor or nonconductor. The energy of discharge is:

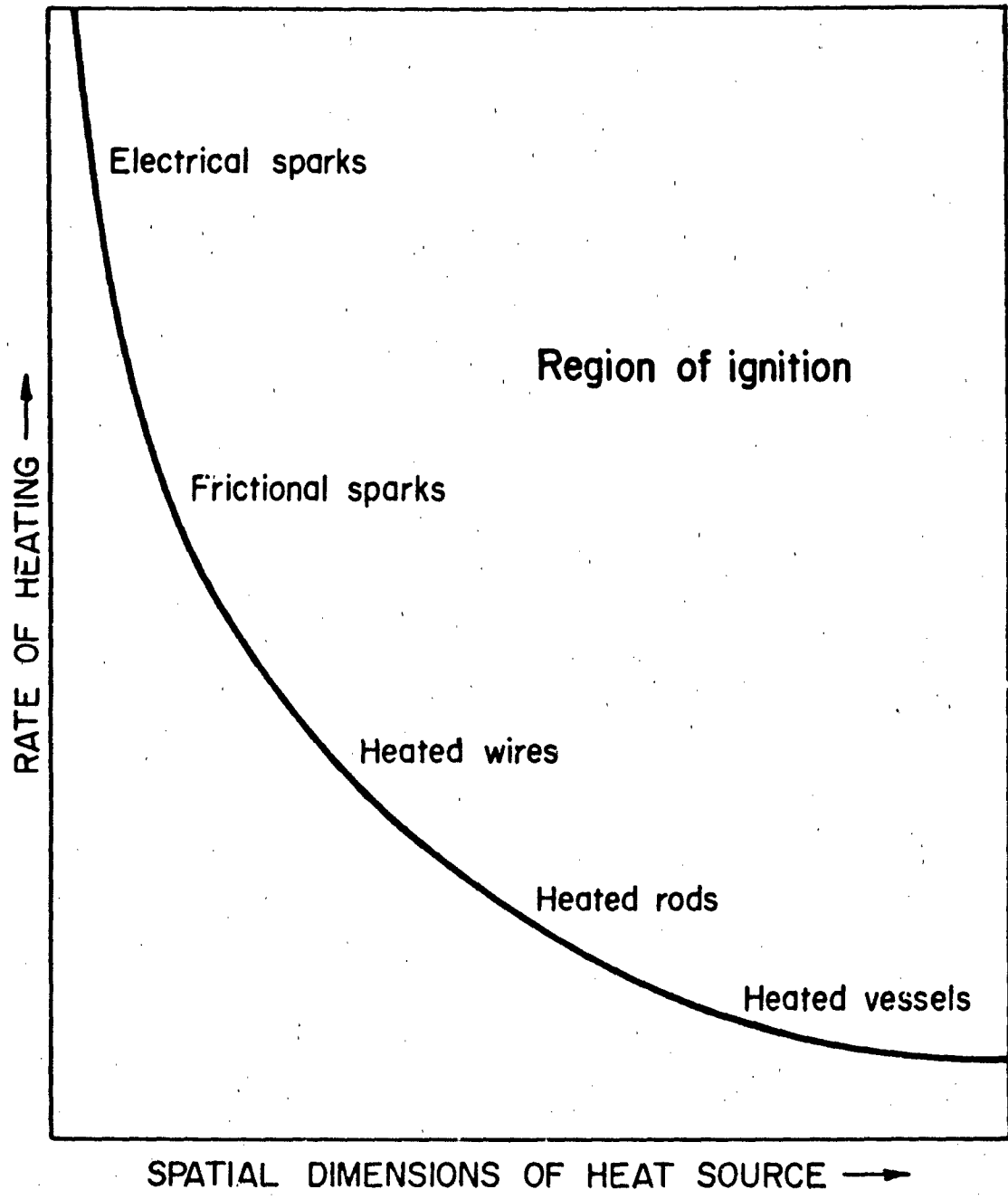

Figure 17. Temporal and Spatial Characterization of Various Ignition Sources

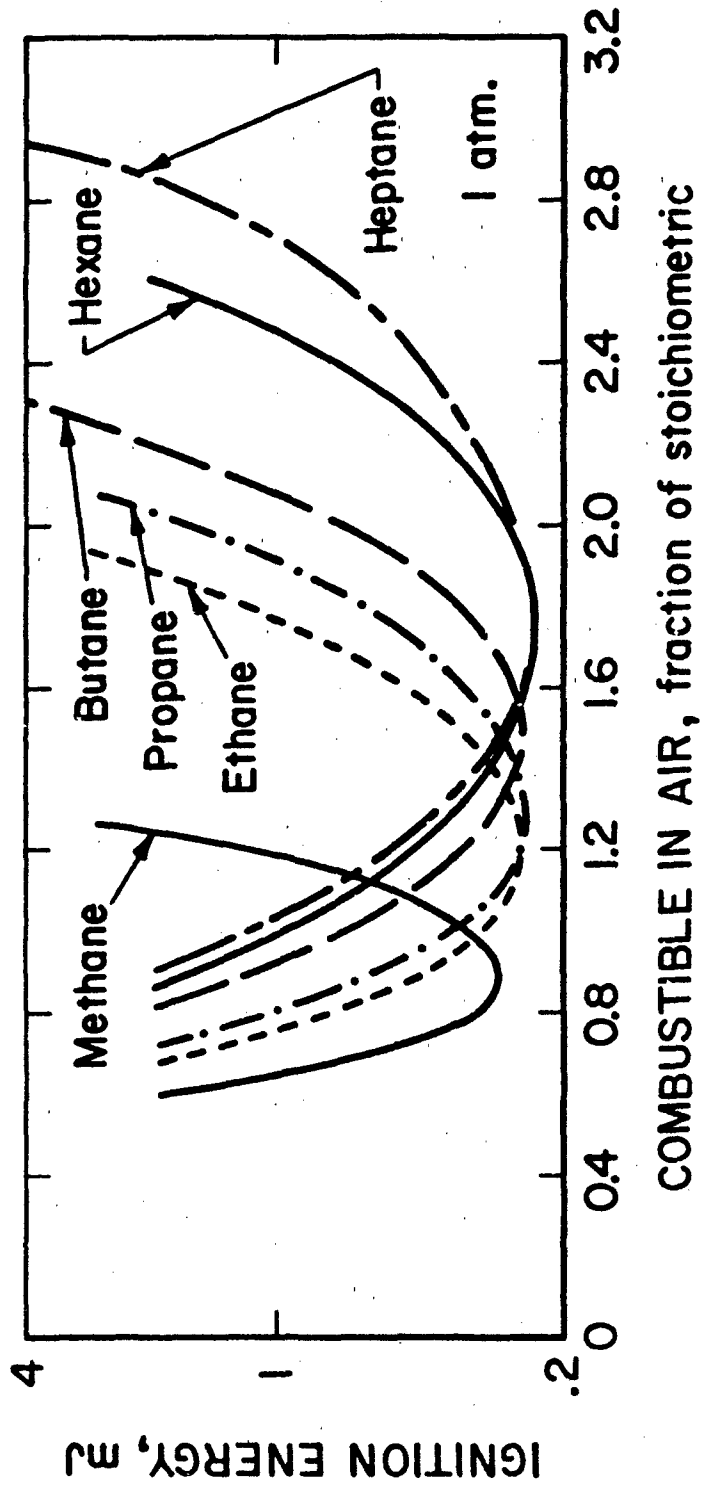

Figure 18. Spark Ignition Energy Versus Combustible Vapor Concentration for Various Hydrocarbons in Air at 25°C (77°F) and One Atmosphere

$$E = 1/2 CV^2 \quad (21)$$

where E is the stored energy (joules), C is capacitance of the charged material (farads), and V is the potential difference (volts); capacitance is related to the electrical charge (Q, coulombs) by $C = Q/V$. Typical capacitances are (Ref. 19):

Man	-	100 to 300 x 10 ⁻¹² farads
Automobile	-	500 x 10 ⁻¹² farads
Tank Truck	-	1,000 x 10 ⁻¹² farads

Thus, a human charged to 10,000 volts would conceivably produce a static discharge of 1.5×10^{-2} joules (15 mj) by equation 21.

The generation of static electricity can occur from the frictional action of two electrically unlike materials, i.e., triboelectrification. This frequently occurs in the pumping of liquid fuels, pneumatic transport of solids, and processes involving plastic containers. The ability of a nonconductor (or conductor) to accumulate a static charge will depend upon its resistivity (Resistance x Area/Length), as well as that of the surrounding medium. Liquids having resistivities greater than 10¹⁰ ohm-centimeter, which includes most petroleum products, are generally capable of accumulating a charge (Ref. 6). A charge accumulated by a good conductor can be dissipated by metal-to-metal bonding and grounding. The Air Force specifies the following resistance requirements for bonding or grounding:

- Electrical Hazards - Resistances < 1 ohm acceptable
- Electrostatic Hazards - Resistances < 10⁶ ohms acceptable

For poor conductors, the charge accumulation may be minimized by such measures as increasing humidity, reducing flow conditions, and use of anti-static additives. During fuel loading operations, the static ignition hazard will necessarily depend upon both loading rate and volatility of the fuel.

Fuel conductivity is measured in conductivity units (CU); 1 CU = 1 Picosiemens/Meter = 10⁻¹⁴ ohm⁻¹ cm⁻¹.

Therefore, a 200 CU fuel will have a resistivity of 5 x 10¹¹ ohm-cm. Since charge accumulation is the difference between charge generation and charge relaxation (bleed off), the higher CU fuel will tend to bleed off the charge faster and thus have a reduced electrostatic hazard. Some static sparks due to fuel movement have sufficient energy to ignite fuel vapors. Of course, to have a reaction, the fuel must be within the flammable range.

The low voltage break sparks (or arcs) are formed when current carrying conductors are abruptly separated to result in a collapsing electrical field. Typical examples are the arcs from opening switches, motor brushes, etc. The energy discharge is:

$$E = 1/2 LI^2 \quad (22)$$

where L is the circuit inductance (henries) and I is the current (amperes). The minimum energies with the inductive circuit are usually 2-10 times the MIE values with the capacitive discharge. However, the differences become less noticeable when the break sparks are produced with very fine wires and rapid separations, such that heat losses to the conductor surfaces are minimized.

In a flight environment, the minimum ignition energy will increase with increasing altitude or decreasing pressure. The variation of MIE with pressure may be expressed as:

$$MIE = (MIE)_0 (P/P_0)^{-m} \quad (23)$$

where subscript 0 refers to 1 atmosphere and m is approximately 2 for hydrocarbon type fuels (Ref. 19). With increasing temperature, the MIE's decrease roughly by a factor of 2 for a 150°F temperature change. They are also sensitive to oxygen concentration, decreasing by an order of magnitude or more with increased oxygen from 21% (air) to 100%.

Figure 19 (Ref. 1) illustrates the effects of pressure and oxygen concentration on the minimum ignition energies of propane-oxygen nitrogen mixtures. Most important in applying these data is the fact that the MIE's of ordinary combustibles are small compared to the electrical energies (order of joules) that could result from most accidental sparks or arcs in an aircraft. The ignition energies will tend to be infinitely great when the pressure or oxygen is reduced to near-limit values for flame propagation.

Ignition energy requirements are greater for heterogeneous fuel sprays than for homogeneous vapor-air mixtures since a fraction of the energy is used up in vaporizing the fuel droplets. With increasing temperature, the ratio of vapor to liquid increases and, therefore, the ignition energy decreases. Figure 20 (Ref. 1) shows such data for the sprays (10 μ) of three jet fuels. The variation of ignition energy (E , mj) with fuel temperature (T , °F) is given by:

$$JP-4 \quad E = 23.2 e^{-.042T} \quad (24)$$

$$JP-5 \quad E = 139 e^{-.034T} \quad (25)$$

$$JP-8 \quad E = 111 e^{-.037T} \quad (26)$$

With any sprays or mists, if the temperature is sufficiently elevated or if the fuel droplet size is less than 10 microns, the ignition energy will approximate the MIE value.

F. IGNITION QUENCHING DISTANCES

Minimum ignition quenching distance corresponds to the spark gap length required to obtain the minimum ignition energy. Such data are useful in designing flame arresting devices. The correlation between ignition energy and quenching distance is shown in Figure 21 (Ref. 19); data are summarized for a wide variety of combustibles in air and oxygen at pressures between 0.1 and 2 atm. Excluding high energy fuels such as hydrogen and acetylenic hydrocarbons, the minimum ignition quenching distance for most hydrocarbon fuel

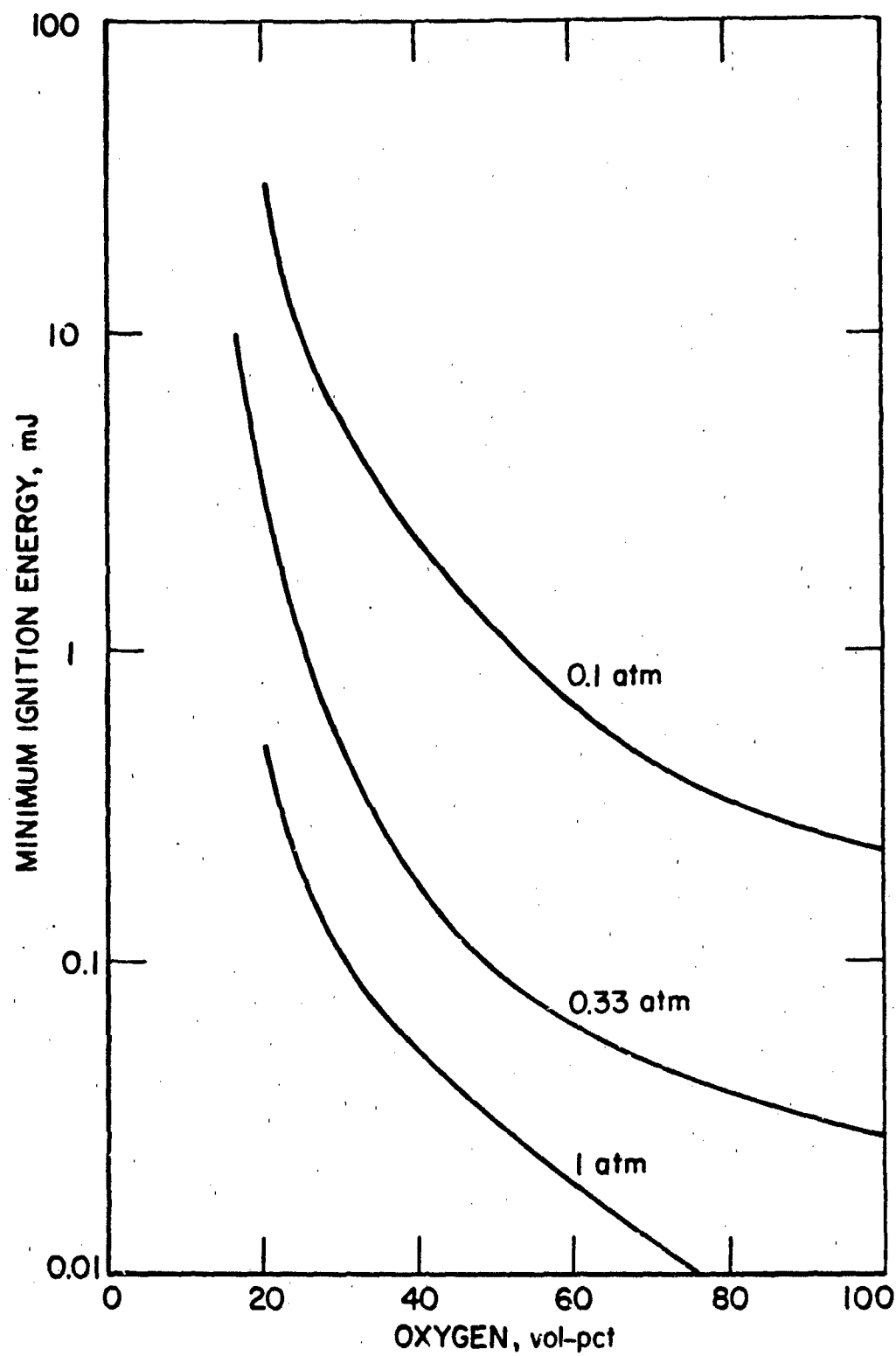

Figure 19. Minimum Ignition Energy of Propane - Oxygen - Nitrogen Mixtures as a Function of Oxygen Concentration and Mixture Pressure

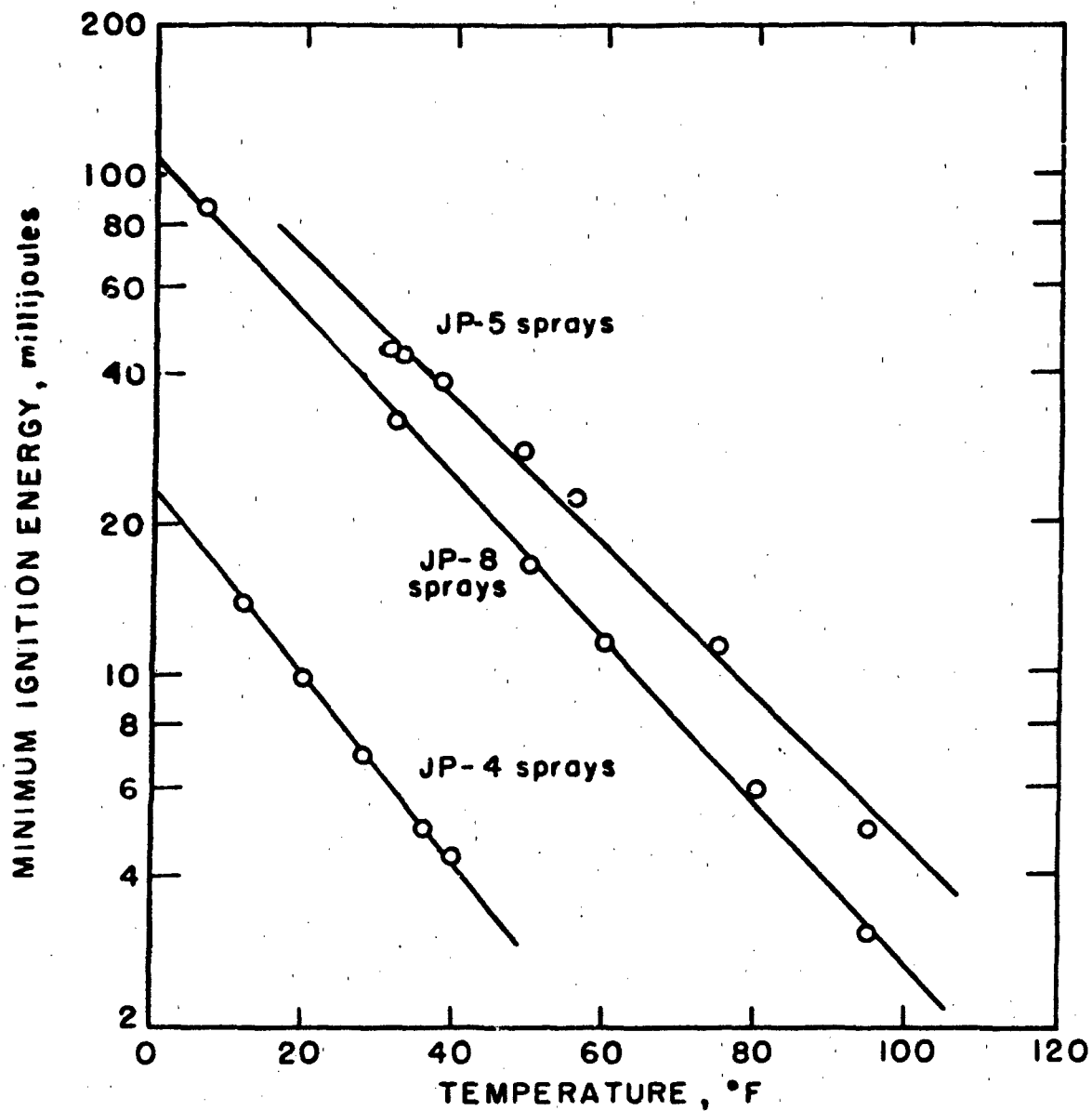

Figure 20. Minimum Spark Ignition Energies of the Sprays of Three Jet Fuels at Various Temperatures

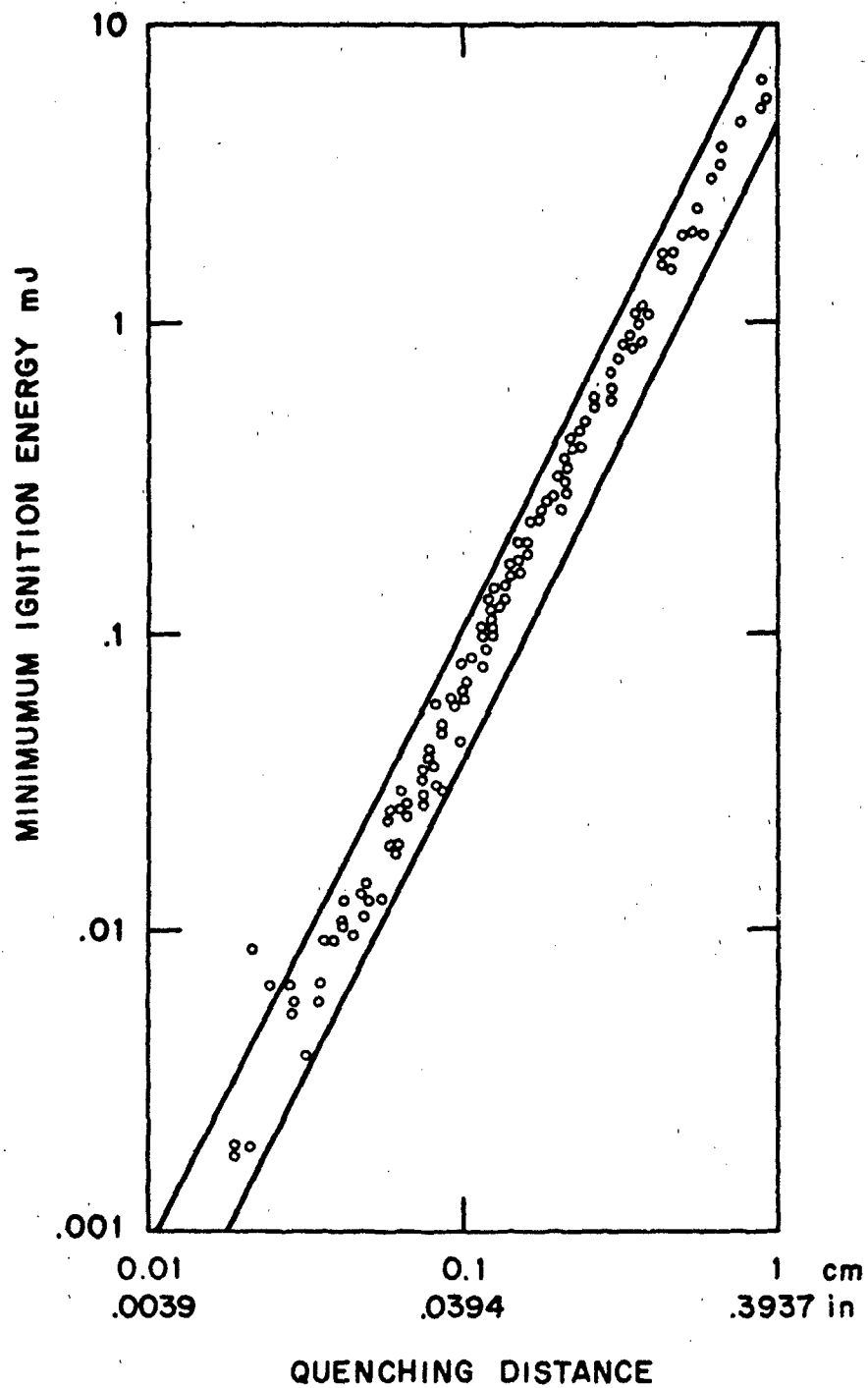

Figure 21. Correlation of Minimum Ignition Energy and Quenching Distance for Various Combustibles in Oxidant Atmospheres of 21 to 100% Oxygen and Pressures of 0.1 to 2 Atmospheres

vapor-air mixtures is between 0.125 cm (0.05 in) and 0.25 cm (0.1 in) at 25°C and 1 atmosphere. These data refer to quenching by flat plates. In comparison, quenching diameters in tubes are about 1-1/2 times greater than the flat plate values.

The above ignition quenching distances are associated with low flame velocities and, therefore, allowance must be made for high velocity flames that can be encountered. The critical approach velocity of a flame for quenching by wire gauze, ribbon, or similar flame arrestors may be predicted by the following expression (Ref. 20):

$$v = 0.5 a y/d^2 \quad (27)$$

where v is flame velocity (ft./sec.), y is arrestor thickness (in), d is diameter of aperture (in), and a is the proportion of arrestor surface free area not blocked by the arrestor material. An effective flame arrestor must not only quench the flame but also cool the hot product gases to prevent possible ignitions by hot gases discharging from the arrestor. Flame arrestors are not effective against detonations.

In the case of explosion-proof enclosures, both high flame velocities and high pressures can be involved. Maximum experimental safe gaps are relied upon for these severe applications, which can include conditions of large flame run-up distances and pressure piling. Maximum experimental safe gaps of hydrocarbon type fuels in air tend to be about 1/2 their corresponding values at their minimum ignition energy. Ignition and quenching requirements for aircraft jet fuels should not differ greatly from the following approximate values reported for n-heptane (Ref. 21):

Minimum Igniting Current	~ 0.18 amp
Maximum Experimental Safe Gap	~ 0.036 in

The minimum igniting current, which varies with the electrical circuit, refers to break-type sparks and is especially of interest in evaluating intrinsically safe electrical equipment, which is usually of low voltage. National Electric Code specifications for explosion-proof and intrinsically safe equipment are further discussed under the section on "Explosion Damage Analysis."

G. IGNITION TEMPERATURES

Ignition is normally considered a vapor phase combustion reaction with the evolution of heat and emission of light of varied intensity. Typical ignitions involve the rapid oxidation of a combustible in air, oxygen, or other oxidants; they can also occur without an oxidant when the combustible (e.g., acetylenic hydrocarbons and hydrazines) is capable of highly exothermic decomposition. For ignition to occur, the combustible-oxidant system must be initially heated to some critical temperature above which the reaction is accelerated to produce a luminous or nonluminous flame. This critical temperature is the ignition temperature and may be achieved by self-reaction at ambient temperature (spontaneous combustion) or by exposure to an added heat source. The earlier discussion of the temporal and spatial characteristics of ignition heat sources

(Figure 17) is also pertinent here in classifying ignition temperatures. All ignition temperatures are apparatus dependent.

Minimum autoignition temperature (AIT) defines the lowest temperature at which the vapors of a combustible in air or other oxidant will ignite in a uniformly heated container. The optimum conditions for these ignition temperatures are fuel concentrations on the rich side of stoichiometric, vessel diameters of at least 2 inches for approximate AIT's, and heating durations (ignition delays) of up to about 5 minutes. The AIT's may also vary with the container material, particularly if iron rust or other catalytic contaminants are present, and with the criterion of ignition that is used (e.g., pressure rise vs. appearance of flame). AIT values for the aircraft fuels, lubricants or hydraulic fluids, and missile fuels in atmospheric air are summarized in Tables 5 and 6; glass vessels and visible flame criterion were used to obtain these data.

The minimum AIT's of most aircraft fuels in air (1 atm) are roughly about 450°F (232°C); exceptions include the Av-Gas fuels and the RJ-4 missile fuel which have substantially higher AIT's. The MIL-H-5606 mineral oil hydraulic fluid also has approximately the same AIT hazard as the jet fuels. Other hydraulic fluids and engine oils or lubricants have AIT's between 650° and 1200°F, depending upon their chemical class. Phosphate esters, aromatic ethers, and halogenated fluids are typical of the most fire resistant fluids.

In all such ignitions, a reaction time is required before the chemical heat release at the given temperature is sufficient to produce flaming combustion. This time period is grossly referred to as the ignition delay (or fuel contact time) and tends to be infinitely large as the minimum AIT is approached. The semi-log plots in Figure 22 (Ref. 10) show the temperature dependence of ignition delay (τ) for heated vessel ignitions of 4 aircraft fuels in air at 1/2 and 1 atm pressure; JP-6 and JP-150 are research jet fuels.

Ignition temperatures generally increase with decreasing pressure and oxygen concentration of the system, although these effects will vary with the chemical class of combustible. Available AIT data on these effects are summarized in Table 8 for aircraft fuels and hydraulic fluids or lubricants in air and oxygen atmospheres (Refs. 10, 14, 22). The effect of reduced pressure on AIT's in air is greatest for aircraft fuels or fluids having the lowest AIT's at atmospheric pressure. In theory the variation of AIT with pressure and oxygen concentration should depend primarily upon the oxygen partial pressure of the system. The reported data for the JP-6 fuel are consistent in this respect according to Figure 23 (Ref. 10).

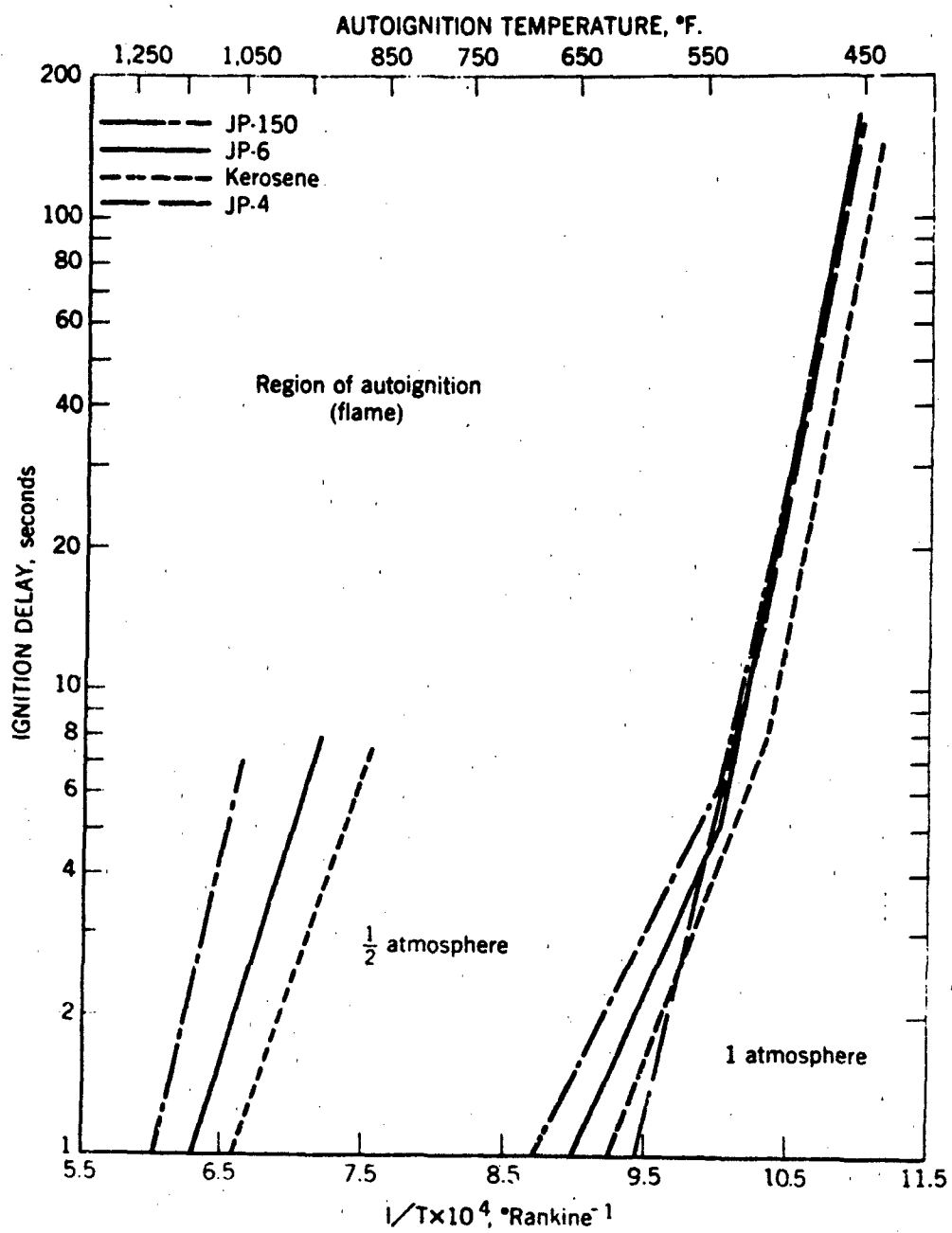

Figure 22. Variation of Ignition Delay with Reciprocal Temperature in Autoignition of Four Aircraft Fuels in Stagnant Air at 1/2 and One Atmosphere.

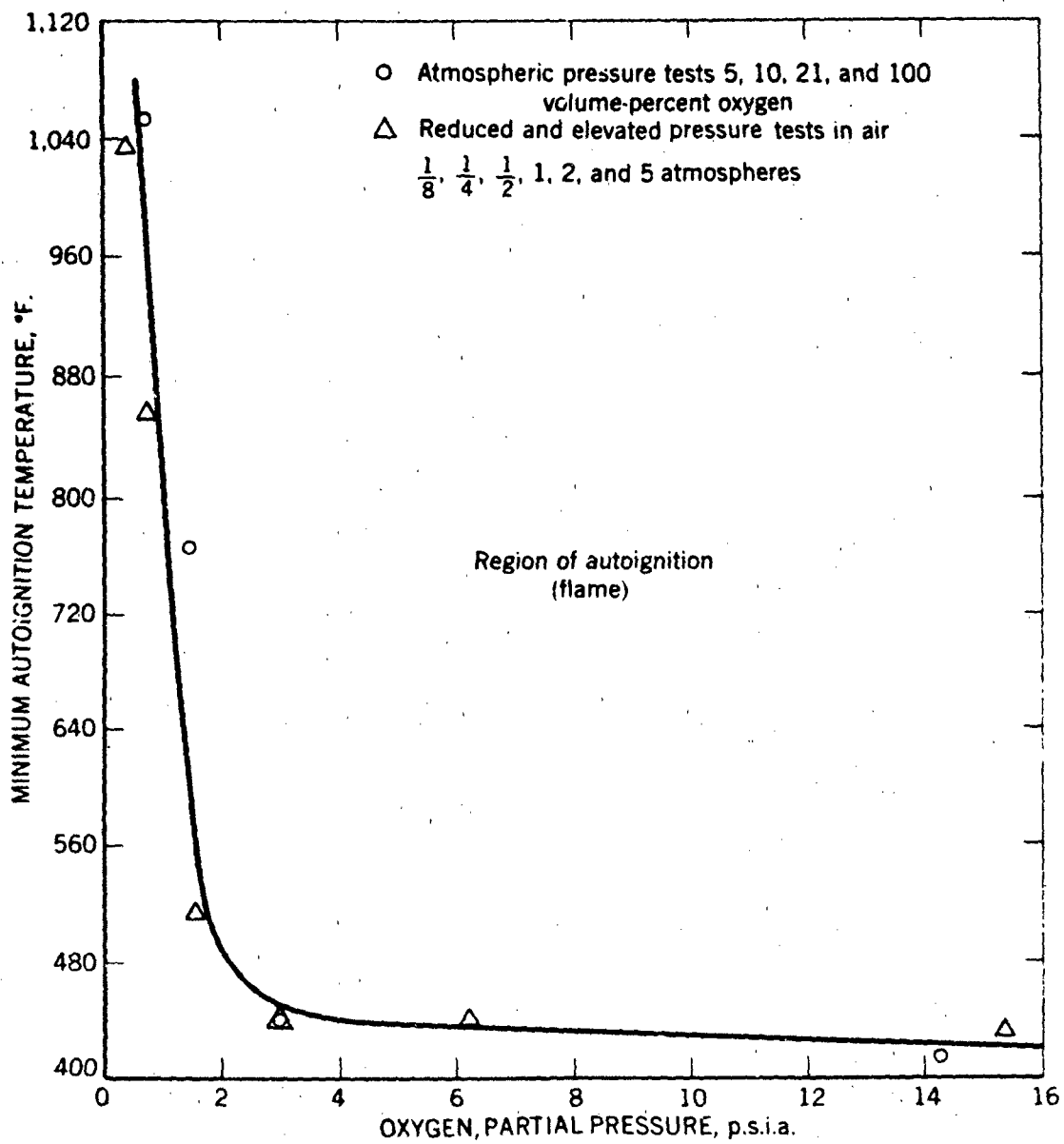

Figure 23. Effect of Oxygen Partial Pressure on Minimum Autoignition Temperature of JP-6 Fuel Vapor - Oxygen - Nitrogen Mixtures at Various Total Pressures

TABLE 8 EFFECTS OF PRESSURE AND OXYGEN CONCENTRATION ON THE MINIMUM AIT'S OF AIRCRAFT FUELS, HYDRAULIC FLUIDS, AND LUBRICANTS*

	Minimum AIT, °F			
	In Air		In Oxygen	
	1/4 atm	1/2 atm	1 atm	1 atm
Kerosene	1100	865	445	420
Av Gas 100/130	-	1030	825	600
Av Gas 115/145	-	1060	880	-
JP-4	1060	830	445	-
JP-6	1135	925	445	43
	Hydraulic Fluids and Lubricants			
MIL-R-5606	1033	820	437	428
MLO-53-446	828	795	785	765
MLO-54-540	950	838	703	445
MLO-8200	972	842	715	470
MIL-L-7808	-	-	735	518

* References 10, 14, and 22.

In compressors and other high pressure equipment, the AIT's of aircraft fluids are of interest at high pressures. In Figure 24 (Ref. 12), the AIT's of phosphate ester, mineral oil, and water-glycol lubricants in air are decreased by a factor of nearly 1/2 when pressure is increased to 100 atm. The effect of pressure is small above 100 atm; this was confirmed in subsequent determinations with such fluids (Figure 25), including the MIL-L-7808 fluid, at pressures to 1000 atm (Ref. 10).

Compression ignition of combustible fluid vapors can occur when they are rapidly pressurized and heated by isentropic compression or shock compression (nonisentropic). This may occur in fuel-contaminated air compressors, oxygen cylinder regulators, or other equipment where fuel vapors and an oxidant are suddenly compressed to high pressures. The theoretical gas temperatures (T_2) which can result from adiabatic and shock compression of air initially at 32°F and 1 atm are compared in Table 9 for various compression ratios (P_2/P_1); values at other pressure ratios may be calculated by equation 8. Thus, together with the AIT data in Figure 24, one may estimate the compression ignition temperature hazard for the particular fluids. For example, the adiabatic compression temperature of 970°F at a P_2/P_1 ratio of 50 would appear adequate for ignition of most fuels or fluids. However, the time scale of heating or fuel contact time for AIT determinations (seconds or minutes) is much greater than for either adiabatic heating (e.g., milliseconds) or shock heating (e.g., microseconds). Because of these and other complicating factors, the compression temperatures required for autoignition will be noticeably higher than the AIT of the particular fluid.

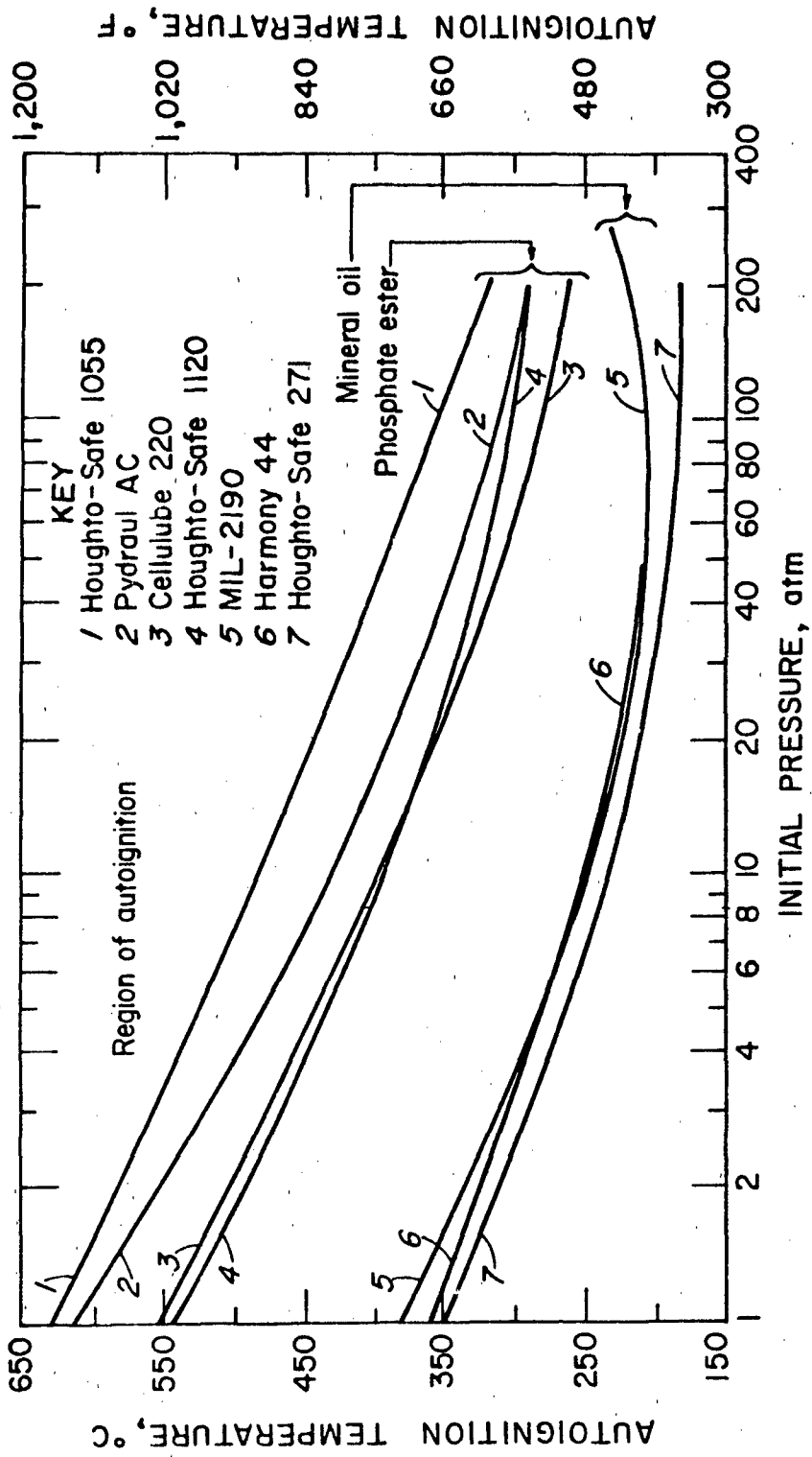

Figure 24. Minimum Autoignition Temperatures of Phosphate Ester, Mineral Oil, and Water-Glycol Lubricants in Air at Various Initial Pressures

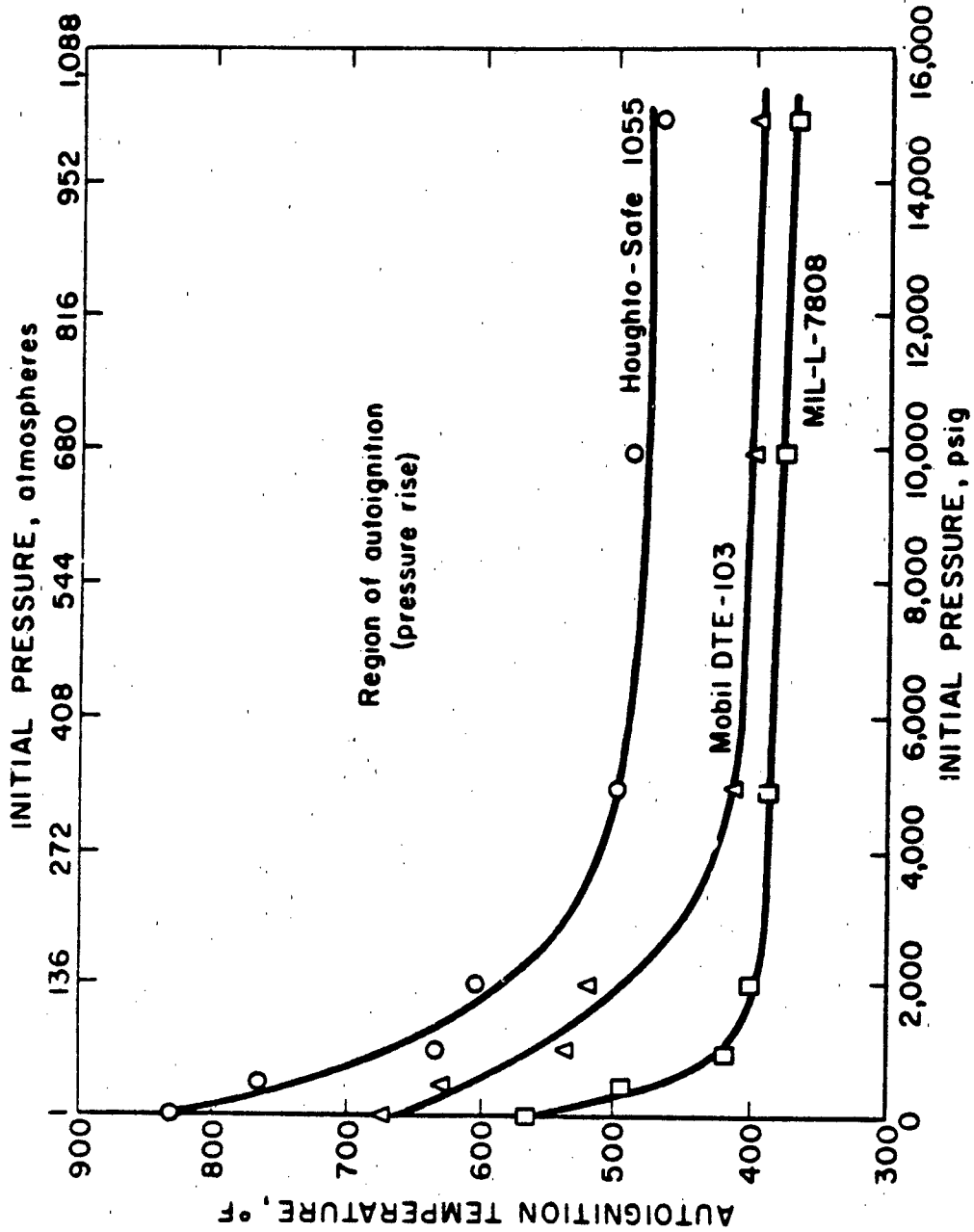

Figure 25. Minimum Autoignition Temperatures of Houghto-Safe-1055, Mobil DTE-103, and MIL-L-7808 Lubricants in Air at Various Initial Pressures.

**TABLE 9 SHOCK WAVE AND ADIABATIC
 COMPRESSION TEMPERATURES OF AIR**
 $P_1 = 14.7$ psia; $T_1 = 32^{\circ}\text{F}$

Compression Ratio P_2/P_1	Compression Temperature $^{\circ}\text{F}$	
	Shock Wave	Adiabatic Compression
2	144	134
5	406	306
10	810	467
50	3,610	970
100	6,490	1,250
1,000	33,940	2,615

Hot manifold ignitions involve nonuniform surface heating and may occur when a combustible fluid impinges on a heated surface, such as an aircraft engine housing or cowling. Here, ignition temperatures will vary with the size and configuration of the heated surface, velocity and temperature of the fluid spray or liquid, and the ventilation conditions. Data in Table 10 (Ref. 24) show that such ignition temperatures for the aircraft fuels and fluids are greater when the combustibles are injected as sprays than as liquid streams. They are also usually greater than corresponding AIT's that are obtained in uniformly heated vessels. Regardless of volatility differences, the results for the jet fuels did not differ greatly. Data from reference 10, which were obtained under somewhat similar conditions, are also included in Table 10 to indicate the extent such ignition temperatures may vary. The latter work shows that hot manifold type ignition temperatures decrease about 200°F when the diameter of the heated metal target is increased from 1 in. to 4 in. Lower ignition temperatures are possible when the fuel vapors or mists can be trapped or confined near the heated surface, thereby increasing the fuel contact time as in heated vessel autoignitions.

Wire ignition temperatures are associated with small diameter heat sources, such as electrical or frictional heated elements. They are much higher than heated vessel AIT's, depending upon the size or area of the heat sources. Figure 26 (Ref. 1) shows the variation of wire, rod, and vessel ignition temperatures as a function of the surface area of the heat source for ignitions of combustible vapor mixtures in near-stagnant air. These data gave the following expressions:

$$\text{JP-6} \quad T = 1430 - 201 \ln A ; A < 11 \quad (28)$$

$$\text{MIL-L-7808} \quad T = 1175 - 115 \ln A ; A < 29 \quad (29)$$

where T is ignition temperature ($^{\circ}\text{F}$) and A is surface area (in^2). Corresponding equations in terms of the heat source radius (r) are:

$$\text{JP-6} \quad \ln r = 21000/T - 13.50 ; r < 0.3 \quad (30)$$

$$\text{MIL-L-7808} \quad \ln r = 25800/T - 18.53 ; r < 0.5 \quad (31)$$

where T is in $^{\circ}\text{R}$ and r is in inches; nichrome wire or rods were used. Note that only the high AIT fluid (MIL-L-7808) gives a consistent correlation over

TABLE 10 COMPARISON OF HEATED VESSEL AIT'S AND HOT MANIFOLD IGNITION TEMPERATURES OF AIRCRAFT FUELS AND FLUIDS IN AIR AT 1 ATM¹

Fuel	Chemical Class	Minimum Ignition Temperature; °F		
		AIT	Hot Manifold	
			Liquid Stream	Spray
Hydraulic Fluids				
MIL-H-5606	Mineral oil	461	730(960) ³	1330
MIL-H-83282	Synthetic	656	630(1080) ³	1250
Skydrol 500B	Phosphate ester	950	1440	1500
Chevron M2V	Silicate ester	698	700	-
Lubricating Oils				
MIL-L-7808	Acid diester	735	1300(1010) ³	1500
MIL-L-23699	Polyol ester	775	1100	1500
Jet Fuels and Missile Fuels				
JP-4	Hydrocarbon	446 ²	1300(920) ³	
JP-5	Hydrocarbon	437 ²	1300	
JP-7	Hydrocarbon	465 ²	1300	
JP-8	Hydrocarbon	437 ²	1200(900) ³	
JP-9		465	1300	
RJ-5		445	1100	

¹ Data from reference 24
² Data from Table 5
³ Data from reference 10

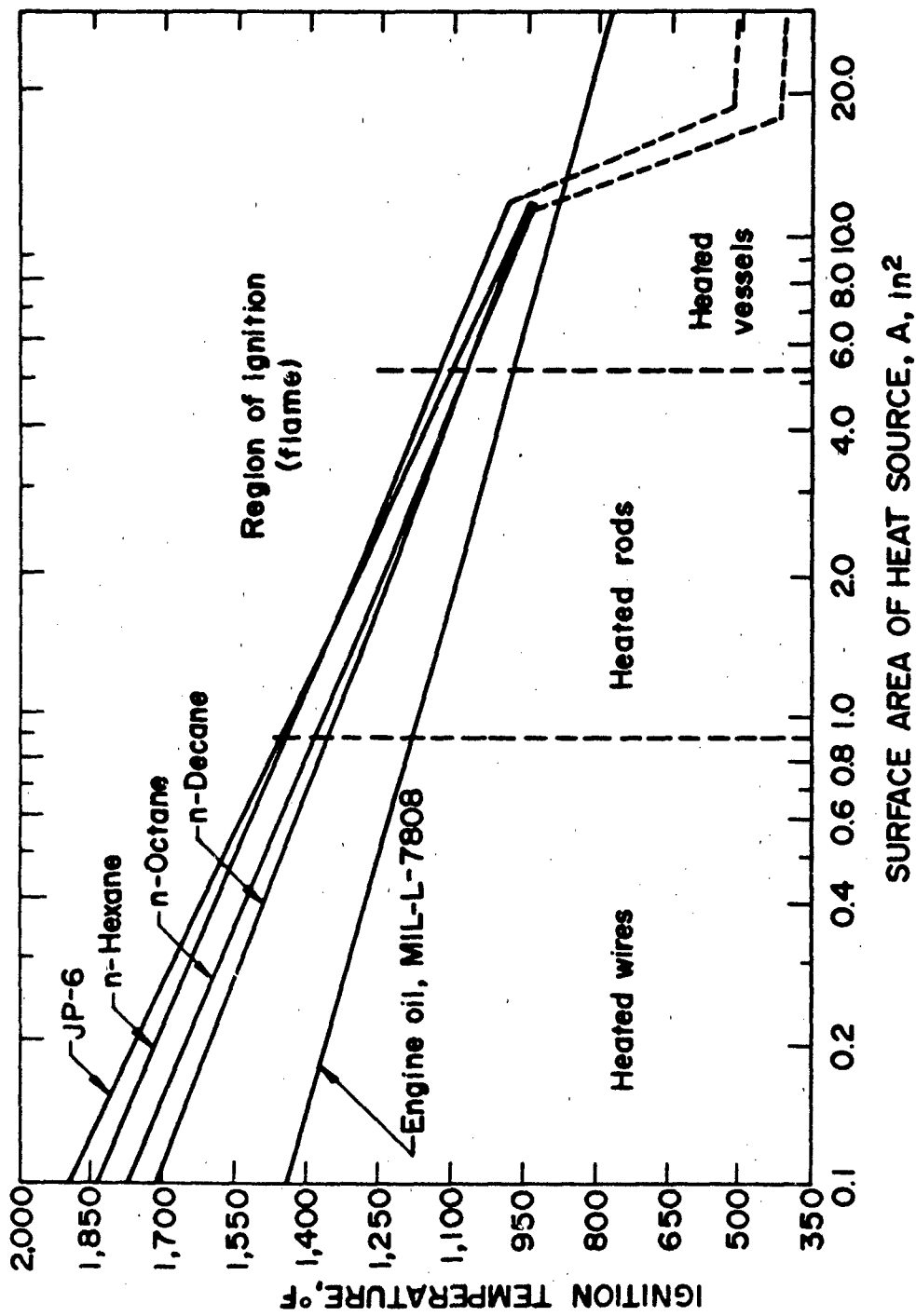

Figure 26. Hot Surface Ignition Temperatures as a Function of the Surface Area of the Heat Source for Various Hydrocarbon Fuels and an Engine Oil in Near Stagnant Air.

the entire range of heat source sizes used. The above equations for JP-6 will roughly approximate the high temperature ignition behavior of other jet fuels since their compositions are similar; volatility effects will be minor as long as flammable vapor-air mixtures can be formed, as in the hot manifold ignitions.

Hot gas ignition temperatures are of interest where jets of hot air or fuel vapor may be discharged into a flammable atmosphere; some examples are the failure of engine seals, bleed air lines, or fuel lines due to a pinhole leak. They are also useful in designing flame arrestors and explosion-proof enclosures. Data for n-hexane, JP-6, and MIL-L-7808 combustibles with various hot air jets are summarized in Table 11 (Ref. 25). As with hot surface ignition sources, the hot gas ignition temperatures decrease with increasing heat source diameter; also, they are lower for the engine oil than the hydrocarbon fuels at the smaller heat source diameters. The greater ease of ignition of the engine oil at the higher temperatures is partly attributable to its lower thermal stability. Hot gas ignition temperatures tend to be noticeably higher than wire ignition temperatures at the same heat source diameter.

TABLE 11 MINIMUM HOT GAS IGNITION TEMPERATURES OF
 HYDROCARBON FUELS AND ENGINE OIL (VAPOR-AIR
 MIXTURES) WITH VARIOUS HOT AIR JETS*

Hot Air Jet Diameter (in)	Ignition Temperature, °F		
	n-Hexane	JP-6	MIL-L-7808
1/8	1910	1985	1605
1/4	1630	1670	1530
3/8	1450	1500	1410
1/2	1260	1410	1250
3/4	1210	1290	1210

* Reference 25

Incendiary ignition sources, such as those from gun firings, involve far greater energy fluxes than those of most hot surface sources. Their surface temperatures can be of the order of 4,000°F or more. Accordingly, such sources are easily capable of igniting flammable vapor-air mixtures of aircraft fuels or lubricants. In fact, their excessive heat can result in fuel tank ignitions at ambient temperatures substantially below the flash points of the fuels. In comparison, nonincendiary ammunition is much less likely to produce a fuel tank ignition, although ignitions are conceivable from severe impact or frictional heating. Since air entrainment will normally accompany any penetration of a fuel tank, fuel rich mixtures can become flammable and ignitable by these external ignition sources.

Frictional ignitions may occur when incendive sparks or localized hot surfaces are generated as a result of severe abrasions or impacts of certain metals or other hard substances. Both thermal and chemical heat may be involved at the outlet depending upon the reactivity of the materials. Reported data (Ref. 26) indicate that aluminum materials have a low frictional spark ignition hazard in aircraft crash situations. Such materials as titanium alloy (Ti-100A), magnesium alloy (FSI), chrome-molybdenum steel (SAE-4130), and

stainless steel (AISI-347) can produce frictional ignitions with such fuels as aviation gasoline, JP-4, kerosene, or SAE No. 5 lubricating oil. Ignitions were obtained at bearing pressures as low as 20 to 50 psi and slide speeds below 50 miles per hour; titanium was most effective with fuel mists. A review of other data (Ref. 10) shows that the impact ignition hazard is great for titanium on steel and for light metal alloys on rusted steel. For aluminum alloys, the hazard varies with the magnesium content.

H. BURNING RATES

The burning velocity of a flammable fuel vapor-air mixture is a fundamental property and defines the rate at which a laminar combustion wave travels relative to the unburned gas. Figure 27 (Ref. 27) illustrates the relationship between the burning velocity (S_u), flame speed (S_f), and gas velocity (S_g) of hydrocarbon (methane) vapor-air explosions as a function of equivalence ratio (ratio of actual fuel/air to stoichiometric fuel/air ratio for complete combustion). The flame velocity sensed by the observer is:

$$S_f = S_u + S_g \tag{32}$$

Note that maximum S_f and S_u values occur on the rich side of stoichiometric and that their ratio (S_f/S_u) is approximately 6, which is typical for most combustibles. This ratio is useful in predicting flame speeds and explosion pressures:

$$S_f = S_u E \tag{33}$$

$$S_f = S_u \rho_u / \rho_b = \frac{S_u M_u T_b P_u}{M_b T_u P_b} \tag{34}$$

where E is expansion ratio, M is molecular weight, T is temperature, P is pressure, ρ is density, and subscripts u and b refer to unburned and burned gas, respectively. The maximum burning velocity of hydrocarbon-type fuels, including jet fuels, is about 1.5 ft./sec. (45 cm/sec.) in air at 77°F and 1 atm; this assumes uniform compositions and laminar flame propagation. Thus, the flame speeds for such mixtures are expected to be approximately 10 ft./sec. by equation 33, using an expansion ratio of 7. The burning velocity generally increases with increased temperature and particularly with increased oxygen concentration or turbulence.

Flame spread rates of combustible liquids are strongly dependent upon the liquid fuel temperature, which is critical to the formation of flammable vapor-air mixtures. At temperatures above their flash points, the flame spread rates above the liquid surface should approximate the flame speeds predictable by equation 38. Figure 28 (Ref. 1) illustrates this point for high volatility (Jet B) and low volatility (Jet A) type jet fuels. Under ventilated or turbulent conditions, the flame propagation rates can be substantially greater than for quiescent conditions.

Regression rates or burning rates of liquid pools are a strong function of pool diameter because of the radiation feedback effect. A pool diameter of about 3 ft. or more tends to give near-maximum rates for most fuels. Figure 29 (Ref. 28) illustrates the diameter effect for several types of fuels. The

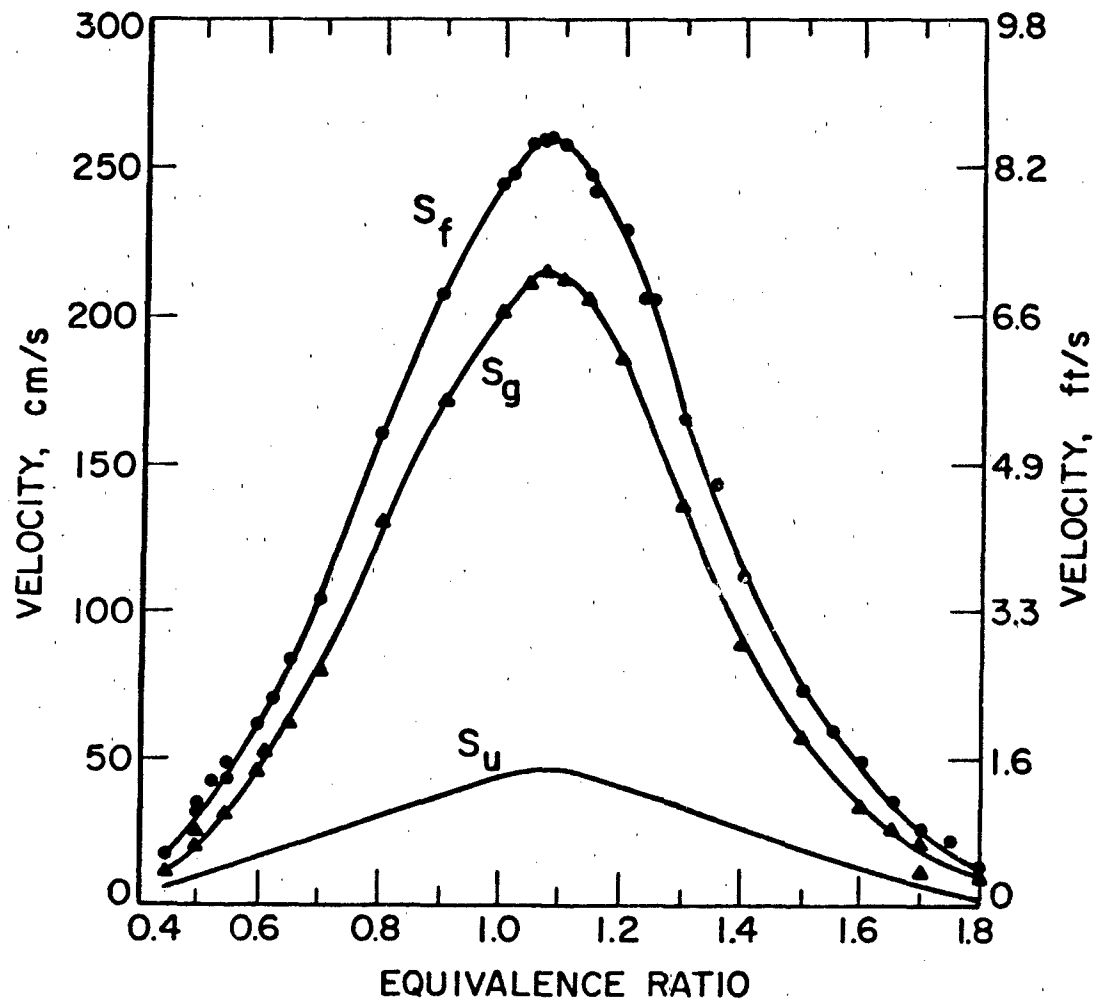

Figure 27. Flame Speed (S_f), Gas Velocity (S_g), and Burning Velocity (S_u) for Different Equivalence Ratios of Methane - Air Explosions at Atmospheric Pressure and 298°K (77°F)

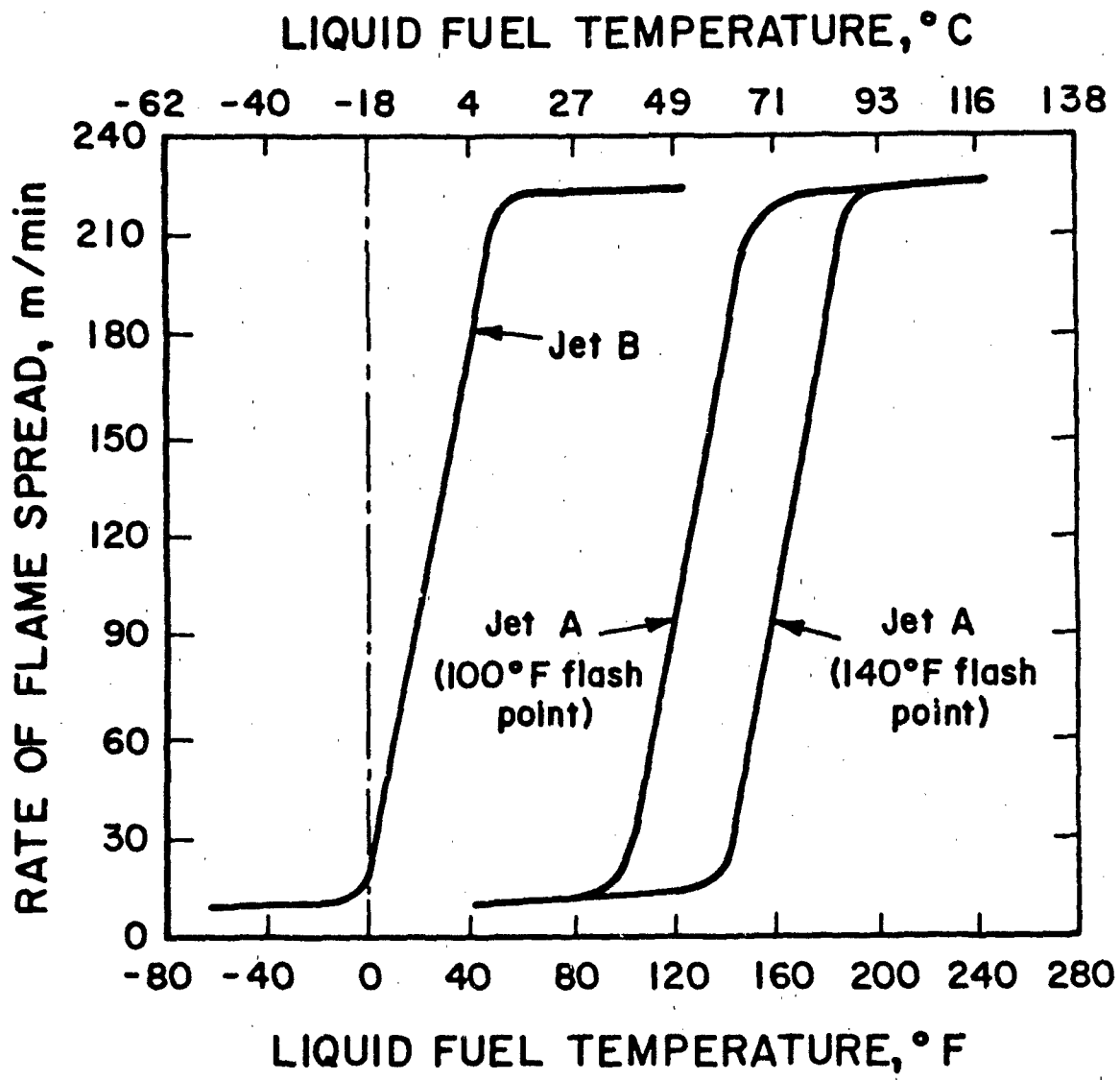

Figure 28. Rate of Flame Spread Versus Liquid Fuel Temperature for Jet A and Jet B Type Fuels in Air at Atmospheric Pressure

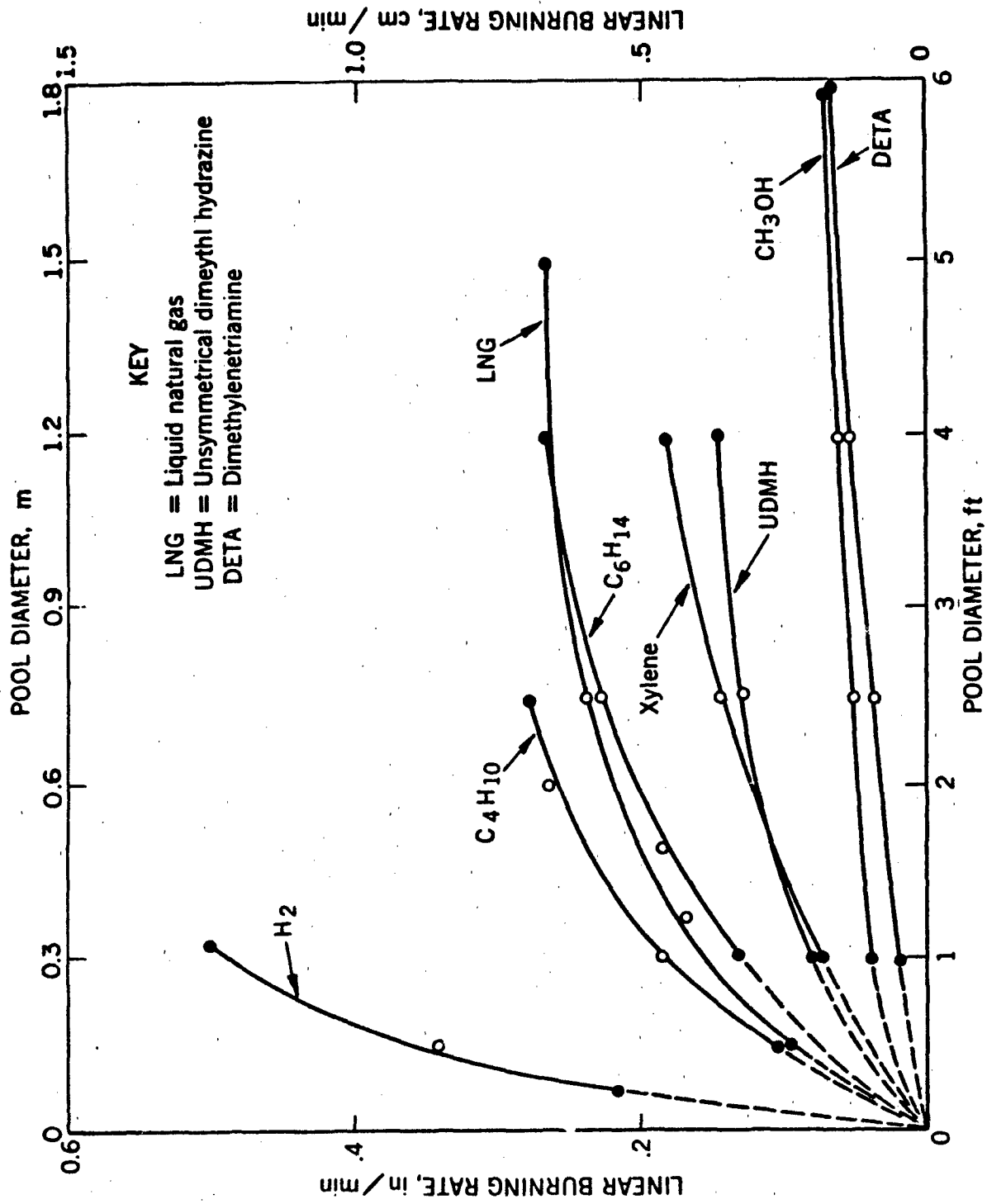

Figure 29. Linear Burning Rate (Regression Rate) of Combustible Liquids as a Function of Pool Diameter

authors of this work found the following expression reliable for predicting maximum pool burning rates:

$$v_{\infty} = 0.003 \frac{\text{Net Heat of Combustion}}{\text{(Sensible Heat of Vaporization)}} \quad (35)$$

when v_{∞} is the linear rate at infinite pool diameter (in/min.). For aircraft jet fuels, the calculated maximum burning rate is approximately 0.35 in/min., which compares favorably with experimental values obtained for gasoline pool fires of 10 feet diameter. For most hydrocarbon fuels, the heat of combustion/heat of vaporization ratio is about 100. Corresponding mass burning rates are simply calculated by:

$$\text{Mass Rate} = \text{Linear Rate} \times \text{Surface Area} \times \text{Liquid Density} \quad (36)$$

The flame height of a pool fire can vary with the pool size and wind conditions but generally will maximize at about twice the pool diameter.

V. PROPERTIES OF AIRCRAFT COMBUSTIBLE SOLIDS

This section summarizes selected physical and combustion properties of aircraft materials such as metals, plastics, rubbers, fabrics, and other combustible-type solids. Table 12 lists such selected properties for combustible metals or nonmetals, most of which represent near-pure chemical elements. Additional data on other combustion properties of these materials and corresponding data for various composite materials are included in other tables or figures of this section. Combustion data for all such solid combustibles are greatly dependent upon their geometrical size and shape, their chemical composition and purity, and the environmental test conditions.

A. FLAMMABILITY LIMITS

Combustible solids have flammability or explosibility limits in an oxidant atmosphere when they are finely divided and dispersed to form flammable dusts. For example, explosions are possible with the fine metal dusts ($\leq 74 \mu\text{m}$) of aluminum, magnesium, and titanium in ambient air at lower limit concentrations of 0.075, 0.030, and 0.045 g/l (oz./ft.³), respectively (Ref. 29); corresponding values for tin and iron dusts are greater than 0.10 g/l. In comparison, the lower dust flammability limits for most plastic or organic dusts are about 0.05 g/l or less. Some combustible solids such as naphthalene, anthracene, phthalic anhydride, and other high-molecular weight organics evolve flammable vapors if heated sufficiently; limit-of-flammability data for combustible vapors are applicable in such cases. Nevertheless, explosions of combustible solids or their vapors are rare in aircraft accidents.

B. IGNITION ENERGIES

Generally, flammable dust-air clouds require much greater spark ignition energies than flammable vapor-air mixtures. The minimum spark ignition energies of most agricultural, carbonaceous, chemical, plastic, and metallic dusts are of the order of 100 mj or less in air at optimum dust concentrations and particle sizes ($\leq 74 \mu\text{m}$); aluminum, magnesium, and titanium have values close to 20 mj.

Of greater interest in aircraft applications are the ignition energies of combustible solids in sheet or other composite forms of the solids. Spark ignitions of combustibles in such composite forms are usually difficult to achieve and often require an oxygen-enriched atmosphere to obtain ignition at relatively low-spark energies. This is illustrated in Table 13 (Refs. 32, 33) in which sheet-type combustibles were exposed to single and multiple spark energy sources.

In all such ignitions, the presence of oil or similar hydrocarbon contaminants will reduce the spark ignition energies substantially.

TABLE 12 PROPERTIES OF COMBUSTIBLE METALS AND NONMETALS*

Metal	Symbol	At. Wt.	Specific Gravity (Water=1)	Melting Point °F	Heat of Combustion Btu/lb.	Ignition Temperature, °F		
						In O ₂ Slab or Rod	In Air Dust Layer	In Air Dust Cloud
Metals								
Aluminum	Al	26.97	2.70	1220	13,400	-	915	1240
Brass	-	-	>8.4	1600	-	-	-	-
Cadmium	Cd	112.41	8.6	610	1,000	1400	480	1060
Chromium	Cr	52.01	6.93	3430	4,750	-	750	1080
Copper	Cu	63.57	8.92	1980	1,070	-	-	1290
Iron	Fe	55.85	7.86	2795	2,000	1710	555	-
Lead	Pb	207.21	11.34	620	460	1600	520	1310
Magnesium	Mg	24.32	1.74	1200	11,600	1160	805	1040
Molybdenum	Mn	95.95	10.20	450	3,430	1380	680	1330
Nickel	Ni	58.69	8.90	2800	1,780	-	-	NI
Silver	Ag	107.88	10.50	1760	65	-	-	-
Stainless steel	-	-	>7.6	2600	2,000	1710	-	NI
Tin	Sn	118.70	7.31	450	2,160	1590	805	1170
Titanium	Ti	47.90	4.50	3100	6,820	1600	950	630
Tungsten	W	183.92	19.30	6100	1,970	-	805	1350
Zinc	Zn	65.38	7.14	785	2,300	1650	1005	1270
Nonmetals								
Carbon	C	12.01	~ 2.3	>6300	14,100	-	-	1345
Sulfur	S	32.06	~ 2.0	235	3,990	-	430	375

* References 29, 30, and 31.

**TABLE 13 SPARK IGNITION OF COMBUSTIBLE SOLIDS
 IN AIR AND OXYGEN AT ATMOSPHERIC PRESSURE***

Combustible	Thickness in.	Single Spark** 800 mj		Repetitive** Sparks (Total) 90 mj-60 SPS	
		Air	Oxygen	Air	Oxygen
Vinyl plastic	0.002	NI	NI	NI	5
Tissue paper	.0025	NI	NI	NI	10
Nylon	.006	NI	NI	NI	30
Wool	.022	NI	NI	NI	5
Cotton muslin	.012	NI	NI	NI	100
Dacron-cotton	.008	NI	NI	NI	100

* References 32 and 33

** NI - No ignition; SPS - Sparks per second

The ignition energy requirements for sheet-type combustibles may also be determined using a thermal radiation source, similar to when a combustible is exposed to fire. According to the data of Table 14 (Ref. 34), radiation intensities of about 50 Btu/ft.² (13.6 cal/cm²) are required for the thermal radiative ignition of cotton sheet fabrics in air and 90 to 120 Btu/ft.² for wood and paper sheeting; the radiant heat flux was 48.7 Btu/ft.²-sec. (13.2 cal/cm²-sec.). In comparison, neoprene, nylon, and polyvinyl chloride sheeting were not ignitable in air with the same radiation source. These ignition energies apply to relatively short heat exposure times and, therefore, do not represent threshold values. Here, the exposure time (seconds) was approximately equal to the ignition energy (Btu/ft.²) divided by the radiant heat flux (48.7 Btu/ft.²-sec.). A threshold radiant heat flux of about 3 Btu/ft.²-sec. (0.8 cal/cm²-sec.) is a conservative value for the ignition of many textile fabrics and wood or cellulose materials in ambient air (Ref. 35).

**TABLE 14 RADIANT IGNITION ENERGIES OF COMBUSTIBLE
 SOLIDS IN AIR AT ATMOSPHERIC PRESSURE***

Combustible	Ignition Energy** Btu/ft. ²	Combustible	Ignition Energy** Btu/ft. ²
Asbestos tape	221	Paint, 3M velvet	37
Cotton shirt fabric	48	Paint, capon	111
Masking tape	83	Paper	118
Neoprene rubber	NI	Plastic wire coating	74
Nylon 101	NI	Polyvinyl chloride	NI
		Wood strips	92

* Reference 34

** NI - No ignition

Radiant flux source of 48.7 Btu/ft.²-sec (13.2 cal/cm²-sec).

C. IGNITION TEMPERATURE

As with combustible liquids, the ignition of a combustible solid occurs when it is heated to some critical temperature above which the reaction can accelerate to produce a flame. Various ignition temperatures are possible for the solids depending upon the heat source characteristics (see Figure 17), sample form and size, ignition criteria, and oxidant atmosphere. Spontaneous combustion temperatures (or self-heating temperatures) normally are associated with slow oxidation that occurs over hours or days at ambient or slightly higher temperatures. They define the temperature at which the heat release of the incipient reaction is just greater than the heat loss and are lowest under adiabatic conditions; here, temperature rise is taken as evidence of an exothermic reaction. Materials which are most susceptible to self-heating at normal ambient temperature include cereal grains, bituminous or subbituminous coals, linseed oils, and other vegetable oil products.

In practice, most combustible solids require elevated temperatures to undergo self-heating or self-ignition; also, such determinations are often made under isothermal conditions and relatively short heating periods, thereby requiring higher reaction temperatures than under adiabatic heating conditions of long duration. The ignition temperatures of various metals, synthetic rubbers, wood or fibrous materials, and miscellaneous substances in air are given in Table 15 (Ref. 36); here, a substantial exothermic reaction was the ignition criterion. Note that these self-ignition temperatures are over 300°F for nearly all test materials and over 1200°F for metal powders, silk or nylon parachutes, and a few other materials; sample size effect is indicated by the data for magnesium and rubber samples.

Similar ignition temperature data for various metal or nonmetal dusts are included in Table 12. It is apparent that the ignition temperatures in air are noticeably greater for dust clouds than for dust layers of the combustibles, except for titanium. This effect is also evident in Table 16 (Ref. 37) for ignitions of plastic or rubber type materials. The ignition criterion for the dust layer ignition temperatures was a noticeable temperature rise. In the use of the dust layer ignition temperatures, one must realize that lower values are possible under adiabatic conditions, such as that simulated by a large pile of combustible.

Generally, the ignition temperatures of combustible solids are greater when the solids are in sheet or slab form, which offer less surface area for reaction than a finely divided solid; also, they are greater when they are nonuniformly heated as in a hot plate type ignition. Table 17 (Ref. 38) compares the minimum autoignition temperatures (AIT's) of sheet-type combustibles in uniformly heated vessels with their corresponding hot plate ignition temperatures in air and oxygen; here, the appearance of flame was the ignition criterion. These data show that the ignition temperatures are not only higher with the hot plate source, but also that they are significantly lower when the oxidant is purely oxygen or an oxygen-enriched atmosphere. Note also that the addition of a fire retardant to cotton sheeting may not be effective in oxygen-enriched atmospheres. One may assume that such ignition temperatures in oxygen at 1 atmosphere will be roughly equivalent to those in air at 6 atmospheres, indicating the importance of oxygen partial pressure.

**TABLE 15 IGNITION TEMPERATURES OF
 COMBUSTIBLE SOLIDS IN AIR***

Material	Type of Specimen	Temperature °F
<u>Woods and Fibrous Materials</u>		
Short-leaf pine	Shavings	442
Long-leaf pine	Shavings	446
Douglas fir	Shavings	500
Spruce	Shavings	502
White pine	Shavings	507
Paper, newsprint	Cuts	446
Paper, filter	Cuts	450
Cotton, absorbent	Roll	511
Cotton, batting	Roll	446
Cotton, sheeting	Roll	464
Woolen blanket	Roll	401
Viscose rayon (parachute)	Roll	536
Nylon (parachute)	Roll	887
Silk (parachute)	Roll	1058
Wood fiberboards	Piece	421 to 444
Cane fiberboard	Piece	464
<u>Synthetic Rubber</u>		
GR-S (R-60) black	Coagulum	590
GR-S (R-60) black	Buffings	374
GR-S black	Coagulum	563
GR-S black	Buffings	320
GR-S, Indulin	Crumb	824
<u>Metals</u>		
Aluminum paint flakes	Fine powder	959
Tin	Fine powder	842
Tin	Coarse powder	1094
Magnesium	Fine powder	883
Magnesium	Coarse powder	950
Magnesium ribbon	Cuts	1004
Magnesium, cast	Piece	1144
Magnesium-Al-Zn-Mn alloys (Mg 89% or more)	Piece	860 to 1256
Zinc	Fine powder	1202
<u>Miscellaneous</u>		
Nitrocellulose film	Roll	279
Matches (strike anywhere)	Heads	325
Carbon spot	Dust	366
Crude pine gum	Powder	581
Shellac	Scales	810
Paint film, oxidized linseed oil-varnish	Powder	864

* Reference 36; values refer to lowest temperatures at which exothermic reaction (oxidation) may self-accelerate to ignition under isothermal heating conditions.

TABLE 16 IGNITION TEMPERATURES OF PLASTIC AND RUBBER DUSTS IN AIR*

Material	Ignition Temperature, °F	
	Dust Layer	Dust Cloud
Acrylonitrile polymer	860	930
Cellulose acetate	-	790
Epoxy (no catalyst)	-	1005
Melamine formaldehyde, laminate	-	1455
Methyl methacrylate	-	825
Nylon, polyamide	805	930
Polyethylene, hi-pressure	715	840
Polystyrene	-	915
Polyurethane foam, nonfire retardant	825	950
Polyurethane foam, fire retardant	735	1020
Polyvinyl chloride, fine	750	1220
Rayon, viscose	480	970
Rubber, crude, hard	-	660
Rubber, synthetic, hard (33% S)	-	610
Rubber, chlorinated	555	1725

* Reference 37; dust particle size < 74 μm (-200 mesh).

TABLE 17 HEATED VESSEL AND HOT PLATE IGNITION TEMPERATURES OF FABRIC OR SHEET COMBUSTIBLES IN AIR AND OXYGEN AT ATMOSPHERIC PRESSURE*

Material	Density oz/yd. ²	Ignition Temperature, °F		
		Heated Vessel	Hot Plate	
		Air	Air	Oxygen
Cellulose acetate sheet	10.7	1020	>1110	795
Natural rubber sheet	14.75	735	895	680
Conductive tygon tubing	-	780	-	-
Cotton sheet	4.72	725	870	680
Cotton sheet, fire retardant	-	805	1065	590
Nomex sheet	3.0	960	>1110	970
Paper drapes (sanidrapes)	1.56	750	880	770
Plexiglas sheet	23.8	840	1105	805
Polyvinyl chloride sheet	14.6	1040	>1110	735
Wool blanket	21.0	1005	>1110	930

* Reference 38

Table 12 also includes ignition temperatures in oxygen for some of the metals in slab or rod forms. The high ignition temperatures in such an oxidant atmosphere indicate the difficulty in achieving ignition of solids that are not finely divided. Although one might assume that ignition of such bulk materials should occur above their melting points, the data are not fully consistent in this respect. Where the ignition temperatures are very much higher than the melting points of the pure metals, these values can be attributable to the high melting points of their metal oxides that coat the metal surface before reaction.

D. BURNING RATES

Theoretically, the burning rate of a combustible solid is the rate at which the combustion front advances through the unreacted material. The burning rate may be used to calculate the heat release rate as follows (typical English units are also given):

$$q = r A_s \rho Q_c \quad (37)$$

where q is heat release rate (Btu/sec.), r is burning rate (in/sec.), A_s is cross-sectional area of burning solid (in.²), ρ is bulk density or loading density of solid (lb/in.³), and Q_c is heat of combustion (btu/lb.). Of great practical interest in a fire is the rate of flame spread across the burning surface. Flame spread rates are greatest with upward burning and lowest with downward burning because of buoyancy and other convective effects (Table 18). Flame spread rates of sheet combustibles approximate burning rates when the burning is in the vertically downward direction.

**TABLE 18. BURNING RATES AND FLAME SPREAD RATES
 BY VARIOUS METHODS FOR COTTON SHEETING
 IN AIR AT ATMOSPHERIC PRESSURE***

Burning Mode	Burning Rate in/sec.	Flame Spread Rate in/sec.
Vertical, upward	0.5	2.1
45° angle, upward	0.45	0.8
Horizontal	<0.1	0.1
Vertical, downward	0.05	0.05

* Reference 38

Table 19 (Ref. 38) summarizes flame spread rates obtained with upward burning (45° angle) of small samples of various fabric or sheet combustibles in air and oxygen atmospheres. Such materials as cotton (untreated), paper, plexiglas, and wood propagated flame in an atmosphere of air, whereas fire retardant cotton, natural rubber, fire retardant nomex, polyvinyl chloride, and cellulose acetate materials required elevated air atmospheres or oxygen-enriched atmospheres. The materials in Figure 30 correlated the best with oxygen partial pressure over a wide range of oxygen percentages (>21%) and total pressures (1 to 6 atm). Generally, the rates for most materials at a given oxygen partial pressure were lower in oxygen-nitrogen than in oxygen

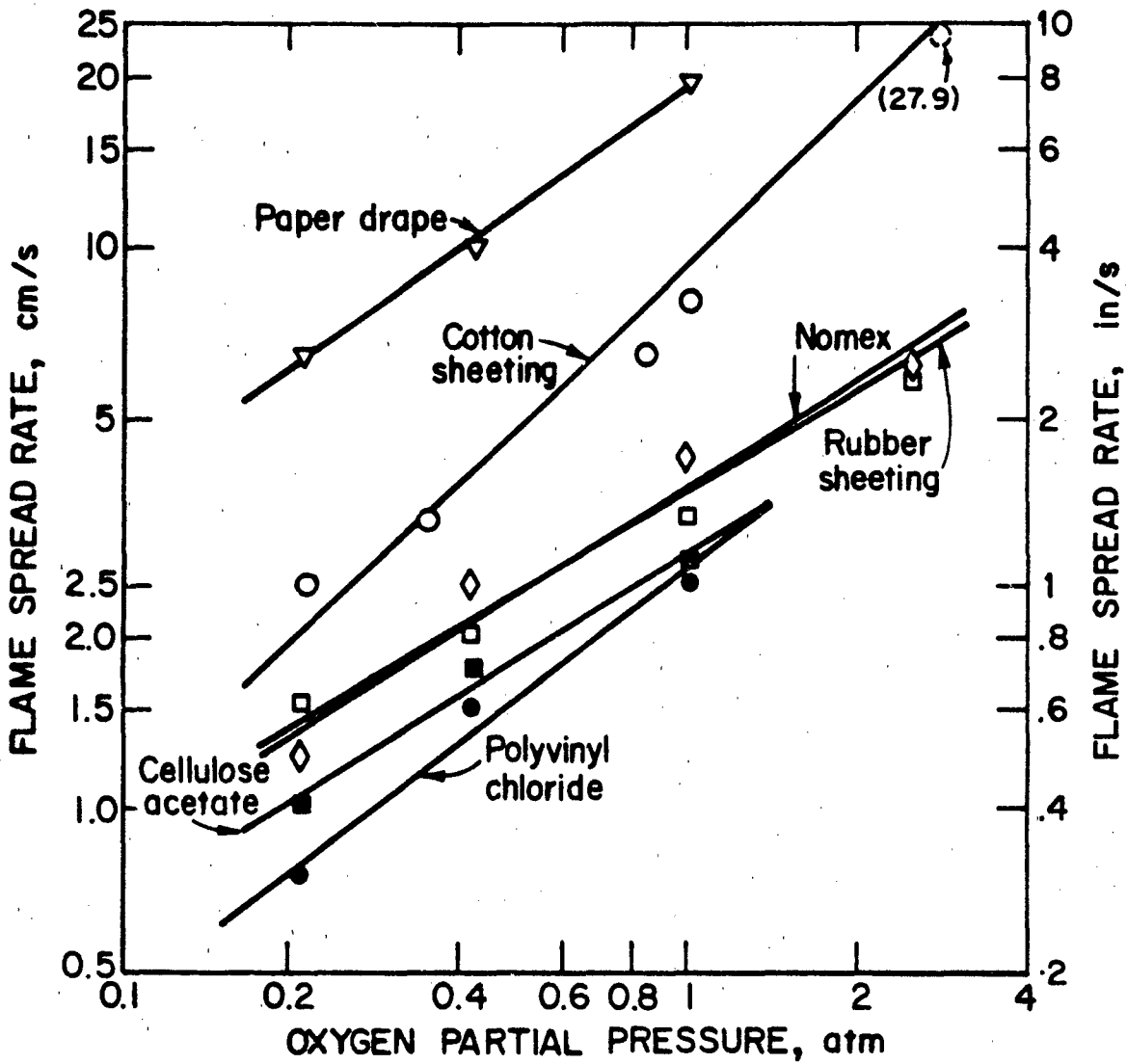

Figure 30. Effect of Oxygen Partial Pressure on the Flame Spread Rates of Materials in Oxygen-Nitrogen Mixtures at 1 to 6 Atmospheres Total Pressure (Upward burning at 45° angle)

atmospheres. The highest rates are found when materials can undergo nap-type burning; wool is one example (see Table 20).

TABLE 19 FLAME SPREAD RATES (45° ANGLE UPWARD) OF FLAMMABLE FABRICS OR SHEET COMBUSTIBLES IN AIR AND OXYGEN ATMOSPHERES*

Material	Density oz/yd. ²	Flame Spread Rate, in/sec.		
		1 atm Air	6 atm Air	1 atm Oxygen
Cellulose acetate sheet	10.7	NB	NB	1.1
Natural rubber sheet	14.75	NB	1.8	1.3
Cotton sheet	4.72	0.8	3.0	3.2
Cotton sheet, fire retardant	-	NB	NB	1.7
Nomex sheet	3.0	NB	0.7	1.7
Paper drapes (sanidrapes)	1.56	2.0	4.0	7.7
Plexiglas sheet	23.8	0.2	1.4	-
Polyvinyl chloride sheet	14.6	NB	NB	1.0
Wool blanket	21.0	NB	NB	100**
Wood strips, white pine	49.3	0.2	0.7	1.1

* Reference 38; NB - no sustained burning.

** Nap burning with flash propagation.

Other flame spread data for sheet-type combustibles are given in Table 20 (Ref. 34). These data were obtained with small samples burning in the downward direction. Note that fire-resistant type materials failed to ignite in air (1 atm) and that Teflon and Kel-F samples did not ignite even in oxygen (1/3 atm). However, practically all fire-resistant type combustibles can burn in oxygen at a total pressure of 1 atmosphere. The rates in both Tables 19 and 20 should be taken as minimum values in any fire assessment because radiation, convection, and other factors can greatly enhance the burning in a full-scale fire situation.

In the case of combustible metals, their flame spread is low unless they are in a finely divided state, such as a fine dust. For a particle size of about 100 mesh (149 μ), a flame spread rate of approximately 1.3 in/sec. for titanium and 0.5 in/sec. for magnesium may be expected in the horizontal burning of such materials in atmospheric air (Ref. 39); aluminum dusts would give values somewhat lower to those of magnesium. In comparison, a standard red oak sawdust would have a flame spread rate of approximately 0.05 in/sec.

**TABLE 20 FLAME SPREAD RATES (DOWNWARD BURNING) OF SHEET-TYPE
 COMBUSTIBLES IN AIR AND OXYGEN ATMOSPHERES***

Material	Flame Spread Rate in/sec.		Material	Flame Spread Rate in/sec.	
	1 atm Air	1/3 atm O ₂		1 atm Air	1/3 atm O ₂
Aluminized mylar	0.20	1.95	Paper	0.08	0.90
Butyl rubber	0.006	0.40	Polyethylene	0.014	0.25
Cotton shirt	0.10	1.50	Polystyrene	0.032	0.80
Cellulose acetate	0.102	0.28	Flexiglas	0.005	0.35
Foam cushion	0.19	12.40	Plastic wire coat	NI	0.84
Kel-F	NI	NI	Polyvinyl chloride	NI	0.10
Natural rubber	0.01	0.61	Silicone rubber	NI	0.14
Neoprene rubber	NI	0.32	Teflon	NI	NI
Nylon 101	NI	0.19	Tygon tubing	0.18	0.50
Paint, 3 M velvet	NI	0.15	Viton	NI	0.003
Paint, Capon	NI	0.38	Wood	0.025	0.35

* Reference 34; NI - no ignition.

VI. PROPERTIES OF HYDRAZINE

Hydrazine is used by the Air Force as a special fuel on several military aircraft or flight vehicles. Some physical and combustion properties of this fuel are summarized in Table 21.

TABLE 21 PROPERTIES OF HYDRAZINE*

Formula	N_2H_4	Heat of Formation, Btu/lb (gas)	1280**
Molecular Weight	32.05	Heat of Combustion, Btu/lb	7750**
Liquid Density, lb/ft. ³	62.68**	Flash Point, °F	100
Specific Gravity (air = 1)	1.1**	Minimum AIT in Air, °F	518
Boiling Point, °F	237	Flammability Limits in Air -	
Freezing Point, °F	36	L (vol. %)	4.7
Vapor Pressure, psia	0.278**	U (vol. %)	100
Heat of Vaporization, Btu/lb	539	Stoichiometric Concentration	
		C _{st} in Air (vol. %)	17.32

* Data from engineering handbooks and NFPA Handbook (Ref. 6).

** Data at 25°C (77°F).

Hydrazine is a highly reactive fuel and capable of propagating flame even in the absence of air; thus, it can be used as a monopropellant. The flammability range for the vapors of this fuel in air is 4.7 to 100 vol. % at temperatures above the flash point (100°F). Explosive decomposition of the fuel vapor without an oxidant will yield hydrogen, nitrogen, and ammonia. A decomposition flame is possible at very low pressures (<1 psia) with this fuel, depending upon apparatus dimensions.

The autoignition temperature of hydrazine is particularly sensitive to the environmental pressure and nature of the container or heated surface. This is shown by the data in Table 22. An additional fire hazard of hydrazine is that it is hypergolic with fluorine, nitrogen tetroxide, or other such strong oxidizers (Ref. 12). Because of hydrazine's high reactivity, its inerting or extinguishing requirements are substantially greater than those for ordinary aircraft fuel fires.

**TABLE 22 PRESSURE AND SURFACE EFFECTS ON AUTOIGNITION
 OF HYDRAZINE VAPOR MIXED WITH AIR**

	Vessel Pressure, mmHg *			
	760	400	100	50
Minimum AIT, °F				
200 cc Vessel	518	558	-	-
4900 cc Vessel	352	-	810	885
	Vessel Surface **			
	Glass	St. Steel	Black Iron	Iron Rust
Minimum AIT, °F @ 760 mmHg				
≤ 200 cc Vessel	518	313	270	74

* Data from Ref. 41.

** Data from Ref. 6, 40.

VII. PROPERTIES OF EXPLOSIVES

A. DETONATION PROPERTIES

Many combustible materials or systems can be considered as explosives if one accepts the loose definition of an explosive as any material capable of exploding. Classically, explosives are categorized as high or low explosives. High explosives are typically highly energetic solids or liquids that are capable of detonation (supersonic propagation rate) even without any confinement. Obviously, detonable gaseous systems would not qualify since they require confinements. The detonation properties of some commonly used high explosives are given in Table 23 (Ref. 42). The primary high explosives are highly sensitive to heat, shock, or electrical discharge and are used in detonators, squibs, or blasting caps for initiating high explosive materials; they are also used in initiating gun propellants most of which are not high explosives. Secondary high explosives are less sensitive and may require both primary and secondary high explosives for their initiation. For example, tetryl or pentolite are often used to initiate a TNT, dynamite, or other low sensitivity explosive. Dynamite normally contains nitroglycerine and some ammonium nitrate which requires a high energy stimulus for detonation.

Low explosives are those materials which may explode but only produce deflagrations (subsonic propagation rates). These include black powder and smokeless gun powders which are not normally considered to be detonable materials. Black powder, which contains potassium or sodium nitrate, sulfur, and charcoal, presents a greater ignition hazard than the smokeless gun powders, many of which are nitrocellulose based materials.

The heats of detonation in Table 23 are important in determining the TNT explosive equivalent of any exploding system. TNT has a maximum value of 2,520 Btu/lb. (1400 cal/g) assuming that water is formed as a liquid in the explosion products; a lower value results if water is in the vapor state. In practice, a TNT heat of detonation of 1100 cal/g or 2,000 Btu/lb. is considered more realistic for air blast situations (Ref. 19). Note that for most secondary high explosives, their detonation pressures are over 200,000 atmospheres and the velocities of their detonation waves are over 20,000 ft/sec. (>6,100 m/sec.).

The high level of the detonation velocities for the high explosives can be appreciated by comparing them to those of gun projectiles. For example, the standard muzzle velocities of 50 caliber armor piercing incendiaries (API) and 30 caliber M-1 (Army) incendiaries are only about 2400-2800 ft/sec.

TABLE 23 PROPERTIES OF EXPLOSIVES*

Explosive	Molecular Weight	Nominal Density lb/ft. ³	Heat of** Detonation		Detonation** Velocity ft./sec.	Detonation** Pressure 1000 atm
			Btu/lb.	cal/R		
<u>Primary High Explosives</u>						
Lead azide, PbN ₆	291.3	300	661	367	16,990	-
Lead styphnate, PbC ₆ H ₃ N ₃ O ₈	450.3	194	823	457	17,060	-
Mercury fulminate, C ₂ N ₂ O ₂ Hg	284.6	295	769	427	16,400	-
<u>Secondary High Explosives</u>						
Baratol, 24% TNT + 76% Ba (NO ₃) ₂	-	162	1010	560	15,970	139
Comp B, 36% TNT + 63% RDX	-	107	2755	1530	26,210	292
LX-04-1, 85% HMX + 15% Viton A	-	116	2555	1420	27,750	356
Nitrocellulose, Guncotton, >13.35% N	274.1	99	2270	1260	23,940	208
Nitroglycerine, Propanetriol trinitrate	227.1	99	2860	1590	25,260	250
Nitromethane	61.0	71	3490	1940	20,730	139
PETN, pentaerythritol tetranitrate	316.2	110	2970	1650	27,220	302
Pentolite, 50% TNT + 50% PETN	-	104	2735	1520	24,500	246
RDX, trinitrotriazacyclohexane	222.1	114	2915	1620	28,340	335
Tetryl, trinitrophenylmethylnitramine	287.0	107	2735	1520	25,750	248
TNT, trinitrotoluene	227.1	102	2520	1400	22,730	218

* Reference 42.

** Calculated or observed values; heats of detonation refer to gross or maximum values with water formed as liquid.

VIII. PROPERTIES OF FIRE EXTINGUISHANTS

Halons and aqueous foams are among the most widely used extinguishants in aircraft fires. Properties of such extinguishing systems are briefly summarized herein. The NFPA Fire Protection Handbook (Ref. 6) and National Fire Codes (Volume 10) may also be consulted.

A. HALONS

Halons are halogenated hydrocarbons, which are attractive as fire extinguishants because of their action as chemical flame inhibitors. The physical properties of seven common Halons are summarized in Table 24. Those which have low boiling points, such as Halon 1301 (-72°F B.P.) and Halon 1211 (25°F B.P.), can be used both as fire extinguishants and inerting agents. As discussed earlier in the section on inerting requirements for combustible liquids or gases, the Halons are much more effective than inert gases (N₂, CO₂, etc.) for preventing ignitions of fuel vapor-air mixtures. The Halon fire extinguishing systems that are in use on specific military aircraft are identified in Table 24.

In practice, the design requirements for aircraft fire extinguishing systems will vary with the confinement, occupancy, and nature of the fire source. Because of potential toxicity problems, Halon fire suppression systems are used primarily in unoccupied areas such as cargo bays, engine bays, or engine nacelles. Table 25 summarizes the military specifications for two types (fixed) of aircraft engine fire extinguishing systems that employ Halons 1011, 1202, and 1301 as the agents. The highly vaporizable agents are not always suitable for use against Class A type surface fires (e.g., paper, wood, etc.) since they can be deep-seated and difficult to be reached by a gaseous agent; liquid agents are best for deep-seated fires.

TABLE 25 AIRCRAFT FIXED FIRE EXTINGUISHING SYSTEMS*

System	Specification	Agent	Agent** Quantity (lbs.)	Discharge Direction	Discharge Outlets
Conventional	MIL-E-5352	Halon 1011 Halon 1202	$W = 0.59 W_a + 0.16 V$	≤ 2 sec.	Perforated Tubes
High Rate	MIL-E-22285	Halon 1301 Halon 1202	$W = 0.05V$ $W = 0.02 V + 0.25 W_a$ (whichever is higher)	≤ 1 sec.	Open Ended Lines

* Reference 43.

** V = Net volume of zone in cu.ft.

W_a = Air flow (normal cruise) in lb/sec.

**TABLE 24 PHYSICAL PROPERTIES OF HALOGENATED
 HYDROCARBON FIRE EXTINGUISHANTS***

Chemical Name	Halon No.	Molecular Wt.	Freezing Point (°F)	Boiling Point (°F)	Critical Temp. (°F)	Density (Liquid) @ 70 °F (lbs/gal)	Storage Thermal Stability (°F)
Carbon Tetrachloride	1040	154	-9	170	341	13.2	400
Methyl Bromide	1001	95	-135	38	381	14.4	-
Bromochloromethane (CB)	1011	129	-125	153	567	16.1	250
Dibromodifluoromethane (DB)	1202	210	-223	73	390	19.0	350
Bromotrifluoromethane (TB)	1301	149	-282	-72	154	13.1	>500
1,2 Dibromotetrafluoroethane	2402	260	-167	117	418	18.0	>500
Bromochlorodifluoromethane	1211	165	-257	25	309	15.3	400

* Reference 43.

NOTES:

	C	F	Cl	Br	Formula
Halon	1	0	1	1	CF ₂ ClBr
Halon	1	2	0	2	CF ₂ Br ₂
Halon	1	3	0	1	CF ₃ Br
Halon	2	4	0	2	C ₂ F ₄ Br ₂

Halon 1011

C-130 (All)
 C-123

Halon 1202

C-5
 C-141A/B
 F/FB-111
 C/AC/HC-130B/E/H (Alternate)

Halon 1301

A-10
 F/TF-15A/B
 OV-10
 H/CH-53
 E-3A
 E-4A

None

B-52 (All)
 C-135 (All)
 F-4 (All)
 F-5 (All)
 F-16A/B
 T-38
 T-37

B. AQUEOUS FOAMS

In a survivable aircraft crash, it is of utmost importance to envelop the aircraft with a fire extinguishant as rapidly as possible to permit the safe egress of the crew and passengers. An aqueous film forming foam (AFFF), which is similar to "light water," is highly suitable for this purpose. Full-scale fire extinguishing tests by the Federal Aviation Administration (FAA) have shown that Jet A fuel fires can be controlled by the AFFF agent at an application rate of about 0.02 gal./min.-ft.² (Figure 31) (Ref. 44). Furthermore, if the application rate is greater than 0.1 gal./min.-ft.², fire extinguishment may be achieved in less than 30 seconds with either U. S. Air Force or U. S. Navy fire-fighting vehicles.

The AFFF agent is a low expansion foam having an expansion ratio less than 100. Low expansion foams provide greater cooling capacity and greater penetration to the "seat" of the fire than do high expansion foams.

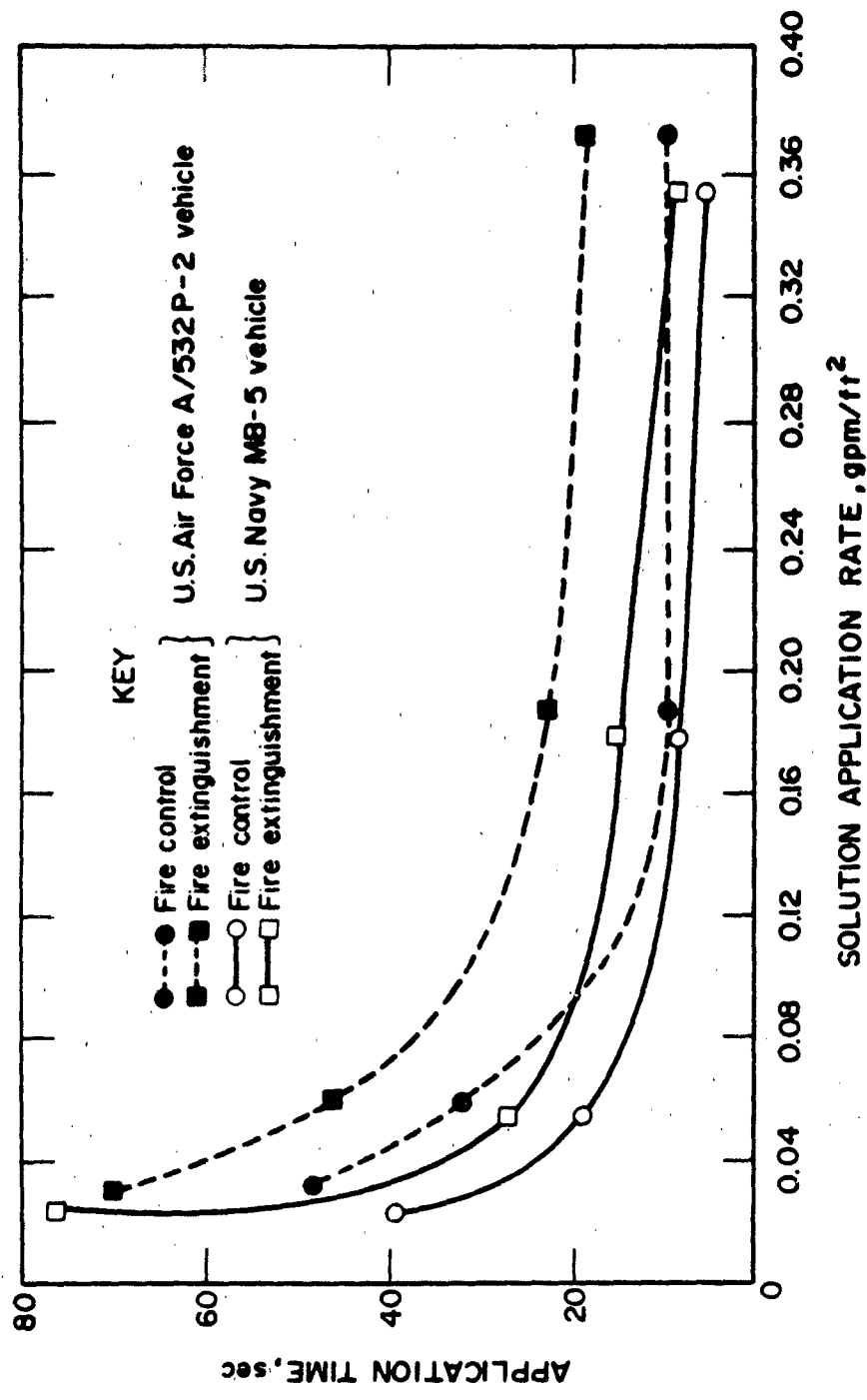

Figure 31. Fire Control and Extinguishing Times as a Function of APFF Solution Application Rate for Jet A Fuel Fires Using Air Force and Navy Fire-Fighting Vehicles

IX. FIRE DAMAGE ANALYSIS

Qualitative guidelines for conducting an aircraft fire damage analysis have been summarized in the section on "Investigative Procedures." Quantitative and additional qualitative guidelines are given in this section with the emphasis on characteristic fire temperatures, heat damage criteria, and fire damage patterns. Supporting data are found in the sections on properties of aircraft combustibles.

A. FIRE TEMPERATURES OF GASEOUS FUELS

Fire damage to materials results primarily from exposure to high levels of temperature and thermal radiation produced by the fire. Although fires usually have ill-defined flames, their maximum temperatures may be estimated from available data for premixed flames. Since aircraft jet fuels are hydrocarbon-type fuels, their flame temperatures will approximate those of such materials. Of primary interest is the limit flame temperature which defines the lowest temperature at which a normal flame can exist (lower limit mixture) and the maximum flame temperature which is obtained for the most optimum fuel-oxidant composition (near-stoichiometric mixture). At constant pressure and adiabatic conditions, the theoretical flame temperatures of most organic fuel vapor-air mixtures (80°F, 1 atm) will fall between the following approximate limits:

$$\begin{aligned} \text{Limit Flame Temperature in Air} &= 2300^{\circ}\text{F} \pm 100^{\circ} \\ \text{Maximum Flame Temperature in Air} &= 3600^{\circ}\text{F} \pm 200^{\circ} \end{aligned}$$

Theoretical flame temperatures of gaseous fuels are higher than their observed values because the fire conditions are seldom adiabatic, the reacting fuel and air (or other oxidant) are not necessarily uniformly mixed, and oxygen concentration is often non-ideal; higher temperatures also result from neglecting dissociation of gaseous products. Rigorous flame temperature calculations are described in Reference 18. A crude method for approximating the lower limit flame temperature of fuel vapor-air mixtures is given below using propane; assume lower flammability limit is nominally 2.0 volume percent (see Appendix A):

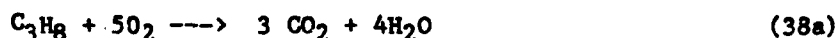
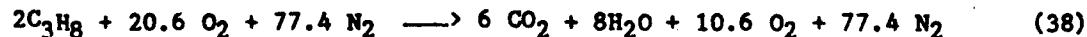

$$\text{Fuel/Air Volume Ratio} = \frac{2}{20.6 + 77.4} = 0.020$$

$$\text{Fuel/Air Weight Ratio} = \frac{2 \times 44}{20.6 \times 32 + 77.4 \times 28} = 0.031$$

$$T_2 = T_1 + \Delta T = T_1 + \frac{L \Delta H_c}{100 C_p} \quad (39)$$

where T_2 is flame temperature ($^{\circ}\text{F}$), T_1 is initial temperature ($^{\circ}\text{F}$), L is lower limit (vol. %), ΔH_c is heat of combustion (Btu/lb-mole), and C_p is average heat capacity over the temperature range (Btu/lb-mole- $^{\circ}\text{F}$). Since the lower limit mixture is largely air, one may take the $\overline{C_p}$ of air here (~ 8.0 Btu/lb-mole- $^{\circ}\text{F}$), yielding

$$T_2 = 75^{\circ} + \frac{2.0 (878,710)}{100 (8.0)} = 2270^{\circ}\text{F}$$

If the reported lower limit of flammability of 2.1 vol.% had been used, the limit flame temperature would have been 2385 $^{\circ}\text{F}$ and more consistent with literature values.

Two fuels which have noticeably lower limit flame temperatures than most hydrocarbon fuels are acetylene ($\sim 1850^{\circ}\text{F}$) which tends to form sooty flames and hydrogen ($\sim 1450^{\circ}\text{F}$) whose flame is greatly transparent. However, their maximum flame temperatures in air are about 4200 $^{\circ}\text{F}$ for acetylene and 3750 $^{\circ}\text{F}$ for hydrogen (Ref. 18). Fuel-rich sooty flames generally will have lower temperatures than fuel-lean flames.

B. FIRE TEMPERATURES OF SOLID FUELS

Flame temperatures of organic combustible solids will depend largely upon the composition of their vapors and availability of oxygen during their pyrolysis and subsequent combustion. Their maximum flame temperatures will approximately correspond to those of the organic compounds (hydrocarbon, substituted hydrocarbon, etc.) which comprise the solids. Theoretical adiabatic values for various plastic or polymer materials are given in Table 26 (Ref. 45); they are calculated values for stoichiometric fuel-air concentrations of the organic monomer that makes up the polymer. As noted, the maximum flame temperatures are between 1900°C (3452°F) and 2200°C (3992°F) for nearly all the plastic materials. Paper, wood, and other cellulosic materials would have similar temperatures in a fire.

Metal combustibles have higher flame temperatures than most organic combustibles because of their high melting points and boiling points. Furthermore, the presence of any metal oxides will require even higher temperatures to sustain the flame. Table 27 (Ref. 31) lists the theoretical adiabatic combustion (flame) temperatures for various metals and nonmetals in an oxygen atmosphere. For such aircraft construction materials as aluminum, titanium, and iron (or steel), the maximum adiabatic flame temperatures are about 2700°C (4892°F) or higher. In both air and oxygen, the flames temperatures will tend to be at least as high as the boiling point of the metallic element, although some data are inconsistent. Also, high flame temperatures usually tend to reflect high molar heats of combustion but the converse is not necessarily true for metals whose oxide products have widely different properties.

As with gaseous fuels, the maximum theoretical flame temperatures are not realized in practice because of non-ideal conditions. The actual flame temperature of the solid materials cited above can easily be a few hundred degrees less than their theoretical values.

**TABLE 26 THERMOCHEMICAL PROPERTIES OF
PLASTICS OR POLYMER MATERIALS***

Material	Heat of Combustion kcal/g-mole	Heating Value Btu/lb.	Maximum Flame Temperature (in air)	
			°C	°F
Polyacrylonitrile	-408.6	13,860	1860	3380
Polyester, unsaturated	-723.2	12,810	2250	3910
Polyether, chlorinated	-660.7	7,673	1990	3610
Polyethylene, high density	-312.5	20,050	2120	3850
Polyethylene, low density	-312.0	20,020	2120	3850
Polyethylene oxide	-280.6	11,470	2120	3850
Poly-1,4-butadiene, atactic	-584.3	19,440	2220	4020
Polymethyl methacrylate	-637.7	11,470	2070	3760
Polypropylene, atactic	-467.8	20,010	2120	3850
Polystyrene, atactic	-1033	17,850	2210	4010
Polytetrafluoroethylene	+8.0	-144	-	-
Polytetrahydrofuran	-592.7	14,790	2120	3850
Polyurethane, ester-based	-743.1	10,180	2100	3810
Polyvinyl chloride	-268.0	7,720	1960	3550
Polyvinyl fluoride	-238.8	9,180	1710	3100
Polyvinylidene chloride	-232.4	4,315	1840	3340
Butadiene/styrene (25.5%)	-650.5	19,010	2220	4020
Epoxy, bisphenol A	-1700	14,430	2220	4030
Melamine-formaldehyde (1:3)	-749.3	8,310	1990	3610
Phenol-formaldehyde (1:1)	-1496	12,000	1860	3380
Urea-formaldehyde (1:2)	-358.8	7,680	1950	3540
Cellulose	-1011	7,520	-	-
Paper	-	7,590	-	-
Wood	-	8,835	-	-

* Reference 45.

Theoretical adiabatic values based upon organic monomer present in polymer.

TABLE 27 ADIABATIC COMBUSTION (FLAME) TEMPERATURES OF METALS AND NONMETALS IN OXYGEN AT 1 ATMOSPHERE PRESSURE*

Substance	Adiabatic Flame Temperature		Substance	Adiabatic Flame Temperature	
	°C	°F		°C	°F
Aluminum	3527	6380	Magnesium	3077	5570
Antimony	1427	2600	Manganese	3127	5660
Barium	2227	4040	Molybdenum	2727	4940
Beryllium	4027	7280	Potassium	1427	2600
Bismuth	1727	3140	Silicon	2227	4040
Boron	2627	4760	Sodium	1727	3140
Cadmium	1427	2600	Strontium	3227	5840
Calcium	3527	6380	Thorium	4427	8000
Iron	2727	4940	Tin	2427	4400
Lead	1527	2780	Titanium	3027	5480
Lithium	2327	4220	Zinc	1927	3500
			Zirconium	4527	8180

* Reference 31

The flame or burning temperatures of cigarettes, matches, and lighters are of practical interest since they can be the source of ignition. Such data are given in Table 28 (Ref. 46) and represent typical values that are associated with diffusion-type burning, as opposed to the more ideal premixed type of combustion. Note that the cigarette temperatures are noticeably increased when exposed to an air draft.

Incendiaries and solid propellant systems of high energy will have combustion temperatures of about 4000-5000°F or more.

TABLE 28 TYPICAL BURNING TEMPERATURES FOR CIGARETTES, MATCHES, AND LIGHTERS*

Material	Condition	Burning Temperature	
		°F	°C
Cigarette, center	No draft	1050	565
Cigarette, center	Draft	1350	732
Cigarette, center	Insulated	1150	621
Cigarette, surface	No draft	550	288
Cigarette, surface	Draft	800	427
Paper match	No draft	1508	820
Wood match	No draft	1346	730
Cigarette lighter	No draft	1200-1500	649-816

* Reference 46

C. HEAT DAMAGE CRITERIA

1. Temperature Criteria

It is well recognized that few materials can withstand the flame temperatures of a large fully-developed fire of hydrocarbon combustibles and other organic or inorganic combustibles. Of great practical interest to the aircraft accident investigator in developing a fire scenario is the extent of damage to materials due to exposure to excessive temperatures or thermal radiation. The extent of fire damage will be largely determined by the fire loading on the material and its massiveness or fineness, meltability, and combustibility.

On the low temperature scale are most textiles or fiber materials (Table 29, Ref. 47). Excluding asbestos and glass fibers, it is apparent that the various listed textiles will melt, soften, or decompose at temperatures as low as about 250°F (121°C) and as high as 500°F (260°C). In deep-seated fires with many layers of these materials, one can usually expect to find molten or charred remnants because of incomplete combustion due to insufficient oxygen (or air) within the burning pile. Other relatively low temperature limits are summarized in Table 30.

TABLE 29 TEMPERATURE LIMITS OF VARIOUS TEXTILES*

Fiber	Temperature °F	Fiber	Temperature °F
Acetate	500; melts	Polyester	480; melts
Asbestos	1490; NS	Polyethylene	240; melts**
Cotton	300; decomposes	Polypropylene	330; melts**
Flax	275; NS	Silk	300; decomposes
Glass	1350; softens	Viscose Rayon	350-400; decomposes
Jute	275; NS	Wool	275; decomposes
Nylon 6	420; melts**		

* Reference 47

** Spread of values $\pm 10^\circ\text{F}$

NS - Not specifically defined but indicative of thermal degradation.

**TABLE 30 TEMPERATURE LIMITS OF PLASTIC,
 RUBBER, AND OTHER MATERIALS***

Material	Temperature (°F)	Material	Temperature (°F)
Aircraft Paints	400, softens 800-850, blisters	Paper/phenolic Plastic vinyl chloride Polystyrene	250, distorts 185, distorts 210, distorts
Cellulose (filled melamine)	400, distorts		
Melamine/formaldehyde	266-400, distorts	Silicone rubber	425, softens
Methyl methacrylate	210, softens		700, blisters
Neoprene rubber	500, blisters	Styrene elastomer	220, distorts
Nylon (polyamide)	300-360, distorts		
Nylon spaghetti	250-350, melts		

* References 1 and 4.

On the high temperature scale (>1000°F) are such noncombustibles as asbestos, glass, and other refractory materials and most metal materials, which generally have high melting points. Melting points for metal and nonmetal materials are given in Table 31 and for the pure elements in Table 12. Note that aluminum and magnesium alloys have low melting points (1000-1200°F) compared to those of steel, titanium, or other constructional metal materials. Among the lowest melting point metals are bismuth, lead, cadmium, and tin, some of which are used in solders that melt below 300°F.

Where any combustible solid is exposed to fire, those with the lowest autoignition temperatures (AIT's) will suffer the greatest damage if they are in a sufficiently divided form to permit ignition. The AIT and other ignition temperature data that are summarized under "Properties of Aircraft Combustible Solids" define the combustible threshold temperatures with different heat sources in air and oxygen atmospheres. In a fire situation, the combustion temperatures of the solids may be as high as their adiabatic flame temperatures that are summarized in the above section of this report; however, adiabatic conditions are rarely achieved.

The color or discoloration temperatures of metals can also be useful in this connection. Table 32 (Ref. 47) lists the color temperatures of iron or steel when heated to the given temperatures. Other guidelines are as follows (Ref. 50):

TABLE 31 MELTING POINTS OF METAL AND NONMETAL SUBSTANCES*

Substance	Melting Point °F	Substance	Melting Point °F
Metals			
Aluminum alloy 38	1050	Cupronickel, constantan	2300
Aluminum alloy 3003	1200	Hastelloy C	2350
Aluminum bronze, ASTM-B36	1900	Inconel X, annealed	2550
Bismuth solder	< 265	Magnesium alloy, AZ3113	1160
Carbon steel, SAE 1020	2750	Monel K	2430
Cast iron, gray, ASTM-A48	2150	Nickel-silver alloy, 18%	2030
Cast iron, ductile, ASTM-A339	2100	Stainless steel, type 304	2600
Brass, red, ASTM-B30	1820	Tin solder	< 350
Brass, yellow, ASTM-B36	1710	Titanium, commercial	3300
Nonmetals			
Borax	1040	Paraffin	129
Enamel colors	1760	Porcelain	2820
Glass, borosilicate	1510**	Quartz, clear	3020**
Graphite	6700	Spermaceti (wax)	120
India rubber	257	Stearine (wax)	122

* References 47, 48, and 49; rounded values.

** Softening point

TABLE 32 COLOR TEMPERATURES OF IRON OR STEEL*

Metal Color	Temperature °F	Metal Color	Temperature °F
Dark blood red, black red	990	Orange	1650
Dark red, blood red	1050	Light orange	1725
Dark cherry red	1175	Yellow	1825
Medium cherry red	1250	Light yellow	1975
Cherry, full red	1375	White	2220
Light cherry, light red	1550		

* Reference 47.

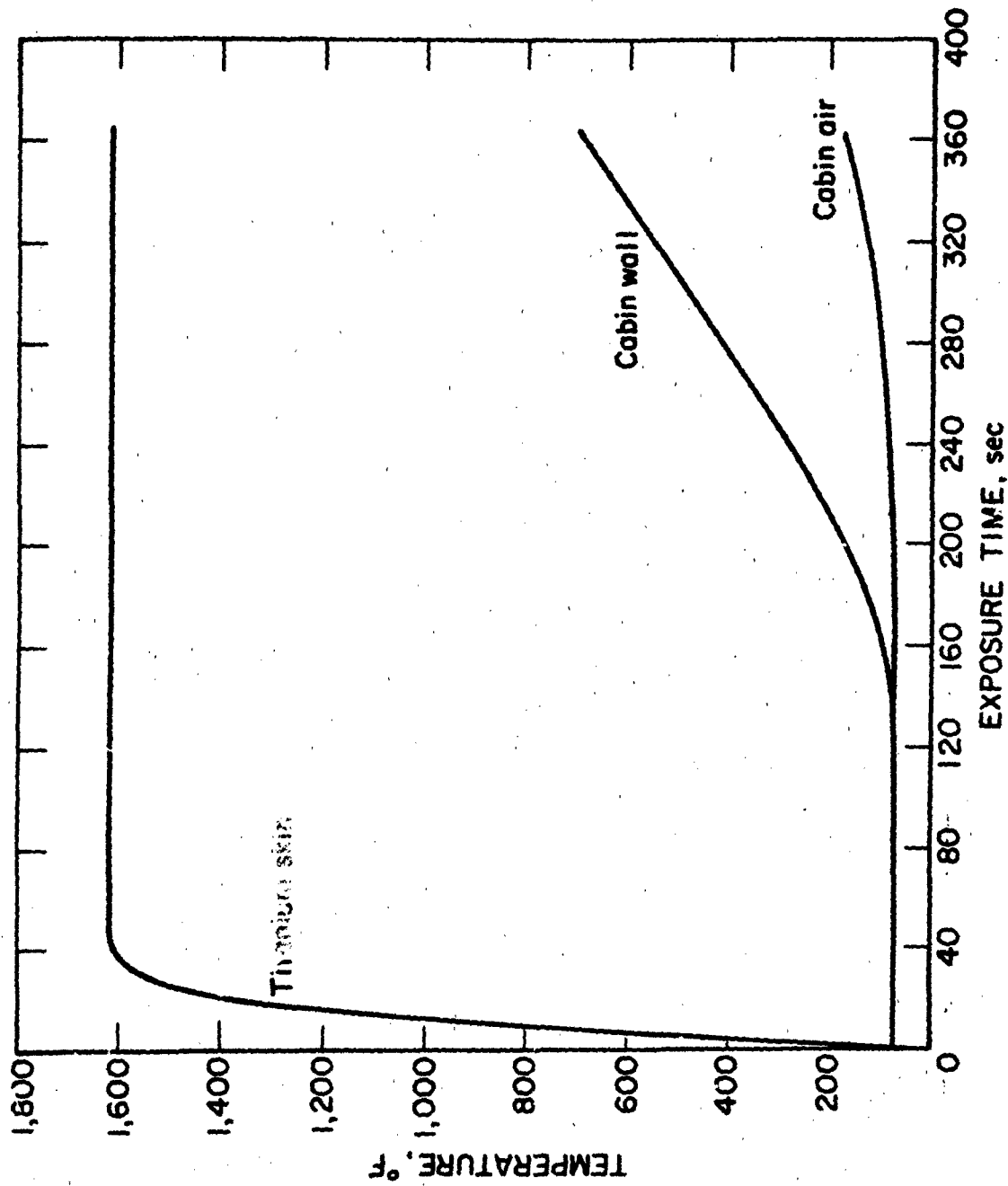

Figure 32. Predicted Temperature History of a Titanium Fuselage Adjacent to a Severe External JP-4 Jet Fuel Fire

Aircraft Paint	- Discolors at 600°F
Aluminum	- Becomes plastic and sags at about 800°F and melts completely at about 1200°F
Stainless Steel	- Discolors at 800-900°F; tan to light blue, to bright blue, and to black with increasing temperature
Titanium	- Discolors at 700°F; tan (gray or beige) to light blue at 900°F, to dark blue, and to tan with increasing temperature; yellow shade and oxide scale around 1200-1500°F.
Zinc Chromate Paint Primer	- Discolors at 450°F; tan to brown at 500°F and to black at 700°F.
Cadmium	- Discolors at 500°F.

In applying these data, it must be realized that the metal discolorations are a function of time and temperature. For example, the exposure of titanium at 700°F for several hours may produce the same discoloration as that resulting from an exposure at 1000°F for only several minutes.

A typical temperature or heat loading on an aircraft from a severe external jet fuel fire is illustrated by Figure 32 (Ref. 51) in which a sealed titanium fuselage was used. The aircraft skin temperature becomes maximum (~1600°F) within one minute, whereas the cabin wall and air temperatures remain normal for at least two minutes or more; also, the titanium did not fail. In comparison, an aluminum fuselage would begin to fail within about one minute because of its low melting point (~1100-1200°F). These data also indicate possible safe egress times after a survivable crash fire accident, providing the cabin atmosphere is not lethally toxic or asphyxiating and the external fire does not envelop all escape routes. The possibility of an explosion of fuel vapors in any confined spaces of the aircraft will exist even in post-crash fires; possible areas include engine bays, fuel tanks (vented), and any vented aircraft compartment where fuel vapors may be ingested.

The failure times of some aircraft materials exposed to a 2000°F fire are given in Table 33 (Air Force data). At such high temperature, the failure times are of the order of seconds for thin aluminum panels, empty aluminum lines, and electrical insulation (800°F pyrolysis) but several minutes for filled aluminum fluid lines because of the heat sink provided by the fluid. Important factors are thickness, melting or softening points, ease of decomposition or combustion; high air flow (e.g., >1000 ft./min.) can provide cooling and increase the failure times noticeably.

TABLE 33 FAILURE TIMES FOR COMPONENTS EXPOSED TO A 2000°F FIRE

Material	Failure Time
Thin skin aluminum panels	<30 sec.
Empty aluminum lines	<60 sec.
Pressurized aluminum fluid line (no flow)	< 5 min.
Pressurized aluminum fluid line (flow)	> 5 min.
Electrical wiring harnesses (800°F pyrolysis insulation)	<15 sec.

2. Radiation Criteria

Thermal radiation of a fire can also cause property damage and human injury. The threshold radiation intensities required for igniting various combustible solids and for sensing pain by humans are given in Table 34 (Ref. 35). Important here is that such materials as wood and textiles can ignite at a heat flux of $<1.0 \text{ cal/cm}^2\text{-sec.}$ ($3.69 \text{ btu/ft.}^2\text{-sec.}$) and humans feel pain (2nd degree burns) at $0.1 \text{ cal/cm}^2\text{-sec.}$ Radiant ignition energies for other combustible solids have been previously summarized in Table 14.

The fire radiation received by an object will depend upon its distance from the fire source and the size and intensity of the fire source. Figure 33 (Ref. 52) shows such data where the irradiance (I) of gasoline tank fires is plotted as a function of the irradiance distance and radius of the burning fuel tank (x_0/r_0); original data have been replotted and show wood ignition requirements as a reference point, assuming a conservative value of $0.5 \text{ cal/cm}^2\text{-sec.}$ ($1.85 \text{ btu/ft.}^2\text{-sec.}$) for wood. Radius (r_0) of the fuel tank can be assumed to be equivalent to radius of the pool fire. Thus, if radiant ignition energies are known, as in Tables 14 and 34, Figure 33 can be used to roughly estimate the separation distances for ignition by an aircraft fuel fire.

TABLE 34 THRESHOLD (MINIMUM) RADIATION INTENSITIES FOR VARIOUS EFFECTS*

Effect	Thermal Radiation Intensity	
	cal/cm ² -sec.	Btu/ft. ² -sec.
Wood ignites spontaneously	0.8	2.94
Hemp, jute, and flax ignite spontaneously	1.0	3.69
Textiles ignite spontaneously	0.85	3.14
Fibre board ignite spontaneously	0.75	2.78
Wood ignites by flying brands	0.1	0.37
Painted wood ignites by flying brands	0.4	1.47
Humans feel pain after a short time	0.1	0.37

* Reference 35

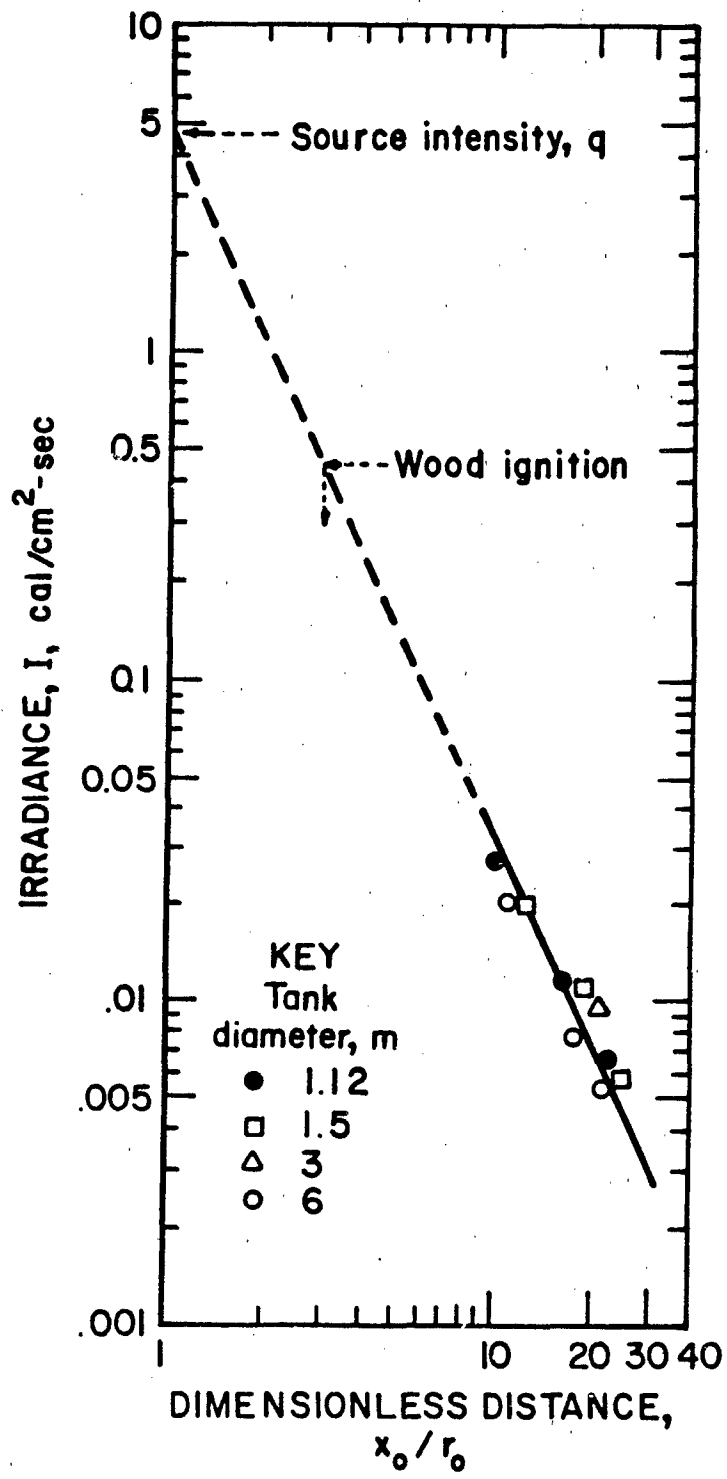

Figure 33. Thermal Irradiance of Gasoline Tank Fires as a Function of a Dimensionless Distance Ratio (Irradiance Distance/Tank Fire Radius)

The maximum thermal irradiance at the surface of a large pool fire is at least 40 kilowatts per square foot (1 kw/ft² = 0.95 Btu/ft.²-sec. or 0.257 cal/cm²-sec.) for most liquid hydrocarbon fuels. As indicated in Table 35 (Ref. 28), the radiative output is about 1/3 or less of the total available thermal output, depending upon the fuel. Assuming spherical symmetry and a flame point source, the radiant heat flux (h_x) at various distances (x) from a burning pool of radius (r) may be calculated as follows:

$$h_x \text{ (kw/ft.}^2\text{)} = \frac{h_r \pi r^2}{4 \pi x^2} \quad (40)$$

where h_r can be taken from Table 35 for the fuel of interest. Note that Figure 33 also is consistent with the inverse square dependence with distance from the fire source. By equation 40 and Table 35, a gasoline pool fire of 5-foot radius should yield a radiant heat flux at a 50-foot distance as follows:

$$h_x = \frac{72 \pi (5)^2}{4 \pi (50)^2} = 0.18 \text{ kw/ft.}^2 \text{ (0.046 cal/cm}^2\text{-sec.)}$$

This value compares favorably with the value of 0.035 cal/cm²-sec. indicated in Figure 33 at an x₀/r₀ of 10; excellent agreement is obtained if the h_r value from very large scale tests (58 kw/ft.²) is used in equation 40. In any case, the above spherical model should provide a minimum estimate of the actual irradiance since the assumption of a hemispherical pool fire model would yield twice the values predicted by Equation 40.

Where fire resistant materials are exposed to fire, their ignition and heat release will tend to vary with the incident heat flux. Figure 34 (Ref. 53) shows such information for epoxy, phenolic, polyimide, and bismaleimide resin materials that may be used in aircraft interior panels; incident heat fluxes of 2.5 and 5.0 watts/cm² (0.6 and 1.2 cal/cm²-sec.) were used. The oxygen index (O₂/O₂ + N₂, vol. %) is also included and defines oxygen requirement for downward flame propagation (ASTM-D2863).

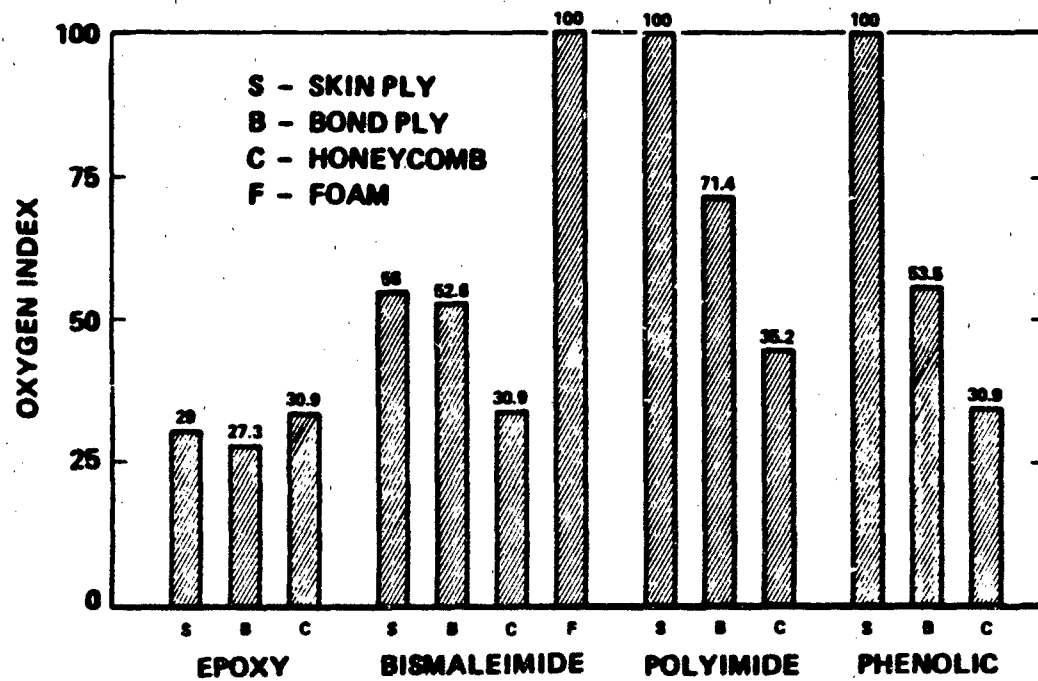
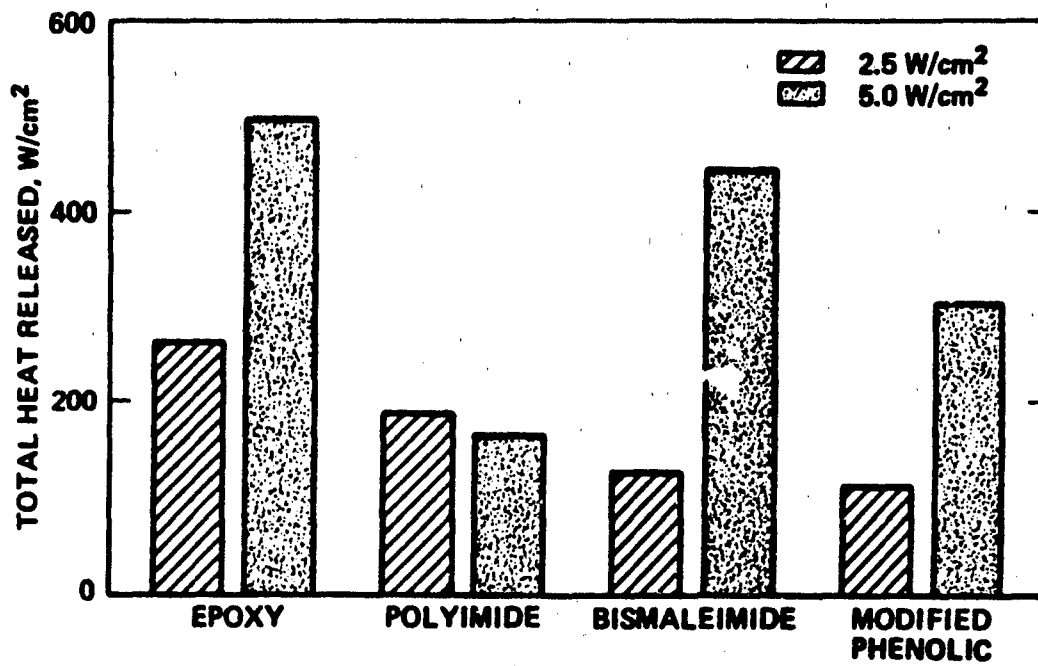

Figure 34. Heat Release and Oxygen Index of Composite Constituents for Use in Aircraft Interior Panels

**TABLE 35 SUMMARY OF COMPUTED VALUES BEARING
 ON RADIATIVE HAZARDS OF FIRES***

Fuel	Linear Burning Rate (large diameter) in/min.	Thermal Output per unit liquid surface			
		Total kw/ft. ²	Radiated kw/ft. ²	Radiated cal/cm ² -sec.	Radiated %
Butane	0.31	140	38	9.8	27
Hexane	0.29	140	54	13.9	38.5
Benzene	0.24	140	49	12.6	35
Xylene	0.23	135	-	-	-
Methanol	0.067	17	3	0.8	17.5
Hydrogen**	0.55	75	19	4.9	25
UDMH	0.15	59	16	4.1	27
LNG	0.26	86	20	5.1	23
Gasoline	0.22	-	72	18.5	27

* Reference 28
 ** Uncertain data

NOTE: 1 kw/ft.² = 0.257 cal/cm²-sec.

In a survivable crash fire accident, the chance of human survival is greatly reduced when a massive fuel spillage and subsequent ignition occur. Figure 35 (Ref. 1) shows that the fireball hazard in vertical drops with JP-4 and JP-8 (liquid or emulsified) can be great even with only five gallons of dispersed fuel. Particularly important is that the fireball hazard becomes nearly comparable for the low and high flash point liquid fuels if the impact velocity is increased sufficiently (e.g., ≥60 mph). The maximum radiative output was about 1/3 of the total thermal output for these liquid fuels and consistent with the data of Table 35 for hydrocarbon fuels.

Very large fireballs may also result from a "Bleve," a boiling liquid - expanding vapor explosion. Usually such explosions occur when a tank of liquefied petroleum gas or high volatility fuel is excessively heated by an external fire and ruptures at relatively high pressures. The fireball diameter may be estimated by the following expression (Ref. 54):

$$d = 3.86 W^{1/3} \tag{41}$$

where d is fireball diameter in meters and W is fuel weight in kilograms.

D. FIRE DAMAGE PATTERNS

Damage patterns in aircraft fires will depend upon the nature of the fire source (size, intensity, duration), properties of the aircraft materials (combustibility, thermal stability, etc.) and their proximity to the fire source, and the flight or environmental conditions associated with the accident. Material damage will typically include the following:

1. Softening or melting of metals, plastics, rubbers, etc.
2. Discoloring, scorching, or eroding of metal and nonmetal surfaces

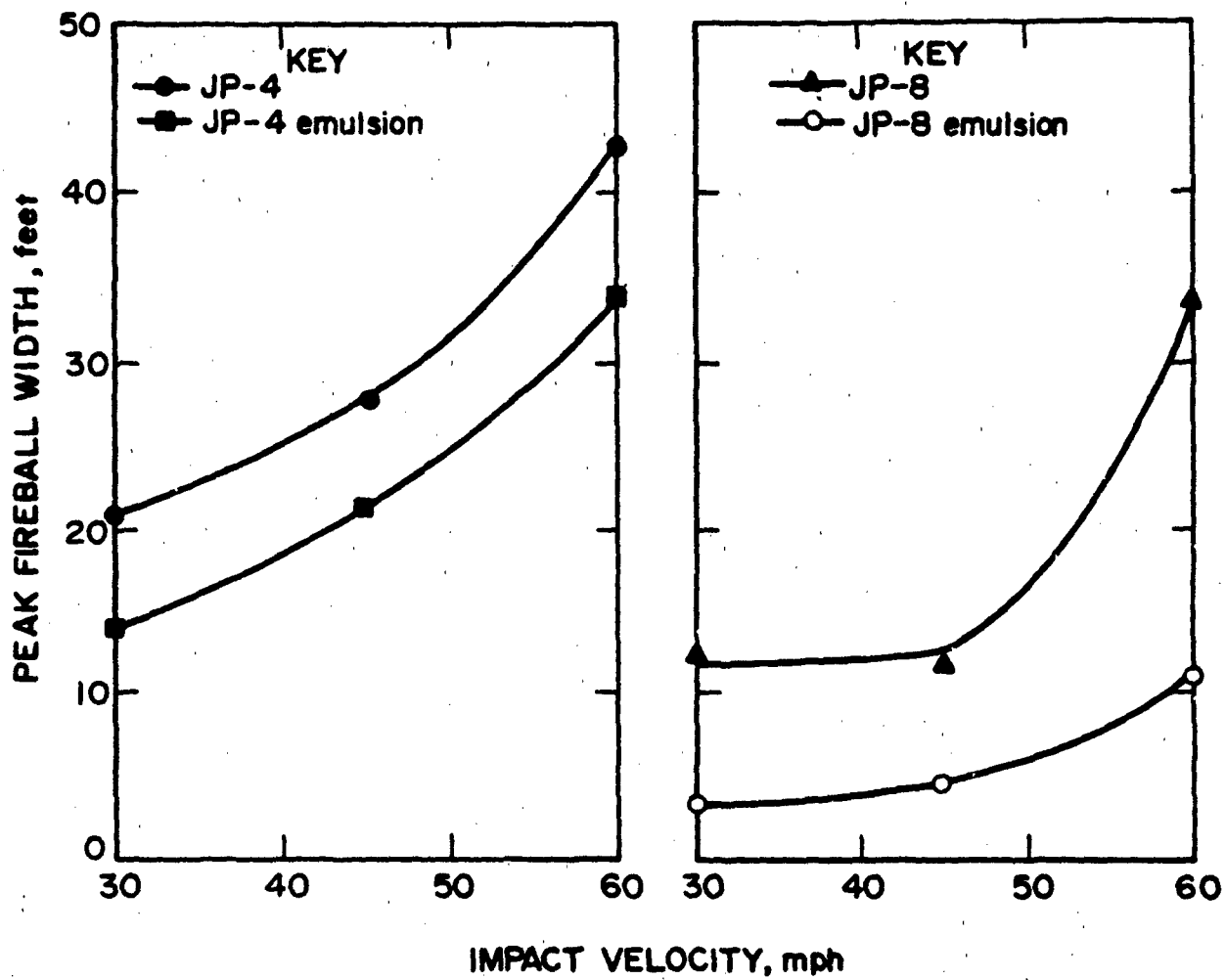

Figure 35. Variation of Peak Fireball Width with Impact Velocity for Vertical Drops with Five-Gallon Metal Containers

3. Charring of combustible organic solids
4. Consuming of combustible materials
5. Forming of soot or other combustion products

Many data have already been summarized for predicting or confirming the critical temperatures or heat fluxes at which aircraft materials may produce such fire effects. Some additional guidelines are described herein.

1. Ground Aircraft Fires

In a crash-type ground accident, the fire damage pattern will vary with the angle of impact. At a steep angle of impact (Figure 4), a large fireball of intense burning and short duration will usually result at the instant the aircraft disintegrates, causing ignition of widely dispersed fuel from ruptured fuel tanks; frictional impact alone can produce such ignitions. Fire damage to scattered aircraft components will be greatest for those within the ground fire area extending from the crater or point of impact; duration of the ground fire can be several minutes or more.

At a shallow angle of impact (Figure 3), the fire damage can extend over a large area or flight path before impact, depending upon when any fuel tanks rupture and ignition results. If an in-flight fire occurs before impact, molten metal droplets or burned parts of aircraft materials may be found along the flight path. In all crash-type accidents, the fire damage will be diminished if the materials become enveloped or shielded by water, dirt, or other noncombustibles. Also, any leaves, twigs, etc. may be outlined in the soot patterns.

Ground fires of parked or taxiing aircraft usually result from the leakage or spillage of fuels (or flammable fluids) that are ignited by some electrical or hot surface ignition source. The high volatility jet fuels generally will produce the more widespread fire damage because of their high flame spread rates. Light constructional materials can display severe thermal damage, depending upon the duration of fire exposure and the wind conditions; fire temperatures will typically be less than 2000°F without air ventilation and of the order of 3000°F with high ventilation rates (high wind conditions). Burning and soot patterns will be sporadic but tend to be mostly in the upward direction because of buoyancy or chimney effects.

Highly localized damage, such as substantial melting or burning of titanium and stainless steel materials, can be considered indicative of oxygen-enriched fires or high energy fuel-oxidant systems. The damage can be similar to that obtained with an oxygen welding torch. High velocity sprays from partially ruptured fuel, oil, or hydraulic fluid lines can produce intense fire damage but not as severe as that associated with the rupture of high pressure oxygen bottles. The rupture of hot bleed-air lines can also enhance burning in an aircraft fire, although here again the damage will not compare to that possible in pure oxygen; however, hot bleed-air lines (e.g., ~900°F) do present an ignition hazard with low AIT combustibles.

Ground fires of large quantities of fuel (e.g., large fuel spill) in still air will generally be fuel-rich and form considerable black soot. Those areas which show the greatest fire intensity may contain little soot since combustion will be more complete; also, soot is unlikely to attach itself to surfaces heated over ~700°F (Ref. 4). If the soot pattern across material failures

shows no continuity, one may assume the soot pattern was formed after the aircraft disintegrated (see also next section).

Loose fuel or fluid line connections (e.g., "B" nuts) do not necessarily indicate that a leakage occurred before the fire. Loose "B" nuts may be caused either by mechanical damage or fire. As a rule of thumb, if a "B" nut is more than a quarter of a turn loose, it is not the result of fire.

2. In-Flight Aircraft Fires

As noted previously, when an aircraft crashes, an impact explosion and sustained ground fire are expected. These type reactions must be understood in order to determine if a fire occurred prior to impact. If an in-flight fire occurred, the probable cause must be investigated. If evidence of an in-flight fire is not established, either there was no in-flight fire or the evidence was masked by the impact/ground reaction. In this case, the cause of the mishap may be in another discipline; however, the fire pattern investigation must be able to support either conclusion related to an in-flight fire.

In-flight fires may have temperatures over 3000°F because of the rapid and turbulent burning that is possible at high air velocities or ventilation rates. Even the high temperature metals may erode or at least melt under such severe conditions. The fire damage pattern will tend to follow the direction of the air flow (or slipstream) as illustrated in Figure 36 for an external in-flight fire. The attached flames in these fires will ordinarily burn through the aircraft surfaces and produce more melting and bubbling material than in a ground fire. Any near-molten aluminum which is subjected to a shock loading (e.g., impact) can have a "broomstraw" or "feather" appearance similar to that shown in Figure 37.

Broomstraw is evidence that an in-flight fire may have existed prior to impact. If it can be shown that the structural component with the broomstraw could not have been hot for any reason other than a fire and that the broomstraw did not occur due to a secondary ground fire and explosion, then a strong case to support an in-flight fire can be documented.

Soot from in-flight fires travels downstream of the fire source and attaches itself to aircraft surfaces by electrostatic attraction and adhesion properties of the "oily" soot. A continuous or detectable soot pattern, as in Figure 38, in the direction of airflow is indicative of an in-flight fire; a tail in the pattern is a good clue of the flow direction. The shapes of the patterns will be affected by any object (e.g., rivet) that disturbs the airstream or shrouds a surface from soot depositions (Figure 39). For example, a soot area immediately downstream of a rivet may have a tail which indicates the airstream pattern. The discoloration pattern from a flame in the airstream will also display this effect.

Soot or burn patterns on aircraft surfaces may be broken by mechanical damage (Figure 40), as in a crash accident after an in-flight fire. A typical example is where soot is found on the top or bottom surfaces of the fractured material but the fractured edges are free of any combustion evidence (Figure 41). This evidence indicates the fire damage (soot formation) occurred prior to the mechanical damage. If, however, the fractured edges also contain soot (Figure 42), two possibilities exist: (1) fire damage to the main material surfaces occurred prior to the mechanical damage and soot on the edges

EXTERNAL FIRE IN-FLIGHT



ATTACHED

- CONTINUOUS REIGNITION FROM FIRE WITHIN AIRCRAFT
- INCREASING A/C VELOCITY MAY NOT CAUSE BLOW-OUT
- WILL CAUSE THERMAL DAMAGE TO AIRCRAFT

TRAILING AIRCRAFT

- CONTINUOUS REIGNITION IN LOW VELOCITY RECIRCULATION ZONE
- INCREASING A/C VELOCITY MAY CAUSE BLOW-OUT
- MAY CAUSE LITTLE OR NO DAMAGE TO AIRCRAFT

Figure 36. Aircraft Fire Pattern for an External In-Flight Fire



Figure 37. "Broomstraw" Evidence on Damaged Aluminum Metal Strip

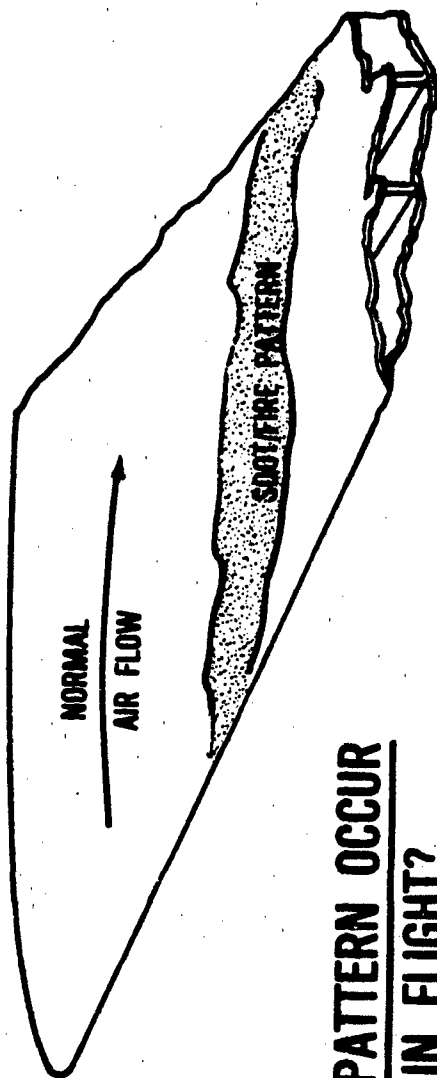

**DID PATTERN OCCUR
IN FLIGHT?**

- RELATE PATTERN TO AIR FLOW
INSPECT OTHER AIRCRAFT
- WHERE WAS SOURCE FOR PATTERN??
- DEVELOP SCENARIO TO EXPLAIN

Figure 38. Soot/Fire Pattern Relative to Air Flow

EVIDENCE:

- SOOT OR DISCOLORATION PATTERN ACROSS RIVET HEADS, SPLICES, ETC

LOOK FOR TAIL IN PATTERN



FACTORS:

TEMPERATURE OF SURFACE

TEMPERATURE OF GAS

FLOW DIRECTION MAY CHANGE

REYNOLDS NUMBER

AMOUNT OF SOOT IN GAS

CONCLUSION:

A TAIL IN PATTERN IS BEST INDICATION OF FLOW DIRECTION

Figure 39. Analysis of Evidence on Soot or Discoloration Patterns of Aircraft Materials in In-Flight Fires

EVIDENCE:
MECHANICAL DAMAGE REMOVES SOOT

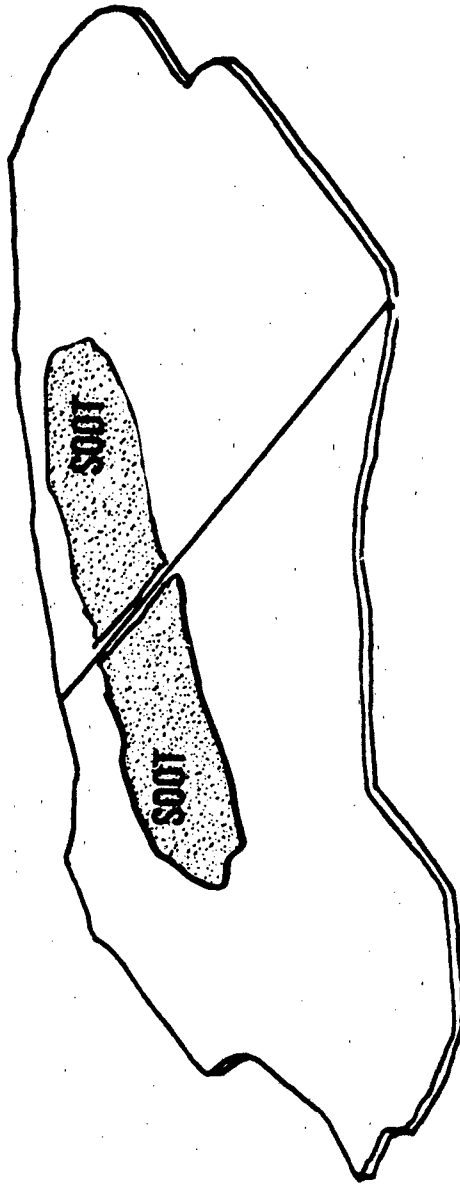

CONCLUSION:
**MECHANICAL DAMAGE AFTER SOOT
INFLIGHT VS GROUND FIRE SOURCE OF SOOT??**

- EXTERNAL SURFACE
- INTERNAL SURFACE

**INSPECT EDGES
SOURCE OF SOOT**

Figure 40. Analysis of Mechanical Damage of Soot Pattern

EVIDENCE:
**BURN PATTERN ACROSS TWO
MATING SPECIMENS**



CONCLUSIONS:
**IF FRACTURED EDGES CLEAN AND MATE,
THEN FIRE DAMAGE PRIOR TO BREAK**
NOTE: BREAK COULD HAVE OCCURED

- IN FLIGHT
- INITIAL GROUND IMPACT
- SECONDARY GROUND IMPACT

Figure 41. Analysis of Evidence on Soot or Combustion Patterns of Fractured Aircraft Materials

EVIDENCE:

- BURN PATTERN UNIFORM ACROSS AND INTO FOLD
- FRACTURED EDGES CONTAIN SOOT DEPOSITS

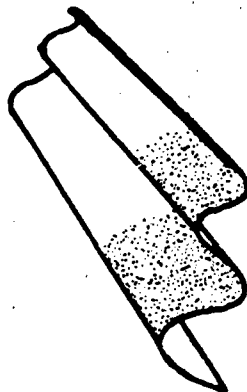

CONCLUSIONS:

- FIRE DAMAGE IN SPECIMEN FOLD OCCURRED PRIOR TO MECHANICAL DAMAGE
- SPECIMEN MAY HAVE BEEN THROWN (PROPELLED) THROUGH IMPACT FIRE BALL CAUSING SOOT ON EDGES
 - LOOK FOR SOOT ON ALL SURFACES – ADDITIONAL MECHANICAL DAMAGE CAN OCCUR ON SECOND IMPACT
- AND/OR SPECIMEN MAY BE EXPOSED TO GROUND FIRE
 - RELATE SOOT PATTERN WITH GROUND PROTECTED SURFACES – CAUTION: SPECIMEN MAY HAVE BEEN MOVED

Figure 42. Analysis of Evidence on Soot or Combustion Patterns in Folds of Fractured Aircraft Materials

resulted from exposure to a subsequent fire (e.g., in-flight or crash fire); (2) fire damage to both surfaces and edges occurred after the mechanical damage (e.g., crash fire alone). In the case of ruptured closed containers (e.g., fuel tanks), one should also expect soot on the fractured edges as a result of fire after the rupture (Figure 43).

Both top and bottom surfaces of materials should be examined to determine the fire damage patterns. Bright scratch marks, scuffs, and smears in the soot/discoloration pattern can be indicative of mechanical damage from fragmented aircraft components after the combustion event. The normal soot formation that can occur in the aft compartments of military aircraft, especially during taxiing or ground operations, should not be confused with mishap fire damage evidence.

3. Electrical and Powered Systems

Fire damage of electrical systems can be considered attributable to an external fire source or an internal electrical source. An external fire will burn inward through the insulation and normally results in damage that is largely dependent upon the temperature limitations of the materials comprising the electrical wiring or equipment. A copper wire bundle exposed to a hydrocarbon fuel fire may oxidize or melt, depending upon the fire temperature. The oxidation or discoloration of wires due to heat will be minimal for the buried strands of a wire bundle when exposed to an external fire.

Where the heat source is purely electrical, as with excessive current, the wire discoloration and deterioration may be evidenced throughout the length of the affected wire; other wires of the bundle may show little or no damage. The failure of such electrical circuits can produce electrical arcs that are characteristic of highly localized and severe fire damage. In such cases, the fire damage is indicated by melted globules on the ends of the wire strands, weldings of the strands, or by smoothly rounded strand ends (Figure 44, Ref. 5).

A search of similar type damage should be made in examining the wiring, brushes, commutators, and field armature windings of electric motors. Circuit malfunctions can also be determined from an examination of fuses, circuit breakers, and relays or solenoids; word of caution - fuses and current limiters may conceivably suffer little damage if the electrical fault is removed very rapidly. The equipment should be examined for overheating, burning, arcing, faulty connections, and open or shorted circuits. Wire chafing damage will be evidenced by loss of wire insulation and possible erosion or melting of metal surfaces due to any arcing.

Damage to light bulbs, especially warning lights, can be useful in determining what electrical systems were under power at the time of the accident. If the bulb filament coil is broken or unbroken and essentially clean, bright, and unstretched, the damage occurred while the filament was cold, i.e., without power. However, if the filament coil shows evidence of severe stretching or melted globules are found on any broken ends, this damage occurred while the filament was illuminated. In a crash accident, the shock loading will cause little filament stretching with an unlit bulb but severe stretching with an illuminated one (Figure 45, Ref. 5). A hot filament will be consumed or oxidized upon failure of the bulb's glass envelope.

EVIDENCE:

FIRE DAMAGE ON BOTH INSIDE AND OUTSIDE SURFACE

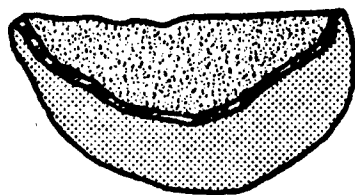

CONCLUSION:

- IF CLOSED CONTAINER
FIRE AFTER DAMAGE - EDGES SHOULD HAVE SOOT
- IF OPEN SPECIMEN
INSPECT EDGES

NOTE: THERE COULD HAVE BEEN TWO FIRE EXPLOSURES

Figure 43. Analysis of Fire Damage to Open and Closed Containers

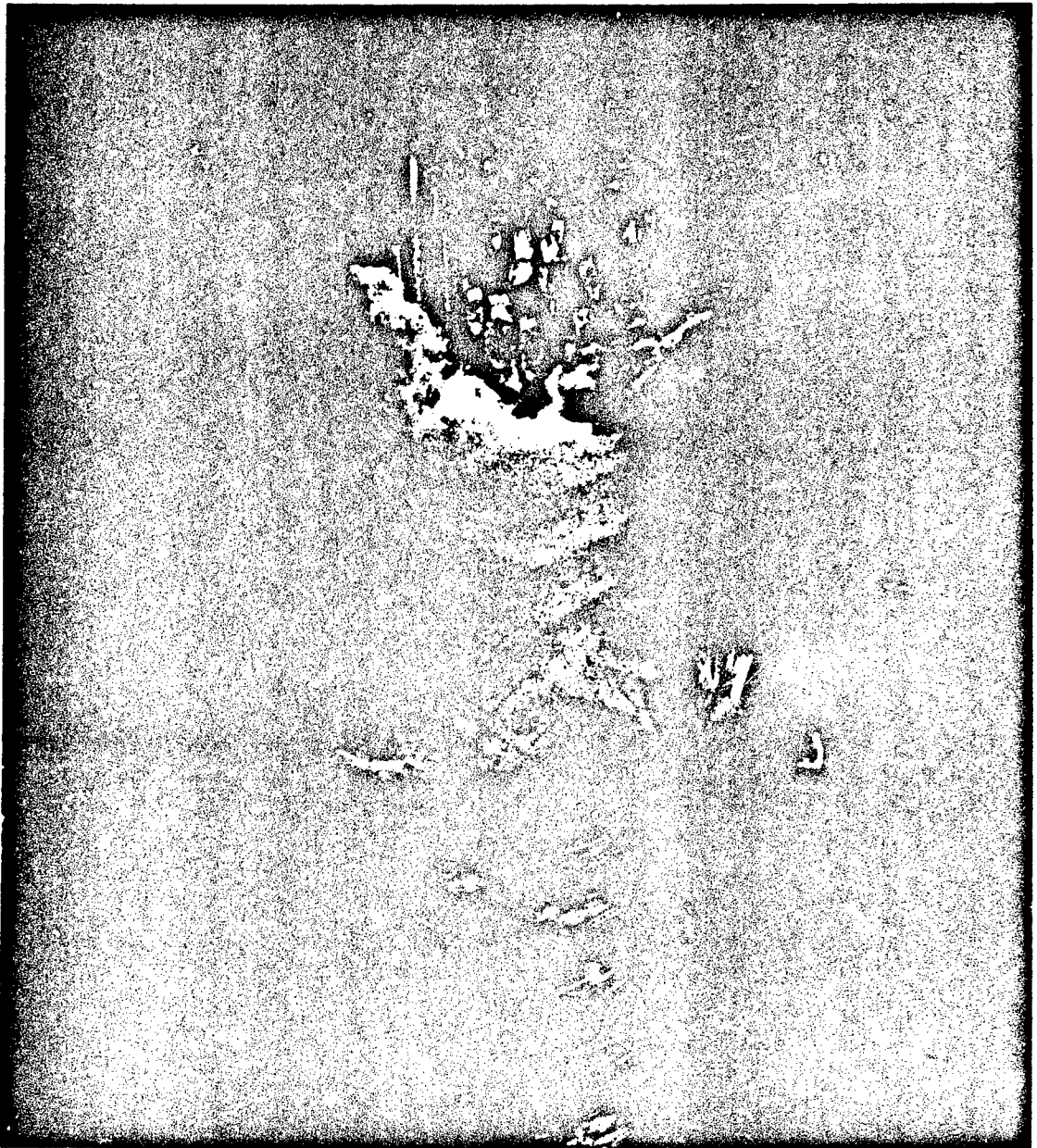

Figure 44. Power Feed Cable Cut by Propeller Blade when Electric Power was Present. Note Smoothly Rounded Strands Resulting from Melting.



Figure 45. Warning Light Bulb with Envelope Intact Showing Stretching of Filament. Indicates Bulb was Illuminated at the Time of Receiving Physical Shock during Accident.

The damage to powered equipment such as pumps and compressors may be associated with the cause of the accident or the effect of the fire, explosion, or crash. If the equipment is exposed solely to fire, the fire damage will be determined largely by the fire temperatures and temperature limitations of the equipment materials. However, if the equipment is under power during the fire, loss of lubricant or poor lubrication will occur and may result in bearing seizures and mechanical damage to the driven components; the lubricant seals may show both fire and mechanical damage in the severe cases.

If the equipment is involved in a crash accident, the nature of the damage to impeller or rotating sections of the equipment can indicate whether the equipment was powered or not (Figure 46); both rotating and stationary (e.g., motor casing) parts need to be examined. The impeller blade damage for equipment under power will tend to be more uniform and circumferential than for equipment under no power at the time of impact. Figure 47 (Ref. 5) shows the damage encountered by jet engine compressors under the two power conditions. The frictional heating from abrading fan blades, seizing bearings, and misaligned drive shafts can be sufficient to melt materials such as aluminum. Bearings are often galled and drive shafts scored or "bleed" in such cases.

4. Summary of Fire Pattern Investigation Factors

As a convenience for quick reference, a listing is made herein of various informative or instructive items for determining the fire pattern of an aircraft mishap. The listing should not be construed to be complete for all possible fire situations. The investigator should modify such listings as may be required for application to different aircraft fire situations:

- (1) Obtain fuel and hydraulic fluid samples for analysis.
- (2) Relate observation and engineering logic to both available and unavailable physical evidence.
- (3) Some parts/components of the aircraft may have been exposed to three different fires/explosions: (a) in-flight, (b) ground impact, and (c) sustained ground. Evidence must be explained in light of the foregoing possibilities.
- (4) Some parts/components may have been moved prior to the investigator's involvement. Consider this in assessing the evidence.
- (5) Fires in internal areas of the aircraft may leave "chimney" effect evidence.
- (6) Look for in-flight fire evidence on parts not subjected to ground fire - could the impact fire ball be the cause?
- (7) In-flight fire may leave less metal residue than ground fire because molten metal deposited downstream.
- (8) Forced convection in-flight fires and impact fire ball may exceed 3000°F.
- (9) Parts subjected to in flight fire may be more severely burned than parts subjected to ground fire.

EVIDENCE:
**MECHANICAL DAMAGE BETWEEN ROTATING
AND MATING NON ROTATING PARTS**

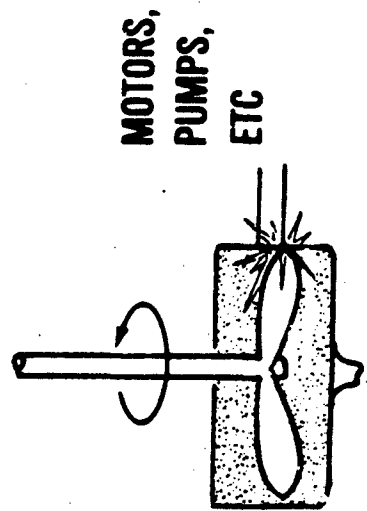

CONCLUSIONS:
**MAY INDICATE COMPONENT ROTATING AT
IMPACT - DEPENDS ON AMOUNT AND
PATTERN OF DAMAGE**

Figure 46. Analysis of Mechanical Damage to Rotating and Nonrotating Parts

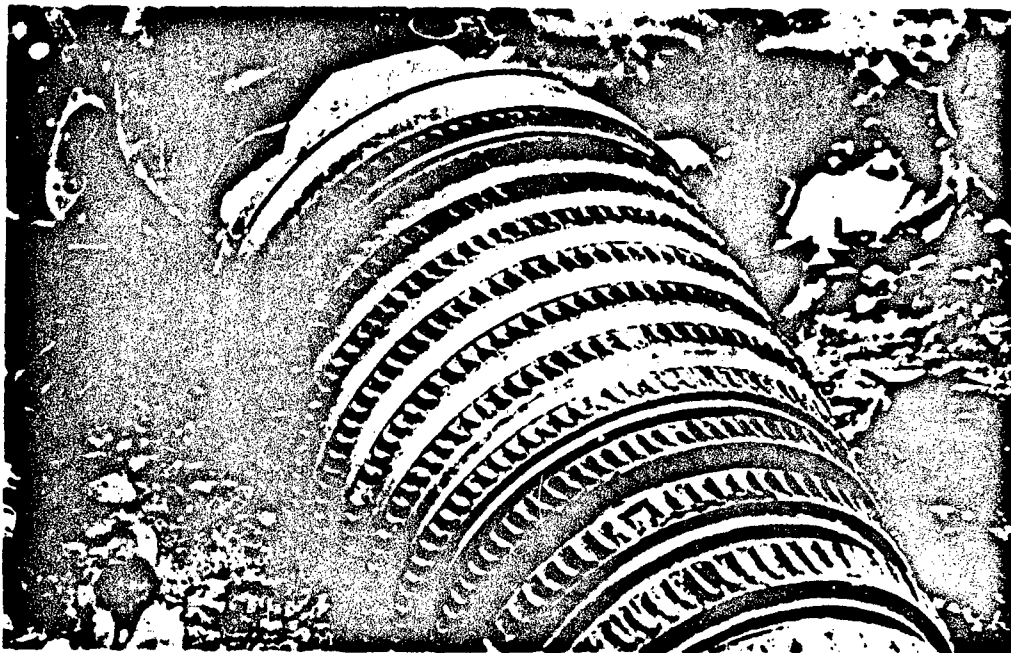

Impact under power.

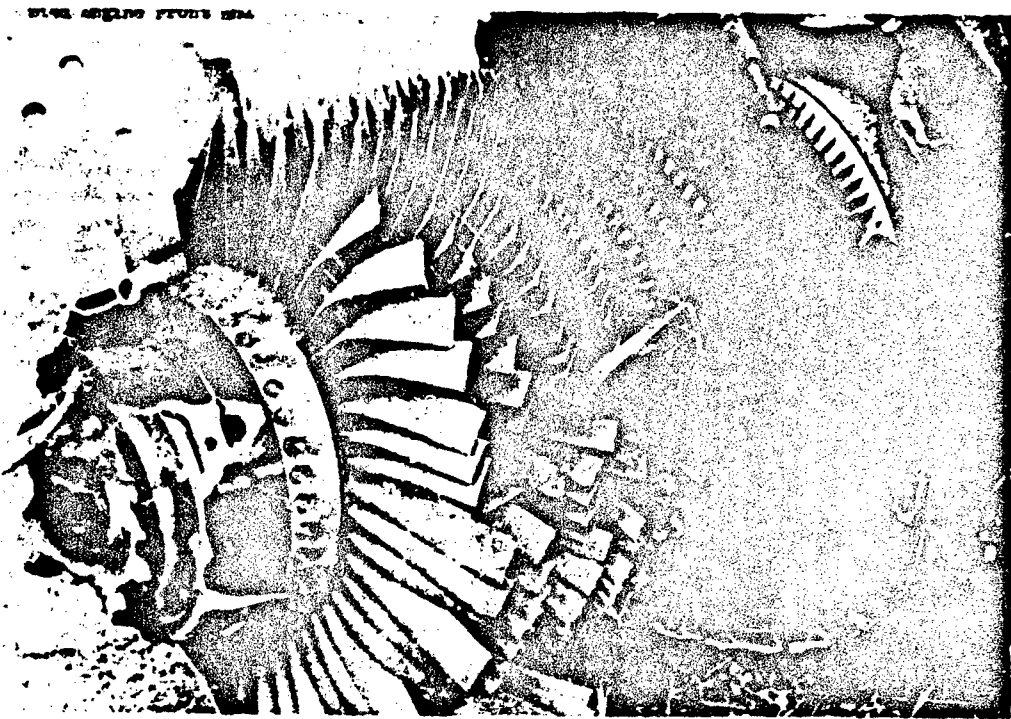

Impact not under power (flame-out).

Figure 47. Damage to Jet Engine Compressors after Impact under Power and Nonpower Conditions

- (10) Unlike most fires in structural buildings, where fire loadings are somewhat static, the original ignition source in aircraft in-flight fires is not necessarily the area where most severe burning is experienced.
- (11) Secondary fires may obscure or mask other evidence.
- (12) Water or dirt covering may protect parts from ground fire.
- (13) Check for residual fuel odors.
- (14) Halon fire extinguishing agents may react with hot components. Lab test may confirm this.
- (15) Field examination of fire-damaged materials will not give total picture. Reconstruction may be necessary.
- (16) Smoke/soot pattern will follow airflow - tail may form downstream from rivets and skin splices.
- (17) Soot and discoloration patterns may be due to normal operations. (Check and compare with other aircraft).
- (18) Bright scratch marks, scuffs, and smears in soot/discoloration pattern indicates damage after soot/discoloration occurred.
- (19) Soot in torn edges of normally protected surfaces indicates fire after damage.
- (20) Soot can attach itself by unburned oils and by electrostatic attraction. Will not attach to surfaces over about 700°F.
- (21) Parts subjected to ground fire may have twigs, leaves, etc. outlined in soot pattern.
- (22) Burn pattern/soot uniformly across and into folds due to impact damage indicate fire prior to damage.
- (23) Explosions can occur with little to no thermal or soot evidence. Structure damage may be best evidence of an explosion.
- (24) Ground fire smoke/soot pattern sporadic - generally upward.
- (25) Rain, snow, and fire-fighting operation may affect soot pattern evidence.
- (26) Ground fire flame temperature may range between 1600°F to 2000°F for hydrocarbons.
- (27) Discoloration of torn edges and scratches may be due to residual heat in high mass parts.
- (28) Aluminum near the molten state and shock loaded will "broomstraw" or "feather."

- (29) Molten metal will not deposit on hot objects (>melting temperature of molten metal).
- (30) Parts or molten metal droplets may be found along flight path (ensure parts are from mishap aircraft).
- (31) Molten metal may be deposited by gravity, air flow, blast wave, or relative motion or a combination of the foregoing.
- (32) Melting temperatures of materials will establish minimum exposure temperatures.
- (33) Gas released from pressurized containers may give strange burn patterns. Nitrogen will tend to suppress the fire and high pressure air may give evidence similar to oxygen.
- (34) Rupture disks/thermal plugs on pressurized containers may give temperature/pressure information.
- (35) Discoloration of materials is a time/temperature function.
- (36) Oxygen release may result in severe burning often resulting in a white ash deposit.
- (37) Normal fire behavior causes upward extension more rapidly than lateral extension (no airflow).
- (38) Fire can spread by radiation, convection, and conduction.
- (39) Witnesses may give a different account of the same event (do not presuppose until several eyewitnesses' statements best support a conclusion). Make a matrix.
- (40) A braking spar can sound like an explosion.
- (41) Fuel and hydraulic fluid spray/mist may look like smoke.
- (42) Fire/smoke emissions, either internal or external to the aircraft, can be a good clue. Important to identify location, color, intensity, and time of emissions. NOTE: Location of witness and environmental background.
- (43) Did survivors/witnesses have the opportunity to discuss the mishap?
- (44) Qualification/background of witnesses (one man's "pop" is another man's "crack").
- (45) If possible, have key witnesses retrace their actions (location/time).
- (46) Fire alarm, response time, rescue efforts, status of fire, and equipment used; role of fire department, police department, and air control tower.

- (47) If time factors are questionable, request simulation or rerun, if possible.
- (48) Impact or fire may cause loose "B" nuts. If more than a quarter of a turn loose, not the result of a fire.
- (49) Electrical arcing damage will be localized, have an eroded appearance, and possible metal splatter. Strands of copper wiring may fuse together and little beads may form on the ends.
- (50) Electrostatic discharges (sparks not including lightning) may ignite hydrocarbon fuels. These sparks, however, do not have sufficient energy to leave any direct evidence (pits or discoloration, etc.).
- (51) Lightning strikes can result in both spark and arc ignition sources within the aircraft. Both may have sufficient energy to leave thermal evidence. Lightning also may result in hot surface ignition.
- (52) Component bonding at resistance less than 10^6 ohms is acceptable to prevent electrostatic charge build-up on the subject component.
- (53) Aircraft grounding will not always prevent electrostatic charge build-up within the aircraft.
- (54) Static electricity cannot be identified as the probable ignition source until all other possible ignition sources have been eliminated and a charge generating mechanism is identified.
- (55) Parts that separate from the aircraft prior to impact are excellent evidence.
- (56) Abnormal functioning subsystems may indicate fire location/time due to thermal damage of electrical wires, fluid lines, or control lines (a fire in a remote dry bay may affect a unique set of subsystem lines/wires, etc.).
- (57) Thermal damage of explosion suppression material (internal fuel tank foam) may lead to the wrong conclusion. Damage pattern generally sporadic and unpredictable insofar as establishing a fire pattern.

X. EXPLOSION DAMAGE ANALYSIS

A. EXPLOSION PRESSURES OF DEFLAGRATIONS

An explosion implies a sudden release of pressure or energy and can occur when flammable vapors are ignited in an oxidant atmosphere under some confinement. Aircraft fuel-related explosions are always deflagrations (subsonic) and not detonations (supersonic). The explosion pressures for the deflagrations of uniform gaseous mixtures may be calculated from the following expression for constant volume combustion (closed vessels):

$$P_2/P_1 = n_2T_2/n_1T_1 \quad (42)$$

where P is absolute pressure, T is absolute temperature, and n is moles of gas. For example, assuming a maximum flame temperature (T_2) of 2000°C (4092°R) for hydrocarbon fuel vapor-air mixtures and negligible change in the reactant and product gaseous moles ($n_1 = n_2$), the maximum explosion pressure (P_2) with P_1 at 1 atm and T_1 at 25°C (537°R) is

$$P_2 = \left(\frac{4092^{\circ}\text{R}}{537^{\circ}\text{R}} \right) \times 1 \text{ atm} = 7.6 \text{ atm (112 psia)}$$

Since T_2 of 4092°R is the maximum flame temperature, the final pressure of 112 psia is the maximum possible value for the hydrocarbon reaction at the stated initial conditions (P_1, T_1). Note that if the initial pressure (P_1) had been 10 atms in the above example, P_2 would have been 76 atms.

In addition to initial pressure (P_1) and temperature (T_1) effects, explosion pressures in closed vessels will vary with the composition or concentration of the fuel, oxidant, and any inerting or inhibiting agent; ignition source energies can also be a factor. Fuel concentration effects on explosion pressures are illustrated in Figure 48 (Ref. 1) for the spark ignition of a gaseous hydrocarbon fuel (methane) premixed with air. Note that explosion pressures are maximum near stoichiometric and that even the compositions near the lower and upper limits of flammability yield substantial pressures. Inerting effects are illustrated by the pressure histories in Figure 49 (Ref. 55) for stoichiometric methane-air with added nitrogen and Figure 50 (Ref. 55) with added Halon 1301 (CF_3Br), a fire extinguishing agent; inert concentrations greater than those shown gave little pressure rise in the large explosion vessel (920 ft.³) used. From the explosion suppression standpoint, it is apparent that the suppression system should be triggered early to avoid the high pressures that can develop with insufficient agent.

Explosion pressures of (uniform) jet fuel vapor-air mixtures will be comparable to those of methane mixtures having the same equivalence ratio or flame temperature; equivalence ratio at a stoichiometric fuel-air concentration is unity. Inerting effects on these pressures will also be similar to the trends displayed by methane. However, in an aircraft fuel tank, the fuel vapor concentrations are usually nonuniform and will vary with fuel volatility at the ambient temperature and pressure. As a result, the explosion pressures are lower than encountered with uniform vapor-air mixtures and are lowest when the fuel temperature is below its flash point. This is evident in Figure 51

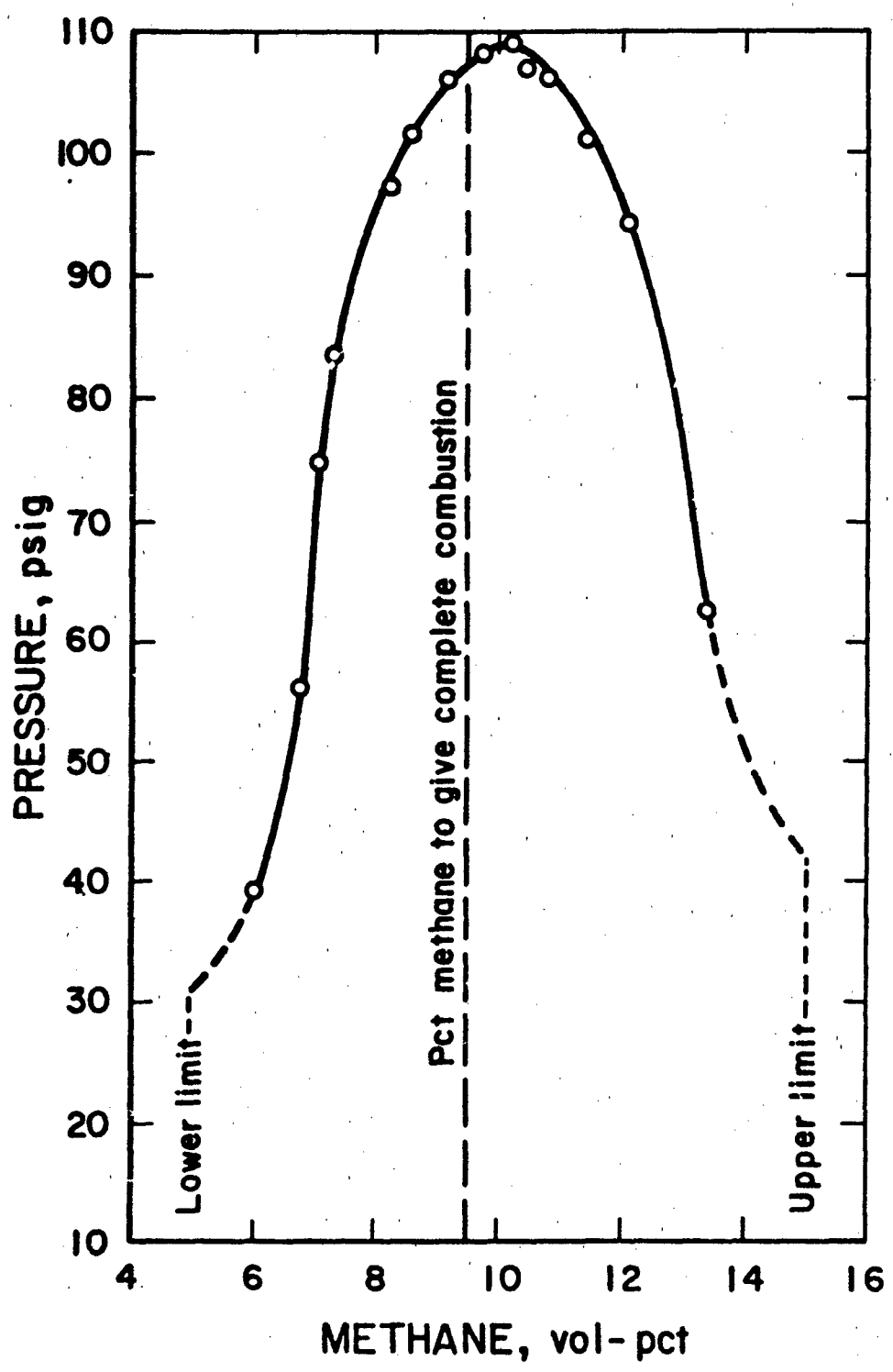

Figure 48. Effect of Fuel Concentration on Explosion Pressure for Methane-Air Mixtures at 25°C (77°F) and 1 atm (244 in.³ vessel).

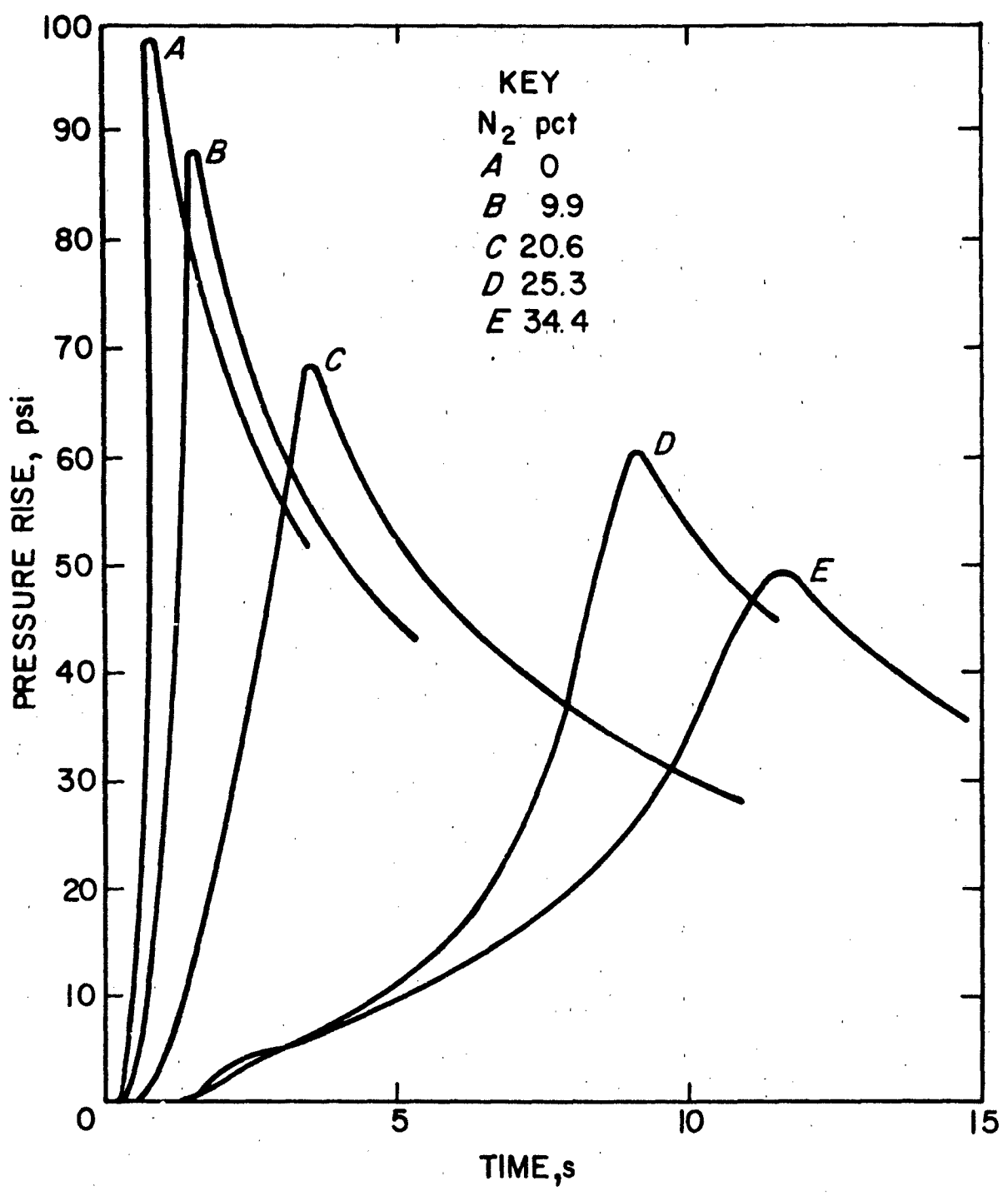

Figure 49. Explosion Pressure Histories for Stoichiometric Methane-Air Mixtures with Added Nitrogen at 25°C (77°F) and 1 atm (920 ft.³ vessel).

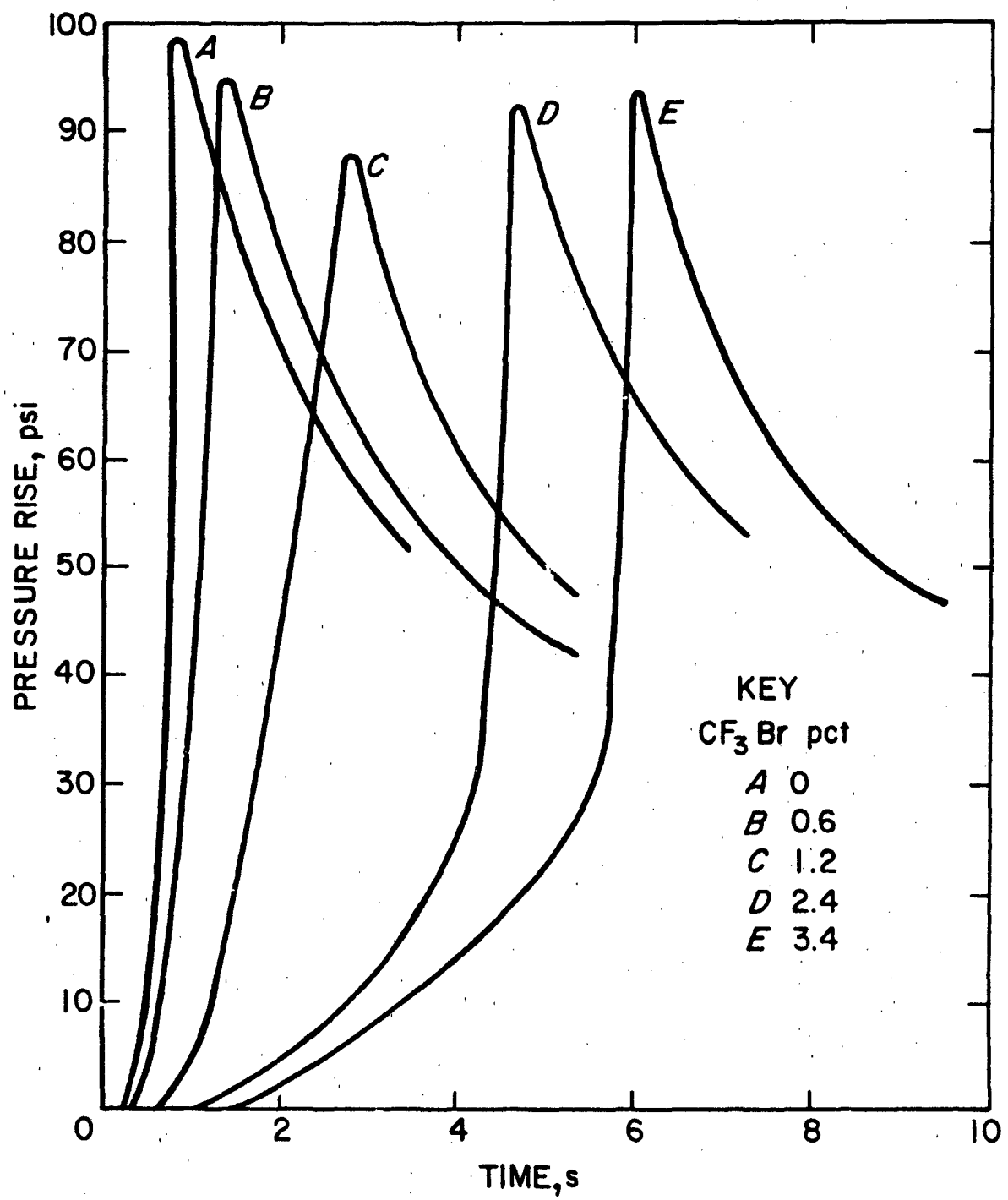

Figure 50. Explosion Pressure Histories for Stoichiometric Methane-Air Mixtures with Added Halon 1301 (CF₃Br) at 25°C (77°F) and 1 atm (920 ft.³ vessel).

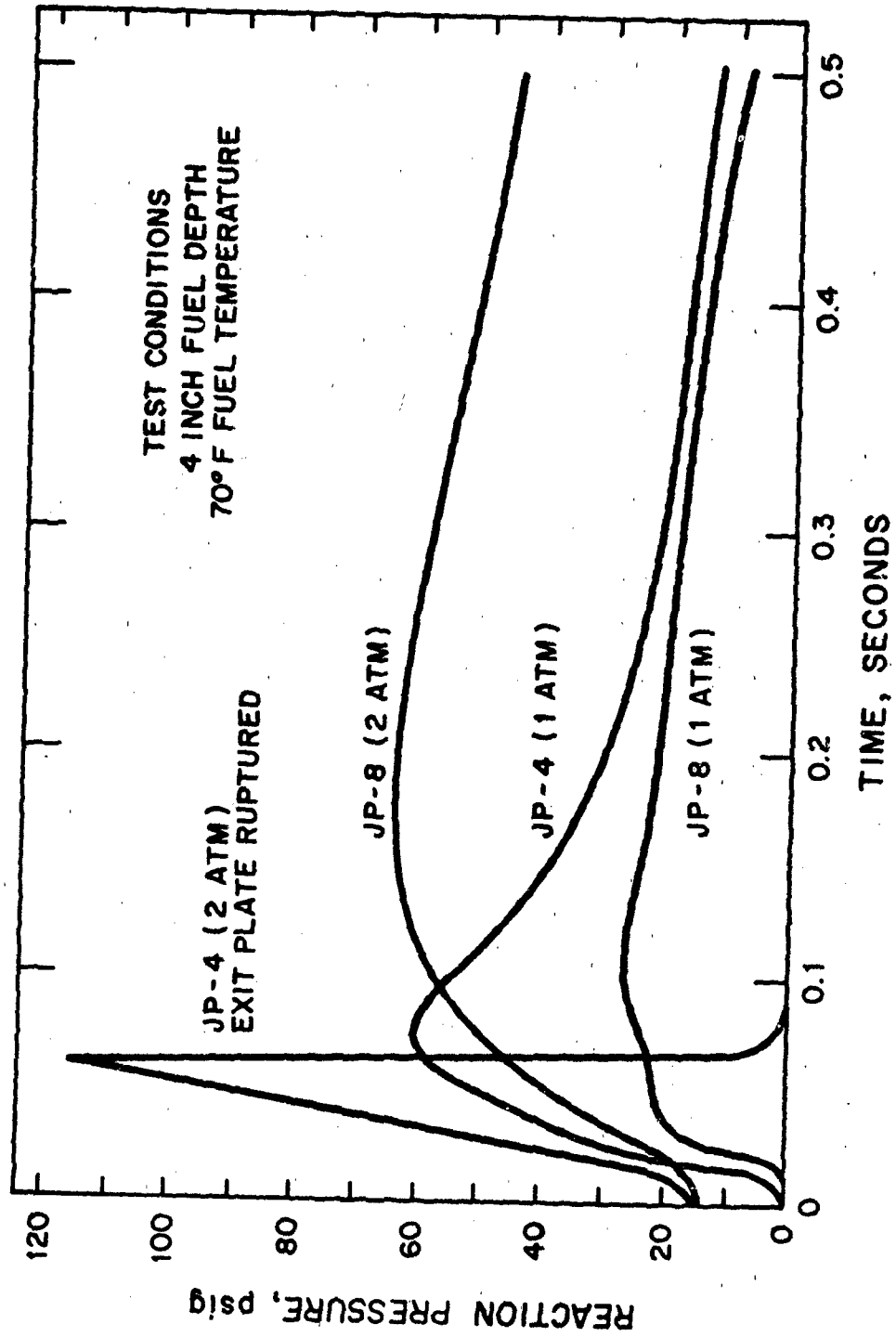

Figure 51. Typical Pressure - Time Profiles from Incendiary Firings (60° Upward Pitch) into a 92-Gallon Tank (12.3 ft. 3) Containing JP-4 and JP-8 Jet Fuels at 1 and 2 Atmospheres Initial Pressure (50 caliber API, Type M-8, Ammunition).

(Ref. 56) where the use of a strong ignition source (incendiary) also shifts the temperature range of flammability; the lower temperature limit for JP-8 (~115°F) is expanded downward and the upper temperature limit for JP-4 (65°F) is increased. Explosion pressures for the JP-5 fuel tend to be equal or slightly less than for the JP-8 fuel.

Assuming spherical flame propagation, pressure rise rates (dP/dt) or times (t) to maximum pressures will be approximately extrapolated to various vessel volumes (V) from their cube root dependence upon volume:

$$\frac{(dP/dt)_1}{(dP/dt)_2} = \frac{t_2}{t_1} = \left(\frac{V_2}{V_1}\right)^{1/3} \quad (43)$$

where subscript 2 refers to the larger size vessel. For hydrocarbon fuel vapor-air explosions, the following expression may be used (Ref. 12):

$$t = 75 V^{1/3} \quad (44)$$

where t is time to maximum pressure in milliseconds and V is in cubic feet. A more general expression based upon flame speed (S_f) or burning velocity (S_u) is

$$t = \frac{\text{Vessel Radius}}{S_f} = \frac{\text{Vessel Radius}}{E S_u} \quad (45)$$

where S_u and E (expansion ratio = S_f/S_u) for constant pressure combustion may be assumed. An S_u value of about 1.5 ft./sec. or S_f of about 10 ft./sec. is applicable to hydrocarbon fuels in atmospheric air.

Explosion pressures of gaseous mixtures can be relatively low when the fuel system is protected by flame arrestor devices. The effectiveness of a reticulated polyurethane foam that is used to protect fuel tanks depends greatly upon the arrestor length, arrestor porosity, fuel tank pressure, and free tank volume or flame run-up distance (Figure 52, Ref. 57). A 10 pore/inch foam results in little pressure rise at 1 atmosphere pressure if the fuel tank is fully packed; 20 pores/inch or more is required for a partially packed tank or for ignitions at higher initial pressures (≥ 5 psig). Metal flame arrestors (e.g., wire gauze) can be equally or more effective than the above foam arrestors because of their greater heat capacity and ignition resistance. The variation of arrestor effectiveness with the flame approach velocity is defined by equation 27.

Lower pressures also result in vented gaseous explosions. If the explosions occur in ducts, the maximum pressures may be approximately calculated by (Ref. 20)

$$P_m = 1.8 K \quad ; \quad K = 2 \text{ to } 32 \quad (46)$$

$$P_m = 0.35 L/D + 0.9 K \quad ; \quad K = 1 \text{ to } 2 \quad (47)$$

where P_m is maximum pressure during venting (psi), K is ratio of duct cross-sectional area to vent area, and L/D is length/diameter ratio of duct. These equations are limited to unobstructed ducts, L/D values between 6 and 30, and flame speeds less than 3 m/sec. (<10 ft./sec.). A similar expression for venting large buildings is given by (Ref. 58):

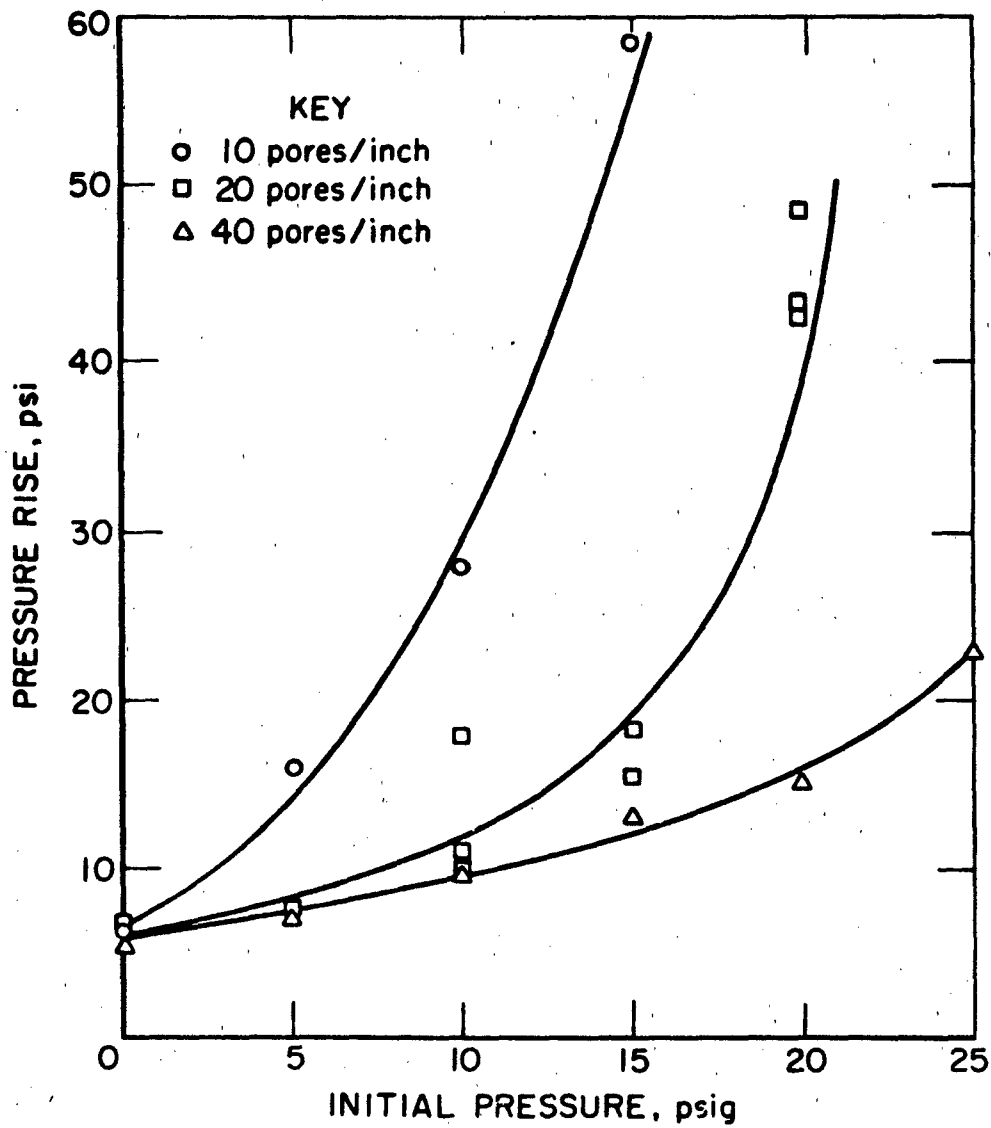

Figure 52. Effectiveness of Polyurethane Foam in Quenching Ignitions of Near-Stoichiometric n-Pentane-Air Mixtures (75°F) in a Cylindrical Vessel (6 in. diam. x 60 in. length); Arrestor Length/Ignition Void Length = 30 in./18 in. (1.67).

$$P_m = 1.5 P_v + 0.5 K \quad ; \quad K = 1 \text{ to } 5 \quad (48)$$

where P_v (psi) is pressure when venting starts and K is ratio of smallest cross-sectional area of building to total vent area. This equation is applicable to propane-air or similar mixtures and is limited to length/width ratios of up to 3 and vent materials that rupture or open below 1 psi. Thus, with a large vent area ($K = 1$), the maximum pressure (P_m) would not exceed 2 psi by this equation. Venting data obtained with propane-air mixtures in a small enclosure (3 ft.³) are shown in Figure 53 (Ref. 59). Here, a vent area of about 5 ft.² per 100 ft.³ tank volume would be required to insure explosion pressures below 5 psi.

Venting parameters and corresponding explosion pressures may be calculated from the properties of the gaseous mixture (Ref. 60). The expression derived for venting hydrocarbon vapor-air explosions in buildings, tanks, or other large enclosures is given by

$$A = 13.03 \times 10^{-3} V^{2/3} (E - 1) S_u / c_d \left(\frac{E \rho_u}{P - P_o} \right)^{1/2} \quad (49)$$

where A is vent area (m²), V is enclosure volume (m³), E is expansion ratio of combustion products (S_f/S_u), S_u is burning velocity (cm/sec.), c_d is vent discharge coefficient, ρ_u is density of unburned gas (g/cc), and $(P - P_o)$ is the pressure rise (psig). For stoichiometric combustion of jet fuel vapor-air mixtures, one may assume the following: $S_u = 45$ cm/sec., $E = 7.5$, and $c_d = 0.8$. Figure 54 shows predicted pressure rises ($P - P_o$) as a function of the vent ratio ($A/V^{2/3}$) for methane-air ignitions with 0, 10, 20, and 30% added nitrogen at 80°F (27°C) and 1 atm. The predicted values are most reliable for large enclosures with unrestricted vents and relatively small length/diameter ratios.

B. EXPLOSION PRESSURES OF DETONATIONS

Detonations of gaseous fuel-oxidant mixtures normally require a strong oxidizer such as oxygen, a very strong initiation source, or special propagation conditions that accelerate the deflagration to a detonation. The detonation pressure (P_d) for gaseous mixtures is given approximately by (Ref. 61)

$$P_d = 2 P_v \quad (50)$$

where P_v is the maximum absolute pressure (~8 atm) for constant volume combustion; note that P_v is equivalent to P_2 (maximum explosion pressure) in equation 42. The maximum pressure rise ratio (P_2/P_1) will be about 16:1 to 18:1, although the ratio for reflected pressures can be of the order of 40:1 in such detonations.

Generally, if detonations occur in aircraft accidents, these will most likely involve high explosives such as those used in ordinance items. Their detonation pressures tend to be in excess of 100×10^3 atmospheres (Table 23). Their blast wave pressures will vary with distance and are characterized in the section on blast wave damage criteria.

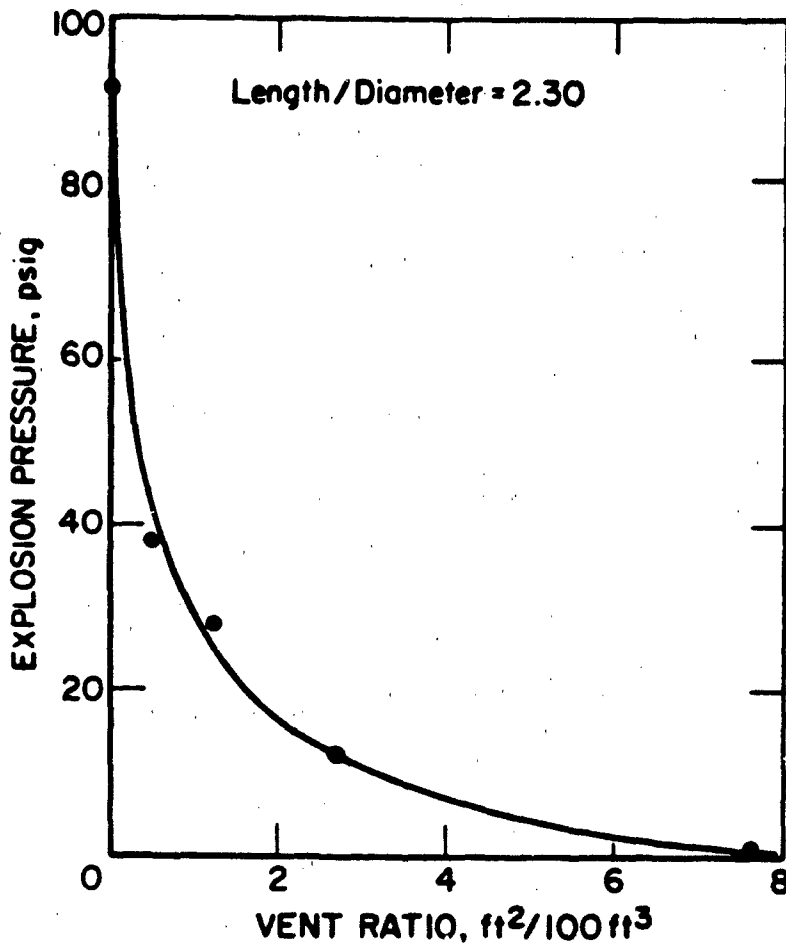

Figure 53. Effect of Vent Ratio on Explosion Pressure for 5% Propane-Air Mixtures (75°F) in a 3 ft.³ Tank at Atmospheric Pressure.

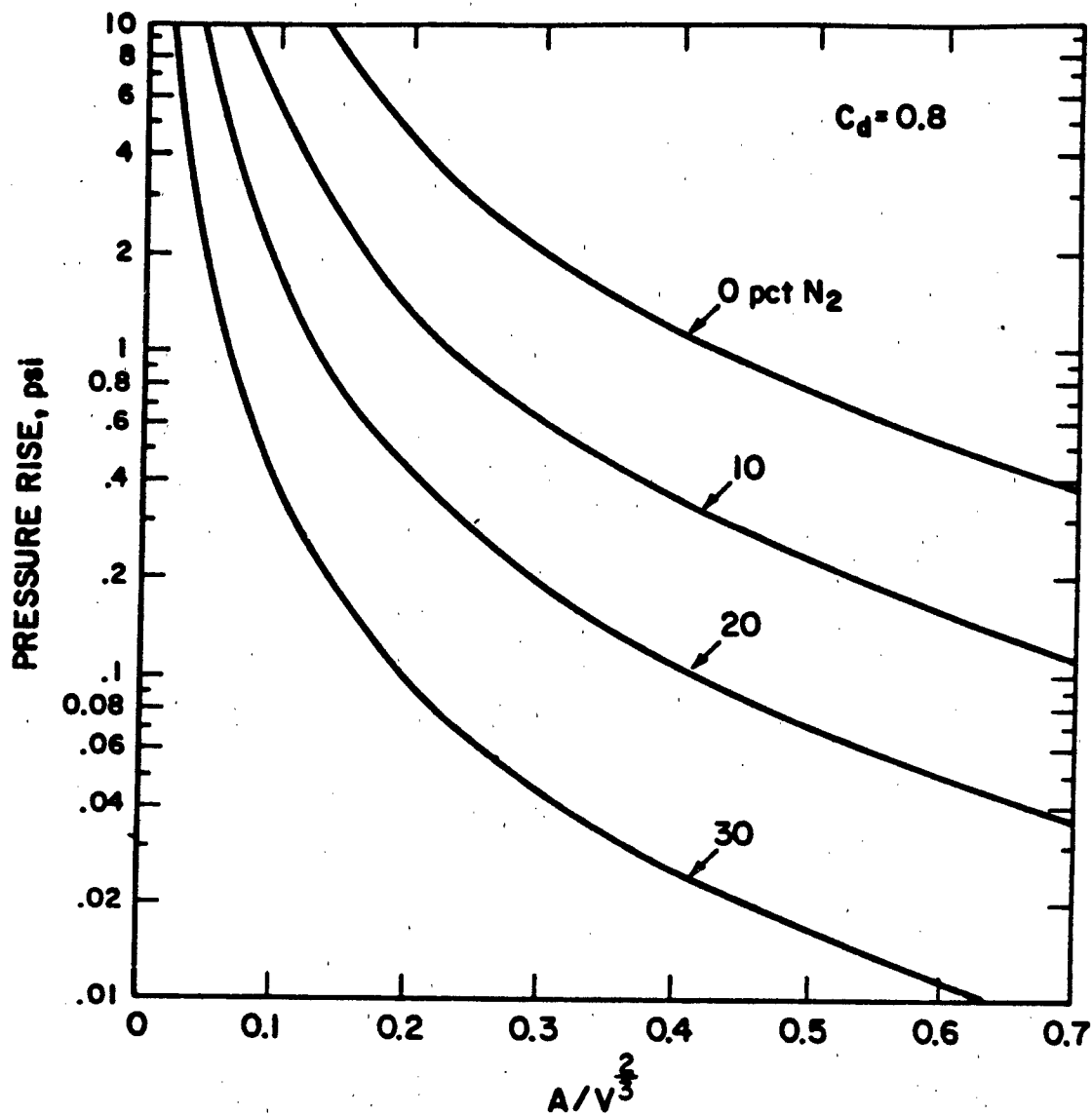

Figure 54. Calculated Pressure Rise vs. Vent Ratio ($A/V^{2/3}$) for Stoichiometric Methane-Air Ignitions with Added Nitrogen at 25°C (77°F) and 1 atm.

C. EXPLOSION PRESSURE DAMAGE CRITERIA

Pressure damage from a combustible gas explosion will depend primarily upon the strength of the container material (including fasteners) and the nature of the stress or pressure loading on the container. The failure of a spherical or cylindrical container may occur as a result of excessive hoop stress (lateral) or tensile stress (longitudinal):

$$\text{Hoop stress (lateral)} - S_h = EP r/t \quad (51)$$

$$\text{Tensile stress (longitudinal)} - S_t = EP r/2t \quad (52)$$

where S is stress (psi), P is container pressure (psi), E is efficiency of weld, and r (in) and t (in) are radius and thickness of the container, respectively; E is often assumed to be near unity. Data in Table 36 (Refs. 30, 47) define the stress required to produce deformation (yield strength) and tensile failure (tensile strength) of various metals and alloys. The pressure loading (P) that may be expected in fuel tank explosions have been described previously and will normally not exceed 8 atmospheres (118 psia) in aircraft situations. In applying the above equations, it must be realized that the stresses and pressures for material failure can be 2 to 3 times greater under explosive dynamic conditions, as opposed to static conditions (Ref. 19). Pressure ratings of vessels or tanks usually are specified for static-type loadings. Experience shows that the pressure for vessel failure is approximately twice the elastic limit of the vessel material. Although some aircraft fuel tanks may fail in weak explosions, those which have the strength of external fuel tanks can withstand explosion pressures of up to about 3 or 4 atmospheres.

The pressure loading in container failures may be uniformly or nonuniformly distributed over the surface area of the container. Uniform loading may be assumed in fuel tank gaseous explosions (deflagrations). Where the container is equipped with bolt or screw fasteners, the pressure loading is fully borne by the fasteners, assuming the container walls have not failed; the cross-sectional areas of the bolts or root thread areas of the screws are used in calculating their pressure loading. The force (F , lb) from any uniformly applied stress (S , lb/in.²) to a given area (A , in.²) is given by

$$F = SA \quad (53)$$

The stress that is present from tightening a bolt cannot be neglected since this initial load may even exceed the tensile strength of the material. Failure of many fasteners or large sections of the container is evidence of uniform pressure loading.

Material damage will generally be greatest under high pressure or impact loadings. In gaseous explosions, the failure of a high strength container can produce very severe damage since near-theoretical explosion pressures may develop before the container ruptures. The type of material failure (e.g., tensile, shear, compression, etc.) is useful evidence in determining the nature and direction of the damaging force. Four types of metal failures are described below.

Tensile failure is characterized by "necking down" of the material with fractured edges inclined approximately 45 degrees to the direction of loading. The metal stretching is greatest for those of high ductility and

TABLE 36 MECHANICAL PROPERTIES OF METALS AND ALLOYS*

Material	Condition	Yield Strength kpsi	Tensile Strength kpsi
Aluminum alloy (1100)	Annealed - 0	5	13
Aluminum alloy (1100)	Cold-rolled- H 18	22	24
Aluminum alloy (5052)	Annealed - 0	13	28
Aluminum alloy (5052)	Cold-rolled/stabilized-H 38	37	42
Aluminum alloy (380)	Die-cast-F	26	43
Aluminum bronze (612)	Hard	65	105
Brass, red (230)	Cold-rolled	60	75
Copper (102)	Cold-drawn	40	45
Cupronickel (55-45)	Cold-drawn	50	65
Duranickel	Annealed	45	100
Hastelloy (B)	Rolled	56	120
Hastelloy (G)	Sheet	46	102
Incoloy (800)	Annealed	40	90
Inconel (600)	Cold-drawn	100	130
Inconel (610)	As cast	38	80
Iron, wrought	Hot-rolled	30	48
Iron, gray cast	As cast	NA	>25
Magnesium alloy (AZ80A)	Extruded	36	49
Monel (400)	Cold-drawn	80	110
Nickel alloy (220)	Annealed	20	70
Permanickel	Annealed, age-hardened	125	175
Stainless steel (201)	Annealed, strip	50	115
Stainless steel (304)	Annealed	30	85
Stainless steel (304)	Cold-rolled	<160	<185
Stainless steel (321 and 347)	Cold-rolled	<120	<150
Stainless steel (420)	Heat-treated	200	250
Stainless steel (cast 12 Cr)	Tempered at 315°C	150	200
Stainless steel (cast 20 Cr)	Annealed	60	95
Steel, carbon (SAE 1020)	Hot-rolled	42	68
Tantalum (10W)	Annealed	158	160
Tin	As cast	NA	2
Titanium (pure)	Annealed	75	85
Zircaloy (2)	Annealed	50	75

NA - Not available.

* References 30 and 47.

least for brittle ones or those of little ductility (see Figures 55, 56, 57 - Ref. 62). Gaseous explosions (deflagrations) in fuel tanks normally result in tensile failures.

Shear failure is typically evidenced by smooth fractured surfaces, no "necking down," and with the plane of fracture in the direction of loading (Figure 58 - Ref. 62). Shear failure of bolts or rivets may also be accompanied by elongation of the fastener hole. Shear failure of thin metal sheets will be indicated by buckling in a diagonal fashion. Detonations or severe impacts frequently produce shear failures.

Compression failure is indicated by buckling or crippling of the material or by a diamond shape buckle (Figures 59, 60 - Ref. 62). A container implosion or high impact loading can produce such failures.

Fatigue failure is evidenced by a discontinuity in the fracture pattern with two distinct zones, a relatively smooth fracture and a rough fracture (Figure 61 - Ref. 62).

Other types of material failures, such as torsion, tearing, and bending, will display the features of tension, shear, or compression.

As opposed to fires, explosions of aircraft fuel tanks frequently display little evidence of soot formation or thermal damage. Some soot can form when the explosion involves a fuel-rich gaseous mixture; the soot may be found on the walls of the fuel tank vents or other openings that may serve as explosion vents. Thermal damage from contact with the hot explosion gases also may be found in the fuel tank vents; a high energy ignition source such as lightning also may produce thermal damage to a fuel tank. The best evidence of an explosion will come from structural failure analyses.

D. BLAST WAVE DAMAGE CRITERIA

Prior discussion has been limited to the near-field effects of explosions, particularly deflagrations. Blast waves or shock waves may also be generated in gaseous explosions and, thereby, produce far-field effects. The blast wave energy will depend upon the fraction of available chemical energy (heat of combustion, ΔH_c) that is converted into pressure energy. Assuming isothermal expansion, the total work output (W) is

$$W = n RT \ln P_1/P_2 \quad (54)$$

and for adiabatic expansion

$$W = \frac{P_1 V_1 - P_2 V_2}{\gamma - 1} \quad (55)$$

where the symbols have the same meaning as in equation 6. By these equations, the isothermal expansion of 1 ft.³ of gas from 3000 psia to 200 ft.³ at 15 psia would yield 2895 Btu or 1.5 lbs. of equivalent TNT; a ΔH value of 1100 cal/g or 1,980 btu/lb. generally is used as the energy yield of TNT (Ref. 19). The corresponding work energy for adiabatic expansion is approximately 0.5 lbs of TNT. An intermediate value would represent most real situations. Large-scale studies (Refs. 19, 61) indicate the following explosion confinement effects:

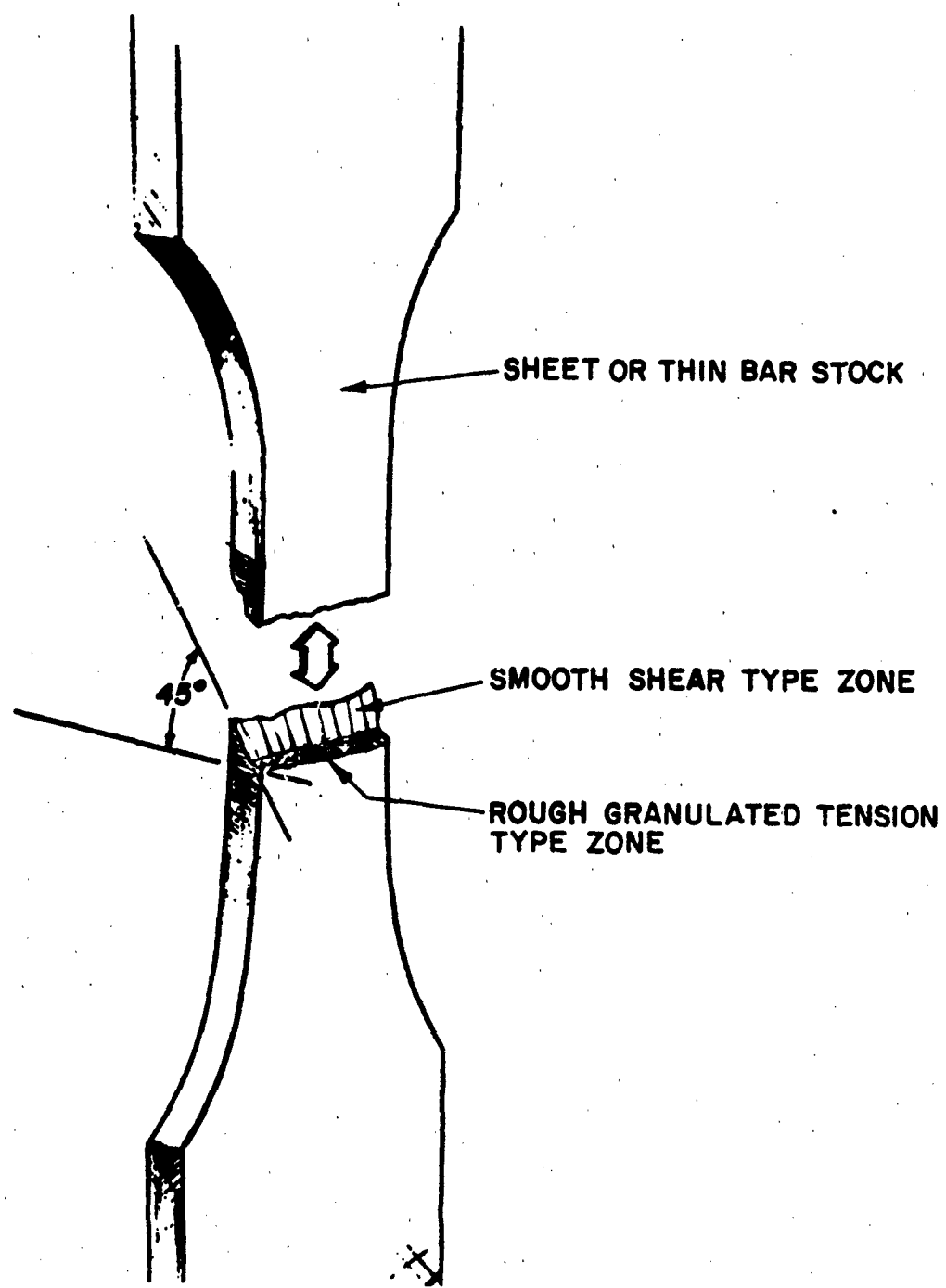

Figure 55. Highly Ductile Tension Failure

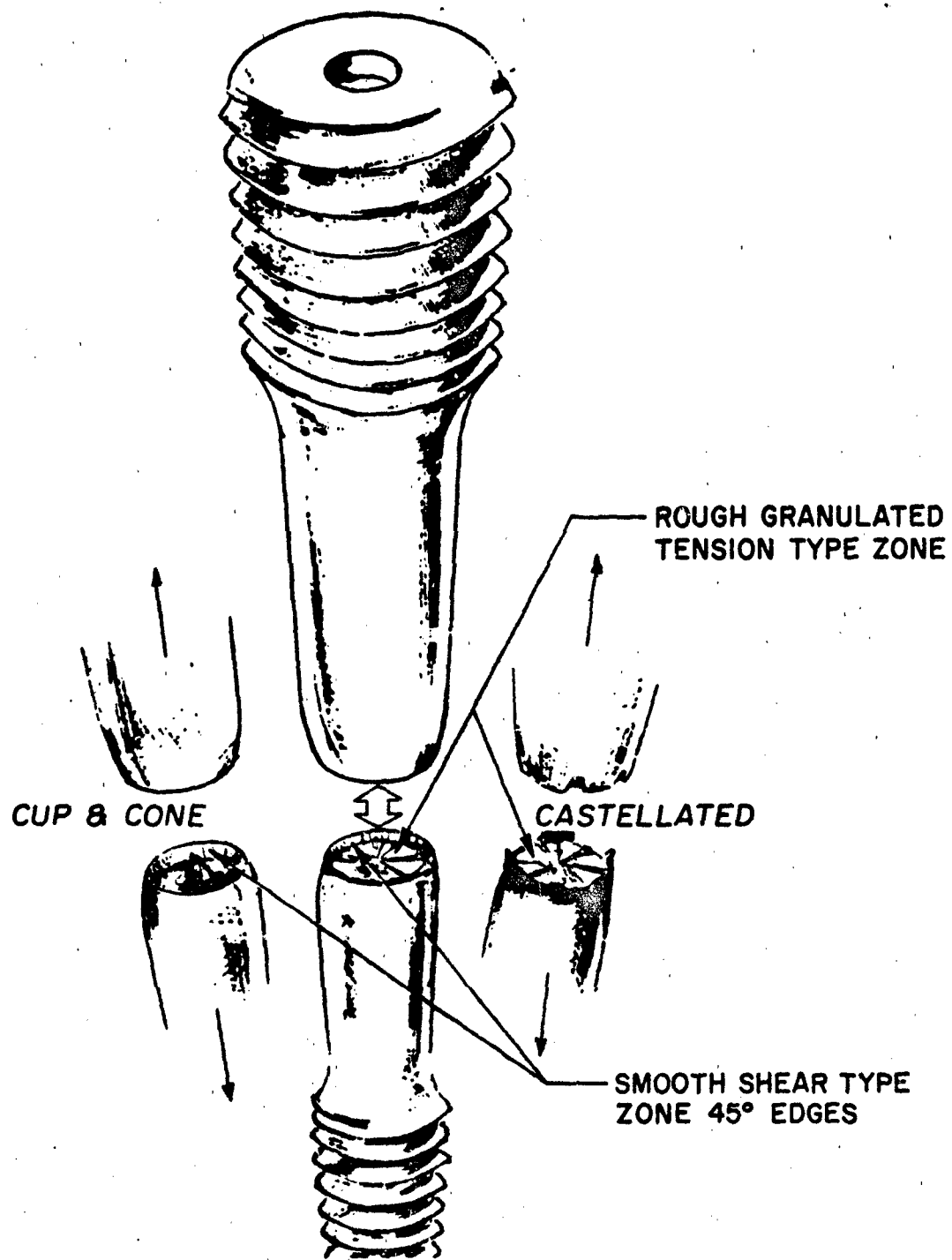

Figure 56. Medium Ductile Tension Failure

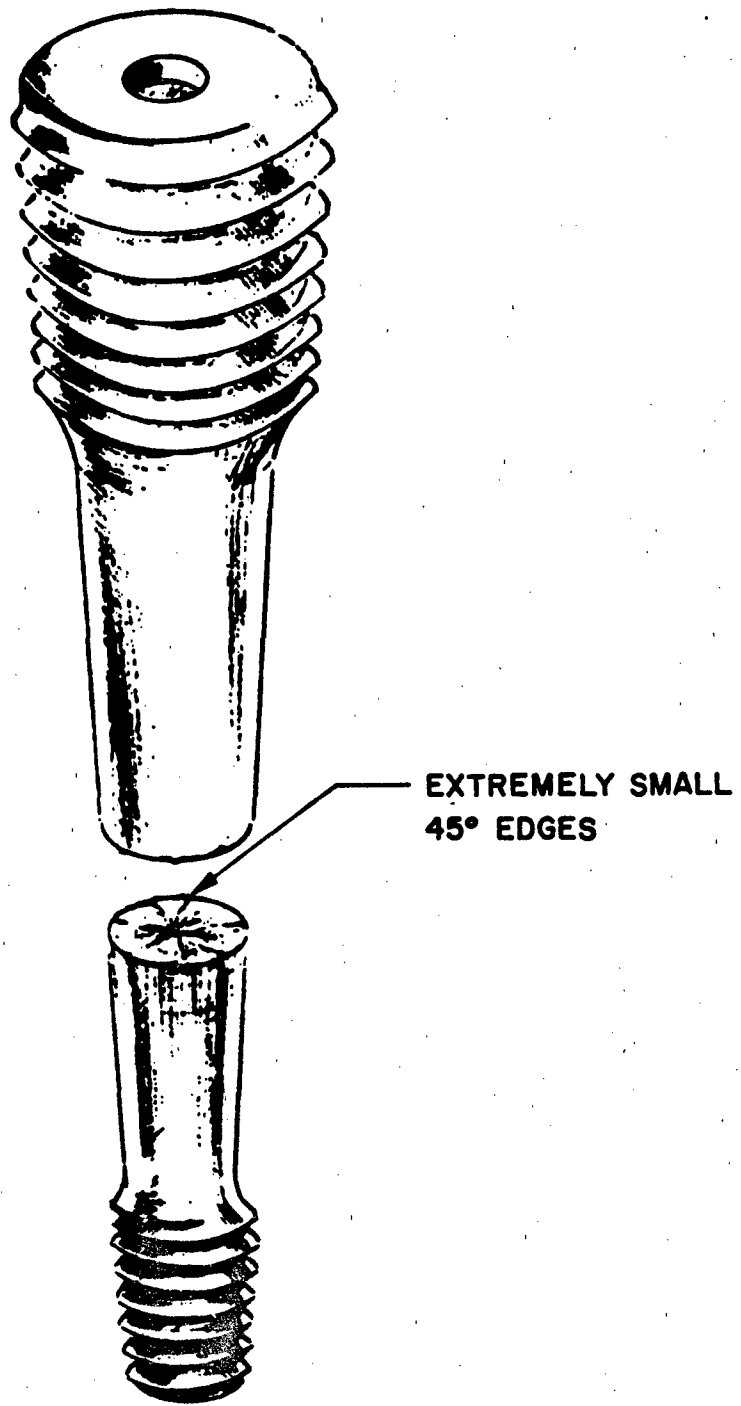

Figure 57. Brittle Tension Failure

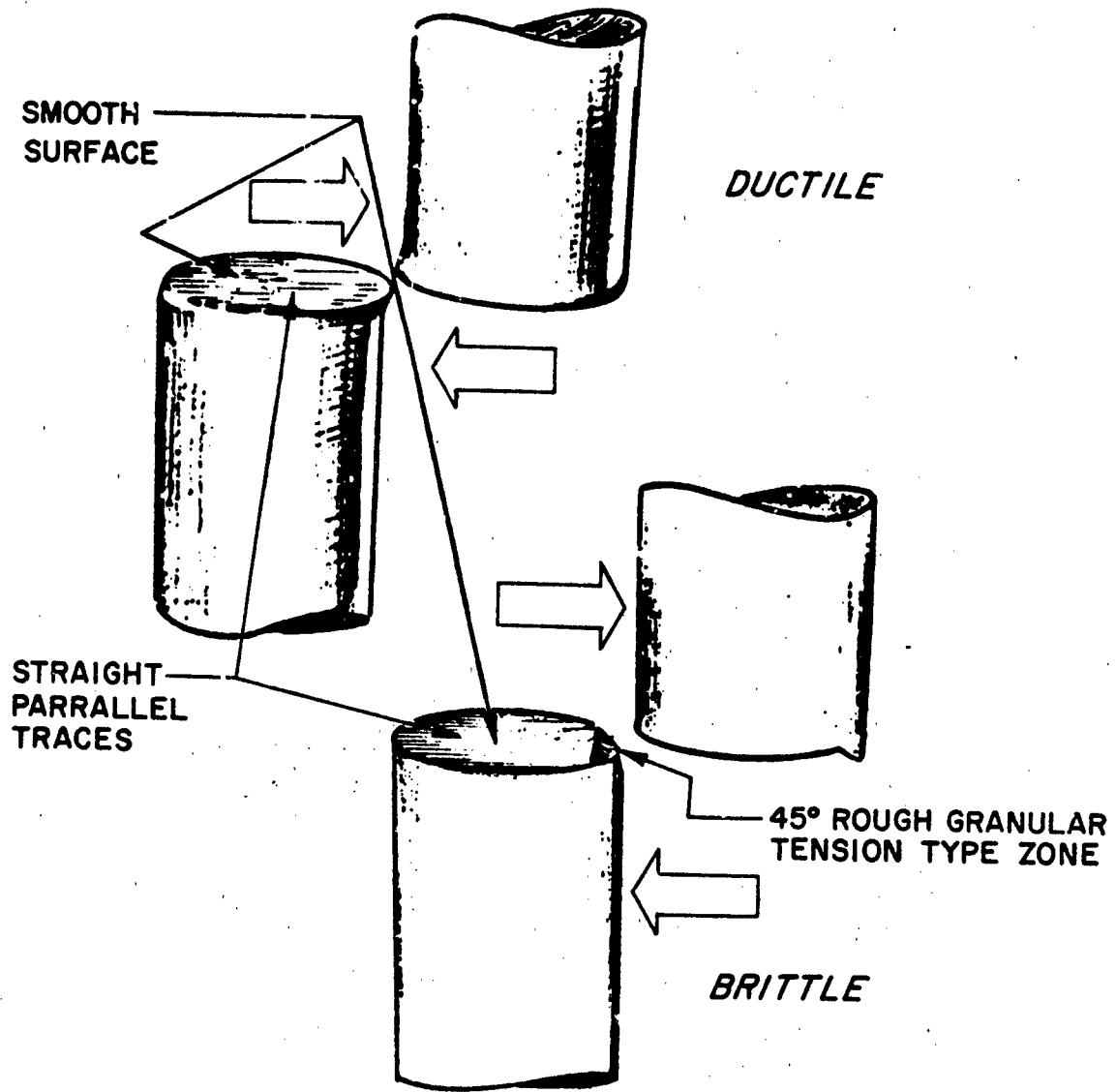

Figure 58. Shear Failure

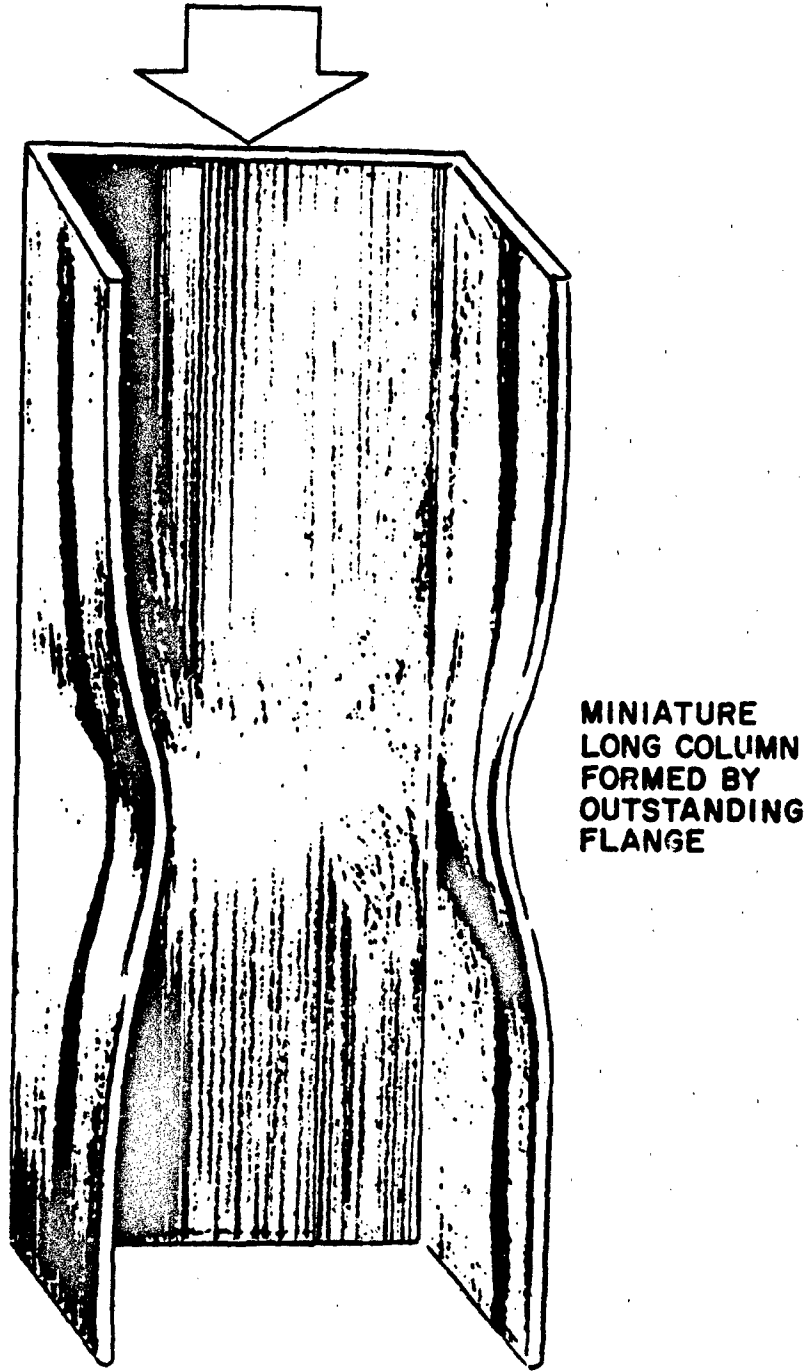

Figure 59. Local Crippling in Compression Failure

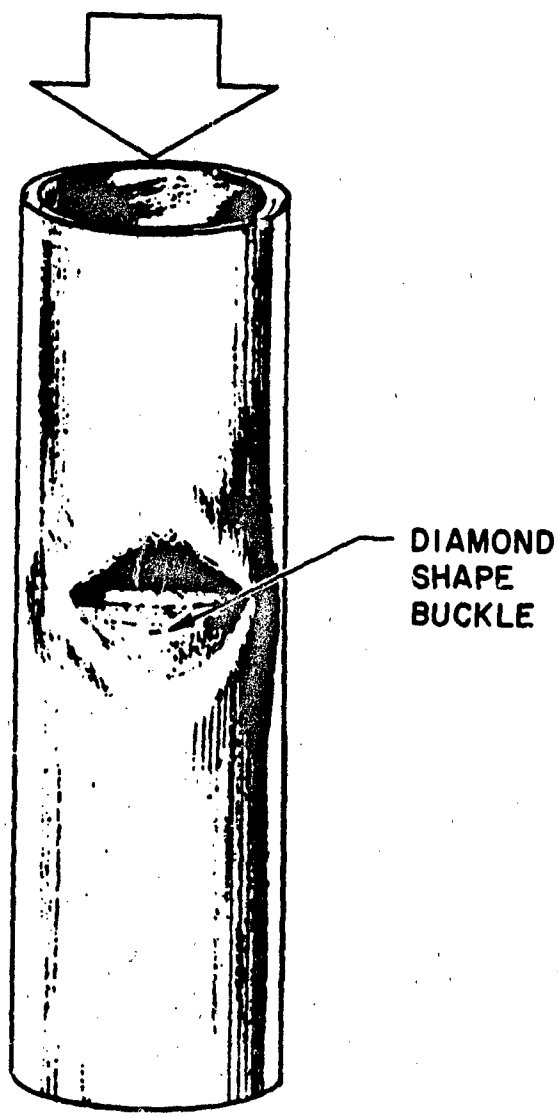

Figure 60. Compression Failure with Diamond Shape Buckle

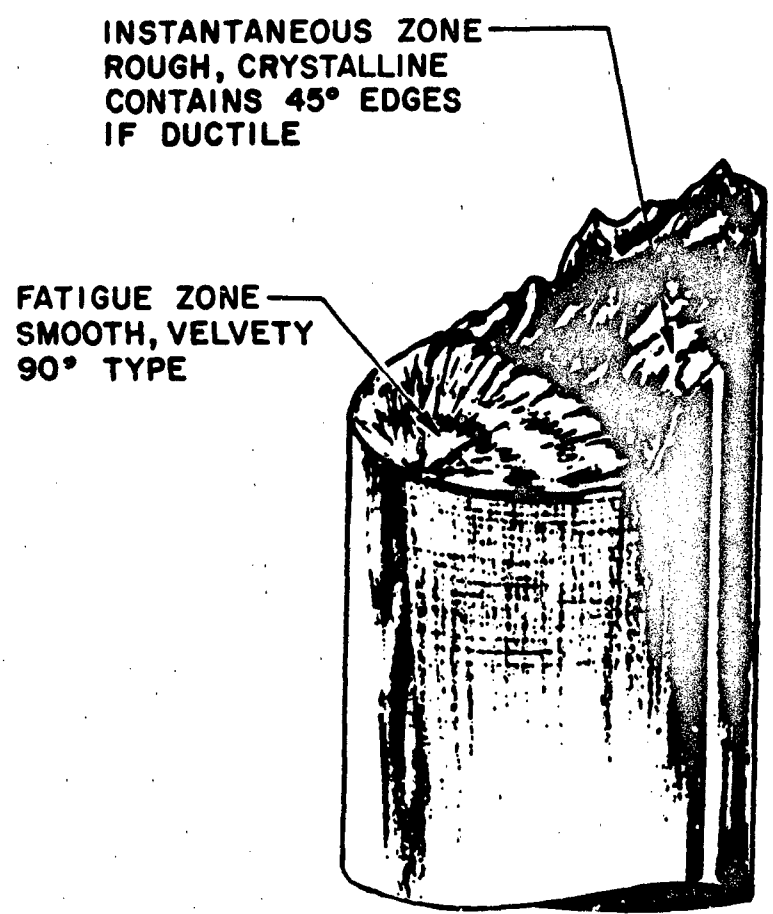

Figure 61. Fatigue Failure

- (1) In gaseous deflagrations that are weakly confined, little of the chemical energy (<10%) will be converted to pressure energy.
- (2) In strongly confined deflagrations, a small fraction of the chemical energy (~10%) generally will be used to cause container failure and the pressure energy will be slightly less than the chemical energy.
- (3) In weakly confined gaseous detonations, the TNT equivalent is given by the chemical energy.

The TNT equivalence of a strong explosion is obtained by invoking the cube root scaling law (Ref. 63) which relates the blast pressure potential of the exploding charge at any weight (W) and distance (d) relative to that of TNT:

$$d/d_0 = (W/W_0)^{1/3} \quad (56)$$

where d_0 and W_0 refer to TNT. By defining a scaled distance (λ) as

$$\lambda = d/W^{1/3} \quad (57)$$

a generalized chart such as Figure 62 (Ref. 64) may be used in relating TNT equivalences to peak overpressures. For example, if an exploding mixture has a TNT equivalence of 1 lb. (454 g), the peak overpressure (blast wave pressure) would be approximately 10 psi at a distance of 10 ft.; 10 lbs. of TNT would result in a peak overpressure of about 50 psi at the same distance.

Blast wave damage that may occur to structural materials or buildings is given in Table 37 (Ref. 63) and Table 38 (Ref. 65) in terms of incident peak overpressure and scaled distance, respectively; Figure 62 should be referred to for correlating the above data in terms of either parameter. As an example, total destruction of a building can occur at a scaled distance (λ) of 7.4 ft./lb.^{1/3} (Table 38), which corresponds to an incident peak pressure of approximately 11 psi by Figure 62. Note in Table 37 that most ordinary constructional materials will fail with only a few psi overpressure; these values are for external loading and can be lower for internal loading, as in a fuel tank explosion. Data by the same author also showed that an average sized aircraft would suffer severe damage at a blast overpressure of approximately 3 psi and only slight damage at 1 psi. Maximum pressure damage to structural materials will occur to those of minimum thickness and maximum width (or diameter) and without any material supports or reinforcement.

Biological effects of incident blast overpressures are summarized in Figure 63 (Ref. 66) together with certain material failures. The biological effects are for a pressure pulse duration of 400 ms and would require substantially higher overpressures than shown if the pulse duration was much shorter. Table 39 gives threshold overpressures for eardrum rupture, lung damage, and lethality where the pressure pulses are of only a few milliseconds duration; short pulse durations are characteristic of aircraft explosions. An overpressure of 1 psi is reported to be sufficient to knock over an average human body (Ref. 63). In comparison, the lethal overpressure is about 50 psi at a 50% probability level (Figure 63).

TABLE 37 PEAK OVERPRESSURES FOR FAILURE OF STRUCTURAL MATERIALS*

Structural Material	Usual Failure	Peak Blast Overpressure (psi)
Glass windows	Shattering	0.5 - 1.0
Corrugated asbestos siding	Shattering	1.0 - 2.0
Corrugated steel or aluminum paneling	Connection failure and buckling	1.0 - 2.0
Wood siding panels (standard house construction)	Connection failure, and buckling	1.0 - 2.0
Concrete or cinderblock walls, 8 or 12 inches thick (not reinforced)	Shattering	2.0 - 3.0
Brick walls, 8 or 12 inches thick (not reinforced)	Shearing and flexure failures	7.0 - 8.0

* Reference 63.

TABLE 38 SCALED DISTANCE FOR BUILDING DAMAGE FROM STATISTICAL SURVEY OF CHEMICAL EXPLOSIONS*

Category	Building Damage	Scaled Distance (λ)	
		ft/lb ^{1/3}	m/kg ^{1/3}
A	Demolished, not standing	7.4	2.9
B	Severe damage; standing but substantially destroyed, some walls gone	16.6	6.6
C	Moderate damage; walls bulged, roof cracked or bulged, studs and rafters broken	25.0	9.9
D	Slight damage; doors, sashes, or frames removed; plaster or wallboard broken; shingles or siding off	28.1	11.2
E	Minor damage to glass or miscellaneous small items (similar to that resulting from high wind)	42.7	17.0

* Reference 65.

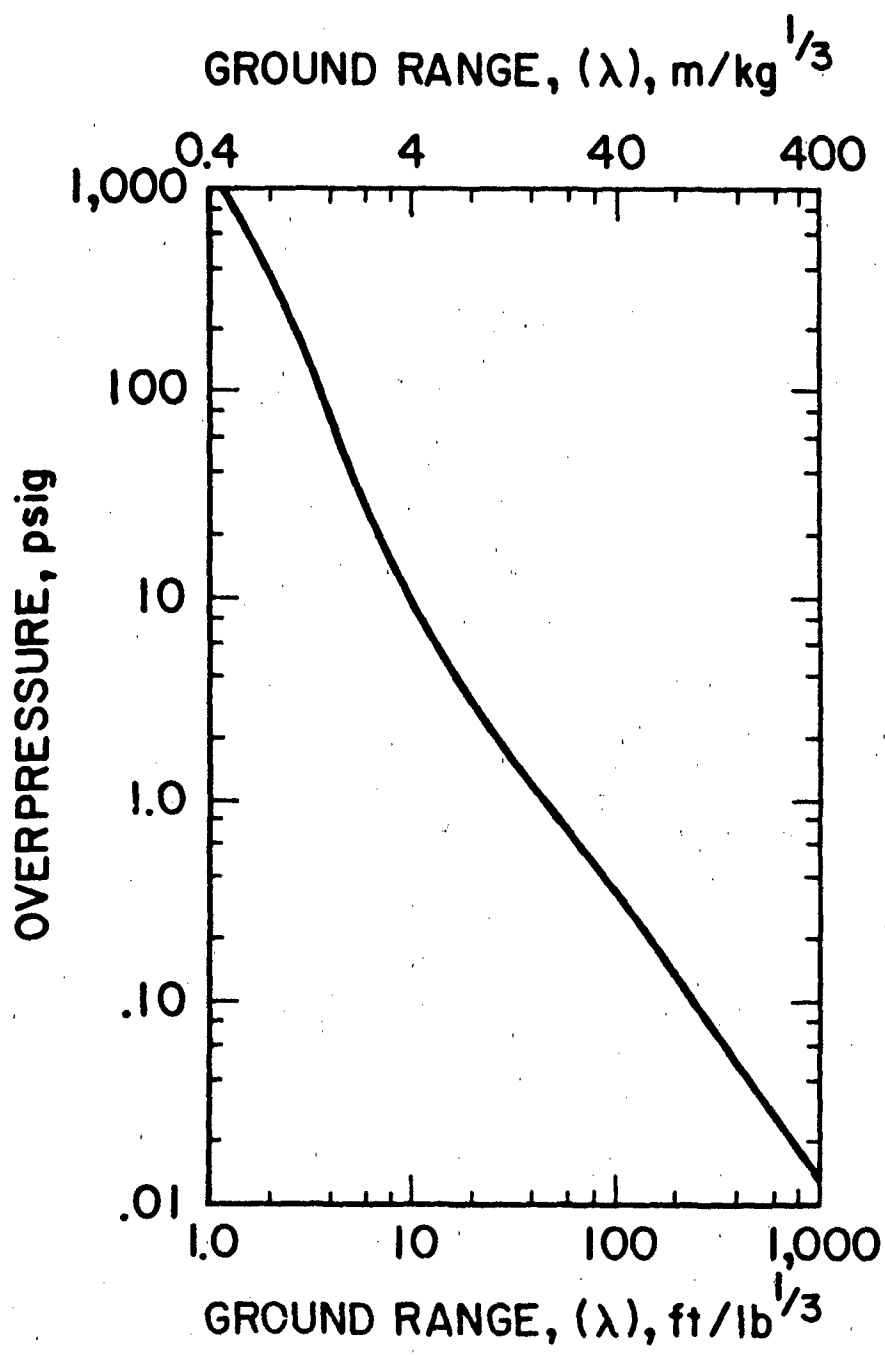

Figure 62. Peak Overpressure vs. Scaled Distance for Hemispherical TNT Surface Bursts

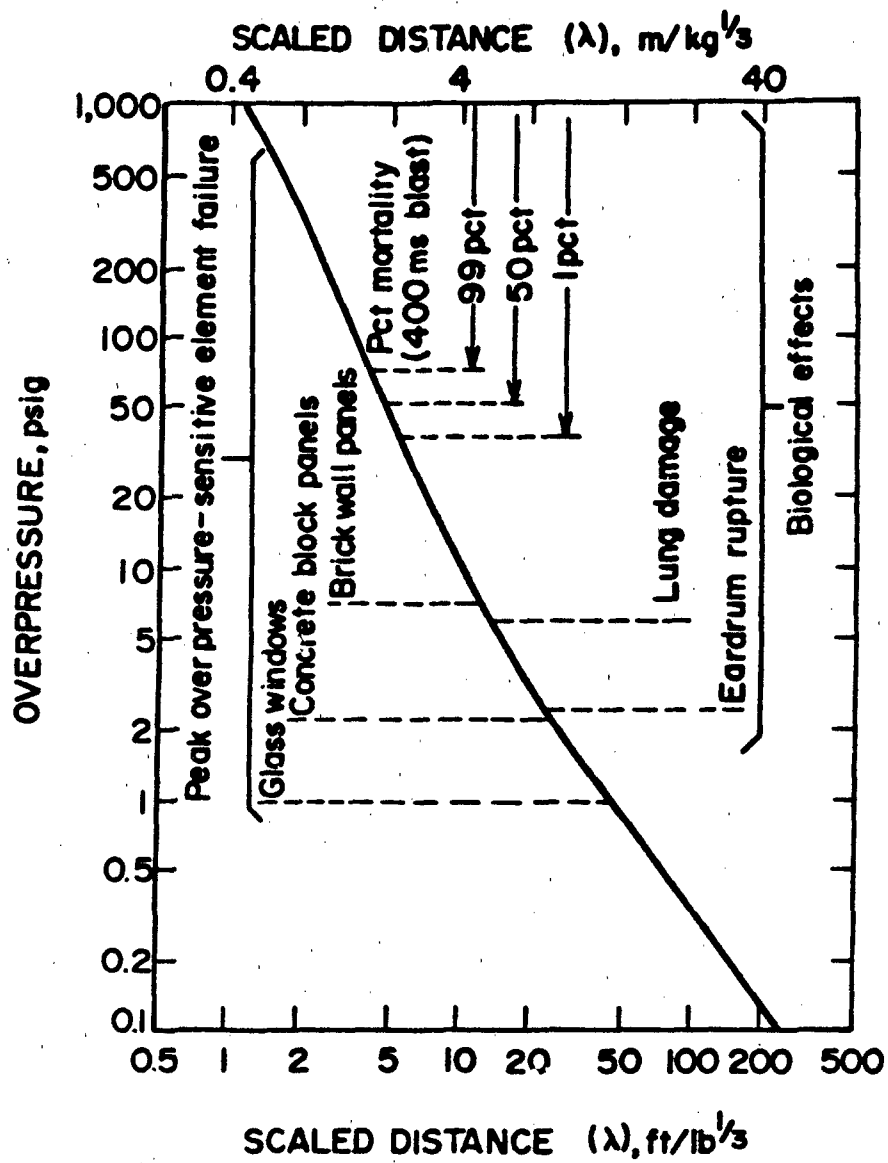

Figure 63. Peak Overpressure vs. Scaled Distance with Approximate Biological and Material Effects

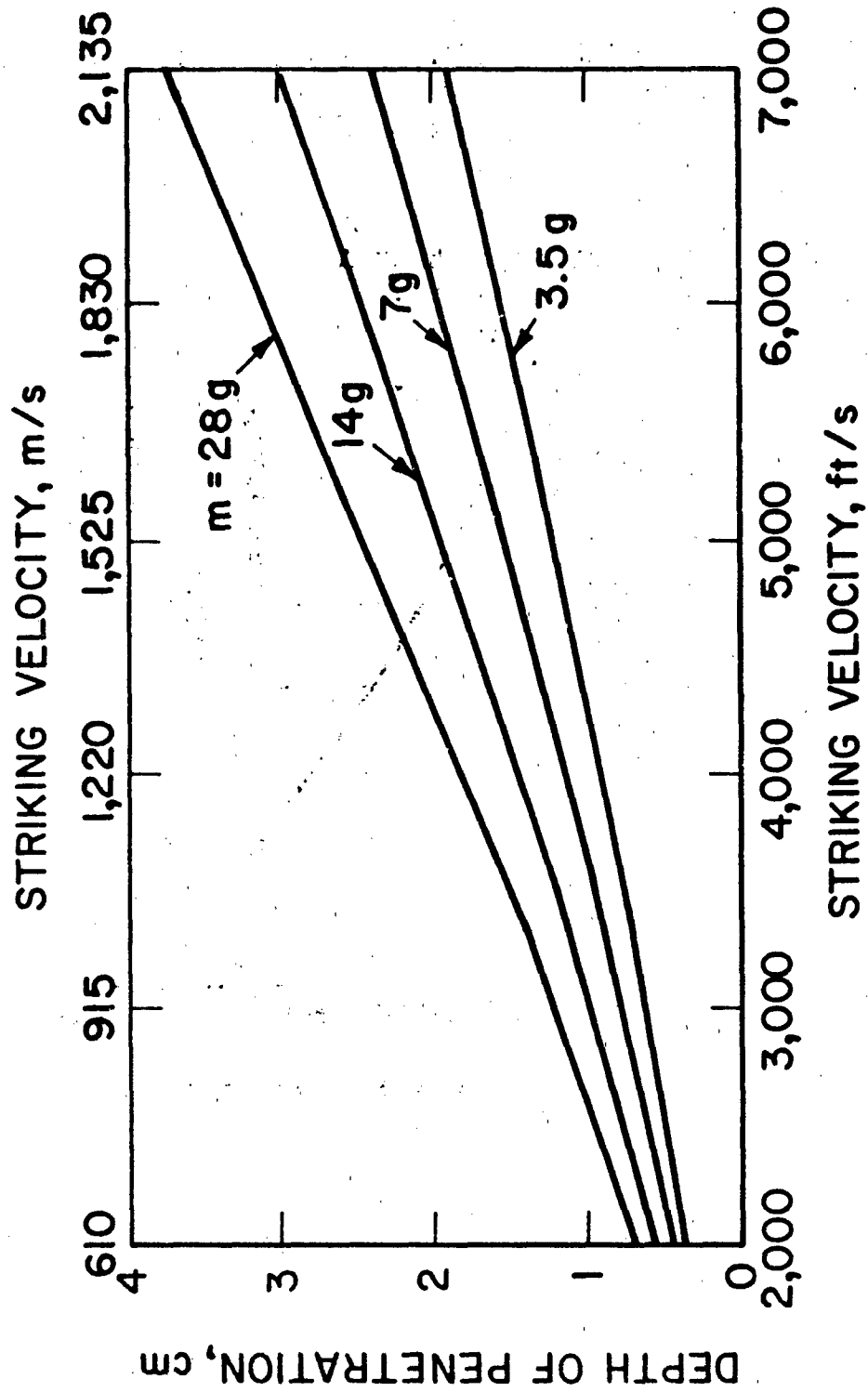

Figure 64. Depth of Penetration of Mild Steel vs. Striking Velocity for Steel Fragments of Various Weights (m)

**TABLE 39 THRESHOLD OVERPRESSURES FOR BIOLOGICAL DAMAGE
 BY PRESSURE PULSES OF SHORT DURATION (3-5 ms)***

Damage	Threshold Overpressure (psi)
Eardrum rupture	5 (~15 @ 50% probability)
Lung damage	30 - 37
Lethality	100-200

* Reference 67.

E. CRATER AND MISSILE DAMAGE CRITERIA

Ground craters can result from the violent impact of an aircraft as well as from the detonation of high explosives, such as those given in Table 23. By the cube root scaling law, the crater diameter (d) is given by

$$d = 1.5 W^{1/3} \tag{58}$$

where W is charge weight of equivalent TNT in pounds and d is in feet (Ref. 19). The crater depth is nominally 1/4 the crater diameter.

Missile damage from the fragmentation of a vessel will vary with the mass, shape, and velocity of the fragment and the nature of the target material. Approximately 10% of the available chemical energy (strong confinement) may be assumed for rupturing a vessel in a gaseous explosion (Ref. 68); also, about 20% of the chemical energy may be taken as the kinetic energy ($1/2 mv^2$) of the fragments. In practice, the pressure energy gives more realistic values for estimating the kinetic energies and velocities when the vessel shatters before maximum pressures are realized. The initial velocity (v_0) of an explosion fragment can be estimated from its distance from the explosion site (range, R) and application of equations of motion.

$$R = v_0^2 \sin 2\alpha / g \tag{59}$$

where R is maximum range, α is trajectory angle (45°), and g is gravitational constant (32 ft/sec.^2 or 980 cm/sec.^2). The corresponding maximum height (h) is

$$h = v_0^2 \sin^2 2\alpha / 2g \tag{60}$$

Air drag is neglected in equations 60 and 61.

A useful equation for predicting the penetration of irregular steel fragments into mild steel plates or similar targets is

$$P_d = k m^{1/3} \left(\frac{v}{1000} \right)^{4/3} \tag{61}$$

where k is 0.112 for mild steel and dimensions of the penetration depth (P_d , in), fragment weight (m, oz) and striking velocity (v, ft/sec.) are in the specified English units. Figure 64 (Ref. 69) shows predicted values by this

equation. The velocity range of 2-3,000 ft/sec. (~6-900 m/sec.) is comparable to the muzzle velocity of a 30-caliber rifle.

Human targets have low impact velocity thresholds for biological damage even with fragments of very low mass. Figure 65 (Ref. 66) compares blast-induced translational velocities of a 1/8-inch diameter nylon sphere with various velocity damage thresholds that can result from head or total body impacts. Of particular significance is that the threshold impact velocity is only about 15 ft/sec. (~4.5 m/sec.) for a skull fracture and 30 ft/sec. (~9 m/sec.) for a 100% lethal probability.

F. EXPLOSION-PROOF AND INTRINSICALLY SAFE ELECTRICAL EQUIPMENT

Since aircraft combustible vapor-air mixtures may be easily ignited by electrical sparks or arcs, every precaution must be taken to protect against the malfunctions of electrical systems. Accordingly, the electrical equipment and wiring on aircraft must meet the safety requirements specified in Air Force documents (see Reference section) and the National Electrical Code (Ref. 70). Some equipment may be classified as explosion proof in which case it will be capable of withstanding an internal gaseous explosion and preventing any external ignition by escaping hot gaseous products. Another category is intrinsically safe equipment. Such equipment or wiring is not capable of releasing sufficient electrical or thermal energy under normal or abnormal conditions to cause ignition of a fuel vapor - air mixture under ideal concentration conditions (Ref. 71). The limitations on the use of such equipment are defined relative to hazardous locations.

Article 500 of the National Electrical Code (NEC) divides hazardous locations into three classes:

- Class I - Flammable gases or liquid vapors
- Class II - Combustible dusts
- Class III - Ignitable fibers or flyings

Each class is subdivided as follows:

Class I - Division 1

- a. Location in which hazardous concentrations of flammable gases or vapors exist continuously, intermittently, or periodically under normal operating conditions; or
- b. In which concentrations of such gases or vapors may exist frequently because of repair or maintenance operations or because of leakage; or
- c. In which breakdown or faulty operation of equipment or processes might release hazardous concentrations of flammable gases or vapors, and might also cause simultaneous failure of electric equipment.

Class I, Division 2

- a. Location in which volatile flammable liquids or flammable gases are handled, processed, or used, but in which the hazardous liquids, vapors, or gases will normally be confined within closed containers or closed systems, from which they can escape only in case of accidental rupture or

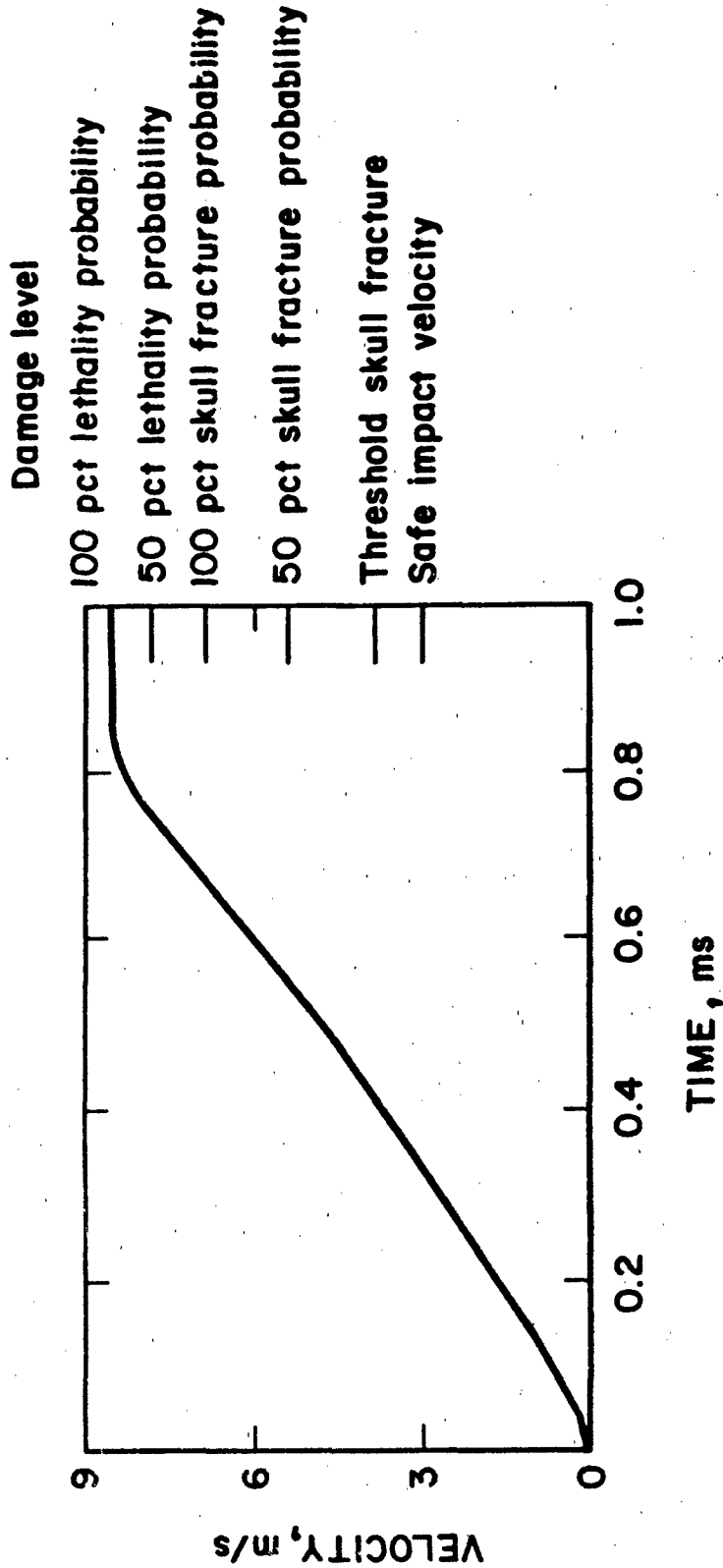

Figure 65. Velocity-time Profile and Potential Biological Damage Levels for Translation of 1/8 in. (0.32 cm) Diameter Nylon Sphere

breakdown of such containers or systems, or in case of abnormal operation of equipment; or

- b. In which hazardous concentrations of gases or vapors are normally prevented by positive mechanical ventilation, and which might become hazardous through failure or abnormal operation of the ventilating equipment; or
- c. Which is adjacent to a Class I, Division 1 location and to which hazardous concentrations of gases or vapors might occasionally be communicated unless such communication is prevented by adequate positive-pressure ventilation from a source of clean air and effective safeguards against ventilation failure are provided.

Class II - Division 1

- a. Location in which combustible dust is or may be in suspension in the air continuously, intermittently, or periodically under normal operating conditions in quantities sufficient to produce explosive or ignitable mixtures; or
- b. Where mechanical failure or abnormal operation of machinery or equipment might cause such explosive or ignitable mixtures to be produced and might also provide a source of ignition through simultaneous failure of electric equipment, operation of protection devices, or from other causes; or
- c. In which combustible dusts of an electrically conducting nature may be present.

Class II, Division 2

- a. Location in which combustible dust will not normally be in suspension in the air or will not likely be thrown into suspension by the normal operation of equipment or apparatus in quantities sufficient to produce explosive or ignitable mixtures, but
 - (1) Where deposits or accumulations of such combustible dust may be sufficient to interfere with the safe dissipation of heat from electric equipment or apparatus; or
 - (2) Where such deposits or accumulations of combustible dust on, in, or in the vicinity of, electric equipment might be ignited by arcs, sparks, or burning material from such equipment.

Class III, Division 1

- a. Location in which easily ignitable fibers or materials producing combustible flyings are handled, manufactured, or used.

Class III, Division 2

- a. Location in which easily ignitable fibers are stored or handled.

The equipment in question is approved not only for the class of location but also for the specific group of gas, vapor, or dust that will be present. These groups are summarized below.

Class I - Hazardous Location

Group A - Acetylene

Group B - Hydrogen, butadiene, ethylene oxide, or propylene oxide

Group C - Ethylene, acetaldehyde, cyclopropane, diethyl ether, isoprene, or UDMH

Group D - Paraffins, gasoline, acetone, alcohol, ammonia, benzene, ethylene dichloride, naphtha, natural gas, styrene, toluene, vinyl acetate, vinyl chloride, or xylenes

Class II - Hazardous Location

Group E - Metal dusts, including aluminum, magnesium, and commercial alloys

Group F - Carbon black, charcoal, coal, or coke dusts

Group G - Flour, starch, or grain dusts

Articles 500 through 503 of the NEC code require a form of construction of equipment and of installation that will ensure safe performance under conditions of proper use and maintenance. Of particular interest in aircraft applications are the equipment requirements for hazardous atmospheres (Group A, B, C, or D) in Class I locations. For example, any explosion-proof enclosure for the JP-4 jet fuel should be safe up to the maximum explosion pressure, maximum experimental safe gap (flange quenching gap), and ignition temperature associated with Group D flammable atmospheres. The temperature limitation for Group D is 280°C (536°F). Safety requirements for various electrical equipment are given in Reference 70.

In the case of intrinsically safe equipment, one usually is concerned with low-powered devices, such as instrumentation for monitoring or controlling a process. A hazard evaluation of such equipment or circuits can be made by comparing measured values of current, voltage, and associated inductances and capacitances with standard reference data for ignitions as given in NFPA 493 (Ref. 71). Figures 66 and 67 define minimum currents for ignitions of Class I hazardous atmospheres by resistance circuits with and without cadmium, zinc, or magnesium. Corresponding data for inductance and capacitance type circuits may be found in Reference 71.

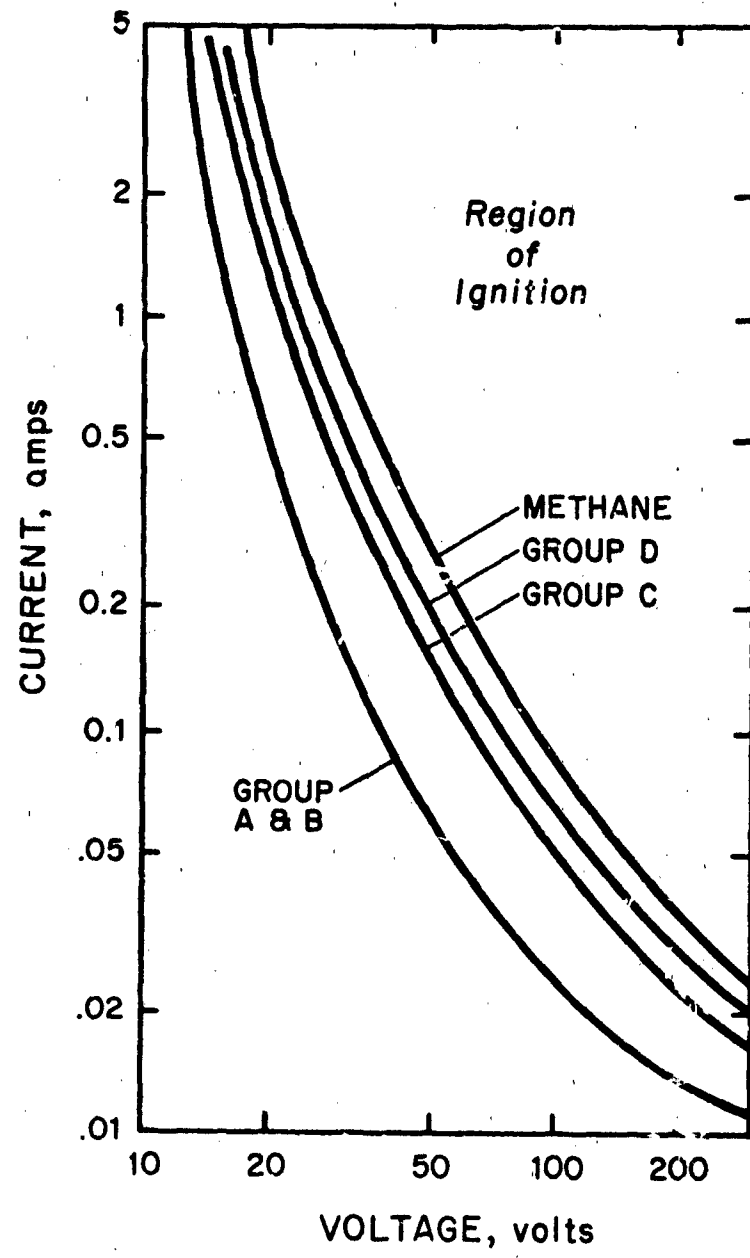

Figure 66. Minimum Ignition Current versus Voltage for Resistance Circuits (Inductance = 1 mH) in Class I Hazardous Locations: Circuits Containing Cadmium, Zinc, or Magnesium

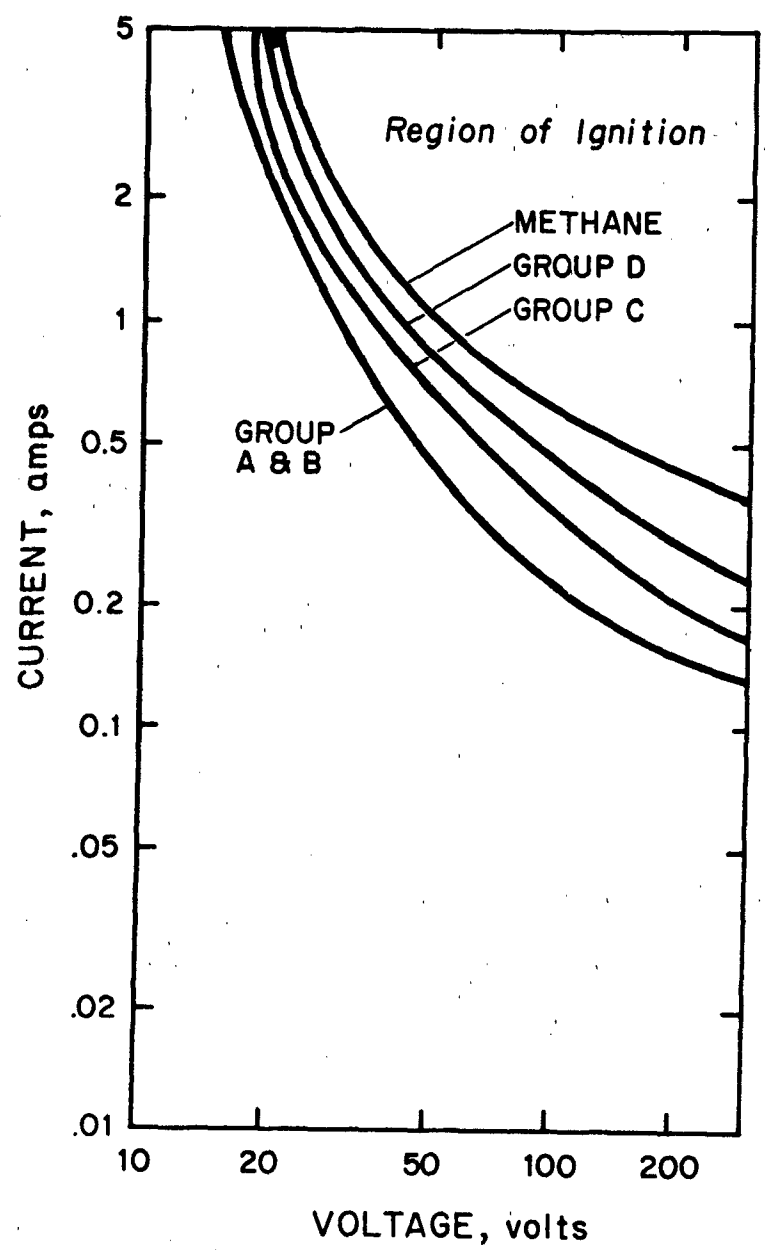

Figure 67. Minimum Ignition Current versus Voltage for Resistance Circuits (Inductance = 1 mH) in Class I Hazardous Locations: Circuits Not Containing Cadmium, Zinc, or Magnesium

XI. TOXICITY DAMAGE ANALYSIS

A. ASPHYXIATION

Most fatalities in aircraft fires result from asphyxiation. The asphyxiation may be attributable to insufficient oxygen, excessive concentrations of various gases such as carbon dioxide, interruption of breathing due to excessive heat, or a combination of these factors. The oxygen level at which a person may lose consciousness appears to be approximately 13% or lower, depending upon the exposure period (Table 40, Ref. 72).

TABLE 40 EFFECTS OF REDUCED OXYGEN CONCENTRATION
IN HUMAN RESPIRATION AT SEA LEVEL*

% Oxygen in Air	Effect
17	Faster, deep breathing
15	Dizziness, buzzing in ears, rapid heartbeat
13	May lose consciousness with prolonged exposure
9	Fainting, unconsciousness
7	Life endangered
6	Convulsive movements, death

* Ref. 72

An exposure period of the order of minutes can be very hazardous at an oxygen concentration of 6% (Table 41, Ref. 73). For the same exposure period, a carbon dioxide concentration of 50,000 ppm or a heated atmosphere of 284°F (140°C) presents a similar life hazard.

B. TOXIC FIRE GASES

Various toxic products can be evolved in the decomposition and combustion of organic materials. Toxic carbon monoxide and noxious carbon dioxide are the most common products. Other toxic gases can include ammonia, hydrogen cyanide, and nitrogen oxides, particularly with nitrogen containing materials; hydrogen chloride, hydrogen fluoride, hydrogen bromide, and carbonyl halides with halogenated hydrocarbons; and hydrogen sulfide and sulfur oxides with sulfur containing materials.

Tables 41 and 42 summarize the toxicity thresholds of various toxic fire gases for different exposure periods. The threshold limit values (TLV) values in Table 42 represent threshold limit values for adverse effects after repeated long exposure periods (8 hrs/day); therefore, they are of least importance in

TABLE 41 TOLERANCE OF SELECTED COMBUSTION PRODUCTS*

Combustion Products	Hazardous Levels for Times Indicated			
	Minutes	1/2 hr.	1-2 hrs.	8 hrs.
Heat (°F)	284	212	150	120
Oxygen (%)	6	11	14	15
Carbon Dioxide (ppm)	50,000	40,000	35,000	32,000
Carbon Monoxide (ppm)	3,000	1,600	800	100
Sulfur Dioxide (ppm)	400	150	50	8
Nitrogen Dioxide (ppm)	240	100	50	30
Hydrogen Chloride (ppm)	1,000	1,000	40	7
Hydrogen Cyanide (ppm)	200	100	50	2

* Reference 73; ppm = parts per million.

TABLE 42 TOXICOLOGY OF SOME HIGHLY TOXIC FIRE GASES*

Gas	TLV ppm	Dangerous 0.5 to 1 hr. ppm	Fatal 0.5 to 1 hr. ppm
CO	50	1,500-2,000 (1 hr.)	4,000
NO	-	100-150	400-800
NO ₂	5	-	-
HCl	5	1,000-2,000**	4,350
Cl ₂	1	50**	1,000**
COCl ₂	0.1	12.5	25 (0.5 hr.)
HF	3	50-250**	-
H ₂ S	10	400-700	800-1,000
HCN	10	400-700	100-200
NH ₃	50	2,500-6,500 (0.5 hr.)	5,000-1,000

* Reference 74.

** Brief exposure.

TLV - Threshold limit value

REFERENCES

1. Kuchta, J. M., Fire and Explosion Manual for Aircraft Accident Investigators, Air Force Aero Propulsion Laboratory, Tech. Report AFAPL-TR-73-74, August 1973.
2. U. S. Air Force, Investigating and Reporting U. S. Air Force Mishaps, AFR 127-4.
3. Federal Aviation Administration, Aircraft Accident Investigation and Reporting, Handbook 8020.1A, September 1968.
4. National Fire Protection Association, Aircraft Fire Investigators Manual, Proposed NFPA No. 422M, 1972.
5. International Civil Aviation Organization, Manual of Aircraft Accident Investigation, Doc. 6920-AN/855/4, 1970.
6. National Fire Protection Association, Fire Protection Handbook, 14th Edition, Boston, Massachusetts, 1977.
7. Handbook of Chemistry and Physics, Chemical Rubber Company, Cleveland, Ohio, 53rd Edition, 1972-1973.
8. Keenan, J. H., and J. Kaye, Gas Tables, 2nd Printing, John Wiley and Sons, Inc., New York, New York, 1949.
9. Coordinating Research Council, Handbook of Aviation Fuel Properties, CRC Report No. 530, 1983.
10. Kuchta, J. M., Summary of Ignition Properties of Jet Fuels and Other Aircraft Combustible Fluids, Air Force Aero Propulsion Laboratory, AFAPL-TR-75-70, September 1975.
11. Beery, G. T., R. G. Clodfelter, et al., Assessment of JP-8 as a Replacement Fuel for the Air Force Standard Jet Fuel JP-4, Part I, Air Force Aero Propulsion Laboratory, Tech. Report AFAPL-TR-74-71, June 1975.
12. Zabetakis, M. G., Flammability Characteristics of Combustible Gases and Vapors, U. S. Bureau of Mines, Bulletin 627, 1965.
13. Jones, G. W., M. G. Zabetakis, et al, Research on Flammability Characteristics of Aircraft Fuels, WADC Tech. Report 52-35, 1952.
14. Zabetakis, M. G., G. W. Jones, G. S. Scott, and A. L. Furno, Research on Flammability Characteristics of Aircraft Fuels, WADC Tech. Report 52-35, Supplement 4, 1956.
15. Supplement I of Reference 13, 1954.
16. Coward, H. F. and G. W. Jones, Limits of Flammability of Gases and Vapors, U. S. Bureau of Mines, Bulletin 503, 1952.

REFERENCES
 (Continued)

17. Barnett, H. C. and R. R. Hibbard, Properties of Aircraft Fuels, Lewis Flight Propulsion Center, NACA TN 3276, August 1956.
18. Lewis, B. and G. VonElbe, Combustion, Flames and Explosions of Gases, 2nd Edition, Academic Press, Inc., New York, 1961.
19. Van Dolah, R. W. and D. S. Burgess, Explosion Problems in the Chemical Industry, American Chemical Society, 1970.
20. Guide to the Use of Flame Arrestors and Explosion Reliefs, Ministry of Labour, New Series No. 34, H. M. Stationery Office, 423 Oxford Street, London, WI, August 1965.
21. Stack, C. and D. C. Woodhead, Correlation of Ignitabilities of Gases and Vapors by Break Spark and a Flange Gap, Proc. Inst. Elect. Engr., Volume 113, No. 2, 1966.
22. Zabetakis, M. G., A. L. Furno, and J. J. Miller, Research on the Flammability Characteristics of Aircraft Hydraulic Fluids, WADC Tech. Report 57-151, Part I, 1957; Part II, 1959.
23. Kuchta, J. M., S. Lambiris, and M. G. Zabetakis, Flammability and Auto-ignition of Hydrocarbon Fuels under Static and Dynamic Conditions, U. S. Bureau of Mines RI 5992, 1962.
24. Parts, L., Assessment of the Flammability of Aircraft Hydraulic Fluids, Air Force Aero Propulsion Laboratory, Tech. Report AFAPL-TB-79-2055, July 1979.
25. Kuchta, J. M. and R. J. Cato, Hot Gas Ignition Temperatures of Hydrocarbon Fuel Vapor-Air Mixtures, U. S. Bureau of Mines RI 6857, 1966.
26. Bernstein, H. and G. G. Young, Striking Characteristics and Safety Hazards of Metallic Materials, NAVOR Report 5205, April 1957.
27. Andrews, G. E. and D. Bradley, The Burning Velocity of Methane-Air Mixtures, Combustion and Flame, Vol. 19, 1972.
28. Burgess, D. and M. G. Zabetakis, Fire and Explosion Hazards Associated with Liquefied Natural Gas, U. S. Bureau of Mines RI 6099, 1962.
29. Jacobson, J., A. R. Cooper, and J. Nagy, Explosibility of Metal Powders, U. S. Bureau of Mines RI 6516, 1964.
30. Chemical Engineers Handbook, Third Edition, McGraw Hill Book Company, New York, New York, 1950.
31. Grosse, A. V. and J. B. Conway, Combustion of Metals in Oxygen, Ind. Eng. Chem., Vol. 50, No. 4, April 1958.

REFERENCES
(Continued)

32. Plano, R. J., Tests Evaluate Fire Hazard of Static Sparks, Modern Hospital, Vol. 95, No. 154, September 1960.
33. Guest, P. G., Oily Fibers May Increase Oxygen Tent Fire Hazard, Modern Hospital, Vol. 104, No. 180, May 1965.
34. Huggett, C., et al, The Effects of 100% Oxygen at Reduced Pressure on the Ignitability and Combustibility of Materials, SAM-TR-65-78; Brooks Air Force Base, December 1965.
35. Lawson, D. I., and D. Hird, Radiation from Burning Buildings, Fire Office Committee, London Fire Protection Association, June 1953.
36. Reference 6, 1969 Edition (National Bureau of Standards data)
37. Jacobson, M., J. Nagy, and A. R. Cooper, Explosibility of Dusts Used in the Plastics Industry, U. S. Bureau of Mines, RI 5971, 1962.
38. Kuchta, J. M., A. L. Furno, and G. H. Martindill, Flammability of Fabrics and Other Combustibles in Oxygen-Enriched Atmospheres, Fire Technology, Vol. 5, August 1950.
39. Kuchta, J. M., and A. F. Smith, Classification Test Methods for Flammable Solids, U. S. Bureau of Mines RI 7593, 1972.
40. Van Dolah, R. W., M. G. Zabetakis, D. S. Burgess, and G. S. Scott, Review of Fire and Explosion Hazards of Flight Vehicle Combustibles, U. S. Bureau of Mines IC 8137, 1963.
41. Furno, A. F., A. C. Imhof, and J. M. Kuchta, Effect of Pressure and Oxidant Concentration on Autoignition Temperatures of Selected Combustibles in Various Oxygen and Nitrogen Tetroxide Atmospheres, Jour. Chem. Eng. Data, Vol. 13, No. 2, April 1968.
42. Lawrence Radiation Laboratory, Properties of Chemical Explosives, University of California, Livermore, California, AEC Contract No. W-7405-eng-48, Report No. UCRL-14952, 16 Dec. 1965.
43. Botteri, B. P., R. E. Cretcher, and W. R. Kane, Aircraft Applications of Halogenated Hydrocarbon Fire Extinguishing Agents, Symposium on an Appraisal of Halogenated Fire Extinguishing Agents, National Academy of Sciences, Washington, D.C., April 1972.
44. Geyer, G. B., Evaluation of Aircraft Ground Fire Fighting Agents and Techniques, Federal Aviation Administration, Report No. FAA-RD-71-57, February 1972.
45. Hilado, C. J., Flammability Handbook for Electrical Insulation, Chapter 2, Decomposition, Combustion, and Propagation.
46. Data provided by the Air Force AeroPropulsion Laboratory.

REFERENCES
(Continued)

47. Baumeister, T. and L. S. Marks, Standard Handbook for Mechanical Engineers, 7th Edition, 1969.
48. Perry, R. H., and C. H. Chilton (Editors), Chemical Engineers Handbook, McGraw-Hill Book Company, 5th Edition, New York, 1973.
49. Weast, R. C. (Editor), Handbook of Chemistry and Physics, Chemical Rubber Company, Cleveland, Ohio, 53rd Edition, 1972-73.
50. Economy, G., Heat Distress and Fire Patterns, USAF Safety Journal, March 1981.
51. Sarkos, C. P., Titanium Fuselage Environmental Conditions in Post-Crash Fires, Federal Aviation Administration, Report No. FAA-RD-71-3, March 1971.
52. Yumoto, T., Fire Spread Between Two Oil Tanks, Journal Fire and Flammability, Vol. 8, October 1977.
53. Kourtides, D. A., W. J. Gilwee, and J. A. Parker, Thermal Response of Composite Panels, Society of Plastics Engineers ANTEC Meeting, Washington, D.C., April 24-27, 1978.
54. High, R. W., The Saturn Fireball, Annapolis, New York Academy of Sciences, Vol. 152, 1, 1968.
55. Johnson, A. L., A. L. Furno, and J. M. Kuchta, Infrared Spectral Radiances and Explosion Properties of Inhibited Methane-Air Flames, U. S. Bureau of Mines R.I. 8246, 1977.
56. Botteri, B. P., R. G. Clodfelter, J. R. Manheim, and E. E. Ott, Evaluation of JP-8 vs. JP-4 Fuel for Enhancement of Aircraft Combat Survivability, Air Force Aero Propulsion Laboratory, Tech Memo APFH-TM-70-34, June 1970.
57. Kuchta, J. M., R. J. Cato, I. Spolan and W. Gilbert, Evaluation of Flame Arrestor Materials for Aircraft Fuel Systems, Air Force Aero Propulsion Laboratory, Tech Report, AFAPL-TR-67-148, February 1968.
58. Rasbash, D. J., Explosions in Domestic Structures, The Structural Engineer, Vol. 47 (10), October 1969.
59. Cousins, C. W., and P. E. Cotton, Design Closed Vessels to Withstand Internal Explosions, Chem. Eng., August 1951.
60. Sapko, M., A. L. Furno, and J. M. Kuchta, Flame and Pressure Development of Large-Scale CH₄-Air-N₂ Explosions, U. S. Bureau of Mines R. I. 8176, 1976.

REFERENCES
(Continued)

61. Burgess, D. S., J. N. Murphy, N. E. Hanna, and R. W. Van Dolah, Large-Scale Studies of Gas Detonations, U. S. Bureau of Mines R.I. 7196, November 1968.
62. USAF, Missile and Space System Mishaps Investigation, Air Force Manual AFM 127-200, 1 February 1967.
63. Glasstone, S., The Effects of Nuclear Weapons, U. S. Atomic Energy Commission, April 1962.
64. Kingery, C. and B. Pannill, Peak Overpressure vs. Scaled Distance for TNT Surface Bursts (Hemispherical Charges), B.R.L. Memorandum Report 1518, Ballistic Research Lab, Aberdeen, Maryland, 1964.
65. Filler, W. S., J. M. Rossi, and H. R. J. Walsh, Barricade Effectiveness Evaluated from Records of Accidental Explosions, Armed Services Explosives Safety Board Work Group, Report AD 487554L, July 1966.
66. Richmond, D. R., and C. S. White, Biological Effects of Blast and Shock, DASA-1777 Lovelace Foundation, April 1966.
67. Anon, Structures to Resist the Effects of Accidental Explosions, Dept. of Army Tech Manual TM-5-1300, Dept. of Navy Publications NAV FACP-397, Dept. of Air Force Manual AFM 88-22 (Change 1), June 1969.
68. High, W. G., Design and Scale Model Testing of a Cubicle to House Oxidation or High Pressure Equipment, Chem. & Ind., June 1967.
69. Peters, J., Blast and Fragmentation Characteristics, Prevention and Protection Against Accidental Explosions of Munitions, Fuels, and Other Hazardous Materials, Annals of the New York Academy of Sciences, Vol. 152, Article 1, October 1968.
70. National Fire Protection Association, National Fire Codes, Vol. 6, NFPA 70, National Electrical Code, 1978.
71. National Fire Protection Association, National Fire Codes, Vol. 4, NFPA 493 Intrinsically Safe Apparatus, 1975.
72. Hartman, H. L., Mine Ventilation and Air Conditioning, John Wiley and Sons, New York, 1982.
73. Yuill, C. H., Physiological Effects of Products of Combustion, Am. Soc. of Safety Engineers Journal, Vol. 19, 1974.
74. Wagner, J. P., Survey of Toxic Species Evolved in the Pyrolysis and Combustion of Polymers, Fire Research Abstracts and Reviews, Vol. 14, 1972.

AIR FORCE DOCUMENTS CONTAINING FIRE SAFETY CRITERIA

AFSC DH-1-6 System Safety

AFSC DH-2-2 Crew Stations and Passenger Accommodations

AFSC DH 2-3 Propulsion and Power

MIL-STD-882 System Safety Program for Systems and Associated Subsystems and Equipment: Requirements for

MIL-I-83294 Installation Requirements, Aircraft Propulsion Systems, General Specification for

MIL-E-5007 Engines, Aircraft, Turbojet and Turbofan, General Specification for

MIL-F-38363 Fuel System, Aircraft, Design, Performance, Installation, Testing, and Data Requirements, General Specification for

MIL-H-5440 Hydraulic Systems, Aircraft, Types I and II, Design, Installation, and Data Requirements for

MIL-W-5088 Wiring, Aircraft, Installation of

MIL-F-7872 Fire and Overheat Warning Systems, Continuous, Aircraft: Test and Installation of

MIL-D-27729 Detecting Systems; Flame and Smoke, Aircraft and Aerospace Vehicles, General Performance, Installation and Test of

MIL-E-22285 Extinguishing System, Fire, Aircraft, High-Rate-Discharge Type, Installation and Test of

TO 00-25-172 Ground Servicing of Aircraft and Static Grounding/Bonding

AIR FORCE MANUALS/REGULATIONS/HANDBOOKS

AFM 127-1 Aircraft Accident Prevention and Investigation
AFM 127-2 USAF Accident/Incident Reporting
AFR 127-4 Investigating and Reporting U. S. Air Force Accidents and Incidents
AFR 127-9 Life Sciences Investigation and Reporting of U. S. Air Force Aircraft Combat Mishaps
AFM 127-100 Explosive Safety Manual
AFM 127-101 Industrial Safety Accident Prevention Handbook
AFM 127-200 Missile and Space System Mishaps Investigation
AFM 127-201 Missile and Safety Handbook

AFSC Design Handbook DH 1-6 System Safety
AFSC Design Handbook DH 2-3 Propulsion and Power
AFSC Design Handbook DH 2-7 System Survivability

COMBUSTIBLES AND MISCELLANEOUS COMBUSTIBLES*

Combustible	Mol. Wt.	Specific Gravity (air=1)	Boiling Point OF	Vapor Pressure (70OF) psia	Heat Capacity		Net Heat of Combustion in Air Btu/lb.	Cet. Vol. %	Flash Point in Air OF	AIT in Air OF	Flammability Limits in Air	
					C _p (gas)	C _p (liquid)					L Vol. %	U Vol. %
Methane	16.04	0.55	-259	-	0.529	-	21,500	9.48	Gas	1,165	5.0	15.0
Ethane	30.07	1.04	-128	560	0.414	0.78	20,420	5.65	Gas	959	3.0	12.4
Propane	44.09	1.52	-44	124	0.393	0.58	19,930	4.02	Gas	871	2.1	9.5
n-Butane	58.12	2.01	31	33	0.402	0.58	19,670	3.12	Gas	761	1.8	8.4
n-Pentane	72.15	2.49	97	8.4	0.402	-	19,500	2.55	<-40	496	1.4	7.8
n-Hexane	86.17	2.98	156	2.5	0.403	0.60	19,240	2.16	-7	433	1.2	7.4
n-Octane	114.22	3.94	258	0.2	0.404	0.58	19,100	1.65	56	428	0.95	6.5
iso-Octane	114.22	-	211	0.80	0.404	-	19,080	-	10	779	1.1	6.0
n-Decane	142.28	4.91	345	0.03	0.405	0.5	19,020	1.33	115	406	0.75	5.6
Ethylene	28.05	0.97	-155	882	0.366	-	20,290	6.53	Gas	840	2.7	36
Propylene	42.08	1.45	-53	151	0.358	0.57	19,690	4.45	Gas	856	2.4	11
Acetylene	26.04	0.9	-118	645	0.399	-	20,740	7.72	Gas	580	2.5	100
Cyclohexane	84.16	2.91	179	1.55	0.304	-	18,680	2.27	-4	473	1.3	7.8
Benzene	78.11	2.69	176	1.5	0.245	0.406	17,270	2.72	12	1,040	1.3	7.9
Toluene	92.13	3.18	231	0.45	0.264	0.421	17,450	2.27	40	896	1.2	7.1
o-Xylene	106.16	3.67	292	0.1	0.295	0.411	17,610	1.96	90	887	1.1	6.4
Naphtha	-	2.5	95-140	-	-	-	-	-	<0	550	1.1	5.9
Turpentine	-	-	300	-	0.411	-	-	-	95	488	0.8	-
Methyl alcohol	32.04	1.11	147	1.85	-	0.600	8,580	12.25	52	725	6.7	36
Ethyl alcohol	46.07	1.59	173	0.85	-	0.581	11,550	6.53	55	689	3.3	19
Propyl alcohol	60.09	2.07	207	0.3	-	0.586	13,190	4.45	77	824	2.2	14
Ethylene glycol	62.07	-	387	0.0	-	0.573	7,340	-	232	752	3.2	-
Propylene glycol	76.09	-	270	-	-	-	9,350	-	210	700	2.6	12.5
Methylether	46.07	1.59	-11	-	-	-	12,340	6.53	-	662	3.4	27
Ethylether	74.12	2.56	95	8.7	-	0.547	14,560	3.37	-49	356	1.9	36
Acetone	58.08	2.01	0	3.6	-	0.528	12,280	4.97	0	869	2.6	13
Methylethylketone	72.10	2.49	21	-	-	0.549	13,490	3.67	21	960	1.9	10
Methyl acetate	74.08	2.56	14	3.3	-	0.468	8,700	5.65	14	935	3.2	16
Ethyl acetate	86.10	3.04	24	1.45	-	0.459	10,300	4.02	24	800	2.2	11
Carbon monoxide	28.0	0.97	-313	-	0.248	-	4,340	29.50	Gas	1,128	12.5	74
Hydrogen	2.02	0.07	-423	-	3.412	-	51,600	29.53	Gas	970	4.0	75
Ammonia	17.08	0.59	-28	129	0.940	-	8,000	21.83	Gas	1,204	15	28

* Reference 1.

APPENDIX B

Conversion Factors

To Convert From	To	Multiply By
Area		
Square centimeter	Square inch	0.155
Square inch	Square centimeter	6.452
Square inch	Square meter	6.452×10^{-4}
Square foot	Square inch	144
Square foot	Square meter	9.290×10^{-2}
Square yard	Square meter	0.836
Square yard	Square inch	1.296×10^3
Square mile	Square kilometer	2.590
Density		
Gram/cu. cm.	Pound/cu. foot	62.428
Ounce/cu. inch	Kilogram/cu. meter	1.730×10^3
Ounce/cu. foot	Kilogram/cu. meter	1.001
Kilogram/cu. meter	Gram/liter	1.000
Pound/cu. inch	Gram/cu. cm.	27.680
Pound/cu. inch	Kilogram/cu. meter	27.680×10^3
Pound/cu. inch	Pound/cu. foot	17.28×10^2
Pound/cu. foot	Kilogram/cu. meter	16.018
Energy or Work		
British thermal unit (Btu)	Joule (international)	1.055×10^3
British thermal unit	Calorie, gram	252.16
British thermal unit	Foot-pound	778
Calorie, gram	Joule	4.187
Erg	Dyne-cm.	1.000
Erg	Joule	1.00×10^{-7}
Foot pound	Joule	1.356
Foot pound	British thermal unit	1.285×10^{-3}
Foot poundal	Joule	4.214×10^{-2}
Horsepower-hour	British thermal unit	2.544×10^3
Kilocalorie	British thermal unit	3.968
Kilocalorie	Foot-pound	3.087×10^3
Kilocalorie	Kilogram-meter	4.27×10^2
Kilogram-meter	Foot-pound	7.233
Kilowatt-hour	Joule	3.600×10^6
Watt-second	Joule	1.000
Watt-hour	British thermal unit	3.413

APPENDIX B
 (Continued)

To Convert From	To	Multiply By
<u>Energy/Area-Time</u>		
Btu/sq.foot-min.	Watt/sq.inch	0.122
Btu/sq.foot-sec.	Watt/sq.meter	1.135×10^4
Btu/sq.foot-hr.	Watt/sq.meter	3.153
Calorie/sq.cm.-min.	Watt/sq.meter	6.973×10^2
Calorie/sq.cm.-sec.	Btu/sq.foot-sec.	3.690
Kilowatt/sq.foot	Btu/sq.foot-sec.	0.948
<u>Flow</u>		
Cu.foot/min.	Cu. meter/sec.	4.179×10^{-4}
Cu.foot/min.	Gallon (liquid)/sec.	0.125
Cu.foot/min.	Liters/sec.	0.472
Cu.inch/min.	Cu. meter/sec.	2.731×10^{-7}
Gallon (liquid)/min.	Cu. meter/sec.	6.309×10^{-5}
Pound/min.	Kilogram/sec.	7.560×10^{-3}
<u>Force</u>		
Dyne	Gram	1.02×10^{-3}
Dyne	Newton	1.00×10^{-5}
Gram (force)	Dyne	9.807×10^2
Kilogram (force)	Newton	9.807
Pound (force)	Newton	4.448
Pound (force)	Poundal	32.174
Poundal	Dyne	13.826×10^3
<u>Heat</u>		
Btu/hr.- sq.foot - °F	Watt/sq.meter - °K	5.678
Btu/sq.foot	Joule/sq.meter	1.136×10^4
Btu/pound - °F	Joule/kilogram - °K	4.187×10^3
Btu/pound	Joule/kilogram	2.326×10^3
Calorie/gram	Joule/kilogram	4.187×10^3
Calorie/sq.cm.	Joule/sq.meter	4.184×10^4
Calorie/sq.cm.-sec.	Watt/sq.meter	4.184×10^4
Calorie/cm.-sec.-°C	Watt/meter -°K	4.184×10^2
Sq.foot/hr. (thermal diffusivity)	Sq.meter/sec.	2.581×10^{-5}

APPENDIX B
 (Continued)

To Convert From	To	Multiply By
<u>Length</u>		
Centimeter	Inch	0.284
Centimeter	Angstrom	1.0×10^8
Centimeter	Micron	1.0×10^4
Foot	Meter	3.048×10^{-1}
Inch	Meter	2.540×10^{-2}
Meter	Centimeter	100
Meter	Inch	39.37
Meter	Feet	3.281
Meter	Yards	1.094
Micron	Meter	1.00×10^{-6}
Mile (statute)	Meter	1.609×10^3
Mile (statute)	Feet	5.280×10^3
Mile (statute)	Kilometer	1.609
Mile (nautical)	Meter	1.852×10^3
Yard	Meter	9.144×10^{-1}
Light year	Miles	5.90×10^{12}
<u>Mass</u>		
Gram	Ounce	3.53×10^{-2}
Ounce	Gram	28.35
Pound	Kilogram	45.36×10^{-2}
Ton (short, 2000 lb.)	Kilogram	9.072×10^2
Ton (long, 2240 lb.)	Kilogram	1.016×10^3
Slug	Pound	32.174
<u>Power</u>		
Btu/sec.	Horsepower	1.414
Btu/sec.	Watt	1.054×10^3
Calorie/sec.	Watt	4.184
Foot pound/sec.	Watt	1.356
Horsepower	Btu/hr.	2.545×10^3
Horsepower	Foot pound/sec.	550
Horsepower	Kilogram-meter/sec.	76.04
Horsepower	Watt	7.452×10^2
Horsepower (metric)	Watt	7.355×10^2
Watt	Joule/sec.	1.00
Kilowatt	Btu/sec.	9.483×10^{-1}
Kilowatt	Foot pound/sec.	7.376×10^{-2}
Kilowatt	Kilocalorie/sec.	0.239
Kilowatt	Horsepower	1.341
Kilowatt	Btu/hr.	3.414×10^3

APPENDIX B
 (Continued)

To Convert From	To	Multiply By
Pressure or Stress (Force/Area)		
Atmosphere (760 torr)	Cm. of mercury (0°C)	76.0
Atmosphere	Inches of mercury	29.921
Atmosphere	Feet of water	33.93
Atmosphere	Kilogram/sq. meter	10.332×10^3
Atmosphere	Pound/sq. foot	21.162×10^2
Atmosphere	Bar	1.013
Atmosphere	Pound/sq. inch	14.696
Atmosphere	Newton/sq. meter	1.013×10^5
Bar	Newton/sq. meter	1.00×10^5
Dynes/sq. cm.	Newton/sq. meter	1.00×10^{-1}
Inch of mercury	Pound/sq. inch	0.491
Inch of water	Pound/sq. inch	3.609×10^{-2}
Inch of water (60°F)	Newton/sq. meter	2.488×10^2
Pascal	Newton/sq. meter	1.00
Pound/sq. foot	Newton/sq. meter	1.488
Pound/sq. inch	Gram/sq. cm.	70.31
Pound/sq. inch	Pound/sq. foot	144.00
Pound/sq. inch	Newton/sq. meter	6.895×10^3
Torr (mmHg, 20°C)	Newton/sq. meter	1.333×10^2
Temperature		
Celsius (T_C , °C)	Fahrenheit (T_F , °F)	$T_F = 1.8(T_C) + 32$
Celsius (T_C , °C)	Kelvin (T_K , °K)	$T_K = T_C + 273$
Fahrenheit (T_F , °F)	Celsius (T_C , °C)	$T_C = (T_F - 32)/1.8$
Fahrenheit (T_F , °F)	Rankine (T_R , °R)	$T_R = T_F + 460$
Velocity		
Foot/sec.	Mile/hr.	6.818×10^{-1}
Foot/sec.	Meter/sec.	3.048×10^{-1}
Meter/sec.	Foot/sec.	3.281
Meter/sec.	Kilometer/hr.	3.600
Inch/sec.	Meter/sec.	2.540×10^{-2}
Mile/hr. (statute)	Meter/sec.	4.470×10^{-1}
Mile/hr. (statute)	Feet/sec.	1.467
Mile/hr. (statute)	Knots (nautical mile/hr.)	8.684×10^{-1}

APPENDIX B
 (Continued)

To Convert From	To	Multiply By
Viscosity		
Poise	Centipoise	100
Centipoise	Gram/cm.-sec.	1.00×10^{-2}
Centipoise	Pound/foot-sec.	6.720×10^{-4}
Centipoise	Newton-sec./sq.meter	1.00×10^{-3}
Centistoke	Sq.meter/sec.	1.00×10^{-6}
Stoke	Sq.cm./sec.	1.00
Stoke	Sq.inch/sec.	0.155
Volume		
Barrel (oil, 42 gal.)	Cu.meter	1.590×10^{-1}
Cu.cm.	Cu.inch	6.10×10^{-2}
Cu.feet	Cu.meter	2.832×10^{-2}
Cu.feet	Liter	28.316
Cu.feet	Cu.inch	1.728×10^3
Cu.feet	Gallon	7.481
Cu.inch	Cu.meter	1.639×10^{-5}
Cu.inch	Cu.cm.	1.639×10^{-1}
Cu.yard	Cu.meter	7.646×10^{-1}
Gallon (liquid), U.S.	Gallon (liquid), U.K.	8.327×10^{-1}
Gallon (liquid), U.S.	Liter	3.785
Liter	Cu. cm.	1.00×10^3
Liter	Cu. inch	61.025
Liter	Quart	0.946
Quart (liquid), U.S.	Cu.meter	9.464×10^{-4}
Quart (liquid), U.S.	Cu.inch	5.775×10^1

APPENDIX C

GLOSSARY OF TECHNICAL TERMS

Ablation - Removal of material by erosion, evaporation, or reaction for short-term protection against high temperatures.

Accelerant - Substance used to initiate and develop a fire. Flammable liquids are the most common accelerants.

Adiabatic Process - Physical or chemical process without the loss or gain of heat.

Anoxia - Strictly, absence of molecular oxygen in living tissue cells; often used to indicate reduction of the oxygen content of the blood below physiological levels.

Arrhythmia - Absence of rhythm, applied especially to any variation from the normal rhythm of the heart beat.

Asphyxia - Unconsciousness resulting from anoxia or hypoxia and increased carbon dioxide in blood and tissue. See suffocation.

Autoignition Temperature - Temperature at which a material ignites spontaneously in air or other oxidant at a specified pressure. Also, spontaneous ignition temperature.

Bladder Cell - Tank formed by a flexible bag which is contained in a rigid cavity.

Blast Pressure - Overpressure (side-on) and dynamic pressure of an explosion.

BLEVE - Boiling-liquid-expanding-vapor explosion that occurs when a pressure vessel with flammable liquid is heated and bursts.

Bonding - Permanent joining of metallic parts to form an electrically conductive path which will assure electrical continuity and capacity to conduct safely any current likely to be imposed.

British Thermal Unit (Btu) - Amount of heat required to raise the temperature of 1 pound of water 1°F.

Burn - Undergo combustion or effect of fire.

Burn Degree - Burns of the first degree show hyperemia (redness); of the second degree, vesication (blistering); of the third degree, necrosis of skin and underlying tissues (charring).

Burning Rate - Rate at which a solid or liquid is burned, measured in the direction normal to the surface. Also, regression rate.

Burning Velocity - Rate at which a combustion wave propagates into unburned gas. For premixed flames, the velocity depends only on the initial conditions in the cold gas (temperature, pressure, and composition). Also, burning rate, flame velocity, and propagation velocity.

Calorie - Amount of heat required to raise the temperature of 1 gram of water 1°C.

Calorific Value - Heating value or heat of combustion of a combustible material in oxygen.

Carboxyhemoglobin - Product of reaction between hemoglobin and carbon monoxide.

Combustible - Capable of burning. In fire practice, the term usually refers to materials that will burn under normal conditions.

Combustible Liquid - Liquid having a flash point at or above 100°F according to NFPA classification code.

Combustion - Rapid oxidation or other chemical reaction of a material which produces heat and luminous or nonluminous burning.

Conflagration - Fire of large extent.

Cool Flame - Weak luminous hydrocarbon flame (e.g., <500°C) of fuel-rich air mixture. The chemistry involves peroxy radicals and is related to two-stage ignition.

Decomposition Flame - Flame of a combustible that can propagate without an oxidant.

Deflagration - Subsonic gaseous combustion process propagating through unreacted material by conduction, convection and radiation, with flame front and reaction products traveling in opposite directions.

Detonation - Supersonic combustion process propagating into unreacted material with flame front or shock front and reaction products traveling in the same direction.

Diffusion Flame - Nonpremixed laminar flame, the propagation of which is governed by the interdiffusion of the fuel and oxidizer. A candle flame is a typical example.

Enthalpy - Heat content of a substance or system.

Equivalence Ratio - Ratio of combustible/oxidant concentration to the stoichiometric ratio for complete combustion.

Explosion - Rapid release of pressure or energy. Effect of a rapid exothermic combustion reaction occurring in an enclosed space, characterized by a catastrophic buildup of pressure and resulting shock wave.

Explosion Limit - Highest or lowest concentration of a flammable gas or vapor in air or oxygen that will propagate flame when ignited.

Explosion Pressure - Maximum pressure of explosion reaction at constant volume.

Explosion-proof Equipment - Equipment in an enclosure that is capable of withstanding an internal explosion of a specified gas or vapor and of preventing possible ignition of a surrounding flammable atmosphere.

Explosion Suppression - A method, device, or system to effectively extinguish an explosion.

Explosive - Substance capable of sudden high velocity reaction with the generation of high pressures. High energy explosives generate detonations.

Explosive Mixture - Combustible-oxidant mixture that is potentially explosive or capable of propagating flame.

Extinguishing Agent - Substance used to put out a fire by cooling the burning material, inhibiting chemical reaction and/or blocking the supply of oxygen.

Fire - Rapid oxidation or other reaction of fuel resulting in heat and light emission.

Fire Classes - For purposes of identification of hazards and to facilitate the control and extinguishment of fires, the NFPA classifies fires and hazards by type of fuel or combustible:

Class A - Ordinary combustibles such as wood, cloth, paper, rubber, and certain plastics.

Class B - Flammable or combustible liquids, flammable gases, greases, and similar materials.

Class C - Energized electrical equipment.

Class D - Combustible metals, such as magnesium, titanium, zirconium, sodium, or potassium.

Fire Load - Potential heat release of combustible materials in a given space, expressed in terms of Btu/sq.ft. (British thermal units per square foot) or, in the case of ordinary combustible materials such as wood and paper, in terms of lbs./sq.ft. (pounds per square foot). A fire load of less than about 80,000 Btu/sq.ft. (10 lbs./sq.ft.) is considered to provide a low fire severity in the space; 80,000-160,000 Btu/sq.ft. (10-20 lbs./sq.ft.), a moderate fire severity; and over 160,000 Btu/sq.ft. (over 20 lbs./sq.ft.) a high fire severity.

Fire Point - Lowest temperature at which a liquid gives off sufficient flammable vapor to produce sustained combustion after removal of the ignition source.

Fireproof - A condition in which structure, equipment, wiring, controls, or piping is capable of performing its intended function under the most severe conditions of fire likely to occur at its location.

Fire Resistance Rating - Length of time, in hours, that a building material or assembly (beam, girder, or truss; column, floor, or floor-ceiling; roof or roof-ceiling, or wall or partition) will withstand the effects of a standard fire exposure and meet specific conditions of acceptance, in accordance with the "Standard Methods of Fire Tests of Building Construction and Materials," ASTM E-119, U.L. 263 or NFPA 251.

Fire Retardant - Substance or treatment, such as monoammonium sulfate, that reduces the combustibility of a material.

Fire Stop - Fire resistance or noncombustible material or construction installed at appropriate intervals in concealed spaces to prevent or restrict the spread of fire or smoke through walls, ceilings, and the like.

Fire Suppression System - A method, device, or system to detect fire or ignition and to extinguish the fire in sufficient time to prevent aircraft structural damage and/or debilitation of personnel.

Fire Triangle - Three factors necessary for combustion: fuel, oxygen, and heat. NOTE: A fire tetrahedron has been proposed to account for chemical chain reaction in combustion processes.

Flame Front - Temperature and compositional microstructure associated with flames; plane along which combustion starts.

Flame Proofing - Surface treatment or impregnation of wood products, textiles, and other materials with fire-retardant chemicals.

Flame Propagation - Spread of flame from region to region in a combustible material, especially in a combustible vapor-air mixture.

Flame Resistant - Property of a material that does not conduct flame or continue to burn when an ignition source is removed.

Flame Retardant - Flame inhibiting chemical compound, such as inorganic salts, Lewis acids, or free radical inhibitors, used on surfaces as well as in bulk to reduce the flammability of a product or structure.

Flame Speed - Velocity of propagating flame measured relative to the observer.

Flame Spread Rate - Propagation velocity of flame over a surface of combustible material.

Flame Temperature - Intensity of heat of a flame. Maximum temperature of combustion products in constant pressure or constant volume reaction.

Flammability Limits - Maximum and minimum concentrations of combustible gas in air or oxygen that are capable of propagating flame at a specified temperature and pressure.

Flammable - Capable of burning with a flame. Easily ignited or highly combustible.

Flammable Liquid - According to NFPA, liquid that has a flash point below 100°F and a vapor pressure not exceeding 40 psia at 100°F.

Flashback - Propagation of a flame from an ignition source back to a supply of flammable gas or liquid.

Flash Fire - Fire that spreads with extreme rapidity.

Flash Point - Minimum temperature at which a liquid vaporizes sufficiently to form an ignitable mixture with air. NFPA has divided liquids into flash point classes; Class I is called flammable and Classes II and III combustible liquids:

Class I - Liquids having flash points below 37.8°C (100°F).

Class IA - Those having flash points below 22.8°C (73°F) and B.P. below 37.8°C.

Class IB - Those having flash point below 22.8°C and B.P. at or above 37.8°C.

Class IC - Those having flash point at or above 22.8°C and below 37.8°C.

Class II - Liquids having flash points at or above 37.8°C and below 60°C (140°F).

Class III - Liquids having flash points at or above 60°C.

Fuel Tank Inerting - A method or system utilizing noncombustible gases such as nitrogen to preclude flammable fuel and air mixtures, and thus prevent fire and explosion.

Glowing Combustion - Oxidation of solid material with light emission but without a visible flame.

Ground - Conducting connection, whether intentional or accidental, between an electrical circuit or equipment and the earth, or to some conducting body that serves in place of the earth; resistances <1 ohm acceptable for electrical hazards and <10⁶ ohms for electrostatic hazards.

Heat Capacity - Heat required to raise the temperature of a unit quantity of material one degree.

Heat of Combustion - Heat evolved in the complete combustion of a mole or unit mass of material.

Hot Gas Ignition Temperature - Lowest temperature required for ignition of a substance by a jet of hot gas in some specified environment.

Hot Spot - Particularly active part of a fire.

Hot Surface Ignition Temperature - Lowest temperature required for ignition of a substance by a hot surface in some specified environment.

Hypergolic - Ability of substances to ignite spontaneously when mixed with each other.

Hypoxia - Oxygen want or deficiency in living tissue.

Ignition - Initiation of combustion as evidenced by glow, flame or explosion.

Ignition Delay - Time to ignition from the instant reactions are mixed or exposed to heat.

Ignition Energy - Quantity of heat or electrical energy that must be absorbed by a substance to ignite in some specified environment.

Ignition Temperature - Lowest temperature at which a substance can sustain combustion in air or oxygen at a specified pressure.

Incandescence - Emission of light by a substance due to its high temperature.

Induction Period - Time required by combustibles before oxidation and burning can proceed independently of heat or energy input.

Inerting Agent - Inert substance like nitrogen or helium which can prevent formation of ignitable mixtures.

Inhibition - Reduction of a fire or flame by the introduction of a chemical which interferes with the flame reactions. Examples are freons and sodium bicarbonate.

Intrinsically Safe Electrical Equipment - Equipment and wiring that is not capable of releasing sufficient electrical or thermal energy under normal or abnormal conditions to cause ignition of a specific mixture of gas or vapor in air in its most easily ignited concentration (NFPA 493-1975).

Intumescent Paint - A coating applied as a paint to a surface to protect it from flame or heat; produces an insulating, fire-resistant foam upon exposure to heat.

Isothermal Process - Physical or chemical process without a temperature change.

Jet Fuels - Jet aircraft fuels can be classed as low or high volatility petroleum mixtures. The low volatility grades are typically kerosenes, such as Jet A-1, JP-8, and JP-5. The high volatility grades are blends of kerosene and aviation gasoline (Av gas) such as JP-4, Jet B, and AVTAG. Specific NATO designation, product description, commonly used nomenclature and applicable specifications are as follows:

<u>NATO Code Number</u>	<u>Product Description</u>	<u>Commonly Used Nomenclature</u>
F-34	Turbine Fuel, Aviation: Kerosene Type + Fuel System Icing Inhibitor	JP-8 ¹ , AVTUR ²
F-35	Turbine Fuel, Aviation: Kerosene Type	Jet A-1 ³ , AVTUR ⁴
F-40	Turbine Fuel, Aviation: Wide-cut Type	JP-4 ⁵ Jet B ³ , AVTAG ⁶
F-44	Turbine Fuel, Aviation: High Flash Type	JP-5 ⁵ , AVCAT ⁷

- | | |
|------------------|------------------|
| 1. Mil-T-83133 | 5. Mil-T-5624 |
| 2. D.Eng.RD 2453 | 6. D.Eng.RD 2454 |
| 3. ASTM D1655 | 7. D.Eng.RD 2452 |
| 4. D.Eng.RD 2494 | |

Kindling Temperature - The lowest temperature at which a substance ignites. Also, ignition temperature.

LC₅₀ - Calculated concentration, usually atmospheric, of a chemical that is expected to produce death in 50 percent of the biological specimens exposed; median lethal concentration.

LD₅₀ - Calculated dose of a chemical or other agent that is expected to produce death in 50 percent of the biological specimens exposed to it.

Limit Flame Temperature - Lowest temperature at which flame can be sustained by a combustible mixed with air; flame temperature of lower limit of flammability.

Limiting Oxygen Index (L.O.I.) - The lowest oxygen concentration in an oxygen-nitrogen mixture at which a substance will continue to burn by itself.

Lower Limit of Flammability - Lowest concentration of a flammable vapor or gas mixed with an oxidant (e.g., air) that will propagate flame at a specified temperature and pressure.

Mach Number - Ratio of the speed of a body to the speed of sound in the surrounding atmosphere.

Mass Fire - Fire involving many buildings or structures or a large forest fire.

Noncombustibility - Property of a material to withstand high temperature without ignition.

Nonflammable - Not liable to ignite or burn when exposed to flame.

Oxygen Index - Limiting oxygen index.

Physical Explosion - Explosions without any combustion or chemical reaction.

Preburn Time - Period between ignition and start of extinguishment (of fire).

Premixed Laminar Flame - Flame in which the fuel and oxidizer are mixed prior to combustion and the flow is laminar, e.g., Bunsen burner flame.

Pyrolysis - Irreversible chemical decomposition due to an increase in temperature without oxygen reaction.

Pyrophoric - Capable of autoignition upon contact with ambient air.

Quenching Distance (gap) - Minimum gap or wall separation distance below which ignitions of flammable mixtures are quenched in tubes or channels.

Radiation - Thermal or optical radiation (UV or IR) of the heat or fire source.

Ramp Fire - Any fire of an aircraft while it is on the ground, i.e., before takeoff or after successful landing and including when under construction or repair-maintenance-storage.

Rate of Heat Release - Amount of heat released by a burning body in unit time.

Reid Vapor Pressure - Vapor pressure of fluid at 100°F (38°C) in a bomb where initial liquid volume is $\sim 1/4$ the air volume.

Seat of Fire - Main body of a fire; fire area producing most of the heat.

Self-extinguishing - Incapable of sustained combustion in air after removal of external heat or flame.

Self-ignition - Ignition resulting from self or spontaneous heating. Also, spontaneous ignition.

Shock Wave Compression - Nonisentropic adiabatic compression in a wave traveling greater than local sound velocity.

Smoke - Fine (0.01 to 5 micron) dispersion in air of particles of carbon and other solids and liquids of incomplete combustion.

Smoldering - Combustion without flame but usually with incandescence and moderate smoke.

Smother - To extinguish a fire by blocking the oxygen supply or limiting it to a point below that required for combustion.

Specific Heat - Heat capacity of a substance per unit mass.

Spontaneous Combustion - Combustion of a substance through slow oxidation or other self-heating at ambient temperature.

Spontaneous Heating - Self-heat buildup by oxidation or fermentation. May lead to spontaneous ignition.

Spontaneous Ignition - Initiation of combustion of a material by spontaneous heating or by exposure to elevated temperature.

Stoichiometric Mixture - Mixture of combustible and oxidant for complete combustion.

Suffocation - Interference with the entrance of air into the lungs and resultant asphyxia.

Synergism - Combined action or effect of two or more agents that is greater than the sum of their individual actions.

TNT Equivalent - Energy release of a system expressed as an equivalent mass of TNT with an assumed heat of detonation of 1100 cal./g.

Temperature Limits of Flammability - Extreme limits of temperature within which saturated fuel vapor-air mixtures are flammable.

Threshold Limit Value (TLV) - Airborne concentration of a particular substance used to define conditions under which nearly all workers may be repeatedly exposed for a working lifetime (8 hours/day, 5 days/week) without adverse effect (value established by American Conference of Governmental Industrial Hygienists).

Toxicity - Harmful effect on a biological system caused by a chemical or physical agent.

Triboelectrification - Generation of static electricity by friction of flowing fluids and solids.

Turbulent Flame - Flame propagation under turbulent flow conditions. Example: jet engine flame.

Upper Limit of Flammability - The highest concentration of a flammable vapor or gas mixed with an oxidant (e.g., air) that will propagate flame at a specified temperature and pressure.