

AD A 132058

12



AFWAL-TR-83-4074

MECHANICAL PROPERTY EVALUATION OF P/M ALUMINUM
7090-T7E71 PLATE

John J. Ruschau
University of Dayton Research Institute
300 College Park Avenue
Dayton, Ohio 45469

August 1983

DTIC
SELECTE
SEP 2 1983
S B

Interim Report for Period June 1982-December 1982

DTIC FILE COPY

Approved for Public Release; Distribution Unlimited.

MATERIALS LABORATORY
AIR FORCE WRIGHT AERONAUTICAL LABORATORIES
AIR FORCE SYSTEMS COMMAND
WRIGHT-PATTERSON AIR FORCE BASE, OHIO 45433

88 08 20 052

NOTICE

When Government drawings, specifications, or other data are used for any purpose other than in connection with a definitely related Government procurement operation, the United States Government thereby incur no responsibility nor any obligation whatsoever; and the fact that the government may have formulated, furnished, or in any way supplied the said drawings, specifications, or other data, is not to be regarded by implication or otherwise as in any manner licensing the holder or any other person or corporation, or conveying any rights or permission to manufacture, use, or sell any patented invention that may in any way be related thereto.

This report has been reviewed by the Office of Public Affairs (ASD/PA) and is releasable to the National Technical Information Service (NTIS). At NTIS, it will be available to the general public, including foreign nations.

This technical report has been reviewed and is approved for publication.

David C Watson
DAVID C. WATSON
Engineering and Design Data
Materials Integrity Branch

Clayton Harmsworth
CLAYTON HARMSWORTH
Technical Manager
Engineering and Design Data
Materials Integrity Branch

FOR THE COMMANDER:

T J Reinhart
T. J. REINHART, Chief
Materials Integrity Branch
Materials Laboratory

"If your address has changed, if you wish to be removed from our mailing list, or if the addressee is no longer employed by your organization, please notify AFWAL/MLSE, W-PAFB, OH 45433 to help us maintain a current mailing list."

Copies of this report should not be returned unless return is required by security considerations, contractual obligations, or notice on a specific document.

UNCLASSIFIED

SECURITY CLASSIFICATION OF THIS PAGE (When Data Entered)

REPORT DOCUMENTATION PAGE		READ INSTRUCTIONS BEFORE COMPLETING FORM
1. REPORT NUMBER AFWAL-TR-83-4074	2. GOVT ACCESSION NO. AD A132 058	3. RECIPIENT'S CATALOG NUMBER
4. TITLE (and Subtitle) MECHANICAL PROPERTY EVALUATION OF P/M ALUMINUM 7090-T7E71 PLATE	5. TYPE OF REPORT & PERIOD COVERED Interim Technical Report June 1982-December 1982	
	6. PERFORMING ORG. REPORT NUMBER UDR-TR-83-19	
7. AUTHOR(s) John J. Ruschau	8. CONTRACT OR GRANT NUMBER(s) F33615-82-C-5039	
9. PERFORMING ORGANIZATION NAME AND ADDRESS University of Dayton Research Institute 300 College Park Avenue Dayton, Ohio 45469	10. PROGRAM ELEMENT, PROJECT, TASK AREA & WORK UNIT NUMBERS 62102F 2418-07-03	
11. CONTROLLING OFFICE NAME AND ADDRESS Materials Laboratory (AFWAL/MLSE) Air Force Wright Aeronautical Laboratories (AFSC) Wright-Patterson AFB, Ohio 45433	12. REPORT DATE August 1983	
	13. NUMBER OF PAGES 26	
14. MONITORING AGENCY NAME & ADDRESS (if different from Controlling Office)	15. SECURITY CLASS. (of this report) Unclassified	
	15a. DECLASSIFICATION/DOWNGRADING SCHEDULE	
16. DISTRIBUTION STATEMENT (of this Report) Approved for Public Release; Distribution Unlimited.		
17. DISTRIBUTION STATEMENT (of the abstract entered in Block 20, if different from Report)		
18. SUPPLEMENTARY NOTES		
19. KEY WORDS (Continue on reverse side if necessary and identify by block number) Powder-Metallurgy Fatigue 7090 Crack Growth Tensile Fracture		
20. ABSTRACT (Continue on reverse side if necessary and identify by block number) Mechanical property data were obtained for a single plate of powder-metallurgy (P/M) produced aluminum 7090-T7E71. Properties examined are tensile, compression, shear, bearing, smooth and notched fatigue, fatigue crack growth rate, and fracture toughness. Comparisons are made to other 7000-series ingot-metallurgy (I/M) produced aluminum alloys, more particularly, aluminum 7050. Results show the test material to be superior in strength, bearing, and shear properties than the majority of I/M 7000-series alloys. Improvements in both → (Continued)		

UNCLASSIFIED

SECURITY CLASSIFICATION OF THIS PAGE(When Data Entered)

20. Abstract (Concluded)

-smooth and notched fatigue resistance are also realized over I/M aluminums 7050 and 7075 in their respective corrosion resistant tempers. Toughness and fatigue crack growth rate properties are inferior to several I/M produced 7000-series structural aluminum alloys.

UNCLASSIFIED

SECURITY CLASSIFICATION OF THIS PAGE(When Data Entered)

PREFACE

This interim technical report was submitted by the University of Dayton Research Institute, Dayton, Ohio, under Contract F33615-82-C-5039, "Quick Reaction Evaluation of Materials," with the Air Force Wright Aeronautical Laboratories, Wright-Patterson Air Force Base, Ohio.

This effort was conducted during the period of June 1982 to December 1982. The author, Mr. John J. Ruschau, would like to extend special recognition to Messrs. Donald Woleslagle and John Eblin of the University of Dayton for performing all mechanical testing.

This report was submitted by the author in February 1983.

Accession	
NTIS	
DTIC	
Un	
Class	
By	
Distribution	
Availability Codes	
Dist	Avail and/or Special
A	

TABLE OF CONTENTS

<u>SECTION</u>		<u>PAGE</u>
I	INTRODUCTION	1
II	MATERIALS AND SPECIMENS	2
III	PROCEDURES	9
IV	RESULTS	11
	4.1 TENSILE	11
	4.2 COMPRESSION	11
	4.3 SHEAR	11
	4.4 BEARING	13
	4.5 FATIGUE	13
	4.6 TOUGHNESS	13
	4.7 FATIGUE CRACK GROWTH RATE	16
V	CONCLUSIONS	18
	REFERENCES	19

LIST OF ILLUSTRATIONS

<u>FIGURE</u>		<u>PAGE</u>
1	Cross-Section of 7090-T7E71 Plate (Concentrated NaOH Etch)	3
2	Tensile Specimen Geometry	5
3	Compression Specimen Geometry	5
4	Pin-Shear Specimen Geometry	6
5	Bearing Specimen Geometry	6
6	Smooth Fatigue Specimen Geometry	7
7	Notched Fatigue ($K_t=3$) Specimen Geometry	7
8	Compact Specimen Dimensions Used in Fracture and Fatigue Crack Growth Rate Investigations	8
9	Typical Bearing Failure for $e/D=1.5$ Specimens	14
10	Smooth and Notched Fatigue Results for P/M 7090-T7E71 Plate	15
11	Fatigue Crack Growth Rate Results for P/M Aluminum 7090-T7E71 Plate	17

LIST OF TABLES

<u>TABLE</u>		<u>PAGE</u>
1	Average Mechanical Properties of P/M Aluminum 7090-T7E71 Plate Material	12
2	Individual Plane-Strain Critical Toughness Values of 7090-T7E71 Plate, L-T Orientation	16

SECTION I INTRODUCTION

This report documents the results of a mechanical property investigation performed on aluminum 7090-T7E71 plate, a recently developed alloy produced via powder-metallurgy (P/M) techniques. This particular effort is part of an overall government-industry cooperative testing program, initiated by the Materials Laboratory of the Air Force Wright Aeronautical Laboratories (AFWAL), to generate mechanical property design data on several state-of-the-art P/M aluminum alloys. Participants in the cooperative program included aluminum producers and users, primarily those in the aerospace industry. The materials examined by the various participants were aluminums 7090 and 7091, both produced by Alcoa, and aluminum IN-9021, produced by Novamet. Each alloy was provided in various product forms (plate, forging, etc.).

To add to the data base, and to insure that each material is being examined by at least two independent sources, the Materials Laboratory has generated mechanical property data on aluminum 7090 plate. Properties examined in this effort were tensile, compression, bearing, shear, smooth and notched fatigue, fatigue crack growth, and fracture toughness.

SECTION II
 MATERIALS AND SPECIMENS

The test material was furnished by Alcoa in plate form, approximately 16 inches (406 mm) wide by 44 inches (1.1 m) in length. Originally, plate thickness to be examined in this cooperative test program was to be 0.25 inch (6.4 mm), but because of a coarse recrystallized surface grain structure that was caused by using small scale rolling procedures, the plate was furnished in a 0.4 inch (10 mm) thickness. This surface to center grain variation is illustrated in the photomicrograph shown in Figure 1. Since this recrystallized layer was estimated to be less than 0.075 inch (1.9 mm) thick, the middle 0.25 inch (6.4 mm) plate thickness is expected to be a good representative of aluminum 7090 should it reach a larger scale production. Therefore, all test specimens were removed from the center of the plate, keeping the actual test sections 0.25 inch (6.4 mm) thick or less.

A chemical analysis was performed on the test material, the results of which are shown below:

Zn	Mg	Cu	Co	Fe	Si	Aluminum
7.5	2.4	0.97	1.1	0.09	0.09	Balance

The composition is similar to other 7000 series alloys, with zinc as the primary alloying element, but is unique with the large addition of cobalt. The cobalt reportedly serves as a grain refiner, which also provides higher strength yet good corrosion resistance. Reference data^[1] indicates that increasing cobalt content also causes a decrease in toughness and ductility.

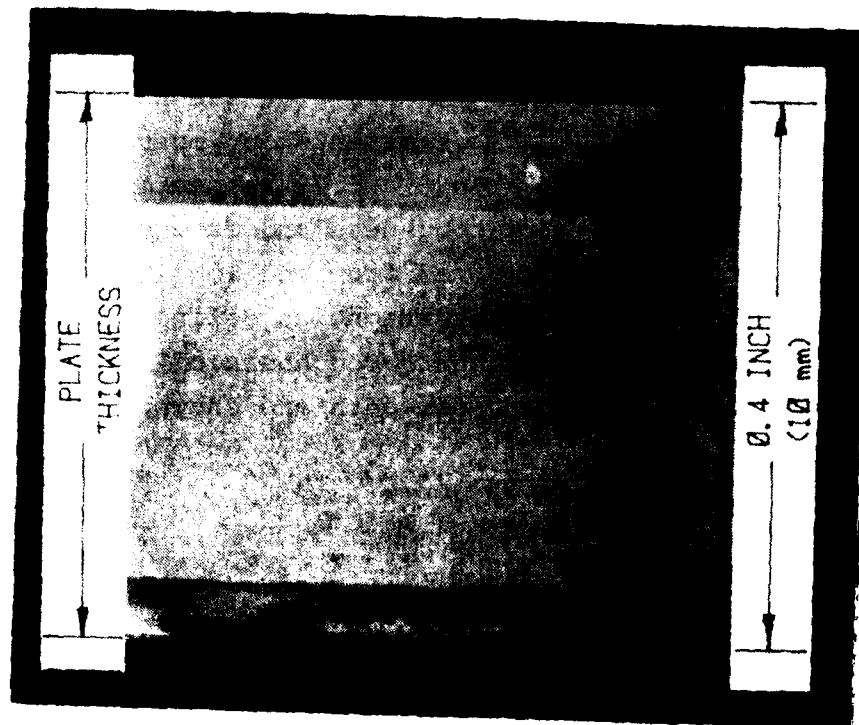

Figure 1. Cross-Section of 7090-T7E71 Plate (Concentrated NaOH Etch).

The plate material was furnished in the T7E71 temper, the heat treatment designed to give maximum strength for this alloy, yet maintain a good resistance to stress corrosion.

Tensile, compression, and pin-shear specimens were removed from both longitudinal and transverse orientations of the test plate and machined to the configurations shown in Figures 2, 3, and 4, respectively. Bearing specimens were likewise removed from both plate directions and machined in two edge/diameter (e/D) configurations per plate direction, as illustrated in Figure 5. Smooth and notched ($K_t = 3$) fatigue samples were removed from the longitudinal plate orientation only, and machined to the dimensions shown in Figures 6 and 7, respectively. Compact type specimens to evaluate both toughness and fatigue crack growth rate properties were machined from the longitudinal-transverse (L-T) crack-plane orientation, as defined in ASTM Standard E399, "Plane-Strain Fracture Toughness of Metallic Materials." Specimen dimensions for both are shown in Figure 8.

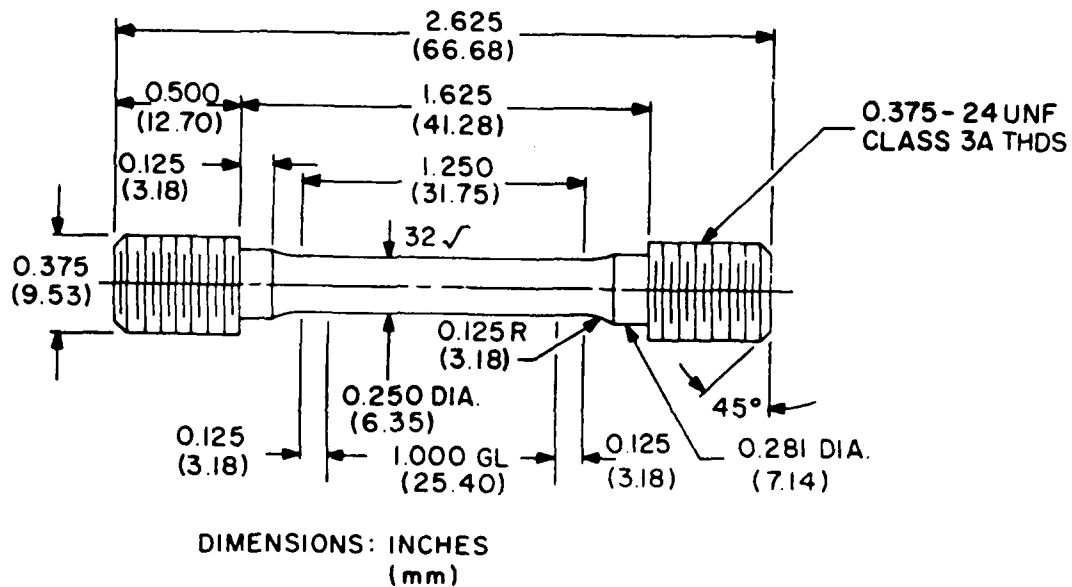

Figure 2. Tensile Specimen Geometry.

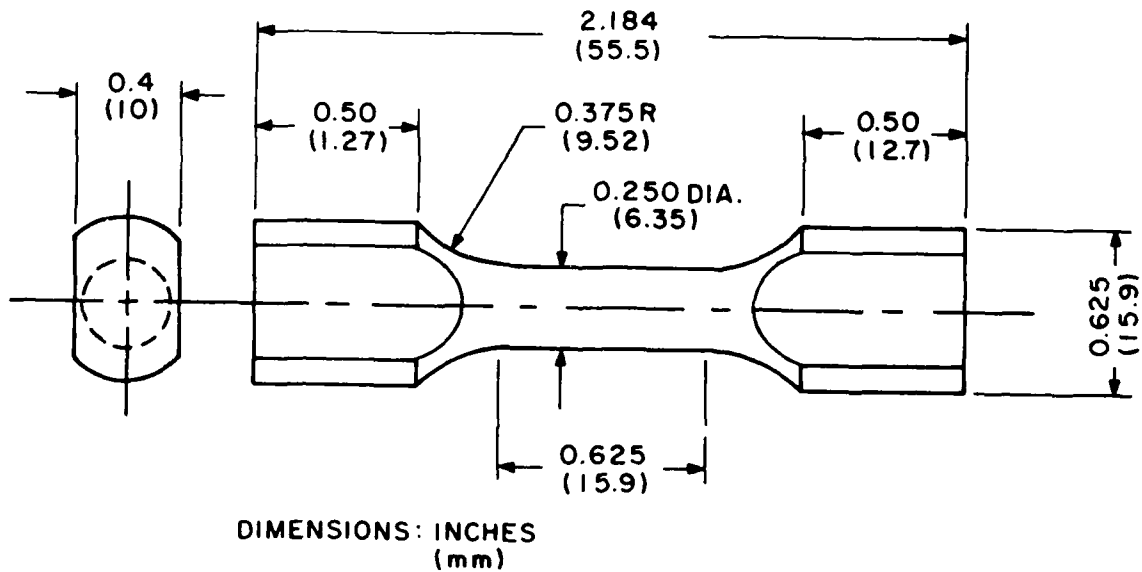

Figure 3. Compression Specimen Geometry.

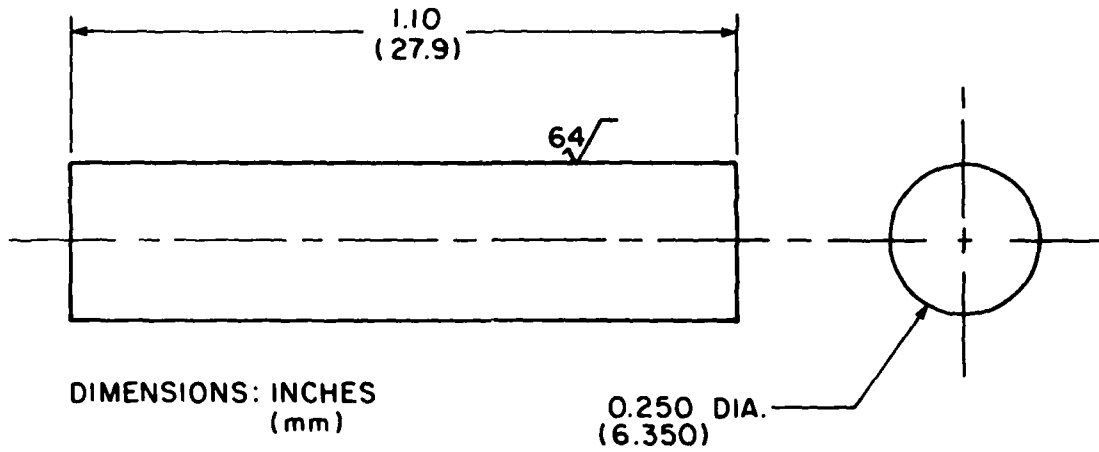
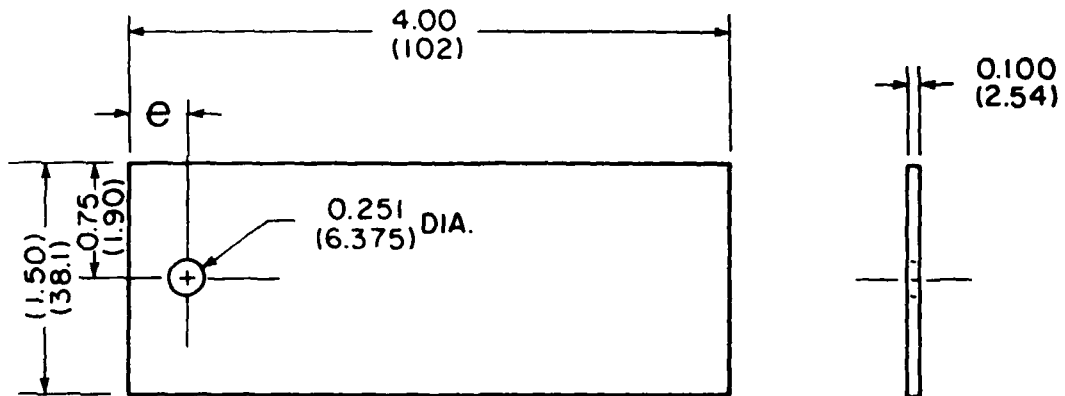

Figure 4. Pin-Shear Specimen Geometry.



e/D	e
1/2	0.375 (9.52)
2	0.500 (12.7)

Figure 5. Bearing Specimen Geometry.

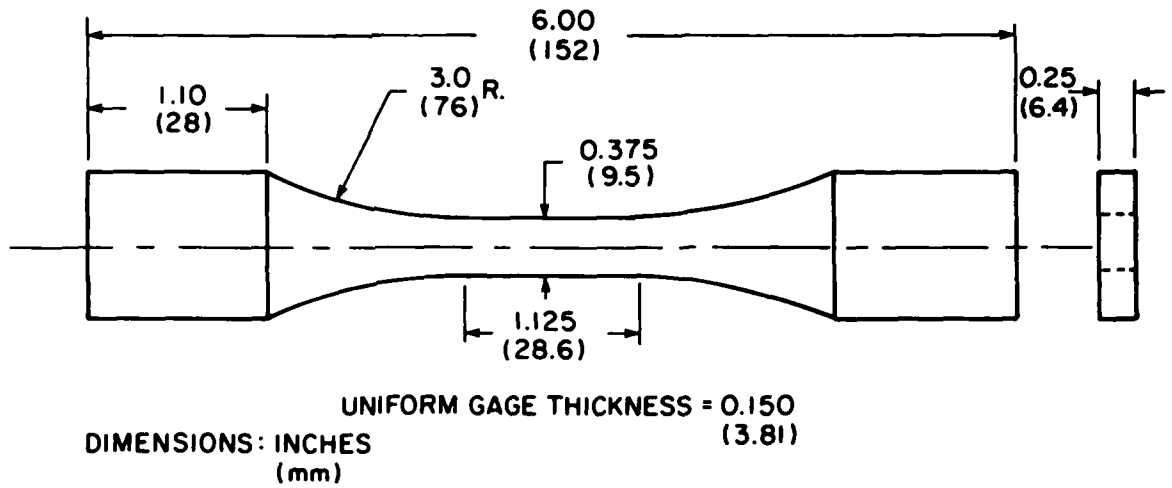

Figure 6. Smooth Fatigue Specimen Geometry.

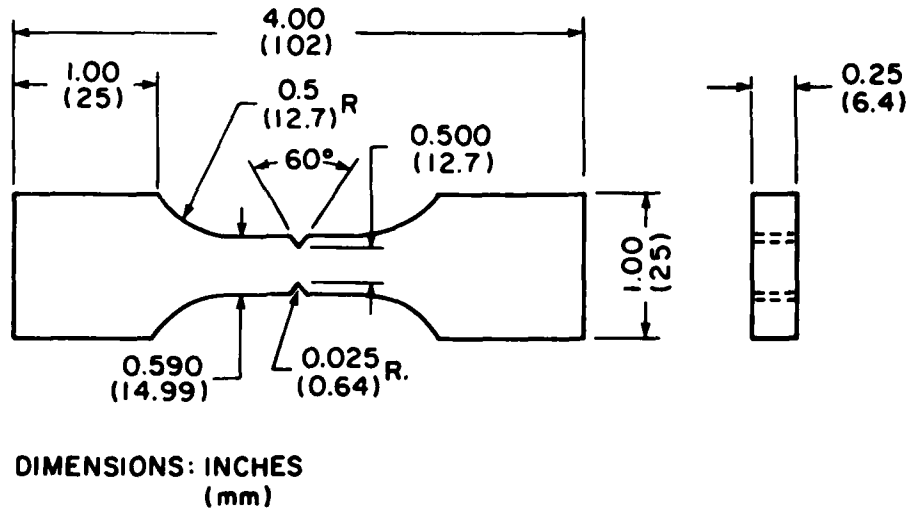
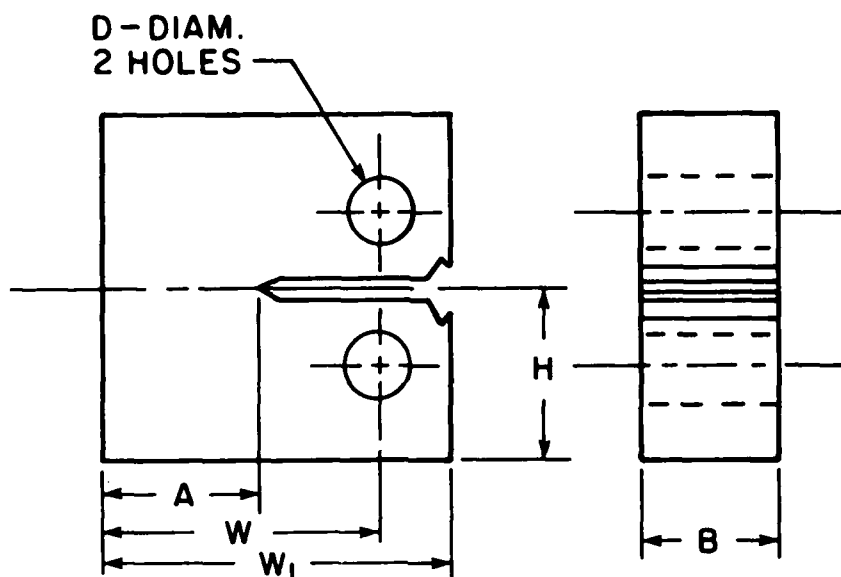

Figure 7. Notched Fatigue ($K_t=3$) Specimen Geometry.



DIMENSIONS

SPECIMEN TYPE	A	B	W	W ₁	H	D
FRACTURE	0.650 (16.5)	0.250 (6.35)	1.000 (25.4)	1.250 (31.8)	0.600 (15.2)	0.500 (12.7)
CRACK GROWTH	1.125 (28.6)	0.250 (6.35)	1.500 (38.1)	1.875 (47.6)	0.900 (22.9)	0.375 (9.52)

DIMENSIONS: INCHES
(mm)

Figure 8. Compact Specimen Dimensions Used in Fracture and Fatigue Crack Growth Rate Investigations.

SECTION III PROCEDURES

Tensile, shear, and bearing testing were performed on a 10 KIP (4.4 kN) Instron tensile testing machine. The appropriate ASTM test standards were adhered to when available. Tensile strain was obtained using an Instron 1-inch (25 mm) G.L. extensometer. For the bearing tests, both the specimen and bearing pin were carefully cleaned and degreased, as prescribed in ASTM E238, "Pin-Type Bearing Tests of Metallic Materials."

Compression testing was likewise performed in a 10 KIP (4.4 kN) Instron machine. A subpress was used to insure accurate, uniaxial compressive loading. A 0.5 inch (13 mm) G.L. microformer-type extensometer was used to monitor specimen strain.

Constant amplitude axial fatigue testing was accomplished using a 20 KIP (89 kN) capacity MTS hydraulic fatigue testing machine. Smooth fatigue specimens were hand-polished in the axial direction using aluminum polishing compound to insure no scratches existed perpendicular to loading direction. Notched fatigue specimens were polished in the notch region with the same polishing compound on a string. For all tests, a stress ratio (R) of 0.1 was maintained at 25 Hz, laboratory air conditions.

Fracture toughness properties were evaluated using procedures described thoroughly in ASTM Standard E399, "Plane-Strain Fracture Toughness of Metallic Materials." Testing was performed on a 60 KIP (267 kN) capacity Tinius Olsen tensile testing machine. Specimens were precracked to the appropriate initial crack size using an MTS hydraulic fatigue testing machine.

Constant amplitude fatigue crack growth rate testing was conducted in both a lab air (approx. 30 percent R.H.) and a high humidity (>90 percent R.H.) environment, in accordance with ASTM Standard E647, "Constant Load Amplitude Fatigue Crack Growth Rates Above 10^{-8} m/cycle." All testing was performed on a 2.5 KIP (11 kN) capacity MTS hydraulic fatigue testing

machine. Loading ratio (R) was 0.1 for a testing frequency of 25 Hz. Crack length was determined via a 10X Gaertner traveling microscope with digital readout. For the high humidity testing, an environmental chamber was constructed out of plexiglass, wherein humid air (moistened by bubbling through distilled water) was continually supplied throughout test duration. All raw crack growth data were reduced to final form using a seven-point incremental polynomial procedure, as outlined in the test standard.

SECTION IV RESULTS

4.1 TENSILE

Tensile properties determined for 7090-T7E71 plate are furnished in Table 1 for both longitudinal and transverse plate orientations. Slightly superior properties are seen in the transverse direction over the longitudinal in terms of both strength and ductility. These results reflect a noticeable increase in both yield (18 percent) and ultimate (10 percent) strength when compared to similar reference data^[2] on aluminum 7050-T73651 plate material. Ductility is approximately the same for both materials.

4.2 COMPRESSION

Average compression yield strength properties are also furnished in the table for both plate directions. Results indicate surprisingly high compressive yield strengths, higher than the tensile ultimate strengths in both directions. To substantiate these results, addition rectangular shaped compression samples were also removed from the remnant plate, approximately 0.25 inch (6.4 mm) thick, 0.62 inch (15.7 mm) wide, and 2.6 inches (66 mm) long. Using the same subpress, a Montgomery-Templin antibuckling fixture, and a Wiedemann tensile testing machine, identical compressive yield strengths were achieved, indicating the high values reported are indeed consistent.

4.3 SHEAR

Ultimate shear strength properties obtained on pin shear specimens from both plate directions are also furnished in Table 1. Similar to the tensile results, shear strengths are superior to most conventionally produced, structural aluminums, including the minimum specification ("S"-value) listed in MIL-HDBK-5 for aluminum 7050.

TABLE 1
 AVERAGE* MECHANICAL PROPERTIES OF P/M
 ALUMINUM 7090-T7E71 PLATE MATERIAL

	<u>KSI</u>	<u>(MPa)</u>
<u>Tensile:</u>		
Ultimate, L	87.5	(603)
T	89.5	(617)
Yield, L	82.6	(570)
T	85.1	(587)
% elong**, L	9.3	
T	12.2	
% R.A., L	24.0	
T	34.0	
<u>Compression:</u>		
Yield, L	87.6	(604)
T	94.3	(650)
<u>Shear:</u>		
Ultimate, L	48.9	(337)
T	47.8	(330)
<u>Bearing, Ultimate:</u>		
(e/D = 1.5), L	129.7	(894)
T	134.4	(927)
(e/D = 2.0), L	170.5	(1176)
T	179.8	(1240)
<u>Bearing, Yield</u>		
(e/D = 1.5), L	109.6	(756)
T	115.4	(796)
(e/D = 2.0), L	127.8	(881)
T	135.4	(934)

* - Properties listed are average of three tests.

** - 1.0 inch (25 mm) gage length.

4.4 BEARING

Average bearing strength properties determined at two edge-diameter ratios ($e/D = 1.5, 2.0$) for specimens oriented in both plate directions are likewise presented in Table 1. These bearing strength properties are approximately 20 percent greater than similar reference data on 7075-T73651 plate listed in MIL-HDBK-5 ("A"-values), and nearly 30 percent greater than the minimum specification ("S"-value) listed in the Handbook for 7050-T73651 plate. Consistent with the tensile data, bearing strength is slightly greater in the transverse direction than in the longitudinal. Typical fracture appearances of both longitudinal and transverse oriented specimens are illustrated in Figure 9. For all longitudinal specimens, failure was a clean, pure shear type pullout, while the transverse oriented samples underwent a combined shear/tensile type mode of failure.

4.5 FATIGUE

Both smooth and notched ($K_t = 3$) fatigue results for longitudinal oriented specimens are presented in Figure 10. Though the notched results fall in a well defined band, there is considerable scatter in the smooth fatigue data. Endurance stress, as defined at 10 million cycles, is approximately 43 and 17.5 KSI (296 and 120 MPa) for smooth and notched conditions, respectively. Reference data^[2] for 7050-T73651 tested under similar conditions indicate endurance strengths of 39 and 10 KSI (269 and 68.9 MPa) for stress concentrations of 1 and 3, respectively. Though this is a clear improvement over the conventionally produced 7050 material, it is below similar reference data^[3] for P/M 7091-T7E69, where smooth and notched fatigue strengths were 50 and 27 KSI (345 and 186 MPa), respectively.

4.6 TOUGHNESS

Individual fracture toughness test results are presented in Table 2. All three specimens tested yielded valid K_{IC}

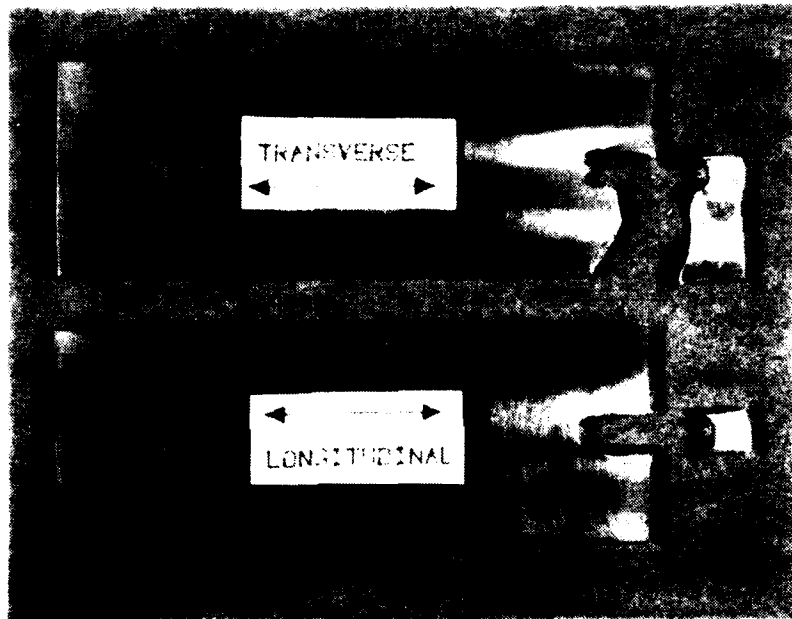

Figure 9. Typical Bearing Failure for $e/D=1.5$ Specimens.

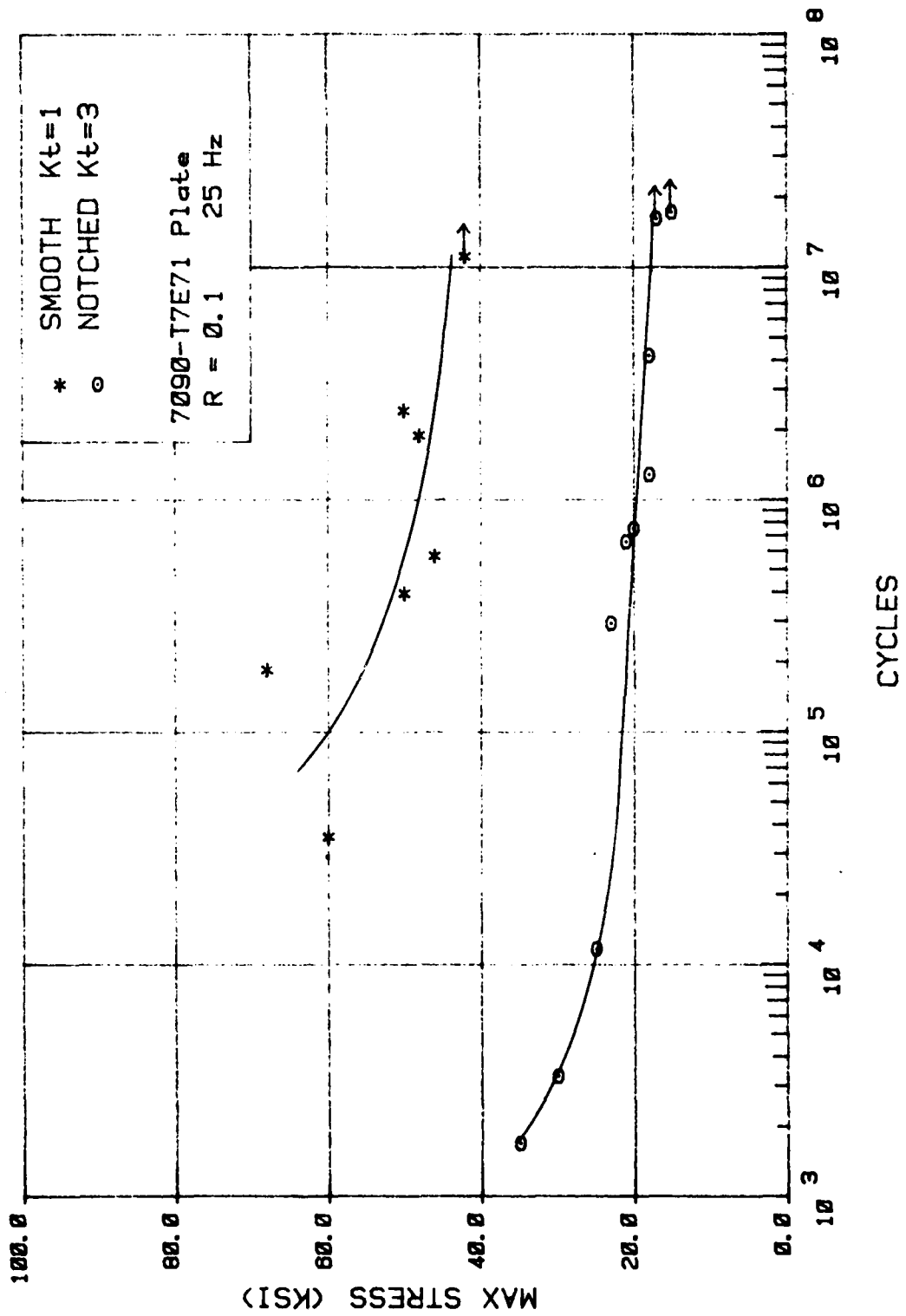

Figure 10. Smooth and Notched Fatigue Results for P/M 7090-T7E71 Plate.

TABLE 2
 INDIVIDUAL PLANE-STRAIN CRITICAL TOUGHNESS
 VALUES OF 7090-T7E71 PLATE, L-T ORIENTATION

Specimen No.	P_Q/P_{max}	K_{Ic} KSI \sqrt{in} (MPa \sqrt{m})	
1A	1.0	24.3	(26.7)
2A	1.0	23.5	(25.8)
3A	1.0	<u>26.1</u>	<u>(28.7)</u>
Avg.		24.6	(27.0)

properties, as defined in ASTM Standard E399. The average critical plane strain toughness value for the L-T oriented specimens was 24.6 KSI \sqrt{in} (27.0 MPa \sqrt{m}), well below that for aluminum 7050-T73651 plate at nearly 37 KSI \sqrt{in} (40.7 MPa \sqrt{m}). [2]

4.7 FATIGUE CRACK GROWTH RATE

Fatigue crack growth rate results for both lab air and high humidity (>90 percent R.H.) conditions are presented in Figure 11. Data for both conditions reflect the results of two specimens per condition. Also shown is reference data for aluminums 7050-T73511 extrusion [4] and 7050-T73651 plate [2] tested under similar lab air conditions. Results show a substantial reduction in crack growth resistance for P/M 7090 compared to I/M 7050, which is consistent throughout the range of stress intensities examined. For aluminum 7090, the high humidity environment caused a slight increase in crack growth rate at the higher stress intensities. At the lower stress intensities, the data for both humidity conditions overlap.

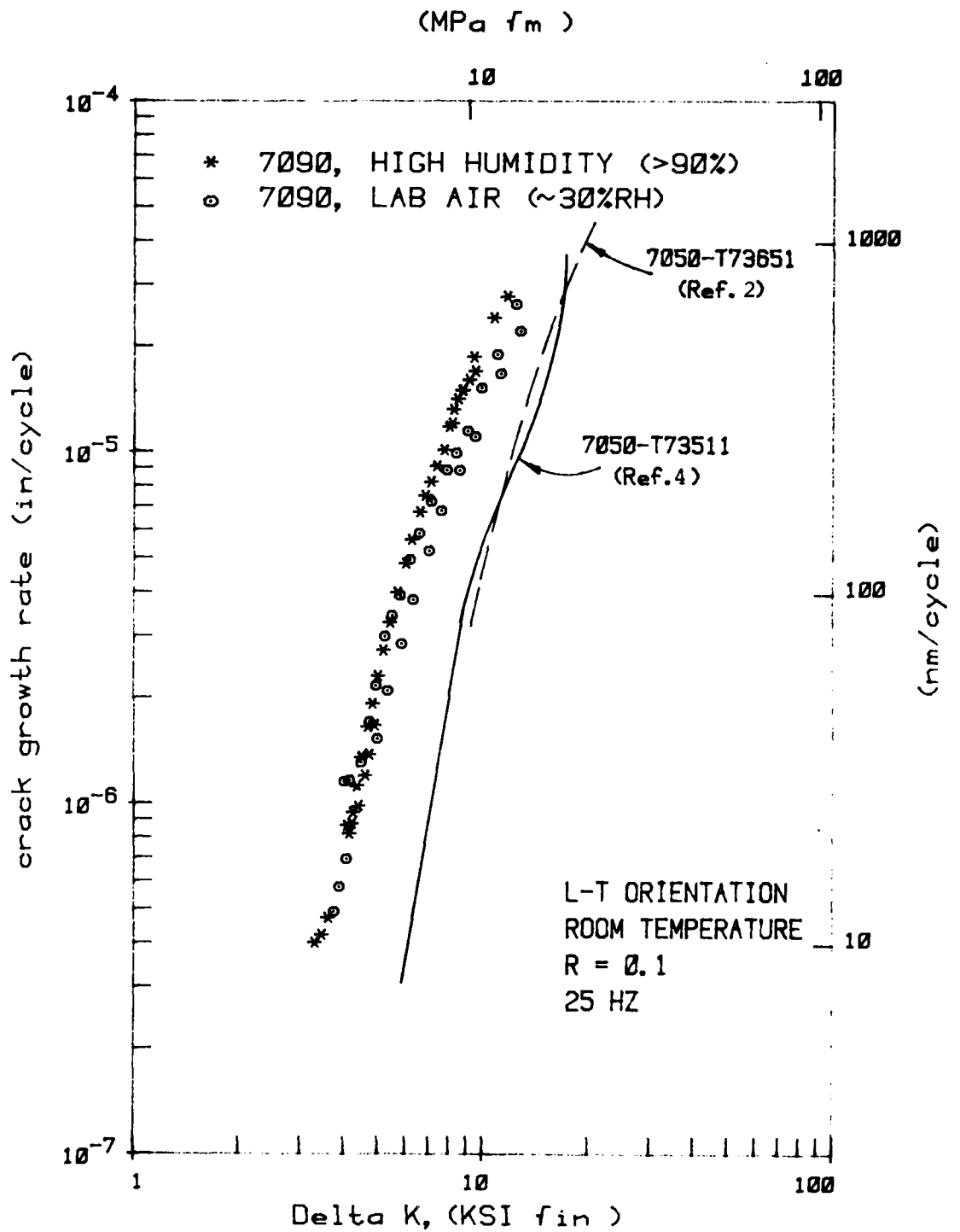

Figure 11. Fatigue Crack Growth Rate Results for P/M Aluminum 7090-T7E71 Plate.

SECTION V CONCLUSIONS

The following conclusions are based on results from a single test plate of P/M aluminum 7090-T7E71. Findings could be altered by a more in-depth testing program involving numerous lots of the test material.

1. The test material is a very high strength aluminum alloy, with tensile properties superior to the majority of 7000-series aluminum alloys.
2. Compression yield strength of the test plate is outstanding; compressive yield strength values exceed the tensile ultimate strengths for both plate directions examined.
3. Shear and bearing properties of 7090-T7E71 plate are clearly superior to those of aluminum 7050 and 7075 plates in their respective corrosion resistant tempers.
4. Constant amplitude fatigue properties at both smooth and notched ($K_t = 3$) conditions are likewise superior to most 7000-series I/M alloys, including 7050-T73651.
5. Fracture toughness properties of 7090-T7E71 plate are low, well below that for 7050 plate. Critical plane-strain toughness of the test material in the L-T plate direction is less than $25 \text{ KSI}\sqrt{\text{in}}$ ($27.5 \text{ MPa}\sqrt{\text{m}}$).
6. Constant amplitude fatigue crack growth rate properties of the test material are inferior to aluminum 7050 throughout the range of stress intensities examined. An increase in relative humidity from 30 to 90 percent caused a slight increase in growth rates only at the higher stress intensity ranges.

REFERENCES

1. Otto, W. L., Jr., "Metallurgical Factors Controlling Structure in High Strength Aluminum P/M Products," AFML-TR-76-60, May 1976.
2. Jones, R. E. and Fudge, K. A., "Engineering Design Data for Aluminum 7050-T73651 Plate," AFML-TR-73-269, November 1973.
3. Ruschau, John J., "Mechanical Property Data on P/M Aluminum X7091-T7E69 Extrusion," AFWAL-TR-82-4161, October 1982.
4. Petrak, G. J., "Effects of Purity Level on the Mechanical Properties of 7000-Series Aluminums," AFWAL-TR-80-4079, October 1980.