

LEVEL III

2

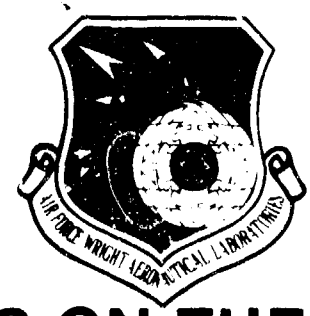

AFWAL-TR-81-3041
VOLUME 2

AD A101658

EFFECT OF VARIANCES AND MANUFACTURING TOLERANCES ON THE DESIGN STRENGTH AND LIFE OF MECHANICALLY FASTENED COMPOSITE JOINTS

VOLUME 2 - TEST DATA, EQUIPMENT AND PROCEDURES

S.P. Garbo, J.M. Ogonowski, and H.E. Reiling, Jr.

McDonnell Aircraft Company
McDonnell Douglas Corporation
P.O. Box 516
St. Louis, Missouri 63166

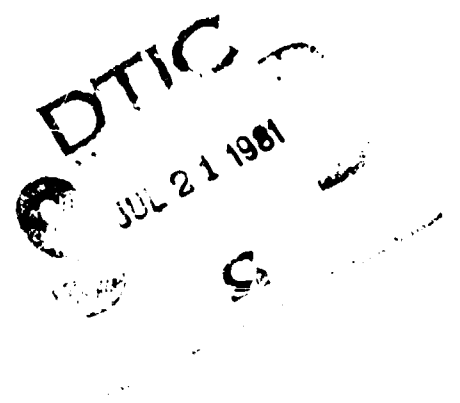

April 1981

Final Report for Period 15 February 1978 - 15 April 1981

Approved for public release; distribution unlimited

FLIGHT DYNAMICS LABORATORY
AIR FORCE WRIGHT AERONAUTICAL LABORATORIES
AIR FORCE SYSTEMS COMMAND
WRIGHT-PATTERSON AIR FORCE BASE, OHIO 45433

81 7 21 010

DWG FILE COPY

NOTICE

When Government drawings, specifications, or other data are used for any purpose other than in connection with a definitely related Government procurement operation, the United States Government thereby incurs no responsibility nor any obligation whatsoever; and the fact that the government may have formulated, furnished, or in any way supplied the said drawing, specifications, or other data, is not to be regarded by implication or otherwise as in any manner licensing the holder or any other person or corporation, or conveying any rights or permission to manufacture, use, or sell any patented invention that may in any way be related thereto.

This report has been reviewed by the Office of Public Affairs, (ASD/PA) and is releasable to the National Technical Information Service (NTIS). At NTIS, it will be available to the general public, including foreign nations.

This technical report has been reviewed and is approved for publication.

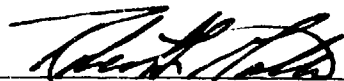

ROBERT L. GALLO, Capt, USAF
Project Engineer

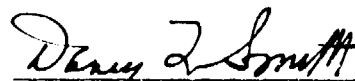

DAVEY L. SMITH, Chief
Structural Integrity Branch
Structures and Dynamics Division

FOR THE COMMANDER

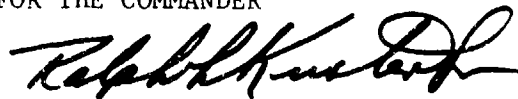

RALPH L. KUSTER, Jr., Col, USAF
Chief, Structures and Dynamics Division

If your address has changed, if you wish to be removed from our mailing list, or if the addressee is no longer employed by your organization, please notify AFWAL/FIBEC, Wright-Patterson AFB, OH 45433 to help us maintain a current mailing list. Copies of this report should not be returned unless return is required by security considerations, contractual obligations, or notice on a specific document.

12 145

SECURITY CLASSIFICATION OF THIS PAGE (When Data Entered)

19 REPORT DOCUMENTATION PAGE		READ INSTRUCTIONS BEFORE COMPLETING FORM	
1. REPORT NUMBER AFWAL/TR-81-3041-VOL-2	2. GOVT ACCESSION NO. AD-A101658	3. RECIPIENT'S CATALOG NUMBER	
4. TITLE (and Subtitle) EFFECT OF VARIANCES AND MANUFACTURING TOLERANCES ON THE DESIGN STRENGTH AND LIFE OF MECHANICALLY FASTENED COMPOSITE JOINTS VOLUME 2. Test Data, Equipment and Procedures.	5. PERIOD COVERED Final Report, 15 Feb 1978 - 15 Apr 1981	6. PERFORMING ORG. REPORT NUMBER	
7. AUTHOR P. Garbo J. M. Ogonowski H. K. Reiling, Jr.	8. CONTRACT OR GRANT NUMBER(s) F33615-77-C-3140	9. PROGRAM ELEMENT PROJECT TASK AREA & WORK UNIT NUMBERS P.E. 62201F W.U. 24010110	
11. CONTROLLING OFFICE NAME AND ADDRESS Flight Dynamics Laboratory (AFWAL/FIBEC) Air Force Wright Aeronautical Lab. AFSC Wright-Patterson AFB, Ohio 45433	12. REPORT DATE Apr 1981	13. NUMBER OF PAGES 135	
14. MONITORING AGENCY NAME & ADDRESS (if different from Controlling Office)	15. SECURITY CLASS (of this report) Unclassified	15A. DECLASSIFICATION DOWNGRADING SCHEDULE	
16. DISTRIBUTION STATEMENT (of this Report) Approved for public release; distribution unlimited.			
17. DISTRIBUTION STATEMENT (of the Abstract entered in Block 20, if different from Report)			
18. SUPPLEMENTARY NOTES			
19. KEY WORDS (Continue on reverse side if necessary and identify by block number) Bolted Joints Methodology Composite Load Distributions Graphite-epoxy Stress Analysis Orthotropic Failure Criteria Stress Concentrations Fatigue Life			
20. ABSTRACT (Continue on reverse side if necessary and identify by block number) The subject of this program was structural evaluation of mechanically fastened composite joints. Program objectives were 'threefold': (1) development and verification by test of improved static strength methodology; (2) experimental evaluation of the effects of manufacturing anomalies on joint static strength; and (3) experimental evaluation of joint fatigue life.			

DD FORM 1 JAN 73 1473

SECURITY CLASSIFICATION OF THIS PAGE (When Data Entered)

403111

SECURITY CLASSIFICATION OF THIS PAGE(When Data Entered)

Program activities to accomplish these objectives were organized under five tasks. Under Task 1 - Literature Survey, a survey was performed to determine the state-of-the-art in design and analysis of bolted composite joints. Experimental evaluations of joint static strength were performed under Tasks 2 and 3. In Task 2 - Evaluation of Joint Design Variables, strength data were obtained through an experimental program to evaluate the effects of twelve joint design variables. Task 3 - Evaluation of Manufacturing and Service Anomalies, effects of seven anomalies on joint strength were evaluated experimentally and compared with Task 2 strength data. Bolted composite joint durability was evaluated under Task 4 - Evaluation of Critical Joint Design Variables On Fatigue Life. Seven critical design variables or manufacturing anomalies were identified based on Task 2 and 3 strength data. Under Task 5 - Final Analyses and Correlation, required data reduction, methodology development and correlation, and necessary documentation were performed.

This report documents all program activities performed under Tasks 2, 3, 4 and 5. Activities performed under Task 1 - Literature Survey, were previously reported in AFFDL-TR-78-179. Static strength methodology and evaluations of joint static and fatigue test data are reported. Analytic studies complement methodology development and illustrate: the need for detailed stress analysis, the utility of the developed "Bolted Joint Stress Field Model" (BJSFM) procedure, and define model limitations. For static strength data, correlations with analytic predictions are included. Data trends in all cases are discussed relative to joint strength and failure mode. For joint fatigue studies, data trends are discussed relative to life, hole elongation, and failure mode behavior.

This final report is organized in the following three volumes:

- Volume 1 - Methodology Development and Data Evaluation
- Volume 2 - Test Data, Equipment and Procedures
- Volume 3 - Bolted Joint Stress Field Model (BJSFM) Computer Program User's Manual

SECURITY CLASSIFICATION OF THIS PAGE(When Data Entered)

FOREWORD

The work reported herein was performed by the McDonnell Aircraft Company (MCAIR) of the McDonnell Douglas Corporation (MDC), St. Louis, Missouri, under Air Force Contract F33615-77-C-3140, for the Flight Dynamics Laboratory, Wright-Patterson Air Force Base, Ohio. This effort was conducted under Project No. 2401 "Structural Mechanics", Task 240101 "Structural Integrity for Military Aerospace Vehicles", Work Unit 24010110 "Effect of Variances and Manufacturing Tolerances on the Design Strength and Life of Mechanically Fastened Composite Joints". The Air Force Project Engineer at contract go-ahead was Mr. Roger J. Aschenbrenner (AFWAL/FIBEC); in December 1979, Capt. Robert L. Gallo (AFWAL/FIBEC) assumed this assignment. The work described was conducted during the period 15 February 1978 through 15 April 1981.

Program Manager was Mr. Ramon A. Garrett, Branch Chief Technology, MCAIR Structural Research Department. Principal Investigator was Mr. Samuel P. Garbo, MCAIR Structural Research Department.

Accession For	
NTIS GRA&I	<input checked="" type="checkbox"/>
DTIC TAB	<input type="checkbox"/>
Unannounced	<input type="checkbox"/>
Justification	
By	
Distribution/	
Availability Codes	
Dist	Avail and/or Special
A	

TABLE OF CONTENTS

<u>Section</u>		<u>Page</u>
I	INTRODUCTION	1
II	RESULTS OF TASK 2 TESTING - JOINT DESIGN VARIABLES	2
	1. TEST MATRIX AND TEST OBJECTIVES	2
	2. SPECIMEN CONFIGURATIONS	2
	3. SPECIMEN QUALITY ASSURANCE	11
	4. PANEL FABRICATION	11
	5. SPECIMEN FABRICATION	13
	6. TEST PROCEDURES	13
	7. TEST EQUIPMENT	14
	8. SPECIAL PROCEDURES	18
	9. TEST DATA	18
III	RESULTS OF TASK 3 TESTING - MANUFACTURING AND SERVICE ANOMALIES	69
	1. TEST MATRIX AND TEST OBJECTIVES	69
	2. SPECIMEN CONFIGURATIONS	69
	3. SPECIMEN QUALITY ASSURANCE	69
	4. PANEL FABRICATION	73
	5. SPECIMEN FABRICATION	74
	6. TEST PROCEDURES	74
	7. TEST EQUIPMENT	75
	8. SPECIAL PROCEDURES	75
	9. TEST DATA	85
IV	RESULTS OF TASK 4 TESTING - CRITICAL JOINT DESIGN VARIABLES ON FATIGUE LIFE	99
	1. TASK 4 - TEST MATRIX AND TEST OBJECTIVE	99
	2. SPECIMEN CONFIGURATION	101
	3. SPECIMEN QUALITY ASSURANCE	101
	4. PANEL FABRICATION	101
	5. SPECIMEN FABRICATION	101
	6. TEST PROCEDURES	104
	7. TEST EQUIPMENT	107
	8. SPECIAL PROCEDURES	107
	9. TEST DATA	109

LIST OF ILLUSTRATIONS

<u>Figure</u>		<u>Page</u>
1	Task 2 - Joint Design Variables Test Matrix	3
2	Baseline Specimen Configuration	5
3	Single-Test Specimens	6
4	Multi-Test Specimens	9
5	Panel Configurations	12
6	Double Shear Test Setup	15
7	Environmental Exposure Schedule	16
8	Load-Interaction Test Setup	17
9	Exploded View of Salt Spray Exposure Test Setup After Exposure	19
10	Single Fastener Test Setups	28
11	Bearing Mode of Failure	34
12	Bearing Mode of Failure (40 Ply)	35
13	Bearing-Shearout Mode of Failure	36
14	Bearing-Shearout Mode of Failure	37
15	Bearing-Shearout Mode of Failure (10° Off Axis Test)	38
16	Shearout-Tension-Cleavage Mode of Failure (22.5° Off Axis Test)	39
17	Bearing-Shearout-Tension-Cleavage Mode of Failure (45° Off Axis Test).	40
18	Shearout-Tension-Cleavage Mode of Failure (67.5° Off Axis Test)	41
19	Shearout-Tension-Cleavage Mode of Failure (80° Off Axis Test)	42
20	Bearing-Net Section Mode of Failure (90° Off Axis Test)	43

LIST OF ILLUSTRATIONS (Continued)

<u>Figure</u>		<u>Page</u>
21	Multiple Fastener Test Setups	57
22	Net Section Mode of Failure	63
23	Bearing-Shearout Mode of Failure	64
24	Bearing (Compression Test) Mode of Failure	65
25	Fastener Pattern Tension Test Specimens After Testing	66
26	Tension-Cleavage Mode of Failure	67
27	Load Interaction Tension Net Section Failures (45° Off Axis Test)	68
28	Task 3 - Evaluation of Manufacturing Anomalies - Test Matrix	70
29	Task 3 Test Specimens	71
30	Panel Configurations	73
31	Average Moisture Content for Task 3 Specimens	75
32	Hole Drilling Anomalies	76
33	Severe Porosity in Test Specimen Indicated by Photomicrographs	78
34	Moderate Porosity in Test Specimen Indicated by Photomicrographs	79
35	Freeze-Thaw Exposure Profile	80
36	Photomicrographic Results of 0.0072 Inch Interference Fit	81
37	Photomicrographic Results of 0.0053 Inch Interference Fit	82
38	Photomicrographic Results of 0.0043 Inch Interference Fit	83
39	Photomicrographic Results of 0.0030 Inch Interference Fit	84
40	Ultrasonic "C"-Scans of Test Specimen Anomalies	86

LIST OF ILLUSTRATIONS (Continued)

<u>Figure</u>		<u>Page</u>
41	Task 3 Test Setups	93
42	Tension-Cleavage Mode of Failure	95
43	Bearing-Shearout Mode of Failure	96
44	Bearing-Shearout Mode of Failure	97
45	Bearing-Shearout Mode of Failure	98
46	Task 4 - Evaluation of Critical Joint Design Parameters on Fatigue Life - Test Matrix	99
47	Fatigue Test Specimens	102
48	Panel Configurations	103
49	Measured Mix-Truncated Spectrum	106
50	Task 4 Environmental Exposure Schedule	107
51	Thermal Spike Cycle	108
52	Task 4 Test Setups	113
53	Static Not Section and Tension-Cleavage Modes of Failure	117
	Static Bearing and Shearout Modes of Failure	118
54	Constant Amplitude (R = 0.1) Tension-Cleavage and Shearout Modes of Failure	125
55	Constant Amplitude (R = 0.1) bearing and Tension-Cleavage Modes of Failure	128
56	Constant Amplitude (R = 0.1) Not Section and Tension-Cleavage Modes of Failure	129
57	Constant Amplitude (R = -1.0) Bearing Modes of Failure	130
58	Spectrum Fatigue Bearing and Bearing-Shearout Modes of Failure	135

LIST OF TABLES

<u>Table</u>		<u>Page</u>
1	Tension Strength Test Data	20
2	Compression Strength Test Data	26
3	Tension Strength Test Data	44
4	Compression Strength Test Data	52
5	Load Interaction Strength Test Data	56
6	Nonstandard Panel Fabrication Procedures	77
7	Tension Strength Test Data	87
8	Compression Strength Test Data	91
9	Distribution of Hours and Exceedances	105
10	Static Tension Strength Test Data	110
11	Constant Amplitude Fatigue Test Data	119
12	Spectrum Fatigue Test Data	131

SECTION I

INTRODUCTION

The objective of the five task program was to develop and verify improved methods for predicting static strength and to experimentally evaluate the durability of bolted composite joints. This volume summarizes the procedures and equipment used to conduct the experimental verification program associated with: Task 2 - Evaluation of Joint Design Variables, Task 3 - Evaluation of Manufacturing and Service Anomalies and Task 4 - Evaluation of Critical Joint Design Variables on Fatigue Life.

Results of all testing are tabulated and representative photographs of specimen failures included. The body of this document is divided into the following sections for each task:

1. Test Matrix and Test Objectives
2. Specimen Configurations
3. Specimen Quality Assurance
4. Panel Fabrication
5. Specimen Fabrication
6. Test Procedures
7. Test Equipment Used
8. Special Procedures
9. Test Data

SECTION II

RESULTS OF TASK 2 TESTING - JOINT DESIGN VARIABLES

1. TEST MATRIX AND TEST OBJECTIVES - The objective of Task 2 was to obtain strength data for application-oriented bolted composite joints through an experimental test program. The experimental program to evaluate the effect of twelve design variables on laminate static strength is summarized in Figure 1.

This test matrix defines numbers and types of tests, design variables studied and number of specimens tested. The test matrix was textured to eliminate unnecessary combinations of load and environmental conditions. Tests were performed at three environmental conditions for selected joint design variables; room temperature dry (RTD), room temperature wet (RTW) and elevated temperature wet (ETW). Elevated temperature testing at 250°F and specimen moisture content of approximately .86 percent by weight were selected as representative of structural environments for near term multi-mission high performance fighter aircraft. A replication of four tests were performed for each design variable for a total of 428 tests in Task 2.

All joints tested in Task 2 were a variation of the base-line configuration presented in Figure 2. The two-bolt-in-tandem configuration complements existing pure bearing load-transfer data bases and is representative of current design practices. Load transfer in two-bolt specimens is pure bearing in the first hole and by-pass plus bearing in the second hole, permitting a dual appraisal of strength analysis capabilities.

2. SPECIMEN CONFIGURATIONS - Four general test specimen configurations were used in Task 2; (a) a single bolt pure bearing, (b) a two-bolt-in-tandem (load sharing), (c) a four bolt fastener pattern specimen, and (d) a two bolt load interaction configuration, all of which are shown in Figure 3. Specific geometry variations required for each design variable are detailed in tables associated with the illustrated configurations.

Four tests were obtained from each room temperature dry specimen with both a single bolt and double bolt configuration (Figure 4). These specimens were tested, the failed portion of the specimen machined off and a new hole(s) drilled for subsequent testing. Length of the removed portion depended upon extent of damage sustained during the preceding test. Ultrasonic C-scans indicate that laminate damage is confined to the vicinity in front of and immediately around the bolt hole while the gross laminate is unaffected by a previous static test due to the low laminate strain levels at failure. This procedure minimized the amount of material used, minimized material variation between tests and utilized a common strain gage. Every specimen was strain gaged as shown in the individual figures.

JOINT DESIGN VARIABLE	TEST SPECIMEN	CONFIGURATION		RTD		RTW		ETW		TOTAL TESTS
		LAYUP	VARIATION	TEN.	COM	TEN.	COM	TEN.	COM	
1 FASTENER TORQUE	TYPE I	1,2,3	0 IN.-LB	✓,+,+				✓		34
		1,2,3	25	✓,+,+				✓		
		1,2,3	50	✓,✓,✓						
		1,2,3	75	✓,✓,✓						
2 STACKING SEQUENCE	TYPE II	1,2,3	0 IN.-LB	✓,+,+				✓		34
		1,2,3	25	✓,+,+				✓		
		1,2,3	50	✓,✓,✓						
		1,2,3	75	✓,✓,✓						
3 SINGLE SHEAR	TYPE I	1	LAYUP NO. 6	✓	✓			✓		48
		1	LAYUP NO. 7	✓	✓			✓		
		1	LAYUP NO. 8	✓	✓			✓		
		1	LAYUP NO. 9	✓	✓			✓		
4 THICKNESS	TYPE I	1	△ e/d = 2.0	✓	✓			✓		24
		1	w/d = 4.0	✓	✓			✓		
		1	d = 0.375	✓	✓			✓		
		1		✓	✓			✓		
5 COUNTERSUNK FASTENERS	TYPE I	1	t ₁ = 0.416	✓	✓			✓		32
		1	t ₂ = 0.624	✓	✓			✓		
6 LOAD ORIENTATION (OFF-AXIS LOADS BEARING AND BYPASS ALIGN)	TYPE I	1	(h/t) ₁ = 0.77	✓	✓			✓		20
		1	(h/t) ₂ = 0.38	✓	✓			✓		
		1	(h/t) ₃ = 0.26	✓	✓			✓		
		1	(h/t) ₁ & T _i (h/t) ₁ & A _i	✓	✓			✓		
SUBTOTAL		1	θ ₁ = 10°	✓	✓			✓		48
		1	θ ₂ = 22.5°	✓	✓			✓		
		1	θ ₃ = 45°	✓	✓			✓		
		1	θ ₄ = 90°	✓	✓			✓		
SUBTOTAL										264

△ Baseline configuration with protruding head fastener

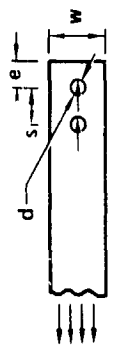
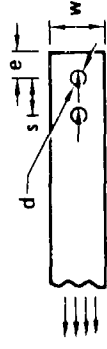

Figure 1. Task 2 - Joint Design Variables Test Matrix

OP12-0115-172

JOINT DESIGN VARIABLE	TEST SPECIMEN	CONFIGURATION ¹		RTD		RTW		ETW		TOTAL TESTS
		LAYUP	VARIATION	TEN	COM	TEN	COM	TEN	CCM	
7 HOLE SIZE		1	$d_1 = 0.1875$	>>>						12
		1	$d_2 = 0.375$	>>>						
		1	$d_3 = 0.500$	>>>						
8 EDGE DISTANCE		1	$(e/d)_1 = 1.5$	>>>>>						40
		1	$(e/d)_2 = 2.0$	>>>>>						
		1	$(e/d)_3 = 4.0$	>>>>>						
9 WIDTH		1	$s_1 = 2d$	>>>						24
		1	$s_2 = 3d$	>>>						
		1	$(w/d)_1 = 4.0$ $(w/d)_2 = 5.0$ $(w/d)_3 = 8.0$	>>>						
10 LAYUP		1	(BASELINE)	>>>		>		>>>		56
		2		>>>				>>>		
		3		>>>				>>>		
11 FASTENER PATTERNS		1	Ti	>>>>>		● ●		>>>>>		60
		3	AI	>>>>>		● ●		>>>>>		
		1		>>>>>				>>>>>		
12 LOAD INTERACTION (BYPASS AND BEARING NONALIGNED)		1	$\theta = 0^\circ$	>>>>>		>		>>>>>		22
		3	$\theta = 0^\circ$	>>>>>				>>>>>		
		1	$\theta_1 = 10^\circ$	>>>>>				>>>>>		
		1	$\theta_2 = 22.5^\circ$	>>>>>				>>>>>		
		1	$\theta_3 = 45^\circ$	>>>>>				>>>>>		
TOTAL										478



● 4 tests, T300/5208 Graphite/Epoxy
 ▲ 4 tests after exposure to salt water environment, AS/3501-6

GP13-0115-122

Figure 1. (Continued) Task 2 - Joint Design Variables Test Matrix

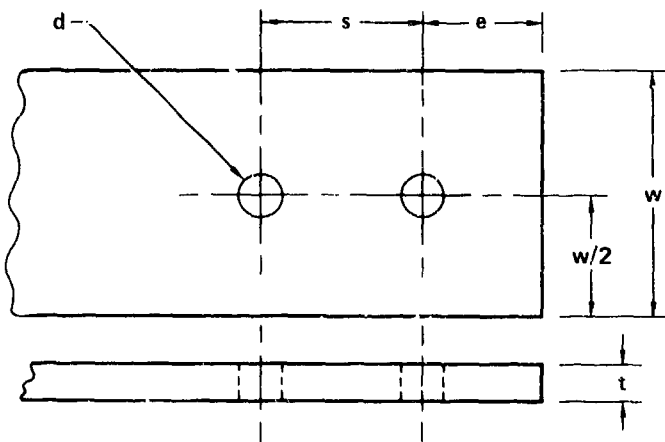

LAMINATE:	LAYUP NO. 1 50/40/10
STACKING SEQUENCE:	[+45°, 0°, -45°, 0°, 90°, 0°, +45°, 0°, -45°, 0°] _s
THICKNESS (t):	0.208 IN. NOMINAL (20 PLIES)
HOLE SIZE (d):	0.2495 IN. NOMINAL
HOLE CLEARANCE:	MCAIR CLASS I ⁺ FIT 0.2495 (+0.0022/-0.0000) IN.
FASTENER TYPE:	ST3M 453-4 (0.2495 + 0.0000/-0.0005 IN. DIAMETER)
TORQUE VALUE:	50 IN.-LB (1/4 IN. FASTENER)
WIDTH (w):	1.50 IN. (w/2d = 3.0)
EDGE DISTANCE (e):	0.75 IN. (e/d = 3.0)
HOLE SPACING(s):	1.00 IN.
LOAD CONFIGURATION:	DOUBLE-SHEAR

Figure 2. Baseline Specimen Configuration

QP13-0115-132

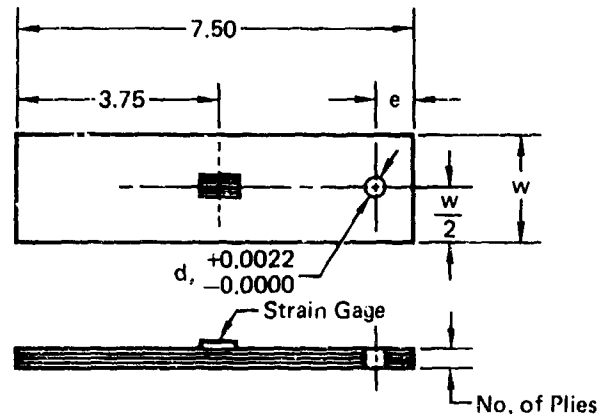

Specimen Configuration	No. of Plies	w (in.)	e (in.)	d, (in.)
3A	20	1.500	0.750	0.2495
3B			0.500	
3C	40	2.250	1.125	0.3745
3D	60			
3E				0.5620

a) Single Fastener Specimens

Note: All dimensions are in inches.

QP13-0115-133

Figure 3. Single-Test Specimens

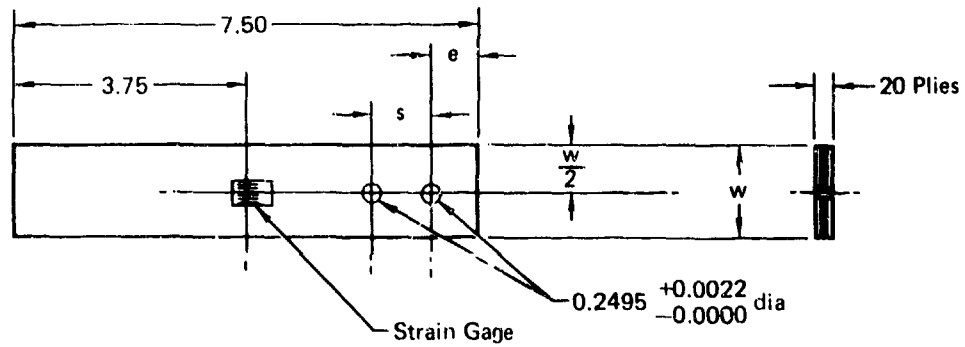

Specimen Configuration	w (in.)	e (in.)	s (in.)
3F	1.500	0.750	1.000
3G		0.500	
3H		1.000	
3I		0.375	
3J	2.000	0.750	0.750
3K			0.500
3L	1.250	0.750	1.000
3N	1.000		

b) Multiple Fastener Specimens

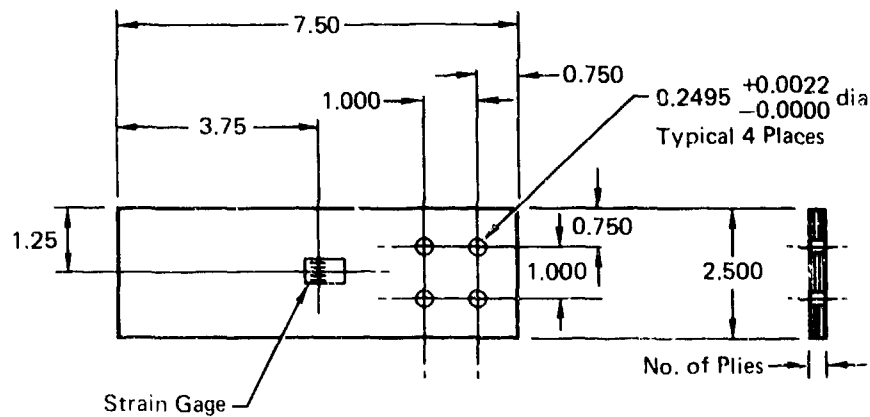

Specimen Configuration 3P (20 Plies)
 Specimen Configuration 3Q (40 Plies)

c) Fastener Pattern Specimen

GP13-0115-134

Figure 3. (Continued) Single-Test Specimens

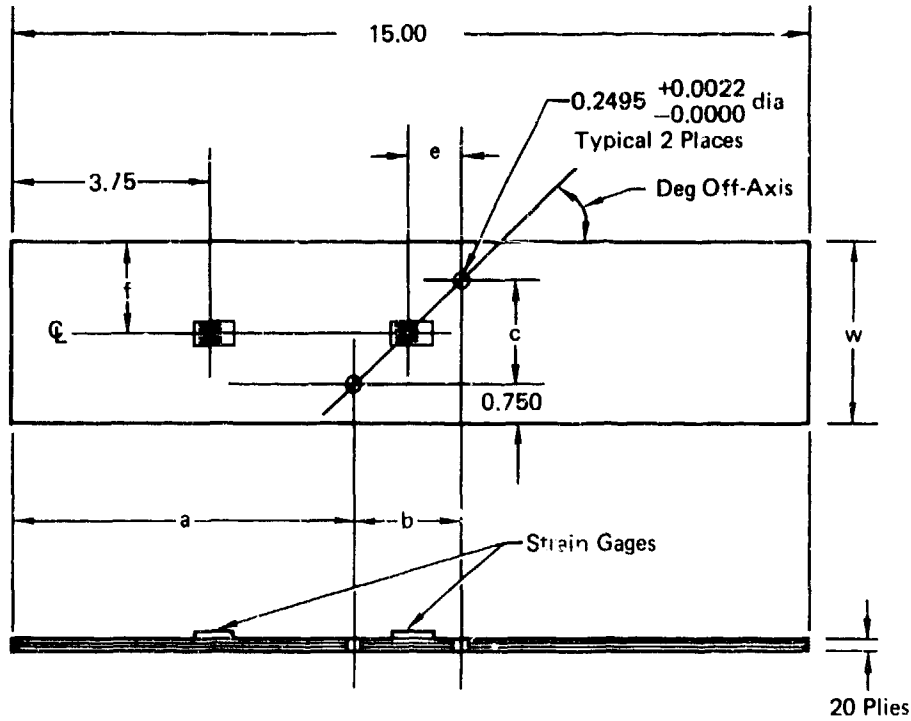

Specimen Configuration	Dimensions (in.)						Deg Off-Axis
	a	b	c	e	f	w	
3R	6.082	2.836	0.500	1.42	1.00	2.000	10
3S	6.293	2.414	1.000	1.20	1.25	2.500	22.5
3T	6.500	2.000	2.000	1.00	1.75	3.500	45

d) Load Interaction Specimens

GP13-0115-228

Figure 3. (Continued) Single-Test Specimens

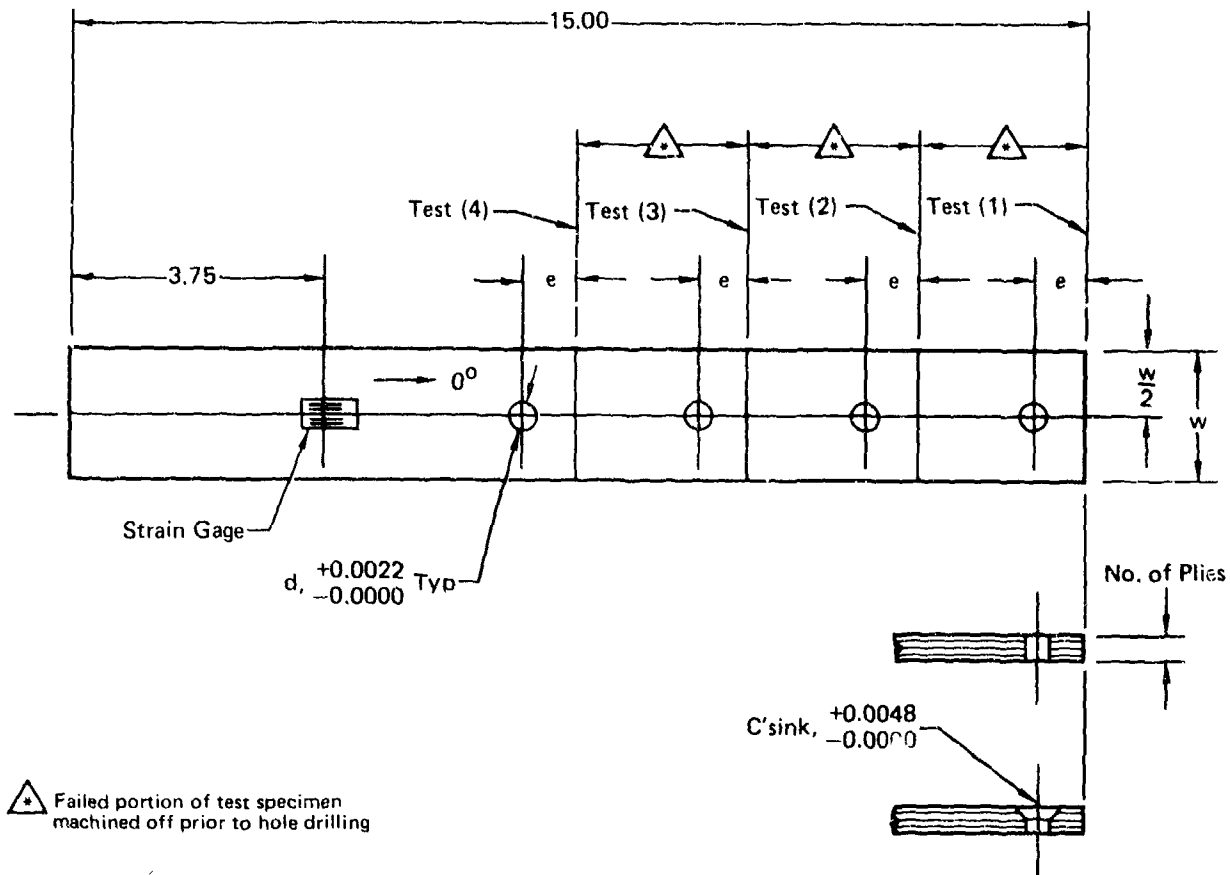

Specimen Configuration	No. of Plies	w (in.)	e (in.)	d (in.)	C'sink (in.)
4A	20	1.500	0.750	0.2495	NA
4B			0.500		
4C		1.000	0.750		
4D					
4E	40	2.250	1.125	0.3745	100° x 0.7556
4F	60				
4G	20				
4H	40				
4I	60				

a) Single Fastener Specimens

QP13-0115-135

Figure 4. Multi-Test Specimens

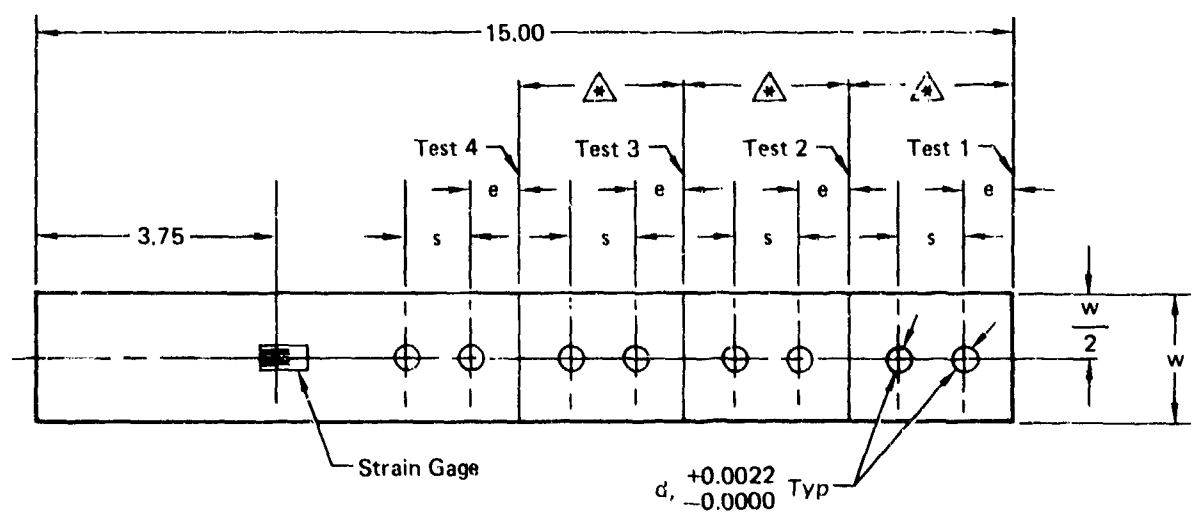

Note: All dimensions are in inches.

▲ Failed portion of test specimen machined off prior to hole drilling.

20 Plies

Specimen Configuration	w (in.)	e (in.)	s (in.)	d, (in.)
4J	1.500	0.750	1.000	0.2495
4K	3.000	1.500	2.000	0.4995
4L	2.250	1.125	1.500	0.3745
4M	1.125	0.568	0.750	0.1870
4N	1.500	0.500	1.000	0.2495
4P		1.000		
4Q		0.375		
4R		0.750	0.750	
4S			0.500	
4T	1.000	0.750	1.000	
4U	1.250			
4V	2.000			

b) Multifastencr Specimens

QP13-0115-227

Figure 4. (Continued) Multitest Specimens

For specimens requiring moisture preconditioning, only single tests were performed with each specimen to minimize out-time prior to specimen testing. In Task 2, 47 multi-test, 204 single test, 60 fastener pattern and 16 load interaction specimens were required to complete the experimental evaluation of joint design variables.

3. SPECIMEN QUALITY ASSURANCE - Hercules AS/3501-6 graphite-epoxy (.0104 inch per ply) was used for fabrication of 311 test specimens. Sixteen specimens were fabricated with Narmco T300/5208 graphite-epoxy (.0054 inch per ply). Prior to testing, a three phase procedure to assure quality of test specimens was performed.

First, material prepreg was mechanically and physically tested to conform with McDonnell material specifications for prepreg resin content, resin flow, volatiles, resin tack, fiber areal weight, and mechanical properties. A vendor certification was required with each shipment of prepreg, to document that it had been tested and found acceptable to the same requirement. Upon receipt of shipment at MCAIR, a receiving inspection was performed to repeat certain mechanical and physical tests to assure that prepreg material was acceptable for usage in panel fabrication.

Process control panels, 3 in. x 4 in. x 8 plies (.08 inch), accompanying each autoclave cure cycle constituted the second phase of quality assurances. Interlaminar shear specimens machined and tested from these panels verified acceptability of each cure cycle run. After fabrication, each panel was inspected using ultrasonic reflection plate techniques per MCAIR process specifications.

The third phase of specimen quality assurance required that machining and drilling of each specimen be in conformance with MCAIR standards. Only specimens which were acceptable in all three phases of quality assurance were used in this test program.

4. PANEL FABRICATION - Nineteen graphite-epoxy panels were fabricated for Task 2. Panel dimensions, corresponding ply orientations, and stacking sequences are listed in Figure 5. Three layup variations were fabricated from the 0°, +45°, 90° family of ply orientations; a baseline 50/40/10 laminate (stacking sequence no. 1) a 30/60/10 laminate (no. 2) and a 70/20/10 laminate (no. 3). All other stacking sequence numbers in Figure 5 refer to variations of the baseline 50/40/10 layup in thickness or stacking sequence.

All panels were fabricated per MCAIR process specifications. Interlaminar shear specimens fabricated from accompanying process control panels were tested to validate each cure cycle run. All panels were accepted for testing in Task 2. The nondestructive evaluation of the nineteen panels by ultrasonic reflection plate techniques indicated no anomalies.

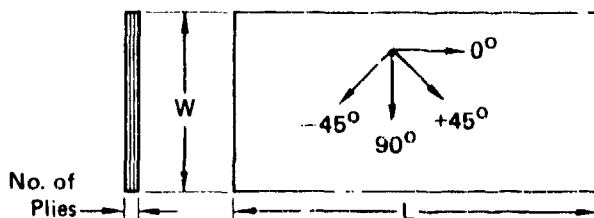

Panel Number	Dimensions (in.)		No. of Plies	Stacking Sequence (See Note.)	Graphite/Epoxy Prepreg Material Used	
	L	W			Lot No.	Spool No.
1	40	24	20	△1	953	3
2	32	12		△2	984	1
3				△3		
4				△4		
5				△5		
6	48	18	40	△6	953	3
7		24	60	△7		3 (Plies 1 → 18) 4 (Plies 19 → 60)
8			△1	4		
9	25	12	20	△8	984	2
10	48	24		△1		
11	40	12				
12	33	24				
13	35					
14	40	12	20	△9	984	2
15		24		△10		3
16				△1		1
17	35	12	40	△11	1,297 △13	11 △13
18				△12		
19	48	24	20	△1	984	3 (Plies 1 → 12) 1 (Plies 13 → 20)

Notes:

- △1 [+45°, 0°, -45°, 0°, 90°, 0°, +45°, 0°, -45°, 0°]S
- △2 [+45°, -45°, 0°₂, +45°, 90°, -45°, 0°₃]S
- △3 [(+45°, -45°)₂, 90°, 0°₅]S
- △4 [+45°, -45°, 0°₂, 90°, 0°, +45°, -45°, 0°₂]S
- △5 [+45°, -45°, 0°₅, +45°, -45°, 90°]S
- △6 [+45°, 0°, -45°, 0°, 90°, 0°, +45°, 0°, -45°, 0°]2S
- △7 [+45°, 0°, -45°, 0°, 90°, 0°, +45°, 0°, -45°, 0°]3S
- △8 [+45°, 90°, -45°, 90°, 0°, 90°, +45°, 90°, -45°, 90°]S
- △9 [+45°, 0°, -45°, 0°₃, 90°, 0°₃]S
- △10 [+45°, 0°, -45°, 0°, +45°, 90°, -45°, 0°, +45°, -45°]S
- △11 [+45°₂, 0°₂, -45°₂, 0°₂, 90°₂, 0°₂, +45°₂, 0°₂, -45°₂, 0°₂]S
- △12 [+45°₂, 0°₂, -45°₂, 0°₂, +45°₂, 90°₂, -45°₂, 0°₂, +45°₂, -45°₂]S
- △13 NARMCO T300/5208 (5 mil per ply thickness) Graphite/Epoxy prepreg material was used in the fabrication of panel numbers 17 and 18. All other panels were fabricated using Hercules AS/3501-6 (10 mil per ply) Graphite/Epoxy prepreg material.

GP13-0115-136

Figure 5. Panel Configurations

5. SPECIMEN FABRICATION - Individual specimens were machined from the panels per MCAIR composite machining processes. Each specimen was uniquely numbered to identify panel number, individual specimen number and test variable assignment according to the following code:

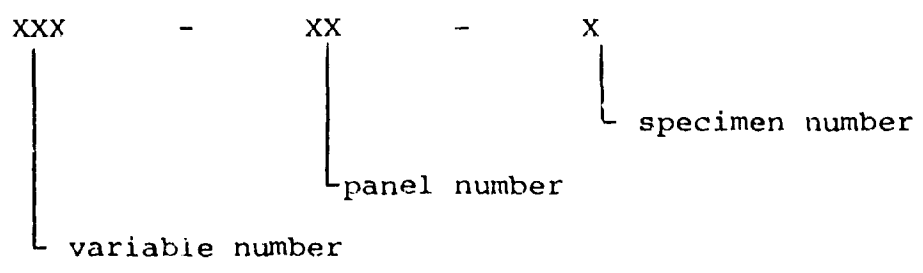

This coding facilitates tracing a specimen back to its panel and location within the panel if necessary. Generally, specimens tested for each design variable were selected from the total body of specimens by a random sampling procedure to preclude test data bias due to panel-to-panel variation. In some test conditions, this involved random selection of specimens from only one fabricated panel, or if there were only a few specimens of unique geometry, no randomization procedure could be used. In other test conditions, however, where sufficient number of specimens existed, selection of specimens from more than one panel was possible. Standard randomization selection processes were used; specimens were numbered and conventional procedures were used to generate random numbers for test condition assignments.

A total of 327 specimens were fabricated for Task 2. Reserve space was allocated in all panels to permit duplication of specimens from the same data base as necessary. Thickness, width and hole diameter were measured for each specimen.

6. TEST PROCEDURES - All specimens were tested to static failure under tensile or compressive loadings as indicated in the Task 2 test matrix (Figure 1). Data documented for all test specimens included:

- o Thickness, width and hole size measurements
- o Failure load and failure strains
- o Load vs. strain plots to failure
- o Load vs. deflection plots to failure
- o Weight gain of humidity exposure specimens
- o Representative photographs

A double shear load block with 1/4 inch diameter bolts torqued to 50 in-lb was the loading fixture used for most tests. Joint load-deflection data was obtained from an externally mounted compliance gage. Deflections were measured relative to

points on the specimen and on the load block outside of the load transfer area. A typical double shear test setup and compliance gage configuration is shown in Figure 6.

Specimens requiring moisture preconditioning were stored in environmental control chambers and their moisture content monitored selectively by measuring weekly weight changes. A multi-phase moisture preconditioning cycle, shown in Figure 7, was used for baseline thickness specimens to minimize preconditioning time required. Specimens were exposed initially to 95 percent relative humidity at 180°F until an average moisture content of approximately 1.0 percent was achieved. Specimens were then exposed to a relative humidity of 55 percent to achieve an equilibrium moisture content (i.e. constant through the thickness) of approximately .86 percent by weight. This moisture content is that which would be achieved in laminate thicknesses typical of fighter aircraft wing skins exposed to a year round average relative humidity of 81 percent at 80°F for ten years.

A one-step preconditioning at 95% relative humidity and 180°F was used for all 40 and 60 ply specimens to achieve desired average moisture levels in less than one year. However, through-the-thickness moisture levels were not expected to be uniform for these specimens.

All specimens tested at 250°F were stabilized for 10 minutes at temperature before testing. All humidity-exposed specimens were weighed immediately before and after environmental exposures. Moisture data for each specimen is presented in Section II.9, Tables 1 through 3.

7. TEST EQUIPMENT - Two test machines were used for tests in Task 2; a Tatnall Testing Machine with a maximum tensile or compressive load capability of 75,000 pounds and a Materials Testing System (MTS) machine with a maximum tensile or compressive load capability of 100,000 pounds. Both machines were equipped with MTS hydraulic grips and variable load rate capability in terms of head travel per minute or applied load per minute. Accuracy of both machines is ± 1 percent of load range. Calibrations were performed quarterly per ASTM standards.

Load blocks were fabricated for each specimen configuration in Task 2. Torque-up was applied in the double shear face configuration by using "floating" bushings in the load block through which a bolt is installed and torqued. The effect of a countersunk fastener was achieved through use of conical shaped bushing ends. Load clevises were steel and designed to a minimum load clevis-to-laminate stiffness ratio of ten to prevent significant variations in bolt-load distributions if material mechanical properties changed. Titanium and aluminum were used as the load block material for those tests requiring different load sharing capabilities (see test matrix, Figure 1).

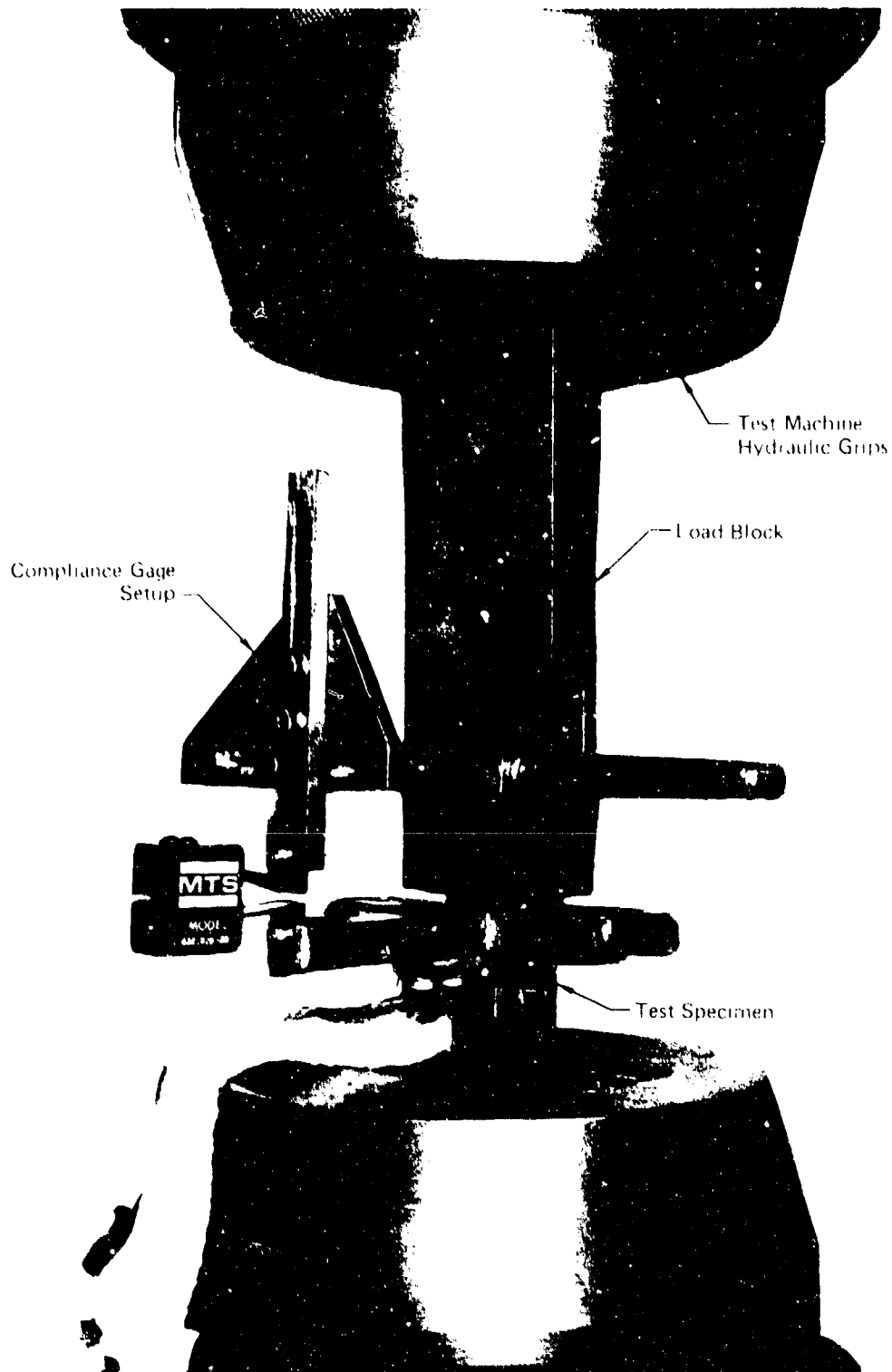

QP13-0115-137

Figure 6. Double-Shear Test Setup

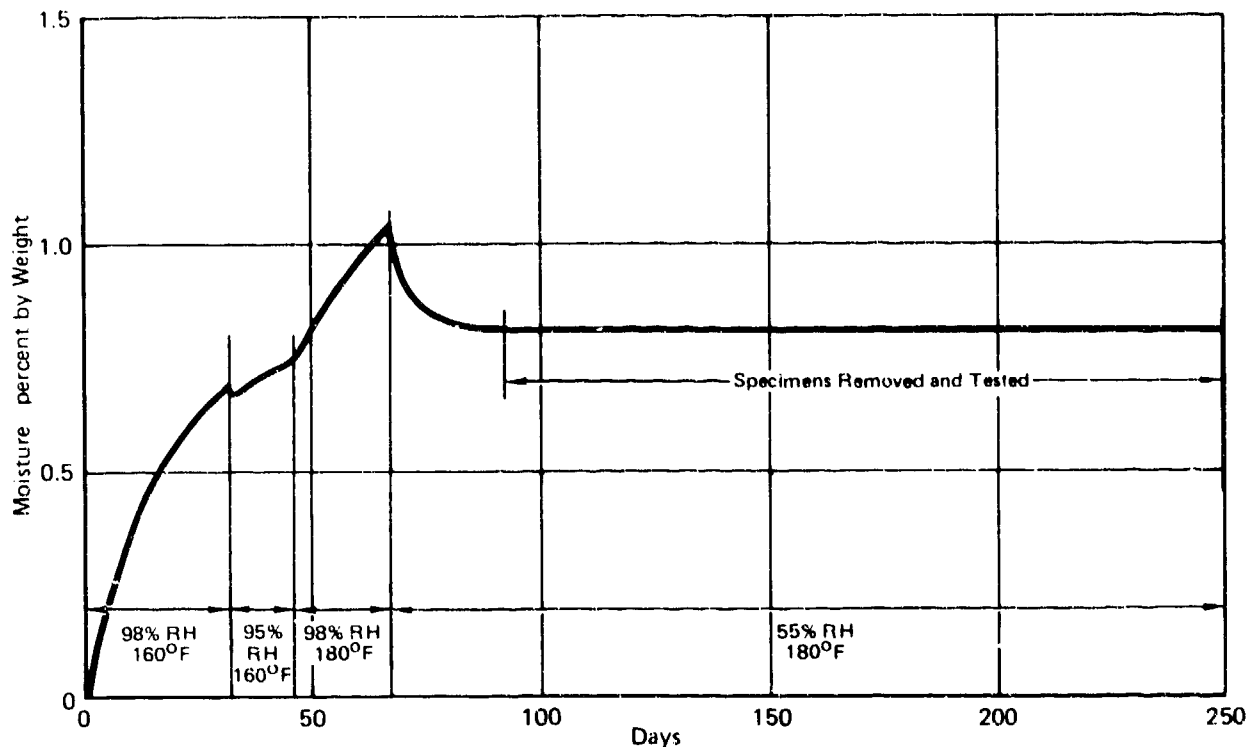

GP13-0115-130

Figure 7. Environmental Exposure Schedule

Load interaction specimens were tested with a specially designed loading fixture. This test fixture (Figure 8) consisted of identical, hydraulically actuated, scissor mechanisms on each side of the test specimen. Self-equilibrating bearing loads were introduced on the test specimen in a double shear configuration. By-pass loads were applied independently through conventional hydraulic grips at the ends of the specimen. Bearing loads were held constant as the by-pass load was increased. This load interaction fixture can be mounted at any angular orientation on the test specimen (Figure 8).

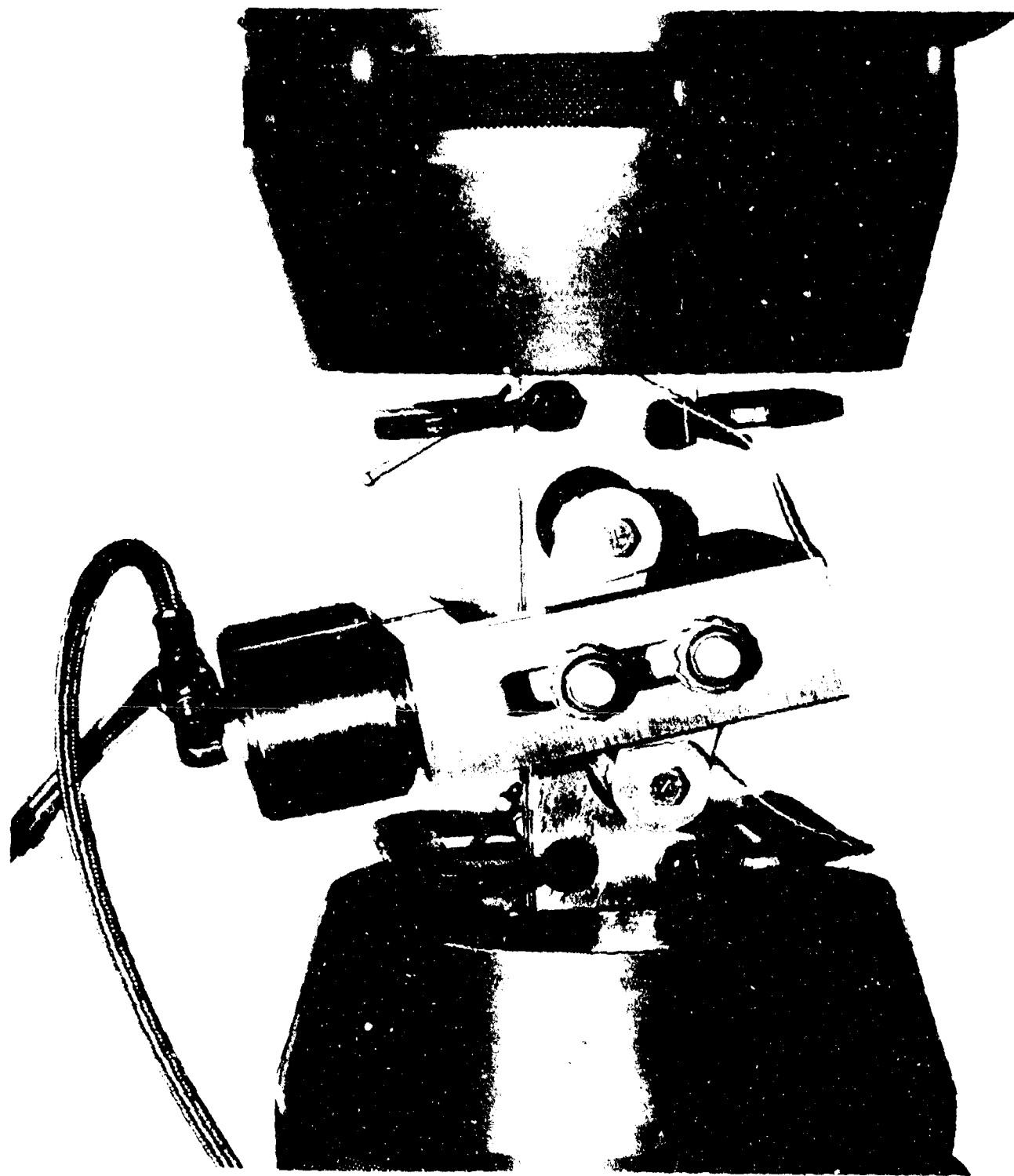

Figure 8. Load-Interaction Test Setup

GP13-0115-130

Additional equipment used in this task were:

- o Moisture conditioning: Blue M Environmental Chambers
- o Weight measurements: Mettler Balance

8. SPECIAL PROCEDURES - Four fastener pattern specimens were subjected to a salt spray environment prior to static testing. After 96 days of humidity exposure following the schedule in Figure 7, the specimens were exposed for 34 days to a salt spray environment. This environment consisted of a 5% NaCl salt spray at 95°F. An Albert Singleton Corp. salt spray cabinet was utilized. The specimens were mechanically fastened to an aluminum plate prior to salt spray exposure to simulate the test configuration. An exploded view of the test set-up after salt spray exposure is shown in Figure 9.

9. TEST DATA - This section contains all specimen geometric data, final moisture content data, failure loads, failure strains and failure mode information for each specimen tested in Task 2. Test results are divided in two parts; single fastener joints and multiple fastener joints.

a. Single Fastener Tests - Tension and compression strength test data for the single fastener joints are presented in Tables 1 and 2 respectively. Specimen and test setups are shown in Figure 10. Representative photographs of specimen failures are shown in Figures 11 through 20.

b. Multiple Fastener Tests - Test data for multiple fastener joints and the load interaction specimens are presented in Tables 3, 4 and 5. Individual specimen and test set-ups for these tests are included in Figure 21. Photographs of representative failed multiple fastener specimens are shown in Figures 22 through 27.

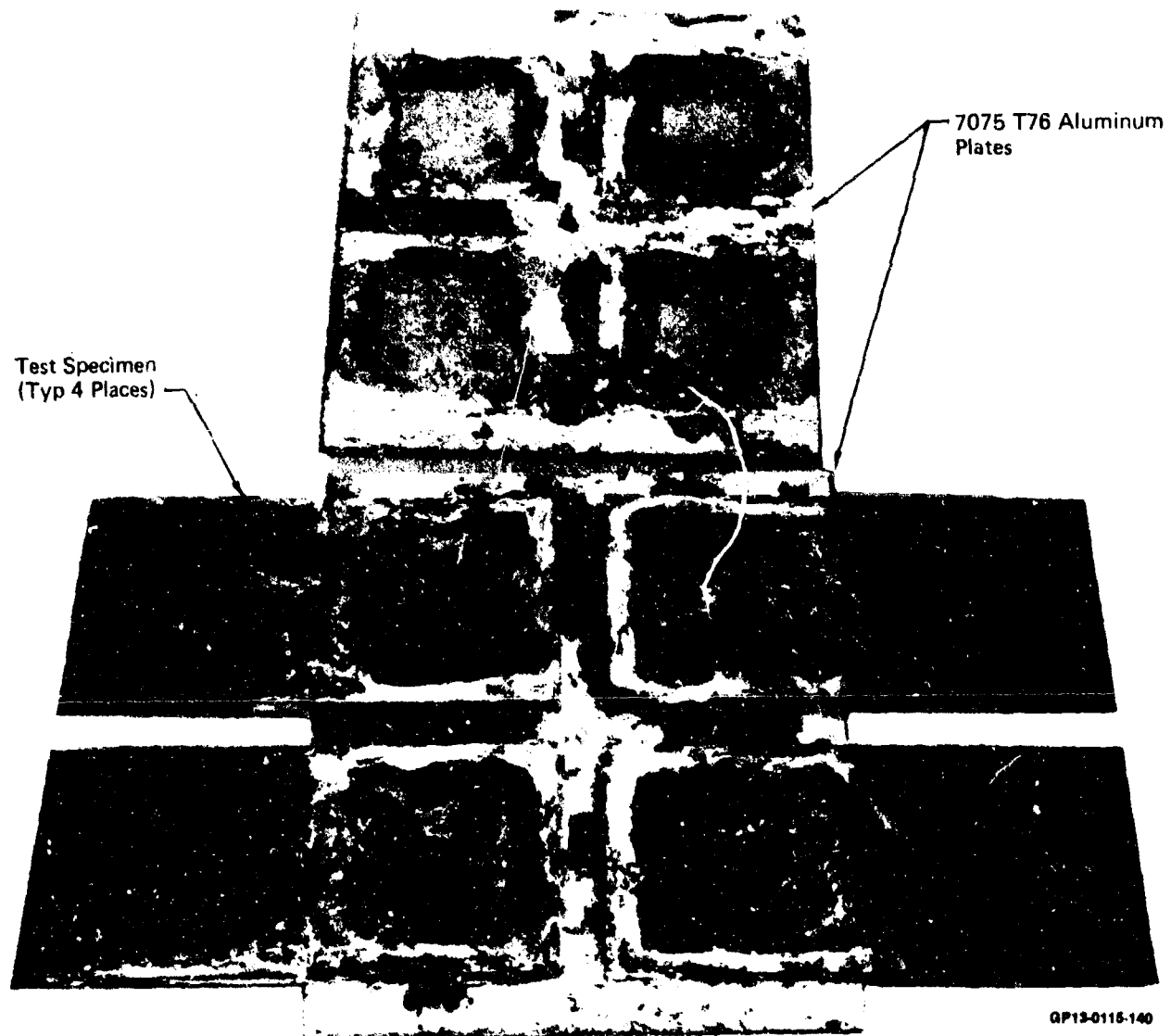



Figure 9. Exploded View of Salt Spray Exposure Test Setup After Exposure

TABLE 1. TENSION STRENGTH TEST DATA

Specimen Number	Specimen and Test Setup Configurations (See Figures)	Percent 0°/45°/90° Plies	Test Variable	Moisture Content (% by Wt)	Test Temp	Fastener Torque (in.-lb)	Thickness (in.)	Width (in.)	Hole Dia (in.)	Failing Load (lb)		Strain at Failure (μin./in.)		Mode of Failure 
										Individual	Average	Individual	Average	
1-1-12(1)	4A, 10A	50/40/10	Fastener Torque	NA	RT	0	0.2116	1.510	0.2508	6,880	7,303	1,950	2,071	④ ①
7,330										7,620	2,060	2,135		
7,620			7,380							2,135	2,140			
7,380			6,240							1,625	1,766			
1-1-12(R)(1)	4A, 10A	50/40/10	Fastener Torque, Gap Between Bushings and Surface of Specimens	NA	RT	0	0.2296	1.481	0.2496	6,420	6,480	1,715	1,766	④ ①
6,420										6,420	1,810	1,915		
6,420			6,840							1,915	2,160			
6,840			7,160							2,160	2,050			
1-10-20(1)	3A, 10A	50/40/10	Fastener Torque	0.82	250°F	25	0.1974	1.505	0.2502	6,900	6,995	2,050	2,106	④ ①
6,900										7,010	2,110	2,105		
7,010										6,910	2,105	1,190		
6,910										3,980	1,190	1,335		
1-10-20(2)	3A, 10A	50/40/10	Fastener Torque	0.78	250°F	25	0.2072	1.506	0.2504	4,080	4,515	1,260	1,335	④ ①
4,080										4,720	1,370	1,520		
4,720										5,280	1,520	1,900		
5,280										6,310	1,900	2,063		
1-10-20(3)	3A, 10A	50/40/10	Fastener Torque	0.80	250°F	25	0.2072	1.506	0.2504	6,840	6,545	2,030	2,063	④ ①
6,840										6,500	2,075	2,143		
6,500										6,730	2,245	760		
6,730										2,460	760	845		
1-10-20(4)	3A, 10A	50/40/10	Fastener Torque	0.86	250°F	25	0.2134	1.507	0.2505	4,100	3,488	845	1,063	④ ①
4,100										4,540	1,263	1,385		
4,540										4,720	1,385	1,325		
4,720										4,200	1,165	1,290		
2-2-1(1)	4A, 10A	50/40/10 Special Panel Number 2	Stacking Sequence	0.75	RT	50	0.1896	1.512	0.2508	4,200	4,370	1,165	1,290	④ ①
4,200										4,200	1,260	1,040		
4,200										4,360	1,410	1,030		
4,360										3,500	1,030	1,086		
2-2-1(2)	4A, 10A	50/40/10 Special Panel Number 2	Stacking Sequence	0.77	RT	50	0.1896	1.512	0.2496	4,200	4,370	1,165	1,290	④ ①
4,200										4,200	1,260	1,040		
4,200										4,360	1,410	1,030		
4,360										3,500	1,030	1,086		
2-2-1(3)	4A, 10A	50/40/10 Special Panel Number 2	Stacking Sequence	0.81	250°F	50	0.1934	1.503	0.2493	3,400	3,448	1,030	1,086	④ ①
3,400										3,230	1,165	1,160		
3,230										3,660	1,160	1,160		
3,660										3,660	1,160	1,160		
2-2-1(4)	4A, 10A	50/40/10 Special Panel Number 2	Stacking Sequence	0.82	250°F	50	0.1929	1.503	0.2506	4,720	4,370	1,325	1,290	④ ①
4,720										4,200	1,165	1,290		
4,200										4,200	1,260	1,040		
4,200										4,360	1,410	1,030		
2-2-3	3A, 10A	50/40/10 Special Panel Number 3	Stacking Sequence	0.75	RT	50	0.1896	1.512	0.2508	4,200	4,370	1,165	1,290	④ ①
4,200										4,200	1,260	1,040		
4,200										4,360	1,410	1,030		
4,360										3,500	1,030	1,086		
2-2-9	3A, 10A	50/40/10 Special Panel Number 3	Stacking Sequence	0.77	RT	50	0.1896	1.512	0.2496	4,200	4,370	1,165	1,290	④ ①
4,200										4,200	1,260	1,040		
4,200										4,360	1,410	1,030		
4,360										3,500	1,030	1,086		
2-2-8	3A, 10A	50/40/10 Special Panel Number 3	Stacking Sequence	0.81	250°F	50	0.1934	1.503	0.2493	3,400	3,448	1,030	1,086	④ ①
3,400										3,230	1,165	1,160		
3,230										3,660	1,160	1,160		
3,660										3,660	1,160	1,160		
2-2-6	3A, 10A	50/40/10 Special Panel Number 3	Stacking Sequence	0.78	250°F	50	0.1929	1.503	0.2506	4,720	4,370	1,325	1,290	④ ①
4,720										4,200	1,165	1,290		
4,200										4,200	1,260	1,040		
4,200										4,360	1,410	1,030		

GP13-0115-141

TABLE 1. (Continued) TENSION STRENGTH TEST DATA

Specimen Number	Specimen and Test Setup Configurations (See Figures)	Percent 0°/45°/90° Piles	Test Variable	Moisture Content (% by Wt)	Test Temp	Fastener Torque (in.-lb)	Thickness (in.)	Width (in.)	Hole Dia (in.)	Failing Load (lb)		Strain at Failure (µin./in.)		Mode of Failure
										Individual	Average	Individual	Average	
2-4-1(1)	4A, 10A	50/40/10 Special, Panel Number 4	Stacking Sequence	NA	RT	50	0.1947	1.512	0.2512	6,520	7,025	1,895	2,116	④ · ①
2-4-1(2)										7,120	2,105	S = 167		
2-4-1(3)										7,180	2,170			
2-4-1(4)										7,280	2,295			
2-4-3	3A, 10A	50/40/10 Special, Panel Number 4	Stacking Sequence	0.74	250°F	50	0.1983	1.505	0.2494	5,700	5,080	1,610	1,481	④ · ①
2-4-9										5,200	1,560	S = 168		
2-4-8										5,040	1,520			
2-4-6										4,380	1,235			
2-5-1(1)	4A, 10A	50/40/10 Special, Panel Number 5	Stacking Sequence	NA	RT	50	0.2142	1.506	0.2511	6,330	6,393	1,845	1,921	④ · ①
2-5-1(2)										6,450	1,940	S = 53		
2-5-1(3)										6,480	1,935			
2-5-1(4)										6,390	1,965			
2-5-3	3A, 10A	50/40/10 Special, Panel Number 5	Stacking Sequence	0.87	250°F	50	0.2154	1.507	0.2498	4,000	4,185	1,235	1,214	④ · ①
2-5-9										4,500	1,350	S = 103		
2-5-8										3,720	1,150			
2-5-6										3,840	1,120			
3-12-21	3A, 10B	50/40/10	Single Shear	0.93	250°F	50	0.2240	1.505	0.2504	4,620	5,130	1,080	1,463	④ · ①
3-10-9										5,360	1,680	S = 282		
3-12-9										4,820	1,420			
3-12-23										5,700	1,670			
3-12-36	3B, 10B	50/40/10	Single Shear, e/d = 2	0.82	250°F	50	0.2115	1.504	0.2513	3,420	3,784	1,045	1,125	④ · ①
3-12-17										3,885	1,225	S = 77		
3-10-19										3,930	1,090			
3-12-34										3,900	1,140			
3-11-9(1)	4B, 10B	50/40/10	Single Shear, e/d = 2	0.92	RT	50	0.1947	1.506	0.2533	3,440	4,098	1,030	1,271	①
3-11-9(2)										4,270	1,310	S = 165		
3-11-9(3)										4,430	1,395			
3-11-9(4)										4,250	1,350			
3-1-1(1)	4A, 10B	50/40/10	Single Shear	NA	RT	50	0.2073	1.505	0.2496	7,770	6,840	2,220	1,968	④ · ①
3-1-1(2)										6,390	1,820	S = 211		
3-1-1(3)										7,160	2,060			
3-1-1(4)										6,040	1,770			

GP130115142

TABLE 1. (Continued) TENSION STRENGTH TEST DATA

Specimen Number	Specimen and Test Setup Configurations (See Figures)	Percent 0°/45°/90° Plies	Test Variable	Moisture Content (% by Wt)	Test Temp	Fastener Torque (in ft.)	Thickness (in.)	Width (in.)	Hole Dia (in.)	Failing Load (lb)		Strain at Failure (µin./in.)		Mode of Failure
										Individual	Average	Individual	Average	
3-1-16(1)	4C, 10B	50/40/10	Single Shear, w/d = 4	N/A	RT	50	0.2101	1.004	0.2504	6,740	6,265	2,795	2,633	④ - ①
3-1-16(2)										6,240	2,580	S = 132		
3-1-16(3)										6,220	2,670			
3-1-16(4)										5,850	2,485			
3-10-30(1)	4C, 10C	50/40/10	Single Shear	N/A	RT	160	0.1993	2.253	0.3780	9,140	8,549	1,715	1,706	④ - ①
3-10-30(2)										9,200	1,815			
3-10-30(3)										8,650	1,735			
3-10-30(R)(1)										7,230	1,535			
3-10-30(R)(2)							0.1896	2.260	0.3748	8,575	1,730	1,730	1,706	④ - ①
4-6-5(1)	4E, 10D	50/40/10	Thickness 40 Ply Panel	N/A	RT	50	0.4503	2.256	0.3800	21,900	21,525	1,960	1,940	①
4-6-5(2)										21,400	1,935			
4-6-5(3)										21,300	1,915			
4-6-5(4)										21,500	1,950			
4-6-15	3C, 10D	50/40/10	Thickness 40 Ply Panel	1.15	250°F	160	0.4485	2.255	0.3846	18,600	17,950	1,965	1,833	④ - ①
4-6-2										18,900	1,735			
4-6-14										17,100	1,600			
4-6-16										17,200	1,830			
4-7-5(1)	4F, 10E	50/40/10	Thickness 60 Ply Panel	N/A	RT	50	0.6511	2.254	0.3797	32,300	31,500	2,000	1,943	①
4-7-5(2)										30,900	1,920			
4-7-5(3)										32,100	1,985			
4-7-5(4)										30,700	1,865			
4-7-15	3E, 10K	50/40/10	Thickness 60 Ply Panel, e/d = 2, w/d = 4	0.88	250°F	160	0.6817	2.253	0.5621	32,500	33,750	2,330	2,259	①
4-7-2										34,500	2,260			
4-7-14										34,500	2,260			
4-7-16										33,400	2,185			
5-13-23(1)	4G, 10F	50/40/10	Countersink Hole	N/A	RT	50	0.2140	2.250	0.3777(C)	9,990	9,425	1,915	1,725	①
5-13-23(2)										9,240	1,815			
5-13-23(3)										8,620	1,590			
5-13-23(4)										9,850	1,480			
5-6-9(1)	4H, 10G	50/40/10	Countersink Hole 40 Ply Panel	N/A	RT	50	0.4519	2.249	0.3755(C)	23,300	21,500	2,200	2,034	① - ④ - ①
5-6-9(2)										20,500	1,960			
5-6-9(3)										18,900	1,800			
5-6-9(4)										23,300	2,175			

GP130115-4E

TABLE 1. (Continued) TENSION STRENGTH TEST DATA

Specimen Number	Specimen and Test Setup Configurations (See Figures)	Percent 0°/45°/90° Plys	Test Variable	Moisture Content (% by Wt)	Test Temp	Fastener Torque (in.-lb)	Thickness (in.)	Width (in.)	Hole Dia (in.)	Failing Load (lb)		Strain at Failure (µin./in.)		Mode of Failure
										Individual	Average	Individual	Average	
5-13-21(1)	4G, 10H	50/40/10	Countersunk Hole, Single Shear, Titanium	NA	RT	50	0.2020	2.253	0.3766(C)	13,900	1,310	14,919 S = 851	1,408 S = 137	④
5-13-22(1)										0.3761(C)	1,180			
5-13-21(2)										0.3748(C)	1,315			
5-13-22(2)										0.3745(C)	1,450			
5-13-21(3)										0.3752(C)	1,430			
5-13-22(3)										0.3750(C)	1,470			
5-13-21(4)										0.3752(C)	1,630			
5-13-22(4)										0.3752(C)	1,480			
5-7-9(1)	4I, 10I	50/40/10	Countersunk Hole, 60 Ply Panel	NA	RT	50	0.6501	2.255	0.3735(C)	33,400	2,190	32,925 S = 1,940	2,170 S = 140	②
5-7-9(2)										0.3749(C)	33,700			
5-7-9(3)										0.3746(C)	34,500			
5-7-9(4)										0.3748(C)	30,100			
5-1-20(1)	4G, 10J	50/40/10	Countersunk Hole, Single Shear, Aluminum	NA	RT	50	0.2099	2.257	0.3844(C)	15,500	1,400	15,188 S = 413	1,441 S = 134	④
5-13-24(1)										0.3742(C)	1,390			
5-1-20(2)										0.3749(C)	1,380			
5-13-24(2)										0.3746(C)	1,350			
5-1-20(3)										0.3751(C)	1,400			
5-13-24(3)										0.3753(C)	1,500			
5-1-20(4)										0.3752(C)	1,330			
5-13-24(4)										0.3747(C)	1,730			
6-8-1(1)	4A, 10A	50/40/10	10° Off-Axis	NA	RT	160	0.2095	1.506	0.2505	7,420	2,115	7,450 S = 173	2,179 S = 46	④
6-8-1(2)										0.2499	7,610			
6-8-1(3)										0.2502	7,550			
6-8-1(4)										0.2498	7,220			
6-8-5										0.2504	7,580			
6-8-19										0.2501	7,500			
6-8-2										0.2510	7,720			
6-8-18										0.2514	7,820			
6-8-9	0.2504	5,500												
6-8-11	3A, 10A	250°F		9.90			0.2233	1.506	0.2511	5,780	5,333	1,549 S = 163		
6-8-6										0.2121	1,508			5,020
6-8-10				0.81			0.2105	1.505	0.2510	5,030	1,510			

GP-10115-232

TABLE 1. (Continued) TENSION STRENGTH TEST DATA

Specimen Number	Specimen and Test Setup Configurations (See Figures)	Percent 0°/45°/90° Plies	Test Variable	Moisture Content (% by Wt)	Test Temp	Fastener Torque (in.-lb)	Thickness (in.)	Width (in.)	Hole Dia (in.)	Failing Load (lb)		Strain at Failure (µin./in.)		Mode of Failure
										Individual	Average	Individual	Average	
6-8-26(1)	4A, 10A	50/40/10	22.5° Off-Axis	NA	RT	50	0.2030	1.503	0.2510	7,700	7,693	2,690	2,749	① · ② · ④
6-8-26(2)										7,770	7,693	2,760	2,749	
6-8-26(3)										7,640	S = 57	2,750	S = 44	
6-8-26(4)										7,660		2,795		
6-8-22	3A, 10A	50/40/10	22.5° Off-Axis	0.81	250°F	50	0.2103	1.503	0.2511	5,950	5,615	2,195	2,076	① · ② · ④
6-8-23										6,200	5,615	2,270	2,076	
6-8-24										5,220	S = 543	1,930	S = 183	
6-8-25										5,090		1,910		
6-8-27(1)	4A, 10A	50/40/10	45° Off-Axis	NA	RT	50	0.2061	1.512	0.2511	7,430	7,515	3,800	3,865	① · ② · ④
6-8-27(2)										7,380	7,515	3,740	3,865	
6-8-27(3)										7,600	S = 130	3,930	S = 115	
6-8-27(4)										7,650		3,990		
6-8-28	3A, 10A	50/40/10	45° Off-Axis	0.76	250°F	50	0.2041	1.511	0.2514	6,080	5,513	3,185	2,945	① · ② · ④
6-8-29										5,960	5,513	3,095	2,945	
6-8-30										5,290	S = 632	2,910	S = 263	
6-8-31										4,720		2,590		
6-8-32(R)(1)	4A, 10A	50/40/10	67.5° Off-Axis	NA	RT	50	0.2128	1.506	0.2500	7,840	7,495	4,965	4,804	① · ② · ④
6-8-32(R)(2)										7,420	7,495	4,830	4,804	
6-8-33(R)(1)										7,450	S = 243	4,920	S = 164	
6-8-33(R)(2)										7,270		4,700		
6-8-34(R)(1)	4A, 10A	50/40/10	80° Off-Axis	NA	RT	50	0.2035	1.500	0.2515	7,370	7,250	4,870	4,783	① · ② · ④
6-8-34(R)(2)										7,550	7,250	5,025	4,783	
6-8-35(R)(1)										6,750	S = 347	4,395	S = 271	
6-8-35(R)(2)										7,330		4,840		

GP13-0115-233

TABLE 1. (Concluded) TENSION STRENGTH TEST DATA

Specimen Number	Specimen and Test Setup Configurations (See Figures)	Percent 0°/45°/90° Plies	Test Variable	Moisture Content (% by Wt)	Test Temp	Fastener Torque (in.-lb)	Thickness (in.)	Width (in.)	Hole Dia (in.)	Failing Load (lb)		Strain at Failure (μin./in.)		Mode of Failure
										Individual	Average	Individual	Average	
6-9-4	3A, 10A	50/40/10	90° Off-Axis	NA	RT	50	0.2031	1.509	0.2496	6,240	2,270	2,323 S = 67	③	
6-9-7							0.1991	1.502	0.2496	6,360	2,270			
6-9-8							0.2013	1.502	0.2497	6,580	2,340			
6-9-2							0.2035	1.507	0.2493	6,810	2,410			
6-9-11							0.1972	1.505	0.2503	4,820	3,780			
6-9-1							0.2070	1.509	0.2497	5,400	3,905			
6-9-10					0.2007	1.506	0.2503	4,320	3,490	3,744 S = 178				
6-9-12					0.1977	1.505	0.2499	4,570	3,800					

- Notes:
- ① (C) following hole diameter dimension indicates that hole was countersunk.
 - ② e/d = 3 for all specimens except as noted in the test variable column.
 - ③ w/d = 6 for all specimens except as noted in the test variable column.
 - ④ Mode of failure legend: ④ · ① implies a combination bearing-shearout mode of failure. * indicates that cleavage failure occurred parallel to the 0° plies.

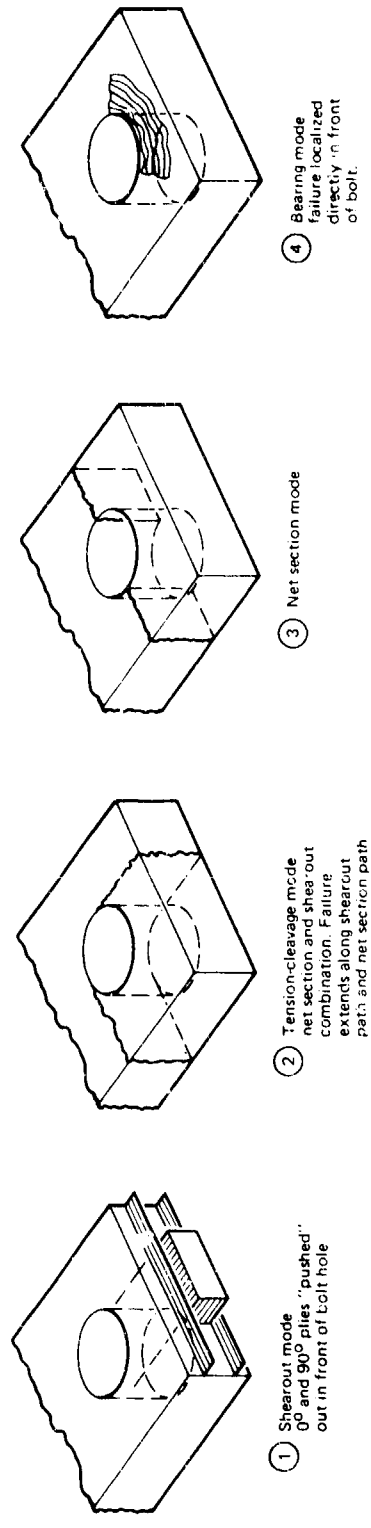

GP13-0115-234

TABLE 2. COMPRESSION STRENGTH TEST DATA

Specimen Number	Specimen and Test Setup Configurations (See Figures)	Percent 0°/45°/90° Plies	Moisture Content (% by Wt)	Test Temp	Fastener Torque (in.-lb)	Thickness (in.)	Width (in.)	Hole Dia (in.)	Failing Load (lb)		Strain at Failure (in./in.)		Mode of Failure
									Individual	Average	Individual	Average	
2-2-5	3A, 10A	50/40/10 Special Laminate Number 2	NA	RT	50	0.1934	1.506	0.2498	7,560	2,840	2,550 S = 437	④	
2-2-7						0.1928	1.507	0.2495	7,390	7,413			
2-2-4						0.2050	1.506	0.2501	7,260	1,899			
2-2-10						0.1994	1.507	0.2495	7,440	2,750			
2-3-5		50/40/10 Special Laminate Number 3	NA	RT	50	0.1826	1.505	0.2498	6,840	2,860	2,099 S = 560		
2-3-7						0.1840	1.506	0.2494	6,780	1,581			
2-3-4						0.1924	1.503	0.2486	6,600	1,800			
2-3-10						0.1945	1.503	0.2507	6,130	2,154			
2-4-5		50/40/10 Special Laminate Number 4	NA	RT	50	0.1974	1.504	0.2504	7,260	2,400	2,463 S = 69		
2-4-7						0.1942	1.505	0.2501	7,180	2,560			
2-4-4						0.1938	1.503	0.2501	6,870	2,433			
2-4-10						0.1876	1.503	0.2504	6,740	2,460			
2-5-5	50/40/10 Special Laminate Number 5	NA	RT	50	0.2150	1.505	0.2505	7,520	2,680	2,538 S = 176			
2-5-7					0.2144	1.505	0.2505	7,460	2,680				
2-5-4					0.2024	1.506	0.2501	6,830	2,320				
2-5-10					0.2024	1.502	0.2501	6,880	2,470				
4-6-6	3C, 10D		NA	RT	160	0.4627	2.254	0.3855	24,150	2,120	2,327 S = 200 Omits 4-6-3		
4-6-10						0.4545	2.255	0.3748	25,500	2,340			
4-6-11						0.4545	2.255	0.3756	25,900	2,520			
4-6-3						0.4757	2.256	0.3833	21,900	2,130			
4-6-7		Thickness 40 Ply Laminate	1.15	RT	0	0.4675	2.255	0.3777	22,000	2,060	1,795 S = 219		
4-6-8						0.4636	2.253	0.3754	19,200	1,610			
4-6-4						0.4760	2.259	0.3777	17,800	1,620			
4-6-12						0.4601	2.255	0.3759	18,300	1,890			
4-7-6		3D, 10E		NA	RT	160	0.6931	2.255	0.3746	34,500	2,245	3,252 S = 129 Omits 4-7-6	
4-7-10							0.6870	2.258	0.5640	54,200	3,270		
4-7-11							0.6877	2.256	0.5625	55,500	3,175		
4-7-3							0.6912	2.257	0.5624	58,300	3,430		
4-7-7	3E, 10K	50/40/10	0.86	RT	160	C 5927	2.255	0.5624	46,700	2,730	2,620 S = 92		
4-7-8						0.6	3	2.258	0.5622	44,700		2,520	
4-7-4						0.68	1	2.255	0.5622	44,900		2,575	
4-7-12						0.6790	2.259	0.5620	43,450	2,655			

GP13-2116-144

TABLE 2. (Concluded) COMPRESSION STRENGTH TEST DATA

Specimen Number	Specimen and Test Setup Configurations (See Figures)	Percent 0°/45°/90° Plies	Test Variable	Moisture Content (% by Wt)	Test Temp	Fastener Torque (in.-lb)	Thickness (in.)	Width (in.)	Hole Dia (in.)	Failing Load (lb)		Strain at Failure (µin./in.)		Mode of Failure
										Individual	Average	Individual	Average	
6-8-8	3A, 10A	50°/40°/10°	10° Off Axis	NA	R*	50	0.2223	1.506	0.2504	8,130	2,880	④		
6-8-12							0.2256	1.506	0.2502	8,040	2,550			
6-8-13							0.2225	1.507	0.2500	8,000	2,570			
6-8-4							0.2192	1.502	0.2500	7,690	2,550			
6-8-7							0.2213	1.507	0.2505	8,200	3,270			
6-8-15							0.2223	1.505	0.2515	8,120	2,710			
6-8-21							0.2220	1.507	0.2514	8,060	2,586			
6-8-17							0.2248	1.507	0.2520	8,330	2,757			
6-8-20							0.2217	1.505	0.2507	5,620	1,900			
6-8-16							0.2265	1.507	0.2525	5,960	2,175			
6-8-3							0.2177	1.508	0.2512	5,900	1,875			
6-8-14							0.2072	1.506	0.2511	6,000	1,950			

Notes:

- ① (C) following hole diameter dimension indicates that hole was countersunk.
- ② e/d = 3 for all specimens except as noted in the test variable column
- ③ e/d = 6 for all specimens except as noted in the test variable column.
- ④ Mode of failure legend
- ① implies a combination bearing-shear mode of failure.
- * indicates that cleavage failure occurred parallel to the 0° plies.

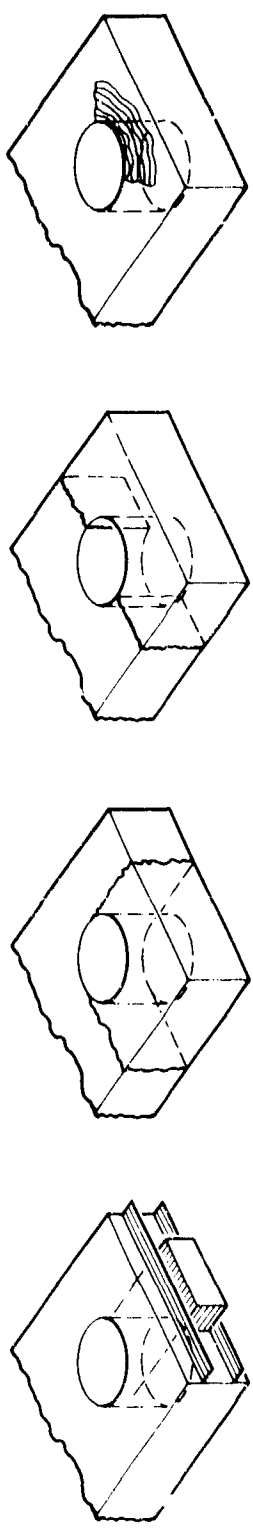

- ① Shearout mode 0° and 90° plies "pushed" out in front of bolt hole
- ② Tension-cleavage mode net section and shearout combination. Failure extends along shearout path and net section path
- ③ Net section mode
- ④ Bearing mode failure localized directly in front of bolt

GP-13-8116-341

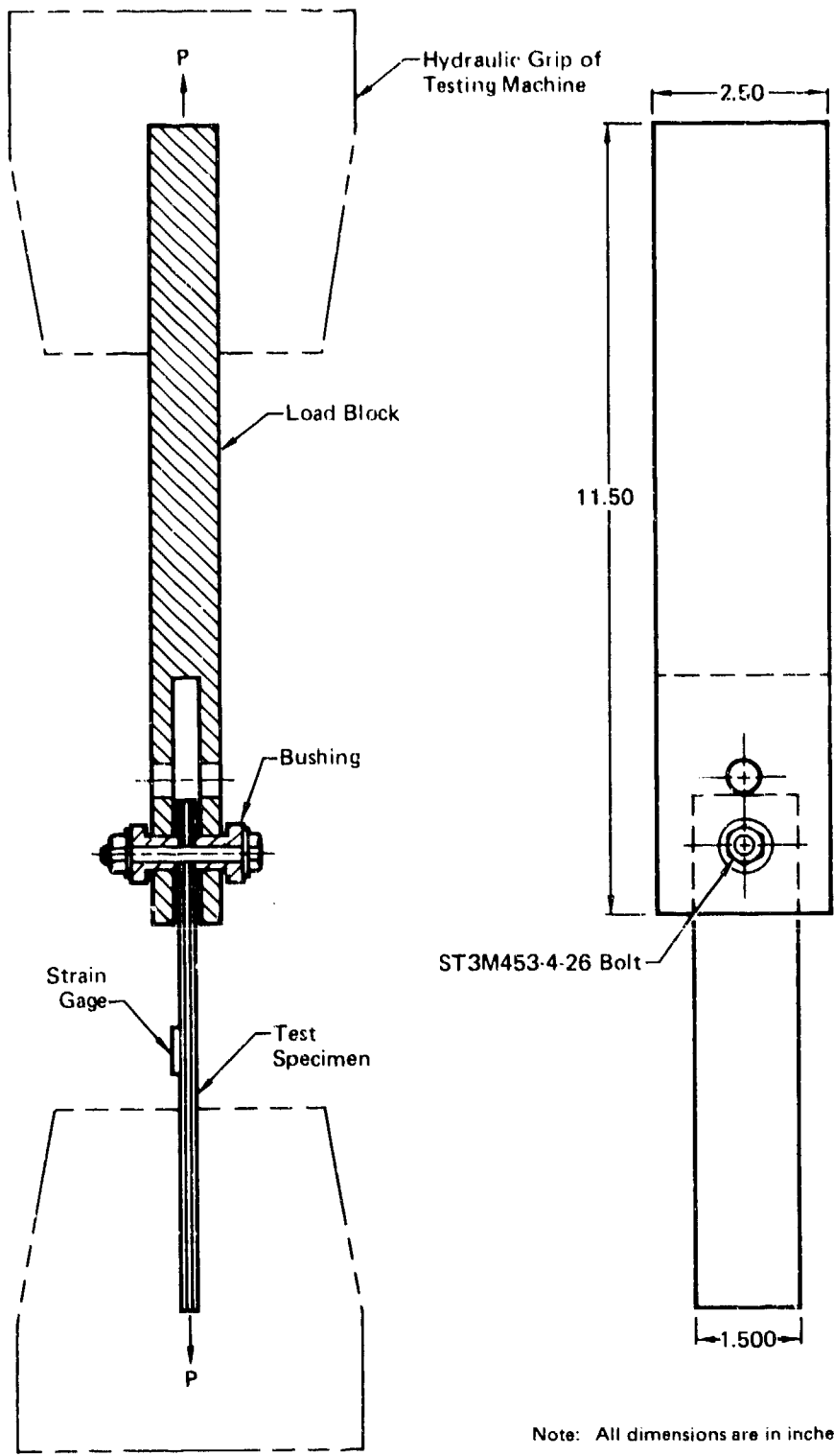

Note: All dimensions are in inches.
GP13-0115-145

Test Configuration 10A

Figure 10. Single Fastener Test Setups

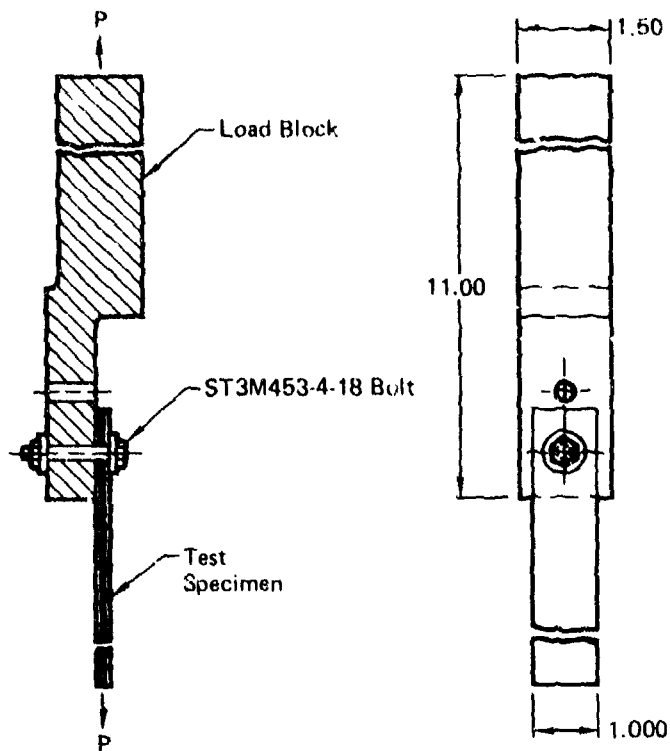

Test Configuration 10B

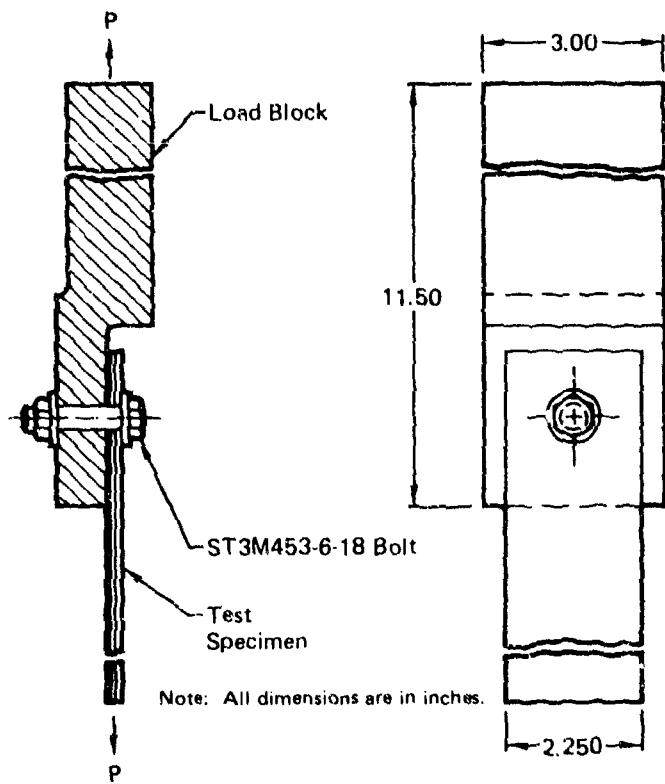

Note: All dimensions are in inches.

Test Configuration 10C

QP13-0115-148

Figure 10 (Continued) Single Fastener Setups

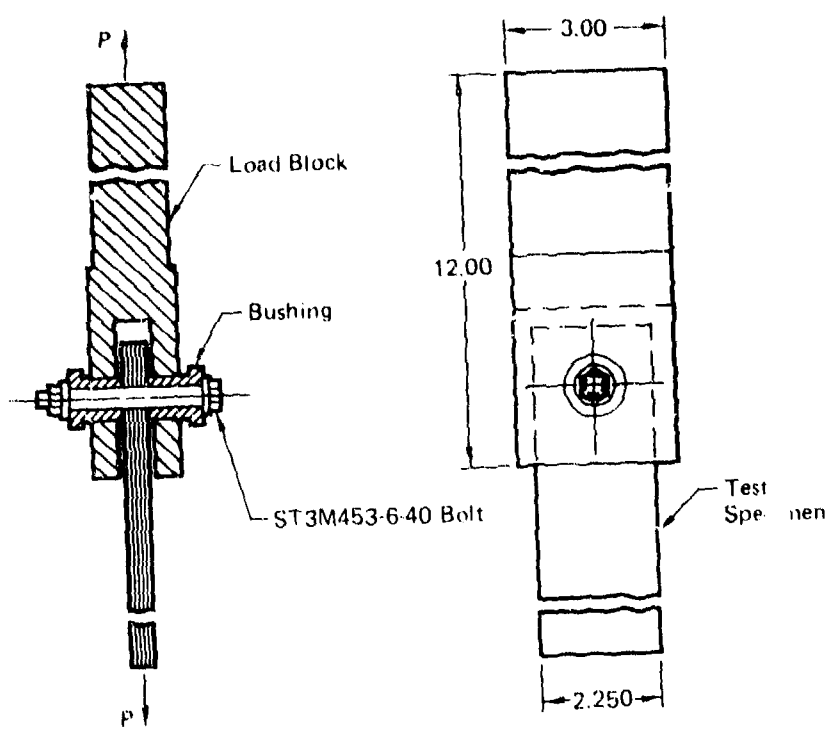

Test Configuration 10D

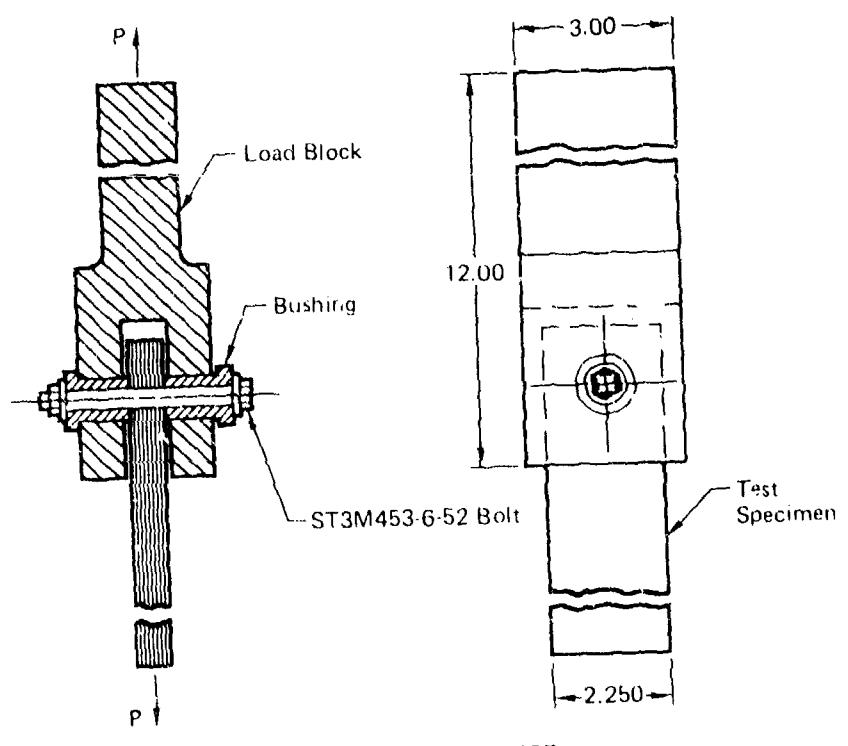

Test Configuration 10E

Note: Dimensions are in inches.

GP13-0115-229

Figure 10. (Continued) Single Fastener Test Setups

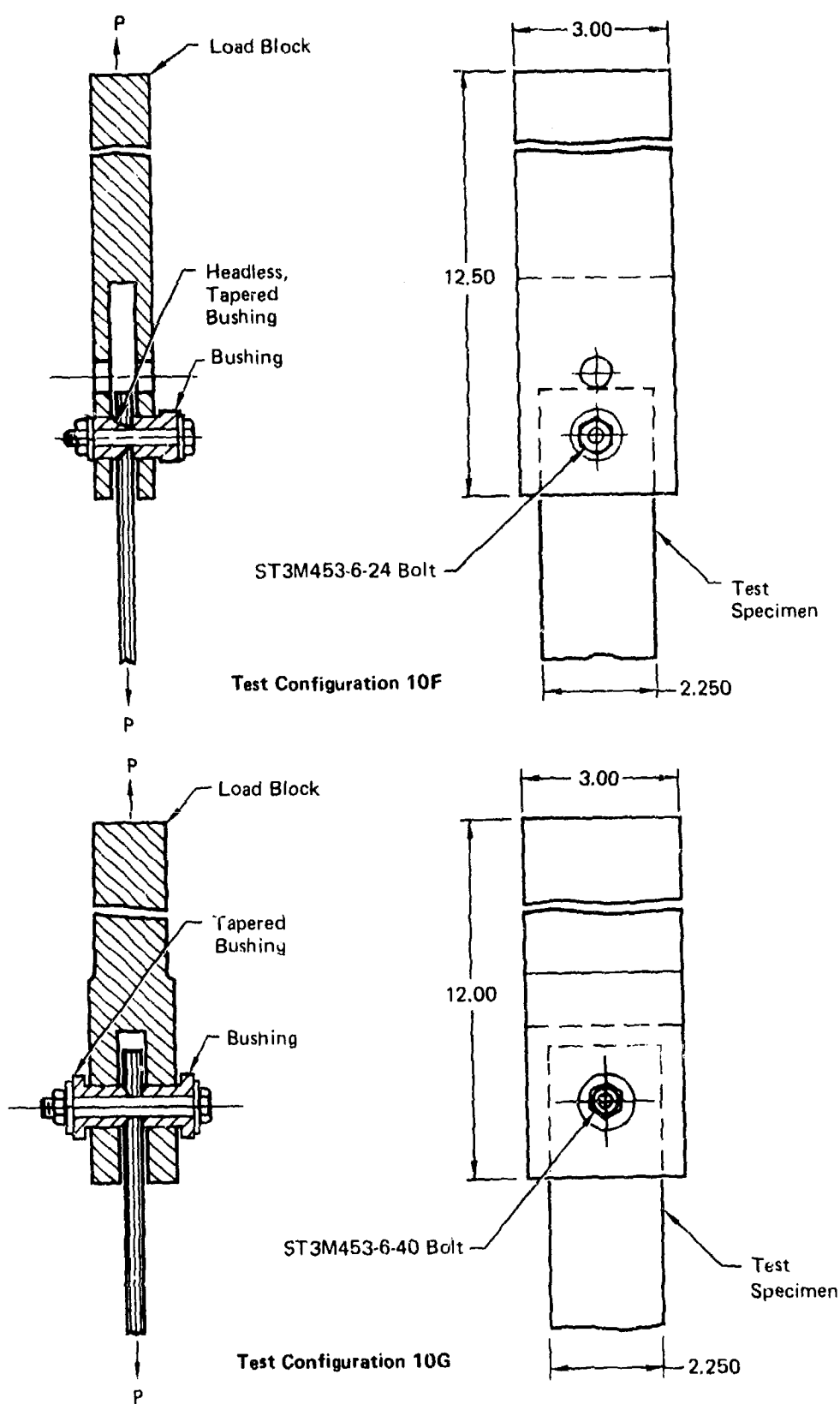
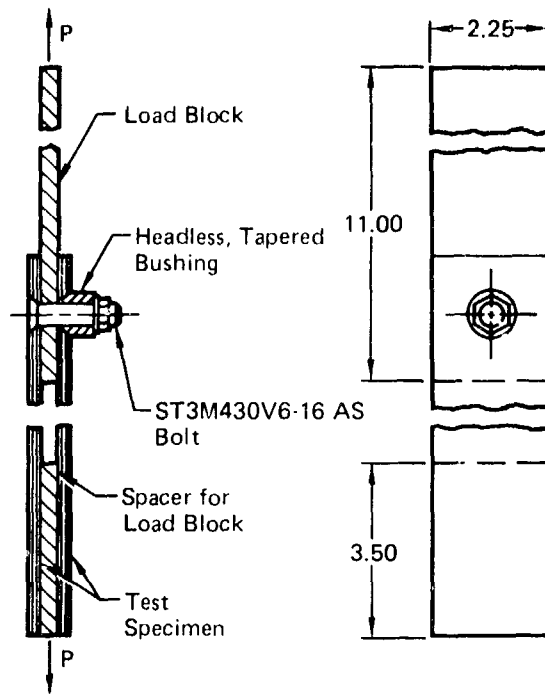
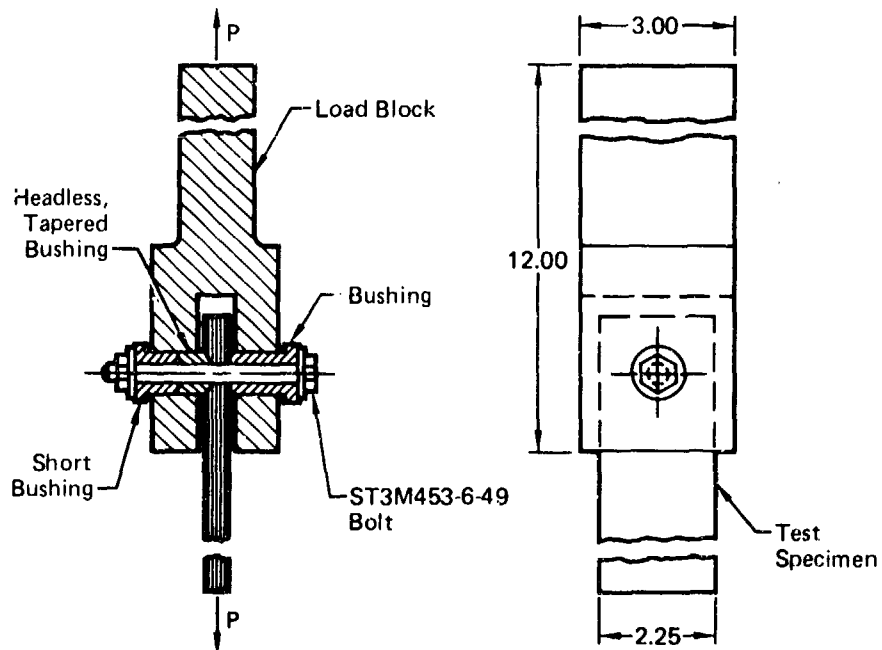

Figure 10. (Continued) Single Fastener Test Setups

GP13-0115-147



Test Configuration 10H



Test Configuration 10I

Note: All dimensions are in inches.

GP13-0115-281

Figure 10. (Continued) Single Fastener Test Setups

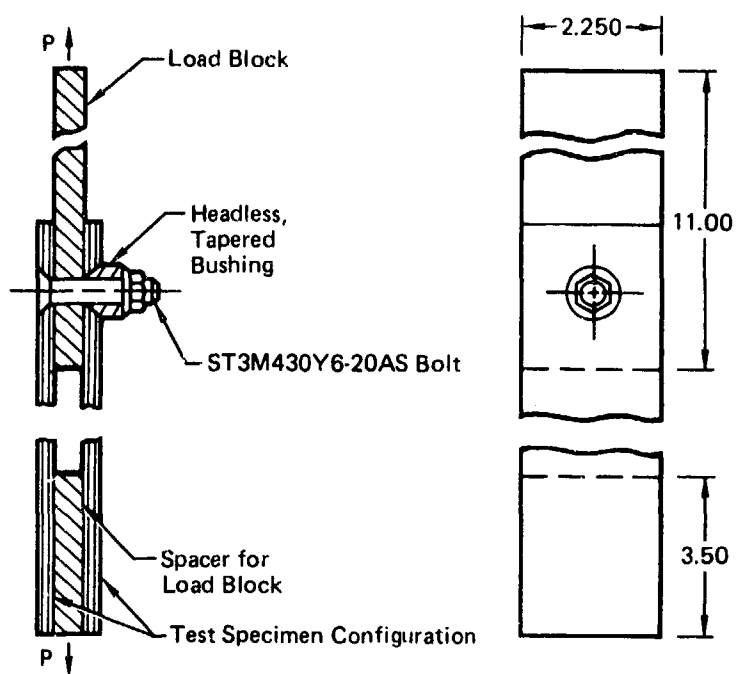

Test Configuration 10J

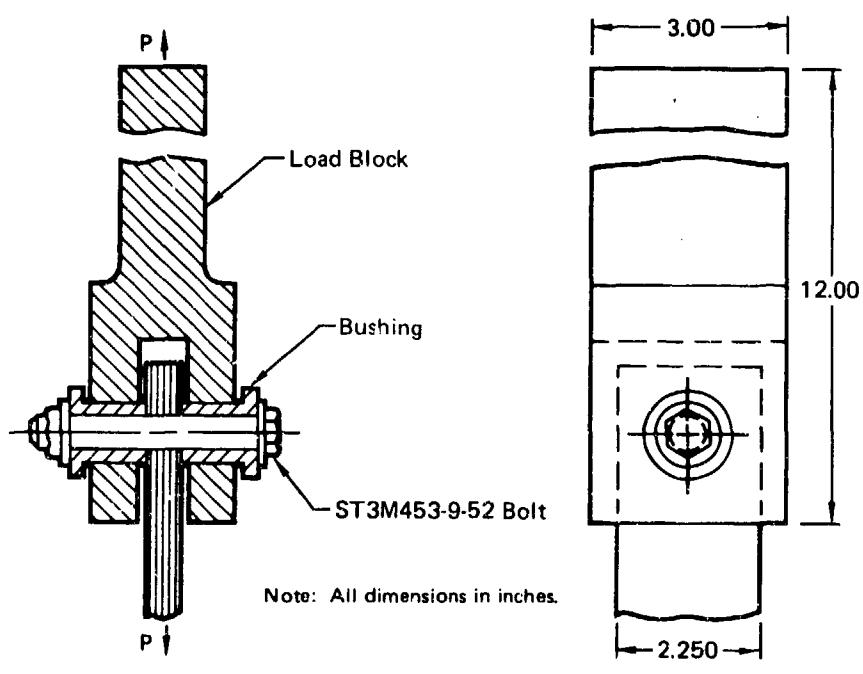

Note: All dimensions in inches.

Test Configuration 10K

GP13-0115-148

Figure 10. (Continued) Single Fastener Test Setups

Specimen Number 2-3-1

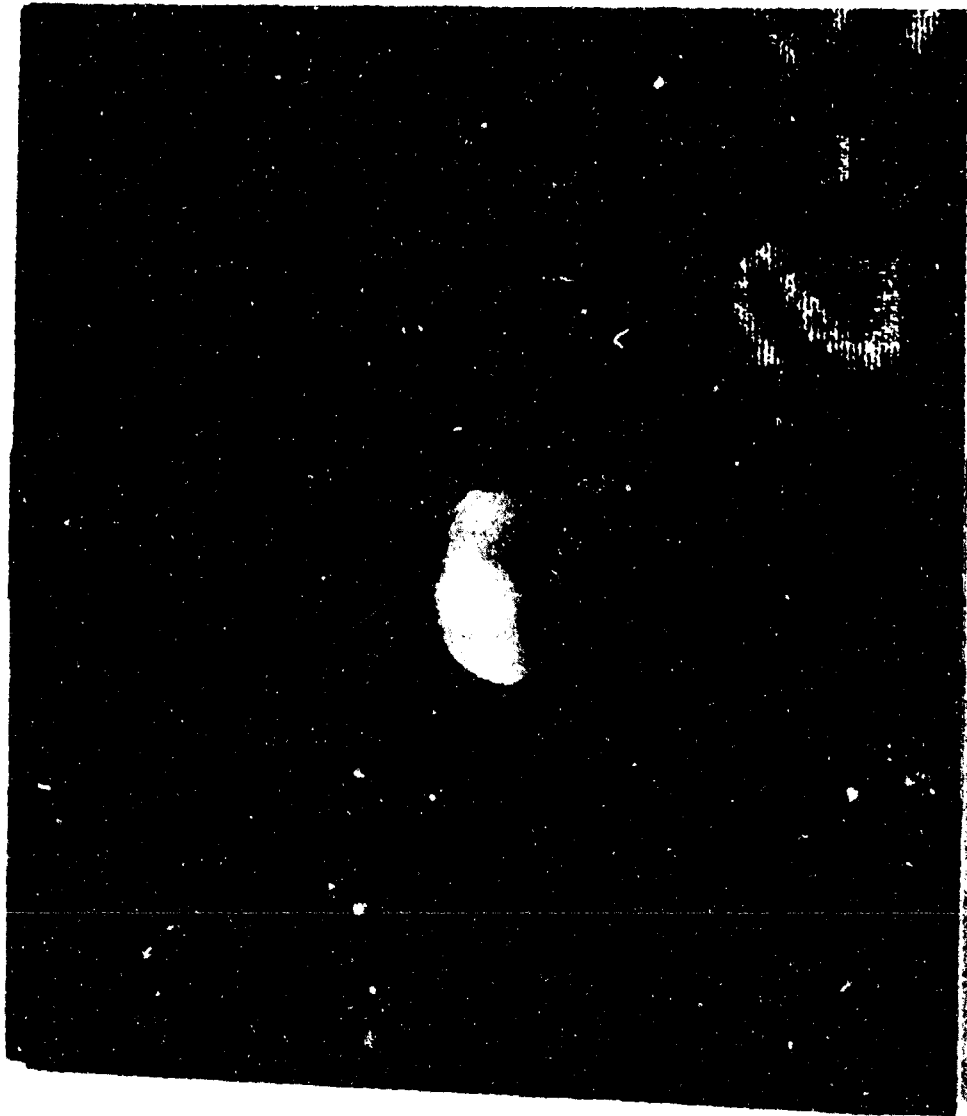

Plan View of Failure



Edge View of Failure

GP13-0115-140

Figure 11. Bearing Mode of Failure

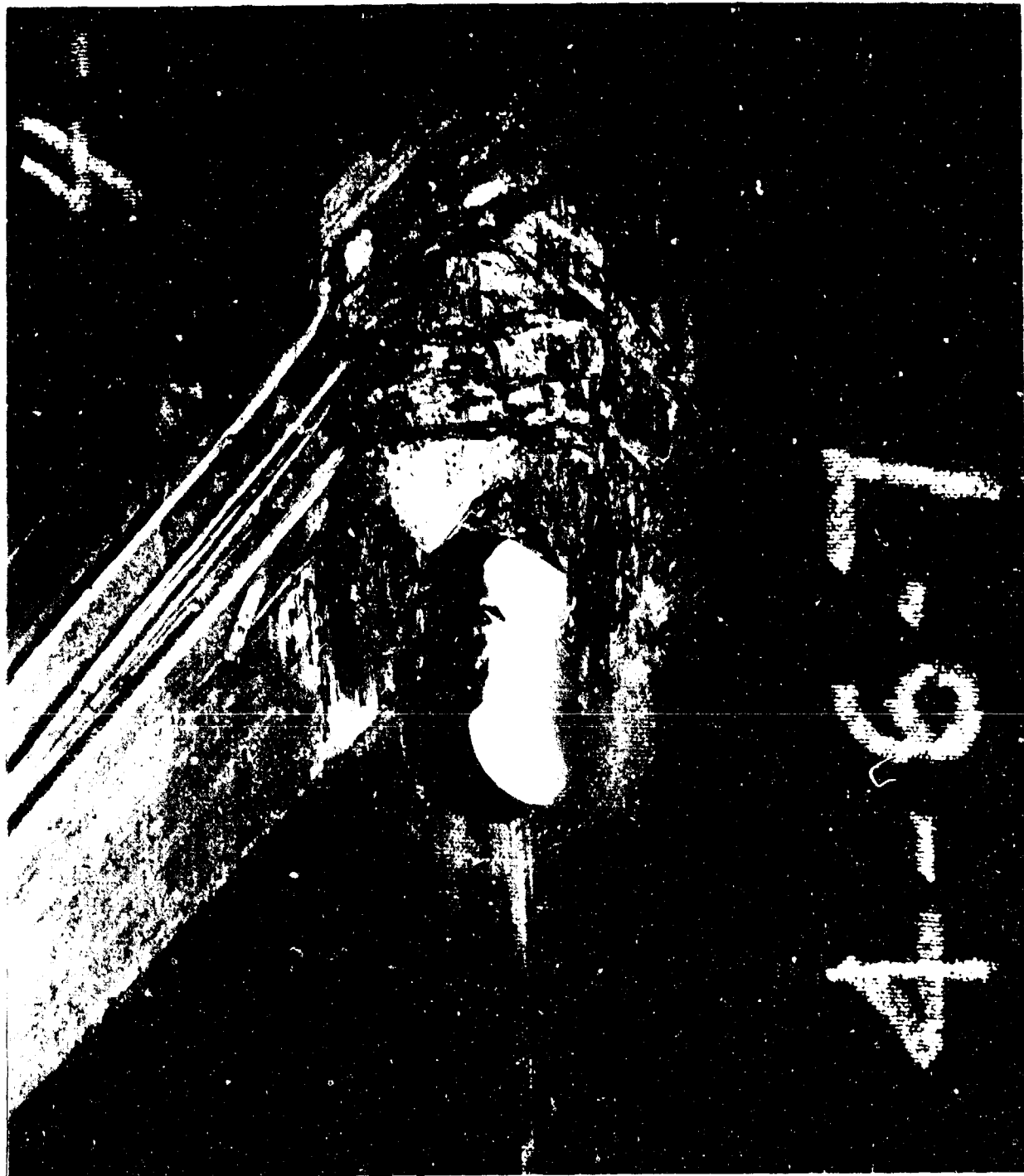

QP13-0115-150

Figure 12. Bearing Mode of Failure (40 Ply)

Specimen Number 2-5-6

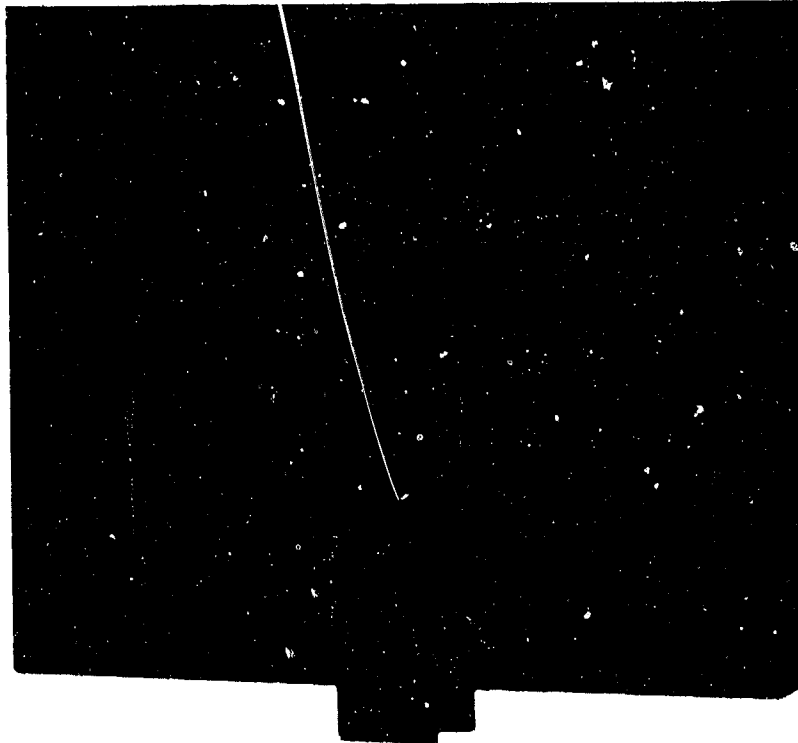

Plan View of Failure

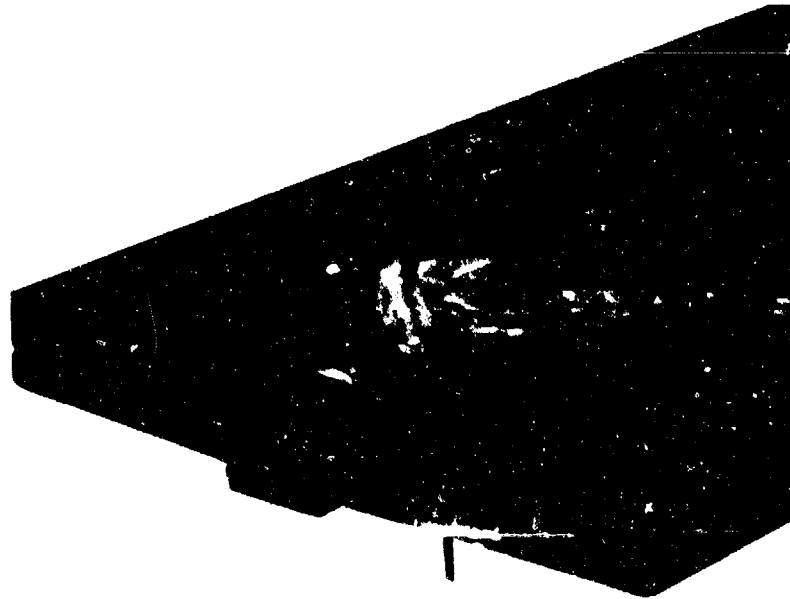

Edge View of Failure

GP13-0115-151

Figure 13. Bearing-Shearout Mode of Failure

Specimen Number 4-6-14

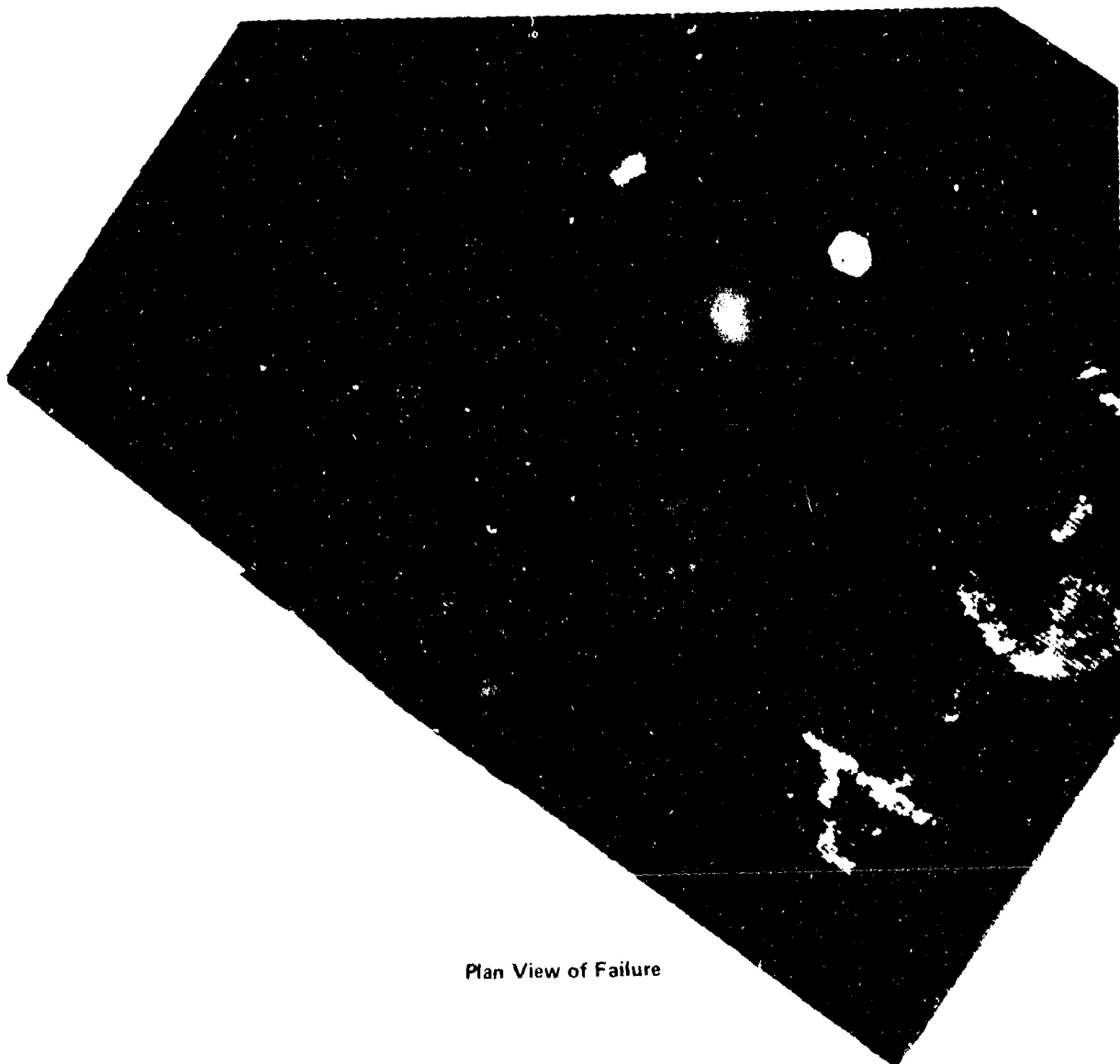

Plan View of Failure

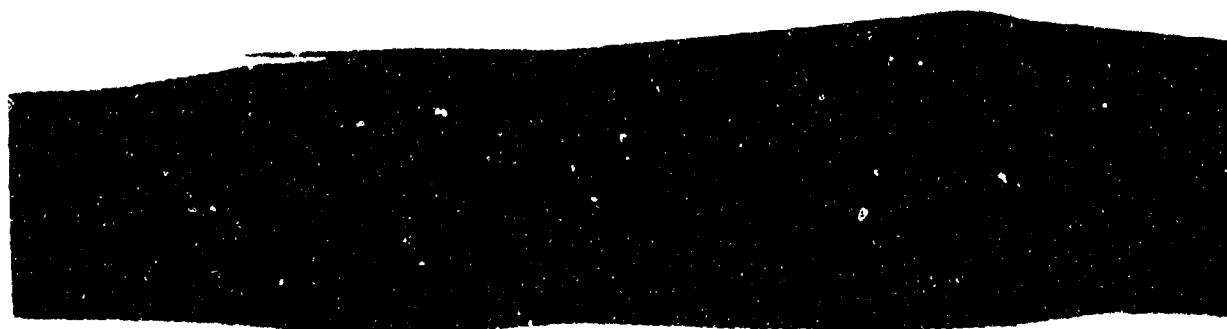

Edge View of Failure

GP13-0116-152

Figure 14. Bearing-Shearout Mode of Failure



Plan View of Failure

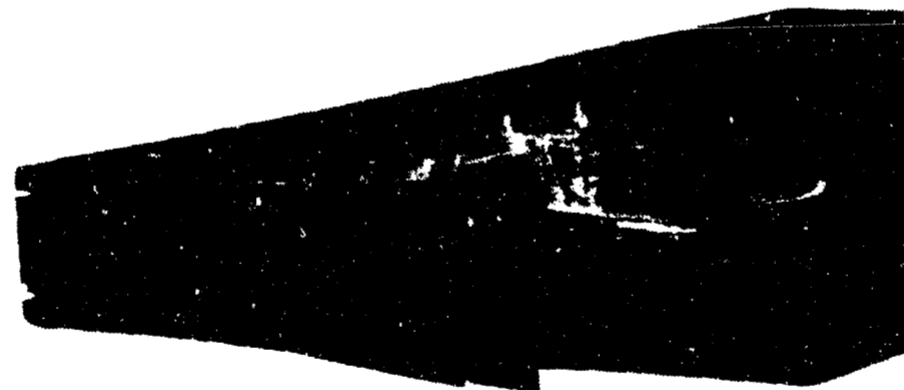

Edge View of Failure

QP13-0115-153

Figure 15. Bearing-Shearout Mode of Failure
10° Off Axis Test



Plan View of Failure



Edge View of Failure

GP13-0115-154

Figure 16. Shearout-Tension-Cleavage Mode of Failure
22.5° Off Axis Test

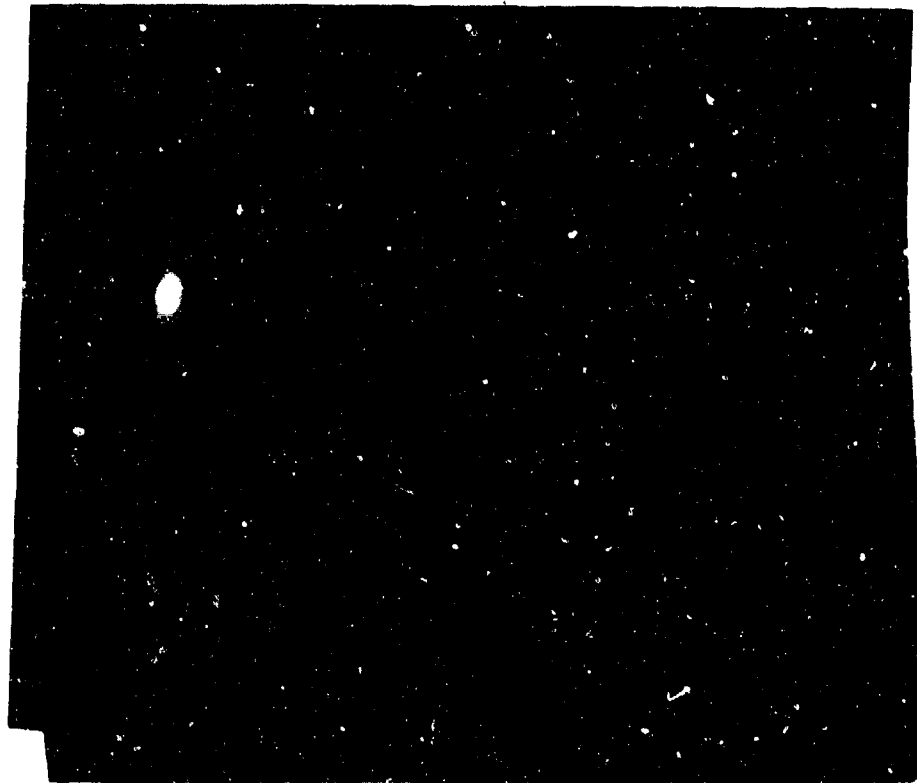

Plan View of Failure

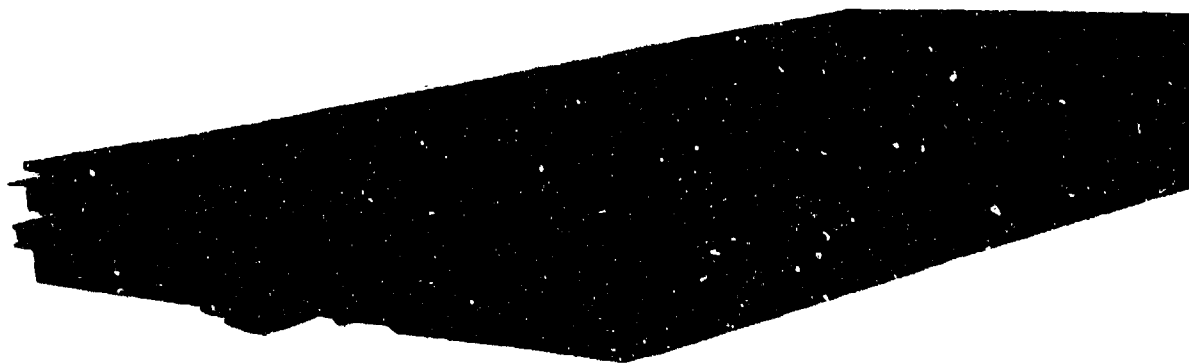

Edge View of Failure

GP13-0115-155

Figure 17. Bearing-Shearout-Tension-Cleavage Mode of Failure
45° Off Axis Test



GP13-0115-156

**Figure 18. Shearout-Tension-Cleavage Mode of Failure
67.5° Off Axis Test**

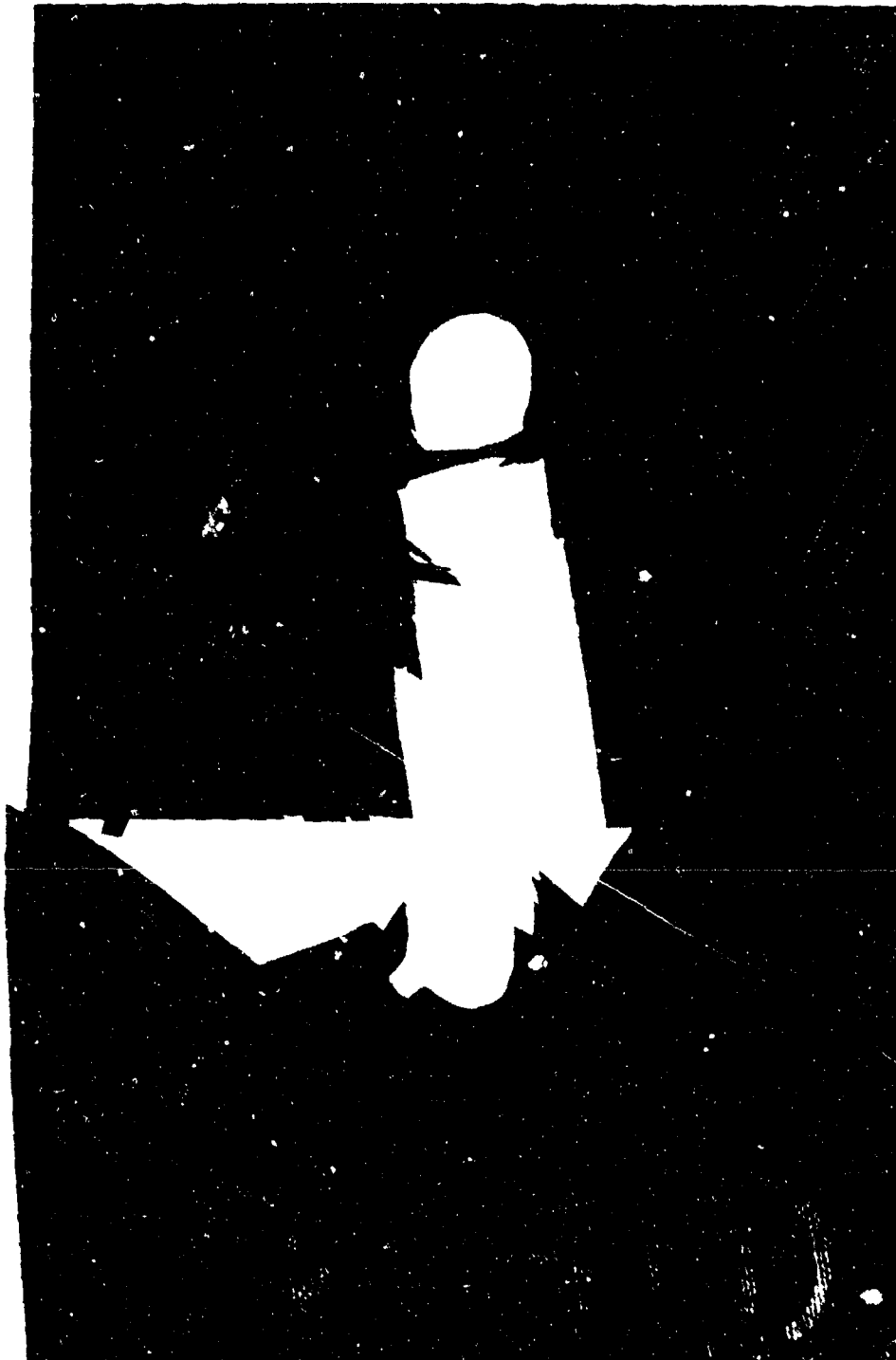

GP13-0115-157

Figure 19. Shearout-Tension-Cleavage Mode of Failure
80° Off Axis Test



GP13-0115-158

Figure 20. Bearing-Net Section Mode of Failure
90° Off Axis Test

TABLE 3. TENSION STRENGTH TEST DATA

Specimen Number	Specimen and Test Setup Configurations (See Figures)	Percent 0°/45°/90° Plies	Test Variable	Moisture Content (% by Wt)	Test Temp	Fastener Torque (in.-lb)	Thickness (in.)	Width (in.)	Hole Dia (in.)	Failing Load (lb)		Strain at Failure (μin./in.)		Mode of Failure
										Individual	Average	Individual	Average	
1-10-24(1)	4J, 21A	50/40/10	Fastener Torque	NA	RT	0	0.2133	1.501	0.2514 0.2505 0.2501 0.2502 0.2495 0.2497 0.2497 0.2495	10,780	12,360	3,135	3,668 S = 4E5	A
1-10-24(2)										17,500	S = 1,368			
1-10-24(3)										15,160	S = 1,160			
1-10-24(4)										13,140	1-10-24(2)			
1-1-31(1)	3F, 21A	50/40/10	Fastener Torque	NA	RT	25	0.2326	1.505	0.2511 0.2513 0.2510 0.2503 0.2500 0.2496 0.2495 0.2496	13,395	14,114	3,635	3,933 S = 306	4 - 1
1-1-31(2)										13,380	S = 919			
1-1-31(3)										15,300	S = 919			
1-1-31(4)										14,380	S = 919			
1-12-4	3F, 21A	50/40/10	Fastener Torque	0.77	250°F	0	0.2003	1.504	0.2507 0.2553 0.2502 0.2513 0.2527 0.2510 0.2530 0.2534	9,730	9,375	2,715	2,701 S = 194	4 - 1
1-10-1										8,970	S = 874			
1-12-28										8,400	S = 874			
1-1-8										10,400	S = 874			
3-11-7(1)	4J, 21G	50/40/10	Single Shear	0.75	RT	50	0.1966	1.507	0.2492 0.2494 0.2497 0.2498 0.2495 0.2495 0.2499 0.2500	10,100	11,640	3,485	3,358 S = 305	4 - 1
3-11-7(2)										11,650	S = 1,253			
3-11-7(3)										11,640	S = 1,253			
3-11-7(4)										13,170	S = 1,253			
3-10-2	3F, 21G	50/40/10	Single Shear	0.86	RT	50	0.1984	1.504	0.2506 0.2522 0.2518 0.2511 0.2517 0.2505 0.2510 9 2512	12,360	12,335	3,770	3,685 S = 271	4 - 1
3-10-6										11,050	S = 904			
3-10-21										12,900	S = 904			
3-10-23										13,030	S = 904			
3-12-18	4K, 21B	50/40/10	Hole Size	0.91	250°F	50	0.2187	1.505	0.2500 0.2508 0.2532 0.2534 0.2507 0.2517 0.2573 0.2527	10,290	10,408	2,950	3,096 S = 237	4 - 1
3-12-30										10,780	S = 506			
3-12-3										10,820	S = 506			
3-12-13										9,740	S = 506			
7-10-32(1)	4L, 21C	50/40/10	Hole Size	0.81	RT	160	0.198E	3.007	0.5037 0.5026 0.4996 0.500 0.5024 0.500 0.4995 0.500	22,500	21,475	3,215	3,113 S = 335	4 - 1
7-10-32(2)										22,700	S = 2,455			
7-10-35(1)										17,800	S = 2,455			
7-10-35(2)										22,900	S = 2,455			
7-1-18(1)	4L, 21C	50/40/10	Hole Size	NA	RT	160	0.2155	2.259	0.3762 0.3742 0.3745 0.3748 0.3749 0.3746 0.3748 0.3748	18,000	19,394	3,220	3,463 S = 167	4 - 1
7-1-18(2)										18,900	S = 1,246			
7-1-18(R)(1)										19,750	S = 1,246			
7-1-18(R)(2)										20,925	S = 1,246			

OPT126115-1B

TABLE 3. (Continued) TENSION STRENGTH TEST DATA

Specimen Number	Specimen and Test Setup Configurations (See Figures)	Percent 0°/45°/90° Plies	Test Variable	Moisture Content (% by Wt)	Test Temp	Fastener Torque (in. lb)	Thickness (in.)	Width (in.)	Hole Dia (in.)	Failing Load (lb)		Strain at Failure (μ in./in.)		Mode of Failure
										Individual	Average	Individual	Average	
7-10-33(1)	4M, 21D	50/40/10	Hole Size	NA	RT	50	0.2166	1.131	0.1872	9,500	3,740	3,677	④ - ①	
7-10-33(2)										9,460	3,705	④		
7-10-33(3)										9,520	3,585	④		
7-10-33(4)										⑧	⑧	⑧		
8-11-1(1)	4N, 21A	Edge Distance, e/d = 2	Edge Distance, e/d = 2	NA	RT	50	0.1955	1.504	0.2501	10,220	3,045	3,263	④ - ①	
8-11-1(2)										10,800	3,205	④		
8-11-1(3)										11,270	3,420	④		
8-11-1(4)										11,060	3,380	④		
8-11-11(1)	4P, 21A	Edge Distance, e/d = 4	Edge Distance, e/d = 4	NA	RT	50	0.1958	1.503	0.2501	14,420	4,365	4,255	④ - ①	
8-11-11(2)										13,200	4,115	④		
8-11-11(3)										14,000	4,420	④		
8-11-11(4)										13,380	4,120	④		
8-11-5(1)	4D, 21A	Edge Distance, e/d = 1.5	Edge Distance, e/d = 1.5	NA	RT	50	0.1960	1.503	0.2493	8,760	2,620	2,806	①	
8-11-5(2)										9,520	2,870	①		
8-11-5(3)										9,390	2,855	①		
8-11-5(4)										9,040	2,880	①		
8-1-14(1)	4R, 21E	50/40/10	Edge Distance, 3D Hole Spacing	NA	RT	50	0.2241	1.506	0.2510	12,680	3,445	3,756	②	
8-1-14(2)										13,800	3,850	②		
8-1-14(3)										13,760	3,680	②		
8-1-14(4)										14,600	4,050	②		
8-1-4(1)	4S, 21F	Edge Distance, 2D Hole Spacing	Edge Distance, 2D Hole Spacing	NA	250°F	50	0.2131	1.508	0.2497	12,180	3,400	3,491	②	
8-1-4(2)										12,440	3,480	②		
8-1-4(3)										12,460	3,485	②		
8-1-4(4)										12,350	3,600	②		
8-1-11	3G, 21A	Edge Distance, e/d = 2	Edge Distance, e/d = 2	0.93	250°F	50	0.2310	1.508	0.2523	11,480	3,270	2,841	①	
8-12-33										11,260	3,125	①		
8-12-2										8,460	2,450	④ - ①		
8-11-8										8,460	2,520	④ - ①		
8-10-3	3H, 21A	Edge Distance, e/d = 4	Edge Distance, e/d = 4	0.76	250°F	50	0.1990	1.503	0.2516	10,480	3,105	3,119	④	
8-10-5										11,040	3,420	④		
8-12-22										10,260	3,090	④ - ①		
8-12-15										10,000	2,860	④ - ①		

GP13-0115-100

TABLE 3. (Continued) TENSION STRENGTH TEST DATA

Specimen Number	Specimen and Test Setup Configurations (See Figures)	Percent 0°/45°/90° Plies	Test Variable	Moisture Content (% by Wt)	Test Temp	Fastener Torque (in.-lb)	Thickness (in.)	Width (in.)	Hole Dia (in.)	Failing Load (lb)		Strain at Failure (μ in./in.)		Mode of Failure		
										Individual	Average	Individual	Average			
8-1-13				0.92			0.2307	1.511	0.2497	9.2500	9.120	2.380		①		
8-10-22	3I, 21A		Edge Distance, e/d = 1.5	0.95	250°F	50	0.2129	1.501	0.2496	0.2486	9.010	2.630	2.348	④ · ①		
8-11-10				0.78			0.1968	1.501	0.2498	0.2502	7.370	2.230	S = 1,104		2.150	
8-12-8				0.89			0.2151	1.504	0.2501	0.2501	6.980	2.105	3.154		3.372	S = 439
8-10-7				0.79			0.2055	1.503	0.2519	0.2523	10.330	2.750	2.562		2.519	S = 228
8-1-15	3J, 21E	50/40/10	Edge Distance, 30 Hole Spacing	0.94	250°F	50	0.2295	1.506	0.2529	0.2513	12.500	10.753	3.154	④ · ①		
8-10-18				0.86			0.2108	1.505	0.2515	0.2504	11.700	2.665	2.660		S = 228	
8-12-10				0.80			0.2064	1.505	0.2532	0.2532	8.480	2.400	2.400		2.400	
8-1-7				0.84			0.2115	1.507	0.2517	0.2505	9.330	5.050	4.705		4.705	
8-10-26	3K, 21F		Edge Distance, 20 Hole Spacing	0.87	RT	50	0.2115	1.503	0.2512	0.2512	8.920	8.653	2.519	④ · ① · ⑤		
8-12-20				0.95			0.2228	1.505	0.2522	0.2520	7.560	2.660	2.660		S = 228	
8-1-10				0.97			0.2285	1.515	0.2506	0.2498	8.800	2.400	2.400		2.400	
9-10-28(1)									0.2514	0.2525	11.430	5.050	4.705		4.705	
9-10-28(2)	4T, 21A		Width, w/d = 4	NA	RT	50	0.2110	1.004	0.2501	0.2494	10.720	10.510	4.705	③		
9-10-28(3)							0.2502	0.2502	9.790	S = 725	4.500	S = 244				
9-10-28(4)							0.2498	0.2498	10.100	4.570	4.335	4.466				
9-10-31(1)							0.2496	0.2512	12.800	4.335	4.335	4.466				
9-10-31(2)	4U, 21A		Width, w/d = 5	NA	RT	50	0.2158	1.253	0.2496	0.2503	12.880	12.760	4.466	③		
9-10-31(3)							0.2506	0.2500	12.600	S = 118	4.475	S = 92				
9-10-31(4)							0.2502	0.2497	12.760	4.540	2.875	2.959				
9-19-8(1)							0.2520	0.2527	13.200	2.875	3.085	2.959				
9-19-8(2)	4V, 21A	50/40/10	Width, w/d = 8	0.73	RT	50	0.2114	2.004	0.2498	0.2503	13.940	13.535	2.959	④ · ①		
9-19-8(3)							0.2500	0.2503	13.700	S = 346	3.015	S = 109				
9-19-8(4)							0.2495	0.2495	13.300	2.860	2.860	2.959				
9-13-9							0.2143	2.000	0.2552	0.2487	10.440	2.340	2.340		2.340	
9-13-10	3L, 21A		Width, w/d = 8	0.85	250°F	50	0.2159	2.005	0.2518	0.2534	10.820	10.310	2.318	④ · ①		
9-13-11				0.75			0.2164	2.004	0.2520	0.2505	8.020	1.850	S = 345			
9-13-12				0.86			0.2139	2.006	0.2523	0.2523	11.560	2.680	2.680		2.680	
9-13-5				0.72			0.1951	1.251	0.2503	0.2524	10.230	3.690	3.690		3.690	
9-13-6	3M, 21A		Width, w/d = 5	0.82	RT	50	0.2053	1.255	0.2535	0.2500	11.540	10.498	3.828	④ · ①		
9-13-7				0.75			0.1974	1.250	0.2499	0.2538	10.120	3.600	S = 264			
9-13-8				0.86			0.2073	1.254	0.2489	0.2488	10.100	3.820	3.820		3.820	

GP130115.101

TABLE 3. (Continued) TENSION STRENGTH TEST DATA

Specimen Number	Specimen and Test Setup Configurations (See Figures)	Percent 0°/45°/90° Plies	Test Variable	Moisture Content (% by Wt)	Test Temp	Fastener Torque (in.-lb)	Thickness (in.)	Width (in.)	Hole Dia (in.)	Failing Load (lb)		Strain at Failure (μin./in.)		Mode of Failure
										Individual	Average	Individual	Average	
9-13-1	3N, 21A	50/40/10	Width, w/d = 4	0.74	250°F	50	0.1941	1.001	0.2498	0.2500	9,650	4,215	4,295 S = 360	④ · ①
9-13-2				0.1988			1.005	0.2542	0.2503	11,040	4,760			
9-13-3				0.1923			0.958	0.2521	0.2505	8,840	3,890			
9-13-4				0.2004			1.004	0.2497	0.2497	9,480	4,330			
10-10-16 (1)	4J, 21A	50/40/10	Width, w/d = 4	NA	RT	50	0.2082	1.502	0.2514	0.2509	12,840	3,780	3,889 S = 140	④ · ①
10-10-16 (2)							0.2086	1.505	0.2498	0.2505	13,660	4,055		
10-10-16 (3)							0.2071	1.504	0.2497	0.2503	13,450	4,040		
10-10-16 (4)							0.2043	1.490	0.2497	0.2495	13,780	4,080		
10-12-16	3F, 21A	50/40/10	Width, w/d = 4	0.81	RT	50	0.2086	1.505	0.2501	0.2485	12,600	3,715	3,894 S = 251	①
10-12-31							0.2007	1.504	0.2541	0.2537	12,600	3,800		
10-12-25							0.2071	1.505	0.2541	0.2532	12,800	3,795		
10-10-8							0.2043	1.490	0.2504	0.2504	14,100	4,265		
10-12-27	4J, 21A	70/20/10	Layout	0.88	RT	50	0.2134	1.496	0.2513	0.2501	11,200	3,330	3,076 S = 323	④ · ①
10-12-1							0.1993	1.500	0.2504	0.2503	10,700	3,325		
10-12-7							0.2050	1.500	0.2545	0.2540	9,000	2,650		
10-10-17							0.2106	1.504	0.2513	0.2505	9,880	3,000		
10-14-1 (1)	3F, 21A	70/20/10	Layout	0.73	250°F	50	0.1867	1.501	0.2530	0.2497	8,040	1,930	2,101 S = 143	①
10-14-1 (2)							0.1867	1.504	0.2512	0.2503	6,140	2,045		
10-14-1 (3)							0.1913	1.496	0.2522	0.2530	6,460	2,255		
10-14-1 (4)							0.1865	1.504	0.2507	0.2503	4,820	2,175		
10-14-14	4J, 21A	30/60/10	Layout	0.73	RT	50	0.1867	1.504	0.2512	0.2503	6,140	1,415	5,468 S = 189	③
10-14-2							0.1913	1.496	0.2522	0.2530	6,460	1,460		
10-14-13							0.1865	1.504	0.2507	0.2503	4,820	1,190		
10-14-15							0.1883	1.505	0.2495	0.2503	5,550	1,300		
10-15-1 (1)	3F, 21A	30/60/10	Layout	0.93	RT	50	0.2142	1.507	0.2521	0.2514	13,000	5,310	4,705 S = 562	④
10-15-1 (2)							0.2142	1.507	0.2504	0.2498	13,050	5,300		
10-15-1 (3)							0.2142	1.507	0.2503	0.2496	13,640	5,660		
10-15-1 (4)							0.2142	1.507	0.2497	0.2495	13,380	5,600		
10-15-14	3F, 21A	30/60/10	Layout	0.87	250°F	50	0.2169	1.504	0.2554	0.2534	11,860	5,440	4,280 S = 1,222	④
10-15-2							0.2120	1.505	0.2509	0.2516	11,460	4,850		
10-15-13							0.2165	1.503	0.2517	0.2523	9,900	4,280		
10-15-15							0.2148	1.505	0.2524	0.2521	9,680	4,250		

GP13-0115-182

TABLE 3. (Continued) TENSION STRENGTH TEST DATA

Specimen Number	Specimen and Test Setup Configurations (See Figures)	Percent 0°/45°/90° Plies	Test Variable	Moisture Content (% by Wt)	Test Temp	Fastener Torque (in. lb)	Thickness (in.)	Width (in.)	Hole Dia (in.)	Failing Load (lb)		Strain at Failure (μ in./in.)		Mode of Failure									
										Individual	Average	Individual	Average										
11-16-2	3P, 21H	50/40/10	Fastener Patterns, Steel Substrate	NA	RT	50	0.2074	2.507	0.2565 0.2511	24,700	4,430	4,351 S = 157	④ - ①										
11-16-10							0.1971	2.510	0.2544 0.2513	25,350	4,120												
11-16-11							0.2169	2.503	0.2526 0.2533	24,900	4,390												
11-16-12							0.2181	2.504	0.2517 0.2517	24,900	4,465												
11-16-18							0.2112	2.502	0.2510 0.2516	19,000	3,240												
11-16-1							0.1944	2.500	0.2540 0.2513	19,000	3,480			19,400 S = 1,046	④ - ①								
11-16-13							0.1987	2.510	0.2515 0.2522	20,950	3,570												
11-16-19							0.1946	2.503	0.2514 0.2510	18,650	3,220												
11-16-24							3P, 21I	50/40/10	Fastener Patterns, Titanium Substrate	NA	RT			50	0.2033	2.507	0.2564 0.2516	26,150	4,580	4,345 S = 209	③		
11-16-17															0.2116	2.498	0.2521 0.2544	25,200	4,200				
11-16-5															0.2107	2.507	0.2513 0.2521	24,850	4,140				
11-16-23															0.2033	2.505	0.2527 0.2520	26,250	4,460				
11-16-8															0.2137	0.502	0.2521 0.2507	23,200	4,040				
11-13-20															0.2041	2.506	0.2514 0.2510	21,900	3,980			21,513 S = 1,329	⑥
11-16-6															0.2126	2.505	0.2517 0.2539	20,200	3,620				
11-16-7							0.1946	2.497	0.2535 0.2515	20,750	3,870			2,509 0.2534	④ - ①								

GP125015-247

TABLE 3. (Continued) TENSION STRENGTH TEST DATA

Specimen Number	Specimen and Test Setup Configurations (See Figures)	Percent 0°/45°/90° Plies	Test Variable	Moisture Content (% by Wt)	Test Temp	Fastener Torque (in.-lb)	Thickness (in.)	Width (in.)	Hole Dia (in.)	Failing Load (lb)		Strain at Failure (μm./in.)		Mode of Failure
										Individual	Average	Individual	Average	
11-13-19	3P, 21J	50/40/10		NA	RT	50	0.1944	2.508	0.2527 0.2507 0.2553 0.2521	26,600	4,500	4,500	③	
11-13-13							0.1997	2.502	0.2537 0.2515 0.2506 0.2513	26,250	4,510	4,605	⑤	
11-16-22							0.1918	2.503	0.2524 0.2511 0.2523 0.2528	27,050	4,720	S = 116	⑦	
11-16-15							0.2192	2.504	0.2515 0.2510 0.2530 0.2520	26,500	4,690	⑥		
11-16-14							0.2159	2.500	0.2553 0.2549 0.2522 0.2524	24,750	4,450	⑥		
11-13-15							0.2000	2.502	0.2524 0.2514 0.2552 0.2517	23,550	4,340	4,223	④ ①	
11-16-9							0.2140	2.504	0.2543 0.2512 0.2523 0.2513	22,700	4,180	S = 230		
11-16-3							0.2119	2.508	0.2523 0.2518 0.2510 0.2524	22,700	3,320	④ ①		
11-16-16							0.1970	2.500	0.2530 0.2520 0.2537 0.2536	23,000	4,510	④ ①		
11-16-4							0.1944	2.500	0.2517 0.2510 0.2536 0.2512	23,150	4,385	4,578	④ ①	
11-13-16	0.2123	2.503	0.2523 0.2511 0.2517 0.2510	25,500	5,065	S = 332								
11-16-20	0.2056	2.501	0.2541 0.2510 0.2514 0.2529	22,900	4,350	④ ①								
11-15-19	3P, 21H	30/60/10	NA	RT	50	0.2127	2.505	0.2546 0.2522 0.2500 0.2520	22,800	5,610	5,470	③		
11-15-22						0.2103	2.507	0.2510 0.2519 0.2524 0.2520	22,600	5,530	S = 133			
11-15-23						0.2175	2.500	0.2541 0.2517 0.2532 0.2520	23,550	5,440	③			
11-15-17						0.2205	2.503	0.2511 0.2515 0.2527 0.2518	22,650	5,300	③			

GP13-0115-248

TABLE 3. (Continued) TENSION STRENGTH TEST DATA

Specimen Number	Specimen and Test Setup Configurations (See Figures)	Percent 0°/45°/90° Plies	Test Variable	Moisture Content (% by Wt)	Test Temp	Fastener Torque (in.-lb)	Thickness (in.)	Width (in.)	Hole Dia (in.)	Failing Load (lb)		Strain at Failure (μ in./in.)		Mode of Failure
										Individual	Average	Individual	Average	
11-15-20	3P, 21H	30/60/10	Fastener Patterns, Steel Substrate	0.91	250°F	50	0.2203	2.504	0.2544 0.2520 0.2555 0.2537	19,400	4,825	5,114	④	
11-15-21				0.92			0.2173	2.498	0.2523 0.2517 0.2507 0.2524	20,300	5,400	5,114	④	
11-15-18				0.91			0.2178	2.500	0.2551 0.2525 0.2544 0.2527	21,375	5,150	5,114	④ ③	
11-15-24				0.89			0.2152	2.504	0.2531 0.2526 0.2527 0.2522	21,225	5,080	5,114	④ ⑥	
11-17-3	3O, 21H	50/40/10	Fastener Patterns, Steel Substrate, T300/5208 Material	NA	RT	50	0.2064	2.502	0.2521 0.2520 0.2507 0.2511	21,100	3,315	3,354	④ ①	
11-17-5							0.2094	2.501	0.2542 0.2508 0.2527 0.2571	21,600	3,580	3,354	④ ①	
11-17-2							0.2055	2.510	0.2516 0.2509 0.2530 0.2516	21,050	3,260	3,354	④ ⑥	
11-17-8							0.2070	2.504	0.2568 0.2518 0.2531 0.2543	21,300	3,260	3,354	④ ①	
11-18-3	3O, 21H	30/60/10	Fastener Patterns, Steel Substrate, T300/5208 Material	NA	RT	50	0.2103	2.507	0.2523 0.2517 0.2513 0.2514	20,900	4,620	4,695	③	
11-18-5							0.2077	2.506	0.2526 0.2517 0.2514 0.2517	20,700	4,690	4,695	③	
11-18-2							0.2047	2.512	0.2557 0.2523 0.2520 0.2542	20,450	4,480	4,695	③	
11-18-8							0.1996	2.492	0.2542 0.2516 0.2525 0.2519	22,500	4,990	4,695	③	

Notes:
 Hole diameter dimension legend:

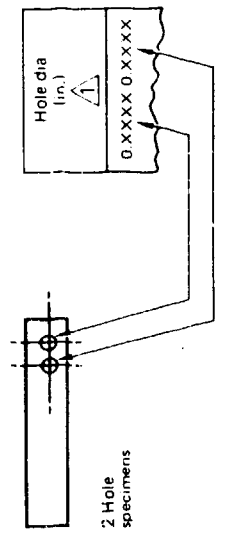
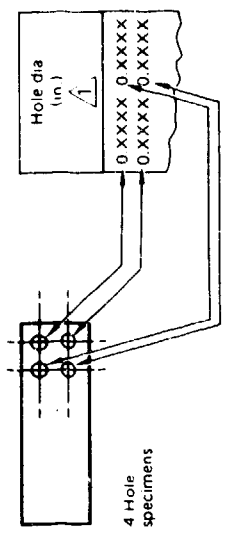
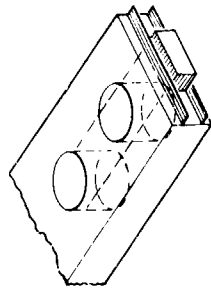
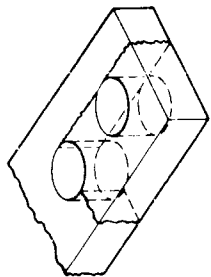
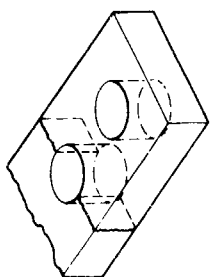
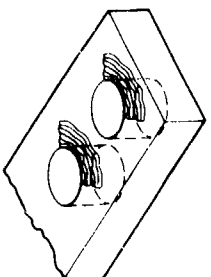
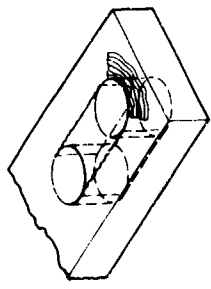
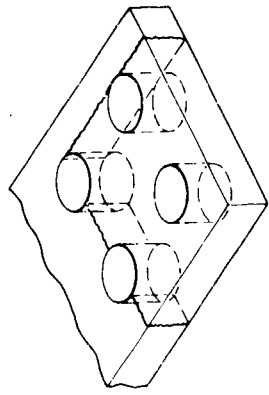
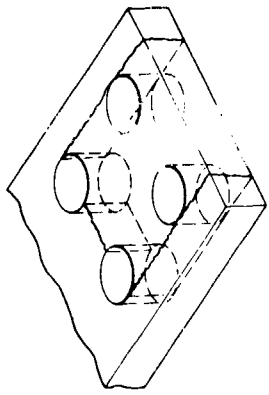
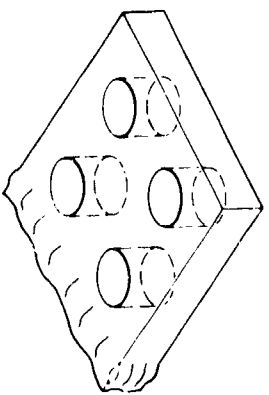

TABLE 3. (Concluded) TENSION STRENGTH TEST DATA

<p>△ 2 e/d = 3 for all specimens except as noted in the test variable column</p> <p>△ 3 w/d = 6 for all specimens except as noted in the test variable column</p> <p>△ 4 20 ply thickness for all specimens except as noted in the test variable column</p> <p>△ 5 4 d hole spacing for all specimens except as noted in the test variable column</p> <p>△ 6 AS/3501-6 graphite/epoxy prepreg material used for all specimens except as noted in the test variable column</p> <p>△ 7 Specimen failed while changing range setting on test machine. Actual failing load could not be determined</p> <p>△ 8 Testing terminated due to lack of high strength 3/16 diameter bolts. Type of bolts used failed in shear</p> <p>△ 9 Specimens were exposed to 5% NaCl salt spray at 95°F for 34 days</p> <p>△ 10 Mode of failure legend: ④ - ① implies a combination bearing-shearout mode of failure</p>	<p>① Shearout mode 0° and 90° plies "pushed" out in front of bolt hole.</p>  <p>② Tension-cleavage mode net section and shearout combination. Failure extends along shearout path and net section path.</p>  <p>③ Net section mode failure only in net section area. Similar for four hole specimens.</p>  <p>④ Bearing mode failure localized directly in front of bolt.</p>  <p>⑤ Shearout between holes-bearing mode.</p>  <p>⑥ Tension cleavage mode four hole specimens.</p>  <p>⑦ Shearout-tension mode.</p>  <p>⑧ Block compression beyond holes mode similar for two hole specimens.</p> 
--	---

GP13-0115-250

TABLE 4. COMPRESSION STRENGTH TEST DATA

Specimen Number	Specimen and Test Setup Configurations (See Figures)	Percent 0°/45°/90° Plies	Test Variable	Moisture Content (% by Wt)	Test Temp	Fastener Torque (in. lb)	Thickness (in.)	Width (in.)	Hole Dia (in.)	Failing Load (lb)		Strain at Failure (μin./in.)		Mode of Failure								
										Individual	Average	Individual	Average									
3-1-19	3F, 21G	50/40/10	Single Shear	NA	RT	50	0.2225	1.508	0.2518	0.2516	11,350	3,280		④								
3-1-14							0.1996	1.502	0.2531	0.2511	11,500	3,455	11,950		3,455							
3-10-11							0.1976	1.502	0.2507	0.2513	12,150	3,375	S = 655		S = 184							
3-12-35							0.2105	1.506	0.2513	0.2523	12,800	3,710										
3-11-2							0.1953	1.505	0.2511	0.2514	11,500	3,205										
3-10-4							0.1973	1.504	0.2521	0.2531	10,600	3,135	11,650		3,259							
3-11-6							0.1966	1.501	0.2528	0.2522	12,700	3,505	S = 866		S = 167							
3-1-5							0.2122	1.508	0.2513	0.2544	11,800	3,190										
3-12-11							0.2216	1.502	0.2507	0.2513	11,760	3,230										
3-1-9							0.2138	1.517	0.2528	0.2503	10,500	2,835	10,715		2,923							
3-12-32							0.2124	1.506	0.2560	0.2508	10,200	2,805	S = 708		S = 205							
3-12-29							0.2136	1.504	0.2538	0.2596	10,400	2,820										
10-10-10							3F, 21A	50/40/10	Layup	NA	RT	50	0.2025		1.500	0.2514	0.2504	14,100	4,660		④	
10-12-24													0.2173		1.503	0.2506	0.2552	13,800	4,445	14,165		4,791
10-10-15													0.1888		1.503	0.2513	0.2517	14,680	4,780	S = 370		S = 354
10-12-19	0.2096	1.503	0.2520	0.2525	14,080	5,280																
10-10-25	0.2162	1.502	0.2560	0.2567	14,000	4,440																
10-12-6	0.2069	1.505	0.2489	0.2490	14,900	4,640							14,810	4,741								
10-1-6	0.2299	1.567	0.2532	0.2517	16,140	5,025							S = 946	S = 255								
10-10-14	0.2077	1.502	0.2496	0.2510	14,300	4,860																
10-10-12	0.2060	1.502	0.2516	0.2520	11,080	3,760																
10-12-14	0.2216	1.506	0.2525	0.2512	11,200	3,500							11,405	3,790								
10-10-27	0.2130	1.499	0.2498	0.2512	11,720	4,332							S = 313	S = 378								
10-12-26	0.2089	1.506	0.2504	0.2500	11,620	3,568																
10-14-7	0.1851	1.500	0.2532	0.2531	11,440	3,090																
10-14-10	0.1850	1.499	0.2524	0.2502	10,950	2,600							11,493	2,875								
10-14-11	0.1888	1.503	0.2566	0.2560	11,880	2,810							S = 404	S = 217								
10-14-4	0.1901	1.499	0.2497	0.2516	11,700	3,000																
10-14-8	0.1889	1.501	0.2536	0.2536	7,580	2,240																
10-14-9	0.1918	1.505	0.2511	0.2524	7,960	2,185	7,715	2,136														
10-14-6	0.1908	1.497	0.2536	0.2517	7,300	2,104	S = 213	S = 98														
10-14-12	0.1905	1.501	0.2530	0.2502	7,820	2,016																

GP130115-103

TABLE 4. (Continued) COMPRESSION STRENGTH TEST DATA

Specimen Number	Specimen and Test Setup Configurations (See Figures)	Percent 0°/45°/90° Plies	Test Variable	Moisture Content (% by Wt)	Test Temp	Fastener Torque (in.-lb)	Thickness (in.)	Width (in.)	Hole Dia (in.)	Failing Load (lb)		Strain at Failure (μin./in.)		Mode of Failure
										Individual	Average	Individual	Average	
10-15-7	3F, 2:1A	30/60/10	Layout	NA	RT	50	0.2154	1.505	0.2521	0.2517	13,410	5,950	6,055	⑧
10-15-10							0.2151	1.504	0.2511	0.2502	12,800	5,520	6,055	④
10-15-11							0.2183	1.504	0.2500	0.2525	13,380	6,375	S = 408	
10-15-4							0.2127	1.503	0.2501	0.2505	13,000	5,375		
10-15-8							0.2183	1.504	0.2544	0.2530	11,000	4,185		⑧
10-15-9							0.2146	1.501	0.2515	0.2500	10,700	4,995	10,285	5,085
10-15-6							0.2146	1.505	0.2532	0.2534	10,000	5,500	S = 702	S = 301
10-15-12							0.2147	1.506	0.2535	0.2503	9,440	5,060		
11-13-17	3P, 2:1J	50/40/10	Fastener Patterns, Aluminum Substrate			0	0.1989	2.506	0.2545	0.2512	17,200	3,305	④	
11-16-21							0.2072	2.503	0.2515	0.2514	17,300	3,400	⑦	⑦
11-13-14	3P, 2:1H	50/40/10	Fastener Patterns, Steel Substrate			70	0.2127	2.507	0.2522	0.2518	22,550	3,225	④	
11-13-18							0.2094	2.509	0.2525	0.2512	33,250	⑧	④	
11-15-26	3P, 2:1J	30/60/10	Fastener Patterns, Aluminum Substrate	NA	RT	0	0.2118	2.503	0.2508	0.2503	21,360	5,685	④	
11-15-16							0.2138	2.503	0.2535	0.2583	23,000	6,025	⑦	④
11-15-25							0.2054	2.509	0.2557	0.2512	29,300	⑧	⑧	
11-15-27							0.2087	2.506	0.2545	0.2543	29,350	⑧	⑧	
11-17-1	3D, 2:1J	50/40/10	Fastener Patterns, Aluminum Substrate, T300/5208 Material			0	0.2037	2.502	0.2522	0.2512	15,800	2,820	④	
11-17-7							0.2048	2.499	0.2515	0.2547	23,150	4,160	⑦	④
11-17-6							0.2091	2.505	0.2548	0.2514	31,400	⑧	⑧	
11-17-4							0.2083	2.502	0.2525	0.2520	28,700	4,320	⑦	⑧

GP13-0115-104

TABLE 4. (Continued) COMPRESSION STRENGTH TEST DATA

Specimen Number	Specimen and Test Setup Configurations (See Figures)	Percent 0°/45°/90° Plies	Test Variable	Moisture Content (% by Wt)	Test Temp	Fastener Torque (in.-lb)	Thickness (in.)	Width (in.)	Hole Dia (in.)	Failing Load (lb)		Strain at Failure (μ in./in.)		Mode of Failure	
										Individual	Average	Individual	Average		
11-18-1	30, 21J	30/60/10	Fastener Patterns, Aluminum Substrate, T300/5208 Material	NA	RT	0	0.2052	2.506	0.2523 0.2515 0.2505 0.2517	7	16,050	3,720	7	4	
11-18-7							0.2068	2.503	0.2530 0.2516 0.2505 0.2530		16,450	4,125			
11-18-6							0.2038	2.512	0.2524 0.2517 0.2510 0.2500		28,200	8			8
11-18-4							0.2054	2.511	0.2516 0.2518 0.2515 0.2524		23,450	8			8

Notes:

△, Hole diameter dimension legend:

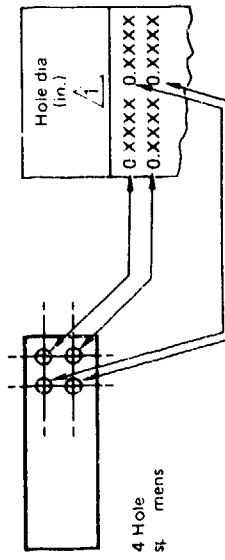

4 Hole specimens

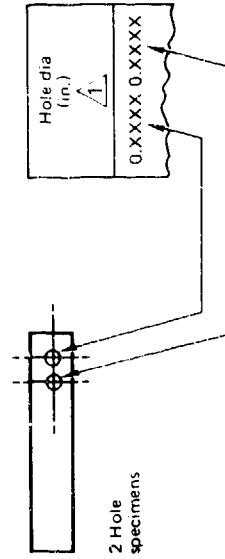

2 Hole specimens

TABLE 4. (Concluded) COMPRESSION STRENGTH TEST DATA

<p>△ 2 e/d = 3 for all specimens except as noted in the test variable column</p> <p>△ 3 w/d = 6 for all specimens except as noted in the test variable column</p> <p>△ 4 20 ply thickness for all specimens except as noted in the test variable column</p> <p>△ 5 4 d hole spacing for all specimens except as noted in the test variable column</p> <p>△ 6 AS/3501-6 graphite/epoxy prepreg material used for all specimens except as noted in the test variable column</p> <p>△ 7 Specimen failed while changing range setting on test machine. Actual failing load could not be determined</p> <p>△ 8 Testing terminated due to lack of high strength 3/16 diameter bolts. Type of bolts used failed in shear</p> <p>△ 9 Specimens were exposed to 5% NaCl salt spray at 95°F for 34 days</p> <p>△ 10 Mode of failure legend: ④ - ① implies a combination bearing-shearout mode of failure</p>	<p>① Shearout mode 0° and 90° plies "pushed" out in front of bolt hole.</p> <p>② Tension-cleavage mode net section and shearout combination. Failure extends along shearout path and net section path.</p> <p>③ Net section mode failure only in net section area. Similar for four hole specimens.</p> <p>④ Bearing mode failure localized directly in front of bolt.</p> <p>⑤ Shearout between holes-bearing mode.</p> <p>⑥ Tension cleavage mode four hole specimen.</p> <p>⑦ Shearout-tension mode.</p> <p>⑧ Block compression beyond holes mode similar for two hole specimens.</p>
--	--

GP13-0115-250

TABLE 5. LOAD INTERACTION STRENGTH TEST DATA

Specimen Number	Specimen and Test Setup Configurations (See Figures)	Test Variable	Fastener Torque (in.-lb)	Width (in.)	Thickness (in.)		Hole Dia (in.)		Load On Bolts (lb)	Failing Load (lb)		Strain at Failure (μ in./in.)				Mode of Failure	
					At Hole 1	At Hole 2	Hole 1	Hole 2		Individual	Average	Individual	Average	Gage 1	Gage 2		Individual
12-19-11	3R, 8	Load Interaction 100 Off-Axis Tension Loading	0	2.003	0.2083	0.2085	0.2497	0.2498	1,300	23,000	5,220	5,413	5,070	①			
12-19-12				2.005	0.2034	0.1976	0.2499	0.2506		25,000	5,725	5,413	5,450		5,134		
12-19-7				2.004	0.2161	0.2124	0.2500	0.2498		22,700	5,245	S = 235	4,920		S = 225		
12-19-15		1.999	0.2015	0.1984	0.2500	0.2499	23,800	5,460	④	5,095	④	④					
12-19-29		2.000	0.2126	0.2133	0.2505	0.2499	19,100	4,625		4,265							
12-19-14		2.004	0.1963	0.1913	0.2500	0.2497	21,000	3,700		7,200							
12-19-13	3S, 8	Load Interaction 100 Off-Axis Comp Loading	③	1.998	0.2052	0.2052	0.2499	0.2498	③	③	③	③	③	①			
12-19-10				2.004	0.2095	0.2043	0.2500	0.2498							31,200	5,565	5,370
12-19-34				2.505	0.2164	0.2144	0.2499	0.2502							29,900	5,405	5,399
12-19-1		2.505	0.2073	0.2077	0.2497	0.2498	1,430	29,200	S = 847	5,290	S = 121	5,015	S = 196				
12-19-2		2.506	0.2080	0.2124	0.2498	0.2499	29,750	5,335	4,920	①							
12-19-9		2.505	0.2116	0.2121	0.2499	0.2499	44,900	6,140	5,520								
12-19-3	3.501	0.2121	0.2128	0.2498	0.2499	41,800	5,540	5,175									
12-19-4	3.505	0.2155	0.2176	0.2499	0.2500	42,400	5,750	5,045	4,785								
12-19-5	3.504	0.2166	0.2120	0.2499	0.2498	39,900	5,335	5,335	5,335	5,335							
12-19-6	3.503	0.2180	0.2183	0.2500	0.2499												

Notes

① Specimen dimensional legend

④ Average data was not calculated for two data points.

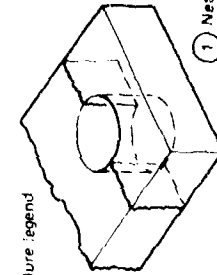
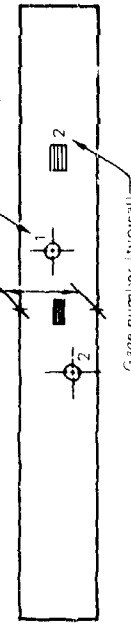

② All specimens were 20 plies thick and were fabricated using AS/3501-6 graphite-epoxy prepreg material. Percentage 0°/45°/90° plies was 50/40/10

③ Testing terminated because of instability of specimen under compression loading.

GH194115-166

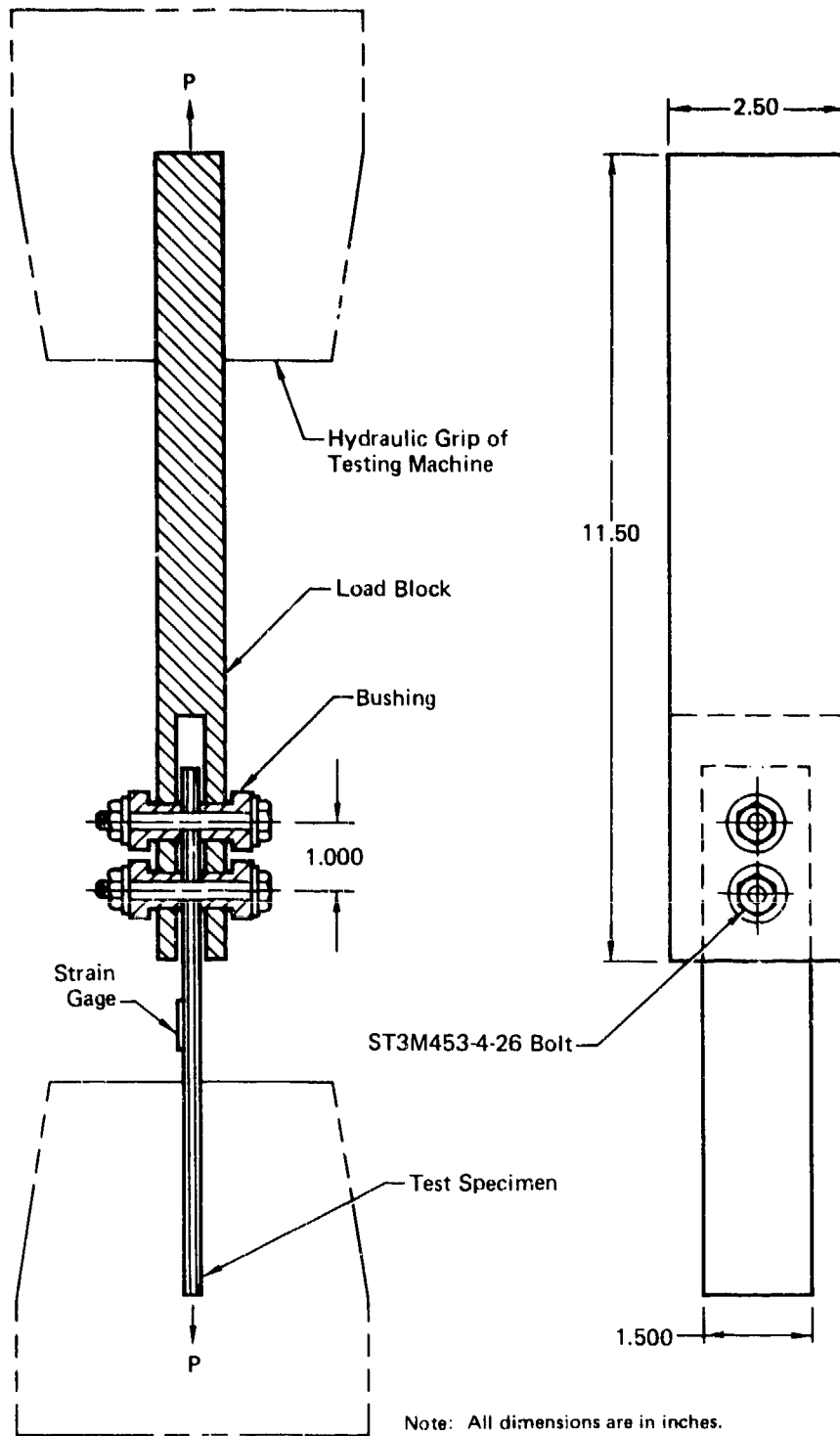

Test Configuration 21A

GP13-0115-166

Figure 21. Multiple Fastener Test Setups

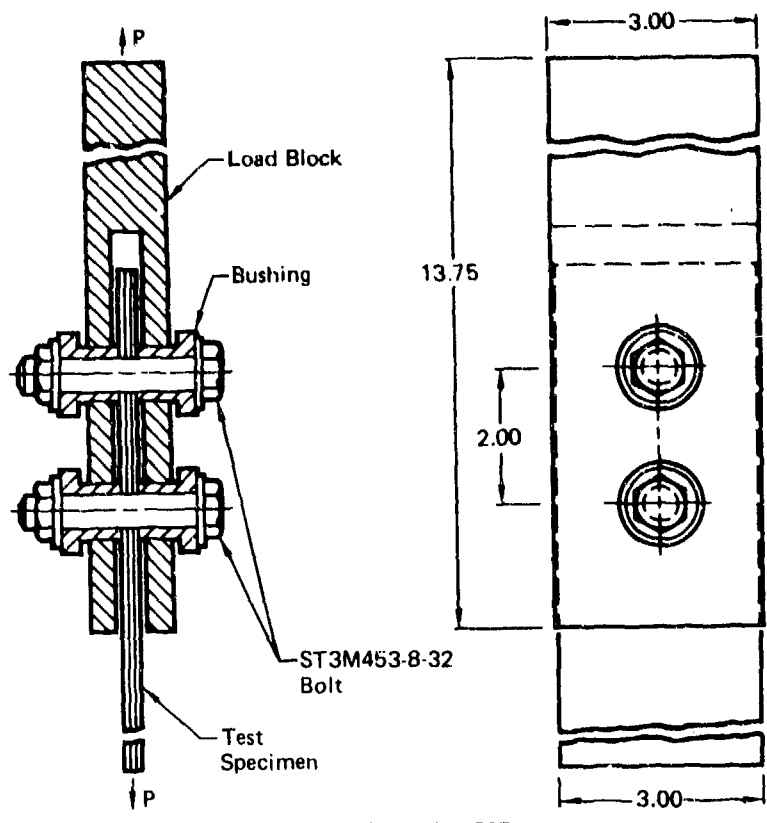

Test Configuration 21B

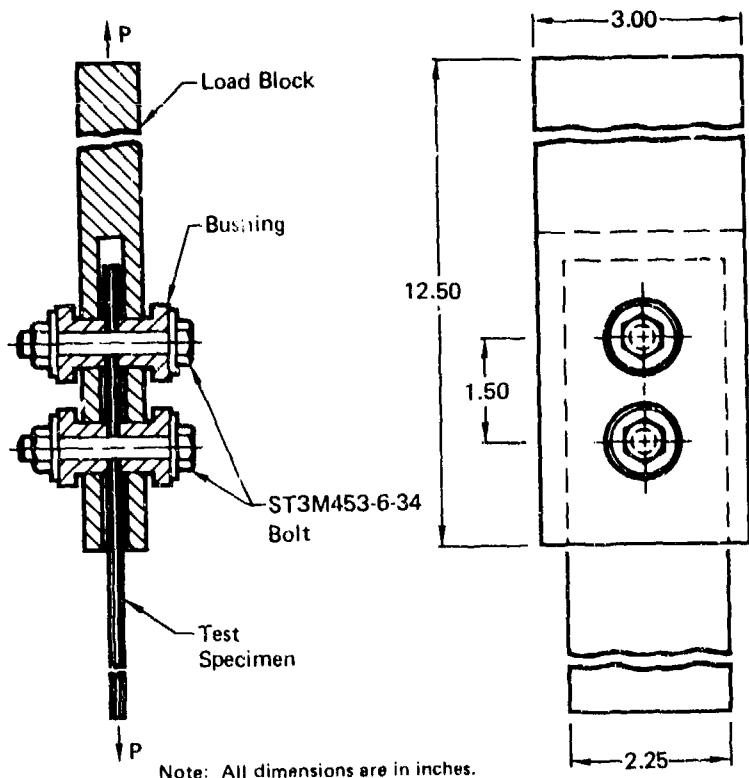

Note: All dimensions are in inches.

Test Configuration 21C

GP13-J116-167

Figure 21 (Continued) Multiple Fastener Test Setups

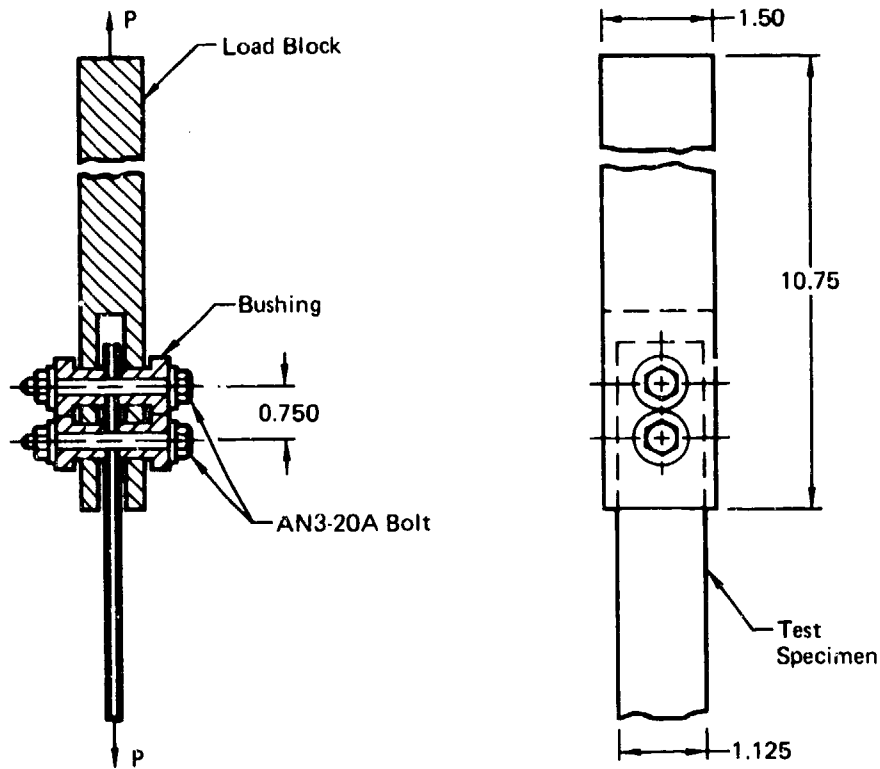

Test Configuration 21D

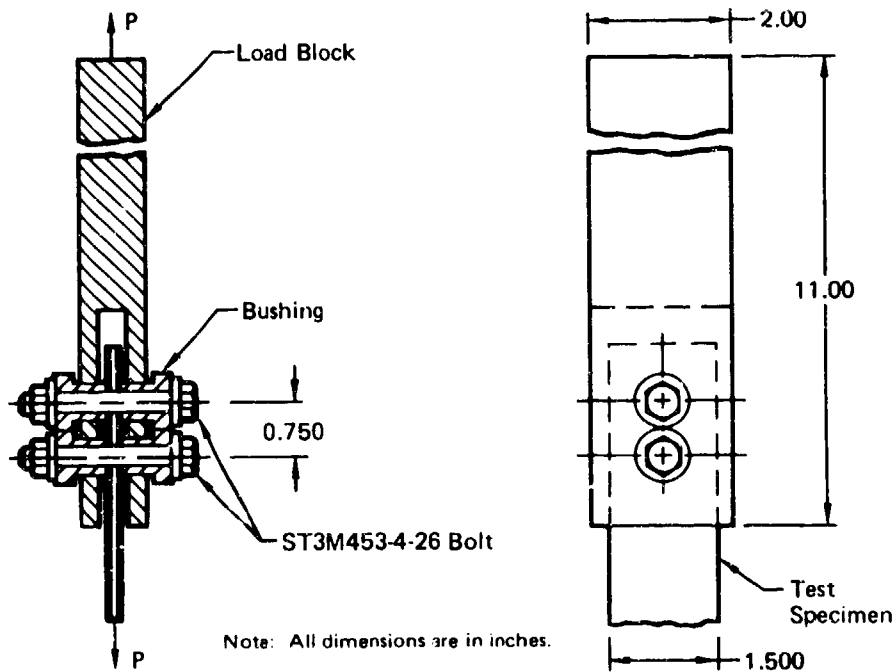

Test Configuration 21E

GP13-0116-231

Figure 21 (Continued) Multiple Fastener Test Setups

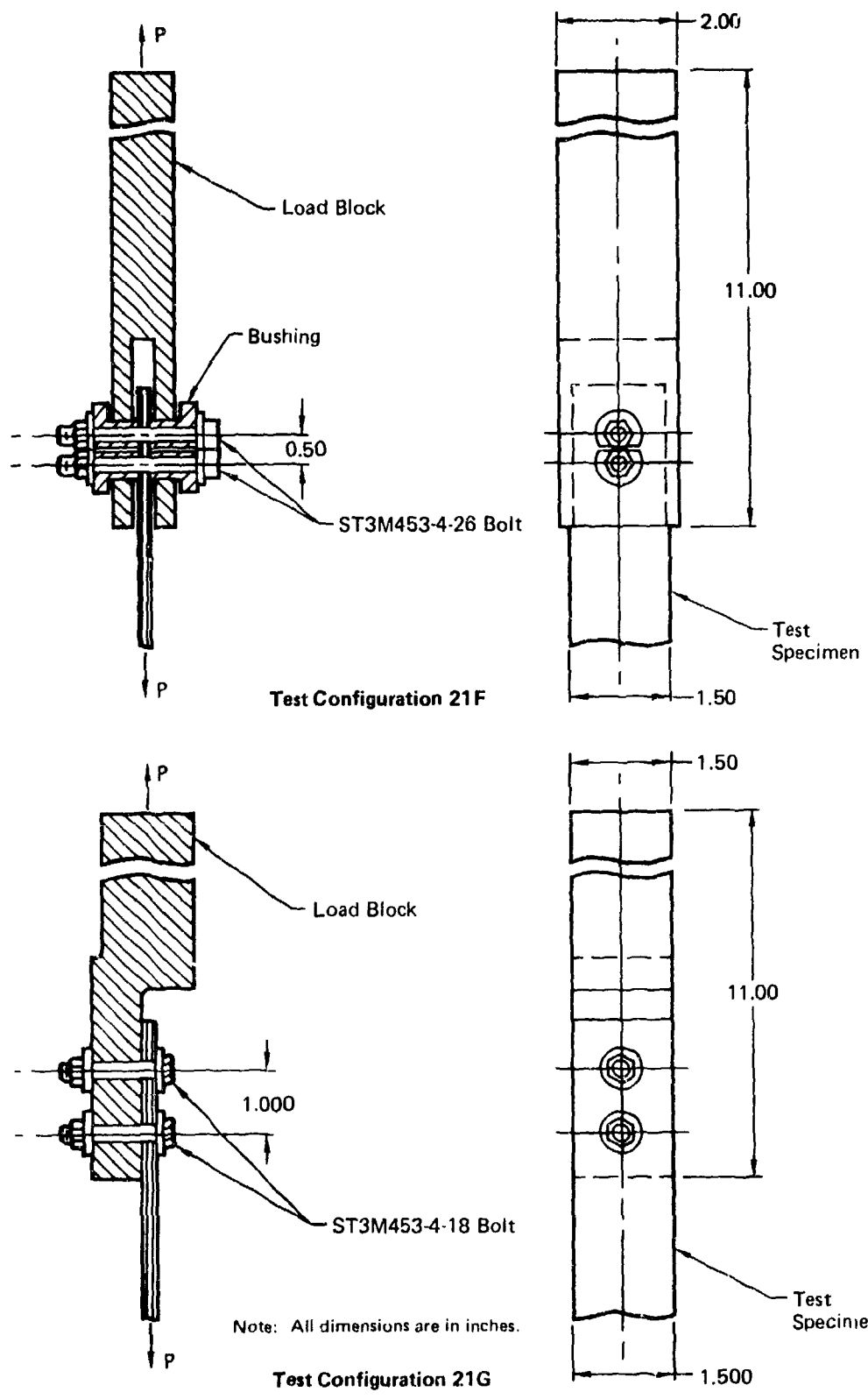
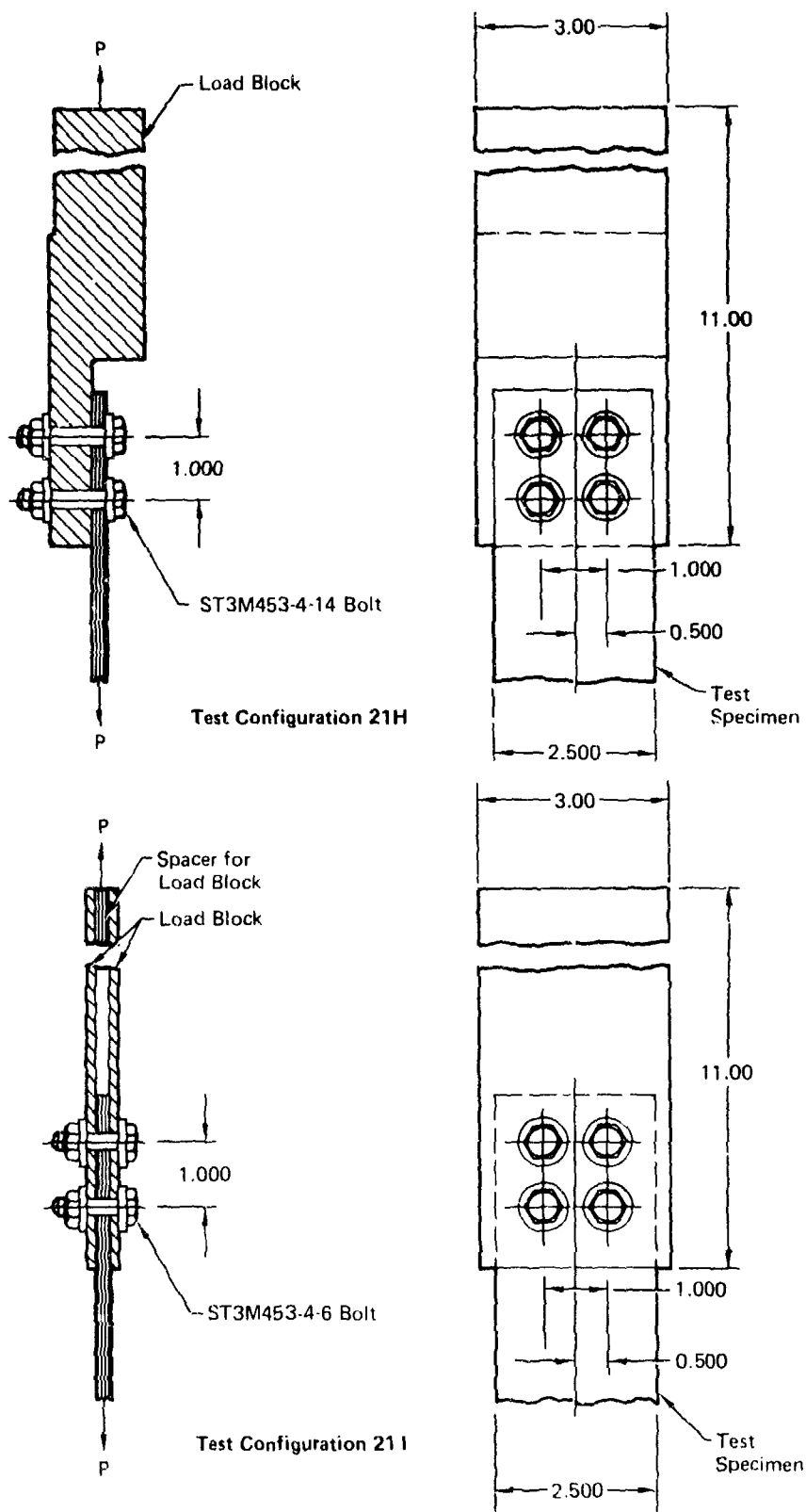

Figure 21. (Continued) Multiple Fastener Test Setups

GP13-0115-188



QP13-0115-230

Figure 21. (Continued) Multiple Fastener Test Setups

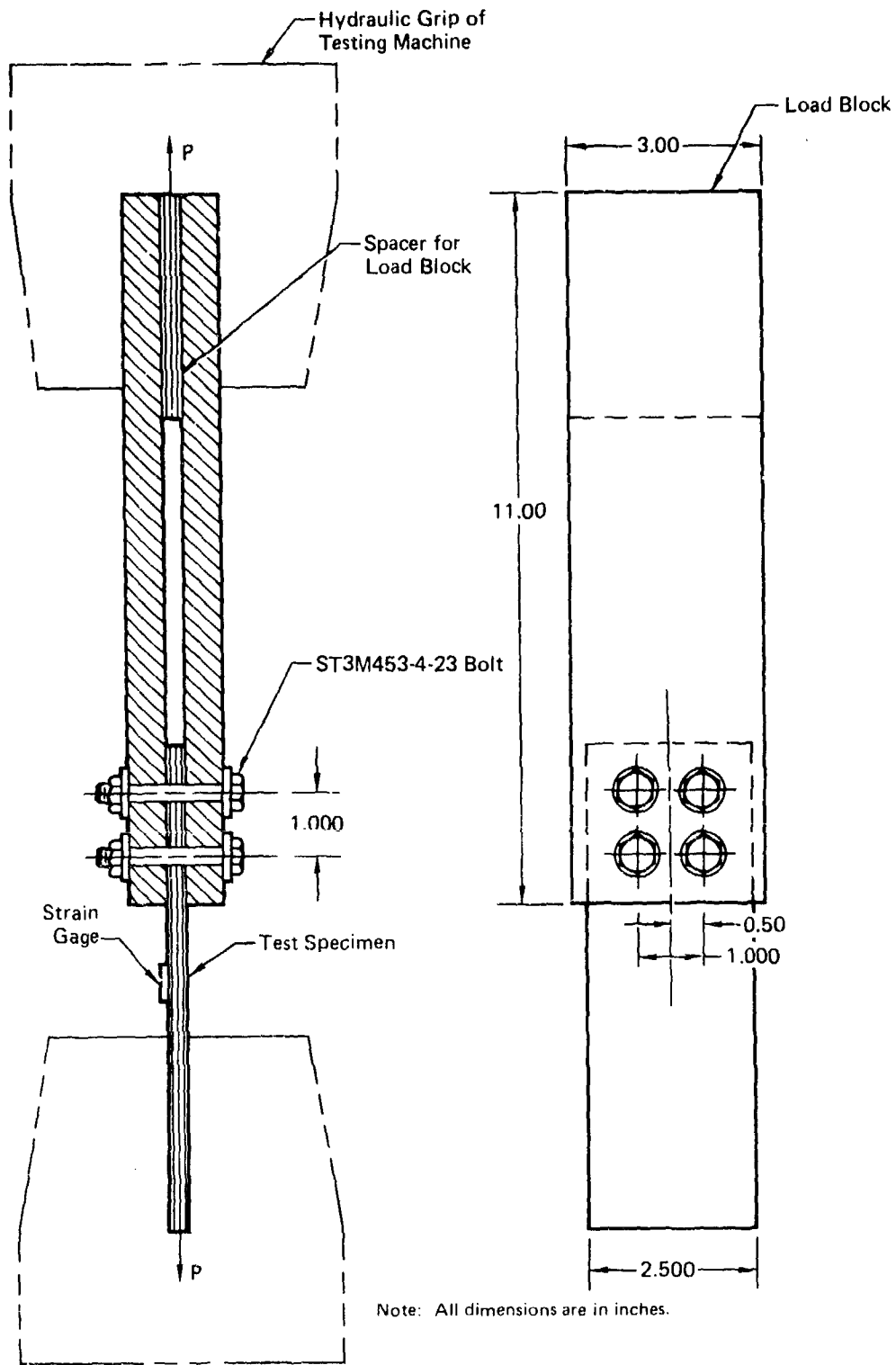

Test Configuration 21J

GP13-0115-169

Figure 21. (Concluded) Multiple Fastener Test Setups

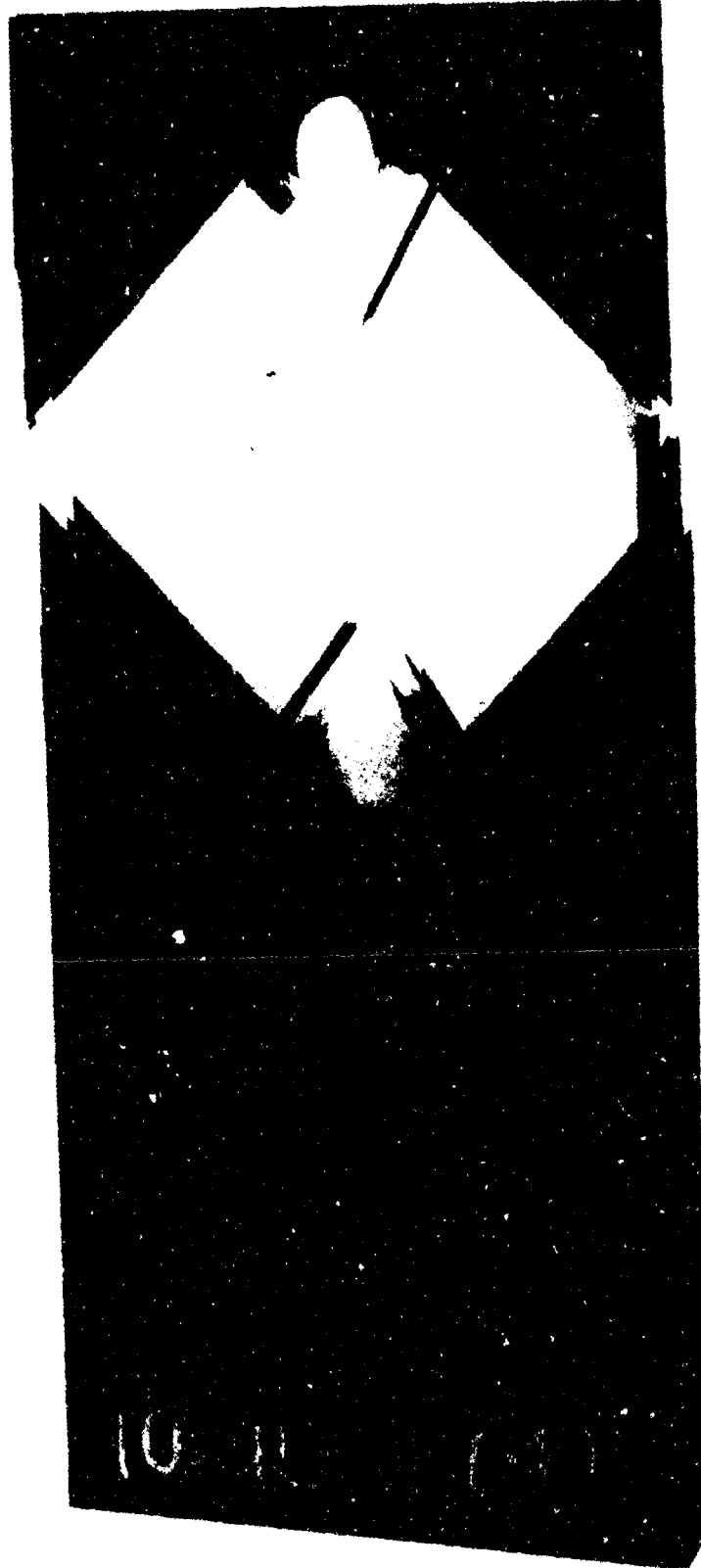

GP13-0115-170

Figure 22. Net Section Mode of Failure

Specimen Number 1-1-8



Plan View of Failure

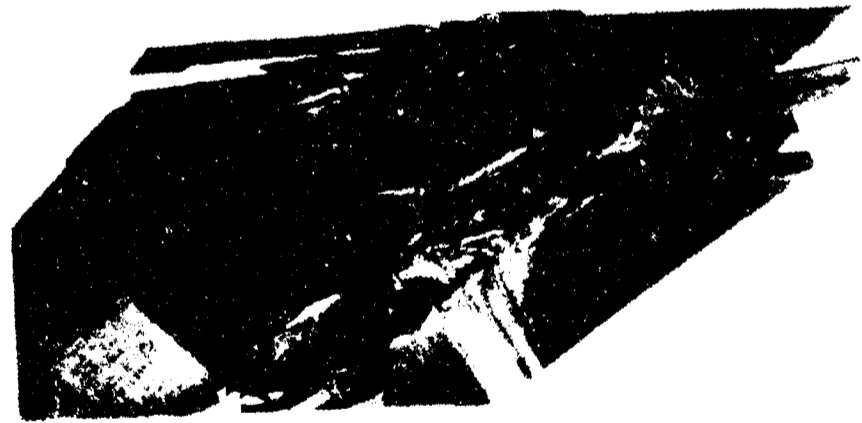

Edge View of Failure

GP13-0115-171

Figure 23. Bearing-Shearout Mode of Failure

Specimen Number 3-23-5

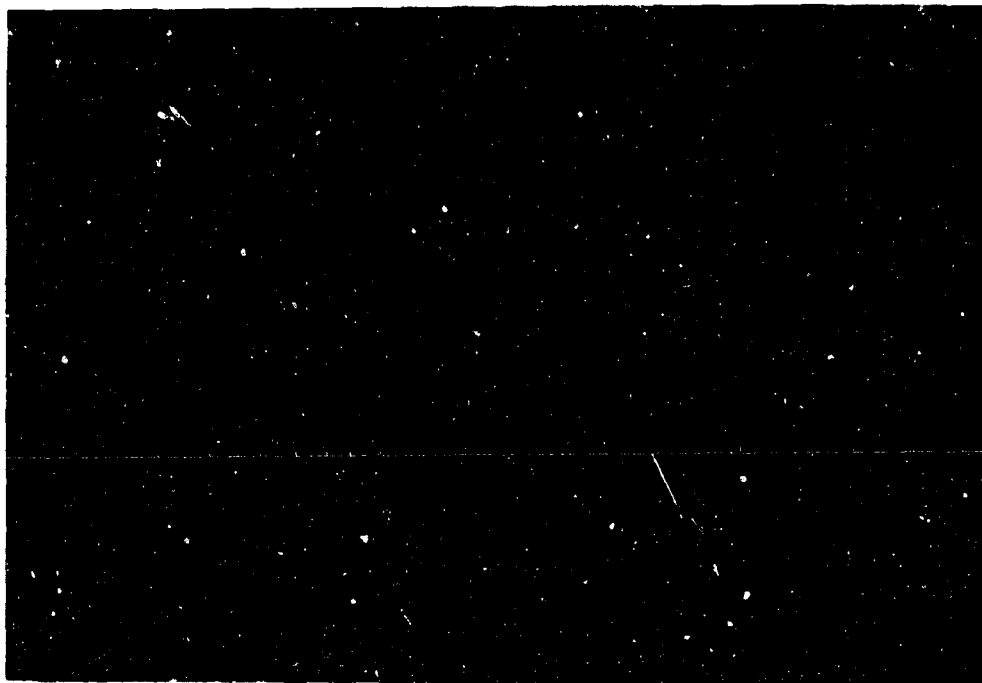

GP13-0115-172

Figure 24. Bearing (Compression Test) Mode of Failure

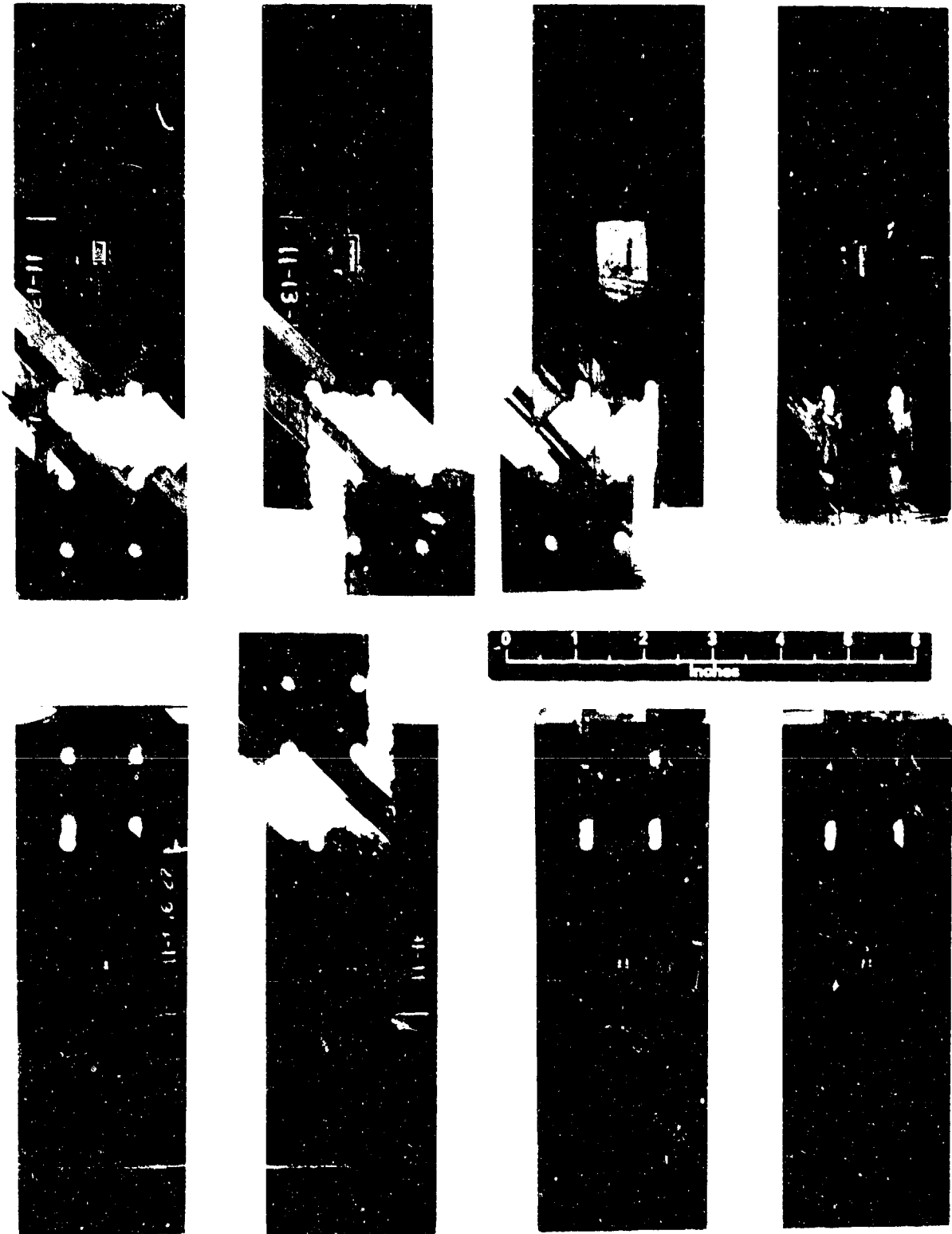

QP13-0115 173

Figure 25. Fastener Pattern Tension Test Specimens After Testing

Specimen Number 11-13-13



GP13-0115-174

Figure 26. Tension-Cleavage Mode of Failure

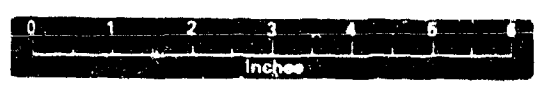
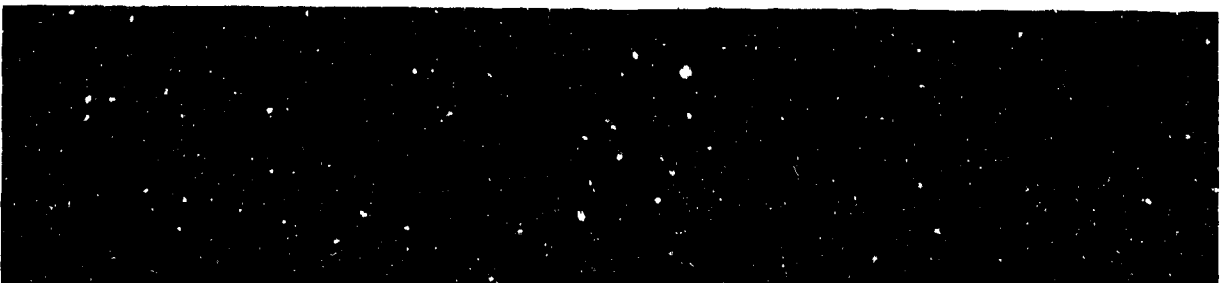
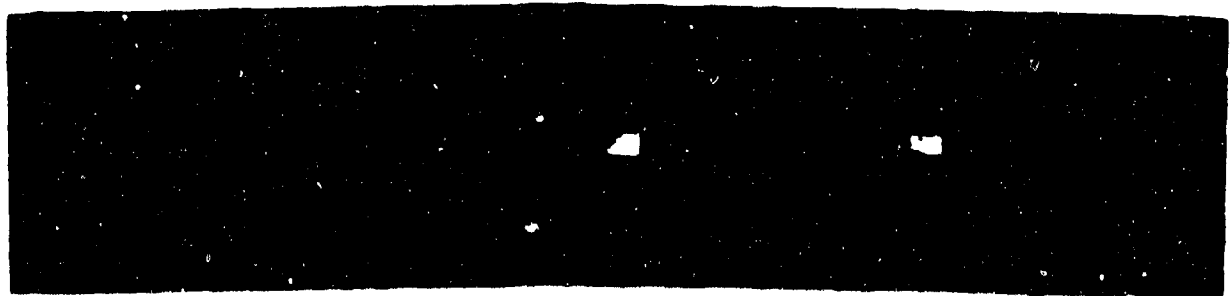

GP13-0115-175

**Figure 27. Load Interaction Tension Net Section Failures
45° Off Axis Test**

SECTION III

RESULTS OF TASK 3 TESTING - MANUFACTURING AND SERVICE ANOMALIES

1. TEST MATRIX AND TEST OBJECTIVES - The objective of Task 3 was to evaluate the effects of commonly occurring manufacturing and service anomalies on the static strength of bolted composite joints. Information obtained from the literature survey of Task 1 was used in conjunction with recent manufacturing experience to identify realistic test variables. Seven anomalies were selected for experimental evaluation. The Task 3 test matrix, shown in Figure 28, details selected test variables and test parameters.

To obtain comparable results to baseline strengths of joints not possessing anomalies from Task 2, the Task 2 baseline test specimen configuration was used to evaluate the effect of each anomaly on static strength. Three environmental conditions were selectively evaluated; room temperature dry (RTD), room temperature wet (RTW) and elevated temperature wet (ETW). These test conditions were the same as those evaluated in Task 2. A replication of four tests per anomaly and environment were performed, for a total of 116 tests in Task 3.

2. SPECIMEN CONFIGURATIONS - Only one test specimen configuration was needed to complete the Task 3 experimental evaluation; a two bolt in-tandem load sharing specimen. This configuration was incorporated in two types of specimens; a single data point specimen and a multiple data point specimen. Illustrated in Figure 29 are the detailed specimen geometries required for Task 3. A total of 14 multi-test and 60 single test specimens were fabricated to complete the evaluation of manufacturing and service anomalies.

3. SPECIMEN QUALITY ASSURANCE - Hercules AS/3501-6 graphite-epoxy was the sole material system used in Task 3. All material was qualified prior to panel fabrication as described in Section II.3.

Autoclave cure cycles were accepted based on process control panels accompanying each panel. Interlaminar shear specimens machined and tested from these panels verified acceptability of each cure cycle run.

To obtain the desired anomalies in the composite specimens, standard quality assurance of fastener hole fabrication or panel fabrication was waived. The anomalies were, however, quantified using ultrasonic C-scan techniques.

Anomaly	Number of Tests Per Environment			Total Specimen Tests
	RT (Dry) Tension	RT (Wet) Compression	ET (Wet) Compression	
1. Out-of-Round Holes "1" Laminate (50/40/10) "2" Laminate (30/60/10)	4 4	— —	— —	4 4
2. Broken Fibers on Exit Side of Hole Severe Delamination Moderate Delamination	4 4	4 4	4 4	12 12
3. Porosity around hole Severe Porosity Moderate Porosity	4 —	2,2 $\triangle 1$ 2,2 $\triangle 1$	4 4	12 8
4. Improper Fastener Seating Depth 80% of Thickness 100% of Thickness	4 4	— —	— —	4 4
5. Tilted Countersinks Away from Bearing Surface Toward Bearing Surface	4 4	— —	4 4	8 8
6. Interference Fit Tolerances 0.003 in. Interference 0.008 in. Interference	Layup 1 1 2 2	4 4 4 4	4 $\triangle 2$ 4 4 4	8 8 8 8
7. Fastener Removal and Reinstallation 100 Cycles	4	—	4	8
Total				116

GP13-0115-110

$\triangle 1$ After freeze-thaw cycling $\triangle 2$ Tension tests

Figure 28. Task 3 - Evaluation of Manufacturing Anomalies-Test Matrix

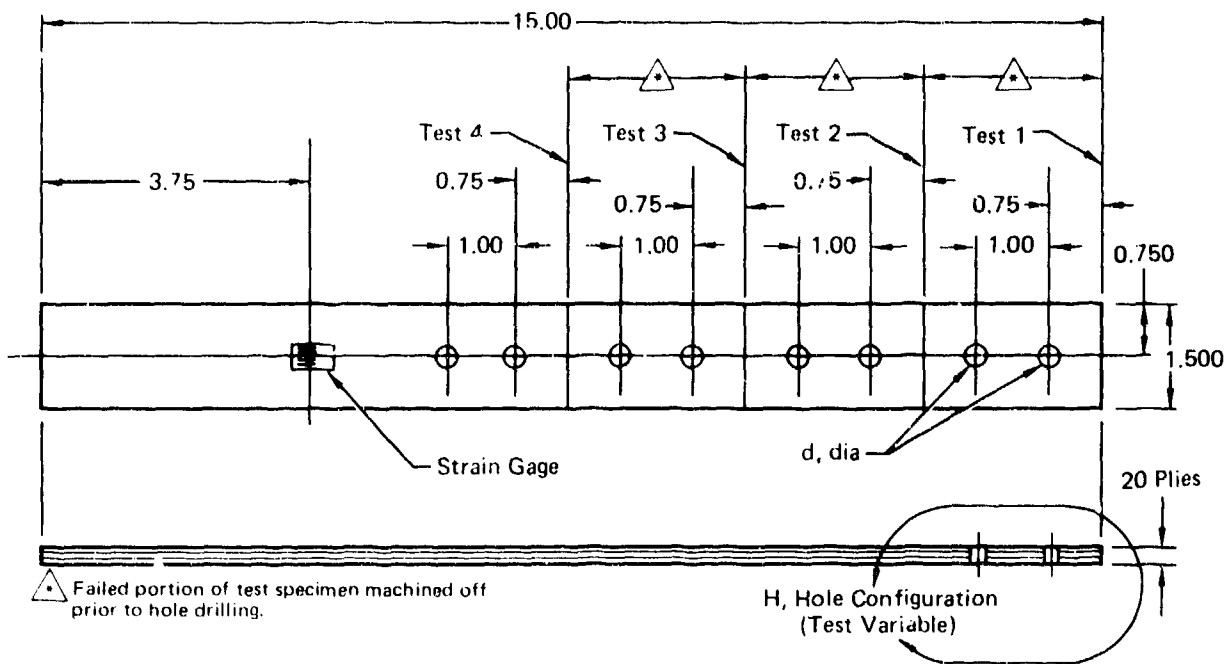

Specimen Configuration	d, dia $\begin{matrix} +0.0022 \\ -0.0000 \end{matrix}$ (in.)	H, Hole Configuration (Test Variable)
29A	0.2495	Out-of-Round
29B	0.2495	Broken Fibers - Moderate Delamination
29C	0.2495	Broken Fibers - Severe Delamination
29D	0.2495	Countersink Seating Depth - 80% of Thickness
29E	0.2495	Countersink Seating Depth - 100% of Thickness
29F	0.2495	Tilted Countersink Away from Bearing Surface
29G	0.2495	Tilted Countersink Toward Bearing Surface
29H	0.2465	Interference Fit
29I	0.2415	Interference Fit
29J	0.2495	Fastener Installation and Removal - Protruding Head
29K	0.2495	Fastener Installation and Removal - Countersunk Head

Multitest Test Specimens

Figure 29. Task 3 Test Specimens

GP13-0115-176

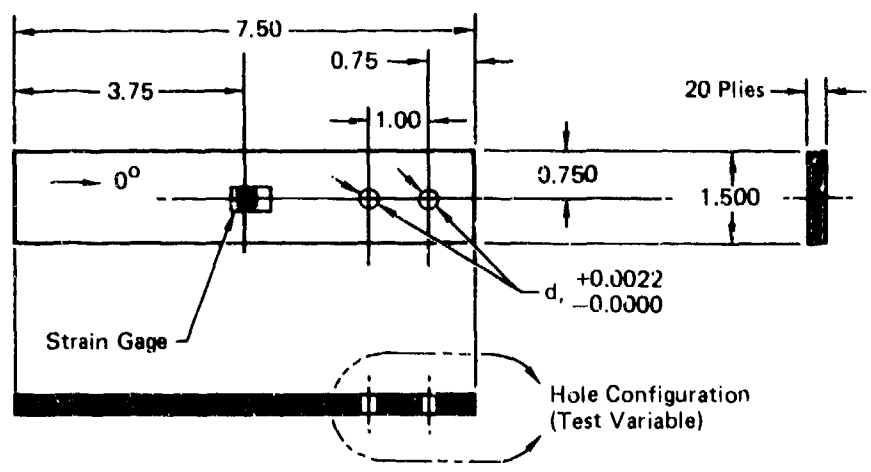

Note: All dimensions are in inches.

Specimen Configuration	d (in.)	Hole Configuration (Test Variable)
29L	0.2495	Severe Porosity
29M	0.2465	Interference Fit
29N	0.2415	Interference Fit
29P	0.2495	Broken Fibers - Moderate Delamination
29Q	0.2495	Broken Fibers - Severe Delamination
29R	0.2495	Moderate Porosity
29S	0.2495	Tilted Countersink Away from Bearing Surface
29T	0.2495	Tilted Countersink Toward Bearing Surface
29U	0.2495	Fastener Installation and Removal - Countersunk Head

Single Test Test Specimens

Figure 29. (Continued) Task 3 Test Specimens

GP13-0115-177

4. PANEL FABRICATION - Four panels were fabricated using AS/3501-6 graphite-epoxy for Task 3. Layup variations used were the baseline 50/40/10 and the 30/60/10 laminate of Task 2. Panel dimensions, ply orientations and stacking sequences are listed in Figure 30.

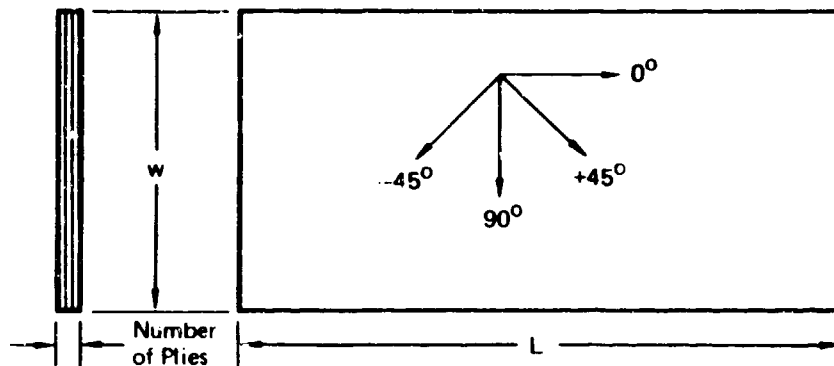

Panel No.	Dimensions (in.)		N of Plies	Stacking Sequence (See Note)	Graphite/Epoxy Prepreg Material Used	
	L	w			Lot No.	Spool No.
20	48	24	20	△1	1,034	3
21	32	12		△2		
△4 22				△1		
△5 23				△1		

GP13-0115-178

Notes

- △1 [+45°, 0°, -45°, 0°, 90°, 0°, +45°, 0°, -45°, 0°]_S
- △2 [+45°, 0°, -45°, 0°, +45°, 90°, -45°, 0°, +45°, -45°]_S
- △3 Hercules AS/3501-6 Graphite/Epoxy prepreg material was used in the fabrication of all panels.
- △4 Panel was fabricated so as to contain severe porosity
- △5 Panel was fabricated so as to contain moderate porosity

Figure 30. Panel Configurations

Two of the four panels were fabricated according to MCAIR process specifications, while two panels were intentionally fabricated to contain various amounts of porosity. Moderate and severe porosity levels were induced using water mist and modified laminate cure cycle procedures. All panels were accepted for testing in Task 3.

5. SPECIMEN FABRICATION - Specimens were fabricated from panels per MCAIR procedures. Unique specimen numbers were used to identify test variable and panel numbers. The specimen identification code used was the same as in Task 2 (Section II.5) with the variable number found in the Task 3 test matrix (Figure 28). Random selection of specimens from within two panels was used prior to hole drilling. Specimens from porous panels were selected by locating areas of desired amounts of porosity using ultrasonic C-scan and orientating specimen dimensions to include the porosity in bolt hole areas.

All manufacturing hole drilling anomalies required fabrication procedures not in compliance with acceptable MCAIR standards. A detailed description of the techniques used for each anomaly is given in the "Special Procedures" section (Section III.8).

A total of 78 specimens were fabricated for Task 3. Reserve panel material was allocated in all panels to permit specimen duplication and material for photomicrographic examination. Thickness, width and hole diameter measurements were recorded for each specimen.

6. TEST PROCEDURES - All specimens were tested to static failure under tensile or compressive loadings as indicated in the Task 3 test matrix (Figure 28). Data documented for all test specimens included:

- o Thickness, width and hole size measurements
- o Failure load and failure strains
- o Load vs strain plots to failure
- o Load vs deflection plots to failure
- o Weight gain of humidity exposure specimens
- o Representative photographs

The double shear load block with 1/4 inch diameter bolts torqued to 50 in-lb used in Task 2 was also used in Task 3. Load, strain and deflection measurements were recorded in the same manner as the baseline Task 2 configuration.

Specimens requiring moisture preconditioning were exposed to the same environmental sequence as the baseline specimens of Task 2. However, due to the nature of the various anomalies, moisture absorption and desorption rates were affected while final equilibrium levels remained fairly constant, as shown in Figure 31.

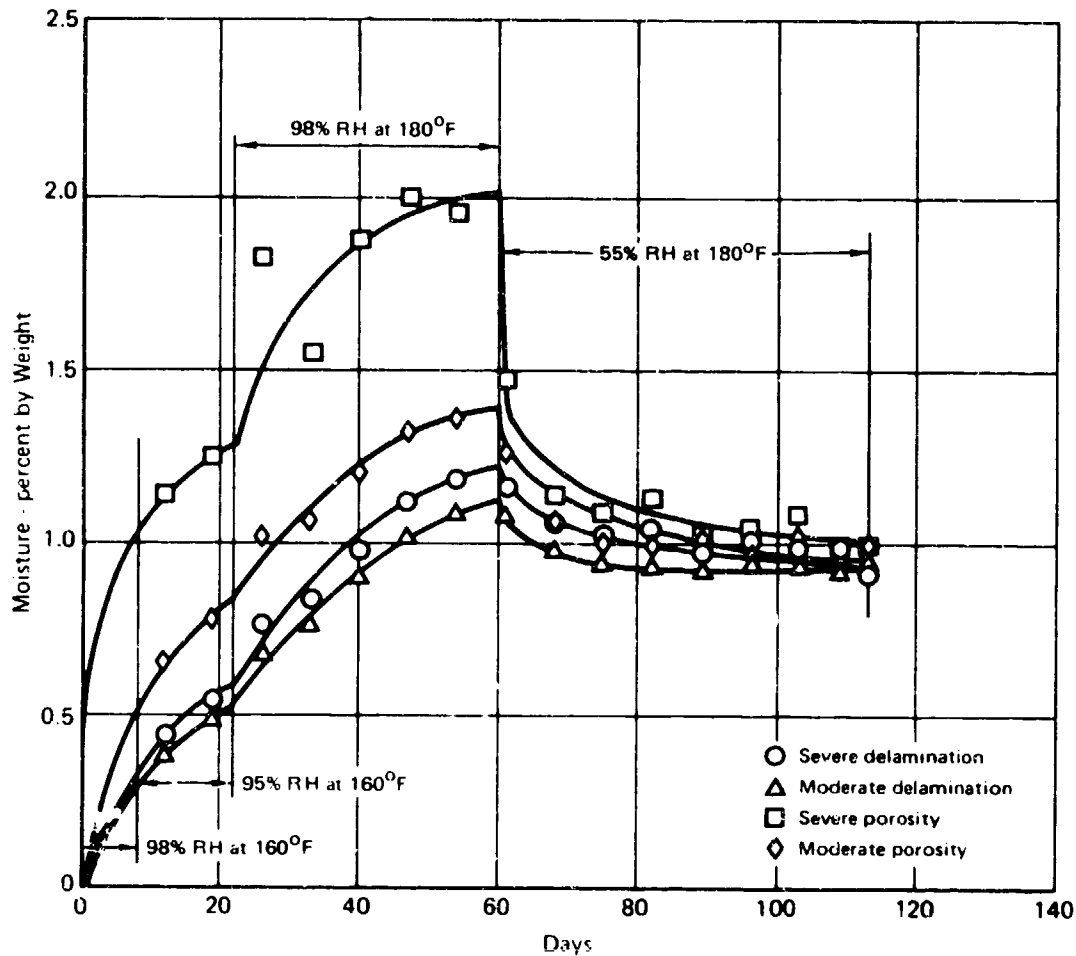
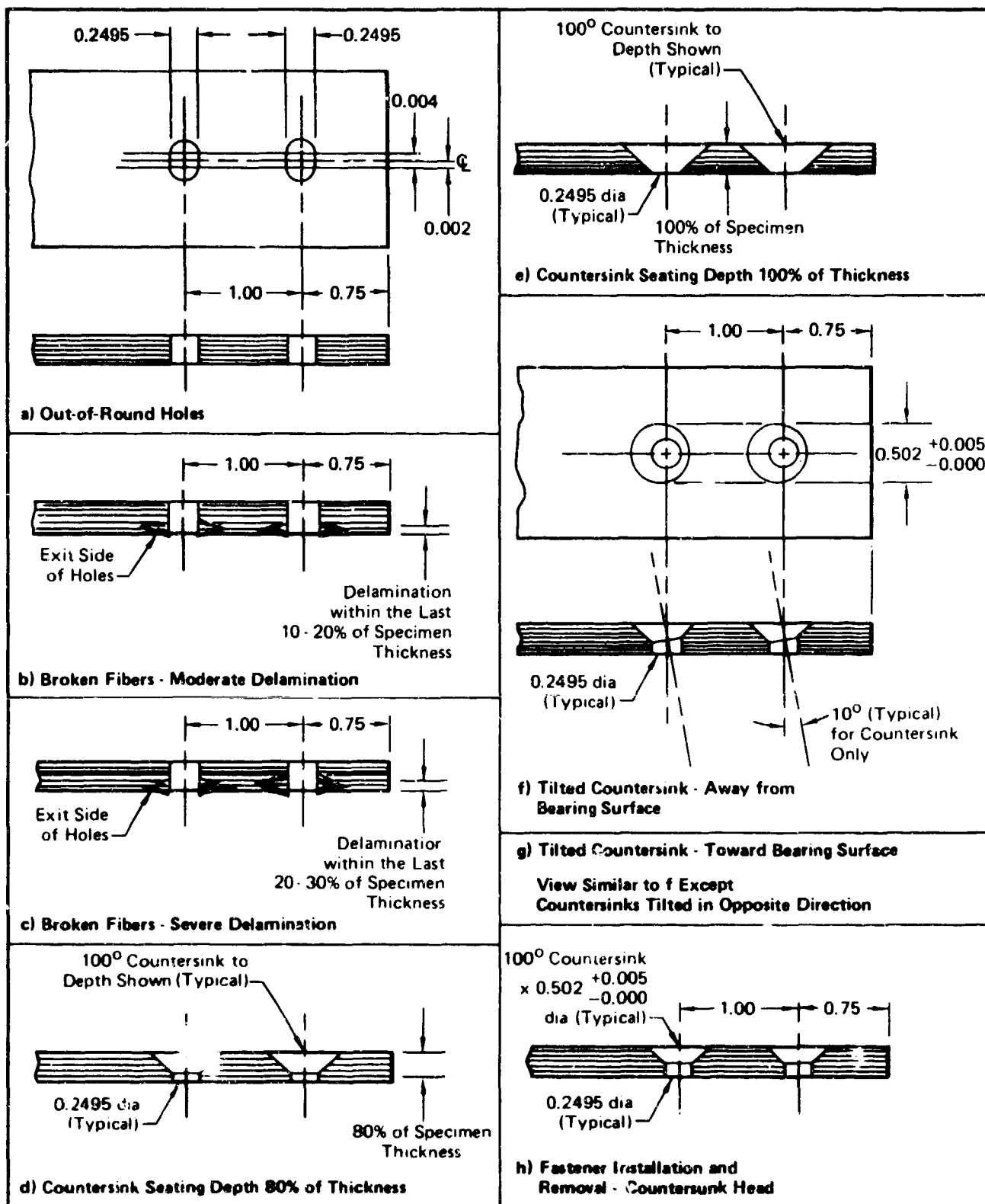

Figure 31. Average Moisture Content for Task 3 Specimens

7. TEST EQUIPMENT - Task 3 testing was accomplished with the same equipment used in Task 2 (Section II.7). Two load blocks were used in this task, the baseline load block used for all but interference fit fasteners and a two strap titanium load block configuration used for interference fit fastener testing. Floating bushings were used to obtain torque-up and to simulate protruding head and countersunk fasteners.

8. SPECIAL PROCEDURES - Special fabrication procedures were developed to simulate commonly occurring manufacturing anomalies. A description of each anomaly and the procedures to obtain the anomaly are given in the following paragraphs.

Out-of-round holes were produced by drilling two nominally sized holes .004 inch offset. The holes were elongated perpendicular to the specimen axis (Figure 32a).



GP13-0115-100

Figure 32. Hole Drilling Anomalies

Broken fibers on the exit side of a hole were obtained using improper drilling techniques. Dull drill bits and no backup material was used for these specimens. Moderate laminate delamination in the vicinity of the hole was produced by force feeding drill bits through the last 10 to 20 percent of specimen thickness with severe delaminations produced by force feeding drill bits through the last 20 to 30 percent of specimen thickness (Figures 32b and 32c).

Laminate porosity was obtained by modifying panel layup and cure cycle procedures. Summarized in Table 6 are the procedures varied from the baseline to obtain moderate and severe levels of porosity. Through-the-thickness photomicrographs of bolt hole areas indicates the severity of the porosity induced by the two procedures (Figures 33 and 34). Two moderate porosity and two severe porosity specimens were subjected to freeze-thaw cycling after environmental exposure and prior to testing. The freeze-thaw cycle procedures followed are presented in Figure 35.

TABLE 6. NONSTANDARD PANEL FABRICATION PROCEDURES

Altered Procedure	Specification	Panel Number	
		22	23
Vacuum Debulk	Yes	None	None
Intermediate Temperature Hold	1 hr at 275°F	None	None
Bag Vacuum	0.05 in. Hg	0.8 in. Hg	1.5 in. Hg
Autoclave Pressure	100 psig	50 psig	50 psig
Moisture Induced	None	Every 7th Ply	Every Ply
Results 	Good Panel	Moderate Porosity	Severe Porosity

 Verified by ultrasonic and radiographic NDI

QP13-0116-101

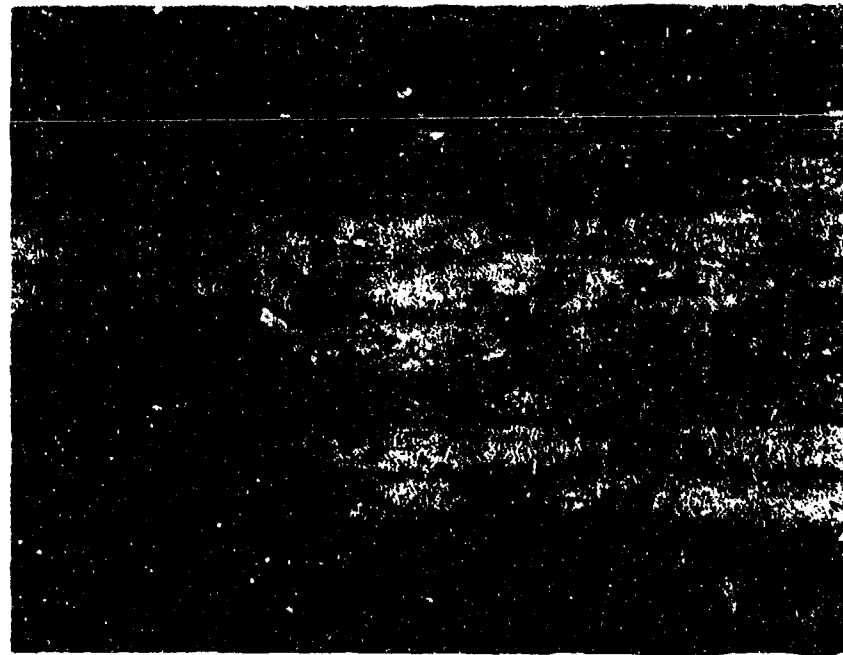

GP13-0115-182

Figure 33. Severe Porosity in Test Specimen Indicated by Photomicrographs

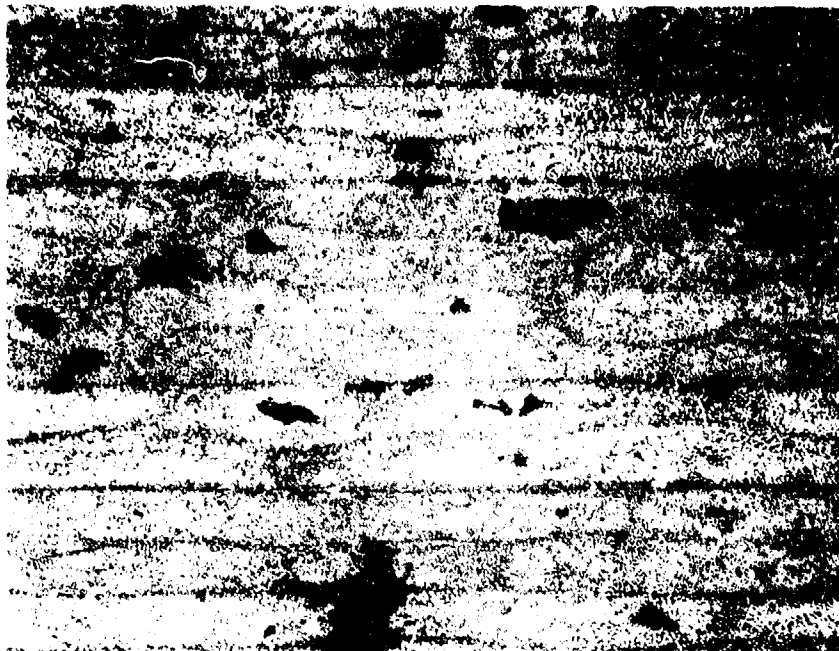

GP13 0115 183

Figure 34. Moderate Porosity in Test Specimen Indicated by Photomicrographs

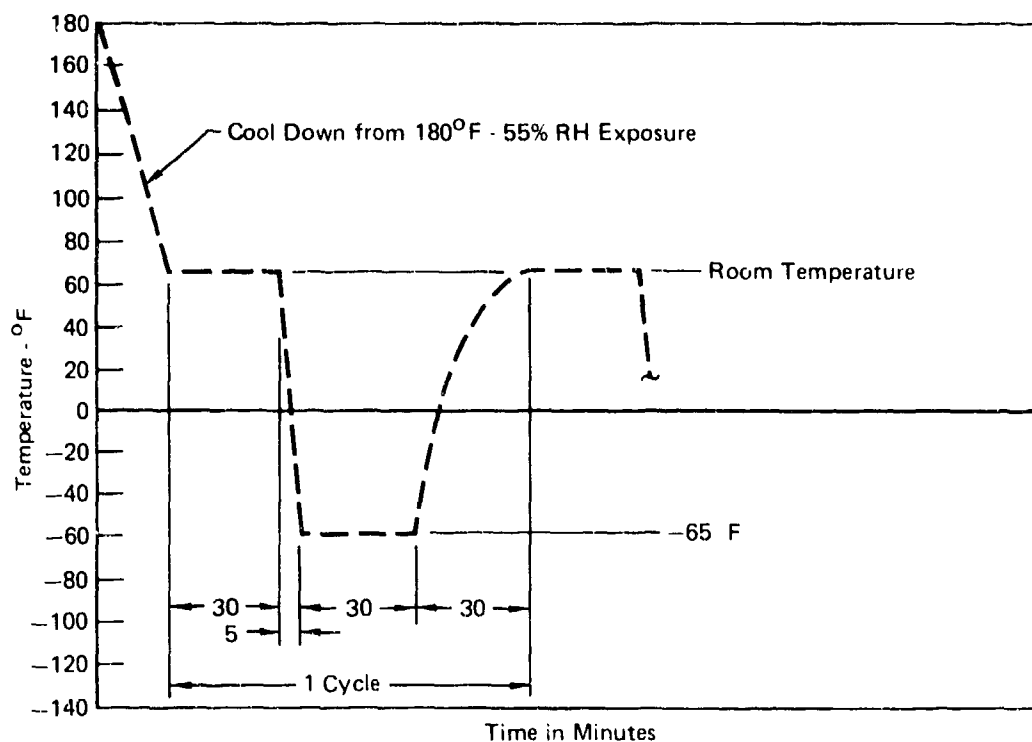

GP13-0115-9

Figure 35. Freeze-Thaw Exposure Profile

Countersunk head depths of 80% and 100% of the laminate thickness were drilled to determine their effect on laminate bearing strength (Figures 32d and 32e). Standard drilling procedures preclude such knife edges.

Tilted countersinks were drilled 10° off the normal to the surface as illustrated in Figure 32f. Initially, clearance fit holes were nominally drilled perpendicular to the laminate surface. Countersinks were tilted toward and away from the bolt bearing surface of the straight shank hole.

Two interference fit levels were investigated in Task 3. Holes were drilled undersize and fasteners installed by pulling the fastener through the hole and into backup material to avoid delaminations. Section cuts were made to determine the amount of internal damage caused by various amounts of interference. Photomicrographs of the section cuts are presented in Figures 36 through 39.

Bolt Installed from This Side

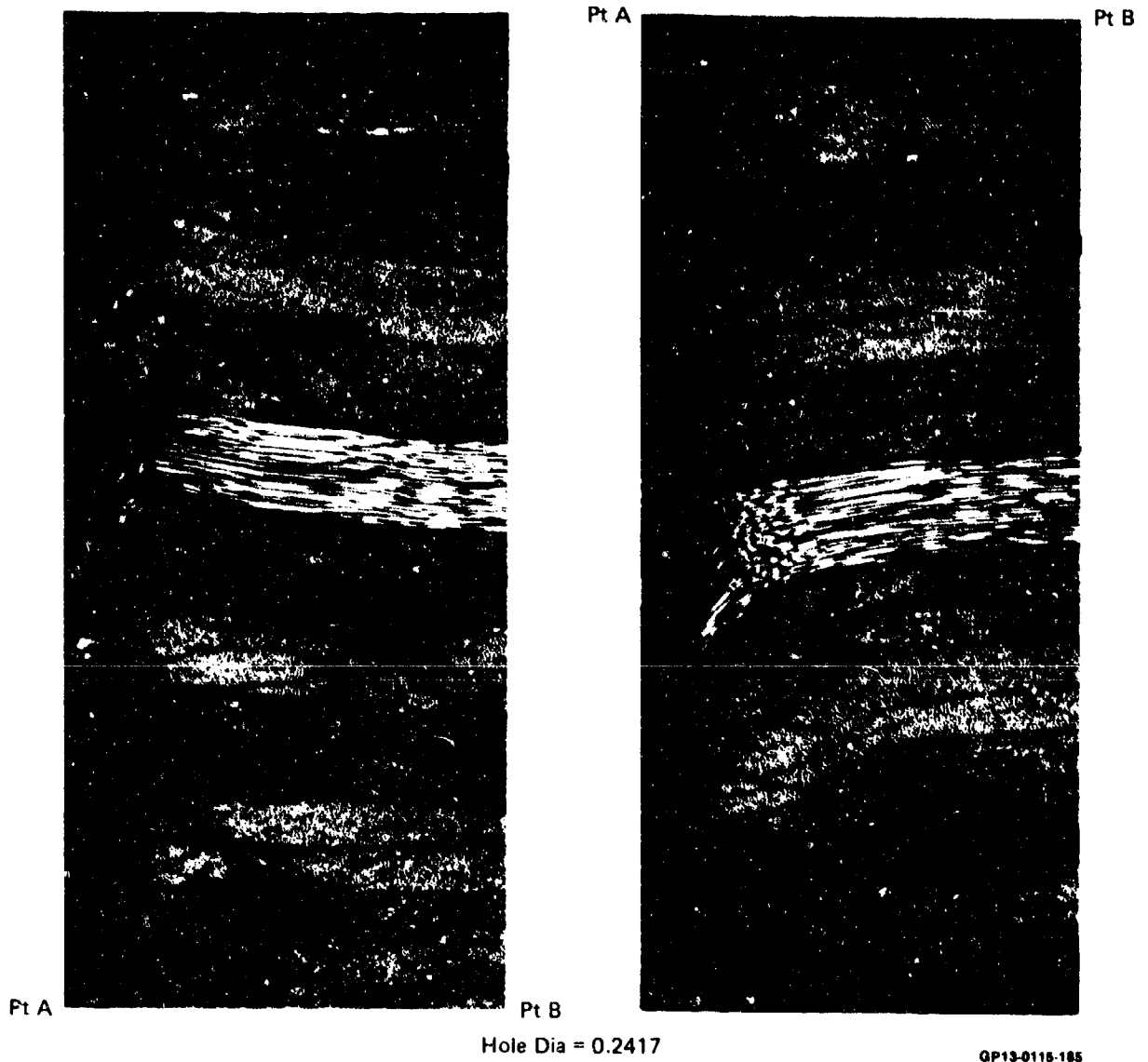
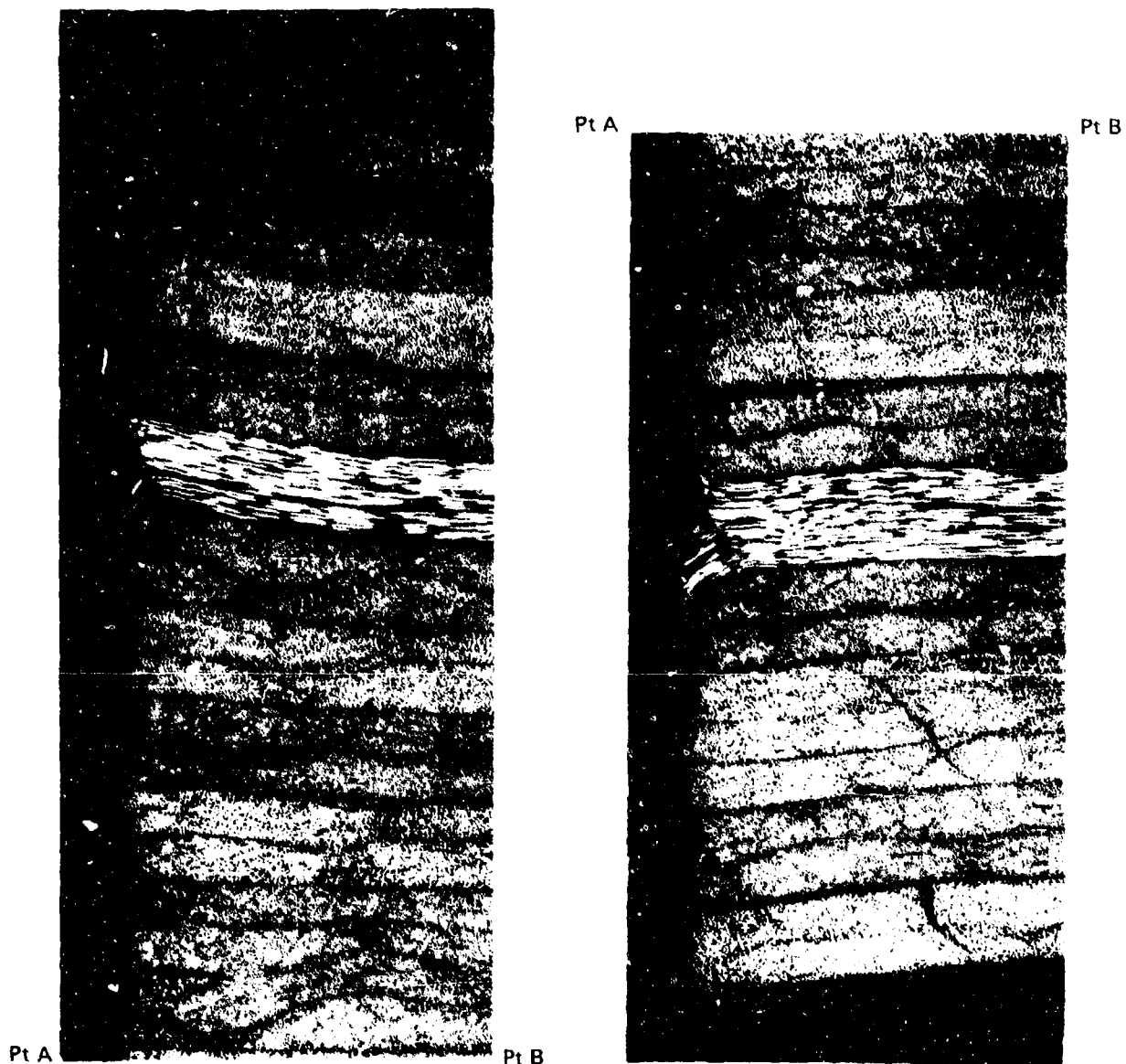

Figure 36. Photomicrographic Results of 0.0072 Inch Interference Fit

Bolt Installed from This Side



Hole Dia = 0.2442

GP13-0115-106

Figure 37. Photomicrographic Results of 0.0053 Inch Interference Fit

Bolt Installed from This Side

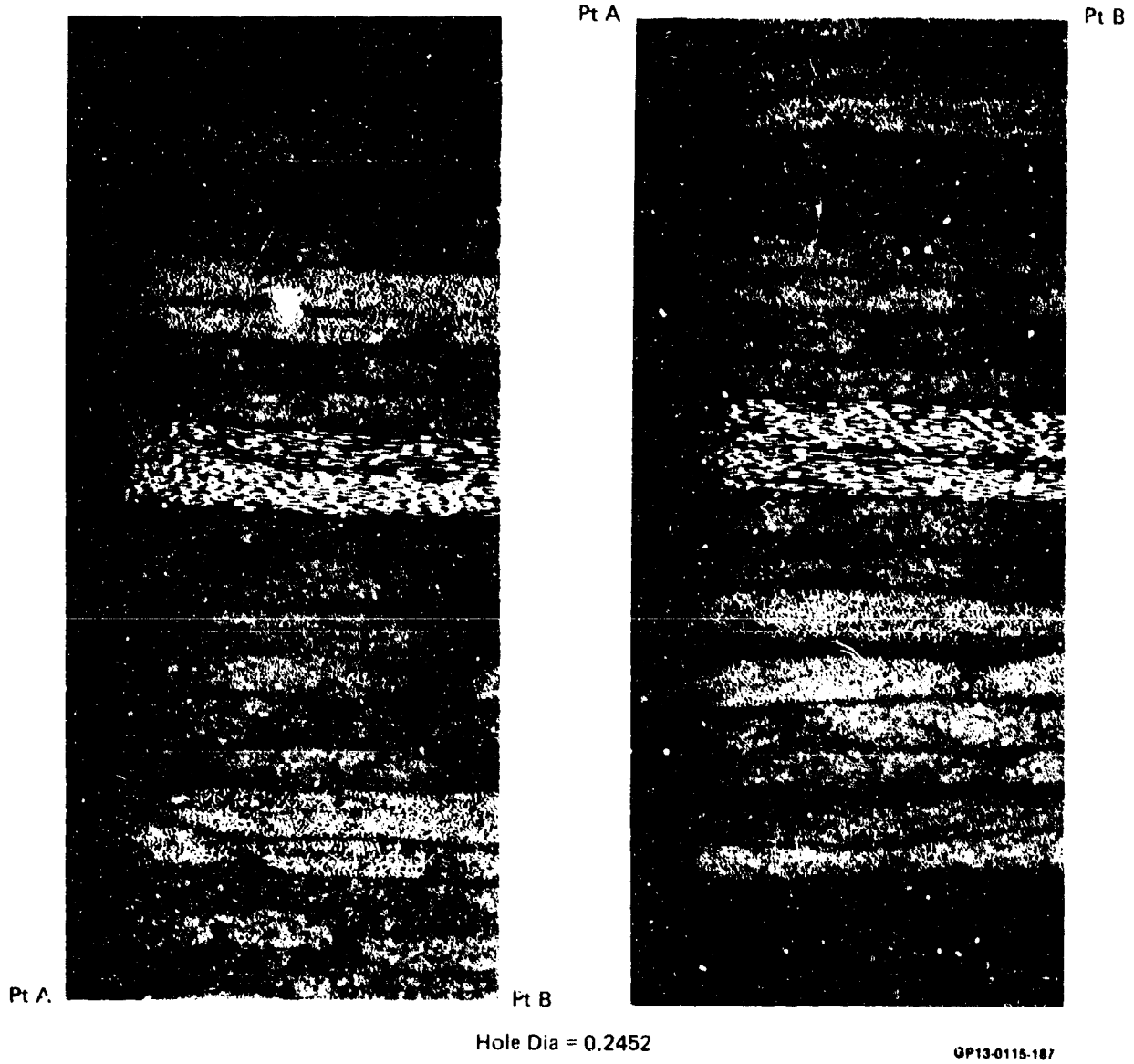

Figure 38. Photomicrographic Results of 0.0043 Inch Interference Fit

Bolt Installed from This Side

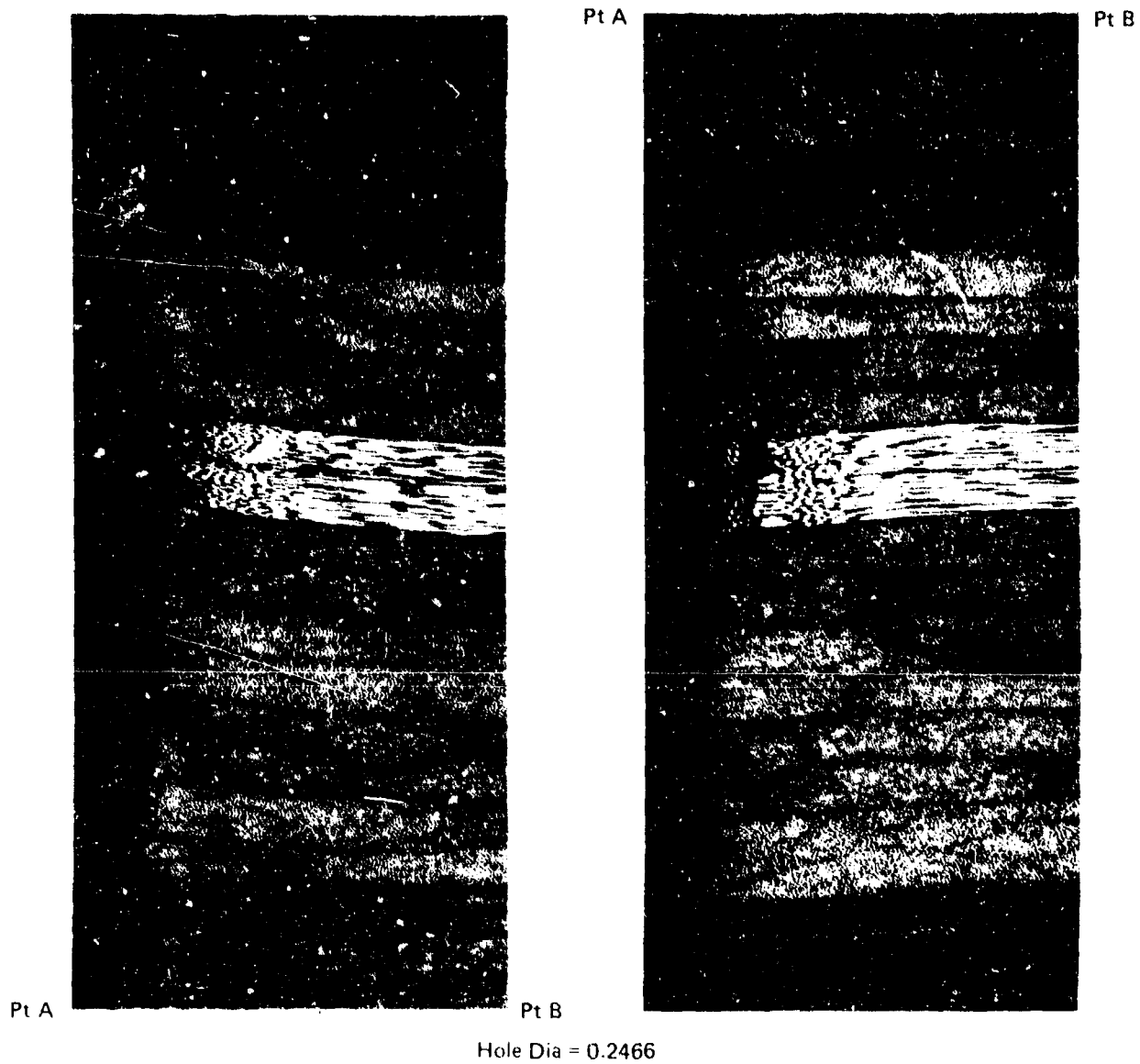

Figure 39. Photomicrographic Results of 0.0030 Inch Interference Fit

Fastener removal and reinstallation of 100 cycles was required for the seventh anomaly. Fasteners were torqued to 50 in-lb for each cycle. Countersunk fasteners were used for this study. Standard hole preparation procedures were used to fabricate these specimens.

To determine and quantify the severity of each anomaly, ultrasonic C-scans were used. Representative C-scans for those variables in which the extent of damage was not mechanically measurable are shown in Figure 40. The interference fit hole in Figure 40 was prior to fastener installation and represents a benchmark to compare the other anomalies to. These C-scans would indicate rejectable items using standard production quality assurance procedures.

9. TEST DATA - All Task 3 test data are presented in this section. Results tabulated include; specimen geometric data, moisture content data, failure loads, failure strains and failure mode information.

Tension and compression strength test data are detailed in Tables 7 and 8 respectively. Test specimen setup configuration figures referenced in the tables are also included (Figure 41). Representative photographs of failed specimens are shown in Figures 42 through 45.

Specimen Number 6-21-3

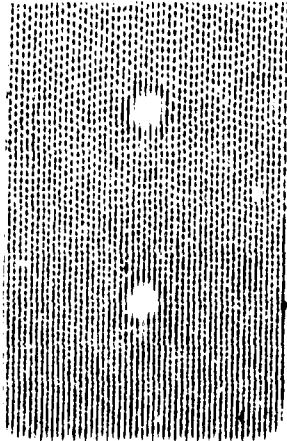

**Interference
Fit 0.2465
Dia Holes**

Specimen Number 2-20-12

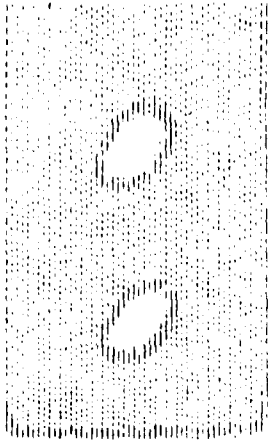

**Broken Fibers
Moderate
Delamination**

Specimen Number 2-20-2

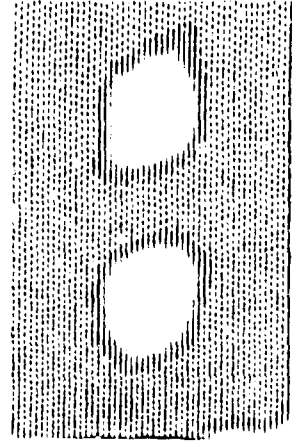

**Broken Fibers
Severe
Delamination**

Specimen Number 3-22-4

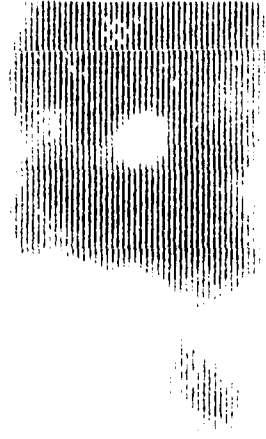

**Severe
Porosity**

Specimen Number 3-23-1

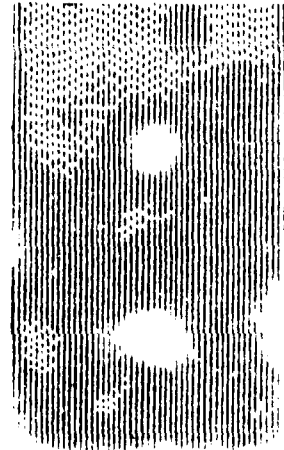

**Moderate
Porosity**

GP13-0115-100

Figure 40. Ultrasonic "C"-Scans of Test Specimen Anomalies

TABLE 7. TENSION STRENGTH TEST DATA

Specimen Number	Specimen and Test Setup Configurations (See Figures)	Percent 90°/45°/90° Piles	Test Variable	Moisture Content (% by Wt)	Test Temp	Fastener Torque (in.-lb)	Thickness (in.)	Width (in.)	Hole Dia (in.)	Failing Load (lb)		Strain at Failure (μ.in./in.)		Mode of Failure
										Individual	Average	Individual	Average	
1-20-36(1)	29A, 41A	50/40/10	Out-of-Round Holes				0.2234	1.511	0.2515	14,100	4,030	4,014	⑦	
1-20-36(2)										13,900	4,080	4,014		
1-20-36(3)										14,100	4,015	S = 62		
1-20-36(4)										13,875	3,930			
1-21-7(1)	29B, 41A	30/60/10				0.2066	1.507	0.2531	14,200	5,610	5,203	③		
1-21-7(2)									12,850	5,210	5,203			
1-21-7(3)									12,300	4,870	S = 307			
1-21-7(4)									13,000	5,120				
2-20-38(1)	29B, 41A		Broken Fibers Moderate Delam.			0.2220	1.509	0.2538	13,710	3,875	3,794	④ - ①		
2-20-38(2)									13,820	4,045	3,794			
2-20-38(3)									12,300	3,615	S = 204			
2-20-38(4)									12,750	3,640				
2-20-34(1)	29C, 41A		Broken Fibers Severe Delam.			0.2226	1.507	0.2503	13,800	3,975	3,663	④ - ②		
2-20-34(2)									13,060	3,855	3,663			
2-20-34(3)									11,100	3,158	S = 441			
2-20-34(4)									11,825	3,460				
3-22-3	29L, 41A		Severe Porosity		RT		0.2186	1.506	0.2543	13,220	3,875	3,940	④ - ①	
3-22-16										13,810	4,080	3,940		
3-22-9										13,220	3,885	S = 95		
3-22-2										13,440	3,920			
4-20-43(1)	29D, 41B	50/40/10	C'rank Bolt Seating Depth 80% of Thickness			0.2159	1.506	0.2499	11,540	3,330	3,238	① - ④ - ①		
4-20-43(2)									11,060	3,225	3,238			
4-20-43(3)									10,940	3,275	S = 89			
4-20-43(4)									11,275	3,120				
4-20-33(1)	29E, 41B		C'rank Bolt Seating Depth 100% of Thickness			0.2231	1.510	0.2668	7,830	2,295	2,543	① - ④ - ①		
4-20-33(2)									8,920	2,730	2,543			
4-20-33(3)									8,980	2,575	S = 181			
4-20-33(4)									9,300	2,570				
5-20-35(1)	29F, 41B		Tilted C'rank Away from Bearing Surface			0.2229	1.513	0.2514	13,430	3,990	3,910	④ - ①		
5-20-35(2)									13,850	4,210	3,910			
5-20-35(3)									13,400	3,880	S = 271			
5-20-35(4)									13,600	3,560				

GP13-0115-100

TABLE 7. (Continued) TENSION STRENGTH TEST DATA

Specimen Number	Specimen and Test Setup Configurations (See Figures)	Percent 0°/45°/90° Plies	Test Variable	Moisture Content (% by Wt)	Test Temp	Fastener Torque (in. lb)	Thickness (in.)	Width (in.)	Hole Dia (in.)	Failing Load (lb)		Strain at Failure (μ in./in.)		Mode of Failure
										Individual	Average	Individual	Average	
5-20-39(1)	29G, 41B		Tilted C-sink Toward Bearing Surface				0.2199	1.510	0.2505	10,340	2,715	3,036	④ - ①	
5-20-39(2)										11,320	3,090	S = 227		
5-20-39(3)										11,380	3,090	S = 482		
5-20-39(4)										10,875	3,250	S = 482		
6-20-44(1)	29H, 41A		Interference Fit 0.2465 Dia	NA	R.T.		0.2201	1.506	0.2481	13,710	3,945	4,003	④ - ①	
6-20-44(2)										14,140	4,065	S = 341		
6-20-44(3)										13,600	3,965	S = 341		
6-20-44(4)										13,320	4,035	S = 341		
5-20-40(1)	29I, 41A	5/40/10	Interference Fit 0.2415 Dia				0.2204	1.503	0.2571	13,980	4,050	4,025	④ - ②	
6-20-40(2)										13,580	3,905	S = 435		
6-20-40(3)										13,700	4,130	S = 435		
6-20-40(4)										12,950	4,015	S = 435		
6-20-42	29M, 41C		Interference Fit 0.2465 Dia	0.91	250°F	50	0.2148	1.512	0.2450	11,520	3,570	3,279	④ - ②	
6-20-21										11,290	2,535	S = 391		
6-20-26										11,860	3,680	S = 391		
6-20-25										10,930	3,330	S = 391		
6-20-3	29N, 41C		Interference Fit 0.2415 Dia	0.82			0.2093	1.511	0.2954	11,160	3,415	3,420	④ - ②	
6-20-19										10,810	3,195	S = 273		
6-20-27										11,700	3,805	S = 273		
6-20-4										10,420	3,265	S = 273		
6-21-8(1)	29H, 41A	30/60/10	Interference Fit 0.2465 Dia	NA	R.T.		0.2048	1.505	0.2488	13,660	5,500	5,464	③	
6-21-8(2)										13,160	5,345	S = 185		
6-21-8(3)										13,700	5,710	S = 185		
6-21-8(4)										12,680	5,300	S = 185		
6-21-9(1)	29I, 41A		Interference Fit 0.2415 Dia				0.2028	1.504	0.2430	12,680	5,430	5,483	④	
6-21-9(2)										12,520	5,390	S = 128		
6-21-9(3)										12,810	5,630	S = 128		
6-21-9(4)										12,240	Gage Failed	S = 128		
6-21-3	29M, 41C		Interference Fit 0.2465 Dia	0.84	250°F		0.2045	1.506	0.2456	10,820	4,660	4,818	④ - ①	
6-21-5										10,840	4,355	S = 543		
6-21-2										11,980	5,050	S = 543		
6-21-11										11,150	5,205	S = 543		

GPT-1015-197

TABLE 7. TENSION STRENGTH TEST DATA

Specimen Number	Specimen and Test Setup Configurations (See Figures)	Percent 0°/45°/90° Plies	Test Variable	Moisture Content (% by Wt)	Test Temp	Fastener Torque (in. -lb)	Thickness (in.)	Width (in.)	Hole Dia (in.)	Failing Load (lb)		Strain at Failure (μ in./in.)		Mode of Failure
										Individual	Average	Individual	Average	
6-21-1				0.85			0.2059	1.506	0.2421	0.2421	10,560	4,295		7
6-21-10	29N, 41C	30/60/10	Interference Fit	0.86	250°F		0.2026	1.470	0.2422	0.2418	10,980	5,100	4,620	4
6-21-6			0.2415 Dia	0.88			0.2131	1.505	0.2421	0.2425	10,920	4,380	S = 363	4 - 1
6-21-4				0.89			0.2113	1.506	0.2422	0.2422	11,000	4,695		4 - 1
7-20-37(1)	29J, 41A		Fastener Removal, Install and Remove Fastener 100 Times	NA	R. T.	50	0.2195		0.2520	0.2535	13,450	4,080		4 - 1
7-20-37(2)							0.2501	0.2502	14,640	4,245		4 - 2		
7-20-37(3)	29K, 41B						0.2502	0.2502	13,700	3,935		4 - 2		
7-20-37(4)							0.2502	0.2500	12,000	3,420	13,246	3,502		
7-20-37(R)(1)	29J, 41A	50/40/10					0.2500	0.2500	0.2500	14,006	4,230	S = 706	4 - 1	
7-20-37(R)(2)							0.2503	0.2498	0.2498	13,550	3,925		4 - 1	
7-20-37(R)(3)							0.2508	0.2500	0.2500	13,380	4,150		4 - 2	
7-20-37(R)(4)	29K, 41B						0.2108	1.504	0.2499	0.2501	13,600	4,080		4 - 2

Notes:

△ Hole diameter dimension legend

Indicates That Holes Were Countersunk

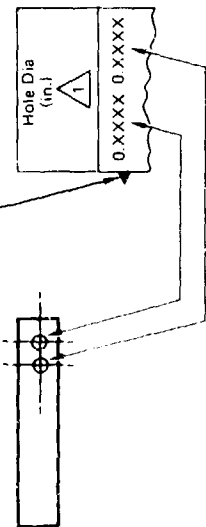

Dimensions noted in tabulation for out-of-round hole are those for the minor diameter. Major diameter dimensions that were obtained were as follows:

Specimen No.	Hole Diameter (in.)
1-20-36(2)	0.2570
1-20-36(3)	0.2562
1-20-36(4)	0.2575
1-21-7(2)	0.2560
1-21-7(3)	0.2561
1-21-7(4)	0.2575

TABLE 7. (Concluded) TENSION STRENGTH TEST DATA

- 2 $e/d=3$ for all specimens
- 3 $w/d=6$ for all specimens
- 4 20 ply thickness for all specimens
- 5 $4d$ hole spacing for all specimens
- 6 AS/3501-6 graphite/epoxy prepreg material used for all specimens
- 7 Mode of failure legend: 4 - 1 implies a combination on bearing-shearout mode of failure.

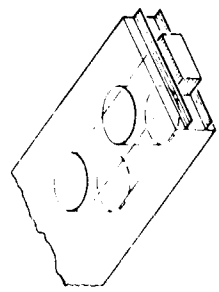

1 Shear-out mode. 0° and 90° plies "pushed" out in front of bolt hole.

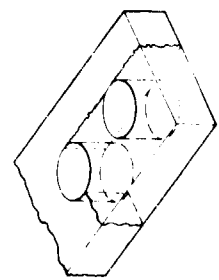

2 Tension-cleavage mode. Net section and shearout combination. Failure extends along shearout path and net section path.

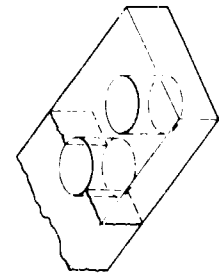

3 Net section mode. Failure only in net section area.

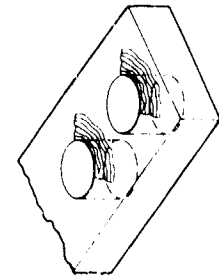

4 Bearing mode. Failure localized directly in front of bolt.

GP13-0115-258

TABLE 8. COMPRESSION STRENGTH TEST DATA

Specimen Number	Specimen and Test Setup Configurations (See Figures)	Percent 0°/45°/90° Plies	Test Variable	Moisture Content (% by Wt)	Test Temp	Fastener Torque (in. lb)	Thickness (in.)	Width (in.)	Hole Dia (in.)	Failing Load (lb)		Strain at Failure (μ.in./in.)		Mode of Failure
										Individual	Average	Individual	Average	
2-20-12	29P, 41A		Broken Fibers Moderate Delam	0.90	RT	50	0.2108	1.503	0.2533	0.2532	14,700	4,850	4,445	①
2-20-20							0.2161	1.501	0.2541	0.2532	15,000	4,540	4,445	
2-20-22							0.2200	1.505	0.2534	0.2532	13,500	4,030	S = 343	
2-20-6							0.2059	1.506	0.2523	0.2531	14,120	4,360		
2-20-41	29Q, 41A		Broken Fibers Severe Delam	0.99	RT	50	0.2234	1.517	0.2511	0.2531	14,370	4,960	4,575	①
2-20-2							0.2015	1.508	0.2506	0.2512	12,800	4,600	4,575	
2-20-29							0.2135	1.491	0.2504	0.2506	13,200	4,480	S = 293	
2-20-10							0.2097	1.504	0.2533	0.2511	13,940	4,260		
2-20-24	29P, 41A		Broken Fibers Moderate Delam	0.94	250°F	50	0.2165	1.504	0.2531	0.2531	11,720	3,675	3,811	①
2-20-30							0.2242	1.492	0.2527	0.2537	11,550	4,020	3,811	
2-20-45							0.2223	1.513	0.2536	0.2544	10,400	3,800	S = 148	
2-20-28							0.2197	1.501	0.2540	0.2532	10,280	3,750		
2-20-14	29Q, 41A		Broken Fibers Severe Delam	0.92	250°F	50	0.2156	1.502	0.2507	0.2506	10,200	3,175	3,326	①
2-20-46							0.2118	1.511	0.2498	0.2512	11,080	3,505	3,326	
2-20-5							0.2043	1.506	0.2501	0.2508	9,600	3,180	S = 174	
2-20-18							0.2183	1.505	0.2512	0.2518	10,790	3,445		
3-22-8	29L, 41A	50/40/10	Severe Porosity	0.89	RT	50	0.2142	1.505	0.2530	0.2540	12,580	3,940	4,139	①
3-22-15							0.2159	1.510	0.2506	0.2507	13,500	4,280	4,139	
3-22-5							0.2281	1.510	0.2510	0.2511	13,420	4,265	S = 163	
3-22-4							0.2187	1.508	0.2516	0.2529	13,140	4,070		
3-23-5	29R, 41A		Moderate Porosity	0.99	RT	50	0.2116	1.504	0.2535	0.2524	13,060	4,130	4,425	①
3-23-9							0.2146	1.502	0.2547	0.2550	14,080	4,605	4,425	
3-23-1							0.2096	1.504	0.2535	0.2571	14,220	4,825	S = 347	
3-23-7							0.2131	1.504	0.2525	0.2541	14,100	4,140		
3-22-7	29L, 41A		Severe Porosity	1.00	RT	50	0.2269	1.505	0.2537	0.2541	6,420	1,975	2,554	②
3-22-10							0.2147	1.507	0.2516	0.2516	7,260	2,430	2,554	
3-22-12							0.2190	1.507	0.2508	0.2510	8,960	2,975	S = 450	
3-22-14							0.2174	1.509	0.2520	0.2517	9,140	2,835		
3-23-8	29R, 41A		Moderate Porosity	0.96	250°F	50	0.2184	1.504	0.2515	0.2520	9,780	3,060	3,111	①
3-23-10							0.2184	1.502	0.2520	0.2522	10,200	3,189	3,111	
3-23-6							0.2175	1.504	0.2514	0.2526	10,130	3,155	S = 66	
3-23-4							0.2191	1.506	0.2531	0.2524	9,660	3,050		

GP13-0115-1B2

TABLE 8. (Concluded) COMPRESSION STRENGTH TEST DATA

Specimen Number	Specimen and Test Setup Configurations (See Figures)	Percent 0°/45°/90° Piles	Test Variable	Moisture Content (% by Wt)	Test Temp	Fastener Torque (in.-lb)	Thickness (in.)	Width (in.)	Hole Dia (in.)	Failing Load (lb)		Strain at Failure ($\mu\text{in./in.}$)		Mode of Failure
										Individual	Average	Individual	Average	
5-20-11	28S, 41B		Tilted C'sink Away from Bearing Surface	0.82	250°F	50	0.2137	1.503	0.2515	0.2520	10,080	2,970		⑦
5-20-7				0.88			0.2088	1.504	0.2517	0.2514	9,550	3,030	2,994	
5-20-9				0.88			0.2082	1.505	0.2505	0.2507	9,500	2,650		
5-20-15				0.93			0.2176	1.501	0.2510	0.2502	9,940	3,285		
5-20-16	29T, 41B	50/40/10	Tilted C'sink Toward Bearing Surface	0.92	250°F	50	0.2160	1.501	0.2497	0.2496	10,230	3,145		①
5-20-17				0.90			0.2131	1.505	0.2515	0.2521	10,020	3,095	2,898	
5-20-8				0.90			0.2085	1.503	0.2512	0.2505	9,560	2,770		
5-20-1				0.86			0.2011	1.508	0.2504	0.2513	9,280	2,580		
7-20-23	29U, 41B		Fastener Removal, and Remove Fastener 100 Times	0.92	250°F	50	0.2190	1.504	0.2514	0.2593	11,060	3,910		①
7-20-31				1.01			0.2223	1.490	0.2514	0.2515	10,350	3,585	10,338	
7-20-13				0.87			0.2113	1.502	0.2591	0.2509	10,030	3,315		
7-20-32				1.01			0.2218	1.490	0.2624	0.2629	9,910	3,230		

SP-13415-246

Notes:

① Hole diameter dimension legend: ④ Mode of failure legend: ⑦ implies a combination bearing-shearout mode of failure.

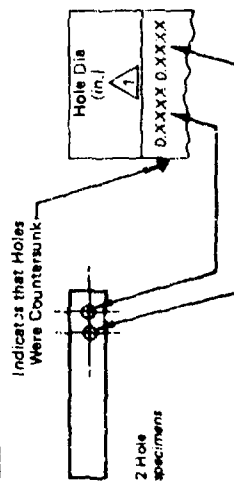

② e/d=3 for all specimens

③ w/d=6 for all specimens

④ 20 ply thickness for all specimens

⑤ 4d hole spacing for all specimens

⑥ AS/3501-6 graphite/epoxy prepreg material used for all specimens

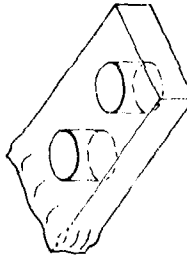

① Bearing mode. Failure localized directly in front of bolt.

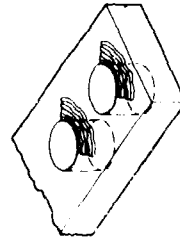

② Block compression beyond holes mode.

③ Specimens were subjected to freeze-thaw cycle procedures.

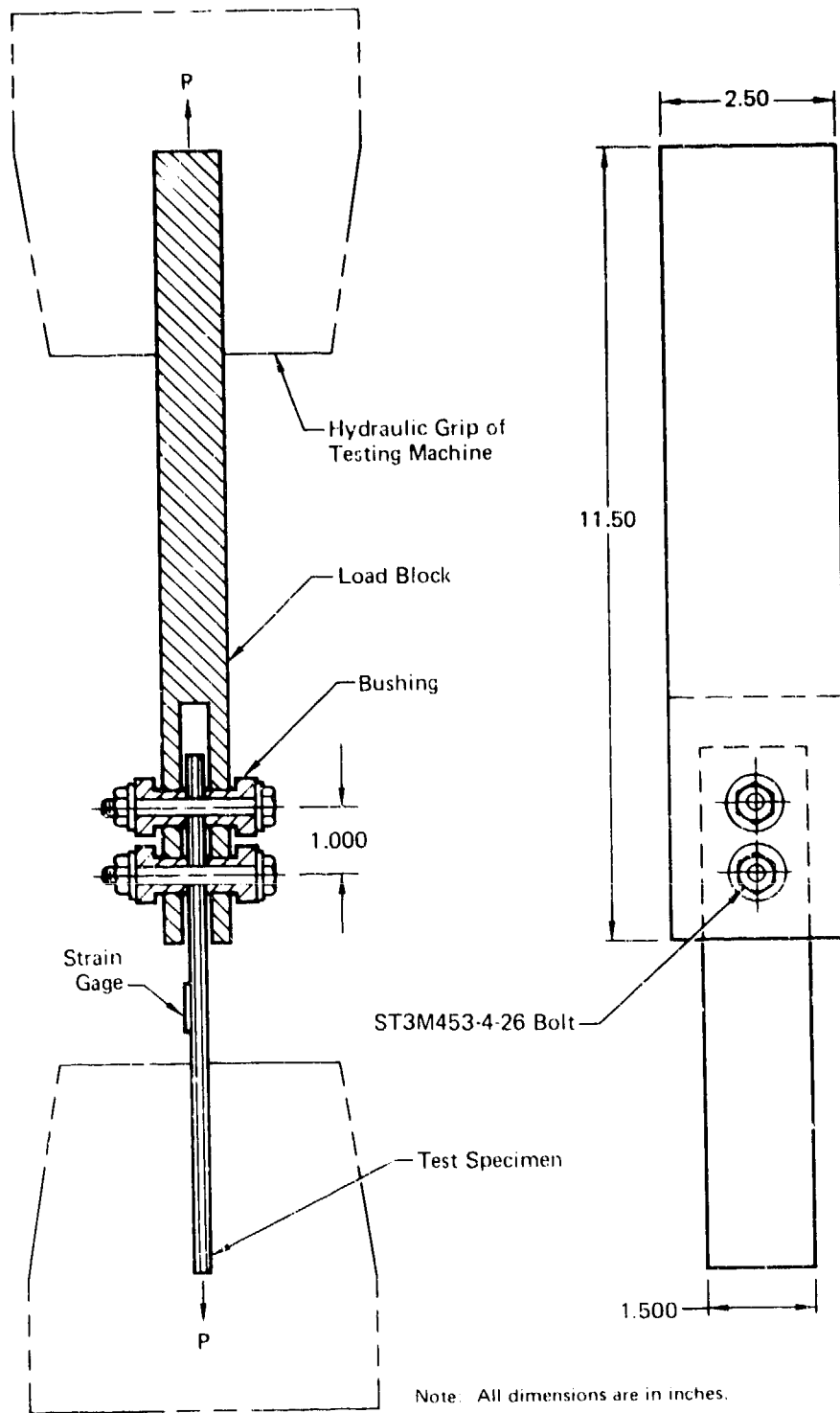

Test Configuration 41A

GP13-0115-193

Figure 41. Task 3 Test Setups

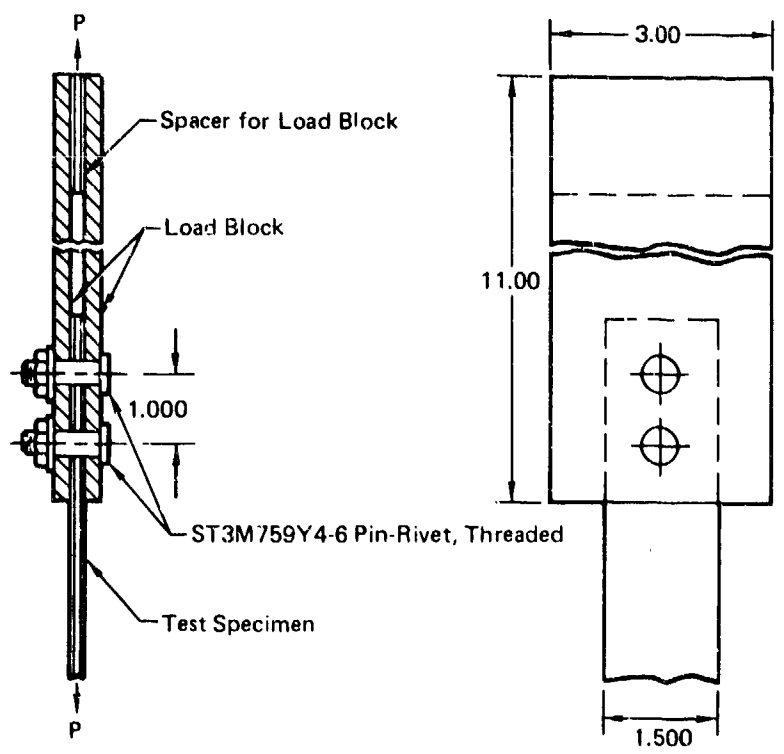
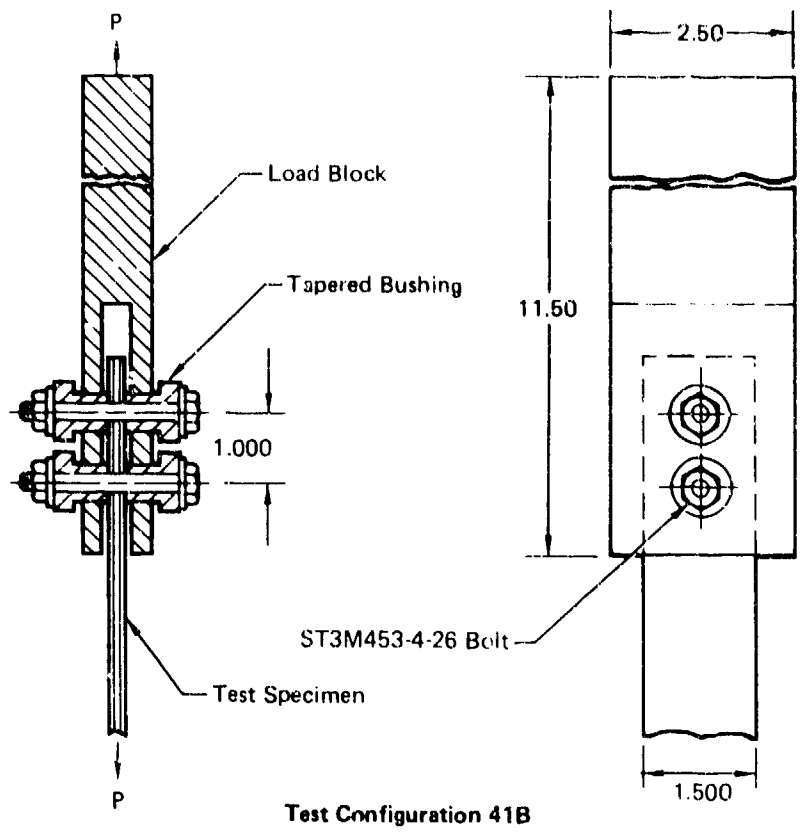

Note: All dimensions are in inches.

QP13-0115-104

Test Configuration 41C
Figure 41. (Continued) Task 3 Test Setups

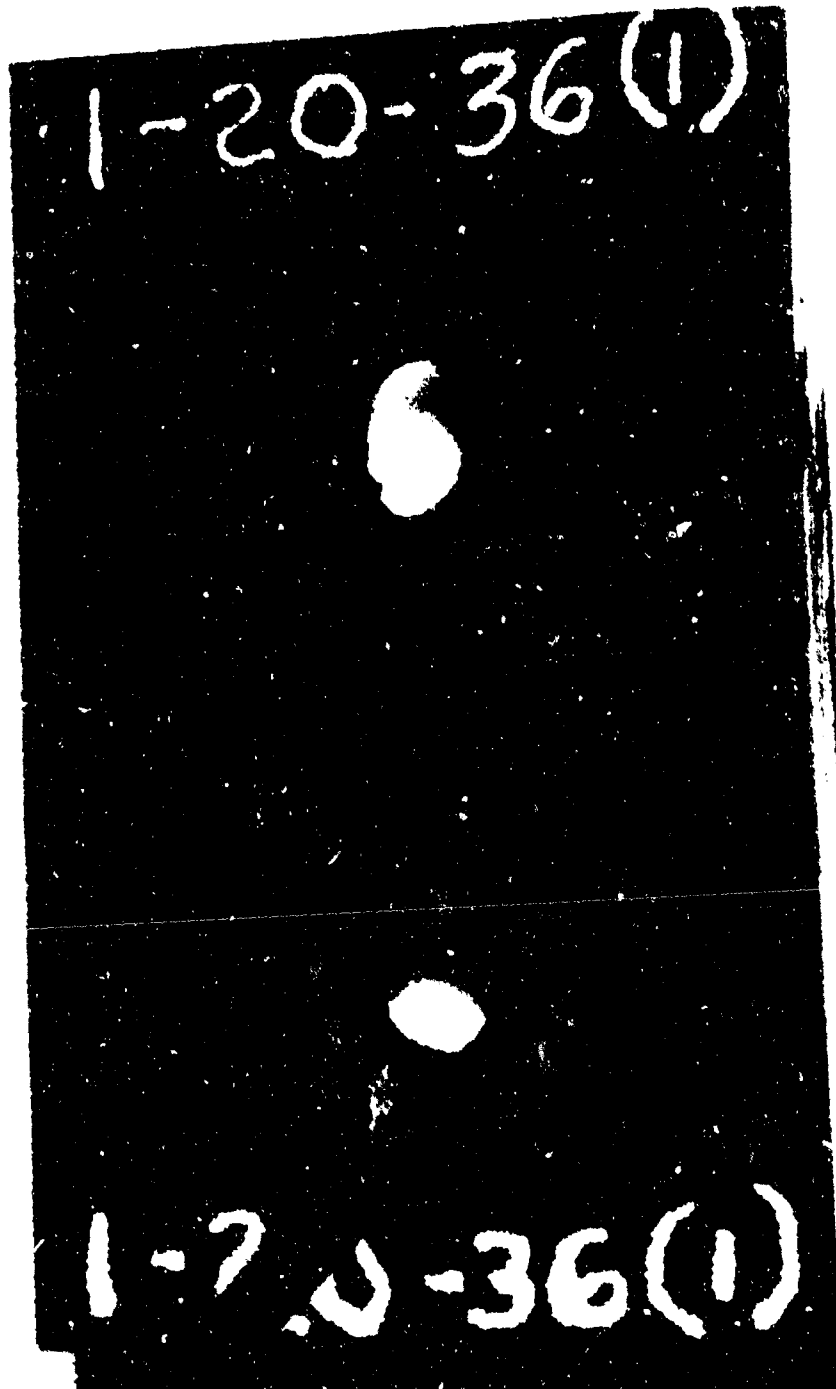

GP13-0115-105

Figure 42. Tension-Cleavage Mode of Failure

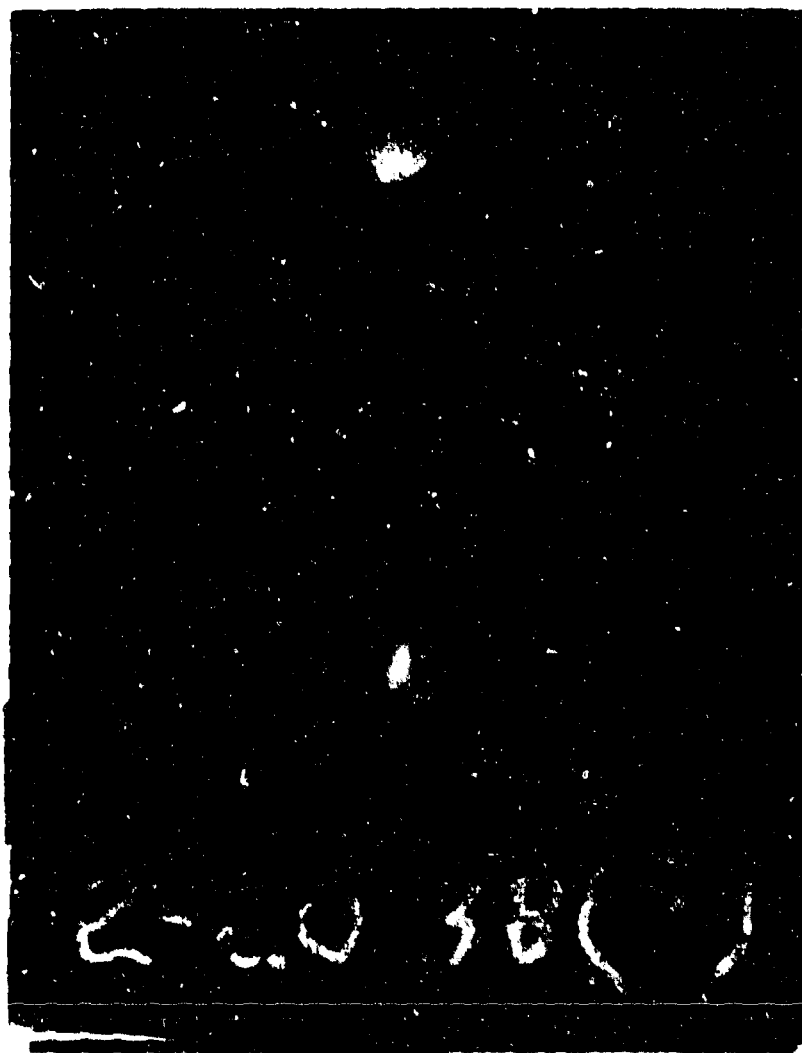

Plan View of Failure

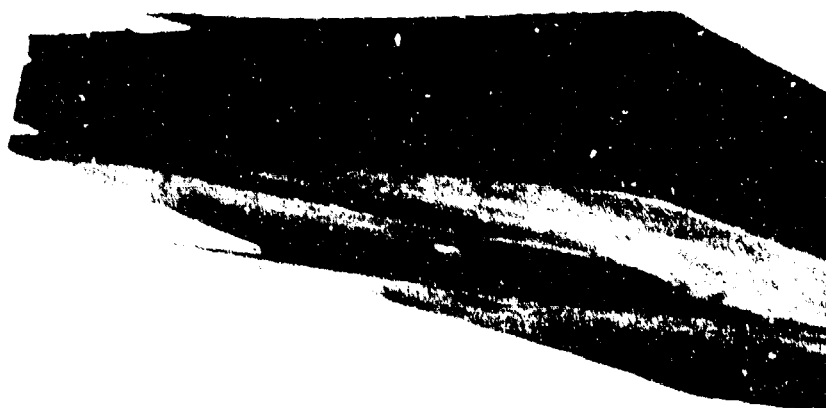

Edge View of Failure

GP13-0115-188

Figure 43. Bearing-Shearout Mode of Failure



Tilted Countersink - Toward
Bearing Surface

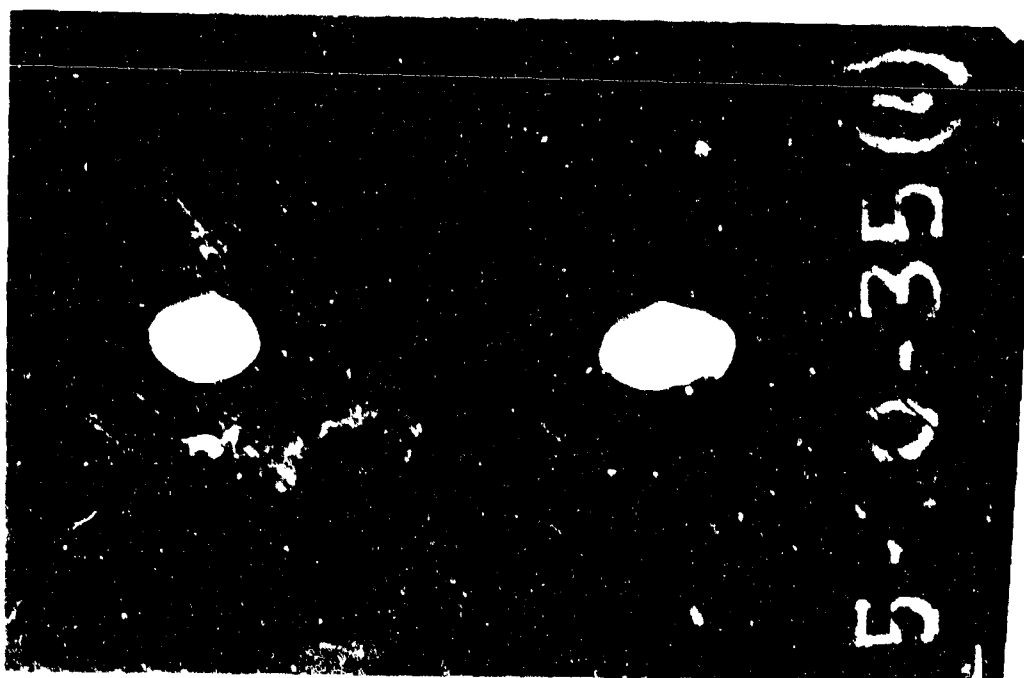

Tilted Countersink - Away from
Bearing Surface

GP13-0115-197

Figure 44. Bearing-Shearout Mode of Failure

Specimen Number 4 20-23

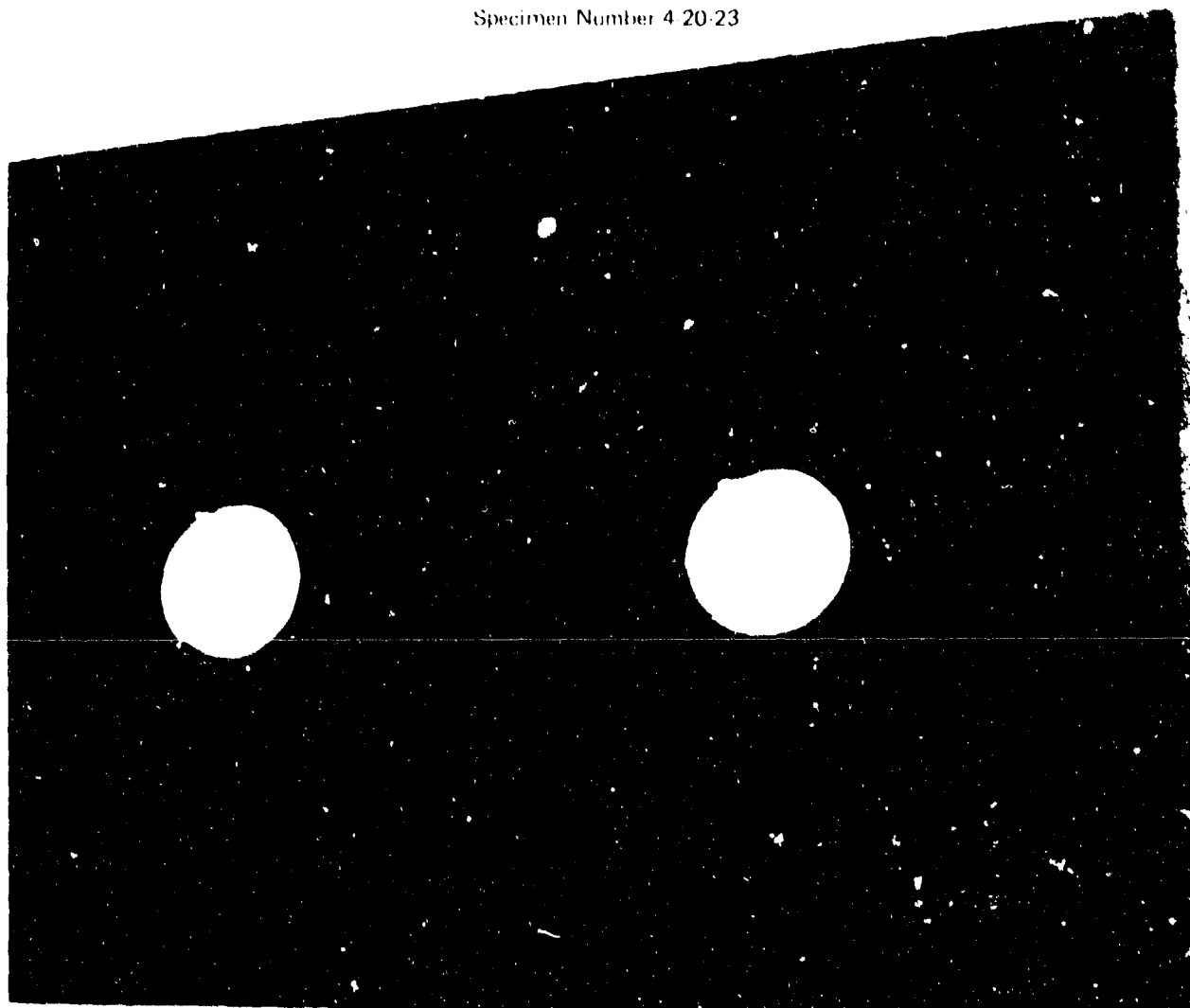

Figure 45. Bearing-Shearout Mode of Failure

GP13-0115-106

SECTION IV

RESULTS OF TASK 4 TESTING - CRITICAL JOINT DESIGN
 VARIABLES ON FATIGUE LIFE

1. TASK 4 - TEST MATRIX AND TEST OBJECTIVE - The objective of Task 4 was to evaluate the influence on fatigue life of seven design variables and manufacturing anomalies which were shown to have a significant effect on static strength in Tasks 2 and 3. The test variables selected and fatigue parameters tested are shown in the Task 4 test matrix of Figure 46.

NO.	TEST VARIABLE	MAX FATIGUE STRESS	NO. OF TESTS CONSTANT AMPLITUDE		NO. OF TESTS SPECTRUM FATIGUE			
			R = +0.1	R = -1.0	RTW	RTD	ETW	RTW(TS)
1	BASELINE 50/40/10 $\triangle 2$ $\triangle 3$	σ_1	3	3	3	3	3	3
		σ_2	3	3	3	3	3	3
		σ_3	3	3	3	3	3	3
		$\triangle 1$	3	-	3	-	3	3
	30/60/10 $\triangle 2$ $\triangle 3$	σ_1	3	3	-	3	-	-
		σ_2	3	3	-	3	-	-
		σ_3	3	3	-	3	-	-
		$\triangle 1$	3	-	-	-	-	-
	19/76/5 $\triangle 2$ $\triangle 3$	σ_1	3	3	-	3	-	-
		σ_2	3	3	-	3	-	-
		σ_3	3	3	-	3	-	-
		$\triangle 1$	3	-	-	-	-	-
2	STACKING SEQUENCE 50/40/10 $\triangle 2$ $\triangle 3$	σ_1	3	3	-	3	-	-
		σ_2	3	3	-	3	-	-
		σ_3	3	3	-	3	-	-
		$\triangle 1$	3	-	-	-	-	-
	19/76/5 $\triangle 2$ $\triangle 3$	σ_1	3	3	-	3	-	-
		σ_2	3	3	-	3	-	-
		σ_3	3	3	-	3	-	-
		$\triangle 1$	3	-	-	-	-	-
3	TORQUE UP T = 160 IN.-LB 50/40/10 $\triangle 2$	σ_1	3	3	-	3	-	-
		σ_2	3	3	-	3	-	-
		σ_3	3	3	-	3	-	-
		$\triangle 1$	3	-	-	-	-	-
	T = 160 IN.-LB 19/76/5 $\triangle 2$	σ_1	3	3	-	3	-	-
		σ_2	3	3	-	3	-	-
		σ_3	3	3	-	3	-	-
		$\triangle 1$	3	-	-	-	-	-

$\triangle 1$ Complementing static tests $\triangle 2$ d = 0.375 in., w/d = 6, e/d = 3 $\triangle 3$ Torque up = 0 in.-lb

GP13-J11E-106

Figure 46. Task 4 - Evaluation of Critical Joint Design Parameters on Fatigue Life - Test Matrix

NO.	TEST VARIABLE	MAX FATIGUE STRESS	NO. OF TESTS CONSTANT AMPLITUDE		NO. OF TESTS SPECTRUM FATIGUE			
			R = +0.1	R = -1.0	RTW	RTD	ETW	RTW(TS)
4	GEOMETRY 50/40/10 $\triangle 3$ d = 0.375 w/d = 4 e/d = 3	σ_1	3	-	-	-	-	-
		σ_2	3	-	-	-	-	-
		σ_3	3	-	-	-	-	-
		$\triangle 1$	3	-	-	-	-	-
	19/76/5 $\triangle 3$ d = 0.375 w/d = 4 e/d = 3	σ_1	3	-	-	-	-	-
		σ_2	3	-	-	-	-	-
		σ_3	3	-	-	-	-	-
		$\triangle 1$	3	-	-	-	-	-
	19/76/5 $\triangle 3$ d = 0.375 w/d = 3 e/d = 3	σ_1	3	-	-	-	-	-
		σ_2	3	-	-	-	-	-
		σ_3	3	-	-	-	-	-
		$\triangle 1$	3	-	-	-	-	-
	50/40/10 $\triangle 3$ d = 0.375 w/d = 4 e/d = 4	σ_1	3	-	-	-	-	-
		σ_2	3	-	-	-	-	-
		σ_3	3	-	-	-	-	-
		$\triangle 1$	3	-	-	-	-	-
5	FASTENER FIT (0.003 -- 0.008 INTERFERENCE) 50/40/10 $\triangle 2$ $\triangle 3$	σ_1	3	-	-	-	-	-
		σ_2	3	-	-	-	-	-
		σ_3	3	-	-	-	-	-
		$\triangle 1$	3	-	-	-	-	-
6	SINGLE SHEAR (PROTRUDING AND CSK) 50/40/10 $\triangle 2$ T = 160 IN.-LB	σ_1	3	-	-	-	-	-
		σ_2	3	-	-	-	-	-
		σ_2	3	-	-	-	-	-
		$\triangle 1$	3	-	-	-	-	-
	d = 0.375 IN. CSK w/d = 6 e/d = 3 T = 160 IN.-LB	σ_1	3	-	-	-	-	-
		σ_2	3	-	-	-	-	-
		σ_3	3	-	-	-	-	-
		$\triangle 1$	3	-	-	-	-	-
7	POROSITY 50/40/10 $\triangle 2$ $\triangle 3$	σ_1	3	3	-	-	-	-
		σ_2	3	3	-	-	-	-
		σ_3	3	3	-	-	-	-
		$\triangle 1$	3	-	-	-	-	-
TOTAL TESTS = 351								

$\triangle 1$ Complementing static tests

$\triangle 2$ d = 0.375 in., w/d = 6, e/d = 3

$\triangle 3$ Torque up - 0 in.-lb

GP13-0115-262

Figure 46. (Continued) Task 4 - Evaluation of Critical Joint Design Parameters on Fatigue Life-Test Matrix

Static, constant amplitude and spectrum fatigue testing was performed. All constant amplitude testing was performed at room temperature with dry (as manufactured) specimens. For the baseline layup (50/40/10) spectrum fatigue testing was performed at four environmental conditions: room temperature dry (RTD), room temperature wet (RTW), elevated temperature wet (ETW), and elevated temperature wet with thermal spike (TS) exposure. Elevated test temperature and moisture preconditioning levels respectively were 250°F and .86% by weight. Two additional layups (30/60/10 and 19/76/5) were selectively tested. A replication of three tests were performed for each variable for a total of 351 tests in Task 4.

2. SPECIMEN CONFIGURATION - The single bolt pure bearing specimen of Task 2 was used to obtain data on bolted composite joint performance under cyclic loading. Baseline specimen geometry is shown in Figure 47. To avoid bolt failures during fatigue testing, 3/8 inch diameter steel fasteners were used. For complementing static tests, specimens were strain gaged to obtain strain and stiffness response data to failure. In Task 4, 54 static tests and 297 fatigue test specimens were required to complete the experimental evaluation of fatigue life of bolted composite joints.

3. SPECIMEN QUALITY ASSURANCE - All quality assurance procedures described in Section II.3 were adhered to in Task 4.

4. PANEL FABRICATION - Ten panels of AS/3501-6 graphite-epoxy were fabricated for Task 4. Panel dimensions, corresponding ply orientations and stacking sequences are listed in Figure 48. To maintain unique panel identification within the entire test program, Task 4 panels were consecutively numbered starting from the last panel number used in Task 3. Layups of 50/40/10 and 30/60/10 were identical to those tested in Tasks 2 and 3. A third, more matrix dominated layup (19/76/5) was evaluated for greater generality of test results.

Nine panels were fabricated per MCAIR process specifications. Panel number 30 was intentionally fabricated to contain a moderate amount of porosity. All panels were evaluated ultrasonically and accepted for testing.

5. SPECIMEN FABRICATION - Specimens were fabricated from the panels per MCAIR process specifications. Identification of each specimen was accomplished using the following code:

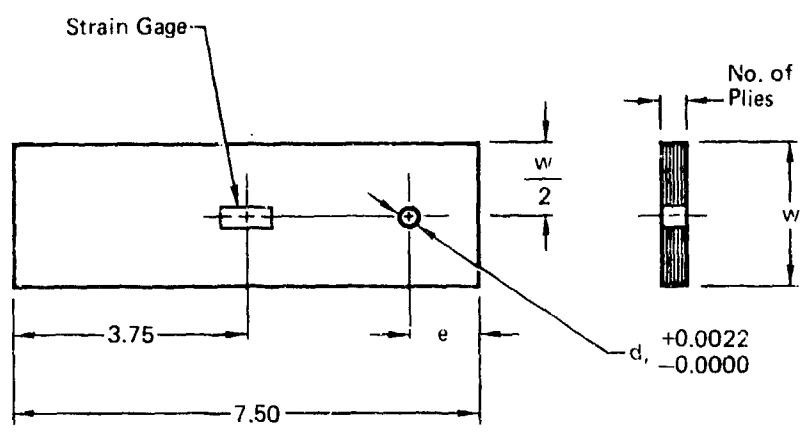

Specimen Configuration	No. of Plies	w (in.)	e (in.)	d, (in.)
47A	21 Plies for Specimen	2.250	1.125	0.3745
47B	Numbers with	1.500	1.125	
47C	31 → 33 as	1.500	1.500	
47D	Their Middle	1.125	1.125	
47E	Number, 20 Plies for All Others	2.250	1.125	0.3693

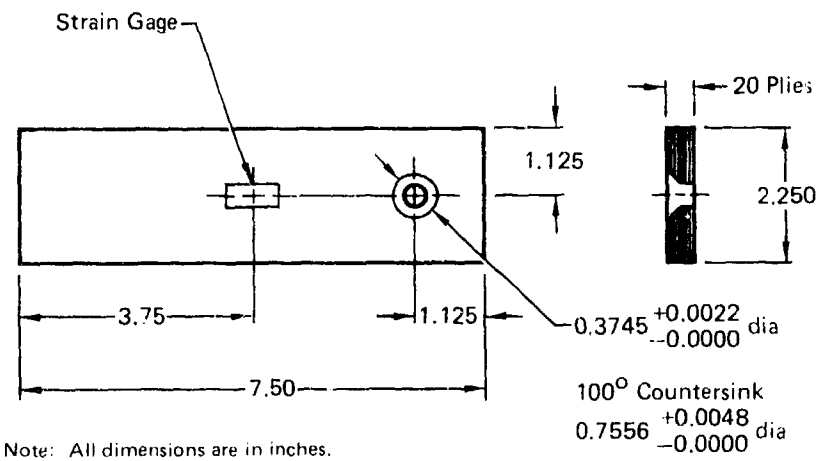

Note: All dimensions are in inches.

Specimen Configuration 47F

QP13-0115-109

Figure 47. Fatigue Test Specimens

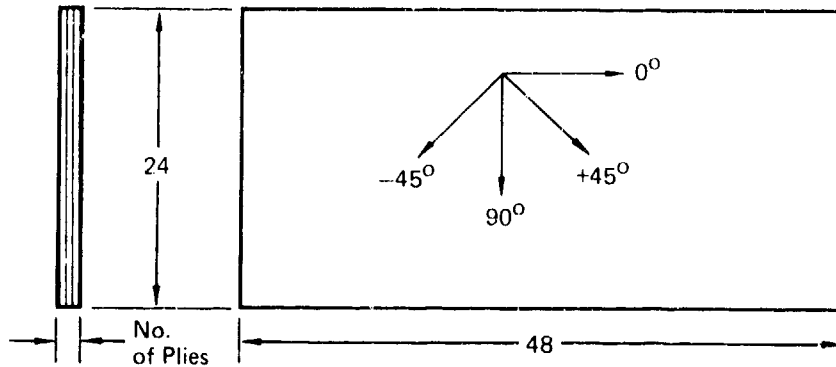

Panel No.	No. of Plies	Stacking Sequence (See Note)	Graphite/Epoxy Prepreg Material Used	
			Lot No.	Spool No.
24	20	①	1,290	8
25		②		8 (Plies 1 → 13) 12 (Plies 14 → 20)
26		③		12
27		①		12 (Plies 1 → 8) 9 (Plies 9 → 20)
28				9
29			9 (Ply 1) 1 (Plies 2 → 20)	
⑥ 30			1,290 1,010	1 (Plies 1 → 3) 5 (Plies 4 → 20)
31	21	④	1,487	1
32		⑤		1 (Plies 1 → 4) 2 (Plies 5 → 21)
33				2 (Plies 1 → 11) 3 (Plies 12 → 21)

Notes:

- ① [+45°, 0°, -45°, 0°, 90°, 0°, +45°, 0°, -45°, 0°]_S
- ② [+45°, 0°, -45°, 0°, +45°, 90°, -45°, 0°, +45°, -45°]_S
- ③ [+45°, -45°, 0°₂, 90°, 0°, +45°, -45°, 0°₂]_S
- ④ [(+45°, -45°, 0°)₂, (+45°, -45°)₂, 90°, (-45°, +45°)₂, (0°, -45°, +45°)₂]
- ⑤ [+45°, 0°, -45°, 0°, (+45°, -45°)₃, 90°, (-45°, +45°)₃, 0°, -45°, 0°, +45°]
- ⑥ Panel was fabricated so as to contain moderate porosity. Panel was not vacuum debulked during collation and a fine mist of water was sprayed between plies 5 and 6, plies 10 and 11, and plies 15 and 16 during collation procedures.

GP13-0115-200

Figure 48. Panel Configurations

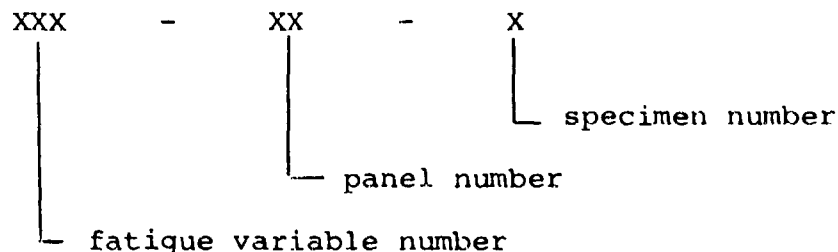

The fatigue variable number is identified in the Task 4 test matrix, Figure 46. A random selection of specimens for each test was done wherever possible.

A total of 351 specimens were fabricated for Task 4. Space was allocated in each panel for specimen duplication and material examination as necessary. Thickness, width and hole diameter measurements were recorded for each specimen after fabrication.

6. TEST PROCEDURES - Data documented for all static test specimens in Task 4 included:

- o Thickness, width and hole size measurements
- o Failure load and failure strains
- o Load vs strain plots to failure
- o Load vs deflection plots to failure
- o Weight gain of humidity exposure specimens
- o Representative photographs

Data documentation for the fatigue specimens included:

- o Thickness and width measurements
- o Hole size measurements before and after fatigue
- o Loading conditions
- o Cycles to failure
- o Hysteresis plots
- o Residual strength
- o Weight gain of humidity exposure specimens
- o Representative photographs

A double shear load block with a 3/8 inch diameter bolt was the loading fixture used for most of the fatigue test program. The baseline fatigue configuration required bolts to be untorqued.

Based on the associated static load-deflection data, load levels for the fatigue test program were chosen. Load levels for constant amplitude $R = .1$ fatigue specimens were chosen at the point of initial nonlinear behavior on the static load-deflection curve, and above and below this load level. Load levels for constant amplitude $R = -1$ and spectrum fatigue were based on $R = .1$ results.

Hysteresis curves were documented at incremental increases in total joint deflection by presetting the MTS machines to automatically interrupt cycling at predetermined amounts of total joint deflection. To obtain an accurate measurement of permanent hole elongation, documented hysteresis loops were compression-to-tension loadings to assure that the bolt was seated on the backside of the hole.

Cyclic rates were maintained within the envelope of the MTS machine to accurately sustain the required loads. In some tests, as holes elongated, cyclic rates were decreased to assure accurate performance.

The random load spectrum used in Task 4 was an "F-15 Measured-Mix Wing Spectrum-Truncated". This spectrum was generated by combining three F-15 wing baseline spectra (Air-to-air, air-to-ground, and instrumentation and navigation) into one spectrum termed "F-15 Wing Measured Mix". The Measured Mix spectrum is a cycle-by-cycle history based on F-15 measured load factor exceedances. The distribution of hours and exceedances for the air-to-air, air-to-ground, and instrumentation and navigation in the Measured Mix spectrum are given in Table 9. To obtain the "truncated" spectrum, low loads in the baseline spectrum were truncated at 55% test limit load (TLL), resulting in 5000 load cycles per thousand hours. The exceedance curve for this truncated spectrum is illustrated in Figure 49. The maximum tensile load in this spectrum was 101% TLL with a maximum compressive load of -26% TLL.

TABLE 9. DISTRIBUTION OF HOURS AND EXCEEDANCES

	MEASURED MIX	
	HOURS	EXCEEDANCES OF 60% LIMIT STRESS
AIR-TO-AIR	700	3,150
AIR-TO-GROUND	100	140
INSTRUMENTATION AND NAVIGATION	200	10
TOTAL	1,000	3,300

QP13-0115.201

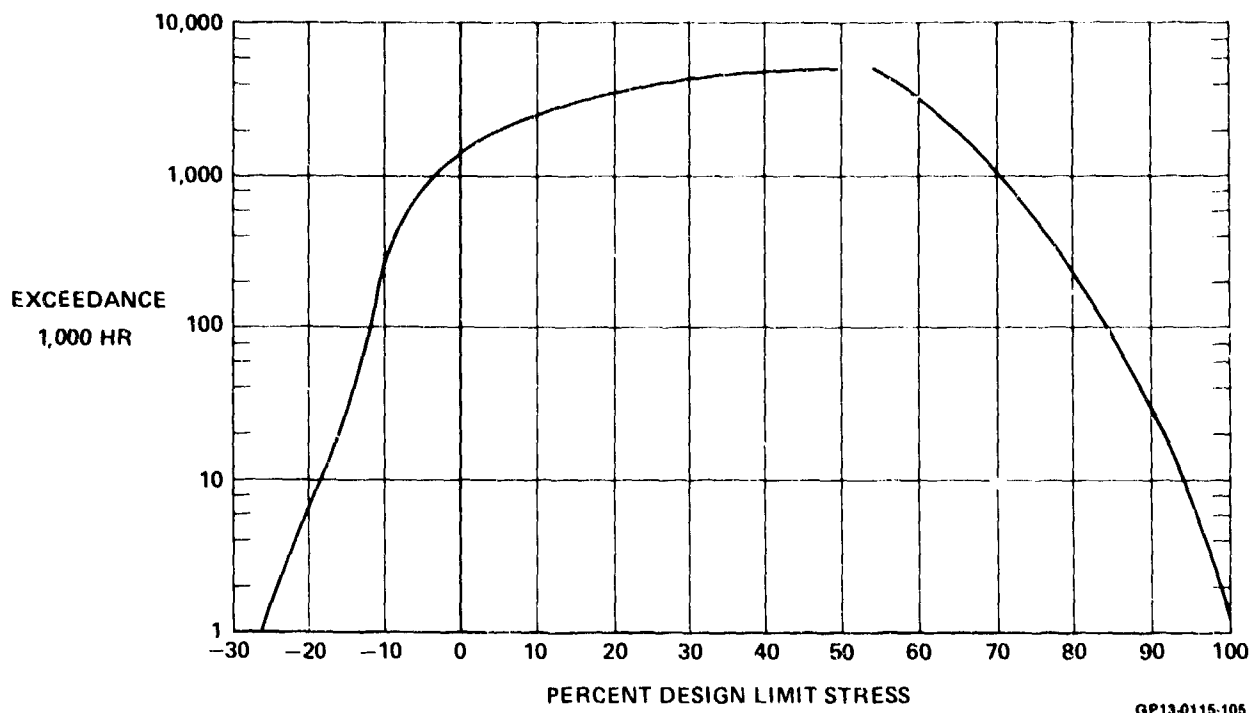

GP13-0115-105

Figure 49. Measured Mix-Truncated Spectrum

Specimens requiring moisture preconditioning were exposed to an environmental schedule which allowed specimens to obtain an equilibrium level of approximately .86 percent moisture by weight in the least amount of time. Results of the moisture preconditioning schedule used are given in Figure 50.

Twelve moisture preconditioned baseline specimens were tested at an elevated temperature of 250°F. An environmental chamber enclosed the specimens during testing to maintain temperature and humidity conditions. During fatigue loading of the twelve specimens, identical moisture preconditioned coupon specimens were simultaneously subjected to the same environment to determine moisture level changes. These coupon specimens, weighed immediately before and after the fatigue testing, resulted in negligible moisture differences. Also, twelve specimens were subjected to thermal spikes prior to testing (described in detail in Section IV.8).

Randomly selected specimens were statically tested for residual strength after completion of the fatigue evaluation.

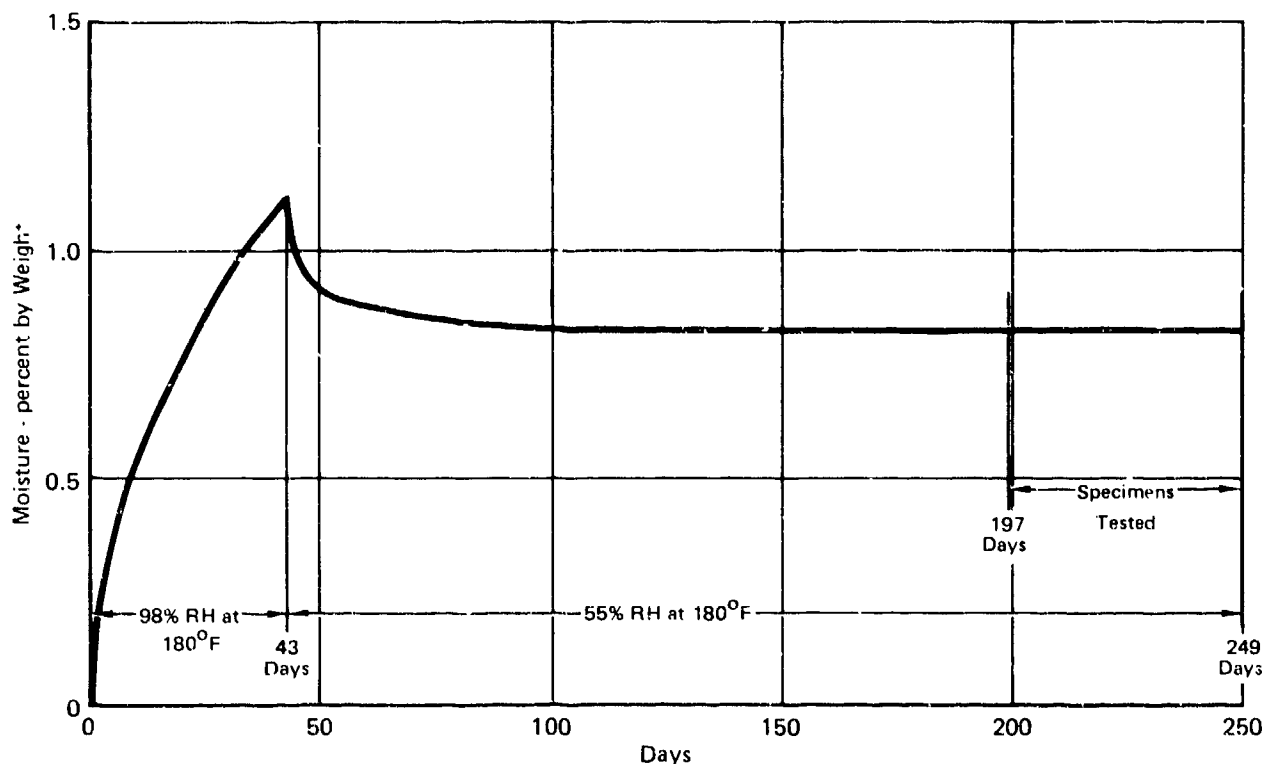

GP13-0115-202

Figure 50. Task 4 Environmental Exposure Schedule

7. TEST EQUIPMENT - Task 4 testing was accomplished with 100,000 pound capacity MTS machines. All machines were equipped with hydraulic grips and circuitry necessary to automatically shut off the machine at preselected head displacement values.

Double and single shear load blocks used in Tasks 2 and 3 were also used in Task 4. No wear was detected of the load blocks after fatigue testing was completed.

8. SPECIAL PROCEDURES - One panel was fabricated with a moderate amount of porosity by modifying panel layup and cure cycle procedures. The procedures used were identical to those used in Task 3 (Section III.8). Ultrasonic inspection was used to quantify the amount of porosity and to locate specimens within the panel to obtain moderate porosity levels within the bolt hole area.

Twelve baseline specimens were subjected to thermal spikes during environmental preconditioning. The thermal spikes were representative of measured F-15 flight test data for a supersonic dash. The thermal spike procedure used is outlined in Figure 51. Ideally, heat-up and cool-down rates of 1°F per second were required. Specimens were weighed immediately before and after thermal spiking to determine moisture absorption characteristic changes. These weight measurements indicated no moisture loss during the thermal spike exposure. A series of ten thermal spikes were performed allowing two days of environmental exposure (180°F - 55% RH) between spikes.

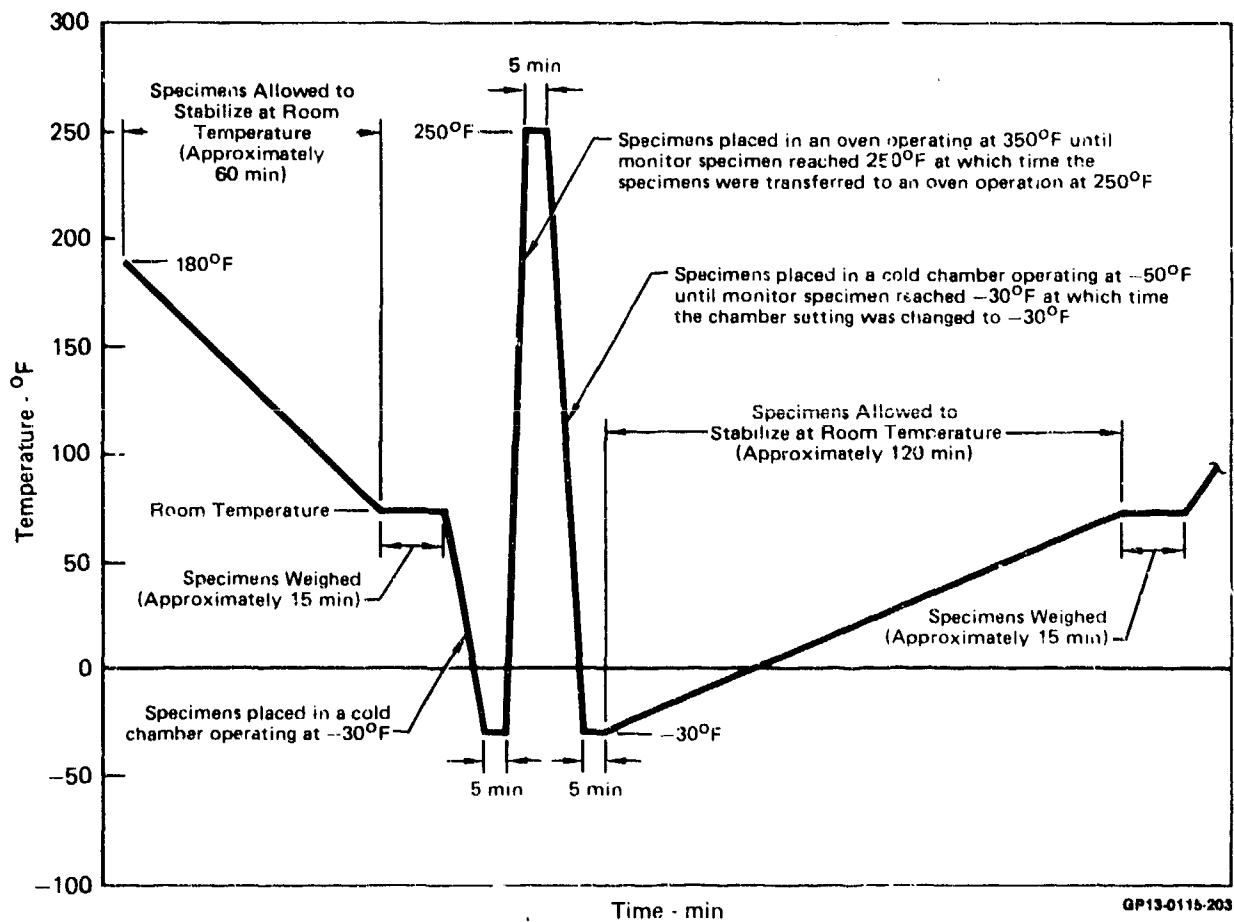

Figure 51. Thermal Spike Cycle

9. TEST DATA - Results of all test data obtained in Task 4 are presented in this section. Test results are divided in three parts; static tests, constant amplitude fatigue and spectrum fatigue tests.

a. Static Tests - Tension strength test data used to determine fatigue load levels are presented in Table 10. Associated specimen and test setup configurations are shown in Figure 52. Representative photographs of specimen failures are shown in Figures 53 and 54.

b. Constant Amplitude Fatigue - Results of the constant amplitude fatigue tests performed in Task 4 are summarized in Table 11. Corresponding specimen and test set-up configurations for these tests are included in Figure 52. Photographs of representative failed specimens are shown in Figures 55 through 58.

c. Spectrum Fatigue - Results of specimens subjected to spectrum fatigue are presented in Table 12. Test set-up configurations for spectrum fatigue are shown in Figure 52. Representative specimen failures are shown in Figure 59.

TABLE 10. STATIC TENSION STRENGTH TEST DATA

Specimen Number	Specimen and Test Setup Configurations (See Figures)	Percent 0°/45°/90° Plies	Test Variable	Moisture Content (% by wt)	Test Temp	Fastener Torque (in.-lb)	Thickness (in.)	Width (in.)	Hole Dia (in.)	Failing Load (lb)		Strain at Failure (µin./in.)		Mode of Failure
										Individual	Average	Individual	Average	
1-24-41	47A, 52A	50/40/10		N/A	RT	0 + Gap	0.2092	2.254	0.3748	7,380	7,533	1,460	1,401	④
1-27-23							0.2184	2.255	0.3746	7,500	S = 172	1,352	S = 55	
1-27-31							0.2212	2.255	0.3747	7,720	1,390			
1-24-20							0.2274	2.255	0.3748	7,150	1,458	1,429		
1-27-30							0.2258	2.255	0.3745	7,300	1,410	S = 25		
1-24-21							0.2298	2.253	0.3748	7,300	1,420			
1-27-5							0.2149	2.255	0.3747	4,820	858	786		
1-27-8							0.2058	2.253	0.3746	3,475	660	S = 109		
1-27-14							0.2276	2.255	0.3745	4,340	840			
1-24-24							0.2249	2.255	0.3748	7,000	1,400	1,387		
1-24-26							0.2259	2.255	0.3747	7,130	1,380	S = 12		
1-27-18							0.2270	2.254	0.3748	6,940	1,380			
1-25-10							0.2297	2.253	0.3746	1,500	1,925	1,908		
1-25-16							0.2250	2.253	0.3746	7,500	1,900	S = 14		
1-25-18							0.2278	2.253	0.3748	7,430	1,900			
1-32-35	0.2440	2.251	0.3754	8,050	2,670	2,645								
1-32-43	0.2381	2.251	0.3749	7,750	7,850	2,665								
1-32-41	0.2300	2.250	0.3749	7,750	S = 173	S = 39								
2-26-10	0.2313	2.253	0.3745	6,850	7,233	1,333								
2-26-16	0.2227	2.253	0.3747	7,500	1,365	S = 87								
2-26-18	0.2289	2.253	0.3747	7,350	1,400									
2-31-10	0.2462	2.251	0.3752	6,000	2,665	2,718								
2-31-16	0.2365	2.250	0.3749	7,800	8,067	2,575								
2-31-18	0.2438	2.249	0.3750	8,400	S = 306	S = 176								
3-28-9	0.2205	2.254	0.3753	9,060	9,347	1,765								
3-28-35	0.2299	2.255	0.3745	9,680	S = 313	S = 66								
3-24-10	0.2290	2.253	0.3745	9,300	1,755									
3-32-4	0.2318	2.251	0.3749	12,530	4,140	4,163								
3-33-33	0.2439	2.251	0.3753	12,640	12,567	4,205								
3-33-31	0.2418	2.251	0.3750	12,530	S = 64	4,145								

⑤
⑤
⑤

GP124615-204

TABLE 10. (Continued) STATIC TENSION STRENGTH TEST DATA

Specimen Number	Specimen and Test Setup Configurations (See Figures)	Percent 0°/45°/90° Plies	Test Variable	Moisture Content (% by wt)	Test Temp	Fastener Torque (in.-lb)	Thickness (in.)	Width (in.)	Hole Dia (in.)	Fading Load (lb)		Strain at Failure (μin./in.)		Mode of Failure
										Individual	Average	Individual	Average	
4-29-14	47B, 52A	50/40/10	Geometry e/d = 3 w/d = 4				0.2312	1.507	0.3745	7.620	7.440	2.040	2.210	④
4-29-19							0.2145	1.507	0.3745	7.080	S = 312	2.035	S = 299	
4-29-21							0.2209	1.506	0.3746	7.620	2.555			
4-29-29	47C, 52A	50/40/10	Geometry e/d = 4 w/d = 4				0.2289	1.507	0.3745	7.470	7.610	2.095	2.163	②
4-29-16							0.2236	1.506	0.3745	7.620	2.185	S = 60		
4-29-11							0.2171	1.506	0.3748	7.740	2.210			
4-33-10	47B, 52A	19/76/5	Geometry e/d = 3 w/d = 4				0.2450	1.500	0.3746	9.225	7.983	4.800	3.963	③
4-33-13							0.2370	1.500	0.3748	7.275	3.480	S = 727		
4-33-14							0.2463	1.496	0.3750	7.450	3.610			
4-33-22	47D, 52A	50/40/10	Geometry e/d = 3 w/d = 3				0.2437	1.124	0.3752	6.420	6.353	4.065	3.900	③
4-33-25							0.2474	1.124	0.3751	6.280	3.805	S = 100		
4-33-26							0.2430	1.124	0.3752	5.360	3.890			
5-24-29	47E, 52C		Fastener Fit		RT		0.2274	2.250	0.3693	8.100	8.100	1.730	1.576	①
5-24-48							0.2124	2.254	0.3693	7.350	1.548	S = 142		
5-28-34							0.2278	2.254	0.3710	8.850	1.450			
6-28-7	47A, 52C	50/40/10	Single-Shear Protruding Head				0.2079	2.294	0.3748	8.950	9.250	1.770	1.830	②
6-27-37							0.2306	2.25	0.3747	9.100	1.830	S = 60		
6-27-35							0.2298	2.253	0.3748	9.700	1.890			
6-24-35	47F, 52E	50/40/10	Single-Shear Counter-Sunk Head				0.2294	2.253	0.3748C	8.050	8.200	1.395	1.450	②
6-28-25							0.2230	2.254	0.3746C	8.400	1.500	S = 53		
6-27-43							0.2148	2.254	0.3748C	8.150	1.455			
7-30-1	47A, 52A		Porosity				0.2254	2.250	0.3757	7.860	7.807	1.465	1.468	①
7-30-8							0.7321	2.250	0.3757	7.460	1.395	S = 75		
7-30-15							0.2271	2.250	0.3747	8.100	1.545			

GP130115-205

TABLE 10. (Concluded) STATIC TENSION STRENGTH TEST DATA

Notes:

- ① following hole diameter dimension indicates that hole was countersunk
- e/d = 3 for all specimens except as noted in the test variable column
- w/d = 6 for all specimens except as noted in the test variable column
- 20 ply thickness for all specimens with 50/40/10 or 30/60/10 layups. 21 ply thickness for all specimens with 19/76/5 layup
- Specimens were thermal spiked prior to testing
- Mode of failure legend: ② - ① implies a combination tension-cleavage-shearout mode of failure

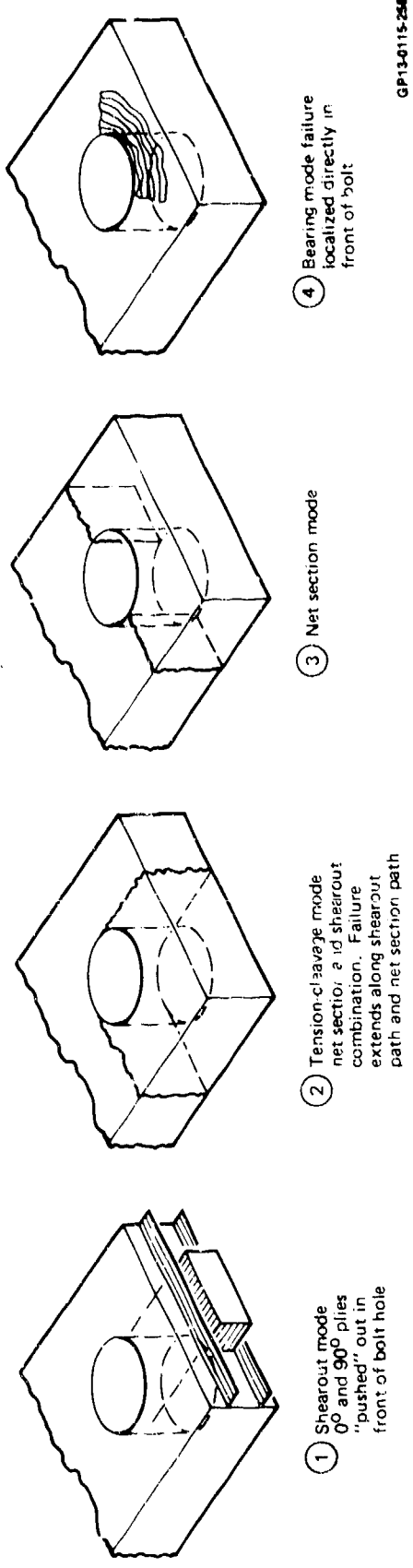

GP13-0115-254

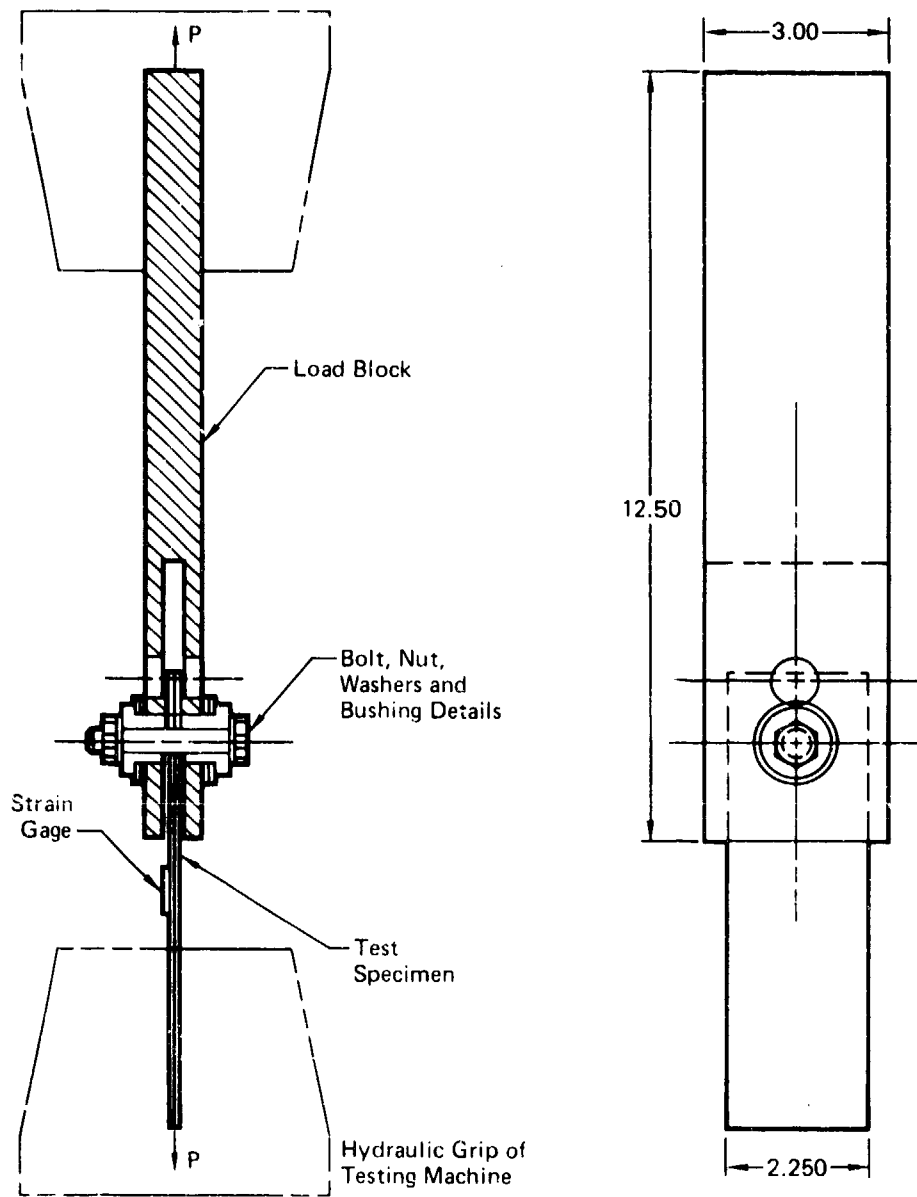

GP13-0115-206

Figure 52. Task 4 Test Setups

13/16 I.D. x 1-1/4 O.D. Flat Washers as Required to Keep Face of Bushing Flush with Surface of Load Block (Typical 2 Places)

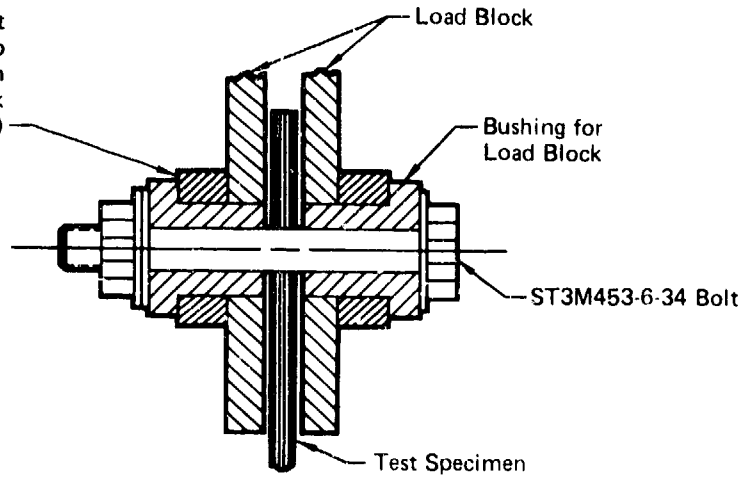

Test Configuration 52A

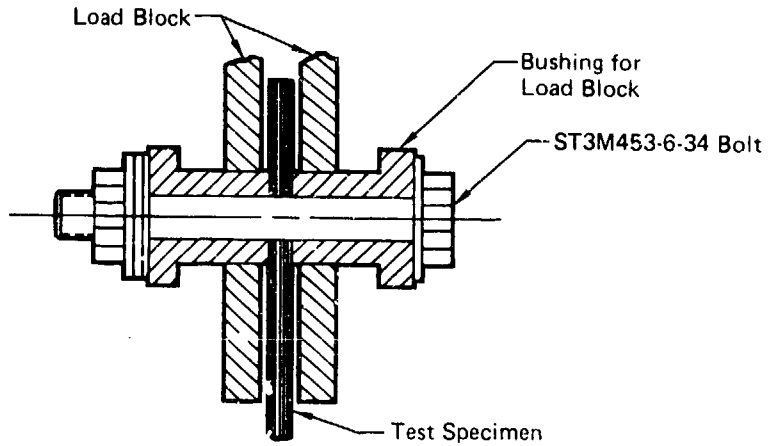

Test Configuration 52B

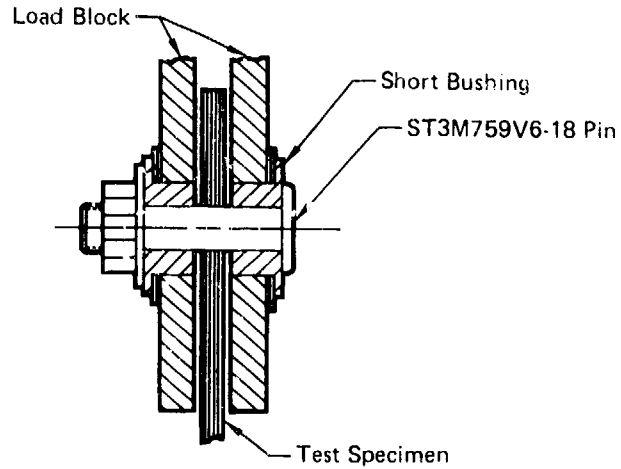

Test Configuration 52C

GP13-0115-207

Figure 52. Task 4 Test Setups

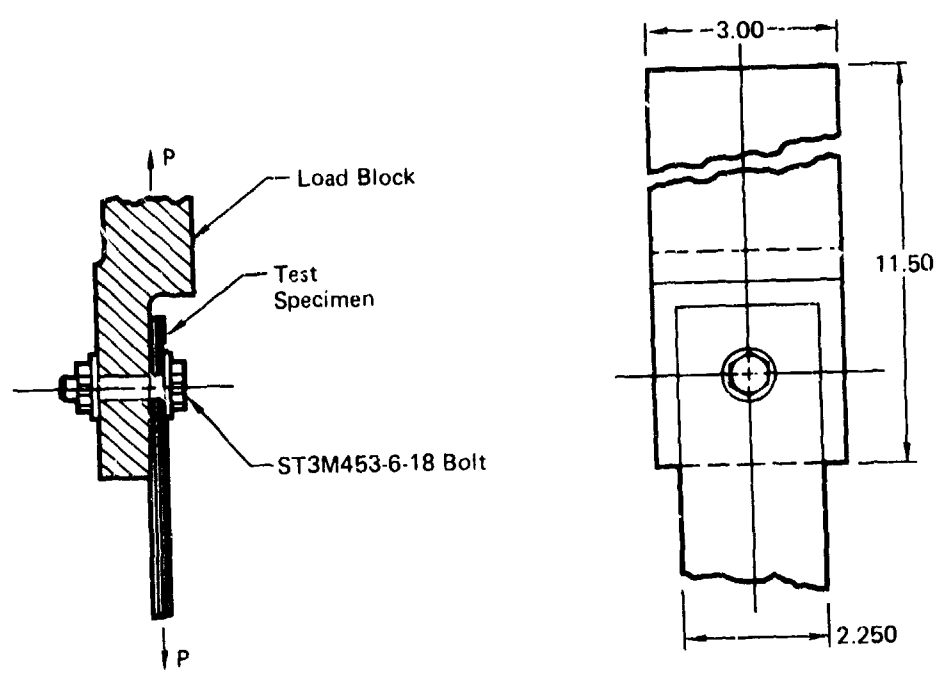

Test Configuration 52D

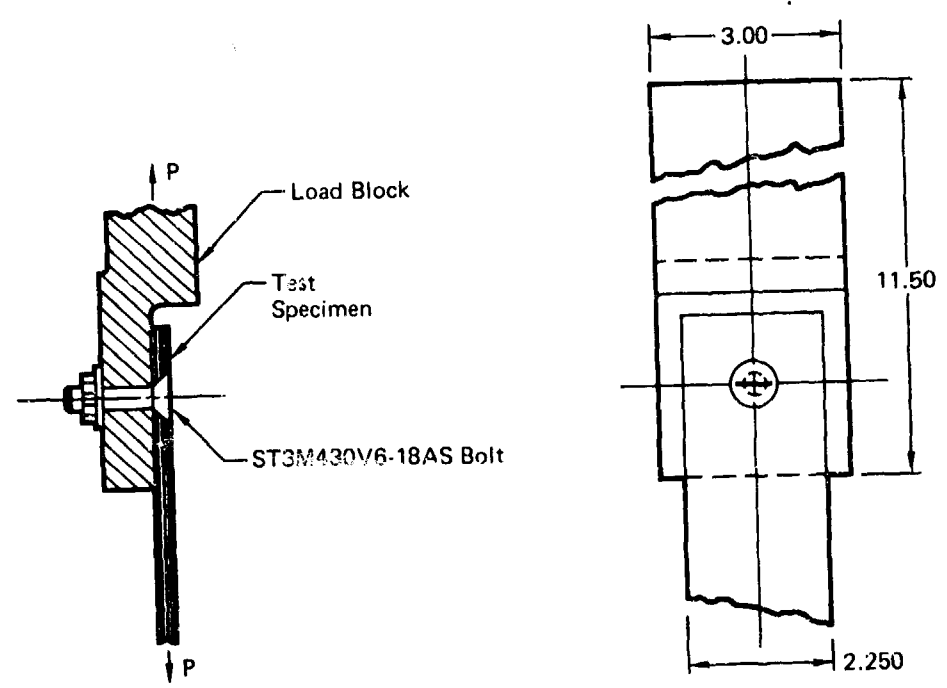

Test Configuration 52E

QP13-0115-208

Figure 52. (Continued) Task 4 Test Setups

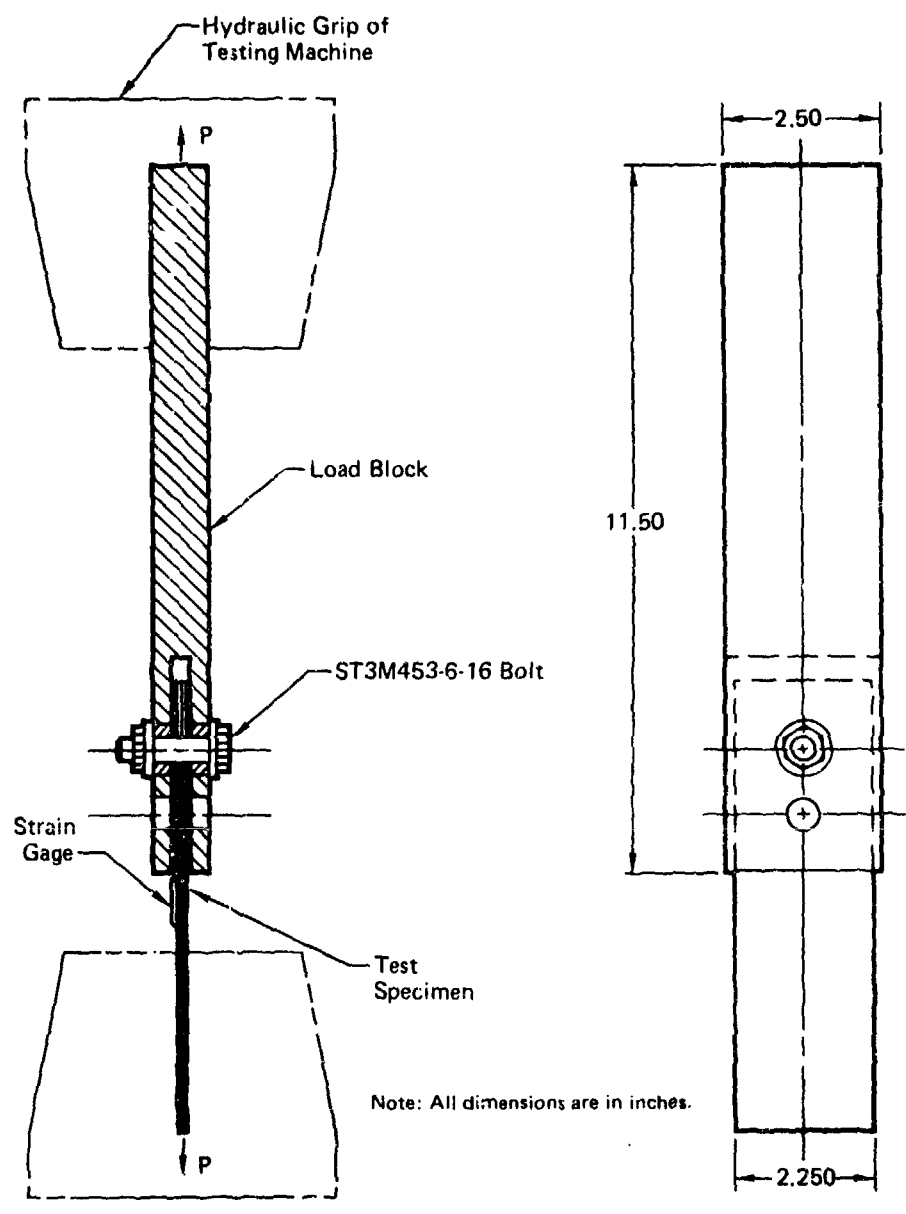

Test Configuration 52F

GP13-0115-200

Figure 52. (Concluded) Task 4 Test Setups

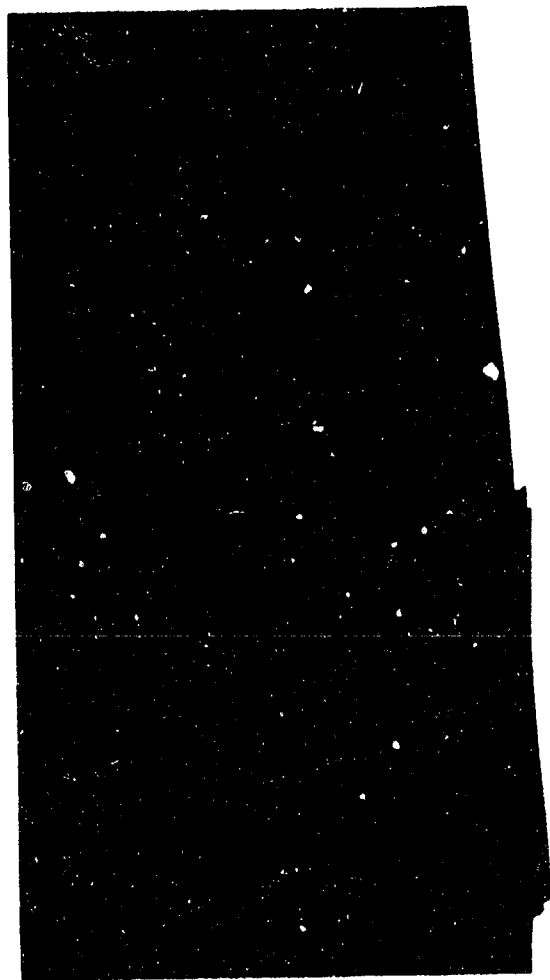

Net Section



Tension - Cleavage

QP13-0115-256

Figure 53. Static Net Section and Tension - Cleavage Modes c' Failure



Bearing



Bearing

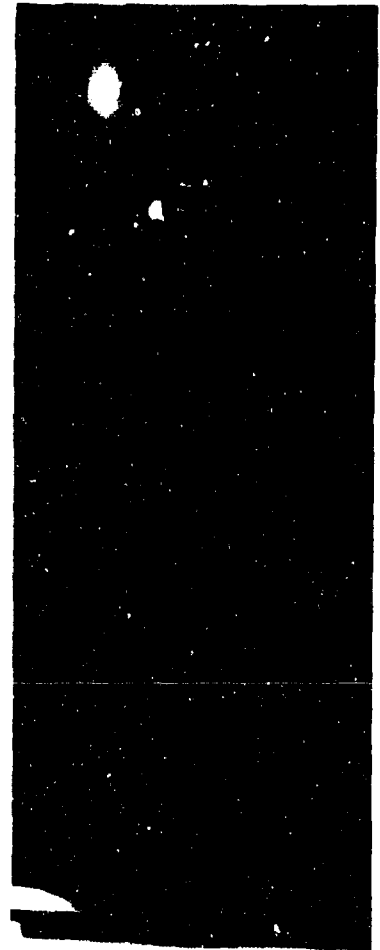

Shearout

GP13-0115-2F5

Figure 54. Static Bearing and Shearout Modes of Failure

TABLE 11. CONSTANT AMPLITUDE FATIGUE TEST DATA

Specimen Number	Specimen and Test Setup Configurations (See Figures)	Percent 0°/45°/90° Plies	Test Variable	Fastener Torque (in.-lb)	Thickness (in.)	Width (in.)	Hole Dia (in.)	Stress Ratio	Load (lb)		Cyclic Rate (Hz)	Cycles to Failure	Total Head Deflection (in.)	Hole Dia (in.)	Residual Failing Load (lb)	Mode of Failure
									Max	Min						
1-28-22	47A, 52A		Baseline	0 + Gap	0.2255	2.255	0.3748	0.1	5,400	540	V	65,000 (H)	0.0312	0.387	-	7
1-24-6					0.2227	2.253	0.3749		6,400	640	5	920 (H)	0.0358	-	8,975	2
1-24-22					0.2308	2.254	0.3750		5,500	550	1 and 5	371 (H)	0.0468	-	8,820	4
1-28-10					0.2233	2.254	0.3748		5,000	500	5	320,000 (H)	0.0454	-	8,540	1
1-24-36					0.2293	2.254	0.3748		5,000	500	5	575,000 (H)	0.0418	-	8,540	1
1-27-39					0.2188	2.255	0.3747		5,000	500	5	1,565,000 (N)	0.0450	-	9,140	1
1-28-14					0.2256	2.254	0.3762		5,000	500	5	2 (M)	0.0736	-	-	5
1-28-36					0.2285	2.254	0.3748		5,000	500	5	22,950 (H)	0.0622	-	-	6
1-28-4					0.2218	2.254	0.3745		5,000	500	5	12,700 (H)	0.0608	-	8,940	5 - 1
1-27-2					0.2243	2.255	0.3748		5,000	500	5	6,493 (H)	0.0822	-	8,520	5 - 2
1-28-31	47A, 52F	50/40/10	Baseline	0 + Gap	0.2255	2.255	0.3746	-1.0	5,500	-5,500	2	2,690 (H)	0.0790	0.427	-	5
1-24-19					0.2250	2.255	0.3745		4,500	-4,500	V	9,730 (H)	0.0808	-	-	6
1-27-15					0.2312	2.254	0.3749		6,400	640	5	144,900 (H)	0.0848	-	8,430	5 - 1
1-27-15					0.2239	2.255	0.3747		6,400	640	5	129,000 (H)	0.0824	-	11,420	5 - 1
1-24-38					0.2302	2.254	0.3751		6,400	640	5	3,130 (H)	0.0420	-	-	2
1-28-33					0.2246	2.255	0.3749		6,400	640	5	420 (H)	0.0522	-	-	4
1-27-38					0.2255	2.255	0.3746		6,400	640	5	950 (H)	0.0414	-	10,460	2
1-24-23					0.2306	2.255	0.3748		6,400	640	5	18,820 (H)	0.0458	-	10,820	2
1-24-31					0.2305	2.255	0.3746		6,400	640	5	111,230 (H)	0.0394	-	-	4
1-25-5					0.2317	2.254	0.3747		6,400	640	5	1,000,000 (N)	0.0417	-	5,880	1
1-25-27	47A, 52A	30/60/10	Baseline	0 + Gap	0.2162	2.253	0.3745	0.1	5,150	515	5 and 15	961,000 (H)	0.0610	0.414	-	4
1-25-2					0.2238	2.254	0.3748		5,000	-5,000	5	1,000,000 (N)	0.0381	-	-	5
1-25-25					0.2298	2.254	0.3746		5,000	-5,000	5	10,120 (H)	0.0610	-	10,140	5 - 2
1-25-9					0.2248	2.255	0.3748		5,000	-5,000	5	4,470 (H)	0.0612	-	10,140	5 - 2
1-25-20					0.2249	2.255	0.3746		5,000	-5,000	5	11,860 (H)	0.0600	-	-	5
1-25-30					0.2269	2.254	0.3748		5,000	-5,000	5	11,860 (H)	0.0600	-	-	5
1-25-23					0.2191	2.254	0.3746		5,000	-5,000	5	11,860 (H)	0.0600	-	-	5
1-25-12					0.2325	2.255	0.3749		5,000	-5,000	5	11,860 (H)	0.0600	-	-	5
1-25-25					0.2258	2.255	0.3748		5,000	-5,000	5	11,860 (H)	0.0600	-	-	5
1-25-15					0.2217	2.255	0.3747		5,000	-5,000	5	11,860 (H)	0.0600	-	-	5
1-25-6	0.2317	2.255	0.3747	5,000	-5,000	5	11,860 (H)	0.0600	-	-	5					

GP13-6115-38

TABLE 11. (Continued) CONSTANT AMPLITUDE FATIGUE TEST DATA

Specimen Number	Specimen and Test Setup Configurations (See Figures)	Percent 0°/45°/90° Piles	Test Variable	Fastener Torque (in.-lb)	Thickness (in.)	Width (in.)	Hole Dia (in.)	Stress Ratio	Load (lb)		Cyclic Rate (Hz)	Cycles to Failure	Total Head Deflection (in.)	Hole Dia (in.)	Residual Failing Load (lb)	Mode of Failure
									Max	Min						
1-25-7					0.2257	2.255	0.3748				5	2,720 (H)	0.0800	0.421	-	7
1-25-13					0.2330	2.255	0.3747		5,400	-5,400	2	4,100 (H)	0.0798	0.424	10,920	5-2
1-25-14	47A, 52F	30/60/10			0.2305	2.255	0.3750	-1.0				6,790 (H)	0.1336	0.523	-	5
1-25-1					0.2203	2.254	0.3748				V	36,630 (H)	0.0812	0.438	9,600	5-1
1-25-28					0.2210	2.254	0.3748		4,400	-4,400		41,900 (H)	0.0972	0.449	-	5
1-25-22					0.2292	2.255	0.3746					45,800 (H)	0.0796	0.435	-	6
1-32-19					0.2422	2.251	0.3751				5	118,550 (H)	0.0403	-	11,420	2
1-32-32					0.2315	2.251	0.3746		6,200	620	10	3,530 (H)	0.0404	-	11,260	2
1-32-36					0.2410	2.238	0.3749					23,110 (H)	0.0396	0.387	-	4
1-32-9					0.2296	2.251	0.3750				5	205,020 (H)	0.0394	-	10,560	2
1-32-10	47A, 52A		Baseline		0.2410	2.251	0.3757	0.1	5,100	510	5 and 10	318,600 (H)	0.0280	-	11,420	3
1-33-6					0.2442	2.249	0.3755				10	1,000,000 (N)	0.0200	0.376	-	4
1-32-3					0.2391	2.235	0.3749				5 and 15	277,330 (H)	0.0612	0.396	-	4
1-33-1					0.2422	2.249	0.3759		7,000	700		210,450 (H)	0.0660	0.402	-	2
1-32-17				0 + Gap	0.2283	2.251	0.3759					1,100 (H)	0.0596	0.399	9,900	2
1-32-40					0.2352	2.232	0.3750					20,400 (H)	0.0618	0.409	-	6
1-33-2		19/76/5			0.2445	2.249	0.3746		4,500	-4,500		30,200 (H)	0.0627	0.409	11,680	5-2
1-33-36					0.2450	2.250	0.3751				5	25,210 (H)	0.0628	0.413	-	6
1-32-46					0.2450	2.245	0.3760	-1.0				6,000 (H)	0.0614	0.401	-	6
1-32-23	47A, 52F				0.2413	2.250	0.3754		5,100	-5,100		5,450 (H)	0.0656	0.410	-	6
1-33-34					0.2451	2.250	0.3752					8,520 (H)	0.0624	0.405	10,480	5-2
1-32-29					0.2442	2.236	0.3749					493,040 (H)	0.0800	0.428	10,700	5-2
1-32-18					0.2384	2.251	0.3748		3,800	-3,800	V	423,410 (H)	0.0828	0.437	-	6
1-33-35					0.2441	2.250	0.3751					292,850 (H)	0.0808	0.427	-	6
2-26-5					0.2292	2.253	0.3747					601 (H)	0.0470	0.394	-	4
2-26-27					0.2194	2.253	0.3745		6,200	620	5	301 (H)	0.0326	-	8,540	1
2-26-2					0.2216	2.255	0.3746	0.1				301 (H)	0.0358	-	8,920	1
2-26-25					0.2331	2.253	0.3745					24,410 (H)	0.0616	0.414	-	4
2-26-9					0.2299	2.254	0.3745		5,500	550	10	11,660 (H)	0.0776	-	8,780	4
2-26-20					0.2248	2.253	0.3745					7,950 (H)	0.0670	-	9,040	1

GP-134116-211

TABLE 11. (Continued) CONSTANT AMPLITUDE FATIGUE TEST DATA

Specimen Number	Specimen and Test Setup Configurations (See Figures)	Percent 0°/45°/90° Plys	Test Variable	Fastener Torque (in.-lb)	Thickness (in.)	Width (in.)	Hole Dia (in.)	Stress Ratio	Load (lb)		Cyclic Rate (Hz)	Cycles to Failure	Total Head Deflection (in.)	Hole Dia (in.)	Residual Fatigue Load (lb)	Mode of Failure			
									Max	Min									
2-26-30	47A, 52A				0.2343	2.252	0.3747	0.1	5,000	500	10	1,488,000 (N)	0.0229	0.381	-	⑦			
2-26-23					0.2160	2.253	0.3746										0.288	8,040	①
2-26-12					0.2336	2.251	0.3748										0.267	9,280	①
2-26-29	47A, 52F	50/40/10 Special Panel No. 26			0.2311	2.253	0.3748	-1.0	5,000	-5,000	5	17,630 (H)	0.0620	0.408	-	⑥			
2-26-15					0.2091	2.255	0.3747										0.0612	7,940	①
2-26-6					0.2291	2.254	0.3747										0.0636	-	⑥
2-26-7					0.2249	2.254	0.3746										0.0818	-	⑤
2-26-13					0.2336	2.253	0.3746										-	-	⑥
2-26-14					0.2260	2.254	0.3748										0.0820	9,000	①
2-26-1	0.2132	2.253	0.3747	0.0812	-	⑤													
2-26-28	0.2275	2.253	0.3745	0.0796	8,080	⑤ · ①													
2-26-22	0.2293	2.253	0.3746	0.0830	-	⑥													
2-31-5	47A, 52A		Stacking Sequence	0 + Gap	0.2393	2.251	0.3756	0.1	6,500	610	5	1,070 (H)	0.0396	-	12,140	②			
2-31-27					0.2280	2.250	0.3749										0.0416	10,800	②
2-31-2					0.2315	2.251	0.3754										0.0402	11,000	②
2-31-25					0.2426	2.250	0.3749										0.0396	12,100	②
2-31-9					0.2360	2.251	0.3757										0.0448	10,900	②
2-31-20					0.2380	2.250	0.3754										0.0396	-	④
2-31-30					0.2454	2.250	0.3749										0.0462	-	④
2-31-23					0.2246	2.250	0.3756										0.0747	-	④
2-31-12					0.2432	2.250	0.3746										0.0561	11,000	②
2-31-29					0.2417	2.250	0.3752										0.0600	-	⑤
2-31-15	0.2270	2.250	0.3748	0.0666	10,380	⑤ · ②													
2-31-6	0.2370	2.250	0.3748	0.0608	-	⑤													
2-31-7	0.2327	2.251	0.3748	0.0616	-	⑤													
2-31-13	47A, 52A	19/75/5 Special Panel No. 31			0.2411	2.251	0.3749	-1.0	5,600	-5,600	5	3,490 (H)	0.0604	0.407	11,360	⑤ · ②			
2-31-14					0.2347	2.251	0.3750										0.0610	-	⑤
2-31-1					0.2256	2.251	0.3748										0.0824	-	⑤
2-31-28					0.2380	2.251	0.3750										0.0820	-	⑤
2-31-22					0.2423	2.250	0.3756										0.0806	11,380	⑤ · ②

GP13-0116-212

TABLE 11. (Continued) CONSTANT AMPLITUDE FATIGUE TEST DATA

Specimen Number	Specimen and Test Setup Configurations (See Figures)	Percent $0^\circ/45^\circ/90^\circ$ Piles	Test Variable	Fastener Torque (in.-lb)	Thickness (in.)	Width (in.)	Hole Dia (in.)	Stress Ratio	Load (lb)		Cyclic Rate (Hz)	Cycles to Failure	Total Head Deflection (in.)	Hole Dia (in.)	Residual Failing Load (lb)	Mode of Failure																																																																																				
									Max	Min																																																																																										
3-24-37	4/A, 52B	50/40/10	Torque Up	180	0.2298	2.253	0.3748	0.1	7,900	790	5 and 10	415,270 (F)	-	-	-	①																																																																																				
3-28-15					0.2190	2.254	0.3752										0.2263	2.253	0.3745	0.2264	2.254	0.3747	0.2283	2.254	0.3746	0.2209	2.254	0.3746	0.2301	2.254	0.3746	0.2296	2.252	0.3748	0.2102	2.252	0.3745	0.2280	2.252	0.3746	0.2190	2.254	0.3745	0.2276	2.254	0.3745	0.2203	2.254	0.3745	0.2230	2.252	0.3749	0.2259	2.254	0.3747	0.2155	2.254	0.3745	0.2274	2.254	0.3747	0.2199	2.254	0.3745	0.2417	2.251	0.3752	0.2385	2.250	0.3746	0.2392	2.250	0.3751	0.2438	2.250	0.3750	0.2394	2.250	0.3757	0.2413	2.251	0.3746	0.2343	2.251	0.3756	0.2415	2.242	0.3753	0.2387	2.251	0.3752	0.2384	2.251	0.3749	0.2337	2.250	0.3750	0.2426	2.250	0.3755
3-27-21																									480,270 (F)				②																																																																							
3-24-46																									1,000,000 (N)	0.0164	10,580		②																																																																							
3-27-10																						6,700	670		1,000,000 (N)	0.0166	11,220		④																																																																							
3-28-6																									1,000,000 (N)	0.0168			④																																																																							
3-28-27																						8,800	880		207,130 (F)				①																																																																							
3-24-14																									59,100 (F)				①																																																																							
3-28-8																							5		2,530 (F)				⑤-①																																																																							
3-24-45																									188,640 (H)	0.9550			⑤-①																																																																							
3-28-2																						6,700	-6,700		145,770 (F)				⑤-②																																																																							
3-28-18																									92,000 (H)	0.0800	9,800		⑤-②																																																																							
3-27-17																									12,140 (H)	0.0552			②																																																																							
3-24-5																						7,400	-7,400	V	63,560 (H)	0.0800	9,960		⑤-②																																																																							
3-24-34																									57,510 (F)				⑤-①																																																																							
3-27-40																									21,340 (H)	0.0736			⑤-①																																																																							
3-24-12																						8,200	-8,200		16,230 (F)				②																																																																							
3-28-17																									23,280 (H)	0.0492			②																																																																							
3-32-5																									850,200 (F)				②																																																																							
3-32-34																						8,800	880	5 and 10	406,990 (F)				④																																																																							
3-32-31												431,440 (F)				④																																																																																				
3-32-13												22,750 (H)	0.0529	0.384		④																																																																																				
3-32-44									10,000	1,000	5	9,840 (H)	0.0494	12,580		②																																																																																				
3-32-6		19/76/5										9,310 (H)	0.0496	0.382		④																																																																																				
3-32-25												3 (M)				③																																																																																				
3-32-39												12,710 (F)				②																																																																																				
3-32-15												16,250 (F)	0.0480			②																																																																																				
3-32-7												6,980 (H)	0.0800	0.434		⑤																																																																																				
3-32-2									8,800	-8,800	2	3,840 (H)	0.0792	0.395		⑤-③																																																																																				
3-32-27												4,550 (H)	0.0800	0.397		⑤-③																																																																																				

GPI-30115-213

TABLE 11. (Continued) CONSTANT AMPLITUDE FATIGUE TEST DATA

Specimen Number	Specimen and Test Setup Configurations (See Figures)	Percent 0°/45°/90° Plies	Test Variable	Fastener Torque (in.-lb)	Thickness (in.)	Width (in.)	Hole Dia (in.)	Stress Ratio	Load (lb)		Cyclic Rate (Hz)	Cycles to Failure	Total Head Deflection (in.)	Hole Dia (in.)	Residual Failing Load (lb)	Mode of Failure
									Max	Min						
3-32-45					0.2455	2.234	0.3749					30,130 (H)	0.0816	0.437	-	7
3-32-48					0.2308	2.236	0.3760		7,400	-7,400		29,820 (H)	0.0840	0.434	12,940	5-2
3-33-37	47A, 52B	19/76/5	Torque Up	180	0.2332	2.259	0.3752	-1.0			V	27,510 (H)	0.0800	0.400	-	5
3-32-21					0.2438	2.225	0.3753					116,160 (H)	0.0800	0.460	12,940	6-3
3-32-47					0.2390	2.244	0.3758		6,600	-6,600		86,700 (H)	0.0800	0.486	-	6
3-33-4					0.2448	2.249	0.3749					109,280 (H)	0.0826	0.408	-	6
4-29-10					0.2313	1.505	0.3745		6,300	630	5	750 (H)	0.0540	-	9,700	2
4-29-28					0.2277	1.505	0.3746					100 (H)	0.0464	-	9,500	
4-29-8					0.2320	1.504	0.3745					200 (H)	0.0410	0.388	-	4
4-29-26					0.2267	1.505	0.3745	0.1	6,000	600	10	3,370 (F)	-	0.412	-	
4-29-13	47B, 52A		Geometry e/d = 3 w/d = 4		0.2220	1.504	0.3745					2,620 (H)	0.0400	-	8,960	1
4-29-22					0.2173	1.504	0.3745					1,139 (H)	0.0424	-	8,880	4
4-29-30					0.2274	1.506	0.3745					23,420 (H)	0.0412	0.392	-	1-2
4-29-25					0.2278	1.505	0.3745		5,700	570	5 and 15	25,320 (H)	0.0399	0.392	8,420	1-2
4-29-16		50/40/10			0.2284	1.505	0.3745					20,730 (H)	0.0408	0.393	-	4
4-29-12					0.2304	1.504	0.3745					270 (M)	0.0510	0.401	-	4
4-29-17					0.2188	1.505	0.3747		6,500	650	1	165 (M)	0.0418	-	9,220	1
4-29-7				0 + Gap	0.2268	1.504	0.3745					133 (M)	0.0544	-	11,320	2
4-29-20					0.2151	1.504	0.3748					5,190 (H)	0.0402	-	9,980	1
4-29-23	47C, 52A		Geometry e/d = 4 w/d = 4		0.2246	1.505	0.3748	0.1	5,600	560	10	212,000 (H)	0.0392	-	10,440	2
4-29-24					0.2247	1.504	0.3747					123,680 (H)	0.0380	0.389	-	4
4-29-9					0.2267	1.504	0.3746					5,300 (H)	0.0400	0.391	-	4
4-29-15					0.2247	1.504	0.3748		6,100	610	5	6,680 (H)	0.0400	0.391	9,575	1
4-29-27					0.2278	1.504	0.3746					13,910 (H)	0.0418	0.393	-	4
4-33-8					0.2444	1.483	0.3750					311,820 (H)	0.0398	-	8,900	3
4-33-17					0.2357	1.500	0.3751		5,600	560	5 and 10	22,610 (H)	0.0414	-	9,320	3
4-33-7					0.2446	1.499	0.3756	0.1				479,450 (H)	0.0396	0.385	-	4
4-33-16	47B, 52A	19/76/5	Geometry e/d = 3 w/d = 4		0.2387	1.496	0.3752				10	368,950 (H)	0.0395	-	8,660	3
4-33-18					0.2336	1.497	0.3752		4,800	480		245,110 (H)	0.0394	-	9,520	3
4-23-11					0.2429	1.500	0.3753					333,730 (H)	0.0390	0.388	-	4

GP13-0115-226

TABLE 11. (Continued) CONSTANT AMPLITUDE FATIGUE TEST DATA

Specimen Number	Specimen and Test Setup Configurations (See Figures)	Percent $0^{\circ}/45^{\circ}/90^{\circ}$ Pliers	Test Variable	Fastener Torque (in.-lb)	Thickness (in.)	Width (in.)	Hole Dis (in.)	Stress Ratio	Load (lb)		Cyclic Rate (Hz)	Cycles to Failure	Total Head Deflection (in.)	Hole Dis (in.)	Residual Failing Load (lb)	Mode of Failure			
									Max	Min									
4-33-12	478, 52A		Geometry e/d = 3 w/d = 4		0.2434	1.495	0.3759	0.1	5,900	590	5 and 10	241,410 (H)	0.0500	-	9,150	7			
4-33-9					0.2434	1.496	0.3753		3,000	334,060 (H)							0.0504	6,300	
4-33-15					0.2398	1.500	0.3747		4,500	76,030 (H)							0.0502	8,820	
4-33-20					0.2436	1.136	0.3748		5,400	12,810 (H)							0.0388	6,560	
4-33-25	47D, 52A	19/76/5	Geometry e/d = 3 w/d = 3	0 + Gap	0.2470	1.125	0.3752	0.1	4,900	490	10	95,260 (F)	-	-	5,360	3			
4-33-19					0.2418	1.125	0.3753		5,800	10,210 (F)							0.0388	-	
4-33-28					0.2439	1.125	0.3750		5,500	550							5	1,080 (F)	-
4-33-30					0.2434	1.125	0.3747		3,000	300							10	1,000,000 (N)	0.0304
4-33-23					0.2485	1.124	0.3750		4,500	450							4	65,780 (H)	0.0610
4-33-24					0.2461	1.124	0.3749		7,906	790							10	1,000,000 (N)	0.0148
4-33-21					0.2460	1.125	0.3751		5,500	550							-	3 (M)	0.0784
4-33-27					0.2480	1.124	0.3750		3,000	300							10	1,000,000 (N)	0.0304
5-28-11					0.2280	2.253	0.3697		4,500	450							4	1,004,880 (N)	0.0584
5-24-7					0.2216	2.253	0.3697		7,906	790							10	1,000,000 (N)	0.0148
5-28-21	0.2250	2.252	0.3697	5,500	550	5	740 (H)	0.0624											
5-27-44	0.2260	2.253	0.3699	8,800	880	5 and 10	530,000 (H)	0.0188											
5-28-12	0.2264	2.253	0.3702	5,500	550	5	460 (H)	0.0612											
5-27-47	0.2179	2.253	0.3700	5,900	590	5 and 10	1,000,000 (N)	0.0150											
5-28-37	0.2270	2.252	0.3695	6,900	690	5 and 10	1,000,000 (N)	0.0146											
5-28-20	0.2278	2.252	0.3709	7,500	750	5	492,540 (F)	0.0468											
5-27-24	0.2132	2.254	0.3695	8,100	810	5	231,410 (H)	0.0400											
6-24-47	0.2244	2.254	0.3750	8,100	810	5	5,650 (H)	0.0444											
6-24-43	0.2248	2.253	0.3748	8,100	810	5	1,000 (H)	0.0404											
6-24-40	0.2250	2.253	0.3749	8,100	810	5	1,230 (H)	0.0415											
6-27-46	0.2222	2.254	0.3746	8,100	810	5	-	-											
6-27-13	0.2278	2.250	0.3748	8,100	810	5	-	-											
6-28-19	0.2268	2.254	0.3747	8,100	810	5	-	-											
6-28-23	0.2238	2.254	0.3745	8,100	810	5	-	-											
6-27-7	0.2210	2.254	0.3750	8,100	810	5	-	-											
6-28-32	0.2147	2.254	0.3750	8,100	810	5	-	-											

GP-13-8115-228

TABLE 11. (Continued) CONSTANT AMPLITUDE FATIGUE TEST DATA

Specimen Number	Specimen and Test Setup Configurations (See Figures)	Percent $0^{\circ}/45^{\circ}/90^{\circ}$ Plies	Test Variable	Fastener Torque (in.-lb)	Thickness (in.)	Width (in.)	Hole Dia (in.)	Stress Ratio	Load (lb)		Cyclic Rate (Hz)	Cycles to Failure	Total Head Deflection (in.)	Hole Dia (in.)	Residual Failing Load (lb)	Mode of Failure				
									Max	Min										
6-27-25	47F, 52E		Single Shear C-tank Head	180	0.2230	2.254	0.3747C	0.1	4,100	410	5 and 10	1,000,000 (N)	0.0170	0.377	-	⑦				
6-24-2					0.2177	2.252	0.3748C										0.0184	0.376	8,000	④
6-28-5					0.2212	2.254	0.3749C										0.0170	0.374	-	④
6-27-12					0.2303	2.253	0.3749C										0.0436	0.380	8,550	②
6-24-17					0.2180	2.254	0.3749C										0.0440	0.383	-	④
6-28-16					0.2168	2.251	0.3748C										0.0460	-	-	①
6-24-33					0.2168	2.254	0.3748C										0.0353	0.490	8,500	②
6-27-34					0.2219	2.254	0.3746C										0.0294	0.384	9,780	①
6-27-9					0.2207	2.254	0.3748C										-	-	-	①
7-30-2					0.2376	2.251	0.3750										-	0.379	-	④
7-30-9					0.2347	2.252	0.3746										0.0411	-	10,160	-
7-30-20					0.2353	2.251	0.3746										0.0400	-	9,900	-
7-30-4	0.2353	2.252	0.3746	0.0460	-	9,920	-													
7-30-11	0.2329	2.251	0.3750	0.0394	-	10,000	-													
7-30-22	0.2337	2.250	0.3758	0.0350	0.377	-	④													
7-30-6	0.2346	2.253	0.3749	0.0550	-	9,460	-													
7-30-13	0.2367	2.250	0.3750	0.0496	-	10,510	-													
7-30-32	0.2332	2.251	0.3752	0.0494	-	9,940	-													
7-30-3	0.2340	2.250	0.3747	0.0796	0.428	-	④													
7-30-10	0.2334	2.250	0.3746	0.0812	0.460	-	⑥													
7-30-21	0.2361	2.251	0.3745	0.0820	0.444	10,460	⑤ - ①													
7-30-5	0.2335	2.252	0.3749	0.0682	0.411	-	④													
7-30-12	0.2364	2.250	0.3753	0.0634	0.404	10,320	⑤ - ①													
7-30-28	0.2347	2.250	0.3749	0.0590	0.400	-	⑤													
7-30-7	0.2325	2.249	0.3750	0.0800	0.433	10,060	⑤ - ①													
7-30-14	0.2358	2.250	0.3748	0.0828	0.442	-	⑥													
7-30-34	0.2354	2.237	0.3752	0.0740	0.419	-	⑥													

60114115-237

TABLE 11. (Concluded) CONSTANT AMPLITUDE FATIGUE TEST DATA

Notes:

- ① "C" following hole diameter dimension indicates that hole was countersunk. Dimension noted is the diameter of the hole prior to testing.
- ② Loads were based upon selected percentages of the ultimate static tension strength.
- ③ "V" indicates that rate was varied during testing to permit the MTS machine to function correctly. " " indicates that specimen failed while generating the hysteresis loops for Cycles 1 through 3.
- ④ Cycles to failure data were determined according to the following criteria: (H) - Testing stopped when total head deflection data, as determined by hysteresis loop data, approached or exceeded a preselected dimension. (N) - Testing stopped. (M) - Total head deflection exceeded preselected dimension while generating initial hysteresis loops. (F) - Testing stopped when specimen exhibited complete failure during fatigue cycling.
- ⑤ Total head deflection data were determined from the final hysteresis loop generated for each specimen.
- ⑥ Dimension noted is the major diameter of the elongated hole after shutdown of fatigue testing due to total head deflection data or greater than 10^6 cycles. "-" in hole diameter column indicates that specimen failed during fatigue cycling which prevented hole measurement or that specimen was tested for residual strength before hole measurement was obtained.
- ⑦ Mode of failure legend: ⑤ - ① implies a combination bearing (compression) - shearout mode of failure.

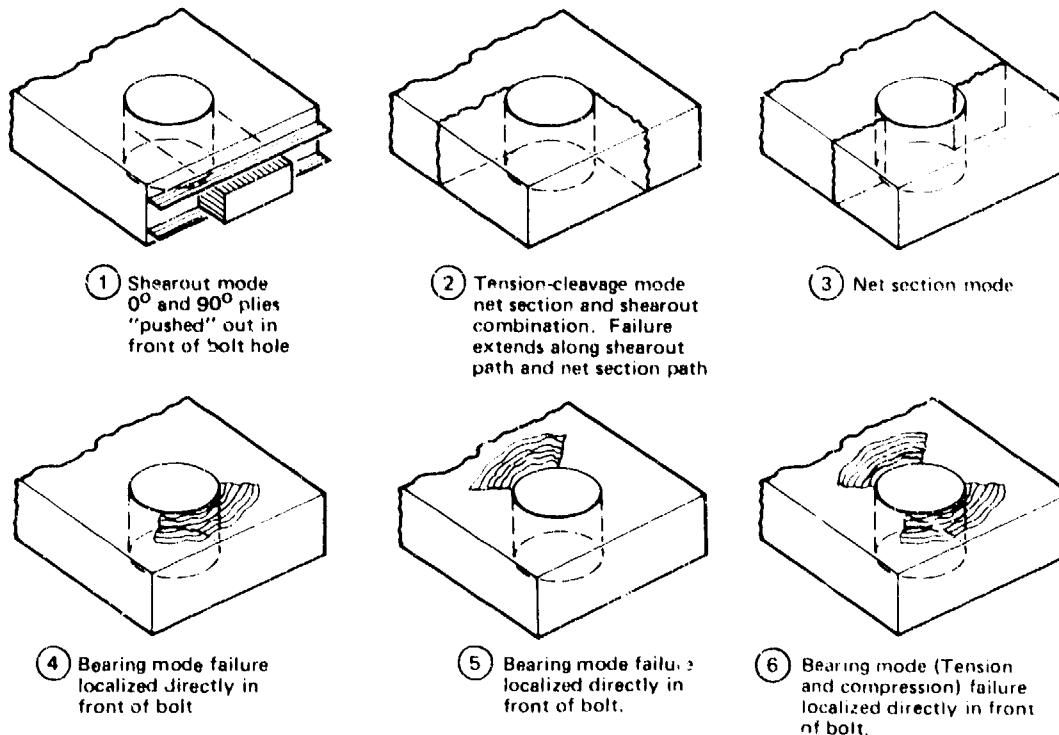

- ⑧ Specimen test results were affected by various anomalies in the test procedures. Specimens affected by these anomalies and the particular anomaly were as follows:
 - 1-28-31 - Wrong size bolt used in test setup.
 - 1-25-30 - Residual strength test conducted with no nut on bolt.
 - 3-27-17 - Wrong load programmed into MTS machine at restart after generating hysteresis loop at 12,140 cycles resulting in failure of specimen.
 - 3-28-17 - Specimen failed at 25,140 cycles due to an overload condition in the MTS.
 - 3-32-25 - Failed during initial startup due to an overload condition in the MTS.
 - 7-30-6 - Washers not installed between load block surface and bushing head to maintain 0 torque + gap condition.
 - 7-30-34 - Specimen overloaded on tension side at restart after generating hysteresis loop at 93,560 cycles resulting in excessive hole elongation.

GP13-0115-238

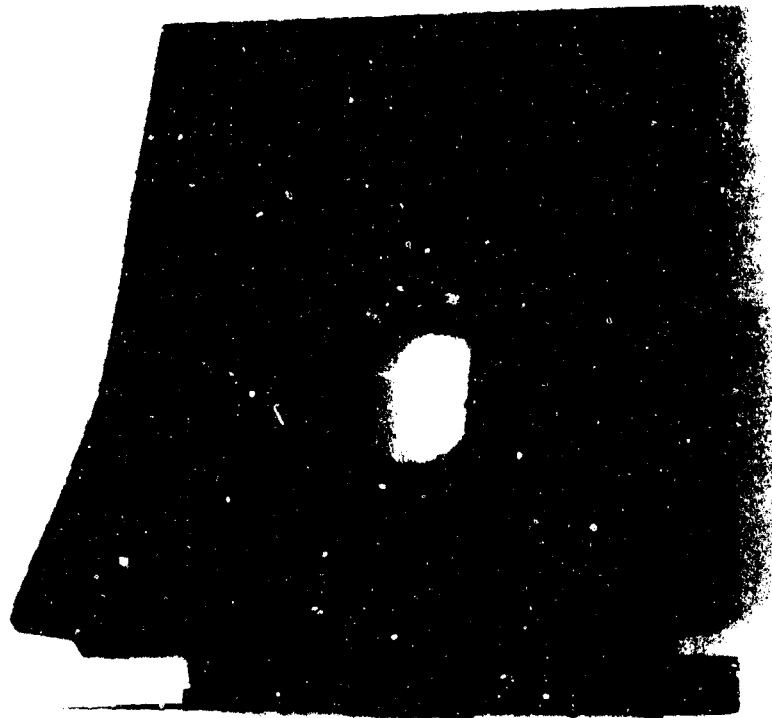

Tension - Cleavage

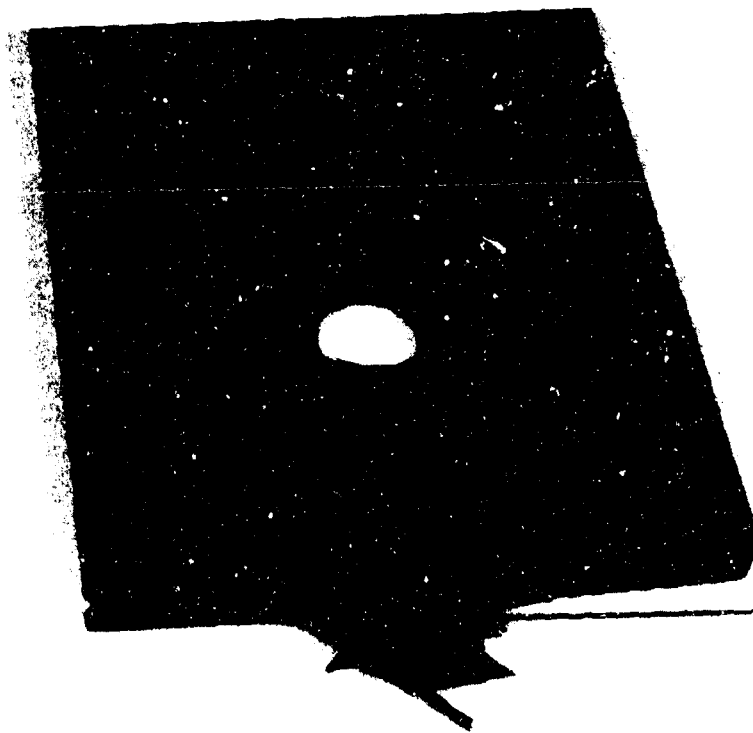

Shearout

GP13-0115-254

Figure 55. Constant Amplitude ($R = 0.1$) Tension - Cleavage and Shearout Modes of Failure

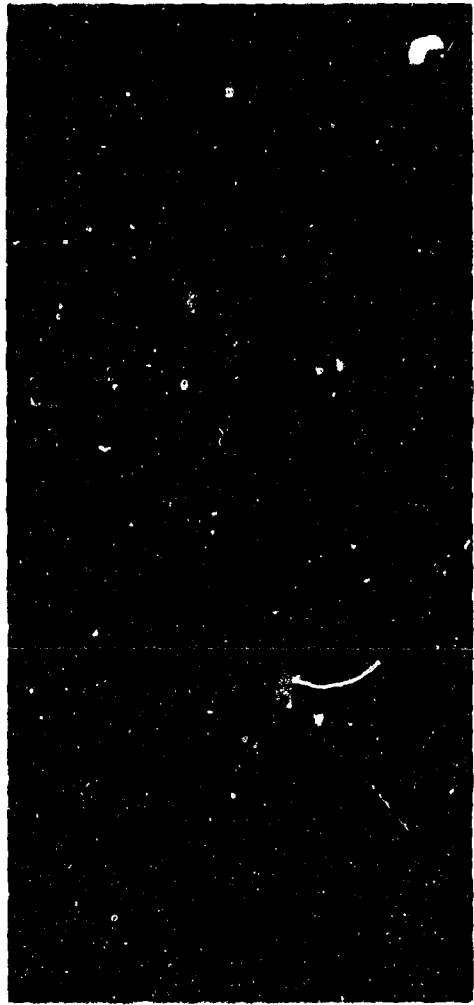

Bearing (Tension Side)



Tension - Cleavage

GF12-0115-253

Figure 56. Constant Amplitude ($R = 0.1$) Bearing and Tension - Cleavage
Modes of Failure



Net Section



Tension - Cleavage

GP13-0115-252

Figure 57. Constant Amplitude ($R = 0.1$) Net Section and Tension - Cleavage Modes of Failure

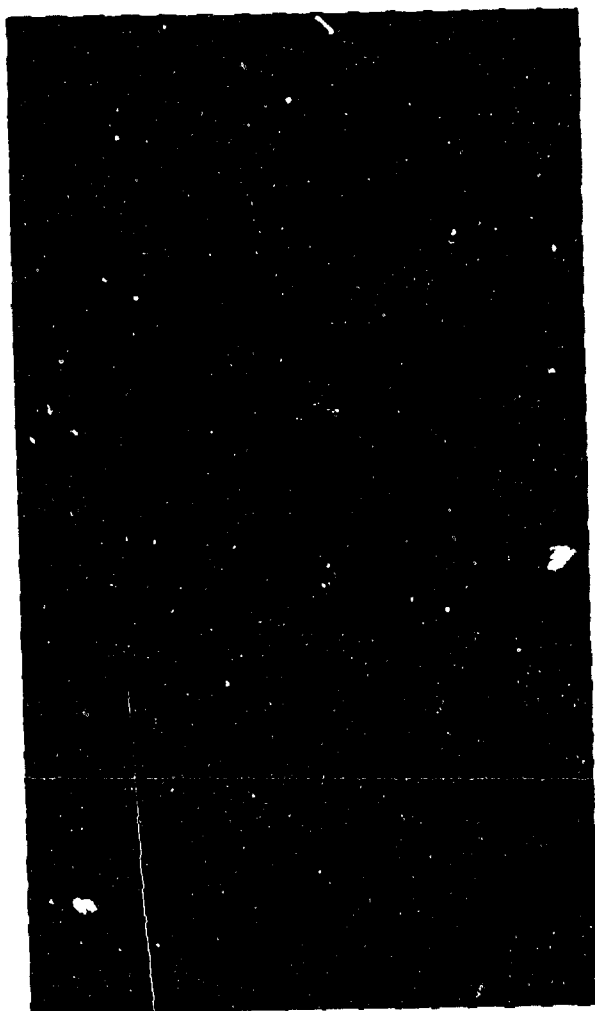

Bearing (Compression Side)



Bearing (Tension and Compression Sides)

QP13-0115-251

Figure 58. Constant Amplitude ($R = -1.0$) Bearing Modes of Failure

TABLE 12. SPECTRUM FATIGUE TEST DATA

Specimen Number	Specimen and Test Setup Configurations (See Figures)	Percent 0°/45°/90° Plies	Test Variable	Moisture Content (% by Wt)		Test Temp	Fastener Torque (in.-lb)	Thickness (in.)	Width (in.)	Hole dia (in.)	100% TLL (lb)	Flight hr to Failure	Total Head Deflection (in.)	Hole dia (in.)	Residual Failing Load (lb)	Mode of Failure
				Initial	Final											
1-24-1	47A, 52F	50/40/10	Baseline	0.72	0.73	RT	0 + Gap	0.2155	2.254	0.3748	6,500	12,000 (H)	0.1410	0.506	-	④
1-27-3				0.78	0.78			0.2273	2.254	0.3748	6,500	0.0210	0.374	8,670	②	
1-28-26				0.83	0.83			0.2267	2.255	0.3747	16,000 (N)	0.0215	0.374	-	④	
1-27-28				0.82	0.81			0.2286	2.255	0.3747	5,500	0.0175	0.374	-	①	
1-27-45				0.75	0.74			0.2258	2.251	0.3745	9,151 (F)	0.0170	0.374	8,560	④	
1-27-41				0.72	0.71			0.2131	2.255	0.3747	16,000 (N)	0.0175	0.374	-	④	
1-24-9				0.77	0.77			0.2129	2.254	0.3749	7,000	0.2213 (D)	-	-	-	①
1-28-29				0.84	0.84			0.2257	2.252	0.3745	7,000	0.1045	0.468	8,010	-	④
1-28-24				0.78	0.79			0.2143	2.255	0.3745	8,000 (H)	0.1360	0.504	-	-	④
1-24-11				0.88	ND			0.2291	2.257	0.3751	3,500	0.0145	0.377	8,660	-	①
1-28-30				0.83	ND			0.2272	2.255	0.3747	3,500	0.0145	0.376	-	-	④
1-27-27				0.86	0.73			0.2279	2.263	0.3745	4,000	0.0190	0.360	-	-	④
1-27-19				0.84	RH			0.2276	2.253	0.3745	16,000 (N)	0.0145	0.376	-	-	①
1-24-25	0.79	RH	0.2178	2.255	0.3750	4,000	0.0150	0.376	7,540	-	①					
1-24-28	0.84	RH	0.2271	2.253	0.3753	4,200	0.0145	0.376	-	-	④					
1-27-16	0.76	0.68	0.2171	2.255	0.3745	4,200	0.0150	0.374	8,540	-	①					
1-28-13	0.85	0.77	0.2242	2.255	0.3749	4,400	0.0160	0.375	-	-	④					
1-28-28	0.81	RH	0.2280	2.253	0.3745	4,600	0.0125	0.374	-	-	④					
1-24-27			0.2312	2.254	0.3747	32,000 (N)	0.0550	0.409	8,080	-	①					
1-27-1			0.2167	2.253	0.3754	6,500	0.1488	0.507	-	-	④					
1-27-4			0.2275	2.254	0.3749	6,500	0.0265	0.380	-	-	④					
1-24-4			0.2218	2.255	0.3748	5,500	0.0165	0.374	-	-	④					
1-27-11			0.2295	2.254	0.3745	5,500	0.0165	0.374	8,980	-	①					
1-28-3			0.2208	2.252	0.3745	7,000	0.0160	0.373	-	-	④					
1-24-15			0.2256	2.254	0.3751	7,000	0.0485	0.398	-	-	④					
1-27-29			0.2250	2.252	0.3746	7,000	0.0545	0.410	9,240	-	①					
1-27-26			0.2250	2.254	0.3747	16,000 (N)	0.0615	0.425	-	-	④					
1-24-42			0.2238	2.254	0.3748	6,500	0.0792	0.434	8,150	-	①					
1-28-1			0.2136	2.253	0.3748	6,500	0.0910	0.441	-	-	④					
1-24-13			0.2292	2.252	0.3749	16,000 (N)	0.0540	0.411	-	-	④					

①②③④

GP15416-216

TABLE 12. (Continued) SPECTRUM FATIGUE TEST DATA

Specimen Number	Specimen and Test Setup Configurations (See Figures)	Percent 0°/45°/90° Plies	Test Variable	Moisture Content (% by Wt)		Test Temp	Fastener Torque (in.-lb)	Thickness (in.)	Width (in.)	Hole dia (in.)	100% TLL (lb)	Flight hr to Failure	Total Head Deflection (in.)	Hole dia (in.)	Residual Fatigue Load (lb)	Mode of Failure
				Initial	Final											
1-27-20	47A, 52F	50/40/10	Baseline	0.87	0.88	RT	0 + Gap	0.2270	2.253	0.3745	5,500	16,000 (N)	0.0175	0.374	9,140	①
1-27-6				0.81	0.81			0.2236	2.254	0.3747	5,500	16,000 (N)	0.0180	0.375	-	④
1-27-22				0.87	0.88			0.2234	2.253	0.3745	7,000	7,000 (H)	0.0180	0.374	8,850	①
1-27-36				0.90	0.89			0.2298	2.251	0.3745	7,000	7,000 (H)	0.0690	0.422	-	④
1-24-32				0.89	0.90			0.2270	2.251	0.3748	7,000	7,000 (H)	0.0820	0.431	-	④
1-24-16				0.89	0.89			0.2188	2.253	0.3748	6,500	32,000 (N)	0.0930	0.442	-	④
1-25-21								0.2292	2.255	0.3745	4,900	32,000 (N)	0.0235	0.374	19,400	②
1-25-3								0.2296	2.253	0.3747	4,900	32,000 (N)	0.0360	0.386	-	④
1-25-17								0.2298	2.254	0.3746	4,900	32,000 (N)	0.0395	0.388	-	④
1-25-8								0.2163	2.255	0.3747	4,900	32,000 (N)	0.0160	0.373	9,360	②
1-25-4			0.2300	2.255	0.3748	7,000	16,000 (N)	0.0165	0.375	-	④					
1-25-24			0.2276	2.254	0.3746	7,000	16,000 (N)	0.0165	0.372	-	④					
1-25-26			0.2323	2.255	0.3745	7,000	16,000 (N)	0.0455	0.399	10,680	②					
1-25-11			0.2320	2.255	0.3748	7,000	16,000 (N)	0.0435	0.396	-	④					
1-25-19			0.2167	2.255	0.3747	7,000	9,000 (H)	0.0985	0.452	-	④					
1-32-11			0.2429	2.251	0.3754	7,000	9,000 (H)	0.0465	0.391	11,280	②					
1-32-14			0.2420	2.252	0.3757	7,000	9,000 (H)	0.0455	0.391	11,280	②					
1-32-24			0.2342	2.251	0.3749	7,000	9,000 (H)	0.0840	0.426	-	④					
1-32-26			0.2410	2.251	0.3748	7,000	9,000 (H)	0.0195	0.374	-	④					
1-32-28		19/76/5	0.2417	2.251	0.3747	7,000	9,000 (H)	0.0185	0.373	11,120	②					
1-32-12			0.2438	2.251	0.3756	7,000	9,000 (H)	0.0185	0.373	-	④					
1-32-30			0.2431	2.251	0.3746	7,000	9,000 (H)	0.0225	0.373	-	④					
1-32-1			0.2278	2.251	0.3755	7,000	9,000 (H)	0.0365	0.382	-	④					
1-33-32			0.2439	2.250	0.3752	7,000	9,000 (H)	0.0225	0.374	11,680	②					
2-26-21			0.2277	2.255	0.3745	7,000	9,000 (H)	0.0160	0.373	-	④					
2-26-3			0.2265	2.254	0.3745	7,000	9,000 (H)	0.0420	0.406	-	④					
2-26-17			0.2273	2.186	0.3745	7,000	9,000 (H)	0.0150	0.373	8,340	①					
2-26-8	50/40/10 Special Panel No. 26	Stacking Sequence	0.2207	2.254	0.3747	7,000	9,000 (H)	0.0920	0.444	-	④					
2-26-4			0.2259	2.255	0.3747	7,000	9,000 (H)	0.0505	0.412	8,960	①					
2-26-24			0.2278	2.254	0.3749	7,000	9,000 (H)	0.0330	0.392	-	④					

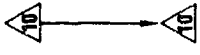

91-1515-578

TABLE 12. (Continued) SPECTRUM FATIGUE TEST DATA

Specimen Number	Specimen and Test Setup Configurations (See Figures)	Percent 0°/45°/90° Piles	Test Variable	Moisture Content (% by Wt)		Test Temp	Fastener Torque (in.-lb)	Thickness (in.)	Width (in.)	Hole dia (in.)	100% TLL (lb)	Flight hr to Failure	Total Head Deflection (in.)	Hole dia (in.)	Residual Failing Load (lb)	Mode of Failure							
				Initial	Final																		
2-26-26	47A, 52F	50/40/10 Special Panel No. 26	Stacking Sequence			RT	0 + Gap	0.2358	2.254	0.3746	5,500	16,000 (N)	0.0165	0.374	-	④							
2-26-11								0.2325	2.255	0.3750			0.0170	0.374	8,680	④							
2-26-19								0.2142	2.254	0.3748			0.0175	0.374	-	④							
2-31-21								0.2390	2.249	0.3753			0.0425	0.388	11,200	②							
2-31-3								0.2355	2.251	0.3750			0.0380	0.390	-	④							
2-31-17		19/76/5 Special Panel No. 31						Torque Up	50/40/10				RT	180	0.2401	2.251	0.3748	7,000	16,000 (N)	0.0325	0.385	-	④
2-31-8															0.2313	2.251	0.3745			0.0235	0.374	-	④
2-31-4															0.2366	2.251	0.3748			0.0220	0.374	11,280	②
2-31-24															0.2342	2.250	0.3760			0.0245	0.375	-	④
2-31-26															0.2445	2.251	0.3760			0.0205	0.376	-	④
2-31-11	47A, 52B	19/76/5	Torque Up			RT	180	0.2452	2.251	0.3750	7,300	16,000 (N)	0.0190	0.373	-	②							
2-31-19								0.2301	2.250	0.3752			0.0200	0.374	10,360	②							
3-27-42								0.2227	2.255	0.3745			0.0230	0.374	-	④							
3-24-39								0.2285	2.254	0.3749			0.0225	0.374	10,380	②							
3-24-8								0.2166	2.254	0.3748			0.0225	0.375	-	④							
3-24-18								0.2263	2.254	0.3748			0.0175	0.373	-	④							
3-27-48								0.2110	2.255	0.3745			0.0165	0.373	11,220	①							
3-27-33								0.2176	2.255	0.3745			0.0255 (D)	-	-	①							
3-24-3	0.2212	2.255	0.3749	0.0220 (D)	-	-	①																
3-27-32	0.2097	2.254	0.3745	-	-	-	①																
3-24-30	47A, 52B	19/76/5	Torque Up			RT	0 + Gap	0.2300	2.254	0.3746	11,000	16,000 (N)	0.0325 (D)	0.373	12,960	③							
3-32-16								0.2279	2.251	0.3754			0.0400	0.373	-	③							
3-32-37								0.2424	2.223	0.3756			0.0380 (D)	-	-	④							
3-32-22								0.2435	2.250	0.3749			0.0400	0.374	-	④							
3-32-8								0.2317	2.250	0.3747			0.0300	0.372	12,840	③							
3-32-42								0.2413	2.250	0.3749			0.0290	0.368	-	④							
3-32-20								0.2433	2.250	0.3750			0.0295	0.374	-	④							
3-33-5								0.2450	0.249	0.3752			0.0260	0.375	-	④							
3-32-33	0.2274	2.250	0.3747	0.0460	0.394	-	②																
3-32-38	0.2424	2.245	0.3752	0.0325	0.382	12,100	②																



TABLE 12. (Concluded) SPECTRUM FATIGUE TEST DATA

Notes:

- ① Data in the initial column is the moisture content of the specimen after removal from humidity exposure. Data in the final column is the moisture content of the specimen after spectrum fatigue testing based upon traveler coupon moisture content data. "ND" indicates that no data was obtained. "PH" indicates that the traveler coupon was returned to humidity exposure after completion of testing resulting in an increase in moisture content. "NA" indicates that the specimens were not exposed.
- ② Specimens tested at 250°F were at 250°F for 10 minutes prior to testing.
- ③ Thickness and width dimensions were determined at the hole location. Dimensions for the humidity exposed specimens were determined prior to humidity exposure.
- ④ Dimension noted is the diameter of the hole prior to testing.
- ⑤ Loads were based upon selected percentages of the ultimate static tension strength.
- ⑥ Flight hours to failure data were determined according to the following criteria: (H) = Testing stopped when total head deflection data, as determined by hysteresis loop data, approached or exceeded a preselected dimension. (N) = Testing stopped if failure did not occur after a preselected number of flight hours. (F) = Testing stopped when specimen exhibited complete failure during fatigue cycling.
- ⑦ Total head deflection data were determined from the final hysteresis loop generated for each specimen tested. Hysteresis loops were generated for each specimen at 1,000 flight hour intervals. "D" in total head deflection column indicates that the deflection data noted was obtained from the incremental flight hours hysteresis loop generated immediately prior to specimen failure.
- ⑧ Dimension noted is the major diameter of the elongated hole after shutdown of fatigue testing due to total head deflection data.
- ⑨ Mode of failure legend: ② - ① Implies a combination tension-cleavage-shearout mode of failure.

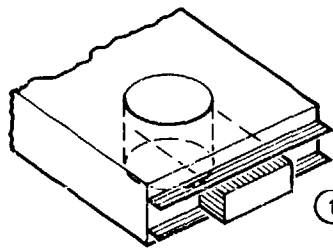

① Shearout mode
 0° and 90° plies
 "pushed" out in
 front of bolt hole

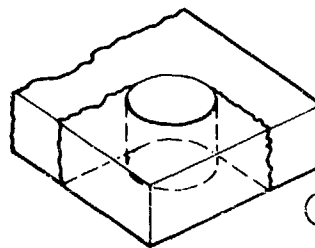

② Tension-cleavage mode
 net section and shearout
 combination. Failure
 extends along shearout
 path and net section path

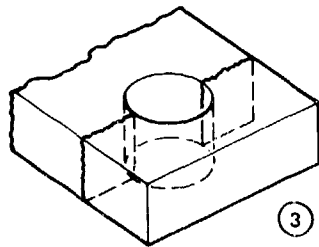

③ Net section mode

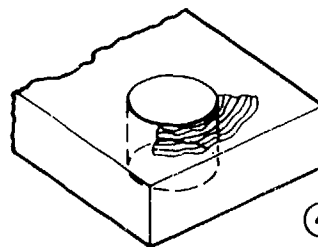

④ Bearing mode failure
 localized directly in
 front of bolt

- ⑩ Specimens were thermal spiked prior to testing.
- ⑪ Specimen test results were affected by various anomalies in the test procedures. Specimens affected by these anomalies and the particular anomaly were as follows: 3-24-3 - Wrong load range programmed into MTS resulting in overloading of specimen. 3-27-32 - Wrong load range programmed into MTS resulting in specimen failure due to overloading. 3-32-37 - Wrong load programmed into MTS after completion of generation of hysteresis loop at 12,000 flight hours. Specimen failed during startup after completion of generating hysteresis loop due to overloading. Specimen failed at 3,325 pounds.
- ⑫ Specimens were tested using the "RS01" spectrum. P_{max} was 101% of TLL and P_{min} was -26.1% of TLL.
- ⑬ Specimen numbers 1-25-8, 1-25-4 and 1-25-24 were tested using a cyclic rate of 10 Hz. All other specimens were tested using a cyclic rate of 8 Hz.

GP13-0115-243

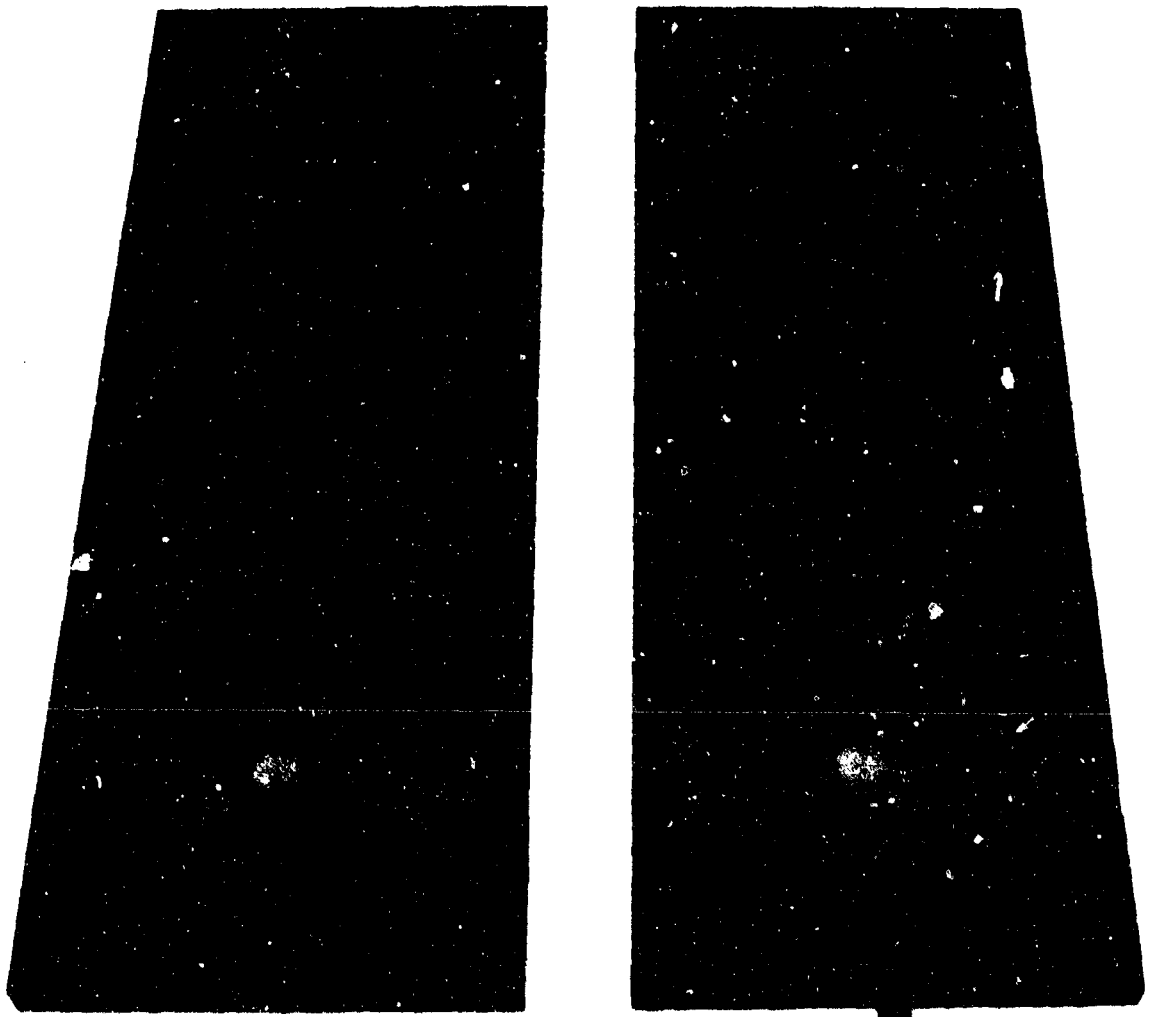

Bearing (Tension Side)

Bearing - Shearout

GP13-0115-214

Figure 59. Spectrum Fatigue Bearing and Bearing - Shearout Modes of Failure