



AD-A154 949

AFAMRL-TR-85-016

THE MEASUREMENT OF AIRCRAFT WINDSCREEN HAZE
AND ITS EFFECT ON VISUAL PERFORMANCE

H. LEE TASK, Ph.D.
LOUIS V. GENCO, O.D., LT COL, USAF

AIR FORCE AEROSPACE MEDICAL RESEARCH LABORATORY

FEBRUARY 1985

DTIC
ELECTR
JUN 12 1985
G P

Approved for public release; distribution unlimited.

DTIC FILE COPY

AIR FORCE AEROSPACE MEDICAL RESEARCH LABORATORY
AEROSPACE MEDICAL DIVISION
AIR FORCE SYSTEMS COMMAND
WRIGHT-PATTERSON AIR FORCE BASE, OHIO 45433-6573

85 5 20 08 I

NOTICES

When US Government drawings, specifications, or other data are used for any purpose other than a definitely related Government procurement operation, the Government thereby incurs no responsibility nor any obligation whatsoever, and the fact that the Government may have formulated, furnished, or in any way supplied the said drawings, specifications, or other data, is not to be regarded by implication or otherwise, as in any manner licensing the holder or any other person or corporation, or conveying any rights or permission to manufacture, use, or sell any patented invention that may in any way be related thereto.

Please do not request copies of this report from Air Force Aerospace Medical Research Laboratory. Additional copies may be purchased from:

National Technical Information Service
5285 Port Royal Road
Springfield, Virginia 22161

Federal Government agencies and their contractors registered with Defense Technical Information Center should direct requests for copies of this report to:

Defense Technical Information Center
Cameron Station
Alexandria, Virginia 22314

TECHNICAL REVIEW AND APPROVAL

AFAMRL-TR-85-016

This report has been reviewed by the Office of Public Affairs (PA) and is releasable to the National Technical Information Service (NTIS). At NTIS, it will be available to the general public, including foreign nations.

This technical report has been reviewed and is approved for publication.

FOR THE COMMANDER



CHARLES BATES, JR.
Director, Human Engineering Division
Air Force Aerospace Medical Research Laboratory

SECURITY CLASSIFICATION OF THIS PAGE

| REPORT DOCUMENTATION PAGE | | | | |
|---|---|--|---|--------------------|
| 1a REPORT SECURITY CLASSIFICATION UNCLASSIFIED | | 1b RESTRICTIVE MARKINGS | | |
| 2a SECURITY CLASSIFICATION AUTHORITY | | 3 DISTRIBUTION/AVAILABILITY OF REPORT Approved for public release; distribution is unlimited. | | |
| 2b DECLASSIFICATION/DOWNGRADING SCHEDULE | | | | |
| 4 PERFORMING ORGANIZATION REPORT NUMBER(S) AFAMRL-TR- 85-016 | | 5 MONITORING ORGANIZATION REPORT NUMBER(S) | | |
| 6a NAME OF PERFORMING ORGANIZATION AFAMRL, Human Engineering Division, AMD, AFSC | 6b OFFICE SYMBOL (If applicable) HEF | 7a NAME OF MONITORING ORGANIZATION | | |
| 6c ADDRESS (City, State and ZIP Code) Wright-Patterson AFB OH 45433-6573 | | 7b ADDRESS (City, State and ZIP Code) | | |
| 8a NAME OF FUNDING/SPONSORING ORGANIZATION Air Force Aerospace Medical Rsch Lab | 8b OFFICE SYMBOL (If applicable) HEF | 9 PROCUREMENT INSTRUMENT IDENTIFICATION NUMBER | | |
| 8c ADDRESS (City, State and ZIP Code) Wright-Patterson AFB OH 45433 | | 10 SOURCE OF FUNDING NOS | | |
| 11 TITLE (Include Security Classification) The Measurement of Aircraft Windscreen Haze And Its Effect On | | PROGRAM ELEMENT NO 62202F | PROJECT NO 7184 | TASK NO 18 |
| | | | | WORK UNIT NO 06 |
| 12 PERSONAL AUTHOR(S) Visual Performance (U) Task, H. Lee, Ph.D. Genco, Louis V., O.D., Lt Col, USAF | | | | |
| 13a TYPE OF REPORT final | 13b TIME COVERED FROM _____ TO _____ | 14 DATE OF REPORT (Yr. Mo. Day) 1985 February | 15 PAGE COUNT 46 | |
| 16 SUPPLEMENTARY NOTATION | | | | |
| 17 COSATI CODES | | 18 SUBJECT TERMS (Continue on reverse if necessary and identify by block number) | | |
| FIELD 06 | GROUP 16 | SUB GR | Optics Optical Quality; Aircraft Transparencies | |
| | | | Target Detection Vision; Haze | |
| 19 ABSTRACT (Continue on reverse if necessary and identify by block number) A new method of measuring haze in installed aircraft transparencies is developed and explained. Using data obtained with the new method, equations were derived to help predict target detection performance as it is affected by windscreen haze, windscreen transmissivity, ambient illumination, mean target luminance, target contrast and target size. The equations may be applied to many transparency types and configurations. Graphs are provided to show the effects of a number of typical visibility conditions. No similar relationships were found for older methods of measuring haze. Keywords: | | | | |
| 20 DISTRIBUTION/AVAILABILITY OF ABSTRACT UNCLASSIFIED/UNLIMITED <input checked="" type="checkbox"/> SAME AS RPT <input type="checkbox"/> DTIC USERS <input type="checkbox"/> | | 21 ABSTRACT SECURITY CLASSIFICATION UNCLASSIFIED | | |
| 22a NAME OF RESPONSIBLE INDIVIDUAL H. Lee Task, Ph.D. | | 22b TELEPHONE NUMBER (Include Area Code) 513-255-7585 | 22c OFFICE SYMBOL AFAMRL/HEF | |

PREFACE

This report was prepared by members of the Crew Systems Effectiveness Branch of the Human Engineering Division, Air Force Aerospace Medical Research Laboratory, Wright-Patterson Air Force Base, Ohio. The work was performed under Task 7134-18, "Visual Effects of Windscreens on Pilot Performance". Funding for this effort was provided by the Air Force Wright Aeronautical Laboratories, Flight Dynamics Laboratory, Vehicle Equipment ADP Branch (AFWAL/FIEA). The authors express their appreciation to systems Research Laboratories, particularly Ms. Becky Unger and Mr. Rob Love who assisted in the stimulus generation, data collection and reduction, and Ms. Diana Nelson, Ph.D., who assisted in background investigations and data analyses.

| | |
|---------------------------|-------------------------------------|
| Accession For | |
| NTIS GRA&I | <input checked="" type="checkbox"/> |
| DTIC TAB | <input type="checkbox"/> |
| Unannounced | <input type="checkbox"/> |
| Justification | |
| By _____ | |
| Distribution/ | |
| Availability Codes | |
| Dist. | Avail and/or Special |
| A/1 | |



TABLE OF CONTENTS

| <u>TITLE</u> | <u>PAGE</u> |
|--|-------------|
| INTRODUCTION | 5 |
| TEST METHOD BACKGROUND | 5 |
| NEW HAZE MEASUREMENT TECHNIQUE | 7 |
| CONTRAST LOSS DUE TO HAZE | 12 |
| HAZE MEASUREMENT TEST RESULTS | 19 |
| CONCLUSIONS | 32 |
| APPENDIX | 33 |
| REFERENCES | 42 |

LIST OF ILLUSTRATIONS

| <u>FIGURE NO.</u> | | <u>PAGE</u> |
|-------------------|---|-------------|
| 1. | Conservation of Light Energy: $I=S+T+A+R$ | 6 |
| 2. | Geometry for Measuring the Veiling Luminance Due to Scattering in the Windscreen | 9 |
| 3. | Geometry for Measuring the Transmission Coefficient of the Windscreen | 11 |
| 4. | Contrast Loss for Different Transmissivities Versus Haze Index for a Sunny Day | 17 |
| 5. | Contrast Loss Versus Haze Ratio for Bright Day Viewing Toward Sun | 17 |
| 6. | Contrast Loss Versus Haze Ratio for Bright Day Viewing at Moderate Angle From Sun | 18 |
| 7. | Contrast Loss Versus Haze Index for Bright Day Viewing at a Large Angle from the Sun | 18 |
| 8. | Contrast Loss Versus Haze Index for Bright Day Viewing Almost Directly Away from the Sun | 19 |
| 9. | The Contrast Loss Measurement Kit | 20 |
| 10. | Angular Subtense at Detection Versus Contrast for a Dark Circular Disk on a Light Background | 29 |

LIST OF TABLES

| <u>TABLE NO.</u> | | <u>PAGE</u> |
|------------------|---|-------------|
| 1. | F-111 Plastic Windscreen, Lab Measurements | 21 |
| 2. | F-111 Glass Windscreen, Lab Measurements | 21 |
| 3. | Contrast Loss and Haze Index Measurements for A-10 Gun Gas Residue Tests (Clean Windscreen) | 22 |
| 4. | Contrast Loss and Haze Index Measurements for A-10 Gun Gas Residue Tests (After Cannon Firing) | 22 |
| 5. | Contrast Loss and Haze Index Measurements in LANTIRN HUD Combiners | 24 |
| 6. | F-16 Windscreen and LANTIRN HUD Contrast Loss and Haze Index Measurements | 25 |
| 7. | Typical Values of Haze Index, Transmissivity and Haze Ratio for Various Transparencies | 26 |

INTRODUCTION

Within the last decade the use of plastic instead of glass for the manufacture of aircraft windscreens has increased considerably. This use of plastic has resulted in a noticeable decrease in the optical quality of the windscreens. Although highly effective in providing improved birdstrike protection, the plastic windscreens have given rise to several optical degradation effects such as rainbowning (birefringence), multiple imaging, distortion and haze. The purpose of this report is to describe a recently developed technique to measure haze in aircraft transparencies (including visors and HUDs) and relate these measurements to visual performance.

TEST METHOD BACKGROUND

The presently accepted method of measuring haze is based on a technique developed at the National Bureau of Standards (NBS). This method has been adopted as a haze measurement standard by the American Society for Testing and Materials (ASTM) and by the Federal Government. The Gardner Haze Meter (R) is a specific device used to measure haze based on this method.

Light incident on a transparent medium can be absorbed, reflected, scattered or transmitted. Since light (energy) must be conserved, the quantities of absorbed(A), reflected(R), scattered(S), and transmitted(T) light must add up to the amount of incident light(I) (see Fig 1). The scattered and transmitted light are the two parts of interest for measuring haze using the NBS method. In this case the total light that passes through the transparency is equal to the amount transmitted plus the amount scattered. Only the transmitted portion is usable to form an image of the object from which the light originated; the scattered light has lost its image forming information.

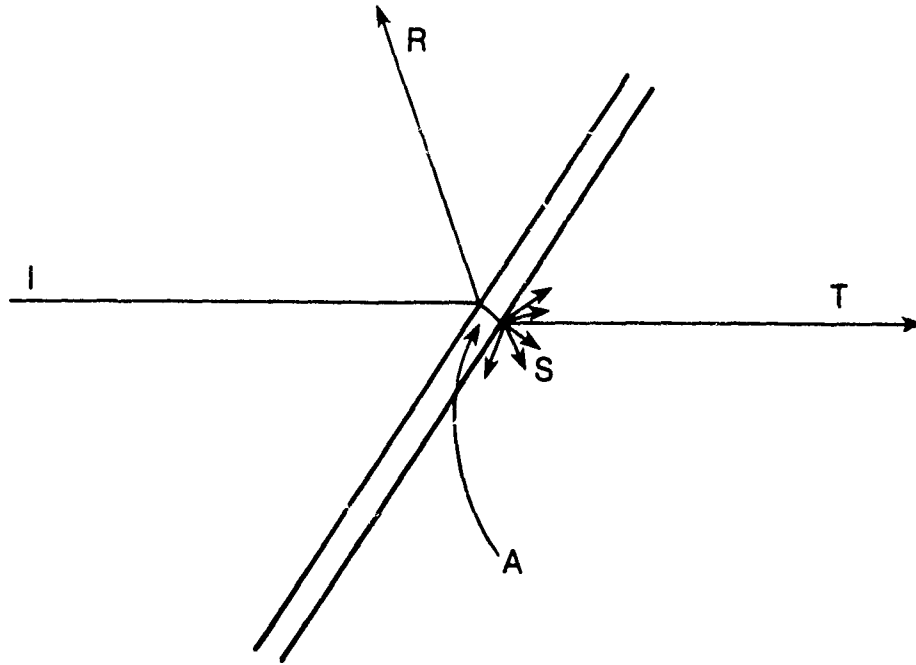

Figure 1. Conservation of light energy: $I=S+T+A+R$

The NBS definition of haze is the ratio of the scattered light to the total light that comes through the transparency ($S + T$). In equation form:

$$H = \frac{S}{(S + T)} \quad (1)$$

where: H = Haze
S = Scattered light
T = Transmitted (image forming) light

Values of haze can range from 0 (no scattering) to 1 (total scattering). Although the definition seems quite reasonable and the haze values are bounded and well behaved, it is not possible to directly relate the haze value to contrast loss and visual performance degradation. In addition, the instrumentation is designed specifically for relatively small, thin, unscratched, eflat samples that can be placed flush with the entrance aperture of the integrating sphere used to make the measurements. Thus it is not useable for measuring the haze of an aircraft transparency while it is installed on the aircraft. Because of these significant disadvantages, a new method for measuring and defining haze was developed that can be directly related to contrast loss and observer performance and can be used to measure windscreens while they remain installed on the aircraft.

NEW HAZE MEASUREMENT TECHNIQUE

Haze in transparencies refers to the property that visually corresponds to the loss of available scene contrast which occurs when looking through the transparency. This contrast loss is a result of light scattering into the line of vision, and appears as a veiling luminance. A common example of veiling luminance is experienced when one tries to look out the window of a brightly illuminated room at night. Under most conditions, the exterior scene is masked (veiled) by the room light reflected in the window. If the window were shaded (or the room lights dimmed sufficiently), exterior vision would be greatly improved.

The level of the veiling luminance is proportional to the illumination falling on the surface of the transparency. The haze index is defined as the proportionality constant that relates the illumination level to the veiling luminance level; in equation form:

$$H_i = \frac{L}{E} \quad (2)$$

where:

H_i = haze index

L = veiling luminance (foot-lamberts)

E = Illumination at surface of transparency (foot-candles)

The value of the haze index is in units of luminance/illuminance such as foot-lamberts per foot-candle. It should be noted that the haze value is highly dependent on the geometry of the illuminating source and the angle of view through the transparency. This may at first seem to be a disadvantage of this method over the nondirectional NBS haze method. It is certainly less convenient; however, it does directly relate with visibility through the transparency which also varies with the illuminating and viewing geometry.

The haze index can be measured both in the laboratory and in the field using similar techniques. For laboratory measurement a semicollimated light source is used to illuminate the transparency to be measured. A photometer* is used on the opposite side of the transparency to measure the veiling luminance within the transparency. A black, light absorbing surface must be placed in the line of measurement of the photometer to insure that the luminance being measured is only the scattered light and not a combination of scattered and transmitted light. Figure 2 shows the measurement geometry.

*Hand-held photometer capable of measuring luminances over the range of 0.1 cd/m^2 to 5000 cd/m^2 , and with a spot size of 0.33 to 1 degree (similar to a Minolta Spot Luminance Meter or equivalent).

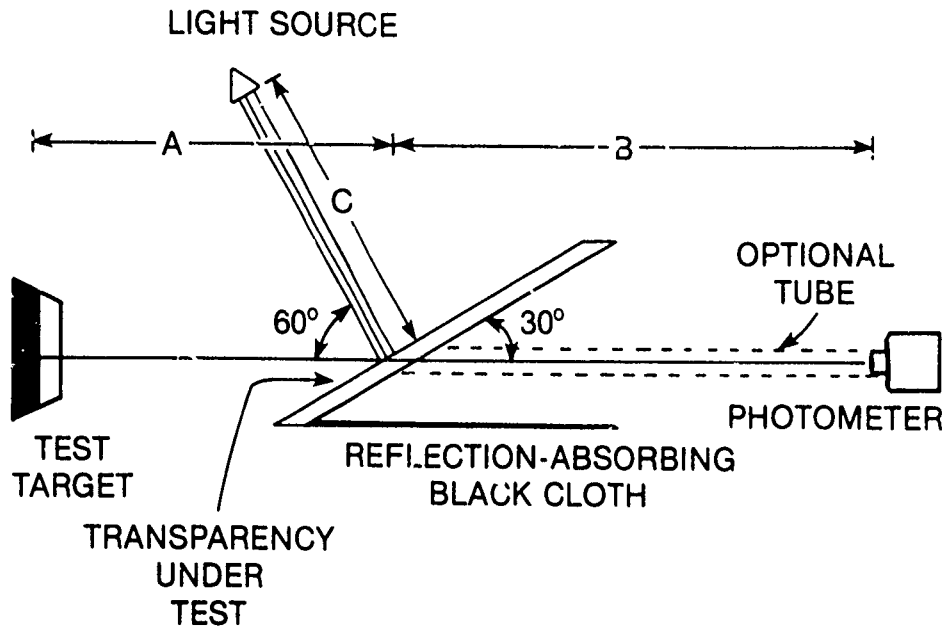

Figure 2. Geometry for measuring the veiling luminance due to scattering in the windscreen.

The illumination falling on the surface of the transparency can be measured using the same photometer by making use of a Lambertian reflector. A Lambertian reflector is a surface that reflectively scatters all incident light in a perfectly diffusing fashion. Because of the way in which foot-candles (illumination) and foot-lamberts (luminance) are defined, the luminance of a perfectly diffusing reflector in foot-lamberts is numerically equivalent to the illuminance in foot-candles falling on the surface. Thus one can place a Lambertian reflector (such as a Barium Sulphate plate) on the surface of interest, and measure its luminance in foot-lamberts (which is numerically equal to the illumination on the surface in foot-candles). Once the veiling luminance and the illumination are measured, the haze index can be calculated using equation (2). To fully characterize the transparency, the haze index should be measured for all illumination and viewing angles of interest.

The haze index can be measured on installed aircraft transparencies in a manner similar to that used in the laboratory with some minor modifications. Instead of using an artificial light source one can use actual sunlight if the sun is oriented correctly for the desired measurement. Under field conditions, the black area of the test target, not being a perfect light trap, will usually reflect enough light that it must be considered when calculating the haze index. This is done by measuring the luminance of the black area directly (not through the windscreen), multiplying it by the transmission coefficient of the transparency and subtracting this luminance from the measured veiling luminance. This operation has the effect of removing the transmitted luminance from the veiling luminance reading. Therefore the haze index in equation form is:

$$H_i = \frac{L - Bt}{E} \quad (3)$$

where: H_i = haze index

L = veiling luminance measurement

B = luminance of the black target without windscreen

E = illumination at surface of windscreen

t = transmission coefficient of the windscreen

Note that equation (3) reduces to equation (2) when the black target luminance is very low (i.e. $B=0$).

It is evident from equation (3) that it is also necessary to measure the transmission coefficient of the windscreen in order to obtain accurate results. The transmission coefficient can be measured easily using the same photometer and a flat white target. The luminance of the white target is measured directly (no windscreen) using the photometer to obtain a baseline

reading. Then the white target is measured through the windscreen to obtain the transmitted luminance. However, care must be taken to insure that the windscreen is shaded from as much ambient illumination as possible, and reflections should be minimized by using a flat black, light absorbing surface. Figure 3 shows the measurement geometry for a typical installed aircraft windscreen.

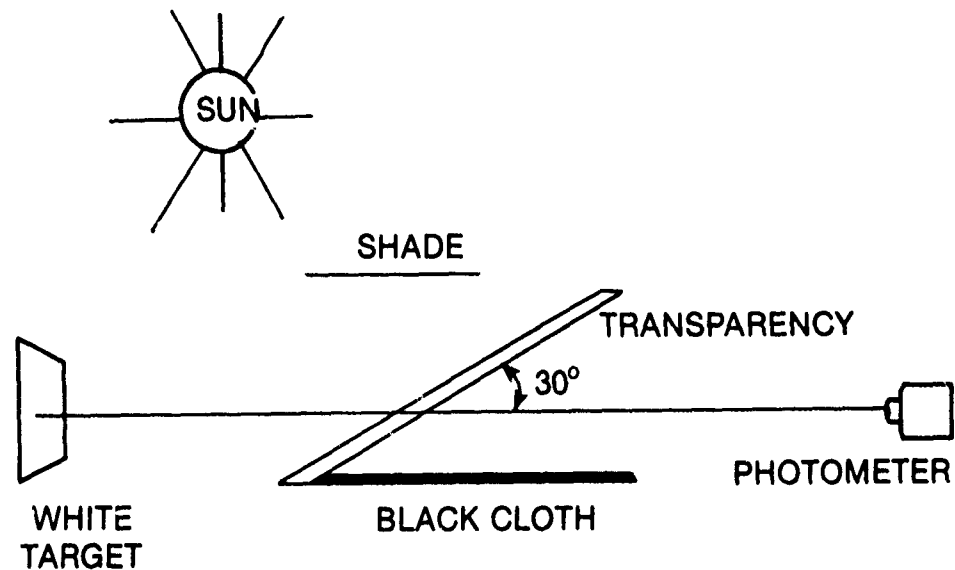

Figure 3. Geometry for measuring the transmission coefficient of the windscreen.

The windscreen is shaded to prevent the veiling luminance from contaminating the transmissivity measurement. The transmissivity is then simply the ratio of the photometer reading through the windscreen to the reading without the windscreen ($t = L/L'$). The transmissivity is a critical parameter in calculating the contrast loss through the transparency as will be described in the next section.

CONTRAST LOSS DUE TO HAZE

For simplicity of calculation, it will be assumed that the target of interest is a black area next to a white area similar to the targets described in the previous section for measuring haze index and transmissivity. The contrast of such a target is defined in equation (4).

$$Cl = \frac{W - B}{W + B} \quad (4)$$

where: Cl = contrast of target
W = luminance of the white area
B = luminance of the black area

If this same target is now viewed through a transparency that has some level of haze caused by ambient illumination, then the apparent contrast of this target will change. Two effects take place: first each luminance level within the target is reduced by the transmission coefficient of the transparency, and second a veiling luminance is added to both luminance levels of the target. The resulting apparent target luminances are therefore:

$$W' = Wt + L \tag{5}$$

and

$$B' = Bt + L \tag{6}$$

where:

W' = luminance of white area viewed through windscreen

B' = luminance of black area viewed through windscreen

t = windscreen transmissivity

L = veiling luminance

W = luminance of white area without windscreen

B = luminance of black area without windscreen

These values can be substituted into the general equation for contrast to obtain the contrast as viewed through the windscreen:

$$C2 = \frac{W' - B'}{W' + B'} = \frac{(Wt + L) - (Bt + L)}{(Wt + L) + (Bt + L)} \tag{7}$$

Equation (7) can be further reduced by dividing the numerator and denominator by "t" and by substituting equation (2) for the veiling luminance.

$$C2 = \frac{W - B}{W + B + 2EHi/t} \tag{8}$$

Note that the equation for C2 is similar to that for C1 with the exception of the extra term in the denominator. It is this term that describes the lowered contrast experienced when viewing through the transparency. Part of this term is sufficiently important that it should have its own identifying name. The value of H_i/t is a basic characteristic that depends only on the transparency material involved and not on the ambient conditions (E, or illumination). It is therefore ideally suited for comparing transparency haze effects of materials. For this reason the value of H_i/t is referred to as the "haze ratio":

$$\text{Haze Ratio} = H_r = \frac{\text{Haze index}}{\text{transmissivity}} = \frac{H_i}{t} \quad (9)$$

The haze ratio for each of several transparencies that have been measured both in the lab and in the field are provided in a later section.

Before deriving the equation for the contrast loss, it will be helpful if the equations for contrast are put in a slightly different form. First, let us define the amplitude of the contrast as half the difference between the white and black targets and, secondly, let us define the mean target luminance as half of the sum of the white and black targets. In equation form:

$$\text{Amplitude} = A = \frac{W - B}{2} \quad (10)$$

and

$$\text{Mean} = M = \frac{W + B}{2} \quad (11)$$

If (10) and (11) are substituted into equations (4) and (8) one obtains:

$$C1 = \frac{A}{M} \quad (12)$$

and

$$C2 = \frac{A}{M + EHi/t} \quad (13)$$

The loss in contrast is given in equation (14):

$$CL = \frac{C1 - C2}{C1} \quad (14)$$

where: CL = contrast loss
 C1 = target contrast viewed directly
 C2 = target contrast viewed through transparency

Substituting equations (12) and (13) into (14) one obtains:

$$CL = 1 - \frac{M}{M + EHi/t} \quad (15)$$

Equation (15) is the primary equation for predicting the resulting contrast loss for any mean target luminance and ambient illumination condition. It is particularly important to note that the result of equation (15) is independent of the target contrast but only depends on the average luminance of the target. Another important fact is that if the haze index is not zero then the contrast loss also depends explicitly on the transmission coefficient of the transparency. This is a significant result in that typically one does not expect a drop in transmissivity to cause a loss of contrast.

Figure 4 shows a graph demonstrating the loss of contrast due to different transmissivities. The transmissivities are: $t_1 = 0.90$ (glass windscreen), $t_2 = 0.70$ (plastic windscreen), $t_3 = 0.49$ (plastic windscreen with HUD) and $t_4 = 0.42$ (plastic windscreen plus LANTIRN HUD eyebrow).

Figures 5 through 8 graphically depict the effects of mean luminance, illumination and haze ratio on contrast loss for Low ($M = 200$ foot-lamberts), Medium ($M = 600$ foot-lamberts) and High ($M = 1000$ foot-lamberts) average target luminances.

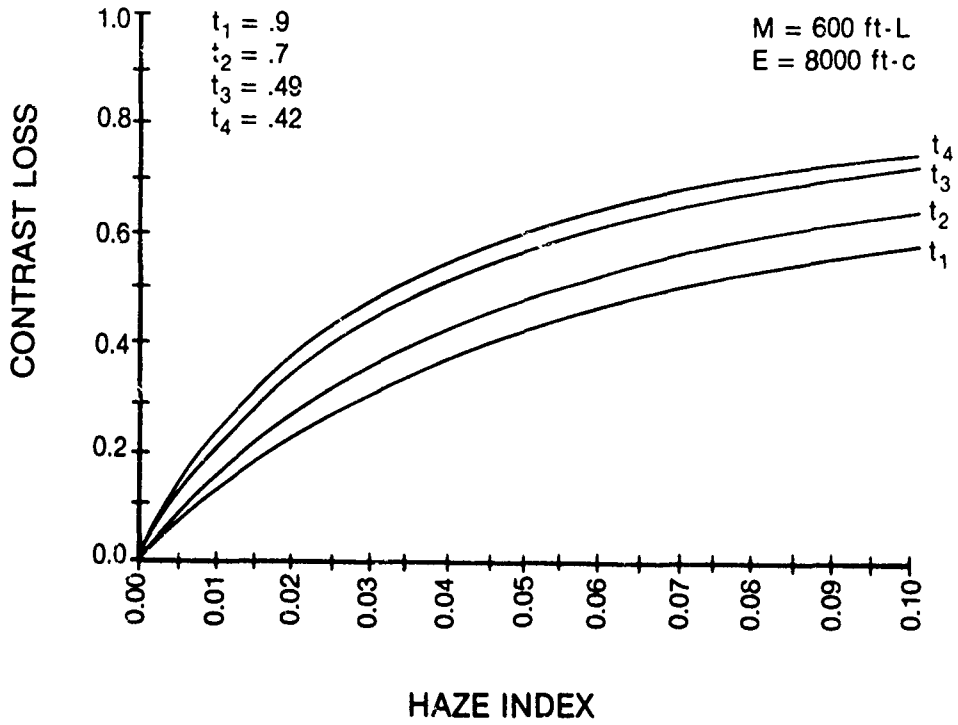

Figure 4. Contrast Loss for Different Transmissivities Versus Haze Index for a Sunny Day

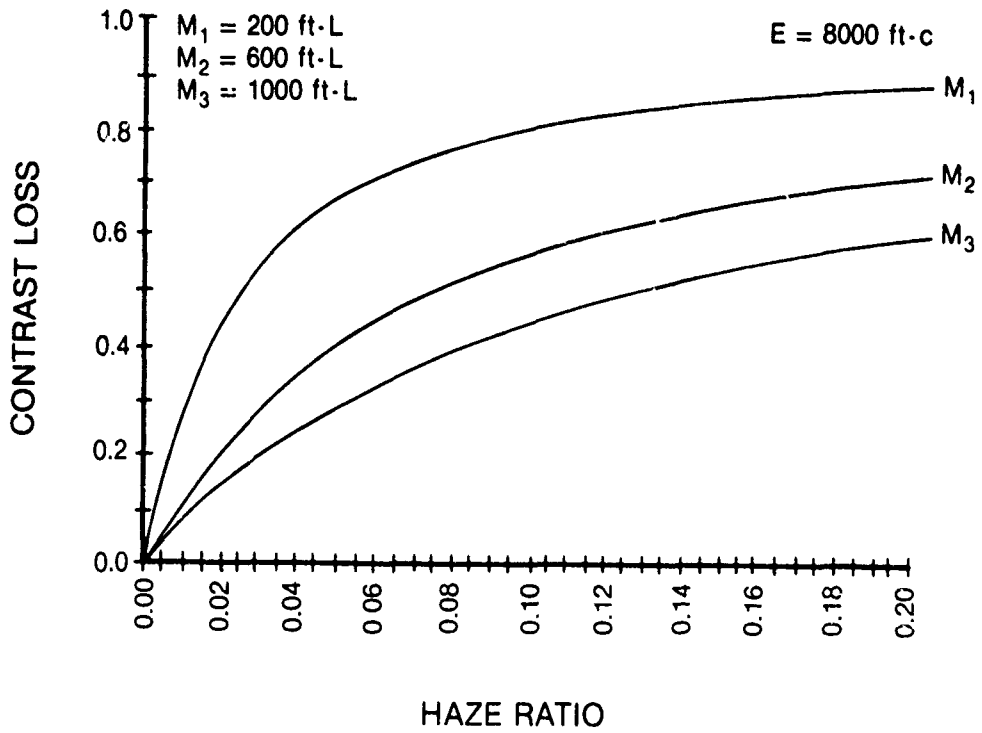

Figure 5. Contrast Loss Versus Haze Ratio for Bright Day Viewing Toward Sun

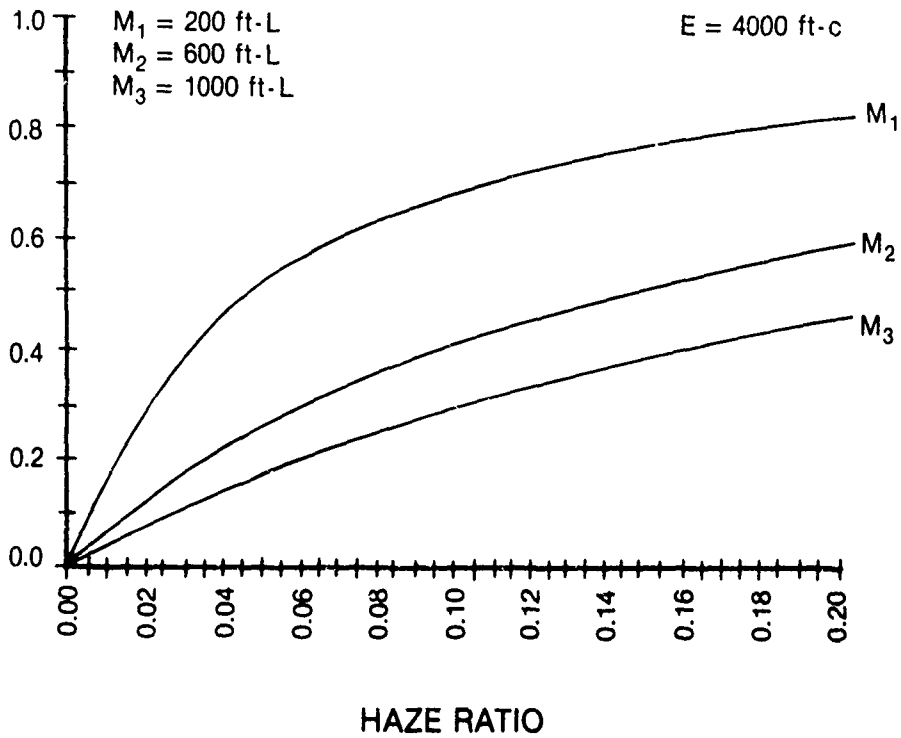

Figure 6. Contrast Loss Versus Haze Ratio for Bright Day Viewing at Moderate Angle From Sun

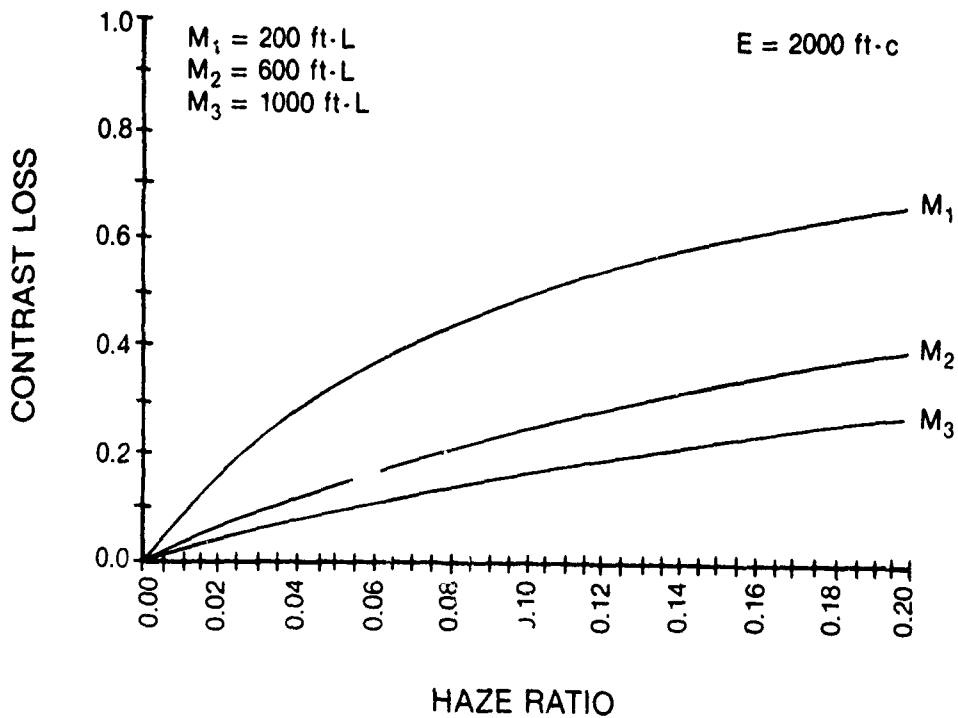

Figure 7. Contrast Loss Versus Haze Index for Bright Day Viewing at a Large Angle from the Sun

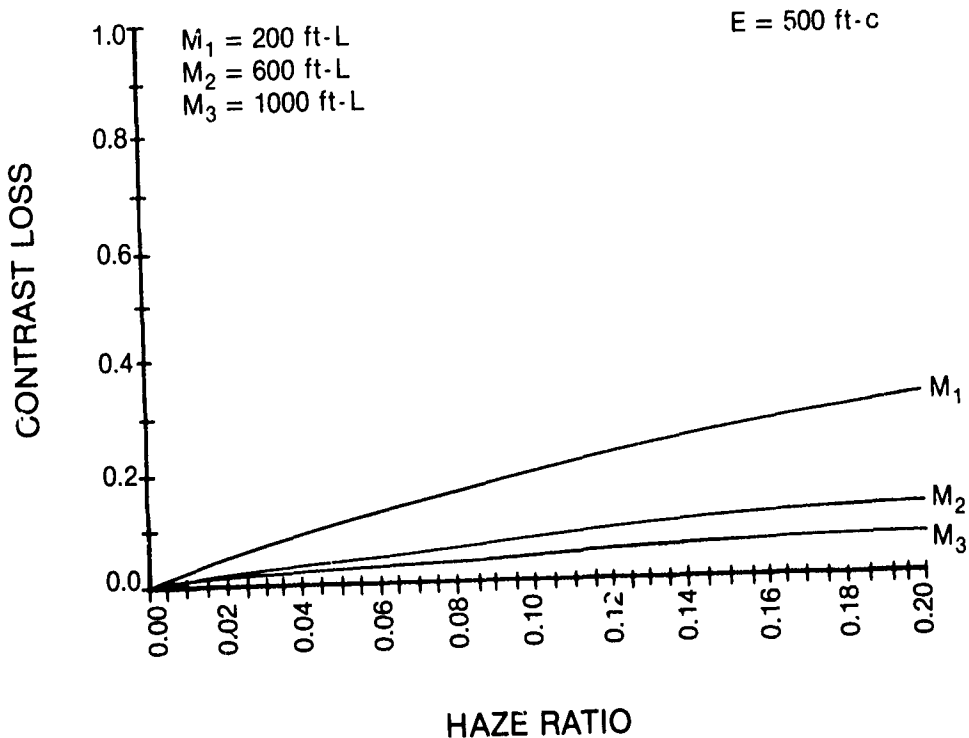

Figure 8. Contrast Loss Versus Haze Index for Bright Day Viewing Almost Directly Away from the Sun

HAZE MEASUREMENT TEST RESULTS

Figure 9 shows the field test kit that was assembled to make haze measurements of aircraft windscreens and HUDs. The kit consists of a black and white target hinged in the center for convenience, a hand-held photometer, a barium sulfate Lambertian surface, and a device for measuring the elevation of the sun. The kit was designed to make four measurements: actual contrast loss, haze index, ambient illumination and transmissivity. The latter three measurements were used to calculate the predicted contrast loss using equation (15) to compare with the measured actual contrast loss. It was not always possible to measure the transmissivity due to lack of a convenient means of shading the transparency from direct sunlight. For data sets where the transmissivity was not measured directly, the transmissivity was estimated from previous lab data for the type of transparency

involved. The following several data tables show the results of measurements made on several windscreens and HUDs. Estimated transmissivity data is so noted.

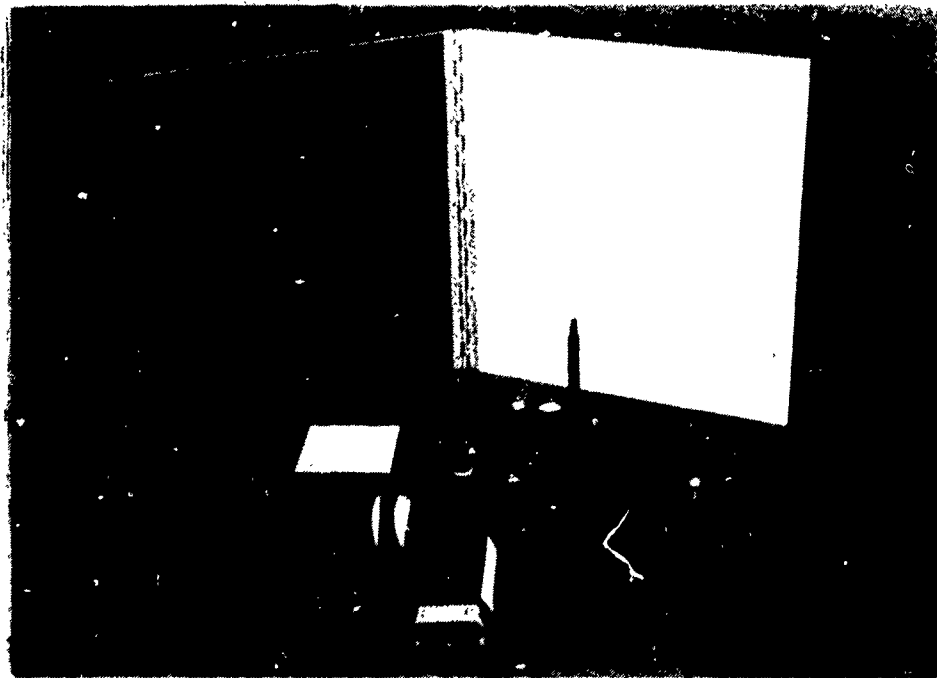

Figure 9. The Contrast Loss Measurement Kit

The measurement kit was used to measure the contrast loss and haze index of several uninstalled F-111 windscreens at Wright-Patterson AFB, OH, in order to test the measurement procedure. In each case the contrast loss was measured directly, and then the haze index, ambient illumination and transmissivity measurements were used to calculate the predicted contrast loss using equation (15). The results of some of these measurements are shown in Tables 1 and 2.

Table 1 shows data from a used plastic windscreen and Table 2 shows data from a used glass windscreen. It is quite apparent from these data that the plastic windscreen suffers from a considerably higher level of haze than does the glass windscreen.

Table 1. F-111 Plastic Windscreen Lab Measurements:
 Haze Index and Loss of Contrast vs Sun Elevation

| Sun elev. | 31 deg | 46 deg | 48 deg | 50 deg |
|-----------------|-----------|-----------|-----------|-----------|
| Calculated loss | 60.5% | 54.5% | 50.6% | 50.1% |
| Measured loss | 65.9% | 60.0% | 59.3% | 59.8% |
| Percent error | 8.2% | 9.1% | 14.7% | 16.2% |
| Haze index * | .0621 | .0403 | .0360 | .0357 |
| Haze Ratio | .1170 | .0832 | .0661 | .0674 |
| Illumination | 4059 ft-c | 5884 ft-c | 6234 ft-c | 6336 ft-c |
| Mean target lum | 311 ft-L | 405 ft-L | 403 ft-L | 425 ft-L |
| Measured trans | .530 | .485 | .544 | .530 |

* Units are ft-L/ft-c.

Table 2. F-111 Glass Windscreen Measurements:
 Haze Index and Contrast Loss Repeatability

| Test trial: | #1 | #2 | #3 | Mean | Standard Dev |
|-------------------|----------|----------|----------|-------|--------------|
| Calculated loss | 16.2% | 14.9% | 14.5% | 14.7% | 0.2% |
| Measured loss | 15.7% | 17.3% | 14.8% | 15.9% | 1.3% |
| Percent error | 3.1% | 13.7% | 2.0% | N/A | N/A |
| Haze index * | .0055 | .0052 | .0047 | .0051 | .0004 |
| Haze ratic | .0112 | .0112 | .0106 | .0110 | .0003 |
| Mean target lum. | 425 ft-L | 425 ft-L | 422 ft-c | N/A | N/A |
| Illumination ft-c | 6658 | 6599 | 6789 | N/A | N/A |
| Measured trans. | 0.446 | 0.461 | 0.448 | 0.452 | 0.008 |

* Units are ft-L/ft-c.

Note: sun elevation = 50 deg.

The predictive capability of the haze index model appears reasonable with errors between predicted and measured values of contrast loss ranging from 2.0% to 16.2%. Using this technique, the measurement kit was used to determine the contrast loss caused by gun gas residue on A-10 windscreens. Two aircraft were measured before and after firing the cannon. The contrast loss and haze index were measured on each quarter panel (side windscreen) and through the central windscreen and HUD. The following tables are a sample of the data taken at Nellis AFB, NV and Myrtle Beach AFB, NC.

Table 3. Contrast Loss and Haze Index Measurements
 for A-10 Gun Gas Residue Tests (A/C #945 with clean windscreen)

| Test Item | Right w/s | Left w/s | Center HUD |
|------------------|-----------|-----------|------------|
| Calculated loss | *32.0% | *33.1% | **67.0% |
| Measured loss | 30.4% | 31.1% | 80.8% |
| Percent error | -5.3% | -6.6% | 17.1% |
| Haze index @ | .0140 | .0141 | .0459 |
| Haze ratio | *.0200 | *.0201 | **0.0918 |
| Illumination | 8935 ft-c | 8935 ft-c | 8789 ft-c |
| Mean target lum. | 380 ft-L | 361 ft-L | 398 ft-L |

@ Units are ft-L/ft-c.

* Based on estimated transmissivity of $t=0.7$.

** Based on estimated transmissivity of $t=0.5$.

Table 4. Contrast Loss and Haze Index Measurements
 for A-10 Gun Gas Residue Test (A/C #945 after cannon firing)

| Test item | Right w/s | Left w/s | Center HUD |
|------------------|-----------|-----------|------------|
| Calculated loss | *44.8% | *42.6% | **70.1% |
| Measured loss | 45.0% | 43.4% | 82.8% |
| Percent error | 0.4% | 1.9% | 15.4% |
| Haze index @ | .0253 | .0219 | .0441 |
| Haze ratio | *.0361 | *.0313 | **0.0881 |
| Illumination | 8701 ft-c | 8614 ft-c | 8731 |
| Mean target lum. | 383 ft-L | 363 ft-L | 328 ft-L |

@ Units are ft- /ft-c.

* Based on estimated transmissivity of $t=0.7$.

** Based on estimated transmissivity of $t=0.5$.

A comparison of Tables 3 and 4 clearly shows the increased loss of contrast due to the gun gas residue. The measurement technique proved to be highly effective in quantifying the effect of the gun gas residue. Additionally, Tables 3 and 4 show that the predictive equation for contrast loss based on the haze index works quite well with the exception of the HUD measurements. It is highly probable that the estimated HUD transmissivity of 0.5 was too high resulting in lower calculated contrast losses than those measured.

The haze measurement kit was also used to measure two F-16 LANTIRN HUDs, an older version and a newer version, to determine the level of contrast loss that could be expected due to the HUD combiner. The two HUDs were measured using sunlight with an elevation angle of about 30 degrees. Table 5 shows the results of these measurements.

Table 5. Contrast Loss and Haze Index Measurements in LANTIRN HUD Combiners

| HUD: | #004 (old) | | #005 (new) | |
|-----------------|------------|-----------|------------|-----------|
| | Eyebrow | Center | Eyebrow | Center |
| ----- | ----- | ----- | ----- | ----- |
| Calculated loss | 67.9% | 38.7% | 70.3% | 29.3% |
| Measured loss | 66.8% | 38.3% | 73.4% | 29.5% |
| Percent error | -1.7% | -1.0% | 4.2% | 0.7% |
| Haze index * | .0444 | .0159 | .0521 | .0106 |
| Haze ratio | .0887 | .0265 | .0868 | .0152 |
| Illumination | 8001 ft-c | 8001 ft-c | 7650 ft-c | 7650 ft-c |
| Mean target lum | 336 ft-L | 336 ft-L | 281 ft-L | 281 ft-L |
| Estimated trans | 0.500 | 0.600 | 0.600 | 0.700 |
| ----- | ----- | ----- | ----- | ----- |

* Units are ft-L/ft-c.

The low percentage errors between predicted and measured contrast loss shown in Table 5 demonstrate the powerful potential of the haze index model. Also, it should be noted that the ambient conditions changed somewhat between measuring the old and the new HUD. Since these different conditions (ambient illumination and mean target luminance) affect the measured contrast loss results, it is important to compare the two HUDs on the basis of the haze ratio which is independent of these ambient conditions. This again demonstrates the strength and utility of the haze index model. Equation (15) could be used in conjunction with the haze ratio to calculate the contrast loss of the two HUDs for the same ambient conditions in order to facilitate direct comparisons between the two HUDs. Looking at the visibility ratio data in Table 5 it is apparent that both HUDs are almost equivalent in the eyebrow area but the new HUD is better (lower haze ratio) in the center area.

Table 6 shows data that were obtained at Edwards AFB, CA on an F-16 aircraft canopy and LANTIRN HUD. These data demonstrate the interaction between the HUD and the canopy in causing significant loss of contrast.

Table 6. F-16 Windscreen and LANTIRN HUD
 Contrast Loss and Haze Index Measurements

| Test item: | #1 | #2 | #3 | #4 | #5 |
|-----------------|-------|--------|-------|-------|--------|
| Calculated loss | 35.7% | 60.2% | 28.0% | 75.8% | 58.5% |
| Measured loss | 35.3% | 52.2% | 26.5% | 76.2% | 52.0% |
| Percent error | -1.0% | -15.5% | -5.7% | 0.4% | -12.7% |
| Haze index * | .0174 | .0366 | .0122 | .0485 | .0287 |
| Haze ratio | .0268 | .0732 | .0188 | .1514 | .0683 |
| Estimated trans | .650 | .500 | .650 | .320 | .420 |

* Units are ft-L/ft-c. Notes: illumination = 8994 ft-c; mean target luminance = 434 ft-L; test item #1 = windscreen only; #2 = HUD eyebrow only; #3 = HUD center only; #4 = windscreen plus eyebrow and #5 = windscreen plus HUD center.

The preceding tables have provided examples of the utility and predictive power of the haze index model. The following table (Table 7) provides a listing of haze indices, haze ratios and transmissivities that have been obtained for various transparencies. These numbers represent individual transparencies, and are not meant to describe each class of transparencies. To perform the latter, a larger database must be established.

Table 7. Typical Values of Haze Index,
 Transmissivity and Haze Ratio for Various Transparencies

| Transparencies | Haze Index* | Haze Ratio* | Trans- missivity | Crew's Comments |
|-----------------------|----------------|----------------|---------------------|--------------------|
| ----- | | | | |
| F-111 glass w/s | .0050 | .0110 | .45 - .70 | Good |
| F-111 plastic w/s | .0400 | .0800 | .50 - .70 | Marginal |
| LANTIRN HUD eyebrow | .0450 | .0850 | .50 - .60 | Marginal |
| LANTIRN HUD center | .0130 | .0200 | .60 - .70 | Good |
| F-16 w/s | .0230 | .0350 | .55 - .75 | OK |
| F-16 w/s with LANTIRN | | | | |
| HUD--eyebrow | .0480 | .1500 | .30 - .35 | Poor |
| HUD center | .0330 | .0780 | .40 - .50 | Marginal |
| A-10 plastic w/s | .0220 | .0300 | .55 - .70 | OK |
| A-10 w/s with | | | | |
| severe residue | .1100 | .1580+ | .45 - .60 | Unacceptable |
| A-10 w/s & HUD | .0420 | .0800 | .35 - .45 | Poor |
| ----- | | | | |

* Units are ft-L/ft-c.

By using the haze values given in Table 7 and the graphs provided in an earlier section of this report, it is possible to estimate the contrast loss that will be incurred for several ambient illumination and target luminance conditions.

In general, studies that have been performed to determine the interaction of contrast and angular size of targets on detection performance result in a functional relationship between angular subtense of target and target to background contrast. Many of these studies have been done by Blackwell and others. Their results can be shown to be related by the equation:

$$\sigma' = F(c) \quad (16)$$

Where:

- a = Angular subtense of target at detection
- c = Contrast

Since values of a are typically very small (less than one degree), the following equation relates angular subtense to range:

$$R = S / \tan(a) \quad (17)$$

Where:

- R = Range to target
- S = Size of target
- a = Angular subtense of target

The loss of detection range due to any degrading effect is defined as:

$$LR = (R_1 - R_2) / R_1 = 1 - R_2/R_1 \quad (18)$$

Where:

- LR = Fractional loss of range (x100 for percent)
- R₁ = "Normal" Detection Range
- R₂ = Detection Range after degradation

By combining equations (16), (17) and (18) we obtain:

$$L_R = 1 - [\tan(F(c_1)) / \tan(F(c_2))] \quad (19)$$

Equation (13) can be modified to:

$$C_2 = \frac{A/M}{1 + (E*Hi/Mt)} = \frac{C_1}{1 + (E*Hi/Mt)} \quad (20)$$

Combining Equations (19) and (20), we obtain the general result:

$$L_R = 1 - [\text{Tan } (F(c_1)) / \text{Tan } (F(c_1 * (\frac{1}{1 + (E*Hi/Mt)})))] \quad (21)$$

Equation (21) can then be used with any function that describes the angular subtense of a target at detection versus its contrast.

To obtain a specific version of equation (21), a study was performed to collect data on the angular subtense required to detect a dark circular disk on a light background. Figure 10 shows the results of this study with a best-fit power curve:

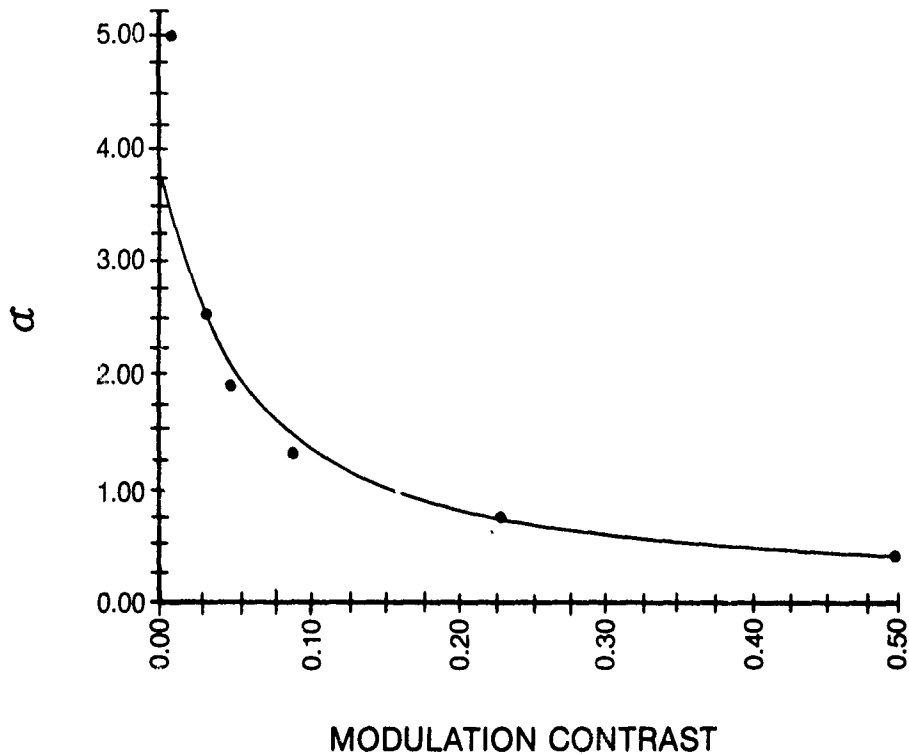

Figure 10, Angular Subtense at Detection versus Contrast for a Dark Circular Disk on a Light Background

The best fit curve shown in Figure 10 makes an excellent fit with the data ($r = 0.99$), and provides a convenient functional relationship between angular size and contrast as shown in equation (22):

$$\alpha = 0.400 C^{-0.361} \quad (22)$$

where:

- α = Angular Subtense in Minutes of arc
- C = Modulation Contrast

Equation (22) can be changed to express α in radians as follows:

$$\alpha = 0.000116 C^{-0.361} \quad (23)$$

where:

α = Angular Subtense in Radians

C = Modulation Contrast

Substituting equation (23) into equation (21) and making a small angle approximation to eliminate the tangent function, we obtain:

$$L_R = 1 - \frac{0.000116 * C^{-0.361}}{0.000116 (C * (\frac{1}{1 + (E*Hi/Mt)}))^{-0.361}} \quad (24)$$

Which reduces to:

$$L_R = 1 - (1 + (E*Hi/Mt))^{-0.361} \quad (25)$$

Note that the contrast terms cancel, and the fractional loss of range (L_R) does not depend on the target to background contrast. This is due to the particular functional form of the angular subtense versus contrast equation. It should also be noted that this equation is valid only for values of contrast ranging from about 0.03 to 1.00 (3% to 100%) since that was the range of contrasts of the circular disks used to obtain equation (22).

It is also possible to derive an equation for detection range using equations (17), (20) and (23):

$$R = \frac{S}{\tan \left\{ 0.000116 \left[C \left(\frac{1}{1 + (E \cdot H_i / M_t)} \right)^{-0.361} \right] \right\}} \quad (26)$$

Equations (25) and (26) provide the foundation for predicting target detection performance as it is affected by windscreen haze, windscreen transmissivity, ambient illumination, mean target luminance, target contrast and target size. The series of graphs in the Appendix show these equations plotted for a number of typical conditions.

CONCLUSIONS

It should be quite apparent from the preceding material that the haze index model and the measurement procedures and field kit described provide a nearly ideal approach to quantifying and predicting contrast losses in aircraft transparencies due to light scatter. The general technique can be used in the lab or in the field on almost any type of transparency. Although Windscreens and HUDs have been the primary transparencies of interest in this report, the technique and theory applies equally well to visors, chemical defense masks, eyeglasses, and other transparent materials through which an observer is expected to see. Using these methods will not only provide a field useable objective means to accurately measure the "haze" in a transparency, but also predict the loss in visual target detection range created by that transparency under specific conditions.

APPENDIX

The effect of Windscreen Optics on Visual Detection Range for Typical Daylight Conditions.

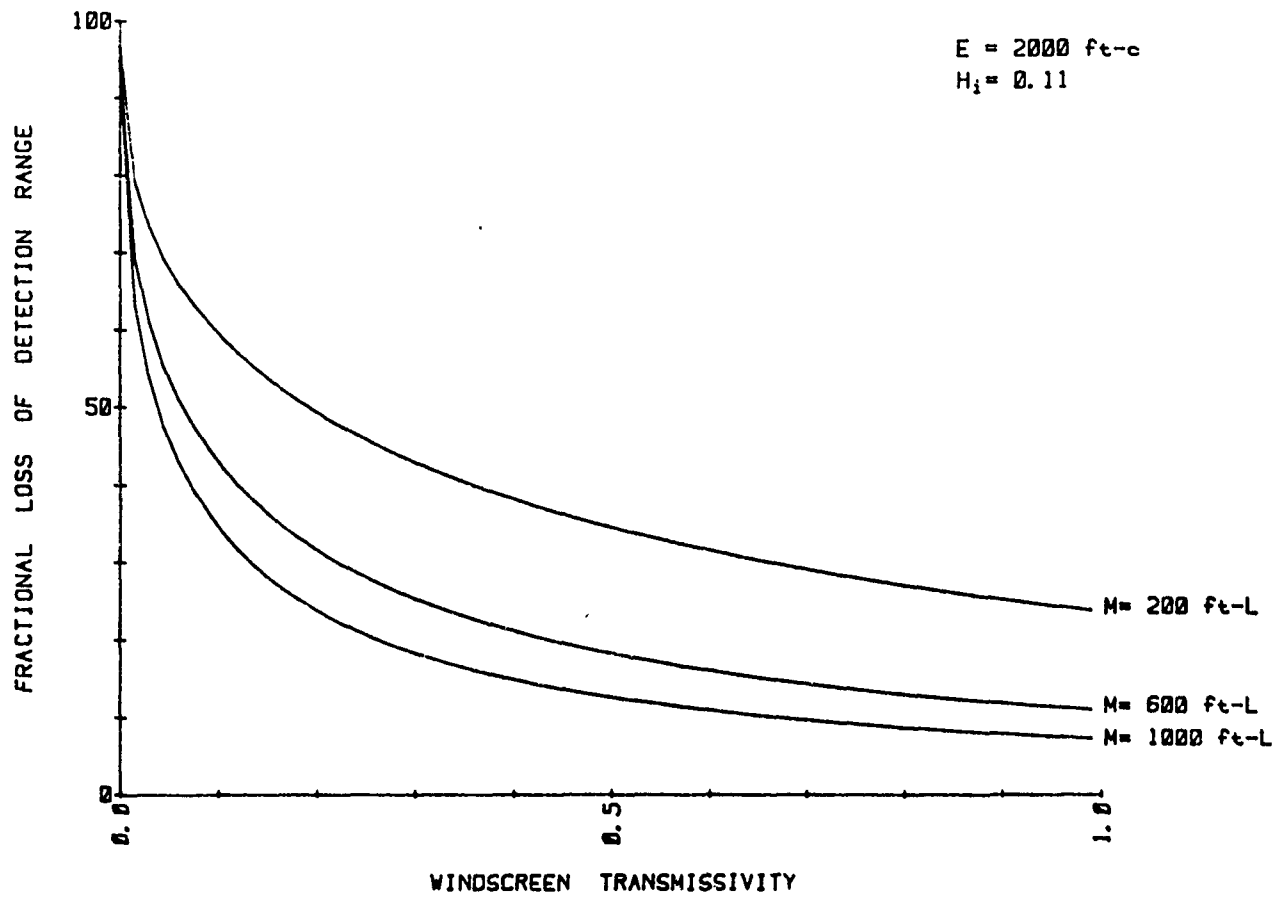

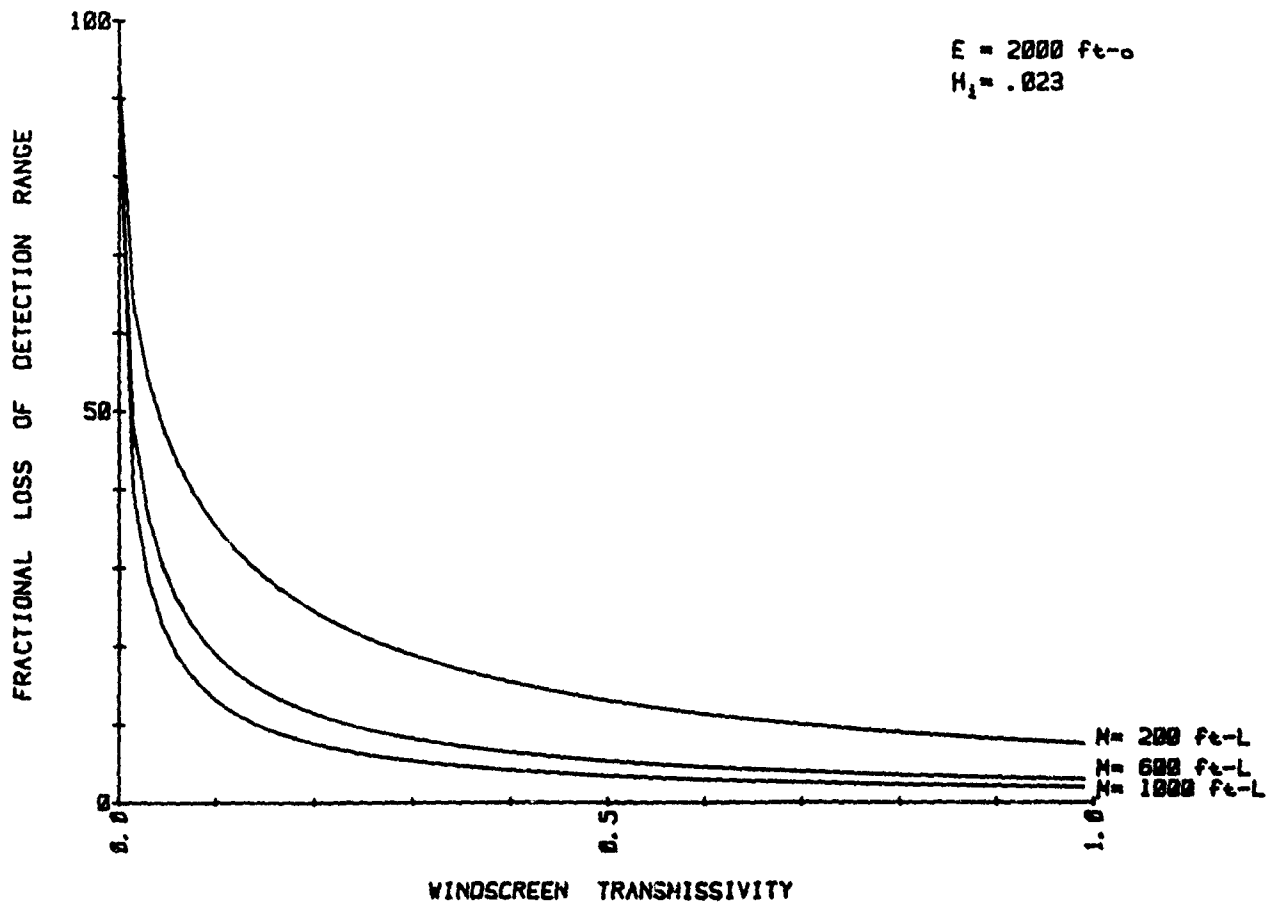

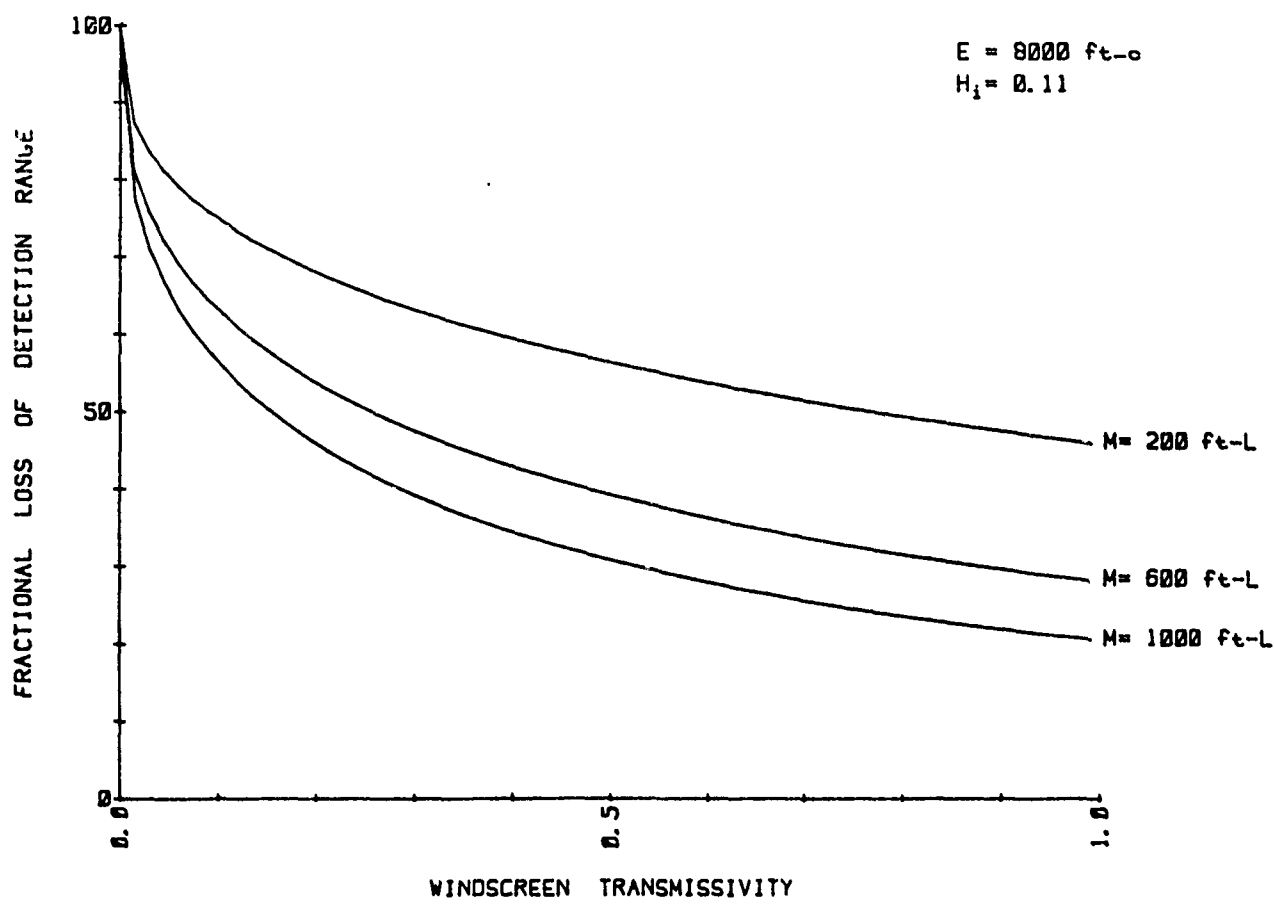

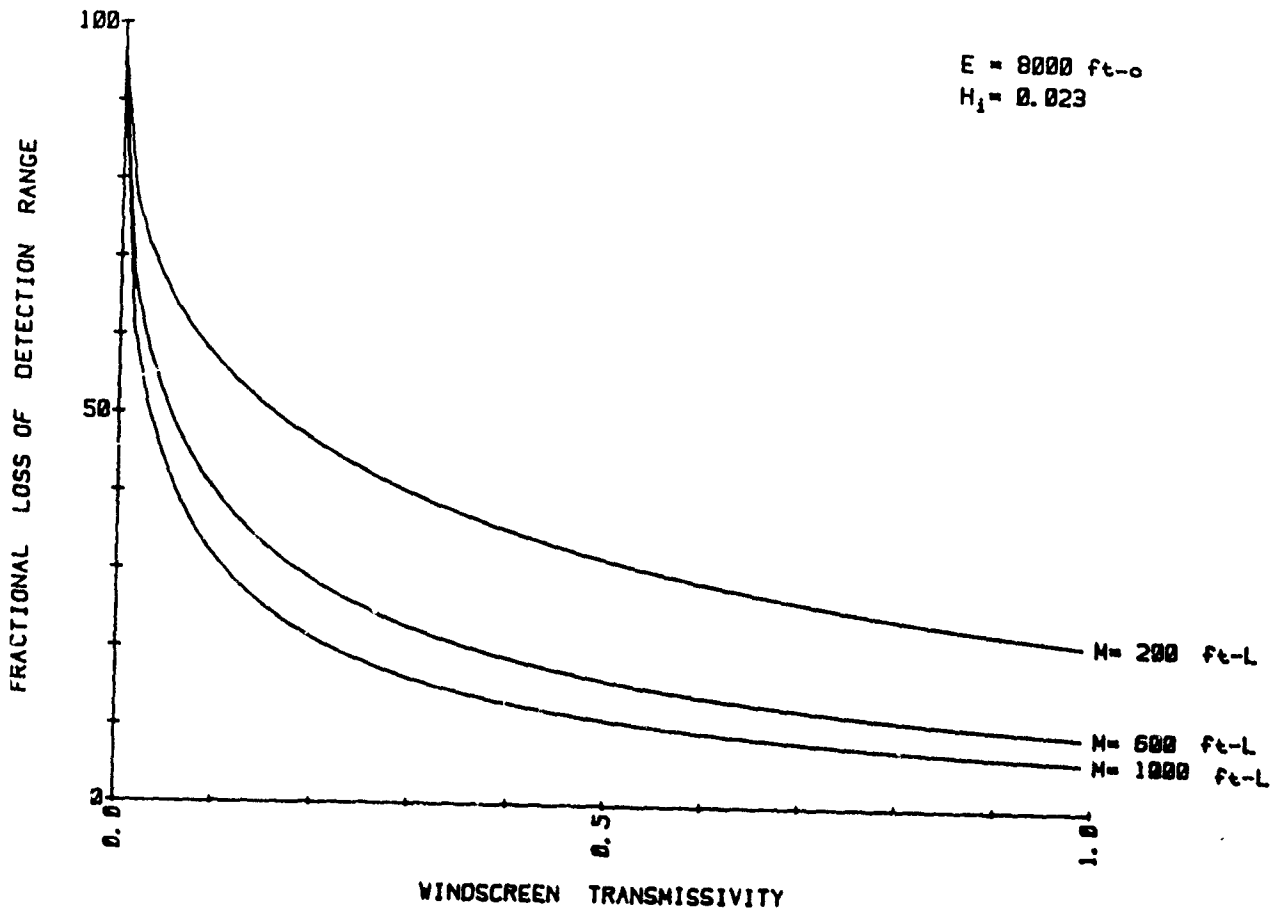

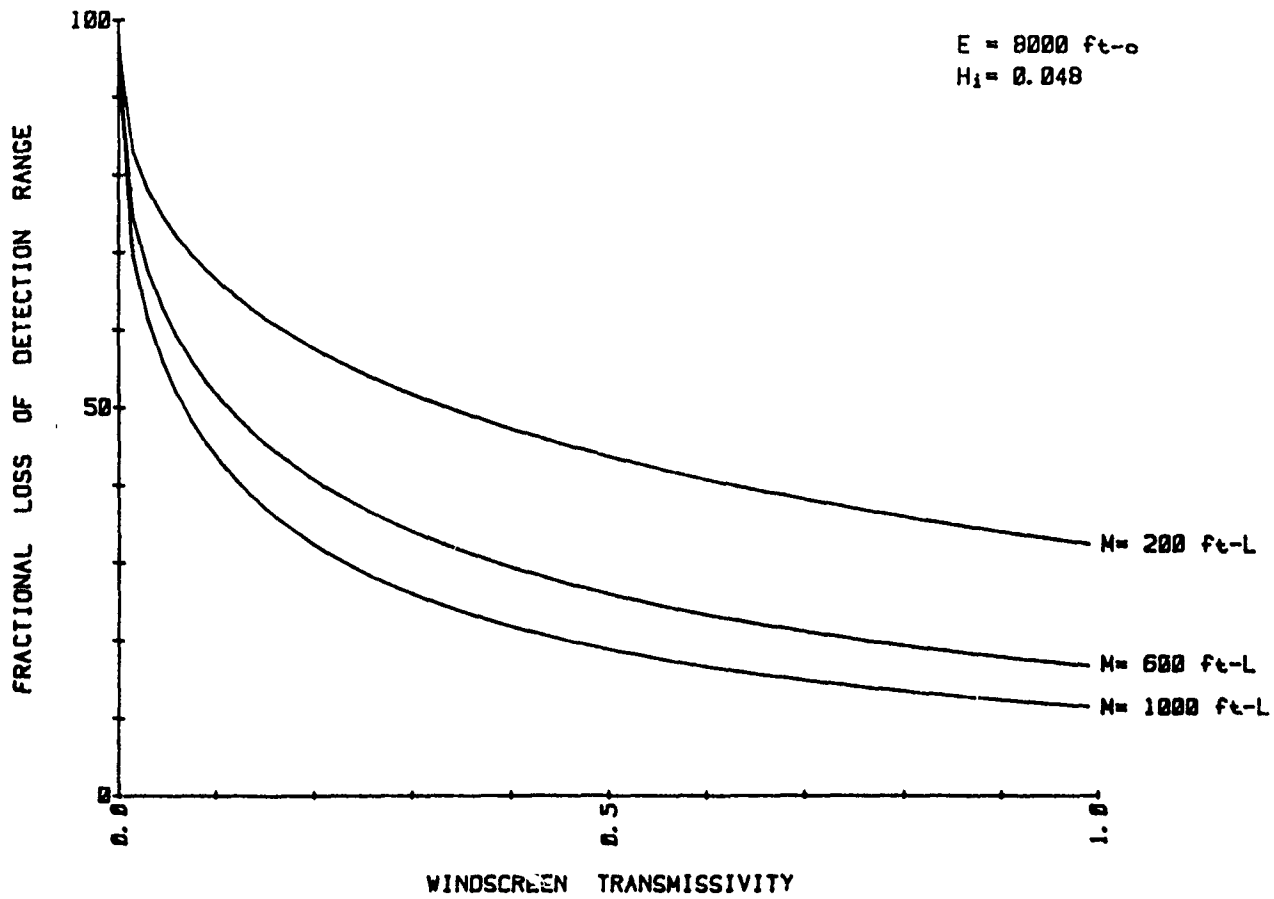

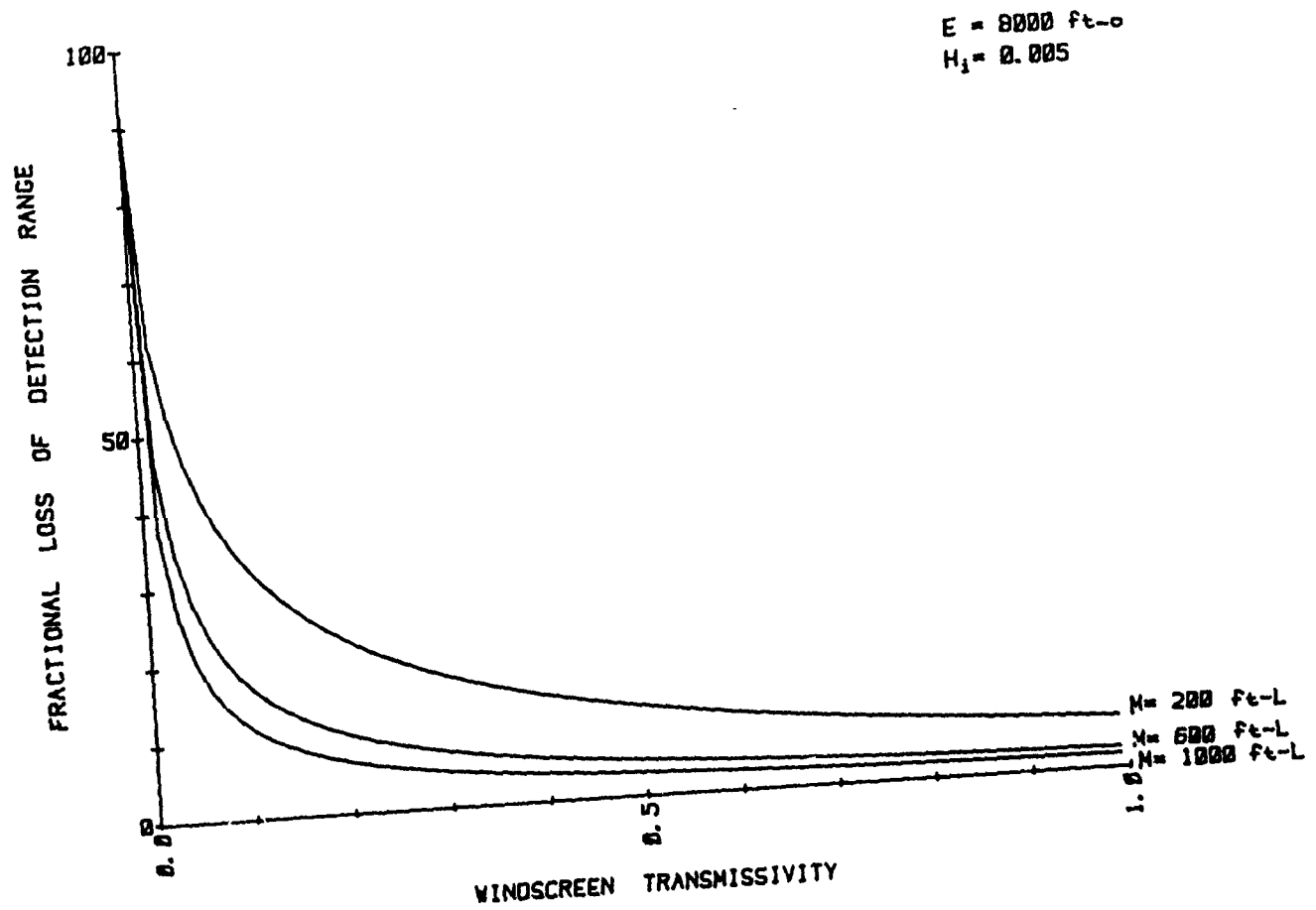

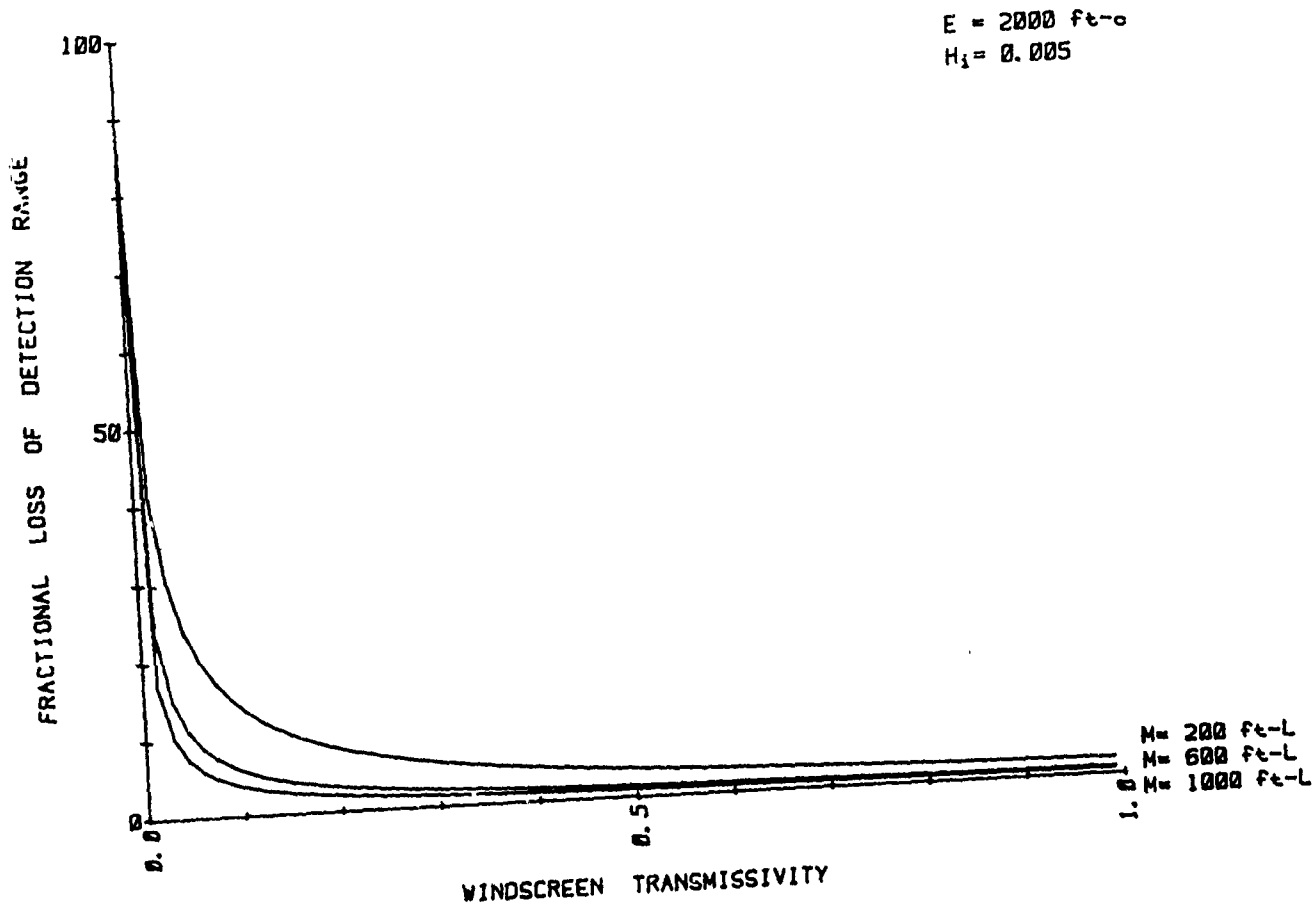

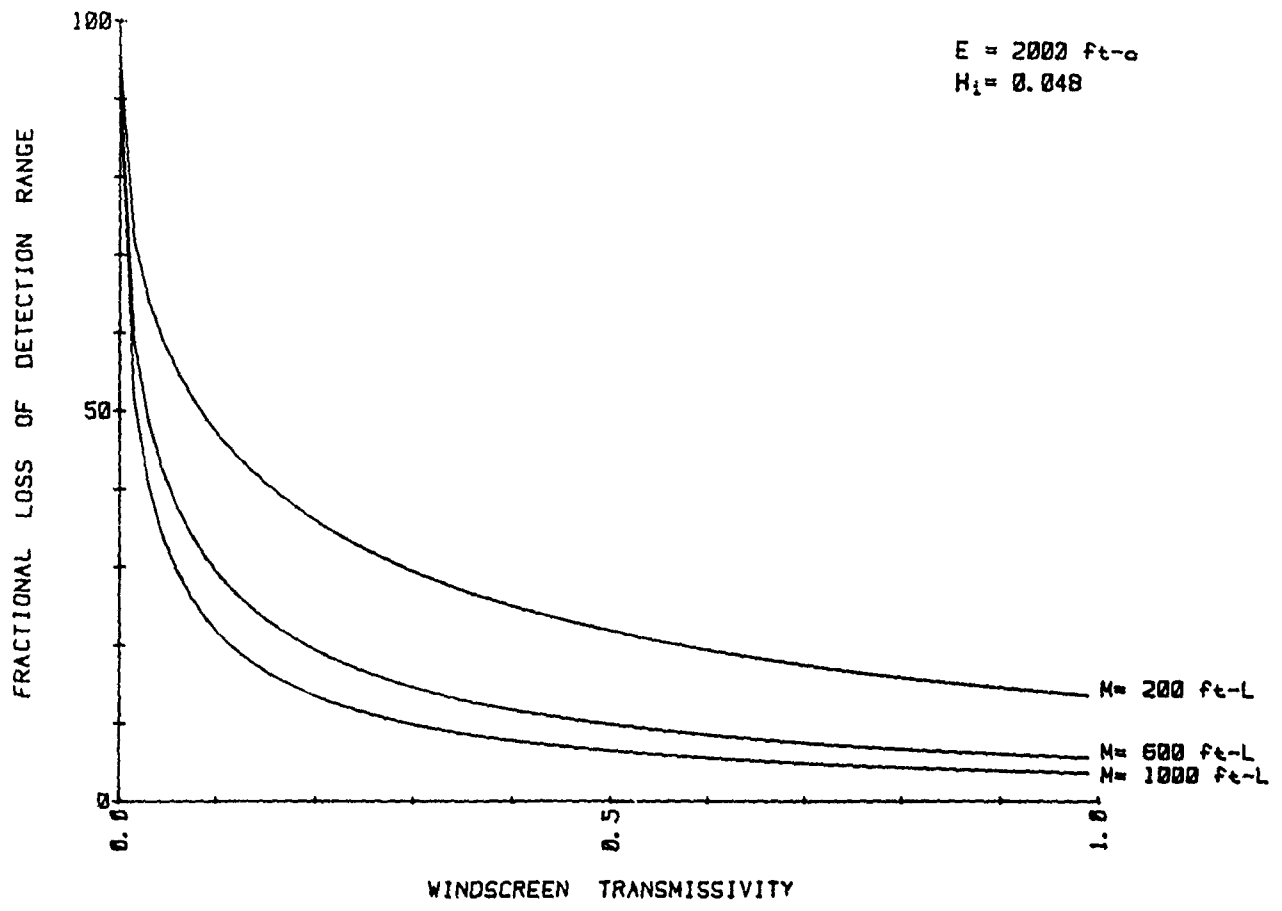

REFERENCES

ASTM D1003-6170, Haze and Luminous Transmittance for Transparent Plastics, March 1975.

Federal Test Method No. 3022, Plastics, Methods of Testing

Blackwell, H. Richard, "Contrast Thresholds of the Human Eye", Journal of the Optical Society of America, Vol 36, No. 11, November 1944.

Genco, Louis V., Lt. Col, USAF, Aircraft Transparencies and Aircrew Visual Performance 1984, AFAMRL-TR-84-005, Air Force Aerospace Medical Research Laboratory, Aerospace Medical Division, Air Force Systems Command, Wright-Patterson AFB, OH 45433.

Kama, William M, and Louis V. Genco O.D., Lt. Col, USAF, The Effect of Haze on an Operator's Visual Field and His Target Detection Performance, 1983, AFAMRL-TR-83-066, Air Force Aerospace Medical Research Laboratory, Aerospace Medical Division, Air Force Systems Command, Wright-Patterson AFB, OH 45433.

Wulfeck, J.W., et al., November 1958, Vision in Military Aviation, WADC TR 58-399 (AD 207780), Wright Air Development Center, Wright-Patterson AFB, Ohio 45433.