

AD-A252 332



AL-TR-1992-0062

ARMSTRONG LABORATORY

ADAPTING THE ADAM MANIKIN TECHNOLOGY FOR INJURY PROBABILITY ASSESSMENT

James H. Raddin, Jr., MD
 William R. Scott, PhD
 John B. Bomar, PhD
 Harry L. Smith, MD, PhD
 James V. Benedict, MD, PhD
 Whitman E. McConnell, MD
 Patricia K. Perret
 Herbert M. Guzman

DTIC
 ELECTE
 JUL 0 1 1992
 S B D

92-17112

BIODYNAMIC RESEARCH CORPORATION
 9901 I.H. 10 WEST, SUITE 1000
 SAN ANTONIO, TEXAS 78230

FEBRUARY 1992

FINAL REPORT FOR THE PERIOD JULY 1991 TO FEBRUARY 1992

Approved for public release; distribution is unlimited.

92 6 29

104

AIR FORCE SYSTEMS COMMAND
 WRIGHT-PATTERSON AIR FORCE BASE, OHIO 45433-6673

NOTICES

When US Government drawings, specifications, or other data are used for any purpose other than a definitely related Government procurement operation, the Government thereby incurs no responsibility nor any obligation whatsoever, and the fact that the Government may have formulated, furnished, or in any way supplied the said drawings, specifications, or other data, is not to be regarded by implication or otherwise, as in any manner, licensing the holder or any other person or corporation, or conveying any rights or permission to manufacture, use or sell any patented invention that may in any way be related thereto.

Please do not request copies of this report from the Armstrong Laboratory. Additional copies may be purchased from:

National Technical Information Service
5285 Port Royal Road
Springfield VA 22161

Federal Government agencies and their contractors registered with Defense Technical Information Center should direct requests for copies of this report to:

Defense Technical Information Center
Cameron Station
Alexandria VA 22314

TECHNICAL REVIEW AND APPROVAL

AL-TR-1992-0062

This report has been reviewed by the Office of Public Affairs (PA) and is releasable to the National Technical Information Service (NTIS). At NTIS, it will be available to the general public, including foreign nations.

This technical report has been reviewed and is approved for publication.

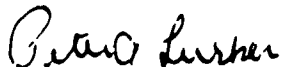

PETER A. LURKER, Lt Col, USAF, BSC
Acting Director
Biodynamics and Biocommunications Division
Armstrong Laboratory

REPORT DOCUMENTATION PAGE			Form Approved OMB No 0704-0188	
Public reporting burden for this collection of information is estimated to average 1 hour per response, including the time for reviewing instructions, searching existing data sources, gathering and maintaining the data needed, and completing and reviewing the collection of information. Send comments regarding this burden estimate or any other aspect of this collection of information, including suggestions for reducing this burden, to Washington Headquarters Services, Directorate for Information Operations and Reports, 1215 Jefferson Davis Highway, Suite 1204, Arlington, VA 22202-4302, and to the Office of Management and Budget, Paperwork Reduction Project (0704-0188), Washington, DC 20503.				
1. AGENCY USE ONLY (Leave blank)	2. REPORT DATE 02-05-92	3. REPORT TYPE AND DATES COVERED Final 5 Jul 91 - 19 Feb 92		
4. TITLE AND SUBTITLE Adapting the ADAM Manikin Technology for Injury Probability Assessment			5. FUNDING NUMBERS PR 3005 PR 65502F 3005B109	
6. AUTHOR(S) J.H. Raddin, Jr., M.D.; W.R. Scott, Ph.D.; J.B. Bomar, Ph.D.; H.L. Smith, M.D., Ph.D.; J.V. Benedict, M.D., Ph.D.; W.E. McConnell, M.D.; P.K. Perret; M.H. Guzman				
7. PERFORMING ORGANIZATION NAME(S) AND ADDRESS(ES) Biodynamic Research Corporation 9901 IH 10 West Suite 1000 San Antonio, TX 78230			8. PERFORMING ORGANIZATION REPORT NUMBER F41624-91-C-6003	
9. SPONSORING / MONITORING AGENCY NAME(S) AND ADDRESS(ES) Armstrong Laboratory Biodynamics and Biocommunications Division AL/CFBV Wright-Patterson AFB, OH			10. SPONSORING / MONITORING AGENCY REPORT NUMBER AL-TR-1992-0062	
11. SUPPLEMENTARY NOTES				
12a. DISTRIBUTION / AVAILABILITY STATEMENT Approved for public release; distribution is unlimited.			12b. DISTRIBUTION CODE A	
13. ABSTRACT (Maximum 200 words) An approach is presented for the general definition of regional injury human impact criteria with particular attention to the articulated ADAM test manikin and the escape environment. A review of literature and ejection injury data confirmed that injuries of greatest interest were those to the head, neck, thoracolumbar spine, and proximal extremities. A substantial literature review was pursued, demonstrating consistent findings of strain rate-dependent injury behavior over a wide range of injury types and body regions. Building upon previous work on the Dynamic Response Index, a comprehensive proposal is advanced for the conceptual definition of regional viscoelastic strain models for injury probability assessment. The proposed form for a head injury criterion assesses both translation and angular acceleration stress in terms of viscoelastic strain while also incorporating a means to account for their interaction. The neck criterion is based on a viscoelastic strain model of axial stress in association with shear and moment effects. The thoracolumbar spine criterion also proposes an extension of the prior DRI approach to account for interacting effects of moments and shear stresses. Approaches for the proximal extremities are formulated in a similar fashion. An outline is proposed for quantitative formulation and validation of the concept.				
14. SUBJECT TERMS Human impact injury criteria; impact probability assessment; viscoelastic strain model; head, neck, spine, proximal extremities.			15. NUMBER OF PAGES 253 pp.	
			16. PRICE CODE	
17. SECURITY CLASSIFICATION OF REPORT Unclassified	18. SECURITY CLASSIFICATION OF THIS PAGE Unclassified	19. SECURITY CLASSIFICATION OF ABSTRACT Unclassified	20. LIMITATION OF ABSTRACT UL	

ACKNOWLEDGMENTS

The members of the research team express their deep appreciation to the many individuals and organizations making contributions to this research program. Without the timely assistance given so generously by everyone, the research program and this report could not possibly have been accomplished.

The cooperation and support of the Air Force Inspection and Safety Center, Norton AFB, California, and especially Mr. Robert L. Campbell, Egress System Manager, enabled the research team to acquire essential information on ejections and related injuries. The timely support provided by Simula Inc., in providing copies of their proprietary Technical Reports (TR-87401, "Development of an Improved Neck for Ejection System Test Manikins"; and TR-88512 "Development of an Improved Neck for Ejection System Test Manikins, SBIR II Final Report"), enhanced the literature review undertaken in this research program.

A special thanks is given to Mr. Roy R. Rasmussen, USAF Project Engineer, as well as Dr. Ints Kaleps and the staff of the Biodynamics and Biocommunications Division, Crew Systems Directorate, Armstrong Laboratory, Human System Division, for their support during this research program.

Finally, the research team gives a very special thank you to the support staff at BRC. Without the super efforts and dedication of Kathy Dickinson in word processing and editing this research program could not have been reported effectively. Appreciation is also due to Frank Christ in project coordination, John Martini and Bob Carlin for illustration support, Tom Kingery in contract management, Lisa Hahn in typing and Janet Trueblood editing.

TABLE OF CONTENTS

Abstract	ii
Acknowledgments	iii
SECTION 1	6
INTRODUCTION	7
Review of ADAM - Purpose and Approach	7
Assessment of Injury Probability	7
The Nature of Injury Criteria	9
Injury Probability Assessment Opportunities	11
References for Section 1	12
SECTION 2	14
PROGRAM OUTLINE AND APPROACH TO LITERATURE REVIEW	15
Outline of Approach	15
Literature and Data Search	15
Scope of Literature Review	15
Specific Topics and Databases Searched	16
Search Strategies Used	19
Additional Search Topics	21
Duplicate References	21
Number of References Retrieved	21
Items Selected for Full-Text Review	21
Document Orders	22
Document Order File	22
Database Creation	22
SECTION 3	24
SELECTION OF CANDIDATE INJURIES FOR ASSESSMENT	25
Operational Escape Injury Experience	25
Serious Injury Occurrence During Various Phases of the Escape	28
Assessment of Additional Relevant Operational Stressors	30
Definition of Selected Injury Mechanisms by Body Region	31
Head	31
Neck	35
Thoracolumbar Spine	37
Chest and Abdomen	38
Upper and Lower Extremities	39
References for Section 3	40
SECTION 4	44
SENSING AND INSTRUMENTATION REQUIREMENTS	45
Assessment of Data Requirements vs. Available Sensor Types	45

Head	45
Cervical Spine	46
Thoracolumbar Spine	47
Thorax and Pelvis	47
Upper Extremities	48
Lower Extremities	49
Assessment of the Need for Joint Torque Instrumentation	50
Instrumentation requirements	54
Linear Accelerometers	54
Angular Acceleration Transducers	54
Potentiometers	55
Load Cells	55
References for Section 4	56
SECTION 5	57
FORMULATION OF INJURY PROBABILITY ASSESSMENT CRITERIA	58
Head	58
Literature Review	58
Proposed Criterion	62
Neck	85
Literature Review	85
Proposed Criterion	93
Thoracolumbar Spine	99
Literature Review	99
Proposed Criterion	103
Chest and Abdomen	106
Upper and Lower Extremities	106
Literature Review	106
References for Section 5	112
SECTION 6	116
OUTLINE OF VALIDATION APPROACH	117
Objectives of the Program	117
Philosophy of Criteria Validation	118
Proposed Validation Program	119
APPENDIX A - Bibliography	122
APPENDIX B - Outline Summary of Analysis of USAF Ejection System Experience since 1975 (Selected Aircraft)	218
APPENDIX C - Data Requirements and Sensors	240
APPENDIX D - Derivation of Six Degree-of-Freedom Equations for the Head	243

SECTION 1

INTRODUCTION

SECTION 1

INTRODUCTION

REVIEW OF ADAM - PURPOSE AND APPROACH

The Advanced Dynamic Anthropomorphic Manikin (ADAM) was developed in response to the Crew Escape Technologies (CREST) program requirements for a human analog demonstrating realistic dynamic response to seat accelerations and windblast forces experienced in an advanced ejection system.^{1,2,3,4} The fundamental advances incorporated into the ADAM design include realistic articulation of a number of joints as well as dynamic axial and flexion response for the thoracolumbar spine. These changes allow the new manikin to respond dynamically to the total force environment experienced by the ejected seat/man combination. This response is of particular interest in ejection systems since the occupant represents a significant fraction of the total ejected weight, implying that motions of the occupant center of gravity (CG) and alterations in aerodynamic characteristics can have substantial effects on the trajectory and performance of the overall system. The opportunity exists to use data from the ADAM, in conjunction with possible additional data from added instrumentation, to simultaneously assess the likelihood of injury for the occupant of such an ejection system. The opportunity was used under this contract to define a general approach for human impact injury criteria. To place in context the potential for using ADAM for injury probability assessment, it is necessary first to briefly review some aspects of injury probability assessment and the nature of injury criteria.

ASSESSMENT OF INJURY PROBABILITY

The potential for injury as a result of whole body acceleration or force application was initially assessed by early researchers using data from human volunteer exposures or reconstruction of human accidents. An extensive body of data currently exists, including many series of tests in which restrained human volunteers are exposed to whole body impacts from various directions. While these exposures commonly define a tolerable range of conditions, misadventures in these programs have occasionally provided data on injury-producing circumstances.⁵ Human cadavers and animal test subjects have been used more commonly as subjects for tests in intentionally injury-producing regimes. Tissue specimens from human cadavers or from animals have also been used to define strength and yield points for individual structures.

From the various available test data, mathematical models have been constructed of the dynamic response of human beings to impact and force environments. Sometimes these models have been simple empirical models or lumped parameter models using a restricted number of mechanical linkages with masses, spring constants, and damping characteristics adjusted to allow the model to respond in a way that approximately mimics human or cadaver response to defined impacts. Other models have attempted to more faithfully duplicate human bony articulations, necessitating large multibody models with many degrees of freedom. The physical constants for such models have been based to some degree on experimental tissue properties, but the overall model parameters are typically adjusted to allow the response of the model system to be comparable

to human or cadaver response to defined impacts. Unfortunately, the many degrees of freedom of such models typically have not allowed validation of the model's assessment of load and injury likelihood at individual points within the model structure. Finite element modelling has been employed to estimate internal stresses and strains for body tissue such as the skull and brain.

Mathematical models may be descriptive or predictive. Descriptive models may assist in understanding the observed behavior of a system. Predictive models describe the behavior of a system in regimes that have not been observed. This is relatively easy when the regime lies between two regions in which the behavior has been observed. Conversely, it is relatively difficult to extrapolate beyond observed regions, particularly when nonlinearities (injuries) come into play.

While mathematical models have been useful for assessing well defined, simple input functions, the complex nature of the physical and aerodynamic force environments in situations of interest have been more difficult to fully describe and evaluate. Therefore, the various mathematical models of human or cadaver response have often been used as bases for the construction of anthropomorphic test devices (ATDs) that can subsequently be exposed to the environment of interest. Unfortunately, the degree to which the ATD responds in a representative fashion to these more complex environments remains as difficult to evaluate and validate as the most complex models. Most troubling has been the use of ATDs in environments not traceable to the design criteria upon which the ATD was based. For example, ATDs designed to mimic cadaver response to forward-facing impact have been used in vertical impact tests with misleading results. It has been irresistibly tempting to use a structure that "looks like a person" against challenges for which it was not designed.

Any use of ADAM-derivative technology for the purpose of injury probability assessment must, therefore, be within the range of challenges for which ADAM may be shown to represent relevant human response. This necessarily imposes limitations on the environments in which injury criteria are applicable, but it must be recognized as the fundamental assumption underlying the development of injury criteria pursued in this report. In effect, the ATD is a possibly imprecise mechanical realization of a mathematical model in the sense that mathematical modelling is employed to aid in setting ATD design parameters. For purposes of this study, the accuracy and representativeness of the ADAM response is not being assessed, but rather being assumed as representative or capable of being made representative.

The use of an instrumented ATD as an injury probability assessment tool goes a step beyond previous approaches which were based upon simple instrumentation of the environment. For example, in an ejection scenario, the simplest instrumentation solution is to measure the acceleration time profile of the seat. This necessarily ignores the differences in acceleration time histories experienced by different portions of the body of a human being seated in such a seat. The availability of an articulated ATD with human-like response to the accelerations and rotations of an ejection seat allows attention to be focused upon various regions of the body with these regions' varying stress environments being represented by different acceleration time

histories. This is a philosophical departure from injury criteria related to measurements of the environment. It may be termed "regionally based" injury probability assessment rather than "whole body" injury probability assessment. However, it puts one in the position of searching for a model of injury probability assessment that is, in effect, based upon the output of an intervening model represented by the ATD.

Output from instrumentation within the ADAM or another ATD may be employed as an indicator of injury potential if it can be reliably assumed that the mathematical model upon which the ATD is based is correct and the mechanical realization of that model is faithful to it. The instrumentation must also effectively measure accelerations, forces, and torques in a manner relevant to the human body response being modeled. Finally, the measurements must be compared to criteria that reasonably represent the injury likelihood in a given region had a human body experienced the manikin environment.

THE NATURE OF INJURY CRITERIA

The way injury criteria are defined has a potentially dramatic impact on the design of systems that must meet those criteria. If injury criteria are too liberal, injuries are more likely to result during use of the designed system. Conversely, if injury criteria are too conservative, the designed system may be too expensive, too complex, too heavy, or too limited in its performance to adequately meet operational requirements. In fact, if escape system performance is inappropriately constrained, fatalities will result from more out-of-envelope ejections. Therefore, it is critical for injury criteria to be appropriately set so that systems based on those criteria will be both capable and reasonably safe.

The definition of an injury criterion begins with the careful definition of the injury to which the criterion will apply. From a practical point of view, injury criteria cannot be reasonably defined for all injuries conceivable in the use of a given system. Instead, those injuries that are most critical and most likely to occur in a given circumstance are defined and injury criteria established. Too many criteria may lead to unavoidable assessments of failure just as too many clinical tests on a normal patient will eventually yield some abnormal results.

It must be recognized that an injury criterion is not an injury tolerance curve. Instead, an injury criterion is defined as a testing limit which typically is set on the basis of its relationship to multiple tolerance curves for multiple injury modes.

Injury criteria have been approached in a variety of ways. For example, injury thresholds have sometimes been established. In some cases, these thresholds have been used in an absolute sense such that an injury is assumed not to occur if a chosen parameter remains below the threshold and assumed to occur if the parameter exceeds the threshold. More realistic approaches involve threshold ranges in which the actual injury threshold for a population of subjects is assumed to fall somewhere within a given range for the parameter. More precisely defined approaches along this line assign cumulative probability functions to a given parameter such that increasing percentages of a population would be expected to be injured as a parameter increases in value.

Such probability functions imply a greater knowledge about the injury event and its cause and are typically more useful from a system design standpoint since the risk of injury may be compared to the potential benefits of improved system performance.

The parameter for which the injury criterion is defined must be relatable to injury production. Attempts have been made to define injury thresholds or probability functions on the basis of acceleration or force. Difficulties have been encountered since acceleration or force time histories are typically complex functions and the significance of a given level of acceleration or force may depend upon how long that level is maintained or how rapidly it is applied. Additionally, difficulties have also been encountered since local acceleration or force in various portions of the human body differ from the acceleration measured on a seat structure and differ further depending upon restraint design and effectiveness. Much of the data on bone and ligament strength remains as quasi-static yield or failure data that simply defines the force required to be slowly built up before a sample gives or breaks. Acceleration criteria that have been most useful have at least involved information on duration. Examples include the early Wayne State tolerance curves. These demonstrate that acceleration tolerance for certain injuries increases as the duration decreases. However, complex pulse shapes are difficult to describe simply by acceleration or force and duration. Such pulses are more conveniently handled by time-weighted acceleration approaches typified by the Gadd Severity Index or the Head Injury Criterion (HIC). These approaches find current application for whole body or regional acceleration tolerance or generalized head injury occurrence, but they have several deficiencies which will be examined later.

For complex acceleration time histories and specific structural injuries, the likelihood of failure may be better defined by the maximum acceleration or displacement of a mass supported by a spring and damper on an accelerating base. The Dynamic Response Index (DRI) is a probability function example of such a criterion and has been useful in assessing the likelihood of spinal fracture in military ejection seats.⁶ The DRI technique has been extended by Brinkley and colleagues for use with whole body injury potential in multi-axis acceleration environments.^{7,8} The approach is more theoretically consistent with the notion of injury as strain beyond the linear range of a viscoelastic structure subjected to time-varying stress. Viscoelastic displacement criteria are reasonable approaches for modelling skeletal injury.

For soft-tissue injury, the viscous criterion has been introduced by Lau and Viano⁹ for predicting injury in the chest and abdomen. This criterion is a probability function based on the product of displacement percentage and displacement velocity for a viscoelastic model. This approach is consistent with the notion that soft tissue injury depends not only on viscoelastic compression, but also on how rapidly the compression occurs. The viscous criterion is being used in automotive applications for frontal and side impact collisions with a modified GM Hyurid III manikin. Further exploration of side impact phenomena has occurred with manikins specifically designed for the purpose, such as SID¹⁰ and EUROSID.¹¹

A summary of the described injury criteria is presented in a matrix in Table 1. The more sophisticated approaches are located generally down and to the right in the matrix.

Table 1 - INJURY CRITERIA CHART				
PARAMETER TYPE	ACCELERATION OR FORCE	TIME-WEIGHTED ACCELERATION OR FORCE	VISCOELASTIC MODEL DISPLACEMENT	VISCOELASTIC MODEL DISPLACEMENT AND VELOCITY
THRESHOLD	Wayne State Tolerance Curves	Some misuses of Gadd Severity Index and Head Injury Criterion		Some misuses of the Viscous Criterion
THRESHOLD RANGE	Most Tissue Strength Data	Gadd Severity Index and Head Injury Criterion	Some Tissue Strength Data at Varying Strain Rates	
PROBABILITY FUNCTION	Some Tissue Strength Data		Dynamic Response Index (Spinal Fracture)	Viscous Criterion for Chest and Abdomen Soft Tissue Injury

INJURY PROBABILITY ASSESSMENT OPPORTUNITIES

For ADAM-derivative injury assessment, it is appropriate that injury criteria be established only for operationally significant injuries. Such injuries are defined as those that are relatively common and relatively severe. Less common injuries should only be considered when they are particularly severe. Neck fracture provides an example of an operationally significant injury category.

There are more potentially relevant injury possibilities in escape or other acceleration stress environments than can reasonably be accommodated in a given instrumented manikin. This study takes the opportunity to survey potential injury criteria development for a variety of body regions. If all injury criteria developments were to be attempted within the ADAM system, substantial increases in instrumentation and data acquisition channels would be required. Such increases may not be justifiable. In fact, near-term practicality may dictate some retreat from current levels of instrumentation in ADAM. Clearly, some prioritization will be required to determine the best use of available data channels and instrumentation. Allocation decisions may also change from program to program depending upon objectives. Therefore, this study takes the approach of outlining injury criteria for a variety of body regions, recognizing that attendant requirements for additional instrumentation are being assumed. However, it should be made clear that this approach does not serve to recommend the incorporation of all possible criteria and all possible instrumentation. Rather, for applications in which injury criteria within the specific region are considered relevant, selection could be made from among the injury criteria being presented as a part of this study.

This study provides a unique opportunity to place the definition of regional injury criteria on a more rational and consistent footing than currently exists in the literature. As it stands, a wide variety of criteria have been advanced, typically having been developed as a result of studies within a particular body region. Little effort has been devoted to employing a common philosophy to develop injury criteria from region to region. At least in a tentative sense, the current study addresses this rather formidable task.

Underlying the philosophy employed in the current study is the observation that the most relevant and useful injury criteria take into account the viscoelastic strain behavior that characterizes typical human body injury response. The potential exists to employ such an approach thoroughly to develop injury criteria in all body regions based upon measures of viscoelastic strain response. This has intuitive appeal since strain beyond some limit is the parameter most closely linked to the nonlinearity represented by injury to a given tissue. Various approaches to injury criteria using acceleration or force have often attempted to deal with this fact by employing some measure of time duration, rate of onset, or other measure that affects the outcome of a force or acceleration applied at some given level. These considerations can be consistently taken into account if a strain criterion can be established in place of an acceleration or force metric.

The application of a thorough, regional, viscoelastic strain approach has been attempted in this study and is recommended for use in the ADAM program. In a larger sense, however, such an approach not only has application for ADAM, but is also foreseen as an important contribution to the field of injury criterion definition in general. The approach should find application in other military testing, systems specifications, computer-based mathematical models, and in regulatory standards and testing for automotive, commercial aviation, and general aviation settings.

REFERENCES FOR SECTION 1:

1. White, Richard P., Jr. ADAM—the Physical Being. Proceedings of the 25th Annual Symposium of the Survival and Flight Environment Association, Las Vegas, NV, November 16-19, 1987. Newhall, CA, SAFE Association, 141-149 (1987).
2. White, R.P. Jr. The Development of a Dynamic Human Analog. Proceedings of the 11th International Technical Conference on Experimental Safety Vehicles, Washington, D.C., May 12-15, 1987. Washington, D.C., U.S. Department of Transportation, National Highway Traffic Safety Administration, 336-46 (1987).
3. Rasmussen, R.R. Jr., Kaleps, I., Armstrong, H.G. Development of an Advanced Dynamic Anthropomorphic Manikin—ADAM for Military Applications. Proceedings of the 11th International Technical Conference On Experimental Safety Vehicles, Washington, D.C., May 12-15, 1987. Washington, D.C., U.S. Department of Transportation, National Highway Traffic Safety Administration, 332-5 (1987).
4. Bartol, A.M., Hazen, V.L., Kowalski, J.F., Murphy, B.P., White, R.P. Jr. Advanced Dynamic Anthropomorphic Manikin (ADAM). Final Design Report. AAMRL-TR-900-23, March 1990.

5. **Hearon, B.F., Brinkley, J.W., Raddin, J.H.Jr., and Fleming, B.W.Jr. Knee Ligament Injury During Lateral Impact. Aviat, Space Environ Med, 56(1), 1-9 (January 1985).**
6. **Brinkley, J.W., Shaffer, J.T. Dynamic Simulation Techniques for the Design of Escape Systems: Current Applications and Future Air Force Requirements. IN: Biodynamic Models and Their Applications. Aerospace Medical Research Laboratory, Wright-Patterson Air Force Base, OH. AMRL-TR-71-29-2, (1971).**
7. **Brinkley, J.W. Acceleration Exposure Limits for Escape System Advanced Development. SAFE J, 15, 10-16 (1985 Summer).**
8. **Brinkley, J.W., Specker, L.J., Mosher, S.E. Development of Acceleration Exposure Limits for Advanced Escape Systems. IN: Implications for Advanced Technologies for Air and Spacecraft Escape. Neuilly-sur-Seine, France, Advisory Group for Aerospace Research and Development, AGARD-CP-472, 1-1-1-14 (1990).**
9. **Lau, I.V., Viano, D.C. The Viscous Criterion—Bases and Applications of an Injury Severity Index for Soft Tissues. Proceedings of the 30th Stapp Car Crash Conference, San Diego, CA, October 27-29, 1986, (Society of Automotive Engineers Proceedings No. P-189). Warrendale, PA, Society of Automotive Engineers, 123-42 (1986).**
10. **Donnelly, B.R.; Morgan, R.M.; Eppinger, R.H. Durability, Repeatability and Reproducibility of the NHTSA Side Impact Dummy. Proceedings of the 27th Stapp Car Crash Conference, San Diego, California, October 11-12, 1983, (Society of Automotive Engineers Proceedings No. P-134). Warrendale, Pennsylvania, Society of Automotive Engineers, 299-310 (1983).**
11. **Glaesser, K.P. Results of Side Impact Tests with the EUROSID. Proceedings of the 31st Stapp Car Crash Conference, New Orleans, November 9-11, 1987, (Society of Automotive Engineers Proceedings No. P-202). Warrendale, Pennsylvania, Society of Automotive Engineers, 117-27 (1987).**

SECTION 2

**PROGRAM OUTLINE
AND
APPROACH TO LITERATURE REVIEW**

SECTION 2

PROGRAM OUTLINE AND APPROACH TO LITERATURE REVIEW

OUTLINE OF APPROACH

The fundamental objective of the current effort has been to establish an appropriate methodology for using ADAM technologies for injury probability assessment. The methodology has been designed to allow a validation effort to include demonstration tests with a prototype manikin in an envisioned Phase II to follow the current effort. The program has been carried out through the pursuit of a sequence of technical objectives. Fundamental to all of the objectives has been an extensive literature review to better define the injuries of interest for ADAM testing and to assess the state of the art for injury probability assessment criteria. This literature review, in and of itself, represents a significant product of the Phase I study. As such, it is separately addressed in this section to assist users of this report in understanding its basis and its content. It is anticipated that the compilation of articles provided in Appendix A will serve as a beneficial reference source for future related endeavors.

Employing the literature and data search, candidate injury types were selected for assessment based upon the operational significance of those injuries. Significance was defined using both the frequency of the injury and the degree of incapacitation or threat that it represents. A separate effort addressed the instrumentation requirements to provide data from the various body regions that would be relevant to injuries that might be considered. Injury probability assessment criteria were then developed for the various injury modes selected as being potentially significant. An attempt was made to apply a regional viscoelastic strain approach wherever possible. Finally, a validation approach outline has been considered as the basis for the development of a proposal to continue the effort into a second validation phase. Prior to initiation of any Phase II effort, it is recommended that the effort be focused by selecting a subset of the potential injury criteria that would respond to primary Air Force concerns and fit within envisioned instrumentation system sizing. We believe that incorporation of sufficient instrumentation to pursue all considered injury criteria will result in an impractical and unmanageable manikin instrumentation suite.

Before proceeding with the description of the results of the various tasks, the basis and approach for the literature search is briefly reviewed.

LITERATURE AND DATA SEARCH

Scope of Literature Review

The literature search undertaken in this effort was organized as a series of thorough scans of the English-language literature on specific topics. The review was not intended to be entirely

exhaustive nor irrefutably comprehensive. Most of the databases ultimately selected for searching are themselves limited in scope, e.g., by time period, types of publications included, countries of publications covered, and so on. The actual search strategies, i.e., the specific words and phrases and the ways in which they were combined, further determined the results found and the references ultimately printed. However, the specific databases selected for searching, the search strategies employed, and the full-text documents subjectively selected for review from the literature search bibliographies, have resulted in a list of references that provides a reasonable sampling of the relevant literature that could be obtained in time to be thoughtfully reviewed within the contract period. There was no attempt to construct a comprehensive historical review. Therefore, many significant contributors and contributions to the field are missing from the selected bibliography. However, a reasonable sample of useful concepts and approaches was assembled to serve as a basis for the current effort.

Of interest in the review was our observation that there is too much literature in this field. We have been blessed with the curse of relatively unconstrained access to publication. This ensures that revolutionary ideas get a hearing, but also allows publication of less insightful or flawed studies having results that cannot be rationalized from study to study.

Specific Topics and Databases Searched

Two distinct primary topics were identified as crucial in defining the relevant literature: Injury Assessment (limited to specific anatomical regions) and Escape Injuries.

The Principal Investigator and Librarian selected databases in which to search these topics from those offered by the on-line bibliographic systems already subscribed to by Biodynamic Research Corporation. These systems, accessed by modem, include Dialog Information Services, Inc., the Defense RDT & E On-line System, MEDLARS, and Maxwell On-line, Inc./Orbit Search Service. Descriptions of these systems follow.

DIALOG Information Services, Inc. provides access to databases from a broad scope of disciplines including science, business, technology, chemistry, law, medicine, engineering, social sciences, business, economics, current events, and more. The more than 380 databases on DIALOG contain in excess of 260 million records.

DROLS, which stands for the Defense RDT & E On-line system, was developed by the Defense Technical Information Center to provide on-line access to its collection. DROLS provides access to three databases: Research and Technology Work Unit Information System (WUIS) Database, the Technical Report (TR) Database, and the Independent Research and Development (IR & D) Database.

MEDLARS is the National Library of Medicine's on-line retrieval system that provides access to about 25 health-related databases including Medline, Bioethics, Cancerlit, Health Planning & Administration, and Toxline.

ORBIT Search Service, a division of Maxwell Online, provides access to more than 100 computerized databases heavily concentrated in the areas of science, technology, and patents including Biotechnology Abstracts, Chemical Safety NewsBase, Enviroline, Society of Automotive Engineers (SAE), Global Mobility, and U.S. Patents.

Eight individual databases were chosen to search both the Injury Assessment and Escape Injuries topics. These databases were selected by the Principal Investigator and Librarian as a result of their past research and literature searching experiences. The following paragraphs describe these databases, provided in the DIALOG and MAXWELL ONLINE services' 1991 database catalogs and other documentation provided by the services.

The Aerospace Database provides references, abstracts, and controlled vocabulary indexing of key scientific and technical documents as well as books, reports, and conferences. Aerospace research and development in over 40 countries, including Japan, Eastern Europe, and the countries of the former Soviet Union are covered. This database supports basic and applied research in aeronautics, astronautics, and space sciences, as well as technology development and applications in complementary and supporting fields such as chemistry, geosciences, physics, communications, and electronics. It is provided by the American Institute of Aeronautics and Astronautics/Technical Information Service (AIAA/TIS). The Aerospace Database combines in one database two publications: Scientific and Technical Aerospace Reports (STAR), produced by the National Aeronautics and Space Administration (NASA), and International Aerospace Abstracts (IAA), produced by AIAA under contract to NASA.

The Compendex Plus database, provided by (Ei) Engineering Information, Inc., is the machine-readable version of the Engineering Index (monthly/annual), which provides abstracted information from the world's significant literature of engineering and technology. The Compendex Plus database provides worldwide coverage of approximately 4,500 journals and selected government reports and books. Subjects covered include: civil, energy, environmental, geological, and biological engineering; electrical, electronics, and control engineering; chemical, mining, metals and fuel engineering; mechanical, automotive, nuclear, and aerospace engineering; and computers, robotics, and industrial robots. In addition to journal literature, Compendex Plus includes over 480,000 records of significant published proceedings of engineering and technical conferences formerly indexed in Ei Engineering Meetings.

The Defense Technical Information Center's Defense RDT & E Online System (DROLS) has two databases to which BRC has access. They are the R & T Work Unit Information System (WUIS) Database, which is a collection of technically-oriented summaries describing ongoing Department of Defense research and technology effort at the work unit level. This database includes information concerning the what, where, when, how, and what costs, by whom, and under what sponsorship research is being performed. The collection consists of approximately 206,000 records. The Technical Report (TR) Database is a collection of bibliographic citations to documents that convey progress or results of Defense-sponsored RDT & E efforts. The collection consists of over 1.7 million documents stored in microform, of which over 1.4 million are under computer control.

Medline (MEDLARS onLINE), produced by the U.S. National Library of Medicine, is one of the major sources for biomedical literature. **Medline** corresponds to three print indexes: **Index Medicus**, **Index to Dental Literature**, and **International Nursing Index**. **Medline** covers virtually every subject in the broad field of biomedicine, indexing articles from over 3,000 international journals published in the United States and 70 other countries. Citations to chapters or articles from selected monographs are also included from May 1976 through 1981. Over 40% of records added since 1975 contain author abstracts taken directly from the published articles. Over 250,000 records are added per year, of which over 70% are for English-language material.

The **NTIS** database, provided by the National Technical Information Service, consists of government-sponsored research, development, and engineering, plus analyses prepared by federal agencies, their contractors, or grantees. It is the means through which unclassified, publicly-available, unlimited distribution reports are made for sale by agencies such as NASA, Defense Documentation Center (DDC), Department of Energy (DOE), Housing and Urban Development (HUD), Department of Transportation (DOT), and Department of Commerce (DOC). Some 240 other agencies now contribute their reports to the database. Truly multi-disciplinary, this database covers a wide spectrum of subjects, including administration and management, agriculture and food, behavior and society, building, business and economics, chemistry, civil engineering, energy, health planning, library and information science, transportation, and much more.

The **SAE Global Mobility Database** provides access to technical papers presented at Society of Automotive Engineers (SAE) meetings and conferences, papers from the Société des Ingénieurs de l'Automobile (SIA) and the International Federation of Automobile Engineering Societies (FISITA), transportation-related papers from the Institution of Mechanical Engineers (I Mech E) and the National Highway Traffic Safety Administration (NHTSA)-sponsored International Technical Conference on Experimental Safety Vehicles (ESV). Also, the databases cover standards, specifications, test procedures, recommended practices and proposed standards developed by SAE, as well as SAE Special Publications, Advances in Engineering series books, and authored books. Subject coverage includes automobiles, aircraft and other self-propelled vehicles such as spacecraft, military equipment/vehicles, trucks, tractors, motorcycles and agricultural vehicles. Topics include safety, design, materials, manufacturing, testing, marketing, and fuels. The database currently contains more than 49,000 records.

TRIS (Transportation Research Information Service) is provided by the U.S. Department of Transportation and Transportation Research Board NAS/NRC. **TRIS** supplies transportation research information on air, highway, rail, and maritime transport, mass transit, and other transportation modes. Subjects included are regulations and legislation, energy, environmental and maintenance technology, and operations, traffic control, and communications.

The database records can either be abstracts of documents and data holdings or résumés of research projects. Among the transportation research information services contributing to **TRIS** are the Highway Research Information Service (HRIS), the Maritime Research Information Service (MRIS), the Railroad Information Service (RRIS), the Air Transportation Research

Information Service (ATRIS), the Urban Mass Transportation Research Information Service (UMTRIS), the International Road Research Documentation (IRRD), Transportation Libraries (TLIB), and Highway Safety Literature (HSL).

Biodynamics Data Bank. The Armstrong Laboratory, Human Systems Division, Air Force Systems Command, Wright-Patterson Air Force Base, OH, generously supplied BRC a copy of its entire Biodynamics Data Bank. This database was found to contain references, often with abstracts, to publications or materials outside the scope of the other commercial and DTIC databases searched.

Search Strategies Used

Search Logic

Within a search strategy, descriptors, free-text words and/or phrases, and groups of these, can be combined in various ways to get different results. These connectors, called Boolean logical operators or proximity operators, can either broaden or narrow the number of items found as a result of a search strategy. A brief summary of the available operators follows.

OR logic groups search terms inclusively into a single set when any of the given terms is acceptable. For example, in the Medline database where no descriptors existed for the Escape Injuries concept, synonyms or closely-related terms or phrases such as "injuries", "trauma", "fractures", and "dislocations", and variations of these, were used to search on the "injuries" portion of this concept; additional synonyms such as "escape", "ejection", and so on were also selected to complete the expression of this concept.

AND logic retrieves the intersection of at least two search terms. All records must contain both or all of the terms specified. For example, the free-text terms used to express the "injuries" concept listed above, were **AND**-ed with a group of synonyms selected for expressing the "escape" concept. This strategy retrieved only those items containing at least one term from each of the two groups of synonyms.

NOT logic eliminates unacceptable or irrelevant terms from a search. **NOT** was often used within literature searches to avoid looking again at references found in previous search sets.

Other proximity operators are available on the DIALOG, MAXWELL ONLINE, and MEDLARS online systems that produce even more precise results than when the Boolean operators, **AND**, **OR**, or **NOT** are used. These require that the terms or phrases in both concept groups appear in closer proximity to each other, e.g., in the same sentence, in the same field of the bibliographic record, in the same descriptor, and so on.

Subject terms and headings

Most bibliographic databases available through commercial suppliers use a controlled vocabulary of standardized words and phrases called descriptors to index the subject contents of their publications. In order to maximize the retrieval of relevant results on a subject, a literature searcher uses these descriptors within a search strategy rather than a variety of free-text words and phrases. Thesauri for the individual databases selected for searching were consulted to identify the descriptors available for searching the two major topics selected for this literature search, i.e., Injury Assessment (of selected anatomical regions) and Escape Injuries.

No precise descriptor(s) was available for the Escape Injuries concept in the controlled vocabularies developed for use with the COMPENDEX PLUS, MEDLINE, SAE GLOBAL MOBILITY and TRIS databases. Consequently, the searcher developed a variety of strategies to scan the literature using combinations of synonyms or closely-related terms or phrases to express both the "escape" concept (such as "escape", "ejection" and "parachuting") and the "injuries" (such as "injuries", "trauma", "dislocations", and "fractures") concept.

The remaining databases, Aerospace, NTIS, Technical Report and the Work Unit files all had standardized descriptors available for directly searching the escape injury literature.

The Injury Assessment component of the literature search was more challenging. Medline was the only database with a standardized descriptor approximating the concept of injury assessment, "Trauma Severity Indices". Not surprisingly, Medline also had the best array of single words or phrases for all of the anatomical regions selected for this search, namely, "head", "cervical spine/neck", "thorax", "spine" and "extremities". For the remaining databases, groups of synonyms for all three concepts of "injury" and "assessment" and "head" or "cervical spine/neck" or "thorax" or "spine" or "extremities" were selected.

The DIALOG system was used to search the Aerospace, Compendex Plus, Medline, NTIS, and TRIS databases. Initial searches on the databases were composed using the broadest logical operator, the AND. However, these strategies resulted in thousands of references being identified, particularly in MEDLINE, the large, health-related database.

After scanning some representative titles from the initial results, the searcher decided to use a more focused strategy to accomplish two objectives: reducing the number of references retrieved and increasing the relevancy of the resulting references. The literature searcher decided to use the NEAR operator that specifies that two terms must occur next to each other but in any order. This operator was used to combine synonymous terms and phrases for the "injury" and "assessment" and all of the anatomical regions concepts. At least one word or term in each group had to occur within 5 words of the next group of words or phrases outlined in the search strategy. This narrowing approach yielded a more manageable number of relevant "hits" that appeared to be more on target than those hits found using the more general Boolean operator AND. The equivalent proximity operator was used for searching the SAE GLOBAL MOBILITY file on Maxwell Online.

DTIC's Technical Report and Work Unit databases had to be searched differently and using a broader approach as no proximity operators are available on this system. The AND operator was used but the "injury", "assessment" and anatomical region synonyms were limited to occurrence in the titles of technical reports or research summaries.

The search strategies used with the Biodynamics Data Bank were also generally broader in scope than those used with DIALOG, MAXWELL ONLINE, or the MEDLARS systems.

Additional Search Topics

Literature searches were also run on the same group of commercial on-line databases for information on "instrumentation of anthropomorphic test dummies" as well as for general information on selected anthropomorphic test dummies such as ADAM, BIOSID, EUROSID and the HYBRID III.

Appropriate controlled vocabulary rather than a free-text approach was used to develop search strategies whenever possible in an attempt to control the amount and value of the information found.

Duplicate References

Different selected databases sometimes scan the same publications. Duplicate references were weeded by the individual reviewers as they scanned the search printouts from different databases or before orders were placed for hard copy. Many individual papers and publications were selected by more than one reviewer.

Number of References Retrieved

For all systems and databases searched, the total number of references scanned initially by all reviewers was 9,035. This number did include many duplicate references cited across different databases and on-line systems. From this total of 9,035, the reviewers selected abstracts if they were not already included in the initial searches. Some initial search printouts did include abstracts if time and cost savings were considered significant factors. Overall, 1,936 documents were then selected for full-text review, or 21.4% of the total number of references found across all databases for all topics searched. Duplicate selections were screened before orders were placed. Approximately 975 unique documents were then distributed to the literature reviewers or 49.6% of the documents selected. Table 2 provides details on the literature results, selections and documents ordered.

Items Selected for Full-Text Review

The Principal Investigator assigned specific topical areas to different reviewers. The reviewers first scanned the literature search printouts for their topics that contained basic bibliographic references. They then selected those references for which they wanted to see an abstract or

summary when one was available from the on-line database. Sometimes abstracts were included in the initial printouts to save time and reduce steps in the review process. After examining the abstracts, the reviewer then further narrowed the scope of the literature survey by choosing those papers and publications that he wanted to access in their entirety.

Approximately 600 documents were ordered from commercial document suppliers or the Defense Technical Information Center (DTIC) or were obtained from Wright-Patterson or copied at libraries in the San Antonio area.

Additional materials were also sometimes obtained as a result of a reviewer's scan of a requested paper's bibliography. These sources are not counted in the figures provided in Table 2. They are, however, included in the comprehensive bibliography included in this report in Appendix A.

Document Orders

The Librarian first consulted the BRC Library collection as well as personal office libraries at BRC to see if materials were available on-site. If not, orders were "batched" and submitted to several suppliers with which BRC already had contractual arrangements. Some materials were obtained from other libraries in the San Antonio area. This document ordering and delivery process continued throughout the contract period.

Document Order File

Copies were made of any citations selected from the literature search printouts for inclusion in a document order card file. In this way, duplicate orders were eliminated, invoices from various document suppliers could be more easily checked against documents actually received, and database records could be created in advance of receiving an order.

Database Creation

A database was created of all items requested using the PRO-CITE program developed by Personal Bibliographic Software, Inc. of Ann Arbor, MI. For each item selected and reviewed, a record was entered that contained fields of information including the authors (or editors), document title, source publication, date of publication, number of pages and frequently an abstract (usually written by the author and available from the source document or database record provided through the on-line service). The reviewers assigned a value to the publication ranging from "Limited Utility" to "Useful Source" to "Primary Source". The resulting full bibliography of items is included in this report in Appendix A. Bibliographies of selected source documents reviewed for particular topics and rated either as a "Primary Source" or a "Useful Source" are printed in bold type.

TABLE 2

TOPIC SEARCHED	REFERENCES FOUND	DOCUMENTS SELECTED
<u>INJURY ASSESSMENT</u>		
ALL BODY REGIONS		
Technical Report Database	158	12
Work Unit Information System ¹	108	17
Federal Research in Progress Database ¹	255	5
Commercial Database Updates/Expanded Searches	468	16
TOTALS	989	50
HEAD INJURIES		
Commercial Databases	2613	504
Biodynamics Data Bank	136	21
TOTALS	2749	525
NECK/CERVICAL SPINE INJURIES		
Commercial Databases	268	122
Biodynamics Data Bank	60	0
TOTALS	328	122
EXTREMITY (UPPER & LOWER) INJURIES		
Commercial Databases	1751	270
Biodynamics Data Bank	194	92
TOTALS	1945	362
THORAX/THORACOLUMBAR SPINE INJURIES		
Commercial Databases	651	323
Biodynamics Data Bank	217	144
TOTAL	868	467
<u>ESCAPE INJURIES</u>		
Commercial Database	822	204
DTIC (Technical Report & WUIS Databases)	242	53
Biodynamics Data Bank	168	56
TOTALS	1232	313
<u>ANTHROPOMETRIC TEST DUMMY INSTRUMENTATION</u>		
Commercial Databases	456	40
Biodynamics Data Bank	48	9
TOTALS	504	49
<u>ANTHROPOMETRIC TEST DUMMIES (GENERAL)</u>		
Commercial Databases	420	48
TOTALS	420	48
<u>GRAND TOTAL²</u>	<u>9035</u>	<u>1936</u>
<u>GRAND TOTAL OF DOCUMENTS REVIEWED³</u>		<u>972</u>

¹ Non-bibliographic database. Provides summaries of ongoing research activities not references to source documents.

² Includes duplicate references across on-line systems databases and different reviewers' subject categories.

³ Excludes papers reviewed for more than one topical category.

SECTION 3

SELECTION OF CANDIDATE INJURIES FOR ASSESSMENT

SECTION 3

SELECTION OF CANDIDATE INJURIES FOR ASSESSMENT

OPERATIONAL ESCAPE INJURY EXPERIENCE

Given the development objectives of the ADAM manikin to faithfully respond in a human-like fashion to the accelerations and rotations of an ejection seat, the principal application for ADAM injury probability assessment must begin with attention to the ejection or escape environment. To develop a realistic list of injury candidates for assessment, an analysis of actual injuries occurring in real-world escape mishaps was required. It was considered desirable that this analysis include type, frequency, and severity of injury, as well as the mechanism involved in its occurrence. It was also considered important to estimate how the historical occurrence experience might be altered in anticipated future escape conditions.

While a number of useful compilations exist, it was seen early on that no single compilation met all of the desired requirements. Most published studies were too narrowly focused on specific injury types or upon injuries occurring in a specific phase of the ejection sequence. In the more broadly focused compilations in the literature, it was difficult to assess with confidence the mechanisms of injury production, particularly for the extremities and the neck, or the specific phase of the ejection sequence in which the injury was incurred.

Data was also reviewed for other injury-producing environments. Injury caused by human exposure to trauma has been studied from a variety of perspectives. There is a growing body of knowledge related to mechanisms of injury and injury types associated with certain sports activities. Mechanisms of cervical spine and knee injuries have received particular attention in contact sports settings such as football. However, more complex injury producing events such as motor vehicle accidents involve a broader range of injury producing mechanisms. Consequently, studies having a broad focus in these areas typically lump various injury types together by body region. Studies have frequently attempted to allow comparisons of outcome severity depending upon variations in protective equipment. From an epidemiological perspective it has often been necessary to employ measures of the significance of particular types of injury to an occupant. These measures are necessary to assess the benefit of a protective approach that trades off injuries of one kind for injuries of another. A successful measure of injury significance has been the Abbreviated Injury Scale (AIS) developed under the sponsorship of the Association for the Advancement of Automotive Medicine. This scale, in conjunction with an extended injury severity scale, has allowed comparisons among populations of injured motor vehicle occupants.^{12,13} However, the aggregation of different injury types by these techniques obscures the definition of individual injury mechanisms.

For comparison of escape injury data, compilations have typically been maintained by flying service organizations around the world. Most commonly, instead of a system such as the AIS, overall injury categories are defined in which a crewmember's injuries may be classified in a

four or five level scale ranging from None to Fatal. Such categorization schemes may include injuries termed as None or Minimal, progressing to Minor, then Major, and finally Fatal. Criteria for categorizing an individual crewmember's injuries often differ from service to service. Furthermore, criteria for inclusion in the overall category of ejection injury also vary from service to service. For example, the US Air Force defines an ejection-related injury as one occurring in a crewmember whose escape system has been actuated. Much of the data in the US Navy, by contrast, relates only to crewmembers whose systems have been actuated and in which the ejection has proceeded to the point of separation from the aircraft.

A variety of publications have compared the outcome by injury category in various ejection regimes, ejection systems, or with differences in protective techniques. A particularly detailed accounting was published in the early 1980s by Guill and co-workers, who presented data from the US Navy experience.^{14,15,16,17,18}

Within the US Air Force, various authors have reviewed overall escape experience or experience with specific kinds of injuries, specific escape systems, or specific aircraft. Moseley reviewed 2,000 cases of aircraft accident injuries related principally to crash events through the mid-1950s.¹⁹ Escape systems came into use in the 1940s and by the 1950s some grouped assessments of escape injury experience were being reported. Many of these reports related only to peacetime ejection with data on wartime ejections being less accessible. However, Lewis eventually reported anecdotal data on ejection injuries described by returning prisoners of war following the Vietnam Conflict.²⁰ Recent reports of ejection injuries include those by Shannon from 1969 to 1972, Harrison from 1971 to 1977, and annual reports of USAF ejection statistics published by the Air Force Inspection and Safety Center and typically presented at the Survival and Flight Equipment Association (SAFE) meeting. The results demonstrate a period of perceived decline in survivability that was related, in large part, to increased numbers of usually low altitude out-of-the-envelope ejections with survival precluded as a result of premature ground contact before parachute deployment.

With regard to specific injuries, many authors have published on vertebral fracture experience with the results indicating a bi-modal distribution along the thoracolumbar spine. The mid-thorax (T5-T8) and the thoracolumbar junction (T11-L2) were the regions most often injured with some aircraft or escape systems tending to involve one of these regions more than the other. Many reports have demonstrated increased numbers of fractures at the thoracolumbar junction. Reports by Hearon²¹, et al demonstrated increased incidence of fractures in the mid-thoracic region for the F-111 escape module.

Limb flail injuries have been reviewed by Combs for 1967 to 1977,^{22,23} by Belk for 1971 to 1978,²⁴ and by Delgado for 1979 to 1985.²⁵ Combs found more upper extremity injuries than lower extremity injuries with the injuries including fractures of long bones and derangement of proximal joints. He believed the principal mechanism was hyperextension of the elbow, hyperabduction of the shoulder, and external rotation for the leg. Combs' review was confined to the F-4 aircraft and noted 76 severe injuries in 43 ejectees out of an overall ejection population of 399. Belk's review included 447 open-seat ejections with 33 individuals incurring

significant injuries ascribed to wind flail. Thirteen of these injured crewmembers were also in the F-4 population and overlapped the population reviewed by Combs. The injuries reported by Belk were more evenly distributed between upper and lower extremity. This is noteworthy since the F-4 includes an active leg restraint mechanism, while some of the other aircraft included in the population reviewed by Belk were not so equipped. Again, Belk's data related largely to fractures of long bones with dislocations or derangements of major joints, typically the shoulder, elbow or, less commonly, the knee. Delgado found that the mean ejection air speed decreased during the first half of the 1980s with a corresponding decline in limb flail injury incidents. Delgado's data does not overlap with that of Belk. He analyzed 453 ejections involving open-seat systems in which the airspeed and injury cause was reasonably well known and in which fatal injuries were less than extreme. Of 293 ejections, 15 limb flail injuries were noted, all occurring at speeds in excess of 300 knots. Of those injuries occurring in the F-4, all were of the upper extremity. Once again, the injuries reviewed by Delgado appeared to largely involve long bones or proximal joints.

A particularly intriguing article by Shannon in 1971 reported ejection experience in the SR-71.²⁶ Only six SR-71 ejections were approved for public release. Four of these involved ejections in the supersonic regime with one at 9,000 feet at Mach 1.2, another at 30,000 feet at Mach 1.4, and two at 78,000 feet at a speed in excess of Mach 3.0. Two thoracic compression fractures were noted. There was one fatality among these four, which, according to Shannon, was unrelated to the function of the escape system or, apparently, the dynamic environment imposed during the escape.

Reports of ejection injury experience have proven difficult to interpret in part because of the wide variety of systems employed and the difficulty in assigning specific mechanisms. Furthermore, accident board reports list injuries at various levels of detail from accident to accident. Some fatalities, for example, are coded as "multiple, extreme" in circumstances of premature ground contact prior to parachute deployment. Other boards may detail the injuries by body region even when high speed ground contact occurs. Therefore, it is difficult to assess the significance of individual entries in some injury lists, particularly when fatalities are included. It is extraordinarily difficult to select, from among the fatalities, those which had a single "but for this" type of injury which represents a practically preventable fatality. Other difficulties in this data include the experience with older systems which employed different parachute opening and seat-man separation techniques that exposed crewmembers to increased risk of injury due to poor alignment at parachute opening and due to potential seat strikes following parachute opening.

Nevertheless, it is clear that injuries of significance to ejecting crewmen include injuries to the head, neck, thoracolumbar spine, and extremities. Injuries to the chest and abdomen, while occasionally being observed in survivors, appear relatively rare by comparison to the other groups.

SERIOUS INJURY OCCURRENCE DURING VARIOUS PHASES OF THE ESCAPE

As a foundation for the current study, it was considered necessary to attempt to update the experience with ejection injury with a view toward defining injuries of current potential significance and assessing trends for the future. Therefore, a review was instituted using data from a variety of US Air Force aircraft since 1975. The material for this review was made available by the Air Force Inspection and Safety Center and included 620 escaping crewmembers in six basic categories of aircraft as presented in Table 3. Over half of the ejections were from variants of the F-4 using Martin Baker escape systems with lower extremity restraints. Eighty-three of the crewmembers used an ejection module, the vast majority in variants of the F-111. The remainder of the ejections were in various versions of the ACES II seat in the A-10, B-1B, F-15, and F-16. Eleven of the ejections in these aircraft, however, used an earlier version seat known as the Escapac installed in early production runs of the A-10 and F-15.

TABLE 3 - 620 USAF ESCAPE SYSTEM USERS		
AIRCRAFT CATEGORY	ESCAPES	TIME PERIOD
A-10 (3 with Escapac)	34	From 1975 to 1991
B-1A and B-1B	15	From 1975 to 1991
F-4C, D, DC, E, G, RF-4C, and E	328	From 1976 to 1991
F-15 including B, C, and D (8 with Escapac)	47	From 1975 to 1991
F-16 including B, C, and D	116	From 1975 to 1991
F-111A, D, E, and F	80	From 1976 to 1991

Of the 620 crewmembers escaping, 394 sustained less than serious injury, representing 64%. There were 126 fatalities (20%) and 100 major injuries (16%). A total of 1,873 injuries were reported ranging in significance from minor to fatal. These injuries were reviewed by an experienced flight surgeon who made approximate estimates of minimum injury severity on a scale as shown in Appendix B and additionally scaled for an estimate of potential minimum operational impairment represented by the injury. Injuries were also assigned to one of eight phases in the escape sequence beginning with initiation and ending with ground encounter. An injury significance rating was compiled as a product of the injury severity and operational impairment ratings. This significance rating was subjectively modified by an override rating to ensure that the significance of injuries to the neck, back and extremities were highlighted for potential aeromedical significance. Injuries of unlikely clinical or operational significance were discarded, resulting in the elimination of 822 injuries from the original 1,873. The resulting tabulation was grouped by common injury location and overall crewmember injury severity category and is presented in Appendix B. A presumptive assignment of ranges of Abbreviated Injury Scale (AIS) ratings was also accomplished to compare with the more subjectively assigned clinical and operational significance assessments. A summary of the tabulation is shown here in Table 4.

TABLE 4 - 620 A-10, B-1, F-4, F-15, F-16 AND F-111 ESCAPE SYSTEM USERS SINCE 1975						
REGION		SIGNIFICANT INJURIES (INCLUDING 126 FATALITIES - 126 FATALITIES = EXCLUDING 126 FATALITIES)				
Head:	Skull Fracture Brain Injury Concussion	87	—	74	=	13
Neck:	Fracture Sprain/Strain	38 65	—	30	=	8 65
Thoracic Spine:	Fracture Sprain/Strain	127 9	—	26	=	101 9
Lumbar Spine:	Fracture Sprain/Strain	41 8	—	13	=	28 8
Back Strain/Sprain		56				56
Rib Fracture		44	—	40	=	4
Shoulder:	Fracture Sprain/Strain	16 10	—	7	=	9 10
Upper Arm:	Fracture	27	—	18	=	9
Lower Arm:	Fracture	27	—	20	=	7
Pelvis:	Fracture	15	—	13	=	2
Upper Leg:	Fracture	19	—	15	=	4
Knee:	Sprain/Strain	15				15
Lower Leg:	Fracture	31	—	26	=	5
Ankle:	Fracture Sprain/Strain	7 10	—	3	=	4 10
Extremity Amputation		36	—	36	=	0

Several observations are necessary in interpreting the data. The tabulations are presented with and without inclusion of the injuries listed for the 126 fatalities in the population. A number of the fatalities received multiple, extreme injuries that were often tabulated in detail. However, detailed listings of injuries received by crewmembers who impact terrain at high speed are not likely to be instructive in defining potential injury avoidance schemes that presuppose an operating escape system with parachute deployment. On the other hand, exclusion of the fatalities in total also excludes those more significant injuries to crewmembers with fatal outcomes in which one or two potentially preventable injuries influence the fatal outcome. Therefore, the tabulations are presented both ways, since it was not entirely feasible to exclude only those fatalities which were clearly unavoidable.

Another observation on the data is that injury patterns are heavily driven by the population of aircraft available for this review. The experience in the F-111, for example, probably drives a part of the preponderance of thoracic spine fractures over lumbar spine fractures in this population. Among surviving crewmembers, 25 fractures or dislocations were noted in the upper extremity (shoulder/upper arm/lower arm). There were 15 fractures of the lower extremity (pelvis/upper leg/lower leg/ankle). The F-4 leg restraint system probably influenced this distribution. Once again, injuries to the extremities tended to involve proximal joints, most notably the shoulder with more minor injuries noted to the knee. Elbow injuries did not appear prominently in the data, nor did injuries to the wrist. Among survivors, injuries to the chest and abdomen were relatively uncommon.

The data presented in Appendix B define the principal basis for directing the injury mechanism assessment for the ADAM report to head injury, neck fracture, thoracolumbar spine fracture, and injuries to the proximal extremities. The approach taken on this basis was to assess head injury in a generic sense and fracture limits with particular attention to compression loading of the spine and bending loading of the proximal long bones. This approach assumes that effective protective mechanisms applied for these structures will be likely to reduce the occurrence of joint injuries and sprain/strain injuries in the process.

It can certainly be argued that other varieties of injuries to the chest, abdomen, and elsewhere can and do occur. However, the data indicate that such injuries are not modal and that the greatest potential benefit to the crewmember would be provided by successfully addressing the listed injuries through improved escape systems and protective techniques.

ASSESSMENT OF ADDITIONAL RELEVANT OPERATIONAL STRESSORS

While it is anticipated that the principal use of the ADAM manikin will be for testing of ejection seats and other escape systems, provisions should also be considered for applications involving other operational stresses. Examples could include tests simulating loads placed upon the occupant of an aircraft experiencing crash loading or assessment of the effects of forces imposed in birdstrike or canopy loss without ejection. Some of these settings may not require the unique articulated joint motions available with ADAM. However, it is conceivable that the instrumented capability that ADAM represents might well be exploited in a variety of related settings.

In any such application, consideration should be given to the problem of validation of ADAM as a response model in the anticipated environments. Even in the open ejection seat application, validation is expected to present a significant problem in areas such as the parachute landing fall. For an alert crewmember, parachute landing fall dynamics are significantly modified by the action of voluntary muscle groups. A parachute landing fall with the current ADAM would necessarily represent a passive surrogate. Even when considering the parachute landing fall of an unconscious crewmember, no dynamic data has been found against which ADAM performance might be validated as comparable to ground impact behavior of an unconscious

human. Application of ADAM to these conditions involves the hazards always attendant to the use of a model in areas for which it has not been validated and is, therefore, not recommended.

For purposes of arriving at other candidate injuries for criteria development, it will be necessary to make certain assumptions about the environments that might be contemplated. Specifically, the injury criteria will not be addressed in this study for penetrating injury hazards or for localized impacts to soft tissue or to an unhelmeted head. Instead, injury criteria are being addressed that relate to the kinds of forces expected in whole body acceleration events where the forces are applied by seat surfaces, restraint systems, aerodynamic forces and similar circumstances. Therefore, injury hazards associated with canopy fragments, penetrating impactors, thermal stresses, or pressure changes will not be addressed. In addition, it is anticipated that injuries of interest for ADAM tests will be those that would occur in otherwise survivable kinds of circumstances. Therefore, high speed impact with terrain prior to parachute deployment would represent a circumstance that would not benefit from careful discrimination of various injury tolerances.

Provision has been addressed, however, for examination of injury produced in vehicular crash loading to address automotive and US Army vehicular applications. Specifically, these injuries involve similar mechanisms related to head, neck, and thoracolumbar spine. However, extremity injury mechanisms, particularly for the femur, more commonly involve axial loading with bending rather than the more typical bending loads around ejection seat surfaces during flail. Therefore, extremity injuries to long bones will be addressed with attention to axial load as well as to bending loads.

DEFINITION OF SELECTED INJURY MECHANISMS BY BODY REGION

It is clear that far more potential injury mechanisms exist, even for the regions identified in the foregoing section, than can be reasonably addressed by meaningful injury criteria using an instrumented ATD. Some subset of injury types must be defined that represents hazards of significance in the operational setting and that is amenable to instrumentation and injury criterion development. Based upon the foregoing examination of escape injury experience, potential injury types and injury mechanisms were examined for the identified anatomical regions and candidate injuries for criterion development were selected. Literature bases and operational data were examined and the injury mechanism(s) selected on a rational basis. The approach used in the selection will be exemplified by the examination of selected injury mechanisms for the head.

Head

An extensive literature exists on head injury, dating back for hundreds of years. Various schemes have been devised to categorize and describe head injury mechanisms that can include injuries to any of the variety of tissue types present within the human head.

One frequently encountered classification basis separates penetrating from non-penetrating injuries. By their nature, penetrating injuries are localized events. They may produce

significant attendant accelerations, but their principal characteristics relate to the localized nature of their effects. This is not a suitable injury for assessment with an instrumented ATD since the location of the penetrating force must either be known in advance or the surface of the head must be instrumented in a fashion to discriminate localized stresses at any point. Furthermore, the escape injury experience would appear to indicate that penetrating injuries of the head are relatively rare in otherwise survivable escape events. Therefore, injury criterion development will be pursued for the head only for those events resulting in non-penetrating head injury.

Other classification schemes have been based upon discriminating head acceleration events produced by neck loads without head impact from events involving proximate impact of the head against an external physical object. Clearly, injury can be produced to the interior of the head through either mechanism.²⁷ However, the fact remains that for the vast majority of operationally relevant head injuries, a head impact occurs. Therefore, the approach for injury criterion development will center upon head injuries produced by some proximate head impact. In this case, however, it is not necessary to eliminate from consideration those sudden head acceleration events in which proximate impact does not occur since some of the injury mechanisms may be similar and the instrumentation developed for proximate impact events will also provide useful data in circumstances of whole body acceleration. The critical distinction is that the proximate impact must be one in which the effects are generalized in nature rather than localized (as in the case with the previously rejected penetrating head trauma). Fortunately, this is not an unreasonable limitation in the operational case since we may assume impact to a helmeted head in the majority of circumstances. Necessarily eliminated from these considerations would be effects of localized impact to the face with damage to facial structures since these injuries are not amenable to the kinds of generalized instrumentation available for ADAM. Some facial impact assessment approaches have been developed,^{28,29,30} but these approaches are not recommended for ADAM based on the operational ejection experience data.

Distinctions have also been made between the kinds of acceleration and motion imposed by a head impact. Specific differences in injury mechanism, resulting injury type, and injury sensitivity have been pointed out by various authors depending upon whether the imposed acceleration is translational or angular.^{31,32} Others have defined three types of acceleration, including translational, angular acceleration along a curved path with some rotation, and pure rotational acceleration involving no translational motion of the center of mass.³³ While these different kinds of acceleration have physical meaning and can be seen in pure forms, real world head impacts rarely, if ever, involve pure translational or pure rotational acceleration in isolation. In general, all head impact events result in some acceleration of the center of mass of the head and some rotation about that center of mass. Exceptions might include specialized forms of crush injury, but any garden-variety head impact will likely result in some acceleration of the center of mass and some rotation. These may occur in various proportions and have different effects, but any meaningful injury criterion development based upon currently available literature must include assessment of both translational acceleration and rotational acceleration in combination.

Other historical mechanisms of categorizing head injury include various categorization schemes based upon the type of injury rather than the type of stress. Attempts have been made to not only organize the various types of injuries, but also to associate them with one or more of the typical stressors that more commonly produce a given type of injury. A typical categorization scheme by injury type might begin with extracranial injury such as hematoma or laceration to the scalp. This type of injury would not be considered amenable to development of injury criteria for ADAM.

At the next level, injury to the cranial vault in the form of skull fracture is also not a likely injury type for criterion definition for the following reasons. Many varieties of skull fracture involve rather localized stresses to the cranial vault. Even when the stresses are less localized, such as impact with a flat plate, the susceptibility to fracture varies significantly depending upon the area of the cranial vault receiving the impacting contact. A more compelling reason for not centering upon skull fracture as a principal injury mechanism for criterion development is the relative lack of association between skull fracture and the significance of the resulting injury to the victim. An exception to this may be noted with epidural hematoma that is often associated with skull fracture, but the general lack of association remains true in that the clinical outcome of a given head injury rarely is determined to a significant degree by whether a skull fracture (non-penetrating) is present or not.

Moving further into the head, the next typical injury receiving attention is the intracranial but extracerebral hematoma. This may include epidural or subdural hematomas and, in a general sense, also include subarachnoid hemorrhage. These are clearly significant injuries to the victim and worthy of attention. The mechanics of this type of injury have also been reviewed.³⁴ However, it remains difficult to consistently and uniquely relate the occurrence of extracerebral hematomas to measurable physical parameters from the inciting impact. Similarly, with intracerebral hematomas, or bleeding into the brain parenchymal tissue, these may occur at the site of impact (coup injury), opposite the site of impact (contrecoup injury), or diffuse or deeply located intracerebral hematomas apparently related to localized concentrations of shear stresses possibly as a result of interacting shock waves or from stress concentration points.

More generalized injuries include cerebral contusions that may be localized or diffuse and diffuse axonal injury related to disruption of nerve cells or cell processes at a variety of scattered locations through large areas of brain tissue.

Clearly, any meaningful injury criterion related to head injury must provide some discrimination between the likelihood or unlikelihood of the intra- and extracerebral hematomas, cerebral contusions, and diffuse axonal injury. The difficulty in defining criteria relates to the sensitivity of these injuries to various combinations of translational and angular acceleration as well as to the differences in threshold levels for these injury types. Therefore, it may appear unlikely to be able to define a single approach to a head injury criterion that would relate to any or all of the significant internal injury mechanisms.

What at first might appear to be a further complication relates to the fact that functional disturbances in brain processes may occur with or without observable anatomic injuries of the types described above. The diagnosis of concussion is the typical description applied to such a functional interruption. Examination of the escape injury experience and common experience would appear to dictate that if an injury criterion was defined for head injury such that functional disruption of brain processes was discriminated, such a discrimination would also define typical tolerable levels with respect to the anatomically defined injury types outlined above. In other words, if a given impact event could be demonstrated to be tolerable with regard to functional disruption such as concussion, it should be operationally less likely to result in significant risk in a helmet-wearing crewmember for the intracranial hematomas, cerebral contusions, or diffuse axonal injury. In fact, skull fracture would probably be less likely as well.

The foregoing rationale may appear to be contradicted by data which show intracranial kinematics without concussion for pure translational impact and concussion without intracranial injury for pure rotational stress. However, in real-world head impacts, both translational and rotational stress are applied simultaneously. Functional disruption is commonplace. Functional disturbance with anatomic disruption is also frequent. Significant anatomic disruption without functional disturbance is less common but may occur with epidural hematoma in particular. The chosen injury criterion needs to discriminate an operationally relevant transition in stress severity and, therefore, should operate on functional disturbance where it occurs first with increasing stress. The criterion should also, however, discriminate the various forms of anatomic disruption where they occur before functional disturbance for certain types of stress. It may be that the demonstrated relationship of concussion to rotational acceleration stress implies that concussion is more related to a brainstem effect than to the cerebral hemispheres. Nevertheless, the chosen criterion should address both regions.

For these reasons and for operational impairment considerations, it was decided to select for injury criterion development those head injuries resulting in cerebral concussion as a result of combined translational and rotational acceleration produced by proximate impact to a helmeted head without significant localized effects. Where overlaps occur in stress sensitivity such that significant risk of intracranial injury without concussion might be present, the proposed criterion should be defined at such a level that intracranial injury would also be discriminated.

In effect, therefore, the injury criterion being proposed might relate to different anatomical injuries depending upon the particular combination of translational and rotational acceleration being imposed or depending upon the frequency characteristics of the impacting pulse. While such an injury criterion may not be as clinically precise as could be desired, it certainly appears to be the most operationally relevant. Such injuries as those defined in the escape injury experience study would be addressed, including concussion and anatomic intracranial injury, provided that the injury mechanism was not highly localized.

Neck

The injury mechanisms for the cervical spine are bending moments (flexion, extension and lateral bending moments), rotational moments, axial loads (compression, tension) and shear loads. Bony injuries of the cervical spine are usually due to a combination of injury mechanisms, one of which is usually axial compression.³⁵ The specific injury mechanism is usually determined by the head-neck-torso orientation at the time that impact loads or inertial loads are transmitted to the neck.

Non-contact soft tissue cervical injuries are the result of rapid bending of the neck. The bending can be a flexion, extension or lateral motion. During rapid bending, tension forces develop in the convex side of the neck and compression forces develop in the concave side. With violent enough motion, muscle, ligament and joint damage can occur. Present theories relate these injuries to the translational and rotational velocity of the head relative to the torso.^{36,37}

The most common type of fracture is the flexion type, which is frequently associated with compressive loads. The combination of flexion bending and compression usually produces a lower cervical spine injury.³⁸ A frequent fracture with this loading is the wedge fracture, a collapse of the anterior part of the vertebral body, that usually occurs in C5-T1. The wedge fracture is often clinically benign when there is no compression of the soft tissue and no displacement of the vertebral column. Compression fractures also include fractures of the vertebral body margins and cleavage fractures of the vertebral body.³⁹

In some flexion injuries there may be fractures of the spinous processes, caused by tension forces transmitted through the interspinous and supraspinous ligaments, and disruption of these ligaments due to high tensile forces. Disruption of the supporting posterior ligaments may lead to an anterior dislocation (or spondylosis) of the cervical spine. Dislocation of the cervical spine can result in unilateral or bilateral locked facets if sufficient energy is available to disrupt the facet joints and/or slide the inferior facet of the superior vertebral body over the top of the superior facet of the inferior vertebral body. Anterior dislocation may be very unstable and can cause severe neurological damage.

Typical hyperextension fractures are compression fractures of the vertebral arch components of one or more vertebrae caused by axial compressive loading when the cervical spine is in extension. During the hyperextension, high tensile loads on the anterior longitudinal ligament can pull a chip of bone off an anterior edge of the vertebra, a fracture that is called a teardrop fracture³⁵ (not to be confused with the anterior wedge fracture that is also sometimes called a teardrop fracture).³⁸ If the forces are sufficient, the anterior longitudinal ligament may tear resulting in a dislocation.³⁹

The hangman's fracture is caused by an extension moment acting on the upper cervical spine that is usually the result of a force acting on the head. The resulting fracture separates the anterior from the posterior elements of C2 and may disrupt the C2-C3 disc.³⁸

In lateral bending, the facets on the concave side undergo compression and those in the convex side undergo tension. Facets on the compression side can fracture and facets on the tension side can undergo a tearing separation.

Excess rotation of the neck generates a moment around the longitudinal axis of the neck that does not commonly produce injury, probably because the neck can rotate approximately 40° before any appreciable moment develops.⁴⁰ It has been noted that, in conjunction with hyperflexion or hyperextension, rotation increases the possibility of dislocation.⁴¹

High levels of axial loading of the cervical spine, usually with the spine in a relatively straight configuration (with the natural lordosis removed) can result in a burst fracture, a comminuted compression fracture of the vertebral body. Bone fragments from the fractured vertebrae may enter the canal and result in neurologic deficit. Axial loading on the neck, probably with the neck straight or in a slight amount of extension,⁴² can produce a Jefferson fracture, a fracture of the arch of C1. The arch of C1 fractures when the downward driven occipital condyles act as a wedge, causing the ring of C1 to spread and burst apart.³⁸

Shear injuries to the neck come in two basic forms. In the first, a direct blow to the head produces high shear levels at the upper neck that fracture the dens (odontoid). These fractures are usually the result of shear and some vertical compression.⁴² Displacement of the dens is possible, and if it impinges on the cord the result can be rapid death. Direct impact of a surface into the neck can create high levels of shear that can result in dislocation or transection of the spinal cord at the impact site.

In the 620 surveyed USAF ejections, 38 neck fractures occurred (6%) and were attributed to the ejection phase, emergence phase, man-seat separation phase, and the parachute-deployment phase. Only eight fractures occurred among survivors (less than 2%). There were 65 injuries categorized as neck strain/sprains. The data indicate that neck injuries attributed to the ejection phase were not typically associated with fatalities, while neck injuries attributed to the other three phases were more often associated with fatalities. Neck fracture is a reasonable candidate for a "but for this" determinant of fatality, with fractures attributed to fatalities in otherwise survivable events.

The ejection phase is typically characterized by axial loading and hyperflexion of the neck. Five of the eight cervical compression fractures among the survivors were attributed to this phase. Only one additional fracture in this phase was associated with a fatality. By definition, compression fractures include wedge fractures (simple compression fracture) and burst fractures (comminuted compression fracture). Since burst fractures often create significant cord damage through the posterior movement of vertebral fragments into the spinal canal, burst fractures are less likely to be represented under the compression fracture heading. Therefore most compression fractures attributed to the ejection phase probably represent anterior wedge fractures.

The emergence phase is characterized by inertial forces produced by the rocket motor thrust and forces generated by windblast. In the emergence phase the neck fracture/dislocations are presumed to be due to the combination of these inertial and windblast forces that act on the head. These fracture dislocations were always associated with fatalities in the surveyed sample. The windblast forces are thought to produce rapid motion of the head relative to the torso, as well as distraction (tension) and bending forces in the neck.

All of the neck injuries attributed to the man-seat separation phase are apparently related to impacts with the seat. This scenario has the crewman leave the seat and then have a section of the seat strike the head or neck, often after the parachute slows the crewman. Most of the presumed man-seat separation neck injuries were associated with fatalities.

All of the presumed parachute deployment injuries, except the single sprain/strain injury, are thought to be due to parachute opening shock, sometimes involving entanglement with the parachute risers. Neck injuries in this phase were associated with fatalities in the surveyed sample.

The most frequent injuries are fractures and strain/sprains. Strains/sprains are not as significant medically or operationally, nor are they as predictable, and no criteria will be proposed. Injury criteria are proposed for the neck fracture based on axial compression or tension with bending, rotation, or shear. Direct contact injuries from seat strikes to the neck are localized stress injuries considered to be beyond the scope of this effort.

Thoracolumbar Spine

The injury mechanisms for thoracolumbar spine are similar to those of the neck, i.e., shear and axial loads as well as bending and rotational moments. Axial tension injury is probably less common. The relative significance of each injury mechanism varies with the involved anatomy. For instance, the thoracic spine, having a pair of ribs associated with each vertebral body level, enjoys a structural stability not found in either the cervical or lumbar spine. Therefore, dividing the thoracolumbar spine into segments appears to be advantageous in separating injury mechanisms or for modeling purposes.^{43,44,45}

Disregarding contact injuries, thoracolumbar soft tissue injuries are created by either rapid rotation, flexion, extension, or lateral bending. Since compression of muscle, ligament, or tendon tends not to be injurious, it is more common that rapidly applied tension to these structures creates sprains, strains, or macroscopic tears. Subsequent hemorrhage or edema may secondarily create injury to spinal cord, nerve roots, or exiting nerves. Loss of integrity of the bony spinal canal, of course, invites direct injury to the spinal cord; however, cord injury is subsequent to the primary skeletal event and therefore plays a lesser role in injury criterion definition.

Fractures encountered in the thoracolumbar spine are predominantly from compressive loading with flexion. The result is either a burst fracture from pure axial loading or an anterior wedge compression fracture from a combination of axial and flexion loading. Fractures from hyperextension are rare. The levels at greatest risk from bottom loading appear to be the T-11 through L-2 segments, the transition zone between the thoracic and lumbar spine.^{46,47} Other levels found to be at risk in certain systems include the mid-thoracic region from about T-5 to T-8. These fractures also tend to be anterior wedge compression fractures and may relate to stress concentration in this region produced by forces applied through the shoulders in conjunction with axial or horizontal inertial loading of a partially flexed spine.²¹ Associated posterior spinous process avulsion fractures as well as disruption of posteriorly located ligaments may be seen with flexion mechanisms, whereas injury to anterior and posterior longitudinal ligaments may be noted with burst fractures. In the lumbar spine, lateral bending mechanisms, in addition to creating wedge compression fractures, may also be responsible for fracturing transverse spinous processes through tension generated in interspinal ligaments or in tendinous attachments from major muscle groups.

Shear loads applied in a localized manner to the thoracolumbar spine may create fracture dislocations at a given vertebral level and, if of sufficient magnitude, may yield paraplegia or paraparesis from associated spinal cord injury.

The ejection experience data indicates 101 thoracic spine fractures and 28 lumbar spine fractures for a total of 139 thoracolumbar spine fractures among 494 survivors. Some survivors had more than one fracture. This represents the most common regional injury encountered among the surviving crewmembers in the survey. In general, the majority of escape-related thoracolumbar spine injuries tend to be of the less clinically significant type, rarely presenting initially with neurologic sequelae. Rather, these injuries are typically modest anterior wedge compression fractures such as typically occur spontaneously with advancing age and accumulated microtrauma. Nevertheless, some fractures can be not only painful, but some also do result in longer term disability. The eventual outcome over the long term has not been well-studied. Therefore, injury mechanisms to be addressed by the thoracolumbar spine will concentrate principally on fracture relating to axial load with various degrees of bending or rotation.

Chest and Abdomen

The chest and abdomen contain vital organs of significance in surviving mechanical trauma. Injuries to the chest can involve damage to the external structure, including the skin, muscles, and rib cage, as well as damage to the protected internal organs which include the heart, great vessels, and lungs. The abdomen does not afford overall protection from a similar bony protective cage. Therefore, injury to the abdomen externally involves basically skin and muscle groups. However, internal injury can occur to the liver or spleen, both of which are protected under the lower border of the thoracic rib cage, as well as less well protected organs such as the stomach and intestines. The duodenum, kidneys, and pancreas typically are afforded intermediate levels of protection based upon their deep locations and protection from posterior structures, including lower ribs, spine, and large muscle groups.

Fortunately, chest and abdominal injuries are relatively rare among crewmembers ejecting from aircraft. Extensive chest and abdominal injury is, of course, often seen in high speed ground contact among fatalities who were not afforded an open parachute. Among survivors, chest injuries in our sample were largely represented by four occurrences of rib fractures among 494 survivors. By contrast, 15 heart lacerations or ruptures were noted among the fatalities. Abdominal injuries also were uncommon among survivors. Historically, chest and abdominal injury has been noted among survivors of certain high speed ejection events, but once again they do not appear to be modal injuries.

The other noteworthy characteristic about injuries to the chest and abdomen is that they tend to be somewhat localized. Therefore, they do not lend themselves as well to the definition of injury criteria using regionally measured accelerations or forces. For these reasons, specific criteria will not be addressed in the current study for chest and abdominal injury. However, some attention will be devoted in the section on injury criteria to some general observations related to injury probability assessment for these regions.

Upper and Lower Extremities

The injury mechanisms for the extremities are rotational moments (torsion) plus shear and bending loads as well as axial compression or tension loads. Axial loading needs to be addressed in particular for the knee-femur-hip complex.^{48,49} Because localized injuries to the very distal aspects of the limbs can be even more varied than the long bone portions, injury mechanisms for the hand/wrist and foot/ankle complexes will be considered beyond the scope of this endeavor. Furthermore, injuries to the distal extremities, other than the ankle, were not typically encountered among the ejection injuries reviewed in this section. Four ankle fractures were observed among 494 survivors. The known relationship of ankle injuries to parachute landing fall tends to make these injuries less amenable to assessment with ADAM for the reasons outlined previously in the discussion of the ADAM manikin as an unvalidated surrogate for human ground landing impact.

Since localized impacts to soft tissue may occur in many unpredictable ways, injuries so produced are not amenable to ATD instrumentation. Therefore, only non-contact soft tissue injuries will be considered. Non-contact soft tissue injuries are chiefly found as tensile injuries when joints are stressed beyond anatomical and physiological limits or are dislocated with or without attendant fractures.²² Although tendons and ligaments are chiefly involved, neurological insults may also occur.

In general, the most common fractures of limbs are due to shear loads or shear in combination with bending. Within the ejection environment, shear loads and/or bending loads resulting in fractures are encountered as flailing limbs contact surrounding structures. Tensile/dislocation mechanisms from windblast effects resulting in fracture/dislocation of proximal (shoulder and hip) joints and distal (elbow and knee) joints also are noted among ejection injuries.

Axial loading via the knee-femur-hip produces characteristic acetabular fractures. These are not prominent among ejection injuries, but do feature in terrestrial vehicular frontal collisions.⁴⁸ In a kinetics sense, the pelvis is thereby an extension of the lower extremity; although separate and additional injury mechanisms for the pelvis exist through caudal-cranial loading at the ischial tuberosities, antero-posterior loading at the pubic symphysis or lateral loading at the iliac wings. Pelvic injury causation may also result from a combination of shear and tension or shear and bending. In the ejection environment, or any time infero-superior buttocks loading is encountered, the pelvis acts predominantly as an intermediate structure in transmitting loads to the lower spine. Should pelvic fractures occur, in addition to the acetabular fractures from femur loading, the rings formed by the ischial and pubic rami are frequently at risk as is diastasis of the pubic symphysis and/or sacro-iliac joints. Based upon the historical escape injury data, the development of a pelvic injury criterion for ADAM is not recommended.

Reports by Fryer and by Payne and Hawker, as mentioned by Combs,^{22,23} indicated extremity injury incidence from wind flail forces ranging from 7% to 9% and rising to 25% under combat conditions. In the retrospective study by Combs²² of ejection injuries from the F-4, there were 43 ejectees out of 399 ejections who sustained extremity injuries for an injury rate of 10.8%. In these 43 ejectees there were 95 extremity injuries.

Extremity injuries in the database were primarily related to the ejection sequence phases of ejection, emergence, and ground encounter. During retraction the leg restraint actuation or inertia reel forces can exert rotational, shear, or bending mechanisms on limbs that have created four fibular spiral fractures and one clavicle fracture²² from the F-4 dual leg garter configuration and shoulder strap harness restraint respectively.

The most frequent extremity injuries are fracture/dislocations associated with proximal joints; simple and compound fractures of long bones; and strain/sprains. Injury criteria are developed for fracture injuries due to axial compression and tension associated with bending or rotational stress. This choice is based on the assumption that protection of these structures will also afford protection for proximal joints if those joints are positionally maintained within normal ranges of motion.^{50,51}

REFERENCES FOR SECTION 3:

12. The Abbreviated Injury Scale, 1990 Revision. Des Plaines, IL, Association for the Advancement of Automotive Medicine, (1990).
13. Baker, S.P., O'Neill, B., Haddon, W., Long, W.B. The Injury Severity Score: A Method for Describing Patients with Multiple Injuries and Evaluating Emergency Care. *J Trauma*, 14, 187-196 (1974).
14. Aircrew Automated Escape Systems (AAES). In-Service Usage Data Analysis, Volume 1. Papers Presented at the 21st Annual Survival and Flight Equipment Association Symposium held on November 5, 6, 7, 8, 1983 in San Antonio, Texas. NAVWESA-1-83-Vol 1.

15. **Aircrew Automated Escape Systems (AAES), Volume 2. In-Service Usage Data Analyses Program Symposium held on October 6, 7, 8, 1981 at Norfolk, VA, Naval Air Systems Command, Naval Safety Center, 1981.**
16. **Aircrew Automated Escape Systems (AAES), Volume 3. In-Service Usage Data Analyses Program Symposium held on October 6, 7, 8, 1981 at Norfolk, VA, Naval Air Systems Command, Naval Safety Center, 1981.**
17. **Aircrew Automated Escape Systems (AAES), Volume 4. In-Service Usage Data Analyses Program Symposium held on October 6, 7, 8, 1981 at Norfolk, VA, Naval Air Systems Command, Naval Safety Center, 1981.**
18. **Aircrew Automated Escape Systems (AAES). In-Service Usage Data Analysis Program. Papers. Presented at the 17th Annual Fallsafe meeting held on February 8-12, 1982 in Corpus Christi, TX, Naval Regional Medical Center, 1982.**
19. **Mossley, H.G. Aircraft Accident Injuries—a Review of Over 2,000 Cases. Presented at the 28th Annual Meeting of the Aerospace Medical Association, Denver, CO, May 6-8, 1957. Norton AFB, CA, Aeromedical Safety Division, 1967.**
20. **Lewis, S.T. Ejection Injuries in Southeast Asia Prisoner of War Returnees. Presented at the 12th Annual Symposium of the Flight and Safety Equipment Association, Las Vegas, NV, September 8-12, 1974. Canoga Park, CA, SAFE Association, (1974).**
21. **Hearon, B.F. F/FB-111 Ejection Experience (1967-1980). Part II. Summary of Accident Investigation Reports. AFARML-TR-81-114, November 1981.**
22. **Combs, S.P. Correlation of Mechanism of Extremity Injury and Aerodynamic Factors in Ejections from F-4 Aircraft. IN: Models and Analogues for the Evaluation of Human Biodynamic Response, Performance and Protection. Neuilly-sur-Seine, France, Advisory Group for Aerospace Research and Development. AGARD-CP-253, A3-1-A-34 (June 1979).**
23. **Combs, S.P. Mechanism of Extremity Injuries Occurring During Ejection from F-4 Aircraft. Proceedings of the 16th Annual Symposium of the Survival and Flight Equipment Association, San Diego, CA, October 8-12, 1978. Canoga Park, CA, SAFE Association, 52-55 (1979).**
24. **Belk, W.F. Limb Flail Injuries and the Effect of Extremity Restraints in USAF Ejections—1971-1978. SAFE J, 10, 18-21 (1980 Summer).**
25. **Delgado, R.C. Limb Flail Injuries in USAF Ejections—1979-1985. Proceedings of the 24th Annual Symposium of the Survival and Flight Equipment Association, San Antonio, TX, December 11-13, 1986. Newhall, CA, SAFE Association, 1-3 (1987).**
26. **Shannon, R.H., Till, A.N. Jr. SR-71 Ejection Experience. SAFE Engineering, 1, 3-6 (1971 4th Quarter).**
27. **Ommaya, A.K., Thibault, L.E. Head and Spinal Injury Tolerance with No Direct Head Impact. Proceedings of the 1973 International Conference On the Biokinetics of Impact (IRCOBI), Bron, France, 311-319 (1973).**
28. **Perl, T.R., Nilsson, S., Planath, I., Wille, M.G. Deformable Load Sensing Hybrid III Face. Proceedings of the 33rd Stapp Car Crash Conference, Washington, D.C., October 4-6, 1989, (Society of Automotive Engineers Proceedings No. P-227). Warrendale, PA, Society of Automotive Engineers, 29-42 (1989).**

29. Planath, I., Nilsson, S., Cesari, D. Facial Fracture Protection Criteria for the Hybrid III Load Sensing Face. *Accid Anal Prev*, 23(1), 95-103 (1991 Feb).
30. Planath, I., Nilsson, S. Testing and Evaluation of a Hybrid III Load Sensing Face. *Accid Anal Prev*, 21(5), 483-92 (1989 Oct).
31. Unterharnscheidt, F.J. Translational Versus Rotational Acceleration: Animal Experiments with Measured Input. Proceedings of the 15th Stapp Car Conference, Coronado, CA, November 17-19, 1971. (Society of Automotive Engineers Proceedings No. P-39). New York, NY, Society of Automotive Engineers, 767-70 (1971).
32. Gennarelli, T.A., Thibault, L.E., Ommaya, A.K. Pathophysiologic Responses to Rotational and Translational Accelerations of the Head. Proceedings of the 16th Stapp Car Crash Conference, Detroit, MI, November 8-10, 1972, (Society of Automotive Engineers Proceedings No. P-45). New York, NY, Society of Automotive Engineers, 296-308 (1972).
33. Gennarelli, T.A. State-of-the-Art of Head Injury Biomechanics: A Review (The George A. Snively Memorial Lecture). Proceedings of the 29th Annual Conference of the American Association for Automotive Medicine, Washington, D.C., October 7-9, 1985. Arlington Heights, IL, American Association for Automotive Medicine, 447-63 (1985).
34. Gennarelli, T.A., Thibault, L.E. Biomechanics of Acute Subdural Hematoma. *J Trauma*, 22(8), 680-6 (1982 Aug).
35. Edwards, W.T., Crowell, R.R., Coffee, M.S., White, A.A. 3d. Mechanisms of Injury in the Cervical Spine. Proceedings of a Special Symposium On Maturing Technologies and Emerging Horizons, New Orleans, LA, November 4-7, 1988. New York, NY, IEEE, 123-9 (1988).
36. Bendjellal, F., Tarriere, C., Gillet, D., Mack, P., Guillon, F. Head and Neck Responses Under High G-level Lateral Deceleration. Proceedings of the 31st Stapp Car Crash Conference, New Orleans, LA, November 9-11, 1987, (Society of Automotive Engineers Proceedings No. P-202). Warrendale, PA, Society of Automotive Engineers, (1987).
37. Kallioris, D., Mattern, R., Miltner, E., Schmidt, G., Stein, K. Considerations for a Neck Injury Criterion. Proceedings of the 35th Stapp Car Crash Conference, San Diego, CA, November 18-20, 1991 (Society of Automotive Engineers Technical Paper No. 912916). Warrendale, PA, Society of Automotive Engineers, 401-11 (1991).
38. White, A.A.3d, Panjabi, M.M. *Clinical Biomechanics of the Spine*, 2nd ed. Philadelphia, PA: J.B. Lippincott, (1990).
39. Kazarian, L.E. Injuries to the Human Spinal Column: Biomechanics and Injury Classification. *Exerc Sport Sci Rev*, 9, 297-352 (1981).
40. Myers, B.S., McElhaney, J.H., Doherty, B.J., Paver, J.G., Nightingale, R.W., Ladd, T.P., Gray, L. Responses of the Human Cervical Spine to Torsion. Proceedings of the 33rd Stapp Car Crash Conference, Washington, D.C., October 4-6, 1989, (Society of Automotive Engineers Proceedings No. P-227). Warrendale, PA, Society of Automotive Engineers, 215-22 (1989).
41. Roaf, R. Study of Mechanics of Spinal Injury. *J Bone Joint Surg [Br]*, 42(4), 810 (Nov 1960).

42. Althoff, B. Fracture of the Odontoid Process. An Experimental and Clinical Study. *Acta Orthop Scand Suppl*, 177, 1-95 (1979).
43. Melvin, J.W., Robbins, D.H., Weber, K., Campbell, K.L., Smrcka, J. Review of Dummy Design and Use. Washington, D.C., U.S. Department of Transportation, National Highway Traffic Safety Administration. UMTRI-85-13, February 1985.
44. Melvin, J.W. The Engineering Design, Development, Testing and Evaluation of an Advanced Anthropomorphic Test Device, Phase 1: Concept Definition. Executive Summary. Washington, D.C., U.S. Department of Transportation, National Highway Traffic Safety Administration. UNTRI-85-8, September 1985.
45. Melvin, J.W., Weber, K, eds. Review of Biomechanical Impact Response and Injury in the Automotive Environment. Final Report June 1983-March 1985. Washington, D.C., U.S. Department of Transportation, National Highway Traffic Safety Administration. DOT-HS-807-042, March 1985.
46. Rotondo, G. Spinal Injury After Ejection in Jet Pilots: Mechanism, Diagnosis, Follow-up, and Prevention. *Aviat Space Environ Med*, 46(6), 842-8 (1975 Jun).
47. Shannon, R.H., Munson, H.G. Spinal Injuries in Nonfatal USAF Aircraft Accidents, 1 January 1968-31 December 1972. Proceedings of the 7th Annual Meeting of the Aerospace Medical Association meeting, Las Vegas, NV, May 7-10, 1973.
48. Viano, D.C. Femoral Impact Response and Fracture. HS-030 744, 1980.
49. St. Laurent, A., Szabo, T., Shewchenko, N., Newman, J.A. Design of a Motorcyclist Anthropometric Test Device. Proceedings of the 12th International Technical Conference on Experimental Safety Vehicles, Goteborg, Sweden, May 29-June 1, 1989. Washington, D.C., U.S. Department of Transportation, National Highway Traffic Safety Administration, 1308-16 (1989).
50. Connors, M.P., Specker, L.J., Jennings, T.J. Development and Evaluation of a Device for the Prevention of Arm Flail Injuries. Presented at Annual Scientific Meeting of the Aerospace Medical Association meeting, Houston, TX, May 23-26, 1983. 178-9.
51. Cummings, R.J., Adams, W.J. Aircrew Windblast Protection Concepts, Development and Evaluation. AFAMRL-TR-80-123, March 1982.

SECTION 4

SENSING AND INSTRUMENTATION REQUIREMENTS

SECTION 4

SENSING AND INSTRUMENTATION REQUIREMENTS

ASSESSMENT OF DATA REQUIREMENTS VS. AVAILABLE SENSOR TYPES

This section considers the data required for injury probability assessment and assesses the availability of sensors or transducers suitable for the acquisition of these data. Additional sensors in specific areas would extend the ADAM capability for regional injury probability assessment. Data acquired by the sensors would serve as input to regional models for injury criteria.

The description of specific data acquisition system modifications required to accommodate any additional sensors is beyond the scope of this report. No recommendation is made for the optimum number of data channels or combination of sensors. Instead, the number of channels required by each sensor or group of sensors has been provided. Basic signal conditioning and power requirements for the sensors will be described in the section entitled INSTRUMENTATION REQUIREMENTS.

The use of the Hybrid III head and neck and the current ADAM configuration is assumed. However, separate USAF efforts for improved neck and limb hardware is recognized and must be assessed for integration requirements before choosing a final instrumentation suite. Channel prioritization considerations and supportable sizing constraints will probably dictate the selection of some smaller subset from among the many alternatives presented here.

Head

Data requirements for the head include translational acceleration near its center of gravity and angular acceleration at relatively high frequencies. ADAM's head and its other body segments that contain accelerometers have $\pm 100\text{-G}$ Entran EGA125-100 damped linear accelerometers.³²

The use of higher range linear accelerometers on the head would allow for better coverage of expected linear head accelerations. Hence, it is proposed that three $\pm 250\text{-G}$ Entran EGAXT-250 damped translational accelerometers be considered. These accelerometers would be more durable in that they have a higher triaxial overrange protection capability than the EGA125 series. They also have a higher usable amplitude bandwidth. The linear accelerometers would be mounted on a block at the head's center of mass that would also contain three Applied Technology Associates (ATA) AAS-01 angular acceleration sensors. The angular acceleration sensors are being developed by ATA from the ARS-01 angular rate sensor that uses principles of magnetohydrodynamics.

The ATA ARS-01 has been installed in Hybrid III heads and tested in sled impacts against padded and unpadded automobile A-pillars³⁴ and in sled impacts against acrylic windshields.³⁵

According to Haffner³³, the angular velocity transducer has been used in crash tests by various automotive manufacturers.

The ARS-01 velocity data has also been digitally differentiated and integrated and compared with angular acceleration and position data. Reference angular acceleration was derived from linear accelerometer arrays and position data was attained from rotary potentiometers used simultaneously with three ARS-01 sensors in pendulum impact tests.³⁴ The overall results from verification tests conducted with the ARS-01 have shown that the sensor can produce accurate angular velocity data that can be differentiated or integrated and provide acceptable angular acceleration or position data, respectively. If extremely high or low frequency signals are to be measured, the ARS-01 would not be appropriate for use.³⁵ However, frequencies of head angular acceleration signals during successful ejection seat tests are expected to be within the useful dynamic range of the ARS-01. In addition, Willems³⁵ has pointed out some improvements that can be made to the current calibration methods being used by the manufacturer to optimize the accuracy of the sensors.

The newer AAS-01 angular acceleration sensor from ATA consists of a modified ARS-01. The built-in electronics of the AAS-01 perform velocity data differentiation. It has been noted that the use of a built-in analog differentiator specifically designed for the velocity sensor (used by the AAS-01) provides angular acceleration data with less noise than that obtained by digitally filtering velocity data after testing.³⁶ Haffner³³ planned verification tests of the AAS-01 with simultaneous output from linear accelerometer arrays in A-pillar-head impact sled tests.

Since the AAS-01 still requires some verification, three ARS-01 could be used instead, requiring digital differentiation of the velocity data after testing. Either approach would be a feasible method of measuring head angular accelerations. With an angular acceleration sensor, three additional channels for the head would produce data that previously was obtained from six- or nine-linear accelerometer arrays. The amount of data processing after testing is also reduced. In addition, the AAS-01 or the ARS-01 do not require specialized signal conditioning hardware such as charge amplifiers used by piezoelectric accelerometers. Either sensor requires ± 15 -volt D.C. excitation with the output being compatible with typical piezoresistive accelerometer data acquisition systems.

Cervical Spine

The human cervical spine or neck, like the thoracolumbar spine, has multiple directions and modes of motion. Its limits of travel are not easily defined. In the ADAM application, the data requirements for the neck would include bending, shear and axial (tensile/compressive) loads applied by the adjoining segments (head and thoracic spine). ADAM uses the Hybrid III upper neck six-axis load cell model 1716 developed by Robert A. Denton, Inc.⁵² This mounts between the upper end of ADAM's neck (approximately C-1 on a human) and the base of the skull and measures shear loads in two directions, axial loads along the neck, as well as moments about three axes. The loads measured are those applied between the neck and the base of the skull.

The capability for neck load assessment could be expanded by using not only the upper neck transducer but also the Hybrid III six-axis lower neck load cell (Model 1794 from Denton, Inc.). This transducer would be installed at the junction of the neck and thoracolumbar spine (between C-7 and T-1 on a human) and would measure the comparable loads applied between the torso and the lower neck. Based on the design of the lower neck load cell and ADAM's lower-neck-thoracic-spine area, it does not appear that major re-engineering of that section would be required to adapt the lower neck load cell. Some loads would be measured by both the upper and lower neck transducers, resulting in some redundancy, but yielding increased comparability with data from other Hybrid III test applications. Use of the lower neck load cell would also help to better define the neck configuration at the base (flexion or extension) and provide some information of compressive loads of the upper thoracic spine.

Thoracolumbar Spine

Data requirements for the thoracolumbar spine involve axial loads along the thoracic spine transmitted by the neck, and bending, axial, and shear or translational loads applied by the torso and/or pelvis to the lumbar spine. The yaw, pitch and roll positions of the torso are also required. ADAM is already equipped with a six-axis load cell model 1914 (from Denton, Inc.) at the lower end of the lumbar spine and two trimmer potentiometers (from Preh Industries) that measure torso pitch and roll.⁵² Most of the required load data can be measured by the lumbar load cell.

The Hybrid III manikin, in addition to using a six-axis lumbar spine load cell, employs a six-axis thoracic spine load cell at the thoracolumbar junction.⁵⁷ This concept may be advantageous since it provides additional data relating to regional loads. The thoracolumbar spine in ADAM is primarily composed of rigid, concentric cylinders with an inner spring.⁵² It extends from the lower neck to the lower lumbar spine where a joint with three degrees of freedom is located. This spine was designed to provide good response to vertical accelerations during critical stages of the ejection sequence. The use of a thoracic load cell in addition to a lumbar load cell in ADAM would provide load data at another spinal region. However, due to the current spine design, this would require major re-engineering of ADAM's thoracolumbar spine. The importance of the additional data does not seem to justify re-designing ADAM's spine to include additional load cells within it. Therefore, further instrumentation of the ADAM thorax is not recommended. However, in order to have a more complete description of the thoracic spine motion, one more potentiometer would be adapted to the lumbar spine joint to measure torso yaw on the pelvis.

Thorax and Pelvis

Injury assessment data requirements for the thorax and pelvis are essentially translational acceleration profiles of both body segments. ADAM is equipped with two three-accelerometer arrays at the chest area and at the pelvis.⁵² The accelerometers are Entran EGA125-100. To improve the survivability and usable amplitude of ADAM's accelerometers, the EGA125 series accelerometers could be replaced with EGAXT accelerometers.

Upper Extremities

Information required for assessing injuries to the upper extremities includes humerus and forearm bone shaft bending, shear and tensile or compressive loads. At the shoulders, distractive (tensile) and impact (compressive) load data are also required. Other possible data required are joint torque at the elbows and shoulders and position of each of these joints about their axes of rotation. Torsional loads in the long bones of the upper extremities might also be considered, but further complicate the instrumentation suite. ADAM's shoulder (sternoclavicular) joints have two degrees of freedom, its shoulder/arm-joints have four degrees of freedom and its elbows have two degrees of freedom.⁵² ADAM is equipped with trimmer potentiometers (from Preh Industries) to measure positions in each of these degrees of freedom. ADAM requires additional sensors to measure the required loads if comprehensive upper extremity injury assessment is contemplated. A more practical possibility may be to simply instrument the humeri for bending loads to assess the probable principal mechanism of upper arm injury while also providing some data relating to shoulder and elbow joint torques. Options for the full complement of sensors are described anyway.

Multi-axis strain gage-based load cells manufactured by Denton, Inc. could be used for load measurements. The same sensor configuration (for load and position) could be used in both right and left arms. Denton multi-axis load cells have been primarily used in Hybrid II and III manikins as well as manikins used for motorcycle rider limb injury/protection testing.^{58,59} They have also been installed on these ATDs at their lower extremities and spines. Moreover, due to the modular and compact design of the transducers, they have potential for use in upper extremities.

Specifically, on ADAM's upper arm or humerus, two load cells could be adapted to each end of the bone shaft. The load cell at the shoulder/arm-joint(upper humerus), would be a modified design similar to the model 1000 used by Daniel and Yost⁵⁸ in the Hybrid II upper tibia or similar to the model 1583 used in the Hybrid III upper tibia. Either of these would measure shear loads in two axes perpendicular to each other and to the longitudinal axis of the bone shaft. It would also measure moments about the shear load axes. Hence, this load cell would measure loads in four axes. The lower humerus load cell would essentially be the same as that of the upper humerus. One of the two cells should have an additional sensitive axis to measure tensile or compressive loads along the humerus. A modified Hybrid III femur load cell model 1914 or a modified Hybrid III lower tibia load cell could be used in the lower humerus. These sensors would measure loads caused by effects of the shoulder-torso or forearm on the humerus.

One more load cell could be installed at the upper forearm, opposite (across the elbow) from the lower humerus load cell. This load cell would also measure two shear forces at the upper forearm, tensile or compressive loads of the forearm and moments about the axes of the shear forces. Thus it would also be a five-axis load cell. If joint torques developed at the elbow and shoulder are of interest, they would be assessed using this load cell and the humerus load cells. This topic is further addressed in the section entitled ASSESSMENT OF THE NEED FOR JOINT TORQUE INSTRUMENTATION.

Lower Extremities

The data requirements for these body segments are very similar to those of the upper extremities: femur and tibia bone shaft bending, shear and axial loads. Also, torsional load data of both (femur and tibia) bones could be considered. Other data that may be required are knee joint torques and position of the hip and knee joints about all their axes of rotation, and position of the ankle about its inversion/eversion axis. The hips of ADAM have three degrees of freedom, the knees and ankles have two degrees of freedom each. ADAM is equipped with trimmer potentiometers for all the hip and knee degrees of freedom and two ring-type single axis load cells at each upper tibia to measure bone shaft torques.⁵²

Since tibia torques are not the only potential load data requirements at ADAM's lower extremities, the existent tibia load cells could be replaced by multi-axis load cells. Multi-axis load cells could also be used for load measurements at other sites of the lower extremities. Both legs would have the same load and position sensor configuration.

As previously mentioned, multiaxial load cells have been used in lower extremities of various test manikins. There are suitable designs that might be adapted for use in ADAM.

Both the femur and tibia in ADAM could contain two load cells at each end of the bone shaft. The upper femur load cell would measure two shear forces and three orthogonal moments (including torsion) while the lower femur load cell would measure two shear forces, two moments about the axes of the shear forces and axial (tensile/compressive) forces along the femur. Both of these sensors would then measure loads in five axes although the upper load cell would measure femur torsion while the lower load cell would measure axial loads for the same bone. The Hybrid III upper and lower femur load cells models 2193 and 1914, respectively might be adapted for use in ADAM's femur.

The lower leg or tibia configuration would be the same as that of the femur using five axis load cells at each end: either a modified model 1000 or a model 1583 would measure upper tibia shear loads in two axes and three orthogonal moments; and at the lower tibia, either a modified lower femur load cell (model 1914) or Hybrid III lower tibia sensor would measure two shear forces, two moments and axial loads along the axis of the tibia. Another feasible (although not as thorough) alternative would be eliminating the lower tibia load cells and adding the axial load data channels to the upper tibia load cells. If this alternative were chosen, each lower extremity would contain three load cells as was the case for the upper extremities. This would eliminate the need for five channels for each lower tibia sensor but would not provide shear and the corresponding moment data at the lower tibias. In any case, if hip, knee and/or ankle joint torques are of interest, they would be assessed using the femur load cells and tibia load cells.

The Hybrid III manikin can use an upper tibia-knee clevis sensor model C-1587 also manufactured by Denton, Inc. This measures axial loads in an axis passing through the knee and ankle joints in the sagittal plane. This axis does not coincide with the axis along the tibia shaft. To provide a more complete assessment of axial loads in ADAM's lower extremities,

especially if considering loads during landing falls, the use of a knee clevis sensor such as the C-1587 could be considered. This would require one more channel per lower leg.

All the load cells for the lower extremities would measure loads caused by effects of the adjoining members to any given bone shaft. One more trimmer potentiometer would be used to measure inversion/eversion position of the ankle. An ankle dorsiflexion/extension potentiometer may not be as critically needed for injury assessment, since ankle sprain is probably more prone to occur about the inversion/eversion axis.

In adapting the above load cells to ADAM's extremities, their size and their effects on mass properties must be considered. The length of the original steel shafts may need to be shortened and/or other lighter materials adapted for use in some segments. Other more frangible materials should not be used because, although the biofidelity of the manikin may be slightly enhanced, its durability and survivability would be degraded. According to Denton⁶⁰, adapting load cells to a manikin's extremities is performed in such a way that the mass properties of each body segment are minimally affected. The sensors are designed to become almost integral parts of the segments to which they are attached.

Appendix C presents an outline of the data requirements versus potential sensors to acquire a complete complement of data. Certain instruments such as the angular acceleration sensors or the transducers at the extremities would also make ADAM more suitable for use in land vehicle collision testing with injury probability assessment.

ASSESSMENT OF THE NEED FOR JOINT TORQUE INSTRUMENTATION

This section describes a possible method to measure torque at important joints in ADAM such as the shoulder/arm-joint and knee without the use of specific torque measurement instrumentation within a given joint.

In this context, joint torque is defined as the torque or moment developed in a joint when associated links or body segments are forced past their limits of motion within the joint or when the links are torqued to rotate about an axis about which they are not normally able to rotate. The former could occur for instance, if the forearm was forced to extend past its turn limit at the elbow (i.e., hyperextension of the elbow) as in Figure 1(a). The latter could occur if the tibia was forced to rotate about the longitudinal axis of a collinear tibia-femur at the knee as in Figure 1(b) or in varus or valgus strain at the knee as in Figure 1(c). Excess of torque or motion in any of these cases would lead to injury.

It was suggested in the previous section that the humerus load cells and the upper forearm load cell could be used to assess elbow and shoulder joint torques, respectively. This is also the case for the femur and tibia load cells for deriving hip and knee joint torques.

In order to demonstrate this concept, consider a simplified two dimensional example as shown in Figure 2(a) where one end of link 1 is attached to link 2 by a revolute joint and is fixed at

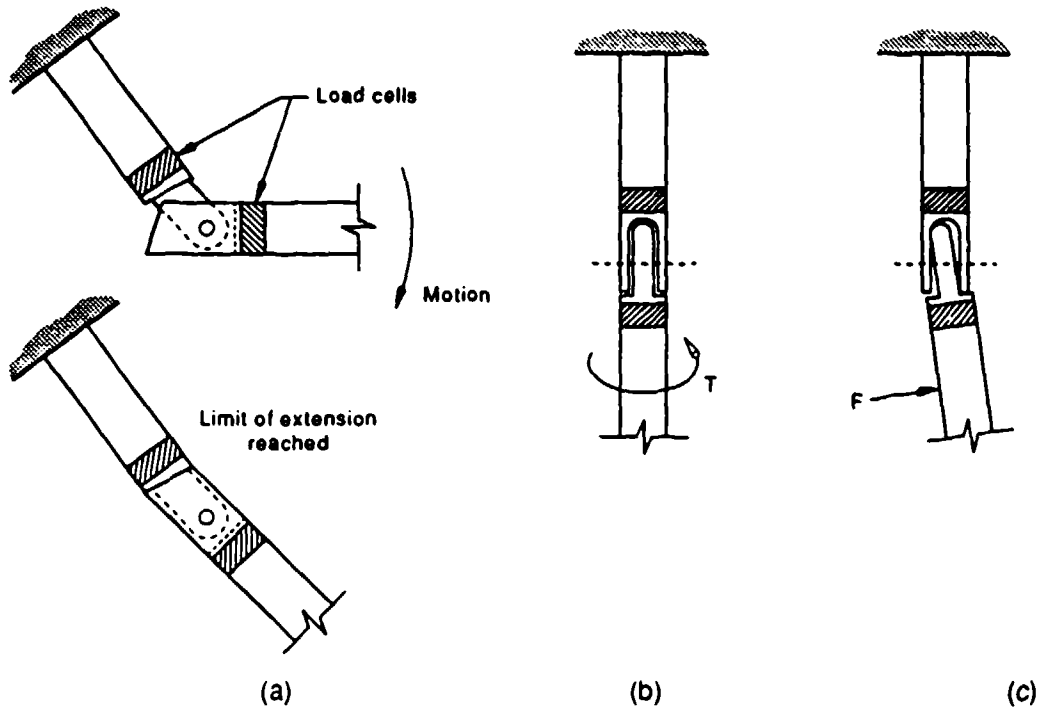

Figure 1. Some possible cases of joint torque.

its other end. Assume link 2 has a limited range of motion at the joint and that a multiaxial load cell is incorporated near the joint. Torque at the joint would be developed by inertial loads of link 2 causing the joint to attempt to hyperextend (beyond its limit of extension) and/or by an external load applied to link 2 to attempt to rotate on an axis about which the joint does not rotate. Figure 2(b) shows the free body diagram of link 2 with possible reactions due to loads from a combination of the two cases above: inertial (mg) and externally applied (P) loads. For the case when only inertial loads of link 2 are affecting the joint, the applied load P is ignored. Assume the load cell is capable of measuring axial, shear and moment loads shown as $(F_{LC})_x$ and $(F_{LC})_y$ and M_{LC} , respectively.

If link 2 is separated in two sections at the load cell as shown in Figures 3(a) and 3(b), the parameters measured by the load cell can be defined. From the free-body-diagram of the lower portion of link 2 (Figure 3(a)), the following is obtained:

$$\begin{aligned} \Sigma F_x &= m(a_2)_x \\ \Sigma F_y &= m(a_2)_y \\ \Sigma M_{LC} &= \Sigma(I_2 \alpha \ \& \ m(a_2))_{LC} \quad (\text{assume ccw to be } +) \end{aligned}$$

where:

- I_2 = moment of inertia of link 2,
- $(a_2)_x$ & $(a_2)_y$ = components of the linear acceleration of link 2,

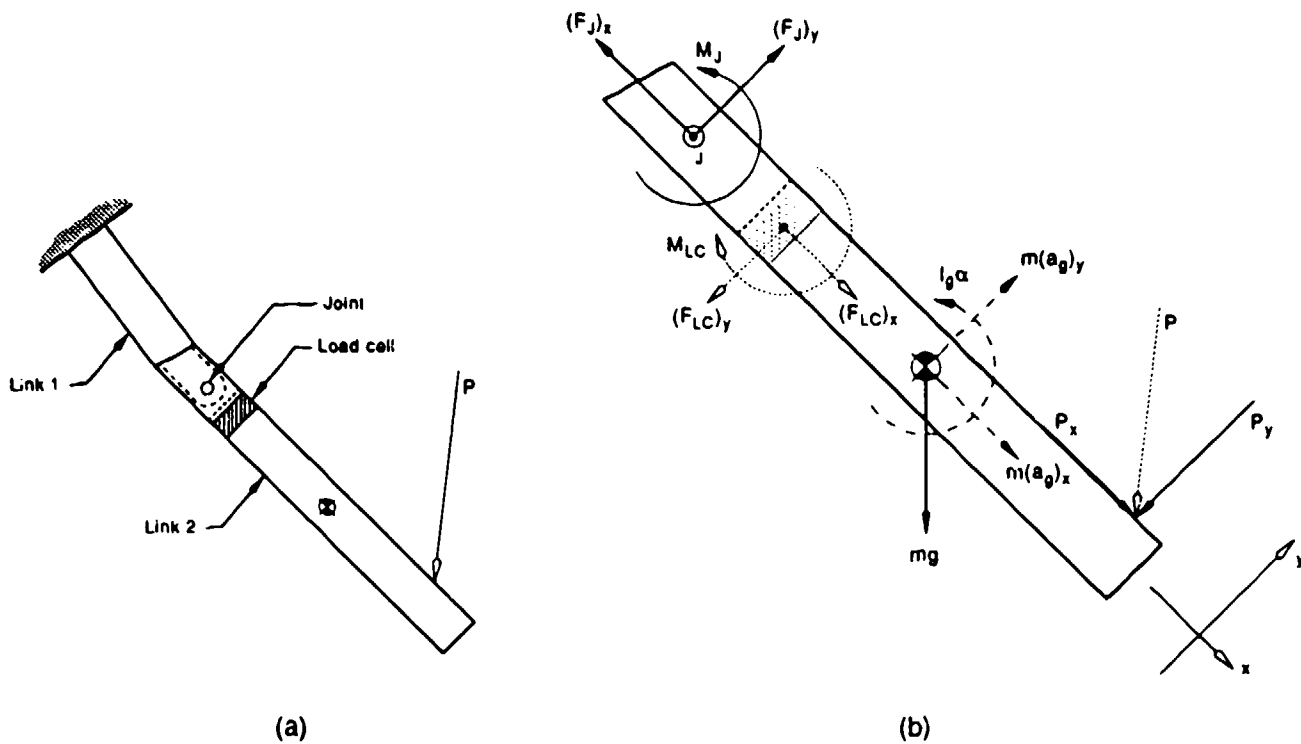

Figure 2. (a) Two links at its maximum extension and with an applied load.
 (b) Free body diagram of link 2.

α = angular acceleration of link 2,

$\Sigma(I_g\alpha \text{ \& } m(a_g))_{LC}$ = moment sum of $I_g\alpha$ and the components of $m(a_g)$ about LC.

Denoting L_1 , L_2 and L_3 as moment arms, the load cell parameters become:

$$(F_{LC})_x = (mg)\sin\theta + P_x - m(a_g)_x \quad (1)$$

$$(F_{LC})_y = (mg)\cos\theta + P_y - m(a_g)_y \quad (2)$$

$$M_{LC} = ((mg)\cos\theta)L_1 + (P_x)L_3 + (P_y)(L_1 + L_2) + I_g\alpha + (m(a_g)_y)L_1 \quad (3)$$

Since the load cell would provide data for $(F_{LC})_x$, $(F_{LC})_y$ and M_{LC} (Equations (1) through (3)) at any given instant, the external force, P could be determined by knowing the mass properties of link 2 as well as the magnitude and direction of its linear and angular accelerations. The effect of additional accelerations on joint torque can also be treated simply as a part of the externally applied force. In addition, from the upper portion of link 2 as in Figure 3(b), the moment at the joint, M_J , could be found from the load cell data.

To determine the moment or torque at the joint J, consider the upper section of the free-body-diagram of link 2 Figure 3(b) and assume that the inertial properties of the mass of the link

within the length L are negligible compared to those of the entire limb. Then, since the load cell measures the loads at any instant of time, the joint torque becomes M_j and can be derived by a simple static analysis as follows:

$$\Sigma F_x = 0$$

$$\Sigma F_y = 0$$

$$\Sigma M_j = 0 \text{ (assume ccw to be +)}$$

$$(F_j)_x = (F_{LC})_x \tag{4}$$

$$(F_j)_y = (F_{LC})_y \tag{5}$$

$$M_j = ((F_{LC})_y)L + M_{LC} \tag{6}$$

Where $(F_j)_x$ and $(F_j)_y$ are the force components at the joint and M_j is the joint torque (Equation (6)).

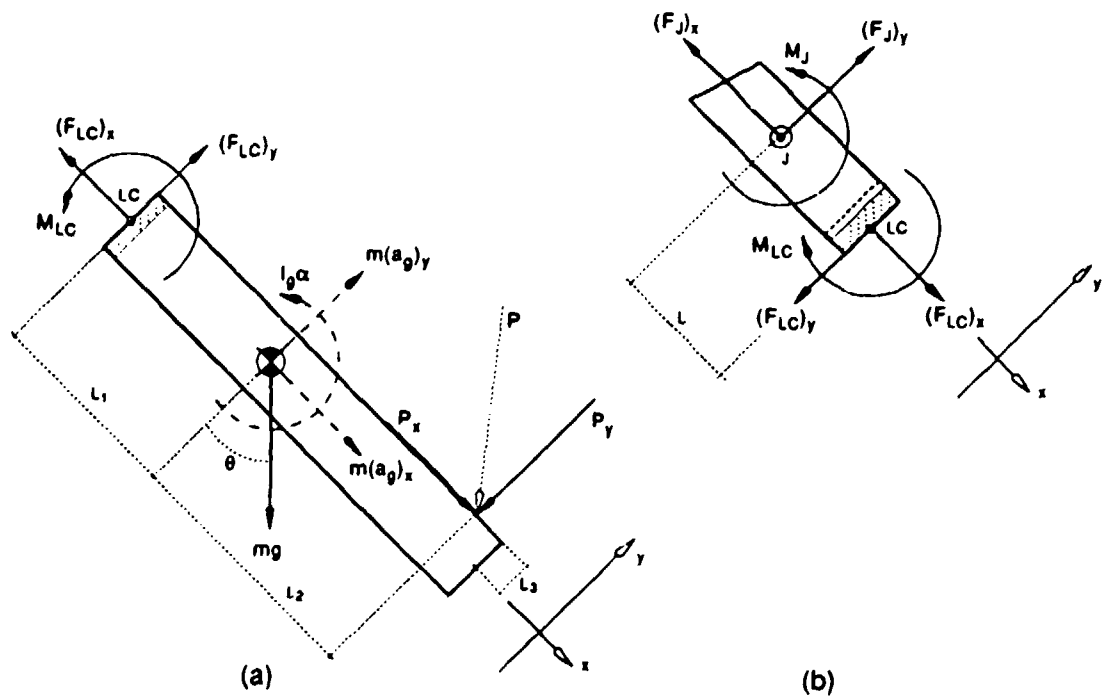

Figure 3. Free-Body-Diagrams for two sections of link 2 at each side of the load cell.

For a three dimensional case, a similar approach would be followed. In general, one multi-axis load cell mounted on a bone shaft as close to the joint as possible would provide sufficient data to determine joint torques. Where feasible, another load cell on the opposite side of the joint attached to the adjoining segment would provide data that may also be used in deriving the joint torque with some redundancy. In this sense, the load cells used in the extremities to measure extremity load parameters also assess joint torques.

INSTRUMENTATION REQUIREMENTS

The instrumentation requirements are described in this section in terms of relevant specifications for the proposed accelerometers, potentiometers and load cells.

Linear Accelerometers

The linear accelerometers proposed are Entran EGAXT series miniature, full-bridge, piezoresistive accelerometers. The head would contain three EGAXT-250 which have a range of ± 250 Gs and sensitivity of 1 mV/G. The chest and pelvis would each have three EGAXT-100 that have a range of ± 100 Gs and sensitivity of 2.5 mV/G. The EGAXT series accelerometers have a triaxial overrange protection of $\pm 10,000$ Gs at any frequency. This would primarily help to protect the accelerometers during handling or during experimental mishaps such as parachute opening failure. All the linear accelerometers would have a 0.7 critical damping factor at 80°F (actual critical damping range from 0.3 to 1), with a minimum of 600 and 510 Hz to a maximum of 1000 and 800 Hz frequency responses for the EGAXT-250 and EGAXT-100, respectively. The damping factor for each triaxial cluster of EGAXTs (head, chest and pelvis) should be custom-matched by Entran to maximize accuracy. All EGAXT series accelerometers are 0.145 x 0.27 x 0.37 inches in size, weigh 0.5 grams and require 15-Volt D.C. excitation. These units are precision-calibrated by the manufacturer and can also be shunt-calibrated prior to testing without removing the units from their mountings providing for good repeatability. Their operating temperature range is -40° to 250° F, this is well within expected operating temperature ranges for ejection seat testing.

Angular Acceleration Transducers

The angular accelerometers proposed are ATA model AAS-01. These sensors consist of a magnetohydrodynamic angular velocity sensor with a built-in analog differentiator. Only three of these sensors would be installed on the head. They have a maximum angular acceleration envelope of 628 rad/sec²/Hz with a frequency response of 0.3 to 400 Hz for a sinusoidal input. That is, at any sinusoid input with frequency in the given range, the maximum angular acceleration that the sensor would be able to detect would be 628 rad/sec² times the input frequency. Their sensitivity is 50 μ V/rad/sec². The AAS-01 has a linear acceleration operating range of 500 Gs in any axis and its overrange protection (survivability range) is 3000 Gs in any axis. The shock overrange is also 3000 gs for a 300- μ s minimum width half-sine pulse. Also the linear acceleration sensitivity of the sensor is less than 0.005 (rad/sec)/G. The AAS-01 uses mercury as one of its components. This sets the minimum operating temperature of the sensor to -30° C, although it can survive temperatures as low as -60° C, while materials used in joining the sensor components limit the sensor's maximum operating range to 50°C. However, the sensor will be able to survive testing site temperatures of up to 100° C. The size of the sensor is 0.80-in diameter by 0.80-in height and it weighs 48 gm. The calibration of the sensor is done by the manufacturer. Due to the design of the sensor, there is no need to recalibrate the sensor during testing if the sensor's survivability limits are not reached. The manufacturer recommends calibrating the sensor only in between a series of tests rather than prior to each test.

Potentiometers

ADAM's potentiometers are trimmer pots manufactured by Preh Electronic Industries. These are a cermet design with a temperature coefficient of ± 100 ppm/ $^{\circ}$ C and are 0.4 x 0.46 x 0.25 inches. They are mounted on a printed circuit board to facilitate installation. The pots are actuated by 2 mm screwdriver type blades mounted on the moving portions of the joints. ADAM has potentiometers at the following joints:

Hips	2	x	3	degrees of freedom	=	6
Knees	2	x	2	degrees of freedom	=	4
Shoulders	2	x	3	degrees of freedom	=	6
Upper arms	2	x	1	degree of freedom	=	2
Elbows	2	x	1	degree of freedom	=	2
Forearm	2	x	1	degree of freedom	=	2
Lumbar	1	x	2	degrees of freedom	=	2
Sternoclavicular	2	x	2	degrees of freedom	=	4

There are currently 28 potentiometers and it is suggested to add one at the lumbar spine joint to measure lumbar spine yaw position and two for measurement of ankle inversion/eversion position. Other similar and feasible models would be: Spectrol Model 142 Bushing or Servo type mount, 100 to 1,000 ohms or Ohmite Type AB or AS Potentiometers, 100 to 1,000 ohms.

Load Cells

The proposed load cells are manufactured by Robert A. Denton, Inc. The neck would use models 1716 and 1794 and the lumbar spine, upper and lower extremities would use models 1000, 1583, 1914, 2193 and C-1587. As mentioned, some modifications would be needed for the load cells used in the extremities; however, they would have the following general specifications:

Calibration - May be shunt calibrated prior to each test without being dismantled.

Shock - No specific limits available; however, according to Denton,⁶⁰ the ruggedness of the transducers is analogous to that of very stiff springs. They are highly durable.

Static overrange - Fifty percent of full scale.

Temperature range - The working range is 0 $^{\circ}$ F to +150 $^{\circ}$ F.

Nominal sensitivity range - 1.5 mV to 2 mV per Volt of excitation for a given sensor capacity. For instance, in the upper neck load model 1716, the capacity for F_x is 2000 lbs and its sensitivity is 1.663 mV per Volt. Assuming 10-Volt excitation, the sensitivity in terms of millivolts per pound would be 16.63 mV over 2000 lbs or 0.0083 mV/lbs.

Typical resonant frequency - Nominally 600 Hz. This may vary depending on where they are mounted.

Weight - Nominally two pounds for a five channel transducer. Denton, Inc. designs the transducers so as to avoid as much as possible affecting mass properties of the member(s) to which they are attached. Sensors for the upper extremities would be modified lower tibia sensors with added channels that would make them slightly heavier than the current two pound tibia load cells.

Incorporation of all potential extremity load cells may not be desirable based on possible effects on overall manikin weight as well as extremity weight and moments of inertia.

REFERENCES FOR SECTION 4:

52. Bartol, A.M., Hazen, V.L., Kowalski, J.F., Murphy, B.P., White, R.P. Jr. Advanced Dynamic Anthropomorphic Manikin (ADAM). Final Design Report. AAMRL-TR-900-23, March 1990.
53. Haffner, M. NHTSA Office of Crashworthiness Research., December 16, 1991. Telephone communication.
54. Laughlin, D.R. A Magnetohydrodynamic Angular Motion Sensor for Anthropomorphic Test Device Instrumentation. Proceedings of the 33rd Stapp Car Crash Conference, Washington, D.C., October 4-5, 1989, (Society of Automotive Engineers Proceedings No. P-227). Warrendale, PA, Society of Automotive Engineers, 53-6 (1989).
55. Willems, G. A Detailed Evaluation of the ATA Angular Motion Sensor in Realistic Simulated Crash Environments in Proceedings of the 35th Stapp Car Crash Conference, San Diego, CA, November 18-20, 1991. (Society of Automotive Engineers Proceedings No. P-251). Warrendale, PA, Society of Automotive Engineers, 334 (1991).
56. Laughlin, D. Applied Technology Associates, November 18, 1991. Telephone communication.
57. Denton, R. Transducers Drawings and Specifications Catalog. 1991.
58. Daniel, R.P., Yost, C.D. The Design and Experimental Use of a Chest Load-Distribution Transducer and Force-Indicating Legs for the Part 572 Dummy. IN: Proceedings of the 25th Stapp Car Crash Conference, San Francisco, CA, September 28-30, 1981, (Society of Automotive Engineers Proceedings No. P-97). Warrendale, PA, Society of Automotive Engineers, 397-432 (1981).
59. St. Laurent, A., Szabo, T., Shewchenko, N., Newman, J.A. Design of a Motorcyclist Anthropometric Test Device. Proceedings of the 12th International Technical Conference on Experimental Safety Vehicles, Goteborg, Sweden, May 29-June 1, 1989. Washington, D.C., U.S. Department of Transportation, National Highway Traffic Safety Administration, 1308-16 (1989).
60. Denton, R. Robert A. Denton Inc., December 11, 1991. Telephone conversation.

SECTION 5

FORMULATION OF INJURY PROBABILITY ASSESSMENT CRITERIA

SECTION 5

FORMULATION OF INJURY PROBABILITY ASSESSMENT CRITERIA

HEAD

Literature Review

Detailed reviews of experimental and theoretical bases for the development of human head injury criteria are available from a number of sources. Several of these are noted in the literature search listings. Noteworthy recent reviews include the excellent chapter on the head by Prasad, Melvin, Huelke, King, and Nyquist in the Review of Biomechanical Impact Response and Injury in the Automotive Environment edited by Melvin and Webber.⁶¹ Another useful review is available in The Biomechanics of Trauma, edited by Nahum and Melvin, published in 1985. Other very useful perspectives can be found in the chapter on "Head and Neck Injury Criteria and Tolerance Levels" by Goldsmith and Ommaya in The Biomechanics of Impact Trauma edited by Aldman and Chapon, published in 1984. A comprehensive and all-inclusive review will not be attempted here. However, several noteworthy observations will be provided as a background for the head injury criterion to be advanced.

The first step in specifying an injury criterion for the head requires that the injury be well defined. Based upon the material presented in Section 3 of this document, head injuries for ADAM will be defined in general terms largely on the basis of functional disturbances, with the criterion being designed to discriminate intracranial injury as well where it occurs at levels below those necessary to produce functional disturbances. Specifically, the injury against which the criterion is being established would be functional disturbance (concussion) or intracranial anatomic injury produced from generalized proximate impact to a protected head involving both translational and rotational acceleration components.

A criterion for a generally defined injury must still be based upon the parameters that drive the mechanism by which the injury is produced. It is noteworthy that the available human tolerance literature has not arrived at agreement upon a single mechanism for functional or anatomic head injury. Attempts to elucidate a mechanism have generally revolved around one of three principal types of approaches involving human materials, non-human animal materials, and inanimate models. Each of these approaches will be briefly reviewed in the following paragraphs.

One of the earliest approaches to defining tolerance for human head impacts involved the use of human heads of living volunteers or the attached or recently detached heads of human cadavers. Impact severity data have ranged from subjective assessments and high-speed photography to measurements of free-fall drop heights, deformation of impacting surfaces, and acceleration measured by accelerometers. Accelerometers have typically been mounted by straps to the heads of volunteers or mounted to appliances fitted to the teeth of the volunteers. Accelerometers have been screwed to the skulls of cadavers or affixed by other means. The

bulk of the quantitative human test data consists of measurements made by linear accelerometers, often in an orthogonal triad instrumenting three axes. More limited amounts of quantitative data have used arrays of linear accelerometers from which short duration estimates of angular motion can be derived and an even more limited data set involving actual measurement with angular acceleration or angular velocity transducers.

Relatively few studies have involved the imposition of proximate impact to the heads of volunteers. Some early work involved helmeted volunteers dashing their heads against stone walls and then describing the experience. Lombard conducted pendulum impacts to the helmeted heads of volunteers.⁶² Other studies have assessed boxing blows to the head. However, most quantitative volunteer head impact data relates to whole body acceleration events such as impact sled experiments with restrained occupants. In these experiments, proximate impact of the head against an impacting structure has been uncommon or observed only on rebound. In those cases where an impacting structure was applied, the head was typically placed against the structure prior to the impact as in a rear-impact (plus G_y) impact with a headrest. Peak head accelerations have been routinely tolerated by volunteer human subjects in the range of 20 to 30G with associated head rotations in the range of 90° during the impact as a result of forward flexion of the neck. Limited data is available involving volunteer exposures to head impacts in the neighborhood of 50 to 80G, but these have typically involved less rotation. Velocity changes in these impacts have ranged from approximately 10 to more than 50 m/s. These experiments have been conducted by a number of groups, including those within the US Air Force, US Navy, Wayne State University, University of Michigan, General Motors Research Laboratories, and others.

Head injury tolerance end-points were typically not reached in such experiments. Other use of human data has been based upon the *post facto* analysis of falls by human beings. While velocity change at impact could frequently be estimated, specific head accelerations and pulse shapes could not be reliably estimated. Studies of this type are exemplified by the study by Foust, Bowan, and Snyder.⁶³

Other uses of human material include the large number of cadaver studies that have been pursued at a number of centers. An example is the work by Hodgson and Thomas⁶⁴ that assessed potential for skull fracture. Gurdjian, Roberts, and Thomas used not only drop tests, but also striker tests and made comparisons with experiments with anesthetized dogs.⁶⁵ Some studies have reached the complexity of repressurizing the cerebral vasculature of intact cadaver heads. Studies have also used pressure monitoring devices to assess pressure variations in the fluid around the brain. Use of human cadaver material has allowed supra-threshold impacting with more extensive instrumentation, but necessarily restricts the information available on functional disruptions.

A variety of animal tests has been pursued to assess both functional and anatomic disruptions. Noteworthy in these experiments has been the work of Ommaya and colleagues, and that of Gennarelli and colleagues. These and other authors have explored the production of cerebral concussion and anatomic disruption such as intracranial hematomas and have further delineated

9the variations in functional and anatomic disruptions produced by translational as opposed to angular acceleration events. The 1970 article by Ommaya and colleagues⁶⁶ attempted to scale rotational results with three subhuman primate species to man with a prediction of 50 percent probability of concussion with rotational velocities exceeding 50 radians per second and rotational accelerations exceeding 1,800 rad/sec². Ommaya and Hirsch⁶⁷ outlined similar limits and opined that the brain injury potential for an unprotected head is approximately evenly divided between the head rotation stress and the contact phenomena of the unprotected impact. Ommaya and Hirsch noted that the hypothesis originally advanced by Holbourn in 1943 that translational accelerations were noninjurious, with rotational acceleration being the only dangerous stress, was not well founded. Unterharnscheidt discussed apportionment of injury potential between translational and rotational acceleration based upon results of animal experiments in both cats and monkeys.⁶⁸

Gennarelli and colleagues have performed extensive work on animal models demonstrating that concussion could be produced by rotational acceleration, while pure translational acceleration at apparently corresponding severity levels failed to produce concussion.⁶⁹

Other kinds of experimental surrogates have included various anthropometric test devices. These have typically been constructed based upon mathematical models attempting to replicate dynamic behavior of humans or other human surrogates such as unembalmed cadavers. By their nature, these experiments with anthropometric test devices have been generally unhelpful in elucidating functional injury mechanisms or tolerance levels. Rather, they have typically been used in measuring variations in dynamic response as a function of protection system design.

"Tests" of a sort have also been carried out using computer-based mathematical models. These models typically have not been helpful in defining injury tolerance levels either, but have been used in some cases in a manner analogous to the use of anthropometric test devices and also for exploration of physical behavior of the modeled human head system under various kinds of acceleration loading in order to deduce information about injury mechanisms.

The area of interest for our current enquiry has to do with the definition of an injury criterion from this mass of information. Not surprisingly, the effort to develop criteria has been a difficult one and remains today an area of considerable controversy across the field of biomechanics. The situation as it presently exists can perhaps be described in terms of various "camps" or "schools".

One school, which might be termed the "regulatory" school, is based upon the historical development from the early Wayne State Tolerance Curve through the Gadd Severity Index and the Japan Head Tolerance Curve to the currently employed Head Injury Criterion advanced by Versace.⁷⁰ These approaches initially used a tolerance curve based upon cadaver skull fracture under specific circumstances to define a curve in which higher tolerance levels were ascribed for shorter duration acceleration events. The later criteria have apparently been related either to skull fracture or to presumed concussive levels which have even been considered by some to

occur at roughly equivalent points. Others disagree. These criteria have in common their basis in a translational acceleration measurement weighted by time.

The Head Injury Criterion is currently employed under Federal Motor Vehicle Safety Standard 208 at a level of 1,000. Some have suggested a value of 1500 under certain circumstances. Despite the fact that the Head Injury Criterion continues to receive regulatory sanction, generally recognized difficulties with the Head Injury Criterion relate in part to non-contact events, long duration events, and the fact that the Head Injury Criterion does not expressly include consideration of angular acceleration. Only the translational component of angular acceleration at the point of measurement is included. Furthermore, despite the fact that the Head Injury Criterion is a time-weighted acceleration criterion, it is based on acceleration level rather than the parameter of strain that is more closely affiliated conceptually with the notion of injury.

A second school might be described as the "viscoelastic" school. A number of significant papers in this area were published at the 14th and 15th STAPP Car Crash Conferences in 1970 and 1971. These models include the J-Tolerance Index, the Effective Displacement Index,⁷¹ the Revised Brain Model based upon the Vienna Institute of Technology Method,⁷² and the Maximum Strain Criterion proposed by Stalnaker and colleagues.⁷³ These models, in general, are viscoelastic approaches, generally including a spring, mass, and damper. In the Maximum or Mean Strain Criterion approach of Stalnaker two masses are used, connected by a spring and damper. These approaches, in general, had the apparent advantage that they were related to strain rather than an acceleration-based parameter. However, they sometimes attempted to model actual brain strains or displacements, rather than an injury occurrence function, using the lumped parameter approach. The Mean Strain Criterion approach used actual strain or natural frequency measurements of impacted tissue.⁷⁴ An article by Melvin, et al in 1975 showed the incorporation of a torsional spring-mass-damper in conjunction with two other masses having separate spring-dampers.⁷⁵

A third school, represented by the work of Ommaya and also by Löwenhielm might be termed the "angular acceleration" school. While their work does not imply that angular acceleration is the only stress of significance, proposals for injury criteria in this area have tended to center upon separate angular acceleration limits, sometimes associated with a time or angular velocity consideration. Ommaya's earlier limit of 1,800 rad/sec² has been more recently refined to allow accelerations up to 4,500 rad/sec² for velocity changes less than 30 rad/sec with a graded set of injury criteria from 1,700 to 4,500 rad/sec² for angular velocity changes greater than 30 rad/sec. Forty-five hundred rad/sec² in this setting would correspond to relatively severe brain injury.⁷⁶

A final school might be termed the "finite element model" approach. Relatively simple concentric spherical shell models up to complex representations of brain and skull geometry have been proposed by a number of authors, including Liu, Chan, Khalil and Hubbard, Shugar, and Ward and colleagues. Bases for these models often included computations or measurements based upon pressure changes in the fluid surrounding the brain. It has been proposed that head injury criterion development lies in the direction of more detailed and precise finite element models of the skull and brain with precision being visualized down to the level of modeling

individual blood vessel responses. Such models necessarily have to assess displacements, traveling waves, and other phenomena across relatively complex geometrical structures and boundaries. Gennarelli has suggested different injury criteria for different forms of injury.⁷⁷

The upshot of all this is that the regulatory environment continues to use a criterion for head injury that is notably deficient, but the biomechanical community has not yet advanced a compelling substitute that adequately integrates the translational and angular acceleration stressors in a satisfactory manner. The proposed directions involving large multi-body models would appear not to be well designed to allow simple, reproducible, and meaningful injury criteria capable of application to the broad range of impacts sustained operationally. Gennarelli's concern further complicates the issue from the standpoint of an operational criterion only if it is viewed necessary to define operational injury criteria related to each of the various injuries that might be experienced. More practically, it would appear that an injury criterion ought to be defined to address an operationally significant injury level that, based upon Gennarelli's outline, ought to be defined as a concussive level. The proviso should be added that the criterion should also address potentially nonconcussive translational effects that produce potentially debilitating injury such as intracerebral hematoma. The metric being sought is an injury criterion rather than a tolerance curve for a specific form of injury. The following approach is outlined in order to attempt such a formulation. The approach is defined in conjunction with the head injury criterion problem and then, in subsequent sections, philosophically applied in a similar fashion to the other body regions.

Proposed Criterion

The proposed criterion for head injury is a strain function of the output from a viscoelastic lumped-parameter model incorporating translational and angular acceleration stress measured from the ADAM head. Several assumptions and observations must be made clear in establishing the basis for such a criterion. Fundamentally, the form of the criterion is based upon the observation that higher values of translational or angular acceleration can be tolerated when the effective duration is reduced below some critical value. Therefore, the tolerance to concussive or non-concussive but yet significant head injury appears to have the form of the strain response of a linear, second-order, single degree-of-freedom, lumped-parameter, viscoelastic system. Such a system and its strain response is shown in Figure 4. If a square wave acceleration pulse is applied to the base of this model, the maximum deflection of the mass varies as a function of the duration of the pulse. The magnitude dependence on pulse duration for square wave acceleration pulses necessary to produce a given deflection of the mass relative to its base is plotted on logarithmic axes in the graph of Figure 4. For long duration pulses, the strain is determined by the magnitude of the acceleration. As the pulse duration becomes shorter, a point is reached at which increasing acceleration magnitudes are required to produce the same strain. This, in effect, implies an acceleration limit for long duration pulses and a velocity change limit for short duration pulses. This characteristic of typical human injury tolerance is the basis for the shape of such curves as the Wayne State Tolerance Curve and necessitates time-weighting or minimum pulse widths for simple acceleration-based criteria.

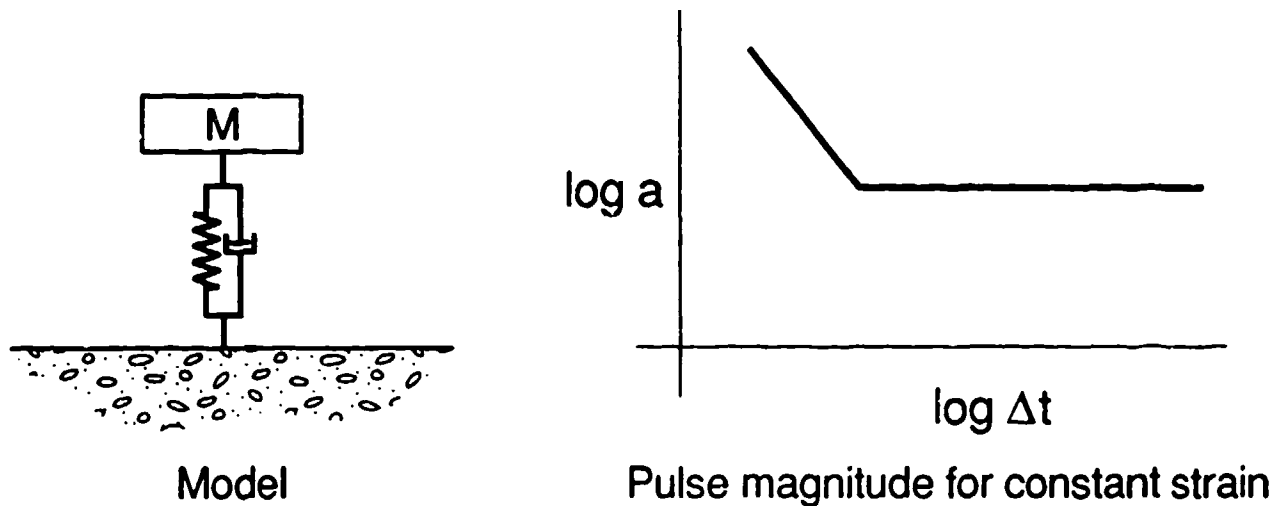
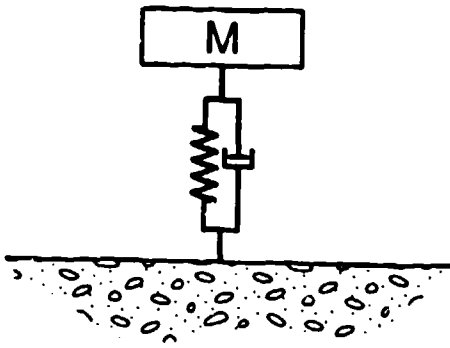

Figure 4. Second order linear single-degree-of-freedom viscoelastic system.

The simple model of Figure 4 can be extended to three dimensions in the manner diagramed in Figure 5. In effect, the mass of Figure 5a is extended into a spherical shell and the base is collapsed into a massless point as shown in Figures 5b and 5c. Figures 5c through 5g illustrate the extension of the spring and damper into a three dimensional viscoelastic medium. Accelerations measured for the point are then evaluated on the basis of the strain produced that is simply the maximum change in radius between the point and any point on the shell. Theoretically, anisotropic spring constants and damping ratios could be employed along different axes, yielding the potential for the modelled sensitivity to injury to be different along different directions.

Thus far, the model has been based purely on translational accelerations. However, angular accelerations can be treated in a perfectly analogous fashion. In effect, angular acceleration is measured at the base or point inside the sphere and angular strain is assessed for a viscoelastic system using angular or torsional springs and angular or torsional dampers. The approach is illustrated in Figures 6 and 7. In a manner analogous to that with the translational accelerations, the simple angular strain model of Figure 6a can be employed in three orthogonal planes as shown in Figures 6b through 6d. Each model is "extended" about an appropriate axis as shown in Figure 7 to achieve a three dimensional representation.

The result of such a modelling approach allows translational and angular accelerations measured in the ADAM head to be evaluated for their maximum translational and angular resultant strains. Based upon the observations that injury thresholds follow a second-order viscoelastic system



a

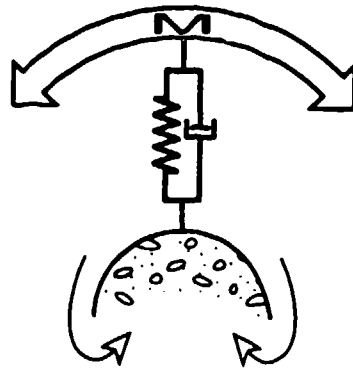

b

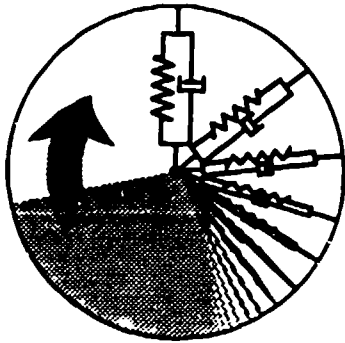

c

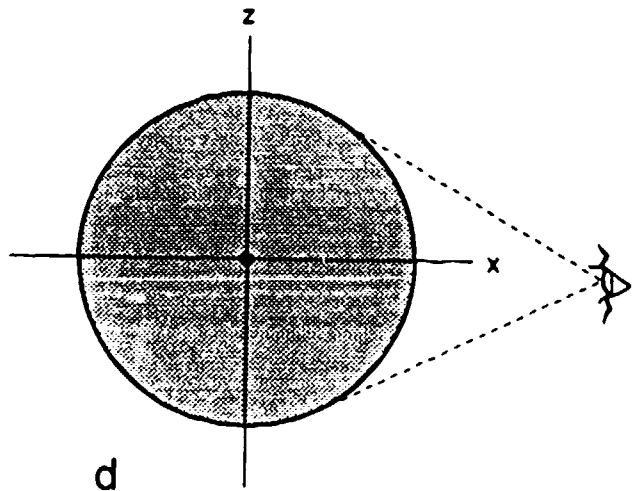

d

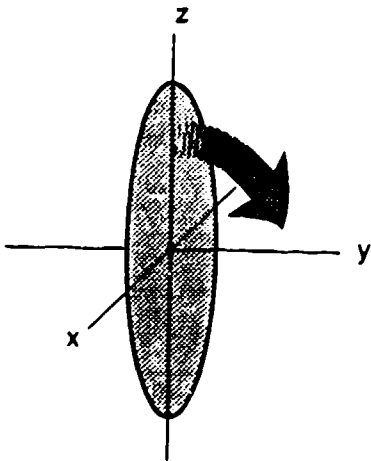

e

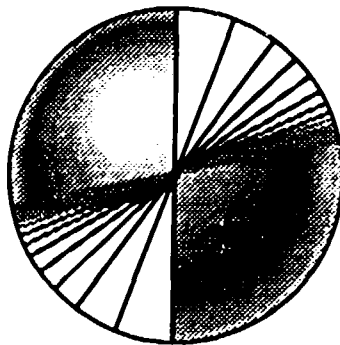

f

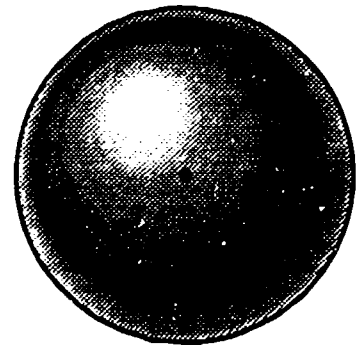

g

Figure 5.

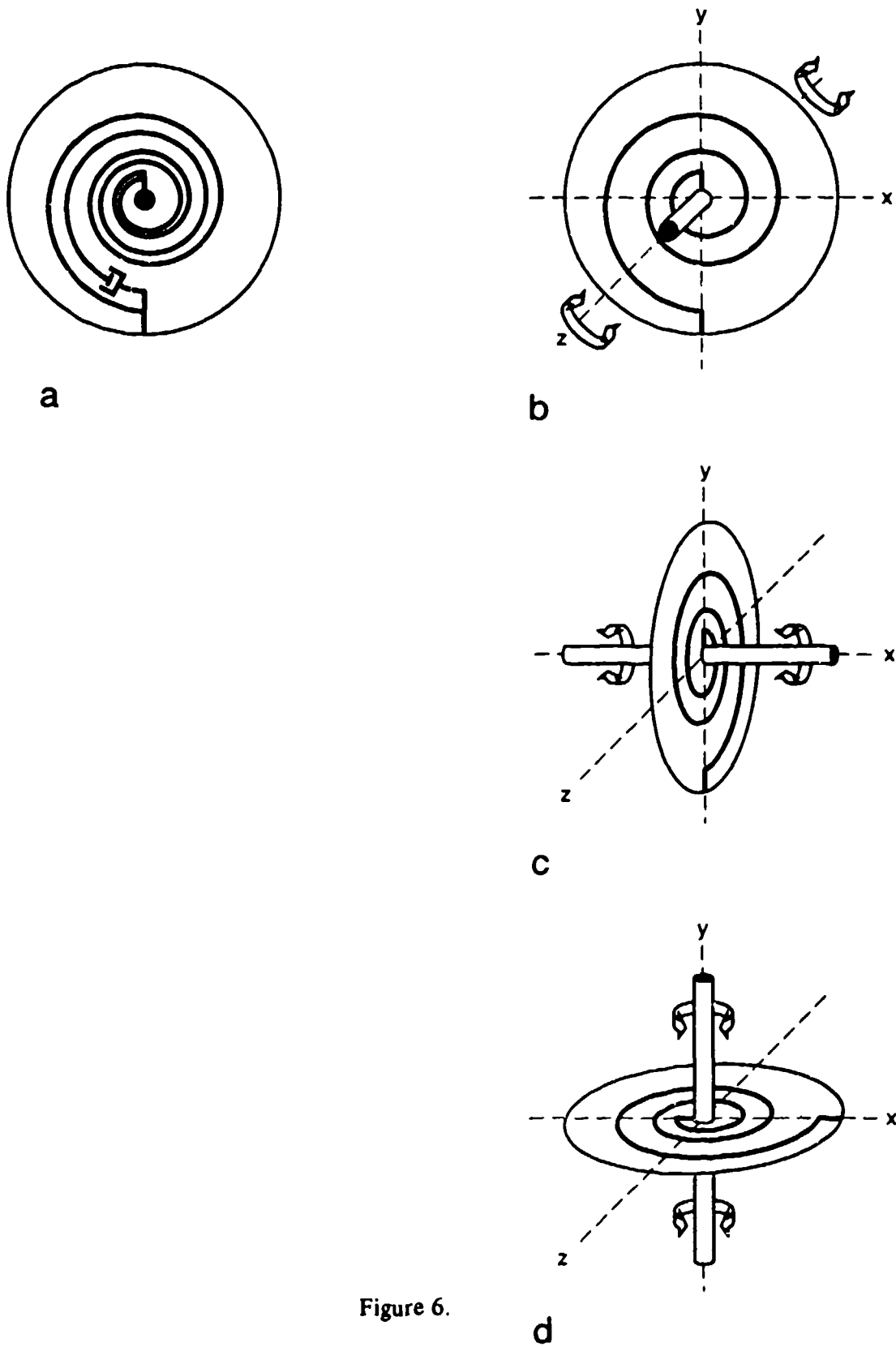

Figure 6.

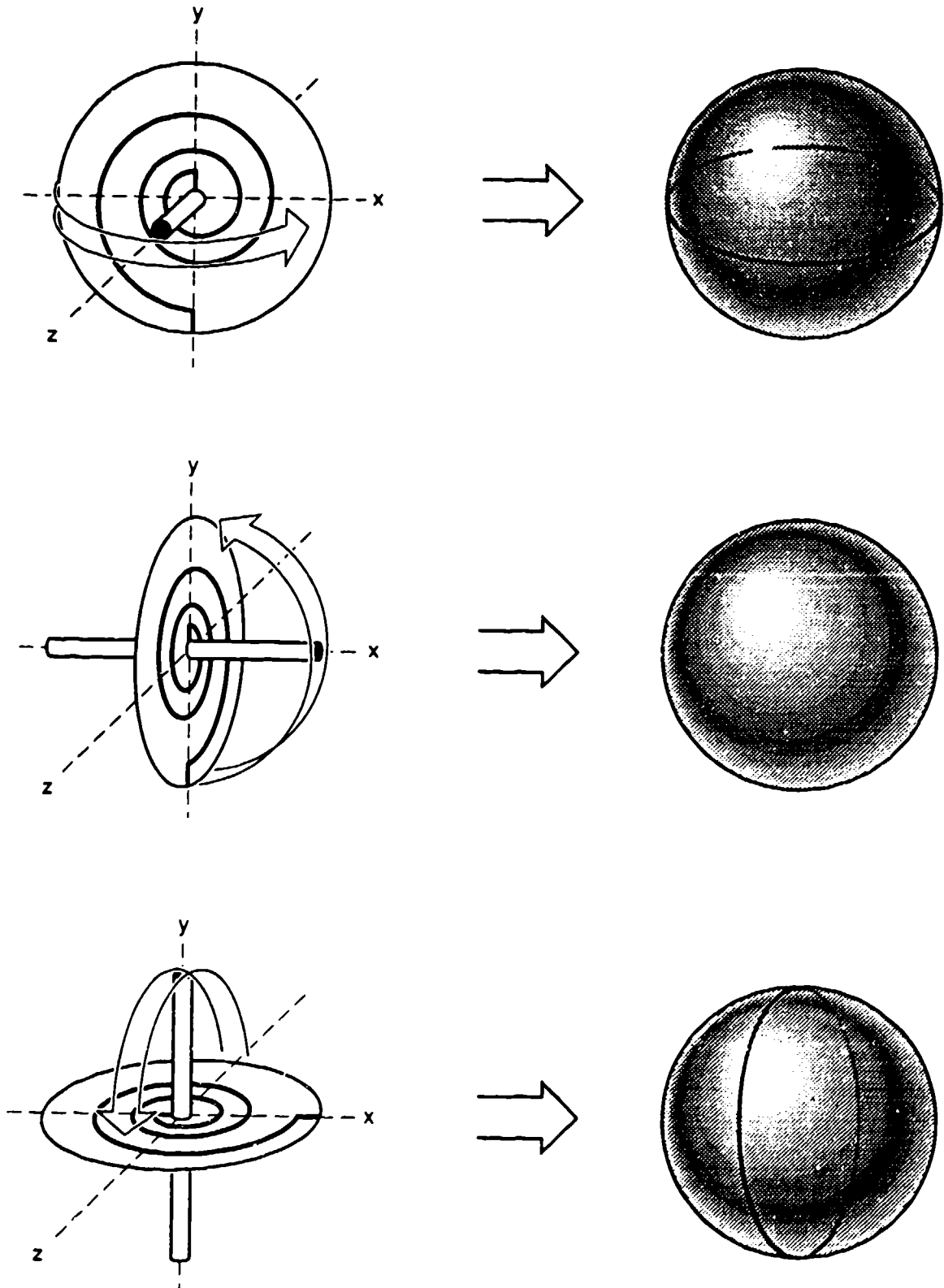

Figure 7.

response, the proposed model should have the requisite form to model acceleration-related injury thresholds in terms of viscoelastic strain. However, it is important to note that the strain defined by the injury criterion does not necessarily relate to a measured or measurable strain in either the skull or brain of a human exposed to impact. In fact, the effective strain tolerance is a number without anatomical significance that varies depending upon the values for mass, spring, and damper which, in turn, depend upon the transition point between acceleration and velocity dependence for the injury criterion. Any mass value could be chosen and a suitable coefficient, spring constant, and damping coefficient defined to produce a strain response to match experimentally derived injury characteristics, so long as those characteristics exhibit the behavior of a second-order, single degree-of-freedom system. Since various mechanisms may be involved that relate to different anatomic structures having different masses in the human head, the lumped-parameter approach implies that the resultant strain may not have physically relatable meaning even if the mass selected is typical of a human head mass.

Also noteworthy in this development is the mathematical coupling of translational and rotational stresses that may correspond to physical analogs in real injury mechanisms. For example, angular acceleration stress may be more significant from an injury mechanism standpoint under conditions in which translational acceleration stress is also being applied to the same head. Conceptually, a brain that is "sloshed" to one side of the skull by translational acceleration stress may be more subject to injury as a result of rotational stresses that further aggravate its motion or contacts with skull surfaces.

Such an approach is amenable to mathematical representations in which the motion of a mass both translationally and rotationally may be computed based upon an arbitrary acceleration input. However, such equations in Cartesian space become significantly complicated. If this complexity led to better understanding of the underlying mechanisms, such an approach might prove valuable. However, initial assessments of a rigorous mathematical simulation of this sort appear not to be sufficiently informative to justify their complexity. A general approach along this line is presented for information in Appendix D.

A simpler approach is shown in Figure 8. In this case, translational accelerations along the three orthogonal axes are independently used as inputs into a single degree-of-freedom system. The parameters for the systems for X, Y, and Z could easily be adjusted independently based upon differences in injury sensitivity along the three axes. Adjustments would be fashioned in such a way that the resulting strain would be proportional to injury likelihood for strains over the same range in each axis. The resulting strains along each axis could then be vector summed into a translational strain vector in three dimensions. Similarly, for rotational acceleration, single degree-of-freedom models would be used for each axis, in this case conceptually representing torsional springs and torsional dampers. Mathematically, however, they are treated similarly. Once again, parameters for the angular strains about each axis could be adjusted independently based upon susceptibility to rotational acceleration stress about each of those axes. Once again, an effective rotational strain vector could also be constructed.

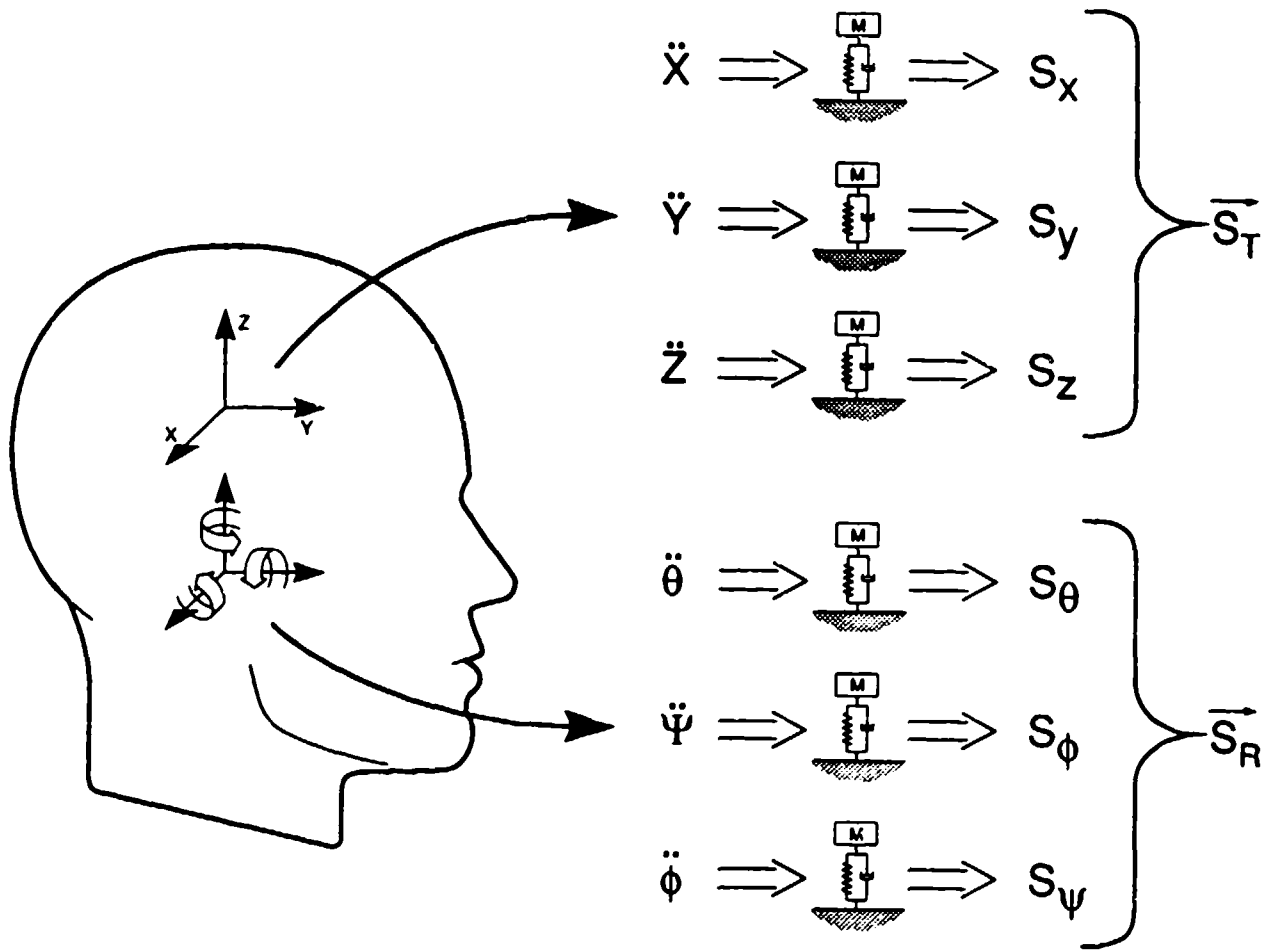

Potential Criteria

$$|\vec{S}_T|_{MAX}$$

$$|\vec{S}_R|_{MAX}$$

$$|\vec{S}_T \times \vec{S}_R|_{MAX}$$

Figure 8.

It should be noted, however, that the representation shown in Figure 8, if used independently, does not effectively assess the potential coupling of translational and rotational stress applied simultaneously. To do this, a multiterm injury criterion could ultimately be constructed using weighting coefficients and the vector cross product between the translational strain vector and the rotational strain vector. The vector cross product assesses the interaction between translational strain and moments about axes perpendicular to that strain. The final proposed injury criterion would have the form:

$$\text{Form of Head Criterion} = \left[\left(\frac{|\bar{S}_T|_{MAX}}{S_T \text{ Limit}} \right)^2 + \left(\frac{|\bar{S}_R|_{MAX}}{S_R \text{ Limit}} \right)^2 + \left(\frac{|\bar{S}_T \times \bar{S}_R|_{MAX}}{\text{Cross Product Limit}} \right)^2 \right]^{1/2} \quad (7)$$

For near-term applications, currently available data may only allow an approach which separately utilizes the translational strain and the rotational strain terms. Separate criteria could, therefore, be defined for these stresses until such time as sufficient data could be established to allow the appropriate combination of the two stresses with their interaction term as demonstrated in Equation (7).

Appropriate recognition should also be made of the significant basis of this approach on previous work by Stech and Payne⁷⁸ and subsequent extensions of that work by Brinkley and Schiffer, as well as several subsequent articles by Brinkley and colleagues. The Stech and Payne article was foundational in defining the approach in 1969 with principal application to spinal injury. The Dynamic Response Index (DRI) has proven to be a useful criterion for assessing spinal injury. This will be discussed further in the section on the thoracolumbar spine. It should be recognized, however, in conjunction with the current discussion of the head criterion, that the DRI has demonstrated meaningful correlation not only with the occurrence of a range of spinal injuries but also with the probability of spinal injury. Increasing values for the DRI have been correlated with increasing spinal injury incidence over a range of aircraft ejection seats having varying pulse shapes and magnitudes. It should be noted that the DRI was defined as a normalized peak strain or force developed within a system comprising a mass supported by a spring-damper combination (Kelvin Element) from an accelerating base. The current definition transitions to a pure maximum deflection or strain criterion because of the conceptual relation of strain to tissue injury and the proposed employment of strain models for other body regions.

Noteworthy in the DRI application is the correlation with spinal injury occurrence, despite the variations along the thoracolumbar spine in location of spinal injury and the variation in spinal injury mechanisms depending upon occupant position. This observation provides cause for some optimism in creating a similar injury criterion suitable for the description of the multiple injury modes exhibited in the head. Principal approaches thus far advocated by Brinkley relate largely to the definition of whole body injury criteria by extensions of the Z-axis DRI spinal injury application to a proposed multi-axis whole body injury descriptor. The current approach departs from the thrust of that development by separately measuring accelerations, angular accelerations

and, as defined in later sections, forces and torques in a similar manner for separate body regional injury assessment.

It should also be noted that the constant strain response curve for square wave inputs demonstrated in Figure 4 does not represent a tolerance curve in general. For one thing, the curve is not referenced to a particular injury type but, rather, to the occurrence of injury in the head of a given category of significance. From a mathematical point of view, however, an additional difference derives from the fact that Figure 4 is a constant strain curve only for square waves. As can be seen in Figure 9, different waveform shapes with similar durations will require different peak acceleration values in order to produce the same constant peak strain. The definition of the criterion relates not to an acceleration limit or a velocity limit at all. Instead, the criterion is simply a maximum strain number which may be produced by a variety of pulse shapes or magnitudes. This allows the significance of different acceleration waveforms to be compared on the basis of peak the strain which they produce in a viscoelastic model. This, therefore, is the basis for assigning a criterion which may accommodate a range of strain values.

This approach may be expected to work reasonably well for injury to structural elements and even to soft tissue if attention is confined to relatively short duration events. However, observations by Viano and Lau⁷⁹ may require some modification in the way that maximum strain for soft tissue is assessed, particularly if a broad range of frequency response is required. This approach would alter the treatment of strain magnitude by assessing strain velocity simultaneously. In other words, the same amount of strain would have different potential significance in soft tissue depending upon the speed at which the strain was produced. A punch to the abdomen would be appreciated differently than a physician's palpating fingers probing to the same depth. The potential exists to specify a viscoelastic strain criterion for head injury with a modification to Equation (7) being ultimately required to assess the velocity associated with the production of a given strain in order to make the criterion applicable to the brain over a broad range of frequencies.

Several curves are presented to both illustrate the technique and demonstrate its application to a number of sets of experimental data involving both translational and angular accelerations. Figures 10a and 10b present the effects of variations in the model's two parameters, natural frequency and damping ratio. On both figures, the logarithm of the peak input acceleration in G-units is plotted on the ordinate against the logarithm of the acceleration pulse duration which appears on the abscissa. The peak strain for all of the curves in Figures 10a and 10b was held constant at 6.2 mm.

The effect of changing natural frequency is illustrated in Figure 10a, where the damping ratio and peak strain were held constant for three natural frequencies: 50, 75 and 100 Hz. The effect of increasing natural frequency was to increase the apparent stiffness of the system. That is, as natural frequency increases, higher peak accelerations are required to produce the same peak strain. Another effect of increasing natural frequency (decreasing natural period) is to shift the crossover point to the left on the plot of $\log \Delta t$ vs \log peak acceleration. Figure 10b shows the effect of changing the damping ratio while holding the other parameters constant. Increasing

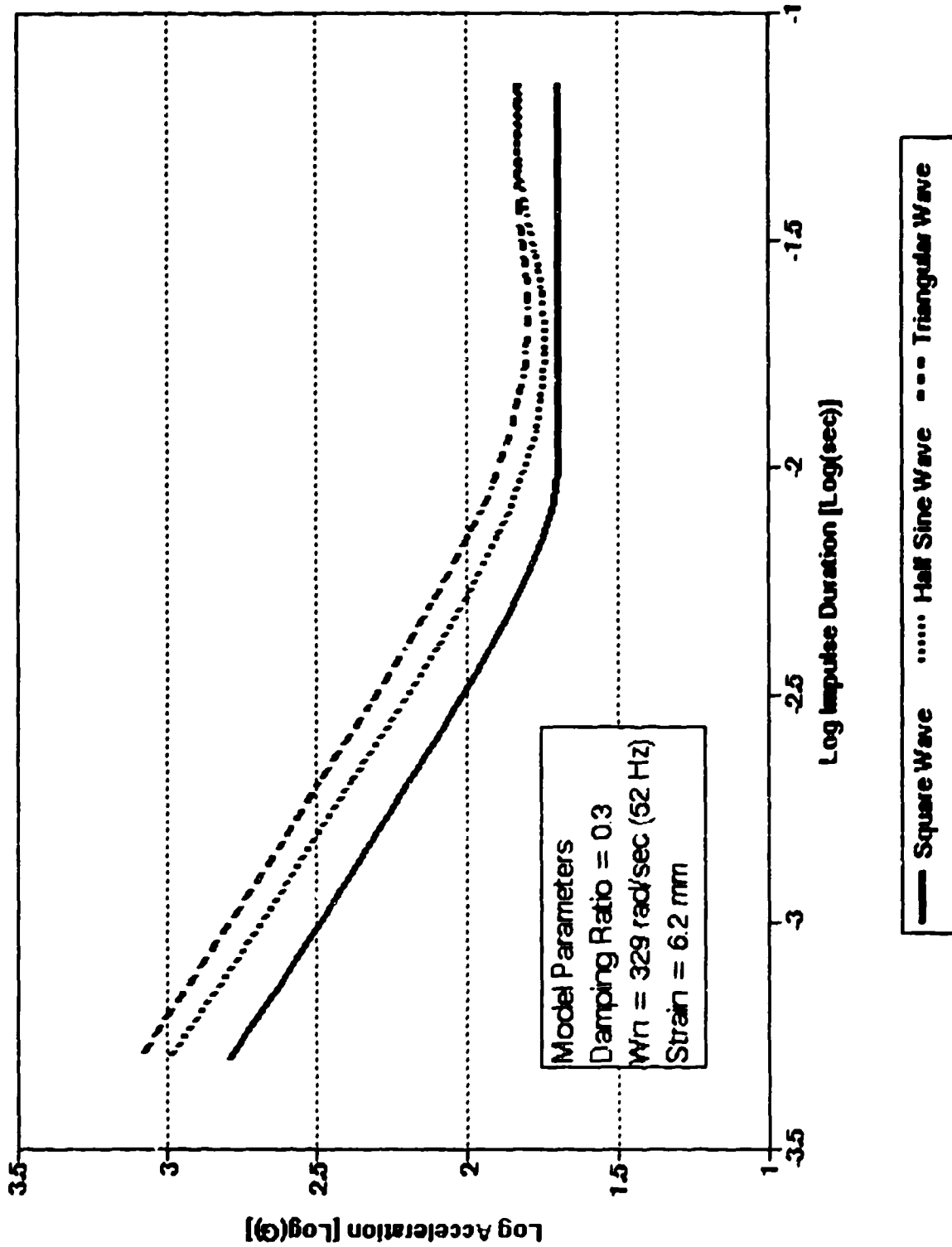

Figure 9.

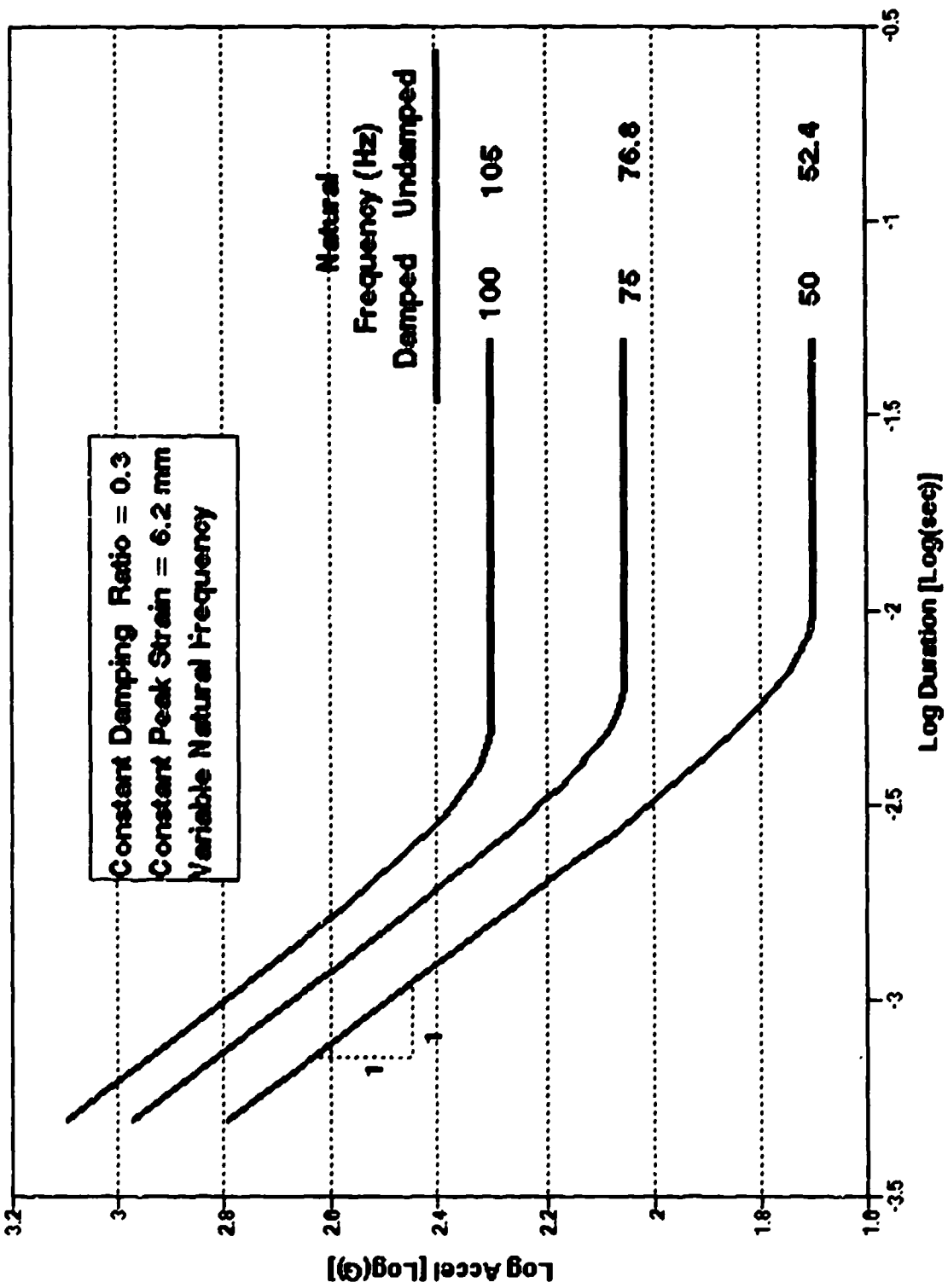

Figure 10a.

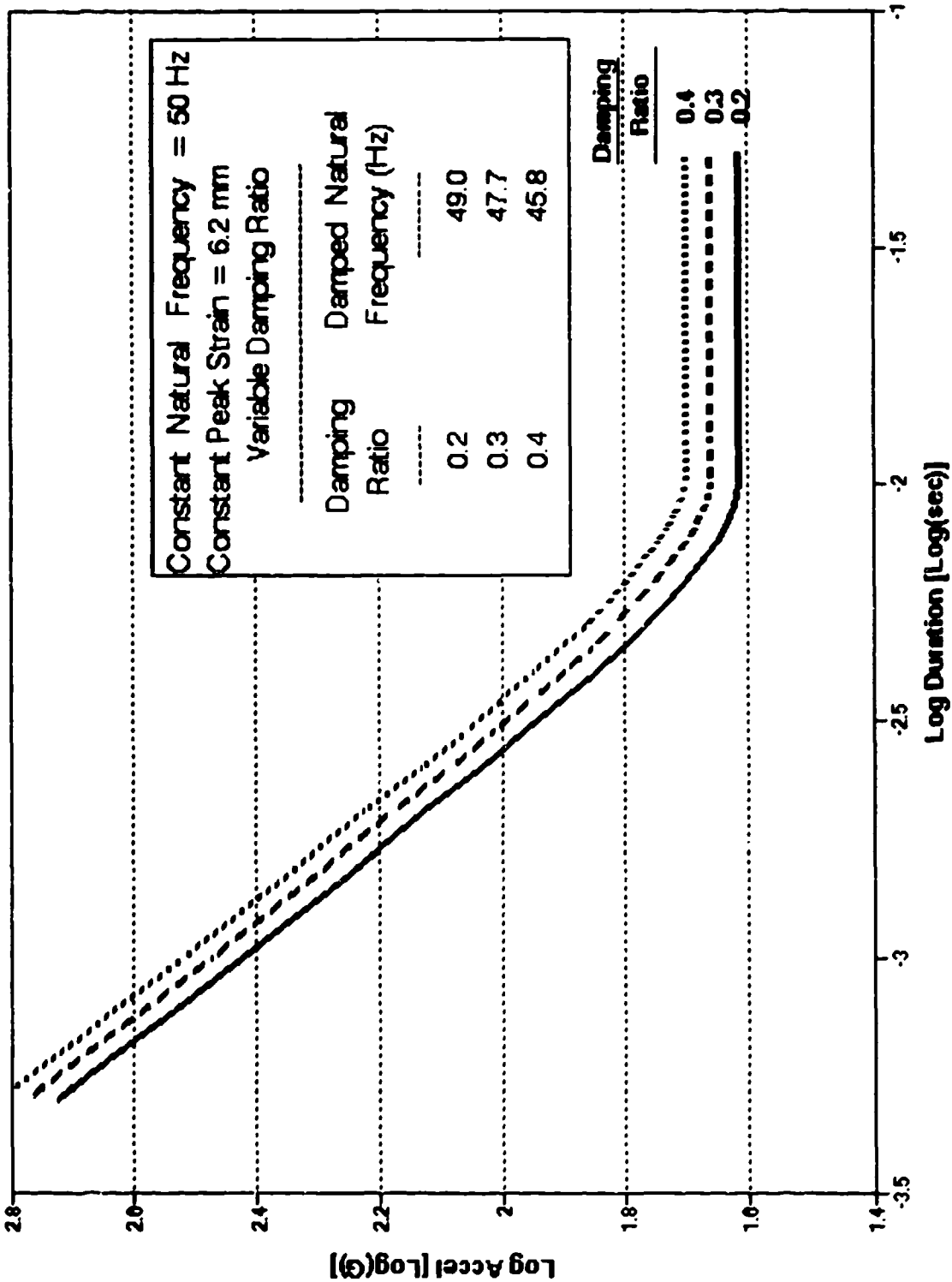

Figure 10b.

the damping ratio decreases the peak strain for a given input acceleration pulse. Therefore, increased peak acceleration is required to produce the same strain as the damping increases. The damping ratio also affects the crossover point through its effect of shifting the damped system's natural frequency to the right on the plot of $\log \Delta t$ vs \log peak acceleration.

As damping approaches critical damping, the damped natural frequency goes to zero. Therefore, for systems with effective resonant frequency sensitivities, the chosen damping ratio for the model needs to be substantially less than that for critical damping. A caution needs to be stated here, since it may be tempting to think of the spring in the model as being responsible for the long-term behavior of the system and the damper as the component responsible for the velocity dependence for short pulse durations. This is clearly not so, since an entirely undamped system, consisting only of a mass and spring, will exhibit the behavior of Figure 4 in response to square wave pulses of various durations. This is because the response of Figure 4 defines the maximum deflection of the system.

Therefore, the choice of the ratio between spring constant and mass value is determined primarily by the observed natural frequency for the system. Data having the general shape shown in the curves of Figure 10 could, therefore, be fit satisfactorily by a variety of candidate system models with various damping ratios. The quandary is basically to select the appropriate damping ratio which fundamentally determines the observed behavior of the system near the cross-over point. Brinkley has demonstrated an approach to approximation of an appropriate damping ratio based upon observed acceleration amplification in human impact tests.⁸⁰ A similar approach using head injury observations might be formulated for determining an appropriate damping coefficient for the head injury model. For the present, considerations based upon experimental test results and human vibration response provides an intuitive basis to select a damping coefficient which produces some overshoot and rebound for a step input of acceleration. For this reason, damping coefficients in the range from 0.2 to 0.4 are selected for preliminary curve fitting.

Figures 11 through 16 show curve fits defined to be below the preponderance of demonstrated injury levels in various tests using long duration pulse sensitivities at different levels to demonstrate the approach. Figure 11 is data from Kikuchi and co-workers demonstrating concussion response to lateral head impacts. In this example a square wave representation is used for illustration on the basis of average acceleration despite the non-square wave characteristics of the experimental driving function. Figure 12 demonstrates another fit to data from Kikuchi for lateral impacts involving more significant brain pathology. Both of the Kikuchi curves represent data scaled to humans from primate impact tests. Figures 13 through 15 represent data from Ono⁸¹ in which cadaver head drops were accomplished with skull fracture as an endpoint. Figure 15 represents rotational acceleration extrapolated to human heads from primate data by dimensional analysis. There were some fractures and cerebral contusions found postmortem.

Figure 16 represents rotational data from Thibault showing concussive injury data in response to angular acceleration. These data were also extrapolated by dimensional analysis to humans

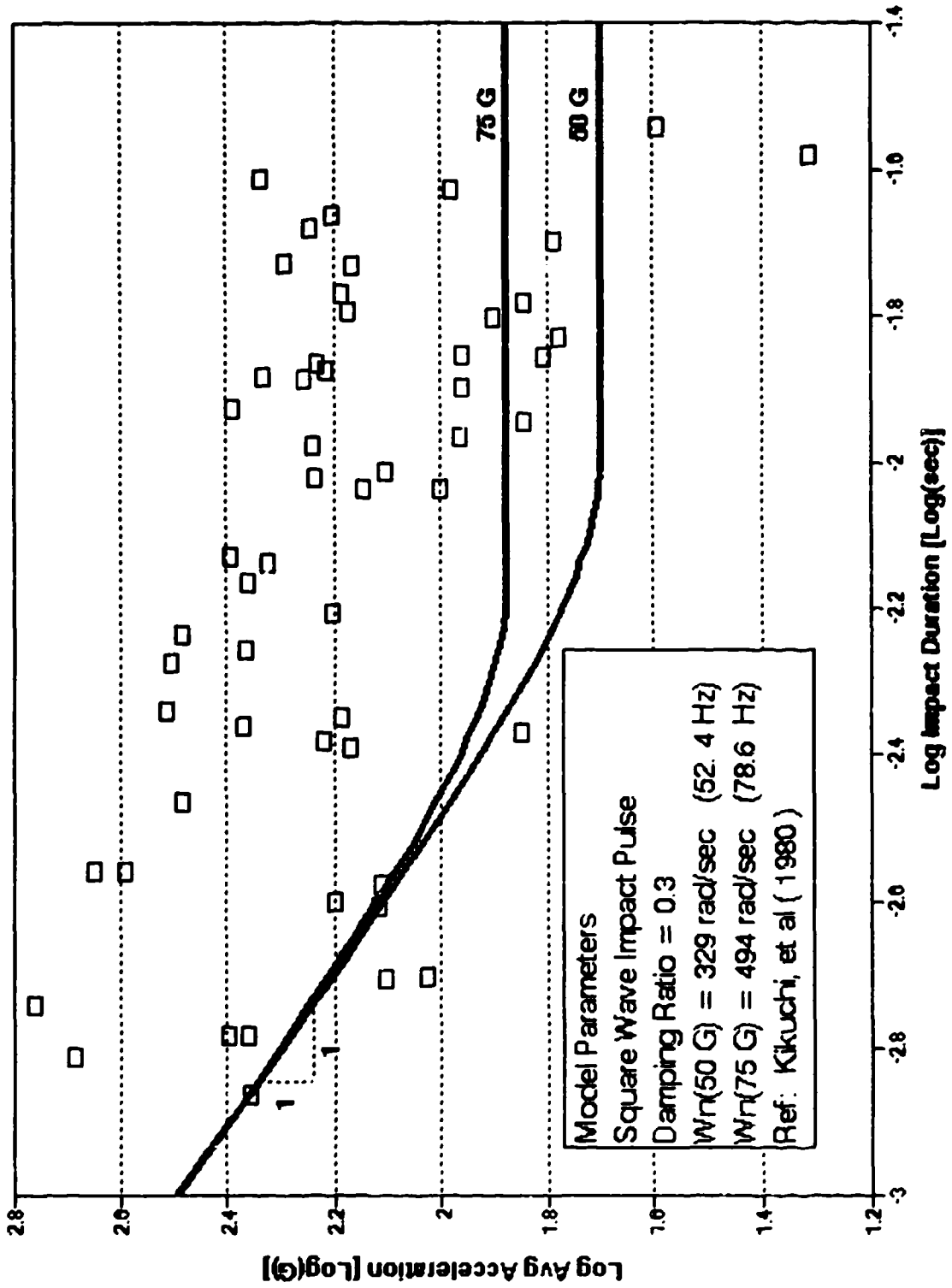

Figure 11.

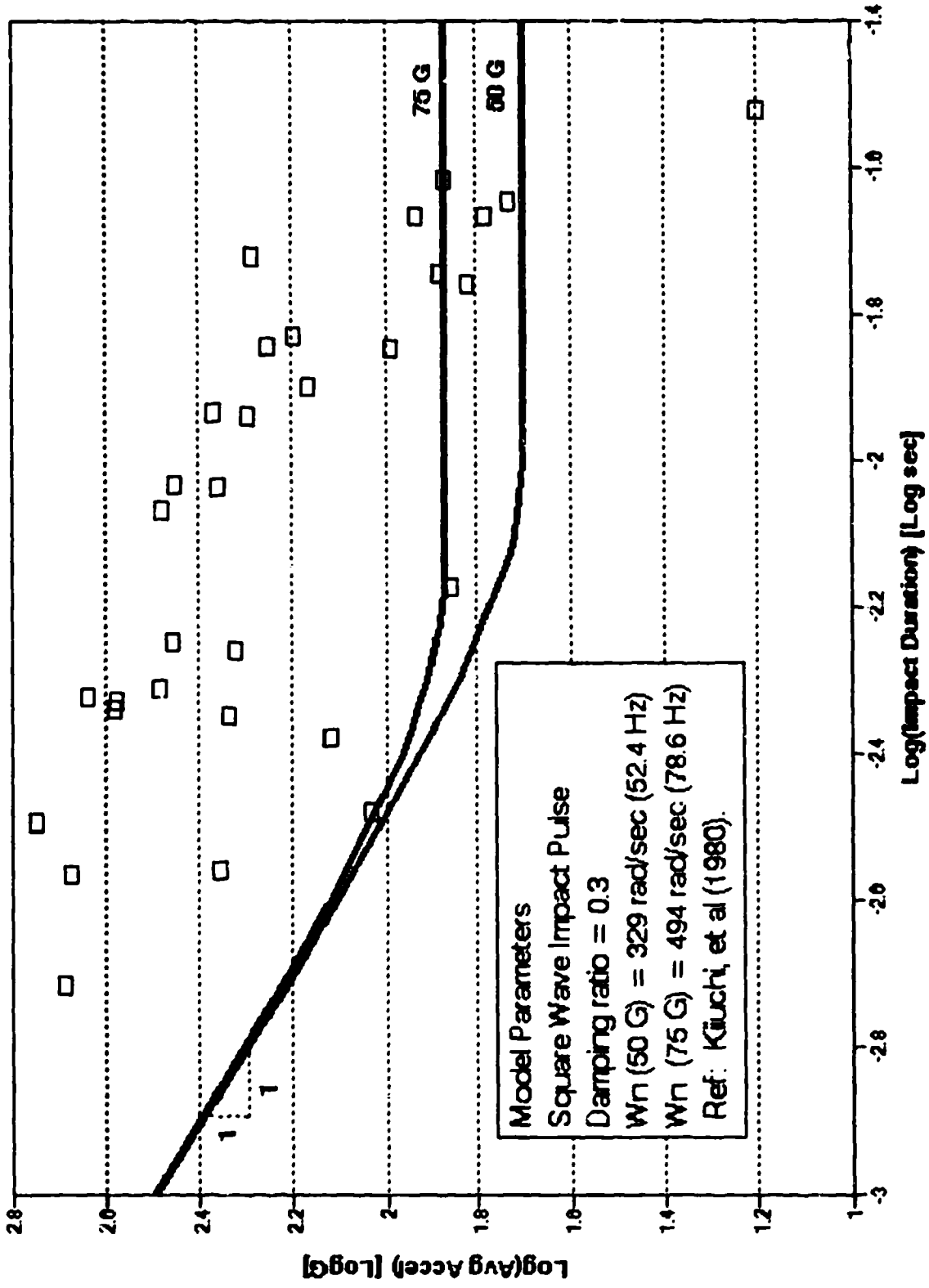

Figure 12.

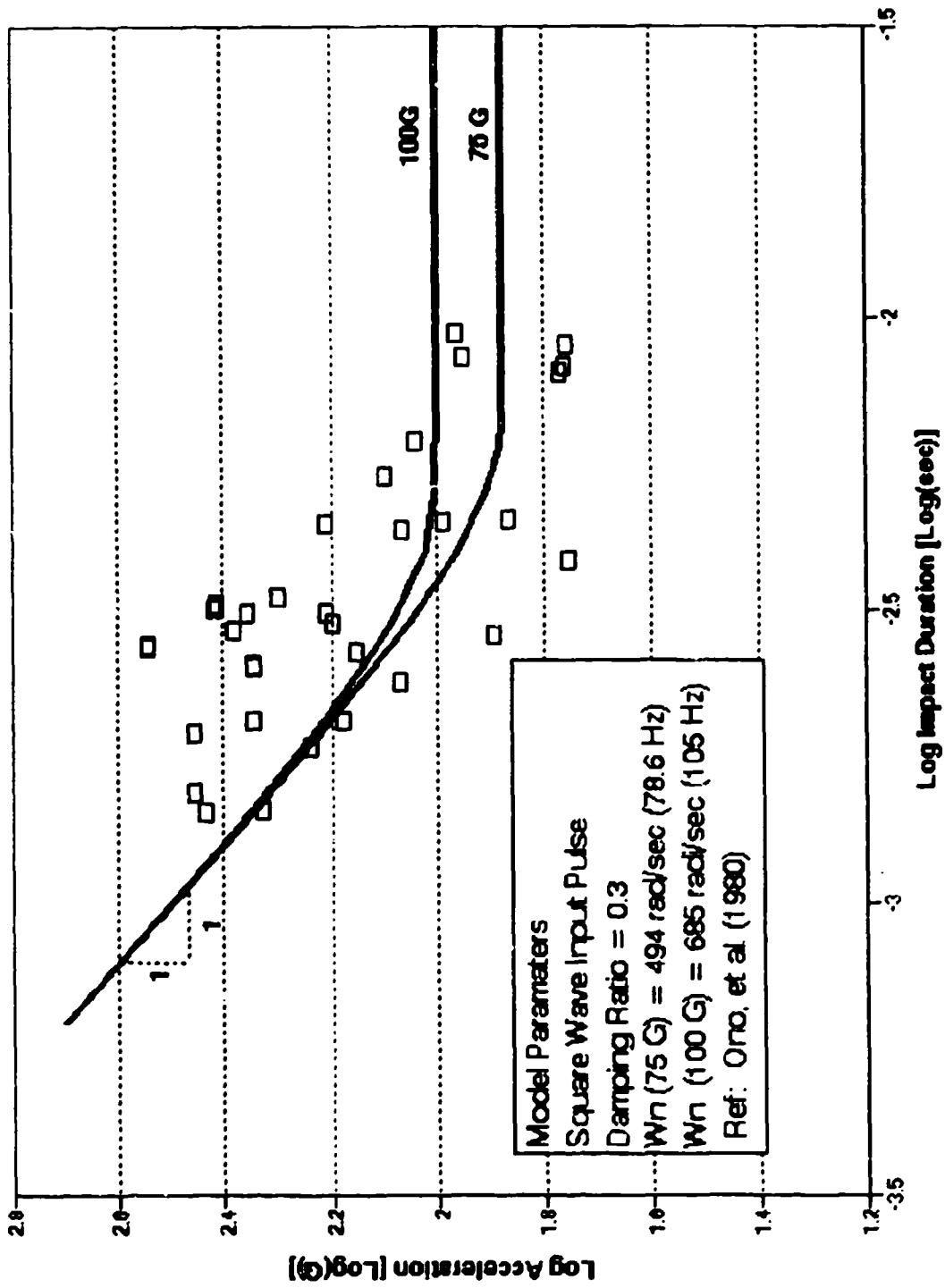

Figure 13.

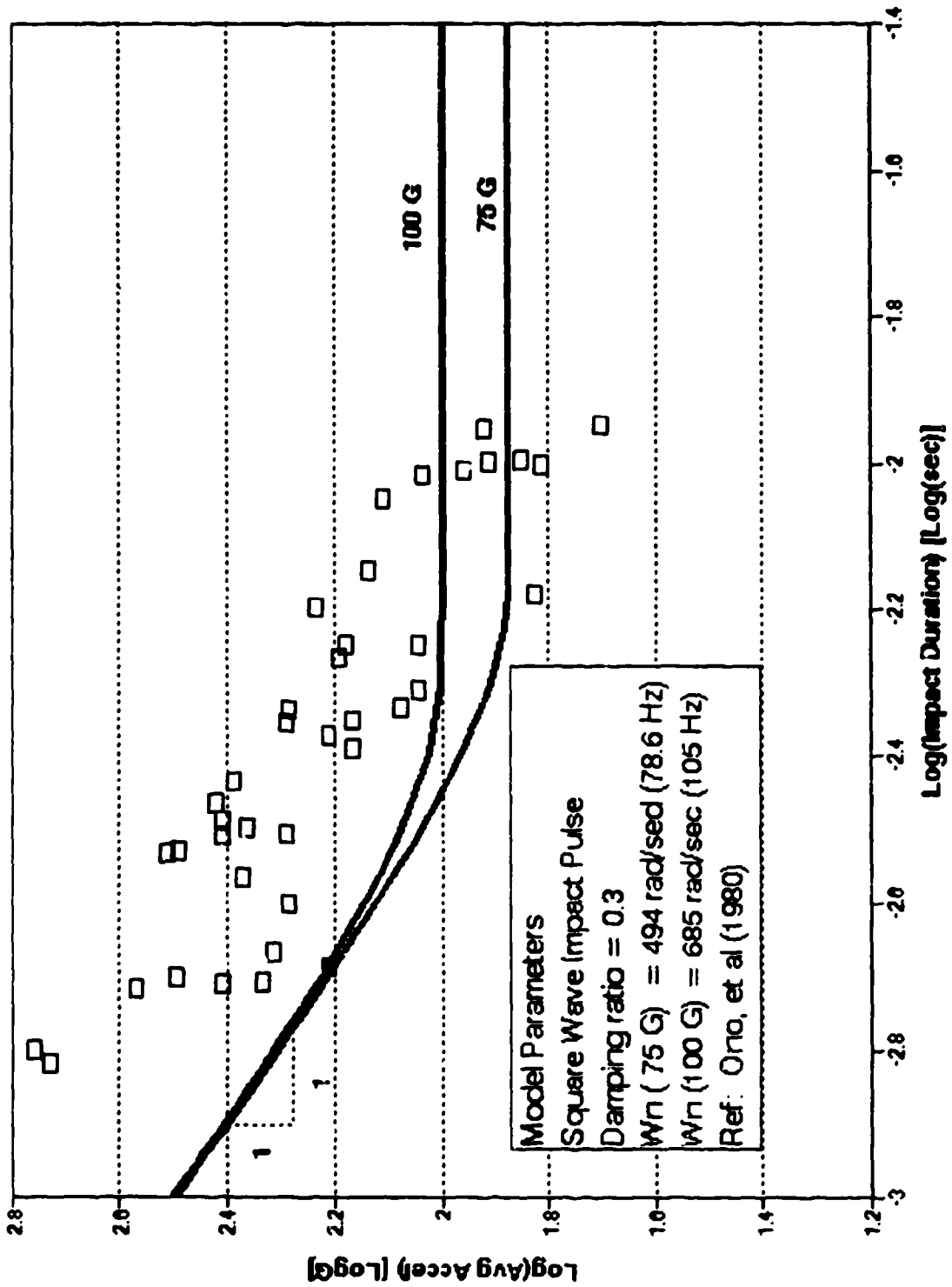

Figure 14.

from primate exposures. These values are considered more relevant to a functional disturbance than are the curves in Figure 15. It is noted that these data may be reasonably compared to Ommaya's maximum criterion of 4,500 rad/sec².

Clearly, the curve fits to the data could be adjusted closer to the injury data points. However, the form of the short duration acceleration responses appears to be well represented by the constant strain square wave curves for a viscoelastic system. The precise modeling response should be attained by applying the exact acceleration time history function to the model and defining constant strain criteria therefrom. The initial curve demonstrations are, therefore, included simply to illustrate the suitable form of the criterion and not to define the values for the parameters at this stage.

Before proceeding to the consideration of neck response, some final comments will be offered with regard to Equation (7). The form of Equation (7) effectively assumes that translational and rotational accelerations have independent effects when applied to the head, as well as an interacting effect represented by the cross product. A first level approach to a criterion utilizing translational and rotational models separately may not allow the assessment of possible interactions. An example of the implementation of Equation (7) is shown in Figure 17 in which artificially generated curves for X- and Y-axis translational acceleration pulses are applied during a pitch axis pulse using varying damping ratios and durations. The magnitude of the translational strain vector is represented on the plot as well as the magnitude of the cross product of the translational strain vector and the rotational strain vector as a function of time.

Figure 18 depicts a comparison of a constant strain curve for a range of square wave pulse durations with the comparable values for a constant Head Injury Criterion computed at these levels. It is clear that the current Head Injury Criterion (HIC) does not have the required behavior for variations in pulse duration as exhibited in a constant strain approach. The comparison shown in Figure 19 demonstrates the differences over these frequency ranges between different waveforms for HIC.

The question may arise as to why the single mass viscoelastic system is chosen for the model rather than a two-mass model along the lines of the Maximum Strain Criterion. The answer lies principally in the objective of the model. The Mean Strain Criterion approach provides a more effective representation of the physical behavior of the head, but the model remains an abstract representation using the lumped parameter approach. The BRC approach, by contrast, is simply an attempt to model the phenomenon of injury occurrence rather than any anatomical behavior of the head itself. As such, the injury data appears to be adequately accommodated by a simple, single-mass, lumped parameter viscoelastic system. The additional complexity of a second mass is not required in order to fit the data and provides no conceptual increase in sophistication.

While the precise definition of the required head injury criterion has not been established, a logical approach to the form of its general definition has been achieved. Sufficient data exists to potentially validate the approach through a combination of mathematical constant strain assessments using available human volunteer data for tolerable levels, human accident data, and scaled animal data for injury thresholds.

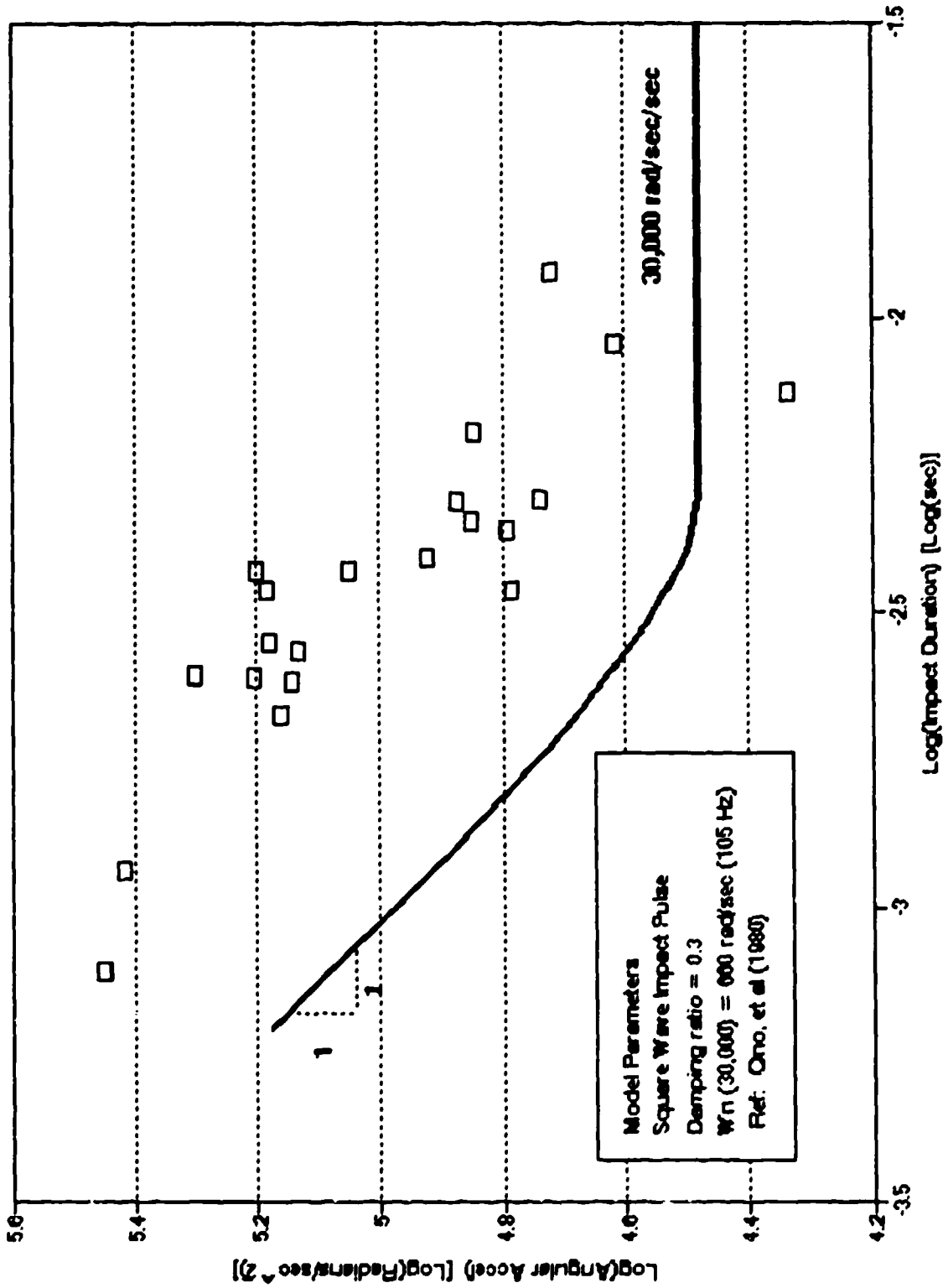

Figure 15.

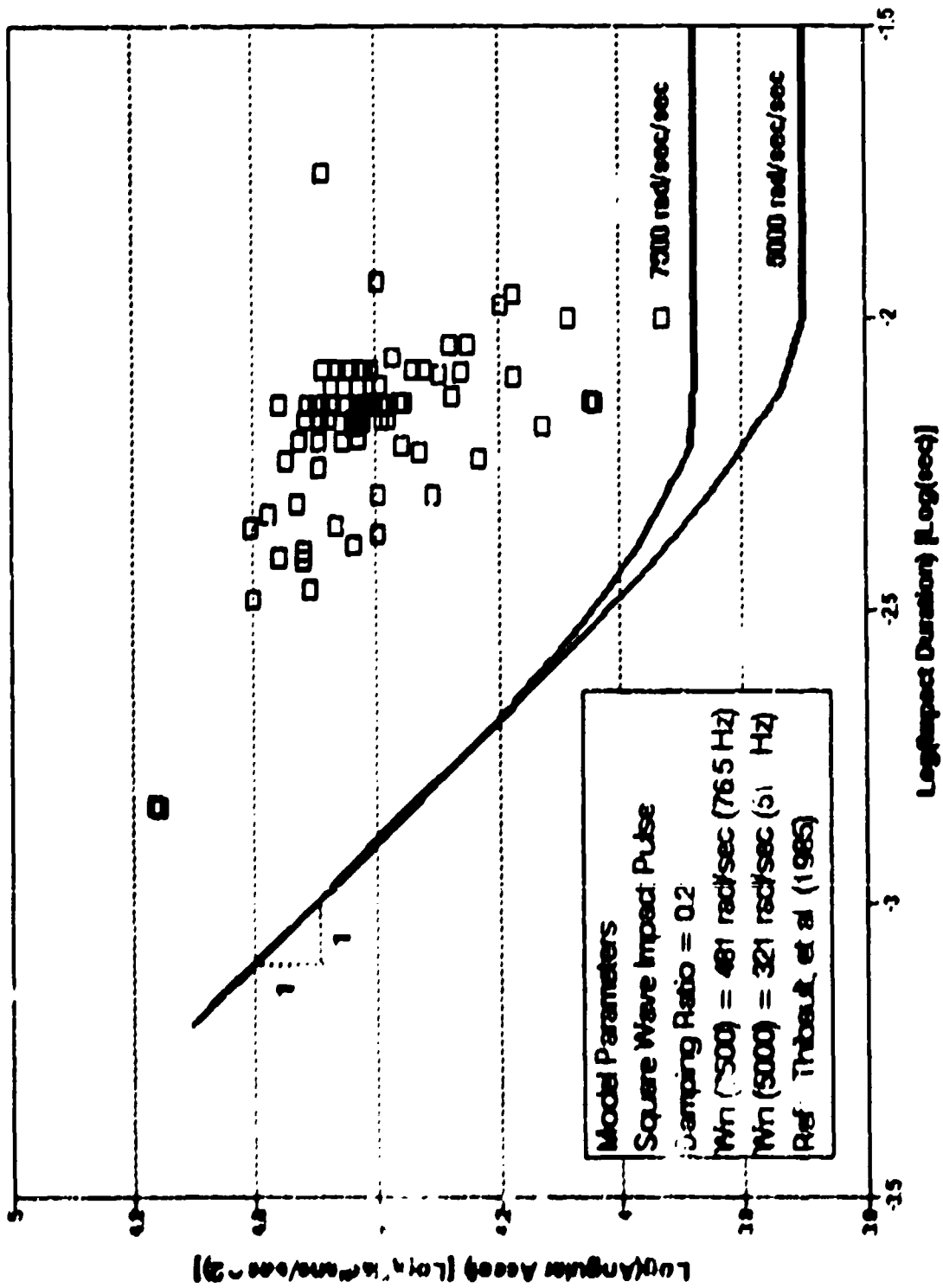

Figure 10

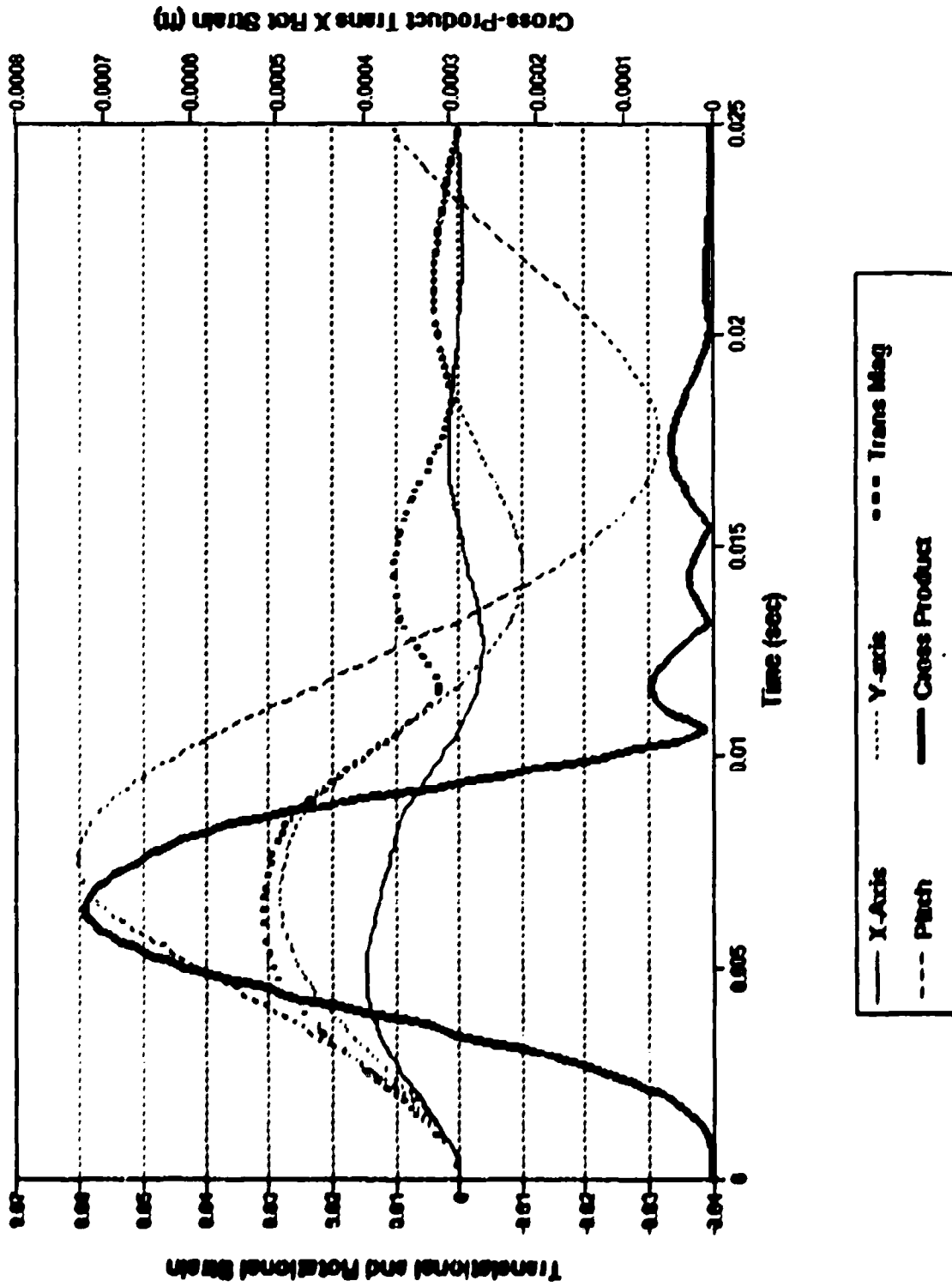

Figure 17.

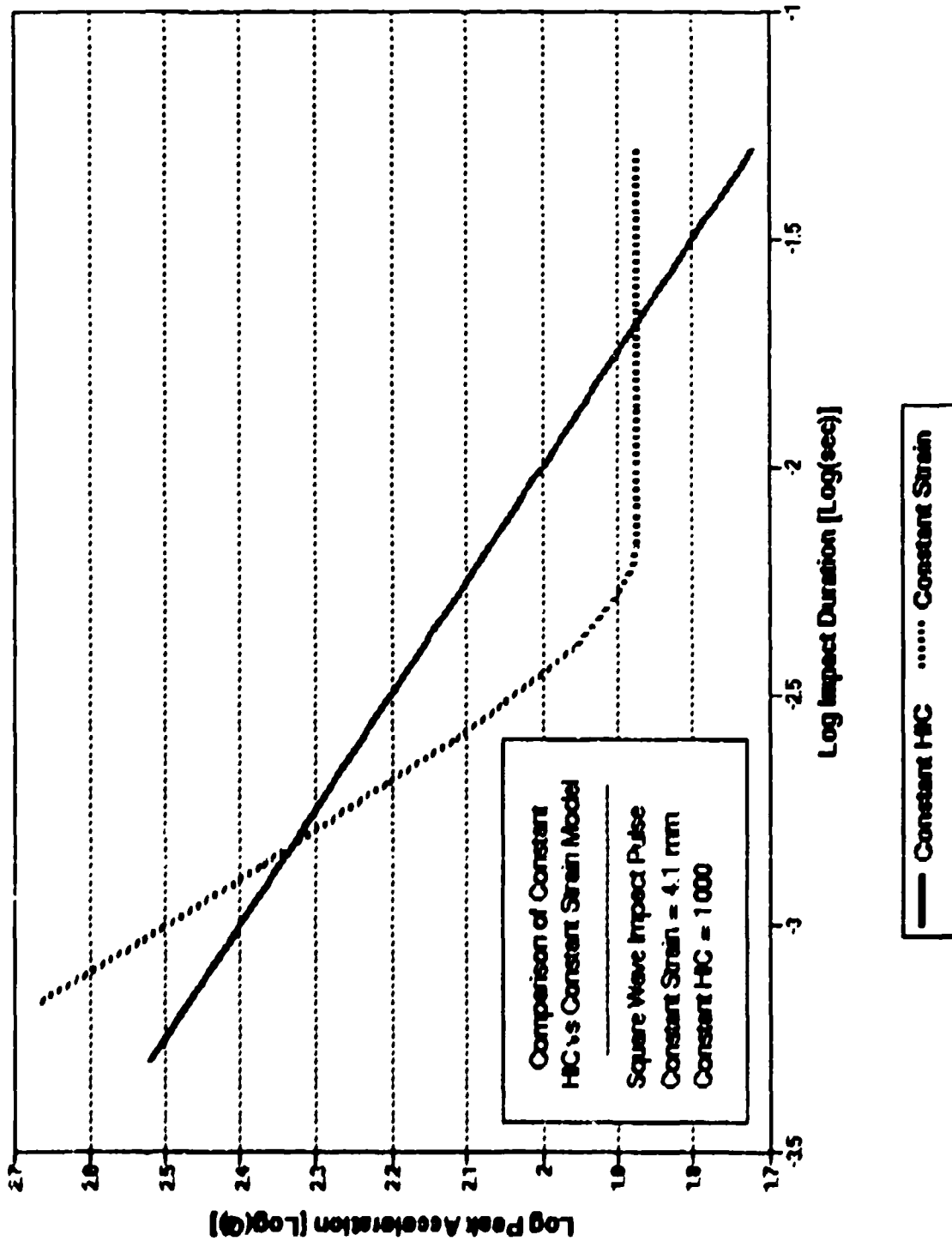

Figure 18.

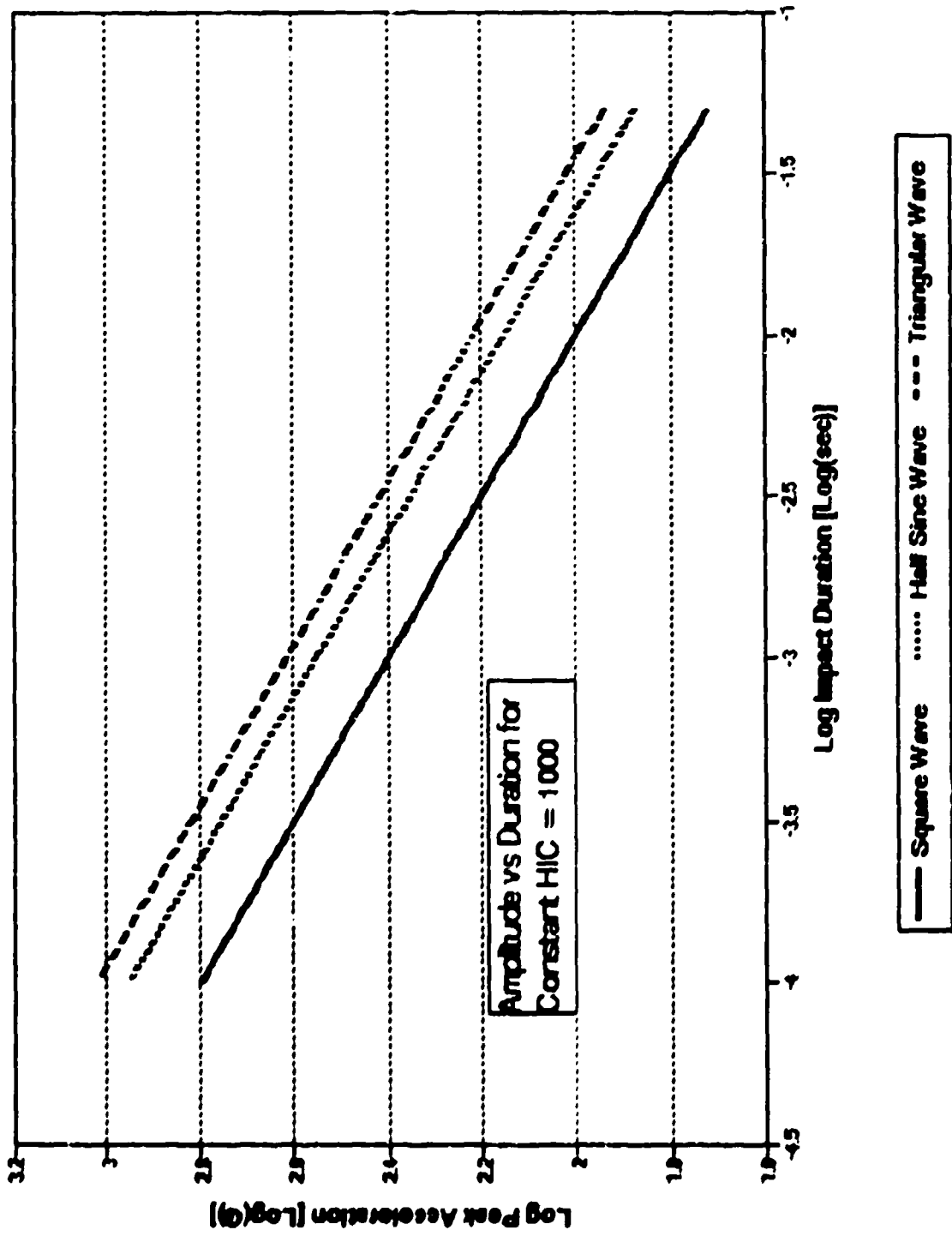

Figure 19

NECK

Literature Review

Numerous studies have investigated cervical fractures and dislocations. A review of these studies is presented, first looking at the studies that tested whole cadavers, three studies that correlated Hybrid III neck loads with injury producing impacts, and then studies that produced fractures and dislocations in isolated cervical specimens.

Cadaver Studies

Most of the early studies on compression loads to the neck were related to improved helmet design aimed at reducing cervical injuries in sports. These early studies loaded the crown of the head in order to create injury-producing neck loads. Thus, the actual load on the neck is the crown load minus the force required to accelerate the head.

Culver, et al¹² were interested in determining if basilar skull fractures occurred with axial loadings of the head and placed their supine cadavers in a position so that the neck was aligned with the 9.9 Kg padded impactor. Because the normal lordotic curvature of the cervical spine was maintained, the neck went into extension on impact, and the spinous processes fractured as well as the bodies of some vertebrae. The threshold fracture force was 1281 lb. The mean peak crown load for the eight impacts was 1623 ± 301 lb (n=8).

Hodgson, et al¹³ performed crown impacts on the heads of cadavers that were wearing protective helmets. A spring-loaded tackling block with a 121 lb mass was used as the impactor. Load cells were placed at three levels of the cervical spine. Results indicated that crown loading did not correlate well with cervical spine strains; the local strain depended on the distribution of the impact force and the position of the neck relative to the head. The "gripping action" of the padded tackling block restricted rotation of the head about the occipital condyles, and greatly increased the chance of serious neck injury.

Nusholtz, et al¹⁴ investigated the effect of the orientation of the head/neck/torso system in the crown impacts of 12 cadavers. By placing the cadavers in different positions relative to a 56 Kg impactor they were able to produce flexion/compression and extension/compression fractures, as well as combination fractures, which had flexion/compression injuries in the upper thoracic vertebrae and extension/compression injuries in the upper cervical spine. The mean peak force in the ten tests where fractures were produced was 1283.7 ± 714.2 lb (n=10). Nusholtz, et al concluded that the pre-impact orientation of the cervical and thoracic spine is a critical factor in determining the type of injury produced.

Alem, et al¹⁵ impacted fourteen cadaver heads in the superior-inferior direction with a 10 Kg impactor in order to produce basilar skull fractures or neck injuries. The heads and necks of the cadavers were placed in various positions relative to the trajectory of the impactor. The padding on the impactor was also varied. Four of the impacts produced no injuries and two

produced basilar skull fractures. In the eight impacts that produced cervical injury, the mean peak crown force was 1354 ± 686 lb ($n=8$). The impulse (force x duration) was found to be the best indicator of injury level, although no quantitative measure of injury level was given.

Hybrid III Studies

Mertz, et al⁸⁶ developed a criterion for compression neck fractures by measuring compressive neck loads on a Hybrid III test dummy in the simulation of cervical accidents that occurred with a spring-loaded tackling block. In the simulations, the dummy was positioned so that the axis of the neck was aligned with the trajectory of the tackling block. Injury references for axial compressive loading were developed by propelling the tackling block into the head of the Hybrid III at 22.7 ft/sec. The duration of the axial neck loads measured in the Hybrid III were used to set an injury reference for football players. Another injury reference was set for the adult population using a slower impact speed of 16.6 ft/sec. Figure 20 shows a graphical representation of their time-dependent injury criterion for the adult population. Exceeding the criterion implies that major neck injury is likely, however, being below the criterion does not imply that major neck injury will not occur, especially if other neck loads are present.

Two years later, Nyquist, et al⁸⁷ correlated Hybrid III data to field injury data in order to establish injury assessment levels. Injury assessment values define levels of human response below which significant injury is unlikely. The field databasc included injury data from 98 Volvo frontal accidents that contained at least one occupant restrained with a three-point restraint system. Sled tests were performed with a Hybrid III ATD in order to recreate the forces in these accidents. During the sled tests, an upper neck load cell measured neck axial force, shear force (A-P direction) and the flexion-extension bending moment in a Hybrid III restrained with a three-point belt. The Hybrid III transducer outputs in sled tests performed at a fixed barrier equivalent velocity (BEV) were compared with the injury levels from field crashes at a similar BEV. The mean tolerable axial tensile force was found to be 740 lb.

Mertz⁸⁸ analyzed the data of Nyquist, et al and developed a time-dependent injury assessment criterion based on the durations of the loadings measured in the Hybrid III's neck during the sled accelerations. The injury assessment criteria for neck tension is shown in Figure 21.

Isolated Spine Studies

In this literature review a cervical spine specimen refers to an isolated spine segment that includes C1 through T1 and usually includes the complete skull or some portion of it. Impact studies on isolated cervical spine specimens probably provide the best method of determining the loads that produce bony failures in the neck, as the use of the specimens allows the load at which the neck fractures to be directly measured. Also, the pre-load position of the spine can be better controlled than if a complete cadaver is used. The specimens are usually from unembalmed cadavers that have been selected based on a review that precludes any known bone or spinal disease. The muscle and surrounding fat and soft tissue are removed, leaving the ligaments and bony structures intact. This technique may, however, alter the behavior of the

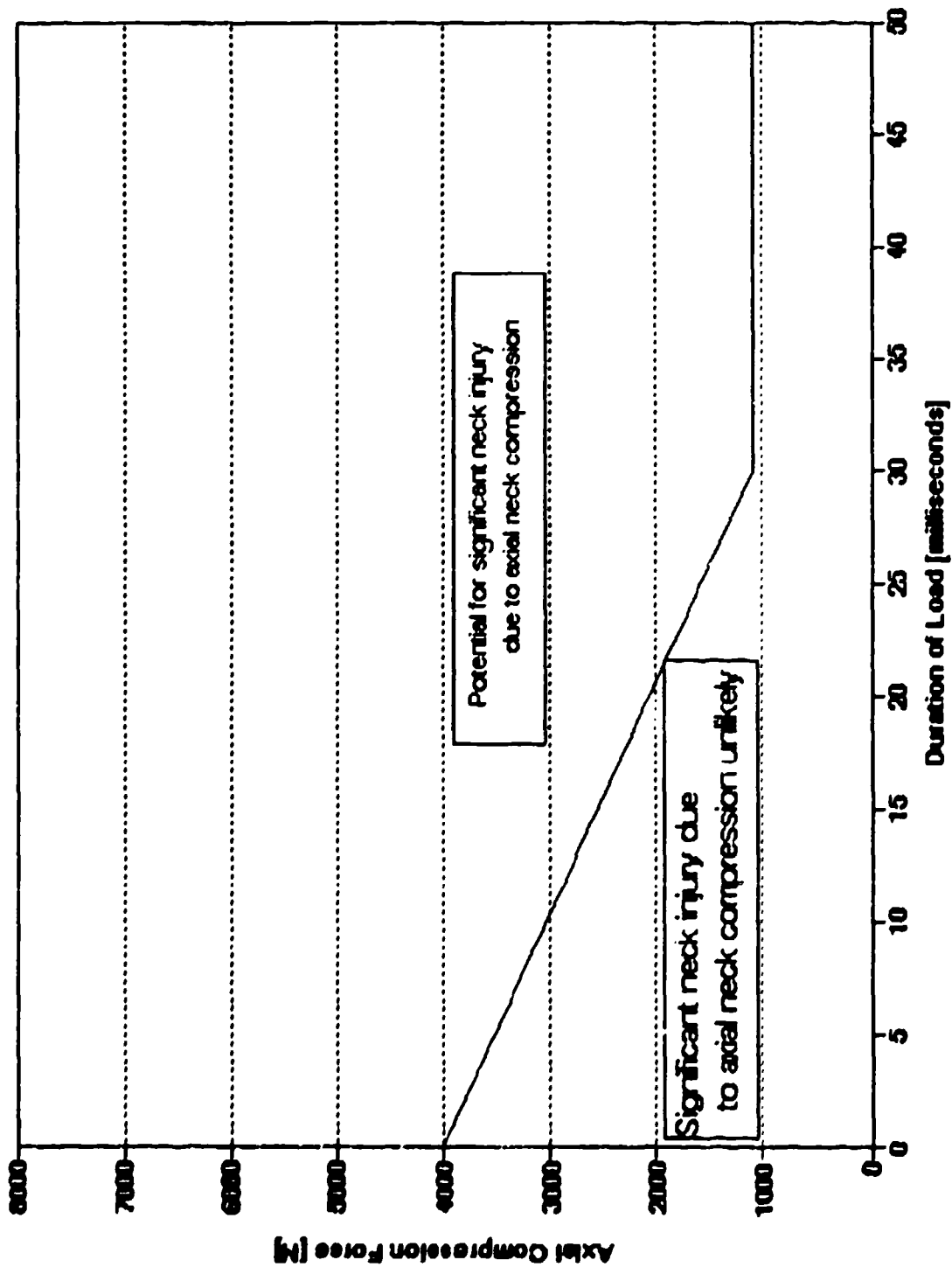

Figure 20. Injury criterion for compressive neck loads (from Mertz, et al)⁷⁹

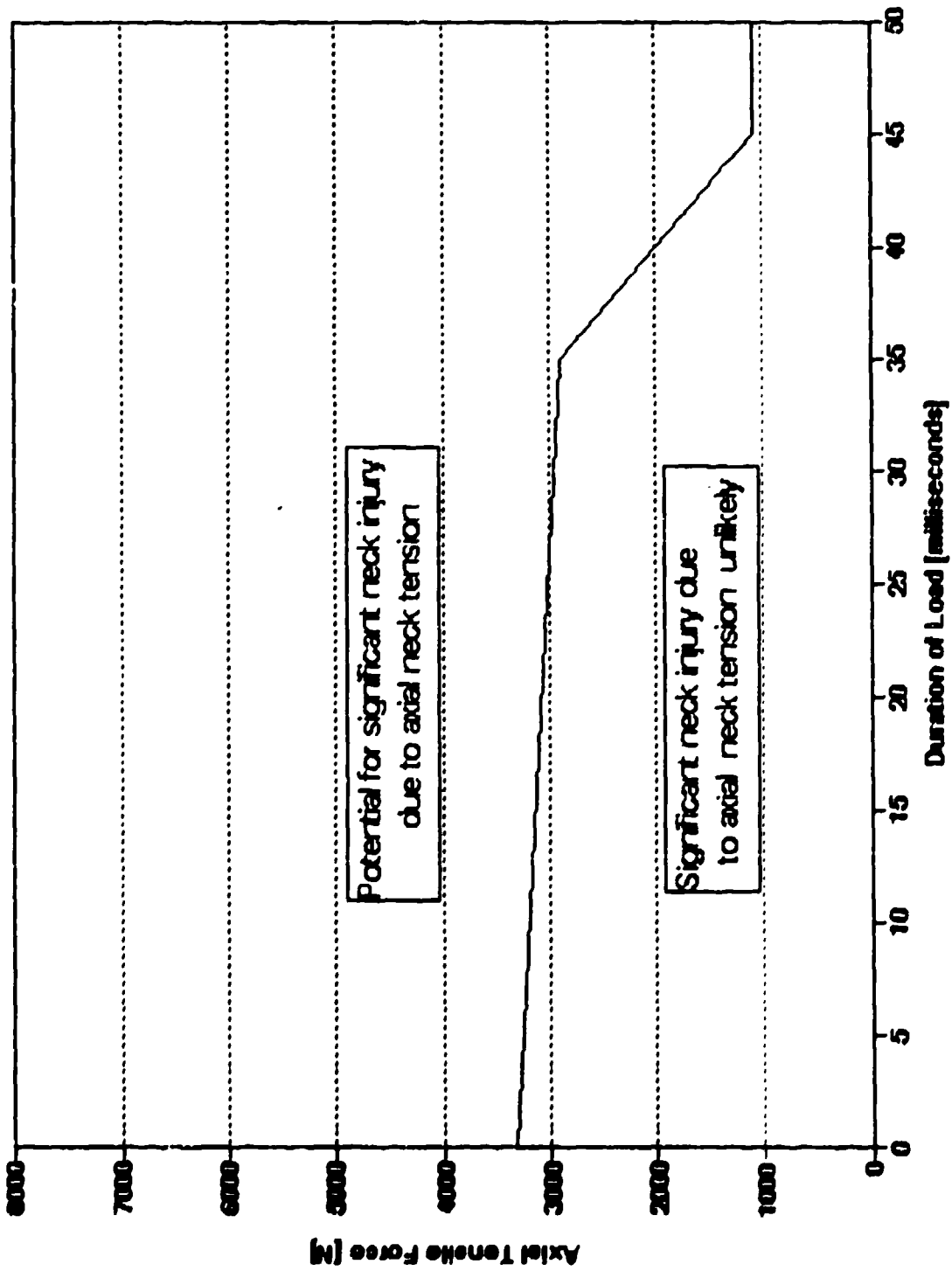

Figure 21. Injury assessment criterion for tensile neck loads (from Mertz).

denuded structure.

Roaf⁸⁹ was one of the first to investigate the reaction of the basic spinal unit (two vertebrae and the connecting disc) to applied loads. He found that cervical vertebral bodies fail at approximately 1400 lbs and cervical discs fail at 1600 lbs. He was unable to produce dislocation with hyperflexion only, and incorrectly assumed that axial rotation was the only input necessary to produce dislocations. He concluded that rotation forces produced dislocations and axial forces produced fractures.

Bauze and Ardran⁹⁰ attempted to define the injury mechanism and cervical spine orientation during accidents that caused bilateral locked facets. They submitted cadaver cervical spines to compression loads while constraining the superior end of the specimen (the head) in rotation but not in translation. The lower cervical spine was completely restrained by placing a steel pin through the spinal canal from the thoracic mount to the cervical level where the dislocation was desired. By compressing the specimen, they were able to produce bilateral dislocations, usually C5 moving anteriorly over C6, without fracturing vertebrae in six of fourteen specimens. During the compression the cervical spine took on a characteristic shape, the "ducking" shape, where the superior end of the specimen was in extension and the inferior end was in flexion (analogous to ducking your head to go under a low obstacle). The peak axial load measured in the six specimens that had bilateral locked facets was 325 lb.

McElhaney, et al⁹¹ studied the time-dependent responses of cervical spine specimens to dynamic compressive loading. They demonstrated that the neck's mechanical response can be preconditioned, i.e., there was a decrease in stiffness of an equilibrated specimen, one that has been unloaded for at least 24 hours, as it was cyclically deformed 0.7 cm at 20 Hz. After approximately 150 cycles, a steady state, or mechanically stabilized state, was reached. The change in stiffness was thought to be due to the osmotic state of the vertebral discs. A mechanically stabilized spine was found to have a stiffness that increased by 60% when the deformation rate was increased from 0.1 cm/sec to 64 cm/sec for deformations up to 0.5 cm.

The fracture patterns of the mechanically stabilized specimens were found to be extremely sensitive to the placement of the axial load relative to the axis of the specimen.⁹¹ Burst fractures were produced with straight or slightly flexed specimens. Eccentric loads applied up to 1 cm anteriorly produced anterior wedge fractures. Jefferson fractures were produced with straight or slightly extended specimens. Eccentric loads applied 1 cm posteriorly produced extension/compression fractures.

Maiman, et al⁹² produced flexion, compression, and pure axial loading in isolated cervical spines that were loaded with a hydraulic piston. Four of the specimens were placed in a 25° pre-flexed position and one was placed in a 25° pre-extended positions. The other five specimens were aligned with the piston. The mean peak load for the vertically positioned specimens was 907 ± 519 lb ($n=5$), for the four pre-flexed specimens the mean peak load was 418 ± 216 lb ($n=4$), and for the single pre-extended specimen the peak load was 150 lb. Of note were three cases of atlantoaxial dislocation, two occurring in the pre-flexed mode and the

other in the pre-extended mode. The mean peak load for the atlantoaxial dislocations was 231 ± 146 lb ($n=3$).

McElhaney, et al⁹³ measured flexural and axial bending stiffness in cervical spine specimens with a test fixture that could create two different end conditions. In one configuration the superior and inferior ends of the specimen were free to translate vertically and rotate in the sagittal plane. The specimens were loaded with an eccentric load. Constant velocity (quasi-static) failure of four specimens with this end condition produced dislocations with the primary failure mechanisms being disruption of the ligamentum flavum, interspinous ligament and the capsular ligaments. The average flexion angle change was 46° . The mean peak axial load was only 50 lbs, and the mean peak moment measured at the inferior end of the specimen was 66 in lb. In the second configuration the inferior end of the specimen was not allowed to rotate. Failures in this mode had mean peak axial loads of 430 lbs and mean peak moments of 6.2 ft lb. The mean angle at the time of maximum moment was 19° . The failure mechanisms were disruption of the posterior ligaments, as well as wedged vertebral bodies and discs.

Pintar, et al⁹⁴ studied the anatomical alteration of bony and soft tissue under failure loads. Seven fresh head/neck complexes were loaded to failure with a constant deformation rate of 2 mm/sec (quasi-static). The spines were set in a vertical orientation and loaded through the skull. Failure was defined as a drop in the force vs time trace. Failure loads had a mean value of 516 ± 160 lb ($n=7$), and a mean deformation of 2.5 ± 1.0 cm, which includes skull deformation as well as neck deformation. The specimens were frozen in the compressed state and sectioned in order to determine the anatomical alterations of the soft and hard tissues and the time the injury occurred. One specimen was considered to have failed in pure compression, two in flexion/compression and four in extension/compression.

Pintar, et al⁹⁵ did a temporal study of cervical fractures using six isolated cadaver spine/head specimens. The spines were positioned so that the natural lordosis was removed and the axis of the cervical spine was aligned with the trajectory of a padded impactor that struck the crown of the head at speeds ranging from 9.7 to 26.7 ft/sec. Each cervical specimen was tagged with reflective targets that were filmed at high speed. The neck loads were measured at the base of the specimen. The mean peak compression load was $788 \text{ lb} \pm 437 \text{ lb}$ ($n = 6$). The lowest peak force of 264 lb produced a wedge fracture, while a load of 820 lb produced a burst fracture. The burst fractures occurred over a period of 2ms, while the compression fracture had a period of approximately 4ms.

Recently Nightingale, et al⁹⁶ axially loaded cervical specimens with three different constraints on the superior end of the specimen: no-constraint (fore-aft translation and rotation in the sagittal plane), rotational constraint (fore-aft translation) and full constraint. The inferior end was allowed to translate along the vertical axis. This study sums up much of the previous work on the importance of the head/torso position at the time the neck is quasi-statically loaded. Table 5 summarizes the results of this study. In the no-constraint mode the neck was able to undergo flexion until chin contact would have transferred loads to the torso (if a chin and torso had been there). There were no injuries to the specimens in this mode. With rotational

constraint placed on the occipital condyle joints, axial loads produced bilateral locked facets in all six specimens with a mean peak load of 387 ± 277 lb (n=6). Based on the schematics shown in their paper, the cervical spine took on the ducking shape described by Bauze and Ardran;⁹⁰ the superior end was in extension, while the inferior end was in flexion. A six-axis load cell measured moments at the inferior end of the specimen, but moment data were reported for only one specimen. This specimen had a peak flexion moment in the sagittal plane of 7.4 ft lb, which is similar to the flexion moment measured by McElhaney, et al.⁹³ When the head was completely constrained, axial loads produced burst and wedge fractures in all six specimens; and the mean peak fracture load was 1081 ± 289 lb. Moments were reported to be negligible for these fractures in this constraint mode. The mean deformation at the time of fracture was 1.4 ± 0.4 cm. The good repeatability in this study, both in terms of injury type and magnitude of loads, is probably due to the rigorous control of the ends of the cervical specimens in this test setup.

TABLE 5 - SUMMARY OF NIGHTINGALE, ET AL DATA⁹²

CONSTRAINT MODE	MEAN PEAK AXIAL LOAD (LB)	INJURIES
UNCONSTRAINED	64	None
ROTATION CONSTRAINT	387	Bilateral Locked Facets
FULL CONSTRAINT	1081	Compression Fractures

TABLE 6 - SUMMARY OF CERVICAL SPECIMEN FAILURE TESTS

INJURY MODE	DEFORMATION VELOCITY (CM/SEC)	MEAN PEAK AXIAL LOAD (LB)	STUDY
ATLANTO-AXIAL DEREGULATION	0.25-152	231 ± 146 ¹ (n=3)	Maiman, et al ⁹²
DEREGULATION BILATERAL LOCKED FACETS	not known	325 ² (n=6)	Bauze & Ardran ⁹⁰
	quasi-static	429 ± 126 (n=2)	McElhaney, et al ⁹³
	2	387 ± 126 (n=6)	Nightingale, et al ⁹⁶
C1/C2 FRACTURES, OCCIPITAL FRACTURES	64	1011 ± 173 (n=4)	McElhaney, et al ⁹¹
	23	339 (n=1)	Maiman, et al ⁹²
	0.2	347 ± 57 (n=2)	Pintar, et al ⁹⁴
JEFFERSON FRACTURES	64	665 ± 315 (n=4)	McElhaney, et al ⁹¹
EXTENSION/COMPRESSION	64	434 (n=1)	McElhaney, et al ⁹¹
	82-130	1332 ± 481 (n=2)	Maiman, et al ⁹²
	0.2	514 (n=1)	Pintar, et al ⁹⁴
FLEXION/COMPRESSION	64	1165 ± 270 (n=7)	McElhaney, et al ⁹¹
	112-120	765 ± 348 (n=2)	Maiman, et al ⁹²
	25-122	547 ± 180 ³ (n=2)	Maiman, et al ⁹²
	0.2	602 ± 145 (n=4)	Pintar, et al ⁹⁴
	295-813	789 ± 437 (n=6)	Pintar, et al ⁹⁵
	1	1081 ± 289 (n=6)	Nightingale, et al ⁹⁶

Table 6 summarizes the deformation velocities, peak forces and injury modes for the studies that loaded cervical spine specimens in the axial direction. The longitudinal axis of each specimen was aligned with the applied compression force except as footnoted. In many cases there were multiple damage sites in the specimens and the placement of a test's results in a certain injury

¹ Specimens were pre-flexed or pre-extended 25° prior to loading.
² Maximum peak load for all six tests.
³ Specimens were pre-flexed 25° prior to loading

category is based on the author's description of the damage to the failed specimen. The fractures of C1 and C2 are distinguished from fractures to the lower cervical vertebrae, C3 through C7. Fractures to the lower cervical vertebrae are broadly covered under extension/compression and flexion/compression injuries, a category that includes all specimens that received anterior wedge or burst fractures.

These data indicate that the neck acts as a beam with varying stiffness. When the neck is pre-flexed or pre-extended at the time that an axial load is applied, failure occurs at relatively low forces. Atlantoaxial dislocations can occur at relatively low axial forces of approximately 250 lb if the neck is hyperextended or hyperflexed at the time the load is applied. If the head is not allowed to rotate when the lower neck is placed in flexion, an axial load of approximately 350 lbs. can produce bilateral locked facets.

The mean peak fracture loads measured in the studies that produced flexion/compression and extension/compression injuries show a large amount of scatter. The mean fracture force would be expected to show some dependence on the deformation velocity, since most biological materials exhibit viscoelastic properties that allow them to increase their load carrying capacities as the duration of the load decreases. Surprisingly, these data presented in Table 6 do not support this viscoelastic behavior. For example, specimens compressed at 1 cm/sec had a mean fracture of 1081 lb in one study,⁹⁶ while those compressed at constant speeds ranging from 295-813 cm/sec had a mean fracture force of 789 lb in another study.⁹⁵

Some of the scatter in the fracture forces could be due to differences in the specimens, but the most probable explanation appears to be the method used to restrain the superior end of the specimen. Most specimens included at least the base of the skull, while some retained the entire skull. When the test mount for the superior end of the specimen was closely coupled with the occipital condyle joints, the fracture loads were high.^{90,96} In these studies the attachment plate was attached to the base of the skull, directly on the foramen magnum and over the occipital condyle joints. When the compression load was applied directly to the top of the skull with a flat plate,^{92,94,95} or a plastic filled skull with the piston inserted into the plastic,⁹⁴ or a plate placed on a horizontal plane of the skull,⁹² the load was applied away from the occipital condyle joints and the fracture loads were low.

The influence of rigid support is evident within a study as well. In the study by Maiman, et al,⁹² all but one of the specimens (#520) retained the entire skull or at least a significant portion of the base. The superior end of this specimen, which was from a 64-year-old subject, was intact only up to C1, and it was supported at C1 for the compression tests. This specimen had a fracture force of 1672 lb, over double the mean value of the other specimens that were loaded through the skull, 715 ± 338 lb (n=4). In this case elimination of the occipital condyle joints from the specimen appears to have made it significantly stiffer than the other specimens.

Close coupling of the load application to the occipital condyle joints probably reduces the rotation of the skull about these joints. With minimal rotation, both load-bearing paths of the cervical spine, the vertebral discs and the posterior elements can be loaded, and the fracture

force tends to be high. When the specimen is loaded through the skull, any eccentricities, or deviations, of the load path from the center of the spine are magnified. Once rotation occurs, one set of load-bearing elements will be preferentially loaded, and the greater the rotation, the greater the preferential loading. In this case, the force at the time of fracture is a combination of the fracture force of the load-bearing element that received the load and any load received by other load-bearing elements.

The slight eccentricity in the applied load, which leads to a decrease in the axial load required to produce a fracture, also leads to an increase in the moment in the sagittal plane. Pintar, et al⁹⁴ measured a mean flexion moment of 61.6 ft lb in six of their specimens and an extension moment of 74 ft lb in the other specimen tested and Pintar, et al⁹⁵ measured a mean flexion moment of 82 ft lb. On the other hand, Nightingale, et al⁹⁶ reported negligible flexion moments during the fracture of their fully constrained specimens. Based on this assessment, an interpretation of the flexion/compression fracture data would be that the data with negligible moments^{91,96} represents true axial loading where both load-bearing structures are used, and that the data from tests where large moments are developed^{94,95} represents slightly flexed specimens where the vertebral column is loaded preferentially over the posterior elements.

Proposed Criterion

The principal aim of the literature review was to obtain information that could be used to develop injury criteria for compression fractures and dislocations. The simplest form of an injury criterion provides a threshold number for the application of a quasi-static load, above which injury is produced and below which no injury occurs. The approach used here assumes that this threshold number represents a 50% probability line, where half the people exposed to the force would receive an injury and the other half would not. Such a criterion is based on mean values from the experimental injury data. In using this type of criterion one simply looks at the transducer output for the occurrence of a force or moment above the threshold value.

Compression fractures have been demonstrated in experimental situations with the cervical spine/head system aligned with the direction of the compression force. There appear to be two modes: one where the compression load is aligned with the axis of the spine, and the other where there is some slight eccentricity created in the test setup. The threshold value axial loading is based on the Nightingale, et al⁹⁴ data and the threshold value for compression fractures due to the axial loading with eccentricity is based on the Pintar, et al⁹⁶ data. Both of the data sets represent quasi-static compressions. Based on the limited data available, this threshold value appears to be applicable both for flexion and extension moments.

Compression Axial Loading — 1080 lb, minimal moment in the sagittal plane.

Compression Axial Loading with Eccentricity — 600 lb, 70 ft lb moment in the sagittal plane.

There is limited information on cervical tension injuries. Locked facets are clinically reduced using traction forces up to 150 lbs, but the usual reductions are performed using a tension force

between 50-100 lbs.⁹⁷ Mertz and Patrick measured noninjurious tensile levels of 250 lbs in human subjects.⁹⁸ Due to the lack of information on a single injury value, the 250 lb appears to be the best criteria, albeit very conservative for quasi-static loads.

Tensile Axial Loading - 250 lb, quasi-static.

Based on the two studies^{90,96} that created bilateral locked facets in experimental situations, they occur at a force of approximately 300-400 lb, when the head is unable to rotate or flex forward about the upper neck. When the facets dislocate the neck undergoes flexion at the inferior end and extension at the superior end, the so-called "ducking" shape. The flexion moment measured at the inferior end is approximately 7.5 ft lb.⁹⁵ No data were found that reported on the moment at the superior end. There is not enough data to completely quantify the situation, but any conditions that have axial loads greater than 250 lbs and place the neck in the ducking configuration with moments on the order of 5-10 ft lb has the possibility of producing a dislocation. The extension moment at the superior end of the specimen is assumed to be similar in magnitude to the flexion moment measured at the inferior end.

Dislocation or Locked Facets — Compressive axial force > 250 lb.

- Upper neck load cell places neck in extension relative to head ($M_y = 5-10$ ft lb).
- Lower neck load cell places neck in flexion relative to torso ($M_y = 5-10$ ft lb).

One of the main advantages to having two load cells in the Hybrid III neck is that the sagittal plane moment (M_y) can be analyzed for just such situations. This criterion for dislocated facets points out the benefit of having both upper and lower neck load cells in ADAM. These changes in neck angles are subtle, and determination of the direction of the lower neck moment from photographic data is difficult, if not impossible. The lower neck load cell, along with the upper neck load cell, provides a means of accurately tracking the shape and load paths through the neck during a dynamic event.

There was no literature highlighted in this review which effectively described dislocations that occur while axial tension is being applied to the neck.

The next level of sophistication for an injury criterion would be to have a dynamic criterion, i.e., one that takes into account the viscoelastic nature of the neck. In order to develop such a criterion, data on fractures produced with loads of varying duration is necessary. Such data is available, but unfortunately the expected viscoelastic effects have apparently been obscured by the effect produced by using different end conditions to support the specimens.

An approach to developing a time-dependent criterion is illustrated with the use of a simple massless viscoelastic element (Kelvin element). Examples of this element are shown in Figure 24. When a force (F) is applied to the element, the spring and the viscoelastic element generate a force such that:

$$F = kx + c\dot{x} \tag{8}$$

where k is the linear spring constant, c is the damping coefficient, x is the deformation and \dot{x} is the velocity of the deformation. In a quasi-static compression, $\dot{x} \approx 0$, all the compression force is used to compress the spring. As the rate of deformation increases, the $c\dot{x}$ term becomes more important and much of the input force goes into overcoming the resistance of the viscous element. For long duration pulses, the maximum strain is related to applied force. For short duration pulses, the maximum strain is related to the applied impulse. An injury criterion for this injury model is set by defining a strain in the element at which an injury occurs.

The coefficients that go into this injury model are based on mean values from the experimental studies. The spring constant k and the injury strain level are based on the data from Nightingale, et al. The mean value of specimen deformation in their six axially-loaded spines was 1.4 cm, and the mean stiffness of the specimens was 343,450 N/m (23,541 lb/ft). The value of the damping coefficient was estimated by calculating the stiffness of the three specimens in McElhaney, et al⁹¹ that had burst fractures and whose force vs deflection curves were published. The mean dynamic stiffness of these three specimens was 434,968 N/m (29,806 lb/ft), which is 27% greater than the stiffness measured during the quasi-static loading. Note that this is less than the 60% increase in stiffness measured in the single specimen that was quasi-statically loaded, and then loaded at 64 cm/sec.⁹¹ However, during these non-failure tests, the specimen was only deformed 0.5 cm.

Figure 22 shows a viscoelastic injury criterion for axial loading with a square wave force pulse. Note that this curve is plotted with linear coordinates. Had it been plotted with logarithmic coordinates, it would have a shape similar to the acceleration-time curve in Figure 4, i.e., it would demonstrate a cross-over point. The injury criterion line is a line of constant strain. Each point on the curve gives the force level and the duration for which the neck can be exposed to that force level without reaching the injury strain. For example, the neck could apparently withstand a 8,896N (2,000 lb) force for 3.5 milliseconds without fracture and a 5,338N (1,200 lb) force for 10 milliseconds without fracture. The 4,804N (1,080 lb) force listed previously as a simple injury threshold number is the static force that the neck can withstand.

This approach to a time-dependent criterion is similar to the criterion proposed by Mertz, et al, whose criterion is also redrawn in Figure 22. The primary difference is that Mertz, et al have placed their quasi-static injury level at 1,112N (250 lb), which is based on the noninjurious static strength of the neck in compression that was measured on human subjects.⁹⁸ By changing the stiffness coefficient of the viscous injury model to $k = 79,358\text{N/m}$ (5,438 lb/ft) in order to reflect this different quasi-static injury level, the injury model produces a curve similar to the Mertz, et al criterion.

A third form for a criterion would be a multi-dimensional injury model where multiple inputs in the model would be used to predict the possibility of injury. An example of such an injury model is a two-dimensional model used to predict cervical fracture caused by the combination of compression loads and moments in the sagittal plane. A simplistic approach to develop such a model would be to assume some relationship between the axial compression force and the

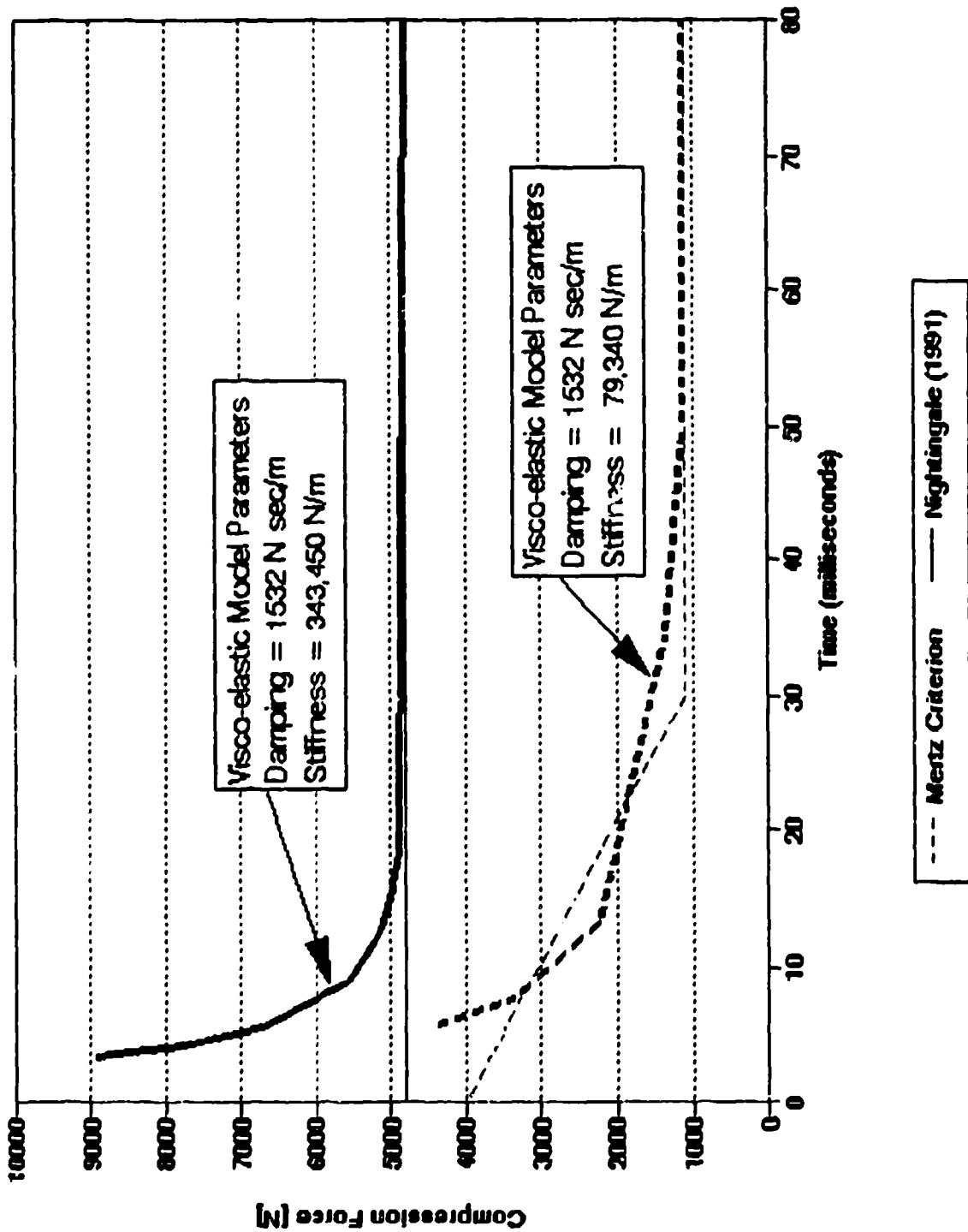

Figure 22. Viscoelastic neck injury model.

moment in the sagittal plane. Only two points are required to establish a linear relationship. Candidates could be the mean value of the fracture of Nightingale, et al⁹⁶ (4,804N (1080 lb)), where insignificant moments were produced, and the mean values of the quasi-static fracture loads for Pintar, et al⁹⁴ (2,300N, 97.6N/m (517 lb, 72 ft lb)). Such a curve is shown in Figure 23 as the straight line labelled quasi-static. The original data from Nightingale, et al⁹⁶ and Pintar, et al⁹⁴ have also been plotted. In the ideal sense the criterion again represents a line of constraint strain. During quasi-static testing any neck outputs from the Hybrid III that place a moment and force combination near this line would indicate a high probability of compression fracture.

Similarly another curve could be drawn to represent a force pulse of shorter duration. The mean pulse duration (constant velocity deformation) for the data of Pintar, et al⁹⁵ was 7 milliseconds and the mean values for the axial force and the flexion moment for this data were 3,509N and 111N/m (789 lb, 82 ft lb) respectively. A quasi-static estimate of fracture load can be obtained from the viscous model for a pulse length of 7 milliseconds, 6,005N (1350 lb) [see Figure 22]. This line is shown in Figure 23 as the dynamic curve. Also shown in Figure 23 are the experimental data points from Pintar, et al.⁹⁵ The dynamic criterion represents a line of constant strain for load applications of approximately 7 milliseconds.

Figure 23 illustrates a number of important points that have been previously discussed. First, there is considerable scatter in the data from study to study, and also within a study. The intrastudy scatter is partially due to variability in test specimens (as a function of age, genetic makeup, gender, etc.) and a lack of complete control of experimental conditions, especially the end conditions of specimens.

Second, the displacement of the dynamic criterion from the quasi-static criterion quantitates the effect of the viscoelastic behavior of the neck. Both lines represent the same constant strain, but for a shorter pulse of 7 milliseconds, higher axial forces and moments can be tolerated before the injury strain is reached.

Third, the plot points out why the viscous effects were hidden by the inclusion of moments with the compressive load. With a pure axial load, the viscous effect can add approximately 1,112N (250 lb) to the quasi-static fracture force when the load is applied over a 7 millisecond span. On the other hand, the inclusion of a 102N/m (75 ft lb) moment can drop the axial load at which the specimen fractures by 600 lb, a much greater effect than can be produced through viscous forces generated in the tissue.

The final form of the recommended injury criterion would take into account injuries produced by the combination of forces and moments (such as the compression fractures that are combinations of axial compressive and bending moments) and the viscoelastic properties of the neck. The input to such a model would be the output data from the neck load cells, and the output of the injury model would be a strain proportional to the probability of injury.

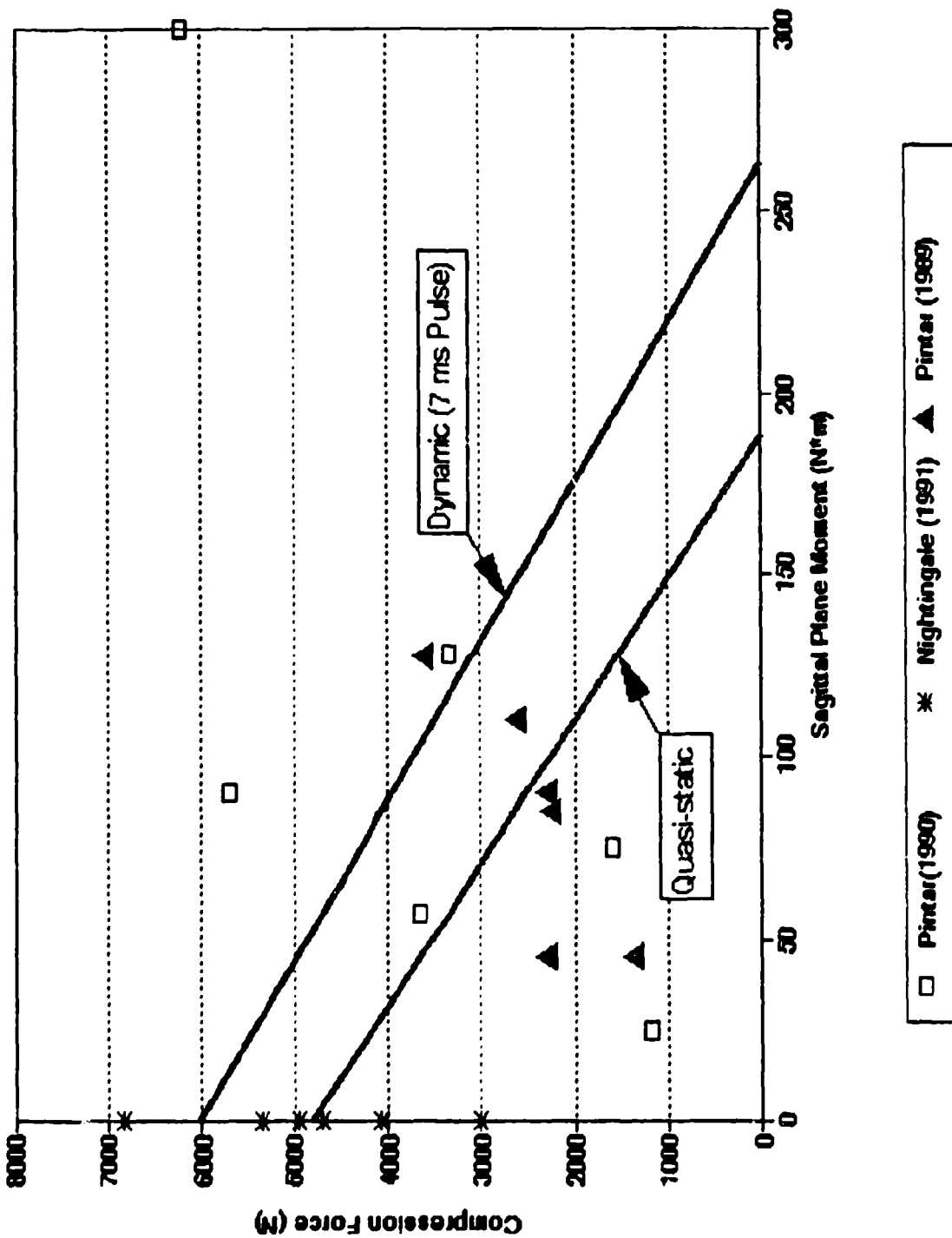

Figure 23. - Two-dimensional neck injury criterion for compression fractures based on the axial compression force and the flexion moment.

A possible form for such criteria is:

$$\text{Form of Neck Criterion} = \left[\left(\frac{|\vec{S}_F|}{S_F \text{ Limit}} \right)^2 + \left(\frac{|\vec{S}_M|}{S_M \text{ Limit}} \right)^2 + \left(\frac{|\vec{S}_F \times \vec{S}_M|}{\text{Cross Product Limit}} \right)^2 \right]^{1/2} \quad (9)$$

where \vec{S}_F is the strain produced by the neck forces, "S_F Limit" is the injury level for the force strain, \vec{S}_M is the strain produced by the moments, "S_M Limit" is the injury level for the moment strain, and the "Cross Product Limit" is the injury strain contribution produced by the coupling of forces and moments. Each of the individual strain components would be calculated with a viscoelastic strain model that would account for the viscoelastic behavior of the neck. Maximum values of the strain vector magnitudes would be used for computation. Figure 24 shows a schematic of how such a model would operate.

The injury criterion shown in Figure 22 is a simplified version of this injury criterion as only the axial load (F_{axial}) and sagittal plane moments (M_y) are considered. A complete injury model would include the lateral (F_{shear_y}) and fore-aft (F_{shear_x}) shear forces and the lateral (M_x) and rotational (M_z) moments.

The addition of the lower neck load cell to ADAM enhances the use of such a criterion. Knowing the force and moment state at each end of the neck enables the force/moment state throughout the length of the neck to be determined through the use of a free body diagram (if the precise geometry of the neck is known). Thus the use of lower neck load cells allows the criterion to be applied at different levels of the neck as well as at both ends.

Unfortunately, insufficient experimental data are available to develop a uniform injury criterion for the multiple force and moment inputs the neck receives. The lack of data enhances the value of the injury model since the model provides a means of extrapolating over areas where no data exists, i.e., provides the vehicle to make an educated guess about injury probability.

One of the primary goals of cervical research is the development of accurate neck injury criteria. The development of a unified neck injury model, even without the supporting experimental data, would provide direction for the experimental work so that the goal can be achieved sooner. The model would point out where gaps in the data exist and allow researchers to design experiments that would generate the data to fill the gaps.

THORACOLUMBAR SPINE

Literature Review

Numerous investigations have assessed thoracolumbar spine injury criteria as reflected in the literature search listing. Comprehensive reviews of note have been presented by Nyquist and

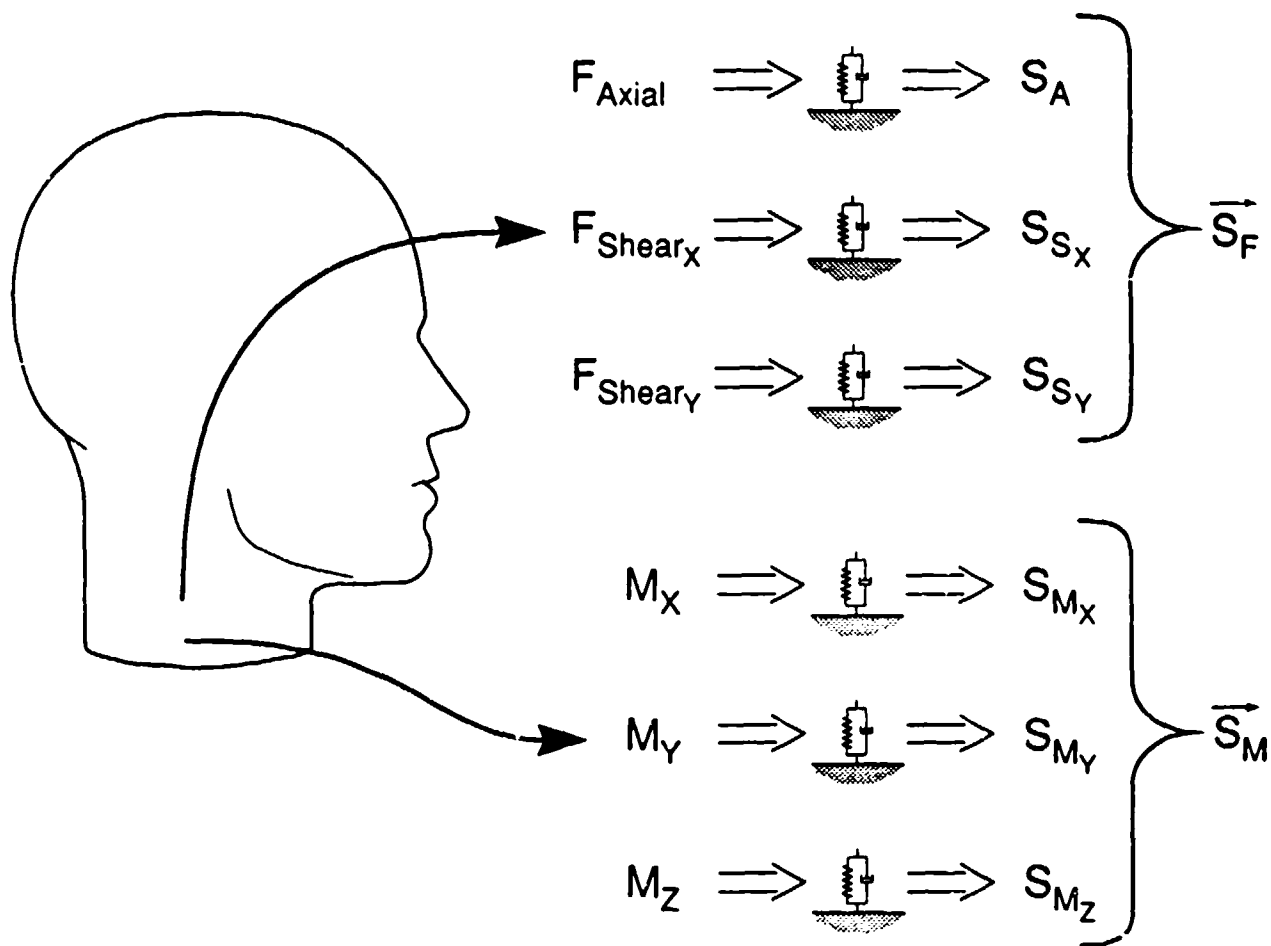

Figure 24. Schematic of injury model that would use all of the ADAM neck data to predict injury.

King in their chapter on the spine as part of the Review of Biomechanical Impact Response and Injury in the Automotive Environment, edited by Melvin and Weber.⁶¹ Other useful publications are "Physiopathology and Pathology of Spinal Injuries" in Aerospace Medicine (Second Edition) by R.P. Delahaye and R. Auffret, AGARD-AG-250(Eng) published in 1982; "The Human Spinal Column and Upward Ejection Acceleration: An Appraisal of Biodynamic Implications" by John H. Henzel, AMRL-TR-66-233, September 1967; and the Handbook of Human Tolerance by McElhany, Roberts and Hillyard, published in 1976. Multiple other useful sources are listed in the references.

Although other human tolerance criteria are noted in the literature such as tension, shear and bending or rotational failure as stated by Yamada in 1970 and reported by Nyquist and King,

the operationally most critical thoracolumbar spine injury mechanism is vertebral body compressive failure, with or without dislocation, as defined in Section 3 of this document. Vertebral compression injury is structural in nature, but the most significant aspect of the injury is the potential functional disturbances from associated neurological deficits. However, neurological injury is an inappropriate basis for an injury criterion since only about 6% of spinal bony injuries have associated spinal cord pathology.

Significant contributions have been made by various investigators whose data on thoracic and lumbar vertebral body compressive failures are summarized in Tables 7 and 8. The data by Ruff (1940) was obtained by static loading of segments of the spine, although he did investigate dynamic states. From the force time histories, he concluded that for loading exposure periods of 5 milliseconds to 1 sec, structural tolerance was determined by the static compressive strength of the most susceptible vertebra, but for forces lasting less than 5 milliseconds the structural tolerance was determined by the dynamic strength of the most susceptible vertebra. Percy (1957) performed dynamic as well as static loading of lumbar vertebral bodies and additionally made differentiations in performance on the basis of age. Percy's values as listed in Table 8 are for subjects under 60 years. Using cadaver specimens, Yoganandan (1985) established microfailure loads as 80% of catastrophic failure loads. Nyquist and King, among others, recognized time dependence as a determinant in compressive load failure levels of thoracolumbar vertebral bodies. The variations noted among the values are in part related to lack of control for subject age and variations in rate of load application.

TABLE 7 - LISTING OF THORACIC COMPRESSIVE FAILURE TESTS		
VERTEBRA	AVERAGE LOAD (KN)	STUDY
T8	5.81	Geertz
	5.25	Crocker & Higgins
	5.85	Ruff
Middle Thoracic	3.38	Yamada
T9	6.62	Geertz
	6.64	Ruff
T10	7.24	Geertz
	7.26	Ruff
T11	7.55	Geertz
	7.56	Ruff
T12	7.80	Geertz
	7.81	Ruff
	9.53	Crocker & Higgins
Lower Thoracic	4.48	Yamada
Thoracolumbar	11.03 (± 1.42)	Yoganandan

TABLE 8 - LISTING OF LUMBAR COMPRESSIVE FAILURE TESTS		
VERTEBRA	AVERAGE LOAD (KN)	STUDY
Thoracolumbar	11.03 (± 1.42)	Yoganandan
L1	7.95/5.09 7.96 11.01	Geertz/Perez Ruff Crocker & Higgins
L2	8.55/5.87 8.56	Geertz/Perez Ruff
L3	9.59/6.21 9.61	Geertz/Perez Ruff
L4	9.62/6.36 9.64	Geertz/Perez Ruff
L5	10.50/5.77 10.52	Geertz/Perez Ruff
Lumbar Vertebrae	5.03	Yamada

A substantial number of pilot ejection studies have yielded data on injury severity and injury location and have established the influence of spine position at ejection as a significant modifier of spine injury.

A number of studies, some using animal materials (Kazarian, Eurell), have been conducted to establish bone failure patterns under thoracolumbar compressive loading at microscopic and macroscopic levels. Some (Eurell) included stress and strain rate dependence as well as ultimate strength determinations in assessing bone responses to compressive stress. The latter studies are indicators of a dynamic response to loading of the thoracolumbar spine.

For the most part, studies relating to failure loads at individual vertebral bodies have found application principally as database sources for parameters to be used in large scale multibody lumped parameter models such as that accomplished by Belytschko.⁹⁹ These models have been used to explore characteristics of the human spine during dynamic response to impact events, but the models have not been amenable to detailed validation at the individual spinal segments for use as an overall injury criterion. Once again, the lumped parameter viscoelastic model has thus far been used most effectively as an overall criterion for injury despite the attendant loss of observability of underlying structural behavior. Clearly, each model has its place and serves effectively in its intended use. The lumped parameter viscoelastic model has its natural application in the definition of pass-fail situations and can, in some cases, serve as an injury probability function.

As previously noted, the foundational work in this area was that of Stech and Payne⁷⁸ in 1969. The original work described the behavior of the human body in response to an impact event in

terms of a simple, single degree-of-freedom viscoelastic model. To quote a prescient statement from Stech and Payne,

"Unfortunately, insufficient experimental data are available at present to describe the dynamic characteristics of all the various tissues involved in the injuries sustained by the human body when it is subjected to large accelerations. Far from precluding the use of the dynamic models, this situation emphasizes the use for them, because they furnish the most accurate description available of dynamic response to acceleration and a logical basis for extrapolation when it is necessary."

Stech and Payne based their Dynamic Response Index approach upon assessments of vertebral stiffness and breaking strengths. Overall natural frequencies were computed and assessed as a function of age. Damping ratios for the model were assessed on the basis of impedance experiments. Damping ratios determined by their method ranged from approximately 0.2 to 0.4. Natural frequencies in their spine model fell in the range from 7 to 9 Hz. Directions were also established to attempt a transverse DRI model for the human body, but these directions were not subsequently pursued with vigor until more recent work by Brinkley.^{100,80}

The Dynamic Response Index could have been approached as a strain model, but its implementation thus far has been defined as an acceleration response model in which the peak resulting acceleration in the mass attached to an accelerating base by a spring-damper system was computed. This approach had some conceptual appeal since the amplified acceleration value observed in the mass was sometimes considered as representing the dynamic amplification observed in portions of the body not well coupled to an accelerating base. The strain approach may be intuitively considered as related to a strain response in tissue necessary to produce injury, but the strain response of the model usually has no directly attributable anatomic analog.

In its application, the DRI has not only demonstrated useful correlation with spinal injury likelihood in occupants utilizing a variety of ejection seats with similar and complex acceleration time histories, but has also been used to successfully predict the likelihood of spinal injury in applications involving other sources of generally vertical impact.

Proposed Criterion

Given the considerable success of the Dynamic Response Index as a usable spinal injury criterion, less attention was focused on the development of a new criterion for spinal injury for use with ADAM. However, the following observations are offered for its implementation.

The typical input to the DRI model is a seat acceleration time curve. Within the ADAM manikin, three linear triaxial accelerometers are mounted in the pelvis and provide a suitable basis for an analogous acceleration curve. These data may be potentially more applicable than seat data since they include the effects on acceleration input to the spine from dynamics of the seat cushion. The implementation would be shown in Equation (10), with \vec{S}_T representing the vector sum of the component strains.

$$\begin{aligned}
 \text{Form of T-L Spine Criterion (Acceleration)} = & \left[\left(\frac{|\bar{S}_X|_{\text{MAX}}}{S_X \text{ Limit}} \right)^2 + \left(\frac{|\bar{S}_Y|_{\text{MAX}}}{S_Y \text{ Limit}} \right)^2 \right. \\
 & \left. + \left(\frac{|\bar{S}_Z|_{\text{MAX}}}{S_Z \text{ Limit}} \right)^2 + \left(\frac{|\bar{S}_Z \times \bar{S}_T|_{\text{MAX}}}{\text{Cross Product Limit}} \right)^2 \right]^{1/2} \quad (10)
 \end{aligned}$$

Other alternative sources of data available within ADAM include a six-axis load cell mounted at the lower end of the lumbar spine. This device provides data which includes two orthogonal shear forces as well as an axial load measurement in the spine and three orthogonal moment measurements. These are measurements of force and torque instead of acceleration and are not directly comparable to the acceleration time history conventionally used as input to the DRI. Two alternative approaches to viscoelastic models can be envisioned with force or torque as the input. One approach would be to use the conventional spring-mass-damper model allowing conventional assignment of parameters to yield the observed model natural frequency. However, instead of accelerating the base, a force input could be mathematically applied directly to the mass. The other approach would be to omit the mass altogether and utilize a direct force input to a Kelvin unit formed by a spring and damper arranged in parallel. For evaluation of the typical ejection-related thoracolumbar compression injury, the principal strain model would be that based upon axial force. However, the output of the other five load cell channels from the lumbar unit could also be evaluated using spring-damper models allowing the formulation of a two-component shear strain vector and a three-component moment vector. These could be employed, as shown in Equation (11), to define an overall approach to viscoelastic modelling of the spine with assessment of interaction between axial compression and simultaneously applied shear or bending forces moments. The approach is diagrammed in Figure 25.

$$\begin{aligned}
 \text{Form of T-L Spine Criterion (Force)} = & \left[\left(\frac{|\bar{S}_A|_{\text{MAX}}}{S_A \text{ Limit}} \right)^2 + \left(\frac{|\bar{S}_M|_{\text{MAX}}}{S_M \text{ Limit}} \right)^2 \right. \\
 & \left. + \left(\frac{|\bar{S}_A \times \bar{S}_M|_{\text{MAX}}}{\text{Cross Product Limit}} \right)^2 + \left(\frac{|\bar{S}_S|_{\text{MAX}}}{S_S \text{ Limit}} \right)^2 \right]^{1/2} \quad (11)
 \end{aligned}$$

For the near term, each of the variable terms in the equation could be treated as a separate criterion. The most prominent of these, of course, for current use, would be the axial term. Use of the multiterm approach as the principal injury criterion may allow greater specificity in the ADAM application to predict injury in circumstances where the ADAM manikin is less well coupled to the seat or in the case of stresses other than those which are principally vertical or aligned with the spinal axis.

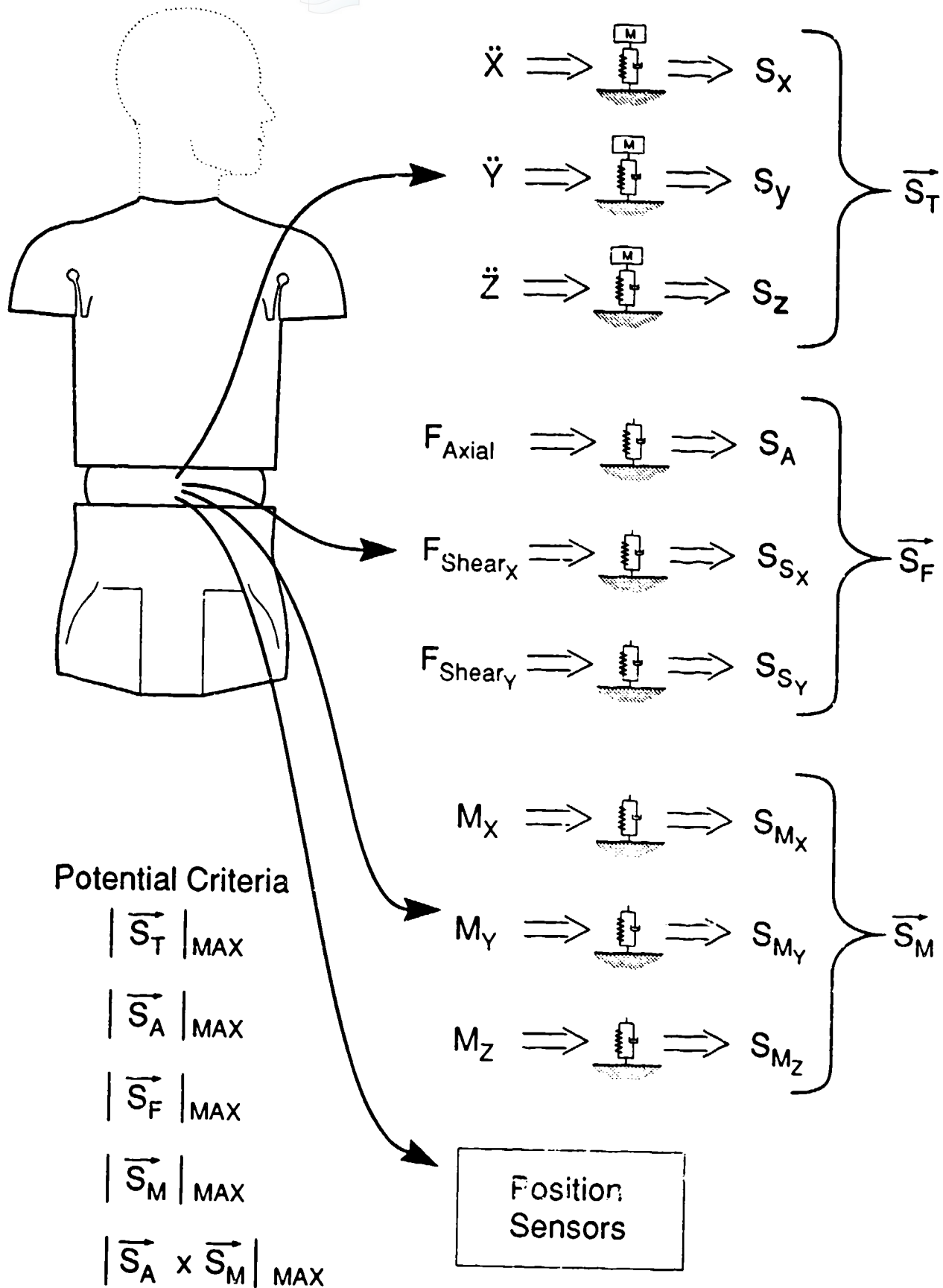

Figure 25.

CHEST AND ABDOMEN

Literature Review

As defined in Section 3, it is believed that the operational incidence of significant thoracic and abdominal injury does not merit the development of separate injury criteria. Furthermore, the localized nature of injuries to soft tissue structures makes the instrumentation problem more difficult for incorporation into a practical ATD. However, studies have been instituted to explore that potential. Noteworthy among these is the recent study by Schneider, et al¹⁰¹ sponsored by the US Department of Transportation and published in November 1989. The data on thoracic and abdominal impact response to a variety of stressors is reviewed as well as a review of injury mechanisms for structures within these body regions. Injury criteria are discussed, including notions of absorbed energy as a metric, based upon a suggestion by Eppinger and Marcus. However, due to the attendant difficulties in instrumentation design, approaches employing measurement of displacement, velocity, or acceleration are settled for. The previously discussed viscous criterion for the chest, in which the velocity of displacement as multiplied by the percentage of strain in an antero-posterior (AP) direction, is employed. The approaches for the abdomen appeared less satisfactory, but a viscous criterion approach was also recommended there. Redesigned alternatives for instrumentation of the chest and abdomen are explored as well. If chest or abdominal injury criteria should be required for future applications of ADAM, this work serves as a suitable basis for considering instrumentation requirements. However, it would appear that a suitable definition of an injury criterion or criteria for the abdomen must await further experimental substantiation.

UPPER AND LOWER EXTREMITIES

Literature Review

Assessment of long bone fracture differs conceptually from the study of tolerance to short duration loads for the head and the multi-element neck, and thoracolumbar spine. The long bones of the extremities represent individual structural elements composed of cortical and cancellous bone. Bone is the basic structural element providing support to the soft tissues of the body and appropriately achieves its greatest strength in compression. Fractures tend to initiate at points of local tension with fracture lines typically propagating rapidly if the stress is maintained following fracture initiation. Bone has been noted to be a viscoelastic structure responding to stresses with both elastic and plastic behavior. Behavior of extremity long bones under short duration loading has been investigated principally in conjunction with the study of automotive crash injury. These studies have most often centered upon stresses applied to the lower extremity. In particular, attention has centered upon axial loading of the femur with forces typically applied at the knee with the hip and knee flexed. These data have been pursued vigorously as a result of requirements stemming from the Federal Motor Vehicle Safety Standards and the various approaches which have used knee bolsters as forward restraint components for frontal crash protection. Reasonable reviews are available in Melvin and Webber, as well as The Handbook of Human Tolerance by McElhaney, et al.

Various authors have studied static breaking strength for the femur. Results of these led to the adoption of a constant femur axial load limit of 7,600 newtons (1,700 lbs). However, a variety of studies have demonstrated that femur tolerance increases substantially for shorter duration loading events. King, et al¹⁰² described a substantial increase in tolerance to axial loading for short duration events. They proposed a rate-dependent model allowing substantially increased loads for shorter duration pulses. King, et al also pointed out an observed amplification of the applied input pulse for load sensing devices in a VIP-50 dummy femur load cell. These observations argued strongly for an approach to femur injury criterion definition which took into account the viscoelastic characteristics both of the human femur and the test surrogate. Viano published significant papers on femur injury criteria in 1976 with Khali¹⁰³ and in 1977.¹⁰⁴ In the first, he demonstrated an interesting behavior in dynamic femur fracture characteristics. The average fracture load decreases somewhat below static fracture load levels for pulse durations in the 20 to 45 millisecond range. He believed this to be related to the stimulation of a structural resonance in that region. For shorter duration pulses (below 20 ms) axial loads necessary to produce fracture increased dramatically. Viano's curves were not unlike those found for the response of a viscoelastic model. In the second paper, Viano proposed a femur injury criterion of the form reproduced in Figure 26. Again, the form of the proposed criterion is amenable to modeling using a constant strain approach for a viscoelastic system. The resonance behavior noted by Viano would indicate the selection of a damping ratio in the range of 0.2 to 0.3. Bending and torsion behavior for the femur appears to have some similarity to the rate-dependent characteristics of the axial load response.

Knee behavior under loading has been studied by Noyes while at the Aerospace Medical Research Laboratory and later with Grood at the University of Cincinnati. In the report by Grood, et al¹⁰⁵, knee flail design limits for escape were assessed based upon experimental data. These authors evaluated strain rate sensitivity and found relatively little strain rate sensitivity for ligament at rates consistent with moderate activity, but saw significant strain rate effects related to bony attachments. The authors suggested design limits, including ranges for tibial rotation (17.5° internal and 20° external). Since the ADAM manikin does not allow this range of motion, an angular tibial rotation limit is not feasible for the specification of a knee injury criterion. However, given the potential for instrumenting the femur and/or tibia for axial loads and moments, the analysis outlined in Section 4 can be used as the basis for assessing knee injury potential using instrumentation placed in the surrogate long bones. The chosen injury criteria for bending may be driven more by knee failure characteristics than by femur behavior.

For observability of forces relevant to the knee, load cell instrumentation in the long bones of the femur or tibia should be placed as close as possible to the knee. Minimum instrumentation to provide some assessment of joint torque potential at the knee and for the femur would require a single load cell inserted for the femur in the most distal practical location. The optimum instrumentation complement for observability in the lower extremity would be that as defined in Section 4. However, this would employ five-axis load cells, both in a proximal and a distal location for the femur. Only one of the load cells would instrument axial force while the other would instrument torsion. Sufficient data appears to be available, at least for the femur, to find approximate injury criteria using at least a subset of these outputs. The minimum configuration

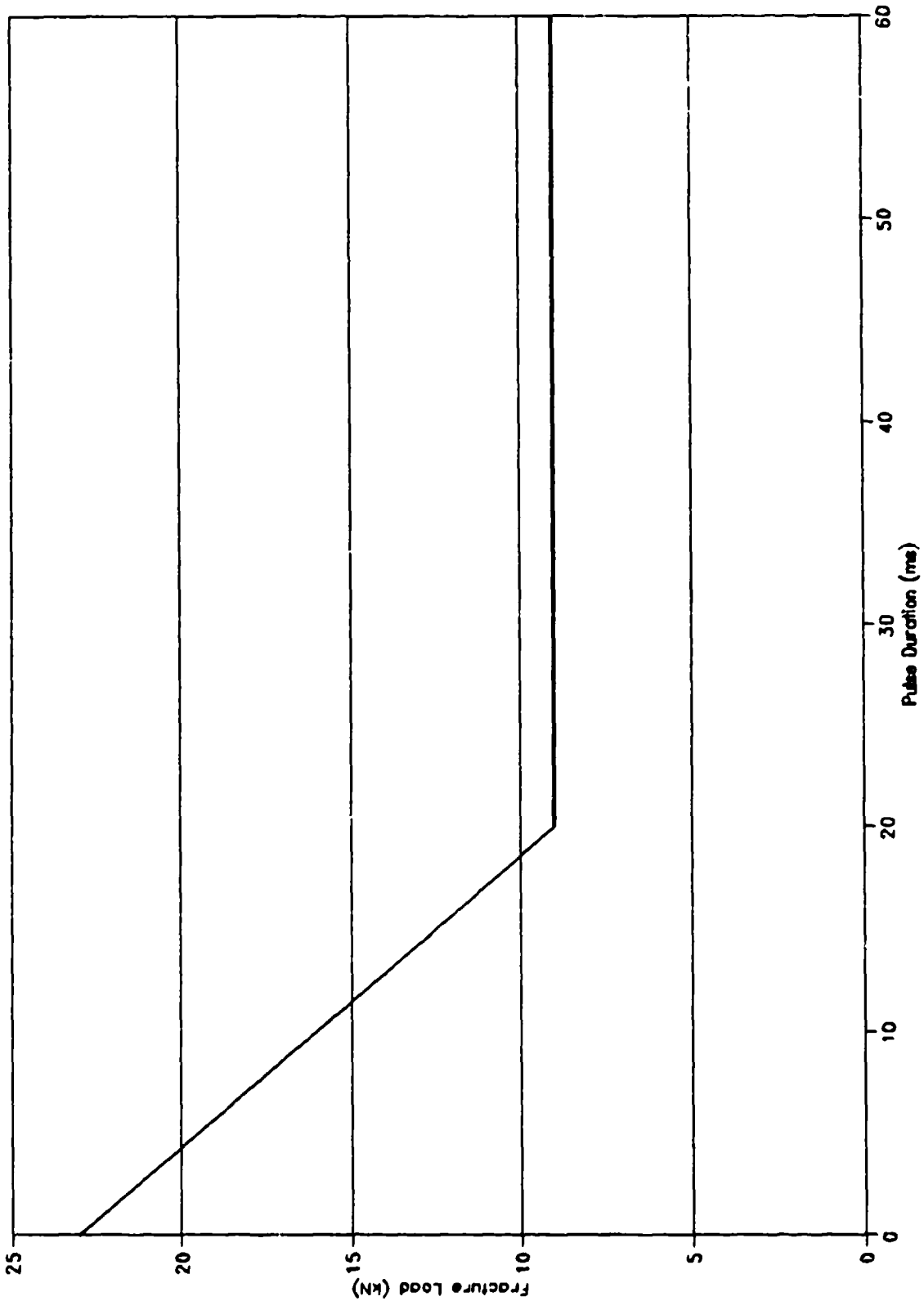

Figure 26. Femur Injury Criterion from Viano

would involve a six-axis load cell placed distally in the femur to assess both knee torques and femur loads as outlined in Figure 27. The eventual criterion might be approached as shown in Equation (12). Again, for the near-term, the variable terms could be treated separately with the most significant terms being the moment and force terms.

$$\begin{aligned}
 \text{Form of Leg Criterion} = & \left[\left(\frac{|\vec{S}_A|_{MAX}}{S_A \text{ Limit}} \right)^2 + \left(\frac{|\vec{S}_M|_{MAX}}{S_M \text{ Limit}} \right)^2 \right. \\
 & \left. + \left(\frac{|\vec{S}_A \times \vec{S}_M|_{MAX}}{\text{Cross Product Limit}} \right)^2 + \left(\frac{|\vec{S}_S|_{MAX}}{S_S \text{ Limit}} \right)^2 \right]^{1/2} \quad (12)
 \end{aligned}$$

Hip joint injuries and even lower extremity disarticulations have been observed in ejections at extreme speeds. However, the incidence of these injuries does not appear to merit the development of an injury criterion. Available hip joint data in the literature center on the effects of axial femur loading into the acetabulum.

Substantially less data exist for the other long bones, but their behavior would be expected to be generally similar to that of the femur. Quasi-static bending and torsion strength for the humerus appears to be in the range of 30 to 40% of the values for the femur, according to McElhaney, et al. Significant variation occurs with age. Both the lower arm and lower leg involve two bones per segment with the tibia characteristics predominating for the lower extremity and a transition occurring from proximal to distal with regard to the dominant structure in the forearm. The decreased incidence of distal as opposed to proximal extremity injuries would imply that the principal candidates for instrumentation in a limited approach would be the distal femur and the distal humerus. A feasible instrumentation subset scheme is illustrated in Figure 28.

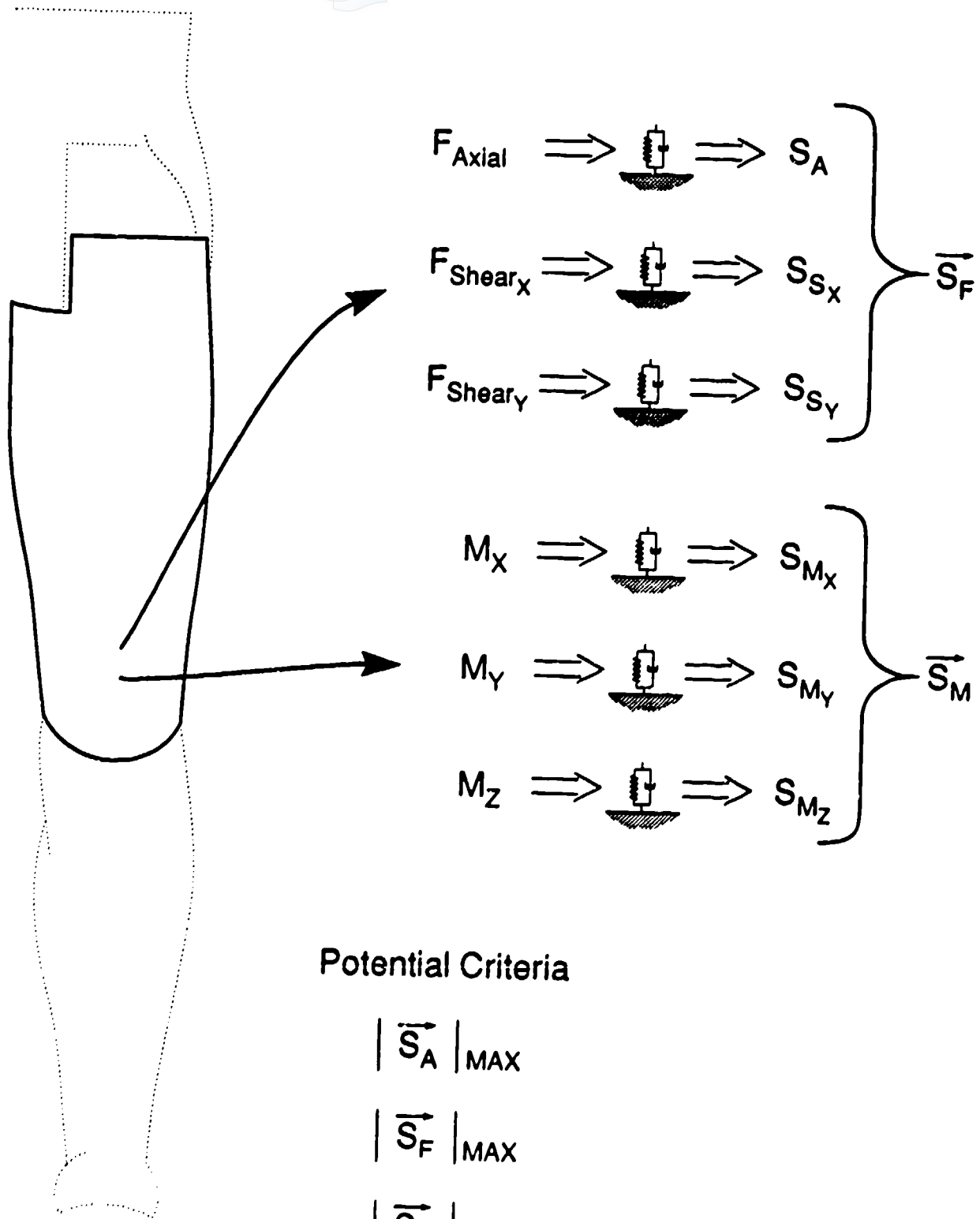

Potential Criteria

$$|\vec{S}_A|_{MAX}$$

$$|\vec{S}_F|_{MAX}$$

$$|\vec{S}_M|_{MAX}$$

$$|\vec{S}_A \times \vec{S}_M|_{MAX}$$

Figure 27.

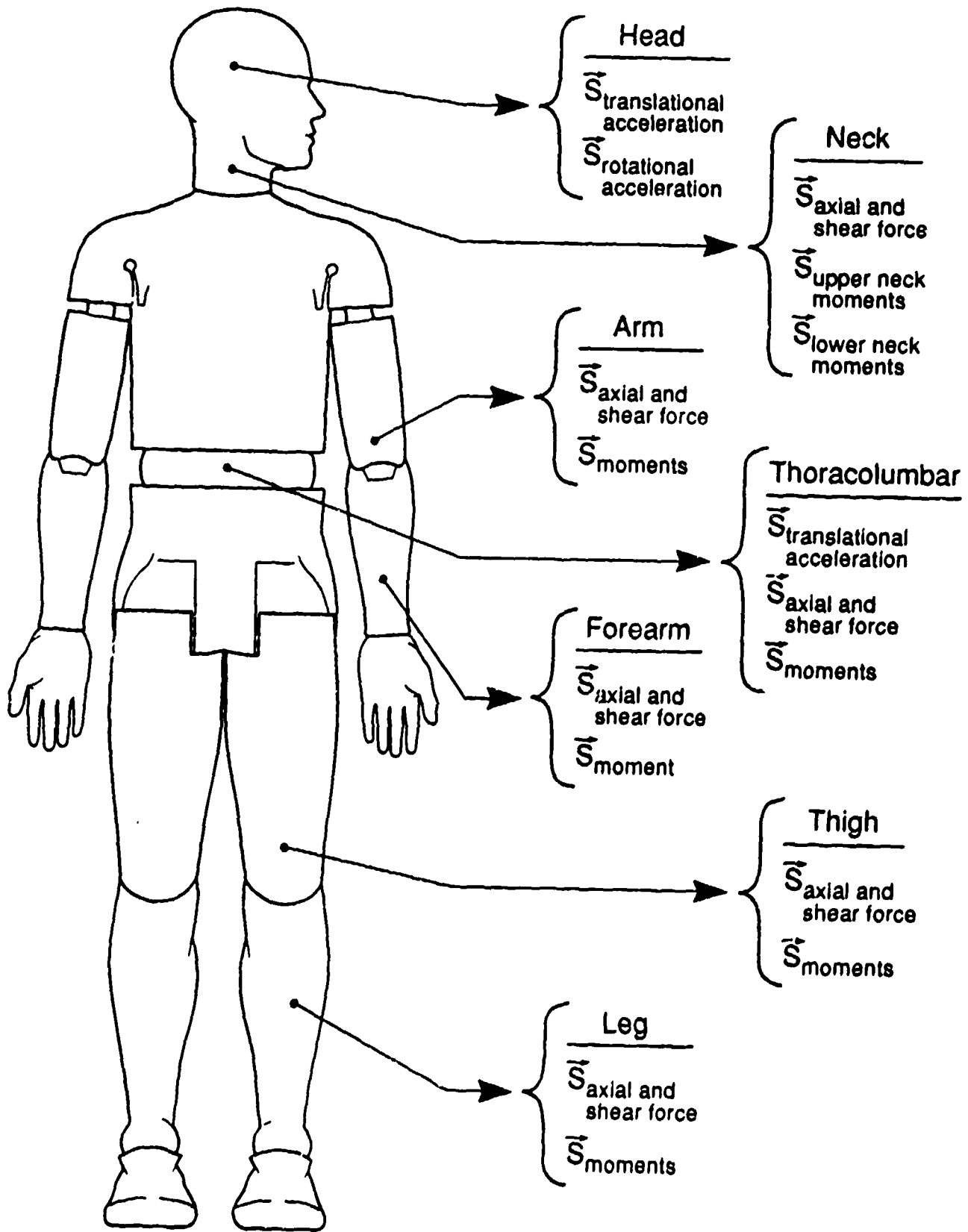

Figure 28.

REFERENCES FOR SECTION 5:

61. Melvin, J.W., Weber, K, eds. Review of Biomechanical Impact Response and Injury in the Automotive Environment. Final Report June 1983-March 1985. Washington, D.C., U.S. Department of Transportation, National Highway Traffic Safety Administration. DOT-HS-807-042, March 1985.
62. Lombard, C.F., Ames, S.W., Roth, H.P., Rosenfeld, S. Voluntary Tolerance of the Human to Impact Accelerations of the Head. *J Aviat Med Suppl*, 2(6), 109-16 (1951 Dec).
63. Foust, D.R., Bowan, B.M., Snyder, R.G. Study of Human Impact Tolerance Using Investigations and Simulations of Free-falls. Proceedings of the 21st Stapp Car Crash Conference, New Orleans, LA, October 19-21, 1977, (Society of Automotive Engineers Proceedings No. P-73). Warrendale, PA, Society of Automotive Engineers, 1-52 (1977).
64. Hodgson, V.R., Thomas, L.M. Breaking Strength of the Human Skull Vs. Impact Surface Curvature. Final Report June 30, 1970-June 30, 1971. Washington, D.C., U.S. Department of Transportation, National Highway Traffic Safety Administration, 1971.
65. Gurdjian, E.S., Roberts, V.L., Thomas, L.M. Tolerance Curves of Acceleration and Intracranial Pressure and Protective Index in Experimental Head Injury. *J Trauma*, 6(5), 600-604 (1966 Sep).
66. Ommaya, A.K., Fisch, F.J., Mahone, R.M., Corrao, P., Letcher, F. Comparative Tolerances for Cerebral Concussion by Head Impact and Whiplash Injury in Primates. Proceedings of the International Automobile Safety Conference, Detroit, MI, May 13-15, 1970, (Society of Automotive Engineers Proceedings No. P-30). New York, NY, Society of Automotive Engineers, 808-17 (1970).
67. Ommaya, A.K., Hirsch, A.E. Tolerances for Cerebral Concussion from Head Impact and Whiplash in Primates. *J Biomech*, 4(1), 13-21 (1971 Jan).
68. Unterharnscheidt, F.J. Translational Versus Rotational Acceleration: Animal Experiments with Measured Input. Proceedings of the 15th Stapp Car Conference, Coronado, CA, November 17-19, 1971. (Society of Automotive Engineers Proceedings No. P-39). New York, NY, Society of Automotive Engineers, 767-70 (1971).
69. Gennarelli, T.A., Thibault, L.E., Ommaya, A.K. Pathophysiologic Responses to Rotational and Translational Accelerations of the Head. Proceedings of the 16th Stapp Car Crash Conference, Detroit, MI, November 8-10, 1972, (Society of Automotive Engineers Proceedings No. P-45). New York, NY, Society of Automotive Engineers, 296-308 (1972).
70. Versace, J. A Review of the Severity Index. Proceedings of the 15th Stapp Car Crash Conference, Coronado, CA, November 17-19, 1971, (Society of Automotive Engineers Proceedings No. P-39). New York, NY, Society of Automotive Engineers, 771-96 (1971).
71. Brinn, J., Staffeld, S.E. The Effective Displacement Index—An Analysis Technique for Crash Impacts of Anthropometric Dummies. Proceedings of the 15th Stapp Car Crash Conference, Coronado, CA, November 17-19, 1971, (Society of Automotive Engineers Proceedings No. P-39). New York, NY, Society of Automotive Engineers, 742-66 (1971).

72. Fan, W.R. **Internal Head Injury Assessment**. Proceedings of the 15th Stapp Car Crash Conference, Coronado, CA, November 17-19, 1971, (Society of Automotive Engineers Proceedings No. P-39). New York, NY, Society of Automotive Engineers, 645-65 (1971).
73. Stalnaker, R.L., McElhaney, J.H., Roberts, V.L. **MSC Tolerance Curve for Human Head Impacts**. (ASME Pap 71-WA/BHF-10), Contributed by the Biomechanics and Human Factors Division of the American Society of Mechanical Engineers for presentation at the ASME Winter Annual Meeting, Washington, D.C., November 28-December 2, 1971.
74. Stalnaker, R.L., Alem, N.M., Benson, J.B. **Validation Studies for Head Impact Injury Model**. Final Report July 1, 1973-August 31, 1975. Washington, D.C., U.S. Department of Transportation, National Highway Traffic Safety Administration. DOT-HS-802-566, September 1977.
75. Melvin, J.W., Mohan, D., Stalnaker, R.L. **Occupant Injury Assessment Criteria**. (Society of Automotive Engineers Technical Paper No. 750914). Warrendale, PA, Society of Automotive Engineers, 2483-2494 (1975).
76. Goldsmith, W., Ommaya, A.K. **Head and Neck Injury Criteria and Tolerance Levels**. IN: Aldman, B. And Chapon, A., Eds. **The Biomechanics of Impact Trauma**. Amsterdam, Netherlands, Elsevier: 149-87 (1984).
77. Gennarelli, T.A., Thibault, L.E. **Acceleration Damage to the Brain**. IN: **Impact Injury Caused by Linear Acceleration: Mechanisms, Prevention and Cost**. Neuilly-sur-Seine, France, Advisory Group for Aerospace Research and Development. AGARD-CP-322, 10-1-10-9 (1982).
78. Stech, E.L., Payne, P.R. **Dynamic Models of the Human Body (Joint NASA/USAF Study)**. AMRL-TR-66-157, November 1969.
79. Viano, D.C., Lau, I.V. **A Viscous Tolerance Criterion for Soft Tissue Injury Assessment**. *J Biomech*, 21(5), 387-399 (1988).
80. Brinkley, J.W., Specker, L.J., Mosher, S.E. **Development of Acceleration Exposure Limits for Advanced Escape Systems**. IN: **Implications for Advanced Technologies for Air and Spacecraft Escape**. Neuilly-sur-Seine, France, Advisory Group for Aerospace Research and Development, AGARD-CP-472, 1-1-1-14 (1990).
81. Ono, K., Kikuchi, A., Nakamura, M., Kobayashi, H., Nakamura, N. **Human Head Tolerance to Sagittal Impact Reliable Estimation Deduced from Experimental Head Injury Using Subhuman Primates and Human Cadaver Skulls**. Proceedings of the 24th Stapp Car Crash Conference, Troy, MI, October 15-17, 1980, (Society of Automotive Engineers Proceedings No. P-88). Warrendale, PA, Society of Automotive Engineers, 103-60 (1980).
82. Culver, R.H., Bender, M., Melvin, J.W. **Mechanisms, Tolerances, and Responses Obtained Under Dynamic Superior-Inferior Head Impact: A Pilot Study**, Morgantown, WV, National Institute for Occupational Safety and Health. UM-HSRI-78-21, May 1978.
83. Hodgson, V.R., Thomas, L.M. **Mechanisms of Cervical Spine Injury During Impact to the Protected Head**. Proceedings of the 24th Stapp Car Crash Conference, Troy, MI, October 15-18, 1980, (Society of Automotive Engineers Proceedings No. P-88). Warrendale, PA, Society of Automotive Engineers, 17-42 (1980).

84. Nusholtz, G.S., Kaiker, P.S. Kinematics of the Human Cadaver Cervical Spine in Response to Superior-Inferior Loading of the Head. Final Technical Report. Ann Arbor, MI, University of Michigan, Transportation Research Institute, UMTRI-86-31, July 1986.
85. Alem, N.M., Nusholtz, G.S., Melvin, J.W. Head and neck response to axial impacts. Proceedings of the 28th Stapp Car Crash Conference, Chicago, IL, November 6-7, 1984, (Society of Automotive Engineers Proceedings No. P-152). Warrendale, PA, Society of Automotive Engineers, 275-88 (1984).
86. Mertz, H.J., Hodgson, V.R., Thomas, L. Murray, Nyquist, G.W. An Assessment of Compressive Neck Loads Under Injury Producing Conditions. Physician Sportsmed, 6(3) 95-100, 103-4, 106 (Nov 1978).
87. Nyquist, G.W., Begman, P.C., King, A.I., Mertz, H.J. Correlation of Field Injuries and GM Hybrid III Dummy Responses for Lap-Shoulder Belt Restraint. J Biomech Eng, 102, 103-9 (May 1980).
88. Mertz, H.J. Injury Assessment Values Used to Evaluate Hybrid III Response Measurements. Safety and Crashworthiness Systems, General Motors Corporation, February 1984.
89. Roaf, R. Study of Mechanics of Spinal Injury. J Bone Joint Surg [Br], 42(4), 810 (Nov 1960).
90. Bauze, R.J.; Ardran, G.M. Experimental Production of Forward Dislocation in the Human Cervical Spine. Publication unknown. Vol. 60-B, No. 2, May 1978. pp. 239-?
91. McElhaney, J.H., Paver, J.G., McCrackin, H.J., Maxwell, G.M. Cervical Spine Compression Responses.
92. Maiman, D.J., Sances, A. Jr., Myklebust, J.B., Larson, S.J., Houterman, C., Chilbert, M., El-Ghatit, A.Z. Compression Injuries of the Cervical Spine: a Biomechanical Analysis. Neurosurgery, 13(3), 254-60 (1983 Sep).
93. McElhaney, J.H., Doherty, B.J., Paver, J.G., Myers, B.S., Gray, L. Combined Bending and Axial Loading Responses of the Human Cervical Spine. Proceedings of the 32nd Stapp Car Crash Conference, Atlanta, GA, October 17-19, 1988. (Society of Automotive Engineers Proceedings No. P-215). Warrendale, PA, Society of Automotive Engineers, 21-8, (1988).
94. Pintar, F.A., Yoganandan, N., Sances, A. Jr., Reinartz, J., Harris, G., Larson, S.J. Kinematic and Anatomical Analysis of the Human Cervical Spinal Column Under Axial Loading. Proceedings of the 33rd Stapp Car Crash Conference, Washington, D.C., October 4-6, 1989, (Society of Automotive Engineers Proceedings No. P-227). Warrendale, PA, Society of Automotive Engineers, 191-214 (1989).
95. Pintar, F.A., Sances, A. Jr., Yoganandan, N., Reinartz, J., Maiman, D.J., Suh, J.K. Biodynamics of the Total Human Cadaveric Cervical Spine. Proceedings of the 34th Stapp Car Crash Conference, Orlando, FL, November 4-7, 1990, (Society of Automotive Engineers Proceedings No. P-236). Warrendale, PA, Society of Automotive Engineers, 55-72 (1990).
96. Nightingale, R.W., Doherty, B.J., Myers, B.S., McElhaney, J.H., Richardson, W.J. The Influence of End Condition On Human Cervical Spine Injury Mechanisms. Proceedings of the 35th Stapp Car Crash Conference, San Diego, CA, November 18-20, 1991 (Society of Automotive Engineers Proceedings No. P-251). Warrendale, PA, Society of Automotive Engineers, 391-9 (1991).
97. Miller, L.S., Cotler, H.B., De Lucia, F.A., Cotler, J.M., Hume, E.L. Biomechanical Analysis of Cervical Distraction. Spine 1987 Nov, 12(9), 831-7.

98. Mertz, H.J., Patrick, L.M. Strength and Response of the Human Neck. Proceedings of the 15th Stapp Car Crash Conference, Coronado, CA, November 17-19, 1971, (Society of Automotive Engineers Proceedings No. 710855). New York, NY, Society of Automotive Engineers, 207-55 (1971).
99. Belytschko, T., Privityzer, E. Refinement and Validation of a Three-Dimensional Head-Spine Model. AMRL-TR-78-7, August 1978.
100. Brinkley, J.W. Acceleration Exposure Limits for Escape System Advanced Development. SAFE J, 15, 10-16 (1985 Summer).
101. Schneider, L.W., King, A.I., Beebe, M.S. Design Requirements and Specifications: Thorax—Abdomen Development Task. Interim Report. Trauma Assessment Device Development Program. Washington, D.C., U.S. Department of Transportation, National Highway Traffic Safety Administration. DOT-HS-807-511, November 1989.
102. King, J.J., Fan, W.R., Vargovick, R.J. Femur Load Injury Criteria—a Realistic Approach. Proceedings of the 17th Stapp Car Crash Conference, Oklahoma City, OK, November 12-13, 1973. (Society of Automotive Engineers Proceedings No. P-51). Warrendale, PA, Society of Automotive Engineers, 509-24 (1973).
103. Viano, D.C., Khalil, T.B. Investigation of Impact Response and Fracture of the Human Femur by Finite Element Modeling. IN: Mathematical Modeling Biodynamic Response to Impact, (Society of Automotive Engineers Publication No. SP-412). Warrendale, PA, Society of Automotive Engineers, 53-60 (1976).
104. Viano, D.C. Considerations for a Femur Injury Criterion. Proceedings of the 21st Stapp Car Crash Conference, New Orleans, LA, October 19-21, 1977, (Society of Automotive Engineers Proceedings No. P-73). Warrendale, PA, Society of Automotive Engineers, 445-73 (1977).
105. Grood, E., Noyes, F., Butler, D. Knee Flail Design Limits: Background, Experimentation and Design Criteria. AMRL-TR-78-58, October 1978.

SECTION 6

OUTLINE OF VALIDATION APPROACH

SECTION 6

OUTLINE OF VALIDATION APPROACH

OBJECTIVES OF THE PROGRAM

The preceding sections have outlined a comprehensive conceptual approach to a regional viscoelastic strain modeling approach for the definition of injury criteria for the head, neck, thoracolumbar spine, and extremities. The approach has been based largely on a conceptual formulation after thoughtful examination of historical ejection injury experience and major themes in the literature relating to injury to the human body through application of mechanical force. Only brief, anecdotal comparisons of the form of the injury criteria models have thus far been accomplished. For the most part, only the conceptual form of the model has been proposed.

In order to apply the approach in a comprehensive fashion to the ADAM program, substantial additional instrumentation requirements are apparent. Furthermore, the associated validation program would be not only aggressive, but impractical in the near term. The basis for this assessment is not only the extensive instrumentation requirements and the statistical experimental design considerations, but also the lack of availability of suitable subsystem data over the range of relevant frequencies necessary for final formulation of injury criteria model parameters. Despite these limitations, we believe that the recommended approach to the definition of regional injury criteria remains the most advantageous approach to achieve a consistent rational basis for human injury criteria definition.

It is important to note that the chosen injury criteria approach has critical implications in the validation of the overall mechanical response of the ADAM manikin. The use of the manikin for testing against regional injury criteria was predicated on the validity of the manikin's regional response. However, the use of injury criteria which are highly frequency-dependent implies that the manikin must respond faithfully for mechanical force inputs over the relevant range of frequencies. Quasi-static validation of manikin response is inadequate. Realistic manikin frequency response characteristics must be assured as a predicate for injury criteria.

It is recommended that the regional injury criteria approach be pursued by defining a practical, achievable next step that both addresses ADAM requirements and responds to needs in the larger biomechanical community for more comprehensive and realistic injury criteria. Such a practical next step is recommended along the following lines. First, a manageable subset of injury types should be defined based upon Air Force requirements, larger community requirements, and the availability of necessary subsystem data. During this selection process, experimental data gaps on a subsystem level should be highlighted for potential pursuit by experimental groups working with biological materials. Potential candidate injury types for near term selection and validation might include a comprehensive head injury criterion incorporating translational and angular acceleration stress and the definition of injury criteria for bending stress applied to proximal extremity long bones. These injury types would explore regions of interest to the US Air Force

and the general community with reasonable databases in the literature while imposing practical instrumentation requirements for near term employment with ADAM.

Next, the selected injury criteria would be qualitatively defined based upon a detailed review of the current experimental database and a comprehensive comparison with previous criteria. This effort would extend the present conceptual development of the form of the requisite injury criteria into a quantitative numerical proposal.

The third step would be to instrument an ADAM manikin to provide data to serve as inputs to the selected criterion models. The instrumented manikin would then be employed in a sequence of subthreshold and suprathreshold subsystem and system test evaluations. The philosophy of the proposed validation program will first be discussed, followed by an outline of a proposed validation program.

PHILOSOPHY OF CRITERIA VALIDATION

Validation of proposed models has been approached in the past with varying degrees of sophistication. Some validation efforts amount to simple curve-fitting exercises. These may demonstrate that the overall output of a model has the appropriate form to allow the generation of data comparable to some parameter, but often does not imply that the assumptions, coefficients, and values for internal model variables as a function of time are necessarily representative of the process being modeled. This may be the case in some finite element models in which overall motions may duplicate test results, but values for internal stresses and strains within the elements making up the model may not be representative of true subsystem values.

In the case of the lumped parameter injury criteria models proposed in this paper, specific internal model parameters are not expected to be representative of analogous strain behavior in the modeled system. Furthermore, as discussed previously, the injury criterion models do not represent tolerance curves for a particular injury. Instead, the purpose of the injury criterion model is to distinguish stress with low probability for injury to the modeled system from stresses with high probability for injury. In the ideal case, a criterion may allow estimation of likelihood of certain classes of injury for a given stress but, to be useful as a criterion, an acceptable probability must be selected and the criterion used in testing to determine whether or not a given test output showed performance within acceptable levels.

For meaningful validation to be achieved, a criterion should be demonstrably of the correct form so that stresses of different magnitudes, pulse shapes, and durations would yield results that faithfully follow the injury behavior, but not necessarily the physical behavior of the modeled system when subjected to similar stress variations. Secondly, an appropriate criterion with the correct form of response should also be defined at the appropriate level to consistently provide relevant assessments of injury likelihood. In other words, the output of the injury criterion model should be of the appropriate form and at the appropriate level to model the injury behavior being sought.

Errors in modeling the correct form of response will generally lead to errors in comparing stresses with different pulse shapes and durations. Errors in setting the appropriate level for the criterion will result in erroneous assessments of injurious stress magnitudes across the board.

The basic philosophy proposed in the validation program is to conduct a combination of subthreshold and suprathreshold tests at both the subsystem and system level for a relevant range of pulse shapes, durations, and magnitudes. Four fundamental requirements should underline the definition of tests under such a program. The four requirements, treated in the following paragraphs, deal with the relevance and repeatability of the stress and the relevance and repeatability of the result.

Tests conducted with the ADAM manikin for validation should ultimately deal with stresses having frequency characteristics similar to those encountered in the operationally injurious settings. Stresses should also be imposed over a range of magnitudes that will allow observability of the required discrimination being sought in the injury criterion. In other words, the criterion will not be adequately assessed if only clearly injurious and clearly non-injurious stresses are applied. In general, the most relevant stresses are typically encountered in system testing as opposed to subsystem testing. Unfortunately, subsystem testing allows the greatest degree of repeatability in the imposition of stresses. A full-scale ejection seat test, in general, is characterized by extreme variability from test to test in the precise nature of the stresses imposed, particularly upon the extremities.

A worthwhile test of a meaningful injury criterion should also provide reasonable repeatability of results. In other words, for repetitions of the same imposed stress conditions, the test article and the model output using data from that article should have reasonable comparability from test to test. This is necessary in order to allow reasonable statistical confidence in the conclusions being sought through testing. Once again, subsystem testing allows better repeatability of stress, and therefore, better assessments of the repeatability of results. System testing provides the most direct means of attaining results relevant to the operational setting.

The proposed validation program, therefore, must be based upon a reasonable statistical experimental design incorporating subsystem tests, principally to assure reasonable repeatability for stresses and results with the maximum practical assessment of the relevance of stress as well. System tests, again based upon thoughtful statistical experimental design, would be used to extend the assessment of stress relevance and to achieve greater confidence in the relevance of the results.

PROPOSED VALIDATION PROGRAM

The validation program proposed in the future effort will be shaped considerably in its content by the choice of injury criteria to be evaluated. With the assumption that criteria chosen for evaluation may include a generalized head injury criterion along with bending injury criteria for proximal extremity long bones, the following is a general outline of a validation program currently envisioned.

Installed sensors in the ADAM manikin will first be evaluated through a series of subsystem tests based upon experimental test designs which have obtained data relevant to injury for a meaningful range of stress frequency characteristics. For example, an instrumented ADAM femur might be subjected to dynamic mechanical stresses similar to those experimentally imposed upon cadaver limbs to ensure that the test results could be used to reliably discriminate injurious from non-injurious stresses at the subsystem level. Similar approaches would be applied for subsystem testing of head impacts based upon experimental results with cadaver materials and scaled results from animal testing. Meaningful comparability should be demonstrated for the proposed criterion to the results attained in prior experimental testing of biological materials, both in terms of the form of the model output and the level. Should reasonable comparability not be demonstrated, adjustments to the model might be required either in form or in model parameter values in order to achieve the desired results. In addition, the ability of the instrumentation to produce acceptable results can also be demonstrated during this period using subsystem calibration tests for both static and time-varying stresses.

The next step would be to expose the instrumented ADAM to a sequence of system level tests in known subinjury threshold circumstances. Examples would be the duplication of whole body acceleration events previously demonstrated to be well-tolerated by human volunteer test subjects. These may include $+G_z$, $\pm G_x$, and $\pm G_y$ tests. Other tests for potential consideration would include retraction tests previously tolerated by human volunteers or similar tests producing stresses relevant to the chosen criteria, but at recognized subinjury levels. Injury criterion output from each of these tests should be consistent with a noninjurious outcome. Other more novel subthreshold system tests might be envisioned through the simulation of sports exposures. Such tests have been used by previous investigators who performed computations or occasionally made actual measurements of stresses being experienced by participants in certain kinds of athletic endeavors. Studies have been performed, for example, on cliff divers and boxers. For the ADAM subthreshold system level tests, it is proposed that a sequence of tests might be formulated in which the ADAM manikin served as a human surrogate in a simulated sports event. Subthreshold level head impacts might be envisioned using an ADAM manikin in conjunction with a live sparring partner. "Calibrated" blows might be delivered to the ADAM head in the form of jabs from a fighter wearing boxing gloves. Such an approach might be designed which would provide reasonable safety for the live fighter, since the probability of a return punch would be relatively low. Similar stresses might be envisioned for the extremities in a system level test in which an ADAM manikin would be used as a tackling dummy or similar surrogate. Here, the potential for knee ligament injury would be minimized by the design of the experiment, which would be configured to avoid the effect of a planted foot with a weight-bearing lower extremity at the time of impact from the tackler. For comparison to parachute landing fall settings, drop tests could be envisioned with some preflexion at the hips and knees.

For suprathreshold system level tests, a variety of approaches might be contemplated. The first of these would be controlled sled tests at levels which would be considered as suprathreshold from the standpoint of head injury. Other suprathreshold system level tests might include controlled pendulum impacts, freefall drop tests, and whole body impacts with torso, head or extremity flail envelopes designed to cause impact with structures in circumstances expected to be injurious.

With regard to the instrumented athletic simulations, the volunteer pugilist could be asked to deliver what he considered to be a bout-winning punch to the instrumented ADAM head. This, however, might pose some risk for the volunteer's upper extremity.

Suprathreshold systems tests directed toward the extremities might include controlled vehicular crash impacts at expected injury-producing levels, as well as calibrated drop tests. Attention would be required in the experimental design phases of these tests to ensure adequate observability in the range between known subthreshold and known suprathreshold. If these regions are defined too far apart from one another, an injury criterion might look good, when it in fact is not, based purely upon lack of resolution in the validation testing. This is expected to be more of a problem for the system level tests than for the subsystem level tests and the greatest confidence in defining the level for the various criteria will probably be gained in the subsystem level tests for that reason.

System level tests more relevant to the ejection scenario should be planned using three modalities. Ejection tower tests should define subthreshold levels for femur bending and for head injury. Windblast test facilities could be used both in a subthreshold and a suprathreshold sense by exposure to calibrated windstreams at various velocities with optimum or intentionally flailed extremity segments. Finally, full-scale ejection testing could also be accomplished under conditions in which reasonable expectations for avoidance of injury could be attained and, subsequently, in more severe conditions with intentionally malpositioned extremities where relevant injuries would be expected.

Clearly, the scale of the proposed validation program will be heavily driven by the choice of injury criteria to be validated and the desired confidence to be achieved in the validation program. For example, an approach to consider neck or upper arm injury might be considered to be of higher priority than the femur. Prior to the formulation of a follow-on effort, it would be desirable to arrive at some definition of the criteria to be pursued. Alternatively, a validation program could be pursued in a phased manner in which the first phase would accomplish the desired selection and program definition. Later efforts could be formulated to pursue a more comprehensive plan or to include considerations of injury criteria more directly related to automotive requirements or other circumstances having potential for broad societal benefit.

APPENDIX A - BIBLIOGRAPHY.

1. Aaras, A., Westgaard, R.H., Strandén, E. Postural Angles as an Indicator of Postural Load and Muscular Injury in Occupational Work Situations. *Ergonomics*, 31, 915-933 (June 1988).
2. The Abbreviated Injury Scale, 1990 Revision. Des Plaines, IL, Association for the Advancement of Automotive Medicine, (1990).
3. Abel, J.M., Gennarelli, T.A., Segawa, H. Incidence and Severity of Cerebral Concussion in the Rhesus Monkey Following Sagittal Plane Angular Acceleration. **Proceedings of the 22nd Stapp Car Crash Conference, Ann Arbor, MI, October 24-26, 1978. Society of Automotive Engineers Proceedings No. P-77, Warrendale, PA, Society of Automotive Engineers, 35-53 (1978).**
4. Abrams, T.S., Kaleps, I., Brinkley, J.W. The Armstrong Aerospace Medical Research Laboratory (AAMRL) Biodynamics Data Bank. TR-88-037, December 1988.
5. Adams, W.E. Traumatism of the Thorax. *Adv Cardiopulm Dis*, 4, 208-24 (1969).
6. Adeyemo, A.O., Arigbabu, A.O., Adejuyigbe, O. Thoracic Injuries in Road Traffic Accidents: Analysis of 148 Cases. *Injury*, 16, 30-4 (July 1984).
7. Advani, S.H., Huston, J., Powell, W.R., Cook, W. Human Head and Neck Dynamic Response: Analytical Models and Experimental Data. *Aircraft Crashworthiness (Proceedings of a Symposium, Cincinnati, OH, October 6-8, 1975)*. Saczalski, Kenneth, Singley, George T. 3d, Pilkey, Walter D. And Huston, Ronald L., eds. Charlottesville, VA, University Press of Virginia, 197-212 (1975).
8. Advani, S.H., McClung, H.B. Asymmetric Response of an Elastic Sphere: a Rotational Head Injury Model. *Adv Bioengineering* 73-75 (1974).
9. Advani, S.H., Owings, R., Shuck, L.Z. Dynamic Response Evaluation of Translational and Rotational Head Injury Models. *Shock Vibrat Digest*, 4, 3-16 (1972).
10. Advani, S.H., Owings, R.P. Evaluation of Head Injury Criteria. Presented at Automotive Engineering Congress, Detroit, MI, February 25-March 1, 1974. Society of Automotive Engineers Technical Paper No. 740083. New York, NY, Society of Automotive Engineers, 1-11 (1974).
11. Advani, S.H., Owings, R.P. Structural Modeling of Human Head. *Am Soc Civil Eng, J Eng Mech Div*, 101, 257-66 (June 1975).

12. **Aircrew Automated Escape Systems (AAES). In-Service Usage Data Analyses, Volume 1. Papers. Presented at the 21st Annual Survival and Flight Equipment Association Symposium held on November 5, 6, 7, 8, 1983 in San Antonio, Texas. NAVWESA-1-83-Vol 1.**
13. **Aircrew Automated Escape Systems (AAES), Volume 1. In-Service Usage Data Analyses Program Symposium held on October 6, 7, 8, 1981 at Norfolk, VA, Naval Air Systems Command, Naval Safety Center, 1981.**
14. **Aircrew Automated Escape Systems (AAES), Volume 2. In-Service Usage Data Analyses Program Symposium held on October 6, 7, 8, 1981 at Norfolk, VA, Naval Air Systems Command, Naval Safety Center, 1981.**
15. **Aircrew Automated Escape Systems (AAES), Volume 3. In-Service Usage Data Analyses Program Symposium held on October 6, 7, 8, 1981 at Norfolk, VA, Naval Air Systems Command, Naval Safety Center, 1981.**
16. **Aircrew Automated Escape Systems (AAES), Volume 4. In-Service Usage Data Analyses Program Symposium held on October 6, 7, 8, 1981 at Norfolk, VA, Naval Air Systems Command, Naval Safety Center, 1981.**
17. **Aircrew Automated Escape Systems (AAES). In-Service Usage Data Analysis Program. Papers. Presented at the 17th Annual Fallsafe meeting held on February 8-12, 1982 in Corpus Christi, TX, Naval Regional Medical Center, 1982.**
18. **Akkas, N. The Effect of Pulse Duration on Head Injury. Am Soc Civil Eng, J Eng Mech Div, 103, 35-49 (February 1977).**
19. **Albright, J.P., McAuley, E., Martin, R.K., Crowley, E.T., Foster, D.T. Head and Neck Injuries in College Football: An Eight-year Analysis. Am J Sports Med, 13, 147-52 (May-June 1985).**
20. **Aldman, B., Kajzer, J., Cesari, D., Bouquet, R., Zac, R. A New Dummy for Pedestrian Test. Proceedings of the 10th International Technical Conference on Experimental Safety Vehicles, Oxford, England, July 1-4, 1985. Washington, D.C., U.S. Department of Transportation, National Highway Traffic Safety Administration, 176-85 (1985).**
21. **Aldman, B., Ljung, C., Thorngren, L. Intracranial Deformation Patterns Due to Impulsive Loading: a Model Study. Proceedings of the 9th International Technical Conference on Experimental Safety Vehicles, Kyoto, Japan, November 1-4, 1982. Washington, D.C., U.S. Department of Transportation, National Highway Traffic Safety Administration, 269-74 (1982).**

22. Aldman, B., Thorngreen, L., Bunketorp, O., Romanus, B. An Experimental Model System for the Study of Lower Leg and Knee Injuries in Car-Pedestrian Accidents. Proceedings of the 8th International Technical Conference on Experimental Safety Vehicles, Wolfsburg, West Germany, October 21-24, 1980. Washington, D.C., U.S. Department of Transportation, National Highway Traffic Safety Administration, 841-9 (1980).
23. **Alem, N.M. Simulation of Head Injury Due to Combined Rotation and Translation of the Brain. Proceedings of the 18th Stapp Car Crash Conference, Ann Arbor, MI, December 4-5, 1974, (Society of Automotive Engineers Proceedings No. P-56). Warrendale, PA, Society of Automotive Engineers, 579-98 (1974).**
24. Alem, N.M. Whole Body Response Research Program. Appendix C: Processed Data. Ann Arbor, MI, University of Michigan, Highway Safety Research Institute. UM-HSRI-77-39-4, April 25, 1978.
25. Alem, N.M., Benson, J.B., Holstein, G.L., Melvin, J.W. Whole Body Response Research Program. Ann Arbor, MI, University of Michigan, Highway Safety Research Institute, Appendix A: Methodology. UM-HSRI-77-39-2, April 25, 1978.
26. Alem, N.M., Benson, J.B., Tann, T.A. Whole Body Response Research Program. Appendix B: Raw Data. Ann Arbor, MI, University of Michigan, Highway Safety Research Institute, UM-HSRI-77-39-3, April 25, 1978.
27. Alem, N.M., Benson, J.B., Melvin, J.W. Whole Body Response of the Hybrid III Anthropomorphic Test Device. Ann Arbor, MI, University of Michigan, Highway Safety Research Institute, UM-HSRI-77-10, February 28, 1977.
28. Alem, N.M., Bowman, B.M., Melvin, J.W., Benson, J.B. Whole-Body Human Surrogate Response to Three-Point Harness Restraint. Proceedings of the 22nd Stapp Car Crash Conference, Ann Arbor, MI, October 24-26, 1978, (Society of Automotive Engineers Proceedings No. P-77). Warrendale, PA, Society of Automotive Engineers, 361-99 (1978).
29. Alem, N.M., Melvin, J.W., Bowman, B.M., Benson, J.B. Whole Body Response Research Program. Ann Arbor, MI, University of Michigan, Highway Safety Research Institute. UI-77-39-1, April 25, 1978.
30. Alem, N.M., Nusholtz, G.S., Melvin, J.W. Head and neck response to axial impacts. Proceedings of the 28th Stapp Car Crash Conference, Chicago, IL, November 6-7, 1984, (Society of Automotive Engineers Proceedings No. P-152). Warrendale, PA, Society of Automotive Engineers, 275-88 (1984).

31. Alem, N.M., Nusholtz, G.S., Melvin, J.W. Superior-Inferior Head Impact Tolerance Levels. Ann Arbor, MI, University of Michigan, Transportation Research Institute. UMTRI-82-42, November 1982.
32. Alfaro-Bou, E., Fasanella, E.L., Williams, M.S. Crashworthy Design Considerations for General Aviation Seats, (Society of Automotive Engineers Technical Paper No. 850885). Warrendale, PA, Society of Automotive Engineers, 65-78 (1985).
33. Alker, G.J. Jr., Oh, Y.S., Leslie, E.V. High Cervical Spine and Craniocervical Junction Injuries in Fatal Traffic Accidents: a Radiological Study. Orthop Clin North Am, 9, 1003-10 (Oct 1978).
34. Allen, L.J. Finite Element Analysis of the Visco-elastic Interaction of the Annulus Fibrosis and Nucleus Pulposus within the Human Intervertebral Joint [M.S. Thesis]. AFIT/GAE/AA/81D-1, December 1981.
35. Allsop, D.L., Warner, C.Y., Wille, M.G., Schneider, D.C., Nahum, A.M. Facial Impact Response: a Comparison of the Hybrid III Dummy and Human Cadaver. Proceedings of the 32nd Stapp Car Crash Conference, Atlanta, GA, October 17-19, 1988, (Society of Automotive Engineers Proceedings No. P-215). Warrendale, PA, Society of Automotive Engineers, 139-55 (1988).
36. Althoff, B. Fracture of the Odontoid Process. An Experimental and Clinical Study. Acta Orthop Scand Suppl, 177, 1-95 (1979).
37. Analytical Study of Traumatic Lesions of C3-C7. IN: Physiopathology and Pathology of Spinal Injuries in Aerospace Medicine, Neuilly-sur-Seine, France, Advisory Group for Aerospace Research and Development, AGARD-AG-250(ENG)-2ND, 187-198 (February 1982).
38. Andrac, B.O., Ek, E., Lorin, H., Stroemblad, B.C.R. High Speed Ejections with SAAB Seats. IN: Biodynamic Response to Windblast. Neuilly-sur-Seine, France, Advisory Group for Aerospace Research and Development. AGARD-CP-170, July 1975.
39. Anton, D.J. The Biodynamic Implications of Helmet Mounted Devices. Proceedings of a Symposium on Aircrew Helmets and Helmet Mounted Devices, London, England, February 10, 1987. London, Royal Aeronautical Society, 15.1-15.13 (1987).
40. Anton, D.J. Introduction: The Clinical and Biomedical Evaluation of Trauma and Fatalities Associated with Aircraft Ejection and Crash. Neuilly-sur-Seine, France, Advisory Group for Aerospace Research and Development. AGARD-AR-194, December 1984.

41. **Anton, D.J. A Review of Fatality, Impairment of Consciousness, and Head and Neck Injury on Royal Air Force Ejections 1968-1981. Neuilly-sur-Seine, France, Advisory Group for Aerospace Research and Development. AGARD-AR-194, 22-33 (December 1984).**
42. **Arajarvi, E. A Retrospective Analysis of Chest Injuries in 280 Seat Belt Wearers. Accid Anal Prev, 20(4), 251-9 (1988 Aug).**
43. **Arendt, R., Segal, D., Cheng, R. Review of Anthropomorphic Test Device Instrumentation, Data Processing and Certification Test Procedures. Washington, D.C., U.S. Department of Transportation, National Highway Traffic Safety Administration. UMTRI-84-41, December 1984.**
44. **Arndt, R. Work Pace, Stress, and Cumulative Trauma Disorders. J Hand Surg [Am], 12(5 Pt 2), 866-9 (1987 Sep).**
45. **Arthornthurasook, A. Trochanteric Fracture. J Med Assoc Thai, 65(12), 629-33 (1982 Dec).**
46. **Asang, E. Experimental Biomechanics of the Human Leg. A Basis for Interpreting Typical Skiing Injury Mechanisms. Orthop Clin North Am, 7(1), 63-73 (1976 Jan).**
47. **Auffret, R., Delahaye, R.P. Spinal Injury After Ejection. Neuilly-sur-Seine, France, Advisory Group for Aerospace Research and Development. AGARD-AR-72, February 1975.**
48. **Auffret, R., Delahaye, R.P. Spinal Injury After Ejection [Statistical Analysis]. Washington, D.C, National Aeronautics and Space Administration. NASA-TT-F-15,702, 1974. (Translated into English from the French Report).**
49. **Avula, X.J., Oestreicher, H.L. Mathematical Model of the Cardiovascular System Under Acceleration Stress. Aviat Space Environ Med, 49(1), 279-286 (1978 Jan).**
50. **Backaitis, S.H., St-Laurent, A. Chest Deflection Characteristics of Volunteers and Hybrid III Dummies. Proceedings of the 30th Stapp Car Crash Conference, San Diego, CA, October 27-29, 1986, (Society of Automotive Engineers Proceedings No. P-189). Warrendale, PA, Society of Automotive Engineers, 157-66 (1986).**
51. **Baker, S.P., O'Neill, B., Haddon, W., Long, W.B. The Injury Severity Score: A Method for Describing Patients with Multiple Injuries and Evaluating Emergency Care. J Trauma, 14, 187-196 (1974).**

52. **Ballo, J.M., Dunne, M.J. Jr., McMeekin, R.R. Validation of the CALSPAN Gross-motion-simulation Code with Actually Occurring Injury Patterns in Aircraft Accidents. Aviat Space Environ Med, 49(1, Sect.II), 191-195 (1978 Jan).**
53. **Barash, I.M. The Etiology and Prophylaxis of Vertebral Fracture in Crash Landings. Biodynamics Data Bank, Wright-Patterson AFB, OH.**
54. **Barer, A.S., Konakhevich, Y.G., Sholpo, L.N., Kurme, D.A., Leytene, L.Y. Differential Criterion for Tolerance of a Blow to the Head in Certification of Protective Gear. In Its JPRS Report: Science and Technology. USSR: Life Sciences P 3. Translated into English from Komischeskaya Biologiya I Aviakosmicheskaya Meditsina, 23(4), 76-79, (1989 Jul/Aug). [ABSTRACT ONLY].**
55. **Barrie, H.J., Hodson-Walker, N. Incidence and Pathogenesis of Fractures of the Lumbar Transverse Processes in Air Crashes. Aerosp Med, 1970 Jul, 41(7), 805-8.**
56. **Bartol, A.M., Hazen, V.L., Kowalski, J.F., Murphy, B.P., White, R.P. Jr. Advanced Dynamic Anthropomorphic Manikin (ADAM). Final Design Report. AAMRL-TR-90 -23, March 1990.**
57. **Bartol, A.M., Kaleps, I. The Development of Segment-based Axis Systems for the Air Force Advanced Dynamic Anthropomorphic Manikin (ADAM). Proceedings of the 11th International Technical Conference On Experimental Safety Vehicles, Washington, D.C., May 12-15, 1987. Washington, D.C., U.S. Department of Transportation, National Highway Traffic Safety Administration, 346-62 (1987).**
58. **Barwood, A.J. Problems of Ejection from Aircraft. Sources of Ejection Injury. Proc R Soc Med, 68(11), 721-2 (1975 Nov).**
59. **Bauer, R.D., Errico, T.J., Waugh, T.R., Cohen, W. Evaluation and Diagnosis of Cervical Spine Injuries: a Review of the Literature. Cent Nerv Syst Trauma, 4(2), 71-93 (1987).**
60. **Bauze, R.J., Ardran, G.M. Experimental Production of Forward Dislocation in the Human Cervical Spine. J Bone Joint Surg [Br.], 60B, 239-45 (1978).**
61. **Bayless, P., Ray, V.G. Incidence of Cervical Spine Injuries in Association with Blunt Head Trauma. Am J Emerg Med, 7(2), 139-42 (1989 Mar).**
62. **Beck, A. The Risk of Minor Spinal Abnormalities in Aircrews: Evaluation of Ejection Cases. IN: Pathophysiologic Conditions Compatible with Flying. Neuilly-sur-Seine, France, Advisory Group On Aerospace Research and Development, B10.1-B10.4, October 1973.**

63. **Becker, E.; Willems, G. An Experimentally Validated 3-D Inertial Tracking Package for Application in Biodynamic Research. Proceedings of the 19th Stapp Car Crash Conference. San Diego, CA, November 17-19, 1975, (Society of Automotive Engineers Proceedings No. P-62). Warrendale, PA, Society of Automotive Engineers, 899-930, (1975).**
64. **Becker, J.A. Ejection Injuries in the German Air Force (1957-1970). Class 72A, Advanced Aerospace Medicine for Allied Medical Officers, Brooks AFB TX. Biodynamics Data Bank, Wright-Patterson AFB, OH, June 1972.**
65. **Beebe, M.S. Biosid Update and Calibration Requirements. Proceedings of the International Congress and Exposition, Detroit, MI, February 25-March 1, 1991, (Society of Automotive Engineers Technical Paper No. 910319). Warrendale, PA, Society of Automotive Engineers, 1-8 (1991).**
66. **Beebe, M.S. What Is Biosid? Proceedings of the International Congress and Exhibition, Detroit, MI, February 26-March 2, 1990, (Society of Automotive Engineers Technical Paper No. 900377). Warrendale, PA. Society of Automotive Engineers, 1-14, (1990).**
67. **Begeman, P.C., King, A.I., Prasad, P. Spinal Loads Resulting from -Gx Acceleration. Proceedings of the 17th Stapp Car Crash Conference, Oklahoma City, OK, November 12-13, 1973, (Society of Automotive Engineers Proceedings No. P-51). Warrendale, PA, Society of Automotive Engineers, 343-60 (1973).**
68. **Begeman, P.C., Prasad, P. Human Ankle Impact Response in Dorsiflexion. Proceedings of the 34th Stapp Car Crash Conference, Orlando, FL, November 4-7, 1990, (Society of Automotive Engineers Proceedings No. P-236). Warrendale, PA, Society of Automotive Engineers, 39-53 (1990).**
69. **Belk, W.F. Limb Flail Injuries and the Effect of Extremity Restraints in USAF Ejections—1971-1978. SAFE J, 10, 18-21 (1980 Summer).**
70. **Belytschko, T., Privitzer, E., Mindle, W., Wicks, T. Computer Simulation of Canopy-Pilot Response to Bird-Strike. AMRL-TR-79-20, October 1979.**
71. **Belytschko, T., Privitzer, E. Refinement and Validation of a Three-Dimensional Head-Spine Model. AMRL-TR-78-7, August 1978.**
72. **Belytschko, T., Rencis, M., Williams, J. Head-Spine Structure Modeling: Enhancements to Secondary Loading Path Model and Validation of Head-Cervical Spine Model. AAMRL-TR-85-019, July 1985.**

73. **Belytschko, T., Schwer, L., Prvizter, E. Theory and Application of a Three-Dimensional Model of the Human Spine. Aviat Space Environ Med 1978 January, 49 (1 Pt. 2), 158-65.**
74. **Belytschko, T., Schwer, L., Schultz, A. A Model for Analytic Investigation of Three-Dimensional Head-Spine Dynamics. AMRL-TR-76-10, April 1976.**
75. **Bendjellal, F., Gillet, D., Foret-Bruno, J.Y., Tarriere, C. Measurement of Seat-belt Loads Sustained by the Dummy in Frontal Impact with Critical Pelvic Motion: Development of a 2-D Transducer. Proceedings of the 12th International Technical Conference on Experimental Safety Vehicles, Goteborg, Sweden, May 29-June 1, 1989. Washington, D.C., U.S. Department of Transportation, National Highway Traffic Safety Administration, 673-83 (1989).**
76. **Bendjellal, F., Tarriere, C., Brun-Cassan, F., Foret-Bruno, J.Y., Caillibot, P., Gillet, D. Comparative Evaluation of the Biofidelity of EUROSID and SID Side Impact Dummies. Proceedings of the 32nd Stapp Car Crash Conference, Atlanta, GA, October 17-19, 1988, (Society of Automotive Engineers Proceedings No. P-215). Warrendale, PA, Society of Automotive Engineers, 237-78 (1988).**
77. **Bendjellal, F., Tarriere, C., Gillet, D., Mack, P., Guillon, F. Head and Neck Responses Under High G-level Lateral Deceleration. Proceedings of the 31st Stapp Car Crash Conference, New Orleans, LA, November 9-11, 1987, (Society of Automotive Engineers Proceedings No. P-202). Warrendale, PA, Society of Automotive Engineers, (1987).**
78. **Benedict, J.V. The Investigation of Vertebral Injury Sustained During Aircrew Ejection. Annual Technical Report, June 28, 1970 - January 15, 1972. San Antonio, TX, Technology Incorporated, 1972.**
79. **Benedict, J.V. Use of a Mathematical Model for the Evaluation of Head Injury Criteria. AMRL-TR-71-29, Paper No. 4, December 1971.**
80. **Benedict, J.V., Harris, E.H., Von Roseberg, D.U. An Analytical Investigation of the Cavitation Hypothesis of Brain Damage. J Basic Eng, Trans ASME, 92, 597-603 (1970).**
81. **Bengner, U., Ekbohm, T., Johnell, O., Nilsson, B.E. Incidence of Femoral and Tibial Shaft Fractures. Epidemiology 1950-1983 in Malmo, Sweden. Acta Orthop Scand, 61(3), 251-4 (1970).**
82. **Berger, M.D., Weiss, M.S. Effects of Impact Acceleration On Somatosensory Evoked Potentials. NBDL-83R002, April 1983.**

83. Berger, R.E., Calvano, N.J. Procedure for Selecting Parameters for Testing Headgear Safety. Presented at a Symposium On Advances in Bioengineering at the Annual Winter Meeting of the American Society of Mechanical Engineers, San Francisco, CA, December 10- 15, 1978. New York, NY, American Society of Mechanical Engineers, 45-47 (1978).
84. **Biodynamic Models and Their Applications. Proceedings of the 2nd Symposium, Dayton, OH, February 15-17, 1977. Aviat Space Environ Med, 49 (Sect. II), 1-243 (1978 Jan).**
85. Bishop, P.J., Norman, R.W., Wells, R., Ranney, D., Skleryk, B. Changes in the Centre of Mass and Moment of Inertia of a Headform Induced by a Hockey Helmet and Face Shield. *Can J Appl Sport Sci*, 8(1), 19-25 (1983 Mar).
86. Bishop, P.J., Wells, R.P. A Computer Simulation Model for Studying Cervical Spine Injury Prevention. IN: Neck Injury in Advanced Military Aircraft Environments, Neuilly-sur-Seine, France, Advisory Group for Aerospace Research and Development AGARD-CP-471, 18-1-18-5 (February 1990).
87. Blaker, J.L. Evaluation Tests of Lower Neck Transducer for the Hybrid III Dummy. Final Report January-August 1987. Washington, D C., U.S. Department of Transportation, National Highway Traffic Safety Administration, DOT-HS-807-178, August 1987.
88. Blaker, J.L. User's Guide—Lower Neck Transducer for the Hybrid III Dummy. Final Report January-August 1987. Washington, D.C., U.S. Department of Transportation, National Highway Traffic Safety Administration, August 1987.
89. Boehly, W.A., Kianiantra, J.N. Feasibility of Relating Laboratory Injury Measures in Simulated Accidents to Real-world Occurrences in Side Impacts. Proceedings of the 9th International Technical Conference On Experimental Safety Vehicles, Kyoto, Japan, November 1-4, 1982. Washington, D.C., U.S. Department of Transportation, National Highway Traffic Safety Administration, 621-9 (1982).
90. Bohlman, H.H. Acute Fractures and Dislocations of the Cervical Spine. An Analysis of Three Hundred Hospitalized Patients and Review of the Literature. *J Bone Joint Surg [Am]*, 61(8), 1119-42 (1979 Dec).
91. **Bonner, R.H. Role of Helmet Loss in Head Injuries to USAF Aircrews Who Ejected, 1963-1967. *Aerosp Med*, 40(10), 1123-5 (1969 Oct).**
92. Bourne, R.B. Pylon Fractures of the Distal Tibia. *Clin Orthop*, (240), 42-6 (1989 Mar).

93. **Bowman, B.M., Schneider, L.W., Lustick, L.S., Anderson, W.R., Thomas, D.J. Simulation Analysis of Head and Neck Dynamic Response. Proceedings of the 28th Stapp Car Crash Conference, Chicago, IL, November 6-7, 1984, (Society of Automotive Engineers Proceedings No. P-152). Warrendale, PA, Society of Automotive Engineers, 173-205 (1984).**
94. **Bowman, B.M., Schneider, L.W., Rohr, P.R., Mohan, D. Simulation of Head/neck Impact Responses for Helmeted and Unhelmeted Motorcyclists. Proceedings of the 25th Stapp Car Crash Conference, San Francisco, CA, September 28-30, 1981, (Society of Automotive Engineers Proceedings No. P-97). Warrendale, PA, Society of Automotive Engineers, 13-68 (1981).**
95. **Bowman, B.M., Schneider, L.W., Foust, D.R. Simulated Occupant Response to Side-impact Collisions. Proceedings of the 19th Stapp Car Crash Conference, San Diego, CA, November 17-19, 1975, (Society of Automotive Engineers Proceedings No. P-62). Warrendale, PA, Society of Automotive Engineers, 429-54 (1975).**
96. **Bozack, T.J., Doerr, J.E. System to Measure Head Motion During Parachute Opening Shock. Presented at the 1st AIAA, SETP, SFTE, SAE, ITEA and IEEE Flight Testing Conference, Las Vegas, NV, November 11-13, 1981. Washington, D C., American Institute of Aeronautics and Astronautics, 1-9 (1981).**
97. **Brinkley, J.W. Acceleration Exposure Limits for Escape System Advanced Development. SAFE J, 15, 10-16 (1985 Summer).**
98. **Brinkley, J.W. Review of the Operational Efficacy of USAF Flight Helmets in Crash and Escape Environments. AMRL-TR-75-74, August 1975.**
99. **Brinkley, J.W., Dearing, E.R. Evaluation of the Effects of Selected Egress System Design Parameters During +Gz Acceleration. AMRL-TR-69-51, May 1969.**
100. **Brinkley, J.W., Payne, P.R. An Assessment of Aerodynamic Forces Acting On the Crewman During Escape. IN: Escape Problems and Manoeuvres in Combat Aircraft. Neuilly-sur-Seine, France, Advisory Group for Aerospace Research and Development. AGARD-CP-134, A4-1-A4-10 (February 1974).**
101. **Brinkley, J.W., Payne, P.R. A Study of Aerodynamic Forces as a Cause of Injury During Emergency Escape. AMRL-TR-73-55, May 1973.**
102. **Brinkley, J.W., Raddin, J.H. Jr. IN: Biodynamics: Transitory Acceleration. Fundamentals of Aerospace Medicine. Boston, MA, Lea and Febiger, Publishers, 1985.**

103. **Brinkley, J.W., Raddin, J.H. Jr., Hearon, B.F., McGowan, L.A., Powers, J.M. Evaluation of a Proposed, Modified F/FB-111 Crew Seat and Restraint System. AFAMRL-TR-80-52, November 1981.**
104. Brinkley, J.W., Shaffer, J.T. Dynamic Simulation Techniques for the Design of Escape Systems: Current Applications and Future Air Force Requirements. IN: Biodynamic Models and Their Applications. Aerospace Medical Research Laboratory, Wright-Patterson Air Force Base, OH. AMRL-TR-71-29-2, (1971).
105. **Brinkley, J.W., Specker, L.J., Mosher, S.E. Development of Acceleration Exposure Limits for Advanced Escape Systems. IN: Implications for Advanced Technologies for Air and Spacecraft Escape. Neuilly-sur-Seine, France, Advisory Group for Aerospace Research and Development, AGARD-CP-472, 1-1-1-14 (1990).**
106. Brinn, J., Staffeld, S.E. The Effective Displacement Index—An Analysis Technique for Crash Impacts of Anthropometric Dummies. Proceedings of the 15th Stapp Car Crash Conference, Coronado, CA, November 17-19, 1971, (Society of Automotive Engineers Proceedings No. P-39). New York, NY, Society of Automotive Engineers, 742-66 (1971).
107. Briscoe, C.H. Thoracolumbar Fractures. S Afr Med J, 70(6), 321-4 (1986 Sep 13).
108. Brockway, J.A., Brown, H.E., Higgins, L.S., Howard, R.H., Schmall, R.A. The Investigation of Vertebral Injury Sustained During Aircrew Ejection. Phase 2a—Basic Science Experimental Design and Investigation of Dynamic Characteristics of Vertebral Columns. San Antonio, TX, Technology, Inc., NASA-CR-92541, October 1967.
109. Brooks, C.J., Rowe, K.W. Water Survival: 20 Years Canadian Forces Aircrew Experience. Aviat Space Environ Med, 55(1), 41-51 (1984 Jan).
110. Brubaker, W., Tomassoni, J. Some Special Analyses of Thoracic Protection in Side Impact. Presented at the International Congress & Exposition, Detroit, MI, February 28-March 4, 1983, (Society of Automotive Engineers Technical Paper No. 830466). Warrendale, PA, Society of Automotive Engineers, 1-10 (1983).
111. Brumback, R.J., Kenzora, J.E., Levitt, L.E., Burgess, A.R., Poka, A. Fractures of the Femoral Head. Hip, 181-206 (1987).
112. Brun-Cassar, F., Pincemaille, Y., Mack, P., Tarriere, C. Contribution and Evaluation of Criteria Proposed for Thorax- Abdomen Protection in Lateral Impact. Proceedings of the 11th International Technical Conference On Experimental Safety Vehicles, Washington, D.C., May 12-15, 1987. Washington, D.C., U.S. Department of Transportation, National Highway Traffic Safety Administration, 289-301 (1987).

113. Brun-Cassan, F., Pincemaille, Y., Fayon, A., Tarriere, C. Influence of the Type of Thoracic Protection Criteria Used in Side Impacts On the Choice of Thorax Model and Interior Fittings. Presented at the Government/Industry Meeting & Exposition, Washington, D.C., May 21-24, 1984, (Society of Automotive Engineers Technical Paper No. 840881). Warrendale, PA, Society of Automotive Engineers, 1-11 (1984).
114. Bucholz, R.W., Burkhead, W.Z., Graham, W., Petty, C. Occult Cervical Spine Injuries in Fatal Traffic Accidents. *J Trauma*, 19(10), 768-771 (1979 Oct).
115. Bull, J.O., Ther, D.T., Yurczyk, R.F. Advanced Ejection Seat for High Dynamic Pressure Escape. Wind Tunnel Test Report. TR-80-3084, August 1980.
116. Burns, K.C., Smith, D.E. Statistical Impact Acceleration Injury Prediction Models Based On -Gx Accelerator Data and Initial Head Conditions. TR-112-13, May 1983.
117. Burow, K., Kramer, M. Experimentelle Untersuchungen uber die Art und Schwere von Frakturen am Brustkorb [Experimental Research on the Type and Severity of Chest Fractures]. Proceedings of the International Conference On the Biokinetics of Impacts, Amsterdam, Netherlands, 387-397 (1973). [In German].
118. Bury, R.F. Bone Scintigraphy in the Evaluation of Ejection Injuries. *Aviat Space Environ Med*, 60(7 Pt 2), A16-7 (1989 Jul).
119. Buschman, D.L., Rittgers, S.E. Injuries Induced by High Speed Ejection—An Analysis of USAF Noncombat Operational Experience. Proceedings of the 10th Annual Symposium of the Survival and Flight Equipment Association, Phoenix, AZ, October 2-5, 1972 (SAFE). SAFE Association, Canoga Park, CA, 63-66 (1972).
120. Bycroft, G.N. Mathematical Model of a Head Subjected to an Angular Acceleration. *J Biomech*, 6(5), 487-495 (1973).
121. Calandra, J.J., Baker, C.L., Uribe, J. The Incidence of Hill-Sachs Lesions in Initial Anterior Shoulder Dislocations. *Arthroscopy*, 5(4), 254-7 (1989).
122. Cambeis, L. Bibliography of Impact Acceleration Literature. Annex to Synthesis of Impact Acceleration Technology for Aviation Crash Injury Prevention (Project SIAT). Task 1A024701A12101, June 1963.
123. Campbell, K.L., Wasko, R.J., Henson, S.E. Analysis of Side Impact Test Data Comparing SID and BIOSID. Proceedings of the 34th Stapp Car Crash Conference, Orlando, FL, November 4-7, 1990, (Society of Automotive Engineers Proceedings No. P-236). Warrendale, PA, Society of Automotive Engineers, 185-205 (1990).

124. Careme, L.M. Biomechanics of Head Injury in Frontal Impacts. IN: **Vehicle Crashworthiness and Occupant Protection in Frontal Impacts**, (Society of Automotive Engineers Proceedings No. SP-807). Warrendale, PA, Society of Automotive Engineers, 93-102 (1990).
125. Careme, L.M. Biomechanical Tolerance Limits of the Cranio-cervical Junction in Side Impacts. IN: **Side Impact: Injury Causation and Occupant Protection**, (Society of Automotive Engineers Proceedings No. SP-769). Warrendale, PA, Society of Automotive Engineers, 55-60 (1989).
126. Carsten, O., O'Day, J. Injury Priority Analysis. Washington, D.C., U.S. Department of Transportation, National Highway Traffic Safety Administration. UMTRI-82-24, October 1984.
127. Carter, D.R., Frankel, V.H. Biomechanics of Hyperextension Injuries to the Cervical Spine in Football. *Am J Sports Med*, 8(5), 302-9 (1980 Sep-Oct).
128. Cavanaugh, J.M., Walilko, T.J., Malhotra, A., Zhu, Y., King, A.I. Biomechanical Response and Injury Tolerance of the Thorax in Twelve Sled Side Impacts. Proceedings of the 34th Stapp Car Crash Conference, Orlando, FL, November 4-7, 1990, (Society of Automotive Engineers Proceedings No. P-236). Warrendale, PA, Society of Automotive Engineers, 23-38 (1990).
129. Caveness, W.F., Ed. **Head Injury**. Philadelphia, PA: J.B. Lippincott, 1966.
130. Cesari, D., Bouquet, R. Behaviour of Human Surrogates Thorax Under Belt Loading. Proceedings of the 34th Stapp Car Crash Conference, Orlando, FL, November 4-7, 1990, (Society of Automotive Engineers Proceedings No. P-236). Warrendale, PA, Society of Automotive Engineers, 73-81 (1990).
131. Cesari, D., Bouquet, R., Zac, R. Improvements of EUROSID Pelvis Biofidelity. IN: **Side Impact: Injury Causation and Occupant Protection**, (Society of Automotive Engineers Proceedings No. SP-769). Warrendale, PA, Society of Automotive Engineers, 173-7 (1989).
132. Cesari, D., Cavallero, C., Roche, H. Evaluation of the Round Symmetrical Pedestrian Dummy Leg Behaviour. Proceedings of the 12th International Technical Conference On Experimental Safety Vehicles, Goteborg, Sweden, May 29-June 1, 1989. Washington, D.C., U.S. Department of Transportation, National Highway Traffic Safety Administration, 1244-6 (1989).

133. **Cesari, D., Ramet, M. Comparison Between In-the-field Accidents and Reconstructed Accidents with Dummies and with Cadavers. Proceedings of the 19th Stapp Car Crash Conference, San Diego, CA, November 17-19, 1975, (Society of Automotive Engineers Proceedings No. P-62). Warrendale, PA, Society of Automotive Engineers, 167-93 (1975).**
134. **Cesari, D., Ramet, M. Etat De La Question Sur Les Tolerances Du Segment Thoracique [State-of-the-Art On Thoracic Tolerances]. Proceedings of the International Conference On the Biokinetics of Impacts (IRCOBI), 367-386 (1973). [In French].**
135. **Cesari, D., Ramet, M., Clair, P.Y. Evaluation of Pelvic Fracture Tolerance in Side Impact. Proceedings of the 24th Stapp Car Crash Conference, Troy, MI, October 15-17, 1980, (Society of Automotive Engineers Proceedings No. P-88). Warrendale, PA, Society of Automotive Engineers, 231-53 (1980).**
136. **Cesari, D., Ramet, M. Evaluation of Human Tolerance in Frontal Impacts. Proceedings of the 23rd Stapp Car Crash Conference, San Diego, CA, October 17-19, 1979, (Society of Automotive Engineers Proceedings No. P-82). Warrendale, PA, Society of Automotive Engineers, 875-914 (1979).**
137. **Cesari, D., Ramet, M., Bloch, J. Influence of Arm Position On Thoracic Injuries in Side Impact. Proceedings of the 25th Stapp Car Crash Conference, San Francisco, September 28-30, 1981, (Society of Automotive Engineers Proceedings No. P-97). Warrendale, PA, Society of Automotive Engineers, 271-97 (1981).**
138. **Chaffin, D.B. Some Advantages and Limitations of Macro Static Models for Determining Spinal Injury Potential During Weight Liftings. Proceedings of a National Science Foundation Workshop On Volitional Biomechanics, University of Florida, April 14-15, 1975.**
139. **Chamouard, F., Tarriere, C., Got, C., Guillon, F., Patel, A., Hureau, J. Relationship Between Some Biomechanical and Dimensional Characteristics of the Skull and the Risk of Cerebral Injuries. AAAM Q J, 1986 Oct, 8(4), 11-23.**
140. **Chandler, R.F. Human Injury Criteria Relative to Civil Aircraft Seat and Restraint Systems. Presented at the Aerospace Technology Conference & Exposition, Long Beach, CA, October 14-17, 1985, (Society of Automotive Engineers Technical Paper No. 851847). Warrendale, PA, Society of Automotive Engineers, 1-10 (1985).**
141. **Chen, P.H. Finite Element Dynamic Structural Model of the Human Thorax for Chest Impact Response and Injury Studies. Aviat Space Environ Med 1978 Jan, 49(1), 143-149.**
142. **Chen, S.J. A Mechanical Model of the Human Ligamentous Spine and Its Application to the Pilot Ejection Problem [Ph.D. Thesis]. Iowa City, IA, Iowa University, 1973.**

143. Cheng, R., Denton, R.A., King, A.I. Femoral Loads Measured by a Six-axis Load Cell. Proceedings of the 23rd Stapp Car Crash Conference, San Diego, CA, October 17-19, 1979, (Society of Automotive Engineers Proceedings No. P-82). Warrendale, PA, Society of Automotive Engineers, 263-88 (1979).
144. Cheng, R., Yang, K.H., Levine, R.S., King, A.I. Dynamic Impact Loading of the Femur Under Passive Restrained Condition. Proceedings of the 28th Stapp Car Crash Conference, Chicago, IL, November 6-7, 1984, (Society of Automotive Engineers Proceedings No. P-152). Warrendale, PA, Society of Automotive Engineers, 101-18 (1984).
145. Cheng, R., Yang, K.H., Levine, R.S., King, A.I., Morgan, R. Injuries to the Cervical Spine Caused by a Distributed Frontal Load to the Chest. Proceedings of the 26th Stapp Car Crash Conference, Ann Arbor, MI, October 20-21, 1982, (Society of Automotive Engineers Proceedings No. P-113) Warrendale, PA, Society of Automotive Engineers, 1-40 (1982).
146. Chou, C.C., Nyquist, G.W. Analytical Studies of the Head Injury Criterion (HIC). Presented at the Automotive Engineering Congress, Detroit, MI, February 25-March 1, 1974, (Society of Automotive Engineers Technical Paper No. 740082). New York, NY, Society of Automotive Engineers, 1-13 (1974).
147. Chubb, R.M., Detrick, W.R., Shannon, R.H. Compression Fractures of the Spine During USAF Ejections. *Aerosp Med* 1965 Oct, 36(10): 968-72.
148. Clark, B.A.J., Sarrailhe, S.R. Evaluations of a Modified Crew Seat for the Iroquois. ARL-APP-80, May 1980.
149. Clark, C.C., Jettner, E., Digges, K., Morris, J., Cohen, D., Griffith, D. Simulation of Road Crash Facial Lacerations by Broken Windshields. IN: Restraint Technologies: Front Seat Occupant Protection, (Society of Automotive Engineers Proceedings No. SP-690). Warrendale, PA, Society of Automotive Engineers, 175-97 (1987).
150. Clarke, N.P., Weis, E.B. Jr., Brinkley, J.W., Temple, W.E. Lateral Impact Tolerance Studies in Support of Apollo (Report 1). AMRL Memorandum M-29, February 1963.
151. Clarke, T.D., Gragg, C.D., Sprouffske, J.F., Trout, E.M., Zimmerman, R.M., Muzzy, W.H. Human Head Linear and Angular Accelerations During Impact. Proceedings of the 15th Stapp Car Crash Conference, Coronado, CA, November 17-19, 1971, (Society of Automotive Engineers Proceedings No. P-39). New York, NY, Society of Automotive Engineers, 1-12 (1971).

152. Clarke, T.D., Smedley, D.C., Muzzy, W.H., Gragg, C.D., Schmidt, R.E., Trout, E.M. Impact Tolerance and Resulting Injury Patterns in the Baboon: Air Force Shoulder Harness-lap Belt Restraint. Proceedings of the 16th Stapp Car Crash Conference, Detroit, MI, November 8-10, 1972, (Society of Automotive Engineers Proceedings No. P-45). New York, NY, Society of Automotive Engineers, 365-411 (1972).
153. Clarke, T.D., Sprouffske, J.F., Trout, E.M., Klopfenstein, H.S., Muzzy, W.H., Gragg, C.D., Bendixen, C.D. Baboon Tolerance to Linear Deceleration (-Gx): Lap Belt Restraint. Proceedings of the 14th Stapp Car Crash Conference, Ann Arbor, MI, November 17-18, 1970, (Society of Automotive Engineers Proceedings No. P-33). New York, NY, Society of Automotive Engineers, 272-8 (1970).
154. Clemedson, C.J., Granstom, J.A. Studies On the Genesis of "rib Markings" in Lung Blast Injury. Acta Physiol Scand 1950, 21, 131-144.
155. Clemedson, C.J., Jonsson, A. Dynamic Response of Chest Wall and Lung Injuries in Rabbits Exposed to Air Shock Waves of Short Duration. Acta Physiol Scand Suppl 1964, 62, 3-30.
156. The Clinical and Biomedical Evaluation of Trauma and Fatalities Associated with Aircrew Ejection and Crash. A Working Group Report. Neuilly-sur-Seine, France, Advisory Group for Aerospace Research and Development AGARD-AR-194, December 1984.
157. Coffee, M.S., Edwards, W.T., Hayes, W.C., White, A.A. 3d. Biomechanical Properties and Strength of the Human Cervical Spine. ASME Bioengineering Division Publication BED V.3. New York, NY, American Society of Mechanical Engineers. DE V 12, 1-12 (1987).
158. Collected Data On 48 Rocket Sled Experiments (Holloman AFB). NSL-65-94, May 1965.
159. Collins, T.A., Sawyer, C.H., Ferrari, V.J. Jr., Shannon, R.H. Five-year Injury Experience in Escape from USAF Ejection-seat-equipped Aircraft. Aerosp Med 1968 Jun, 39(6), 627-32, 1968.
160. Coltman, J.W. Design and Test Criteria for Increased Energy- Absorbing Seat Effectiveness. USAVRADCOM-TR-82-D-42, March 1983.
161. Coltman, J.W., Arndt, S.M. The Naval Aircraft Crash Environment: Aircrew Survivability and Aircraft Structural Response. TR-88490, September 1988.

162. **Coltman, J.W., Ingen, C.V., Selker, F. Crash-Resistant Crewseat Limit-Load Optimization Through Dynamic Testing with Cadavers. USAAVSCOM-TR-85-D-11, January 1986.**
163. **Combs, S.P. Correlation of Mechanism of Extremity Injury and Aerodynamic Factors in Ejections from F-4 Aircraft. IN: Models and Analogues for the Evaluation of Human Biodynamic Response, Performance and Protection. Neuilly-sur-Seine, France, Advisory Group for Aerospace Research and Development. AGARD-CP-253, A3-1-A-34 (June 1979).**
164. **Combs, S.P. Mechanism of Extremity Injuries Occurring During Ejection from F-4 Aircraft. Proceedings of the 16th Annual Symposium of the Survival and Flight Equipment Association, San Diego, CA, October 8-12, 1978. Canoga Park, CA, SAFE Association, 52-55 (1979).**
165. **Connors, M.P., Specker, L.J., Jennings, T.J. Development and Evaluation of a Device for the Prevention of Arm Flail Injuries. Presented at Annual Scientific Meeting of the Aerospace Medical Association meeting, Houston, TX, May 23-26, 1983. 178-9.**
166. **Conry, B.G., Hall, C.M. Cervical Spine Fractures and Rear Car Seat Restraints. Arch Dis Child, 62(12), 1267-8 (1987 Dec).**
167. **Cooke, F.W., Nagel, D.A. Biomechanical Analysis of Knee Impact. Proceedings of the 13th Stapp Car Crash Conference, Boston, MA, December 2-4, 1969, (Society of Automotive Engineers Proceedings No. P-28). New York, NY, Society of Automotive Engineers, 117-33 (1969).**
168. **Cooper, G.J., Bexon, R., Pearce, B.P., Stainer, M.C., Maynard, R.L. Prediction of Chest Wall Displacement and Heart Injury from Impact Characteristics of a Non-Penetrating Projectile, Bron, France, International Research Committee On the Biokinetics of Impacts (IRCOBI), 297-312 (September 1981).**
169. **Cooper, G.J., Pearce, B.P., Stainer, M.C., Maynard, R.L. The Biomechanical Response of the Thorax to Nonpenetrating Impact with Particular Reference to Cardiac Injuries. J Trauma, 22(12), 994-1008 (1982 Dec).**
170. **Cramer, H., Liu, Y.K., Von Rosenberg, D.U. Distributed Parameter Model of the Inertially Loaded Human Spine. Presented at the American Society of Mechanical Engineers Biomechanics Symposium, Atlanta, GA, June 20-22, 1973. New York, NY, American Society of Mechanical Engineers, 47-8 (1973).**
171. **Crash Injury Research. Summary Report. AD-132-220, September 1952.**

172. **Crowson, H.L. Statistical Analyses Applied to the U.S. Navy Aircrew Automated Escape Systems. NAVWESA-R-7606, November 1976.**
173. **Crowson, H.L. Statistical Analysis Methodology for the U.S. Navy Aircrew Automated Escape Systems. NAVWESA-R-7605, May 1976.**
174. **Culver, C.C., Haut, R.C., Nusholtz, G.S. Significance of Head-to-Knee Impacts: a Comparison of Dummy and Cadaver Responses. Proceedings of the 28th Stapp Car Crash Conference, Chicago, IL, November 6-8, 1984, (Society of Automotive Engineers Proceedings No. P-152). Warrendale, PA, Society of Automotive Engineers, 119-33 (1984).**
175. **Culver, R.H., Bender, M., Melvin, J.W. Mechanisms, Tolerances, and Responses Obtained Under Dynamic Superior-Inferior Head Impact: A Pilot Study, Morgantown, WV, National Institute for Occupational Safety and Health. UM-HSRI-78-21, May 1978.**
176. **Cummings, R.J. Investigation of Aircrew Protection During Emergency Escape at Dynamic Pressures Up to 1600 Q. AFAMRL-TR-81-71, May 1982.**
177. **Cummings, R.J., Adams, W.J. Aircrew Windblast Protection Concepts, Development and Evaluation. AFAMRL-TR-80-123, March 1982.**
178. **Cummings, S.R., Nevitt, M.C. A Hypothesis: the Causes of Hip Fractures. J Gerontol, 44(4), M107-11 (1989 Jul).**
179. **Current, J.D., Treanor, J.J., Sand, L.D. Back Injuries in Army Aviation Accidents. Biodynamics Data Bank, Wright-Patterson AFB, OH.**
180. **Daniel, R.P., Yost, C.D. The Design and Experimental Use of a Chest Load-Distribution Transducer and Force-Indicating Legs for the Part 572 Dummy. IN: Proceedings of the 25th Stapp Car Crash Conference, San Francisco, CA, September 28-30, 1981, (Society of Automotive Engineers Proceedings No. P-97). Warrendale, PA, Society of Automotive Engineers, 397-432 (1981).**
181. **Daniewicz, S., Collins, J.A., Pritz, H.B. Performance Enhancement of the Hybrid III Thorax. IN: Passenger Comfort, Convenience and Safety: Test Tools and Procedures, (Society of Automotive Engineers Proceedings No. P-174). Warrendale, PA, Society of Automotive Engineers, 299-304 (1986).**
182. **Darrah, M.I., Seavers, C.R., Wang, A.J., Dew, D.W. Acceleration Loading Tolerance of Selected Night Vision Goggle Systems—a Model Analysis. SAFE J, 17(2), 30-6 (1987).**

183. Day, D.R. The Dynamic Performance of a Variety of Seat Cushion Materials Under Vertical Impact Loads. Downsview, Ontario, Canada, Defense and Civil Institute of Environmental Medicine. DCIEM-88-TR-53, CTN-91-60207, December 1988.
184. Degroot, H. 3d, Mass, D.P. Hand Injury Patterns in Softball Players Using a 16-inch Ball. *Am J Sports Med*, 16(3), 260-5 (1988 May-Jun).
185. Delahaye, R.P., Auffret, R. Accidents in Centrifuges and Experiments (Ejection Seat Training Towers, Sleds). IN: *Physiopathology and Pathology of Spinal Injuries in Aerospace Medicine*. Neuilly-sur-Seine, France, Advisory Group for Aerospace Research and Development. AGARD-AG-250(ENG)-2ND, 132-135 (1982).
186. Delahaye, R.P., Auffret, R. Aetiology and Pathogenesis [Traumatic Lesions of the Spine]. IN: *Physiopathology and Pathology of Spinal Injuries in Aerospace Medicine*, Neuilly-sur-Seine, France, Advisory Group for Aerospace Research and Development. AGARD-AG-250(ENG)-2ND, 60-65 (1982).
187. Delahaye, R.P., Auffret, R., Doury, P., Kleitz, C., Leger, A. *Physiopathology and Pathology of Spinal Injuries in Aerospace Medicine*. 2nd Ed. Neuilly-sur-Seine, France, Advisory Group for Aerospace Research and Development. AGARD-AG-250(ENG)-2ND, 1982.
188. Delahaye, R.P., Carre, R., Auffret, R. Fractures of the Spine in Helicopter Accidents (Examination of 25 Cases). *Revue Med Aeronaut Spatiale*, 7(26), 131-133 (1968).
189. Delahaye, R.P., Metges, P.J. Radiology of Spinal Trauma in Aviation Medicine. IN: *Physiopathology and Pathology of Spinal Injuries in Aerospace Medicine*. Neuilly-sur-Seine, France, Advisory Group for Aerospace Research and Development. AGARD-AG-250(ENG)-2ND, 139-186 (1982).
190. Delahaye, R.P., Metges, P.J. Theories of the Pathogenesis of Fractures of the Spine. IN: *Physiopathology and Pathology of Spinal Injuries in Aerospace Medicine*. Neuilly-sur-Seine, France, Advisory Group for Aerospace Research and Development. AGARD-AG-250-(ENG)-2ND, 57-59 (1982).
191. DeLeys, N.J. An Evaluation of the Dynamic Performance Characteristics of Anthropomorphic Test Devices. Supplemental Data Report. Volume 2. Washington, D.C., U.S. Department of Transportation, National Highway Traffic Safety Administration. DOT-HS-800-870, June 1973.
192. Delgado, R.C. Limb Flail Injuries in USAF Ejections—1979-1985. *Proceedings of the 24th Annual Symposium of the Survival and Flight Equipment Association*, San Antonio, TX, December 11-13, 1986. Newhall, CA, SAFE Association, 1-3 (1987).

193. Deng, Y.C. Design Considerations for Occupant Protection in Side Impact: a Modeling Approach. Proceedings of the 32nd Stapp Car Crash Conference, Atlanta, GA, October 17-19, 1988, (Society of Automotive Engineers Proceedings No. P-215). Warrendale, PA, Society of Automotive Engineers, 71-9 (1988).
194. Deng, Y.C. Side Impact Simulation and Thoracic Injury Assessment. Proceedings of the 11th International Technical Conference On Experimental Safety Vehicles, Washington, D.C., May 12-15, 1987. Washington, D.C., U.S. Department of Transportation, National Highway Traffic Safety Administration, 77-86 (1987).
195. Denis, F. The Three-column Spine and Its Significance in the Classification of Acute Thoracolumbar Spinal Injuries. Spine, 8(8), 817-31 (1983 Nov-Dec).
196. Denton, R.A., Morgan, C.R. An Overview of Existing Sensors for the Hybrid III Anthropomorphic Dummy. Proceedings of the 11th International Technical Conference On Experimental Safety Vehicles, Washington, D.C., May 12-15, 1987. Washington, D.C., U.S. Department of Transportation, National Highway Traffic Safety Administration, 353-62 (1987).
197. DeSantis, K. Development of an Improved Multi-Directional Neck Prototype. Proceedings of the 35th Stapp Car Crash Conference, San Diego, CA, November 18-20, 1991 (Society of Automotive Engineers Proceedings No. P-251). Warrendale, PA, Society of Automotive Engineers, 435-46 (1991).
198. Dikshit, M.B., Sengupta, A.K. Unusual Ejection Injury—a Case Report. Aviat Med, 26, 119-22 (1982 Dec).
199. Dillon, L.R., King, P.I., Spenny, C.H. Aerodynamic Testing of a New Semi-prone Ejection Seat Design. Proceedings of the 28th AIAA Aerospace Sciences Meeting, Reno, NV, January 8-11 1990, AIAA-90-0234. 1-11 (1990).
200. DiLorenzo, F.A. Power and Bodily Injury, (Society of Automotive Engineers Technical Paper 760014). Warrendale, PA, Society of Automotive Engineers, 1-10 (1976).
201. Dobbs, H.S. Fracture of Femoral Components—An Act of God? Eng Med, 8(4), 237-240 (1979 Oct).
202. Dobbs, H.S. A Model to Predict the Incidence of Fracture in Femoral Components. J Bioeng, 1(3), 189-96 (1977 Aug).
203. Dogra, M.M., Kapur, R.R., Sundaram, P.M. An Analysis of Spinal Injuries After Ejections and Crash Landings in the IAF. Aviat Med, 26, 29-34 (1982 Jun).

204. Donnelly, B.R.; Morgan, R.M.; Eppinger, R.H. Durability, Repeatability and Reproducibility of the NHTSA Side Impact Dummy. Proceedings of the 27th Stapp Car Crash Conference, San Diego, California, October 17-19, 1983, (Society of Automotive Engineers Proceedings No. P-134). Warrendale, Pennsylvania, Society of Automotive Engineers, 299-310 (1983).
205. Donnelly, B.R., Roberts, D.P. Comparison of Cadaver and Hybrid III Dummy Response to Axial Impacts of the Femur. Proceedings of the 31st Stapp Car Crash Conference, New Orleans, LA, November 9-11, 1987, (Society of Automotive Engineers Proceedings No. P-202). Warrendale, PA, Society of Automotive Engineers, 105-16 (1987).
206. Dorsch, M.M., Woodward, A.J., Somers, R.L. Do Bicycle Safety Helmets Reduce Severity of Head Injury in Real Crashes? *Accid Anal Prev*, 19(3), 183-90 (1987 Jun).
207. Drummond, D.S., Craig, R.H., Dow, E. Non-penetrating Thoracic Trauma: a Statistical Survey and Analysis. *Can J Surg*, 9(4), 332-7 (1966 Oct).
208. Edwards, W.T., Crowell, R.R., Coffee, M.S., White, A.A. 3d. Mechanisms of Injury in the Cervical Spine. Proceedings of a Special Symposium On Maturing Technologies and Emerging Horizons, New Orleans, LA, November 4-7, 1988. New York, NY, IEEE, 123-9 (1988).
209. Edwards, W.T., Hayes, W.C., Kou, Y.F., Coffee, M.S., White, A.A. 3d. Fracture and Viscoelastic Characteristics of the Human Cervical Spine. AFOSR-TR-86-0453, 1986.
210. Eismont, F.J., Borja, F., Bohlman, H.H. Complete Dislocations at Two Adjacent Levels of the Cervical Spine. A Case Report. *Spine*, 9(3), 319-22 (1984 Apr).
211. Elias, J., Hamilton, M., Monk, M.W. Experimental Child Pedestrian Accident Reconstruction: Thoracic Impact. Final Report. Washington, D.C., U.S. Department of Transportation, National Highway Traffic Safety Administration. DOT-HS-807-420, October 1988.
212. Eliasson, P., Hansson, L.I., Karrholm, J. Displacement in Femoral Neck Fractures. A Numerical Analysis of 200 Fractures. *Acta Orthop Scand*, 59(4), 361-4 (1988 Aug).
213. Emori, R.I., Horiguchi, J. Whiplash in Low Speed Vehicle Collisions. IN: Vehicle Crashworthiness and Occupant Protection in Frontal Collisions, (Society of Automotive Engineers Proceedings No. SP-807). Warrendale, PA, Society of Automotive Engineers, 103-8 (1990).
214. Engin, A.E. The Axisymmetric Dynamic Response of a Fluid-filled Spherical Shell to a Local Radial Pulse—a Model for Head Injury. *J Biomech*, 2, 325-41 (1969).

215. Engin, A.E. Long Bone and Joint Response to Mechanical Loading. AFOSR-TR-82-0013, November, 1981.
216. Engin, A.E. Passive Resistive Torques About Long Bone Axes of Major Human Joints. Aviat Space Environ Med, 50(10), 1052-7 (1979 Oct).
217. Engin, A.E. Strain Energy Density Response of a Spherical Shell to an External Pulse: a Simple Model for Skull Fracture. Proceedings of the 8th Southeast Conference On Theoretical and Applied Mechanics, Blacksburg, VA, April 29-30, 1976. Blacksburg, VA, Virginia Polytechnic Institute and State University, 575-587 (1976).
218. Engin, A.E., Akkas, N. Application of a Fluid-filled Spherical Sandwich Shell as a Biodynamic Head Injury Model for Primates. Aviat Space Environ Med, 49(1 Pt. 2), 120-4 (1978 Jan).
219. Engin, A.E., Kazarian, L. Active Muscle Force and Moment Response of the Human Arm and Shoulder. Aviat Space Environ Med, 52, 523-530 (1981 Sept).
220. Engin, A.E., Liu, Y.K. Axisymmetric Response of a Fluid-filled Spherical Shell in Free Vibrations. J Biomech, 3(1), 11-22 (1970 Jan).
221. Engin, A.E., Moeinzadeh, M.H. Modeling of Human Joint Structures. AFAMRL-TR-81-117, September 1982.
222. Enouen, S.W. The Development of Experimental Head Impact Procedures for Simulating Pedestrian Head Injury. Proceedings of the 30th Stapp Car Crash Conference, San Diego, CA, October 27-29, 1986, (Society of Automotive Engineers Proceedings No. P-189). Warrendale, PA, Society of Automotive Engineers, 199-218 (1986).
223. Eppinger, R.H. Prediction of Thoracic Injury Using Measurable Experimental Parameters. Proceedings of the 6th International Technical Conference On Experimental Safety Vehicles, Washington, D.C., October 12-15, 1976. Washington, D.C., U.S. Department of Transportation, National Highway Traffic Safety Administration, 770-80 (1976).
224. Eppinger, R.H., Augustyn, K., Robbins, D.H. Development of a Promising Universal Thoracic Trauma Prediction Methodology. Proceedings of the 22nd Stapp Car Crash Conference, Ann Arbor, MI, October 24-26, 1978, (Society of Automotive Engineers Proceedings No. P-77). Warrendale, PA, Society of Automotive Engineers, 209-68 (1978).

225. Eppinger, R.H., Chan, H.S. Thoracic Injury Prediction Via Digital Convolution Theory. Proceedings of the 25th Stapp Car Crash Conference, San Francisco, September 28-30, 1981, (Society of Automotive Engineers Proceedings No. P-97). Warrendale, PA, Society of Automotive Engineers, 369-93 (1981).
226. Eppinger, R.H., Marcus, J.H., Morgan, R.M. Development of Dummy and Injury Index for NHTSA's Thoracic Side Impact Protection Research Program. Presented at the Government/Industry Meeting & Exposition, Washington, D.C., May 21-24, 1984, (Society of Automotive Engineers Technical Paper No. 840885). Warrendale, PA, Society of Automotive Engineers, 1-29 (1984).
227. Ernsting, J., King, P. eds. Aviation Medicine, 2nd edition. London, England: Butterworths, 1988.
228. Eroes, R. Accidents During Military Parachute Jumps in the Federal Armed Forces of the Federal Republic of Germany. Part 2. An Analysis of Accidents During About 200,000 Jumps at the Airborne and Air Transport School, 1975-1980. FSTC-HT-0055-88-PT-2, April 1988.
229. Esses, S.I., Lotz, J.C., Hayes, W.C. Biomechanical Properties of the Proximal Femur Determined in Vitro by Single-Energy Quantitative Computed Tomography. J Bone Miner Res, 4(5), 715-22 (1989 Oct).
230. Eurell, J.A.C. Analysis of Long Bone and Vertebral Failure Patterns. TR-85-0454, February 1985.
231. Every, M.G. A Summary of Navy Air Combat Escape and Survival. Falls Church, VA, Biotechnology, Inc. February 1977.
232. Every, M.G., Parker, J.F. Jr. Aircraft Escape and Survival Experiences of Navy Prisoners of War. Presented at the Annual Scientific Meeting of the Aerospace Medical Association. August 1974.
233. Every, M.G., Parker, J.F. Jr. Biomedical Aspects of Aircraft Escape and Survival Under Combat Conditions. Falls Church, VA, Biotechnology, Inc. March 1976.
234. Ewing, C.L. Injury Criteria and Human Tolerance for the Neck. IN: Aircraft Crashworthiness. Saczalski, K., Singley, G.T.3d, Pilkey, W., Huston, R.L., eds. (Proceedings of a Symposium, Cincinnati, OH, October 6-8, 1975). Charlottesville, VA, University of Virginia Press, 1-11 (1975).
235. Ewing, C.L. Non-fatal Ejection Vertebral Fracture, U.S. Navy Fiscal Years 1959 Through 1965: Costs. Aerosp Med, 42(11), 1226-8 (1971 Nov).

236. Ewing, C.L. Non-fatal Ejection Vertebral Fracture and Its Prevention [Nonfatal Ejection Vertebral Fracture Comparison Between U.S., British and Swedish Armed Services]. IN: Current Status in Aerospace Medicine. Neuilly-sur-Seine, France, Advisory Group for Aerospace Research and Development AGARD-CP-110, C2-1-C2-8 (February 1973).
237. Ewing, C.L., King, A.I., Prasad, P. Structural Considerations of the Human Vertebral Column Under +Gz Impact Acceleration. *J Aircraft*, 9(1), 84-90 (1972 Jan).
238. Ewing, C.L., King, A.I., Prasad, P., Vulcan, A.P. A Method for Increasing the Threshold Level for Vertebral Fracture Due to +Gz Impact Acceleration. Biodynamics Data Bank, Wright-Patterson AFB. OH.
239. Ewing, C.L., Thomas, D.J. Bioengineering Aspects of Spinal Injury in the OV-1 (Mohawk). IN: Escape Problems and Manoeuvres. Neuilly-sur-Seine, France, Advisory Group for Aerospace Research and Development. AGARD-CP-134, A2-1-A2-9 (February 1974).
240. Ewing, C.L., Thomas, D.J., Lustik, L., Muzzy, W.H. 3d, Willems, G.C., Majewski, P. Dynamic Response of the Human Head and Neck to +Gy Impact Acceleration. Proceedings of the 21st Stapp Car Crash Conference, New Orleans, LA, October 19-21, 1977, (Society of Automotive Engineers Proceedings No. P-73). Warrendale, PA, Society of Automotive Engineers, 549-586 (1977).
241. Ewing, C.L., Thomas, D.J., Majewski, P.L., Black, R., Lustik, L. Measurement of Head, T₁, and Pelvic Response to -Gx Impact Acceleration. Proceedings of the 21st Stapp Car Crash Conference, New Orleans, LA, October 19-21, 1977, (Society of Automotive Engineers Proceedings No. P-73). Warrendale, PA, Society of Automotive Engineers, 509-545 (1977).
242. Faerber, E. Crash Test Variability Dummy and Vehicle Responses. Proceedings of the 1988 International Conference On the Biomechanics of Impacts (IRCOBI), Bergisch-Gladbach, Germany, September 14-16, 1988. Bron, France, IRCOBI, 111-130 (1988).
243. Faerber, E., Kramer, F. On the Application of the HIC as Head Protection Criterion. Proceedings of the 1985 International Conference On the Biomechanics of Impacts (IRCOBI), Bergisch-Gladbach, Germany, September 14-16, 1988. Bron, France, IRCOBI, 235-252 (1985).
244. Fan, W.R. Internal Head Injury Assessment. Proceedings of the 15th Stapp Car Crash Conference, Coronado, CA, November 17-19, 1971, (Society of Automotive Engineers Proceedings No. P-39). New York, NY, Society of Automotive Engineers, 645-65 (1971).

245. Farfan, H., Gracovetsky, S., Helleur, C. Cervical Spine Analysis for Ejection Injury Research. AFOSR-TR-83-0590, November 30, 1982.
246. Farr, W.D., Ruehle, C.J., Posey, D.M., Wagner, G.N. Injury Pattern Analysis of Helicopter Wire Strike Accidents (-Gz Load). Aviat Space Environ Med, 56(12), 1216-9 (1985 Dec).
247. Fayon, A., Tarriere, C., Walfisch, G., Got, C., Patel, A. Contribution to Defining a Tolerance Level for a Laterally Impacted Human Head. Proceedings of the 6th International Technical Conference On Experimental Safety Vehicles, Washington, D.C., October 12-15, 1976. Washington, D.C., U.S. Department of Transportation, National Highway Traffic Safety Administration, 690-703 (1976).
248. Felder, U.W., Lombard, C.F., Mattingly, T.E. Investigation of Vibration and Impact Protection of the Human Head and Neck. AMRL-TR-69-112, December 1969.
249. Ferrari, V.J. Jr., Shannon, R.H. USAF Ejection Experience in the Combat Environment—January 1, 1967-June 30, 1968. Proceedings of the 6th Annual Symposium of the Survival and Flight Equipment Association, San Diego, CA, October 1-3, 1968. San Diego, CA, SAFE Association, B49-B55 (1968).
250. Fesmire, F.M., Luten, R.C. The Pediatric Cervical Spine: Developmental Anatomy and Clinical Aspects. J Emerg Med, 7(2), 133-42 (1989 Mar-Apr).
251. Fielding, J.W. Subtrochanteric Fractures. Clin Orthop, 92, 86-99 (1973 May).
252. Findlay, J.A. The Motor-cycle Tibia. Injury, 4(1), 75-8 (1972 Aug).
253. Firth, J.L. Return to Flying After Head Injuries: a Review. Aviat Space Environ Med, 54(7), 603-8 (1983 Jul).
254. Fleck, J.T. Calspan Three-dimensional Crash Victim Simulation Program. IN: Aircraft Crashworthiness. (Proceedings of a Symposium, Cincinnati, OH, October 6-8, 1975). Charlottesville, VA, University Press of Virginia, 299-310 (1975).
255. Fleck, J.T., Butler, F.E. Development of an Improved Computer Model of the Human Body and Extremity Dynamics. AMRL-TR-75-14, July 1975.
256. Fleming, C. Ejection Problems and Injuries: Their Causes, Effects and Treatments, and Suggestions for Preventive Measures. Aviat Space Environ Med 1979 Aug, 50(8), 829-33.

257. Fletcher, E.R. A Model to Simulate Thoracic Responses to Air Blast and to Impact. Presented at the Symposium On Biodynamics Models and Their Applications, Dayton, OH, October 26-28, 1970. AMRL-TR-29, Paper 1, 27-70 (1970).
258. Foust, D.R., Bowan, B.M., Snyder, R.G. Study of Human Impact Tolerance Using Investigations and Simulations of Free-falls. Proceedings of the 21st Stapp Car Crash Conference, New Orleans, LA, October 19-21, 1977, (Society of Automotive Engineers Proceedings No. P-73). Warrendale, PA, Society of Automotive Engineers, 1-52 (1977).
259. Fox, J.C., Williams, J.F. Mathematical Model for Investigating Combined Seatback-head Restraint Performance During Rear-end Impact. Med Biol Eng, 14(3), 263-73 (1976 May).
260. Frankel, V.H., Burstein, A.H., Brooks, D.B. Biomechanics of Internal Derangement of the Knee. Pathomechanics as Determined by Analysis of the Instant Centers of Motion. J Bone Joint Surg [Am], 53(5), 945-62 (1971 Jul).
261. Fries, H. Vertebral Ejection Fractures: a Review and Recent Experience in the Swedish Air Force. Biodynamics Data Bank, Wright-Patterson AFB, OH.
262. Frisch, G.D. The Development of a Instrumented Human-like Pelvis for Incorporation into State-of-the-art Manikins. Proceedings of the 25th Annual Symposium of the Survival and Flight Equipment (SAFE) Association, Las Vegas, NV, November 16-19, 1987. Newhall, CA, SAFE Association, 224-229 (1987).
263. Frisch, G.D., D'Aulerio, L., O'Rourke, J. Mechanism of Head and Neck Response to -Gx Impact Acceleration: a Math Modeling Approach. Aviat Space Environ Med, 48(3), 223-30 (1977 Mar).
264. Frisch, G.D., Daulerio, L.A. A Standardized Instrumentation Methodology for Assessing Ejection Seat Performance. Proceedings of the 19th Annual Symposium of the Survival and Flight Equipment Association, Las Vegas, NV, December 6-10, 1981. Van Nuys, CA, SAFE Association, 55-61 (1982).
265. Frisch, G.D., Frisch, P.H. The Development of a Dynamic Response Sensing and Recording System for Incorporation into a State-of-the-art Manikin. SAFE J, 14, 13-20 (1984 Spring).
266. Frisch, G.D., Kinker, L.E., Frisch, P.H. Measurement Techniques, Evaluation Criteria and Injury Probability Assessment Methodologies Developed for Navy Ejection and Crashworthy Seat Evaluations. IN: Neck Injury in Advanced Military Aircraft Environments. Neuilly-sur-Seine, France, Advisory Group On Aerospace Research and Development. AGARD-L-CP-471, 21-8 (February 1990).

267. Frisch, G.D., Miller, K., Frisch, P.H. Spinal Response/injury Assessment During Various Ejection and Crash Scenarios Employing Manikin Based Load and Torque Measurements. Proceedings of the 26th Annual Symposium of the Survival and Flight Equipment Association, Las Vegas, NV, December 5-8, 1989. Newhall, CA, SAFE Association, 220-226 (1989).
268. Frisch, G.D., O'Rourke, J., D'Aulerio, L. The Effectiveness of Mathematical Models as a Human Analog. IN: Mathematical Modeling Biodynamic Response to Impact. (Society of Automotive Engineers Proceedings No. SP-412). Warrendale, PA, Society of Automotive Engineers, 61-73 (1976).
269. Frisch, G.D., Whitley, P.E., Frisch, P.H. The Development of a New Manikin Prototype and Instrumentation System for Crash/impact Testing. Presented at the National Specialists' Meeting On Crashworthy Design of Rotorcraft, Atlanta, GA, April 7-9, 1986. Alexandria, VA, American Helicopter Society, 1986.
270. Frisch, G.D., Whitley, P.E., Wydra, G., Holdaway, D. High Speed Ejection Tests of a Modified Hybrid III Manikin. Proceedings of the 23rd Annual Symposium of the Survival and Flight Equipment Association, Las Vegas, NV, December 1-5, 1985. Van Nuys, CA, SAFE Association, 93-101 (1986).
271. Frisch, G.D., Whitley, P.E., Frisch, P.H. Structural Integrity Tests of a Modified Hybrid III Manikin and Supporting Instrumentation System. Proceedings of the 22nd Annual Symposium of the Survival and Flight Equipment Association, Las Vegas, NV, December 9-13, 1984. Van Nuys, CA, SAFE Association, 6-13 (1985).
272. Frisch, P.H., Ayoub, P. Enhanced Anatomically Representative Manikin Pelvis Supporting a Self-contained Instrumentation/electronics Subsystem. SAFE J, 20, 35-40 (1990 Fall).
273. Gable, W.D. Pathology Patterns in Aircraft Accident Investigation. Aerosp Med, 39(6), 638-40 (1968 Jun).
274. Gadd, C.W., Culver, C.C., Nahum, A.M. A Study of Responses and Tolerances of the Neck. Proceedings of the 15th Stapp Car Crash Conference, Coronado, CA, November 17-19, 1971, (Society of Automotive Engineers Proceedings No. P-39). New York, NY, Society of Automotive Engineers, 1J-9J (1971).
275. Gadd, C.W., McLeod, D.G. An Anatomical Skull for Impact Testing. Warren, MI, General Motors Research Laboratories. GMR-1284, HS-012 477, 1972.

276. Gadd, C.W., Patrick, L.M. System Versus Laboratory Impact Tests for Estimating Injury Hazard. Presented at the Automotive Engineering Congress, Detroit, MI, January 8-12, 1968, (Society of Automotive Engineers Technical Paper No. 680053). New York, NY, Society of Automotive Engineers, 1-8 (1968).
277. Gehweiler, J.A. Jr., Clark, W.M., Schaaf, R.E., Powers, B., Miller, M.D. Cervical Spine Trauma: the Common Combined Conditions. *Radiology*, 130(1), 77-86 (1979 Jan).
278. General Motors Corporation Response to the Department of Transportation Request for Information On the Evaluation of the Hybrid III Dummy (HS-021 483). Warren, MI, General Motors Corporation, 1977.
279. Gennarelli, T.A. Mechanisms and Pathophysiology of Cerebral Concussion. *J Head Trauma Rehabil*, 1, 23-9, (1986).
280. Gennarelli, T.A. State-of-the-Art of Head Injury Biomechanics: A Review (The George A. Snively Memorial Lecture). Proceedings of the 29th Annual Conference of the American Association for Automotive Medicine, Washington, D.C., October 7-9, 1985. Arlington Heights, IL, American Association for Automotive Medicine, 447-63 (1985).
281. Gennarelli, T.A., Adams, J.H., Graham, D.I. Acceleration Induced Head Injury in the Monkey. I. The Model, Its Mechanical and Physiological Correlates. *Acta Neuropathol Suppl (Berl)*, 7, 23-5 (1981).
282. Gennarelli, T.A., Thibault, L.E. Acceleration Damage to the Brain. IN: *Impact Injury Caused by Linear Acceleration: Mechanisms, Prevention and Cost*. Neuilly-sur-Seine, France, Advisory Group for Aerospace Research and Development. AGARD-CP-322, 10-1-10-9 (1982).
283. Gennarelli, T.A., Thibault, L.E. Biomechanics of Acute Subdural Hematoma. *J Trauma*, 22(8), 680-6 (1982 Aug).
284. Genarelli, T.A., Thibault, L.E. Clinical Rationale for a Head Injury Angular Acceleration Criteria. Proceedings of a Conference, Head Injury Mechanisms: The Need for an Angular Acceleration Criterion, Washington, D.C., October 4, 1989. Des Plaines, IL, Association for the Advancement of Automotive Medicine, 1989.
285. Gennarelli, T.A., Thibault, L.E., Ommaya, A.K. Pathophysiologic Responses to Rotational and Translational Accelerations of the Head. Proceedings of the 16th Stapp Car Crash Conference, Detroit, MI, November 8-10, 1972, (Society of Automotive Engineers Proceedings No. P-45). New York, NY, Society of Automotive Engineers, 296-308 (1972).

286. Gennarelli, T.A., Thibault, L.E., Adams, J.H., Graham, D.I., Thompson, C.J., Marcincin, R.P. Diffuse Axonal Injury in the Primate. *Ann Neurol*, 12, 564-74 (1982).
287. Gersbach, V.S, Musseler, P.M. Dummy Design and Reaction at Impact Simulation. Presented at the International Automotive Engineering Congress & Exposition, Detroit, MI, February 28-March 4, 1977, (Society of Automotive Engineers Technical Paper No. 770262). Warrendale, PA, Society of Automotive Engineers, 1-14 (1977).
288. Gillingham, K.K., Krutz, R.W. Jr. Effects of the Abnormal Acceleratory Environment of Flight. SAM-REVIEW-10-74, SAM-TR-74-57, December 1974.
289. Glaeser, K.P. Results of Side Impact Tests with the EUROSID. Proceedings of the 31st Stapp Car Crash Conference, New Orleans, November 9-11, 1987, (Society of Automotive Engineers Proceedings No. P-202). Warrendale, Pennsylvania, Society of Automotive Engineers, 117-27 (1987).
290. Glaister, D.H. Biodynamic Response to Windblast [Conference Proceedings]. Neuilly-sur-Seine, France, Advisory Group for Aerospace Research and Development. AGARD-CP-170, July 1975.
291. Glaister, D.H. Evaluation of Aircrew Protective Helmets Worn During Crashes and Ejections. FPRC-1330, May 1974.
292. Glaister, D.H. A New Standard for Protective Headgear—BS 6658. Proceedings of the 23rd Annual Symposium of the Survival and Flight Equipment Association, Las Vegas, NV, December 1-5, 1985. Van Nuys, CA, SAFE Association, 190-193 (1986).
293. Glaister, D.H. Physiological Limitations to High Speed Escape. IN: 4th Advanced Operational Aviation Medicine Course Held at Royal Air Force Institute of Aviation Medicine, Fanborough, Hampshire, June 17-26, 1975. Neuilly-sur-Seine, France, Advisory Group for Aerospace Research and Development (AGARD), May 1976.
294. Golden, F.S. Spinal Injury Resulting from Ejection from Royal Naval Aircraft, 1960-1968 Survey On Vertebrae Fractures of Flying Personnel Caused by Ejection from Navy Aircraft. IN: Medical—Legal Aspects of Aviation. Neuilly-sur-Seine, France, Advisory Group On Aerospace Research and Development (AGARD), September 1970.
295. Goldsmith, W. Critical Impact and Acceleration Loading to the Head. Presented at the 7th Annual Meeting of the International Union of Physiological Sciences, Commission On Gravitational Physiology, Niagara Falls, NY, October 13-18, 1985. Published as a Supplement to *Physiologist*, 28, S21-S24 (December 1985).
296. Goldsmith, W. Current Controversies in the Stipulation of Head Injury Criteria. *J Biomech*, 14(12), 883-4 (1981).

297. Goldsmith, W., Ommaya, A.K. Head and Neck Injury Criteria and Tolerance Levels. IN: Aldman, B. And Chapon, A., Eds. The Biomechanics of Impact Trauma. Amsterdam, Netherlands, Elsevier: 149-87 (1984).
298. Gonsalves, J.E. A Study of Helicopter Accident Data to Determine the Feasibility of a Survival Escape System. D8-0444, February 1968.
299. Gordon, S.L., Moskowitz, G.D., Byers, R. Analysis of a Multilayered Spherical Head-Impact Model. J Eng Industry, Trans ASME, 534-540 (1974 May).
300. Got, C., Guillon, F., Patel, A., Mack, P., Brun-Cassan, F., Fayon, A., Tarriere, C., Hureau, J. Morphological and Biomechanical Study of 146 Human Skulls Used in Experimental Impacts, in Relation with the Observed Injuries. Proceedings of the 27th Stapp Car Crash Conference, San Diego, CA, October 17-19, 1983, (Society of Automotive Engineers Proceedings No. P-134). Warrendale, PA, Society of Automotive Engineers, 241-59 (1983).
301. Gracovetsky, S., Farfan, H.F., Helleur, C.D. Cervical Spline Analysis for Ejection Injury Prediction. Final Research Report Oct 80-Sep 82. AFOSR-TR-83-0590, November 30, 1992.
302. Graf, P.A., Mohlman, H.T. Accuracy of Digitized Photometric Data. AMRL-TR-79-76, April 1980.
303. Gragg, C.D. Could Anthropometric Dummy Data Be Used to Predict Injury to Humans? Proceedings of the 22nd Annual Symposium of the Survival and Flight Equipment Association, Las Vegas, NV, December 9-13, 1984. Van Nuys, CA, SAFE Association, 233-236 (1985).
304. Gragg, C.D. Open Seat Ejection at High Dynamic Pressure—a Radical Approach. SAFE J, 12(4), 14-18 (1981).
305. Griffin, C.R. Spinal Ejection Injuries. Proc R Soc Med, 68(11), 722-3 (1975 Nov).
306. Groesch, L. Chest Injury Criteria for Combined Restraint Systems. Presented at the Government/industry Meeting and Exposition, Washington D.C., May 20-23, 1985, (Society of Automotive Engineers Technical Paper No. 851247). Warrendale, PA, Society of Automotive Engineers, 1-4 (1985).
307. Groesch, L. Injury Criteria for Combined Restraint Systems. Proceedings of the 10th International Technical Conference On Experimental Safety Vehicles, Oxford, England, July 1-4, 1985. Washington, D.C., U.S. Department of Transportation, National Highway Traffic Safety Administration, 338-42 (1985).

308. Groesch, L., Kaiser, H.-P., Schmid, W. **Mathematical Movement and Load Simulation for Persons Involved in an Automobile Accident.** *Int J Vehicle Design*, 7(5-6), 41-8 (1986 Sep).
309. Groesch, L., Katz, E., Kassing, L., Marwitz, H., Zeidler, F. **New Measurement Methods to Assess the Improved Protection Potential of Airbag Systems.** IN: **Restraint Technologies: Front Seat Occupant Protection**, (Society of Automotive Engineers Proceedings No. SP-690). Warrendale, PA, Society of Automotive Engineers, 161-6 (1987).
310. Grood, E., Noyes, F., Butler, D. **Knee Flail Design Limits: Background, Experimentation and Design Criteria.** AMRL-TR-78-58, October 1978.
311. Guill, F.C. **Ascertaining the Causal Factors for "ejection-associated" Injuries.** *Aviat Space Environ Med*, 60(10 Pt 2), B44-71 (1989 Oct).
312. Guill, F.C. **Aircrew Automated Escape Systems (AAES). In-Service Usage Data Analysis Program. Papers Presented at the 17th Annual Fallsafe meeting, Corpus Christi, TX, February 8-12, 1982.** AD-A172051.
313. Guill, F.C. **Factors Influencing the Incidence and Severity of "ejection-associated" Neck Injuries Sustained by U.S. Navy Ejectees January 1, 1969 Through December 31, 1979—a Preliminary Report.** Proceedings of the 21st Annual Symposium of the Survival and Flight Equipment Association, San Antonio, TX, November 5-8, 1984. Van Nuys, CA, SAFE Association, 217-230 (1984).
314. Guill, F.C. **Pre-escape and Escape Aircraft Maneuvers and Gyration: a Critical Under-reported Problem Affecting Escape System Performance and Aircrew Safety.** *Aviat Space Environ Med*, 60(10 Pt 2), B11-23 (1989 Oct).
315. Guill, F.C. **Preliminary Generalized Thoughts Concerning Ejection Flail Phenomena.** Proceedings of the 19th Annual Symposium of the Survival and Flight Equipment Association, Las Vegas, NV, December 6-10, 1981. Van Nuys, CA, SAFE Association, 13-14 (1982).
316. Guill, F.C., Herd, G.R. **Aircrew Neck Injuries: A New, or an Existing, Misunderstood Phenomenon.** IN: **Neck Injury in Advanced Military Aircraft Environments.** Neuilly-sur-Seine, France, Advisory Group for Aerospace Research and Development. AGARD-CP-471, 9-1-9-12 (1990).
317. Guill, F.C., Herd, G.R. **An Evaluation of Proposed Causal Mechanisms for "ejection Associated" Neck Injuries.** *Aviat Space Environ Med*, 60(7 Pt 2), A26-47 (1989 Jul).

318. **Gurdjian, E.S. Recent Advances in the Study of the Mechanism of Impact Injury of the Head. Biodynamics Data Bank, Wright-Patterson AFB, OH.**
319. **Gurdjian, E.S., Roberts, V.L., Thomas, L.M. Tolerance Curves of Acceleration and Intracranial Pressure and Protective Index in Experimental Head Injury. J Trauma, 6(5), 600-604 (1966 Sep).**
320. **Gustin, T. Limb Restraint Evaluator. Proceedings of the IEEE 1985 National Aerospace and Electronics Conference, Dayton, OH, May 20-24, 1985. New York, NY, IEEE, 952-956 (1985).**
321. **Hackney, J.R., Gabler, H.C., Kaniyantra, J.N., Cohen, D.S. Update of the NHTSA Research Activity in Thoracic Side Impact Protection for the Front Seat Occupant. Proceedings of the 31st Stapp Car Crash Conference, New Orleans, LA, November 9-11, 1987, (Society of Automotive Engineers Proceedings No. P-202). Warrendale, PA, Society of Automotive Engineers, 129-42 (1987).**
322. **Hackney, J.R., Monk, M.W., Hollowell, W.T., Sullivan, L.K., Willke, D.T. Results of the National Highway Traffic Safety Administration's Thoracic Side Impact Protection Research Program. Presented at the Government/Industry Meeting & Exposition, Washington, D.C., May 21-24, 1984, (Society of Automotive Engineers Technical Paper No. 840886). Warrendale, PA, Society of Automotive Engineers, 1-34 (1984).**
323. **Haley, J.L., Jr., Ed. Impact Injury Caused by Linear Acceleration: Mechanisms, Prevention and Cost. Neuilly-sur-Seine, France, Advisory Group for Aerospace Research and Development. AGARD-CP-322, April 1982.**
324. **Hallel, T., Naggan, L. Parachuting Injuries: a Retrospective Study of 83, 718 Jumps. J Trauma, 15(1), 14-9 (1975 Jan).**
325. **Hanson, P.G. Cardiac Displacement and Thoracic Vascular Trauma Resulting from Abrupt Deceleration of Dogs. Aerosp Med, 38(12), 1259-63 (1967 Dec).**
326. **Harger, J.H., Huelke, D.F. Femoral Fractures Produced by Projectiles--the Effects of Mass and Diameter On Target Damage. J Biomech, 3(5), 487-93 (1970 Oct).**
327. **Harris, C.N., Wood, V.E. Rollover Injuries of the Upper Extremity. J Trauma, 18(8), 605-7 (1978 Aug).**
328. **Harris, G.F., Yoganandan, N., Pintar, F., Sances, A. Jr. Vertical Drop Impact Test System for Head Injury Assessment: Biomechanical Design and Analysis. Presented at the Winter Annual Meeting of the American Society of Mechanical Engineers, Chicago, IL, November 27-December 2, 1988. New York, NY, American Society of Mechanical Engineers, 93-4 (1988).**

329. Harris, J.H. Jr. Acute Injuries of the Spine. *Semin Roentgenol*, 13(1), 53-68 (1978 Jan).
330. Harrison, W.D. Aircrew Experiences in USAF Ejections, 1971-1977. *Proceedings of the 16th Annual Symposium of the Survival and Flight Equipment Association*, San Diego, CA, October 8-12, 1979. Canoga Park, CA, SAFE Association, 47-51 (1979).
331. Hasbrook, A.H. Gross Pattern of Injury of 109 Survivors of Five Transport Accidents. AV-CIR-5-SS-96, July 1958.
332. Hass, G. An Analysis of Relations Between Force, Aircraft Structure and Injuries to Personnel Involved in Aircraft Accidents with Recommendations for Safer Principles and Design of Certain Types of Aircraft. Randolph AFB, TX, School of Aviation Medicine. November 1, 1943.
333. Hassan, N.H. Some Observations On Bail-out Injuries. *Med Aeronautique Et Spatiale*, 21, 390-391 (1982 4th Quarter).
334. Haut, R.C. Contact Pressures in the Patellofemoral Joint During Impact Loading On the Human Flexed Knee. *J Orthop Res*, 7(2): 272-80 (1989).
335. Haut, R.C., Gadd, C.W., Madeira, R.G. Nonlinear Viscoelastic Model for Head Impact Injury Hazard. *Proceedings of the 16th Stapp Car Crash Conference*. Detroit, MI, November 8-10, 1972, (Society of Automotive Engineers Proceedings No. P-45). Warrendale, PA, Society of Automotive Engineers, 149-59 (1982).
336. Hawker, F.W., Euler, A.J. Wind Tunnel Measurements of Vertical Acting Limb Flail Forces and Torso/Seat Back Forces in an ACES-II Ejection Seat. AMRL-TR-76-3.
337. Hayes, W.C., Piazza, S.J., Zysset, P.K. Biomechanics of Fracture Risk Prediction of the Hip and Spine by Quantitative Computed Tomography. *Radiol Clin North Am*, 29(1), 1-18 (1991 Jan).
338. Hazzard, R.C. Retro-hyperflexion Luxation: Mechanism of Cervical Spinal Cord Contusion Injury During Ejection Sequence. *Aviat Space Environ Med*, 52(10), 625-6 (1981 Oct).
339. Head and Neck Injury Criteria. A Consensus Workshop. Washington, D.C., U.S. Department of Transportation, National Highway Traffic Safety Administration, July 1983.
340. Hearn, B.M., Sarrailhe, S.R. Simulated Head Impact On a Fiber Glass Seat Back. Melbourne, Victoria, Australia, Australian Defence Scientific Service, June 1969.

341. **Hearon, B.F. F/FB-111 Ejection Experience (1967-1980). Part II. Summary of Accident Investigation Reports. AFARML-TR-81-114, November 1981.**
342. **Hearon, B.F., Brinkley, J.W., Luciani, R.J., Von Gierke, H.E. F/ FB-111 Ejection Experience (1967-1980). Part I. Evaluation and Recommendations. AFAMRL-TR-81-113, November 1981.**
343. **Hearon, B.F., Brinkley, J.W., Raddin, J.H.Jr., and Fleming, B.W.Jr. Knee Ligament Injury During Lateral Impact. Aviat, Space Environ Med, 56(1), 1-9 (January 1985).**
344. **Hearon, B.F., Thomas, H.A., Raddin, J.H. Jr. Mechanism of Vertebral Fracture in the F/FB-111 Ejection Experience. Aviat Space Environ Med, 53(5), 440-8 (1982 May).**
345. **Hendler, E., Schulman, M. Restraint of the Head During Acceleration [Inflated Air Bag Head Restraints for Prevention of Brain Injuries Due to Whiplash Acceleration During Crash Landings Or Ejection]. Proceedings of the 10th Annual Symposium of the Survival and Flight Equipment Association, Phoenix, AZ, October 2-5, 1972. Canoga Park, CA, SAFE Association, 26-29, (1972).**
346. **Henry, J.P. Studies of the Physiology of Negative Acceleration: An Approach to the Problem of Protection. AF-TR-5953, October 1950.**
347. **Henzel, J.H. The Human Spinal Column and Upward Ejection Acceleration—An Appraisal of Biodynamic Implications. Wright-Patterson AFB, OH, Aerospace Medical Research Laboratories, September 1967.**
348. **Henzel, J.H., Clark, N.P., Mohr, G.C., Weis, E.B. Jr. Compression Fractures of Thoracic Vertebrae Apparently Resulting from Experimental Impact. A Case Report. AMRL-TR-65-134, August 1985.**
349. **Henzel, J.H., Mohr, G.C., Von Gierke, H.E. Reappraisal of Biodynamic Implications of Human Ejections. Aerosp Med, 39(3), 231-40 (1968 Mar).**
350. **Herd, G.R. Flail, Tumble and Windblast [During Ejection]. Proceedings of the 20th Annual Symposium of the Survival and Flight Equipment Association, Las Vegas, NV, December 6-10, 1982. Van Nuys, CA, SAFE Association, 237-240 (1983).**
351. **Hershey, R.L., Higgins, T.H. Application of the Response Probability Density Function Technique to Biodynamic Models. FAA-RD-77-52, April 1977.**

352. Hess, R.L. Review of Literature and Regulation Relating to Head Impact Tolerance and Injury Criteria. Appendix C. NCSS (National Crash Severity Study) Head Injury Accident Data. Special Report July 1978-June 1980. Ann Arbor, MI, University of Michigan, Highway Safety Research Institute. July 1980.
353. Hess, R.L., Weber, K., Melvin, J.W. Review of Literature and Regulation Relating to Head Impact Tolerance and Injury Criteria. Special Report July 1978-June 1980. Ann Arbor, MI, University of Michigan, Highway Safety Research Institute. July 1980.
354. Hess, R.L., Weber, K., Melvin, J.W. Review of Research On Thoracic Impact Tolerance and Injury Criteria Related to Occupant Protection. IN: Occupant Crash Interaction with the Steering System, (Society of Automotive Engineers Proceedings No. SP-507). Warrendale, PA, Society of Automotive Engineers, 93-119 (1982).
355. Hess, R.L., Weber, K., Melvin, J.W. Review of Literature and Regulation Relating to Thoracic Impact Tolerance and Injury Criteria. Final Report July 1980-June 1981. Ann Arbor, MI, University of Michigan, Highway Safety Research Institute. UM-HSRI-81-38, July 1981.
356. Hickling, R., Wenner, M.L. Mathematical Model of a Head Subjected to an Axisymmetric Impact. J Biomech, 6, 115-132 (1973).
357. Hicks, J.E., Adams, B.H., Shanahan, D.F. Analysis of U.S. Army Aviation Mishap Injury Patterns. USAARL-82-2, 1982.
358. Higgins, A.M., Roberts, E.O. The USAF's CREST Program—Phase I. SAFE J, 6, 38-45 (1986 Winter).
359. Higgins, L.S., Schmall, R.A., Brown, H.E., Howard, R.H., Brockway, J.A. The Investigation of Vertebral Injury Sustained During Aircrew Ejection. Phase 2a: Basic Science Experimental Design and Investigation of Dynamic Characteristics of Vertebral Columns Considered as an Engineering Structure. San Antonio, TX, Technology Incorporated, Life Sciences Division, November 1, 1966-October 31, 1967.
360. Hight, T.K. Development of a Strain Rate Dependent Long Bone Injury Criterion for Use with the ATB Model. AFOSR-81-0062, January 1982.
361. Hight, T.K. Long Bone Injury Criteria for Use with the Articulated Total Body Model. AFAMRL-TR-81-3, January 1981.
362. Hill, I.R. Mechanism of Injury in Aircraft Accidents—A Theoretical Approach. Aviat Space Environ Med, 60(7 Pt 2): A18-25 (1989 Jul).

363. Hirsch, A.E. Man's Response to Shock Motion. Proceedings of the Winter Annual Meeting of the American Society of Mechanical Engineers, Philadelphia, PA, November 17-22, 1963. New York, NY, American Society of Mechanical Engineers, 1-7 (1963).
364. Hirsch, A.E., Ommaya, A.K. Protection of the Brain from Injury During Impact: Experimental Studies in the Biomechanics of Head Injury. IN: Linear Acceleration of Impact Type, Neuilly-sur-Seine, Advisory Group for Aerospace Research and Development, AGARD-CP-88-71, 7-1-7-19.
365. Hirsch, A.E., Ommaya, A.K. Tolerances for Cerebral Concussion from Head Impact and Whiplash in Primates. *J Biomech*, 4(1): 13-21 (1971 January).
366. Hobbs, C.A., Langdon, M.G. Thoracic Impact and Injury in Side Impact Accidents. Proceedings of the 1988 International Conference On the Biomechanics of Impacts, Bergisch-Gladbach, Germany, September 14-16, 1988. Bron, France, IRCOBI, 345-360 (1988).
367. Hobbs, M.A.A. High-speed, Low-level Flight Survival On Ejection. IN: High-Speed, Low-Level Flight. Neuilly-sur-Seine, France, Advisory Group for Aerospace Research and Development (AGARD), 26-1-26-3 (March 1980).
368. Hodgson, V.R. Improving Head Crash Protection. Proceedings of the 21st Annual Symposium of the Survival and Flight Equipment Association, San Antonio, TX, November 5-8, 1983. Van Nuys, CA, SAFE Association, 157-160 (1984).
369. Hodgson, V.R. Tolerance of the Head and Neck to -Gx Inertial Loading of the Head. Technical Report. Arlington, VA, U.S. Department of the Navy, Office of Naval Research, 1981.
370. Hodgson, V.R., Mason, M.W., Thomas, L.M. Head Model for Impact. Proceedings of the 16th Stapp Car Crash Conference, Detroit, MI, November 8-10, 1972, (Society of Automotive Engineers Proceedings No. P-45). New York, NY, Society of Automotive Engineers, 1-13 (1972).
371. Hodgson, V.R., Thomas, L.M. Breaking Strength of the Human Skull Vs. Impact Surface Curvature. Final Report June 30, 1970-June 30, 1971. Washington, D.C., U.S. Department of Transportation, National Highway Traffic Safety Administration, 1971.
372. Hodgson, V.R., Thomas, L.M. Breaking Strength of the Human Skull Vs. Impact Surface Curvature. Final Report. Washington, D.C., U.S. Department of Transportation, National Highway Traffic Safety Administration, DOT-HS-146-2-230, November 1973.

373. **Hodgson, V.R., Thomas, L.M. Comparison of Head Acceleration Injury Indices in Cadaver Skull Fracture. Proceedings of the 15th Stapp Car Crash Conference, Coronado, CA, November 17-19, 1971, (Society of Automotive Engineers Proceedings No. P-39). New York, NY, Society of Automotive Engineers, 169-187 (1971).**
374. **Hodgson, V.R., Thomas, L.M., Brinn, J. Concussion Levels Determined by HPR Windshield Impacts. Proceedings of the 17th Stapp Car Crash Conference, Oklahoma City, OK, November 12-13, 1973, (Society of Automotive Engineers Proceedings No. P-51). New York, NY, Society of Automotive Engineers, 171-190 (1973).**
375. **Hodgson, V.R., Thomas, L.M. Effect of Long-duration Impact On Head. Proceedings of the 15th Stapp Car Crash Conference, Detroit, MI, November 8-10, 1972, (Society of Automotive Engineers Proceedings No. P-45). New York, NY, Society of Automotive Engineers, 292-95 (1972).**
376. **Hodgson, V.R., Thomas, L.M., Greenberg, S.W., Brinn, J. Fracture Behavior of the Skull Frontal Bone Against Cylindrical Surfaces. Proceedings of the 14th Stapp Car Crash Conference, Ann Arbor, MI, November 17-18, 1970, (Society of Automotive Engineers Proceedings No. P-33). New York, NY, Society of Automotive Engineers, 341-55 (1970).**
377. **Hodgson, V.R., Thomas, L.M. Head Injury Tolerance (For Face, Skull and Brain). IN: Aircraft Crashworthiness, Saczalski, Kenneth, Singley, George T. 3d, Pilkey, Walter D. And Huston, Ronald L., Eds. (Proceedings of a Symposium, Cincinnati, OH, October 6-8, 1975). Charlottesville, VA, University Press of Virginia, 175-193 (1975).**
378. **Hodgson, V.R., Thomas, L.M. Mechanisms of Cervical Spine Injury During Impact to the Protected Head. Proceedings of the 24th Stapp Car Crash Conference, Troy, MI, October 15-18, 1980, (Society of Automotive Engineers Proceedings No. P-88). Warrendale, PA, Society of Automotive Engineers, 17-42 (1980).**
379. **Hodgson, V.R., Thomas, L.M. Mechanisms of Cervical Spine Injury During Impact to the Protected Head. (TR-12), March 9, 1981.**
380. **Hodgson, V.R., Thomas, L.M., Prasad, P. Testing the Validity and Limitations of the Severity Index. Proceedings of the 14th Stapp Car Crash Conference, Ann Arbor, MI, November 17-18, 1970, (Society of Automotive Engineers Proceedings No. P-33). Warrendale, PA, Society of Automotive Engineers, 169-87 (1970).**

381. Hoen, T.G., Wismans, J.S. Preliminary Development—Head-Neck Simulator. Volume 2: Mathematical Simulations. Final Report September 1982-October 1984. Washington, D.C., U.S. Department of Transportation, National Highway Traffic Safety Administration. DOT-HS-807-035, August 1986.
382. Hohl, M. Soft-tissue Injuries of the Neck in Automobile Accidents. Factors Influencing Prognosis. *J Bone Joint Surg [Am]*, 56A(8), 1675-82 (1974 Dec).
383. Holcomb, G.A., Huheey, M. Minimal Compression Fracture in Humans as Result of Impact During B-58 Escape Capsule Tests. Stanley Aviation Corporation, 1961.
384. Horak, J., Nilsson, B.E. Epidemiology of Fracture of the Upper End of the Humerus. *Clin Orthop*, (112), 250-3 (1975 Oct).
385. Horne, J.G., Tanzer, T.L. Olecranon Fractures: a Review of 100 Cases. *J Trauma*, 21(6), 469-72 (1981 Jun).
386. Horner, J.L., Ofsevit, D.S., Plank, G.R., Lawrence, G.G. Occupant Motion Sensors: Methods of Detection and Analysis. Washington, D.C., U.S. Department of Transportation, National Highway Traffic Safety Administration. HS-820 303, July 1971.
387. Horner, T.W., Hawker, F.W. A Statistical Study of Grip Retention Force. Final Report June 30, 1971-March 2, 1973. AMRL-TR-72-110, May 1973.
388. Horsch, J.D., Schneider, D. Biofidelity of the Hybrid III Thorax in High-velocity Frontal Impact. IN: Automatic Occupant Protection Systems, (Society of Automotive Engineers Proceedings No. SP-736). Warrendale, PA, Society of Automotive Engineers, 115-22 (1988).
389. Hosey, R.R. A Homeomorphic Finite Element Model of Impact Head Injury [Ph.D. Thesis]. New Orleans, LA, Tulane University, 1981.
390. Hoyt, K.S. Chest Trauma. *Nursing*, 13(5), 34-41 (1983 May).
391. Hubbard, D.D. Fractures of the Dorsal and Lumbar Spine. *Orthop Clin North Am*, 7(3), 605-14 (1976 Jul).
392. Hubbard, R.P., McLeod, D.G. A Basis for Crash Dummy Skull and Head Geometry. IN: King, William F. And Mertz, Harold J., Eds. Human Impact Response: Measurement and Simulation. New York, NY, Plenum Press, 129-152 (1973).

393. Hubbard, R.P., McLeod, D.G. Definition and Development of a Crash Dummy Head. Proceedings of the 18th Stapp Car Crash Conference, Ann Arbor, MI, December 4-5, 1974, (Society of Automotive Engineers Proceedings No. P-56). Warrendale, PA, Society of Automotive Engineers, 599-628 (1974).
394. Hue, B., Tarriere, C., Leung, Y.C., Fayon, A., Got, C., Patel, A. Injury Criteria in Lateral Collisions, When an APROD Dummy is Used. Proceedings of the 9th International Technical Conference On Experimental Safety Vehicles, Kyoto, Japan, November 1-4, 1982. Washington, D.C., U.S. Department of Transportation, National Highway Traffic Safety Administration, 314-20 (1982).
395. Huelke, D.F., Chewning, W.A. Comparison of Occupant Injuries with and Without Seat Belts. Presented at the International Automotive Engineering Congress, Detroit, MI, January 13-17, 1969, (Society of Automotive Engineers Technical Paper No. 690244). New York, NY, Society of Automotive Engineers, 1-12 (1969).
396. Huelke, D.F., Lawson, T.E. Lower Torso Injuries and Automobile Seat Belts. Presented at the Automotive Engineering Congress and Exposition, Detroit, MI, February 23-27, 1976, (Society of Automotive Engineers Technical Paper No. 760370). Warrendale, PA, Society of Automotive Engineers, 1976.
397. Huelke, D.F., Nusholtz, G.S. Cervical Spine Biomechanics: a Review of the Literature. J Orthop Res, 4(2), 232-45 (1986).
398. The Human Neck: Anatomy, Injury Mechanisms and Biomechanics, (Society of Automotive Engineers Publication No. SP-438). Warrendale, PA, Society of Automotive Engineers, 1979.
399. Huston, J.C. A Comprehensive Analysis of Head and Neck Dynamics Arising from Impact and Inertial Forces. [Ph.D. Thesis]. Morgantown, WV, West Virginia University, 1975.
400. **Huston, R.L., Passerello, C.E., Harlow, M.W., Winget, J.M. The UCIN 3-D Aircraft-occupant [Three-dimensional Computer Model of Automotive Restraint Systems]. IN: Aircraft Crashworthiness, Saczalski, Kenneth, Singley, George T. 3d, Pilkey, Walter D. And Huston, Ronald L., Eds. (Proceedings of a Symposium, Cincinnati, OH, October 6-8, 1975). Charlottesville, VA, University Press of Virginia, 311-24 (1975).**
401. Huston, R.L., Winget, J.M., Harlow, M.W. Biodynamic Model of a Parachutist. Aviat Space Environ Med, 48(Sect. II), 178-182 (1978 Jan).

402. Irwin, A.L., Pricopio, L.A., Mertz, H.J., Balser, J.S., Chkoreff, W.M. Comparison of the EUROSID and SID Impact Responses to the Response Corridors of the International Standards Organization. IN: Side Impact: Injury Causation and Occupant Protection, (Society of Automotive Engineers Proceedings No. SP-769). Warrendale, PA, Society of Automotive Engineers, 103-31 (1989).
403. Isler, B. Lumbosacral Lesions Associated with Pelvic Ring Injuries. J Orthop Trauma, 4(1), 1-6 (1990).
404. Italiano, P. Vertebral Fractures in Pilots Involved in Helicopter Accidents. Translated into English from Riv. Med. Aeronaut. Spaz. (Italy), 29(4), 577-602 (1966).
405. Janssen, E.G., Versmissen, A.C. Biofidelity of the European Side Impact Dummy EUROSID. Proceedings of the 32nd Stapp Car Crash Conference, Atlanta, GA, October 17-19, 1988, (Society of Automotive Engineers Proceedings No. P-215). Warrendale, PA, Society of Automotive Engineers, 101-24 (1988).
406. Janssen, E.G., Wismans, J., De Coo, P.J. Comparison of EUROSID and Cadaver Responses in Side Impacts. Proceedings of the 12th International Technical Conference On Experimental Safety Vehicles, Goteborg, Sweden, May 29-June 1, 1989. Washington, D.C., U.S. Department of Transportation, National Highway Traffic Safety Administration, 726-43 (1989).
407. Jeffery, C.C. Spontaneous Fractures of the Femoral Neck. Orthop Clin North Am, 5(4), 713-27 (1974 Oct).
408. Jenkins, N.H. The Unstable Colles' Fracture. J Hand Surg [Br], 14(2), 149-54 (1989 May).
409. Jewell, J. 21 Years of Ejection Experience—1949-1970: Martin-Baker Ejection Seats. IN: Proceedings of the 9th Annual Symposium of the Survival and Flight Equipment Association, Las Vegas, NV, September 27-30, 1971. Van Nuys, CA, SAFE Association, 19-26 (1972).
410. Joensen, H.D., Joensen, H.D. Aircraft Accident in the Faroe Islands in 1970: Observations from a Medical Point of View, with Special Reference to Spinal Fractures. Aersp Med, 43(6), 665-70 (1972 Jun).
411. Johnson, A.K. Analysis of Angular Misalignment Errors in Mounting Linear Accelerometers to Anatomical Subjects. Washington, D.C., U.S. Department of Transportation. DOT-HS-802610, October 1977.

412. Jones, I.S., Mohan, D. Head Impact Tolerance: Correlation Between Dummy Impacts and Actual Head Injuries. Washington, D.C., Insurance Institute for Highway Safety, May 1984.
413. Jones, W.L. Current Status in Aerospace Medicine. Neuilly-sur-Seine, France, Advisory Group for Aerospace Research and Development. AGARD-CP-110-73, February 1973.
414. Jones, W.L. Escape Problems and Manoeuvres in Combat Aircraft. Neuilly-sur-Seine, France, Advisory Group for Aerospace Research and Development. AGARD-CP-134, February 1974.
415. Jonsson, H., Karrholm, J., Elmqvist, L.G. Kinematics of Active Knee Extension After Tear of the Anterior Cruciate Ligament. Am J Sports Med, 17(6), 796-802 (1989 Nov-Dec).
416. Kahane, C.J. An Evaluation of Head Restraints: Federal Motor Vehicle Safety Standard 202. Washington, D.C., U.S. Department of Transportation, National Highway Traffic Safety Administration, February 1982.
417. Kaleps, I., Whitestone, J. Hybrid III Geometrical and Inertial Properties. Presented at the International Congress & Exposition, Detroit, MI, February 29-March 4, 1988, (Society of Automotive Engineers Technical Paper No. 880638). Warrendale, PA, Society of Automotive Engineers, 1-21 (1988).
418. Kallieris, D., Mellander, H., Schmidt, G., Barz, J., Mattern, R. Comparison Between Frontal Impact Tests with Cadavers and Dummies in a Simulated True Car Restrained Environment. Proceedings of the 26th Stapp Car Crash Conference, Ann Arbor, MI, October 20-21, 1982, (Society of Automotive Engineers Proceedings No. P-113). Warrendale, PA, Society of Automotive Engineers, 353-63 (1982).
419. Kallieris, D., Mattern, R., Miltner, E., Schmidt, G., Stein, K. Considerations for a Neck Injury Criterion. Proceedings of the 35th Stapp Car Crash Conference, San Diego, CA, November 18-20, 1991 (Society of Automotive Engineers Technical Paper No. 912916). Warrendale, PA, Society of Automotive Engineers, 401-11 (1991).
420. Kallieris, D., Schmidt, G. Neck Response and Injury Assessment Using Cadavers and the US-SID for Far-Side Lateral Impacts of Rear Seat Occupants with Inboard-Anchored Shoulder Belts. Proceedings of the 34th Stapp Car Crash Conference, Orlando, FL, November 4-7, 1990, (Society of Automotive Engineers Proceedings No. P-236). Warrendale, PA, Society of Automotive Engineers, 93-100 (1990).

421. Kanda, R., Nakamura, N., Sekino, H., Sakai, H., Masuzawa, H., Mii, K., Aoyagi, N., Aruga, T., Kono, H., Sugimori, T., Sugiura, M., Mori, N., Kikuchi, A., Ono, K., Kobayashi, H. Experimental Head Injury in Monkeys—Concussion and Its Tolerance Level. *Neurol Med Chir (Tokyo)*, 21(7), 645-56 (1981 Jul).
422. Kaplan, B.H. Evaluation of the Grumman MK-J5D Ejection Seat with Respect to Spinal Alignment. USAARL Report No. 72-10, February 1972.
423. Kaplan, B.H. Method of Determining Spinal Alignment and Level of Probable Fracture During Static Evaluation of Ejection Seats. *Aerosp Med*, 45(8), 942-4 (1974 Aug).
424. Kaukonen, J.P., Karaharju, E.O., Porras, M., Luthje, P., Jakobsson, A. Functional Recovery After Fractures of the Distal Forearm. Analysis of Radiographic and Other Factors Affecting the Outcome. *Ann Chir Gynaecol*, 77(1), 27-31 (1988).
425. Kaukonen, J.P., Porras, M., Karaharju, E. Anatomical Results After Distal Forearm Fractures. *Ann Chir Gynaecol*. 77(1), 21-6 (1988).
426. Kaye, J.J., Nance, E.P. JK. Cervical Spine Trauma. *Orthop Clin North Am*, 21(3), 449-62 (1990 Jul).
427. Kazarian, L.E. The Classification of Spinal Column Deformities Resulting from Aircraft Ejection Forces. AFAMRL-TR-80-38, April 17, 1980.
428. Kazarian, L.E. The F/FB-111 Escape Injury Mechanism Assessment Report for October 1967-June 1977. AMRL-TR-77-60, October 1977.
429. Kazarian, L.E. Identification and Classification of Vertebral Fractures Following Emergency Capsule Egress from Military Aircraft. *Aviat Space Environ Med*, 49(1 Pt. 2), 150-7 (1978 Jan).
430. Kazarian, L.E. Injuries to the Human Spinal Column: Biomechanics and Injury Classification. *Exerc Sport Sci Rev*, 9, 297-352 (1981).
431. Kazarian, L.E. The Primate as a Model for Crash Injury. Proceedings of the 19th Stapp Car Crash Conference, San Diego, CA, November 17-19, 1975, (Society of Automotive Engineers Proceedings No. P-62). Warrendale, PA, Society of Automotive Engineers, 931-63 (1975).
432. Kazarian, L.E. Standardization and Interpretation of Spinal Injury Criteria and Human Impact Acceleration Tolerance. Technical Report. AMRL-TR-75-85, April 1978.

433. Kazarian, L.E., Beers, K., Hernandez, J. Spinal Injuries in the F/FB-111 Crew Escape System. *Aviat Space Environ Med*, 50(9), 948-57 (1979 Sep).
434. Kazarian, L.E., Belk, W.F., Hoffman, H.P. Traumatic Lesions of the Cervical Spine 1971—1979: Incidence-severity and Classification. IN: *Aircrew Safety and Survivability (Ltd. To Combat Aircraft)*. Neuilly-sur-Seine, France, Advisory Group for Aerospace Research and Development. AGARD-CP-286, A13.1-A13.13, October 1980.
435. **Kazarian, L.E., Toth, D.N., Jonopoulos, M.W. A Review of Fatality, Impairment of Consciousness, and Head/neck Injury On USAF Ejections 1971-July 1983. IN: Report of the Working Group On the Clinical and Biomedical Evaluation of Trauma and Fatalities Associated with Aircraft Ejection and Crash (AGARD Advisory Report No. 194). Neuilly-sur-Seine, France, Advisory Group for Aerospace Research and Development. AGARD-AR-194, 17-21 (December 1984).**
436. Kazarian, L.E., Von Gierke, H.E. Age and Exercise as Factors Influencing Osteoporosis, Bone Strength, and Acceleration Tolerance [Investigated Using Rhesus Monkeys]. IN: *Adaptation and Acclimatisation in Aerospace Medicine*, Neuilly-sur-Seine, France, Advisory Group On Aerospace Research and Development AGARD-CP-82-71, 8.1-8.19 (1971).
437. Kazarian, L.E., Von Gierke, H.E. The Validation of Biodynamic Models. AMRL-TR-78-105. November 1978.
438. Kenner, V.H., Goldsmith, W. Impact On a Simple Physical Model of the Head. *J Biomech*, 6, 1-11 (1973).
439. **Kessler, J. Pedestrian Head Injuries: Reconstruction and Analysis. Presented at the Annual Winter Meeting of the American Society of Mechanical Engineers, Boston, MA, December 13-18, 1987, (87-WA/SAF-2). New York, NY, American Society of Mechanical Engineers, 1-10 (1987).**
440. Khader, G.A., Huston, R.L. Analysis of Opening Shock On a Chest Mounted Reserve Parachute. Presented at the Medical Devices and Sporting Equipment Design Automation Conference, Columbus, OH, October 5-8, 1986. New York, NY, American Society of Mechanical Engineers, 11 (1986).
441. **Khalil, T.B., Smith, D.L., Viano, D.C. Experimental Analysis of the Vibrational Characteristics of the Human Skull. *J Sound Vibration*, 63(3), 351-376, (1979 Apr 8).**

442. Khalil, T.B., Viano, D.C. Critical Issues in Finite Element Modeling of Head Impact. Proceedings of the 26th Stapp Car Crash Conference, Ann Arbor, MI, October 20-21, 1982, (Society of Automotive Engineers Proceedings No. P-113). Warrendale, PA, Society of Automotive Engineers, 87-102 (1982).
443. Kidd, E.A., Walsh, M.J. Effectiveness of ATDs and Cadavers in Evaluation of Restraint Systems. Proceedings of the 6th International Technical Conference On Experimental Safety Vehicles, Washington, D.C., October 12-15, 1976. Washington, D.C., U.S. Department of Transportation, National Highway Traffic Safety Administration, 349-63 (1976).
444. Kiel, F.W., Halstead, J.R., Townsend, F.M. Use of the Bear to Test an Aircraft Ejection Capsule. Am J Vet Res, 25, 186-191 (1964 Jan).
445. Kikuchi, A., Ono, K., Nakamura, N. Human Head Tolerance to Lateral Impact Deduced from Experimental Head Injuries Using Primates. Proceedings of the 9th International Technical Conference On Experimental Safety Vehicles, Kyoto, Japan, November 1-4, 1982. Washington, D.C., U.S. Department of Transportation, National Highway Traffic Safety Administration, 251-61 (1982).
446. King, A.I. Injury Study of the Femur-Pelvic Complex in Automobile Crash Environment. Final Report September 30, 1977-July 31, 1984. Washington, D.C., U.S. Department of Transportation, National Highway Traffic Safety Administration. DOT-HS-807-092, February 1987.
447. King, A.I. Regional Tolerance to Impact Acceleration. Presented at the General Aviation Aircraft Meeting & Exposition, Wichita, KS, April 16-19, 1985, (Society of Automotive Engineers Technical Paper No. 850852). Warrendale, PA, Society of Automotive Engineers, 29-37 (1985).
448. King, A.I., Nakamura, G.S., Vulcan, A.P. Effects of Bending On the Vertebral Column During +Gz Acceleration. Aerospace Med, 41, 294-300 (1970 Mar).
449. King, A.I., Nakhala, S.S., Mital, N.K. Simulation of Head and Neck Response to -Gx and +Gz Impacts. IN: Models and Analogues for the Evaluation of Human Biodynamic Response, Performance and Protection, an AGARD Conference. Neuilly-sur-Seine, France, Advisory Group for Aerospace Research and Development. AGARD-CP-253, A7-1-A7-13 (June).
450. King, A.I., Nakhla, S.S., Mital, N.K. Tolerance of the Neck to Indirect Impact. N00014-75-C-1015; TR-10, March 1979.
451. King, A.I., Prasad, P., Ewing, C.L. Mechanism of Spinal Injury Due to Caudocephalad Acceleration. Orthop Clin North Am, 6(1), 19-31 (1975 Jan).

452. King, A.I., Prasad, P., Ewing, C.L. Structural Considerations of the Human Vertebral Column Under +Gz Impact Acceleration. *J Aircraft*, 9(1), 84-90 (1972 Jan).
453. King, A.I., Vulcan, A.P. Elastic Deformation Characteristics of the Spine. *J Biomech*, 4(5), 413-29 (1971 Oct).
454. King, J.H. Evaluating Head-protecting Devices [Helmets Effectiveness Evaluation from Acceleration and Impact Tests, Discussing Test Criteria and Civilian and Military Standards]. Proceedings of the 19th Annual Technical Meeting of the Institute of Environmental Sciences On Realism in Environmental Testing and Control, Anaheim, CA, April 2-5, 1973. Mount Prospect, IL, Institute of Environmental Sciences, 87-96 (1973).
455. King, J.J., Fan, W.R., Vargovick, R.J. Femur Load Injury Criteria—a Realistic Approach. Proceedings of the 17th Stapp Car Crash Conference, Oklahoma City, OK, November 12-13, 1973. (Society of Automotive Engineers Proceedings No. P-51). Warrendale, PA, Society of Automotive Engineers, 509-24 (1973).
456. Kingsbury, H.B., Moore, C.G., Rohr, P.R. Relationships Between Motorcycle Helmet Structure and Head Injury Criteria. Presented at 1980 Advances in Bioengineering, the Annual Winter Meeting of the American Society of Mechanical Engineers, Chicago, IL, November 16-21, 1980. New York, NY, American Society of Mechanical Engineers, 121-124 (1980).
457. Kinneman, R.E. Jr., Every, M.G., Parker, J.F. Jr. Specific Biomedical Issues in the Escape Phase of Air Combat Mishaps During Southeast Asia Operations. IN: Escape Problems and Maneuvres in Combat Aircraft. Neuilly-sur-Seine, France, Advisory Group for Aerospace Research and Development (AGARD-CP-134): A1-1-A1-7 (February 1974).
458. Knapp, S.C., McCahan, G.R. Jr. Parachuting Impact Injuries at High Drop-zone Elevations: Environmental Effects. IN: Linear Acceleration of Impact Type. Neuilly-sur-Seine, France, Advisory Group for Aerospace Research and Development (AGARD-CP-88-71), 17-1-17-9 (June 1971).
459. Koman, L.A., Mooney, J.F.3d, Poehling, G.C. Fractures and Ligamentous Injuries of the Wrist. *Hand Clin*, 6(3), 477-91 (1990 Aug).
460. Kornhauser, M. Biodynamic Modeling and Scaling: Anthropomorphic Dummies, Animals and Man. AMRL-TR-71-29, December 1971.
461. Korres, D.S., Kyritsis, G., Kouvaras, J., Sapkas, G., Velikas, E.P. Double Level Fractures of the Cervical Spine. *Int Orthop*, 11(2), 105-8 (1987).

462. **Kramer, M., Burow, K., Heger, A. Fracture Mechanism of Lower Legs Under Impact Load. Proceedings of the 17th Stapp Car Crash Conference, Oklahoma City, OK, November 12-13, 1973, (Society of Automotive Engineers Proceedings No. P-51). Warrendale, PA, Society of Automotive Engineers, 81-100 (1973).**
463. **Krause, H.E., Shirazi, M. The Transverse Response of the Lumbar Spine Under Longitudinal Loads. AMRL-TR-71-29, Paper 24, December 1971.**
464. **Kreff, S. Cardiac Injuries in Aircraft Occupants Resulting from Aircraft Accidents. Aviat Space Environ Med, 46(11), 1395-402 (1975 Nov).**
465. **Kroell, C.K. Thoracic Response to Blunt Frontal Loading. IN: the Human Thorax: Anatomy, Injury, and Biomechanics (A Continuing Education Course Developed by SAE Automobile Body Activity-Passenger Protection Committee). Warrendale, PA, Society of Automotive Engineers, 49-77 (1976).**
466. **Kroell, C.K., Allen, S.D., Warner, C.Y., Perl, T.R. Interrelationship of Velocity and Chest Compression in Blunt Thoracic Impact to Swine II. Proceedings of the 30th Stapp Car Crash Conference, San Diego, CA, October 27-29, 1986, (Society of Automotive Engineers Proceedings No. P-189). Warrendale, PA, Society of Automotive Engineers, 99-121 (1986).**
467. **Kroell, C.K., Pope, M.E., Viano, D.C., Warner, C.Y., Allen, S.D. Interrelationship of Velocity and Chest Compression in Blunt Thoracic Impact to Swine. Proceedings of the 25th Stapp Car Crash Conference, San Francisco, CA, September 28-30, 1981, (Society of Automotive Engineers Proceedings No. P-97). Warrendale, PA, Society of Automotive Engineers, 549-79 (1981).**
468. **Kroell, C.K., Schneider, D.C., Nahum, A.M. Impact Tolerance and Response of the Human Thorax. Proceedings of the 15th Stapp Car Crash Conference, Coronado, CA, November 17-19, 1971, (Society of Automotive Engineers Proceedings No. P-39). New York, NY, Society of Automotive Engineers, 84-134 (1971).**
469. **Kroell, C.K., Schneider, D.C., Nahum, A.M. Impact Tolerance and Response of the Human Thorax II. Proceedings of the 18th Stapp Car Crash Conference, Ann Arbor, MI, December 4-5, 1974, (Society of Automotive Engineers Proceedings No. P-56). Warrendale, PA, Society of Automotive Engineers, 383-457 (1974).**
470. **Laananen, D.H. Aircraft Crash Survival Design Guide. Volume II. Aircraft Crash Environment and Human Tolerance. USARTL-TR-79-22B, 1980.**
471. **Lafferty, J.F. Dynamic Response of Vertebral Elements Related to USAF Injury. Final Report, 1 Jan.-31 Dec. 1977. August 1978.**

472. Langdon, M.G. Modelling the Lateral Impact of the Thorax in Car Side Impact Accidents. Proceedings of the 10th International Technical Conference On Experimental Safety Vehicles, Oxford, England, July 1-4, 1985. Washington, D.C., U.S. Department of Transportation, National Highway Traffic Safety Administration, 114-24 (1985).
473. Lange, W. Mechanical and Physiological Response of the Human Cervical Vertebral Column to Severe Impacts Applied to the Torso, (Paper 5). Presented at the Symposium On Biodynamic Models and Their Applications, Dayton, OH, 26-28, Oct 1970, 141-167 (1970).
474. Langwieder, K., Danner, M., Schmelzing, W., Appel, H., Kramer, F., Hofmann, J. Comparison of Passenger Injuries in Frontal Car Collisions with Dummy Loadings in Equivalent Simulations. Proceedings of the 23rd Stapp Car Crash Conference, San Diego, CA, October 17-19, 1979, (Society of Automotive Engineers Proceedings No. P-82). Warrendale, PA, Society of Automotive Engineers, 201-231 (1979).
475. Lau, I.V., Viano, D.C., Culver, C.C., Jedrzejczak, E. Design of a Modified Chest for EUROSID Providing Biofidelity and Injury Assessment. IN: Side Impact: Injury Causation and Occupant Protection, (Society of Automotive Engineers Proceedings No. SP-769). Warrendale, PA, Society of Automotive Engineers, 163-71 (1989).
476. Lau, I.V., Viano, D.C. The Viscous Criterion—Bases and Applications of an Injury Severity Index for Soft Tissues. Proceedings of the 30th Stapp Car Crash Conference, San Diego, CA, October 27-29, 1986, (Society of Automotive Engineers Proceedings No. P-189). Warrendale, PA, Society of Automotive Engineers, 123-42 (1986).
477. Laughlin, D.R. A Magnetohydrodynamic Angular Motion Sensor for Anthropomorphic Test Device Instrumentation. Proceedings of the 33rd Stapp Car Crash Conference, Washington, D.C., October 4-6, 1989, (Society of Automotive Engineers Proceedings No. P-227). Warrendale, PA, Society of Automotive Engineers, 43-77 (1989).
478. Leberte, M., Dabezies, E. Pelvic Fractures. Orthopedics, 8(1), 120-3 (1985 Jan).
479. Lee, Y.C., Advani, S.H. Transient Response of a Sphere to Torsional Loading—a Head Injury Model. Math Biosci, 6, 473-86 (1970).
480. Leger, A., Delahaye, R.P. Parachuting. IN: Physiopathology and Pathology of Spinal Injuries in Aerospace Medicine. Neuilly-sur-Seine, France, Advisory Group for Aerospace Research and Development. AGARD-AG-250-(ENG)-2ND, February 1982.

481. Lenox, J.B., Stalnaker, R.L., White, C.D., Moore, G.T., Anderson, O.M., Schleicher, R.R., Peel, H.H., Martin, S.S., Driscoll, G.D., Huntington, H.W., Carey, K.D., Haffner, M.P., Ommaya, A.K. Development of Neck Injury Tolerance Criteria in Human Surrogates Static Tensile Loading in the Baboon Neck Preliminary Observations. Proceedings of the 9th International Technical Conference on Experimental Safety Vehicles, Kyoto, Japan, November 1-4, 1982. Washington, D.C., U.S. Department of Transportation, National Highway Traffic Safety Administration, 279-86 (1982).
482. Lenox, J.B., Stalnaker, R.L., White, C.D., Moore, G.T., Anderson, O.M., Schleicher, R.R., Peel, H.H., Martin, S.S., Driscoll, G.D., Huntington, H.W., Carey, K.D., Haffner, M.P., Ommaya, A.K. Interpretation of Neck Loads Transduced by Advanced Anthropometric Test Dummies. I. Biomechanical Data, Presented at Biomedical Engineering II: Recent Developments, Proceedings of the 2nd Southern Biomedical Engineering Conference, San Antonio, TX, September 26-27, 1983. New York, NY, Pergamon Press, 214-217 (1983).
483. Lestrelin, D., Tarriere, C., Walfisch, G., Fayon, A., Got, C., Patel, A., Hureau, J. Proper Use of HIC Under Different Typical Collision Environments. Proceedings of the 9th International Technical Conference on Experimental Safety Vehicles, Kyoto, Japan, November 1-4, 1982. Washington, D.C., U.S. Department of Transportation, National Highway Traffic Safety Administration, 321-36 (1982).
484. Leung, Y.C., Hue, B., Fayon, A., Tarriere, C., Hamon, H., Got, C., Patel, A., Hureau, J. Study of "Knee-Thigh-Hip" Protection Criterion. Proceedings of the 27th Stapp Car Crash Conference, San Diego, CA, October 17-19, 1983, (Society of Automotive Engineers Proceedings No. P-134). Warrendale, PA, Society of Automotive Engineers, 351-64 (1983).
485. Levin, L.A., Andersen, H.T., Kazarian, L.E., Hayes, P., Sverdrup, H.U. Data Analysis in Cervical Trauma. IN: Neck Injury in Advanced Military Aircraft. Neuilly-sur-Seine, France, Advisory Group for Aerospace Research and Development. AGARD-CP-471, 5-1-5-5 (February 1990).
486. Lewis, S.T. Ejection Injuries in Southeast Asia Prisoner of War Returnees. Presented at the 12th Annual Symposium of the Flight and Safety Equipment Association, Las Vegas, NV, September 8-12, 1974. Canoga Park, CA, SAFE Association, (1974).
487. Lewis, S.L., Pozo, J.L., Muirhead-Allwood, W.F. Coronal Fractures of the Lateral Femoral Condyle. J Bone Joint Surg [Br], 71(1), 118-20 (1989 Jan).
488. Li, T.F., Advani, S.H., Lee, Y.C. The Effect of Initial Curvature on the Dynamic Response of the Spine to Axial Acceleration. December 1971.

489. Lighthall, J.W., Dixon, C.E., Anderson, T.E. Experimental Models of Brain Injury. *J Neurotrauma*, 6(2), 83-97 (1989).
490. Lighthall, J.W., Melvin, J.W., Ueno, K. Toward a Biomechanical Criterion for Functional Brain Injury. Proceedings of the 12th International Technical Conference on Experimental Safety Vehicles, Goteborg, Sweden, May 29-June 1, 1989. Washington, D.C., U.S. Department of Transportation, National Highway Traffic Safety Administration, 627-633 (1989).
491. Limbrey, B. Post-ejection Survival. Proceedings of the 18th Annual Symposium of the Survival and Flight Equipment Association, San Diego, CA, October 12-16, 1980. Canoga Park, CA, SAFE Association, 235-238 (1981).
492. Lin, H.Y., Wiechel, J.F., Guenther, D.A. Empirical Injury Prediction of the Pedestrian Thorax. IN: Pedestrian Impact Injury and Assessment, (Society of Automotive Engineers Publication No. P-121). Warrendale, PA, Society of Automotive Engineers, 179-189 (1983).
493. Lindgren, S.O. Experimental Studies of Mechanical Effects in Head Injury. *Acta Chir Scand Suppl*, 360, 1-100 (1966).
494. Linear Acceleration of Impact Type. Neuilly-sur-Seine, France, Advisory Group for Aerospace Research and Development. AGARD-CP-88-71, December 1971.
495. Lipka, J.M., Saha, S., Keating, E.M., Albright, J.A. Biomechanical Analysis of a Simulated Spondylolysis Fracture and Its Contribution to Lumbar Spine Rigidity. Abstract of a paper presented at the 5th Southern Biomedical Engineering conference on Biomaterials, Medical Devices and Artificial Organs, Shreveport, LA, October 20-21, 1986, [ABSTRACT ONLY] 148-49, (1986).
496. Lissner, H.R., Evans, F.G. Engineering Aspects of Fractures. *Clin Orthop*, 8, 310-22 (1958).
497. List of Head/neck Injury On Ejection in the German Armed Forces from 1972-1981. IN: Report on the Working Group on the Clinical and Biomedical Evaluation of Trauma and Fatalities Associated with Aircrew Ejection and Crash. Neuilly-sur-Seine, France, Advisory Group for Aerospace Research and Development (AGARD-AR-194), 6-10 (December 1984).
498. Little, R.W., Hubbard, P.R., Hyler, D.L., Slonim, A. Mechanical Properties of Spinal Ligaments for Rhesus Monkey, Baboon and Chimpanzee. AFAMRL-TR-81-40, June 1981.

499. Little, R.A., Yates, D.W., Atkins, R.E., Bithell, P., Stansfield, M. The Effects of Minor and Moderately Severe Accidental Chest Injuries On Pulmonary Function in Man. *Arch Emerg Med*, 1(1), 29-38 (1984 Mar).
500. Liu, Y.K. The Biomechanics of Spinal and Head Impact: Problems of Mathematical Simulation. (Paper 28). Presented at the Symposium on Biodynamic Models and their Applications, Dayton, OH, October 26-28, 1970. Neuilly-sur-Seine, France, Advisory Group for Aerospace Research and Development (AGARD), 701-36 (December 1971).
501. Liu, Y.K. Towards a Stress Criterion of Injury: An Example in Caudocephalad Acceleration. *J Biomech*, 2, 145-149 (1969).
502. Liu, Y.K., Krieger, K.W., Njus, G., Ueno, K., Connors, M. Cervical Spine Stiffness and Geometry of the Young Human Male. Technical Report. Wright-Patterson AFB, OH, Air Force Aerospace Medical Research Laboratory, 1982.
503. Liu, Y.K., Pontius, U.R., Hosey, R.R. The Effects of Initial Spinal Configuration on Pilot Ejection. USAARL-74-6, October 1973.
504. Liu, Y.K., Ray, G. Systems Identification Scheme for the Estimation of the Linear Viscoelastic Properties of the Intervertebral Disc. *Aviat Space Environ Med* 1978 Jan, 49(1), 175-177.
505. Lockett, F.J. Biomechanics of Head-tolerance Criteria [Impact Injuries]. NPL-DMA(A)64, April 1983.
506. Lockett, F.J. Biomechanics Justification for Empirical Head-tolerance Criteria. *J Biomech*, 18(3), 217-24 (1985).
507. Lombard, C.F., Ames, S.W., Roth, H.P., Rosenfeld, S. Voluntary Tolerance of the Human to Impact Accelerations of the Head. *J Aviat Med Suppl*, 2(6), 109-16 (1951 Dec).
508. Looser, K.G., Crombie, H.D. Jr. Pelvic Fractures: An Anatomic Guide to Severity of Injury. Review of 100 Cases. *Am J Surg*, 132(5), 638-42 (1976 Nov).
509. Lotz, J.C., Gerhart, T.N., Hayes, W.C. Mechanical Properties of Trabecular Bone from the Proximal Femur: a Quantitative CT Study. *J Comput Assist Tomogr*, 14(1), 107-14 (1990 Jan-Feb).
510. Lotz, J.C., Hayes, W.C. The Use of Quantitative Computed Tomography to Estimate Risk of Fracture of the Hip from Falls. *J Bone Joint Surg [Am]*, 72(5), 689-700 (1990 Jun).

511. Louw, J.A., Mafoyan, N.A., Small, B., Naser, C.P. Occlusion of the Vertebral Artery in Cervical Spine Dislocations. *J Bone Joint Surg [Br]*, 72(4), 679-81 (1990 Jul).
512. Love, J.W. Chest Injuries. *JAMA*, 232(4), 385-7 (1975 Apr 28).
513. Low, T.C., Stalnaker, R.L. A Lumped Parameter Approach to Simulate the Rotational Head Motion. *Proceedings of the 1987 International Conference on the Biomechanics of Impacts (IRCOBI)*, Birmingham, England, September 8-10, 1987. Bron, France, IRCOBI, 203-215 (1987).
514. Lowenhielm, P. Head Injuries—Biomechanical Principles. *Acta Neurochir Suppl (Wien)*, 36, 31-32 (1986).
515. Lowenhielm, P., Voigt, G.E., Ljung, C.B., Wihlberg, B.G. Influence of Post-mortem Changes On Experimental Safety Belt Injuries. *Z Rechtsmed*, 80(3), 171-82 (1977 Nov 18).
516. Lowne, R.W., Neilson, I.D. The Development and Certification of EUROSID. *Proceedings of the 11th International Technical Conference on Experimental Safety Vehicles*, Washington, D.C., May 12-15, 1987. Washington, D.C., U.S. Department of Transportation, National Highway Traffic Safety Administration, 363-75 (1987).
517. Lucas, W.T. Measuring Hand Forces and Wrist Motions for Preventing Injuries in the Workplace. *Proceedings of the 16th Annual Northeast Bioengineering Conference*, University Park, PA, March 26-27, 1990. Piscataway, NJ, IEEE, 143-144 (1990).
518. Luehrs, R.E., Rice, E.V. An Analysis of Fatality Causal Factors Associated with Unsuccessful Ejections in the U.S. Navy. *Proceedings of the 7th National Flight Safety Survival and Personal Equipment Symposium*, Las Vegas, NV, October 27-30, 1969. Van Nuys, CA, SAFE, 1969.
519. Mackay, G.M. Injury and Collision Severity. *Proceedings of the 12th Stapp Car Crash conferece*, Detroit, MI, October 22-23, 1968, (Society of Automotive Engineers Proceedings No. P-26). New York, NY, Society of Automotive Engineers, 207-219 (1968).
520. Mackay, G.M. Lower Limb Injuries to Riders of Motorcycles. IN: *Biomechanics and Medical Aspects of Lower Limb Injuries*, (Society of Automotive Engineers Proceedings No. P-186). Warrendale, PA, Society of Automotive Engineers, 129-35 (1986).

521. MacLaughlin, T.F., Kessler, J.W. Pedestrian Head Impact Against the Central Hood of Motor Vehicles Test Procedure and Results. Proceedings of the 34th Stapp Car Crash Conference, Orlando, FL, November 4-7, 1990, (Society of Automotive Engineers Proceedings No. P-236). Warrendale, PA, Society of Automotive Engineers, 113-121 (1990).
522. Madson, R.A. A Study of Parachute Landing Injuries and Their Relationship to Parachute Performance and Landing Conditions. Proceedings of the 13th Annual Symposium of the Survival and Flight Equipment Association, San Antonio, TX, September 21-26, 1975. Canoga Park, CA, SAFE Association, 77-80 (1975).
523. Maiman, D.J., Sances, A. Jr., Myklebust, J.B., Larson, S.J., Houterman, C., Chilbert, M., El-Ghatit, A.Z. Compression Injuries of the Cervical Spine: a Biomechanical Analysis. *Neurosurgery*, 13(3), 254-60 (1983 Sep).
524. Malach, T.J. A Preliminary Study into Methods of Estimating Physical Injury Hazards. Defense Research Establishment, Suffield, Ralston, Alberta, Canada, (Suffield Memorandum No. 115/71), December 1973.
525. Maldonado, R.J., Stork, R.L. Review of Head and Neck Injuries in Ejection Seat Equipped Aircraft from 1971 to 1980. Proceedings of the 2nd Southern Biomedical Engineering Conference, San Antonio, TX, September 26-27, 1983. New York, NY, Pergamon Press, 218-21 (1983).
526. Mansurov, A.R. X-ray Investigation in Aviation and Space Medicine. Washington, D.C., National Aeronautics and Space Administration, October 1975. Translation into English of the book "Tashkent", USSR, Meditsina Press. NASA-TT-F-804, 1-166 (1971).
527. Maquet, P., Pelzer-Bawin, G. Mechanical Analysis of Inter- and Subtrochanteric Fractures of the Femur. *Acta Orthop Belg*, 46(6), 823-8 (1980).
528. Margulies, S.S., Thibault, L.E. Analytical Model of Traumatic Diffuse Brain Injury. *J Biomech Eng, Trans ASME*, 111(3): 241-9 (1989 Aug).
529. Margulies, S.S., Thibault, L.E., Gennarelli, T.A. Physical Model Simulations of Brain Injury in the Primate. *J Biomech*, 23(8), 823-36 (1990 Aug).
530. Mason, J.K., ed. *Aerospace Pathology*. Chicago, IL, College of American Pathologists Foundation, 1973.

531. Matsuoka, F., Kumagai, K., Takahashi, H. Problem and Improvement of Hybrid III Dummy Rib Cage Features. Proceedings of the 12th International Technical Conference on Experimental Safety Vehicles, Goteborg, Sweden, May 29-June 1, 1989. Washington, D.C., U.S. Department of Transportation, National Highway Traffic Safety Administration, 660-5 (1989).
532. Mattingly, T.E., Felder, U.W., Lombard, C.F. Investigation of Vibration and Impact Protection of the Human Head and Neck. AMRL-TR-69-112, December 1969.
533. Maull, K.I., Whitley, R.E., Cardea, J.A. Vertical Deceleration Injuries. Surg Gynecol Obstet, 153(2), 233-6 (1981 Aug).
534. Mauro, C.A., Burns, K.C., Smith, D.E. Statistical Impact Acceleration Injury Prediction Models Based On -Gx Accelerator Data. State College, PA, Desmatics, Inc. Technical Report No. 126-1, October 1986.
535. Maxwell, M.H. Biodynamics Data Bank: An Overview of DB56. Proceedings of the 23rd Annual Symposium of the Survival and Flight Equipment Association, Las Vegas, NV, December 1-5, 1985. Van Nuys, CA, SAFE Association, 145-147 (1985).
536. Mazurin, Y.V., Stupakov, G.P. Predicting the Effect of Linear and Angular Impact Acceleration On Humans. In its JPRS Report: Science and Technology. USSR: Life Sciences, p 3. Transl. into ENGLISH from Kosmicheskaya Biologiya i Aviakosmicheskaya Meditsina, Moscow (USSR), 23(4), [ABSTRACT ONLY] 79-83, (Jul-Aug 1989).
537. McBroom, R.J., Hayes, W.C., Edwards, W.T., Goldberg, R.P., White, A.A. 3d. Prediction of Vertebral Body Fracture Risk Employing Noninvasive Techniques. Presented at the Winter Annual Meeting of the American Society of Mechanical Engineers, Advances in Bioengineering, Boston, MA, November 13-18, 1983. New York, NY, American Society of Mechanical Engineers, 139-140 (1983).
538. McCarthy, G.W. USAF Take-off and Landing Ejections, 1973-85. Aviat Space Environ Med, 59(4), 359-62 (1988 Apr).
539. McCoy, G.F., Johnstone, R.A., Kenwright, J. Biomechanical Aspects of Pelvic and Hip Injuries in Road Traffic Accidents. J Orthop Trauma, 3(2), 118-23 (1989).
540. McElhaney, J.H., Doherty, B.J., Paver, J.G., Myers, B.S., Grey, L. Flexion, Extension and Lateral Bending Responses of the Cervical Spine. IN: Neck Injury in Advanced Military Aircraft. Neuilly-sur-Seine, France, Advisory Group for Aerospace Research and Development. AGARD-CP-471, 10.1-10.10 (February 1990).

541. McElhaney, J.H., Doherty, B.J., Paver, J.G., Myers, B.S., Gray, L. Combined Bending and Axial Loading Responses of the Human Cervical Spine. Proceedings of the 32nd Stapp Car Crash Conference, Atlanta, GA, October 17-19, 1988. (Society of Automotive Engineers Proceedings No. P-215). Warrendale, PA, Society of Automotive Engineers, 21-8, (1988).
542. McElhaney, J.H., Mate, P.I., Roberts, V.L. A New Crash Test Device: "Repeatable Pete". Proceedings of the 17th Stapp Car Crash Conference, Oklahoma City, OK, November 12-13, 1975. (Society of Automotive Engineers Proceedings No. P-51). Warrendale, PA, Society of Automotive Engineers, 467-507 (1973).
543. McElhaney, J.H., Roberts, V.L., Hilyard, Joseph F. Handbook of Human Tolerance. Tokyo, Japan, Japan Automobile Research Institute (JARI), 1976.
544. McElhaney, J.H., Paver, J.G., McCrackin, H.J., Maxwell, G.M. Cervical Spine Compression Responses.
545. McElhaney, J.H., Roberts, V.L., Stalnaker, R.L. The Biomechanical Aspects of Crash Helmet Design. IN: Linear Acceleration of Impact Type. Neuilly-sur-Seine, France, Advisory Group for Aerospace Research and Development. AGARD-CP-88-71, D2.1-D2.8 (December 1971).
546. McElhaney, J.H., Roberts, V.L., Stalnaker, R.L. A Brain Injury Model for Crash Helmet Design. Proceedings of the 18th Annual Technical Meeting of the Institute of Environmental Sciences On Environmental Progress in Science and Education, New York, NY, May 1-4, 1972. Mount Prospect, IL, Institute of Environmental Sciences, 112-116 (1972).
547. McElhaney, J.H., Stalnaker, R., Roberts, V.L. Door Crashworthiness Criteria. Proceedings of the 15th Stapp Car Crash Conference, Coronado, CA, November 17-19, 1971, (Society of Automotive Engineers Proceedings No. P-39). New York, NY, Society of Automotive Engineers, 489-517 (1971).
548. McMeekin, R.R. Kinematics of Aircraft Occupants in Accidents: Feasibility of Computer Simulation. Aerospace Med, 45(8), 970-4 (1974).
549. McPherson, D., Oversby, M. Investigation of Injury Mechanisms in Fully Restrained Vehicle Occupants. Proceedings of the International Conference of the International Association for Accident and Traffic Medicine, 1977.
550. Mellander, H. HIC—The Head Injury Criterion. Practical Significance for the Automotive Industry. Acta Neurochir Suppl (Wien), 36, 18-20 (1986).

551. Melvin, J.W. Biomechanics of Lateral Thoracic Injury. IN: The Human Thorax: Anatomy, Injury and Biomechanics (Society of Automotive Engineers Proceedings No. SP-438). Warrendale, PA, Society of Automotive Engineers, 79-84 (1976).
552. Melvin, J.W. The Engineering Design, Development, Testing and Evaluation of an Advanced Anthropomorphic Test Device, Phase 1: Concept Definition. Executive Summary. Washington, D.C., U.S. Department of Transportation, National Highway Traffic Safety Administration. UNTRI-85-8, September 1985.
553. Melvin, J.W. Human Neck Injury Tolerance. IN: The Human Neck: Anatomy, Injury Mechanisms and Biomechanics, (Society of Automotive Engineers Publication No. SP-438). Warrendale, PA, Society of Automotive Engineers, 45-6 (1979).
554. Melvin, J.W., Evans, F.G. A Strain Energy Approach to the Mechanics of Skull Fracture. Proceedings of the 15th Stapp Car Crash Conference, Coronado, CA, November 17-19, 1971, (Society of Automotive Engineers Proceedings No. P-39). New York, NY, Society of Automotive Engineers, 666-85 (1971).
555. Melvin, J.W., Fuller, P.M., Daniel, R.P., Pavliscak, G.M. Human Head and Knee Tolerance to Localized Impacts. Presented at the Mid-Year Meeting, Chicago, IL, May 19-23, 1969, (Society of Automotive Engineers Technical Paper No. 690477). New York, NY, Society of Automotive Engineers, 1969.
556. Melvin, J.W., King, A.I., Alem, N.M. AATD System Technical Characteristics, Design Concepts and Trauma Assessment Criteria. Washington, D.C., U.S. Department of Transportation, National Highway Traffic Safety Administration, September 1985.
557. Melvin, J.W., Mohan, D., Stalnaker, R.L. Occupant Injury Assessment Criteria. (Society of Automotive Engineers Technical Paper No. 750914). Warrendale, PA, Society of Automotive Engineers, 2483-2494 (1975).
558. Melvin, J.W., Robbins, D.H., Benson, J.B. Experimental Application of Advanced Thoracic Instrumentation Techniques to Anthropomorphic Test Devices. Proceedings of the 7th International Technical Conference On Experimental Safety Vehicles, Paris, France, June 5-8, 1979. Washington, D.C., U.S. Department of Transportation, National Highway Traffic Safety Administration, 416-27 (1979).
559. Melvin, J.W., Robbins, D.H., Weber, K., Campbell, K.L., Smrcka, J. Review of Dummy Design and Use. Washington, D.C., U.S. Department of Transportation, National Highway Traffic Safety Administration. UMTRI-85-13, February 1985.

560. Melvin, J.W., Shee, T.R. Facial Injury Assessment Techniques. Proceedings of the 12th International Technical Conference On Experimental Safety Vehicles, Goteborg, Sweden, May 29-June 1, 1989. Washington, D.C., U.S. Department of Transportation, National Highway Traffic Safety Administration, 608-17 (1989).
561. Melvin, J.W., Shee, T.R. Angular Acceleration Measurement Techniques for Head Impact. Proceedings of a Conference, Head Injury Mechanisms: The Need for an Angular Acceleration Criterion, Washington, D.C., October 4, 1989. Des Plaines, IL, Association for the Advancement of Automotive Medicine, (1989).
562. Melvin, J.W., Nusholtz, G.S. Tolerance and Response of the Knee-Femur-Pelvis Complex to Axial Impact: Impact Sled Tests. Final Report. Ann Arbor, MI, University of Michigan, Highway Safety Research Institute, UM-HSRI-76-33, June 1980.
563. Melvin, J.W., Weber, K. Abdominal Intrusion Sensor for Evaluating Child Restraint Systems. IN: Passenger Comfort, Convenience and Safety: Test Tools and Procedures, (Society of Automotive Engineers Proceedings No. P-174). Warrendale, PA, Society of Automotive Engineers, 249-56 (1986).
564. Melvin, J.W., Weber, K, eds. Review of Biomechanical Impact Response and Injury in the Automotive Environment. Final Report June 1983-March 1985. Washington, D.C., U.S. Department of Transportation, National Highway Traffic Safety Administration. DOT-HS-807-042, March 1985.
565. Mentzer, S.G. Efficient Computation of Head Injury Criterion (HIC) Values. Final Report April 1, 1983-January 27, 1984. Washington, D.C., U.S. Department of Transportation, National Highway Traffic Safety Administration. DOT-HS-806-861, November 1984.
566. Mertz, H.J. Biofidelity of the Hybrid III Head. Presented at the Government/Industry Meeting and Exposition, Washington, D.C., May 20-23, 1985, (Society of Automotive Engineers Technical Paper No. 851245). Warrendale, PA, Society of Automotive Engineers, 1-9 (1985).
567. Mertz, H.J. Injury Assessment Values Used to Evaluate Hybrid III Response Measurements. Safety and Crashworthiness Systems, General Motors Corporation, February 1984.
568. Mertz, H.J., Hodgson, V.R., Thomas, L. Murray, Nyquist, G.W. An Assessment of Compressive Neck Loads Under Injury Producing Conditions. Physician Sportsmed, 6(3) 95-100, 103-4, 106 (Nov 1978)

569. Mertz, H.J., Patrick, L.M. Investigation of the Kinematics and Kinetics of Whiplash. Proceedings of the 11th Stapp Car Crash Conference, Anaheim, CA, October 10-11, 1967, (Society of Automotive Engineers Proceedings No. P-20). New York, NY, Society of Automotive Engineers, 175-206 (1967).
570. Mertz, H.J., Patrick, L.M. Strength and Response of the Human Neck. Proceedings of the 15th Stapp Car Crash Conference, Coronado, CA, November 17-19, 1971, (Society of Automotive Engineers Proceedings No. 710855). New York, NY, Society of Automotive Engineers, 207-55 (1971).
571. Metges, P.J., Anton, D.J., Kazarian, L.E. The Clinical and Radiological Assessment of Cervical Injury. IN: Report of the Working Group On the Clinical and Biomedical Evaluation of Trauma and Fatalities Associated with Aircrew Ejection and Crash. Neuilly-sur-Seine, France, Advisory Group for Aerospace Research and Development AGARD-AR-194, 34-66 (December 1984).
572. Milgrom, C., Giladi, M., Simkin, A., Rand, N., Kedem, R., Kashtan, H., Stein, M. An Analysis of the Biomechanical Mechanism of Tibial Stress Fractures Among Israeli Infantry Recruits. A Prospective Study. Clin Orthop 1988 Jun, (231), 216-21.
573. Milgrom, C., Giladi, M., Simkin, A., Rand, N., Kedem, R., Kashtan, H., Stein, M., Gomori, M. The Area Moment of Inertia of the Tibia: a Risk Factor for Stress Fractures. J Biomech 1989, 22(11/12), 1243-1248.
574. Miller, L.S., Cotler, H.B., De Lucia, F.A., Cotler, J.M., Hume, E.L. Biomechanical Analysis of Cervical Distraction. Spine 1987 Nov, 12(9), 831-7.
575. Miller, M.D., Gehweiler, J.A., Martinez, S., Charlton, O.P., Daffner, R.H. Significant New Observations On Cervical Spine Trauma. AJR Am J Roentgenol 1978 Apr, 130(4), 659-63.
576. Miyazaki, K., Kubota, M., Sakamoto, S. Load Measuring Method of Motorcyclist's Leg During Motorcycle Collision. Proceedings of the 12th International Technical Conference on Experimental Safety Vehicles, Goteborg, Sweden, May 29-June 1, 1989. Washington, D.C., U.S. Department of Transportation, National Highway Traffic Safety Administration, 1368-72, (1989).
577. Moffatt, C.A., Advani, S.H., Lin, C.J. Analytical and Experimental Investigations of Human Spine Flexure. Presented at the American Society of Mechanical Engineers Winter Annual Meeting, Washington, D.C., November 28-December 2, 1971. New York, NY, American Society of Mechanical Engineers, 1-12 (1971).

578. **Moffatt, C.A., Benedict, J.V. The Investigation of Vertebral Injury Sustained During Aircrew Ejection. Annual Technical Report, June 28, 1969-June 27, 1970. San Antonio, TX, Technology Incorporated, Life Sciences Division, 1970.**
579. **Moffatt, C.A., Mitter, E.L., Martinez, R. Pelvic Fractures Crash Vehicle Indicators. *Accid Anal Prev*, 22(6), 561-569 (1990).**
580. **Mohr, G.C., Brinkley, J.W., Kazarian, L.E., Millard, W.W. Variations of Spinal Alignment in Egress Systems and Their Effect. *Aerosp Med*, 40(9), 983-8 (1969 Sep).**
581. **Moneim, M.S., Bolger, J.T., Omer, G.E. Radiocarpal Dislocation—Classification and Rationale for Management. *Clin Orthop*, (192), 199-209 (1985 Jan-Feb).**
582. **Mooney, M.T., Collins, J.A. Abdominal Penetration Measurement Insert for the Hybrid III Dummy. IN: Passenger Comfort, Convenience and Safety, (Society of Automotive Engineers Proceedings No. P-174). Warrendale, PA, Society of Automotive Engineers, 285-89 (1986).**
583. **Morgan, R.M., Eppinger, R.H., Marcus, J.H. Human Cadaver Patella-femur-pelvis Injury Due to Dynamic Frontal Impact to the Patella. Proceedings of the 12th International Technical Conference On Experimental Safety Vehicles, Goteborg, Sweden, May 29-June 1, 1989. Washington, D.C., U.S. Department of Transportation, National Highway Traffic Safety Administration, 683-99 (1989).**
584. **Morgan, R.M., Marcus, J.H., Eppinger, R.H. Side Impact: the Biofidelity of NHTSA's Proposed ATD and Efficacy of TTI. Proceedings of the 30th Stapp Car Crash Conference, San Diego, CA, October 27-29, 1986, (Society of Automotive Engineers Proceedings No. P-189). Warrendale, PA, Society of Automotive Engineers, 27-37 (1986).**
585. **Moroney, W.F., Hughes, R.E., Spicuzza, R.J. Development of an Automated Anthropometric Data Measurement System (AADMS). Proceedings of the 28th Annual Meeting of the Human Factors Society, San Antonio, TX, October 22-26, 1984. Santa Monica, CA, Human Factors Society, 1003-1005 (1984).**
586. **Moseley, H.G. Aircraft Accident Injuries—a Review of Over 2,000 Cases. Presented at the 28th Annual Meeting of the Aerospace Medical Association, Denver, CO, May 6-8, 1957. Norton AFB, CA, Aeromedical Safety Division, 1967.**
587. **Moseley, J.D., Cook, J.E. Visceral Displacement in Black Bears Subjected to Abrupt Deceleration. *Aerospace Medicine*, 31, 1-8 (1960 Jan).**
588. **Moyle, D.D., Bowden, R.W. Fracture of Human Femoral Bone. *J Biomech*, 17(3), 203-13 (1984).**

589. Mucciardi, A.N., Sanders, J.D., Eppinger, R.H. Prediction of Brain Injury Measures from Head Motion Parameters. Proceedings of the 21st Stapp Car Crash Conference, New Orleans, LA, October 19-21, 1977, (Society of Automotive Engineers Proceedings No. P-73). Warrendale, PA, Society of Automotive Engineers, 369-415 (1977).
590. Mulligan, G.W., Pizey, G.S., Lane, D., Andersson, L., English, C., Kohut, C. An Introduction to the Understanding of Blunt Chest Trauma. IN: the Human Thorax: Anatomy, Injury and Biomechanics. (A Continuing Education Course Developed by SAE Automobile Body Activity—Passenger Protection Committee). Warrendale, PA, Society of Automotive Engineers, 11-36 (1976).
591. Mustajoki, P., Nummi, J., Meurman, K. Permanent Changes in the Spines of Military Parachutists. Aviat Space Environ Med, 49(6), 823-826 (1978 Jun).
592. Myers, B.S., McElhaney, J.H., Doherty, B.J., Paver, J.G., Nightingale, R.W., Ladd, T.P., Gray, L. Responses of the Human Cervical Spine to Torsion. Proceedings of the 33rd Stapp Car Crash Conference, Washington, D.C., October 4-6, 1989, (Society of Automotive Engineers Proceedings No. P-227). Warrendale, PA, Society of Automotive Engineers, 215-22 (1989).
593. Myklebust, J., Sances Jr., A., Maiman, D., Pintar, F., Chilbert, M., Rauschnig, W., Larson, S., Cusick, J., Ewing, C., Thomas, D., Saltzberg, B. Experimental Spinal Trauma Studies in the Human and Monkey Cadaver. Proceedings of the 27th Stapp Car Crash Conference, San Diego, CA, October 17-19, 1983, (Society of Automotive Engineers Proceedings No. P-134). Warrendale, PA, Society of Automotive Engineers, 149-61 (1983).
594. Nagel, D.A., Burton, D.S., Manning, J. The Dashboard Knee Injury. Clin Orthop, (126), 203-8 (1977 Jul-Aug).
595. Nagel, D.A., States, J.D. Dashboard and Bumper Knee—Will Arthritis Develop? Proceedings of the 21st Annual Conference of the American Association for Automotive Medicine, Vancouver, British Columbia, Canada, September 15-17, 1977. Morton Grove, IL, American Association for Automotive Medicine, 1-7 (1977).
596. Nahum, A.M. Chest Trauma. IN: Biomechanics and Its Application to Automotive Design, a Continuing Education Course Developed by SAE (P-49). New York, NY, Society of Automotive Engineers, 1-7 (1973).
597. Nahum, A.M., Gatts, J.D., Gadd, C.W., Danforth, J. Impact Tolerance of the Skull and Face. Proceedings of the 12th Stapp Car Crash Conference, Detroit, MI, October 22-23, 1968, (Society of Automotive Engineers Proceedings No. P-26). New York, NY, Society of Automotive Engineers, 302-16 (1968).

598. Nahum, A.M., Smith, R.W. **An Experimental Model for Closed-head Impact Injury. Proceedings of the 20th Stapp Car Crash Conference, Dearborn, MI, October 18-20, 1976, (Society of Automotive Engineers Proceedings No. P-66). Warrendale, PA, Society of Automotive Engineers, 785-814 (1976).**
599. Nahum, A.M., Melvin, J., eds. **The Biomechanics of Trauma. Norwalk, CT: Appleton-Century-Crofts, Publishers, (1985).**
600. Nahum, A.M., Smith, R., Ward, C.C. **Intracranial Pressure Dynamics During Head Impact. Proceedings of the 21st Stapp Car Crash Conference, New Orleans, LA, October 19-21, 1977, (Society of Automotive Engineers Proceedings No. P-73). Warrendale, PA, Society of Automotive Engineers, 339-66 (1977).**
601. Nahum, A.M., Ward, C.C., Schneider, D., Raasch, F., Adams, S. **A Study of Impacts to the Lateral Protected and Unprotected Head. Proceedings of the 25th Stapp Car Crash Conference, San Francisco, CA, September 28-30, 1981, (Society of Automotive Engineers Proceedings No. P-97). Warrendale, PA, Society of Automotive Engineers, 241-68 (1981).**
602. Nanda, S.P. **Brain Injury Due to an Input Angular Acceleration of the Head. An Analytical Study. Math Computer Modelling, 13(1), 1-6 (1990).**
603. **National Accident Sampling System (NASS) Analytical User's Manual. 1985 File. Washington, D.C., U.S. Department of Transportation, National Highway Traffic Safety Administration, 1985.**
604. **The Naval Aircraft Crash Environment: Aircrew Survivability and Aircraft Structural Response. NADC-88106-60, September 9, 1988.**
605. Neathery, R.F., Kroell, C.K., Mertz, H.J. **Prediction of Thoracic Injury from Dummy Responses. Proceedings of the 19th Stapp Car Crash Conference, San Diego, CA, November 17-19, 1975 (Society of Automotive Engineers Proceedings No. P-62). Warrendale, PA, Society of Automotive Engineers, 295-316 (1975).**
606. Neathery, R.F., Mertz, H.J., Hubbard, R.P., Henderson, M.R. **The Highway Safety Research Institute Dummy Compared with General Motors Biofidelity Recommendations and the Hybrid II Dummy. Proceedings of the 3rd International Conference On Occupant Protection, Troy, MI, July 10-12, 1974, (Society of Automotive Engineers Proceedings No. P-53). Warrendale, PA, Society of Automotive Engineers, 357-383 (1974).**
607. **Neck Injury in Advanced Military Aircraft Environments. Neuilly-sur-Seine, France, Advisory Group for Aerospace Research and Development (AGARD-CP-471), [In English and French], February 1990.**

608. Neifeld, G.L., Keene, J.G., Hevesy, G., Leikin, J., Proust, A., Thisted, R.A. Cervical Injury in Head Trauma. *J Emerg Med*, 6(3), 203-207 (1988 May-Jun).
609. Nelson, C.L. Detection of Soft Tissue Injuries of the Cervical Spine. Proceedings of the 14th Annual Conference of the American Association for Automotive Medicine, Ann Arbor, MI, November 19-20, 1970. Morton Grove, IL, American Association for Automotive Medicine, 1970.
610. Nelson, W.D. Restraint System Effectiveness. Proceedings of the 15th Annual Conference of the American Association for Automotive Medicine, Colorado Springs, CO, October 20-23, 1971. Morton Grove, IL, American Association for Automotive Medicine, 1972.
611. Nestle, A.J. Aerodynamic Forces Experienced During Ejection. AFAMRL-TR-80-20, March 1981.
612. Nestle, A.J. Torso Experienced Aerodynamic Forces Experienced During Ejection. AFAMRL-TR-80-20, February 1981.
613. Newhouse, H.L., Payne, P.R., Brown, J.P. Wind Tunnel Measurements of Total Force and Extremity Flail Potential Forces On a Crewmember in Close Proximity to a Cockpit. AMRL-TR-79-110, December 1980.
614. Newman, J.A. Head Injury Criteria in Automotive Crash Testing. Proceedings of the 24th Stapp Car Crash Conference, Troy, MI, October 15-17, 1980, (Society of Automotive Engineers Proceedings No. P-88). Warrendale, PA, Society of Automotive Engineers, 703-47 (1980).
615. Newman, J.A. The Influence of Time Duration as a Failure Criterion in Helmet Evaluation. Presented at the International Off-Highway Meeting & Exposition, Milwaukee, WI, September 13-16, 1982, (Society of Automotive Engineers Technical Paper No. 821088). Warrendale, PA, Society of Automotive Engineers, 1-7 (1982).
616. Newman, J.A. On the Use of the Head Injury Criterion (HIC) in Protective Headgear Evaluation. Proceedings of the 19th Stapp Car Crash Conference, San Diego, CA, November 17-19, 1975, (Society of Automotive Engineers Proceedings No. P-62). Warrendale, PA, Society of Automotive Engineers, 615-640 (1975).
617. Newman, J.A. Temporal Characteristics of Translational Acceleration in the Prediction of Helmeted Head Injury. IN: Impact Injury Caused by Linear Acceleration: Mechanisms, Prevention and Cost (AGARD-CP-322-82). Neuilly-sur-Seine, France, Advisory Group for Aerospace Research and Development. AGARD-CP-322, A1-A7 (1982).

618. Nichols, C.G., Young, D.H., Schiller, W.R. Evaluation of Cervicothoracic Junction Injury. *Ann Emerg Med*, 16(6), 640-642 (1987 Jun).
619. Niederer, P.F., Schlumpf, M.R. Influence of Vehicle Front Geometry On Impacted Pedestrian Kinematics. Proceedings of the 28th Stapp Car Crash Conference, Chicago, IL, November 6-7, 1984, (Society of Automotive Engineers Proceedings No. P-152). Warrendale, PA, Society of Automotive Engineers, 135-47 (1984).
620. Niefeld, G.L., Keene, J.G., Hevesy, G., Leikin, J., Proust, A., Thisted, R.A. Cervical Injury in Head Trauma. *J Emerg Med*, 6(3), 203-207 (1988 May-Jun).
621. Nigg, B.M. Biomechanics, Load Analysis and Sports Injuries in the Lower Extremities. *Sports Med*, 2(5), 367-79 (1985 Sep-Oct).
622. Nightingale, R.W., Doherty, B.J., Myers, B.S., McElhaney, J.H., Richardson, W.J. The Influence of End Condition On Human Cervical Spine Injury Mechanisms. Proceedings of the 35th Stapp Car Crash Conference, San Diego, CA, November 18-20, 1991 (Society of Automotive Engineers Proceedings No. P-251). Warrendale, PA, Society of Automotive Engineers, 391-9 (1991).
623. Nilsson, S., Planath, I. Facial Injury Occurrence in Traffic Accidents and Its Detection by a Load Sensing Face. Proceedings of the 11th International Technical Conference On Experimental Safety Vehicles, Washington, D.C., May 12-15, 1987. Washington, D.C., U.S. Department of Transportation, National Highway Traffic Safety Administration, 613-20 (1987).
624. Noble, R.E. Helmets and Head Protection in CF Ejections 1967-1973. *Aviat Space Environ Med*, 46(10), 1265-6 (1975 Oct).
625. Noble, R.E., Olsen, S.W. Accident Statistics Relevant to Windblast. IN: Biodynamic Response to Windblast. Neuilly-sur-Seine, France, Advisory Group for Aerospace Research and Development (AGARD-CP-170), B4-1-B4-4, (1975).
626. Noguchi, T.T., Rehman, I., Hieshima, G., Grinnell, V.S., Itabashi, H.H. Neck Injury Assessment Protocol. Final Report Oct 76-Mar 78. Washington, D.C., U.S. Department of Transportation, National Highway Traffic Safety Administration, March 1978.
627. Nolte, L.P., Panjabi, M.M. Contribution to the Stability Analysis of Intact and Injured Lumbosacral Spine. *J Biomech*, 22(10), [ABSTRACT ONLY], 1064 (1989 Oct).
628. Norton, M.J., Stanford, G.G., Weigelt, J.A. Early Detection of Myocardial Contusion and Its Complications in Patients with Blunt Trauma. *Am J Surg*, 160(6), 577-81 (1990 Dec).

629. Nusholtz, G.S., Bender, M., Kaiker, P.S. Use of High-speed Cineradiography in Head-impact Experiments. *Exp Techniques* 1987 Feb, 11(2), 18-21.
630. Nusholtz, G.S., Kaiker, P.S. Kinematics of the Human Cadaver Cervical Spine in Response to Superior-Inferior Loading of the Head. Final Technical Report. Ann Arbor, MI, University of Michigan, Transportation Research Institute, UMTRI-86-31, July 1986.
631. Nusholtz, G.S., Kaiker, P.S., Gould, W.S. Two Factors Critical in the Pressure Response of the Impacted Head. *Aviat Space Environ Med*, 58(12), 1157-1164 (1987 Dec).
632. Nusholtz, G.S., Kaiker, P.S., Muscott, G.J., Suggitt, B.R. UMTRI Experimental Techniques in Head Injury Research. Presented at the Government Industry Meeting and Exposition, Washington, D.C., May 20-23, 1985. (Society of Automotive Engineers Technical Paper No. 851244). Warrendale, PA, Society of Automotive Engineers, 1-10 (1985).
633. Nusholtz, G.S., Melvin, J.W., Huelke, D.F., Alem, N.M. Alem, and Blank, J.G. Response of the Cervical Spine to Superior-Inferior Head Impact. Proceedings of the 25th Stapp Car Crash Conference, San Francisco, CA, September 28-30, 1981, (Society of Automotive Engineers Proceedings No. P-97). Warrendale, PA, Society of Automotive Engineers, 197-237 (1981).
634. Nyquist, G.W. Injury Tolerance Characteristics of the Adult Human Lower Extremities Under Static and Dynamic Loading. IN: *Biomechanics and Medical Aspects of Lower Limb Injuries*, San Diego, CA, October 29-30, 1986, (Society of Automotive Engineers Proceedings No. P-186). Warrendale, PA, Society of Automotive Engineers, 79-90 (1986).
635. Nyquist, G.W., Begman, P.C., King, A.I., Mertz, H.J. Correlation of Field Injuries and GM Hybrid III Dummy Responses for Lap-Shoulder Belt Restraint. *J Biomech Eng*, 102, 103-9 (May 1980).
636. Nyquist, G.W., Cavanaugh, J.M., Goldberg, S.J., King, A.I. Facial Impact Tolerance and Response. Proceedings of the 30th Stapp Car Crash Conference, San Diego, CA, October 27-29, 1986, (Society of Automotive Engineers Proceedings No. P-189). Warrendale, PA, Society of Automotive Engineers, 379-400 (1986).
637. Nyquist, G.W., Denton, R.A. Crash Test Dummy Lower Leg Instrumentation for Axial Force and Bending Moment. *ISA Trans*, 18(3), 13-22 (1979).

638. Nyquist, G.W., DuPont, F.T., Patrick, L.M. Pick-up Truck Rear Window Tempered Glass as a Head Restraint: Head and Neck Loads Relative to Injury Reference Criteria. Proceedings of the 28th Stapp Car Crash Conference, Chicago, IL, November 6-7, 1984, (Society of Automotive Engineers Proceedings No. P-152). Warrendale, PA, Society of Automotive Engineers, 75-86 (1984).
639. Nyquist, G.W., Savage, C.M., Fletcher, D.L. Dynamics and Biomechanics of Motorcycle-to-car Glancing Impact: Theory and Experiment. Proceedings of the 29th Annual Conference of the American Association for Automotive Medicine, Washington, D.C., October 7-9, 1985. Arlington Heights, IL, American Association for Automotive Medicine, 255-73 (1985).
640. O'Malley, K.F., Ross, S.E. The Incidence of Injury to the Cervical Spine in Patients with Craniocerebral Injury. *J Trauma*, 28(10), 1476-8 (1988 Oct).
641. Obergefell, L.A., Avula, X.J.R., Kaleps, I. Calculation of Stopping Torques for Limbs Subjected to Aerodynamic Loads. Presented at the Winter Annual Meeting of the American Society of Mechanical Engineers On Computation Methods in Bioengineering, Chicago, IL, November 27-December 2, 1988. New York, NY, American Society of Mechanical Engineers, 169-176 (1988).
642. Occupant Injury Tolerance Factors. Presented at the Williamsburg Conference On Highway Safety Research. (Society of Automotive Engineers SP-377). New York, NY, Society of Automotive Engineers, Vehicle Research Institute, 1973.
643. Ommaya, A.K., Faas, F., Yarnell, P. Whiplash Injury and Brain Damage: An Experimental Study. *JAMA*, 204(4), 285-9 (1968 Apr 22).
644. Ommaya, A.K., Fisch, F.J., Mahone, R.M., Corrao, P., Letcher, F. Comparative Tolerances for Cerebral Concussion by Head Impact and Whiplash Injury in Primates. Proceedings of the International Automobile Safety Conference, Detroit, MI, May 13-15, 1970, (Society of Automotive Engineers Proceedings No. P-30). New York, NY, Society of Automotive Engineers, 808-17 (1970).
645. Ommaya, A.K., Hirsch, A.E. Protection of the Brain from Injury During Impact: Experimental Studies in the Biomechanics of Head Injury. IN: Linear Acceleration of Impact Type, Neuilly-sur-Seine, France, Advisory Group for Aerospace Research and Development. AGARD-CP-88-71, 7-i-7-19, (1971).
646. Ommaya, A.K., Hirsch, A.E. Tolerances for Cerebral Concussion from Head Impact and Whiplash in Primates. *J Biomech*, 4(1), 13-21 (1971 Jan).

647. **Ommaya, A.K., Thibault, L.E. Head and Spinal Injury Tolerance with No Direct Head Impact. Proceedings of the 1973 International Conference On the Biokinetics of Impact (IRCOBI), Bron, France, 311-319 (1973).**
648. **Ommaya, A.K., Yarnell, P. Subdural Haematoma After Whiplash Injury. Lancet, 2(614), 237-9 (1969 Aug 2).**
649. **Ono, K., Kikuchi, A., Nakamura, M., Kobayashi, H., Nakamura, N. Human Head Tolerance to Sagittal Impact Reliable Estimation Deduced from Experimental Head Injury Using Subhuman Primates and Human Cadaver Skulls. Proceedings of the 24th Stapp Car Crash Conference, Troy, MI, October 15-17, 1980, (Society of Automotive Engineers Proceedings No. P-88). Warrendale, PA, Society of Automotive Engineers, 103-60 (1980).**
650. **Orne, D. A Mathematical Model of Spinal Response to Impact [Ph.D. Thesis]. Ann Arbor, MI, Michigan University, 1969.**
651. **Orne, D., Liu, Y.K. A Mathematical Model of Spinal Response to Impact. J Biomech, 4(1), 49-71 (1971 Jan).**
652. **Ouellet, J.V., Hurt, H.H. Jr., Thom, D.R. Collision Performance of Contemporary Crashbars and Motorcycle Rider Leg Injuries. IN: Accident Reconstruction Technologies: Pedestrians & Motorcycles in Automotive Collisions, (Society of Automotive Engineers Proceedings No. P-193). Warrendale, PA, Society of Automotive Engineers, 497-511 (1989).**
653. **Outwater, J.O., Jacobs, C.H., Castle, R.W. The Ultimate Strength and Failure Mechanism of Anthropoid Knee Joints. AMRL-TR-71-29 Paper No. 15, December 1971.**
654. **Overgaard, S., Solgaard, S. Osteoarthritis After Colles' Fracture. Orthopedics, 12(3), 413-6 (1989 Mar).**
655. **Palmer, R.W. SPH-4 Aircrew Helmet Impact Protection Improvements 1970-1990. USAARL-91-11, February 1991.**
656. **Panjabi, M.M., Summers, D.J., Pelker, R.R., Videman, T., Friedlaender, G.E., Southwick, W.O. Three-dimensional Load-displacement Curves Due to Forces On the Cervical Spine. J Orthop Res, 4(2), 152-61 (1986).**
657. **Panjabi, M.M., White, A.A. 3d, Keller, D., Southwick, W.O., Friedlaender, G. Stability of the Cervical Spine Under Tension. J Biomech, 11(4), 189-97 (1978).**

- 658. **Parker, P.G. Fractures of the Pelvis. Proc Mine Med Off Assoc, 52(415), 58-60 (1973 Jan-Apr).**
- 659. **Parrini, L., Cabitza, P., Verdoia, C., Garbagna, P. Vertebral Fractures. Classification, Pathological and Radiographic Anatomy, Radiographic Diagnosis. Ital J Orthop Traumatol, 9 Suppl, 5-20 (1983 Nov).**
- 660. **Patrick, L.M. Frontal Force Impact Tolerance of the Human Thorax. IN: the Human Thorax: Anatomy, Injury, and Biomechanics (A Continuing Education Course Developed by SAE Automobile Body Activity-Passenger Protection Committee). Warrendale, PA, Society of Automotive Engineers, 37-48 (1976).**
- 661. **Patrick, L.M. Potential Head and Neck Injury from Windshield Impacts. Conference On Road Safety, Vol. 2, Brussels, Belgium, A10.1-A10.24, (1968).**
- 662. **Patrick, L.M. Trauma as a Function of Forces and Accelerations in Collisions. Final Report. Detroit, MI, Motor Vehicle Manufacturers Association. MVMA-WSU-74-04, March 15, 1974.**
- 663. **Patrick, L.M., Levine, R.S. Injury to Unembalmed Belted Cadavers in Simulated Collisions. Proceedings of the 19th Stapp Car Crash Conference, San Diego, CA, November 17-19, 1975, (Society of Automotive Engineers Proceedings No. P-62). Warrendale, PA, Society of Automotive Engineers, 79-115 (1975).**
- 664. **Paver, J.G., McElhaney, J.H. Selected Bibliography On Head and Neck Injury and Protection. Biodynamics Data Bank, Wright-Patterson AFB, OH.**
- 665. **Payne, C.F., Bosee, R. The Mechanism and Cause of Crash Landing and Ejection Vertebral Injuries in U.S. Naval Aviation. NAEC-ACEL-467, 8 July 1963.**
- 666. **Payne, P.R. The Heat Pulse Associated with Escape from an Aircraft at Supersonic Speed. Wright-Patterson AFB, OH, Aerospace Medicine Research Laboratories. AMRL-TR-76-2, June 1976.**
- 667. **Payne, P.R. Injury Potential of Ejection Seat Cushions. J Aircraft, 6(3), 273-8 (1969 May-Jun).**
- 668. **Payne, P.R. A New Look at Parachute Opening Dynamics. Aeronautical J, 85-93 (1973 Feb).**
- 669. **Payne, P.R. Notes On the Initiation of Limb Flailing. AMRL-TR-71-045, August 1971.**

670. **Payne, P.R. On Pushing Back the Frontiers of Flail Injury. IN: Biodynamic Response to Windblast, Neuilly-sur-Seine, France, Advisory Group for Aerospace Research and Development. AGARD-CP-170, B9-1-B9-7 (1975).**
671. **Payne, P.R. On the Avoidance of Limb Flail Injury by Ejection Seat Stabilization. AMRL-TR-74-9, May 1974.**
672. **Payne, P.R. Some Aspects of Biodynamic Modeling for Aircraft Escape Systems. AMRL-TR-71-29, 233-236 (December 1971).**
673. **Payne, P.R. Some Studies Relating to "Limb Flailing" After an Emergency Escape from an Aircraft. AMRL-TR-73-24, December 1974.**
674. **Payne, P.R. Spinal Injury in the Crash Environment. IN: Aircraft Crashworthiness (Proceedings of a Symposium, Cincinnati, OH, October 6-8, 1975). Saczalski, Kenneth, Singley, George T. 3d, Pilkey, Walter D. And Huston, Ronald L., eds. Charlottesville, VA, University Press of Virginia, 273-298 (1975).**
675. **Payne, P.R., Hawker, F.W., Euler, A.J. Stability and Limb Dislodgement Force Measurements with the F-105 and ACES-II Ejection Seats. AMRL-TR-75-8, July 1975.**
676. **Payne, P.R., Hawker, F.W. USAF Experience of Flail Injury for Noncombat Ejections in the Period 1964-1970. AMRL-TR-72-111, May 1974.**
677. **Pearson, R.G. Relationship Between Impact Variables and Injuries Sustained in Lightplane Accidents. AV-CIR-61-5, 61-95 (August 1961).**
678. **Pereira, M., Ashton, S.J. Experimental Development of Pedestrian Head Injury Tolerance Data. IN: Pedestrian Impact Injury and Assessment, (Society of Automotive Engineers Proceedings No. P-121). Warrendale, PA, Society of Automotive Engineers, 77-85 (1983).**
679. **Perey, O. Biomechanical Problems of the Lumbar Spine—Human Tolerance, Impact, Acceleration Stress, Spinal Fracture. Presented at a Symposium On Impact Acceleration Stress Sponsored by the National Academy of Sciences, Brooks AFB, TX, November 27-29, 1961, 25-26 (1961).**
680. **Perey, O. Fracture of the Vertebral End Plate in the Lumbar Spine: An Experimental Biomechanical Investigation. Acta Orthopaed Scand Suppl. 25, 1-101 (1957).**

681. **Perl, T.R., Nilsson, S., Planath, I., Wille, M.G. Deformable Load Sensing Hybrid III Face. Proceedings of the 33rd Stapp Car Crash Conference, Washington, D.C., October 4-6, 1989, (Society of Automotive Engineers Proceedings No. P-227). Warrendale, PA, Society of Automotive Engineers, 29-42 (1989).**
682. **Perrone, N. A Mathematical Model to Predict Skull Fracture Under Impact Loads. IN: Mathematical Modeling Biodynamic Response to Impact, (Society of Automotive Engineers Proceedings No. SP-412). Warrendale, PA, Society of Automotive Engineers, 1-8 (1976).**
683. **Perry, D.R., Dyer, L.C. Incidence, Nature and Extent of Injury in Crash Landings and Bailouts. Report No. 1, November 1956.**
684. **Perryman, J.S. Knee Injuries in Skiing. Presented at the Winter Annual Meeting of the American Society of Mechanical Engineers On Biomechanics in Sport—a 1987 Update, Boston, MA, December 13- 18, 1987. New York, NY, American Society of Mechanical Engineers, 33-34 (1987).**
685. **Pesman, G.J., Eiband, A.M. Crash Injury. TN-3775, November 1956.**
686. **Peterson, J.J., Smith, D.E. A General Statistical Approach for Using Auxiliary Information in the Development of an Impact Acceleration Injury Prediction Model. TRI-112-6, August 1980.**
687. **Piergallini, J.R., Stoll, A.M. Technique and Measurement of Heat Flux and Flame Temperature in Rocket Plume Exposures. NADC-80093-60, May 1980.**
688. **Pintar, F.A., Sances, A. Jr., Yoganandan, N., Reinartz, J., Maiman, D.J., Suh, J.K. Biodynamics of the Total Human Cadaveric Cervical Spine. Proceedings of the 34th Stapp Car Crash Conference, Orlando, FL, November 4-7, 1990, (Society of Automotive Engineers Proceedings No. P-236). Warrendale, PA, Society of Automotive Engineers, 55-72 (1990).**
689. **Pintar, F.A., Yoganandan, N., Sances, A. Jr., Reinartz, J., Harris, G., Larson, S.J. Kinematic and Anatomical Analysis of the Human Cervical Spinal Column Under Axial Loading. Proceedings of the 33rd Stapp Car Crash Conference, Washington, D.C., October 4-6, 1989, (Society of Automotive Engineers Proceedings No. P-227). Warrendale, PA, Society of Automotive Engineers, 191-214 (1989).**
690. **Pirson, J., Verbiest, E. A Study of Some Factors Influencing Military Parachute Landing Injuries. Aviat Space Environ Med, 56(6), 564-7 (1985 Jun).**

691. Piziali, R.L. Cervical Spine Injuries in Sports. Presented at the Annual Winter Meeting of the American Society of Mechanical Engineers, Boston, MA, December 13-18, 1987. New York, NY, American Society of Mechanical Engineers, 123-7 (1987).
692. Planath, I., Nilsson, S., Cesari, D. Facial Fracture Protection Criteria for the Hybrid III Load Sensing Face. *Accid Anal Prev*, 23(1), 95-103 (1991 Feb).
693. **Planath, I., Nilsson, S. Testing and Evaluation of a Hybrid III Load Sensing Face. *Accid Anal Prev*, 21(5), 483-92 (1989 Oct).**
694. Plank, G.R. Review of Chest Deflection Measurement Techniques and Transducers. Final Report, September, 1976-May 1977. Washington, D.C., U.S. Department of Transportation, National Highway Traffic Safety Administration. DOT-TSC-NHTSA-78-33, (1978).
695. Plank, G.R., Gould, H.H., Eppinger, R.H. On the Relationship Between Kinematic Variables and Structural Failure in a Viscoelastic Medium Under Impact. Proceedings of the 11th International Technical Conference On Experimental Safety Vehicles, Washington, D.C., May 12-15, 1987. Washington, D.C., U.S. Department of Transportation, National Highway Traffic Safety Administration, 284-8 (1987).
696. Plank, G.R., Ofsevit, D., Warner, A. Occupant Motion Sensors: Development and Testing of a Piezoresistive Mouthpiece Rotational Accelerometer. Interim Report. Washington, D.C., U.S. Department of Transportation, National Highway Traffic Safety Administration, DOT-TSC-NHTSA-73-5, (July 1973).
697. Plank, G.R., Weinstock, H., Coltman, M., Lee, H. Methodology for the Calibration of and Data Acquisition with a Six-Degree-of-Freedom Acceleration Measurement Device. Final Report July 1983-February 1988. Washington, D.C., U.S. Department of Transportation, National Highway Traffic Safety Administration, DOT-TSC-NHTSA-88-3, (June 1989).
698. **Plesha, M., Belytschko, T. Analysis of Vertebral Stress Distributions and Ejection-related Injury Mechanisms. AFAMRL-TR-80-67, February 1981.**
699. Pope, M.E., Kroell, C.K., Viano, D.C., Warner, C.Y., Allen, S.D. Postural Influences On Thoracic Impact. Proceedings of the 23rd Stapp Car Crash Conference, San Diego, CA, October 17-19, 1979, (Society of Automotive Engineers Proceedings No. P-82). Warrendale, PA, Society of Automotive Engineers, 765-95 (1979).
700. Povlishock, J.T., Kontos, H.A., Ellis, E.F. Current Thoughts on Experimental Head Injury. IN: Textbook of Head Injury, Becker, D.F. and Gudeman, S.K., eds. Philadelphia: W.B. Saunders, 451-8 (1989).

701. Powell, W.R., Advani, S.H., Clark, R.N., Ojala, S.J., Holt, D.J. Investigation of Femur Response to Longitudinal Impact. Proceedings of the 18th Stapp Car Crash Conference, Ann Arbor, MI, December 4-5, 1974. (Society of Automotive Engineers Proceedings No. P-56), Warrendale, PA, Society of Automotive Engineers, 539-56 (1974).
702. Powell, W.R., Ojala, S.J., Advani, S.H., Martin, R.B. Cadaver Femur Responses to Longitudinal Impacts. Proceedings of the 19th Stapp Car Crash Conference, San Diego, CA, November 17-19, 1975, (Society of Automotive Engineers Proceedings No. P-62). Warrendale, PA, Society of Automotive Engineers, 561-79 (1975).
703. Prasad, P., King, A.I. The Dynamic Response of the Spine During +Gz Acceleration. Annual Report March 15, 1972-July 31, 1973, Arlington, VA, Department of the Navy, Office of Naval Research. N00014-69-A-0235-0001, November 1973.
704. Prasad, P., King, A.I., Ewing, C.L. The Role of Articular Facets During +Gz Acceleration. J Applied Mech, Trans ASME 321-6 (1974 Jun).
705. Prasad, P., Mertz, H.J. The Position of the United States Delegation to the ISO Working Group 6 On the Use of HIC in the Automotive Environment. Presented at the Government/Industry Meeting & Exposition, Washington, D.C., May 20-23, 1985, (Society of Automotive Engineers Technical Paper No. 851246). Warrendale, PA, Society of Automotive Engineers. 1-11 (1985).
706. Prasad, P., Mital, N., King, A.I., Patrick, L.M. Dynamic Response of the Spine During +Gx Acceleration. Proceedings of the 19th Stapp Car Crash Conference, San Diego, CA, November 17-19, 1975, (Society of Automotive Engineers Proceedings No. P-62). Warrendale, PA, Society of Automotive Engineers, 869-97 (1975).
707. Privitzer, E. Model Evaluation of Spinal Injury Likelihood for Various Ejection System Parameter Variations. Shock Vibra Bull, 55 (Part 3), 99-115 (1985 Jun).
708. Privitzer, E., Hosey, R.R., Ryerson, J.E. Validation of a Biodynamic Injury Prediction Model of the Head-spine System. IN: Impact Injury Caused by Linear Acceleration. Neuilly-sur-Seine, France, Advisory Group for Aerospace Research and Development (AGARD-CP-322), 30.1-30.10 (October 1982).
709. Privitzer, E., Settecerri, J.J. Dynamic Analysis of Inertial Loading Effects of Head Mounted Systems. SAFE J, 17, 16-22 (1987 Summer).
710. Purvis, G.D. Displaced, Unstable Ankle Fractures: Classification, Incidence, and Management of a Consecutive Series. Clin Orthop, (165), 91-8 (1982 May).

711. Raddin, J.H., Jr., Hearon, B.F. Dynamic Preload as an Impact Protection Concept. Proceedings of the SAFE Silver Anniversary Symposium, Las Vegas, NV, December 1981.
712. Raddin, J.H., Jr., Specker, L.J., Brinkley, J.W. Minimizing the Sequenced Delay Time for Escape from High-Speed, Low-Level Flight Profiles. IN: High-Speed, Low-Level Flight: Aircrew Factors, Neuilly-sur-Seine, France, Advisory Group for Aerospace Research and Development. AGARD-CP-267.
713. Radiological Study of Fractures of C1 and C2. IN: Physiopathology and Pathology of Spinal Injuries in Aerospace Medicine. Neuilly-sur-Seine, France, Advisory Group for Aerospace Research and Development. AGARD-AG-250(ENG)-2ND, 199-210 (February 1982).
714. Rai, K., Gurusidappa, G. Spinal Injury Pattern Due to Ejections. Aviat Med, 23, 41-47 (1979 Jun).
715. Ramet, M., Cesari, D. Etat de la Question sur les Tolerances du Segment Thoracique [State-of-the-Art on Thoracic Tolerances.] Proceedings of the 1973 International Conference on the Biokinetics of Impacts, Bron. France, IRCOBI, 367-86 (1973).
716. Rangarajan, N. Development of a Microcomputer-Based Software System for Use in Crewmember Ejection Analysis. AAMRL-SR-89-501, August 1989.
717. Rasmussen, R.R. Jr., Kaleps, I., Armstrong, H.G. Development of an Advanced Dynamic Anthropomorphic Manikin---ADAM for Military Applications. Proceedings of the 11th International Technical Conference On Experimental Safety Vehicles, Washington, D.C., May 12-15, 1987. Washington, D.C., U.S. Department of Transportation, National Highway Traffic Safety Administration, 332-5 (1987).
718. Rasmussen, R.R., Kaleps, I. The USAF Advanced Dynamic Anthropomorphic Manikin (ADAM). IN: Implications of Advanced Technologies for Air and Spacecraft Escape. Neuilly-sur-Seine, France, Advisory Group for Aerospace Research and Development AGARD-CP-472, 9-1-9-7 (February 1990).
719. Rastogi, S., Wild, B.R., Duthie, R.B. Biomechanical Aspects of Femoral Fractures in Automobile Accidents. J Bone Joint Surg [Br], 68(5), 760-6 (1986 Nov).
720. Rattenbury, S.J., Gloyns, P.J., Hayes, H.R., Griffiths, D.K. The Biomechanical Limits of Seat Belt Protection. Proceedings of the 23rd Annual Conference of the American Association for Automotive Medicine, Louisville, KY, October 4-6, 1979. Morton Grove, IL, American Association for Automotive Medicine, (1979).

721. Reddi, M.M., Tsai, H.C. Computer Simulation of Human Thoracic Skeletal Response. Abstract Summary Report. Final Report 26 Jun 75-31 Jan 77. Washington, D.C., U.S. Department of Transportation, National Highway Traffic Safety Administration. DOT-HS-803-208, February 1977.
722. Reddi, M.M., Tsai, H.C., Wendt, F.W., Rogers, V.A., Erb, R.A. Thoracic Impact Injury Mechanism. Volume I. Final Report June 1972-December 1974. Washington, D.C., U.S. Department of Transportation, National Highway Traffic Safety Administration. DOT-HS-801-710, August 1975.
723. Reddi, M.M., Tsai, H.C., Wendt, F.W., Rogers, V.A., Erb, R.A. Thoracic Impact Injury Mechanism. Volume II. Final Report July 1972-December 1974. Washington, D.C., U.S. Department of Transportation, National Highway Traffic Safety Administration. DOT-HS-801-710, August 1975.
724. Reidelbach, W., Zeidler, F. What Is a Realistic Lateral Impact Test? Presented at the International Congress & Exposition, Detroit, MI, February 28-March 4, 1983, (Society of Automotive Engineers Technical Paper No. 830460). Warrendale, PA, Society of Automotive Engineers, 1-4 (1983).
725. Reigstad, A. Traumatic Dislocation of the Hip. *J Trauma*, 20(7), 603-6 (1980 Jul).
726. **A Review of Neck Injury and Impaired Consciousness Associated with US Navy Ejections January 1, 1969-December 31, 1979. IN: Report On the Working Group On the Clinical and Biomedical Evaluation of Trauma and Fatalities Associated with Aircrew Ejection and Crash. Neuilly-sur-Seine, France, Advisory Group On Aerospace Research and Development. AGARD-AR-194, 11-16 (December 1984).**
727. Rice, E.V., Brady, J.A., Van Dyke, R.S. The Role of Personal Restraints in Navy Ejector Mishaps. Proceedings of the 13th Annual Conference and Trade Exhibit of the Survival and Flight Equipment Association, San Antonio, TX, September 21-26, 1975. Canoga Park, CA, SAFE Association, 58-61 (1987).
728. Rice, E.V., Luehrs, R.E. An Analysis of Fatality Causal Factors Associated with Unsuccessful Ejections in the U.S. Navy. Proceedings of the 7th Annual Symposium of the Survival and Flight Equipment Association, Las Vegas, NV, October 27-30, 1969. Canoga Park, CA, SAFE Association, 302-309 (1969).
729. Rice, E.V., Ninow, E.H. The Man-machine Interface—a Study of Injuries Incurred During Ejection from U.S. Navy Aircraft. Preprint of Paper Presented at the 43rd Annual Scientific Meeting of the Aerospace Medical Association, Bal Harbour, FL, May 8-11, 1972. Washington, D.C., Aerospace Medical Association, 51-52 (1972).

730. Richards, R.R., Waddell, J.P., Sullivan, T.R., Ashworth, M.A., Rorabeck, C.H. **Infra-isthmal Fractures of the Femur: a Review of 82 Cases.** J Trauma, 24(8), 735-41 (1984 Aug).
731. Ridella, S.A., Viano, D.C. **Determining Tolerance to Compression and Viscous Injury in Frontal and Lateral Impacts.** Proceedings of the 34th Stapp Car Crash Conference, Orlando, FL, November 4-7, 1990, (Society of Automotive Engineers Proceedings No. P-236). Warrendale, PA, Society of Automotive Engineers, 349-56 (1990).
732. **Ring, W.S., Brinkley, J.W., Noyes, F.R. USAF Non-combat Ejection Experience 1968-1973 Incidence, Distribution, Significance and Mechanism of Flail Injury. IN: Biodynamic Response to Windblast.** Neuilly-sur-Seine, France, Advisory Group On Aerospace Research and Development. AGARD-CP-170, B1-1-B1-8 (July 1975).
733. Road Vehicles. **Technique of Measurement in Impact Tests. Instrumentation.** International Standards Organization. ISO Standard #6487.
734. **Roaf, R. Study of Mechanics of Spinal Injury.** J Bone Joint Surg [Br], 42(4), 810 (Nov 1960).
735. Robbins, D.H. **Impact Head Injury Data Base. Final Report.** Ann Arbor, MI, University of Michigan, Highway Safety Research Institute. UM-HSRI-80-21, (1980 February).
736. Robbins, D.H. **Study of Differences in Hybrid III Chest Deflections Due to Three- and Two-Point Belt Loadings.** Ann Arbor, MI, University of Michigan Transportation Research Institute. DOT-HS-807-275, February 1988.
737. Robbins, D.H., Lehman, R.J., Augustyn, K. **Prediction of Thoracic Injuries as a Function of Occupant Kinematics.** Proceedings of the 7th International Technical Conference On Experimental Safety Vehicles, Paris, France, June 5-8, 1979. Washington, D.C., U.S. Department of Transportation, National Highway Traffic Safety Administration, 374-83 (1979).
738. Robbins, D.H., Melvin, J.W., Stalnaker, R.L. **The Prediction of Thoracic Impact Injuries.** Proceedings of the 20th Stapp Car Crash Conference, Dearborn, MI, October 18-20, 1976, (Society of Automotive Engineers Proceedings No. P-66). Warrendale, PA, Society of Automotive Engineers, 2622-37 (1976).
739. **Roberson, M., Guill, F.C., Stokes, C., Lewis, L. Preliminary Analyses of Flail, Windblast and Tumble Problems and Injuries Associated with Usage of U.S. Navy Aircrew Automated Escape Systems (AAES).** Proceedings of the 19th Annual Symposium of the Survival and Flight Equipment Association, Las Vegas, NV, December 6-10, 1981. Van Nuys, CA, SAFE Asscociation, 25-29 (1982).

740. Roberts, A.K. Report of EUROSID 1989. Proceedings of the 12th International Technical Conference On Experimental Safety Vehicles, Goteborg, Sweden, May 29-June 1, 1989. Washington, D.C., U.S. Department of Transportation, National Highway Traffic Safety Administration, 743-52 (1989).
741. Roberts, C.C. Jr. Biomechanics Analysis of Ski Accidents Involving Bone Fractures. Presented at the Winter Annual Meeting of the American Society of Mechanical Engineers On Biomechanics in Sport—a 1987 Update, Boston, MA, December 13-18, 1987. New York, NY, American Society of Mechanical Engineers, 61-67 (1987).
742. Roberts, S.B. Head Injury [Mathematical Models for Predicting Head Motion and Injuries During Automobile Accidents]. IN: UCLA Motor Vehicle Safety Contract, September 1969. Los Angeles, CA, University of Southern California, 373-417 (1969).
743. Roberts, S.B. Intrusion of the Sternum into the Thoracic Cavity During Frontal Chest Impact and Injury Potential. IN: Aircraft Crashworthiness (Proceedings of a Symposium, Cincinnati, OH, October 6-8, 1975). Saczalski, Kenneth, Singley, George T. 3d, Pilkey, Walter D. And Huston, Ronald L., eds. Charlottesville, VA, University Press of Virginia, 253-71 (1975).
744. Rodden, B.E., Bowden, T.J., Reichert, J.K. An Algorithm for Determining the Head Injury Criterion (HIC) from Records of Head Acceleration. Presented at the International Congress and Exposition, Detroit, MI, February 28-March 4, 1983, (Society of Automotive Engineers Technical Paper No. 830469). Warrendale, PA, Society of Automotive Engineers, 1-17 (1983).
745. Roeder, L.F. Jr., DeLee, J.C. Femoral Head Fractures Associated with Posterior Hip Dislocation. Clin Orthop, 147, 121-30 (1980 Mar-Apr).
746. Rolsten, R.F., Haley, J.L. Jr. Improved Design Criteria for Crash Helmets. USAARL-86-11, May 1986.
747. Rorabeck, C.H., Rock, M.G., Hawkins, R.J., Bourne, R.B. Unilateral Facet Dislocation of the Cervical Spine. An Analysis of the Results of Treatment in 26 Patients. Spine, 12(1): 23-7 (1987 Jan-Feb).
748. Rothwell, W.S., Sperry, E.G. Footrests On Upward Ejection Seats. WADC-TR-52-208, September 1952.
749. Rotondo, G. Spinal Injury After Ejection in Jet Pilots: Mechanism, Diagnosis, Followup, and Prevention. Aviat Space Environ Med, 46(6), 842-8 (1975 Jun).

750. Rotondo, G. Survey On Biodynamic Response to Windblast in Ejections: Pathogenetic Mechanism, Analysis and Prevention of Injuries. IN: Biodynamic Response to Windblast. Neuilly-sur-Seine, France, Advisory Group On Aerospace Research and Development. AGARD-CP-170, B2-1-B2-9, (July 1975).
751. Rowe, K.W., Brooks, C.J. Head and Neck Injuries in Canadian Forces Ejections. Aviat Space Environ Med, 55(4), 313-5 (1984 Apr).
752. Roychoudhury, A., Kapur, R.R. Incidence of Spinal Disability Amongst IAF Pilots—Follow Up of 38 Cases. Aviat Med, 22, 21-4 (1978 Dec).
753. Ruff, S. Development and Construction of Pilot Ejector Seats in Germany from 1938-1945. DFVLR-FB-81-04, [In German with English Summary], February, 1981.
754. Rutherford, R.B. To Classify Thoracic Trauma. Med Trial Tech Q, 23(4), 361-75 (1977 Spring).
755. Sacco, W.J., Ashman, W.P., Swann, C.L., Sturdivan, L.M. Trauma Indices and Applications. June 1978.
756. Sacreste, J., Brun-Cassan, F., Fayon, A., Tarriere, C., Got, C., Patel, A. Proposal for a Thorax Tolerance Level in Side Impacts Based On 62 Tests Performed with Cadavers Having Known Bone Condition. Proceedings of the 26th Stapp Car Crash Conference, Ann Arbor, MI, October 20-21, 1982. (Society of Automotive Engineers Proceedings No. P-113). Warrendale, PA, Society of Automotive Engineers, 155-71 (1982).
757. Saczalski, K.J., States, J.D., Wagar, I.J., Richardson, E.Q. A Critical Assessment of the Use of Non-human Responding Surrogates for Safety System Evaluation. Proceedings of the 20th Stapp Car Crash Conference, Dearborn, MI, October 18-20, 1976, (Society of Automotive Engineers Proceedings No. P-66). Warrendale, PA, Society of Automotive Engineers, 159-187 (1976).
758. Sakamoto, S. Research History of Motorcycle Leg Protection. IN: Rider-Passenger Protection in Motorcycle Collisions, (Society of Automotive Engineers Proceedings No. SP-827). Warrendale, PA, Society of Automotive Engineers, 165-96 (1990).
759. Salerno, M.D., Brinkley, J.W., Orzech, M.A. Dynamic Response of the Human Head to +G(x) Impact. Proceedings of the 24th Annual Symposium of the Survival and Flight Equipment Association, San Antonio, TX, December 11-13, 1986. Van Nuys, CA, SAFE Association, 74-79 (1987).
760. Sances, A. Jr., Weber, R.C., Larson, S.J., Cusick, J.S., Myklebust, J.B., Walsh, P.R. Bioengineering Analysis of Head and Spine Injuries. CRC Crit Rev Bioeng, 5(2), 79-122 (1981 Feb).

761. **Sances, A., Yoganandan, N. Human Head Injury Tolerance. IN: Sances, Anthony Jr., ed. Mechanisms of Head and Spine Trauma. Goshen, NY, Aloray Publishers, 189-218 (1986).**
762. **Sandstedt, P. Experiences of Rocket Seat Ejections in the Swedish Air Force: 1967-1987. Aviat Space Environ Med, 60(4), 367-73 (1989 Apr).**
763. **Sarrailhi, S.R., Hearn, B.M. Simulated Head Impact on a Fibreglass Seat Back. Melbourne, Victoria, Australia, Department of Supply, Australian Defence Scientific Service, Aeronautical Research Laboratories, (Structures and Materials Note 342), June 1969.**
764. **Saul, R.A. State-of-the-Art Dummy Selection. Volume 2. Final Report. Washington, D.C., U.S. Department of Transportation, National Highway Traffic Safety Administration. DOT-HS-806-723, December 1984.**
765. **Saul, R.A. State-of-the-Art Dummy Selection. Volume 1. Final Report. Washington, D.C., U.S. Department of Transportation, National Highway Traffic Safety Administration. DOT-HS-806-722, December 1984.**
766. **Saul, R.A., Farson, M., Guenther, D.A. Development of a Component Level Head Impact Test Device. Proceedings of the 30th Stapp Car Crash Conference, San Diego, CA, October 27-29, 1986, (Society of Automotive Engineers Proceedings No. P-189). Warrendale, PA, Society of Automotive Engineers, 219-36 (1986).**
767. **Schall, D.G. Non-ejection Neck Injuries in High Performance Aircraft. IN: Neck Injury in Advanced Military Aircraft. Neuilly-sur-Seine, France, Advisory Group for Aerospace Research and Development (AGARD-CP-471), 2-1-2-10 (February 1990).**
768. **Schall, D.G. Non-ejection Cervical Spine Fracture Due to Defensive Aerial Combat Maneuvering in an RF-4C: a Case Report. Aviat Space Environ Med, 54(12), 1111-1116 (1983 Dec).**
769. **Schall, D.G. Non-ejection Cervical Spine Injuries Due to +Gz in High Performance Aircraft. Aviat Space Environ Med, 60(5), 445-56 (1989 May).**
770. **Schmid, W. An Aid for the Assessment of Biomechanical Values with High Scatter and Uncertain Limit Values. Proceedings of the 10th International Technical Conference on Experimental Safety Vehicles, Oxford, England, July 1-4, 1985. . Washington, D.C., U.S. Department of Transportation, National Highway Traffic Safety Administration, 543-8 (1985).**

771. Schneck, D.J. Aerodynamic Forces Exerted on an Articulated Human Body Subjected to Windblast. *Aviat Space Environ Med*, 49 (Sect.II), 183-190 (1978 Jan).
772. Schneck, D.J. Aerodynamic Forces Exerted on an Articulated Body Subjected to Windblast. Final Report June 14-August 20, 1976. AMRL-TR-76-109, December 1976.
773. Schneck, D.J. Aerodynamic Forces Exerted on an Articulated Human Body Subject to Windblast. AFOSR-TR-78-1147, June 1978.
774. Schneck, D.J. On the Aerodynamics of Windblast. AFOSR-TR-82-0031, November, 1981.
775. Schneck, D.J. **Studies of Limb-dislodging Forces Acting on an Ejection Seat Occupant.** AMRL-TR-78-103, January 1979.
776. Schneider, L.W., Foust, D.R., Bowman, B.M., Snyder, R.G., Chaffin, D.B., Abdelnour, T.A., Baum, J.K. Biomechanical Properties of the Human Neck in Lateral Flexion. Proceedings of the 19th Stapp Car Crash Conference, San Diego, CA, November 17-19, 1975, (Society of Automotive Engineers Proceedings No. P-62). Warrendale, PA, Society of Automotive Engineers, 455-85 (1975).
777. Schneider, L.W., King, A.I., Beebe, M.S. **Design Requirements and Specifications: Thorax—Abdomen Development Task. Interim Report. Trauma Assessment Device Development Program.** Washington, D.C., U.S. Department of Transportation, National Highway Traffic Safety Administration. DOT-HS-807-511, November 1989.
778. Schwartz, M. Comparative Study of Body Displacements in Both Humans and Anthropomorphic Dummies When Simultaneously Subjected to Controlled Vertical Impact Type Decelerations. NADC-AD-6808, April 1968.
779. Schwer, L.E. A Three Dimensional Large Displacement Transient Analysis of the Human Spine and Torso (Evaluating Ejection Injuries). [Ph.D. Thesis]. Chicago, IL, Illinois University, 1976.
780. Seemann, M.R., Muzzy, W.H., Lustick, L.S. Comparison of Human and Hybrid III Head and Neck Dynamic Response. Proceedings of the 30th Stapp Car Crash Conference, San Diego, CA, October 27-29, 1986, (Society of Automotive Engineers Proceedings No. P-189). Warrendale, PA, Society of Automotive Engineers, 291- 311 (1986).
781. Selke, D.J., Little, R.W., Hubbard, R.P., Slonim, A.R. Mechanical Properties of Lower Limb Tendons and Ligaments in Primates. AFAMRL-TR-82-56, July 1982.

782. Selke, D.J., Walsh, J.A., Little, R.W., Slonim, A.R. Morphology and Histology of Lower Limb Tendons and Ligaments in Primates. AFAMRL-TR-81-76, August 1981.
783. Severy, D.M., Brink, H.M., Baird, J.D. Backrest and Head Restraint Design for Rear-end Collision Protection. Presented at the Automotive Engineering Congress, Detroit, MI, January 8-12, 1968, (Society of Automotive Engineers Technical Paper No. 680079). New York, NY, Society of Automotive Engineers, 1-115 (1968).
784. Shaffer, J.T. Dynamic Principles for Seat Cushion Evaluation. Proceedings of the 9th Annual Symposium of the Survival and Flight Equipment Association, Las Vegas, NV, September 27-31, 1971. Van Nuys, CA, SAFE Association, 93-97, (1972).
785. Shaffer, J.T., Letscher, R.M. Sublethal Injury Patterns in the Baboon Restrained with a Three-Point Harness (-Gx Impact). AMRL-TR-76-76, February 1977.
786. Shaibani, S.J., Baum, H.M. Comparisons of the Thoracic Trauma Index with Other Models. *Accid Anal Prev*, 22(1), 35-45 (1990).
787. Shanahan, D.F. Basilar Skull Fracture in U.S. Army Aircraft Accidents [Helmet Design for Pilot Protection]. *Aviat Space Environ Med*, 54(7), 628-631 (1983 Jul).
788. Shanahan, D.F., Mastroianni, G.R. Spinal Injury in a U.S. Army Light Observation Helicopter. *Aviat Space Environ Med*, 55(1), 32-40 (1984 Jan).
789. Shanks, J.E., Thompson, A.L. Injury Mechanisms to Fully Restrained Occupants. Proceedings of the 23rd Stapp Car Crash Conference, San Diego, CA, October 17-19, 1979, (Society of Automotive Engineers Proceedings No. P-82). Warrendale, PA, Society of Automotive Engineers, 19-38 (1979).
790. Shannon, R.H. An Analysis of Injuries Incurred During Emergency Ejection/Extraction, Combat and Noncombat. Proceedings of the 7th Annual Symposium on National Flight Safety, Survival and Personal Equipment, Survival and Flight Equipment Association, Las Vegas, NV, October 27-30, 1969. Van Nuys, CA, SAFE Association, 546-558 (1969).
791. Shannon, R.H. The Decline in USAF Ejection Survival Rates. Proceedings of the 11th Annual Symposium of the Survival and Flight Equipment Association, Phoenix, AZ, October 7-11, 1973. Canoga Park, CA, SAFE Association, 137, 139-141 (1974).
792. Shannon, R.H. In-Flight Escape Experiences of Southeast Asia Prisoner of War Returnees. September 1974.

793. **Shannon, R.H. Operational Aspects of Forces On Man During Ejection/extraction Escape in the US Air Force, January 1, 1968-December 31, 1970. IN: Linear Acceleration of Impact Type. Neuilly-sur-Seine, France, Advisory Group for Aerospace Research and Development. AGARD-CP-88-71, A1-1-A1-8, June 1971.**
794. **Shannon, R.H., Munson, H.G. Spinal Injuries in Nonfatal USAF Aircraft Accidents, 1 January 1968-31 December 1972. Proceedings of the ?th Annual Meeting of the Aerospace Medical Association meeting, Las Vegas, NV, May 7-10, 1973.**
795. **Shannon, R.H. USAF Ejection Or Extraction Fatalities and Injuries, 1 Jan 1967 to 31 Dec 1970. Proceedings of Aerospace Pathology course, Walter Reed Army Medical Center, Washington, D.C., 23 Nov 1971.**
796. Shannon, R.H., Chunn, S.P., Detrick, W.R. Trends in USAF Aircrew Escape. Report for January 1, 1950-June 30, 1964. Norton AFB, CA, Deputy Inspector General for Inspection and Safety (Air Force), Life Sciences Division, June 30, 1964.
797. Shannon, R.H., Till, A.N. Jr. Combat Use of Life Support Systems in Southeast Asia. SAFE, 3, 13-16 (1969 Nov).
798. **Shannon, R.H., Till, A.N. Jr. SR-71 Ejection Experience. SAFE Engineering, 1, 3-6 (1971 4th Quarter).**
799. Sharda, P.C. Vertebral Fractures in Gnat Ejections. Aviat Med, 22, 25-28 (1978 Dec).
800. Shorr, R.M., Crittenden, M., Indeck, M., Hartunian, S.L., Rodriguez, A. Blunt Thoracic Trauma. Analysis of 515 Patients. Ann Surg, 206(2), 200-5 (1987 Aug).
801. **Siegel, J.H., Dalal, S.A., Burgess, A.R., Young, J.W. Pattern of Organ Injuries in Pelvic Fracture: Impact Force Implications for Survival and Death in Motor Vehicle Injuries. Accid Anal Prev, 22(5), 457-66 (1990 Oct).**
802. Simson, L.R. Jr. "Chin-sternum-heart Syndrome": Cardiac Injury Associated with Parachuting Mishaps. Aerosp Med, 42(11), 1214-7 (1971 Nov).
803. Sironi, V.A., Rampini, P.M., Guerrisi, E. Neurotraumatological Aspects in Ejected Pilots. IN: Aircrew Safety and Survivability (Ltd. to Combat Aircraft). Neuilly-sur-Seine, France, Advisory Group for Aerospace Research and Development. AGARD-CP-286, A12-1-A12-7, (October 1980).

804. Slattenschek, A., Tauffkirchen, W. **Critical Evaluation of Assessment Methods for Head Impact Applied in Appraisal of Brain Injury Hazards, in Particular in Head Impact On Windshields.** Proceedings of the International Automobile Safety Conference, Detroit, MI, May 13-15, 1970, (Society of Automotive Engineers Proceedings No. P-30). New York, NY, Society of Automotive Engineers, 1084-1112 (1970).
805. Slattenschek, A., Tauffkirchen, W., and Benedikter, G. **The Qualification of Internal Head Injury by Means of the Phantom Head and the Impact Assessment Methods.** Proceedings of the 15th Stapp Car Crash Conference, Coronado, CA, November 17-19, 1971, (Society of Automotive Engineers Proceedings No. P-39). New York, NY, Society of Automotive Engineers, 742-765 (1971).
806. Slobodnick, B. **A Correlation of Head Injury with Mechanical Forces Based On Helmet Damage Duplication.** IN: Models and Analogues for the Evaluation of Human Biodynamic Response, Performance and Protection. Neuilly-sur-Seine, France, Advisory Group for Aerospace Research and Development. AGARD-CP-253, A19-1-A19-12, (June 1979).
807. Slobodnick, B.A. **SPH-4 Helmet Damage and Head Injury Correlation.** USAARL-80-7, September 1980.
808. Slobodnick, B.A. **SPH-4 Helmet Damage and Head Injury Correlation.** Aviat Space Environ Med, 50(2), 139-146 (1979 Feb).
809. Smelsey, S.O. **Study of Pilots Who Have Made Multiple Ejections.** Aerosp Med, 41(5), 563-6, (1970 May).
810. Smiley, J.R. **R.C.A.F. Ejection Experience 1962-1966.** Aerosp Med, 39(6), 619-22 (1968 Jun).
811. Smith, D.E. **Analysis of the Initial Human Accelerator Runs to Provide Information for Use in Injury Prediction Model Development. I. Discussion.** (TN-3), June 27, 1974.
812. Smith, D.E. **Analysis of the Initial Human Accelerator Runs to Provide Information for Use in Injury Prediction Model Development. II. Calculation Procedures.** (TN-4), July 1, 1974.
813. Smith, D.E. **Mathematical and Statistical Considerations Underlying Development of an Impact Injury Model.** Annual Report No. 4619-R1, March 1973.
814. Smith, D.E. **Testing Proposed Head/Neck Models with the Data from the Initial Experiment.** (TN-5), July 3, 1974.

815. Smith, D.E., Aarons, D. Research on the Development of a Statistical Impact Acceleration Injury Prediction Model from -Gx Accelerator Runs. (TR-112-11), June 1982.
816. Smith, D.E., Gardner, R.L. A Study of Estimation Accuracy When Using a Logistic Model for Prediction of Impact Acceleration Injury. (TR-102-5), March 1978.
817. Smith, D.E., Peterson, J.J. A Monte Carlo Study of the Use of Auxiliary Information in the Development of an Impact Acceleration Injury Prediction Model. (TR-112-9), September 1981.
818. Smith, G.R. Relating Air Cushion Performance to Human Factors and Tolerance Levels—Human Volunteer Testing. Proceedings of the 5th International Technical Conference On Experimental Safety Vehicles, London, England, 1974. Washington, D.C., U.S. Department of Transportation, National Highway Traffic Safety Administration, 491-9 (1974).
819. Smith-Lagnese, S.D., Kazarian, L.E. The Correlation and Description of Windflail Injury Mechanisms in the Windblast Environment. Proceedings of the 20th Annual Symposium of the Survival and Flight Equipment Association, Las Vegas, NV, December 6-10, 1982. Van Nuys, CA, SAFE Association, 293-296 (1983).
820. Snively, G.G., Snively, S.A. Biomechanics of Head Protection. Proceedings of the Conference On Road Safety, Brussels, Belgium, 1968. Vol.1., Biomechanics of Accidents. A 3-(1-15) (1968).
821. Snyder, R.G., Snow, C.C. Fatal Injuries Resulting from Extreme Water Impact. AM-68-19, September 1968.
822. Snyder, R.G. Human Tolerance Limits in Water Impact. *Aerosp Med*, 36(10), 940-7 (1965 Oct).
823. Snyder, R.G., Chaffin, D.B., Schneider, L.W., Foust, D.R., Bowman, B. M., Abelnour, T.A., Baum, J.K. Basic Biomechanical Properties of the Human Neck Related to Lateral Hyperflexion Injury. Final Report, November 1, 1973-December 31, 1974. Ann Arbor, MI, University of Michigan, Highway Safety Research Institute. UM-HSRI-BI-75-4, April 1975.
824. Snyder, R.G., Chaffin, D.B., Foust, D.R. Bioengineering Study of Basic Physical Measurements Related to Susceptibility to Cervical Hyperextension-Hyperflexion Injury. Final Report, January 15, 1972-September 15, 1973. Ann Arbor, MI, University of Michigan, Highway Safety Research Institute. UM-HSRI-BI-75-6, September 1975.

825. Snyder, R.G., Snow, C.C., Young, J.W., Crosby, W.M., Price, G.T. Pathology of Trauma Attributed to Restraint Systems in Crash Impacts. *Aerosp Med*, 39(8), 812-29 (1968 Aug).
826. Snyder, R.G., Young, J.W., Snow, C.C. Experimental Impact Protection with Advanced Automotive Restraint Systems: Preliminary Primate Tests with Air Bag and Inertia Reel/Inverted-Y Yoke Torso Harness. Proceedings of the 11th Stapp Car Crash Conference, Anaheim, CA, October 10-11, 1967, (Society of Automotive Engineers Proceedings No. P-20). New York, NY, Society of Automotive Engineers, 271-85 (1967).
827. Solgaard, S. Classification of Distal Radius Fractures. *Acta Orthop Scand*, 56(3), 249-52 (1985 Jun).
828. Solgaard, S. Function After Distal Radius Fracture. *Acta Orthop Scand*, 59(1), 39-42 (1988 Feb).
829. Sorbie, C. The Broken Hip. *Can J Surg*, 28(5), 385-6, 395 (1985 Sep).
830. Specker, L.J. Flow Stagnation as an Advanced Windblast Protection Technique [For Ejection Seat Safety]. Proceedings of the 23rd Annual Symposium of the Survival and Flight Equipment Association, Las Vegas, NV, December 1-5, 1985. Van Nuys, CA, SAFE Association, 12-17 (1986).
831. Specker, L.J., Brinkley, J.W. Windblast Protection for Advanced Ejection Seats. IN: **Implications of Advanced Technologies for Air and Spacecraft Escape**. Neuilly-sur-Seine, France, Advisory Group for Aerospace Research and Development (AGARD-CP-472), 10-1-10-11 (February 1990).
832. Specker, L.J., Phillips, N.S. Application of Biodynamic Models to the Analysis of F-16 Canopy Birdstrike. IN: **Models and Analogues for the Evaluation of Human Biodynamic Response, Performance and Protection**. Neuilly-sur-Seine, France, Advisory Group for Aerospace Research and Development (AGARD-CP-253), A10-1-A10-12, (June 1979).
833. Spiegel, P.G., Mast, J.W., Cooperman, D.R., Laros, G.S. Triplane Fractures of the Distal Tibial Epiphysis. *Clin Orthop*, (188), 74-89 (1984 Sep).
834. St. Laurent, A., Szabo, T., Shewchenko, N., Newman, J.A. Design of a Motorcyclist Anthropometric Test Device. Proceedings of the 12th International Technical Conference on Experimental Safety Vehicles, Goteborg, Sweden, May 29-June 1, 1989. Washington, D.C., U.S. Department of Transportation, National Highway Traffic Safety Administration, 1308-16 (1989).

835. Stacoff, A., Kalin, X., Stussi, E. Torsional Movements of the Foot During Landing. *J. Biomech.*, 22(10), 1085, [ABSTRACT ONLY] (1989 Oct).
836. Stalnaker, R.L., Alem, N.M., Benson, J.B. Validation Studies for Head Impact Injury Model. Final Report July 1, 1973-August 31, 1975. Washington, D.C., U.S. Department of Transportation, National Highway Traffic Safety Administration. DOT-HS-802-566, September 1977.
837. Stalnaker, R.L., Lin, C.A. Application of the Mean Strain Criterion (MSC). Proceedings of the 12th International Workshop on Human Subjects for Biomechanical Research, Chicago, IL, November 5, 1984, 173-189 (1984).
838. Stalnaker, R.L., Lin, C.A., Guenther, D.A. The Application of the New Mean Strain Criterion (NMSC). Proceedings of International Research Committee on the Biokinetics of Impacts Bron, France, IRCOBI, 191-209 (June 1985).
839. Stalnaker, R.L., McElhaney, J.H., Roberts, V.L. A Mechanical Impedance Model for Head Injury Due to Linear Impacts. AMRL-TR-71-29 Paper No. 37, December 1971.
840. Stalnaker, R.L., McElhaney, J.H., Roberts, V.L. MSC Tolerance Curve for Human Head Impacts. (ASME Pap 71-WA/BHF-10), Contributed by the Biomechanics and Human Factors Division of the American Society of Mechanical Engineers for presentation at the ASME Winter Annual Meeting. Washington, D.C., November 28-December 2, 1971.
841. Stalnaker, R.L., Mohan, D. Human Chest Impact Protection Criteria. Proceedings of the 3rd International Conference on Occupant Protection, Troy, MI, July 10-12, 1974, (Society of Automotive Engineers Proceedings No. P-53). Warrendale, PA, Society of Automotive Engineers, 2341-52 (1974).
842. Stalnaker, R.L., Roberts, V.L., McElhaney, J.H. Side Impact Tolerance to Blunt Trauma. Proceedings of the 17th Stapp Car Crash Conference, Oklahoma City, OK, November 12-13, 1973, (Society of Automotive Engineers Proceedings No. P-51). Warrendale, PA, Society of Automotive Engineers, 377-408 (1973).
843. Stalnaker, R.L., Tarriere, C., Fayon, A., Walfisch, G., Balthazard, M., Masset, J., Got, C., Patel, A. Modification of Part 572 Dummy for Lateral Impact According to Biomechanical Data. Proceedings of the 23rd Stapp Car Crash Conference, San Diego, CA, October 17-19, 1979, (Society of Automotive Engineers Proceedings No. P-82). Warrendale, PA, Society of Automotive Engineers, 843-72 (1979).
844. Stapp, J.P. Biodynamics of Deceleration, Impact and Blast. IN: Randel, H.W., ed. *Aerospace Medicine*. 2nd ed. Baltimore, MD, Williams & Wilkins, 118-166 (1971).

845. **Stapp, J.P. Effects of Mechanical Force On Living Tissues. II. Supersonic deceleration and windblast. J Aviat Med, 27: 407-413 (1956 Oct).**
846. **States, J.D. Can Severity Index Curves Be Developed for Other Organ Systems and Tissue? Proceedings of the 15th Stapp Car Crash Conference, Coronado, CA, November 17-19, 1971, (Society of Automotive Engineers Proceedings No. P-39). New York, NY, Society of Automotive Engineers, 825-827 (1971).**
847. **States, J.D., Hight, P.V. Tolerance of Human Femur Derived from an Accidental Fall. Proceedings of the 26th Annual Conference of the American Association for Automotive Medicine, Ottawa, Ontario, Canada, October 4-6, 1982. Arlington Heights, IL, American Association for Automotive Medicine, 37-62 (1982).**
848. **States, J.D., Huelke, D.F., Dance, M., Green, R.N. Fatal Injuries Caused by Underarm Use of Shoulder Belts. J Trauma, 27(7): 740-745 (1987 Jul).**
849. **States, J.D., Ryon, D. Restraint Systems in Racing Accidents. Presented at the International Automotive Engineering Congress, Detroit, MI, January 13-17, 1969, (Society of Automotive Engineers Technical Paper No. 690246). New York, NY, Society of Automotive Engineers, 1-8 (1969).**
850. **Statistics of French Armee de L'Air Ejections 1970-1980. IN: Report On the Working Group On the Clinical and Biomedical Evaluation of Trauma and Fatalities Associated with Aircrew Ejection and Crash. Neuilly-sur-Seine, France, Advisory Group on Aerospace Research and Development. AGARD-AR-194, 3-5 (December 1984).**
851. **Stauf, W., de Vogel, D., Kasperowski, M. A New Data Acquisition and Analysis System for Vehicle Crash Tests Using On Line Data Transfer Via Fiber Optics. Presented at the Passenger Car Meeting & Exposition, Dearborn, MI, October 19-22, 1987, (Society of Automotive Engineers Technical Paper No. 871963). Warrendale, PA, Society of Automotive Engineers, 1987.**
852. **Stech, E.L., Payne, P.R. Dynamic Models of the Human Body (Joint NASA/USAF Study). AMRL-TR-66-157, November 1969.**
853. **Steedman, D.J. Severity of Free-fall Injury. Injury, 20(5), 259-61 (1989 Sep).**
854. **Stoll, A.M., Chianta, M.A., Piergallini, J.R. Heat Transfer Principles in Personal Protection Applications. Proceedings of the 15th Annual Symposium of the Survival and Flight Equipment Association, Las Vegas, NV, December 5-8, 1977. Canoga Park, CA, SAFE Association, 28-31 (1977).**
855. **Stoll, A.M., Piergallini, J.R., Chianta, M.A. Rocket Plume Burn Hazard. NADC-8008-60, January 1980.**

856. Stoppa, R., Ossart, J.L., Henry, X., Samarcq, B. Thoracic and Abdominal Injuries in Multiple Trauma. *Int Surg*, 62(1), 8-14 (1977 Jan).
857. Stuhmiller, J.H., Chuong, C.J., Phillips, Y.Y., Dodd, K.T. Computer Modeling of Thoracic Response to Blast. *J Trauma*, 28 (1 Suppl), S132-9 (1988 Jan).
858. Sturgeon, W.R. Canadian Forces Aircrew Ejection, Descent, and Landing Injuries, January 1, 1975-December 31, 1987. DCIEM-88-RR-56, January 1989.
859. Sturm, J.T., Hines, J.T., Perry, J.F. Jr. Thoracic Spinal Fractures and Aortic Rupture: a Significant and Fatal Association. *Ann Thorac Surg*, 50(6), 931-3 (1990 Dec).
860. Suraci, A.J. Distribution and Severity of Injuries Associated with Hip Dislocations Secondary to Motor Vehicle Accidents. *J Trauma*, 26(5), 458-60 (1986 May).
861. Sutherland, G.R., Driedger, A.A., Holliday, R.L., Cheung, H.W., Sibbald, W.J. Frequency of Myocardial Injury After Blunt Chest Trauma as Evaluated by Radionuclide Angiography. *Am J Cardiol*, 52(8), 1099-103 (1983 Nov 1).
862. Svennevig, J.L., Bue-Asperh Geiran, O.R., Vaage, J., Pillagram-Larsen, J., Fjeld, N.B., Birkeland, S. Prognostic Factors in Blunt Chest Trauma: Analysis of 652 Cases. *Ann Chir Gynaecol*, '75(1), 8-14 (1986).
863. Swearingen, J.J. Evaluation of Head and Face Injury Potential of Current Airline Seats During Crash Decelerations. AM 66-18, June 1966.
864. Swearingen, J.J. Evaluation of Various Padding Materials for Crash Protection. AM66-40, December 1966.
865. Swearingen, J.J. Tolerances of the Human Face to Crash Impact. AM-65-20, July 1965.
866. Symeonides, P.P. Some Observations On Compression Fractures of the Spine in Ejected Greek Pilots. IN: Linear Acceleration of Impact Type. Neuilly-sur-Seine, France, Advisory Group for Aerospace Research and Development. AGARD-CP-88-71, A6-1-A6-3. (June 1971).
867. Tadokorv, H. Load Measuring Method of Occupant's Leg on Motorcycle Collision. Proceedings of teh 11th International Technical Conference on Experimental Safety Vehicles, Washington, D.C., May 12-15, 1987. Washington, D.C., U.S. Department of Transportation, National Highway Traffic Safety Administration, 869-77 (1987).
868. Tardov, V.M. Human Endurance of Impact Angular Accelerations. Translated from *Aviats Kosmich Med* (Moscow), 2, 244-248 (1969).

869. Tennyson, S.A., King, A.I. A Biodynamic Model of the Human Spinal Column. IN: **Mathematical Modeling Biodynamic Response to Impact**, (Society of Automotive Engineers Proceedings No. SP-412). Warrendale, PA, Society of Automotive Engineers, 31-44 (1976).
870. Thibault, L., Bianchi, A., Galbraith, J., Gennarelli, T.A. **Physical Model Experiments of the Brain Undergoing Dynamic Loading. Presented at the Winter Annual Meeting of the American Society of Mechanical Engineers, Washington, D.C., November 14-19, 1982.** New York, NY, Society of Mechanical Engineers, 39-42 (1982).
871. Thibault, L., Gennarelli, T.A. **Brain Injury: a Research Initiative to Develop Improved Head Injury Tolerance Criteria. Final Report for 1982-89.** Washington, D.C., U.S. Department of Transportation, National Highway Traffic Safety Administration. DOT-HS-807-480, March 15, 1989.
872. Thibault, L., Gennarelli, T.A. **Biomechanics of Diffuse Brain Injuries.** Proceedings of the 10th International Technical Conference on Experimental Safety Vehicles, Oxford, England, July 1-4, 1985. Washington, D.C., U.S. Department of Transportation, National Highway Traffic Safety Administration, 79-85 (1989).
873. Thibault, L., Gennarelli, T.A., Margulies, S. **Animal, Physical and Analytical Models for Use in the Development of Improved Head Injury Criteria. Volume 1. Final Report 1982-1989.** Washington, D.C., U.S. Department of Transportation, National Highway Traffic Safety Administration. DOT-HS-807-481, March 1989.
874. Thomas, D.J., Jessop, M.E. **Experimental Head and Neck Injuries from Inertial Forces.** Proceedings of the 37th Annual Conference on Engineering in Medicine and Biology, 1984. Bethesda, MD, Alliance for Engineering in Medicine and Biology, 290 [ABSTRACT ONLY] (1984).
875. Tolonen, J., Santavirta, S., Kiviluoto, O., Lindqvist, C. **Fatal Cervical Spinal Injuries in Road Traffic Accidents.** Injury, 17(3), 154-8 (1986 May).
876. Tong, P., Eppinger, R., Marcus, J., Galbraith, C. **Finite Element Modeling of Head Injury Caused by Inertial Loading.** Proceedings of the 12th International Technical Conference on Experimental Safety Vehicles, Goteborg, Sweden, May 29-June 1, 1989. Washington, D.C., U.S. Department of Transportation, National Highway Traffic Safety Administration, 617-27 (1989).
877. Torvik, P.J. **An Analysis of the Pressure Wave Generated in Seated Spinal Impact.** AMRL-TR-71-29 Paper No. 23, 595-620 (December 1971).

878. Torz, J.S., Vigso, J.J., O'Neill, M.J. Sennett, B. The Epidemiologic, Pathologic, and Cinematographic Analysis of Football-Induced Cervical Spine Trauma. *Am J Sports Med*, 18, 50-7 (1990).
879. Townsend, M.A., McCammond, D., Lie, G. Response of Human and Anthropometric Model Skulls to Impact Loading. *Med Biol Eng*, 13(3), 405-413 (1975 May).
880. Trella, T.J., Kaniyantra, J.N. Occupant Response Sensitivity Analyses Using a Lumped Mass Model in Simulation of Car-to-Car Side Impacts. Proceedings of the 10th International Technical Conference on Experimental Safety Vehicles, Oxford, England, July 1-4, 1985. Washington, D.C., U.S. Department of Transportation, National Highway Traffic Safety Administration, 755-71 (1985).
881. Trosseille, X., Chamouard, F., Tarriere, C. Reconsideration of the HIC, Taking into Account the Skull Bone Condition Factor (SBCF): Limit of Head Tolerance in Side Impacts. Proceedings of the 32nd Stapp Car Crash Conference, Atlanta, GA, October 17-19, 1988, (Society of Automotive Engineers Proceedings No. P-215). Warrendale, PA, Society of Automotive Engineers, 29-34 (1988).
882. Tsai, H.C., Reddi, M.M. Computer Simulation of Human Thoracic Skeletal Response. Volume II. THORAX Programmer's and User's Manual. Final Report. 26 Jun 75-31 Jan 77. Washington, D.C., U.S. Department of Transportation, National Highway Traffic Safety Administration. DOT-HS-803-210, February 1977.
883. Tucker, W.L. Nature and Causes of Vertebral Fractures in F4 Aircraft Ejection. [Thesis]. AFIT/GE/EE/78-8, March 1978.
884. Tyndall, L.H., Carr, R.W. Analysis of Naval Aviation Head and Neck Injuries (1969-1978). 0249-78-81, May 1978.
885. Unterharnscheidt, F.J. About Boxing: Review of Historical and Medical Aspects. *Texas Rep Biol Med*, 28, 421-95, (Winter 1970).
886. Unterharnscheidt, F.J. Translational Versus Rotational Acceleration: Animal Experiments with Measured Input. Proceedings of the 15th Stapp Car Conference, Coronado, CA, November 17-19, 1971. (Society of Automotive Engineers Proceedings No. P-39). New York, NY, Society of Automotive Engineers, 767-70 (1971).
887. Unterharnscheidt, F., Ewing, C.L. Potential Relationship Between Human Central Nervous System Injury and Impact Forces Based On Primate Studies. IN: Models and Analogues for Evaluation of Human Biodynamic Response, Performance and Protection. Neuilly-sur-Seine, France, Advisory Group for Aerospace Research and Development. AGARD-CP-253, A18-1-A18-8 (1978).

888. Unterharnscheidt, F., Higgins, L.S. Traumatic Lesions of Brain and Spinal Cord Due to Nondeforming Angular Acceleration of the Head. *Tex Rep Biol Med*, 27(1), 127-66 (1969 Spring).
889. Upadhyay, S.S., Moulton, A., Burwell, R.G. Biological Factors Predisposing to Traumatic Posterior Dislocation of the Hip. A Selection Process in the Mechanism of Injury. *J Bone Joint Surg [Br]*, 67(2), 232-6 (1985 Mar).
890. USAF Ejection Experience, 1 January 1961-31 December 1962. (Study NR-37-63).
891. Van Ingen, C., Coltman, J.W. Investigation of Composite Materials for Manikin Skeletal Components, Small Business Innovation Research Phase 1. AAMRL-Tr-88-38, April 28, 1988.
892. Van Ingen-Dunn, C., Coltman, J.W., Kaleps, I. Skeletal Segment Development for an Advanced Manikin. *SAFE J*, 20, 35-41 (1990 Spring).
893. Vanderby, R. Jr., Bonifas, S.J., Hahn, E.E. Computer Analysis in Helmet Design [For Biodynamic Response of Head to Impact]. Proceedings of the 20th Annual Symposium of the Survival and Flight Equipment Association, Las Vegas, NV, December 6-10, 1982. Van Nuys, CA, SAFE Association, 27-30 (1982).
894. Verghese, C.A. Biodynamics of Aviation Stresses On the Vertebral Column. *Aviat Med*, 23, 39-40 (1979 Jun).
895. Verma, S.P., Roychoudhury, A. Aircraft Ejection Injury Patterns and Trends, IAF, 1957-1972. *JAMS India*, 57-64 (1973).
896. Verriest, J.P. Cinephotogrammetric Evaluation of Thoracic Deformation Due to Safety Belt Action During a Crash Test. Proceedings of a SPIE-International Society for Optical Engineering Conference, Biostereometrics '82, San Diego, CA, August 24-27, 1982. Bellingham, WA, SPIE, 246-256 (1983).
897. Verriest, J.P., Chapon, A., Trauchessec, R. Cinephotogrammetrical Study of Porcine Thoracic Response to Belt Applied Load in Frontal Impact—Comparison Between Living and Dead Subjects. Proceedings of the 25th Stapp Car Crash Conference, San Francisco, CA, September 28-30, 1981, (Society of Automotive Engineers Proceedings No. P-97). Warrendale, PA, Society of Automotive Engineers, 499-545 (1981).
898. Verriest, J.P., Chapon, A. Validity of Thoracic Injury Criteria Based On the Number of Rib Fractures. Proceedings of the 10th International Technical Conference On Experimental Safety Vehicles, Oxford, England, July 1-4, 1985. Washington, D.C., U.S. Department of Transportation, National Highway Traffic Safety Administration, 124-32 (1985).

899. **Versace, J. A Review of the Severity Index. Proceedings of the 15th Stapp Car Crash Conference, Coronado, CA, November 17-19, 1971, (Society of Automotive Engineers Proceedings No. P-39). New York, NY, Society of Automotive Engineers, 771-96 (1971).**
900. **Vetter, J.E. An Analysis of the Fatality Rate Data from "Jettison-canopy" and "Through-the-canopy" Ejections from Automated Airborne Escape Systems. Proceedings of the 19th Annual Symposium of the Survival and Flight Equipment Association, Las Vegas, NV, December 6-10, 1981. Van Nuys, CA, SAFE Association, 8-12 (1982).**
901. **Vetter, J.E., Herd, G.R. An Investigation of the Fatality Rates for Different Canopy Modes of Ejection. Proceedings of the 20th Annual Symposium of the Survival and Flight Equipment Association, Las Vegas, NV, December 6-10, 1982. Van Nuys, CA, SAFE Association, 207-211 (1983).**
902. **Vettes, B., Delahaye, R.P. Helicopter Accidents. IN: Physiopathology and Pathology of Spinal Injuries in Aerospace Medicine. Neuilly-sur-Seine, France, Advisory Group for Aerospace Research and Development. AGARD-AG-250(ENG)-2ND, February 1982.**
903. **Viano, D.C. Biomechanics of Head Injury—Toward a Theory Linking Head Dynamic Motion, Brain Tissue Deformation and Neural Trauma. Proceedings of the 32nd Stapp Car Crash Conference, Atlanta, GA, October 17-19, 1988, (Society of Automotive Engineers Proceedings No. P-215). Warrendale, PA, Society of Automotive Engineers, 1-20 (1988).**
904. **Viano, D.C. Biomechanical Responses and Injuries in Blunt Lateral Impact. Proceedings of the 33rd Stapp Car Crash Conference, Washington, D.C., October 4-6, 1989, (Society of Automotive Engineers Proceedings No. P-227). Washington, D.C., U.S. Department of Transportation, National Highway Traffic Safety Administration, 113-42 (1989).**
905. **Viano, D.C. Considerations for a Femur Injury Criterion. Proceedings of the 21st Stapp Car Crash Conference, New Orleans, LA, October 19-21, 1977, (Society of Automotive Engineers Proceedings No. P-73). Warrendale, PA, Society of Automotive Engineers, 445-73 (1977).**
906. **Viano, D.C. Evaluation of Biomechanical Response and Potential Injury from Thoracic Impact. Aviat Space Environ Med, 49 (1 Pt. 2), 125-35 (1978 Jan).**
907. **Viano, D.C. Experimental Investigation of Femoral Fracture. RP-GMR-2356, HS-020 416. Warren, MI, General Motors Research Laboratories, 1977.**
908. **Viano, D.C. Femoral Impact Response and Fracture. HS-030 744, 1980.**

909. Viano, D.C., Culver, C.C., Haut, R.C., Melvin, J.W., Bender, M., Culver, R.H., Levine, R.S. Bolster Impacts to the Knee and Tibia of Human Cadavers and an Anthropomorphic Dummy. Proceedings of the 22nd Stapp Car Crash Conference, Ann Arbor, MI, October 24-26, 1978, (Society of Automotive Engineers Proceedings No. P-77). Warrendale, PA, Society of Automotive Engineers, 401-28 (1978).
910. Viano, D.C., Culver, C.C., Evans, L., Frick, M., Scott, R. Involvement of Older Drivers in Multivehicle Side Impact Crashes. *Accid Anal Prev*, 22(2), 177-188 (1990 Apr).
911. Viano, D.C., Khalil, T.B. Investigation of Impact Response and Fracture of the Human Femur by Finite Element Modeling. IN: **Mathematical Modeling Biodynamic Response to Impact**, (Society of Automotive Engineers Publication No. SP-412). Warrendale, PA, Society of Automotive Engineers, 53-60 (1976).
912. Viano, D.C., Khalil, T.B. Plane Strain Analysis of a Femur Midsection. Proceedings of the 4th New England Bioengineering conference, New Haven, CT, May 7-8, 1976. Elmsford, NY, Pergamon Press, 45-48 (1976).
913. Viano, D.C., Lau, I.V., Andrzejak, D.V., Asbury, C. Biomechanics of Injury in Lateral Impacts. *Accid Anal Prev*, 21(6), 535-51 (1989 Dec).
914. Viano, D.C., Lau, I.V., Asbury, C., King, A.I., Begeman, P. Biomechanics of the Human Chest, Abdomen, and Pelvis in Lateral Impact. Proceedings of the 12th International Technical Conference on Experimental Safety Vehicles, Goteborg, Sweden, May 29-June 1, 1989. Washington, D.C., U.S. Department of Transportation, National Highway Traffic Safety Administration, 943-50 (1989).
915. Viano, D.C., Lau, V.K. Role of Impact Velocity and Chest Compression in Thoracic Injury. *Aviat Space Environ Med*, 54(1), 16-21 (1983 Jan).
916. Viano, D.C., Lau, I.V. Thoracic Impact: a Viscous Tolerance Criterion. Proceedings of the 10th International Technical Conference on Experimental Safety Vehicles, Oxford, England, July 1-4, 1985. Washington, D.C., U.S. Department of Transportation, National Highway Traffic Safety Administration, 104-14 (1985).
917. Viano, D.C., Lau, I.V. A Viscous Tolerance Criterion for Soft Tissue Injury Assessment. *J Biomech*, 21(5), 387-399 (1988).
918. Viano, D.C., Melvin, J.W., McCleary, J.D., Madeira, R.G., Shee, T.R., Horsch, J.D. Measurement of Head Dynamics and Facial Contact Forces in the Hybrid III Dummy. Proceedings of the 30th Stapp Car Crash Conference, San Diego, CA, October 27-29, 1986, (Society of Automotive Engineers Proceedings No. P-189). Warrendale, PA, Society of Automotive Engineers, 269-89 (1986).

919. Viano, D.C., Warner, C.Y. Thoracic Impact Response of Live Porcine Subjects. Proceedings of the 20th Stapp Car Crash Conference, Dearborn, MI, October 18-20, 1976, (Society of Automotive Engineers Proceedings No. P-66). Warrendale, PA, Society of Automotive Engineers, 731-65 (1976).
920. Voge, V., Borowsky, M.S. The United States Navy's Injury Experience in Aircraft Mishaps. Proceedings of the 19th Annual Symposium of the Survival and Flight Equipment Association, Las Vegas, NV, December 6-10, 1981. Van Nuys, CA, SAFE Association, 248-251 (1982).
921. Voge, V.M., Miller, A. Selected Aeromedical Factors in U.S. Navy Combat-type Aircraft Mishaps. IN: Aircrew Safety and Survivability (Ltd. To Combat Aircraft). Neuilly-sur-Seine, France, Advisory Group for Aerospace Research and Development. AGARD-CP-286, A9-1-A9-5, (October 1980).
922. von Gierke, H.E. Biodynamic Models and Their Applications. AMRL-TR-71-51, 1971.
923. von Gierke, H.E., ed. Models and Analogues for the Evaluation of Human Biodynamic Response, Performance and Protection. Neuilly-sur-Seine, France, Advisory Group for Aerospace Research and Development. AGARD-CP-253, June 1979. [Partly in English, Partly in French].
924. von Gierke, H.E., Brinkley, J.W. Human Crashworthiness and Crash Load Limits. AD-P005814, December 1988.
925. von Gierke, H.E., Kaleps, I. Biodynamic Motion and Injury Prediction. Separata Revista Portuguesa Medicina Militar, 33(1), 1-3 (1985).
926. Vulcan, A.P., King, A.I. Nakamura, G.S. Effects of Bending on the Vertebral Column During +Gz Acceleration. Aerospace Medicine, 41, 294-300 (1970).
927. Vyrnwy-Jones, P. A review of Army Air Corps helicopter accidents, 1971-1982. Aviat Space Environ Med, 56(5), 403-9 (1985 May).
928. Walfisch, G., Chamouard, F., Lestrelin, D., Tarriere, C., Brun-Cassan, F., Mack, P., Got, C., Guillon, F., Patel, A., Hureau, J. Predictive Functions for Thoracic Injuries to Belt Wearers in Frontal Collisions and Their Conversion into Protection Criteria. Proceedings of the 29th Stapp Car Crash Conference, Washington, D.C., October 9-11, 1985, (Society of Automotive Engineers Proceedings No. P-167). Warrendale, PA, Society of Automotive Engineers, 49-68 (1985).

929. Wall, J., Lowne, R.W., Harris, J. The Determination of Tolerable Loadings for Car Occupants in Impacts. United Kingdom, Department of the Environment, Transport and Road Research. 1976.
930. Walsh, M.J., Kelleher, B.J., Severin, C.M. Head and Neck Injuries in Human Cadavers from Lateral Impacts. Proceedings of the 10th International Technical Conference on Experimental Safety Vehicles, Oxford, England, July 1-4, 1985. Washington, D.C., U.S. Department of Transportation, National Highway Traffic Safety Administration, 186-98 (1985).
931. Walz, F.H., Sprenger, H.J., Niederer, P.F. Severely and Fatally Injured Rear Seat Car Passengers (OASIS > 2) in Switzerland During 1976. Proceedings of the 22nd Annual Conference of American Association for Automotive Medicine and the 7th International Association for Accident and Traffic Medicine Conference, Ann Arbor, MI, July 10-14, 1978. Morton Grove, IL, American Association for Automotive Medicine, 129-139 (1978).
932. Wang, J.T. Analytical Studies of Injury Criteria for the Thorax. *J Biomech Eng*, 111(2), 128-35 (1989 May).
933. Ward, C.C. Finite Element Models of the Head and Their Use in Brain Injury Research. Proceedings of the 26th Stapp Car Crash Conference, Ann Arbor, MI, October 20-21, 1982, (Society of Automotive Engineers Proceedings No. P-113). Warrendale, PA, Society of Automotive Engineers, 71-85 (1982).
934. Ward, C.C. A Head Injury Model. IN: Models and Analogues for the Evaluation of Human Biodynamic Response, Performance and Protection. Neuilly-sur-Seine, France, Advisory Group for Aerospace Research and Development (AGARD-CP-253), A17-1-A17-12, (June 1979).
935. Ward, C.C., Chan, M., Nahum, A.M. Intracranial Pressure: a Brain Injury Criterion. Proceedings of the 24th Stapp Car Crash Conference, Troy, MI, October 15-17, 1980, (Society of Automotive Engineers Proceedings No. P-88). Warrendale, PA, Society of Automotive Engineers, 163-85 (1980).
936. Ward, C.C., Nikravesh, P.E., Thompson, R.B. Biodynamic Finite Element Models Used in Brain Injury Research. *Aviat Space Environ Med*, 49 (1 Pt. 2), 136-42 (1978 Jan).
937. Warner, C.Y., Strother, C.E., Woolley, R.L. Application of Kinematic Concepts to Side Impact Injury Analysis. Presented at the International Congress & Exposition, Detroit, MI, February 26-March 2, 1990, (Society of Automotive Engineers Technical Paper No. 900375). Warrendale, PA, Society of Automotive Engineers, 1-12 (1990).

938. **Warner, C.Y., Wille, M.G., Brown, S.R., Nilsson, S., Mellander, H., Koch, M. A Load Sensing Face Form for Automotive Collision Crash Dummy Instrumentation. IN: Passenger Comfort, Convenience and Safety: Test Tools and Procedures, (Society of Automotive Engineers Proceedings No. P-174). Warrendale, PA, Society of Automotive Engineers, 85-96 (1986).**
939. Waterbury, R.C. "Little Dummy" Tests Crash Protection. InTech, 37(3), 82 (1990 Mar).
940. Weaver, J.K. Skiing-related Injuries to the Shoulder. Clin Orthop, (216), 24-8 (1987 Mar).
941. Webb, M.G. Jr., Gray, R.F. A New Method of Protection Against the Effects of Acceleration On the Cardiovascular Systems. Am J Cardiol, 6, 1070-1077 (1960).
942. Weinberg, C.J. U.S. Air Force Exploratory Development in Impact Injury Prediction and Protection. Proceedings of the 8th Annual Symposium of the Survival and Flight Equipment Association, Las Vegas, NV, September 28-October 1, 1970. Newhall, CA, SAFE Association, 493-512 (1970).
943. Weiss, M.S., Berger, M.D. Neurophysiological Effects of -X Impact Acceleration. Aviat Space Environ Med, 54(11), 1023-1027 (1983 Nov).
944. Weiss, M.S., Guccione, S.J. Jr., Watkins, T.A. A Kinematic/dynamic Model for Prediction of Neck Injury During Impact Acceleration. IN: Neck Injury in Advanced Military Aircraft. Neuilly-sur-Seine, France, Advisory Group for Aerospace Research and Development (AGARD-CP-471), 11-1-11-6 (February 1990).
945. Welbourne, E.R., Ramet, M., Zarebski, M. A Comparison of Human Facial Fracture Tolerance with the Performance of a Surrogate Test Device. Proceedings of the 12th International Technical Conference on Experimental Safety Vehicles, Goteborg, Sweden, May 29-June 1, 1989. Washington, D.C., U.S. Department of Transportation, National Highway Traffic Safety Administration, 603-3 (1989).
946. Wells, R.P., Bishop, P.J., Stephens, M. Neck Loads During Head-First Collisions in Ice Hockey: Experimental and Simulation Results. Int J Sport Biomech, 3, 432-42 (1987).
947. White, A.A.3d, Panjabi, M.M. Clinical Biomechanics of the Spine, 2nd ed. Philadelphia, PA: J.B. Lippincott, (1990).
948. **White, R.P. Jr. The Development of a Dynamic Human Analog. Proceedings of the 11th International Technical Conference on Experimental Safety Vehicles, Washington, D.C., May 12-15, 1987. Washington, D.C., U.S. Department of Transportation, National Highway Traffic Safety Administration, 336-46 (1987).**

949. **White, Richard P., Jr. ADAM—the Physical Being. Proceedings of the 25th Annual Symposium of the Survival and Flight Environment Association, Las Vegas, NV, November 16-19, 1987. Newhall, CA, SAFE Association, 141-149 (1987).**
950. **White, R.P. Jr., Bartol, A.M. ADAM: the Next Step in Development of the True Human Analog. SAFE J, 17(1), 50-7 (1987).**
951. **White, R.P. Jr., Gustin, T.W. The Application of a New Data Recovery System for Automotive/motorcycle Dynamic Testing. Proceedings of the 12th International Technical Conference on Experimental Safety Vehicles, Goteborg, Sweden, May 29-June 1, 1989. Washington, D.C., U.S. Department of Transportation, National Highway Traffic Safety Administration, 1372-83 (1989).**
952. **White, R.P., Gustin, T.W., Tyler, M.C. Preliminary Design of a Limb Restraint Evaluator. AFAMRL-TR-84-042, December 1984.**
953. **White, R.P. Jr., Lawrence, R.D. A New High-fidelity Human Analog for Ejection Testing. SAFE J, 15, 30-41 (1985 Summer).**
954. **White, R.P. Jr., Murphy, B.P. The Design Evolution of the Mechanical Analog of the Human Dynamic Spine/viscera. Proceedings of the 24th Annual Symposium of the Survival and Flight Equipment Association, San Antonio, TX, December 11-13, 1986. Newhall, CA, SAFE Association, 205-211 (1987).**
955. **Wiechel, J.F., Bell, S., Pritz, H., Guenther, D.A. Enhancement of the Hybrid III Dummy Thorax. Proceedings of the 29th Stapp Car Crash Conference, Washington, D.C., October 9-11, 1985, (Society of Automotive Engineers Proceedings No. P-167). Warrendale, PA, Society of Automotive Engineers, 147-58 (1985).**
956. **Wiechel, J.F., Guenther, D.A. Two-dimensional Thoracic Modeling Considerations. IN: Side Impact: Injury Causation and Occupant Protection, (Society of Automotive Engineers Proceedings No. SP-769). Warrendale, PA, Society of Automotive Engineers, 133-50 (1989).**
957. **Willems, G. A Detailed Evaluation of the ATA Angular Motion Sensor in Realistic Simulated Crash Environments in Proceedings of the 35th Stapp Car Crash Conference, San Diego, CA, November 18-20, 1991. (Society of Automotive Engineers Proceedings No. P-251). Warrendale, PA, Society of Automotive Engineers, 334 (1991).**
958. **Williams, J., Belytschko, T. A Dynamic Model of the Cervical Spine and Head. AFAMRL-TR-81-5, November, 1981.**

959. Willke, D.T., Monk, M.W., Kaniyantra, J.N. Side Impact Subsystem Thoracic Impactor Evaluation. Proceedings of the 12th International Technical Conference On Experimental Safety Vehicles, Goteborg, Sweden, May 29-June 1, 1989. Washington, D.C., U.S. Department Of Transportation, National Highway Traffic Safety Administration, 1043-55 (1989).
960. Winkler, E.R., Johnson, G.L. F/A-18 Foot Strikes—An Update [During Ejection Process]. SAFE J, 10, 11-14 (1980 Fall).
961. Winqvist, P.G., Stumm, P.W., Hansen, R. Crash Injury Experiments with the Monorail Decelerator. AFFIC-TR-53-7, April 1953.
962. Wise, C.S., Rizzoli, H.V. Herniation of the Lumbar Intervertebral Disc. Bull Rheum Dis, 10(9), 219-222 (1960 May).
963. Wismans, J., Philippens, M., van Oorschot, E., Kallieris, D., Mattern, R. Comparison of Human Volunteer and Cadaver Head-neck Response in Frontal Flexion. Proceedings of the 31st Stapp Car Crash Conference, New Orleans, LA, November 9-11, 1987, (Society of Automotive Engineers Proceedings No. P-202). Warrendale, PA, Society of Automotive Engineers, 1-13 (1987).
964. Wismans, J., Spenny, C.H., Performance Requirements for Mechanical Neck in Lateral Flexion. Proceedings of the 27th Stapp Car Crash Conference, San Diego, CA, October 17-19, 1983. (Society of Automotive Engineers Proceedings No. P-134). Warrendale, PA, Society of Automotive Engineers, 137-48, (1983).
965. Wismans, J., van Oorschot, E., Woltring, J.H. Omni-directional Human Head-neck Response. Proceedings of the 30th Stapp Car Crash Conference, San Diego, CA, October 27-29, 1986, (Society of Automotive Engineers Proceedings No. P-189). Warrendale, PA, Society of Automotive Engineers, 313-31 (1986).
966. Worland, R.L., Dick, H.M. Transnavicular Perilunate Dislocations. J Trauma, 15(5), 407-12 (1975 May).
967. Yoganandan, N., Maiman, D.J., Pintar, F.A., Sances, A. Jr., Chintapalli, K., Unger, G.F. Cervical Spine Injuries from Motor Vehicle Accidents. J Clin Eng, 15(6), 505-513 (1990 Nov-Dec).
968. Yoganandan, N., Pintar, F., Chintapalli, K., Reinartz, J., Sances, A. Jr. Biomechanical and CT Analysis of Triplanar Facial Strut Trauma Following Steering Wheel Impact. J Biomech, 22(10), 1105 [ABSTRACT ONLY] (1989).

969. Yoganandan, N., Pintar, F., Sances, A.Jr., Harris, G., Chintapalli, K., Myklebust, J., Schmaltz, D., Reinartz, J., Kalbfleisch, J., Larson, S. Steering Wheel-induced Facial Trauma. Proceedings of the 32nd Stapp Car Crash Conference, Atlanta, GA, October 17-19, 1988, (Society of Automotive Engineers Proceedings No. P-215). Warrendale, PA, Society of Automotive Engineers, 45-69 (1988).
970. **Yoganandan, N., Ray, G., Sances, A. Jr., Pintar, F.A., Myklebust, J.B., Maiman, D.J., Myers, T.J. Assessment of Traumatic Failure Load and Microfailure Load in an Intervertebral Disc Desegment. Presented at the Winter Annual Meeting of the American Society of Mechanical Engineers, 1985 Advances in Bioengineering, Miami Beach, FL, November 17-22, 1985. New York, NY, American Society of Mechanical Engineers, 130-131 (1985).**
971. Yoganandan, N., Sances, A. Jr., Pintar, F. Biomechanical Evaluation of the Axial Compressive Responses of the Human Cadaveric and Manikin Necks. J Biomech Eng, Trans ASME, 111(3), 250-5 (1989 Aug).
972. Zingg, E.J., Casanova, G.A., Isler, B., Sohn, M. Pelvic Fractures and Traumatic Lesions of the Posterior Urethra. Eur Urol, 18(1), 27-32 (1990).

APPENDIX B - OUTLINE SUMMARY OF ANALYSIS OF USAF EJECTION SYSTEM EXPERIENCE SINCE 1975 (SELECTED AIRCRAFT)

1.
 - 620 ejections from all F-4, F-111 and ACES II ejection seat equipped aircraft (A-10, F-15, F-16, & B-1B, including one B-1A pod separation) since 1975.
 - 101 crewmembers ejected without reported injury (16.3%)
 - 394 crewmembers ejected with minimal, minor or no injuries (63.5%)
 - 126 crewmembers ejected, but were killed (20.3%)
 - 100 crewmembers ejected and survived with major injuries (16.1%)

2.
 - 1873 injuries reported, ranging from minor to fatal
 - plus 101 "no injury" entries in data base.
 - classified subjectively according to two rating scales, by Escape Phase and a combined scale. An override mechanism was also provided. "Results" are the reported number of injuries per category.

A. MINIMUM INJURY SEVERITY	RESULTS
0 - No injury	101
1 - Minor abrasions/contusion, etc.	666
2 - Minor lacerations, digital fractures, sprains, etc.	499
3 - Non incapacitating fractures, internal injuries, etc.	202
4 - Incapacitating fracture, internal injuries, etc.	212
5 - Lethal or potentially lethal injuries	294

B. MINIMUM OPERATIONAL IMPAIRMENT	RESULTS
0 - No impairment, no immediate care needed	981
1 - Minimal impairment, no immediate care needed	249
2 - Needs first aid quickly, capable after stabilization	210
3 - Severely impaired by injury, capability doubtful without help	36
4 - Nearly helpless, requires help to survive	90
5 - Helpless, unconscious or dead	408

C. **ESCAPE PHASE** - an attempt was made to assign the injury to one of eight phases during the escape sequence. (Although most of the injuries included adequate phase of occurrence information, categorization on a "most likely" basis was required for some injuries.)

ESCAPE PHASE	RESULTS
1. Initiation - events prior to ejection sequence start	43
2. Pathway Clearance - events prior to seat movement	1
3. Ejection - seat movement up rails	400
4. Emergence - insertion into environment outside cockpit	225
5. Man-Seat Separation - initial separation and subsequent encounter	47
6. Parachute Deployment - canopy establishment, opening shock	171
7. Descent - Events from opening shock to PLF	6
8. Ground Encounter - Events from PLF to stabilization	860
Uk. Unknown category for those injuries so marked	110

D. An **INJURY SIGNIFICANCE RATING (ISR)** was compiled by multiplying the Injury Severity by the Operational Impairment. The result was a form of prioritization marker for estimating importance of injury based on the two parameters.

ISR	RESULTS
0	981
2	227
3	22
4	56
6	153
8	2
9	14
10	1
12	35
16	76
20	113
25	294

E. In order to mark certain injuries known to be aeromedically important that are not otherwise medically or operationally significant, such as vertebral compression fractures, an override rating (ORR) was provided to mark certain injury categories that would otherwise submerge into the other less important injuries.

ORR	RESULTS
0	761
2	162
3	36
4	50
6	275
8	2
9	29
10	1
12	36
14	1
15	138
16	76
20	113
25	294

Principal changes:

Vertebral Compression fractures	-	0, 3 or 6 to 15
Knee sprain/strain	-	4 to 9
Neck sprain/strain	-	2 to 6
Back sprain/strain	-	2 to 6
Foot sprain/strain	-	0 to 4
Shoulder sprain/strain	-	2 to 3

F. The USAF Data provided an overall injury assessment for each ejected crewmember in a 5 category system. "Results" are the crewmembers per category.

INJURY CATEGORY	RESULTS
None	101
Minimal	225
Minor	68
Major	100
Fatal	126

3. SELECTION OF MOST SIGNIFICANT INJURIES FROM DATA BASE.

- Database searched to exclude minor abrasions and contusions and other non-significant injuries by requesting a tabulation of Anatomical Part and Injury Type where the override rating was greater than 2. This resulted in the exclusion of 923 entries from the original 1974.
- The resulting tabulation was reviewed to combine injuries where different terminology was used to describe the same anatomical part, (i.e. "C - 2, 3, 4" and "neck" were considered the same).
- The serious injuries reported from the 620 USAF Ejections are arranged in rough anatomical order with the number of occurrences of each type.

A. SERIOUS INJURIES (620 Ejections)

- Head - Skull fracture - 58 (includes 13 basilar skull fractures)
- Brain - 29 serious injuries (includes 9 concussion/amnesia)
- Neck - 10 cervical compression fractures
 - 28 cervical fractures
 - 65 cervical sprain/strains
- Thoracic Spine - 105 compression fractures
 - 22 fracture
 - 9 sprain/strains
- Shoulder - 16 fracture/dislocations
 - 11 sprain/strains
- Upper Arm - 27 fractures
- Elbow - 1 dislocation
- Lower Arm - 27 fractures
 - 2 sprain/strains
- Wrist - 3 fractures
- Ribs - 44 fractures
- Lumbar Spine - 30 compression fractures
 - 11 fractures
 - 8 sprain/strains
- Pelvis/Sacroiliac - 15 fractures
- Upper Leg - 19 fractures
 - 1 sprain/strain
- Lower Leg - 31 fractures
 - 15 sprain/strains
- Knee - 15 sprain/strains
- Ankle - 7 fractures
 - 10 sprain/strains
- Other - 10 body hypothermia
 - 36 eye contusions
 - 39 facial lacerations
 - 36 extremity amputations
 - 18 inguinal contusions
 - 7 concussions
 - 15 heart lacerations
- Back - 56 sprain/strains

- Of the 126 ejected crewmember fatalities, most were killed by ground impact at high speed and had multiple severe injuries. The above search procedures were performed with the additional exclusion of the fatalities and the resulting tabulation was as follows:

B. SERIOUS INJURIES (WITHOUT THE 126 FATALITIES)

- Head** - 1 skull fracture (includes 1 basilar skull fractures)
 - Brain** - 12 serious injuries (includes 9 concussion/amnesia)
 - Neck** - 6 cervical compression fractures
 - 2 cervical fractures
 - 65 cervical sprain/strains
 - Thoracic Spine** - 98 compression fractures
 - 3 fractures
 - 9 sprain/strains
 - Shoulder** - 9 fracture/dislocations
 - 10 sprain/strains
 - Upper Arm** - 9 fractures
 - Lower Arm** - 7 fractures
 - 1 sprain/strain
 - Wrist** - 1 fracture
 - Ribs** - 4 fractures
 - Lumbar Spine** - 27 compression fractures
 - 1 fracture
 - 8 sprain/strains
 - Pelvis/Sacroiliac** - 2 fractures
 - Upper Leg** - 4 fractures
 - 1 sprain/strain
 - Lower Leg** - 5 fractures
 - Knee** - 15 sprain/strains
 - Ankle** - 4 fractures
 - 10 sprain/strains
 - Other** - 8 body hypothermia
 - 33 eye contusions/hemorrhage
 - 34 facial lacerations
 - no extremity amputations
 - 17 inguinal contusions/abrasions
 - 7 concussions
 - no heart lacerations
- Back** - 56 sprain/strains

4. Serious Injury Occurrence During Various Phases of Escape

The following is a tabulation of the more serious injuries that occurred during each of the 8 phases of escape, and an unknown category, produced using the above selection criterion. It becomes quickly apparent that some of the escape phases have greater serious injury causation potential than others. An additional tabulation was done excluding the injuries caused by the fatalities and has been included after the original tabulation.

TABLE B-1 - SERIOUS INJURY TABULATION EXCLUDING 126 FATALITIES

1. INITIATION PHASE					3. EJECTION - CONT'D				
Anatomical Part	Injury Type	Number of Injuries	Injury Category	Rating	Anatomical Part	Injury Type	Number of Injuries	Injury Category	Rating
Body	Multiple Inj	1	Fatal	25	Jaw	Fracture	1	Fatal	6
Body Multiple	Burn 1st Degree	1	Fatal	4	Jaw	Sprain/Strain	1	Major	3
Clavicle	Fracture	1	Fatal	3	Knee	Sprain/Strain	1	Minor	9
Face	Burn 2nd Degree	2	Fatal	4	L-01	Dislocation	1	Fatal	20
Face	Burn 2nd Degree	1	Major	4	L-01	Fracture	2	Fatal	15
Face	Burn 2nd Degree	1	Minor	4	L-01	Fracture	11	Major	15
Foot	Sprain/Strain	1	Minor	4	L-0i	Sprain/Strain	1	Minor	6
Hand	Burn 3rd Degree	1	Fatal	4	L-01	Sprain/Strain	2	Minimal	6
Liver	Laceration	1	Fatal	25	L-02	Fracture	2	Major	15
Neck	Burn 2nd Degree	1	Fatal	4	L-02	Fracture	1	Minimal	15
Neck	Burn 2nd Degree	1	Major	4	L-02	Sprain/Strain	1	Minimal	6
Neck	Burn 2nd Degree	1	Minor	4	L-02,4	Fracture	1	Major	15
Neck	Burn 3rd Degree	1	Fatal	6	L-04	Sprain/Strain	1	Minimal	6
Ribs	Fracture	1	Fatal	6	L-05	Sprain/Strain	1	Minimal	6
Skull	Fracture	1	Fatal	20	Leg Lower	Fracture	1	Fatal	16
Skull Basal	Fracture	1	Fatal	20	Leg Lower	Fracture	1	Major	16
Sternum	Fracture	1	Fatal	6	Leg Lower	Sprain/Strain	1	Minimal	4
Tibia Fibula	Fracture	1	Fatal	16	Neck	Fracture	1	Major	15
					Neck	Sprain/Strain	4	Major	6
					Neck	Sprain/Strain	1	Minor	6
					Neck	Sprain/Strain	31	Minimal	6
					Ribs	Fracture	1	Fatal	6
					Ribs	Fracture	1	Major	6
					Sacroiliac	Sprain/Strain	1	Minimal	6
					Scapula	Dislocation	1	Major	6
					Shoulder	Fracture/Disloc	1	Major	6
					Shoulder	Sprain/Strain	3	Minimal	3
					Skull	Fracture	1	Fatal	20
					Spinal Cord	Contusion	1	Fatal	20
					Sternum	Fracture	1	Major	6
					T-01	Fracture	1	Major	15
					T-02	Stretching	1	Major	14
					T-03	Fracture	12	Major	15
					T-03,4,5,6	Sprain/Strain	1	Minimal	6
					T-04	Fracture	2	Major	15
					T-04,5	Fracture	1	Major	15
					T-05	Fracture	2	Fatal	15
					T-05	Fracture	4	Major	15
					T-05 Cord Inj	Fracture/Contus	1	Major	25
					T-06	Fracture	2	Fatal	15
					T-06	Fracture	3	Major	15
					T-06	Sprain/Strain	2	Minimal	6
					T-07	Fracture	5	Major	15
					T-07	Sprain/Strain	1	Minimal	6
					T-07,9,10	Fracture	1	Major	15
					T-08	Dislocation	1	Fatal	20
					T-08	Fracture	7	Major	15
					T-09	Fracture	1	Fatal	15
					T-09	Fracture	4	Major	15
					T-10	Fracture	1	Fatal	15
					T-10	Fracture	5	Major	15
					T-11	Fracture	10	Major	15
					T-11,12	Fracture	1	Major	15
					T-12	Fracture	1	Fatal	15

3. EJECTION - CONT'D

Anatomical Part	Injury Type	Number of Injuries	Injury Category	Rating
T-12	Fracture	7	Major	15
T-12	Fracture	1	Minimal	15
Thorax	Sprain/Strain	1	Minimal	6
Tibia Fibula	Fracture	1	Fatal	16
Ulna	Fracture	1	Major	6

4. EMERGENCY

Anatomical Part	Injury Type	Number of Injuries	Injury Category	Rating
Abdomen	Evisceration	1	Fatal	25
Abdomen	Laceration	1	Fatal	9
Arm Upper	Amputation	2	Fatal	25
Arm Upper	Fracture	1	Fatal	6
Arm Upper	Fracture	1	Major	6
Arm Upper	Sprain/Strain	1	Minimal	3
Back	Sprain/Strain	2	Minimal	6
Body (Fatal)	Multiple Inj	1	Fatal	25
Brachial	Fracture	1	Fatal	6
Brain	Contusion	1	Fatal	20
Brain	Tear	1	Major	25
Brain	Toxic Reaction	1	Major	25
C-01	Hemorrhage	1	Fatal	20
C-02	Fracture	1	Fatal	25
C-04	Dislocation	1	Fatal	25
C-04	Fracture/Disloc	1	Fatal	25
C-05	Fracture	1	Fatal	25
C-06	Fracture/Disloc	1	Fatal	25
Clavicle	Fracture	1	Fatal	3
Clavicle	Fracture/Multi	1	Fatal	6
Elbow	Dislocation	1	Fatal	6
Femur	Fracture	2	Fatal	16
Femur	Fracture	1	Major	16
Great Vessels	Transection	1	Fatal	25
Head	Concussion	2	Major	20
Head	Decapitation	1	Fatal	25
Head	Fracture	3	Fatal	20
Head	Laceration	1	Fatal	25
Humerus	Fracture	4	Fatal	6
Humerus	Fracture	4	Major	6
Jaw	Fracture	1	Minor	6
Jaw	Fracture	1	Minimal	6
Knee	Dislocation	1	Fatal	9
Knee	Dislocation	1	Major	9
Knee	Sprain/Strain	3	Major	9
Knee	Sprain/Strain	1	Minor	9
L-01	Fracture	1	Major	15
L-02	Fracture	1	Major	15
L-04	Fracture	1	Fatal	20
Leg Lower	Amputation	1	Fatal	25
Leg Lower	Fracture	1	Fatal	16
Leg Upper	Fracture	2	Fatal	16
Leg Upper	Fracture	1	Major	16
Leg Upper	Sprain/Strain	1	Minimal	6
Lung	Contusion	1	Fatal	6
Neck	Avulsion (?)	1	Fatal	25
Neck	Fracture	1	Fatal	25
Neck	Sprain/Strain	1	Major	6
Neck	Sprain/Strain	2	Minimal	6
Pubis	Dislocation	1	Fatal	16
Radius Ulna	Fracture	1	Fatal	6
Ribs	Fracture	2	Fatal	6
Shoulder	Dislocation	6	Major	6
Shoulder	Fracture	1	Fatal	9
Shoulder	Fracture	2	Major	9
Shoulder	Sprain/Strain	3	Minimal	3
Skull	Fracture	1	Fatal	20

4. EMERGENCY - CONT'D

Anatomical Part	Injury Type	Number of Injuries	Injury Category	Rating
Skull Basal	Fracture	1	Fatal	20
Spinal Cord	Contusion	1	Fatal	20
T-07	Fracture	1	Fatal	20
T-07	Fracture	1	Major	15
T-11	Fracture	1	Major	15
Thigh	Amputation	1	Fatal	25
Thigh	Fracture	2	Fatal	16
Thorax	Sprain/Strain	1	Minor	6
Tibia Fibula	Fracture	1	Fatal	16
Tibia Fibula	Fracture	1	Major	16
Ulna	Dislocation	1	Major	4
Ulna	Fracture	2	Fatal	6
Ulna	Fracture	3	Major	6
Ulna	Fracture Disloc	1	Major	6
Unknown	Fracture	1	Fatal	4
Wrist	Fracture	1	Major	6

5. MAN-SEAT SEPARATION

Anatomical Part	Injury Type	Number of Injuries	Injury Category	Rating
Brain	Contusion	1	Fatal	20
Brain	Contusion	1	Major	20
C-01	Laceration	1	Fatal	25
C-03	Transection	1	Fatal	25
C-06	Transection	1	Fatal	25
C-06,7	Fracture	1	Major	25
C-07	Fracture	1	Fatal	25
Eye	Laceration	1	Fatal	9
Fibula	Fracture	1	Fatal	3
Great Vessels	Laceration	1	Fatal	25
Head	Concussion	1	Major	20
Head	Fracture	1	Fatal	20
Humerus	Fracture	1	Major	6
Ribs	Fracture	1	Major	6
Sacroiliac	Fracture	1	Fatal	16
Shoulder	Avulsion (?)	1	Major	16
Skull	Fracture	1	Fatal	20
Skull Basal	Fracture	1	Fatal	20
Skull Basal	Fracture	1	Major	20
T-01	Fracture	1	Major	25
Thorax	Multiple Inj	1	Fatal	25
Tibia Fibula	Fracture	1	Major	16

6. PARACHUTE DEPLOYMENT

Anatomical Part	Injury Type	Number of Injuries	Injury Category	Rating
Arm Lower	Fracture	1	Major	6
Back	Sprain/Strain	1	Minor	6
Back	Sprain/Strain	2	Minimal	6
Brain	Hemorrhage	1	Fatal	25
C-02	Transection	1	Fatal	25
C-03	Fracture	1	Fatal	25
C-04	Fracture	1	Fatal	25
C-06	Fracture	1	Fatal	25
Femur	Fracture	1	Fatal	16
Head	Fracture	1	Fatal	20
Head	Sprain/Strain	1	Minor	6
Hip	Amputation	1	Fatal	25
Leg Lower	Amputation	1	Fatal	25
Neck	Aphyxia	1	Fatal	25
Neck	Sprain/Strain	1	Major	6
Neck	Sprain/Strain	2	Minor	6
Neck	Sprain/Strain	1	Minimal	6
Ribs	Fracture	1	Fatal	6
Ribs	Fracture/Multi	1	Fatal	6

6. PARACHUTE DEPLOYMENT - CONT'D

Anatomical Part	Injury Type	Number of Injuries	Injury Category	Rating
Scapula	Sprain/Strain	1	Minimal	3
Shoulder	Sprain/Strain	1	Major	3
Shoulder	Sprain/Strain	1	Minimal	3
Spinal Cord	Contusion	1	Major	20
Spinal Cord	Transection	1	Fatal	25
T-01	Laceration	1	Fatal	20
T-12	Fracture	1	Major	15
Thorax	Sprain/Strain	1	Minor	6

7. DESCENT

Anatomical Part	Injury Type	Number of Injuries	Injury Category	Rating
Face	Burn 2nd Degree	1	Major	4
Hand	Burn 2nd Degree	1	Major	4
Neck	Burn 2nd Degree	1	Major	4
T-03	Fracture	1	Major	15

8. GROUND ENCOUNTER

Anatomical Part	Injury Type	Number of Injuries	Injury Category	Rating
Abdomen	Hemorrhag/Shock	1	Fatal	25
Abdomen	Multiple Inj	4	Fatal	25
Abdomen	Rupture	1	Fatal	25
Ankle	Fracture	3	Fatal	12
Ankle	Fracture	4	Major	12
Ankle	Sprain/Strain	1	Major	4
Ankle	Sprain/Strain	3	Minor	4
Ankle	Sprain/Strain	6	Minimal	4
Arm Lower	Amputation	5	Fatal	25
Arm Lower	Burn 3rd Degree	1	Fatal	4
Arm Lower	Fracture	2	Fatal	6
Arm Upper	Amputation	10	Fatal	25
Arm Upper	Fracture	3	Fatal	6
Arm Upper	Sprain/Strain	1	Minimal	3
Beck	Sprain/Strain	6	Minor	6
Beck	Sprain/Strain	5	Minimal	6
Body	Burn 4th Degree	4	Fatal	25
Body	Dehydration	1	Minor	12
Body	Frostbite	1	Fatal	6
Body	Heatstroke	1	Major	20
Body	Hemorrhag/Shock	1	Fatal	25
Body	Hemorrhag/Shock	1	Major	25
Body	Hypothermia	2	Fatal	9
Body	Hypothermia	4	Major	9
Body	Hypothermia	3	Minor	9
Body	Hypothermia	1	Minimal	9
Body	Multiple Inj	1	Fatal	25
Body	Starvation	1	Minor	12
Body (Fatal)	Disruption	3	Fatal	25
Body	Fragmentation	1	Fatal	25
Body	Multiple Inj	67	Fatal	25
Body 50%	Burn 4th Degree	2	Fatal	25
Body 80%	Burn 4th Degree	2	Fatal	25
Body 90%	Burn 4th Degree	1	Fatal	25
Body Multiple	Burn 1st Degree	1	Fatal	4
Body Multiple	Fracture	5	Fatal	16
Body Multiple	Hemorrhage	1	Fatal	25
Body Multiple	Laceration	2	Fatal	16
Brain	Amnesia	1	Minor	10
Brain	Aphyxia	1	Fatal	25
Brain	Aphyxia Toxic	1	Fatal	25
Brain	Avulsion	4	Fatal	25
Brain	Contusion	2	Fatal	20
Brain	Crush Injury	1	Fatal	25

8. GROUND ENCOUNTER - CONT'D

Anatomical Part	Injury Type	Number of Injuries	Injury Category	Rating
Brain	Exsanguination	1	Fatal	25
Brain	Hematoma	1	Fatal	25
Brain	Laceration	1	Fatal	25
Brain	Transection	1	Fatal	25
C-01	Burn 3rd Degree	1	Fatal	4
C-01	Dislocation	1	Fatal	25
C-01	Fracture	4	Fatal	25
C-01	Sprain/Strain	2	Minimal	6
C-01	Transection	4	Fatal	25
C-02	Fracture	2	Fatal	25
C-02	Fracture	1	Major	25
C-02	Transection	2	Fatal	25
C-05	Dislocation	1	Fatal	25
C-05	Fracture	2	Fatal	25
C-06	Dislocation	1	Fatal	25
C-06	Fracture	1	Fatal	25
C-06	Fracture	2	Fatal	15
C-07	Fracture	1	Fatal	25
C-07	Fracture/Avulsn	1	Fatal	25
C-07	Sprain/Strain	1	Minimal	6
Clavicle	Fracture	6	Fatal	3
Face	Aphyxia	1	Major	25
Face	Fracture	1	Fatal	12
Face	Fracture	4	Fatal	6
Femur	Amputation	1	Fatal	25
Femur	Fracture	2	Fatal	25
Femur	Fracture	2	Fatal	16
Femur	Fracture	1	Major	16
Fibula	Fracture	3	Fatal	3
Fibula	Fracture	2	Major	3
Finger	Avulsion	1	Minor	6
Finger	Fracture	2	Fatal	3
Finger	Fracture	1	Minor	3
Foot	Amputation	1	Fatal	16
Foot	Fracture	3	Fatal	12
Foot	Sprain/Strain	1	Minor	4
Great Vessels	Laceration	2	Fatal	25
Great Vessels	Transection	4	Fatal	25
Hand	Burn 3rd Degree	1	Fatal	4
Hand	Fracture	4	Fatal	3
Head	Avulsion	2	Fatal	25
Head	Concussion	2	Major	20
Head	Concussion	1	Minor	20
Head	Decapitation	19	Fatal	25
Head	Evisceration	1	Fatal	25
Head	Fracture	15	Fatal	20
Head	Multiple Inj	2	Fatal	25
Heart	Laceration	11	Fatal	25
Heart	Rupture	2	Fatal	25
Heart	Transection	1	Fatal	25
Humerus	Amputation	2	Fatal	25
Humerus	Fracture	5	Fatal	6
Humerus	Fracture	1	Major	6
Jaw	Fracture	3	Fatal	6
Kidney	Contusion	2	Major	6
Kidney	Hemorrhage	1	Fatal	16
Knee	Dislocation	1	Fatal	9
Knee	Hemarthrosis	1	Major	4
Knee	Sprain/Strain	4	Major	9
Knee	Sprain/Strain	2	Minor	9
Knee	Sprain/Strain	4	Minimal	9
Knee	Tear	2	Major	6
L-01	Fracture	1	Fatal	20
L-01	Fracture	7	Major	15
L-01	Fracture Disloc	1	Fatal	20
L-01	Transection	1	Fatal	25
L-01	Unknown	1	Major	4
L-01,5	Fracture	1	Fatal	20

8. GROUND ENCOUNTER - CONT'D

Anatomical Part	Injury Type	Number of Injuries	Injury Category	Rating
L-02	Fracture	1	Fatal	20
L-02	Fracture	1	Fatal	15
L-02	Fracture	1	Major	15
L-02	Sprain/Strain	1	Minimal	6
L-03	Fracture	2	Fatal	20
L-03	Fracture	2	Major	20
L-03	Transection	2	Fatal	25
L-05	Fracture	1	Fatal	20
L-05	Sprain/Strain	1	Minimal	6
Leg Lower	Amputation	6	Fatal	25
Leg Lower	Fracture	5	Fatal	16
Leg Lower	Fracture	1	Major	16
Leg Lower	Multiple Inj	1	Fatal	16
Leg Upper	Amputation	6	Fatal	25
Leg Upper	Dislocation	1	Fatal	16
Leg Upper	Fracture	5	Fatal	16
Leg Upper	Fracture	1	Major	16
Leg Upper	Multiple Inj	1	Fatal	16
Liver	Laceration	3	Fatal	25
Lung	Contusion	1	Minor	6
Lung	Laceration	4	Fatal	25
Lung	Pneumothorax	1	Major	16
Lungs	Asphyxia Toxic	1	Fatal	25
Lungs	Drowning	10	Fatal	25
Lungs	Multiple Inj	1	Fatal	25
Lungs	Rupture	1	Fatal	25
Neck	Fracture	6	Fatal	25
Neck	Laceration	1	Fatal	25
Neck	Sprain/Strain	1	Minor	6
Neck	Sprain/Strain	6	Minimal	6
Pelvis	Fracture	11	Fatal	16
Pelvis	Fracture	1	Major	16
Pubis	Dislocation	1	Fatal	16
Pubis	Fracture	5	Fatal	16
Radius	Fracture	5	Fatal	6
Radius Ulna	Fracture	6	Fatal	6
Ribs	Dislocation	1	Major	6
Ribs	Dislocation	1	Major	4
Ribs	Fracture	34	Fatal	6
Ribs	Fracture	1	Minor	6
Sacroiliac	Fracture	1	Fatal	16
Sacroiliac	Fracture	1	Major	16
Sacrum	Fracture	1	Major	16
Sacrum	Sprain/Strain	1	Minimal	6
Scapula	Fracture	1	Fatal	9
Shoulder	Dislocation	1	Fatal	6
Shoulder	Fracture	3	Fatal	9
Shoulder	Sprain/Strain	1	Minor	3
Shoulder	Sprain/Strain	1	Minimal	3
Skull	Fracture	19	Fatal	20
Skull Basal	Dislocation	1	Fatal	25
Skull Basal	Fracture	8	Fatal	20
Spinal Cord	Transection	1	Fatal	25
Spine	Fracture	2	Fatal	25
Spleen	Laceration	1	Fatal	25
Sternum	Fracture	2	Fatal	6
T-01	Fracture	1	Fatal	25
T-01	Fracture	1	Major	25
T-02	Dislocation	2	Fatal	20
T-02	Fracture	1	Major	25
T-02	Fracture	1	Major	15
T-02	Transection	1	Fatal	25
T-02,3,11 & 12	Fracture	1	Fatal	25
T-03	Dislocation	2	Fatal	20
T-03	Fracture	1	Major	25
T-03	Fracture	3	Major	15
T-03	Fracture Disloc	1	Fatal	25
T-03	Hematoma	1	Major	16

8. GROUND ENCOUNTER - CONT'D

Anatomical Part	Injury Type	Number of Injuries	Injury Category	Rating
T-03	Transection	1	Fatal	25
T-04	Avulsion	1	Fatal	25
T-04	Fracture	1	Major	25
T-04	Fracture	4	Major	15
T-04	Fracture Dialoc	1	Fatal	25
T-04	Hematoma	1	Major	16
T-04	Transection	1	Fatal	25
T-04 Cord Inj	Fracture/Contus	1	Fatal	25
T-04 Cord Inj	Fracture/Contus	1	Major	25
T-05	Fracture	1	Fatal	20
T-05	Fracture	1	Fatal	15
T-05	Fracture	6	Major	15
T-06	Fracture	1	Fatal	15
T-06	Fracture	7	Major	15
T-06 Cord Inj	Fracture/Contus	1	Fatal	25
T-07	Fracture	1	Major	20
T-07	Fracture	3	Major	15
T-08	Fracture	2	Major	15
T-08	Sprain/Strain	1	Minimal	6
T-08	Transection	1	Fatal	25
T-08,9	Fracture	1	Fatal	16
T-09	Fracture	1	Fatal	20
T-09	Fracture	4	Major	15
T-09	Fracture Dialoc	1	Fatal	20
T-10	Dislocation	1	Fatal	20
T-10	Fracture	1	Fatal	20
T-10	Fracture	1	Major	15
T-11	Dislocation	1	Fatal	20
T-12	Fracture	1	Fatal	15
T-12	Fracture	3	Major	15
T-12	Fracture Dialoc	1	Fatal	20
T-12	Transection	1	Fatal	25
Thorax	Asphyxia	1	Fatal	25
Thorax	Crush Injury	1	Fatal	25
Thorax	Evisceration	1	Fatal	25
Thorax	Fracture	4	Fatal	20
Thorax	Multiple Inj	3	Fatal	25
Thorax	Rupture	1	Fatal	25
Thorax	Sprain/Strain	1	Minimal	6
Thorax	Transection	1	Fatal	25
Thumb	Amputation	1	Fatal	8
Tibia	Fracture	4	Fatal	16
Tibia	Fracture	1	Major	16
Tibia Fibula	Fracture	12	Fatal	16
Ulna	Fracture	1	Fatal	6
Wrist	Fracture	1	Fatal	6
Wrist	Fracture	1	Major	6

9. UNKNOWN

Anatomical Part	Injury Type	Number of Injuries	Injury Category	Rating
Abdomen	Hematoma	1	Fatal	6
Arm Lower	Fracture	1	Fatal	6
Arm Upper	Fracture	1	Fatal	6
Arm Upper	Fracture	1	Major	6
Back	Sprain/Strain	2	Minor	6
Body	Hemorrhag/Shock	1	Major	25
Body (Fatal)	Unknown	1	Fatal	25
Body Multiple	Unknown	3	Fatal	25
Brain	Amnesia	1	Minor	10
C-01	Dislocation	1	Fatal	25
Hand	Amputation	1	Fatal	16
Head	Fracture	1	Fatal	20
L-02	Fracture	1	Major	15
Leg Lower	Fracture	1	Fatal	16
Liver	Laceration	1	Fatal	25

9. UNKNOWN - CONT'D

Anatomical Part	Injury Type	Number of Injuries	Injury Category	Rating
Neck	Burn 2nd Degree	1	Minimal	4
Neck	Sprain/Strain	1	Minor	6
Neck	Sprain/Strain	1	Minimal	6
Never Recovered	Unknown	5	Fatal	25
Ribs	Fracture	1	Fatal	6
Ribs	Fracture	1	Major	6
Sacroiliac	Sprain/Strain	1	Minimal	6
Spinal Cord	Contusion	1	Fatal	20
T-06	Fracture	1	Fatal	20
Thumb	Avulsion	1	Minor	6
Unknown	Multiple Inj	1	Fatal	4
Unknown (Fatal)	Unknown	1	Fatal	25

TABLE B-2 - SERIOUS INJURY TABULATION EXCLUDING 126 FATALITIES

1. INITIATION PHASE

Anatomical Part	Injury Type	Number of Injuries	Injury Category	Rating
Face	Burn 2nd Degree	1	Major	4
Face	Burn 2nd Degree	1	Minor	4
Foot	Sprain/Strain	1	Minor	4
Neck	Burn 2nd Degree	1	Major	4
Neck	Burn 2nd Degree	1	Minor	4

2. PATH CLEARANCE - No serious injuries were reported

3. EJECTION

Anatomical Part	Injury Type	Number of Injuries	Injury Category	Rating
Arm Lower	Fracture	1	Major	6
Arm Lower	Sprain/Strain	1	Major	3
Back	Sprain/Strain	8	Minor	6
Back	Sprain/Strain	13	Minimal	6
Brain	Unknown	1	Minor	12
C-01	Fracture	1	Minor	15
C-01	Sprain/Strain	1	Major	6
C-01	Sprain/Strain	4	Minor	6
C-01	Sprain/Strain	4	Minimal	6
C-02	Sprain/Strain	1	Minor	6
C-03	Fracture	1	Major	15
C-04,5,6	Fracture	1	Major	15
C-05	Fracture	1	Major	15
Eye	Unknown	1	Major	4
Finger	Avulsion	2	Minimal	6
Finger	Fracture	1	Major	3
Foot	Contusion	1	Major	4
Foot	Contusion	5	Minimal	4
Head	Contusion	1	Minor	20
Head	Unknown	1	Major	4
Humerus	Fracture	1	Major	6
Jaw	Sprain/Strain	1	Major	3
Knee	Sprain/Strain	1	Minor	9
L-01	Fracture	11	Major	15
L-01	Sprain/Strain	1	Minor	6
L-01	Sprain/Strain	2	Minimal	6
L-02	Fracture	2	Major	15
L-02	Fracture	1	Minimal	15
L-02	Sprain/Strain	1	Minimal	6
L-02,4	Fracture	1	Major	15
L-04	Sprain/Strain	1	Minimal	6
L-05	Sprain/Strain	1	Minimal	6
Leg Lower	Fracture	1	Major	16
Leg Lower	Sprain/Strain	1	Minimal	4
Neck	Fracture	1	Major	15
Neck	Sprain/Strain	4	Major	6
Neck	Sprain/Strain	1	Minor	6
Neck	Sprain/Strain	31	Minimal	6
Ribs	Fracture	1	Major	6
Sacroiliac	Sprain/Strain	1	Minimal	6
Scapula	Dislocation	1	Major	6
Shoulder	Fracture/Dialoc	1	Major	6
Shoulder	Sprain/Strain	3	Minimal	3
Sternum	Fracture	1	Major	6
T-01	Fracture	1	Major	15
T-02	Stretching	1	Major	14
T-03	Fracture	1	Major	15
T-03,4,5,6	Sprain/Strain	1	Minimal	6
T-04	Fracture	2	Major	15
T-04,5	Fracture	1	Major	15
T-05	Fracture	4	Major	15
T-05 Cord Inj	Fracture/Contus	1	Major	25

3. EJECTION - CONT'D

Anatomical Part	Injury Type	Number of Injuries	Injury Category	Rating
T-06	Fracture	3	Major	15
T-06	Sprain/Strain	2	Minimal	6
T-07	Fracture	5	Major	15
T-07	Sprain/Strain	1	Minimal	6
T-07,9,10	Fracture	1	Major	15
T-08	Fracture	7	Major	15
T-09	Fracture	4	Major	15
T-10	Fracture	5	Major	15
T-11	Fracture	10	Major	15
T-11,12	Fracture	1	Major	15
T-12	Fracture	7	Major	15
T-12	Fracture	1	Minimal	15
Thorax	Sprain/Strain	1	Minimal	6
Ulna	Fracture	1	Major	6

4. EMERGENCY

Anatomical Part	Injury Type	Number of Injuries	Injury Category	Rating
Arm Upper	Fracture	1	Major	6
Arm Upper	Sprain/Strain	1	Minimal	3
Back	Sprain/Strain	2	Minimal	6
Brain	Tear	1	Major	25
Brain	Toxic Reaction	1	Major	25
Femur	Fracture	1	Major	16
Head	Concussion	2	Major	20
Humerus	Fracture	4	Major	6
Jaw	Fracture	1	Minor	6
Jaw	Fracture	1	Minimal	6
Knee	Dislocation	1	Major	9
Knee	Sprain/Strain	3	Major	9
Knee	Sprain/Strain	1	Minor	9
L-01	Fracture	1	Major	15
L-02	Fracture	1	Major	15
Leg Upper	Fracture	1	Major	16
Leg Upper	Sprain/Strain	1	Minimal	6
Neck	Sprain/Strain	1	Major	6
Neck	Sprain/Strain	2	Minimal	6
Shoulder	Dislocation	6	Major	6
Shoulder	Fracture	2	Major	9
Shoulder	Sprain/Strain	3	Minimal	3
T-07	Fracture	1	Major	15
T-11	Fracture	1	Major	15
Thorax	Sprain/Strain	1	Minor	6
Tibia Fibula	Fracture	1	Major	16
Ulna	Dislocation	1	Major	4
Ulna	Fracture	3	Major	6
Ulna	Fracture Dialoc	1	Major	6
Wrist	Fracture	1	Major	6

5. MAN-SEAT SEPARATION

Anatomical Part	Injury Type	Number of Injuries	Injury Category	Rating
Brain	Concussion	1	Major	20
C-06,7	Fracture	1	Major	25
Head	Concussion	14	Major	20
Humerus	Fracture	1	Major	6
Ribs	Fracture	1	Major	6
Shoulder	Avulsion (?)	1	Major	16
Skull Basal	Fracture	1	Major	20
T-01	Fracture	1	Major	25
Tibia Fibula	Fracture	1	Major	16

6. PARACHUTE DEPLOYMENT

Anatomical Part	Injury Type	Number of Injuries	Injury Category	Rating
Arm Lower	Fracture	1	Major	6
Back	Sprain/Strain	1	Minor	6
Back	Sprain/Strain	2	Minimal	6
Hip	Sprain/Strain	1	Minor	6
Neck	Sprain/Strain	1	Major	6
Neck	Sprain/Strain	2	Minor	6
Neck	Sprain/Strain	1	Minimal	6
Scapula	Sprain/Strain	1	Minimal	3
Shoulder	Sprain/Strain	1	Major	3
Shoulder	Sprain/Strain	1	Minimal	3
Spinal Cord	Contusion	1	Major	20
T-12	Fracture	1	Major	15
Thorax	Sprain/Strain	1	Minor	6

7. DESCENT

Anatomical Part	Injury Type	Number of Injuries	Injury Category	Rating
Face	Burn 2nd Degree	1	Major	4
Hand	Burn 2nd Degree	1	Major	4
Neck	Burn 2nd Degree	1	Major	4
T-03	Fracture	1	Major	15

8. GROUND ENCOUNTER

Anatomical Part	Injury Type	Number of Injuries	Injury Category	Rating
Ankle	Fracture	4	Major	12
Ankle	Sprain/Strain	1	Major	4
Ankle	Sprain/Strain	3	Minor	4
Ankle	Sprain/Strain	6	Minimal	4
Arm Upper	Sprain/Strain	1	Minimal	3
Back	Sprain/Strain	6	Minor	6
Back	Sprain/Strain	5	Minimal	6
Body	Dehydration	1	Minor	12
Body	Heatstroke	1	Major	20
Body	Hemorrhag/Shock	1	Major	25
Body	Hypothermia	4	Major	9
Body	Hypothermia	3	Minor	9
Body	Hypothermia	1	Minimal	9
Body	Starvation	1	Minor	12
Brain	Amnesia	1	Minor	10
C-01	Sprain/Strain	2	Minimal	6
C-02	Fracture	1	Major	25
C-07	Sprain/Strain	1	Minimal	6
Face	Asphyxia	1	Major	25
Femur	Fracture	1	Major	16
Fibula	Fracture	2	Major	3
Finger	Avulsion	1	Minor	6
Finger	Fracture	1	Minor	3
Foot	Sprain/Strain	1	Minor	4
Head	Concussion	2	Major	20
Head	Concussion	1	Minor	20
Humerus	Fracture	1	Major	6
Kidney	Contusion	2	Major	6
Knee	Hemarthrosis	1	Major	4
Knee	Sprain/Strain	4	Major	9
Knee	Sprain/Strain	2	Minor	9
Knee	Sprain/Strain	4	Minimal	9
Knee	Tear	2	Major	6
L-01	Fracture	7	Major	15
L-01	Unknown	1	Major	4
L-02	Fracture	1	Major	15
L-02	Sprain/Strain	1	Minimal	6
L-03	Fracture	2	Major	20
L-05	Sprain/Strain	1	Minimal	6

8. GROUND ENCOUNTER - CONT'D

Anatomical Part	Injury Type	Number of Injuries	Injury Category	Rating
Leg Lower	Fracture	1	Major	16
Leg Upper	Fracture	1	Major	16
Lung	Contusion	1	Minor	6
Lung	Pneumothorax	1	Major	16
Neck	Sprain/Strain	1	Minor	6
Neck	Sprain/Strain	6	Minimal	6
Pelvis	Fracture	1	Major	16
Ribs	Dislocation	1	Major	6
Ribs	Dislocation	1	Major	4
Ribs	Fracture	1	Minor	6
Ribs	Fracture	1	Major	16
Sacroiliac	Fracture	1	Major	16
Sacrum	Fracture	1	Major	16
Sacrum	Sprain/Strain	1	Minimal	6
Shoulder	Sprain/Strain	1	Minor	3
Shoulder	Sprain/Strain	1	Minimal	3
T-01	Fracture	1	Major	25
T-02	Fracture	1	Major	25
T-02	Fracture	1	Major	15
T-03	Fracture	1	Major	25
T-03	Fracture	3	Major	15
T-03	Hematoma	1	Major	16
T-03	Hematoma	1	Major	25
T-04	Fracture	1	Major	25
T-04	Fracture	4	Major	15
T-04	Hematoma	1	Major	16
T-04	Hematoma	1	Major	25
T-04	Cord Inj	1	Major	25
T-05	Fracture	6	Major	15
T-06	Fracture	7	Major	15
T-07	Fracture	1	Major	20
T-07	Fracture	3	Major	15
T-08	Fracture	2	Major	15
T-08	Fracture	1	Major	15
T-08	Sprain/Strain	12	Minimal	6
T-09	Fracture	4	Major	15
T-10	Fracture	1	Major	15
T-12	Fracture	3	Major	15
Thorax	Sprain/Strain	1	Minimal	6
Tibia	Fracture	1	Major	16
Wrist	Fracture	1	Major	6

9. UNKNOWN

Anatomical Part	Injury Type	Number of Injuries	Injury Category	Rating
Arm Upper	Fracture	1	Major	6
Back	Sprain/Strain	2	Minor	6
Body	Hemorrhag/Shock	1	Major	25
Brain	Amnesia	1	Minor	10
L-02	Fracture	1	Major	15
Neck	Burn 2nd Degree	1	Minimal	4
Neck	Sprain/Strain	1	Minor	6
Neck	Sprain/Strain	1	Minimal	6
Ribs	Fracture	1	Major	6
Sacroiliac	Sprain/Strain	1	Minimal	6
Thumb	Avulsion	1	Minor	6

The following is a similar tabulation of the more serious injuries that occurred during each of the 8 phases of escape, and an unknown category, produced using the above selection criterion. In this case, assessed AIS ranges are used instead of the subjective operational ratings used in Tables B-1 and B-2.

With regard to the AIS Range, a 00 notation has been used when there is no listing for the referenced injury type in connection with the indicated anatomical part. Where there are multiple listings, a slash (/) has been used to separate both the injury types and the AIS range with the appropriate rating being indicated respectively, i.e., Strain/Sprain 1/00

TABLE B-3 - SERIOUS INJURY TABULATION

1. INITIATION PHASE					3. EJECTION - CONT'D				
Anatomical Part	Injury Type	Number of Injuries	Injury Category	AIS Range	Anatomical Part	Injury Type	Number of Injuries	Injury Category	AIS Range
Body	Multiple Inj	1	Fatal	9	Head	Concussion	1	Minor	2
Body Multiple	Burn 1st Degree	1	Fatal	2	Head	Fracture	1	Fatal	2
Clavicle	Fracture	1	Fatal	2	Head	Unknown	2	Fatal	9
Face	Burn 2nd Degree	2	Fatal	1	Head	Unknown	1	Major	9
Face	Burn 2nd Degree	1	Major	1	Humerus	Fracture	1	Fatal	2-3
Face	Burn 2nd Degree	1	Minor	1	Humerus	Fracture	1	Major	2-3
Foot	Sprain/Strain	1	Minor	1/00	Jaw	Fracture	1	Fatal	1-2
Hand	Burn 3rd Degree	1	Fatal	2	Jaw	Sprain/Strain	1	Major	N/A
Liver	Laceration	1	Fatal	2-5	Knee	Sprain/Strain	1	Minor	2/00
Neck	Burn 2nd Degree	1	Fatal	1	L-01	Dislocation	1	Fatal	2-3
Neck	Burn 2nd Degree	1	Major	1	L-01	Fracture	2	Fatal	2-3
Neck	Burn 2nd Degree	1	Minor	1	L-01	Fracture	11	Major	2-3
Neck	Burn 3rd Degree	1	Fatal	2	L-01	Sprain/Strain	1	Minor	00/1
Ribs	Fracture	1	Fatal	2-5	L-01	Sprain/Strain	2	Minimal	00/1
Skull	Fracture	1	Fatal	2-4	L-02	Fracture	2	Major	2-3
Skull Basal	Fracture	1	Fatal	3-4	L-02	Fracture	1	Minimal	2-3
Sternum	Fracture	1	Fatal	2	L-02	Sprain/Strain	1	Minimal	00/1
Tibia Fibula	Fracture	1	Fatal	2-3	L-02,4	Fracture	1	Major	2-3
					L-04	Sprain/Strain	1	Minimal	00/1
					L-05	Sprain/Strain	1	Minimal	00/1
					Leg Lower	Fracture	1	Fatal	2-3
					Leg Lower	Fracture	1	Major	2-3
					Leg Lower	Sprain/Strain	1	Minimal	1-2
					Neck	Fracture	1	Major	2-3
					Neck	Sprain/Strain	4	Major	00/1
					Neck	Sprain/Strain	1	Minor	00/1
					Neck	Sprain/Strain	31	Minimal	00/1
					Ribs	Fracture	1	Fatal	2-5
					Ribs	Fracture	1	Major	2-5
					Sacroiliac	Sprain/Strain	1	Minimal	00/00
					Scapula	Dislocation	1	Major	00
					Shoulder	Fracture/Disloc	1	Major	00/2
					Shoulder	Sprain/Strain	3	Minimal	1/00
					Skull	Fracture	1	Fatal	2-4
					Spinal Cord	Contusion	1	Fatal	3
					Sternum	Fracture	1	Major	2
					T-01	Fracture	1	Major	2-3
					T-02	Stretching	1	Major	00
					T-03	Fracture	1	Major	2-3
					T-03,4,5,6	Sprain/Strain	1	Minimal	00/1
					T-04	Fracture	2	Major	2-3
					T-04,5	Fracture	1	Major	2-3
					T-05	Fracture	2	Fatal	2-3
					T-05	Fracture	4	Major	2-3
					T-05 Cord Inj	Fracture/Contus	1	Major	3
					T-06	Fracture	2	Fatal	2-3
					T-06	Fracture	3	Major	2-3
					T-06	Sprain/Strain	2	Minimal	00/1
					T-07	Fracture	5	Major	2-3
					T-07	Sprain/Strain	1	Minimal	00/1
					T-07,9,10	Fracture	1	Major	2-3

3. EJECTION - CONT'D

Anatomical Part	Injury Type	Number of Injuries	Injury Category	AIS Range
T-08	Dislocation	1	Fatal	2-3
T-08	Fracture	7	Major	2-3
T-09	Fracture	1	Fatal	2-3
T-09	Fracture	4	Major	2-3
T-10	Fracture	1	Fatal	2-3
T-10	Fracture	5	Major	2-3
T-11	Fracture	10	Major	2-3
T-11,12	Fracture	1	Major	2-3
T-12	Fracture	1	Fatal	2-3
T-12	Fracture	7	Major	2-3
T-12	Fracture	1	Minimal	2-3
Thorax	Sprain/Strain	1	Minimal	00/00
Tibia Fibula	Fracture	1	Fatal	2-3
Ulna	Fracture	1	Major	2-3

4. EMERGENCE

Anatomical Part	Injury Type	Number of Injuries	Injury Category	AIS Range
Abdomen	Evisceration	1	Fatal	9
Abdomen	Laceration	1	Fatal	9
Arm Upper	Amputation	2	Fatal	3
Arm Upper	Fracture	1	Fatal	2-3
Arm Upper	Fracture	1	Major	2-3
Arm Upper	Sprain/Strain	1	Minimal	1/00
Back	Sprain/Strain	2	Minimal	00/1
Body (Fatal)	Multiple Inj	1	Fatal	9
Brachial	Fracture	1	Fatal	1-3
Brain	Contusion	1	Fatal	3-5
Brain	Tear	1	Major	4-6
Brain	Toxic Reaction	1	Major	00
C-01	Hemorrhage	1	Fatal	9
C-02	Fracture	1	Fatal	2-3
C-04	Dislocation	1	Fatal	2-3
C-04	Fracture/Disloc	1	Fatal	2-5
C-05	Fracture	1	Fatal	2-3
C-06	Fracture/Disloc	1	Fatal	2-5
Clavicle	Fracture	1	Fatal	2
Clavicle	Fracture/Multi	1	Fatal	2
Elbow	Dislocation	1	Fatal	1
Femur	Fracture	2	Fatal	3
Femur	Fracture	1	Major	3
Great Vessels	Transaction	1	Fatal	2-6
Head	Concussion	2	Major	2
Head	Decapitation	1	Fatal	6
Head	Fracture	3	Fatal	2-4
Head	Laceration	1	Fatal	3-6
Humerus	Fracture	4	Fatal	2-3
Humerus	Fracture	4	Major	2-3
Jaw	Fracture	1	Minor	1-2
Jaw	Fracture	1	Minimal	1-2
Knee	Dislocation	1	Fatal	2
Knee	Dislocation	1	Major	2
Knee	Sprain/Strain	3	Major	2/00
Knee	Sprain/Strain	1	Minor	2/00
L-01	Fracture	1	Major	2-3
L-02	Fracture	1	Major	2-3
L-04	Fracture	1	Fatal	2-3
Leg Lower	Amputation	1	Fatal	3-4
Leg Lower	Fracture	1	Fatal	2-3
Leg Upper	Fracture	2	Fatal	2-3
Leg Upper	Fracture	1	Major	2-3
Leg Upper	Sprain/Strain	1	Minimal	1/00
Lung	Contusion	1	Fatal	3-4
Neck	Avulsion (?)	1	Fatal	1-3
Neck	Fracture	1	Fatal	2-3
Neck	Sprain/Strain	1	Major	00/1
Neck	Sprain/Strain	2	Minimal	00/1
Pubis	Dislocation	1	Fatal	2-3

4. EMERGENCE - CONT'D

Anatomical Part	Injury Type	Number of Injuries	Injury Category	AIS Range
Radius Ulna	Fracture	1	Fatal	2-3
Ribs	Fracture	2	Fatal	2-5
Shoulder	Dislocation	6	Major	2
Shoulder	Fracture	1	Fatal	00
Shoulder	Fracture	2	Major	00
Shoulder	Sprain/Strain	3	Minimal	1/00
Skull	Fracture	1	Fatal	2-4
Skull Basal	Fracture	1	Fatal	3-4
Spinal Cord	Contusion	1	Fatal	3
T-07	Fracture	1	Fatal	2-3
T-07	Fracture	1	Major	2-3
T-11	Fracture	1	Major	2-3
Thigh	Amputation	1	Fatal	4
Thigh	Fracture	2	Fatal	3
Thorax	Sprain/Strain	1	Minor	9
Tibia Fibula	Fracture	1	Fatal	2-3
Tibia Fibula	Fracture	1	Major	2-3
Ulna	Dislocation	1	Major	00
Ulna	Fracture	2	Fatal	2-3
Ulna	Fracture	3	Major	2-3
Ulna	Fracture Disloc	1	Major	2-3
Unknown	Fracture	1	Fatal	9
Wrist	Fracture	1	Major	2-3

5. MAN-SEAT SEPARATION

Anatomical Part	Injury Type	Number of Injuries	Injury Category	AIS Range
Brain	Contusion	1	Fatal	3-5
Brain	Contusion	1	Major	3-5
C-01	Laceration	1	Fatal	6
C-03	Transaction	1	Fatal	5-6
C-06	Transaction	1	Fatal	5
C-06,7	Fracture	1	Major	2-3
C-07	Fracture	1	Fatal	2-3
Eye	Laceration	1	Fatal	1-2
Fibula	Fracture	1	Fatal	2
Great Vessels	Laceration	1	Fatal	2-6
Head	Concussion	1	Major	2
Head	Fracture	1	Fatal	2-4
Humerus	Fracture	1	Major	2-3
Ribs	Fracture	1	Major	2-5
Sacroiliac	Fracture	1	Fatal	3
Shoulder	Avulsion (?)	1	Major	00
Skull	Fracture	1	Fatal	2-4
Skull Basal	Fracture	1	Fatal	3-4
Skull Basal	Fracture	1	Major	3-4
T-01	Fracture	1	Major	2-3
Thorax	Multiple Inj	1	Fatal	9
Tibia Fibula	Fracture	1	Major	2-3

6. PARACHUTE DEPLOYMENT

Anatomical Part	Injury Type	Number of Injuries	Injury Category	AIS Range
Arm Lower	Fracture	1	Major	2-3
Back	Sprain/Strain	1	Minor	00/1
Back	Sprain/Strain	2	Minimal	00/1
Brain	Hemorrhage	1	Fatal	3-5
C-02	Transaction	1	Fatal	5-6
C-03	Fracture	1	Fatal	2-3
C-04	Fracture	1	Fatal	2-3
C-06	Fracture	1	Fatal	2-3
Femur	Fracture	1	Fatal	3
Head	Fracture	1	Fatal	2-4
Hip	Sprain/Strain	1	Minor	1/00
Leg Lower	Amputation	1	Fatal	3
Neck	Asphyxia	1	Fatal	00
Neck	Sprain/Strain	1	Major	00/1

6. PARACHUTE DEPLOYMENT

Anatomical Part	Injury Type	Number of Injuries	Injury Category	AIS Range
Neck	Sprain/Strain	2	Minor	00/1
Neck	Sprain/Strain	1	Minimal	00/1
Ribs	Fracture	1	Fatal	2-5
Ribs	Fracture/Multi	1	Fatal	2-5
Scapula	Sprain/Strain	1	Minimal	00/00
Shoulder	Sprain/Strain	1	Major	1/00
Shoulder	Sprain/Strain	1	Minimal	1/00
Spinal Cord	Contusion	1	Major	3
Spinal Cord	Transaction	1	Fatal	5-6
T-01	Laceration	1	Fatal	5
T-12	Fracture	1	Major	2-3
Thorax	Sprain/Strain	1	Minor	00/00

7. DESCENT

Anatomical Part	Injury Type	Number of Injuries	Injury Category	AIS Range
Face	Burn 2nd Degree	1	Major	1
Hand	Burn 2nd Degree	1	Major	1
Neck	Burn 2nd Degree	1	Major	1
T-03	Fracture	1	Major	2-3

8. GROUND ENCOUNTER

Anatomical Part	Injury Type	Number of Injuries	Injury Category	AIS Range
Abdomen	Hemorrhage/Shock	1	Fatal	9/00
Abdomen	Multiple Inj	4	Fatal	9
Abdomen	Rupture	1	Fatal	3-4
Ankle	Fracture	3	Fatal	2-3
Ankle	Fracture	4	Major	2-3
Ankle	Sprain/Strain	1	Major	1/00
Ankle	Sprain/Strain	3	Minor	1/00
Ankle	Sprain/Strain	6	Minimal	1/00
Arm Lower	Amputation	5	Fatal	3
Arm Lower	Burn 3rd Degree	1	Fatal	2
Arm Lower	Fracture	2	Fatal	2-3
Arm Upper	Amputation	10	Fatal	3
Arm Upper	Fracture	3	Fatal	2-3
Arm Upper	Sprain/Strain	1	Minimal	1/00
Back	Sprain/Strain	6	Minor	00/1
Back	Sprain/Strain	5	Minimal	00/1
Body	Burn 4th Degree	4	Fatal	6
Body	Dehydration	1	Minor	00
Body	Frostbite	1	Fatal	00
Body	Heatstroke	1	Major	00
Body	Hemorrhage/Shock	1	Fatal	9/00
Body	Hemorrhage/Shock	1	Major	9/00
Body	Hypothermia	2	Fatal	1-5
Body	Hypothermia	4	Major	1-5
Body	Hypothermia	3	Minor	1-5
Body	Hypothermia	1	Minimal	1-5
Body	Multiple Inj	1	Fatal	9
Body	Starvation	1	Minor	00
Body (Fatal)	Disruption	3	Fatal	9
Body	Fragmentation	1	Fatal	9
Body	Multiple Inj	67	Fatal	9
Body 50%	Burn 4th Degree	2	Fatal	5
Body 80%	Burn 4th Degree	2	Fatal	5
Body 90%	Burn 4th Degree	1	Fatal	6
Body Multiple	Burn 1st Degree	1	Fatal	9
Body Multiple	Fracture	5	Fatal	9
Body Multiple	Hemorrhage	1	Fatal	9
Body Multiple	Laceration	2	Fatal	9
Brain	Amnesia	1	Minor	2-3
Brain	Asphyxia	1	Fatal	00
Brain	Asphyxia Toxic	1	Fatal	00
Brain	Avulsion	4	Fatal	9
Brain	Contusion	2	Fatal	3-5

8. GROUND ENCOUNTER - CONT'D

Anatomical Part	Injury Type	Number of Injuries	Injury Category	AIS Range
Brain	Crush Injury	1	Fatal	6
Brain	Exsanguination	1	Fatal	00
Brain	Hematoma	1	Fatal	4-5
Brain	Laceration	1	Fatal	4-6
Brain	Transaction	1	Fatal	9
C-01	Burn 3rd Degree	1	Fatal	2
C-01	Dislocation	1	Fatal	2-3
C-01	Fracture	4	Fatal	2-3
C-01	Sprain/Strain	2	Minimal	00/1
C-01	Transaction	4	Fatal	5-6
C-02	Fracture	2	Fatal	2-3
C-02	Fracture	1	Major	2-3
C-02	Transaction	2	Fatal	5-6
C-05	Dislocation	1	Fatal	2-3
C-05	Fracture	2	Fatal	2-3
C-06	Dislocation	1	Fatal	2-3
C-06	Fracture	1	Fatal	2-3
C-06	Fracture	2	Fatal	2-3
C-07	Fracture	1	Fatal	2-3
C-07	Fracture/Avulsion	1	Fatal	2-3
C-07	Sprain/Strain	1	Minimal	00/1
Clavicle	Fracture	6	Fatal	2
Face	Asphyxia	1	Major	00
Face	Fracture	1	Fatal	1-4
Face	Fracture	4	Fatal	1-4
Femur	Amputation	1	Fatal	4
Femur	Fracture	2	Fatal	3
Femur	Fracture	2	Fatal	3
Femur	Fracture	1	Major	3
Fibula	Fracture	3	Fatal	2
Fibula	Fracture	2	Major	2
Finger	Avulsion	1	Minor	1-2
Finger	Fracture	2	Fatal	1
Finger	Fracture	1	Minor	1
Finger	Amputation	1	Fatal	3
Foot	Fracture	3	Fatal	2
Foot	Sprain/Strain	1	Minor	1/00
Great Vessels	Laceration	2	Fatal	2-6
Great Vessels	Transaction	4	Fatal	2-6
Hand	Burn 3rd Degree	1	Fatal	2
Hand	Fracture	4	Fatal	2
Head	Avulsion	2	Fatal	1-3
Head	Concussion	2	Major	2
Head	Concussion	1	Minor	2
Head	Decapitation	19	Fatal	6
Head	Evisceration	1	Fatal	9
Head	Fracture	15	Fatal	2-4
Head	Multiple Inj	2	Fatal	9
Heart	Laceration	11	Fatal	3-6
Heart	Rupture	2	Fatal	5-6
Heart	Transaction	1	Fatal	9
Humerus	Amputation	2	Fatal	3
Humerus	Fracture	5	Fatal	2-3
Humerus	Fracture	1	Major	2-3
Jaw	Fracture	3	Fatal	1-2
Kidney	Contusion	2	Major	2-3
Kidney	Hemorrhage	1	Fatal	00
Knee	Dislocation	1	Fatal	2
Knee	Hemarthrosis	1	Major	00
Knee	Sprain/Strain	4	Major	2/00
Knee	Sprain/Strain	2	Minor	2/00
Knee	Sprain/Strain	4	Minimal	2/00
Knee	Tear	2	Major	2
L-01	Fracture	1	Fatal	2-3
L-01	Fracture	7	Major	2-3
L-01	Fracture Disloc	1	Fatal	2-3
L-01	Transaction	1	Fatal	5
L-01	Unknown	1	Major	9
L-01,5	Fracture	1	Fatal	2-3

8. GROUND ENCOUNTER - CONT'D

Anatomical Part	Injury Type	Number of Injuries	Injury Category	AIS Range
L-02	Fracture	1	Fatal	2-3
L-02	Fracture	1	Fatal	2-3
L-02	Fracture	1	Major	2-3
L-02	Sprain/Strain	1	Minimal	00/1
L-03	Fracture	2	Fatal	2-3
L-03	Fracture	2	Major	2-3
L-03	Transection	2	Fatal	5
L-05	Fracture	1	Fatal	2-3
L-05	Sprain/Strain	1	Minimal	00/1
Leg Lower	Amputation	6	Fatal	3-4
Leg Lower	Fracture	5	Fatal	2-3
Leg Lower	Fracture	1	Major	2-3
Leg Lower	Multiple Inj	1	Fatal	9
Leg Upper	Amputation	6	Fatal	4
Leg Upper	Dislocation	1	Fatal	2
Leg Upper	Fracture	5	Fatal	3
Leg Upper	Fracture	1	Major	3
Leg Upper	Multiple Inj	1	Fatal	9
Liver	Laceration	3	Fatal	2-5
Lung	Contusion	1	Minor	3-4
Lung	Laceration	4	Fatal	3-5
Lung	Pneumothorax	1	Major	00-5
Lungs	Asphyxia Toxic	1	Fatal	00
Lungs	Drowning	10	Fatal	00
Lungs	Multiple Inj	1	Fatal	9
Lungs	Rupture	1	Fatal	9
Neck	Fracture	6	Fatal	2-3
Neck	Laceration	1	Fatal	1-3
Neck	Sprain/Strain	1	Minor	00/1
Neck	Sprain/Strain	6	Minimal	00/1
Pelvis	Fracture	11	Fatal	2-3
Pelvis	Fracture	1	Major	2-3
Pubis	Dislocation	1	Fatal	2-3
Pubis	Fracture	5	Fatal	2-3
Radius	Fracture	5	Fatal	2-3
Radius Ulna	Fracture	6	Fatal	2-3
Ribs	Dislocation	1	Major	00
Ribs	Dislocation	1	Major	00
Ribs	Fracture	34	Fatal	2-5
Ribs	Fracture	1	Minor	2-5
Sacroiliac	Fracture	1	Fatal	3
Sacroiliac	Fracture	1	Major	3
Sacrum	Fracture	1	Major	2-3
Sacrum	Sprain/Strain	1	Minimal	00/00
Scapula	Fracture	1	Fatal	2
Shoulder	Dislocation	1	Fatal	2
Shoulder	Fracture	3	Fatal	9
Shoulder	Sprain/Strain	1	Minor	1/00
Shoulder	Sprain/Strain	1	Minimal	1/00
Skull	Fracture	19	Fatal	2-4
Skull Basal	Dislocation	1	Fatal	00
Skull Basal	Fracture	8	Fatal	3-4
Spinal Cord	Transection	1	Fatal	5-6
Spine	Fracture	2	Fatal	2-3
Spleen	Laceration	1	Fatal	2-5
Sternum	Fracture	2	Fatal	2
T-01	Fracture	1	Fatal	2-3
T-01	Fracture	1	Major	2-3
T-02	Dislocation	2	Fatal	2-3
T-02	Fracture	1	Major	2-3
T-02	Fracture	1	Major	2-3
T-02	Transection	1	Fatal	5
T-02,3,11 & 12	Fracture	1	Fatal	2-3
T-03	Dislocation	2	Fatal	2-3
T-03	Fracture	1	Major	2-3
T-03	Fracture	3	Major	2-3
T-03	Fracture Dialoc	1	Fatal	2-3
T-03	Hematoma	1	Major	00
T-03	Transection	1	Fatal	5

8. GROUND ENCOUNTER - CONT'D

Anatomical Part	Injury Type	Number of Injuries	Injury Category	AIS Range
T-04	Avulsion	1	Fatal	00
T-04	Fracture	1	Major	2-3
T-04	Fracture	4	Major	2-3
T-04	Fracture Disloc	1	Fatal	2-3
T-04	Hematoma	1	Major	00
T-04	Transection	1	Fatal	5
T-04 Cord Inj	Fracture/Contus	1	Fatal	3
T-04 Cord Inj	Fracture/Contus	1	Major	3
T-05	Fracture	1	Fatal	2-3
T-05	Fracture	1	Fatal	2-3
T-05	Fracture	6	Major	2-3
T-06	Fracture	1	Fatal	2-3
T-06	Fracture	7	Major	2-3
T-06 Cord Inj	Fracture/Contus	1	Fatal	3
T-07	Fracture	1	Major	2-3
T-07	Fracture	3	Major	2-3
T-08	Fracture	2	Major	2-3
T-08	Sprain/Strain	1	Minimal	00/1
T-08	Transection	1	Fatal	5
T-08,9	Fracture	1	Fatal	2-3
T-09	Fracture	1	Fatal	2-3
T-09	Fracture	4	Major	2-3
T-09	Fracture Disloc	1	Fatal	2-3
T-10	Dislocation	1	Fatal	2-3
T-10	Fracture	1	Fatal	2-3
T-10	Fracture	1	Major	2-3
T-11	Dislocation	1	Fatal	2-3
T-12	Fracture	1	Fatal	2-3
T-12	Fracture	3	Major	2-3
T-12	Fracture Disloc	1	Fatal	2-3
T-12	Transection	1	Fatal	5
Thorax	Asphyxia	1	Fatal	00
Thorax	Crush Injury	1	Fatal	6
Thorax	Evisceration	1	Fatal	9
Thorax	Fracture	4	Fatal	1-5
Thorax	Multiple Inj	3	Fatal	9
Thorax	Rupture	1	Fatal	9
Thorax	Sprain/Strain	1	Minimal	00/00
Thorax	Transection	1	Fatal	9
Thumb	Amputation	1	Fatal	2
Tibia	Fracture	4	Fatal	2-3
Tibia	Fracture	1	Major	2-3
Tibia Fibula	Fracture	12	Fatal	2-3
Ulna	Fracture	1	Fatal	2-3
Wrist	Fracture	1	Fatal	2-3
Wrist	Fracture	1	Major	2-3

9. UNKNOWN

Anatomical Part	Injury Type	Number of Injuries	Injury Category	AIS Range
Abdomen	Hematoma	1	Fatal	3
Arm Lower	Fracture	1	Fatal	2-3
Arm Upper	Fracture	1	Fatal	2-3
Arm Upper	Fracture	1	Major	2-3
Back	Sprain/Strain	2	Minor	00/1
Body	Hemorrhage/Shock	1	Major	9/00
Body (Fatal)	Unknown	1	Fatal	9
Body Multiple	Unknown	3	Fatal	9
Brain	Amnesia	1	Minor	2-3
C-01	Dislocation	1	Fatal	2-3
Hand	Amputation	1	Fatal	3
Head	Fracture	1	Fatal	2-4
L-02	Fracture	1	Major	2-3
Leg Lower	Fracture	1	Fatal	2-3
Liver	Laceration	1	Fatal	2-5
Neck	Burn 2nd Degree	1	Minimal	1
Neck	Sprain/Strain	1	Minor	00/1
Neck	Sprain/Strain	1	Minimal	00/1

9. UNKNOWN - CONT'D

Anatomical Part	Injury Type	Number of Injuries	Injury Category	AIS Range
Never Recovered	Unknown	5	Fatal	9
Ribs	Fracture	1	Fatal	2-5
Ribs	Fracture	1	Major	2-5
Sacroiliac	Sprain/Strain	1	Minimal	00/00
Spinal Cord	Contusion	1	Fatal	3-6
T-06	Fracture	1	Fatal	2-3
Thumb	Avulsion	1	Minor	1-2
Unknown	Multiple Inj	1	Fatal	9
Unknown (Fatal)	Unknown	1	Fatal	9

TABLE B-4 - SERIOUS INJURY TABULATION (EXCLUDING 126 FATALITIES)

1. INTILIATION PHASE					3. EJECTION - CONT'D				
Anatomical Part	Injury Type	Number of Injuries	Injury Category	AIS Range	Anatomical Part	Injury Type	Number of Injuries	Injury Category	AIS Range
Face	Burn 2nd Degree	1	Major	1	T-07	Fracture	5	Major	2-3
Face	Burn 2nd Degree	1	Minor	1	T-07	Sprain/Strain	1	Minimal	00/1
Foot	Sprain/Strain	1	Minor	1/00	T-07,9,10	Fracture	1	Major	2-3
Neck	Burn 2nd Degree	1	Major	1	T-08	Fracture	7	Major	2-3
Neck	Burn 2nd Degree	1	Minor	1	T-09	Fracture	4	Major	2-3
2. PATH CLEARANCE - No serious injuries were reported					T-10	Fracture	5	Major	2-3
3. EJECTION					T-11	Fracture	10	Major	2-3
Anatomical Part	Injury Type	Number of Injuries	Injury Category	AIS Range	T-11,12	Fracture	1	Major	2-3
Arm Lower	Fracture	1	Major	2-3	T-12	Fracture	7	Major	2-3
Arm Lower	Sprain/Strain	1	Major	1/00	T-12	Fracture	1	Minimal	2-3
Back	Sprain/Strain	8	Minor	00/1	Thorax	Sprain/Strain	1	Minimal	00/00
Back	Sprain/Strain	13	Minimal	00/1	Ulna	Fracture	1	Major	2-3
Brain	Unknown	1	Minor	9	4. EMERGENCY				
C-01	Fracture	1	Minor	2-3	Anatomical Part	Injury Type	Number of Injuries	Injury Category	AIS Range
C-01	Sprain/Strain	1	Major	00/1	Arm Upper	Fracture	1	Major	2-3
C-01	Sprain/Strain	4	Minor	00/1	Arm Upper	Sprain/Strain	1	Minimal	1/00
C-01	Sprain/Strain	4	Minimal	00/1	Back	Sprain/Strain	2	Minimal	00/1
C-02	Sprain/Strain	1	Minor	00/1	Brain	Tear	1	Major	4-6
C-03	Fracture	1	Major	2-3	Brain	Toxic Reaction	1	Major	00
C-04,5,6	Fracture	1	Major	2-3	Femur	Fracture	1	Major	3
C-05	Fracture	1	Major	2-3	Head	Concussion	2	Major	2
Eye	Unknown	1	Major	9	Humerus	Fracture	4	Major	2-3
Finger	Avulsion	2	Minimal	1-2	Jaw	Fracture	1	Minor	1-2
Finger	Fracture	1	Major	1	Jaw	Fracture	1	Minimal	1-2
Foot	Contusion	1	Major	1	Knee	Dislocation	1	Major	2
Foot	Contusion	5	Minimal	1	Knee	Sprain/Strain	3	Major	2/00
Head	Concussion	1	Minor	2	Knee	Sprain/Strain	1	Minor	2/00
Head	Unknown	1	Major	9	L-01	Fracture	1	Major	2-3
Humerus	Fracture	1	Major	2-3	L-02	Fracture	1	Major	2-3
Jaw	Sprain/Strain	1	Major	N/A	Leg Upper	Fracture	1	Major	2-3
Knee	Sprain/Strain	1	Minor	2/00	Leg Upper	Sprain/Strain	1	Minimal	1/00
L-01	Fracture	11	Major	2-3	Neck	Sprain/Strain	1	Major	00/1
L-01	Sprain/Strain	1	Minor	00/1	Neck	Sprain/Strain	2	Minimal	00/1
L-01	Sprain/Strain	2	Minimal	00/1	Shoulder	Dislocation	6	Major	2
L-02	Fracture	2	Major	2-3	Shoulder	Fracture	2	Major	00
L-02	Fracture	1	Minimal	2-3	Shoulder	Sprain/Strain	3	Minimal	1/00
L-02	Sprain/Strain	1	Minimal	00/1	T-07	Fracture	1	Major	2-3
L-02,4	Fracture	1	Major	2-3	T-11	Fracture	1	Major	2-3
L-04	Sprain/Strain	1	Minimal	00/1	Thorax	Sprain/Strain	1	Minor	9
L-05	Sprain/Strain	1	Minimal	00/1	Tibia Fibula	Fracture	1	Major	2-3
Leg Lower	Fracture	1	Major	2-3	Ulna	Dislocation	1	Major	00
Leg Lower	Sprain/Strain	1	Minimal	1-2	Ulna	Fracture	3	Major	2-3
Neck	Fracture	1	Major	2-3	Ulna	Fracture Disloc	1	Major	2-3
Neck	Sprain/Strain	4	Major	00/1	Wrist	Fracture	1	Major	2-3
Neck	Sprain/Strain	1	Minor	00/1	5. MAN-SEAT SEPARATION				
Neck	Sprain/Strain	31	Minimal	00/1	Anatomical Part	Injury Type	Number of Injuries	Injury Category	AIS Range
Ribs	Fracture	1	Major	2-5	Brain	Contusion	1	Major	3-5
Sacroiliac	Sprain/Strain	1	Minimal	00/00	C-06,7	Fracture	1	Major	2-3
Scapula	Dislocation	1	Major	00	Head	Concussion	1	Major	2
Shoulder	Fracture/Disloc	1	Major	00/2	Humerus	Fracture	1	Major	2-3
Shoulder	Sprain/Strain	3	Minimal	1/00	Ribs	Fracture	1	Major	2-5
Sternum	Fracture	1	Major	2	Shoulder	Avulsion (?)	1	Major	00
T-01	Fracture	1	Major	2-3	Skull Basal	Fracture	1	Major	3-4
T-02	Stretching	1	Major	00	T-01	Fracture	1	Major	2-3
T-03	Fracture	1	Major	2-3	Tibia Fibula	Fracture	1	Major	2-3
T-03,4,5,6	Sprain/Strain	1	Minimal	00/1					
T-04	Fracture	2	Major	2-3					
T-04,5	Fracture	1	Major	2-3					
T-05	Fracture	4	Major	2-3					
T-05 Cord Inj	Fracture/Contus	1	Major	3					
T-06	Fracture	3	Major	2-3					
T-06	Sprain/Strain	2	Minimal	00/1					

6. PARACHUTE DEPLOYMENT

Anatomical Part	Injury Type	Number of Injuries	Injury Category	AIS Range
Arm Lower	Fracture	1	Major	2-3
Back	Sprain/Strain	1	Minor	00/1
Back	Sprain/Strain	2	Minimal	00/1
Hip	Sprain/Strain	1	Minor	1/00
Neck	Sprain/Strain	1	Major	00/1
Neck	Sprain/Strain	2	Minor	00/1
Neck	Sprain/Strain	1	Minimal	00/1
Scapula	Sprain/Strain	1	Minimal	00/00
Shoulder	Sprain/Strain	1	Major	1/00
Shoulder	Sprain/Strain	1	Minimal	1/00
Spinal Cord	Contusion	1	Major	3
T-12	Fracture	1	Major	2-3
Thorax	Sprain/Strain	1	Minor	00/00

7. DESCENT

Anatomical Part	Injury Type	Number of Injuries	Injury Category	AIS Range
Face	Burn 2nd Degree	1	Major	1
Hand	Burn 2nd Degree	1	Major	1
Neck	Burn 2nd Degree	1	Major	1
T-03	Fracture	1	Major	2-3

8. GROUND ENCOUNTER

Anatomical Part	Injury Type	Number of Injuries	Injury Category	AIS Range
Ankle	Fracture	4	Major	2-3
Ankle	Sprain/Strain	1	Major	1/00
Ankle	Sprain/Strain	3	Minor	1/00
Ankle	Sprain/Strain	6	Minimal	1/00
Arm Upper	Sprain/Strain	1	Minimal	1/00
Back	Sprain/Strain	6	Minor	00/1
Back	Sprain/Strain	5	Minimal	00/1
Body	Dehydration	1	Minor	00
Body	Heatstroke	1	Major	00
Body	Hemorrhage/Shock	1	Major	9/00
Body	Hypothermia	4	Major	1-5
Body	Hypothermia	3	Minor	1-5
Body	Hypothermia	1	Minimal	1-5
Body	Starvation	1	Minor	00
Brain	Amnesia	1	Minor	2-3
C-01	Sprain/Strain	2	Minimal	00/1
C-02	Fracture	1	Major	2-3
C-07	Sprain/Strain	1	Minimal	00/1
Face	Asphyxia	1	Major	00
Femur	Fracture	1	Major	3
Fibula	Fracture	2	Major	2
Finger	Avulsion	1	Minor	1-2
Finger	Fracture	1	Minor	1
Foot	Sprain/Strain	1	Minor	1/00
Head	Concussion	2	Major	2
Head	Concussion	1	Minor	2
Humerus	Fracture	1	Major	2-3
Kidney	Concussion	2	Major	2-3
Knee	Hemarthrosis	1	Major	00
Knee	Sprain/Strain	4	Major	2/00
Knee	Sprain/Strain	2	Minor	2/00
Knee	Sprain/Strain	4	Minimal	2/00
Knee	Tear	2	Major	2
L-01	Fracture	7	Major	2-3
L-01	Unknown	1	Major	9
L-02	Fracture	1	Major	2-3
L-02	Sprain/Strain	1	Minimal	00/1
L-03	Fracture	2	Major	2-3
L-05	Sprain/Strain	1	Minimal	00/1
Leg Lower	Fracture	1	Major	2-3
Leg Upper	Fracture	1	Major	3

8. GROUND ENCOUNTER - CONT'D

Anatomical Part	Injury Type	Number of Injuries	Injury Category	AIS Range
Lung	Contusion	1	Minor	3-4
Lung	Pneumothorax	1	Major	00-5
Neck	Sprain/Strain	1	Minor	00/1
Neck	Sprain/Strain	6	Minimal	00/1
Pelvis	Fracture	1	Major	2-3
Ribs	Dislocation	1	Major	00
Ribs	Dislocation	1	Major	00
Ribs	Fracture	1	Minor	2-5
Sacroiliac	Fracture	1	Major	3
Sacrum	Fracture	1	Major	2-3
Sacrum	Sprain/Strain	1	Minimal	00/00
Shoulder	Sprain/Strain	1	Minor	1/00
Shoulder	Sprain/Strain	1	Minimal	1/00
T-01	Fracture	1	Major	2-3
T-02	Fracture	1	Major	2-3
T-02	Fracture	1	Major	2-3
T-03	Fracture	1	Major	2-3
T-03	Fracture	3	Major	2-3
T-03	Hematoma	1	Major	00
T-04	Fracture	1	Major	2-3
T-04	Fracture	4	Major	2-3
T-04	Hematoma	1	Major	00
T-04 Cord Inj	Fracture/Contus	1	Major	3
T-05	Fracture	6	Major	2-3
T-06	Fracture	7	Major	2-3
T-07	Fracture	1	Major	2-3
T-07	Fracture	3	Major	2-3
T-08	Fracture	2	Major	2-3
T-08	Sprain/Strain	1	Minimal	00/1
T-09	Fracture	4	Major	2-3
T-10	Fracture	1	Major	2-3
T-12	Fracture	3	Major	2-3
Thorax	Sprain/Strain	1	Minimal	00/00
Tibia	Fracture	1	Major	2-3
Wrist	Fracture	1	Major	2-3

9. UNKNOWN

Anatomical Part	Injury Type	Number of Injuries	Injury Category	AIS Range
Arm Upper	Fracture	1	Major	2-3
Back	Sprain/Strain	2	Minor	00/1
Body	Hemorrhage/Shock	1	Major	9/00
Brain	Amnesia	1	Minor	2-3
L-02	Fracture	1	Major	2-3
Neck	Burn 2nd Degree	1	Minimal	1
Neck	Sprain/Strain	1	Minor	00/1
Neck	Sprain/Strain	1	Minimal	00/1
Ribs	Fracture	1	Major	2-5
Sacroiliac	Sprain/Strain	1	Minimal	00/00
Thumb	Avulsion	1	Minor	1-2

5. The existing data base has been evaluated for significant injury causation and the preliminary results are presented here. It contains much other data, including injury causing agent and action information and situational data such as ejection airspeed and altitude. Some of the preliminary findings will have importance to future design of escape systems, such as the information that 50% of all ejections took place at or below 1800 feet (above ground level) and nearly 28% occurred at 500 feet or below. 33.6% of pre-ACES II ejections occurred at 200 knots or less and 73.5% were at 300 knots or less. There were 8 open seat ejections from pre-ACES II ejection seat equipped aircraft at speeds between 500 to 650 knots. There were 3 fatalities and 5 survivors sustaining 1 minor and 4 major injury sets. There were 4 crewmembers ejected in two F-111 modules, one at 500 knots with two fatalities and the other at 652 knots with 2 survivors sustaining minimal and major injury sets. Sixty-five percent of ACES II ejections were at 200 knots airspeed or below and nearly 88% of these ejections were at 300 knots or less. Only 5 ACES II ejections took place at speeds of 500 knots or greater with two at 500-510 knots survived with minor injuries and three at 600-700 knots that resulted in fatalities.
6. **CONSIDERATIONS** - There appears to be a clear difference in the production of certain types of injuries caused by ground impact and windblast at levels that were unsurvivable. Head, neck and spine (not including compression fractures), upper leg and peivis fractures tended to be produced by severe impact or windblast exposure. Other injuries were associated with exposures to forces at more survivable levels, and while there was overlap (i.e., compression fractures of the thoracic spine caused during ejection of a crewmember later killed on ground impact), the data offers the opportunity to instrument ADAM for Injury Causation Anaiysis at two levels.
- Option A.** Full assessment of the entire range of possible injury causation forces, even at supra-lethal levels. This would include detection of pelvic fracture potentials, heart lacerations, brain injury and skull fracture potentials.
- Option B.** Assessment of injury causation forces at a level up to those most serious injuries that were survivable plus some means of assessing when those levels had been surpassed. An example proposition follows, based on the most common serious injuries or defined above, excluding the 126 fatalities.

Suggested Instrumentation for Measurement

- Head - acceleration profile.
- Cervical and Thoracolumbar Spine - compressive and shear (translational) forces - additionally should also record bending forces and limits of experienced kinematic response.
- Shoulder - impact and distractive forces
 - limits of experienced kinematic response and forces
- Upper Arm - bone shaft bending forces
- Lower Arm - bone shaft bending forces
- Elbow - kinematic response
- Thorax - acceleration profile
- Upper Leg - bone shaft bending forces
- Knee - kinematic response and bending forces
- Lower Leg - bone shaft bending forces
- Ankle - kinematic response, compressive and bending forces

Appendix C - Data Requirements and Sensors

APPENDIX C - DATA REQUIREMENTS AND SENSORS

Page 2

Channel Count	Bone Segment	Measures Parameters	Transducer Type(s)	Manufacturer(s) (Possible Sources)	Transducer Model(s)
41-43	Head	Linear triaxial accelerations.	Linear accelerometers.	Entran Devices Inc.	EGAXT-250 (x 3)
3 more channels	Head	Angular triaxial velocities, or	Magneto-hydro-dynamic -based angular velocity sensors or	Applied Technology Associates.	Model ARS-01 (Angular rate (velocity) sensor).
		Angular triaxial accelerations.	Magneto-hydro-dynamic -based angular acceleration sensors.		Model AAS-01 (Angular acceleration sensor).
29-34	Upper neck (C-1)	NOTE: This sensor is still under development. Two mutually perpendicular shear forces at the base of the skull, tensile/compressive (axial) forces through the neck and the three corresponding (orthogonal) moments. Loads applied between the neck and the base of the skull.	Strain-gage based upper neck load cell.	Robert A Denton Inc.	Model 1716 (six axis)
5-6 more channels	Lower neck (C-7)	Two shear forces at the base of the neck (C-7), and three orthogonal moments. Loads applied between the torso and the lower neck.	Strain-gage based lower neck load cell.	Robert A Denton Inc.	Model 1794 (six axis)
35-40	Lumbar Spine	Two shear forces at the lower end of ADAM's thoracolumbar spine (pelvic area), axial loads through the spine in the same region and three corresponding orthogonal moments.	Strain-gage based lumbar spine load cell.	Robert A Denton Inc.	Modified lower femur six-axis load cell model 1914
56-57 1 more channel	Lumbar Spine	Yaw, pitch and roll - Position	Single turn rotary/inim potentiometers.	Preh Electronic Industries, Spectrol. Ohmite Mfg. Co.	Model 76592-006. Model 142. Type AB or AS.
47-49	Chest	Linear triaxial accelerations.	Linear accelerometers.	Entran Devices Inc.	EGAXT-100 (x 3)
50-52	Pelvis	Linear triaxial accelerations.	Linear accelerometers.	Entran Devices Inc.	EGAXT-100 (x 3)
58-59	Shoulder (Sternoclavicular Joints).	Elevation/depression - Position (shrug)	Single turn rotary/inim potentiometers.	Preh Electronic Industries, Spectrol. Ohmite Mfg. Co.	Model 76592-006. Model 142. Type AB or AS.
60-61	Shoulder (Sternoclavicular Joints).	Protraction/retraction - Position	Single turn rotary/inim potentiometers.	Preh Electronic Industries, Spectrol. Ohmite Mfg. Co.	Model 76592-006. Model 142. Type AB or AS.
11,12	Shoulder joint (abducted) L/R	Flexion/extension - Position (joint rotation)	Single turn rotary/inim potentiometers.	Preh Electronic Industries, Spectrol. Ohmite Mfg. Co.	Model 76592-006. Model 142. Type AB or AS.

Appendix C - Data Requirements and Sensors

APPENDIX C - DATA REQUIREMENTS AND SENSORS					
Channel Count	Body Segment	Measured Parameters	Transducer Type(s)	Manufacturer(s) (Flexible Source)	Transducer Model(s)
15,16	Shoulder joint L/R	Flexion/extension - Position (joint rotation)	Single turn rotary/trim potentiometers.	Preh Electronic Industries. Spectrol. Ohmite Mfg. Co.	Model 76592-006. Model 142. Type AB or AS.
17,18	Shoulder joint L/R	External/internal rotation - Position (joint rotation)	Single turn rotary/trim potentiometers.	Preh Electronic Industries. Spectrol. Ohmite Mfg. Co.	Model 76592-006. Model 142. Type AB or AS.
8 more channels	Shoulder/Arm-joint L/R	Compressive and distractive forces. Two shear forces (reactions) at the upper humerus and the corresponding moments. (No torsion or axial measurements. Axial would be measured by the lower humerus load cell).	Strain gage-based load cell at the upper humerus.	Robert A. Denton Inc.	Modified upper tibia load cell model # 1000 or modified upper tibia load cell model 1583. Either system would be 4-axial.
19,20	Shoulder joint L/R	Abduction/Adduction - Position (joint rotation)	Single turn rotary/trim potentiometers.	Preh Electronic Industries. Spectrol. Ohmite Mfg. Co.	Model 76592-006. Model 142. Type AB or AS.
10 more channels	Humerus L/R	Bone shaft bending forces. Axial loads through the humerus, two shear, perpendicular loads at the lower end of the humerus and two perpendicular moments (reactions). No torsion measured.	Strain gage-based load cell at the lower humerus.	Robert A Denton Inc.	Modified lower femur load cell model 1914 or modified Hybrid III lower tibia sensor. Either system would be 5-axial.
21,22	Elbow L/R	Flexion/Extension - Position (joint rotation)	Single turn rotary/trim potentiometers.	Preh Electronic Industries. Spectrol. Ohmite Mfg. Co.	Model 76592-006. Model 142. Type AB or AS.
10 more channels	Radius (Forearm) L/R	Bone shaft bending forces. Axial loads through the radius, two shear, perpendicular loads at the upper end of the radius and two perpendicular moments (reactions). No torsion measured.	Strain gage-based load cell at the upper radius.	Robert A Denton Inc.	Modified femur or tibia load cell. Similar to upper humerus configuration but with 5-axial transducer.
23,24	Radius (Forearm) L/R	Supination/Pronation - Position (joint rotation)	Single turn rotary/trim potentiometers.	Preh Electronic Industries. Spectrol. Ohmite Mfg. Co.	Model 76592-006. Model 142. Type AB or AS.
62-63	Hand	Change of position.	Normally closed logic state sensor.		Logic state sensor.
1,2	Hip L/R	Abduction/Adduction - Position (joint rotation)	Single turn rotary/trim potentiometers.	Preh Electronic Industries. Spectrol. Ohmite Mfg. Co.	Model 76592-006. Model 142. Type AB or AS.
3,4	Hip L/R	Flexion/Extension - Position (joint rotation)	Single turn rotary/trim potentiometers.	Preh Electronic Industries. Spectrol. Ohmite Mfg. Co.	Model 76592-006. Model 142. Type AB or AS.

Appendix C - Data Requirements and Sensors

APPENDIX C - DATA REQUIREMENTS AND SENSORS

Page 4

CHANNEL COUNT	BODY SEGMENT	MEASURED PARAMETERS	TRANSDUCER TYPE(S)	MANUFACTURER(S) (Available Source)	TRANSDUCER MODEL(S)
5,6	Hip L/R	Medial/Lateral - Position (joint rotation)	Single turn rotary/trim potentiometers.	Preh Electronic Industries. Spectrol. Ohmite Mfg. Co.	Model 76592-006. Model 142. Type AB or AS.
20 more channels	Femur L/R	Bone shaft bending forces. Upper femur: two shear forces and three orthogonal moments (including torsion). Lower femur: two shear forces, two moments (no torsion) and axial loads through the femur.	Strain gage-based load cells at the upper and lower femur.	Robert A Denton Inc.	Modified upper femur load cell model 2193 and lower femur load cell model 1914. Both would be 5-axial.
7,8	Knee L/R	Flexion/Extension - Position (joint rotation)	Single turn rotary/trim potentiometers.	Preh Electronic Industries. Spectrol. Ohmite Mfg. Co.	Model 76592-006. Model 142. Type AB or AS.
9,10	Knee L/R	Medial/Lateral - Position (joint rotation)	Single turn rotary/trim potentiometers.	Preh Electronic Industries. Spectrol. Ohmite Mfg. Co.	Model 76592-006. Model 142. Type AB or AS.
25-28 16 to 18 more channels	Tibia (Lower leg) L/R	Bone shaft bending moments. Upper tibia: two shear forces and three orthogonal moments (including torsion). Lower tibia: two shear forces, two moments (no torsion) and axial loads through the femur. NOTES: Compressive (axial) loads through the tibia which may relate to ankle dislocation are measured by axial force channel of the lower tibia sensor. With the knee clevis axial sensor, additional loads passing through an axis along the knee and ankle joints can be measured (this axis is not the same as through the tibia bone shaft).	Strain gage-based load cells at the upper and lower tibia.	Robert A Denton Inc.	Upper tibia: Modified upper tibia load cell model # 1000 or modified upper tibia load cell model 1583 w/ or w/o modified knee clevis sensor model C-1587. Either system could be 5-axial (6 axes if using C-1587). Lower tibia: Modified lower femur load cell model 1914 or modified Hybrid III lower tibia load cell. Either system would be 5-axial.
2 more channels	Ankle L/R	Inversion/Eversion - Position	Single turn rotary/trim potentiometers.	Preh Electronic Industries. Spectrol. Ohmite Mfg. Co.	Model 76592-006. Model 142. Type AB or AS.
13,14		Parameters external to dummy			
44-46		Parameters external to dummy			
53-55		Parameters external to dummy			

APPENDIX D - DERIVATION OF SIX DEGREE-OF-FREEDOM EQUATIONS FOR THE HEAD

INTRODUCTION

A formulation of the dynamics of a six degree-of-freedom spring-damper system subjected to a time-varying acceleration profile is used to construct a lumped parameter translational and rotational strain function as a model for head injury. This system is comprised of a mass coupled via a series of spring-damper systems in each of the translational and rotational axes to a single "input" point. A sketch of the system considered is shown in Figure D-1. To excite the model, the input point is then subjected to a known set of input accelerations and the response of the mass provides the amount of strain introduced into the system. This strain is proposed as a basis for an injury criterion for the human head exposed to an arbitrary impact acceleration profile.

DERIVATION OF SYSTEM DYNAMICS

The equations of motion are developed herein using the Lagrangian method

$$\frac{\partial}{\partial t} \left(\frac{\partial T}{\partial \dot{q}} \right) - \frac{\partial T}{\partial q} + \frac{\partial V}{\partial q} - \frac{\partial F}{\partial \dot{q}} = 0 \quad [1]$$

where \bar{q} is the generalized coordinate vector with components

$$q = [x_1 \ y_1 \ z_1 \ \theta \ \phi \ \psi]^T ; \dot{q} = [\dot{x}_1 \ \dot{y}_1 \ \dot{z}_1 \ \dot{\theta} \ \dot{\phi} \ \dot{\psi}]^T \quad [2]$$

Each coordinate is defined in a following section.

KINETIC ENERGY EXPRESSION

The system kinetic energy (T) is expressed as:

$$T = \frac{1}{2} \int_m (\bar{v}_0 + \bar{\omega} \times \bar{\rho}) \cdot (\bar{v}_0 + \bar{\omega} \times \bar{\rho}) dm \quad [3]$$

where \bar{v} is the translational velocity vector and $\bar{\omega}$ (angular velocity) \times $\bar{\rho}$ (position vector of system mass center from a rotating reference frame) is the translational velocity relative to a rotating frame of reference. This simplifies to:

$$T = \frac{1}{2} M v_0^2 + \frac{1}{2} [I_x \omega_x^2 + I_y \omega_y^2 + I_z \omega_z^2 - 2I_{xy} \omega_x \omega_y - 2I_{xz} \omega_x \omega_z - 2I_{yz} \omega_y \omega_z] \quad [4]$$

where M is the body segment mass and I_{ij} are the moments of inertia about the ij axis.

POTENTIAL ENERGY EXPRESSION

The potential energy (V) expression for the system is

$$V = \frac{1}{2} \bar{K} \cdot (\bar{\rho} \cdot \bar{\rho}) + \frac{1}{2} \bar{G} \cdot (\angle \cdot \angle) + Mg(\beta_{31}x_1 + \beta_{32}y_1 + \beta_{33}z_1) \quad [5]$$

Where \angle is $[\Theta \ \psi \ \phi]$ and \bar{K} is the spring constant vector for the three translational axes, \bar{G} is the spring constant vector for the three rotational axes, $\bar{\rho}$ is defined as above, and β is a transformation defined later. This equation accounts for the energy storage capacity in each degree-of-freedom as well as the gravitational potential.

NON-CONSERVATIVE FORCES

The energy of the viscous damping losses (F) is accounted for by the following expression

$$F = \frac{1}{2} \bar{C}_T^T \{\dot{\rho} + \Omega_1 \times \bar{\rho}\} + \frac{1}{2} \bar{C}_R^T \{\alpha\}^{-1} \Omega \quad [6]$$

where \bar{C}_T and \bar{C}_R represent the translational axis viscous damping characteristics and the rotational axis viscous damping characteristics respectively, $\bar{\rho}$ is defined as above, and Ω_1 , Ω , and α are defined later.

SYSTEM KINEMATICS

To describe the motion of the system, let one Cartesian axis system be attached to the mass center (let this be X, Y, Z), another to the point P (X_1, Y_1, Z_1), and a system X_2, Y_2, Z_2 be regarded as inertial as shown in Figure D-2. Let Ω_1 represent the angular velocity of the X_1, Y_1, Z_1 frame relative to X_2, Y_2, Z_2 . Write components of Ω_1 along X_1, Y_1, Z_1 as $\Omega_{1x}, \Omega_{1y}, \Omega_{1z}$. Take Ω as the angular velocity of the X, Y, Z frame relative to X_1, Y_1, Z_1 with components $\Omega_x, \Omega_y, \Omega_z$ along the body-fixed X, Y, Z axes. The orientation of X_1, Y_1, Z_1 with respect to inertial space is determined by the Euler angles Θ_1, ψ_1, ϕ_1 as shown in Figure D-2, and that of the body relative to P by θ, ψ, ϕ . From this we can see that the angular velocities may be expressed using Euler angles as

$$\begin{aligned} \Omega_{1x} &= \dot{\phi}_1 - \psi_1 \sin \theta_1 \\ \Omega_{1y} &= \dot{\theta}_1 - \psi_1 \cos \theta_1 \sin \phi_1 \\ \Omega_{1z} &= \psi_1 \cos \theta_1 \cos \phi_1 - \dot{\theta}_1 \sin \phi_1 \end{aligned} \quad [7]$$

for P and likewise,

$$\begin{aligned}\Omega_x &= \dot{\phi} - \psi \sin \theta \\ \Omega_y &= \dot{\theta} - \psi \cos \theta \sin \phi \\ \Omega_z &= \psi \cos \theta \cos \phi - \dot{\theta} \sin \phi\end{aligned}\tag{8}$$

for the body. Given this, then the angular velocity $\bar{\omega}$ of the body relative to inertial space is given by

$$\bar{\omega} = \Omega + [\alpha] \Omega_1\tag{9}$$

where $[\alpha]$ is the transformation matrix between (X, Y, Z) and (X_1, Y_1, Z_1) described by

$$[\alpha] = \begin{bmatrix} \alpha_{11} & \alpha_{12} & \alpha_{13} \\ \alpha_{21} & \alpha_{22} & \alpha_{23} \\ \alpha_{31} & \alpha_{32} & \alpha_{33} \end{bmatrix}\tag{10}$$

and $\alpha_{11}, \alpha_{12}, \alpha_{13}, \dots$, etc. are given by the following expressions

$$\begin{aligned}\alpha_{12} &= \cos \theta \sin \psi \\ \alpha_{13} &= -\sin \theta \\ \alpha_{21} &= -\cos \phi \sin \psi + \sin \phi \sin \theta \cos \psi \\ \alpha_{22} &= \cos \phi \cos \psi + \sin \phi \sin \theta \sin \psi \\ \alpha_{23} &= \sin \phi \cos \theta \\ \alpha_{31} &= \sin \phi \sin \psi + \cos \phi \sin \theta \cos \psi \\ \alpha_{32} &= -\sin \phi \cos \psi + \cos \phi \sin \theta \sin \psi \\ \alpha_{33} &= \cos \phi \cos \theta\end{aligned}\tag{11}$$

Define the velocity of P with respect to inertial space (X_2, Y_2, Z_2) as \bar{u} . Thus, we have the linear velocity of P with respect to inertial space, along the instantaneous X_1, Y_1, Z_1 axes, expressed as

$$\bar{u} = [\beta] v_2\tag{12}$$

where $\beta_{11} = \alpha_{11}(\theta_1, \phi_1, \psi_1)$, $\beta_{12} = \alpha_{12}(\theta_1, \phi_1, \psi_1)$, $\beta_{13} = \alpha_{13}(\theta_1, \phi_1, \psi_1), \dots$, etc., and $\bar{v}_2 = [x_2 \ y_2 \ z_2]^T$. The inertial velocity of the body along the instantaneous X_1, Y_1, Z_1 axes is

$$\vec{v} = \vec{u} + \Omega_1 \times \vec{p} \quad [13]$$

Thus, v_0^2 as it appears in the kinetic energy equation is

$$v_0^2 = v_x^2 + v_y^2 + v_z^2 \quad [14]$$

Now inserting the velocities into the kinetic energy equation we have

$$T = T \left(\begin{array}{c} x_1, y_1, z_1; x_2, y_2, z_2; \theta_1, \phi_1, \psi_1; \theta, \phi, \psi \\ \text{time derivatives} \end{array} \right) \quad [15]$$

But, assuming that the motions of P are known, then $x_2, y_2, z_2, \theta_1, \psi_1$, and ϕ_1 are known functions of time. Hence T can be reduced to

$$T = T(x_1, y_1, z_1; \dot{x}_1, \dot{y}_1, \dot{z}_1; \theta, \psi, \phi, \dot{\theta}, \dot{\psi}, \dot{\phi}) \quad [16]$$

which contains only coordinates of the body of interest. The equations of motion now follow quickly from an application of Lagrange's equation by evaluating (1) using (3), (4), (5), (8), and (13).

EXAMPLE

An example set of the equations of motion for two axes, one translational (x-axis) and one rotational (pitch (θ) axis), is shown below. For this case the generalized coordinates are

$$q = [x_1 \ \theta]^T ; \dot{q} = [\dot{x}_1 \ \dot{\theta}]^T \quad [17]$$

This results in the following equation for the x-axis

$$\begin{aligned} &M(\ddot{x}_1 + \dot{u}_x + \dot{\Omega}_y z_1 + \Omega_y \dot{z}_1 - \dot{\Omega}_z y_1 - \Omega_z \dot{y}_1 - u_y \Omega_z + u_z \Omega_y \\ &- \dot{y}_1 \Omega_z + \dot{z}_1 \Omega_y + \Omega_z \Omega_x z_1 + \Omega_x \Omega_y y_1 - \Omega_z^2 x_1 - \Omega_y^2 x_1) \\ &+ K_x x_1 + Mg\beta_{31} + C_x(\dot{x}_1 + \Omega_y z_1 - \Omega_z y_1) = 0 \end{aligned} \quad [18]$$

and for the pitch axis

$$\begin{aligned}
 & [(I_y \cos\phi + I_z \sin\phi)^2 \ddot{\theta} + [(I_z - I_y) \sin\phi \cos\phi + (1 - 2\sin^2\phi) I_{yz}] \dot{\theta} \dot{\phi} \\
 & = [I_y (-\dot{\Omega}_1 \alpha_{21} - \Omega_1 \dot{\alpha}_{21} - \dot{\Omega}_1 \alpha_{22} - \Omega_1 \dot{\alpha}_{22} - \dot{\Omega}_1 \alpha_{23} - \Omega_1 \dot{\alpha}_{23}) \\
 & \quad + I_y (-\dot{\psi} \cos\theta \sin\phi + \psi \dot{\theta} \sin\theta \sin\phi - \dot{\psi} \phi \cos\theta \cos\phi) \\
 & \quad + I_{yz} (\dot{\psi} \cos\theta \cos\phi - \dot{\psi} \theta \sin\theta \cos\phi - \dot{\psi} \phi \cos\theta \sin\phi) \\
 & + I_{yz} (\dot{\Omega}_1 \alpha_{31} + \Omega_1 \dot{\alpha}_{31} + \dot{\Omega}_1 \alpha_{32} + \Omega_1 \dot{\alpha}_{32} + \dot{\Omega}_1 \alpha_{33} + \Omega_1 \dot{\alpha}_{33}) + I_{xy} \dot{\omega}_x] \cos\phi \\
 & \quad + [I_{xz} \dot{\omega}_x - I_z (\dot{\psi} \cos\theta \cos\phi - \dot{\psi} \theta \sin\theta \cos\phi - \dot{\psi} \phi \cos\theta \sin\phi) \\
 & \quad - I_z (\dot{\Omega}_1 \alpha_{31} + \Omega_1 \dot{\alpha}_{31} + \dot{\Omega}_1 \alpha_{32} + \Omega_1 \dot{\alpha}_{32} + \dot{\Omega}_1 \alpha_{33} + \Omega_1 \dot{\alpha}_{33}) \\
 & + I_{yz} (-\dot{\Omega}_1 \alpha_{21} - \Omega_1 \dot{\alpha}_{21} - \dot{\Omega}_1 \alpha_{22} - \Omega_1 \dot{\alpha}_{22} - \dot{\Omega}_1 \alpha_{23} - \Omega_1 \dot{\alpha}_{23}) \\
 & \quad - I_{yz} (\dot{\psi} \cos\theta \sin\phi - \dot{\psi} \theta \sin\theta \sin\phi + \dot{\psi} \phi \cos\theta \cos\phi)] (-\sin\phi) \\
 & \quad - (I_y \omega_y - I_{xy} \omega_x - I_{yz} \omega_z) (-\dot{\phi} \sin\phi) \\
 & \quad - (I_z \omega_z - I_{xz} \omega_x - I_{yz} \omega_y) (-\dot{\phi} \cos\phi) \\
 & \quad + (I_x \omega_x - I_{xy} \omega_y - I_{xz} \omega_z) (-\dot{\psi} \cos\theta - \Omega_1 \sin\theta \cos\psi \\
 & \quad \quad + \Omega_1 \sin\theta \sin\psi - \Omega_1 \cos\theta) \\
 & + (I_y \omega_y - I_{xy} \omega_x - I_{yz} \omega_z) (-\dot{\psi} \sin\theta \sin\phi + \Omega_1 \sin\phi \cos\theta \cos\psi + \Omega_1 \sin\phi \cos\theta \sin\psi \\
 & \quad \quad - \Omega_1 \sin\phi \sin\theta) \\
 & \quad + (I_z \omega_z - I_{xz} \omega_x - I_{yz} \omega_y) (-\dot{\psi} \sin\theta \cos\phi + \Omega_1 \cos\phi \cos\theta \cos\psi \\
 & \quad \quad + \Omega_1 \cos\phi \cos\theta \sin\psi - \Omega_1 \cos\phi \sin\theta) \\
 & \quad - K_\theta \theta - \left(\bar{C}_R^T [\alpha]^{-1} \Omega \begin{bmatrix} 0 \\ \cos\phi \\ \sin\psi \end{bmatrix} \right)
 \end{aligned} \tag{19}$$

These equations, along with the remaining four degrees-of-freedom, represent a set of simultaneous non-linear coupled differential equations that describe the motion of a body segment undergoing a known set of accelerations that are applied by a spring-damper system through each degree-of-freedom. This equation set can be systematically solved in its present form or linearized using small perturbation theory. The constant coefficients can be found in either of two ways:

- 1) Axial and torsional damping and spring coefficients for each axis to be found in the literature or by experiment; or
- 2) Reduction of problem to one of a Normal-mode vibrational problem involving system mode shapes and then a search for damping and natural frequency data in the literature.

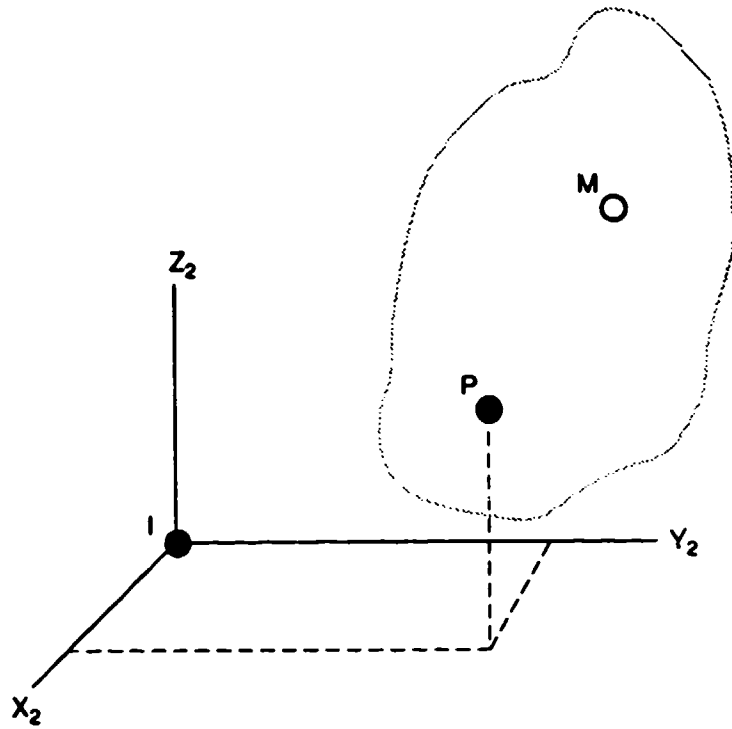

Figure D-1

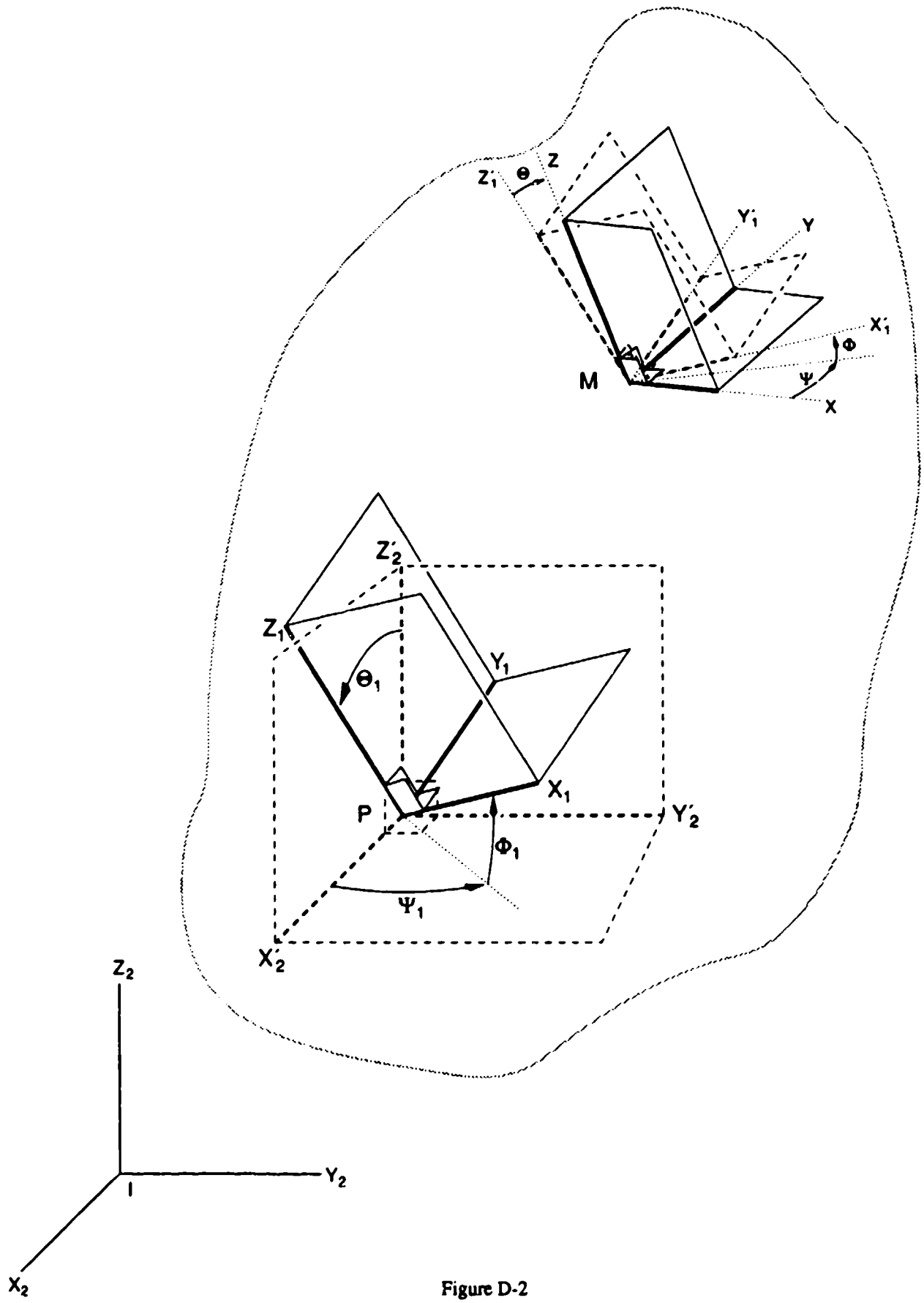

Figure D-2